

## HA46 E HA46 E PRO



### BOOST YOUR PRODUCTIVITY

- > Load capacity of 660 lb and 5° tilt
- > Oscillating axle with manual differential lock increases ground traction (PRO model only)
- > 4-wheel steering for more agility (PRO model only)

### OPERATE ANYTIME ANYWHERE WITH ZERO EMISSION

- > Full electric drive
- > Silent and clean operation
- > Versatile use: indoor / outdoor on all types of worksites

### EXTEND YOUR DUTY CYCLES

- > Multiple fast charging solutions adapted to all worksite situations
- > Removable Range Extender for flexible fast charging option (compatible with other PULSE0 machines)

### WORK SAFELY

- > Haulotte Activ'Shield Bar : anti-crushing system (standard in North America)
- > Haulotte Activ'Lighting System: load and unload the machine in low visibility conditions (standard PRO model)
- > Transport handle to ensure the operator is safe while loading and unloading (optional)



# HA46 E HA46 E PRO

## ARTICULATING BOOMS ELECTRIC

### TECHNICAL DATA

	HA46 E	HA46 E PRO
Working height	46.5 ft	
Platform height	45.9 ft	
Horizontal outreach	21.6 ft	
Up and over clearance	25.1 ft	
Lift capacity	660 lb	
<b>A</b> Length	22.3 ft	
Length - transport	19 ft	
<b>B</b> Width	7.7 ft	
<b>C</b> Height - stowed	9.1 ft	
Height - transport	9.1 ft	
<b>D</b> Wheelbase	6.11 ft	
<b>E</b> Ground clearance	12 in	
<b>F</b> x <b>G</b> Platform size	5.11 x 2.7 ft (option 7.10 x 2.11 m)	
<b>H</b> Length - transport	19 ft	
Height - transport	9.1 ft	
Tailswing	7 in	
Tilt alarm	0 °	
Drive speed	3.04 mph	
Maximum wind speed rating	28 mph	
Gradeability	40 %	
Turning radius - outside	0 ft	0 ft
Weight	16.052 lb	16.251 lb
Batteries	48V - 390Ah (C20)	

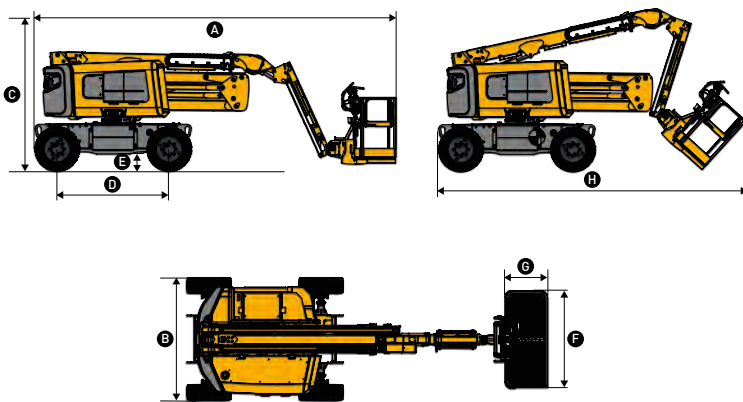

### STANDARD EQUIPMENT

- > Haulotte Activ'Lighting System (standard PRO model)
- > Proportional and simultaneous movements
- > Modular basket 8 ft x 3 ft
- > Access to the MyHaulotte multi-service portal
- > Universal telematic plug
- > 4-wheel drive and 2-wheel steering (standard E model)
- > 4-wheel drive and 4-wheel steering (standard PRO model)
- > Haulotte Activ'Screen
- > Haulotte Activ'Shield Bar (standard in North America)
- > Flashing light

### OPTIONS & ACCESSORIES

- > Non-marking tires
- > USB plug
- > Glazier kit
- > Sherpal telematics subscription
- > 360° continuous rotation (PRO model only)
- > Range Extender protective cover
- > Large basket 8 ft x 3 ft (Standard in North America)
- > Transport handle
- > REX 5.5 kW - Stage 5
- > Accelerated charger 380V

