



**ARTICULATING &
TELESCOPIC BOOMS
ALL-TERRAIN DIESEL**

**RTJ PRODUCT LINE
46 TO 85 FEET**

haulotte.com

Haulotte 
EQUIPMENT





CONTENTS

- APPLICATIONS..... 4**

- BENEFITS..... 7**
 -  **OPTIMAL SAFETY..... 8**

 -  **OUTSTANDING PRODUCTIVITY 12**

 -  **EXCELLENT ALL-TERRAIN CAPACITIES 17**

 -  **SUSTAINABLE DESIGN 21**

 -  **MAXIMIZED UPTIME 24**

- MODELS & OPTIONS..... 27**



With more than 30 years of experience designing booms, Haulotte is no stranger to the obstacles associated with operation and fleet management.

Our RTJ range of articulating and telescopic booms is designed to work in the most restrictive environments and tackle the most demanding projects.

RTJ booms incorporate our latest innovations to offer you the safest solutions on the market for working at heights, increase the productivity of your construction sites and optimize the uptime of your machines.

TAKE ADVANTAGE OF
HAULOTTE EXPERTISE

APPLICATIONS

OPT FOR **VERSATILITY**



CONSTRUCTION: BUILDING SHELL

Structural steel, siding, masonry, etc.



CONSTRUCTION: FINISHING

Electrical, HVAC, insulation, painting, etc.



MAINTENANCE AND UPKEEP

Plumbing, electrical, industrial cleaning, etc.



APPLICATIONS

OPT FOR **VERSATILITY**



SPECIFIC INDUSTRIAL OPERATIONS

Mining, airport applications, etc.



LANDSCAPING WORK

Pruning and green spaces.



EVENTS

Concert halls, stadiums, etc.

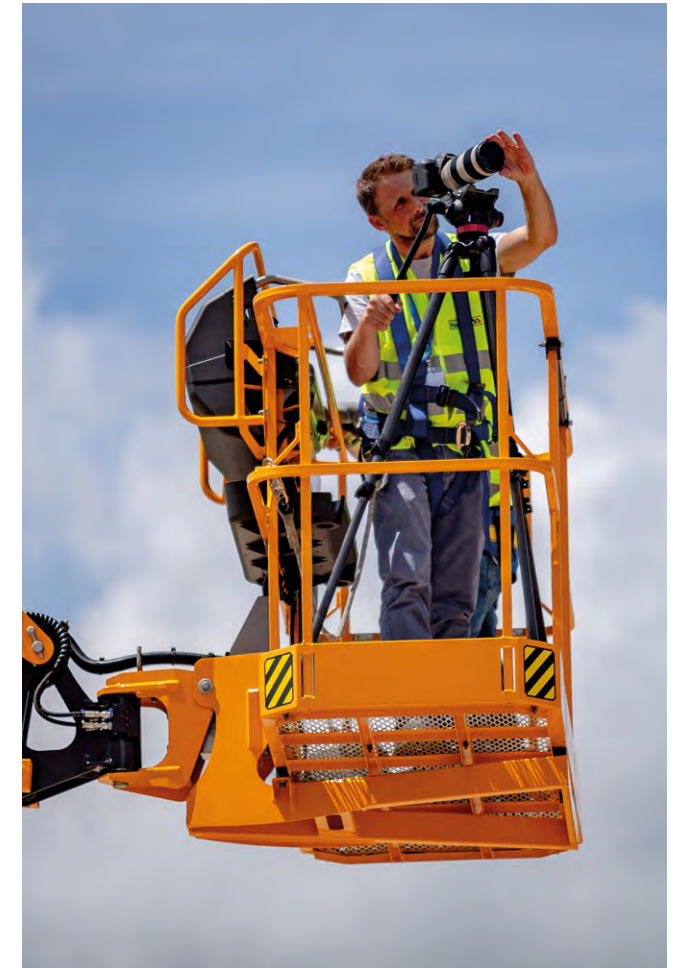



TELESCOPIC BOOMS

Telescopic architecture allows for straight and direct elevation.

Benefits:

- > **Extended horizontal outreach** for access to the most remote work areas.
- > **Ease of use** for greater efficiency.



ARTICULATED BOOMS

The articulating architecture features a boom arm with a pivot point.

Benefits:

- > **Ability to extend above obstacles** to reach the most inaccessible work areas.
- > **Work in highly confined areas** thanks to a more compact architecture.

CHOOSE THE RIGHT ARCHITECTURE

Designed to operate anywhere, even on the roughest terrain, Haulotte diesel articulating and telescopic booms offer a number of shared benefits. The most suitable architecture for you depends on the layout of your work area.

BENEFITS



OUTSTANDING PRODUCTIVITY

- > Haulotte Dual Load: load up to 1000 lb* in the basket
- > Haulotte Dual Reach: load up to 770 lb in the basket and enhance productivity on sloping ground (up to 6°)
- > Rapid, simultaneous movements
- > 360° continuous rotation
- > Better working envelope
- > Sherpal: telematics solutions for optimized machine use



OPTIMAL SAFETY

- > Haulotte Activ'Shield Bar 2.0 prevents crushing risks
- > Haulotte Activ'Lighting System ensures safety during nighttime loading and unloading operations
- > Proportional movements for greater precision and safety
- > Reflective stickers for greater visibility in the work area



GET THE BEST FROM THE RTJ RANGE



EXCELLENT ALL-TERRAIN CAPACITIES

- > 4-wheel steering / 4-wheel drive
- > Oscillating axle
- > Up to 45% slope climbing capacity



MAXIMIZED UPTIME

- > Haulotte Activ'Screen: on-board intuitive diagnostic interface
- > Haulotte Diag: wireless configuration and diagnostics
- > Easy access to components



SUSTAINABLE DESIGN

- > Haulotte Stop Emission System reduces engine and component use
- > Impact protection for exposed components

* Load capacity depending on models, more details on page 29.



OPTIMAL SAFETY



**OPTIMAL
SAFETY**

WORK IN COMPLETE **SAFETY**

Our teams go beyond mere compliance with regulatory standards, constantly innovating to offer the safest machines on the market.

PRECISE MOVEMENTS

Proportional controls ensure precise movements, guaranteeing smooth operation on the way up to the work area. No jolts, just fluid motion.



**AT HAULOTTE,
OPERATOR SAFETY IS OUR
NUMBER ONE PRIORITY**



**OPTIMAL
SAFETY**



WORK IN COMPLETE SAFETY

Haulotte 
ACTIV' SHIELD
B A R

EXCLUSIVE TECHNOLOGY

SECONDARY GUARDING DEVICE

Haulotte Activ'Shield Bar 2.0 is by far the safest and most effective system of its kind. Faced with a risk of entrapment, the operator is propelled against the bar. The machine automatically stops. Protected by the Safety Gap, the operator maintains easy access to controls with unobstructed visibility.



BUFFER ZONE

to prevent inadvertent activation.



STOP POSITION

to immediately stop the machine. Only safe movements intended to move away from the obstacle remain possible.



SAFETY GAP

with wide clearance of the bar to prevent driver entrapment and enable the driver to adopt a safe position inside the basket if necessary.



**OPTIMAL
SAFETY**



Illuminated controls
on the upper and
lower control box



Automatic activation
with the twilight sensor

Illuminated area
around the machine



SAFE OPERATIONS IN LOW VISIBILITY CONDITIONS

Haulotte 
ACTIV' LIGHTING
SYSTEM

EXCLUSIVE TECHNOLOGY

ULTRA-HIGH-PERFORMANCE LIGHTING SYSTEM

Booms are generally loaded and unloaded early in the morning or in the evening. To ensure safe performance of these delicate procedures, RTJ models feature the innovative high-performance Haulotte Activ' Lighting System. Comprising 10 LED spotlights, it provides ideal illumination of the basket, controls and the maneuvering area around the machine. For greater visibility on site, HA20 RTJ / HA61 RTJ PRO models feature 2 reflective stickers on the counterweight.



Reflective
stickers

OUTSTANDING PRODUCTIVITY



**OUTSTANDING
PRODUCTIVITY**

**QUICK AND
EASY ACCESS
TO THE
WORK AREA**



BETTER WORKING ENVELOPE

Featuring the best working envelope on the market, RTJ booms let you reach the most inaccessible areas. On articulating booms, the height of the up and over clearance makes it possible to clear even the highest obstacles.

SIMULTANEOUS MOVEMENTS AND 360° ROTATION

Ultra-fast elevation speed combined with simultaneous movement controls and 360° turret rotation let you reach the work area quickly for greater efficiency.



OUTSTANDING PRODUCTIVITY



BOOST YOUR PRODUCTIVITY

On the construction site, many situations require the loading of a large weight in the platform. Difficult terrain means having to move on slopes. To overcome these problems and boost your productivity, Haulotte has created two innovations for the various models in the RTJ range.

TANGIBLE BENEFITS ON THE JOB SITE:

- > Save time by limiting the number of round trips between the ground and the work area
- > Work safely by avoiding unsafe practices
- > Increase load capacity for better productivity
- > Access and work on floors with more slopes



**OUTSTANDING
PRODUCTIVITY**

INCREASE LOAD CAPACITY

Haulotte **DUAL** LOAD

Haulotte Dual Load allows you to increase the load in the basket up to 772 lb or 1000 lb*. The working envelope is reduced in this case to guarantee the stability of the machine.

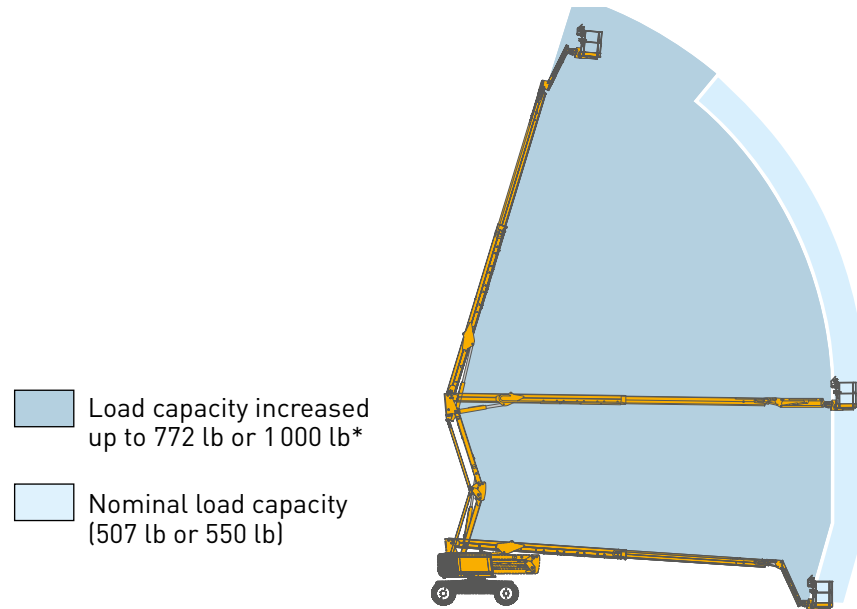

Haulotte **DUAL** REACH

Haulotte Dual Reach allows you to increase the load in the basket from 550 lb to 772 lb while working on sloping ground. The machine continues to rise and work on a maximum 6° slope (longitudinal or lateral).

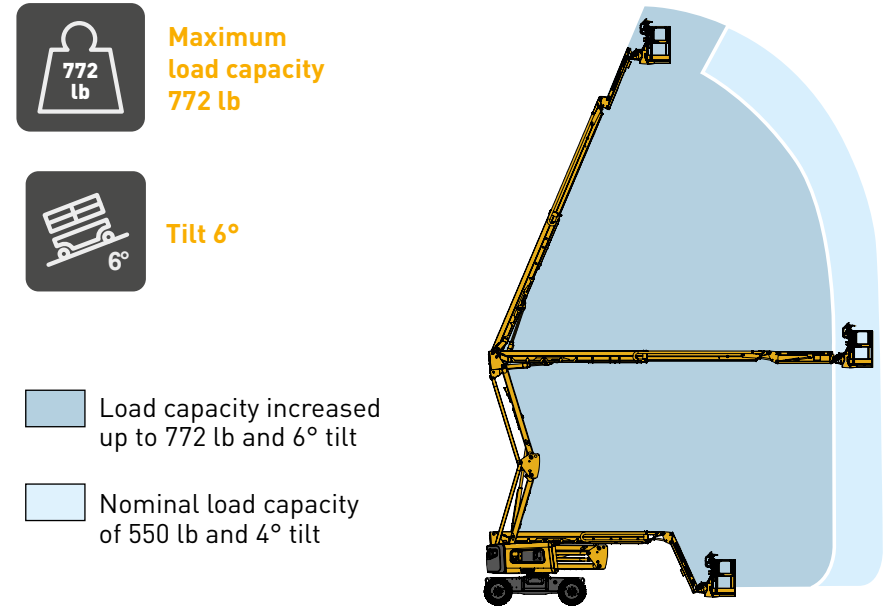

* Load capacity depending on models, more details on page 29.



EXCELLENT
ALL-TERRAIN
CAPACITIES



**OUTSTANDING
ALL-TERRAIN CAPACITY**

ENJOY **EXCEPTIONAL** DRIVABILITY

RTJ models always feature 4-wheel drive to operate anywhere, even on the roughest terrain.

EXCELLENT TERRAIN FOLLOWING

- > **The oscillating axle** adjusts the position of the axle to adapt to the terrain and keep the wheels in contact with the ground,
- > **The solid cured-on tires*** are extremely sturdy, hugging the ground and absorbing shocks. They are also available in markless version for use on sensitive floors or those whose appearance require special care,
- > **The limited-slip differential** adjusts the speed of each wheel, preventing the loss of traction...

...ON LOW TRACTION SURFACES...

- > **The differential lock** offers additional traction on loose or slippery surfaces. By locking the differential, power is transmitted to each wheel to power the machine through challenging terrain.

Solid cured-on tires

Oscillating axle

* The HT67 model is equipped with foam-filled tires



**OUTSTANDING
ALL-TERRAIN CAPACITY**



**DIFFERENT
STEERING
MODES TO SUIT
ANY SITUATION**

Enjoy greater agility thanks to 4-wheel steering:

> **In 4-wheel steering mode**, the turning radius is shortened, enabling you to maneuver in tight or congested spaces.

**SUPERIOR
DRIVABILITY**



> **Crab steering** lets you move in any direction, making it easier to access the work area.



Haulotte

SUSTAINABLE DESIGN



**SUSTAINABLE
DESIGN**



OPTIMIZE YOUR TOTAL COST OF OWNERSHIP

When operators are working at heights, booms may remain immobile for several hours.

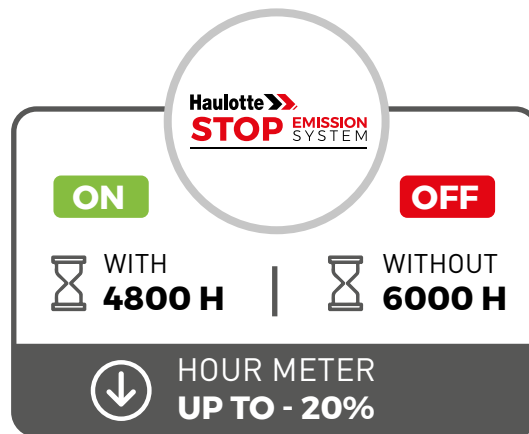

Haulotte **STOP** EMISSION SYSTEM

EXCLUSIVE TECHNOLOGY

START & STOP SYSTEM

The RTJ range is equipped with the Haulotte Stop Emission System, which automatically stops the engine after a period of idle running. The engine instantly restarts when the operator performs an action.

OPTIMIZED TOTAL COST OF OWNERSHIP

- > Use of the engine and peripheral components reduced by up to 20%,
- > Lower fuel consumption,
- > Longer intervals between maintenance,
- > Greater residual value.

RESPECTFUL OF THE ENVIRONMENT AND PEOPLE NEARBY

- > Reduced air and noise pollution,
- > Greater comfort for people living or working in the area.



SUSTAINABLE DESIGN

SIMPLIFY MAINTENANCE OPERATIONS

Components requiring regular maintenance are easily accessible, thus making maintenance operations simple and less time-consuming.



Swing out engine tray for access to the battery and oil filter

Coolant tank

Air filter

Fuel filter

Battery

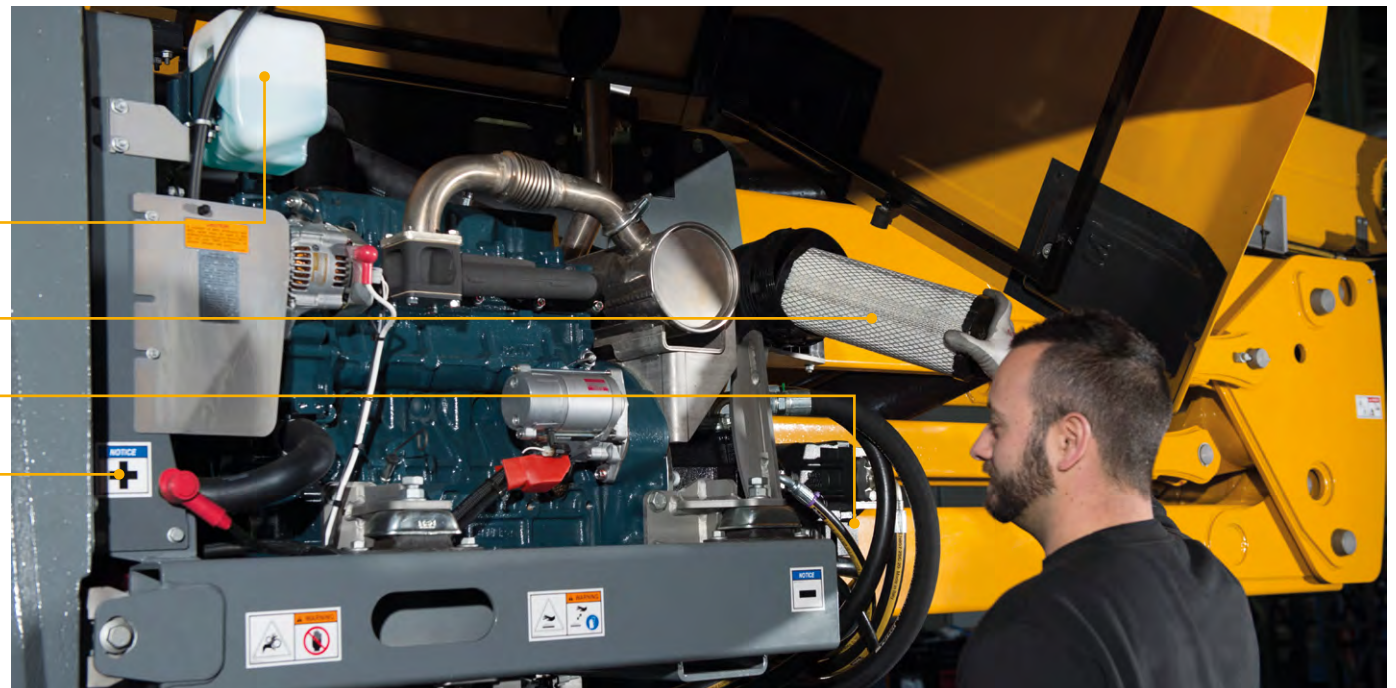

MAXIMIZED UPTIME

24 MAXIMIZED UPTIME

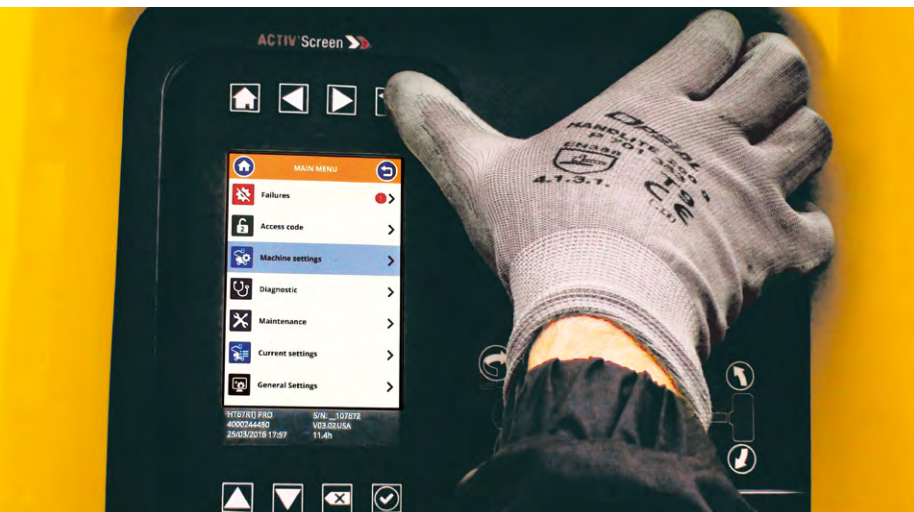

MAXIMIZE THE UPTIME OF YOUR FLEET

Haulotte **ACTIV' SCREEN**

EXCLUSIVE TECHNOLOGY

ON-BOARD CONFIGURATION AND DIAGNOSTIC TOOL

Haulotte Activ'Screen makes life easier for users and technicians on a daily basis, providing access to:

- > Machine configuration,
- > Information on machine functioning (tilt sensing, overloading, fuel level),
- > Preventative maintenance operations,
- > Diagnosis of malfunctions and instructions for resolution.



ALL FUNCTIONS AVAILABLE ON THE GO



All Haulotte Activ'Screen functions are available on the mobile app: Haulotte Diag. Technicians enjoy wireless mobility for conducting more effective configuration and diagnostics.

WORK IN THE MOST RESTRICTIVE ENVIRONMENTS



ULTRA-DURABLE PROTECTIVE HOUSING AND TOOL TRAY made of composite material



REINFORCED TURRET HOODS with metal support framework



ANTICORROSION TREATMENT on axles, fasteners and painted components. Built to withstand 500h salt spray test



LOAD SENSING SYSTEM PROTECTED within the platform yoke assembly

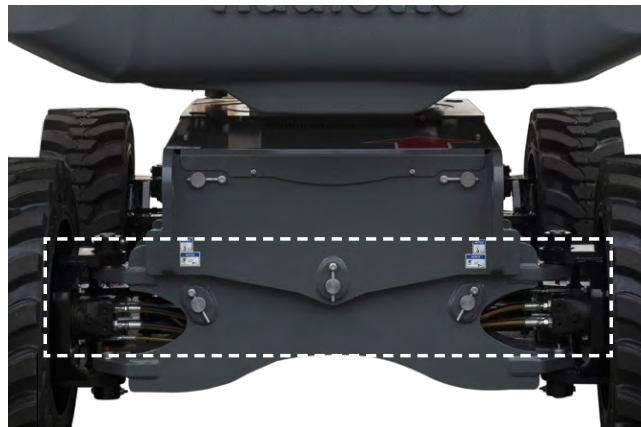

STEERING CYLINDERS PROTECTED inside the frame



BOOM PROTECTED by the counterweight frame

MODELS & OPTIONS

MODELS & OPTIONS

DESIGNED
TO MEET
**YOUR EVERY
NEED**

**EVERY CONSTRUCTION
SITE IS UNIQUE.
THAT'S WHY HAULOTTE
OFFERS A WIDE RANGE
OF MODELS AND
EQUIPMENT**

Haulotte

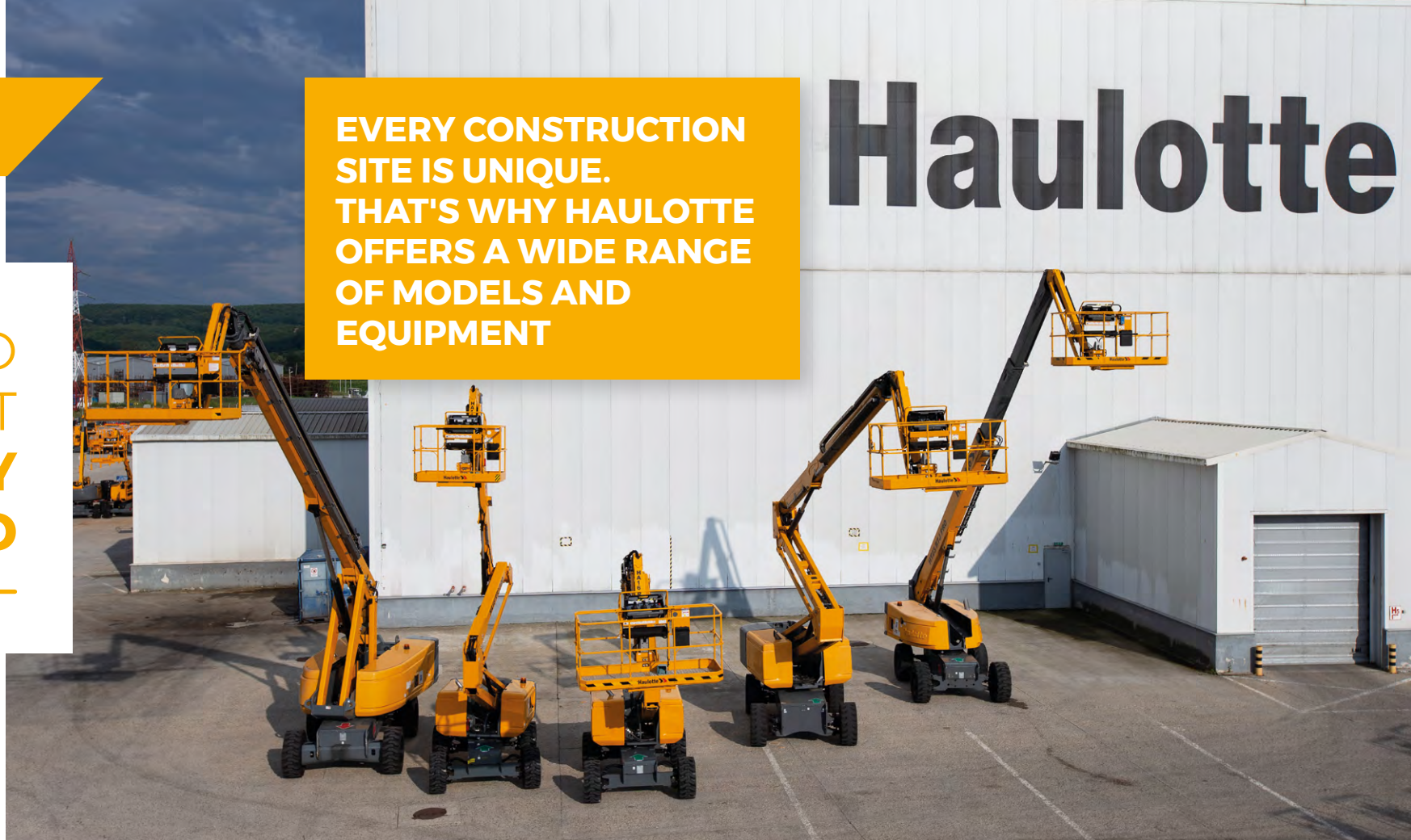

7 MODELS

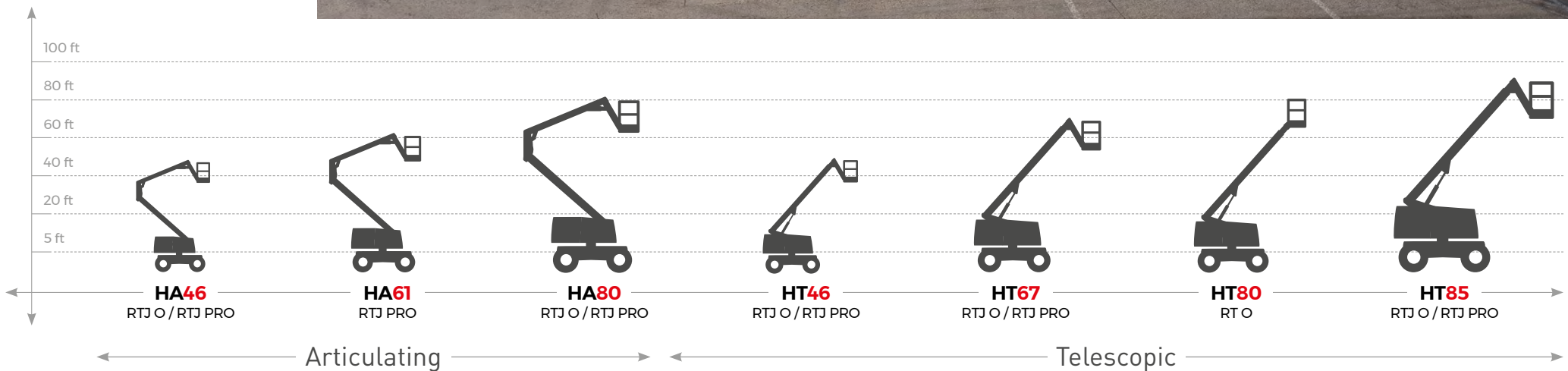

Availability of models may vary by region. Please contact your Haulotte representative.

MODELS & OPTIONS

CHOOSE THE VERSION BEST SUITED TO YOUR NEEDS

		HA46		HA61	HA80		HT46		HT67		HT80	HT85	
		RTJ O	RTJ PRO	RTJ PRO	RTJ O	RTJ PRO	RTJ O	RTJ PRO	RTJ O	RTJ PRO	RT O	RTJ O	RTJ PRO
CAPACITY	Platform height	45 ft 11 in		61 ft	80 ft 1 in		46 ft 3 in		67 ft		80 ft 1 in	85 ft	
	Up and over clearance	25 ft 1 in		27 ft 11 in	30 ft 6 in		-		-		-	-	
	Maximum outreach	27 ft 3 in		39 ft 1 in	57 ft 5 in		42 ft 8 in		60 ft 5 in		72 ft 1 in	78 ft 3 in	
	Basket load capacity	500 lb 2 persons		550 lb 2 persons	550 lb 2 persons		550 lb 2 pers.		500 lb 2 persons		500 lb 2 persons	500 lb 2 persons	
	Dual Load	-		-	■ 770 lb 2 pers.		■ 770 lb 2 pers.		■ 990 lb 3 pers.		■ 770 lb 2 pers.	■ 770 lb 2 pers.	
	Dual Reach	-		○ 770 lb / 6° 2 pers	-		-		-		-	-	
	Maximum wind speed	28 mph		28 mph	28 or 37 mph		28 mph		28 or 37 mph		28 or 37 mph	28 or 37 mph	
EQUIPMENTS	Wheel-steer	2	4	4	2	4	2	4	2	4	2	2	4
	Tires	Solid		Solid	Solid		Solid		Foam-filled		Solid	Solid	
	Oscillating axle	●	●	●	●	●	●	●	●	●	●	●	●
	Turret rotation	○ 355°	● 360° cont.	● 360° cont.	● 360° cont.	● 360° cont.	● 360° cont.	● 360° cont.	● 360° cont.	● 360° cont.	● 360° cont.	● 360° cont.	● 360° cont.
	Jib	●	●	●	●	●	●	●	●	●	-	●	●
INNOVATIONS	Activ'Shield Bar 2.0	■	●	●	■	●	■	●	■	●	■	■	●
	Activ'Lighting System	○	●	●	○	●	○	●	○	●	○	○	●
	Activ'Screen	●	●	●	●	●	●	●	●	●	●	●	●
	Stop Emission System	●	●	●	●	●	●	●	●	●	●	●	●

● Standard / ■ Mandatory option / ○ Option / - Not available

MODELS & OPTIONS

CHOOSE THE
EQUIPMENT
SUITED
TO YOUR
BUSINESS



CUSTOMIZE THE MODEL TO SUIT YOUR ENVIRONMENT

- > Cold & Arctic weather package
- > Warm weather package
- > Anti-overspeed kit
- > Non-marking tires



INCREASE YOUR PRODUCTIVITY

- > Haulotte Dual Reach
- > Haulotte Dual Load
- > Glazier pack
- > Pipe cradle
- > Compressed air line
- > 3.5, 6.5 or 12 kW hydraulic generator
- > AC power to platform



ENHANCE YOUR SAFETY AND COMFORT

- > Haulotte Activ'Lighting System
- > Haulotte Activ'Shield Bar
- > Strong wind package
- > Lateral swing door
- > Circuit breaker or ground fault interrupter

Availability of optional equipment varies by model.
Please contact your Haulotte representative.

NOTES



A series of horizontal dotted lines for taking notes, spanning the right half of the page.



HAULOTTE GROUP, 3409 Chandler Creek Road - Virginia Beach - VA - 23453
Tel: 757.689.2146 · Toll Free: 800.537.0540
www.haulotte-usa.com

Haulotte 
LET'S DARE TOGETHER