



US009022006B2

(12) **United States Patent**
Segawa

(10) **Patent No.:** **US 9,022,006 B2**
(45) **Date of Patent:** **May 5, 2015**

(54) **METHOD AND DEVICES FOR PROCESS INTENSIFIED WALL INTEGRATED OPERATIONS FOR IC ENGINES**

6I/14 (2013.01); *F02M 61/20* (2013.01); *F02M 51/061* (2013.01); *F02M 61/1813* (2013.01)

(58) **Field of Classification Search**
CPC . *F02M 43/04*; *F02M 51/061*; *F02M 61/1813*; *F02M 61/14*
USPC 123/298, 299, 300, 525, 470, 536, 538
See application file for complete search history.

(71) Applicant: **Enock N Segawa**, Grand Rapids, MI (US)

(72) Inventor: **Enock N Segawa**, Grand Rapids, MI (US)

(*) Notice: Subject to any disclaimer, the term of this patent is extended or adjusted under 35 U.S.C. 154(b) by 223 days.

(56) **References Cited**

U.S. PATENT DOCUMENTS

2,577,518 A * 12/1951 Guerasimoff 123/27 R
5,263,316 A * 11/1993 Shekleton 60/804
5,966,926 A * 10/1999 Shekleton et al. 60/39,094

* cited by examiner

(21) Appl. No.: **13/668,287**

(22) Filed: **Nov. 4, 2012**

Primary Examiner — Hai Huynh

(65) **Prior Publication Data**

US 2013/0312699 A1 Nov. 28, 2013

(57) **ABSTRACT**

Related U.S. Application Data

(60) Provisional application No. 61/555,833, filed on Nov. 4, 2011.

Many IC engine inefficiencies are linked to the relatively low mixture formation rates of current injection methods. Process intensification (PI) is excellent at high mixture formation rates, high mass transfer rates, and short residence times, therefore a wall integrated injection method and device featuring PI has been provided. It allows increased number of injection sites and interfacial surface area between fluid jets and the volume of the squash area, hence high mixture formation rates shorter Liquid Lengths and the use of micro nozzles to further intensify the mixing process by locally mixing fuel and oxidant. This allows high EGR and low compression ratios and better control of HCCI start of ignition. PI effectively achieves thermo and species stratification for extending the load range of the HCCI engine while permitting effective water addition for reciprocating and turbine for lower exhaust heat and less fuel burned hence less CO2 emissions.

(51) **Int. Cl.**

F02M 61/14 (2006.01)
F02M 29/00 (2006.01)
F02B 17/00 (2006.01)
F02M 43/04 (2006.01)
F02B 1/14 (2006.01)
F02M 61/18 (2006.01)
F02M 61/20 (2006.01)
F02M 51/06 (2006.01)

(52) **U.S. Cl.**

CPC *F02M 29/00* (2013.01); *F02B 17/00* (2013.01); *Y02T 10/128* (2013.01); *F02M 43/04* (2013.01); *F02B 1/14* (2013.01); *F02M*

15 Claims, 20 Drawing Sheets

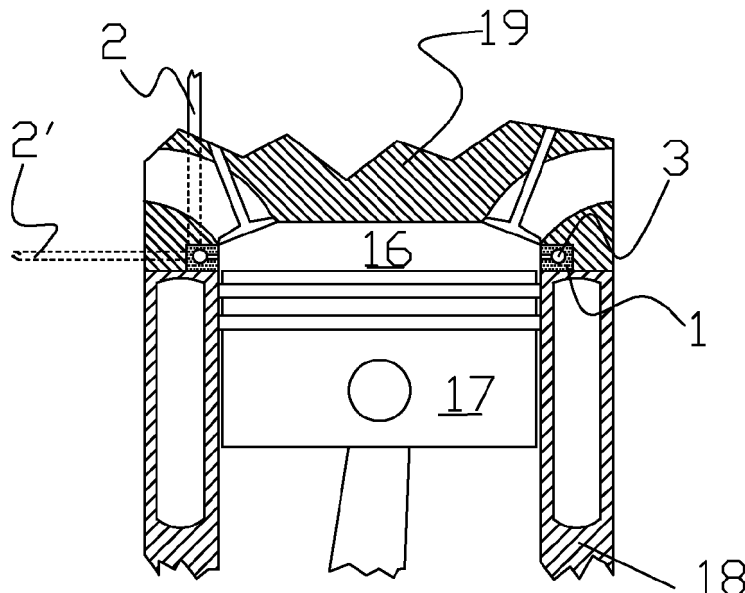

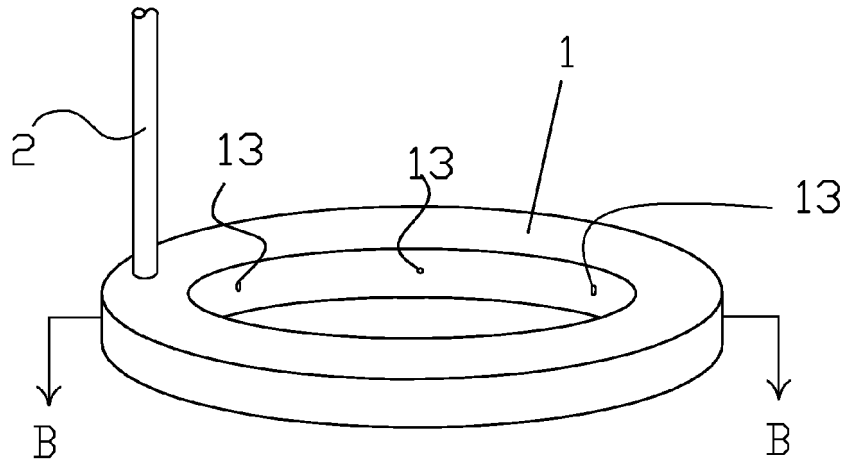

FIG.1

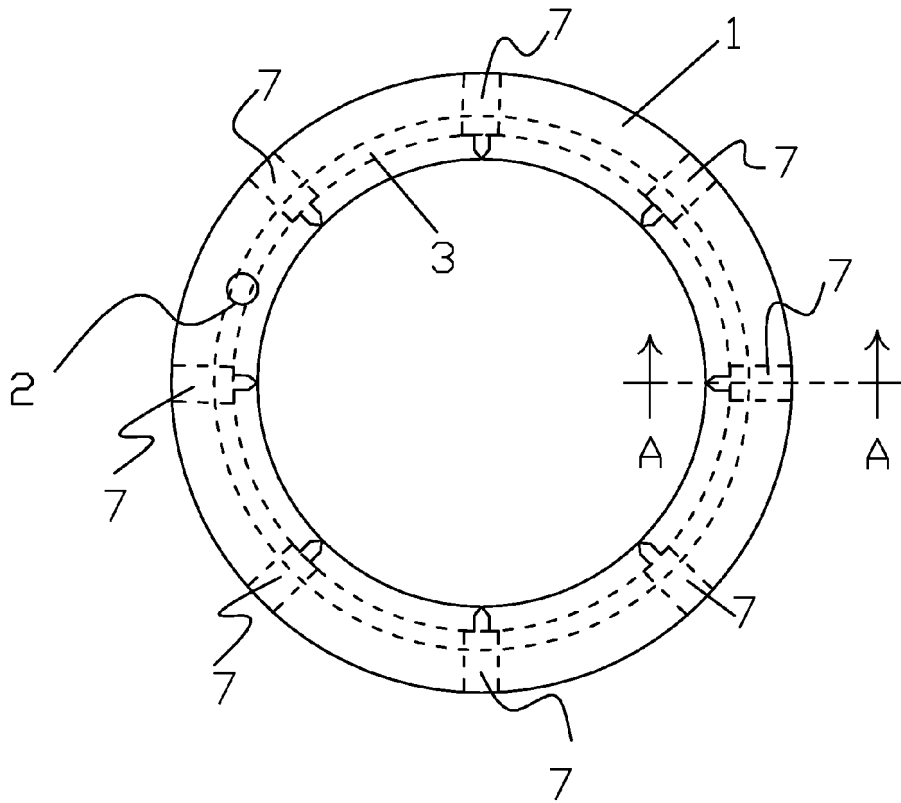

FIG.2

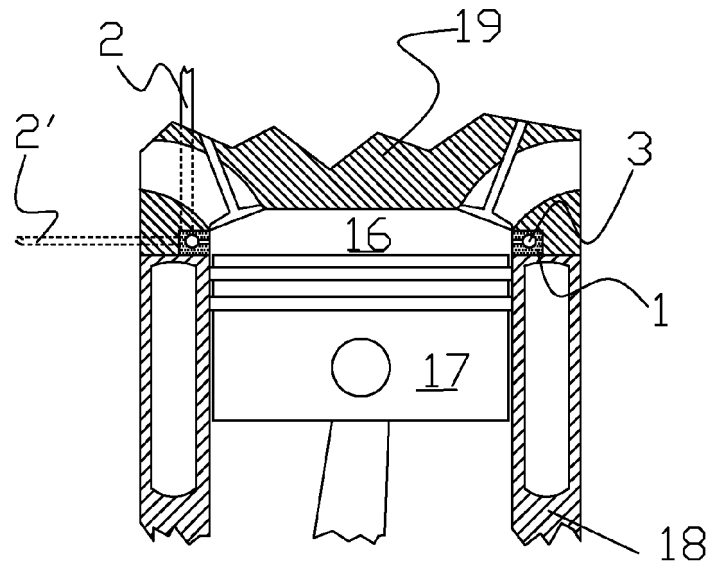

FIG.3

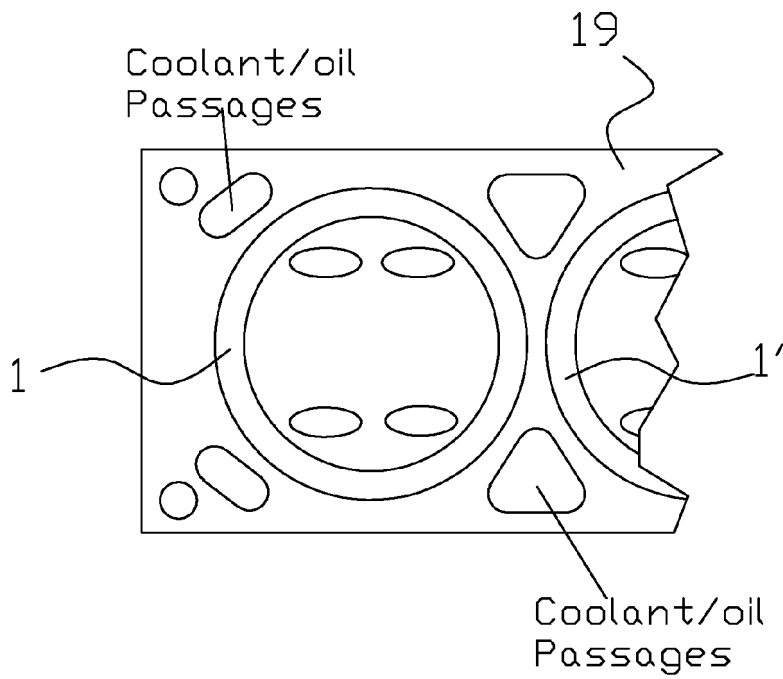

FIG.4

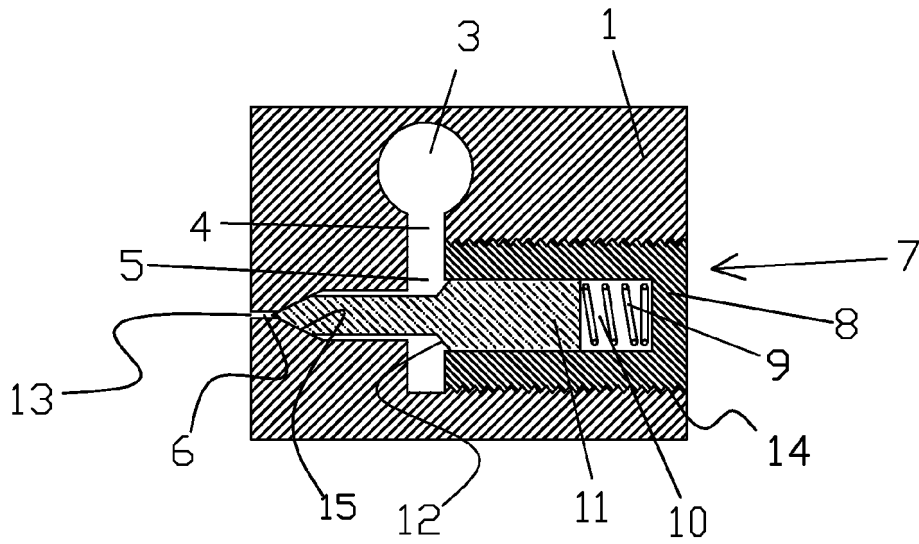

FIG. 5

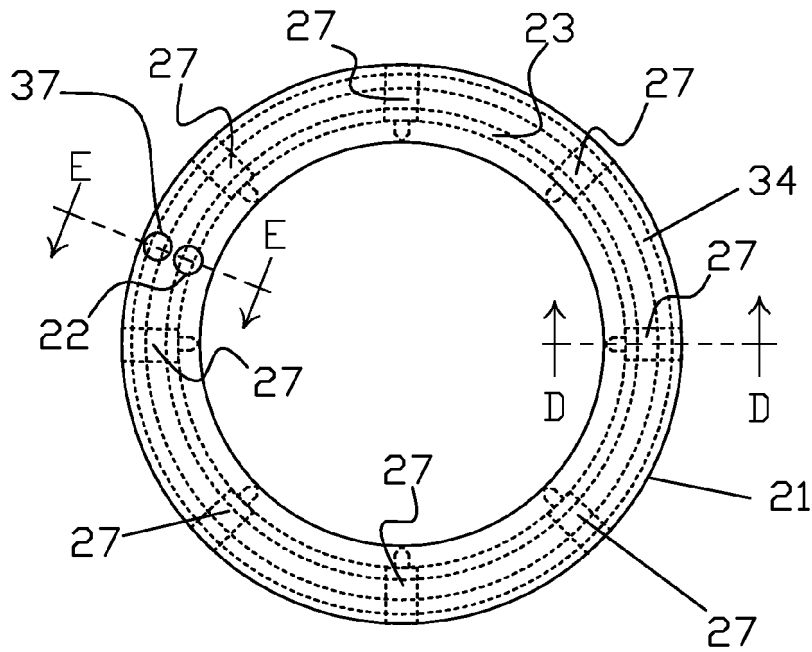
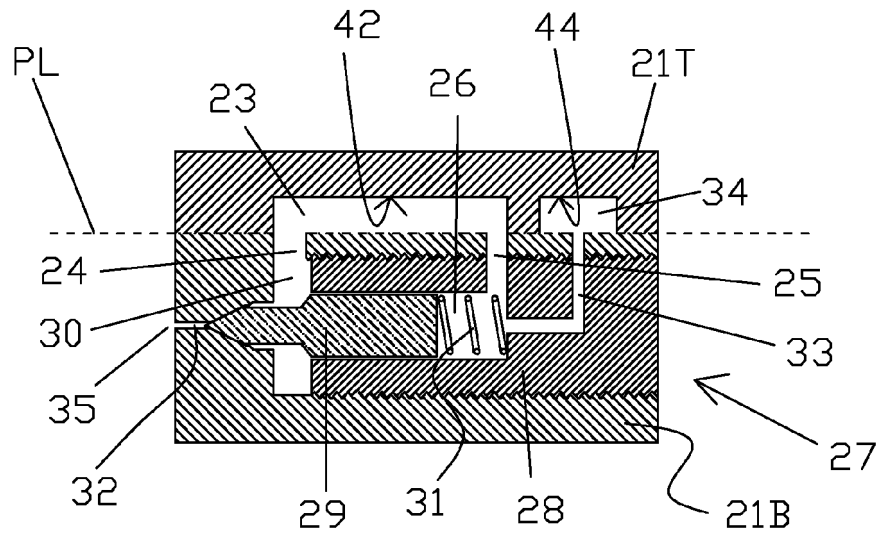
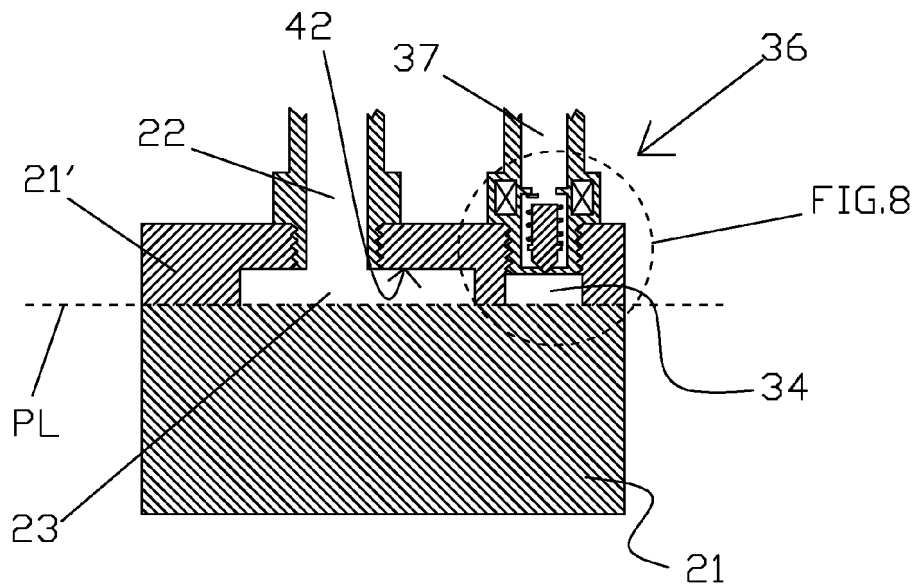

FIG. 6



A



B

FIG.7

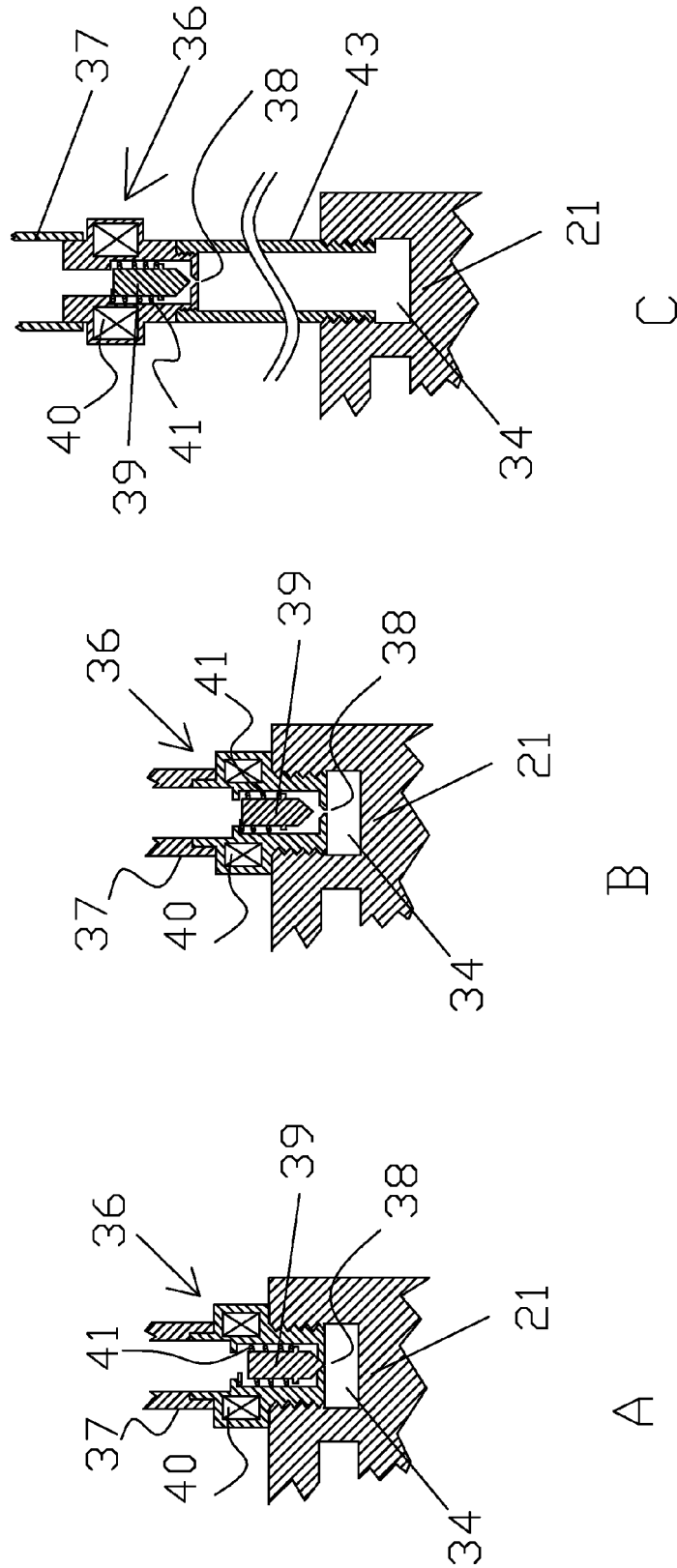
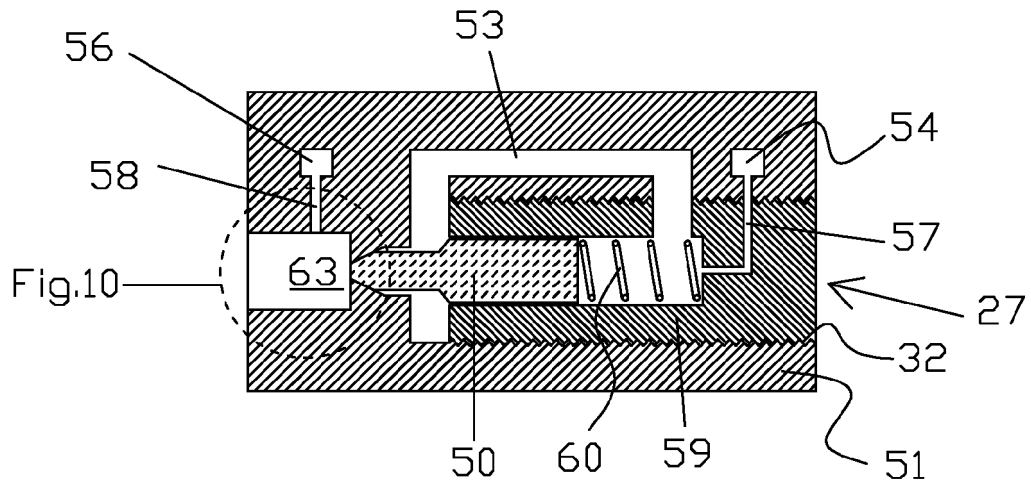
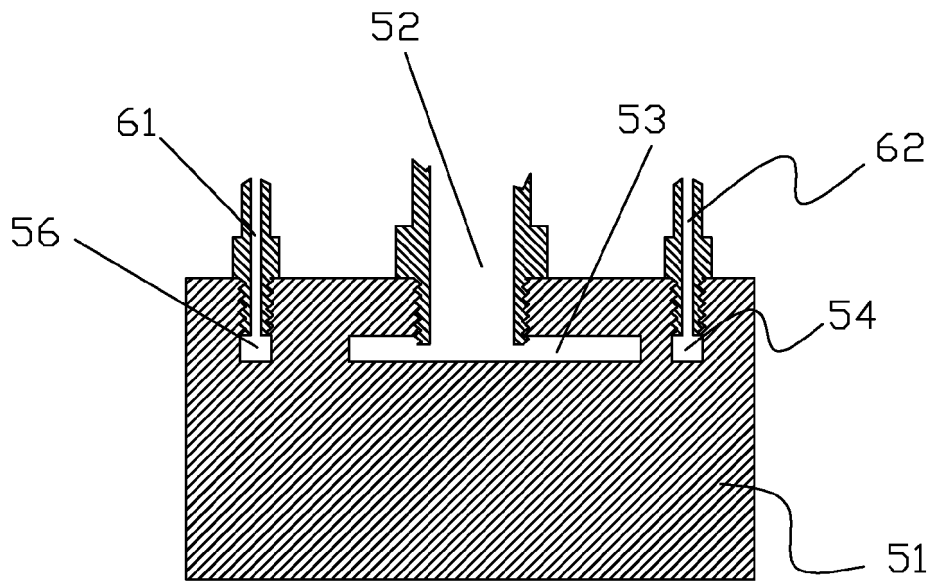

FIG.8



A



B

FIG. 9

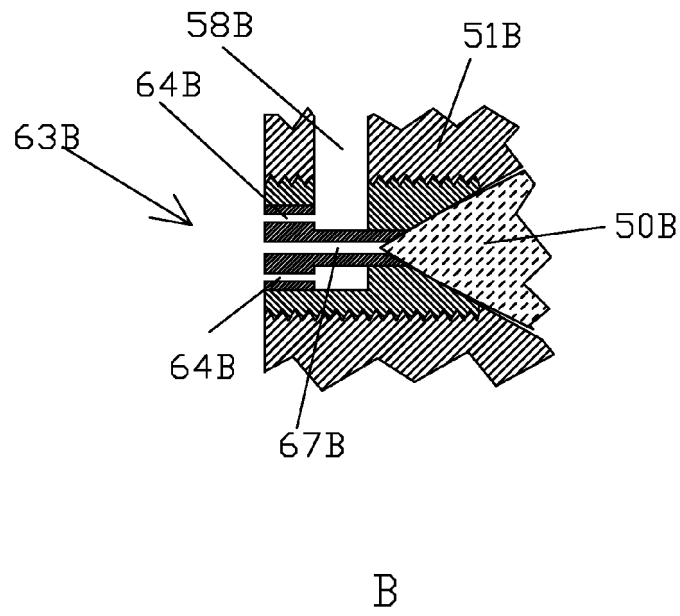
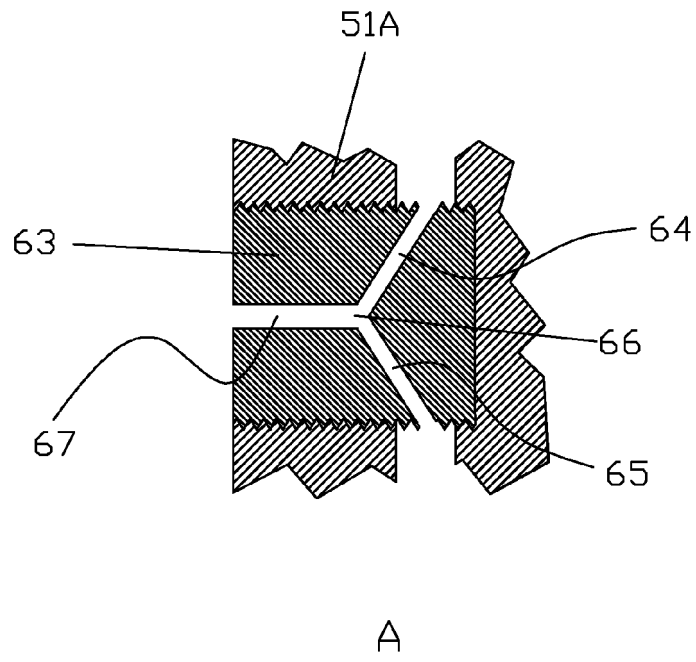

FIG.10

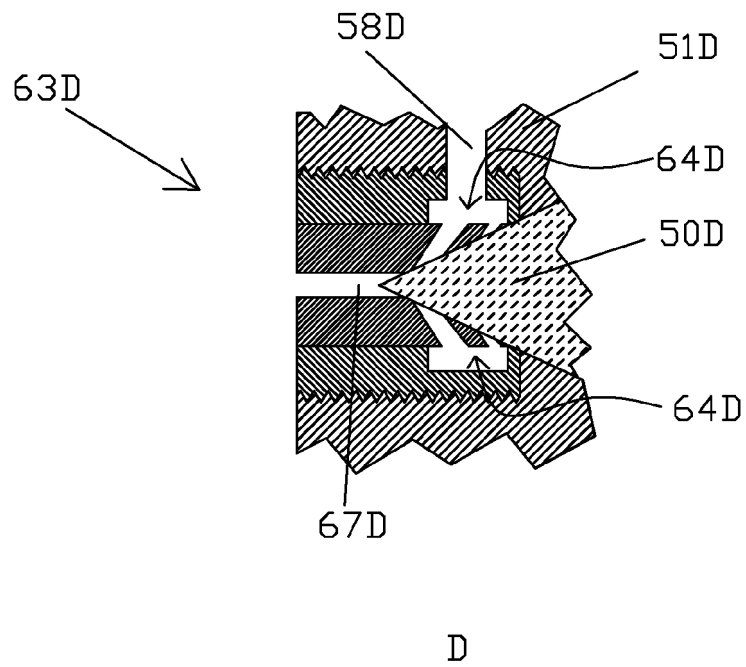
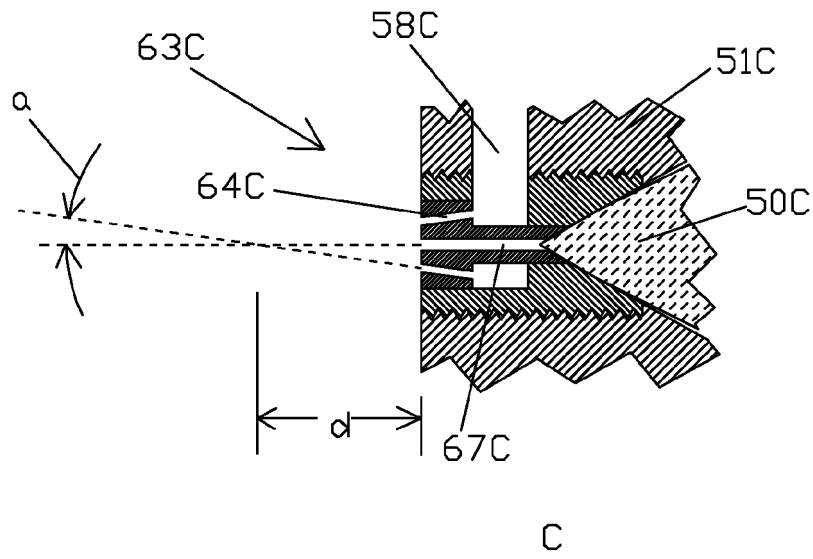
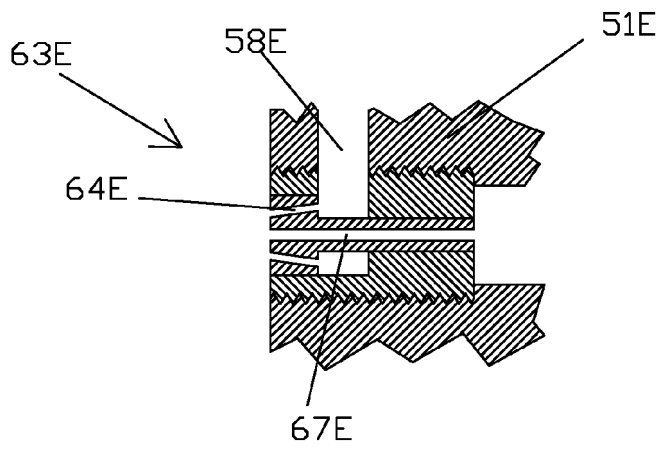
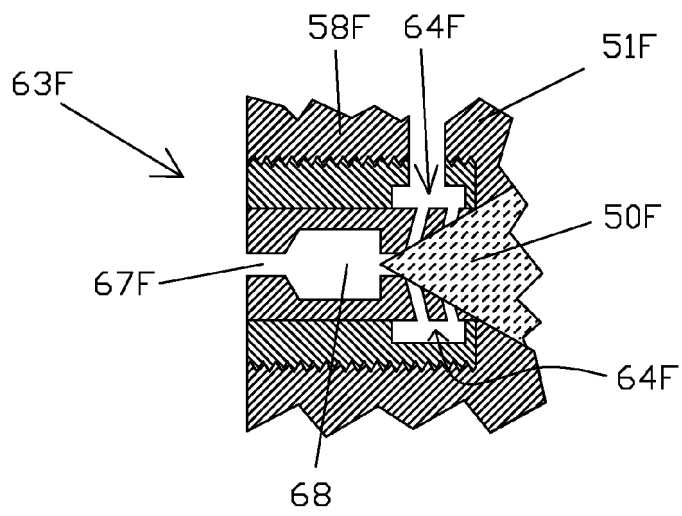

FIG.10



E



F

FIG.10

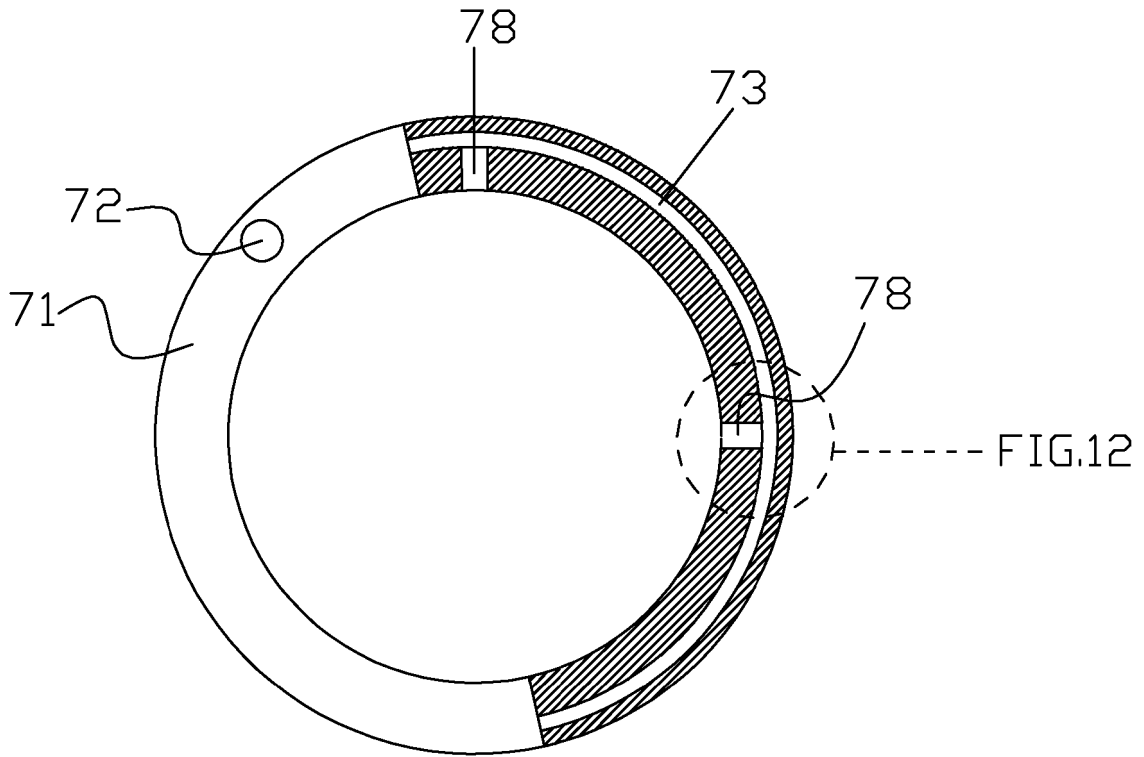

FIG.11

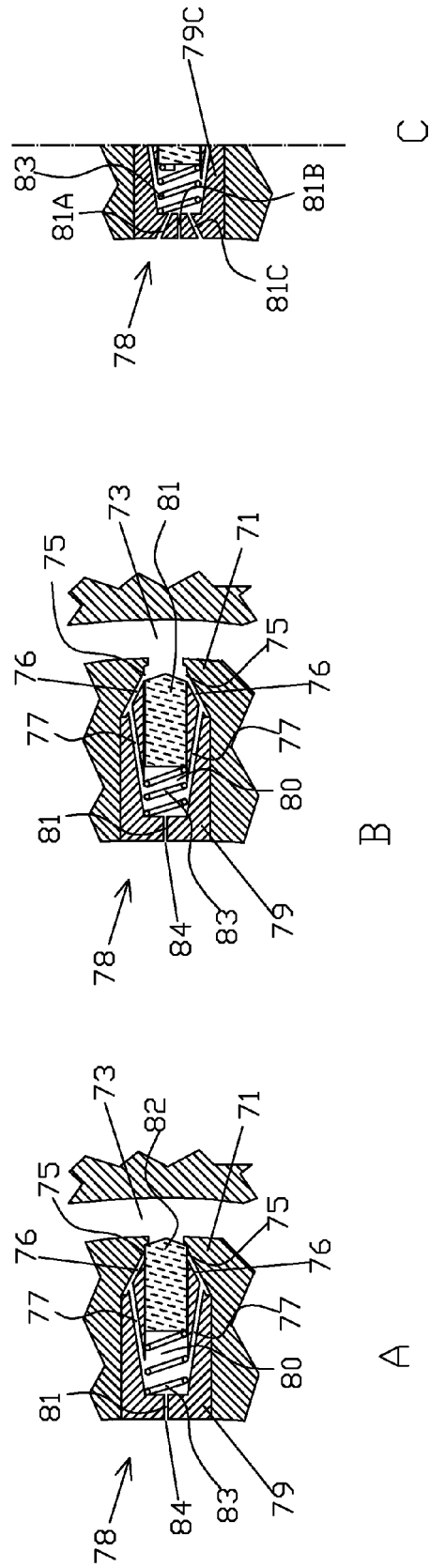

FIG. 12

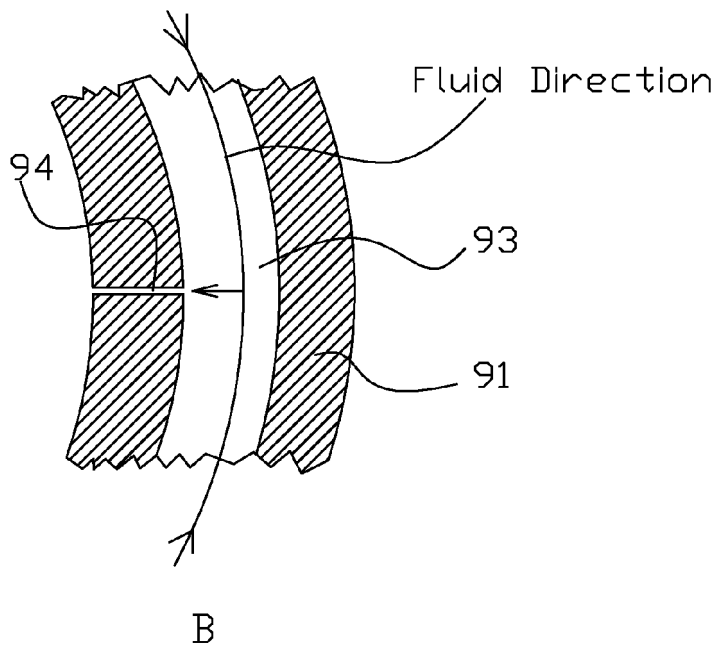
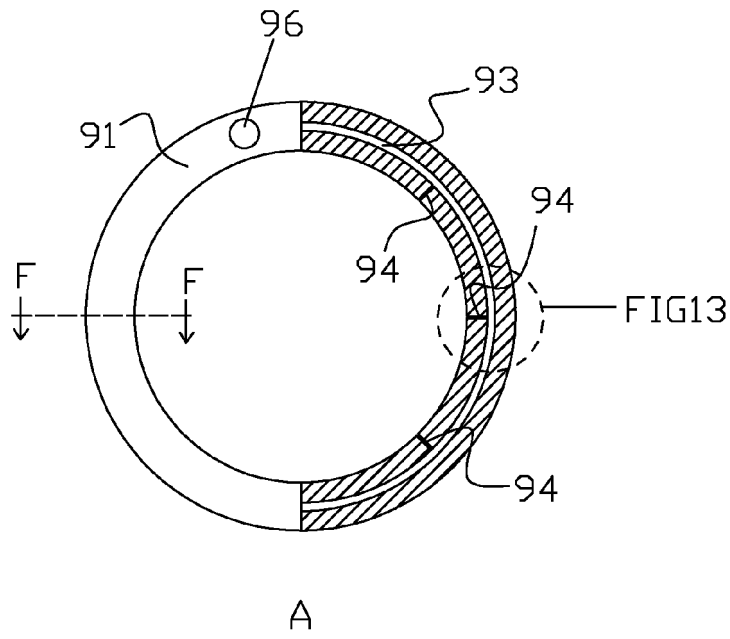
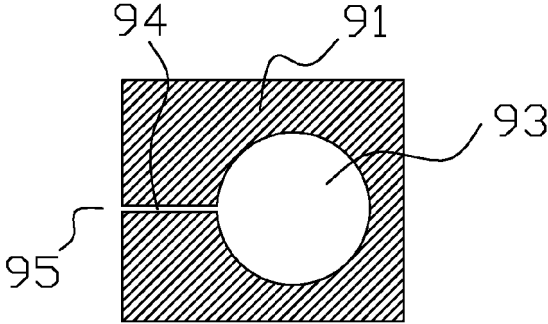
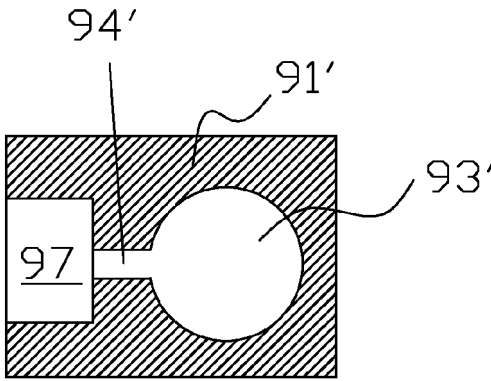

FIG.13



A



B

FIG.14

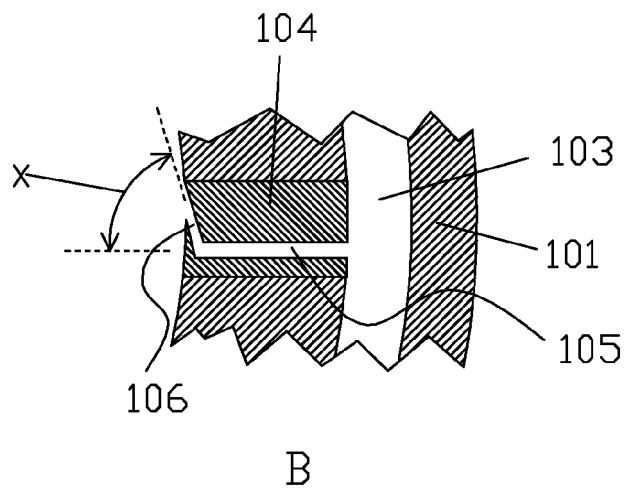
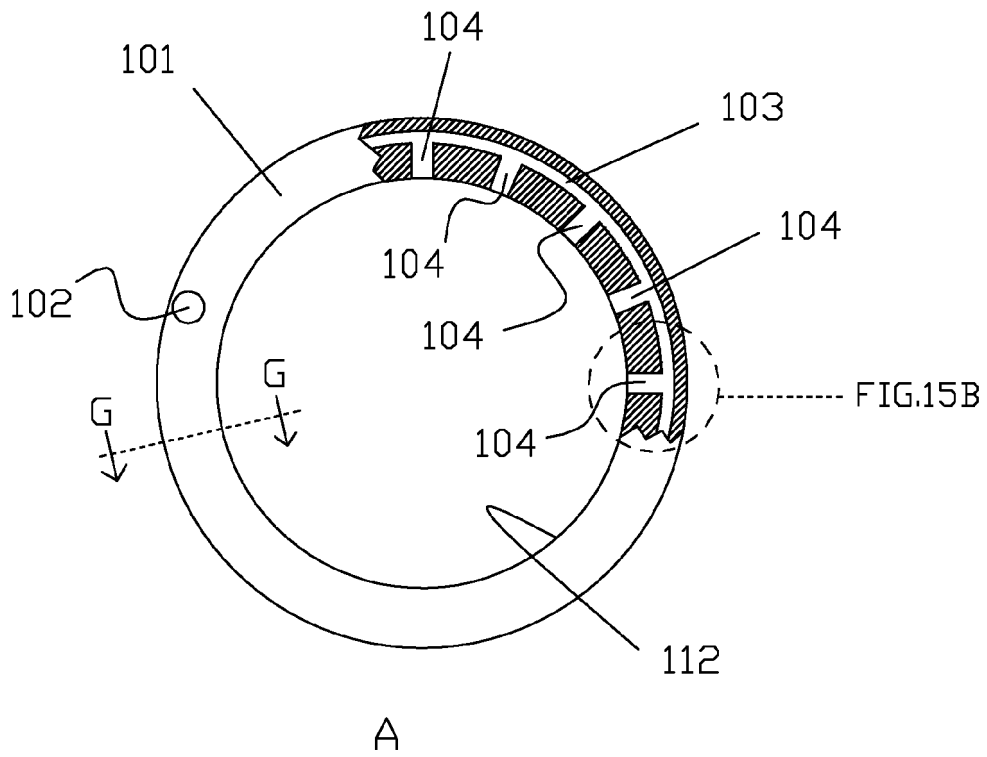

FIG. 15

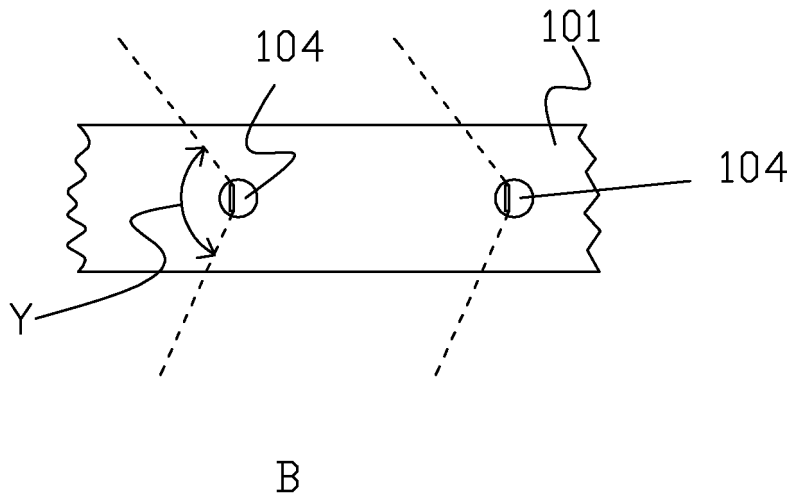
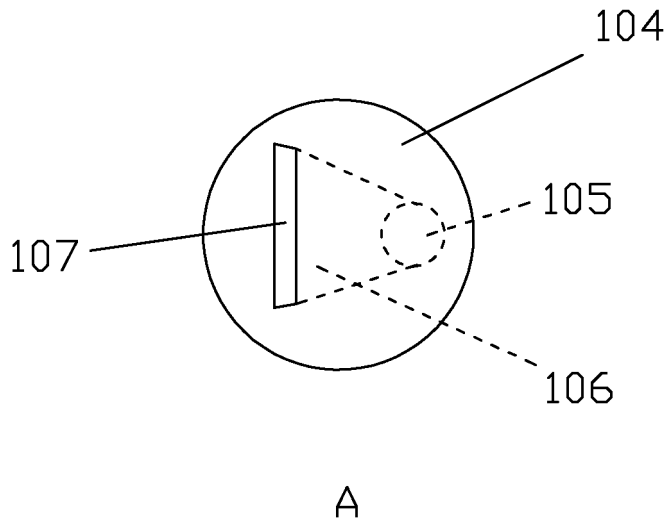
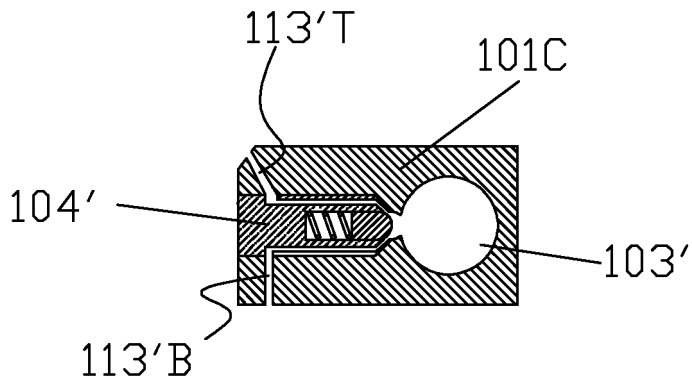
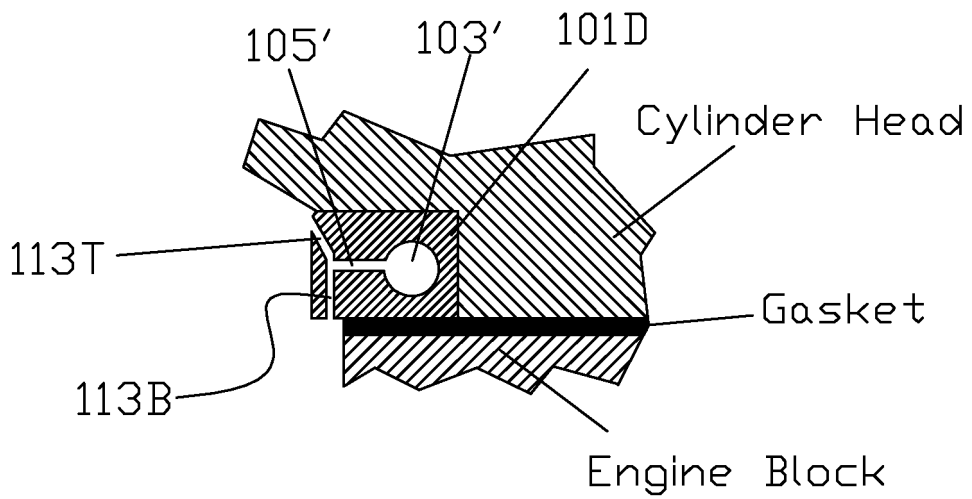

FIG.16



C



D

FIG.16

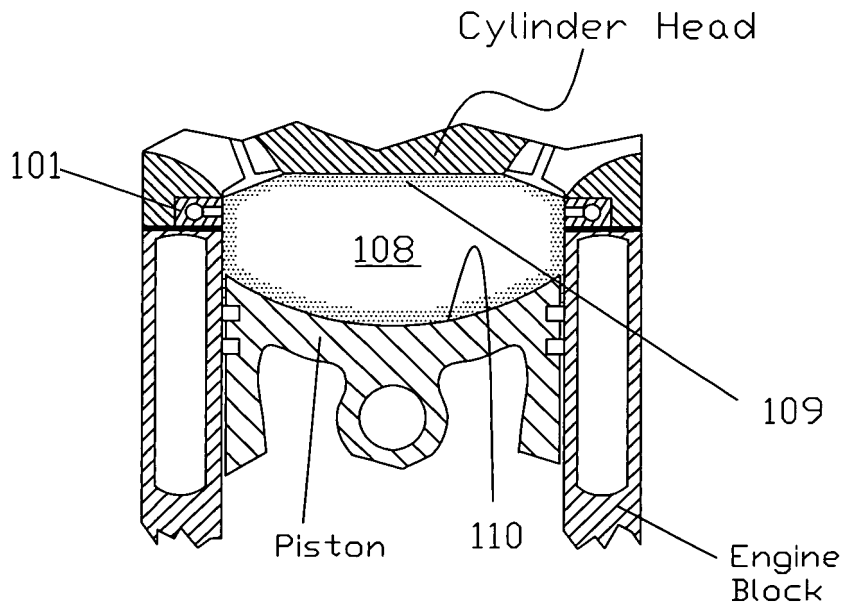

FIG 17

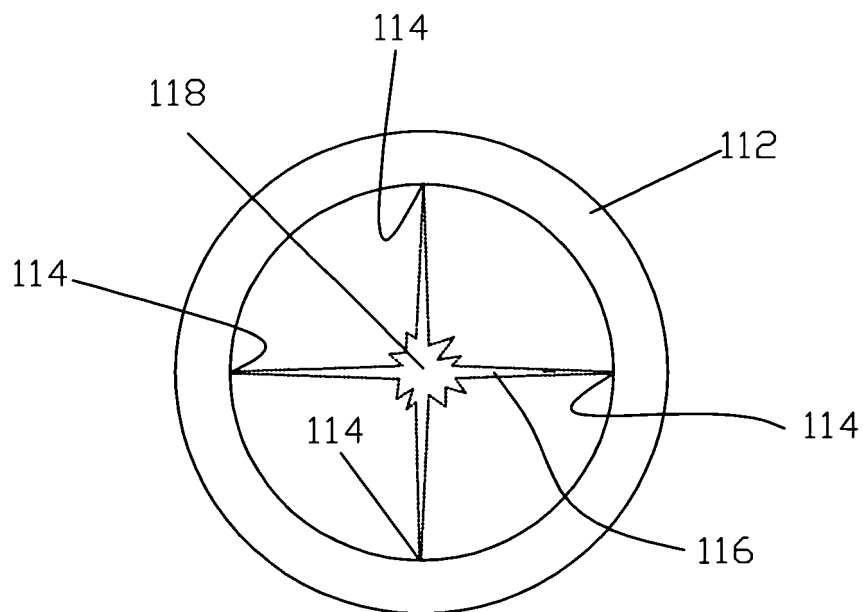

FIG.18

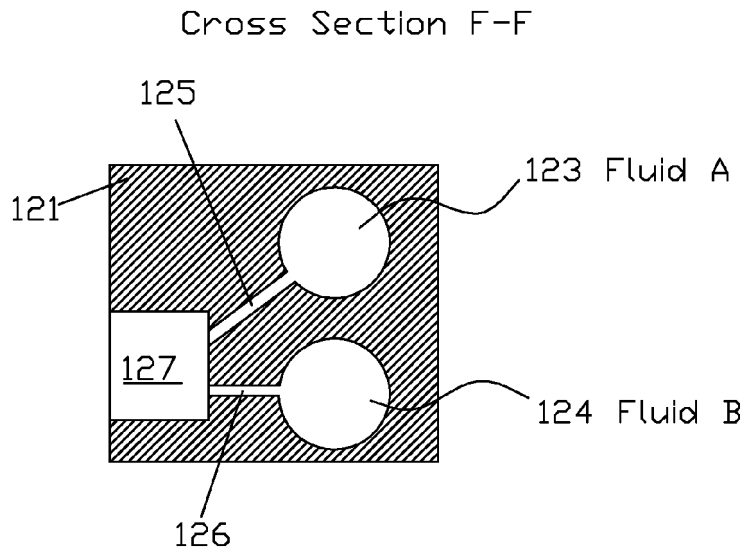

FIG 19

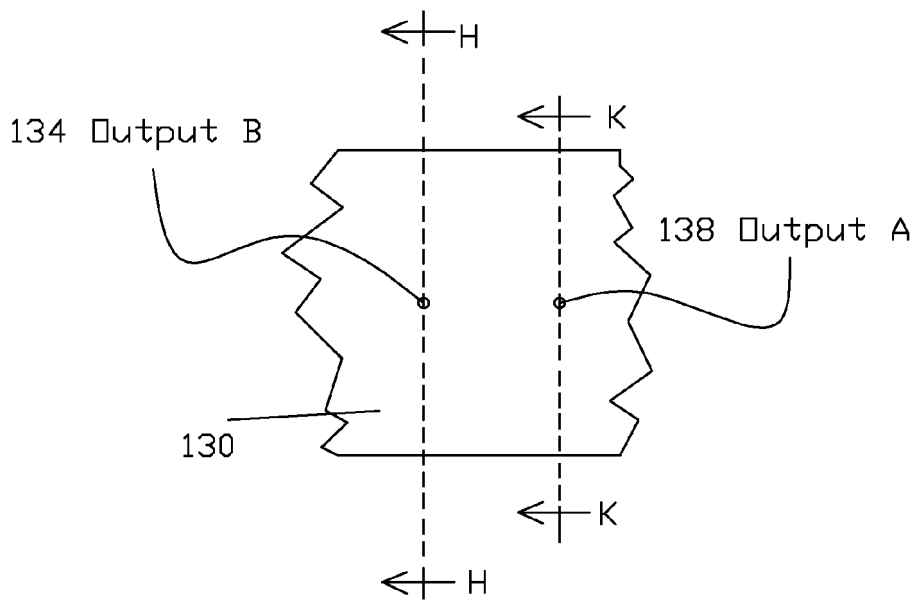

FIG.20A

Cross Section H-H

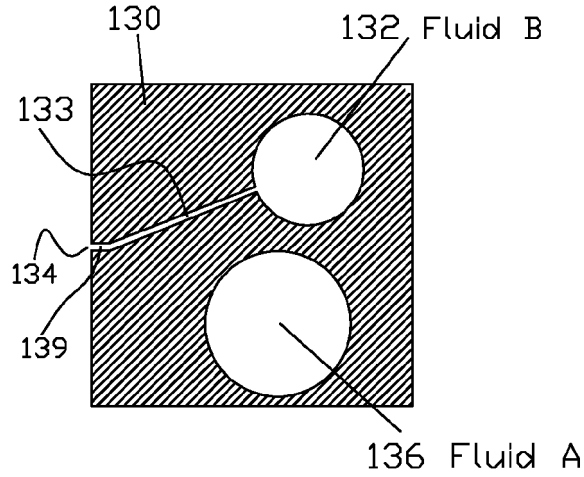

FIG.20B

Cross Section K-K

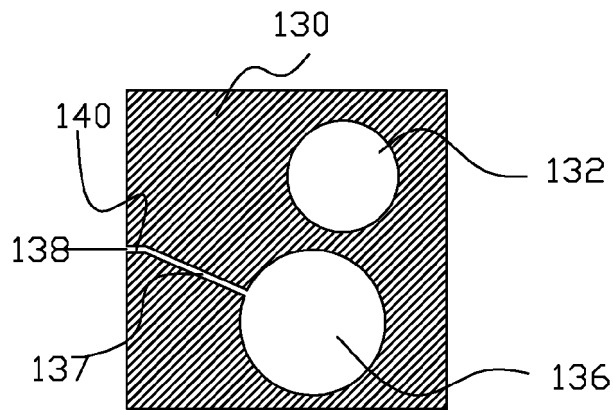

FIG.20C

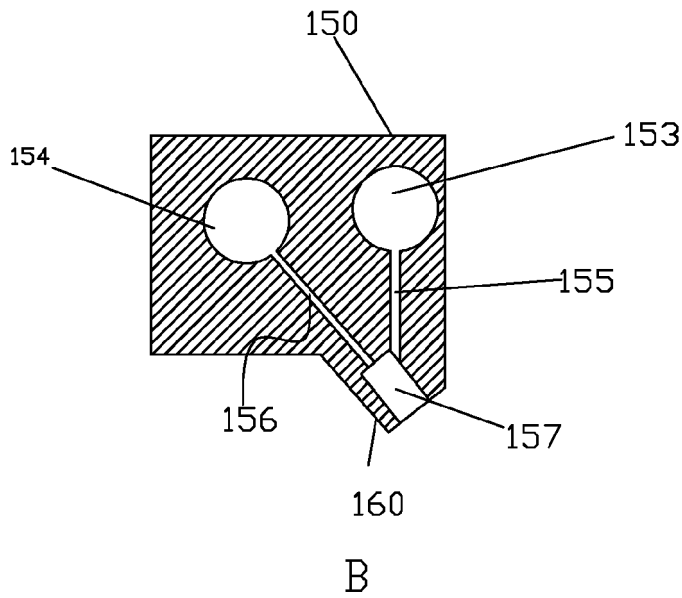
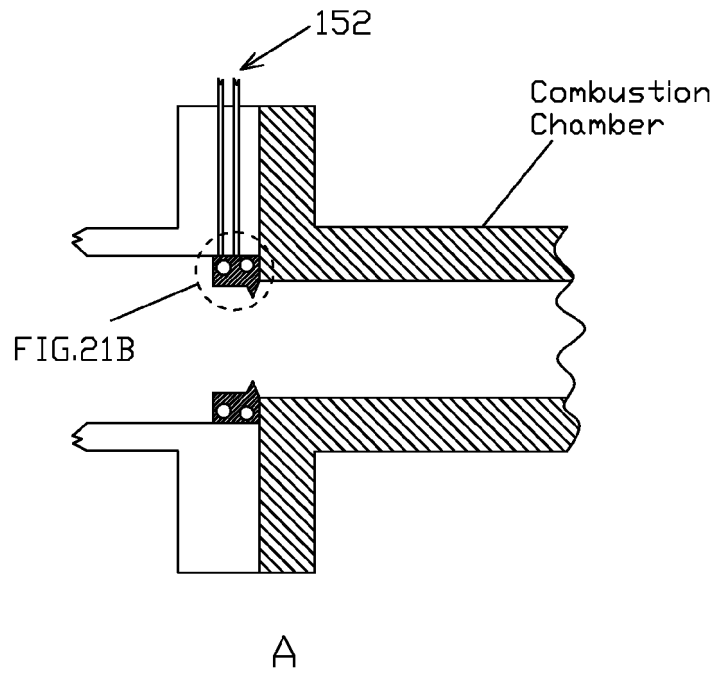

FIG. 21