

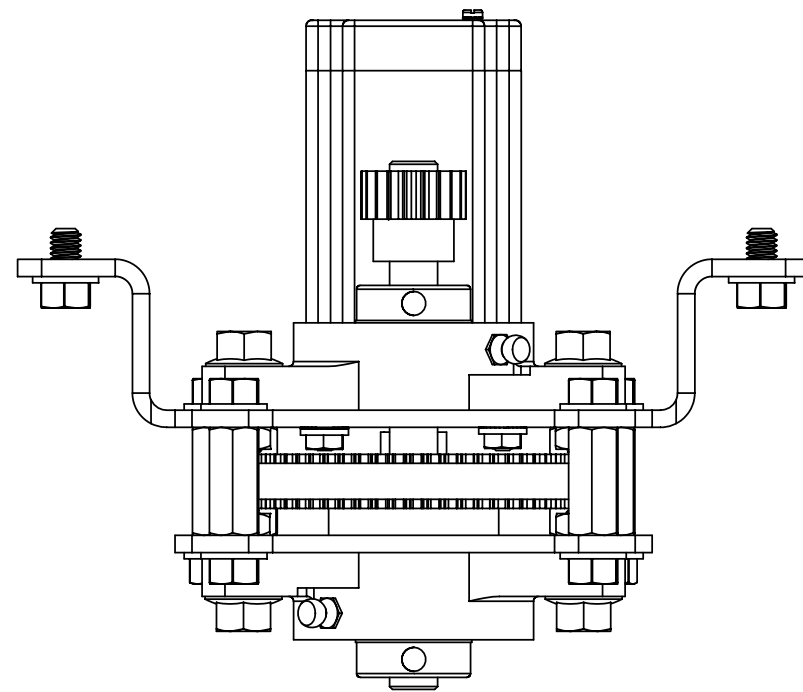

NOTE: USE THREADLOCKER AS RETAINING COMPOUND BETWEEN TIMING SPROCKETS AND SHAFT. ALSO APPLY BETWEEN GEAR AND SHAFT AT FINAL ASSEMBLY ONCE GEAR IS ALIGNED WITH GEAR RACK.

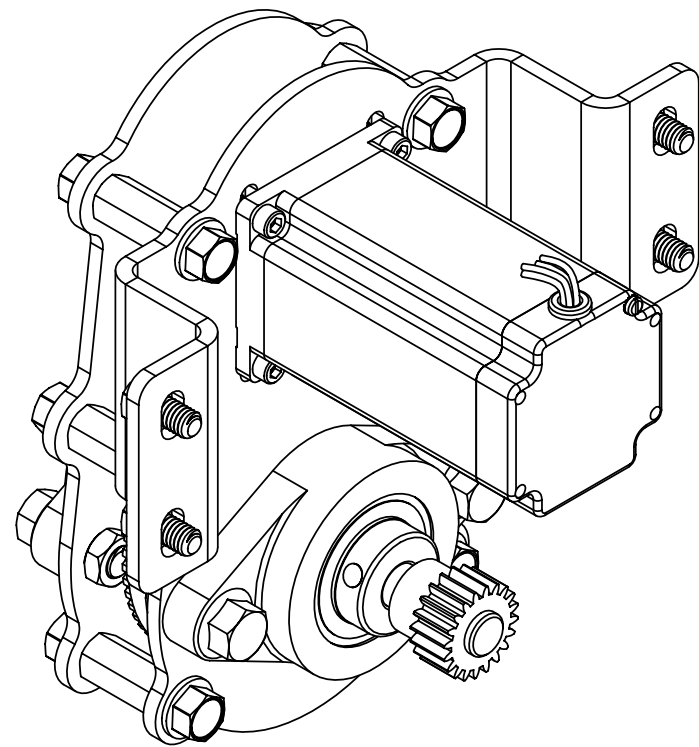

NOTE: BEARINGS ARE SELF ALIGNING. BEFORE ASSEMBLY, SLIP SHAFT THROUGH BEARING AND SQUARE SHAFT TO BEARING CASTING.

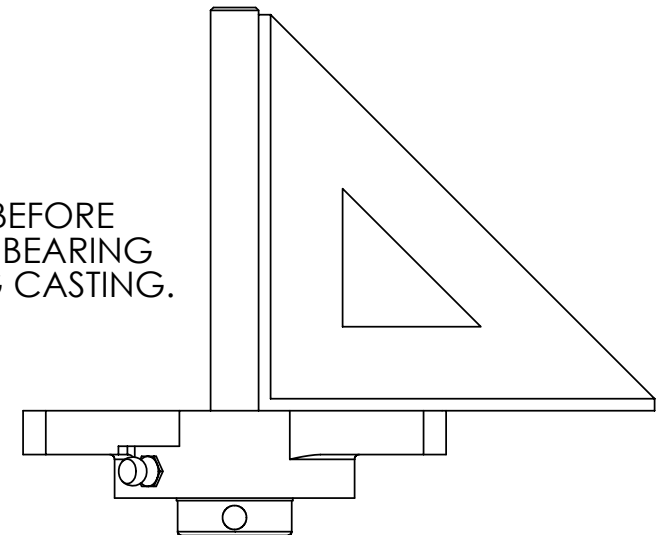

| | | | | | | |
|---|--------------------------------|-----------|----------------|-------------|----------------------|------------------------------------|
| TOLERANCES +/- UNLESS OTHERWISE SPECIFIED | | MACHINING | WELDING | FABRICATING | FINISH REQUIREMENTS | USED ON REFERENCE MACHINE/DRAWING: |
| | DECIMAL | .03, .005 | .13 | .06 | | |
| | ANGLE | | | | | |
| THE INFORMATION CONTAINED IN THIS DRAWING IS THE SOLE PROPERTY OF PRECISION PLASMA LLC. ANY REPRODUCTION IN PART OR WHOLE WITHOUT WRITTEN PERMISSION IS PROHIBITED. | | | | | | |
|   | SCALE: | 1:2 | SIZE: B | DATE | NAME | MATERIAL: |
| | UNITS: | INCHES | DRAWN | 7-9-17 | RWC | |
| | SOLIDS (Y/N): | Y | CHECKED | | | |
| PRECISION PLASMA LLC. | TITLE: MAGNUM 7 SIDE REDUCTION | | | | DRAWING NUMBER: | REV. |
| | | | | | MAG7 SIDE RED | SHEET 1 OF 1 |