

**Smart Factory, Integrated Approach
and Applications of Industry 4.0 in Pharma**

Ravi K,
Head IT & AI, Anthem Biosciences Group

ravi.k@anthembio.com

Tel: +91 9243555508

24th Nov 2018

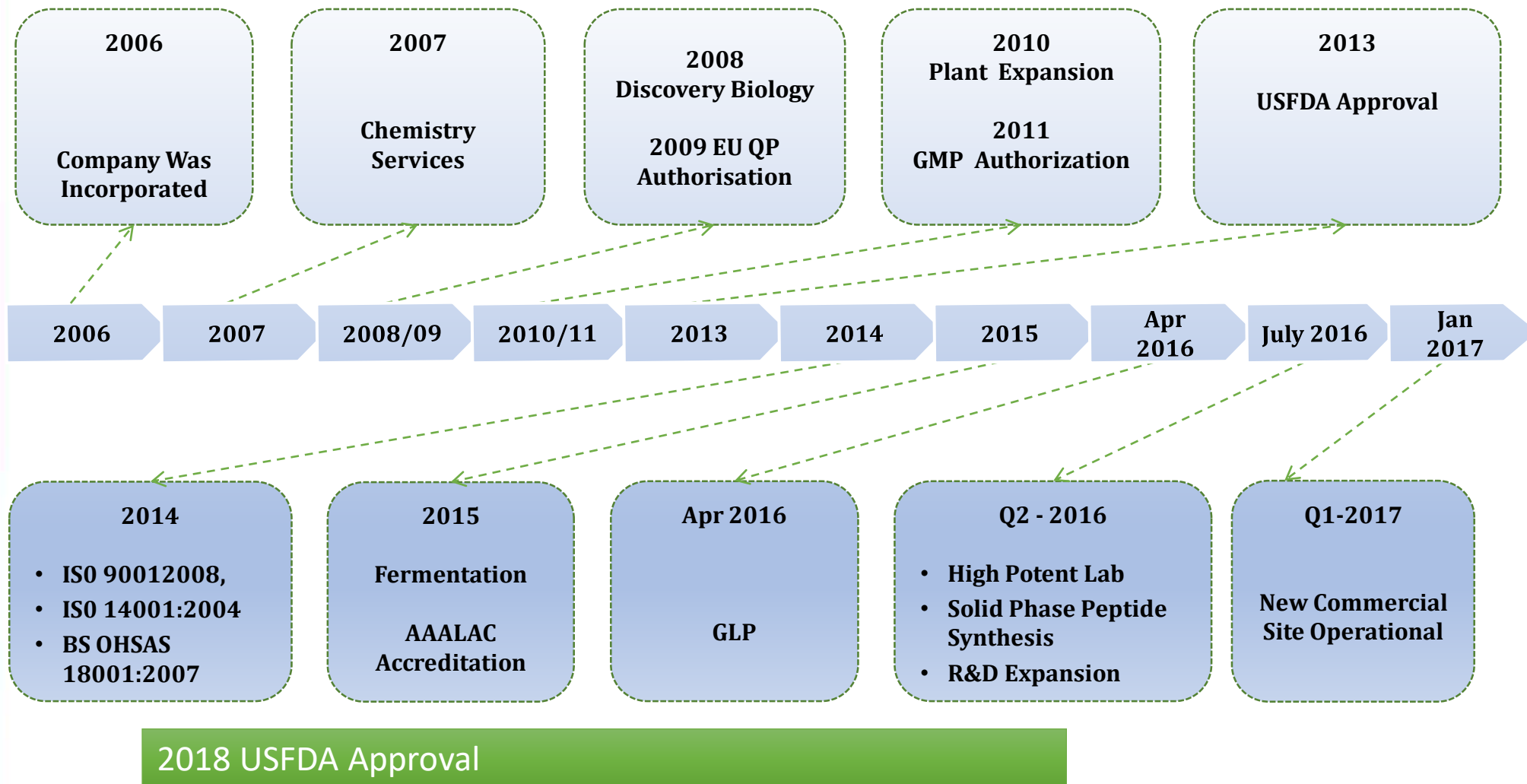

Digitalization of manufacturing through industry 4.0

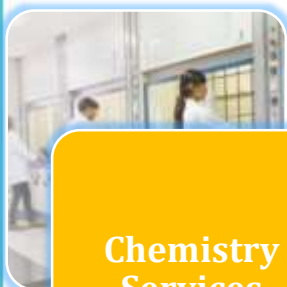

Chemistry Services

Medicinal Chemistry

Library Synthesis

- Natural product inspired virtual compound libraries

Custom Synthesis

Process Chemistry

DoE, QbD concepts

GMP Manufacturing

HiPo suites

Peptides (Solid Phase)

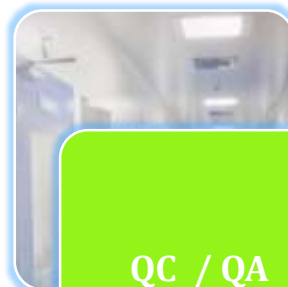

QC / QA

Method Development

Method Validation

API release testing

Stability Studies

Separation Science

Regulatory Support

- e-CTD filing
- Open/closed part DMF
- IND filing

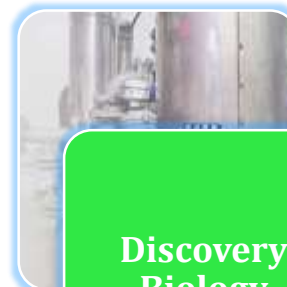

Discovery Biology

Platform technologies

Molecular Modeling

Preclinical Biology

Assay Biology

Microbiology

- In vitro studies
- In vivo Studies



Fermentation & Cell Culture Services

High density cell cultivation

Low, Medium & High pressure chromatography

Microbial & mammalian cell lines (of fungi, yeast, bacteria, actinomycetes, and mammalian)

Process development & scale up

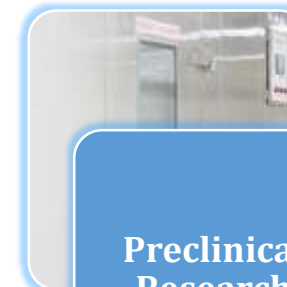

Preclinical Research

Preclinical Biology

Efficacy Studies

ADME Studies

Toxicity Studies

In vivo Pharmacology

Pharma Product Cycle

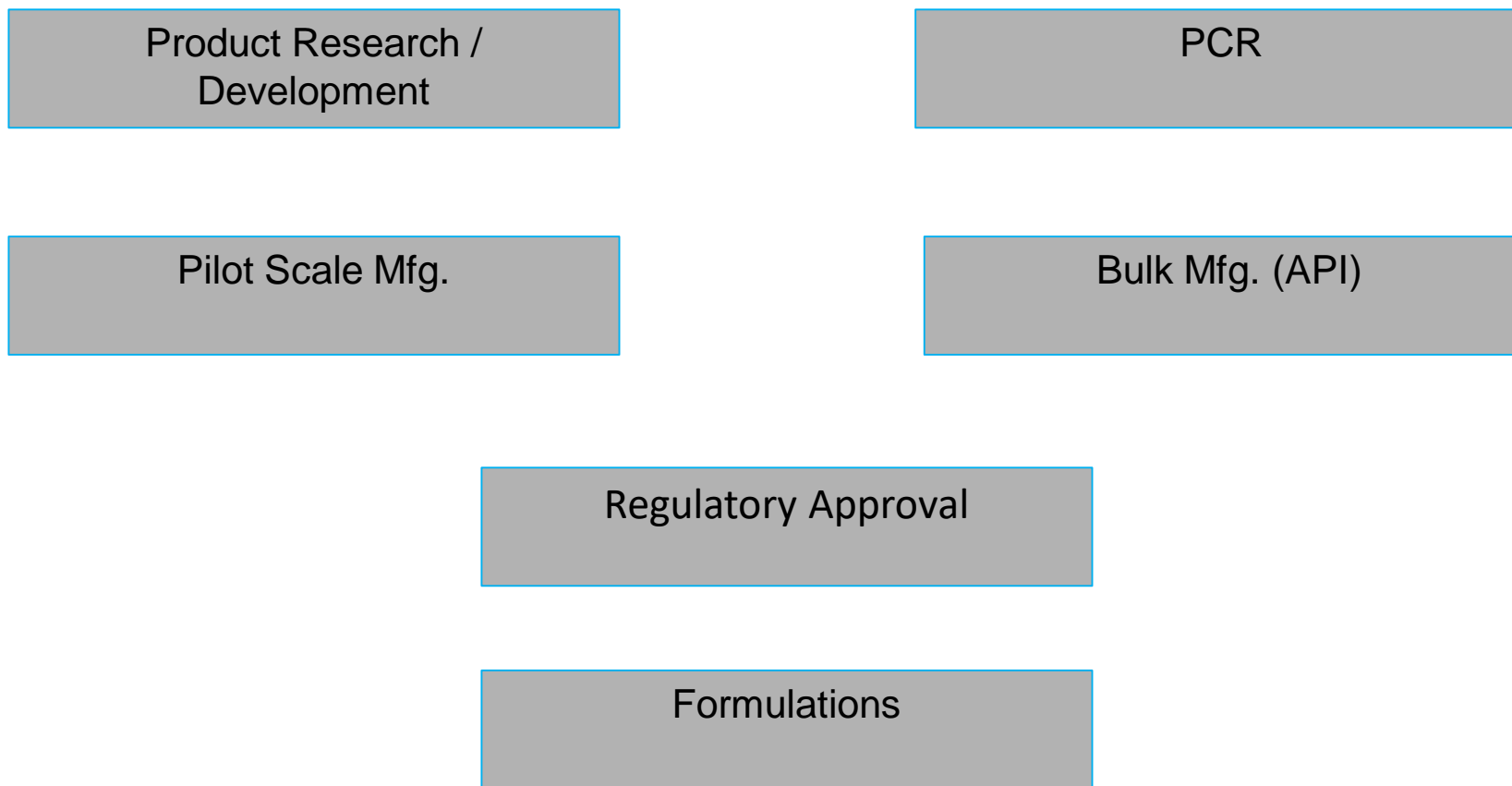

Digitalization of manufacturing through industry 4.0

Gap between manufacturing and Enterprise systems

L5

L4

L3

L2

L1

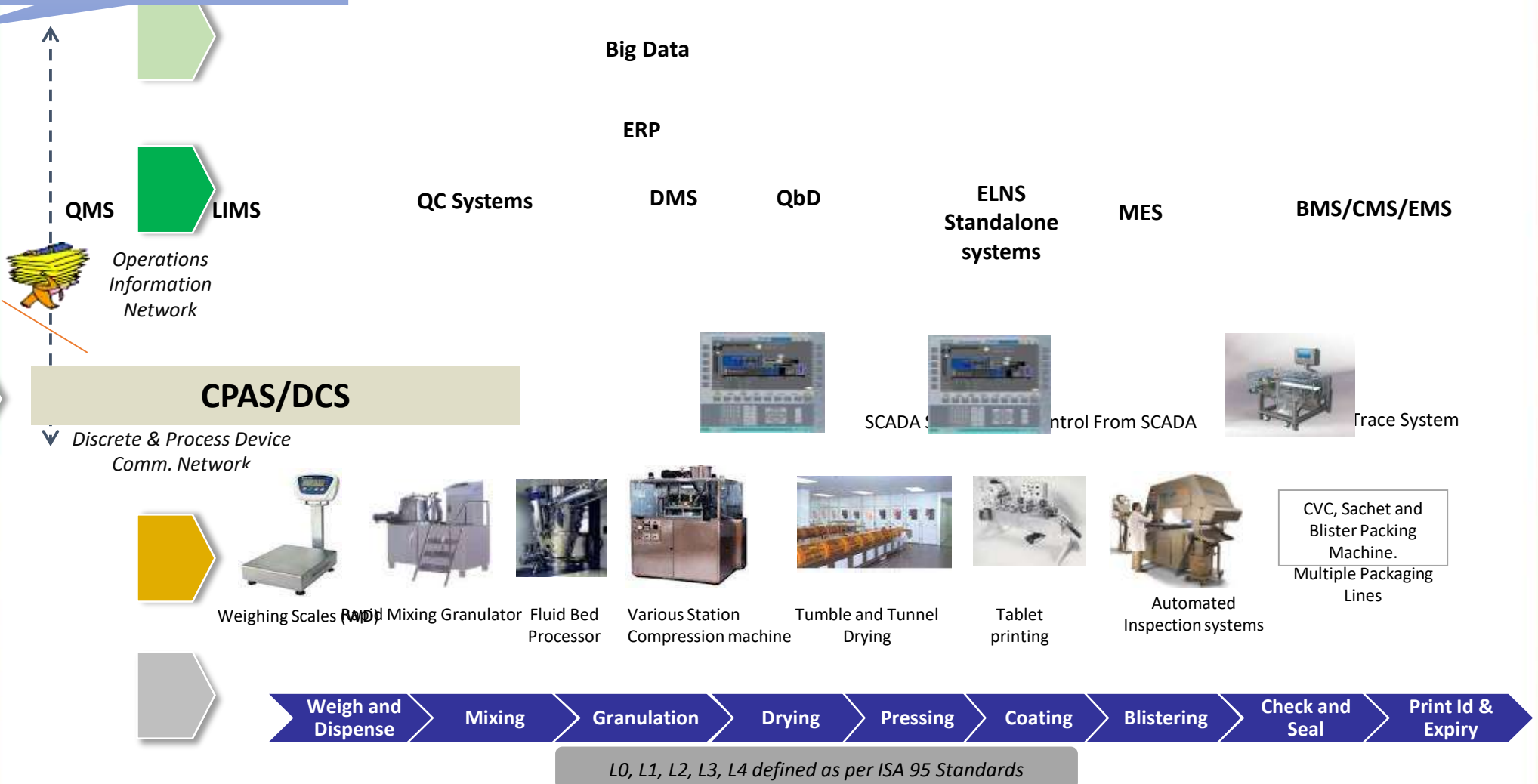

L0, L1, L2, L3, L4 defined as per ISA 95 Standards

Digitalization of manufacturing through industry 4.0

PHARMA Mfg. Flow



Digitalization of manufacturing through industry 4.0

Personalized Medicine

Without Personalized Medicine:

Some Benefit, Some Do Not

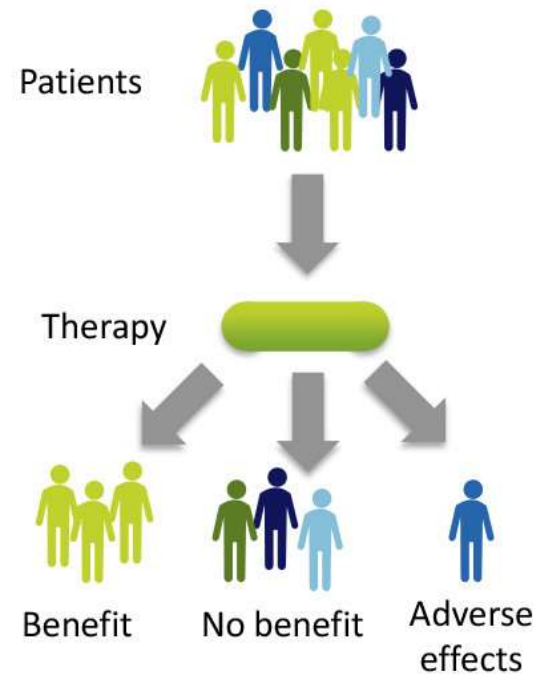

With Personalized Medicine:

Each Patient Receives the Right Medicine For Them

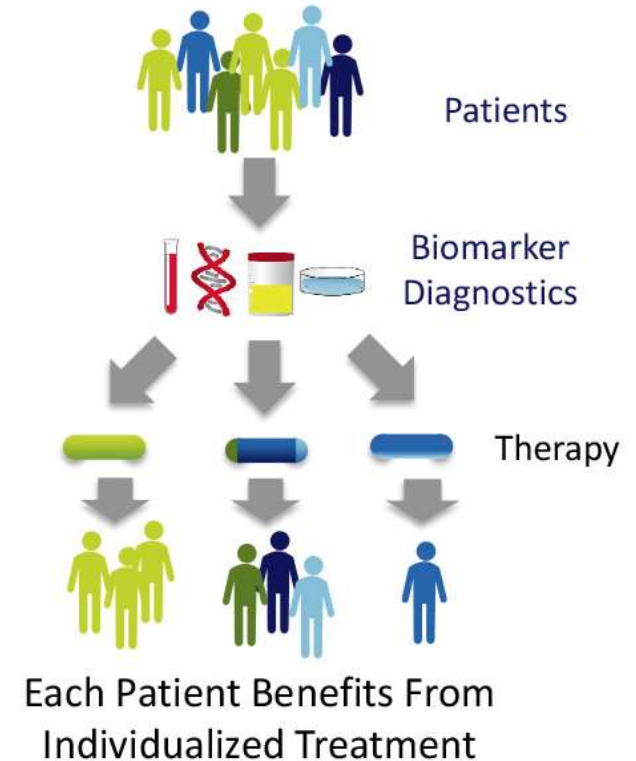

Biomarker is a measurable indicator of the severity or presence of some disease

Digitalization of manufacturing through industry 4.0

Manufacturing

- Production
- Testing
- Rework
- Inventory
- Shipping

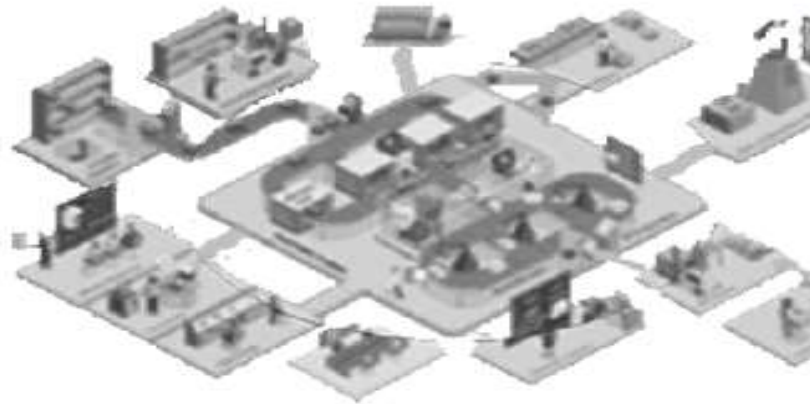

Information Workers

- Management
- Production Supervisor
- Quality Department
- Sales
- Marketing

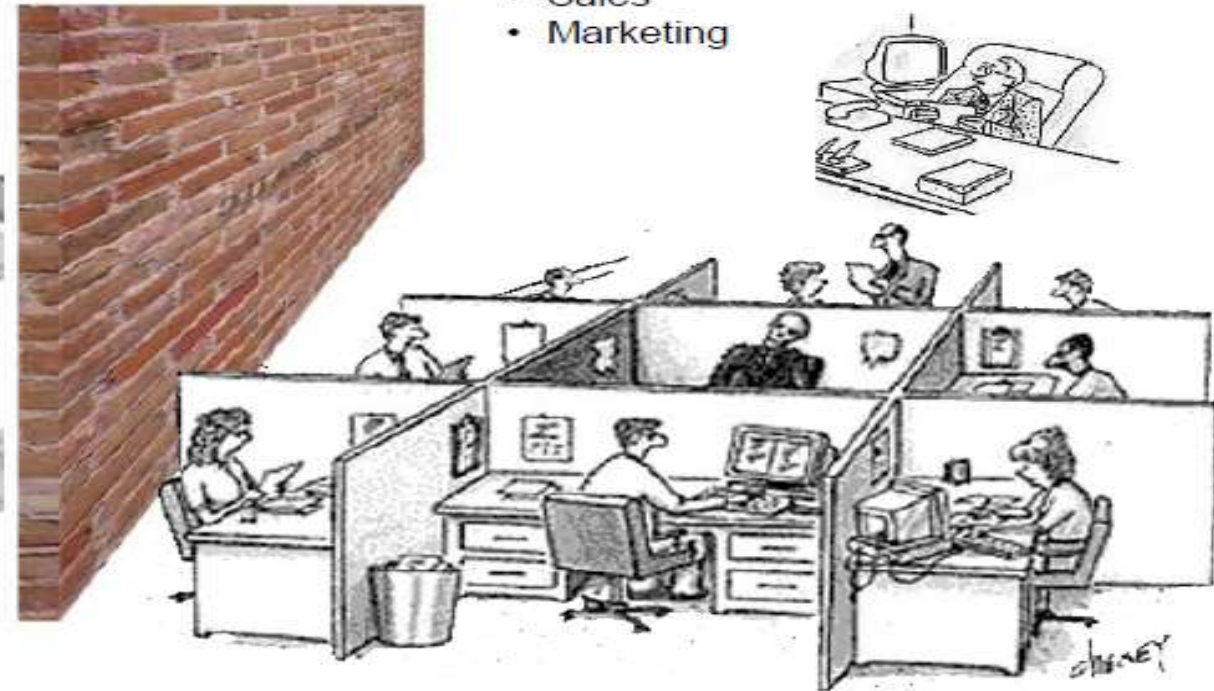

Digitalization of manufacturing through industry 4.0

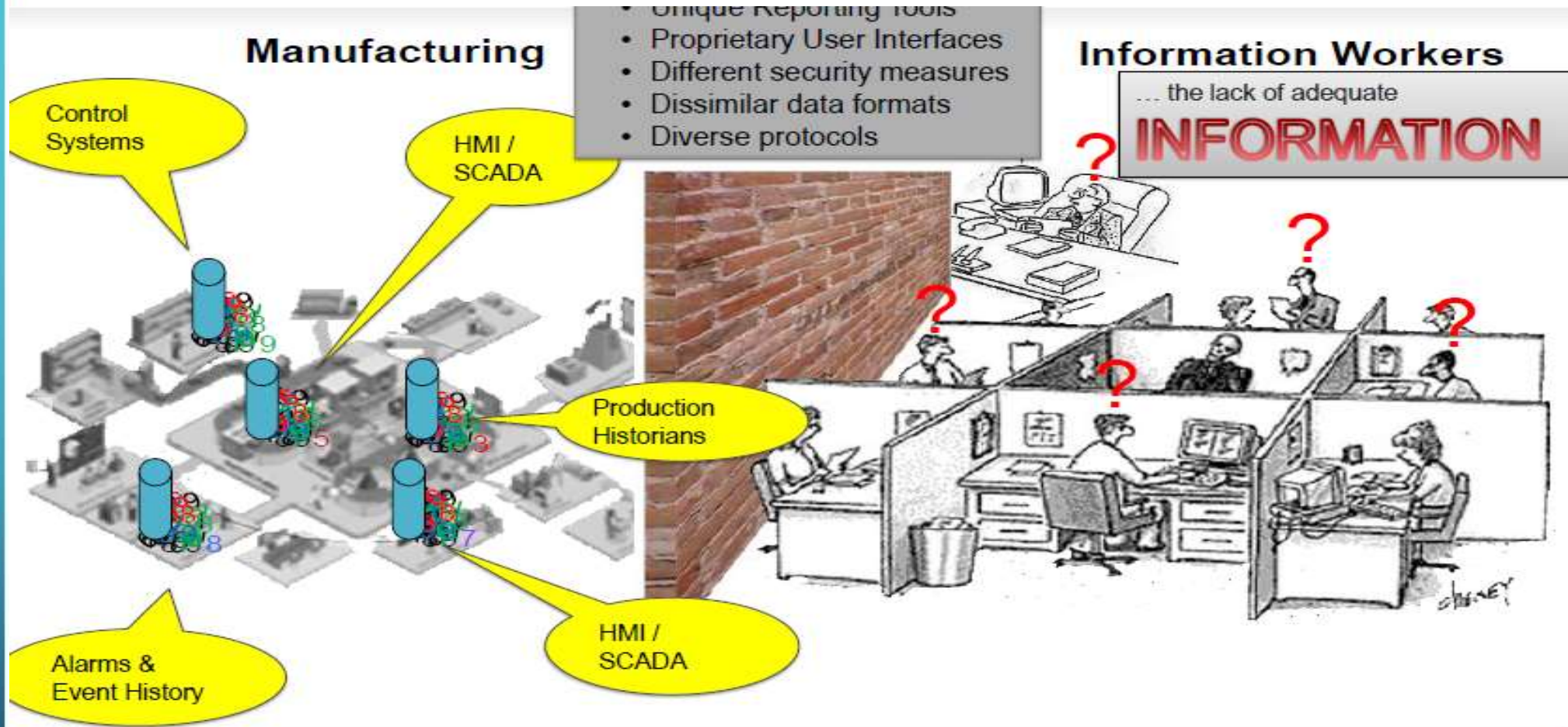

Digitalization of manufacturing through industry 4.0

Challenges

Affordability

Legacy Equipment's
& Applications

Capabilities

Integrations

Compliances

Safety Regulations

Security Concerns

Ecosystem availability

Support & Services

Sourcing

Interoperability

Change

Digitalization of manufacturing through industry 4.0

SMART FACTORY OBJECTIVES

Productivity

Product Quality

Equipment Control

Supply Chain

Digitalization of manufacturing through industry 4.0

Technology Transformations

Technology Innovations

Collaborations

Networking of Devices

Consumerization

Customers/Suppliers

Employees

Regulatory

Previously, “technology was more a barrier than an enabler.” The current technology revolution, “will allow manufacturers to get closer to their supply chains and plants.”

Digitalization of manufacturing through industry 4.0

Technology Trends

Continuous Mfg.

Personalized Mfg

Predictive & Prescriptive
Analysis

3D Printing

Big Data & Analytics

Simulation

AI, Augmented, VR

Intelligent Devices

Paperless Mfg.

Digitalization of manufacturing through industry 4.0

Traditional Mfg. VS Continuous Mfg..

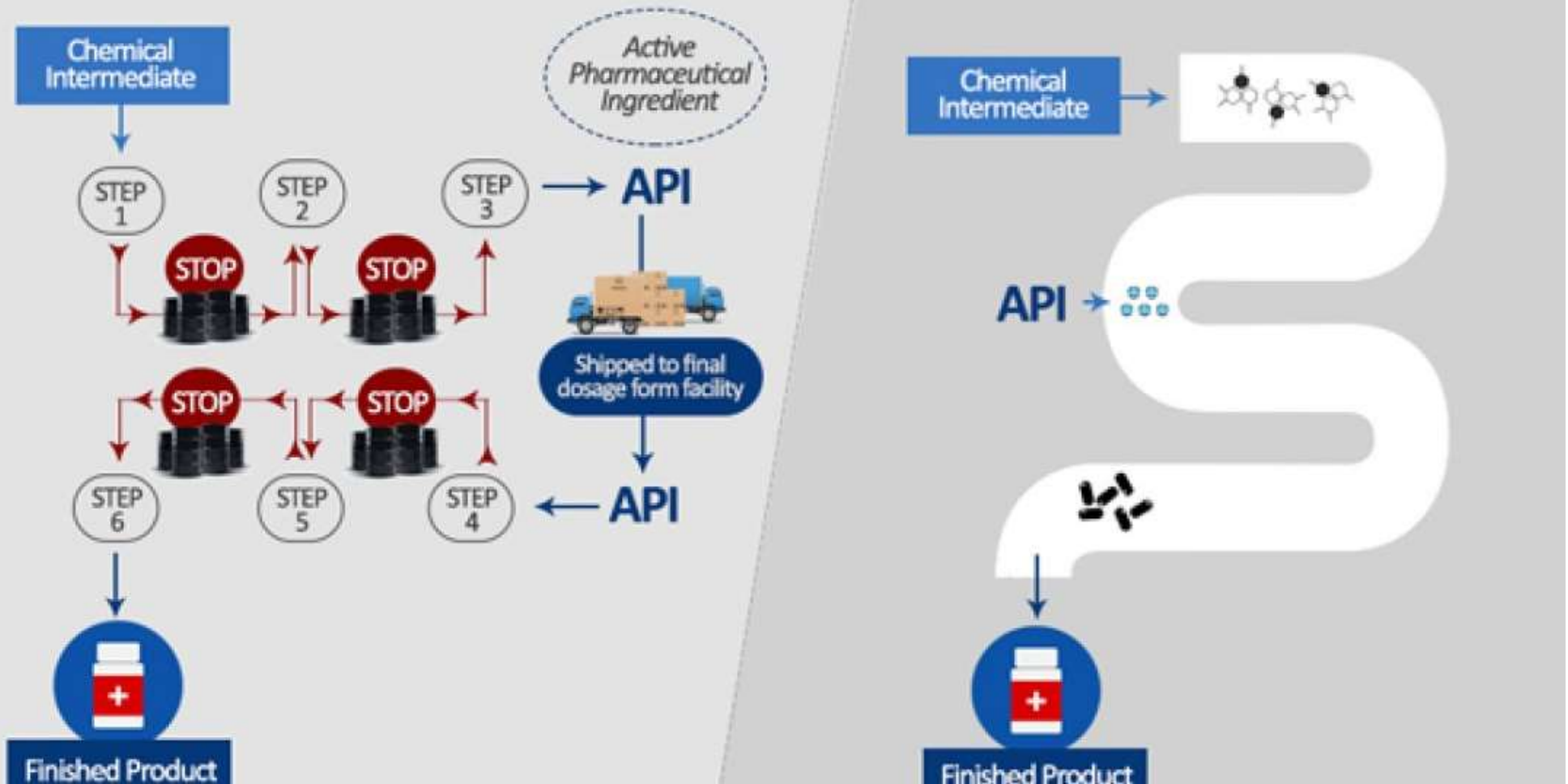

Digitalization of manufacturing through industry 4.0

The factory of the future

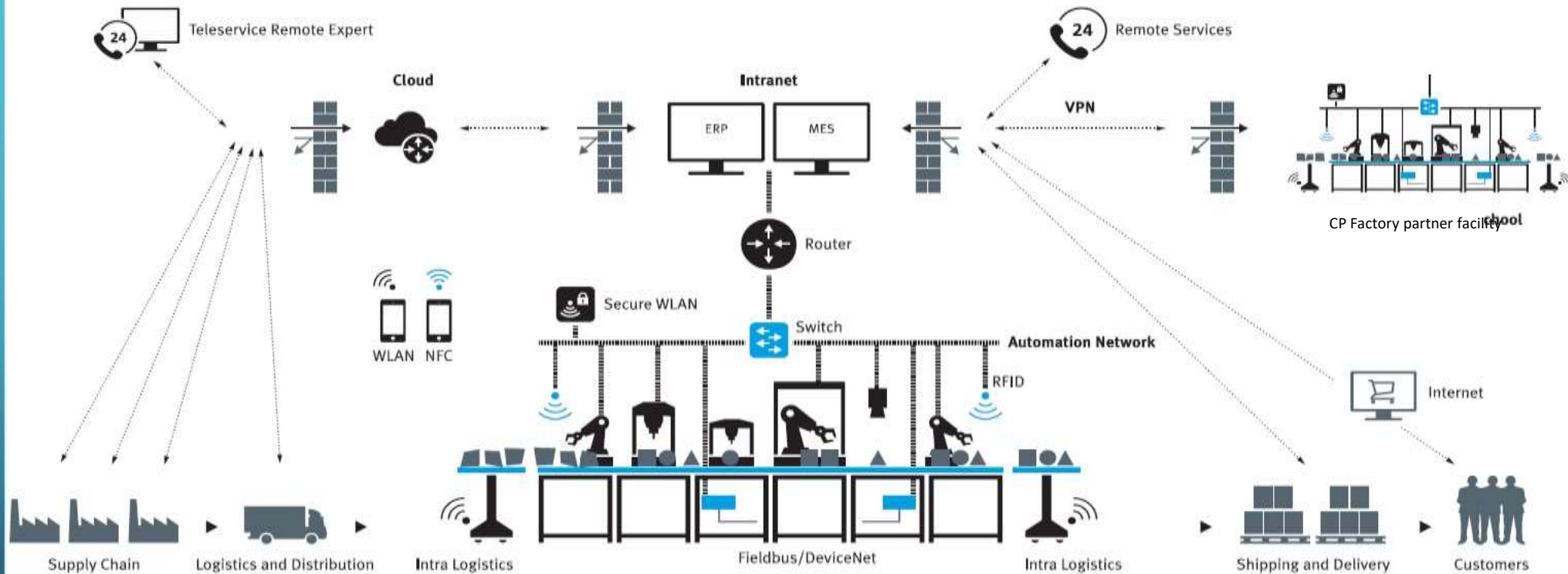

Digitalization of manufacturing through industry 4.0

Mechatronic systems are turning into cyber-physical systems

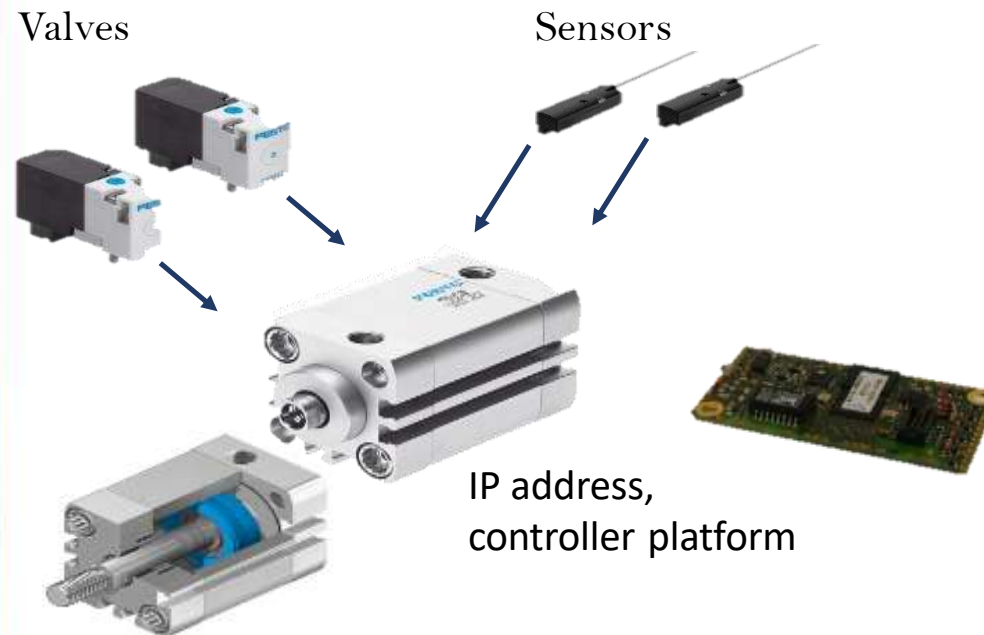

The Internet of things

+ IP capacity

Cyber-physical systems

- + Internet communication
- + machine-to-machine communication
 - Wireless communication
 - Semantic description

Integrated systems

- + sensors, actuators
- + integrated intelligence

Physical objects, devices

Digitalization of manufacturing through industry 4.0

Paperless Office

Integrated work flow
R&D, Pilot Plant, Bulk Mfg.

ELN ,E-BMR

Integrated LIMS

Integrated Automation

Integrated Alarm &
Condition Monitoring

Personalized Alarm
Management

Integrated QMS

Integrated IT & OT

Electronic

Continuous Mfg.

PAT

Continuous Quality
Verification

Smaller Foot Print

Improved yield with better
quality

Significant savings

Reducing waste

Flexible Mfg.

Single use & Flexible Mfg.

Reduced CIP

Cost Savings

Efficient Usage

Compliances

Digitalization of manufacturing through industry 4.0

M2M , M2P, M2L

M2M Communication

Condition Monitoring

Modeling, Predictive &
Control(MPC)

Reliability

Machine to People
Interaction

Planning

Batch Progress

Deviations/Quality Aspects

Work Flow

Electronic Review

Intelligent

Reporting

ANTHEM SMART FACTORY ARCHITECTURE

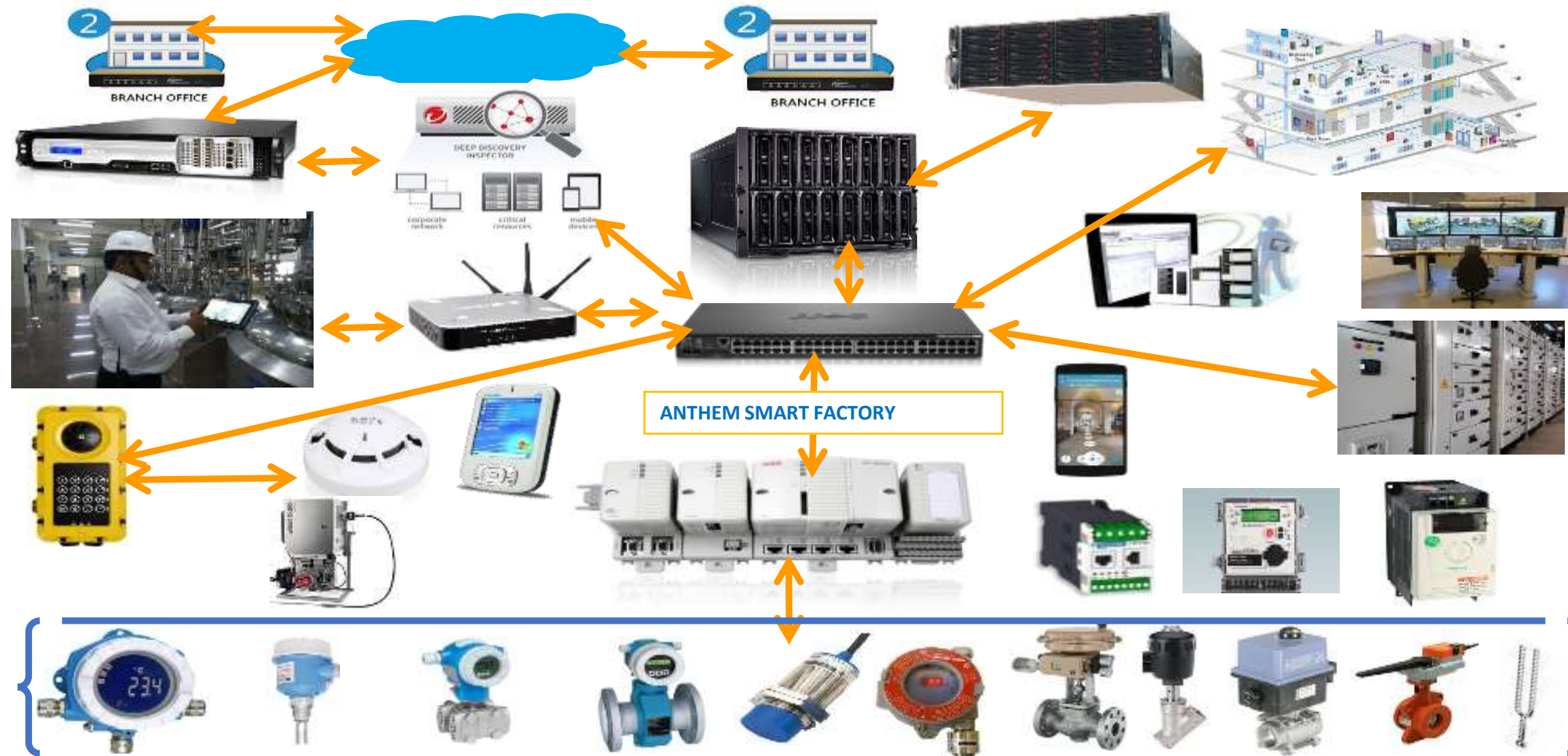

Digitalization of manufacturing through industry 4.0

Advantages of Integrated Automation & Virtualization

Operator Convenience

Operator Safety

High Availability

Reliability

Integrated Control

Regulatory compliance

Significant Savings

Remote Control

Easy to collaborate

E-audits

Integrated Alarm
Management

Less Maintenance
Efforts

Integrated Automation



API



PEMS

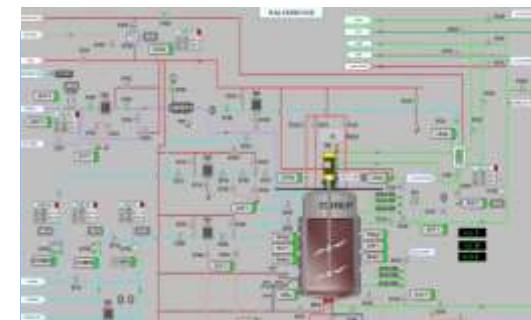

Fermentation
Upstream

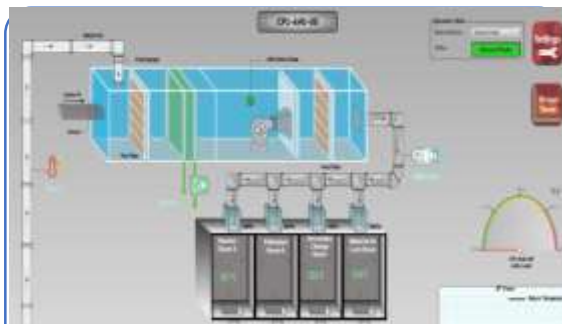

BMS

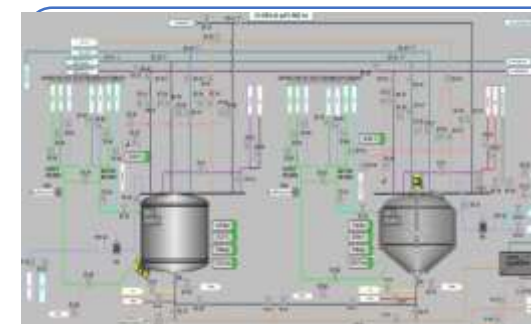

Fermentation
Downstream



Labs



Knowledge Portal



Quality Assurance



Utility Data & BMS

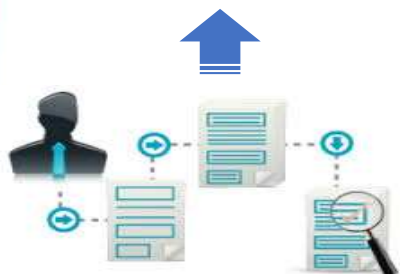

DTS/DMS



Control Process Automation Systems

LIMS/QC



Digitalization of manufacturing through industry 4.0



Digitalization of manufacturing through industry 4.0

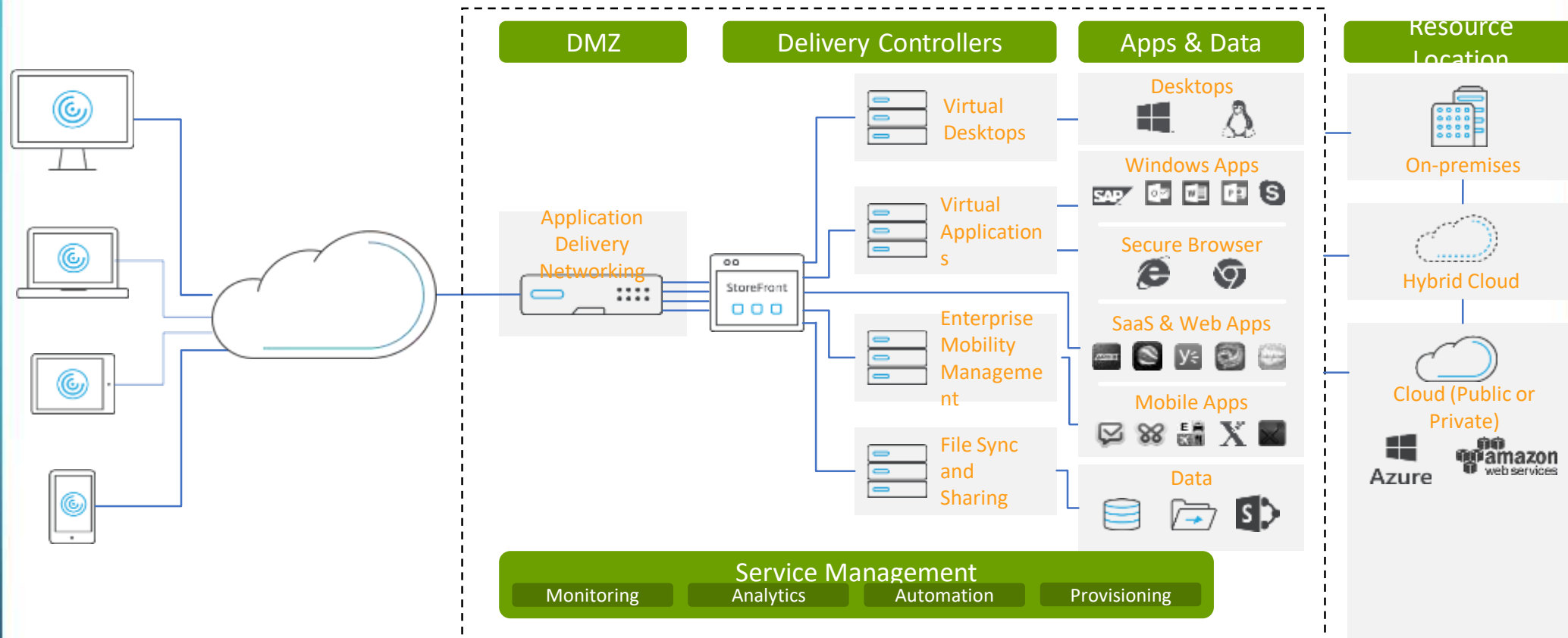

Digitalization of manufacturing through industry 4.0



Digitalization of manufacturing through industry 4.0

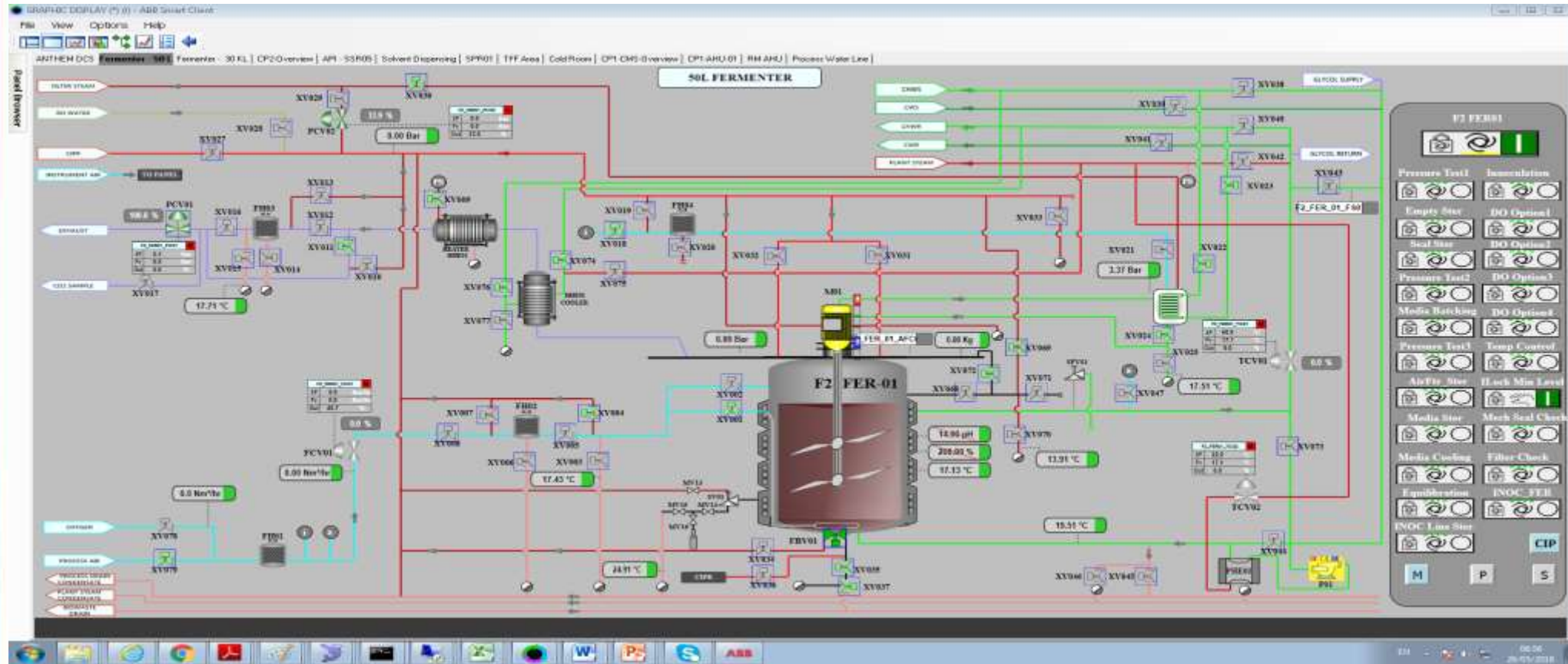

Digitalization of manufacturing through industry 4.0

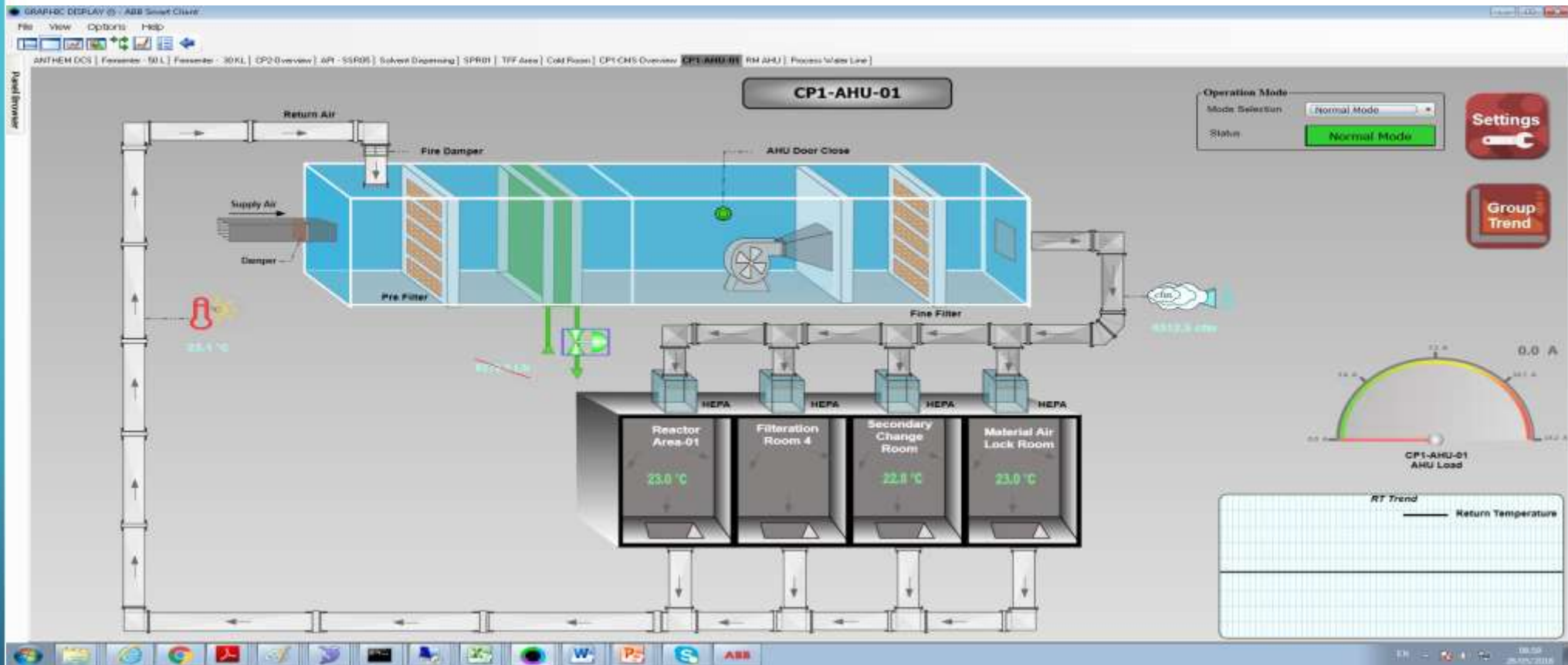

Digitalization of manufacturing through industry 4.0



Digitalization of manufacturing through industry 4.0



Endress + Hauser
People for Process Automation



zenitel



Digitalization of manufacturing through industry 4.0

Thank You!

Q&A