

Product Details (All Models)

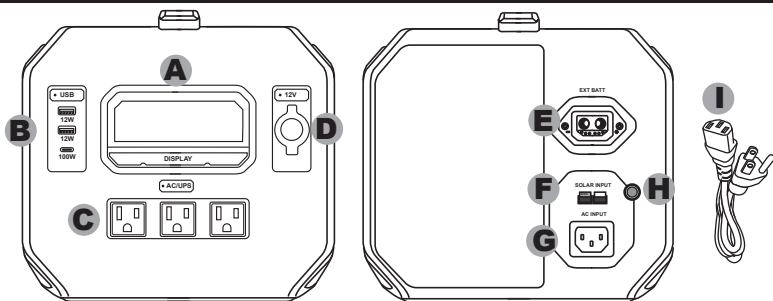

- A. Intelligent LCD screen:** See details at right
- B. USB power button and ports**
- C. AC/UPS power button and outlets**
- D. 12V power button and accessory socket**

- E. Extension port:**
Extension Pack sold separately
- F. Solar input**
- G. AC input port:**
Use AC charging cord (included)
- H. Input overload protection switch**
- I. AC charging cord**

Intelligent LCD Screen (All Models)

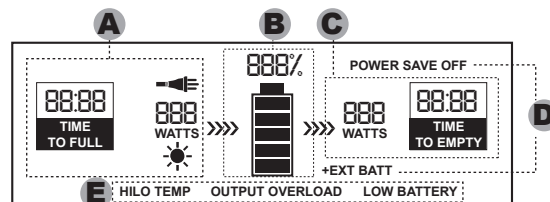

- A. Charging Input Indicators**
 - Time to fully charge (in hours)
 - AC or solar charge detected
 - Input wattage
- B. Fuel Gauge Indicators**
 - Percentage of available battery power
 - Battery graph fuel gauge
- C. Power Output (Usage) Indicators**
 - Total output wattage
 - Time remaining to empty at current output
- D. Special Function Indicators**
 - POWER SAVE OFF (details on Page 5)
 - +EXT BATT (details on Page 3-4)
- E. Warning Indicators**
 - HI TEMP/LO TEMP
 - OUTPUT OVERLOAD
 - LOW BATTERY

Quick Start Guide

- 1.** Connect to AC outlet, solar panel, or both to fully charge unit:

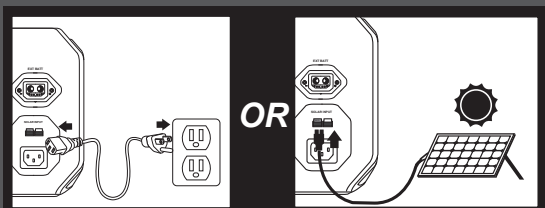

- 2.** Turn on outputs (USB, AC, and 12V ports) and connect device(s):

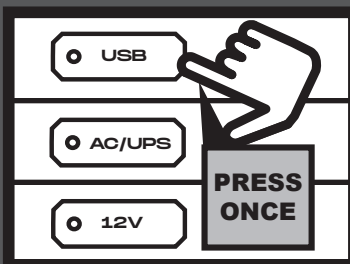

A 3 second delay may occur before power is delivered to your device.

- 3.** Turning on UPS/Power Save Off mode:

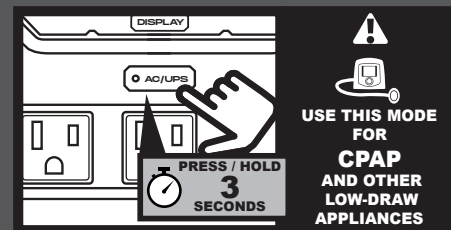

For more detail, refer to "UPS" or "Power Save Off" Mode section in this manual.

Getting Started: Charging your Battery Generator

- ⚠ BEFORE YOU START:** See "Safety Information" section for important precautions. Please conform to all safety precautions in the guide. Keep this guide in a safe place for future reference.
- ⚠ IMPORTANT - CHARGE BEFORE USE:** Fully charge your Battery Generator before using it and/or storing it. While recharging from an AC outlet, your Battery Generator should be located near an easily accessible outlet. The charger is designed to maintain the battery in a healthy state.
- ⚠ IMPORTANT -** The Battery Generator must be connected to a grounded AC outlet (3 prong outlet) to ensure safety when charging the product and used in UPS mode.
- ⚠ IMPORTANT:** The Battery Generator should be placed in a dry, well ventilated area with at least 6 inches of space on all sides for proper ventilation.

The Battery Generator can be charged from grid power (AC) or solar energy (solar panels). When it is being charged and discharged (used to power your items) at the same time:

- If the input power (charging the Battery Generator) is greater than the output power (used to power your items), the intelligent LCD screen will show the "Time to Full".
- If the input power (charging the Battery Generator) is less than the output power (used to power your items), the intelligent LCD screen will show the "Time to Empty".
- The LCD screen stays on during charging but it can be turned off by pressing the DISPLAY button below the screen.

If your Battery Generator is fully discharged (0% available power), the intelligent LCD screen will be completely dark. This screen will illuminate as soon as the Battery Generator is connected to power, letting you know that the unit is charging, and will continually display the growing power status as the Battery Generator charges.

Getting Started (cont'd)

Charging your Battery Generator from an AC outlet

Estimated Charge Time: ~2 hours to full (750/1000) / ~3 hours to full (1500)

NOTE: The ~2 hour charge time may vary depending on your AC outlet power and the climate (Battery Generator may charge more slowly in very high or low temperatures).

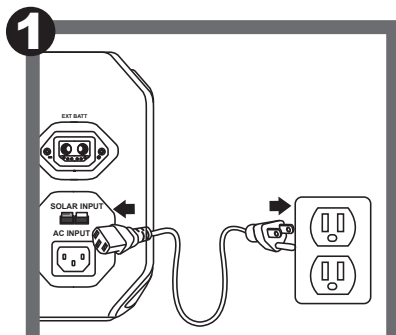

1 Plug the AC charging cord into the AC input on the back of the Battery Generator. Plug the other end of the cord into an AC outlet.

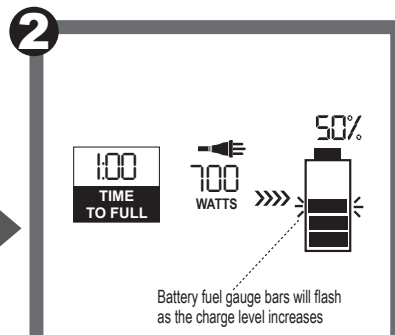

2 The Intelligent LCD Screen will show the AC icon, the input power and the battery charge level. (Press the DISPLAY button to turn off this screen if desired)

Keep charged for immediate use

You may keep the Battery Generator plugged into your AC outlet for maintenance charging. The internal charger is designed to optimize power without overcharging the battery. We recommend keeping your Battery Generator charged so it provides maximum power when you need it.

Your Battery Generator also includes a UPS mode, which requires that it is plugged into an AC output (Refer to UPS section for more information.).

Charging your Battery Generator from a solar panel

Estimated Charge Time (with 200W panel connected): ~8 hours to full (750/1000) / ~12 hours to full (1500)

NOTE: The built-in MPPT solar control will automatically optimize the voltage and current to provide the most efficient charging to the Battery Generator.

NOTE: The actual charge time may vary depending on solar exposure and the climate (Battery Generator may charge more slowly in very high or low temperatures).

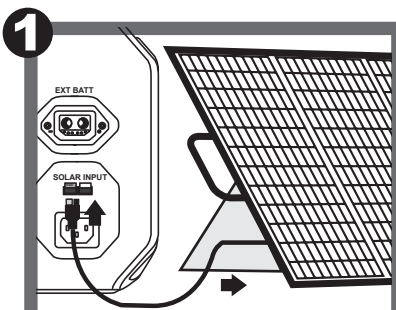

1 Connect your solar panel to the Solar Input in the back of your Battery Generator.

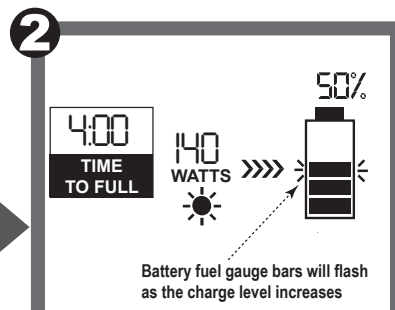

2 The Intelligent LCD Screen will show the solar icon, the input power and the battery charge level. (Press the DISPLAY button to turn off this screen)

Optimizing Your Solar Charging

The estimated charge time is based on a 200W solar panel in ideal/sunny conditions. The amount of power delivered to the battery may be affected by actual conditions and power transfer loss. The Battery Generator is compatible with all standard solar panels. You may also use smaller, lower-wattage solar panels to charge your Battery Generator (charge times will vary according to the wattage of your panel).

To obtain the fastest charge time, position your solar panel where it will receive the maximum exposure to direct sunlight. If the solar panel is placed in shade or is used in cloudy conditions, it may take significantly longer to charge your Battery Generator.

You may also connect additional solar panels (up to 400 Watts of total input power), which reduces the charging time of your Battery Generator and increases the runtime of your connected devices. Please see details below.

Connecting an additional solar panel

Estimated Charge Time: ~4 hours to full (with 2X 200W panels connected)

NOTE: Charge time based on ideal/sunny conditions. The actual charge time and extended run time depends upon the total wattage of your connected solar panels.

NOTE: For optimum solar charging, we recommend connecting two solar panels rated at 200 Watts output per panel.

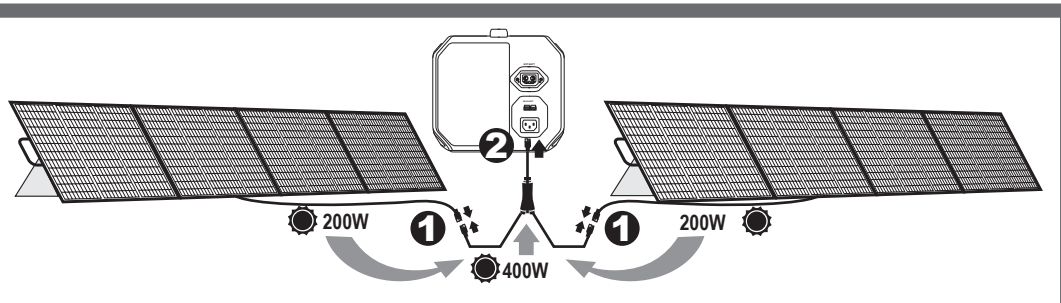

1 Connect each solar panel to the Anderson Powerpole 15/45 combiner cable (sold separately).

2 Connect the combiner cable to the solar input port of your Battery Generator.

NOTE: The combiner cable must be a PARALLEL type. Do not use Series type combiner.

Important Note

Please refer to the specification table for maximum Solar Controller Wattage (varies by model).

Why Add Another Solar Panel?

The Battery Generator has the capability of connecting more than one solar panel, for a total of up to 400W as long as they are of similar voltages and connected in PARALLEL.

Adding another solar panel to help provide power to your Battery Generator has significant advantages:

- Faster Charging:** The Battery Generator charges up to twice as quickly when utilizing the combined power of two panels.
- Longer Runtimes:** While your Battery Generator is charging from both solar panels, the greater input power helps to offset the total battery draw of the items plugged into the Battery Generator. When there is more power coming in to the Battery Generator than going out, your devices can run for longer.

*Additional solar panel and combiner cable sold separately.

Additional Features

Using your Battery Generator as a stand-alone portable power pack

! Each output type (USB, AC, DC) has a separate power button with an indicator light to show that it is on. When any port is on, the intelligent LCD screen will also turn on. You can turn off the intelligent LCD screen at any time by pressing the DISPLAY button below the screen.

1

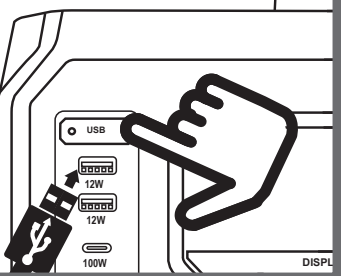

Plug your item(s) into the Battery Generator and press the button to activate the outlets. (Example shown: USB ports)

2

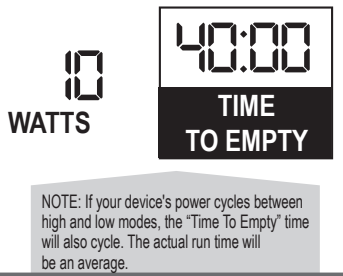

The Intelligent LCD Screen will show output power and "Time To Empty".

Connecting Multiple Items

You can power and charge several items at once using any combination of available AC/12V outlets and USB ports, as long as the total combined power draw of all connected items does not exceed the rated Output Power.

Please note: The more items that are connected, the faster your Battery Generator will consume its available battery power and needs to be recharged.

Conserving Battery Power

When you are done using the outlet(s) and USB port(s), press the button again to turn them off. This will keep the internal battery from passively draining.

Additionally, when an output is not used for more than five hours it will automatically turn off to conserve battery power. To bypass this feature, please see "Power-Save Off" section on next page.

Using your Battery Generator as an Uninterrupted Power Supply

! Your Battery Generator can serve as an Uninterrupted Power Supply (UPS) to provide reliable backup power during outages. If the Battery Generator is connected to AC power and turned ON, when an outage is detected, internal sensors automatically activate the Battery Generator to power any electronics that are plugged into its output ports. This is a valuable way to keep refrigerators, televisions, Wi-Fi routers and other critical household devices and appliances working when you need them the most. (For a list of suggested compatible items and approximate run times, see "Household Items: Approximate Run Times").

1

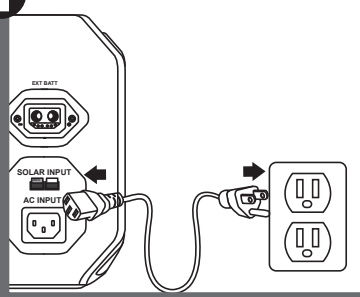

Plug the AC charging cord into the AC Input on the back of the Battery Generator. Plug the other end of the cord into an AC outlet.

2

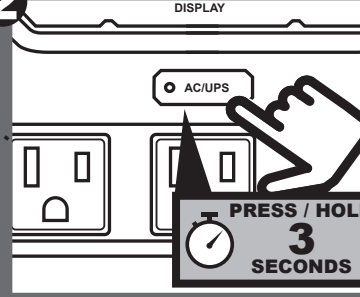

Press the AC/UPS button located near the output. Hold for three (3) seconds. While in UPS mode, the output LED will flash.

3

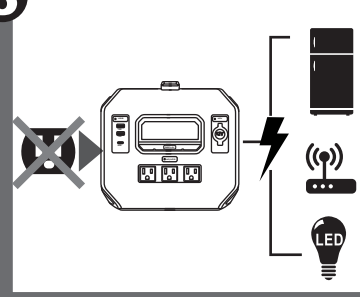

When an outage occurs, the Battery Generator automatically supplies power to your connected items. See "Household Items: Approximate Run Times".

Automatic Recharging

Keep the Battery Generator plugged into an AC outlet, even while you are currently experiencing a power outage. Once power has been restored, your Battery Generator will automatically begin recharging and will stop charging when full — no user action required.

Conserving Power

The lower the wattage of your electronics, the longer the Battery Generator will be able to power them. If you must connect a larger-wattage device (such as a refrigerator or sump pump), you may wish to connect ONLY that item to maximize your battery time.

Using the Extension Pack to supply extra battery runtime

What is the Extension Pack? (sold separately)



The Extension Pack is an external battery pack which provides extended run time for your Battery Generator. When you need more battery capacity, simply connect the Extension Pack.

Additional Features (cont'd)

Connecting And Charging Your Extension Pack (sold separately)

The Extension Pack Power Cord that is included with your Extension Pack creates a two-way power connection, allowing the Extension Pack to supply backup battery power to the Battery Generator, and also allows the Battery Generator to recharge the Extension Pack.

⚠ IMPORTANT: Please use ONLY the included Extension Pack Power Cord to connect your Battery Generator and Extension Pack. Using another power cord may cause personal injury or cause damage to your Battery Generator, Extension Pack, damage any connected items, and void your warranty.

⚠ IMPORTANT: Please make sure the connector ends of your Power Cord are free of dust, dirt, moisture and debris to avoid shorting out the Battery Generator and/or Extension Pack before connecting. Please store your Power Cord in a clean, dry place when is not in use to keep it free from contamination.

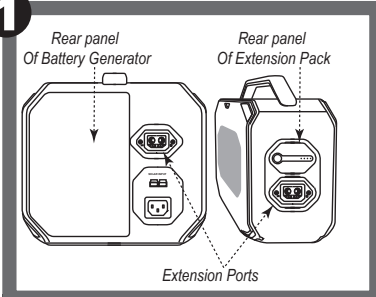
- 

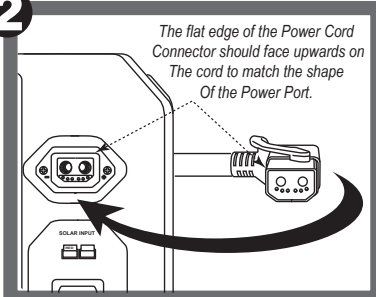
Place the Battery Generator next to the Extension Pack on a clean, dry flat surface. The rear panels of the Battery Generator and the Extension Pack should face towards you.
- 

The flat edge of the Power Cord Connector should face upwards on the cord to match the shape of the Power Port.

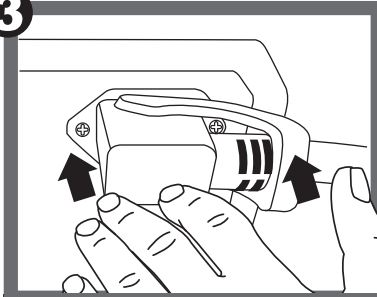
Connect the matching end of the power cord to the port on the generator, making sure the cord and port are properly aligned.
- 

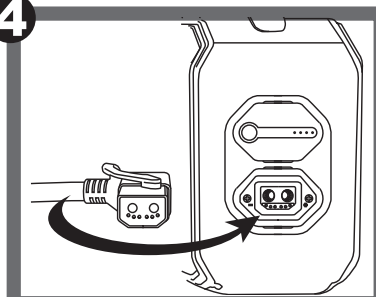
Press firmly on the Power Cord to ensure a secure connection with the Extension Port of the Battery Generator.
- 

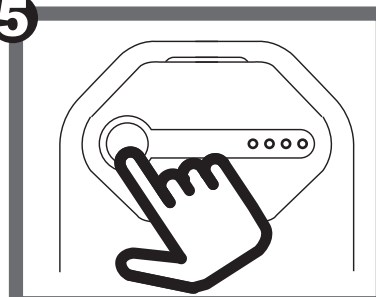
Repeat Steps 2-3 above to connect the other end of the Power Cord to the Extension Pack.
- 

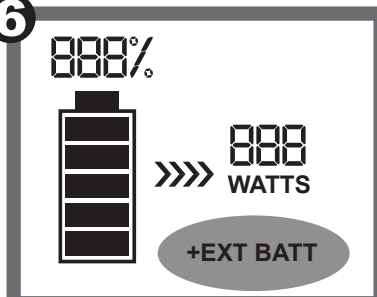
Press fuel gauge button to check battery level or charge status.
- 

You will see the "EXT BATT" icon on the Battery Generator's Intelligent LCD Screen; the fuel gauge now displays the combined battery level of both units.

Charging Your Extension Pack

⚠ The Extension Pack cannot be charged separately; it is designed to connect to the Battery Generator unit to charge and recharge.

⚠ IMPORTANT: Please ensure that the Battery Generator is connected to either AC or solar power while it is charging the Extension Pack to avoid depleting the Battery Generator's own battery.

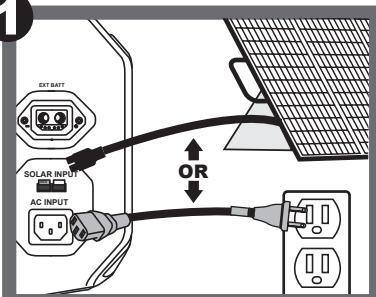
- 

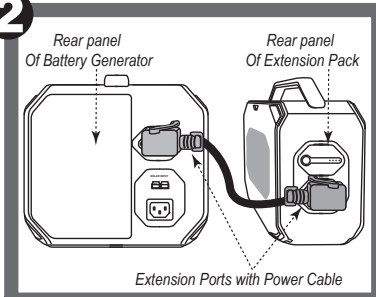
Plug the Battery Generator into AC and / or solar power.
- 

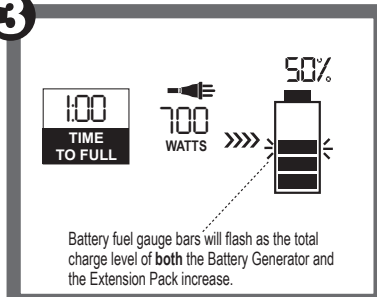
Connect your Power Cable to the Battery Generator and the Extension Pack. Both units will now begin charging together.
- 

Battery fuel gauge bars will flash as the total charge level of both the Battery Generator and the Extension Pack increase.

The fuel gauge will flash as both units charge. The fuel gauge now displays the combined battery level of both units.

Additional Features (cont'd)

Disconnecting Your Extension Pack

1

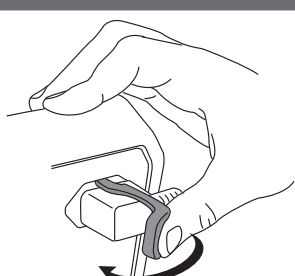

Pull the release lever to unlock the Power Cord.

2

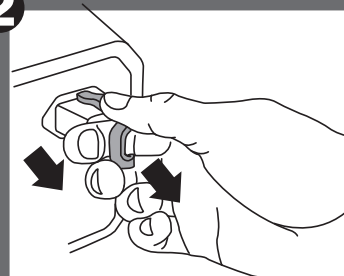

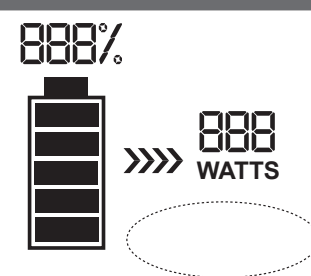

Steady the Battery Generator with one hand so it does not move. With your other hand, use the Release Lever as a finger loop.

3



The "+EXT BATT" icon will no longer show on the Battery Generator's Intelligent LCD Screen. Repeat Steps 1 and 2 to disconnect the Extension Pack. Store the Power Cord in a clean and dry place.

Power-Save Off Mode

-  To conserve power, each output is designed to automatically turn off if there is less than 10W-AC or 100mA-USB/12V power output for more than five hours. However, you can over-ride this power save feature by simply pressing and holding the corresponding On/Off button (AC/USB/12V) for 3 seconds.
-  **IMPORTANT:** Overriding the Power Save mode for long periods of time may deplete your Battery Generator's battery. Please monitor your available charge using the Fuel Gauge and Time To Empty indicators on the Intelligent LCD Screen and recharge your Battery Generator regularly as required.



USE THIS MODE FOR CPAP AND OTHER LOW-DRAW APPLIANCES

Why use Power Save Off Mode?

Your Battery Generator is equipped with an automatic shutdown (Power Save) feature which protects the internal battery from being passively drained. It automatically shuts down after 5 hours if the power draw is below 10 Watts on the AC outlet or 100 mA on the USB ports. Some devices, such as CPAP machines, draw a very small amount of power for an extended time, and can shut down when the Battery Generator goes into its Power Save mode.

Power Save Off mode bypasses the automatic shutdown feature and allows your device to function uninterrupted.

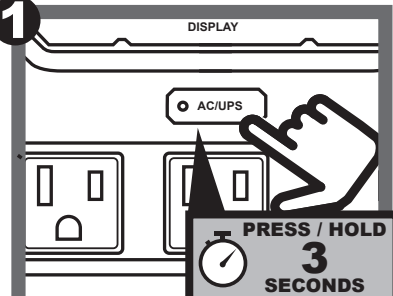
1



Press the AC/UPS button located near the output. Hold for three (3) seconds.

2

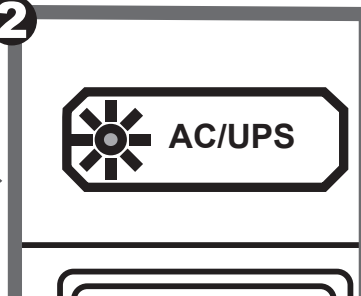

While in Power Save Off mode, the output LED will flash.

3

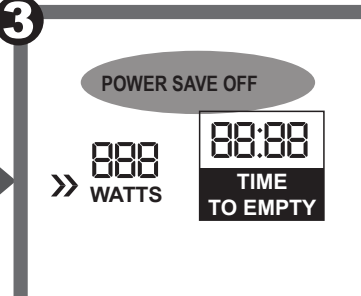

You will also see the "POWER SAVE OFF" message on the LCD screen.

4

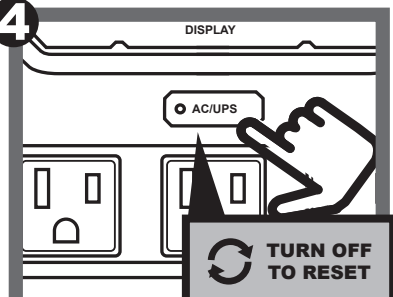

Press the AC/UPS button again to turn the output OFF and reset the port to its default power save mode.

5

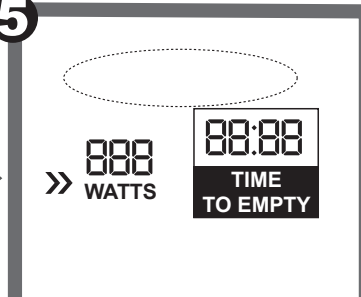

The "POWER SAVE OFF" will no longer show on the Battery Generator's Intelligent LCD Screen.

Important Note:

Once the Power Save Off mode is activated, it is possible to completely deplete the Battery Generator's internal battery with a constant passive power draw.

Please disconnect any low-draw devices when they are not in use to conserve battery power. Please check the Fuel Gauge and Time to Empty indicators on the LCD screen regularly, and recharge your Battery Generator often to make sure that you will always have the power to run your most critical household items.

Reference

Household Items: Approximate Run Times

Device	Continuous draw (Watts)	750	1000	1500
LED string lights	3.3W	225 hours	280 hours	450 hours
LED light bulb (100 W Equivalent)	14W	52 hours	60 hours	105 hours
LED Light bulb (60 W Equivalent)	8W	60 hours	100 hours	120 hours
Incandescent light bulb	59W	12 hours	14 hours	25 hours
CPAP	53W	23 hours	32 hours	47 hours
TV (42" LED)	48W	16 hours	16 hours	33 hours
Cable modem + Wi-Fi router	13W	45 hours	60 hours	90 hours
Table fan	53W	12 hours	17 hours	25 hours
Bar fridge (1.7 cu ft)	~50W	12 hours	16 hours	24 hours
Dorm fridge/Mini fridge (3.7 cu ft)	~40W	15 hours	20 hours	30 hours
Full size refrigerator (18 cu ft)	78W	13 hours	18 hours	27 hours
Large size refrigerator (28 cu ft)	134W	--	6 hours	8 hours
Ice maker	90W	7 hours	9 hours	14 hours
Coffee maker	900W	--	5 pots	7 pots
Blender	212W	3 hours	3.5 hours	6 hours
Electric hot plate (single)	852W	--	1.2 hours	1.6 hours
Sump pump (1/4HP)	250W	2 hours	3 hours	4.5 hours
Laptop	51Wh Battery	10 charges	14 charges	21 charges
Smartphone	11Wh Battery	50 charges	70 charges	105 charges

Important Note:

The power draw and run times of these household items are examples only and actual results may vary.

Important Note:

High power draw devices such as air conditioners, space heaters, rice cookers, hot plates, circular saws, and large sump pumps (over 1/4 hp) may result in shorter run times. Refer to the Specification Table for output power ratings.

Product Specifications

Model	750	1000	1500
Battery			
Chemistry	Lithium-Ion		
Capacity (Max)	743Wh	991Wh	1487Wh
Input			
AC Charger	120V AC, 60Hz, 520W / 1100W Max (Bypass)	120V AC, 60Hz, 700W / 1300W Max (Bypass)	
Solar Controller	MPPT 13-30V, 200W Max	MPPT 13-30V, 400W Max	
AC Outlet			
AC Output Voltage	120V AC, 60Hz total 700W, Pure Sine Wave	120V AC, 60Hz total 1200W, Pure Sine Wave	
Number of outlets	3		
AC Output Power (Continuous)	700W	1200W	
AC Output Power (60 Seconds)	700-910W	1200-1500W	
AC Output Power (3 Seconds)	910-1400W	1500-2400W	
UPS Function			
UPS function	Yes		
UPS switching time	<10 ms		
12V CLA Port			
Power Output	12-13.5V DC=10A Max		

Model	750	1000	1500
USB Ports			
USB - A (2x)	5V-2.4A per port (2 ports total 4.8A)		
USB - C PD (1x, output only)	5V-3A / 9V-3A / 12V-3A / 15V-3A / 20V-3A, 60W Max	5V-3A / 9V-3A / 12V-3A / 15V-3A / 20V-5A, 100W Max	
Operating Temperatures			
Charging	0° - 45° C / 32° - 113° F		
Discharging (in use)	-10° - 45° C / 14° - 113° F		
Certifications			
Safety	ANSI/CAN/UL2743/UL1778		
Efficiency	CEC/NRcan/DOE		
EMI	FCC Part 15		
Dimensions and Weight			
Dimensions (LxWxH)	39.0 x 22.4 x 24.2 cm / 15.4 x 8.8 x 9.5 in		
Weight (kg/lb)	8.8 kg / 19.4 lb	11.0 kg / 24.3 lb	12.9 kg / 28.4 lb

Maintenance

In order to keep your Battery Generator Power Station operating efficiently, periodically clean and maintain your unit using the simple steps below.

- Clean the surface of the Battery Generator when necessary. Always use a soft sponge or cloth for cleaning. A mild, non-abrasive cleaning detergent may be used to remove stubborn dirt.
- Avoid using your Battery Generator in dirty conditions where foreign matter such as dust, dirt and moisture can clog the AC and USB outlets and charging ports. Keep the Battery Generator in a well-ventilated area away from direct exposure to outside elements whenever possible.
- Do not attempt to insert anything into the Battery Generator's openings to clean them, as this may result in injury or damage to the Battery Generator and void the warranty.
- Do not attempt to repair the Battery Generator yourself, as this may result in injury or damage to the Battery Generator and void the warranty.

Troubleshooting Guide

Your Battery Generator features several built-in protection features to ensure safe and efficient operation. Below is a guide which shows the typical faults that occur during normal operation and how to correct them and resume use. If a fault occurs, the following warning(s) will appear on the intelligent LCD screen. Please refer to the table below to safely correct any problems and allow your Battery Generator to reset and resume operation. If you have additional questions, please contact Customer Service at 888-617-5884.

Fault Type	What it means	What to do
HI TEMP / LO TEMP	Your Battery Generator is too hot or too cold (operating temperature range is -10° to 45° C / 14° to 113° F)	Move the Battery Generator to a cooler or warmer location as needed
OUTPUT OVERLOAD	Excessive power draw	Remove some of the connected items to lower the total draw on the Battery Generator, then turn it on again.
LOW BATTERY	Low battery voltage (<9V)	Charge the Battery Generator
Flashing  icon	Solar Input range exceeded (See Product Specifications)	Check solar panel configuration
Shuts down after 5 hours	Shuts down to save battery charge when it detects low power need	Press and hold power button to go into Power Safe Off mode, LED flashes in this mode. NOTE: Turning port off cancels the Power Save Off mode.
Unit is not charging	The Input Overload Switch may have tripped due to a fault in the AC input source	Check AC input source to make sure there are no short circuits, then push in the red input overload switch to reset it, and turn it back on.

Safety Information





This section contains important safety information. Before using the product, READ ALL instructions and cautionary markings on or provided with the product, and all appropriate sections of this guide. The product contains no user-serviceable parts. SAVE THESE INSTRUCTIONS.

IMPORTANT SAFETY INSTRUCTIONS - SAVE THESE INSTRUCTIONS

-  **WARNING – When using this product, basic precautions should always be followed, including the following:**
- Read all the instructions before using the product.
 - To reduce the risk of injury, close supervision is necessary when the product is used near children.
 - Do not put fingers or hands into the product.
 - Do not expose Battery Generator to rain or snow.
 - Use of an attachment not recommended or sold by Battery Generator manufacturer may result in a risk of fire, electric shock, or injury to persons.
 - To reduce risk of damage to the electric plug and cord, pull the plug rather than the cord when disconnecting the Battery Generator.
 - Do not use the Battery Generator or appliance that is damaged or modified. A damaged or modified Battery Generator may exhibit unpredictable behavior resulting in fire, explosion or risk of injury.
 - Do not operate the Battery Generator with a damaged cord or plug, or a damaged output cable.
 - Do not disassemble the Battery Generator, take it to a qualified service person when service or repair is required. Incorrect reassembly may result in a risk of fire or electric shock.
 - To reduce the risk of electric shock, unplug the Battery Generator from the outlet before attempting any instructed servicing.

PERSONAL PRECAUTIONS

- When charging the internal battery, work in a well ventilated area and do not restrict ventilation in any way.
- Do not expose a Battery Generator to fire or excessive temperature. Exposure to fire or temperature above 130°C / 266°F may cause explosion.

-  **WARNING: NO USER SERVICEABLE PARTS**
- There are no user serviceable parts in this unit, DO NOT attempt to open the Battery Generator; this is dangerous and will void the warranty.
-  **WARNING: HEAT GENERATION DURING CHARGING AND USE**
- Charging and discharging generates heat and requires proper air flow. Use in a ventilated area and ensure adequate clearance for the ventilation grills. Blocking the grills may cause overheating and damage to the unit.
-  **WARNING: RISK OF ELECTRIC SHOCK INJURY**
- Do not operate or store in moist conditions to avoid electric shock.
 - If the unit gets wet wait for it to dry completely before using it.
 - Do not insert foreign objects into any of the ports or openings.
-  **WARNING: RISK OF ELECTRIC SHOCK OR FIRE HAZARD**
- Review the specifications of the Battery Generator ports and all connected devices you intend to use.
 - The output ports can generate dangerous voltages.
 - Do not use the Battery Generator if it is damaged or any of the input or output cords are damaged.

FCC / ISED Information

This device complies with part 15 of FCC Rules. Operation is subject to the following two conditions: (1) This device may not cause harmful interference, and (2) this device must accept any interference received, including interference that may cause undesired operation.

Changes or modifications not expressly approved by the party responsible for compliance could void the user's authority to operate the equipment.

NOTE: This equipment has been tested and found to comply with the limits for a Class B digital device, pursuant to part 15 of the FCC Rules. These limits are designed to provide reasonable protection against harmful interference in a residential installation. This equipment generates, uses and can radiate radio frequency energy and, if not installed and used in accordance with the instructions, may cause harmful interference to radio communications. However, there is no guarantee that interference will not occur in a particular installation. If this equipment does cause harmful interference to radio or television reception, which can be determined by turning the equipment off and on, the user is encouraged to try to correct the interference by one or more of the following measures:

- Reorient or relocate the receiving antenna.
- Increase the separation between the equipment and the receiver.
- Connect the equipment into an outlet on a circuit different from that to which the receiver is connected.
- Consult the dealer or an experienced radio/TV technician for help.

CAN ICES-003 (B) / NMB-003 (B)

Support And Warranty

Contacting Customer Support

If you experience any problems or have any questions regarding your product, free technical support is available. Call from a phone where you have access to your product.

Be prepared to provide the following information:

- Name, address and telephone number
- Name of the product
- Make and model of any items or devices that you are using with the product
- Symptoms of the problem(s) and what led to them

Technical Support is available by telephone: **888-617-5884**
or by email at Info@Battery-Biz.com

Written inquires should be directed to:
Battery-Biz Inc.;
Coleman Product Inquiry
1380 Flynn Road, Camarillo, CA 93012, USA

Recycling Information

Battery-Biz is committed to environmental responsibility and recommends that electronic devices be disposed of properly. Please contact your local city offices for information on recycling and disposal programs for e-waste.

For instructions on how to recycle this product visit <http://www.call2recycle.org>.

Two Year Limited Warranty

This product (Product) is warranted (Limited Warranty) by Battery-Biz Inc. (Distributor) against defects in material and workmanship under normal use and service to the original purchaser (Purchaser) for a period of 2 (two) years (Warranty Period) from the original date of purchase. The Limited Warranty does not extend to any subsequent owner or other transferee of the Product. Purchaser shall retain the dated sales receipt as evidence of proof and date of purchase as it will be required for any warranty claim or service. In order to keep the Limited Warranty in effect, the Product must have been handled and used as described in the instructions accompanying this Limited Warranty. The Limited Warranty does not cover any damage due to accident, improper storage, improper installation, modifications, unauthorized repair, normal wear and tear, failure to observe product specifications or safety warnings, force majeure, misuse, abuse or negligence. This Limited Warranty shall be null and void if Product's label(s) have been defaced, altered, or removed.

Remedies Under Warranty

With respect to a defective Product during the Warranty Period, Distributor in its sole and absolute discretion, will either: (a) repair or replace such Product (or the defective part) free of charge or (b) refund the purchase price of such Product. Distributor will pay for shipping and handling fees to return the repaired or replacement product to the Purchaser during the Warranty Period.

Disclaimer Of Warranty

The Limited Warranty described herein is Purchaser's sole remedy. To the extent permitted by law, Distributor disclaims all other implied or express warranties on Product including all warranties of merchantability and/or fitness for any particular purpose.

Limitation Of Liability

Except to the extent of repairing or replacing Product as expressly stated in the Limited Warranty described herein, Distributor shall not be liable for any damages, whether direct, indirect, incidental, special, consequential, exemplary, or otherwise, including lost revenues, lost profits, loss of use of software, loss or recovery of data, rental of replacement equipment, downtime, damage to property, and third-party claims, arising out of any theory of recovery, including statutory, contract or tort. Notwithstanding the terms of any limited or implied warranty or in the event that the Limited Warranty fails in its essential purpose, in no event will Distributor's entire liability exceed the purchase price of the Product. Some states and provinces do not allow the exclusion or limitation of incidental or consequential damages so the above limitations or exclusions and as a result may not apply to Purchaser. This Limited Warranty gives Purchaser specific legal rights. Purchaser may have other rights which vary from state to state and province to province.

In order to be considered for coverage under this Limited Warranty, all warranty returns of Product to Distributor must include (1) a copy of the original receipt for the purchase of Product, (2) a letter from Purchaser referencing the Return Merchandise Authorization number issued by Distributor to Purchaser with a description of the problem, and (3) Purchaser's contact information including phone number and shipping address. Purchaser is responsible for the cost of the warranty return shipping and handling as well as any related claims that may arise.

Product Registration

For complete warranty coverage, please register your Coleman product within fourteen days of purchase.

Visit ColemanPowerStations.com/Register

or scan the QR code to register.

