



Model	Voltage	Hz	HP	kW	SCFM	Pressure		Vacuum		Noise Level	Net Weight	
						mbar	"H2O	mbar	"H2O		kg	lbs
RBH9-15-3	3	60	15	11	850	190	76	190	76	81 db(A)	100	221
		50	10	700	202	81	209	80	76 db(A)	100	221	
RBH9-20-3	3	60	20	15	850	294	118	294	118	81 db(A)	112	247
		50	13	700	300	120	300	120	76 db(A)	112	247	
RBH9-30-3	3	60	30	22	850	430	173	375	151	81 db(A)	159	351
		50	20	700	445	179	350	141	76 db(A)	159	351	

*Refer to curves below for detailed performance data. Performance data and product specifications are subject to change without prior notice. Actual performance may vary by ±10%.

STANDARD FEATURES

- Housing - Aluminum
- Impeller - Aluminum, dynamically balanced
- Direct drive impeller
- Shock absorbing mounting base
- Quiet operation - below OSHA limits
- Inlet & outlet silencers included
- Motor shaft seal standard
- IP 54 TEFC 2 pole squirrel cage ac motor
- 40 Deg C ambient
- Class H insulation 1.15 service factor
- Performance tested ANSI/AMCA210-85
- Voltage
 - 1 = 1/60/50/115/230
 - 2 = 1/60/50/230
 - 3 = 3/60/208-230/460 3/50/220/380

3/60/208-230/460 & 3/50/220/380

RBH9-15-3 replaces HB-919
 RBH9-20-3 replaces HB-929
 RBH9-30-3 replaced HB-939

REQUIRED ACCESSORIES

Note: To obtain warranty coverage relief valve and filter are required.

Pressure Relief Valve RV-02
 Pressure Relief Valve RVA-02

Vacuum Relief Valve RV-02
 Vacuum Relief Valve RVA-02

Pressure Intake Air Filter F245P-400
 Vacuum Air Filter CSL-335P-400



Registered and approved by one or more of these standards agency



TECHNICAL DATA

- [Available online www.all-star-usa.com]
- Performance Temperature Rise Curves
 - AutoCad files
 - Parts List
 - Full load amperage

PRESSURE DATA CURVES ±10%

[See reverse side for Vacuum Curves]

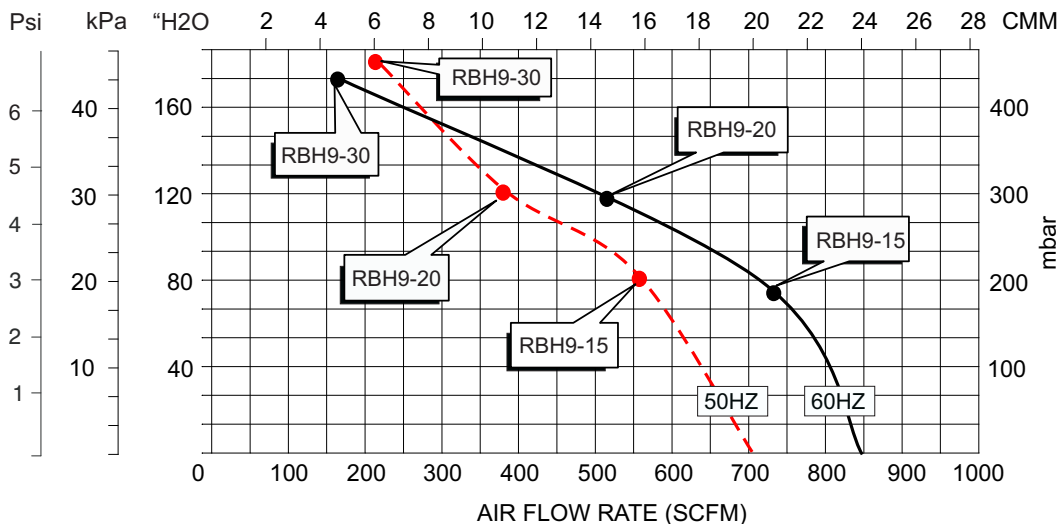

RB9-15-3 / RBH9-15-3
 RB9-20-3 / RBH9-20-3
 RB9-30-3 / RBH9-30-3

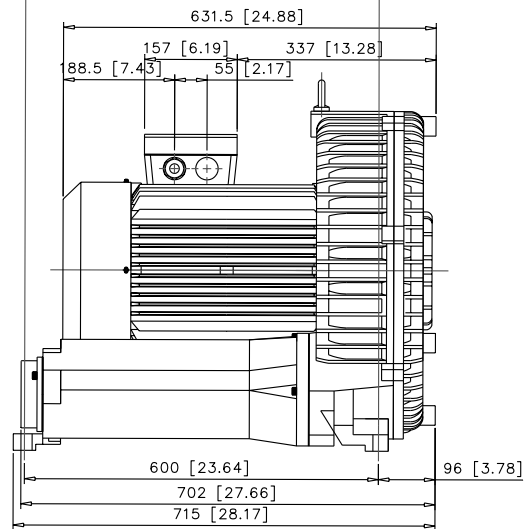
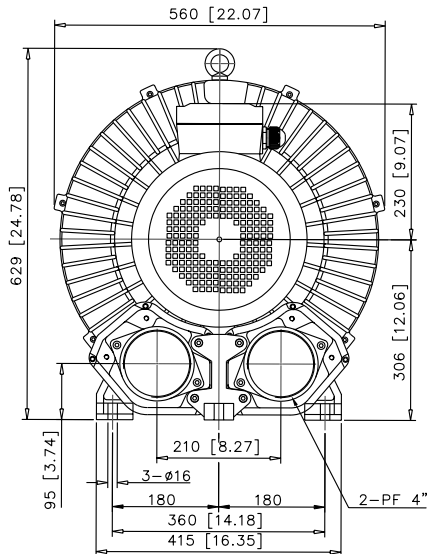
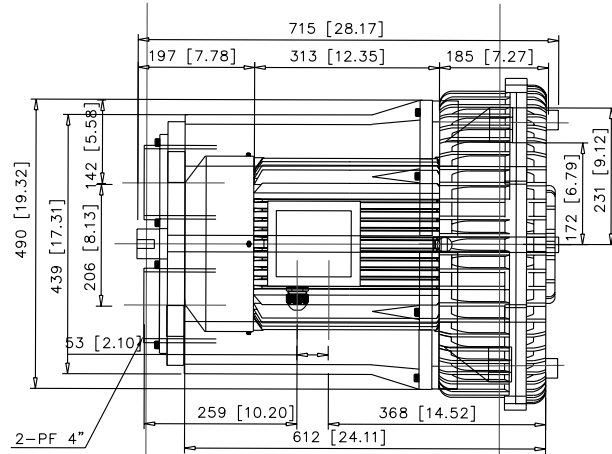
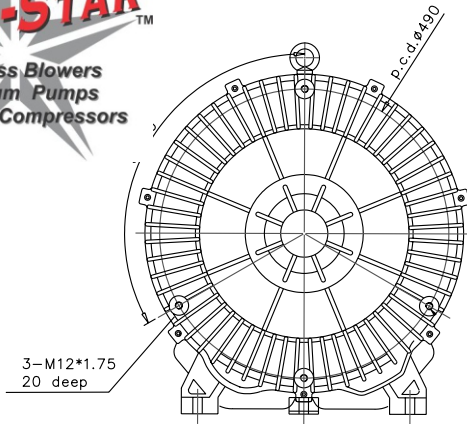

VACUUM DATA CURVE

