

Northeast Isometric

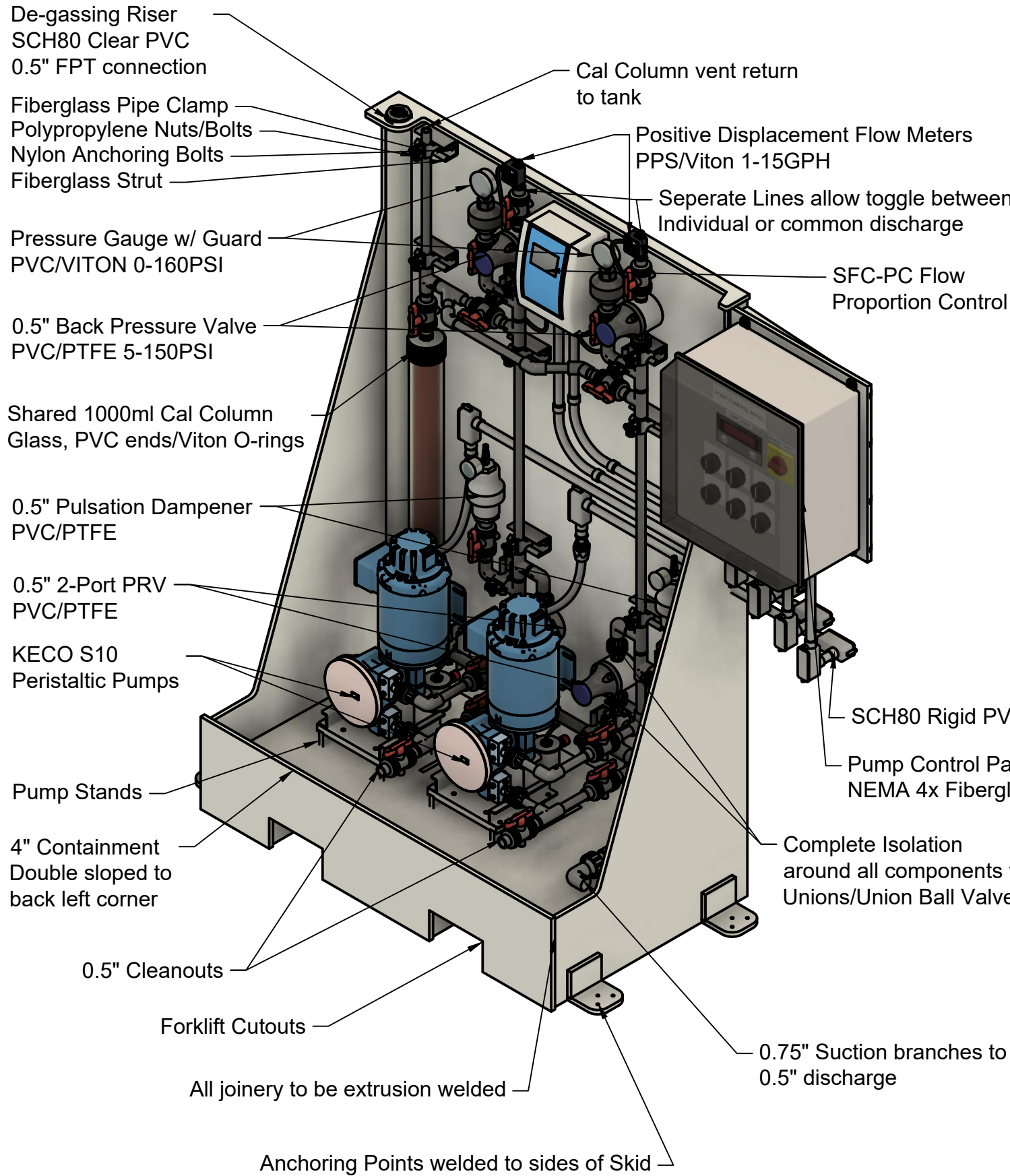

Front

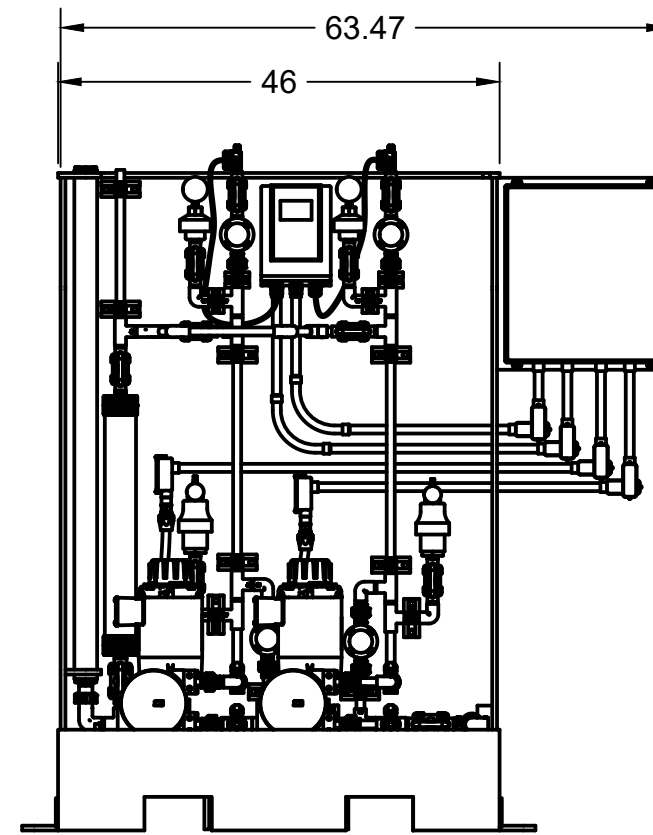

Left

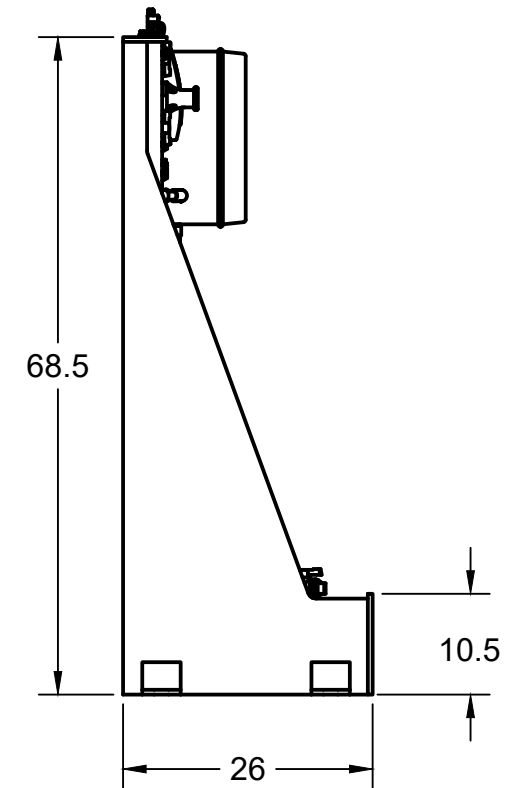

SCH80 Rigid PVC Conduit

Pump Control Panel with
NEMA 4x Fiberglass Enclosure

Skid Material: 0.5" White HDPE (Marine Grade)
Pipe Material: 0.75", 0.5" SCH80 PVC
O-Ring Material: Viton (FKM)
Gasket Material: PTFE (Teflon), Viton (FKM)

		PROJECT		
		TITLE NaOCl Duplex System		
APPROVED	SIZE	CODE	DWG NO	REV
CHECKED	B		0618-1	01
DRAWN	Eric Brillant	7/12/2018	SCALE 1:12	WEIGHT
			SHEET	1/1