

4

3

2

1

NE Isometric

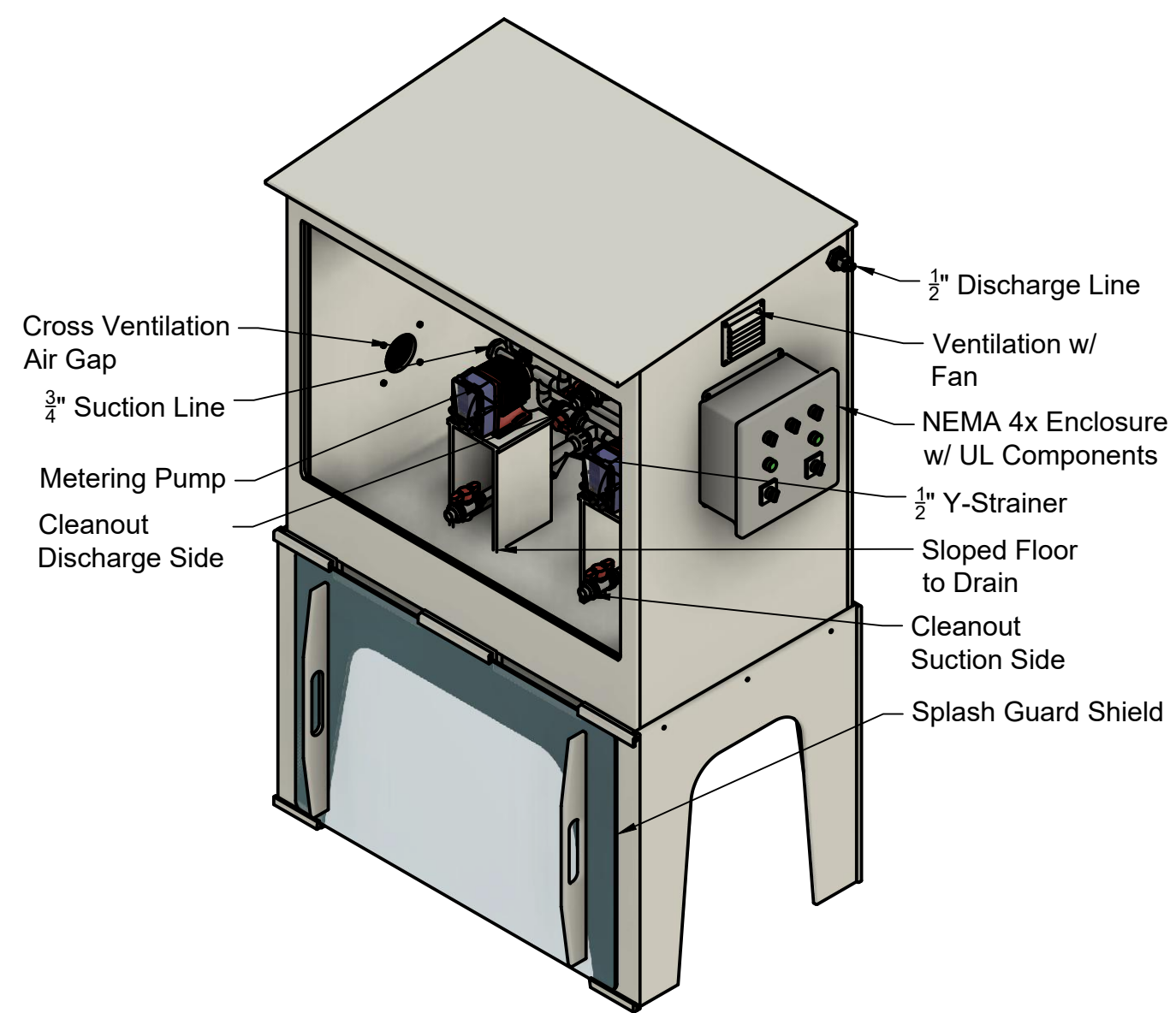

Top

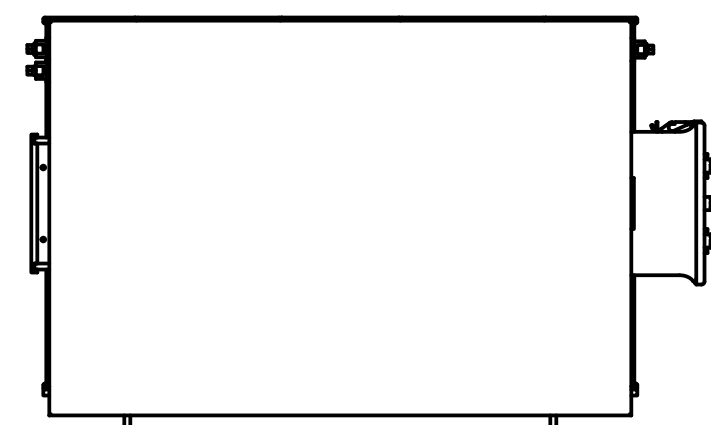

Front

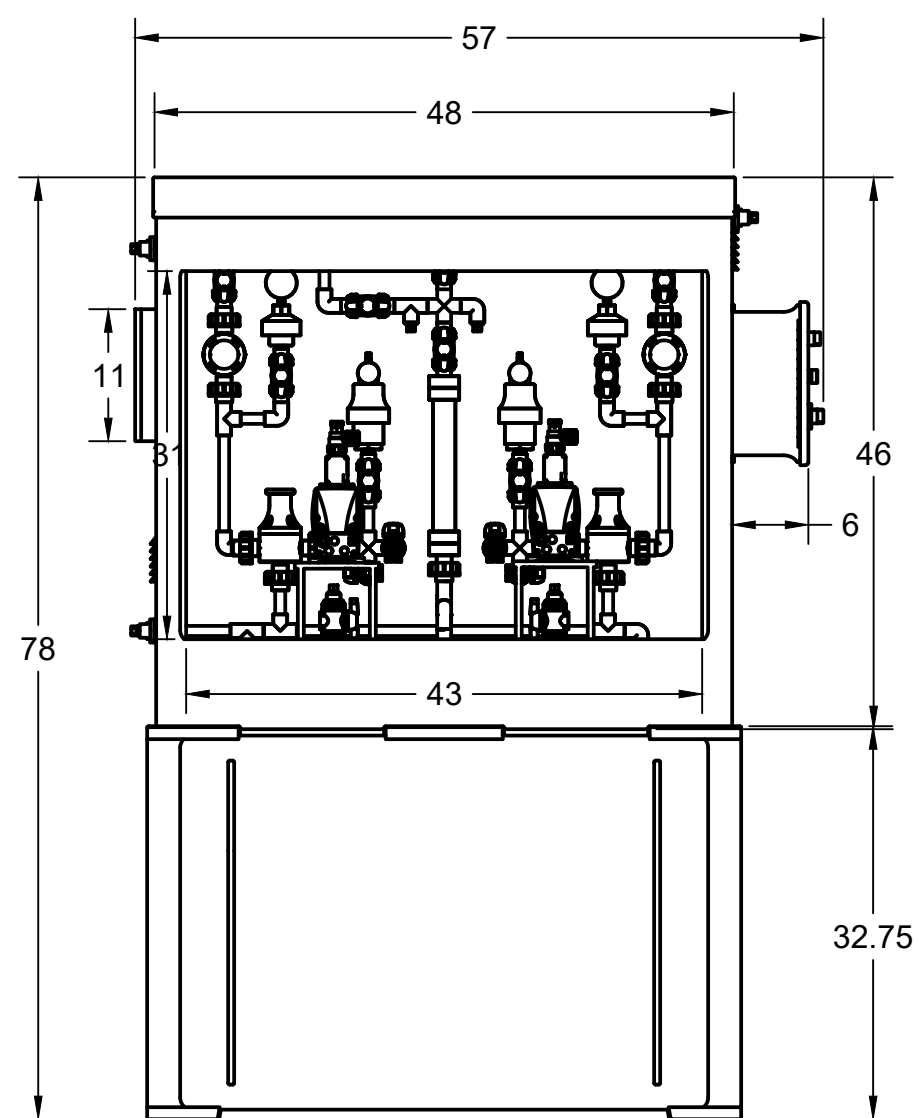

Right Side

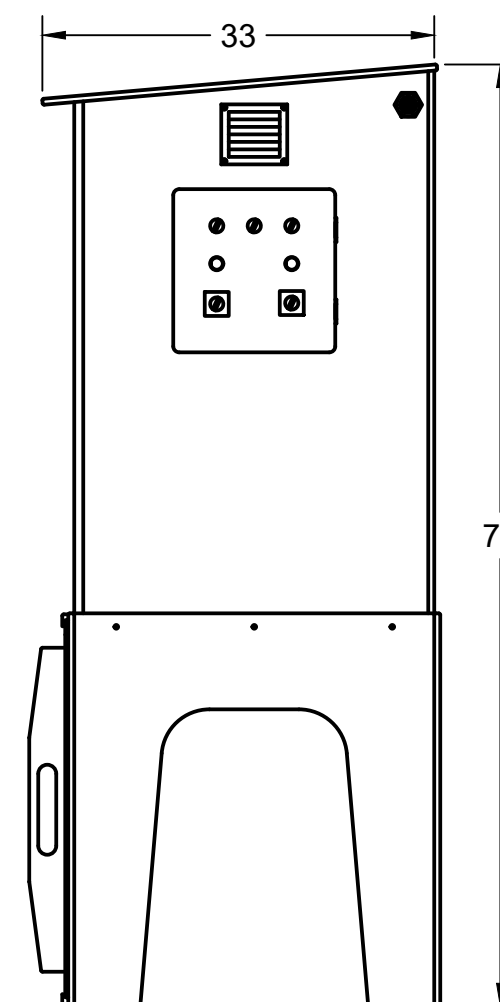

Front

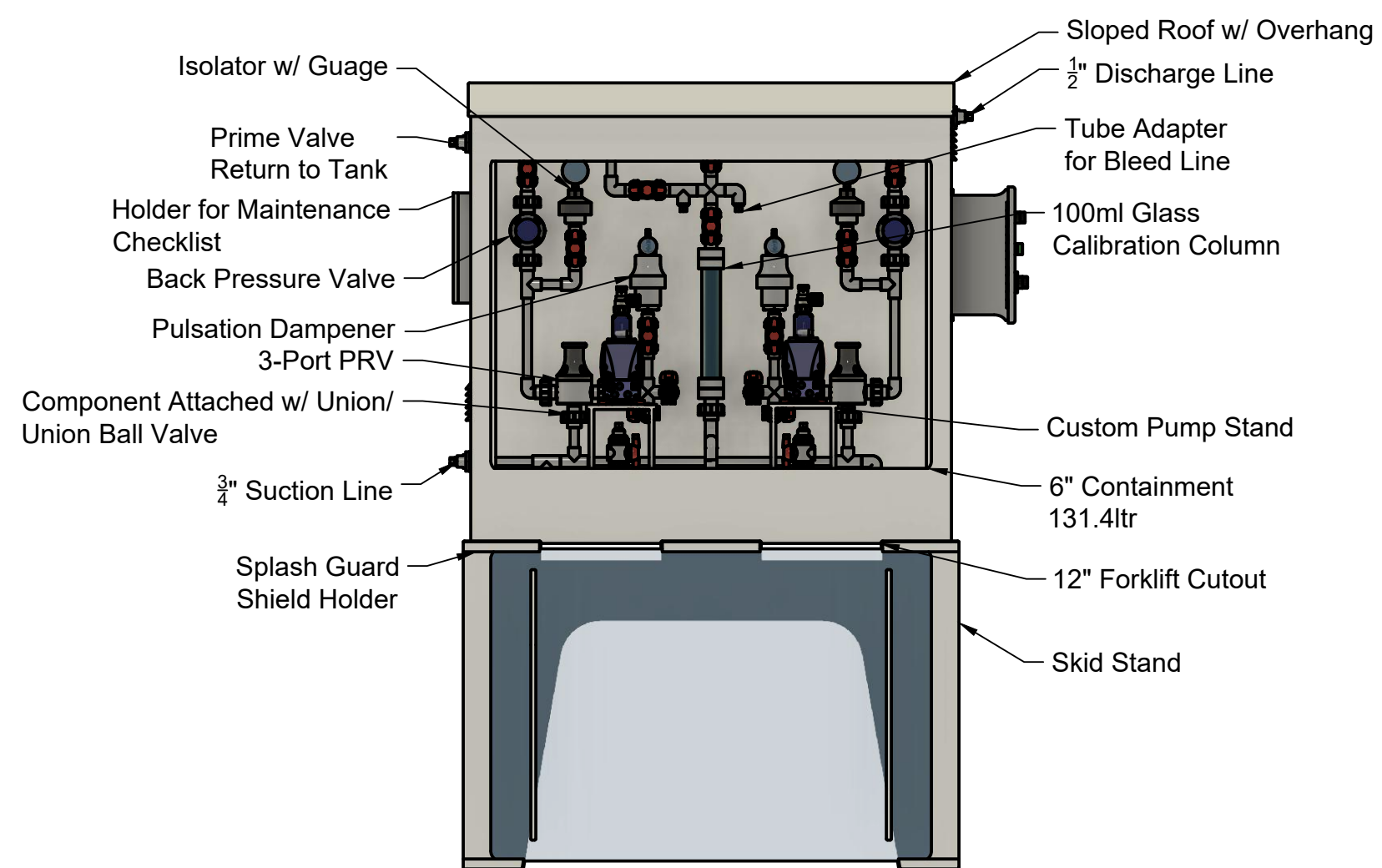

PROJECT
Full Enclosure System

TITLE
Full System Assembly

| | | | | |
|----------------------------|------------|--------|-----------|-----|
| APPROVED | SIZE | CODE | DWG NO | REV |
| CHECKED | C | | | |
| DRAWN Adam Craig 9/13/2018 | SCALE 1:16 | WEIGHT | SHEET 1/1 | |

4

3

2

1

D

D

C

C

B

B

A

A