

OWNER'S MANUAL



MANUAL OPERATED LEVER HOIST ALH SERIES



Capacity
1 Ton through 9 Ton

Atlas Rigging & Lifting, LLC
Reno, NV, USA
Ph: 1-833-ALR-LIFT
www.alrlift.com

Effective: January 1st, 2020

WARRANTY INFORMATION AND TECHNICAL SERVICE

All products sold by Atlas Rigging & Lifting, LLC. are warranted to be free of defects in material and workmanship from date of shipment by Atlas Rigging & Lifting, LLC. If one of our products needs repair of service, please contact Technical Service at 1-833-ALR-LIFT, 8AM to 5PM Anywhere in the US, Monday through Friday.

Warranty Period and Coverage

- ALR products carry a limited warranty of 2 years.
- Accessories carry a limited warranty of one year from the date of receipt.
- This warranty covers only the initial purchaser of the product from the date of delivery.
- This warranty covers any defects in workmanship or materials subject to the limitations stated below.
- This warranty does not cover failures due directly or indirectly to misuse, abuse, negligence or accidents, normal wear-and-tear, improper repair, alterations or lack of maintenance.

Limitations on This Warranty

The product must be used in accordance to ALR recommendations. The product must not have been subjected to misused, abused, neglected, lack of maintenance, negligence or unauthorized repairs or alterations.

Should any defect in material or workmanship occur during the period stated above, the product will be inspected by ALR and at its discretion, ALR will either replace or repair the hoist in question free of charge and delivery F.O.B. Atlas Rigging & Lifting, LLC. place of business or customer.

Customer must receive a Return Goods Authorization form from ALR or an Authorized ALR service center prior to shipping product for warranty evaluation. An explanation of the product issues must accompany the product. Product must be returned freight pre-paid. Upon repair, the product will be covered for the remainder of the original warranty period. Other restrictions apply. Please contact Technical Service for additional details of warranty restrictions. If it is determined that the product was misused, abused, neglected, used in a negligent manner or was subject to unauthorized repair or modification, the customer will be responsible for the cost of the return of the product.

Atlas Rigging & Lifting Inc. disclaims any and all other warranties of any kind expressed or implied as to the product's merchantability or fitness for a particular application. Atlas Rigging & Lifting Inc. will not be liable for death, injuries to persons or property or for incidental, contingent, special or consequential damages, loss or expense arising in connection with the use or inability whatever, regardless of whether damage, loss or expense results from any act by Atlas Rigging & Lifting Inc., whether negligent or willful, or from any other reason.

Technical Support

Please contact Technical Service at 1-833-ALR-LIFT. **Please note that you will be asked to provide proof of initial purchase when calling.** If a product requires further inspection, the Technical Service representative will explain and assist with any additional action needed.

Table of Contents

Section	Page Number
1.0 Important Information and Warnings	4
1.1 Term and Summary	4
1.2 Warning	4
1.3 Introduction	5
1.4 Warning Tag and Label	6
2.0 Unpacking	7
2.1 Content of Carton	7
3.0 Pre-operation Inspection	7
4.0 Hoist Operation	7
4.1 Free Chain Principle	7
4.2 Lifting and Lowering Operation	7
4.3 Introduction	8
5.0 Care in Use	8
6.0 Maintenance & Inspection	8
6.1 Inspection	9
7.0 Storage of Hoist	10
8.0 Specifications	11
8.1 Stock Number	11
9.0 Installation	12
10.0 Operation	14
11.0 Precautions	15
12.0 Point Hooks	15
13.0 Overload Protection	15
14.0 Inspection and Maintenance	15
15.0 Allowable Limits for Load Chain and Hooks	16
16.0 Hooks (Top and Bottom)	16
17.0 Timing Marks for Gear Replacement	16
18.0 Troubleshooting	17
19.0 Replacement Parts	17

1.0 Important Information and Warnings

Manual Lever Hoist equipment should not be operated or maintained by any person who has not read and understood all the contents of this operator's manual. Failure to read and comply with the content of this manual can result in serious bodily injury or death, and or property damage.

1.1 Term and Summary

This manual provides important information for personnel involved with the installation, operation and maintenance of this product. Although you may be familiar with this or similar equipment, it is strongly recommended that you read this manual before installing, operating, or maintaining the product.

Danger, Warning, Caution, and Notice

Throughout this manual there are steps and procedures that can present hazardous situations. The following signal words are used to identify the degree or level of hazard seriousness.

DANGER Danger indicates an imminently hazardous situation which, if not avoided, **will** result in **death or serious injury**, and property damage.

WARNING Warning indicates an imminently hazardous situation which, if not avoided, **could** result in **death or serious injury**, and property damage.

CAUTION Caution indicates an imminently hazardous situation which, if not avoided, **may** result in **minor or moderate injury**, and property damage.

NOTICE Notice is used to notify people of installation, operation, or maintenance information which is important but not directly hazard-related.

1.2 WARNING !!!

1. **Read and understand** the entire owner's manual before attempting operation. Failure to comply with instructions and warnings may cause serious injury.
2. **Understand and follow** all procedures as set forth in American National Standards titled "Performance Standard for Manually Lever Operated Lever Hoists," ANSI/ASME HST-3; and "Manually Lever Operated Hoists," ANSI/ASME B30.21. These standards are available through the American Society of Mechanical Engineers at www.asme.org.
3. **Do not** use until proper training and knowledge have been obtained. This lever hoist is designed and intended for use by properly trained and experienced personnel only. If you are not familiar with the proper and safe operation of a lever hoist,
4. **Do not** use this lever hoist for other than its intended use. If used for other purposes, ALR disclaims any real or implied warranty and holds itself harmless from any injury that may result from that use.
5. **Do not** use If hoist is damaged. do not use until it has been repaired or replaced. Always inspect the lever hoist for damage prior to use.
6. **Do not** use lever hoist to lift, support or transport people; or to lift or support loads over people.
7. **Do not** load beyond the rated capacity. See ID Plates.
8. **Do not** operate hoist unless load is centered between top and bottom hooks.
9. **Do not** attempt to extend the lever handle using a "cheater pipe" or any other such device.
10. **Do not** strike the lever handle with a hammer or any other object.
11. **Do not** use the chain as a sling. This may cause damage to the chain.
12. **Do not** use more than one lever hoist to lift or move a load. If this is unavoidable, each hoist must have the same capacity as the load to be moved.
13. **Never** allow chain to "set" over sharp edges. All pulls or lifts must be made with straight chain that is free of obstacles.

14. **Do not** use hoist if the chain is twisted, kinked or damaged.
15. **Do not** attempt to lengthen or repair load chain.
16. **Do not** use an extension pipe or cheater bar to apply more pressure to the lever handle.
17. **Do not** use the hoist if either hook is stretched, deformed, or has a broken or missing safety latch. Always replace the safety latch and/or the hook before placing the hoist back in service.
18. **Do not** heat treat and DO not weld any part of the Lever Hoist, especially the load chain.
19. **Do not** leave a load on the Lever Hoist unattended.
20. **Do not** shock load Lever Hoist, chain or hook.
21. **Do not** operate the Lever Hoist unless it is rigged to pull in a straight line from hook to hook, and the frame is allowed to freely swivel on the upper hook.
22. **Do not** wrap the load chain around the load and hook onto itself as a choker chain, or bring the load in contact with the Lever Hoist.
23. **Do not** take up the load chain to the point where the end ring or lower hook becomes jammed against the frame.
24. **Do not** point load the hook – ensure hook is correctly position with the load at the optimum position.
25. **Do not** use spray lubricates in or near brake discs.
26. If the lever handle is difficult to operate, then the load exceeds the capacity of the hoist. Reduce load or select a hoist of larger capacity.
27. On hoists with the overload warning lever, do not use this device to measure load weight.

1.3 Introduction

Congratulations on your ALR Chain Lever Hoist. The ALR Chain Lever Hoist you have chosen is a heavy-duty hoist, designed to retain its operational features under normal operating conditions. This manual contains instructions on installation, safety precautions, general operating procedures, maintenance instructions and parts breakdown. In order to achieve years of satisfactory service from your ALR Chain Lever Hoist a routine of careful operation, regular maintenance and lubrication should be applied as instructed within this ALR manual.

Prior to the operation, installation or maintenance of your ALR Chain Lever Hoist, please read all the contents contained within this manual. At all times only competent and experienced personnel should operate, install or maintain this hoist. Failure to comply with the instructions contained within this manual can result in both physical and/or property damage. In keeping with statutory requirements, and best use for your ALR Chain

We recommended a periodic maintenance check every 12 months via your ALR distributor. ALR's experienced and competent personnel will perform a complete service including preventative maintenance, genuine spares and repairs service.

On completion of installation, but prior to your ALR Chain Lever Hoist being put into regular service, the following procedures should be carried out –

1. Check that all joints and fasteners are tight and secure.
2. Operate the hoist with both no load and full load, and check that the operation is smooth at all times.
3. Check operation of hoist brake, under light load and full load conditions.
4. Traveling units - run throughout the full extent of the runway, ensuring adequate clearance at all times.
5. Please ensure your ALR Test Cert has been stored and the unit(s) have been placed in your lifting register for future reference.

1.4 Warning Tag and Label

The warning label & tag illustrated below in Figure 1 & 2 are supplied with each hoist shipped from factory. Read and obey all warning attached to this hoist. Tag and label are not shown actual size.

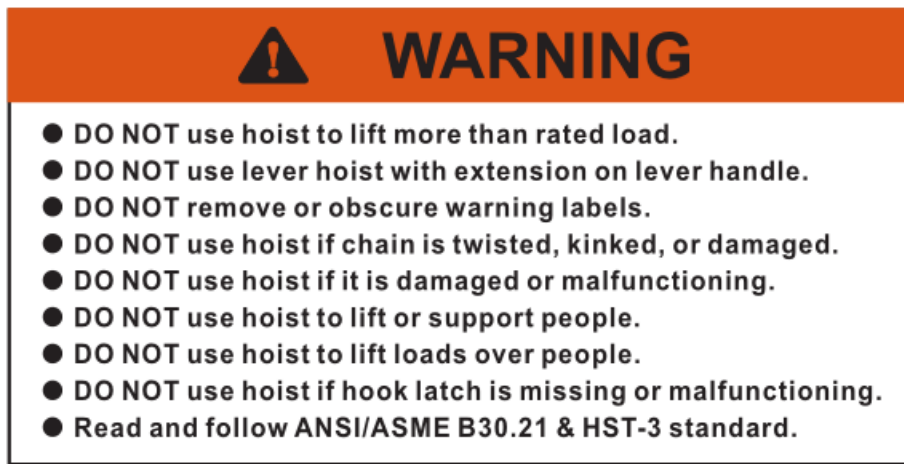

Figure 1 Warning Label on lever hoist's gear cover (shown larger for legibility)



Figure 2 Warning Tag to the end of load chain

2.0 UNPACKING

Open carton and check for shipping damage. Report any damage immediately to your distributor and shipping agent. Do not discard any shipping material until the Lever Hoist is assembled and running properly. Read this entire instruction manual thoroughly for set-up, maintenance and safety instructions.

2.1 CONTENT OF CARTON

- 1 Lever Operated Lever Hoist
- 1 Owner's Manual
- 1 Test certificate

3.0 PRE-OPERATION INSPECTION

Your ALR Chain Lever HOIST has been tested and conforms to ANSI/ASME B30.21 and HST-3 standards.

On completion of installation, but prior to your ALR Chain Lever Hoist being put into regular service, the following procedures should be carried out:

1. Check that all joints and fasteners are tight and secure.
2. Operate the hoist with both no load and full load, and check that the operation is smooth at all times.
3. Check operation of hoist brake, under light load and full load conditions.
4. Traveling units - run throughout the full extent of the runway, ensuring adequate clearance at all times.
5. Please ensure your ALR Test Certificate has been stored and the unit(s) have been placed in your lifting register for future reference.

4.0 Hoist Operation

4.1 Free Load Chain Principle

- 1) Free chaining allows the load chain to be moved freely because the brake is released under no load situation.
- 2) Pulling the Hand Wheel #5 actuates the Twisting Spring 1 #6 to release the mechanical brake allowing the load chain to be pulled in either direction to the desired length.
- 3) The brake is engaged during lowering or lifting the load.

4.2 Lifting and Lowering Operation - Operating the Lever Handle #10 with the Selector Lever set to the lifting "UP" or the lowering "DN" position, the lever hoist performs as follows:

- 1) Set the Selector Lever to the direction of load movement desired and ratchet the Lever Handle #10 back and forth. Refer to Table 1.
- 2) In lifting mode, the mechanical brake is engaged and supports the load on the pawls when the Lever Handle #10 stops.
- 3) In lowering mode, Lever Handle #10 operation releases the mechanical brake and lowers the load, when the Lever Handle #10 stops, the mechanical brake is engaged and supports the load.
- 4) The brake is always engaged in the lifting and lowering modes.
- 5) If Lever handle #10 movement does not produce lifting, pull down the load side of the load chain while ratcheting until load chain is not slack.

Selector Position	Lever Rotation	Load Movement
UP	Clockwise	Lift
DN	Counterclockwise	Lower

4.3 Introduction



LEVER OPERATED LEVER HOIST OPERATORS SHALL BE REQUIRED TO READ THE OPERATION SECTION OF THIS MANUAL, THE WARNINGS CONTAINED IN THIS MANUAL, INSTRUCTION AND WARNING LABELS ON THE HOIST OR LIFTING SYSTEM, AND THE OPERATION SECTIONS OF ANSI/ASME B30.16 AND ASME B30.10. THE OPERATOR SHALL ALSO BE REQUIRED TO BE FAMILIAR WITH THE MANUAL Lever Hoist AND HOIST CONTROLS BEFORE BEING AUTHORIZED TO OPERATE THE HOIST OR LIFTING SYSTEM.

LEVER OPERATED LEVER HOIST OPERATORS SHOULD BE TRAINED IN PROPER RIGGING PROCEDURES FOR THE ATTACHMENT OF LOADS TO THE HOIST HOOK.

LEVER OPERATED LEVER HOIST OPERATORS SHOULD BE TRAINED TO BE AWARE OF POTENTIAL MALFUNCTIONS OF THE EQUIPMENT THAT REQUIRE ADJUSTMENT OR REPAIR, AND TO BE INSTRUCTED TO STOP OPERATION IF SUCH MALFUNCTIONS OCCUR, AND TO IMMEDIATELY ADVISE THEIR SUPERVISOR SO CORRECTIVE ACTION CAN BE TAKEN.

HOIST OPERATORS SHOULD **NOT** HAVE A HISTORY OF OR BE PRONE TO SEIZURES, LOSS OF PHYSICAL CONTROL, PHYSICAL DEFECTS, OR EMOTIONAL INSTABILITY THAT COULD RESULT IN ACTIONS OF THE OPERATOR BEING A HAZARD TO THE OPERATOR OR TO OTHERS.

HOIST OPERATORS SHOULD **NOT** OPERATE A HOIST OR LIFTING SYSTEM WHEN UNDER THE INFLUENCE OF ALCOHOL, DRUGS, OR MEDICATION.

NOTICE

- . Read ANSI/ASME B30.21 and ANSI/ASME B30.10.
- . Read the Owner's Manual.
- . Read all warning labels and tag attached to Lever Hoist.

5.0 CARE IN USE

1. Always examine the hoist carefully prior to use - your life and others may be at risk. Look for cracks or damage, particularly with hooks and load chain.
2. Keep load chain clean and oiled to prevent undue damage or wear. When in use, avoid dragging the load chain through dirt or mud.
3. When the hoist is used outdoors or in a corrosive environment, ensure that it is regularly and adequately lubricated.
4. Do not operate the hoist if you do not have a clear view of the bottom hook and the load.

6.0 MAINTENANCE & INSPECTION

The maintenance instructions contained in this manual are intended as a guide to the necessary procedures to be carried out by competent and experienced personnel to prolong the service life of the unit. ALR Brands, do not accept responsibility either for the manner in which the instructions in this manual are observed or for any consequence thereof.

To maintain continuous and satisfactory operation, a regular inspection procedure must be initiated so that worn or damaged parts can be replaced before they become unsafe. The intervals of inspection must be determined by the individual application and are based upon the type of service to which the chain hoist will be subjected. The inspection of chain hoists is divided into two general classifications designated as frequent and periodic.

6.1 Inspection

General

The inspection procedure is based on ASME B30.21. The following definitions are from ASME B30.21 and pertain to the inspection procedure as follows.

Personnel Competence – Persons performing the functions identified in this volume shall meet the applicable qualifying criteria stated in this volume and shall through education, training, experience, skill, and physical fitness, as necessary, be competent and capable to perform the functions as determined by the employer or employer's representative.

Qualified Person – A person, who by possession of a recognized degree or certificate of professional standing, or who, by extensive knowledge, training, and experience, has successfully demonstrated the ability to solve or resolve problems relating to the subject matter and work.

Normal Service – that distributed service which involves operation with randomly distributed loads within the rated load limit, or uniform loads less than 65% of rated load for more than 15% of the time.

Heavy Service – that service which involves operation within the rated load limit which exceeds normal service.

Severe Service – that service which involves normal or heavy service with abnormal operating conditions.

Inspection Classification

Initial Inspection – Prior to initial use, all new, altered or modified hoists shall be inspected per the Frequent Inspection criteria.

Inspection Classification – the inspection procedure for hoists in regular service is divided into 3 general classifications based on the intervals which inspection should be performed. The intervals in turn depends on the nature of the critical components of the hoist and the degree of their exposure to wear, deterioration, or malfunction. The 3 general classifications are designated as **Preoperational Frequent** and **Periodic**.

Preoperational Inspection – Visual inspection performed before the first use of each shift with records not required.

Frequent Inspection – Visual examinations by the operator or designated person with intervals per the following criteria.

- 1) Normal service – monthly
- 2) Heavy service – weekly to monthly
- 3) Severe service – daily to weekly
- 4) Special or infrequent service – as recommended by a qualified person before and after each occurrence.

Periodic Inspection – Visual inspection by a designated person with intervals per the following criteria.

- 1) Normal service – monthly
- 2) Heavy service – weekly to monthly
- 3) Severe service – daily to weekly
- 4) Special or infrequent service – as recommended by a qualified person before and after each occurrence.

Preoperational Inspection – Visual inspection shall be made before the first use of each shift with records not required

- 1) All functional operating mechanisms for proper operation and adjustment, maladjustment and unusual sounds.
- 2) Hooks and safety latches in accordance with ASME B30.10

Frequent Inspection – Inspection should be made on a frequent basis as follows. Frequent inspections are observations made during operation for any defects or damage that may appear between period inspections. Evaluation and resolution of the results of frequent inspection shall be made by a designated person so that the Lever Operated Lever Hoist is maintained in a safety working condition.

- 3) All functional operating mechanisms for proper operation and adjustment, maladjustment and unusual sounds.
- 4) Lever Operated Lever Hoist brake system for proper operation.
- 5) Hooks and safety latches in accordance with ASME B30.10
- 6) Safety latches operation

Periodic Inspection – Inspection should be made on a periodic basis as follows. Evaluation and resolution of the results of periodic inspection shall be made by a designated person so that the Lever Operated Lever Hoist is maintained in safety working condition.

For inspections where load suspension parts of the hoists are disassembled, a load test per ASME B30.16 must be performed on the Lever Operated Lever Hoist after it is re-assembled and prior to its return to service.

- 1) Requirements of frequent inspection
- 2) Evidence of loose bolts & nuts.
- 3) Evidence of worn, corroded, cracked or distorted parts, such as hook, load pin, gears load chain.
- 4) Evidence of damaged or excessive wear of load sheave and idle heaves.
- 5) Evidence of worn or oid contaminated friction discs, worn pawls & ratchet.
- 6) Nameplate on Lever Hoist is illegible.
- 7) End connection of load chain.

Occasionally Use Hoist – Lever Hoists are used infrequently shall be inspected as follows prior to placing in service.

- 1) Hoist idle more than 1 month but less than 1 year: Inspect per Frequent Inspection criteria.
- 2) Hoist idle more than 1 year: Inspect per Periodic Inspection criteria.

Inspection Methods and Criteria

- 1) The items are based on those listed in ASME B30.16 for the Frequent and Periodic Inspection.
- 2) Frequent Inspection – NOT intended to involve disassembly of the Lever Operated Lever Hoist. Disassembly for further inspection would be required only if Frequent Inspection results so indicate. Disassembly for further inspection should only be performed by a qualified person trained in the disassembly and re-assembly of the Lever Operated Lever Hoist.
- 3) Periodic Inspection – Disassembly of the Lever Hoist is required. Disassembly for further inspection should only be performed by a qualified person trained in the disassembly and re-assembly of the Lever Operated Lever Hoist.

Parts should be from ALR or ALR’s Service Agents. Using ‘commercial’ or other manufacturer’s parts to repair the ALR Lever Hoist may cause load loss. www.alrlift.com or info@alrlift.com

WARNING - TO AVOID INJURY - Use only ALR supplied replacement parts. Parts may look alike, but ALR parts are made of specific materials or processed to achieve specific properties.

7.0 STORAGE OF HOIST

Note: Always store unit in a clean and dry area. Ensure that all repair and maintenance work is carried out by qualified personnel, using only the specified genuine parts from ALR.

If there are any questions or comments, please contact either your local supplier or ALR. ALR can also be reached at our web site: www.ALRLIFT.com or telephone at 1-833-ALR-LIFT.

The ALR ALH-Series Lever Hoists comply with ANSI/ASME B30.21 and HST-3 standards.

Record your purchase information here for quick reference:

Model No.:	Stock No.:	Serial No.:
Purchased From:		Date Purchased:

8.0 Specifications

8.1 Stock Number

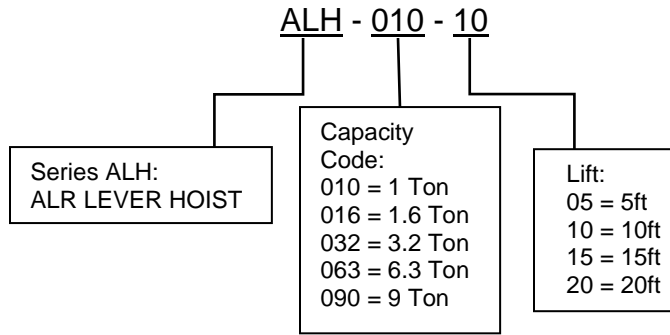

ALH Series Lever Operated Lever Hoist

Capacity	(tonnes)	1	1.6	3.2	6.3	9
Stock Number		ALH-010-05	ALH-016-05	ALH-032-05	ALH-063-05	ALH-090-05
No. of Falls		1	1	1	2	3
Load Chain Grade 100	(mm)	5.6×15.7	7.1×19.9	10×28	10×28	10×28
Pull to Rated Load	(N)	318	350	368	377	375
Pull to Rated Load	(lbf)	71.49	78.68	82.73	84.75	84.30
Proof Load	(tonnes)	1.5	2.4	4.8	9.5	13.5
Standard Lift	(ft)	5	5	5	5	5
Net Weight	(kg)	6	8.1	13.3	25.5	41
Gross Weight	(kg)	6.3	8.5	14.2	26.6	46.5
Extra Wt. per m	(kg)	0.7	1.1	2.3	4.7	7
Dimensions	a (mm)	146±0.5	164±0.5	196±0.5	196±0.5	196±0.5
	b (mm)	119±0.5	126±0.5	159±0.5	218±0.5	298±0.5
	c (mm)	245±0.5	265±0.5	415±0.5	415±0.5	415±0.5
	d (mm)	96±0.5	100±0.5	114±0.5	114±0.5	114±0.5
	e (mm)	31.5±1	35.5±1.5	43±1.5	53±2	64±2
	f (mm)	42.5±0.5	42.5±0.5	50±0.5	60±0.5	85±0.5
	g (mm)	49.4±1	52±1.5	61.9±1.5	84.3±2	
	h (mm)	300±1	335±1	395±1	540±1	680±1
t (mm)		15±0.5	19±0.5	24.5±0.5	34±0.5	40±0.5

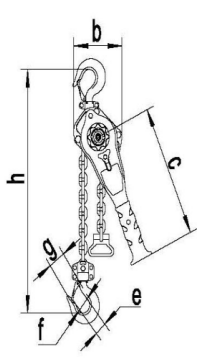
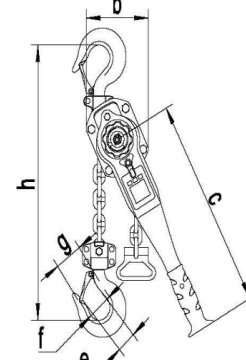
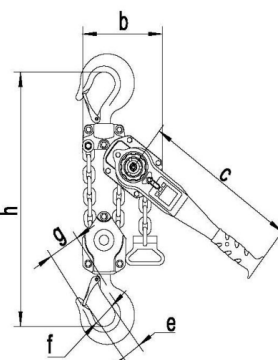
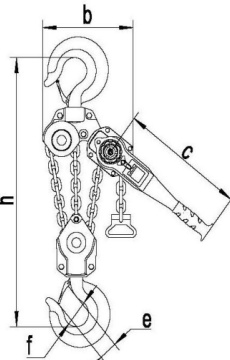
Note:

Suffix -OP indicates models with overload protection.

Suffix -SH indicates models with point ("shipyard") hooks. It is available for 1.6t & 3.2t.

9.0 Installation

Support for the hoist may be hook, clevis pin, trolley, or beam clamp. Whatever method of suspension is chosen, the support components **must** be rated equal to, or greater than the capacity of the lever hoist. Supporting structures (such as I-Beams, etc.) should be installed by properly licensed professional installers.

Pre-Operation Inspection

Inspecting the Load Chain

1. A chain stop must be attached to the last link of the slack end of the chain. See Figure 4.

⚠WARNING Do not operate the hoist with a twisted, kinked or damaged chain. Do not splice the chain.

2. Check that the chain does not twist along its length from hoist to hook. If twist is present on units with multiple falls, the hook must be passed back through the chain loop to remove all twist in the chain.
3. Replace the chain if links are stretched too long or seriously worn on the surface, especially at the points where links contact each other. See "Allowable Limits" on page 15 for measuring chain elongation.
4. Do not use a chain that is seriously rusted or cracked.
5. Periodically apply a light coat of 30-weight oil to the chain. This will create easier operation and prolong the chain's life. For optimum results, clean the chain with an acid-free solution before oiling.

⚠WARNING The load chain supplied with your ALR lever hoist is designed, manufactured, and tested for proper fit and durability. If chain should ever need replacing, for your own safety use factory replacement chain only. Use of other than factory replacement chain may cause serious injury and/or damage to the lever hoist.

Never extend load chain by welding a second piece to the original.



Figure 3
Features and terminology



Figure 4

Inspecting Hooks

It is important to check top and bottom hooks for proper opening and other signs of deformation or damage. Replace a hook immediately if any of the following problems are identified:

- The safety latch no longer contacts the hook opening.
- The vertical angle at the neck of the hook reaches 10° (see Figure 5).
- Chemical corrosion or cracks on the hook.
- Excessive wear on the inside surface.
- The throat opening has enlarged. (See page 15 for the maximum allowable limits for the throat opening.)

⚠ WARNING Do not attempt repair of a hook by heat treating, bending or attaching anything by welding. Such procedures will weaken and may cause failure of the hook.

Other Inspections

1. Check for appropriate clicking sounds: With the selector lever in UP position, there will be a clicking sound when the lever handle is rotated in *either direction*. When the selector lever is in DOWN position, there will be a clicking sound only when the lever handle is ratcheted back into position but not as the load is lowered. If these sounds are not present, or if *irregular* clicking noises develop, do not use the hoist – have it inspected and repaired by an authorized service center.
2. If the lever hoist has not been used for an extended period of time, check for proper operation before putting into service.
3. The brake mechanism must be kept clean and free from dirt, water, and oil. Never allow oil to penetrate the braking mechanism. The brake should not slip while using the hoist.

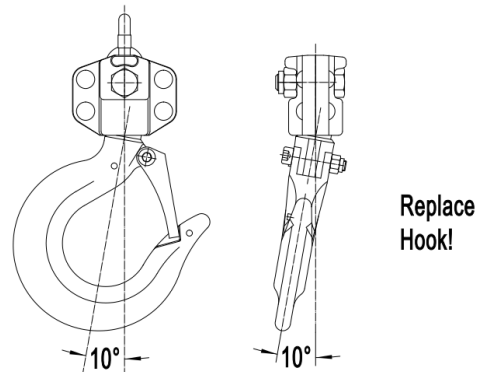

Figure 5

10.0 Operation

The ALH Lever Hoist may be used either in vertical position as a hoist; or in angled or horizontal position as a puller. Below is the general procedure for operating the hoist:

1. Set the top hook securely.
2. Place the selector switch on the handle in the center neutral position, and pull out on the handwheel (Figure 6). This will allow "free-wheel" mode. Pull the load chain by hand to position the bottom hook.
3. Correctly center the load on the bottom hook (Figure 7). Incorrect loading is dangerous to the operator, the lever hoist, and the load.
 - Never load the hook in front of the safety latch (A, Figure 8).
 - Never load the hook tip (B, Figure 8).
 - Never load the hook off the centerline (C, Figure 8).
 - Never load the hook sideways (D, Figure 8).
4. Rotate the handwheel clockwise while simultaneously pulling down on the load chain, as shown in Figure 5. The handwheel will snap back into place, re-engaging the gear.
5. Move selector switch to the UP position. Ratchet the lever to raise or pull the load. Do not overload the lever hoist.

⚠ WARNING Do not touch the handwheel while lifting or lowering. Do not operate freewheel mode while there is a load on the hoist.

6. To release or lower the load, turn selector switch on the handle to the DOWN position and ratchet the handle.

NOTE: If the chain is pulled too suddenly in free-wheel mode, the brake may set preventing further pulling. Re-set the hoist by repeating step number 4 above, and then set the hoist back into freewheel mode to continue the operation.

Avoid lifting one load with two hoists. If this is unavoidable, apply equal weight to both hoists and use hoists with the proper lift capacity. **Capacity of each hoist must be equal to the total load to be lifted.**

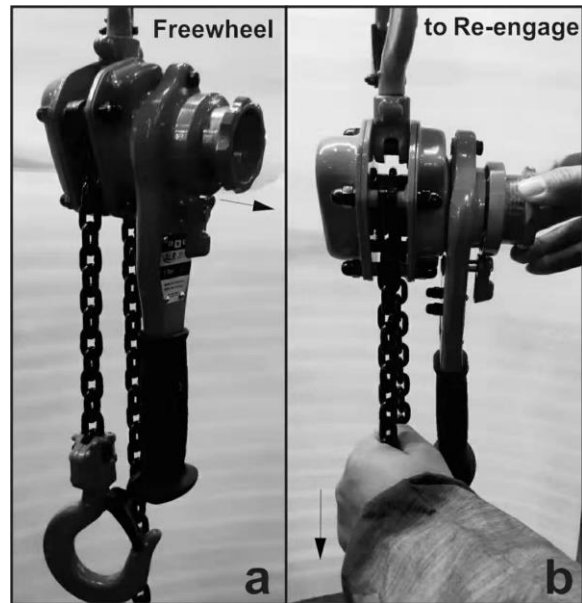

Figure 6

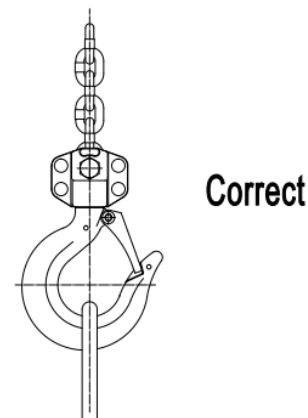

Figure 7

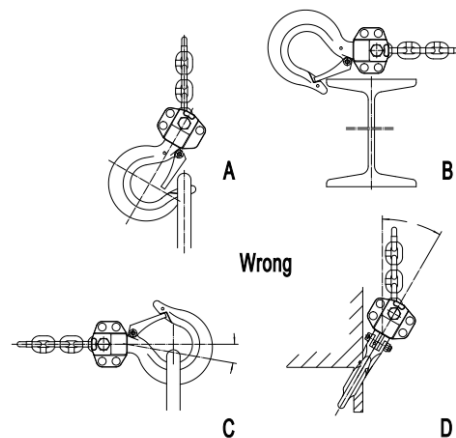

Figure 8

11.0 Precautions

- During lifting operations, do not stand under the load.
- Do not use any extension on the lever handle. Do not use your foot to apply pressure to the lever handle.
- Prevent the chain from dragging over sharp edges or corners. This will cause links to weaken, bend, or break.
- When connecting to a wire rope sling, the lever hoist must be applied along a straight line parallel to the surface on which it is resting. See Figure 9.
- When lifting loads, hook the load with slings. **Do not use the lever hoist chain as a sling** (Figure 10).
- Both ends of a sling or rope must be completely on the inside of the safety latch before pulling or lifting the load. Do not put one end on the inside of the latch and leave the other end on the hook end outside the latch.

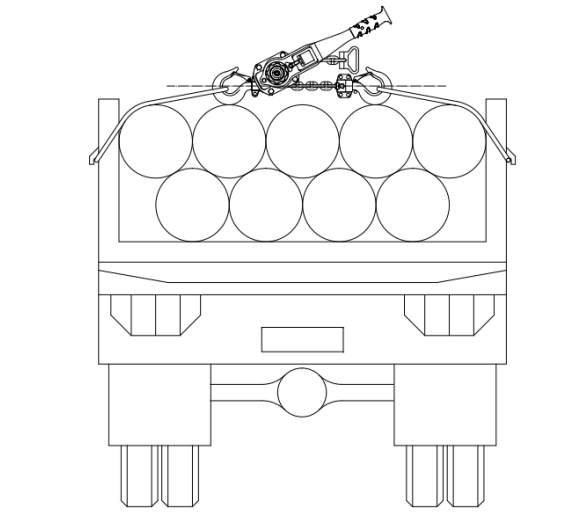

Figure 9

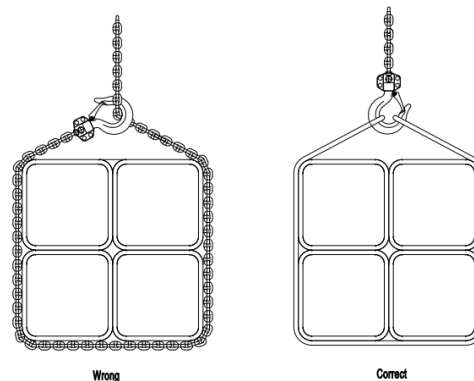

Figure 10

12.0 Point Hooks

Point or “shipyard” hooks are available for your ALR lever hoist, in 1.6 ton and 3.2 ton load sizes. They are available in both upper and lower hook styles.

Point hooks are used in the metal and ship building industries, and are designed for positioning steel plate and fixtures before welding.

13.0 Overload Protection

ALH Lever Hoist has an optional feature of overload protection in the form of a slip clutch (these are identified by “OP” in the model number). The slip clutch is effective at 200% of the rated hoist capacity.

The slip clutch will allow the lever handle to rotate without lifting the load, if the load is too heavy for the hoist. The slip clutch has been pre-adjusted at the factory and should not require any adjustment by the user. If future adjustment or repair to the slip clutch should ever be needed, this must be done by qualified personnel.

14.0 Inspection and Maintenance

Read and follow ANSI Inspection and Maintenance Instructions. Know the meaning of Frequent Inspection, Periodic Inspection, Normal Service, Heavy Service, and Severe Service. It is the customer’s responsibility to understand and follow all ANSI and ALR inspection and maintenance instructions.

The lever hoist should be stored in a clean, dry environment. Clean and oil the hoist before storage.

Hoists that are installed out-of-doors should be covered or brought inside when not in use.

Periodically apply a light coat of 30 weight oil to the load chain. Also lubricate

Annually, the hoist should be disassembled, inspected, and cleaned by trained and experienced personnel only. Contact a ALR authorized service center by calling your dealer or visiting our web site at ALRLIFT.com.

15.0 Allowable Limits for Load Chain and Hooks

Load Chain

Carefully inspect the entire load chain. As illustrated in Figure 11, measure nine consecutive links with calipers to find the length. Compare the results with the table in Figure 10. Check every three feet and especially where excessive wear is indicated. Any load chain that shows noticeable deformation or heat influence must be replaced with a new one.

⚠WARNING Never extend load chain by welding a second piece to the original.

16.0 Hooks (Top and Bottom)

Replace the hook when the distance between indicator points – “A” in Figures 12 – is wider than the limits given in the table.

Never heat treat the hook or attach anything to the hook by welding.

17.0 Timing Marks for Gear Replacement

If the gears on the ALH hoist need replacement or removal for any reason, make sure they are re-installed correctly. Figure 13 shows the proper orientation of the timing marks when meshing the gears.

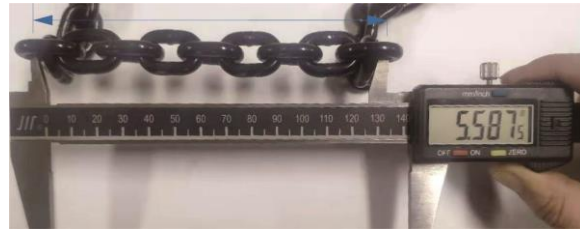
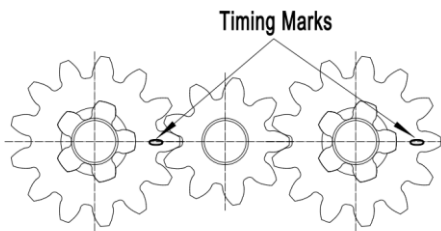

Capacity	9 Link Normal	9 Link MAX Limit (Replace if >)
1 ton	5.56"	5.73"
1.6 ton	7.05"	7.26"
3.2 ton	9.92"	10.22"
6.3 ton	9.92"	10.22"
9 ton	9.92"	10.22"

Figure 11

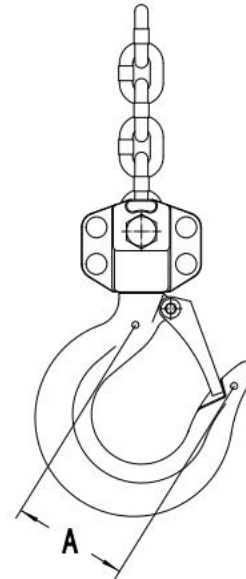

Capacity	Dimension Normal (A)	Dimension Limit (A)
1 ton	1.95"	2.15"
1.6 ton	2.05"	2.26"
3.2 ton	2.44"	2.68"
6.3 ton	3.32"	3.65"
9 ton	3.54"	3.89"

Figure 12

18.0 Troubleshooting

The numbers in parentheses refer to the parts breakdown on the following page.

Trouble	Probable Cause	Remedy*
Hoist will not lift (no clicking sound).	Pawl (#41) not engaging ratchet disc (#15); possible dirt or foreign material.	Clean and lubricate pawl/ratchet disc assemblies.
	Pawl spring (#42) is damaged.	Replace pawl spring.
	Selector switch spring (#35) is loose or damaged.	Tighten or replace selector switch spring.
Load slips or drifts while being lowered.	Dirt/corrosion/foreign material in hoist components.	Inspect and correct problem. Keep hoist clean and lubricated.
	Brake is slipping. Disc hub (#16) is worn from long-term use, or is damaged from overloading or misuse.	Replace disc hub. Do not overload hoist.
Hoist will not lower load.	The brake has caught. (Hoist was left under load condition for extended period, or was shock-loaded while operating.)	Place selector lever in DOWN position and pull hard on the lever handle to re-set the brake. Resume operation.
	Brake components are corroded or damaged.	Replace components as needed; keep hoist clean and lubricated.
Handwheel will not move in and out.	Disc hub (#16) is damaged.	Replace disc hub.
Hoist will not freewheel.	Brake has caught because load chain was pulled too hard.	Re-set by rotating handwheel clockwise while pulling down on load chain. Return hoist to freewheel mode and continue. Pull load chain less forcibly.

* Any disassembly or repair of the lever hoist should be performed by properly trained personnel. Call ALR, or go to ALRLIFT.com to find an authorized Service Center nearest you.

19.0 Replacement Parts

When ordering Parts, please provide the Hoist model number, and serial number located on the hoist nameplate (see Figure 14 below).



Figure 14 ALH Nameplate

Lever Hoist Parts

Replacement parts are listed on the following pages.

To order parts or reach our service department, call 1-833-ALR-LIFT, 8:00 TO 5PM, Monday through Friday. Having the Model Number and Serial Number of your lever hoist available when you call will allow us to serve you quickly and accurately.

ALH Lever Hoist Parts Breakdown

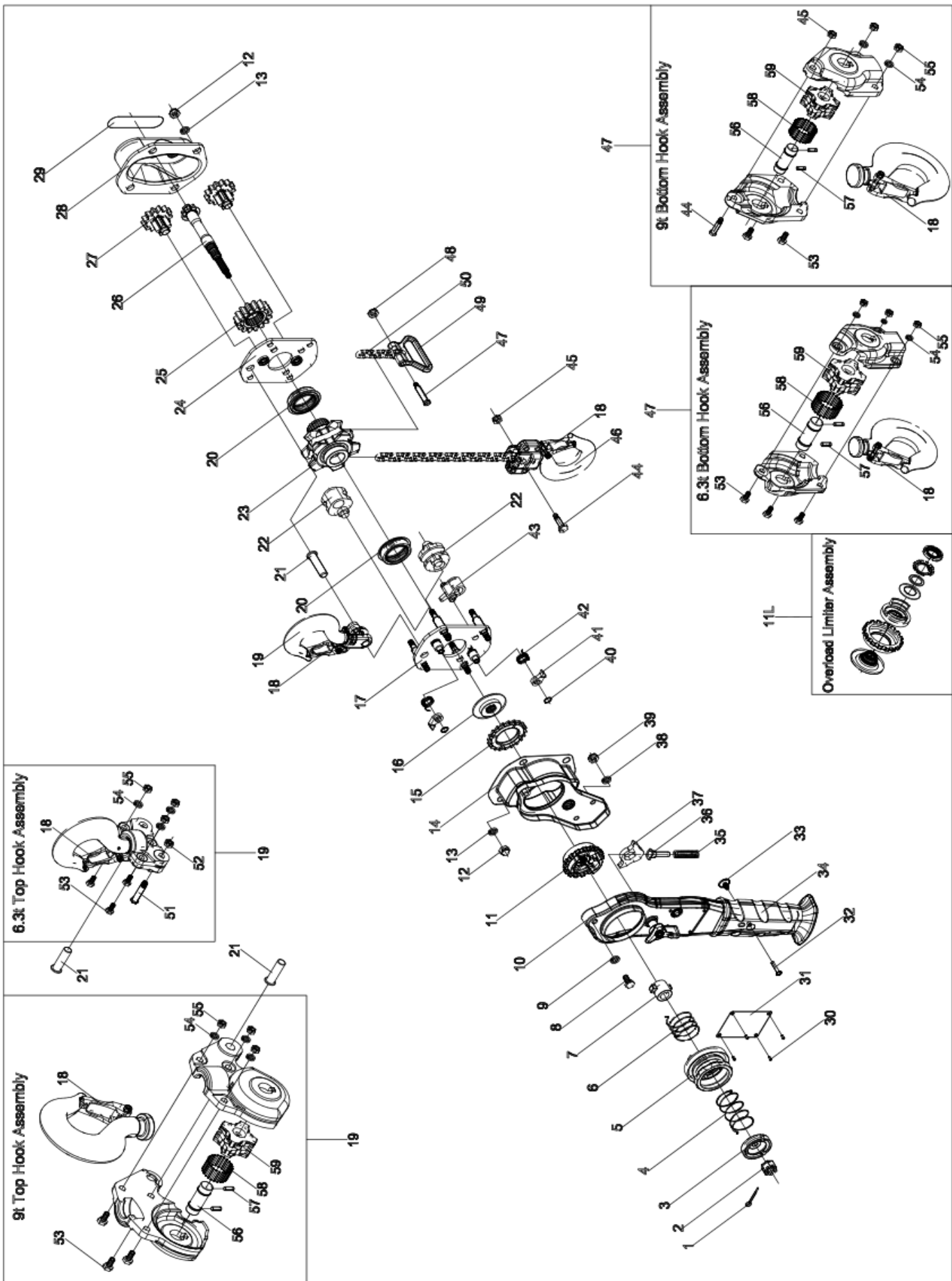

Record your purchase and installation information here

Purchased from: _____

Date: _____

Serial Number: _____

Model Number: _____

Stock Number: _____

Location Installed: _____

Date Installed: _____

Date in Service: _____

Strength - Safety - Reliability

Atlas Lifting & Rigging Lifting, LLC

WWW.ALRLIFT.COM

1-800-ALR-LIFT