

GB - Proton Gun

RIGHT Proton Gun Mech Assembly

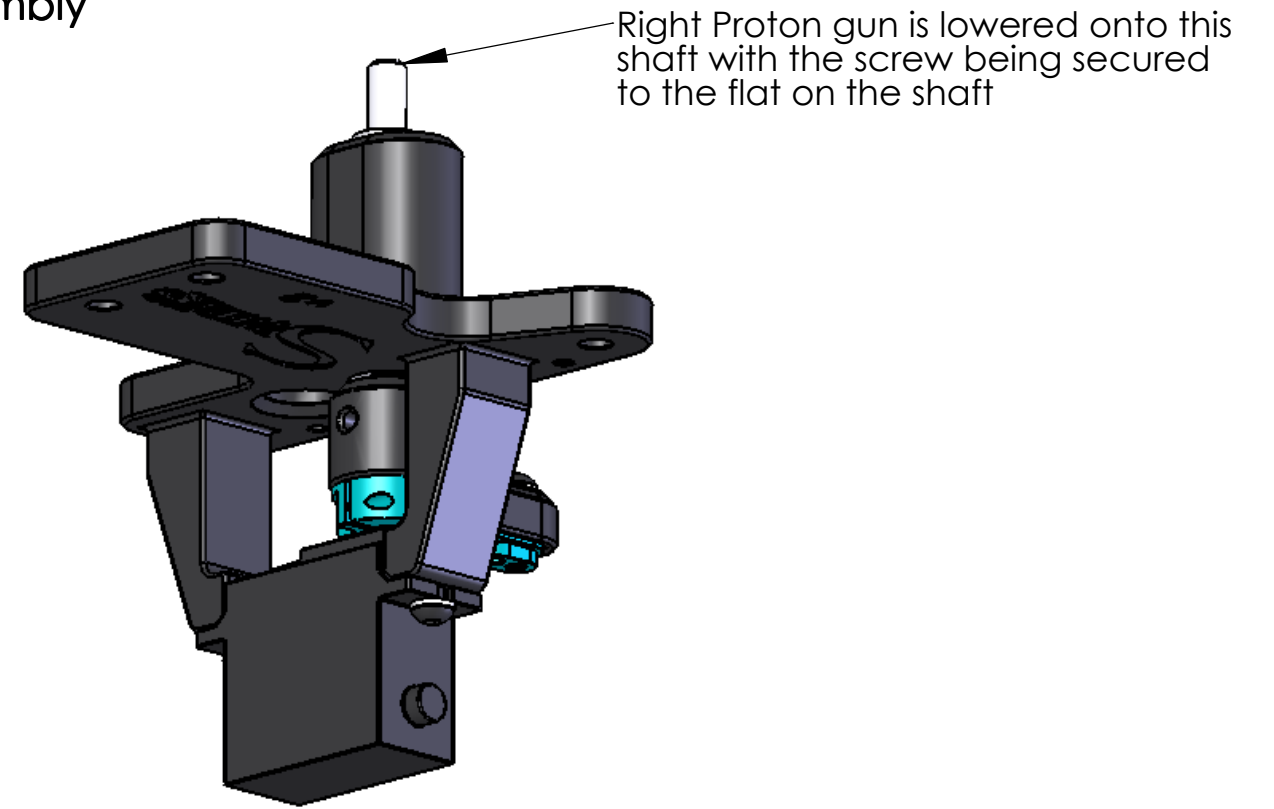
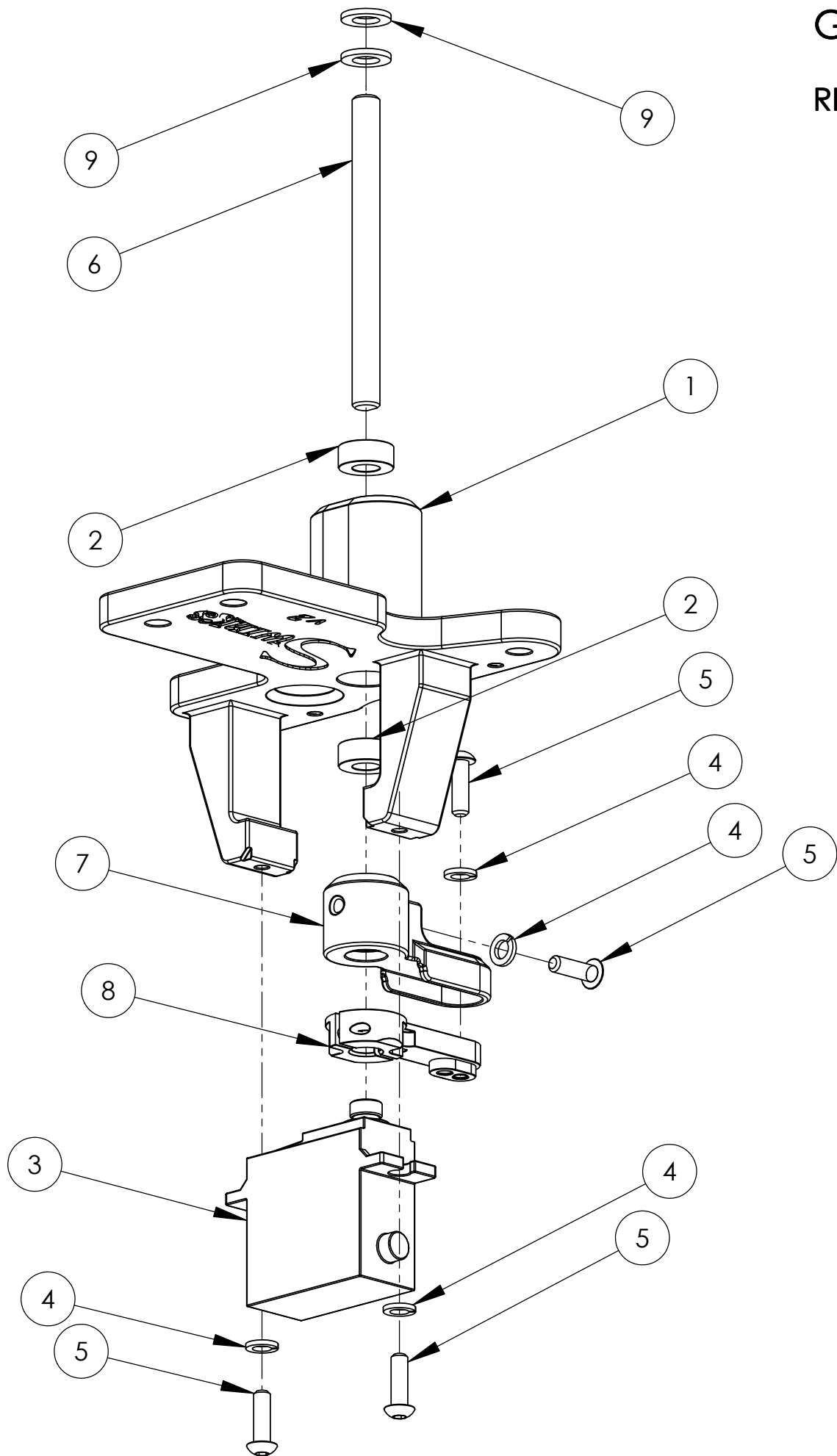

Notes:

- Item 2 Bearings will vary in fit from firm to a fraction loose - ensure not to lose
- Item 5 When un/securing the servo to Item 1 careful move the cable to the side
- Item 5 The secures the shaft to the pivot horn - secure bolt to flat of the shaft
- Item 8 Blue Servo Horn has 2 very small screws not drawn that clamp to the servo shaft as well as a screw locking the servo horn down to the servo shaft
- Item 9 Ensure washers are kept safe when guns are removed

Bolts to secure mech to playfield are not shown but install into the outer holes provided

Ensure Spring washers are used and nip up bolts so to avoid stripping of threads and cracking of parts - the spring washers are critical

ITEM NO.	Part Description	Notes	QTY.
1	3DP - Playfield Proton RHS Base v2		1
2	Bearing - Roller - 5mm ID x 10mm OD x 4mm thick		2
3	Servo - DGServo 505NF STD		1
4	Washer - 3mm Spring - Zinc		4
5	Button Screw - 3mm x 10mm Allen Headed - Black		4
6	SS - Proton Pivot Shaft v2		1
7	3DP - Pivot Horn v2		1
8	Servo - Horn Blue Aluminium		1
9	Washer - 5mm x 9mm - SS		2