



BIOLOGY – I
{ Chap 1 : Reproduction in Lower and Higher Plants }

Time : 1^{1/2} Hours

Total Marks : 25

SECTION – A

Q1. Select and write the correct answer :

[04]

I. A ditheous anther is -----.

- (A) trisporangiate (B) unisporangiate
 (C) tetrasporangiate (D) bisporangiate

II. Synergids show hair like projections called -----

- (A) funiculus (B) filiform apparatus
 (C) polar nuclei (D) antipodals

III. If diploid chromosome number in a flowering plant is 12 , then which one of the following will have 6 chromosomes ?

- (A) Cotyledons (B) Endosperm
 (C) Leaf cells (D) Synergids

IV. Polyembryony is commonly observed in -----

- (A) mango (B) orange
 (C) lemon (D) all these

Q2. Answer the following questions :

[03]

I. Define microsporogenesis.

II. Name the plants which exhibits both chasmogamous and cleistogamous flowers on the same plant.

III. Name the part of gynoecium that determines the compatible nature of pollen grain.

SECTION – B

Attempt any Four

[08]

- Q3. Sketch and label angiospermic embryo sac .
Q4. Write any four adaptations of hydrophilous flowers.
Q5. Write a short note on entomophily.
Q6. Write the significance of seed and fruit.
Q7. How polyembryony can be commercially exploited?
Q8. Define : Apogamy and Apospory.

SECTION – C

Attempt any Two

[06]

- Q9. Explain the categories of apomixis.
Q10. Draw neat and labelled diagram of dicot seed and monocot seed.
Q11. Incompatibility is a natural barrier in the fusion of gametes.
How will you explain this statement?

SECTION – D

Attempt any One :

[04]

- Q12. Explain in detail Pollen-Pistil interaction.
Q13. Describe the process of double fertilization.



MARCH 23



BIOLOGY – II
{ Chap 9 : Control and Coordination }

Time : 1^{1/2} Hours

Total Marks : 25

SECTION – A

Q1. Select and write the correct answer :

[04]

I. ----- is a neurotransmitter

- (A) ADH (B) Acetyl CoA
(C) Acetylcholine (D) Inositol

II. Corpus callosum is a nerve fibre bridge which connects -----

- (A) two cerebral hemispheres (B) cerebrum and cerebellum
(C) cerebellum and medulla (D) midbrain and hind brain

III. The innermost layer of human eye is -----

- (A) choroid (B) cornea
(C) sclera (D) retina

IV. Milk secretion in lactating women is controlled by -----

- (A) LH (B) Prolactin
(C) Relaxin (D) Oestrogen

Q2. Answer the following questions :

[03]

I. Define Post-synaptic neuron.

II. Which are silent areas of the brain ?

III. How does tongue detect the sensation taste ?

SECTION – B

Attempt any Four

[08]

- Q3. Write a note on psychological disorders.
 Q4. Distinguish between glucocorticoids and mineralocorticoids
 Q5. Sketch and label diagram showing ‘Formation of Spinal Nerve’.
 Q6. Distinguish between the sympathetic and parasympathetic nervous system on the basis of the effect they have on : 1.Heart beat 2. Urinary Bladder
 Q7. Injury to the medulla oblongata causes sudden death – Explain.
 Q8. Write a short note on neurogilia.

SECTION – C

Attempt any Two

[06]

- Q9. Sketch, label and describe the nervous system in Hydra.
 Q10. Describe briefly the structure of multipolar neuron.
 Q11. State the hormones secreted by hypothalamous and their functions.

SECTION – D

Attempt any One :

[04]

- Q12. Name the two regions of adrenal gland.
 Explain the regions and the hormones secreted in detail.
 Q13. Describe the structure shown in the given diagram.

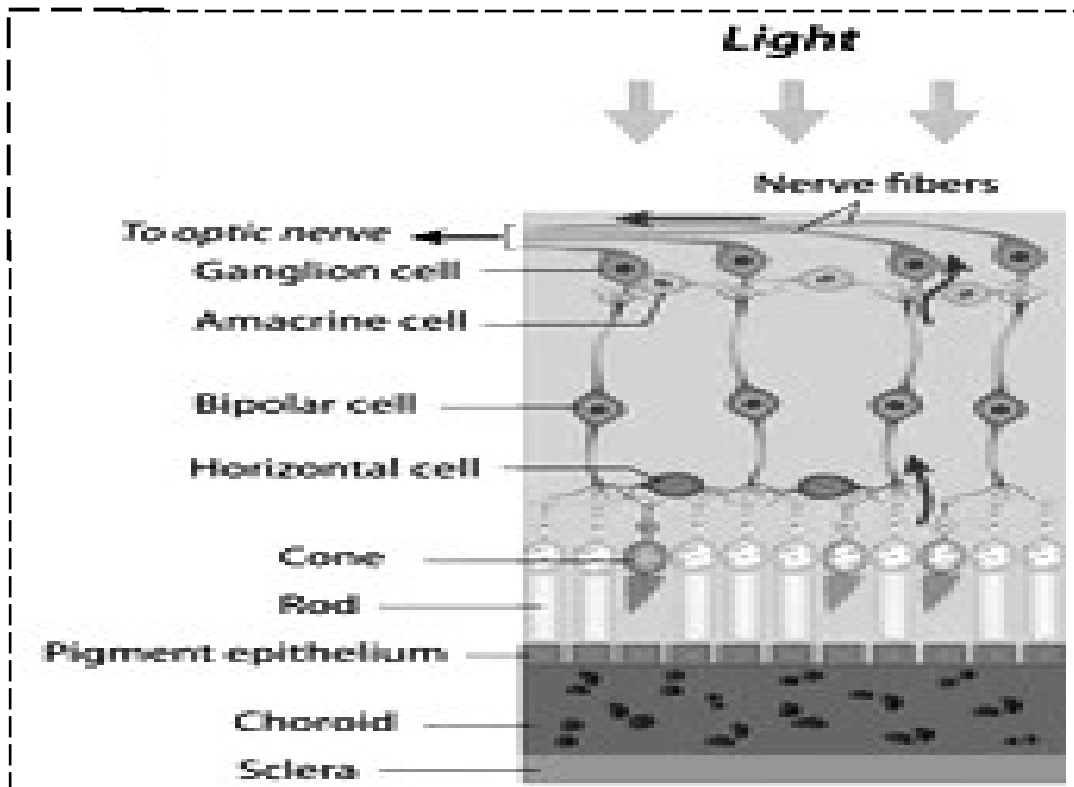

MARCH 23



CHEMISTRY – I
{ Chap 1 : Solid State }

Time : 1^{1/2} Hours

Total Marks : 25

SECTION – A

Q1. Select and write the correct answer :

[04]

I. The number of types of orthorhombic unit cell is -----.

- (A) 7 (B) 3
(C) 4 (D) 2

II. In crystal lattice formed by bcc unit cell, the void volume is -----

- (A) 68% (B) 74%
(C) 32% (D) 26%

III. Schottky defects are observed in which solid among the following ?

- (A) Silver iodide (B) Brass
(C) Zinc sulphide (D) Silver bromide

IV. Which of the following is an example of diamagnetic substance ?

- (A) CrO₂ (B) O₂
(C) Ni (D) NaCl

Q2. Answer the following questions :

[03]

I. Define : Packing efficiency.

II. Give examples of crystalline solids.

III. What are ferromagnetic substances ?

SECTION – B**Attempt any Four****[08]**

- Q3. What do you mean by isomorphism and polymorphism ?
- Q4. Ionic solids conduct electricity in molten state but not in solid state. Give reason.
- Q5. Explain the term : Unit cell
- Q6. How are tetrahedral and octahedral voids formed ?
- Q7. Tungsten crystallizes in bcc unit cell with edge length of 315.5 pm .
What is the radius of tungsten atom ?
- Q8. What are nonstoichiometric defects ? Give its types.

SECTION – C**Attempt any Two****[06]**

- Q9. Explain the band theory.
- Q10. What are p-type semiconductors ? Why is the conductivity of doped n – type semiconductor higher than that of pure semiconductor ?
Explain with diagram
- Q11. Obtain the relationship between density of a substance and the edge length of unit cell.

SECTION – D**Attempt any One :****[04]**

- Q12. a) Distinguish between crystalline and amorphous solids.
b) A metal crystallizes into two cubic faces namely face centered (fcc) and body centered (bcc), whose unit cell edge lengths are 4 A and 3.5 A respectively . Find the ratio of the densities of fcc and bcc.
- Q13. a) Distinguish between square close packing and hexagonal close packing in two dimensions.
b) Iron crystallizes in bcc structure with unit cell edge length of 287 pm.
What is the radius of Fe atoms ? How many unit cells are there in 3.00cm³ of Fe.

**MARCH 23**



CHEMISTRY – II
{ Chap 10 : Halogen Derivatives }

Time : 1^{1/2} Hours

Total Marks : 25

SECTION – A

Q1. Select and write the correct answer : **[04]**

I. IUPAC name of the following compound is -----.

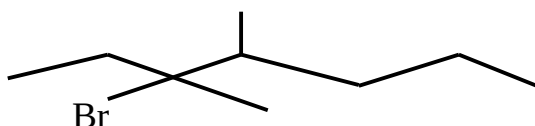

- (A) 3-bromo-3,4-dimethylheptane (B) 3,4-dimethyl-3-bromoheptane
 (C) 5-bromo-4,5-dimethylheptane (D) 4,5-dimethyl-5-bromoheptane

II. $C_2H_5 - Br + NaI \xrightarrow{\text{dry acetone}} C_2H_5 - I + NaBr$

- (A) Wurtz reaction (B) Sandmeyer reaction
 (C) Swarts reaction (D) Finkelstein reaction

III. The racemic mixture of an optically active compound is -----

- (A) dextrorotatory (B) laevorotatory
 (C) optically inactive (D) optically active

IV. The stability order for carbocation is -----

- (A) $2^\circ > 3^\circ > 1^\circ$ (B) $3^\circ > 2^\circ > 1^\circ$ (C) $3^\circ > 1^\circ > 2^\circ$ (D) $1^\circ > 3^\circ > 2^\circ$

Q2. Answer the following questions :

[03]

I. How boiling point of alkyl halides is determined ?

II. Give examples of allylic halide and Vinylic halide.

III. Mark the chiral carbon atoms in following compounds :

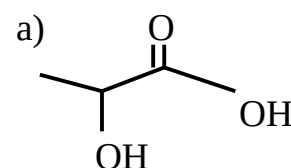
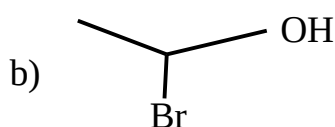

SECTION – B**Attempt any Four****[08]**

Q3. What is ordinary light ? What happens when ordinary light is passed through Nicol's prism ?

Q4. Draw structures of enantiomers of 2-bromobutane using wedge formula.

Q5. Convert the following using appropriate reagent.

a) methyl iodide to methyl acetate

b) 2-chloropropane to 2-methylpropanenitrile

Q6. Give a brief idea about changes that occur in substrate during nucleophilic substitution reactions (S_N).

Q7. Which of the following two compounds would react faster by S_N2 mechanism and Why ?

a) 1-chlorobutane b) 2-chlorobutane

Q8. Explain : but-2-ene is the preferred product during dehydrohalogenation of 2-bromobutane.

SECTION – C**Attempt any Two****[06]**

Q9. Aryl halides show low reactivity towards nucleophilic substitution reactions. Explain with suitable example.

Q10. Explain the following reactions with respect to chlorobenzene.

a) Nitration b) Sulfonation c) Friedel-Craft's reaction

Q11. Write a note on Freons.

SECTION – D**Attempt any One :****[04]**

Q12. a) Explain the method of preparation of alkyl halides using phosphorous halide.

b) Identify the products of the following reactions :

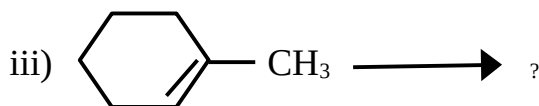
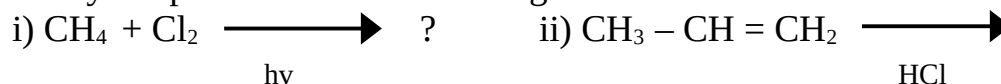

Q13. a) Write a note on halogen exchange reactions.

b) Explain Wurtz – fitting reaction.



MARCH 23



PHYSICS– I
{ Chap 1 : Rotational Dynamics }

Time : 1^{1/2} Hours

Total Marks : 25

SECTION – A

Q1. Select and write the correct answer : [04]

I. A body of mass 'm' performs uniform circular motion along a circular path of radius 'r' with velocity 'v'. If its angular momentum is 'L', then the centripetal force acting on it is -----.

(A) L^2 / mr (B) L^2 / mr^2 (C) mL^2 / r^3 (D) L^2 / mr^3

II. Two bodies of mass 10kg and 5 kg are moving in concentric orbits of radius R and r . If their time periods are same, then the ratio of their centripetal acceleration is -----.

(A) r/R (B) R^2/r^2 (C) r^2/R^2 (D) R/r

III. Rotational K.E. of a body is 10J. If the angular momentum vector coincides with the axis of rotation and its M.I. about this axis is 5kgm^2 then its angular momentum is -----

(A) 10 SI units (B) 40 SI units (C) 30 SI units (D) 20 SI Units

IV. The angular momentum of a wheel changes from 2L to 5L in 3 second . What is the magnitude of the torque acting on it ?

(A) L (B) L/5 (C) L/2 (D) L/3

Q2. Answer the following questions : [03]

I. Define : Uniform Circular Motion

II. What will happen if one raves fast over a speed breaker ? Why ?

III. What is Simple Pendulum.

SECTION – B

Attempt any Four [08]

Q3. Distinguish between Uniform Circular Motion and Non-uniform Circular Motion.

Q4. Explain the concept : Centrifugal Force

Q5. Explain why are curved roads banked ?

Q6. a vehicle is moving on a circular track whose surface is inclined towards the horizon at an angle of 20° . the maximum velocity with which it can move safely is 36 km/hr. Calculate the length of the circular track. ($\pi = 3.142$)

Q7. In a circus, a motor-cyclist having mass of 50kg moves in a spherical cage of radius 3m. Calculate the least velocity with which he must pass the highest point without losing contact. Also calculate his angular speed at the higher point.

Q8. Explain the relation of diving in swimming pool with the principle of conservation of angular momentum.

SECTION – C

Attempt any Two

[06]

Q9. Explain interlink between translational, rotational and total kinetic energies of a rigid object that rolls without slipping.

Q10. Derive an expression for maximum possible speed for a vehicle to move on horizontal unbanked road.

Q11. Semi-vertical angle of the conical section of a funnel is 37° . There is a small ball kept inside the funnel. On rotating the funnel, the maximum speed that the ball can have in order to remain in the funnel is 2 m/s . Calculate inner radius of the brim of the funnel. Is there any limit upon the frequency of rotation ? How much is it ? Is it lower or upper limit ? Give a logical reasoning. (Use $g = 10\text{m/s}^2$, and $\sin 37^\circ = 0.6$)

SECTION – D

Attempt any One :

[04]

Q12. a) Derive an expression for kinetic energy of a rotating body.

b) Explain the significance of moment of inertia.

Q13. a) Derive an expression that relates angular momentum with the angular velocity of a rigid body.

b) Thin uniform rod of mass 3kg and 2kg starts from rest and rotates about an axis passing through its centre and perpendicular to its length with a speed 1200 r. p. m for 10 seconds. Find torque acting on it.



MARCH 23



PHYSICS– II
{ Chap 8 : Electrostatics }

Time : 1^{1/2} Hours

Total Marks : 25

SECTION – A

Q1. Select and write the correct answer : **[04]**

I. The relation between electric charge, electric potential and capacity is -----
(A) $C = Q/V$ (B) $C = V/Q$ (C) $V = QC$ (D) None of these

II. The permittivity of medium is $35.4 \times 10^{-12} \text{ C}^2/\text{Nm}^2$. The dielectric constant of the medium will be -----
(A) 3 (B) 2 (C) 4 (D) 1

III. Energy stored in a capacitor and dissipated during charging a capacitor bear a ratio -----
(A) 1:1 (B) 2:1 (C) 1:3 (D) 1:2

IV. In a uniform electric field, a charge of 4 C experiences a force of 4000N. The potential difference between two points 2 cm apart along the electric lines of force will be -----
(A) 10V (B) 20V (C) 4 V (D) 0.2 V

Q2. Answer the following questions : **[03]**

I. The charge per unit area of a large flat sheet of charge is $4 \mu\text{C}/\text{m}^2$. Calculate the electric field intensity at a point just near the surface of the sheet, measured from its midpoint.

II. Define : Electrostatic Potential Energy of a system of potential charges.

III. State the reason : Restricted movements of charge carriers in electrolytic conductors.

SECTION – B

Attempt any Four **[08]**

Q3. What is electric susceptibility of dielectric medium.

Q4. Capacity of a parallel capacitor with dielectric constant 5 is $40 \mu\text{F}$.

Calculate the capacity of the same capacitor when dielectric material is removed.

Q5. Write a note on zero potential.

Q6. A small particle carrying a negative charge of 1.6×10^{-19} C. is suspended in equilibrium between two horizontal metal plates 10cm apart having a potential difference 3000V across them. Find the mass of the particle.

Q7. Explain electrostatic shielding with examples.

Q8. Explain : Energy storing in a capacitor.

SECTION – C

Attempt any Two

[06]

Q9. A $7\mu\text{F}$ capacitor is charged by a 200 V supply. It is then disconnected from the supply and is connected to another uncharged $3\mu\text{F}$ capacitor. How much electrostatic energy of the first capacitor is lost in the form of heat and electromagnetic radiation ?

Q10. Derive an expression for electric field intensity due to uniformly charged spherical shell or hollow sphere.

Q11. a) One hundred twenty five small liquid drops, each carrying a charge of $0.5\mu\text{C}$ and each of diameter 0.1 m form a bigger drop. Calculate the potential at the surface of the bigger drop. b) Why no work is done to move a charge anywhere in the equatorial plane of electric dipole. Explain.

SECTION – D

Attempt any One :

[04]

Q12. Describe construction and working of a Van de Graaff generator.

Q13. a) What is meant by equipotential surface ? Explain its properties.

b) Explain polarization of a polar dielectric in an external electric field.



MARCH 23



MATHEMATICS– I
{ Chap 1 : Mathematical Logic }

Time : 1^{1/2} Hours

Total Marks : 25

SECTION – A

Q1. Select and write the correct answer : **[04]**

I. The logically equivalent statement of $\sim p \vee \sim q$ is -----.

(A) $p \wedge q$ (B) $\sim p \wedge \sim q$ (C) $\sim(p \wedge q)$ (D) $\sim(p \vee q)$

II. Negation of $\sim(p \vee q)$ is -----.

(A) $p \wedge \sim q$ (B) $\sim p \wedge \sim q$ (C) $p \vee \sim q$ (D) $\sim p \vee \sim q$

Q2. Answer the following questions : **[03]**

I. Write Truth values of the following : If $3 \times 4 = 7$ then $3 + 4 = 12$.

II. Write the negations of the following : $11 < 15$ and $25 > 20$

III. Rewrite the following statements without using If ---- then : If 2 is a rational number then $\sqrt{2}$ is irrational number .

SECTION – B

Attempt any Four

[08]

Q3. Express the given circuit in the symbolic form of logic and write the input-output table.

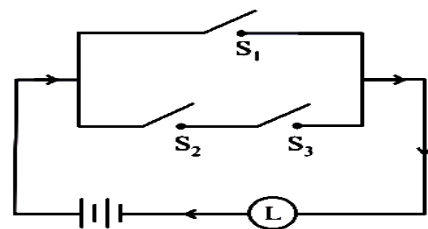

Q4. Prepare the truth table of $(p \wedge q) \rightarrow (\sim p)$

Q5. Using rules in logic, prove the following : $\sim(p \vee q) \vee \sim(p \wedge q) = \sim p$

- Q6. Using the rules in logic , write the negations of given case : $(p \rightarrow q) \wedge r$
 Q7. Write the truth values of the given statement : $\sqrt{5}$ is an irrational but $3\sqrt{5}$ is a complex number.
 Q8. Determine whether the given statement pattern is tautologies contradictions or contingencies : $(p \rightarrow q) \wedge (p \wedge \sim q)$

SECTION – C

Attempt any Two **[06]**

- Q9. Simplify the following so that the new circuit has minimum number of switch.
 Draw the simplified circuit.

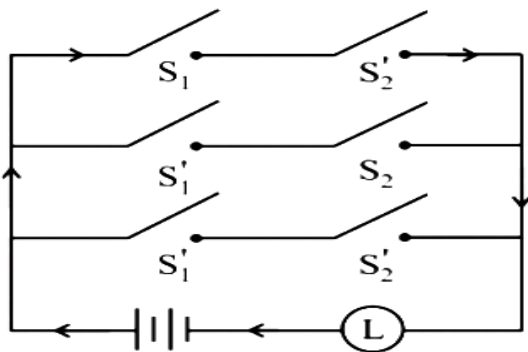

- Q10. Construct the switching circuit of the following : $(p \wedge q) \vee (\sim p) \vee (p \wedge \sim q)$
 Q11. Obtain the simple logical expression and draw the corresponding switching circuit
 $[p \vee (\sim q \vee \sim r)] \wedge [p \vee (q \wedge r)]$

SECTION – D

Attempt any One : **[04]**

- Q12. Simplify the following so that the new circuit has minimum switches.

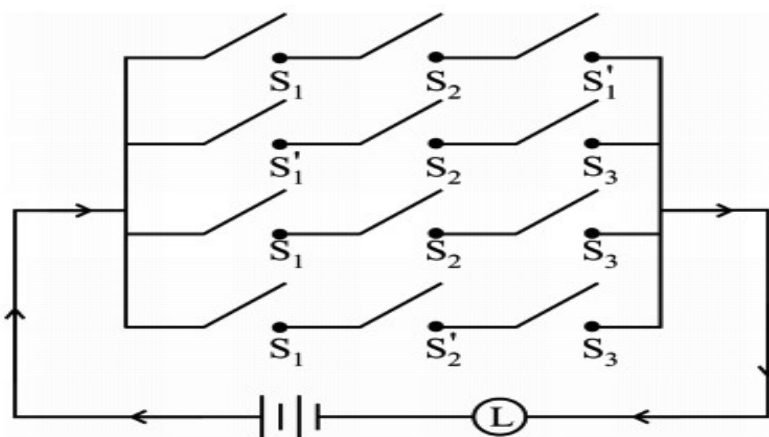

Q13. a) Construct the switching circuit of the following :

$$[(p \wedge r) \vee (\sim q \wedge \sim r)] \wedge (\sim p \wedge \sim r)$$

b) Write symbolic form ,switching table and interpretation for the following circuit

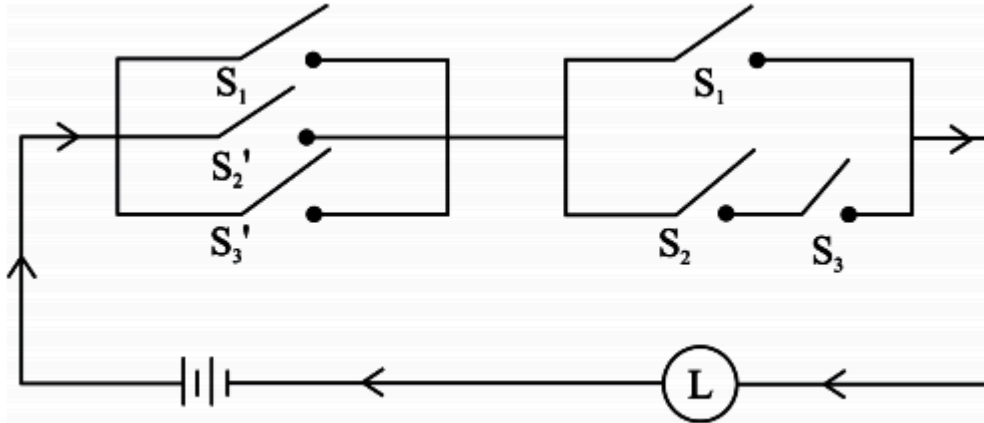

MARCH 23



MATHEMATICS– II
{ Chap 1 : Differentiation }

Time : 1^{1/2} Hours

Total Marks : 25

SECTION – A

Q1. Select and write the correct answer : **[04]**

I. If $y = \log (\tan x^\circ + \sec x^\circ)$, then dy/dx is -----.

(A) $\sec x^\circ$ (B) $1/\sec x^\circ$ (C) $180 / \pi \sec x^\circ$ (D) $\frac{\pi}{180} \sec x^\circ$

II. If $y = \sec (\tan^{-1} x)$ then dy/dx at $x = 1$, is equal to : -----.

(A) $1/2$ (B) 1 (C) $1/\sqrt{2}$ (D) $\sqrt{2}$

Q2. Answer the following questions : **[03]**

I. If $f(x) = \frac{x^2 - a^2}{x^2 + a^2}$ and $f'(1) = 1$, then find a .

II. $(f \circ g)(x) = x$

III. Differentiate $\sin(x^2 + x)$ w.r.t x

SECTION – B

Attempt any Four **[08]**

Q3. Differentiate w.r.t x : $\cos(x^2 + a^2)$

Q4. If $y = \tan^{-1} x$, $x \in \mathbb{R}$, $-\pi/2 < y < \pi/2$, then $dy/dx = 1 / 1 + x^2$

Q5. Find the derivative of the function $y = f(x)$ using the derivative of the inverse function $x = f^{-1}(y)$: $y = \sqrt{x}$

Q6. Differentiate the following w.r.t x : $\tan^{-1}(\log x)$

Q7. Find dy/dx , If $x\sqrt{x} + y\sqrt{y} + a\sqrt{a}$

Q8. If $e^x + e^y = e^{x+y}$, then show that $dy/dx = -e^{y-x}$.

Attempt any Two**[06]**Q9. Differentiate x^x w.r.t $x^{\sin x}$ Q10. If $2y = \sqrt{x+1} + \sqrt{x-1}$, show that $4(x^2 - 1)y_2 + 4xy_1 - y = 0$.Q11. Find the n^{th} derivative of the following : $(ax + b)^m$ **SECTION – D****Attempt any One :****[04]**Q12. Differentiate the following w.r.t. x : $\tan^{-1}(\operatorname{cosec} x + \cot x)$ Q13. Differentiate the following w.r.t x : $(\sin x)^{\tan x} + (\cos x)^{\cot x}$ **MARCH 23**