

Curv-Rite Stable Edge
 Aluminum Paver Restraint
 1-800-366-2878

1.) Outside Paver Detail

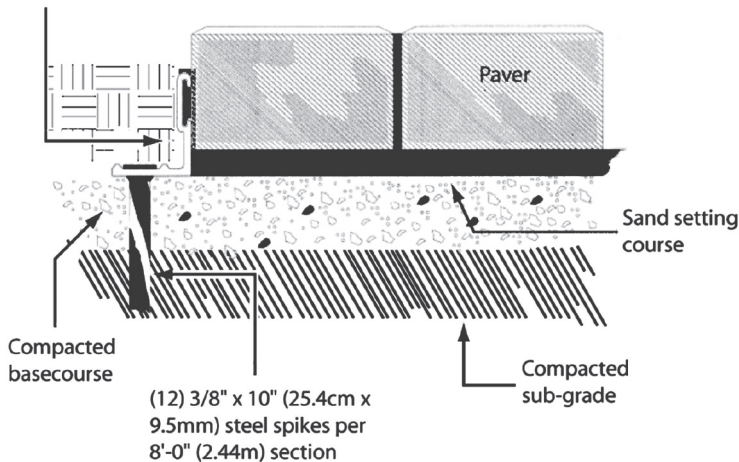

Check Desired Size:

- 1/8" x 1- 5/8" (3.2mm x 41mm)

Check Desired Finish:

- Mill Finish** - natural aluminum.
 Deco-Black - electrostatically applied baked on paint.

Technical Notes:

1. Refer to manufacturer's installation instructions with this product from, Curv-Rite Wayland, MI 1-800-366-2878.
2. Connection between strips to utilize manufacturer's Unique interlocking splicer.
3. Do not scale drawing.
4. Curv-Rite Stable Edge as manufactured by Curv-Rite, Inc. Wayland, MI 1-800-366-2878, (269) 792-0044 (269) 792-8126.

Technical Specifications:

Brick paver edging to be Stable Edge 1/8" x 1- 5/8" "L" shaped aluminum paver restraint in an 8' section as manufactured by Curv-Rite, Inc.; Wayland, MI 1-800-366-2878. Sections to be aluminum alloy 6063 with a T-6 hardness. A 3" aluminum splicer inserted 1 - 1/2" into each adjoining section shall be used to create an uninterrupted edging system that has a continuous support system on both sides of the vertical wall. Edging base shall have holes on 4" centers along length of section for receiving 3/8" x 10" spiral steel spikes. (specify quantity of spikes per section-up to 25 maximum) spikes shall be used per section.

Edge Detail-Sand Set Paver Installation

Curv-Rite® Stable Edge® Aluminum Paver Restraint

Copyright © 2010 Curv-Rite, Inc.

3603 North Main Street Wayland, MI
 800-366-2878 www.curv-rite.com