



VALIDATION SUMMARY REPORT

Walk-in Refrigeration Storage / Cold Room

Title: Validation Summary Report for Walk-in Refrigerated Trailer Model PKM612

Manufacturer:	Polar King International, Inc.
Model Number:	PKM612
Equipment ID / Serial No:	A230712632

Revision Number: 1
Issue Date: 11/22/2023



Manufacturer:	Polar King International, Inc.
Model Number:	PKM612
Equipment ID / Serial No:	A230712632

Table Of Contents

1.0	INTRODUCTION	3
2.0	REFERENCES	3
3.0	SUMMARY	3
3.1	INSTALLATION & QUALIFICATION	3
3.1.1	System Components Identification.....	3
3.1.2	Documentation Verification	3
3.1.3	Refrigeration System Components Visual Inspection.....	3
3.1.4	Electrical Supply Verification	3
3.1.5	Thermostatic Controller Identification	4
3.1.6	Refrigeration System Spare Parts	4
3.2	OPERATION QUALIFICATION.....	4
3.2.1	Vaisala Validation Equipment Calibration Verification.....	4
3.2.2	Temperature Data Logger Placement	4
3.2.3	24-HR Empty Unit Thermal Mapping (35°F Set Point).....	5
3.2.4	Empty Unit Open Door Temperature Recovery (35°F Set Point)	6
3.2.5	Empty Unit Power Failure Test (35°F Set Point)	7
3.2.6	24-HR Empty Unit Thermal Mapping (0°F Set Point).....	7
3.2.7	Empty Unit Open Door Temperature Recovery (0°F Set Point)	8
3.2.8	Empty Unit Power Failure Test (0°F Set Point)	8
3.3	Qualification Deviations	8
4.0	CONCLUSION	8
5.0	APPROVALS	9
6.0	Vaisala RFL100 Specifications	10
7.0	Polar Leasing PKM612 Unit Line Drawing	14



Title: Validation Summary Report for Walk-in Refrigerated Trailer Model PKM612

Manufacturer:	Polar King International, Inc.
Model Number:	PKM612
Equipment ID / Serial No:	A230712632

1.0 INTRODUCTION

The Validation Summary Report summarizes the qualification activities measured on the Walk-In Refrigerated Trailer, Polar King Mobile Unit A230712632. The unit is manufactured by Polar King International, Inc. and has a model number of PKM612. It is controlled by a GOVI Arktik 2000US refrigeration system. This summary also covers any discrepancies encountered throughout the validation study.

2.0 REFERENCES

Temperature mapping of storage area, technical supplement to WHO Technical Report Series, No. 961, 2011.

3.0 SUMMARY

3.1 INSTALLATION & QUALIFICATION

The validation study for A230712632 was completed on August 30th, 2023. Verifications for the study were documented and saved using Vaisala Veriteq vLog.

3.1.1 System Components Identification

Identification information for the Refrigerated Trailer was verified. This included model and serial numbers for the condensing unit, compressor, and structure. Refrigerant type and expansion valve were confirmed, as was insulation thickness.

3.1.2 Documentation Verification

Documentation for installation and maintenance of A230712632 was obtained. These documents were reviewed, and include manuals, CAD drawings, quality control reports and production worksheets.

3.1.3 Refrigeration System Components Visual Inspection

Documentation for installation and maintenance of A230712632 was obtained. These documents were reviewed, and include manuals, CAD drawings, quality control reports and production worksheets.

3.1.4 Electrical Supply Verification

A Fluke Multimeter was used to confirm the provided voltage supply was in accordance with requirements specified on the serial plate of the Refrigerated Trailer.



Title: Validation Summary Report for Walk-in Refrigerated Trailer Model PKM612

Manufacturer:	Polar King International, Inc.
Model Number:	PKM612
Equipment ID / Serial No:	A230712632

3.1.5 Thermostatic Controller Identification

The installation location of the thermostatic control was noted and documented as required. All set points used for testing were documented as necessary.

3.1.6 Refrigeration System Spare Parts

No spare parts are required for the Validation Summary.

3.2 OPERATION QUALIFICATIONS

3.2.1 Vaisala Validation Equipment Calibration Verification

Calibration documentation for (14) Vaisala RFL100 was reviewed and all temperature data loggers were found to have been calibrated in the last 18 months.

3.2.2 Temperature Data Logger Placement

The set-up of all temperature monitoring loggers was done in accordance with acceptable usage practices, obtaining measurements at multiple low, medium and high points within the Refrigerated Trailer. A total of 13 data points were logged in each study, as shown in Figure 1. Logger #14 was used to record ambient temps.

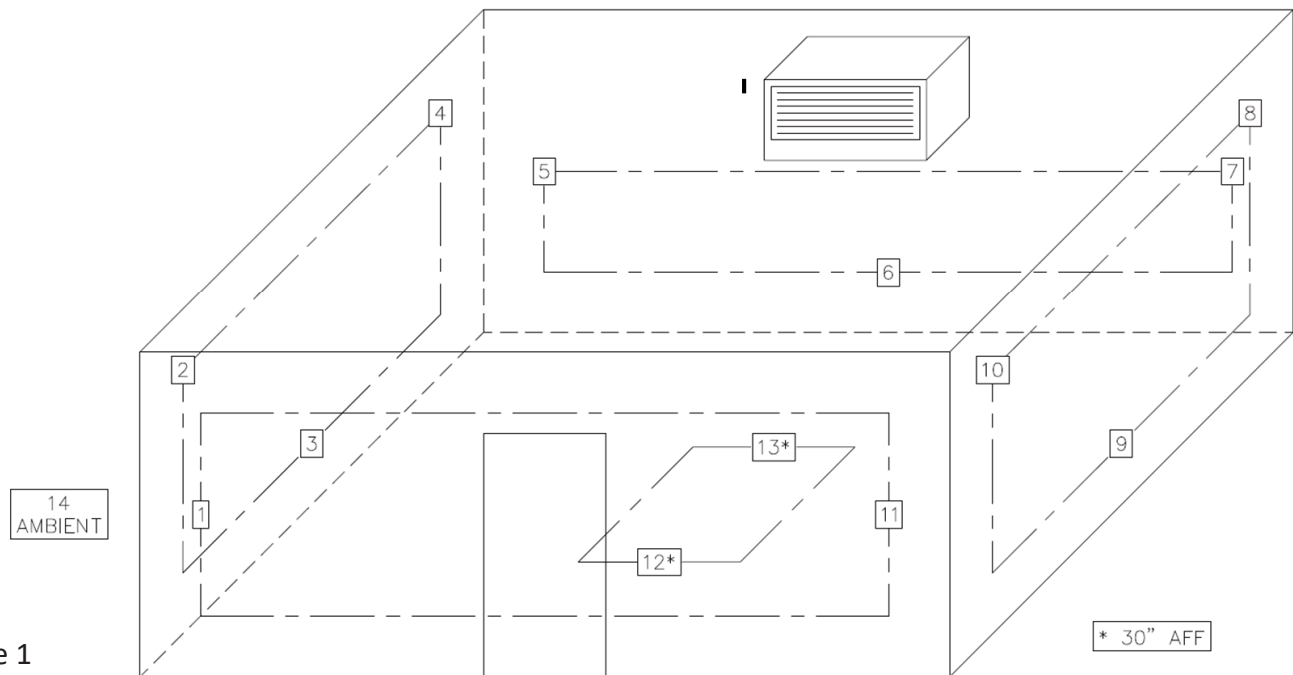

Figure 1



Title: Validation Summary Report for Walk-in Refrigerated Trailer Model PKM612

Manufacturer:	Polar King International, Inc.
Model Number:	PKM612
Equipment ID / Serial No:	A230712632

Table 1: Temperature Data Logger Locations and Labels

Data Logger Location	Data Logger Label	Alternate Data Logger Label
1	Probe #1	1171
2	Probe #10	1277
3	Probe #11	1279
4	Probe #12	1281
5	Probe #13	1283
6	Probe #2	1174
7	Probe #3	1176
8	Probe #4	1269
9	Probe #5	1178
10	Probe #6	1271
11	Probe #7	1273
12	Probe #8	1269
13	Probe #9	1275
14	Probe #14	1285

3.2.3 24-HR Empty Thermal Mapping (35°F Set Point)

At a set point of 35°F the Refrigerated Trailer was tested empty, with the door closed. Temperature data loggers were positioned as shown in Figure 1. Temperature data was recorded for a 24-hour period, from 03:00pm EDT on 08/27/23 to 03:00pm EDT on 08/28/23. The data was logged at 1-minute intervals. Individual graph and data reports, as well as a summary data report have been included as appendices. The summarized data for all 13 temperature data loggers can be found in Table 2.

Average ambient temperature during the test was 70.49°F, with a max of 95.00°F and min of 56.75°F.



Title: Validation Summary Report for Walk-in Refrigerated Trailer Model PKM612

Manufacturer:	Polar King International, Inc.
Model Number:	PKM612
Equipment ID / Serial No:	A230712632

Table 2: Temperature Data Logger Locations and Labels

Data Logger Location	Data Logger Label	Data Logger Label (Alternate)	Avg. Temp (°F)	Min. Temp (°F)	Max. Temp (°F)
1	Probe #1	1171	37.59	35.51	39.56
2	Probe #10	1277	36.92	33.53	39.29
3	Probe #11	1279	37.23	33.89	39.65
4	Probe #12	1281	37.14	34.07	39.38
5	Probe #13	1283	37.09	33.17	39.65
6	Probe #2	1174	37.09	33.62	39.47
7	Probe #3	1176	37.45	35.06	39.47
8	Probe #4	1269	37.72	36.41	39.11
9	Probe #5	1178	38.05	36.59	39.74
10	Probe #6	1271	37.58	36.32	38.75
11	Probe #7	1273	37.56	35.51	39.38
12	Probe #8	1269	37.47	35.51	39.74
13	Probe #9	1275	37.37	35.33	39.11

3.2.4 Empty Unit Open Door Temperature Recovery (35°F Set Point)

With an average ambient temperature of 90.91°F, the test was conducted between 03:40pm EDT and 04:12pm EDT on 08/30/23. Temperature was logged at 1 minute intervals. After 25 minutes, only one temperature logger recorded temps outside of the allowable specification range. Testing protocol requires at least 50% of the loggers to go above the allowable specification range before termination, however the test was terminated after 25 minutes, as door openings of this length are well outside of the normal scope of use. The graphical and detailed report of internal and external data loggers is appended.



Title: Validation Summary Report for Walk-in Refrigerated Trailer Model PKM612

Manufacturer:	Polar King International, Inc.
Model Number:	PKM612
Equipment ID / Serial No:	A230712632

3.2.5 Empty Unit Power Failure Test (35°F Set Point)

With an average ambient temperature of 75.82°F, the test was conducted between 12:45pm EDT and 01:28pm EDT on 08/30/23. Temperature was logged at 1-minute intervals. The logged data showed the empty Refrigerated Trailer, with the power supply disconnected; the unit held temperature within the acceptable range for 37 minutes. With restored power, the unit stabilized within the acceptable range in approximately 6 minutes. The graphical report and data logs are appended.

3.2.6 24-HR Empty Unit Thermal Mapping (0°F Set Point)

At a set point of 0°F the Refrigerated Trailer was tested empty, with the door closed. Temperature data loggers were positioned as shown in figure 1. Temperature data was recorded for a 24 hour period, from 08:00am EDT on 08/19/23 to 08:00am EDT on 08/20/23. The data was logged at 1-minute intervals. Individual graph and data reports, as well as a summary data report have been included as appendices. The summarized data for all 13 temperature data loggers can be found in Table 3. No deviations were recorded during testing.

Average ambient temperature during the test was 71.13°F, with a max of 90.95°F and min of 55.85°F.

Table 3: Temperature Data Logger Locations and Labels

Data Logger Location	Data Logger Label	Data Logger Label (Alternate)	Avg. Temp (°F)	Min. Temp (°F)	Max. Temp (°F)
1	Probe #1	1171	3.14	0.86	6.71
2	Probe #10	1277	1.59	-1.75	5.36
3	Probe #11	1279	2.24	-0.76	6.08
4	Probe #12	1281	1.89	-1.21	5.54
5	Probe #13	1283	1.78	-1.57	5.54
6	Probe #2	1174	1.89	-1.30	5.63
7	Probe #3	1176	2.44	-0.22	5.81
8	Probe #4	1269	2.90	1.31	5.09
9	Probe #5	1178	3.47	1.85	6.71
10	Probe #6	1271	2.76	1.22	5.00
11	Probe #7	1273	2.87	0.68	6.08
12	Probe #8	1269	2.68	0.50	7.07
13	Probe #9	1275	2.41	0.05	5.36



Title: Validation Summary Report for Walk-in Refrigerated Trailer Model PKM612

Manufacturer:	Polar King International, Inc.
Model Number:	PKM612
Equipment ID / Serial No:	A230712632

3.2.7 Empty Unit Open Door Temperature Recovery (0°F Set Point)

With an average ambient temperature of 87.35°F, the test was conducted between 12:40pm EDT and 02:04pm EDT on 08/22/23. After 25 minutes, only three temperature loggers recorded temps outside of the allowable specification range. Testing protocol requires at least 50% of the loggers to go above the allowable specification range before termination, however the test was terminated after 25 minutes, as door openings of this length are well outside of the normal scope of use. The graphical and detailed report of internal and external data loggers is appended.

3.2.8 Empty Unit Power Failure Test (0°F Set Point)

With an average ambient temperature of 77.33°F, the test was conducted between 07:50am EDT and 10:56pm EDT on 08/21/23. Temperature was logged at 1-minute intervals. The logged data showed the empty Refrigerated Trailer, with the power supply disconnected; the unit held temperature within the acceptable range for approximately 2 hours and 6 minutes. With restored power, the unit stabilized within the acceptable range in approximately 5 minutes. The graphical report and data logs are appended.

3.3 Qualification Deviations

No deviations were found during testing.

4.0 CONCLUSION

Temperature validation of A230712632 was deemed successful, without any noted deviations.



Title: Validation Summary Report for Walk-in Refrigerated Trailer Model PKM612

Manufacturer:	Polar King International, Inc.
Model Number:	PKM612
Equipment ID / Serial No:	A230712632

5.0 Approvals

In review of the collected data for this Validation Summary Report, this study has been deemed successful. Any deviations are listed within the Validation Summary Report and are included as appendices.

Name: Max Tippmann

Signature: [Handwritten Signature]

Title: Engineer

Date: 9-12-23

Name: Todd Ellinger

Signature: [Handwritten Signature]

Title: V^o Business Admin

Date: 9-12-23



Title: Validation Summary Report for Walk-in Refrigerated Trailer Model PKM612

Manufacturer:	Polar King International, Inc.
Model Number:	PKM612
Equipment ID / Serial No:	A230712632

VAISALA

RFL100 Wireless Data Logger for continuous monitoring systems



Features
• Industry-leading measurement precision
• Interchangeable high-accuracy probes for T, RH, and CO ₂
• 30-day memory buffer
• Typical battery life of 18 months in RH and T measurement
• Uses standard alkaline batteries
• Probe calibrations are traceable to SI units through national metrology institutes or accredited calibration laboratories
• Cost-effective alternative to chart recorders

RFL100 Data Logger uses Vaisala’s proprietary VaiNet wireless technology. It can be used to monitor temperature (T), relative humidity (RH), and carbon dioxide level (CO₂) in a wide range of environments. Suitable applications include warehouses, production areas, cleanrooms, laboratories, incubators, fridges, cold storage areas, and freezers down to -196 °C (approx. -320 °F).

VaiNet wireless

RFL100 connects wirelessly to Vaisala viewLinc Monitoring System, which provides real-time trends, alarms, and historical reporting. VaiNet wireless technology is based on the LoRa® modulation technique to provide a robust wireless signal that is extremely reliable over long distances and in complex, obstructed conditions. This wireless technology allows the data logger’s signal to travel over 100 m (approx. 330 ft) indoors without the aid of signal amplifiers or repeaters. Wireless communications are encrypted to ensure data integrity and security.

Measurements are updated and stored every 60 seconds, and sent from the data logger every 4 minutes. In case of temporary network disruptions, the data logger can record up to 30 days of measurements that are automatically transmitted to the viewLinc Enterprise Server software when communications are restored. Recorded data can also be downloaded directly from RFL100 through the USB port.

Versatility and convenience

RFL100 requires no startup configuration, and the included mounting bracket supports several installation methods. Detailed custom display shows the latest measurement results, alarm and battery status, and signal strength of the current access point connection. The housing is classified IP54 to protect the device from dust and cleaning.

RFL100 is powered by two standard AA size 1.5V batteries (LR6 alkaline or FR6 lithium) for 18 months of operation at approximately 20 °C (68 °F) in RH and T measurement. When fresh batteries are inserted during yearly calibration, battery replacement between calibrations is not needed. External power is required for CO₂ measurement, with the batteries serving as backup in case the external power becomes unavailable.

Interchangeable probes

The probes are detachable and easy to switch out for calibration. viewLinc Enterprise Server detects the changed probe information automatically and maintains accurate and complete historical records.

RH and T probes use Vaisala HUMICAP® humidity sensors and platinum temperature sensors (Pt100 and Pt1000 type) for superior stability. Probes can be integrated with the RFL100 housing or connected using a cable.





CO₂ measurement is provided by the GMP251 probe that uses Vaisala’s patented, latest-generation CARBOCAP® technology with exceptional stability. The probe automatically compensates the CO₂ measurement according to ambient temperature.



Title: Validation Summary Report for Walk-in Refrigerated Trailer Model PKM612

Manufacturer:	Polar King International, Inc.
Model Number:	PKM612
Equipment ID / Serial No:	A230712632

Probe options

Probe	Description ¹⁾	Installation notes
<p>HMP110 and HMP110T</p> 	<p>Humidity and temperature probe for measurement in demanding conditions. Robust stainless steel construction. Temperature-only version HMP110T available.</p> <p>Plastic grid filter provides the fastest responsetime. For added protection, select the membranefilter, the PTFEfilter, or the stainless steel sintered filter.</p> <p>Measurement temperature range -40 ...+80 °C (-40 ...+176°F).</p>	<p>Suitable for measurement inside chambers, incubators, fridges, and freezers.</p> <p>Versatile mounting options using accessories.</p> <p>Must be connected to RFL100 using a cable.</p>
<p>HMP115 and HMP115T</p> 	<p>Humidity and temperature probe for general purpose measurement. Temperature-only version HMP115T available.</p> <p>Plastic grid filter provides the fastest responsetime. For added protection, select the membranefilter or the PTFEfilter.</p> <p>Measurement temperature range -40 ...+60 °C (-40 ...+140°F).</p>	<p>Ideal choice for ambient measurement.</p> <p>Can be integrated with the RFL100 housing or connected using a cable.</p>
<p>TMP115</p> 	<p>Temperature probe for measurement in a wide range of conditions.</p> <p>Available as 50 cm (1ft 7.7in) and 3m (9.8 ft) long versions. Length includes the probe body and sensor tip.</p> <p>Measurement temperature range -196 ...+90 °C (-320 ...+194°F).</p> <p>Operating temperature range of the probe body is -40 ...+60 °C (-40 ...+140°F).</p>	<p>Suitable for measurement inside chambers, fridges, and freezers.</p> <p>Can be integrated with the RFL100 housing or connected using a cable.</p> <p>Sensortip withstands immersion in glycol and liquid nitrogen.</p> <p>Use the thermal dampener block accessory (item code 236310SP) to add thermal mass to the sensor tip.</p>
<p>GMP251</p> 	<p>Carbon dioxide probe for %-level measurements. Designed for use in demanding applications such as life science incubators.</p> <p>Measurement temperature range -40 ...+60 °C (-40 ...+140°F).</p> <p>When ordered with the RFL100 data logger, the probe is delivered with a mounting kit that includes a probe holder designed for use with GMP251 and the other supported probes. The kit also includes a magnetic holder for the Probe Splitter M8/M12 accessory.</p>	<p>Must be connected using the Probe Splitter M8/M12 accessory. Any one of the other supported probes can be connected at the same time in the M8 connector of the probe splitter.</p> <p>Requires use of external power supply due to power consumption. Data logger batteries provide a backup in case the external power is not available.</p> <p>Logged temperature data is limited to range -40 ...+60 °C (-40 ...+140°F) when GMP251 is connected.</p>

1) See probe datasheets for detailed probe specifications.



Title: Validation Summary Report for Walk-in Refrigerated Trailer Model PKM612

Manufacturer:	Polar King International, Inc.
Model Number:	PKM612
Equipment ID / Serial No:	A230712632

Accessories

Accessories

Accessory ¹⁾	Item code
Probe cable for RFL100, 1.5m	CBL210555-1M5SP
Probe cable for RFL100, 3 m	CBL210555-3MSP
Probe cable for RFL100, 10 m	CBL210555-10MSP
Flat cable for RFL100, 3 m	CBL210647SP
Probe holder (5 pcs) for Ø 12mm probes	ASM213382SP
CO ₂ probe mounting kit	ASM214253SP
Probe splitter M8 (for connecting two T probes)	CBL210834SP
Probe splitter M8/M12(for connecting a CO ₂ probe)	CBL211050SP
1m high-temperature cable M12(for CO ₂ probe) ²⁾	271038SP
1m high-temperature cable M8(for RH/T probe in CO ₂ applications) ²⁾	271039SP
Universal power supply (100–240 V AC/ 5 V DC)with micro-USB connector	ASM214178SP

1) See probe datasheets for probe-specific accessories.

2) High-temperature cables are extensions for the probe splitter M8/M12 in CO₂ applications. They tolerate -20 ... +180 °C (-4 ... +356 °F) temperatures and can remain inside an incubator during a typical heat sterilization cycle. Due to heat conduction, leave half of the cable in ambient temperature when installed.

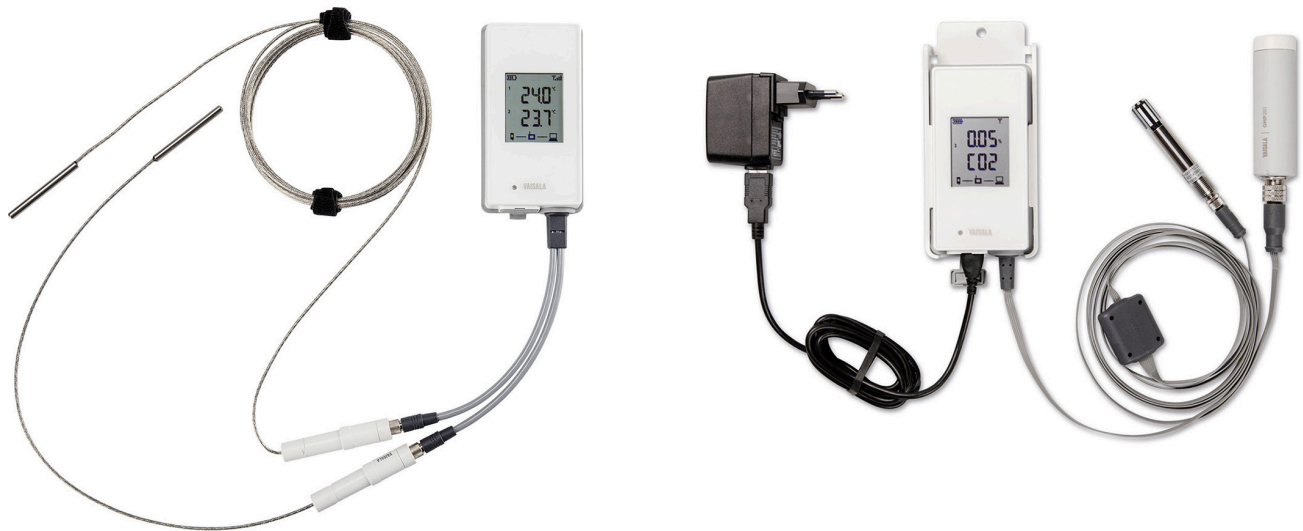

RFL100 with two TMP115 probes (left) and with GMP251 and HMP110 probes (right)



Title: Validation Summary Report for Walk-in Refrigerated Trailer Model PKM612

Manufacturer:	Polar King International, Inc.
Model Number:	PKM612
Equipment ID / Serial No:	A230712632

Technical data

Wireless

Networking standards	Vaisala VaiNet
Modulation	LoRa™ chirp spread spectrum modulation
Output power	13dBm (20 mW)
Antenna	Internal
Typical range (indoors)	At least 100 m (approx. 330 ft)
Range with line-of-sight	Over 500 m (1640ft)
Frequency bands	868 MHz, 915MHz, 920 MHz, and 922 MHz

Memory

Sample capacity	30 days (43200 samples per channel)
Memory type	Non-volatile EEPROM
Memory mode	Ring buffer (FIFO)
Sampling rate	One sample / channel / minute (non-changeable)

General

Compatible probes	GMP251, HMP110, HMP110T, HMP115, HMP115T, TMP115
Batteries	2 × AA sized, 1.5V (LR6 or FR6)
Operation time on battery power at 20 °C (68 °F)	
RH and T measurement in any probe combination	18 months
CO ₂ measurement	Typically 12 hours with lithium batteries

Compatibility requirements

Item	Required minimum version(s)
viewLinc version	viewLinc Enterprise Server 5.0
Dual T probe support using Probe Splitter M8 accessory	<ul style="list-style-type: none"> RFL100 firmware 1.2.0 AP10 firmware 3.0 viewLinc Enterprise Server 5.0.2
CO ₂ measurement using Probe Splitter M8/M12 accessory and external power	<ul style="list-style-type: none"> RFL100 firmware 1.4.0 RFL100 hardware manufactured after July 2021 AP10 firmware 4.0 and hardware revision G viewLinc Enterprise Server 5.1

Operating environment

Storage temperature	-40 ... +60 °C (-40 ... +140 °F)
Operating humidity	0 ... 100 %RH, non-condensing
IP rating	IP54
IP rating with external power supply	IP20
Operating temperature ¹⁾	
with alkaline batteries	+2 ... +60 °C (+35.6 ... +140 °F)
with lithium batteries	-20 ... +60 °C (-4 ... +140 °F)
with external power supply	0 ... +60 °C (+32 ... +140 °F)

1) Verify operating temperature specification when using third party batteries and power supplies.

Compliance

EMC compatibility	IEC/EN 61326-1, industrial environment
Electrical safety	IEC/EN 61010-1
868 MHz model	
EU directives and regulations	RoHS Directive (2011/65/EU) amended by 2015/863 Radio Equipment Directive, RED (2014/53/EU)
Radio standards and approvals	ETSI EN 300 220-2 ETSI EN 301489-1 ICASA No: TA 2020-7761 IMDA No: DB105576 TRA No: 67584/18 Serbia: U005 21
Compliance marks	AAA, CE, UKCA
915 MHz model	
Radio standards and approvals	Anatel ID: 04761-19-12322 AS/NZS 4268 FCC ID: 2A039-RFL100A IC ID: 23830-RFL100A NOM ID: 1901C00493
Compliance marks	ANATEL, China RoHS, NOM, NYCE, RCM
920 MHz model	
Radio standards and approvals	MIC ID: 012-200007
Compliance marks	GITEKI
922 MHz model	
Radio standards and approvals	NCC ID: CCAP21LP1240T3
Compliance marks	NCC



Title: Validation Summary Report for Walk-in Refrigerated Trailer Model PKM612

Manufacturer:	Polar King International, Inc.
Model Number:	PKM612
Equipment ID / Serial No:	A230712632

Mechanical specifications

Housing color	White
Mounting methods	Screws, cable ties, hook, or magnetic mounting bracket (optional accessory)

Probe interface	4-pin female M8 connector
Service port	USB2.0 with micro-USB connector

Dimensions (H x W x D) with HMP115 probe

Without mounting bracket	158 x 62 x 31mm (6.22 x 2.4 x 1.22in)
With mounting bracket	186 x 68 x 36.5 mm (7.32 x 2.68 x 1.44in)

Weight

With batteries (2 pcs alkaline) and HMP115 probe	190g (6.7 oz)
With batteries (2 pcs alkaline), HMP115 probe, and magnetic mounting bracket	254 g (8.96 oz)

Materials

Housing	PC/ABS blend
Display window	PMMA (acrylic)
Sealings	TPE

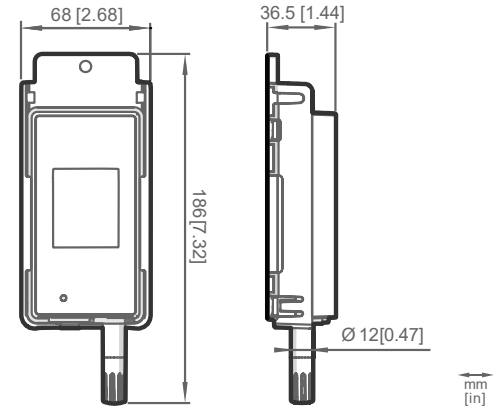

RFL100 dimensions with HMP115 probe

Requirements for external power supply

Output voltage	5 V DC
Output power	Min. 1W
Output connector	Micro-USB
Certifications and approvals	<ul style="list-style-type: none"> • Certified to IEC62368-1 • Approved for use in your country



www.vaisala.com

Published by Vaisala | B211595EN-M© Vaisala 2022

All rights reserved. Any logos and/or product names are trademarks of Vaisala or its individual partners. Any reproduction, transfer, distribution or storage of information contained in this document is strictly prohibited. All specifications — technical included — are subject to change without notice.



Title: Validation Summary Report for Walk-in Refrigerated Trailer Model PKM612

Manufacturer:	Polar King International, Inc.
Model Number:	PKM612
Equipment ID / Serial No:	A230712632

<p>ROOM TEMP.: 0F to 50F INTERIOR VOLUME: 416 CU. FT. HORSEPOWER: 3/4 HP REFRIGERANT: R-452A ELEC. SUPPLY: 115V PHASE: Single CYCLE: 60 Hz. AMPERAGE: 15.0 MCA R-VALUE: R-28</p>	<p>INTERIOR DIMENSIONS: 11'-2 3/4" x 5'-8 3/4" x 6'-5 3/4" DOOR CLEAR OPENING: 50 1/2" x 69"</p>	<p>GOVI ARKTIK 2000US - THERMOMETER - LIGHT SWITCH 4" WALLS & ROOF HEAVY DUTY FLOOR STRIP CURTAINS LED LIGHTING 7 BLADE CONNECTOR 2 5/16" COUPLER E-TRACK READY GVWR: 7,000 LBS. TRAILER: 2,700 LBS. CAPACITY: 4,300 LBS.</p>
<p>Polar King Mobile 2022</p>		
<p>DRAWN BY: MJR MODEL NO.: PKM612 DRAWING NAME: PKM 2D 2022</p>	<p>SCALE: 3/16" = 1' DATE: 1/5/22</p>	