

2



1

B

B

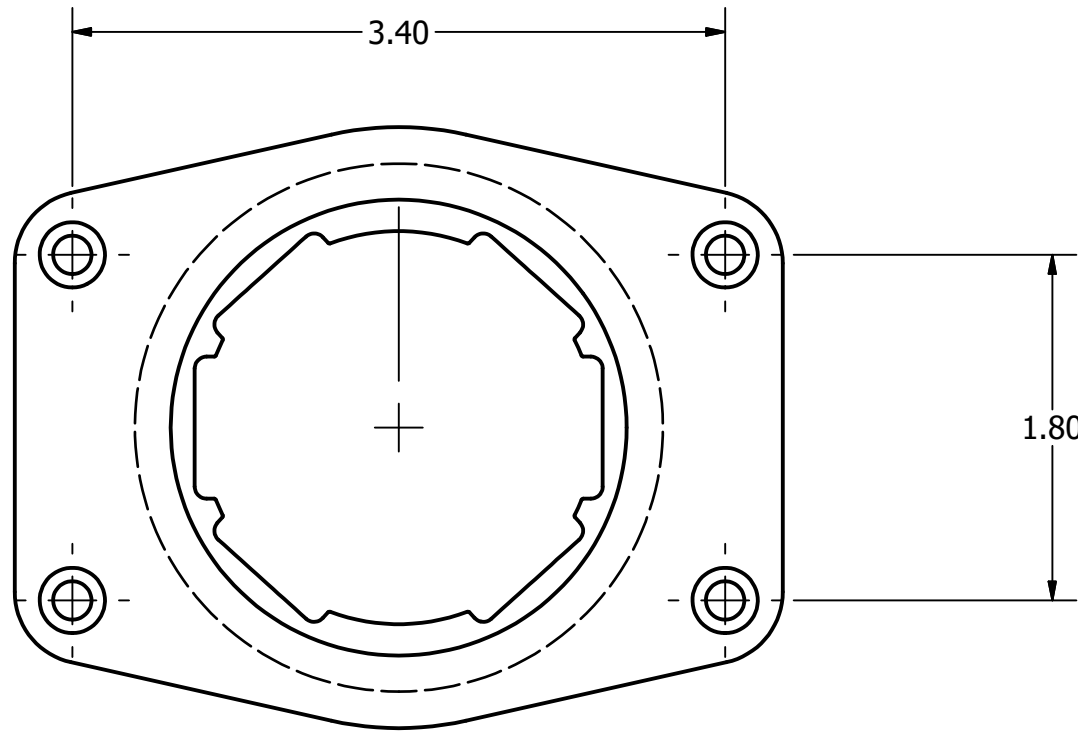

A

A

STEP #1 - CENTER PUNCH ALL OF THE HOLE CENTERLINES.

STEP #2 - DRILL 4 MOUNTING HOLES W/ A 13/64" DRILL BIT.

STEP #3 - DRILL LARGE CENTER HOLE W/ A 2-1/2" HOLE SAW.



TITLE:
RWS_PANEL_TURNS_v3

PROPRIETARY AND CONFIDENTIAL
THE INFORMATION CONTAINED IN THIS DRAWING IS THE SOLE PROPERTY OF RACEWIRE SOLUTIONS LLC. ANY REPRODUCTION IN PART, OR AS A WHOLE WITHOUT THE WRITTEN PERMISSION OF RACEWIRE SOLUTIONS LLC IS PROHIBITED.

DWG NO. RWS_PANEL_TURNS_v3_template.dwg	REV 0
---	----------

DWG BY: DWO	DATE: 5/28/2020
-------------	-----------------

SHEET A	SCALE 1 : 1	SHEET NO: 1 OF 1
------------	----------------	------------------

2



1