



A COMPLETE MATERIAL HANDLING SOLUTION



We help you handle your material

www.storeedgeindia.com

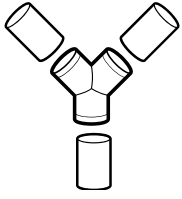

1 - THE MODULAR FACTOR

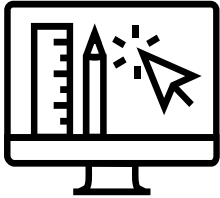

2 – THE CUSTOMIZATION FACTOR

TPS

3 – THE LEAN FACTOR



4 – THE ECONOMIC FACTOR

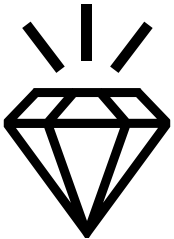

5 – THE ASTHETICS FACTOR

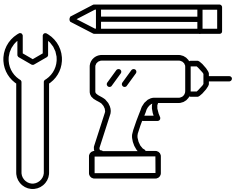

6 – THE SIMPLICITY FACTOR



7 – THE LIGHT AND LINEAR FACTOR

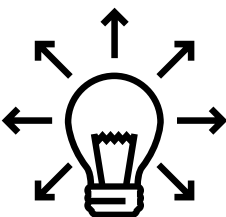

8 – THE VERSATILITY FACTOR

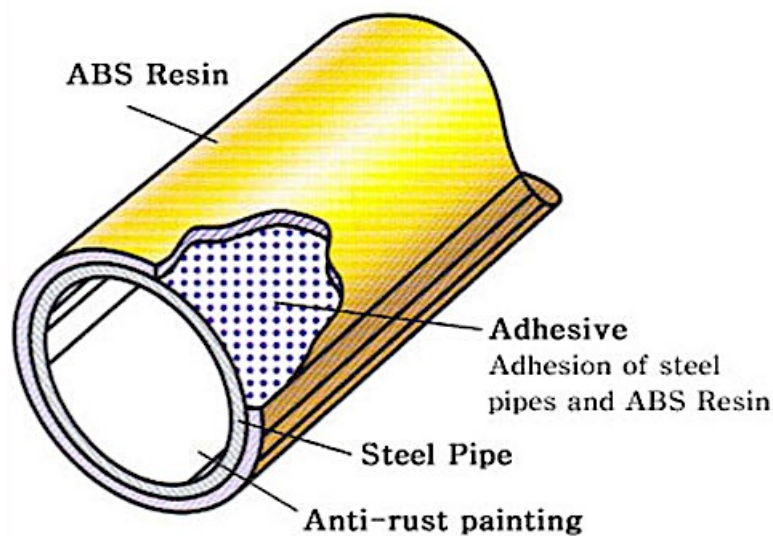

The pipe is a steel pipe coated with ABS Resin on the outer surface. An adhesive bond's the resin to the pipe preventing separation. The inner surface is non – corrosive. The pipe has excellent durability, chemical resistance, impact resistance, solid and light.

Space Management System for

- Warehouse
- Shop Floor
- Logistics
- Office
- Industry
- Showroom

Applications

- FIFO Rack
- Gravity Conveyor
- Storage Rack
- Sliding Rack
- Roller Conveyor
- Trolley, Cart

PIPES

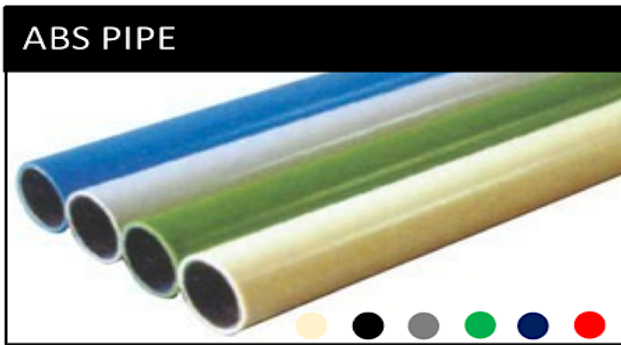

Product Code	Thickness (STEEL)	WEIGHT
ABS - 1100	1 t	676 g/m
ABS - 1200	2 t	1265 g/m



Product Code	Thickness (STEEL)	WEIGHT
ST - 1070	0.8 t	473 g/m
ST - 1110	1.1 t	734 g/m



Product Code	Thickness (STEEL)	WEIGHT
AL - 1150	1.2 t	330 g/m



Product Code	Thickness (STEEL)	WEIGHT
SL - 1100	1 t	767 g/m



Product Code	Thickness (STEEL)	WEIGHT
PD - 1080	1 t	540 g/m



Product Code	Thickness (STEEL)	WEIGHT
CP-1100BK	1t	676g/m

METAL JOINTS

HJ-1

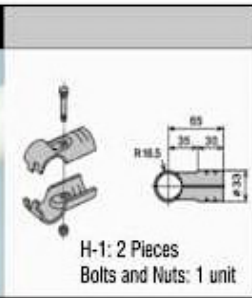
H-1: 2 Pieces
Bolts and Nuts: 1 unit

HJ-2

H-2: 1 Pieces
H-3: 1 Pieces
Bolts and Nuts: 2 unit

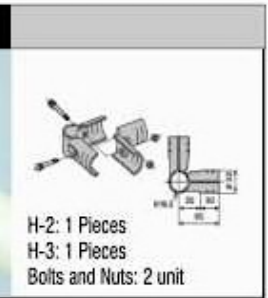
HJ-3

H-2: 2 Pieces
H-4: 1 Pieces
Bolts and Nuts: 3 unit

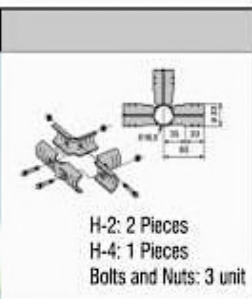
HJ-4

H-4: 2 Pieces
Bolts and Nuts: 2 unit

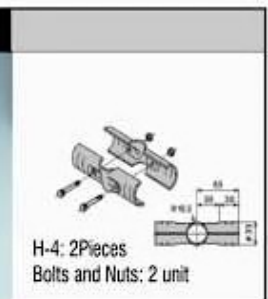
HJ-5

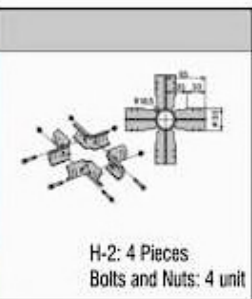

H-2: 4 Pieces
Bolts and Nuts: 4 unit

HJ-6

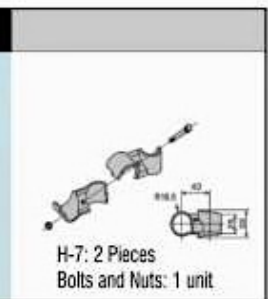
H-7: 2 Pieces
Bolts and Nuts: 1 unit

HJ-7



H-5: 2 Pieces
H-6: 2 Pieces
Bolts and Nuts: 2 unit

HJ-8





H-8: 2 Pieces
H-6: 4 Pieces
Bolts and Nuts: 4 unit

HJ-9

H-9: 2 Pieces
Bolts and Nuts: 1 unit

HJ-10

H-10: 2 Pieces
Bolts and Nuts: 1 unit

PLACONS

PLACON 40 SERIES

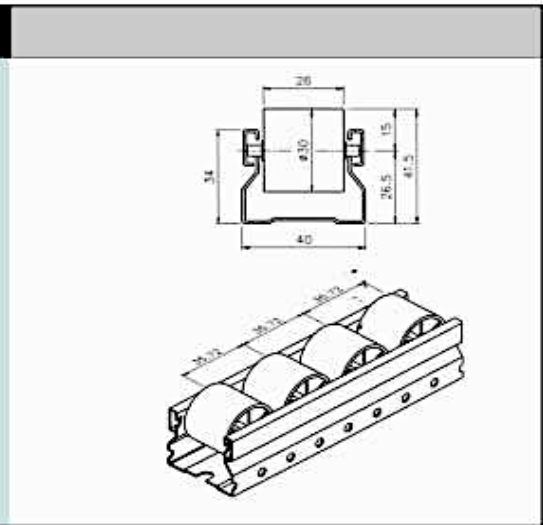
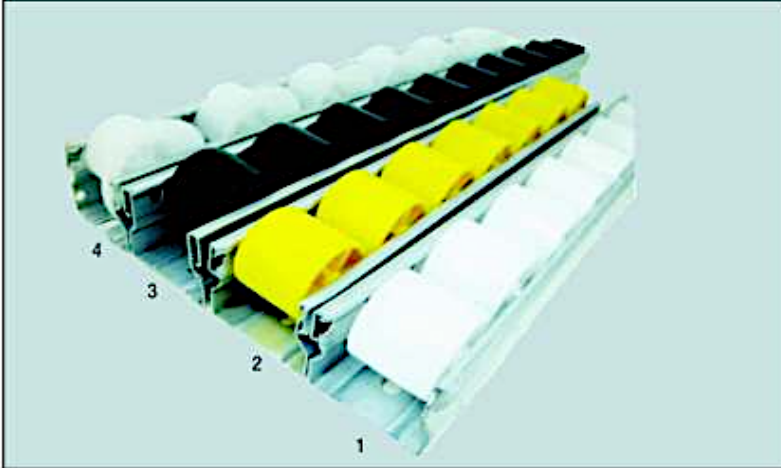

PLACON 60 SERIES

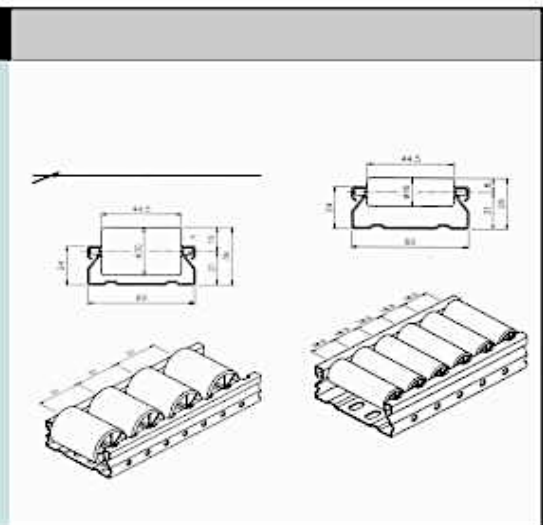
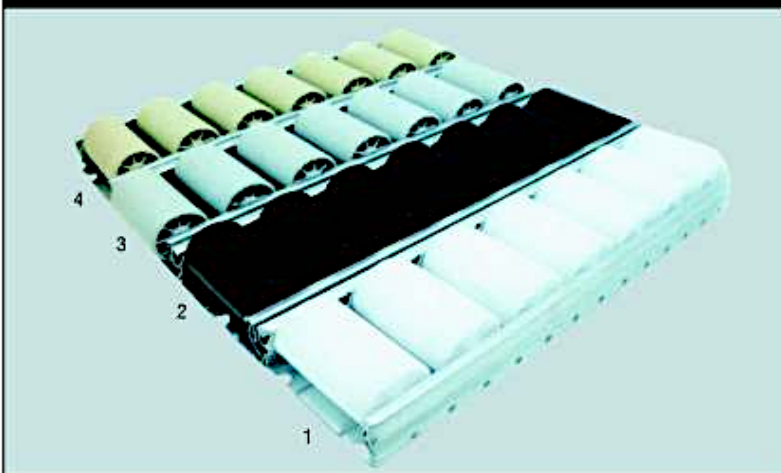

PLACON 73 SERIES (ALUMINIUM)

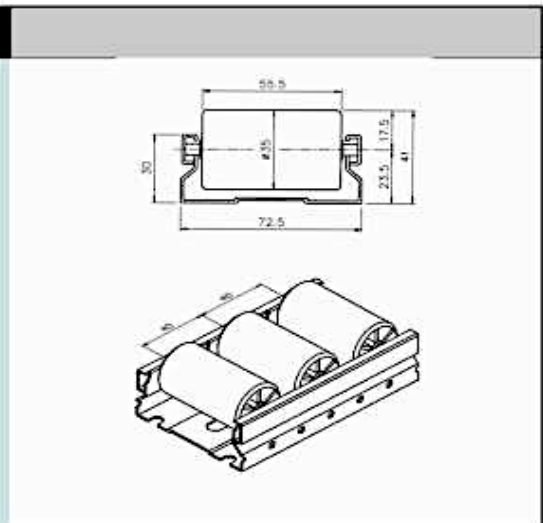

TECHNICAL DATA

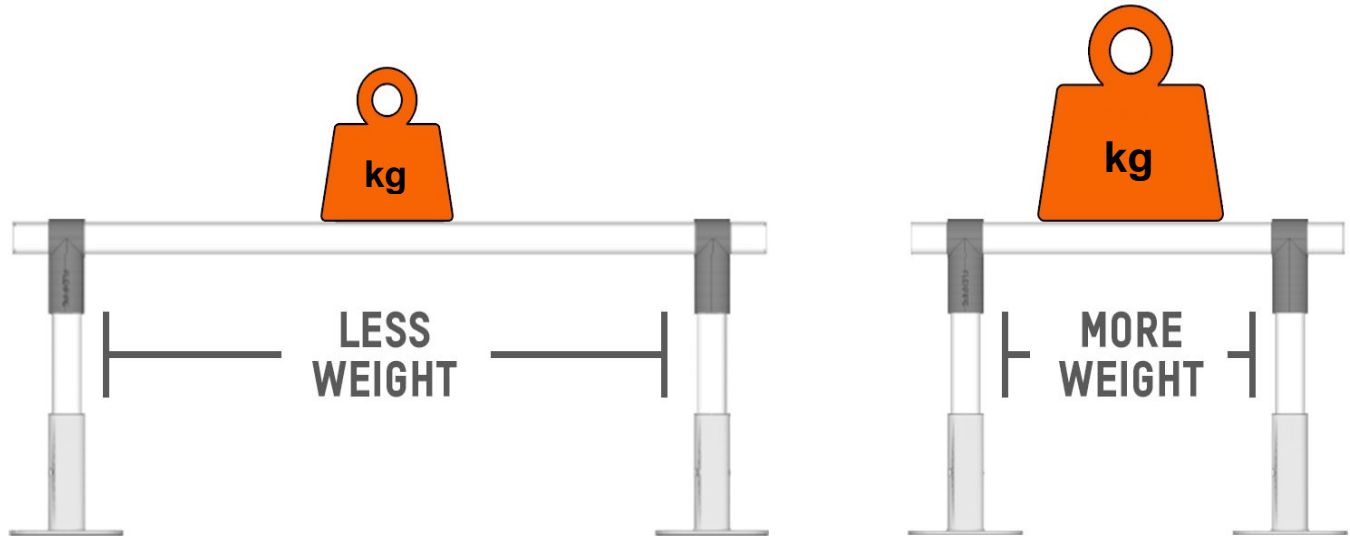

PIPE SPAN	ABS 1	ABS 2
1.00 m	68 kg	150 kg
1.25 m	55 kg	123 kg
1.50 m	46 kg	100 kg
1.75 m	39 kg	88 kg
2.00 m	34 kg	75 kg
2.25 m	30 kg	68 kg
2.50 m	27 kg	62 kg

SPARE PARTS

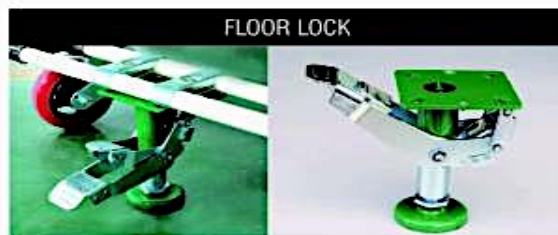
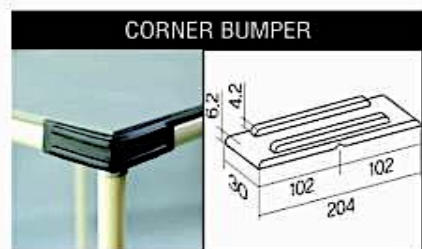
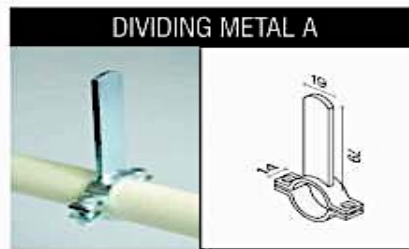
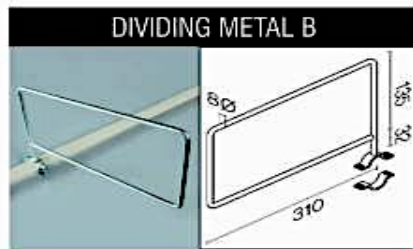
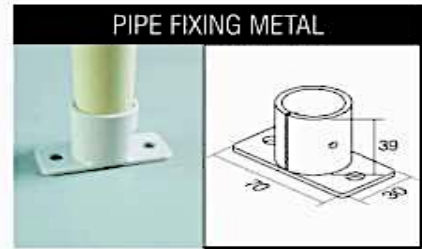
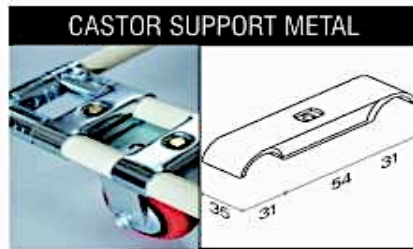

Boards & Sheets



Rack Design



Textile



Maintainace



Aerospace



Electronics



Hardware Shelf



Metal Sheet Storage

Flow Structure Design



Assembly FIFO table

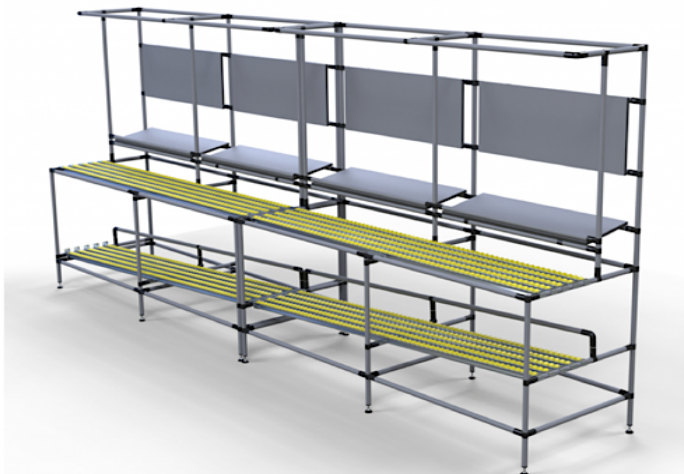

Continuous Inspection table

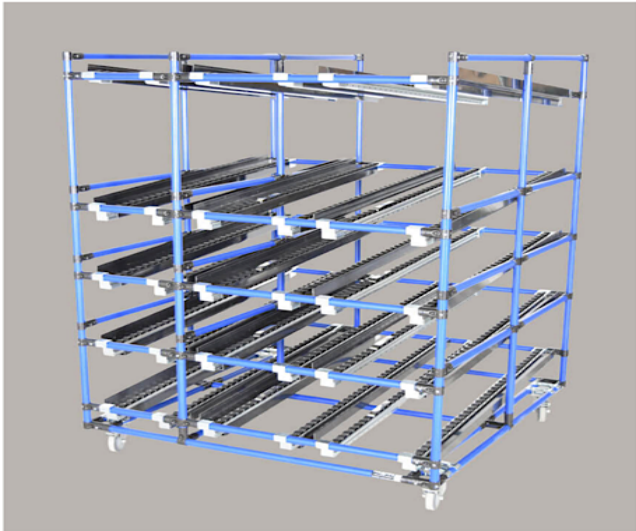

Supermarket

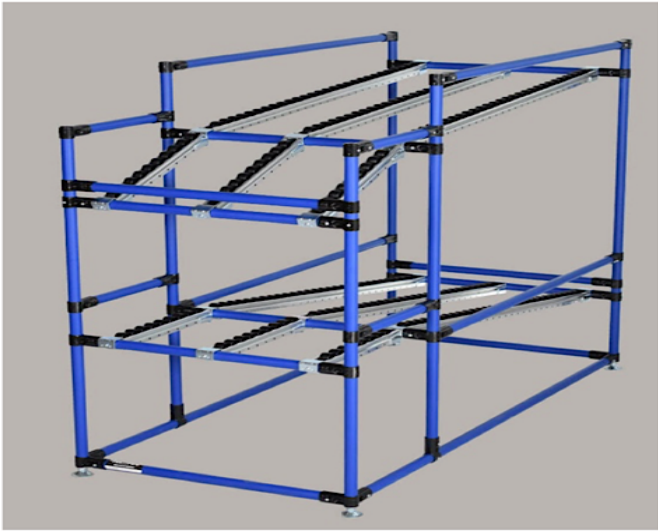

FIFO with return

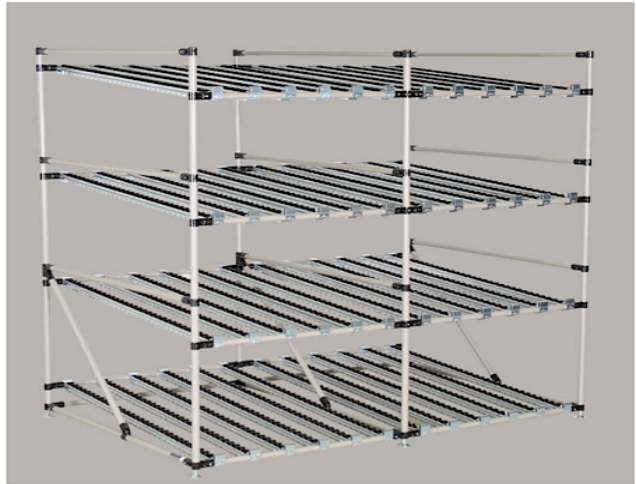

Store



L-shaped Gravity

Trolley Design



Bin Trolley

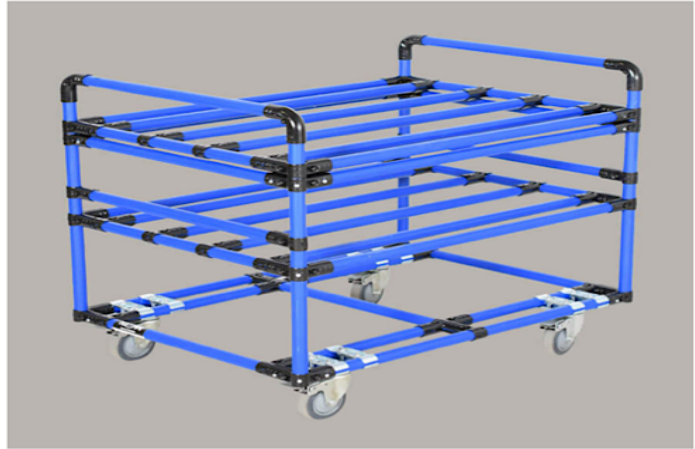

Container Transport



Storage Trolley



Assembly Trolley

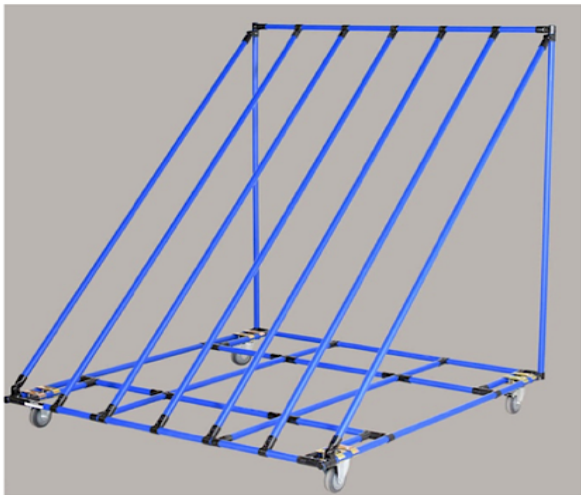

Ply Trolley



Hospital Trolley

Workstation Design



FIFO Assembly Station



Drawer Bench

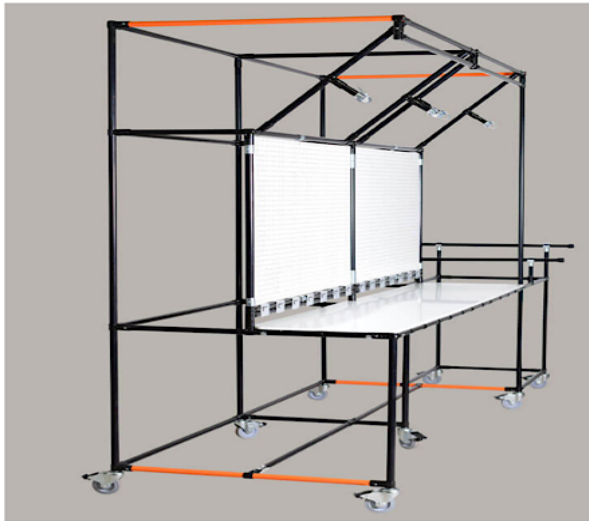

Packaging Station 1

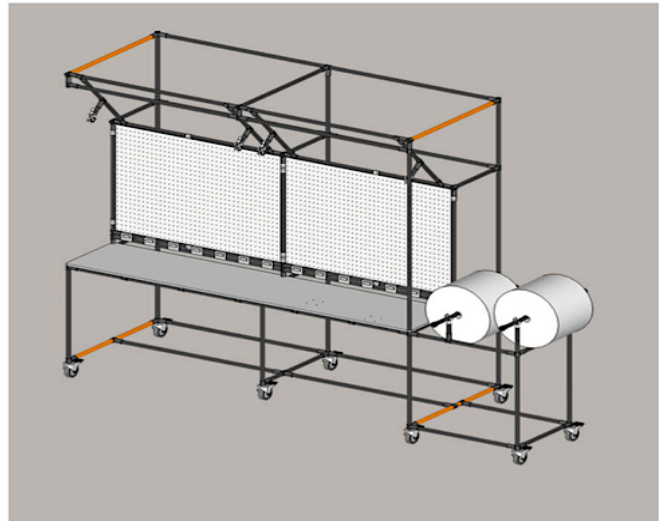

Packaging Station 2



Pipe Cutting Station



Packaging Station 3

PIPE & JOINT APPLICATIONS

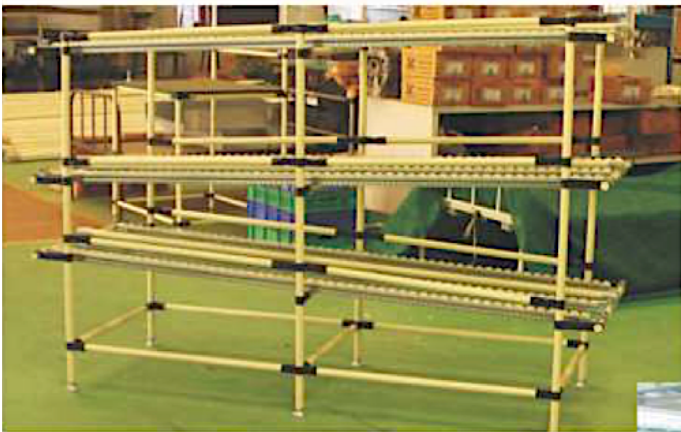

VARIOUS STRUCTURES



PACKAGE TRAY SEQUENCE CART



ELECTRONIC PRODUCT MOVING CART



ELECTRONIC PART SUPPLYING CART



ELECTRONIC PART SUPPLYING CART



SUN VISAR SEQUENCE CART



TROLEYS



IDENTIFICATION SYSTEM RACK

TROLLY



WORK STATION

VARIOUS STRUCTURES



PARTS SUPPLYING RACK FOR AUTOMOBILE ENGINE



STORAGE RACK



ELECTRONIC PART BULK CARRIER



MAIN ASSEMBLY LINE RACK FOR AUTOMOBILE



ROOF RACK SEQUENCE CART



BOOK SHELF



IDENTIFICATION SYSTEM RACK



STORAGE RACK



storedge industries

G – 56, VIP PLAZA, VIP ROAD, VESU,
SURAT – 395007, GUJARAT, INDIA

Contact: [Rajat Paliwal](#)

Phone: [+91 9825151026](#)

Email: rajat@storedgeindia.com

C/o *Sankalp Dyeing & Printing Mills Pvt. Ltd.*

PLOT #268, ROAD #2, GIDC, SACHIN,
SURAT – 394230, GUJARAT, INDIA