

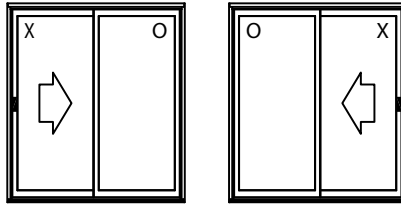

**Series 7700 & 5400 Vinyl Sliding Patio Door**  
**XO, OX, XOO, OOX, OXO, and OXXO**  
ASSEMBLY & INSTALLATION GUIDE

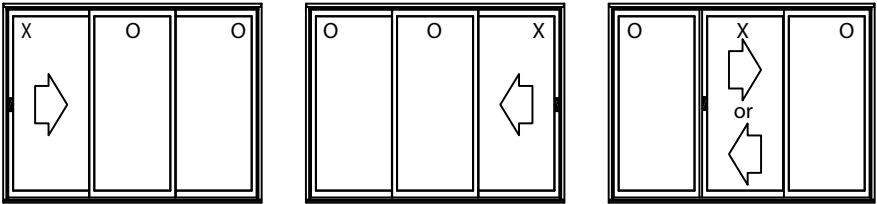

**TWO PANEL DOORS**  
(Pre-Assembled Doors Standard, KD Optional)



**THREE PANEL DOORS (Series 7700 Only)**  
(KD Door Standard Pre-Assembled Doors Optional)

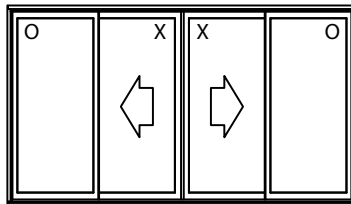

**FOUR PANEL DOORS (Series 7700 Only)**  
(KD Door Only)



*The way it should be.*

Scan QR code for  
detailed installation  
instructions.





## Series 7700 & 5400 Vinyl Sliding Patio Door XO, OX, XOO, OOX, OXO, and OXXO ASSEMBLY & INSTALLATION GUIDE

### Important

This document describes procedures, step by step, for all patio door manufacturing. All fabrication procedures that are different from those mentioned in this document may alter performances and/or the quality of finished product.

Contents	
Required Screws	1
Frame Assembly	2
Sill Assembly	3
Preparing the Opening	4
Frame Installation	5-6
Handle and Mortise Lock Installation	7
Preparing the Mainframe	8
Fixed Panel Installation	9-10
Operating Panel Installation	11
Screen Installation	12
Head Weatherseal and Insect Stop Installation	13
Keeper and Sash Stopper Installation	14
Mullion Anchor Block Installation for Three (3) Panel Doors	15
Mullion Assembly for Three (3) Panel Doors	16
Final Mullion Assembly for Three (3) Panel Doors	17
Mullion Assembly for Four (4) Panel Doors	18
Screen Mullion Assembly for Four (4) Panel Doors	19
Secondary Lock and Keeper Installation	20

## Required Screws



#4 x 3/8" Pan Head Screw  
(For Screen Keeper in a Three (3) Panel Door Only)



#6 x 5/8" Pan Head Screw  
(For Screen Keeper and Screen Stopper in a Four (4) Panel Door)



#10 x 5/8" Flat Head Screw  
(For Metal Anchor and Foot Bolt)



#8 x 7/8" Pan Head Screw  
(For Fixed Panel)



#8 x 1" Flat Head Shutter Screw  
(For Mullion and Screen Mullion in a Three (3) Panel Door)



#8 x 1" Pan Head Screw  
(For Three (3) Panel Door Mullion and Foot Bolt Keeper)



#8 x 1-1/4" Black Pan Head Screw  
(For Head Weatherseal and Sash Stopper)



#8 x 1-1/4" Pan Head Screw  
(For Keeper)



#8 x 1-3/4" Pan Head Screw  
(For Mullion in a Four (4) Panel Door)



#8 x 1-3/4" Flat Head Shutter Screw  
(For Sash Stopper in a Four (4) Panel Door)



#8 x 2" Pan Head Screw  
(For Screen Mullion in a Four (4) Panel Door)



#8 x 2" Truss Head Screw  
(For Frame Assembly)



#10 x 2-1/2" Flat Head Screw  
(For Mortise Lock)

# 1

## Step 1 Frame Assembly

(For Pre-assembled Doors, Go to Step 3)

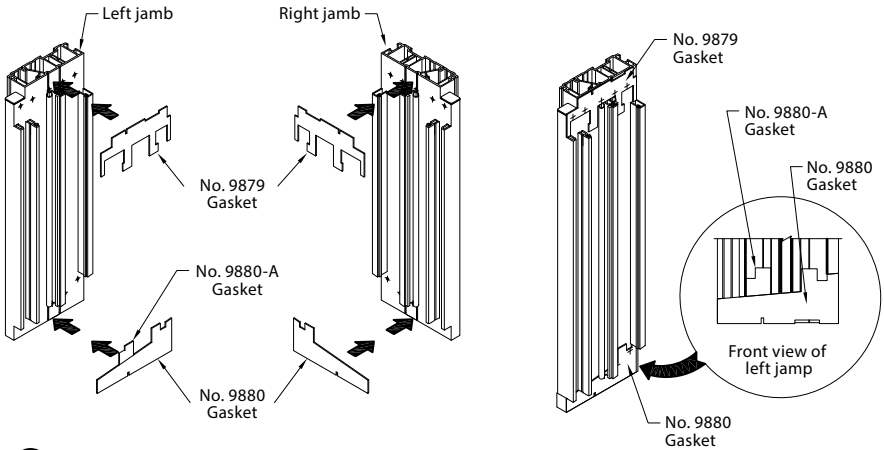

- A** Peel and stick corner gaskets No. 9879 to the head on each jamb. Peel and stick No. 9880 corner gaskets to the sill on each jamb, starting from the inside in order to be able to fold them back in front of the jambs. Peel and stick gasket No. 9880-A on left jamb for an OX door, or on right jamb for an XO door.

- B** Make sure corner gaskets make a perfect joint with head and sill.

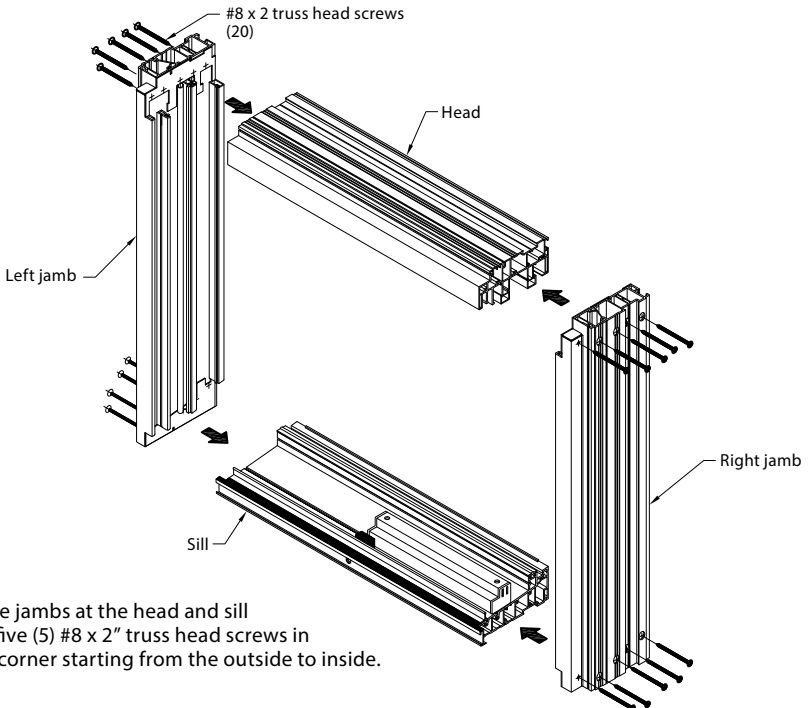

- C** Fix the jambs at the head and sill with five (5) #8 x 2" truss head screws in each corner starting from the outside to inside.

## Step 2 Sill Assembly

2

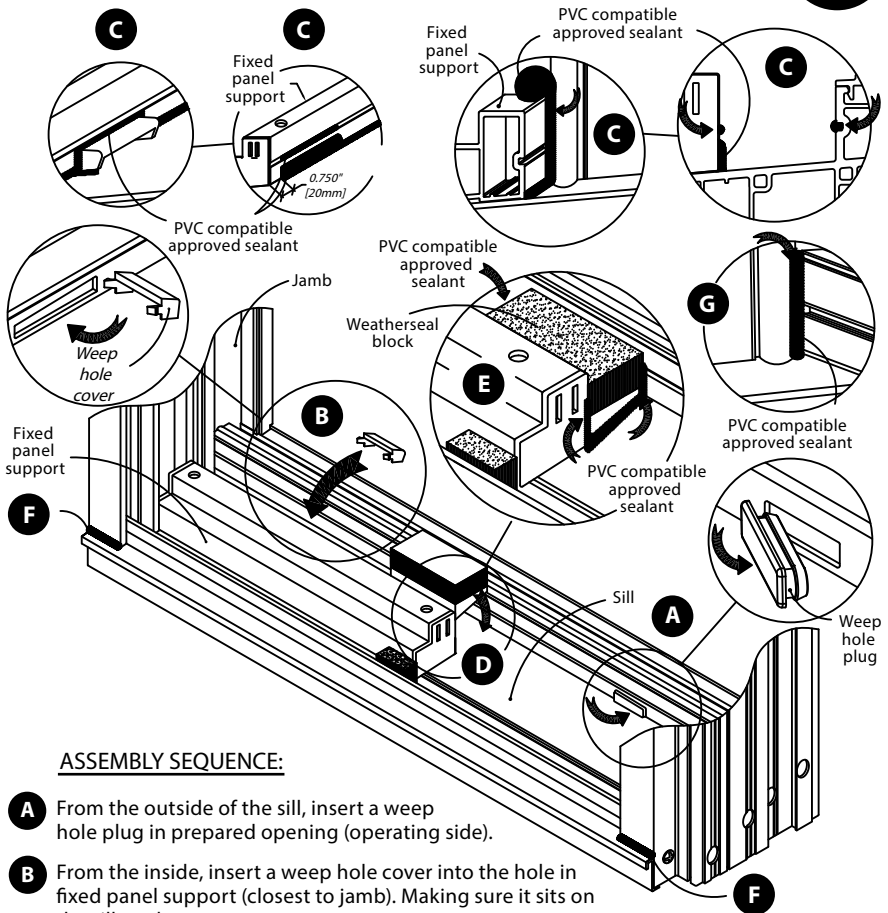

### ASSEMBLY SEQUENCE:

- A** From the outside of the sill, insert a weep hole plug in prepared opening (operating side).
- B** From the inside, insert a weep hole cover into the hole in fixed panel support (closest to jamb). Making sure it sits on the sill track.
- C** From the inside, caulk the top and sides of the weep hole cover and caulk all along the fixed panel support with a sealant that is approved and compatible with PVC. On the side of the fixed panel support where there is no weep hole cover, apply more caulking in order to seal the unused drain hole and space between the fixed panel support and the weatherseal block. Also caulk the grooves on each side of the weatherseal block as illustrated above. Apply a thin amount of sealant at the corner where the fixed panel support and bulb seal of jamb meet. Finish on top of the fixed panel support with a ball of sealant.
- D** Peel and stick the sill weatherseal block at 1/32" [1 mm] from the end of the fixed panel support or at 1/8" [3 mm] from the end of the black cap located at the end of the fixed panel support.
- E** Caulk both ends of weatherseal block as illustrated above.
- F** On the outside face of the sill, at the jamb, apply a sealant that is approved and compatible with PVC.
- G** On the operating sash side, in the space between the bulb seal and the sill, apply a thin amount of sealant.

# 3

## Step 3 Preparing the Opening

Read instructions and review anchorage details carefully before starting installation and make sure the new door will fit into the opening (allow 1/2" or 3/4" gap all around). Anchorage details are available at [wincorewindows.com](http://wincorewindows.com) and by scanning the QR Code on the front cover of this installation guide.

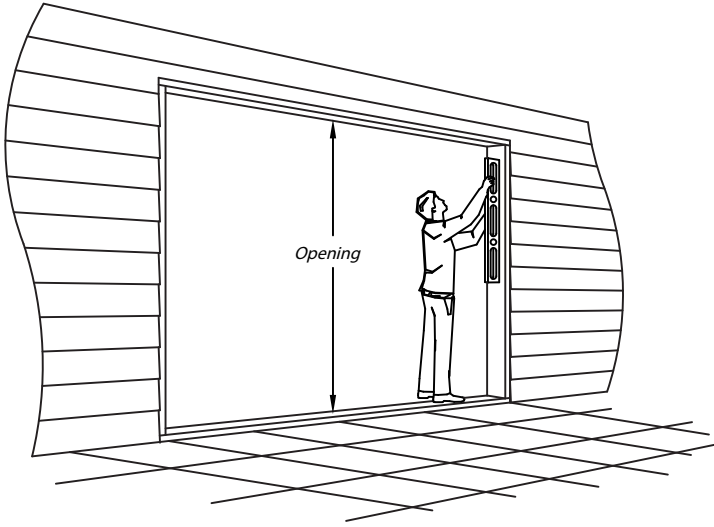

The performance of this door will be affected if the opening is too small or too large. A level sill is critical. If necessary, use wooden shims (one at the center and one at each end) to ensure a level surface prior to installing the door.

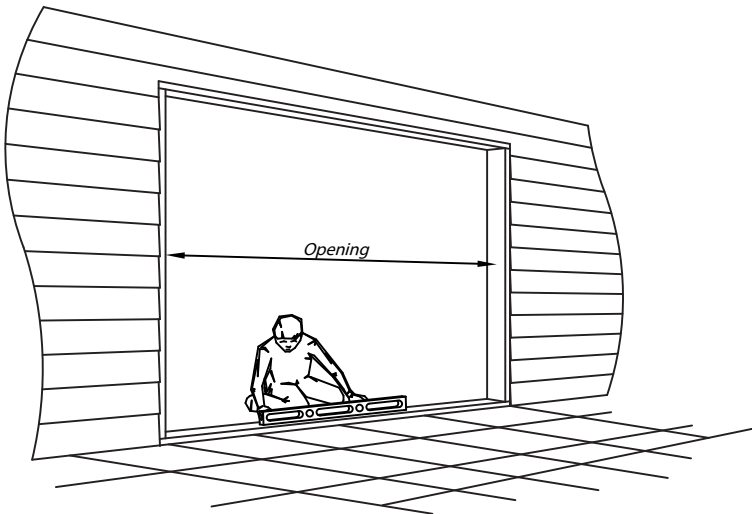

## Step 4 Frame Installation

4

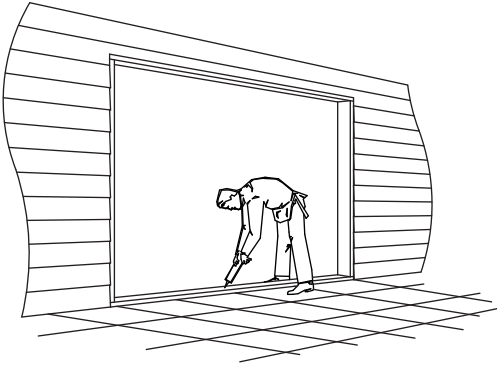

Install a bead of premium caulking compound along the entire length of the sill.

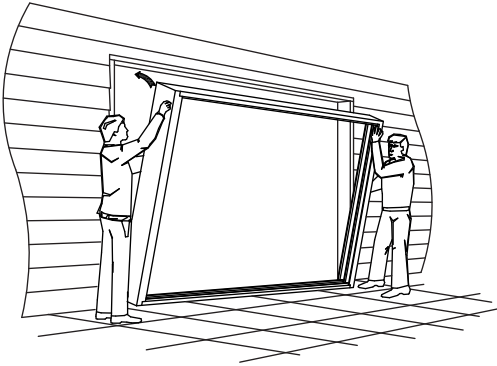

Sit the door unit in the opening, sill first. Make sure caulking compound makes a perfect seal between the door sill and the floor.

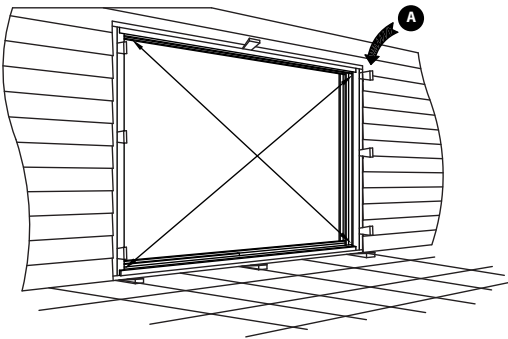

Shim the door as shown above. Once the door is centered in the opening, place a shim at the top of the fixed panel jamb (A) and secure with a screw through the jamb next to the shim. Measure the diagonals to ensure the door frame is square. Complete shimming of fixed panel jamb, then operating panel jamb and finally the head and sill. **NOTE:** Do not over-shim as it will cause the unit to bend and jeopardize the performance of the door.

# 5

## Step 5 Frame Installation (Continued)

Using a special step drill, drill the installation holes next the the shim. Screw with #8 x 3" screw and cover with plastic screw cap. Measure the diagonals to ensure the door frame is square. Complete shimming of fixed panel jamb, then operating panel jamb and finally the head. In order to prevent any water infiltration, screwing through the sill is not recommended. Caulk and finish the exterior of the door to ensure water tightness between the rough opening and door frame. Finish interior of the door.

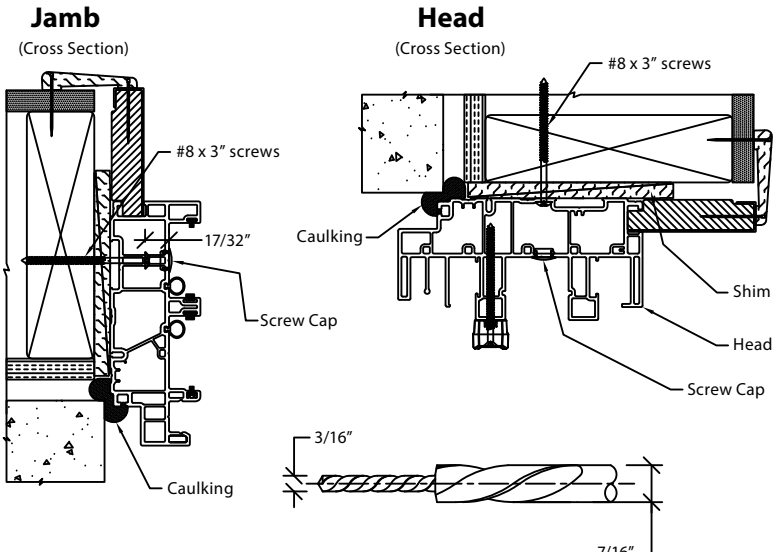



## Step 6 Handle and Mortise Lock Installation

6

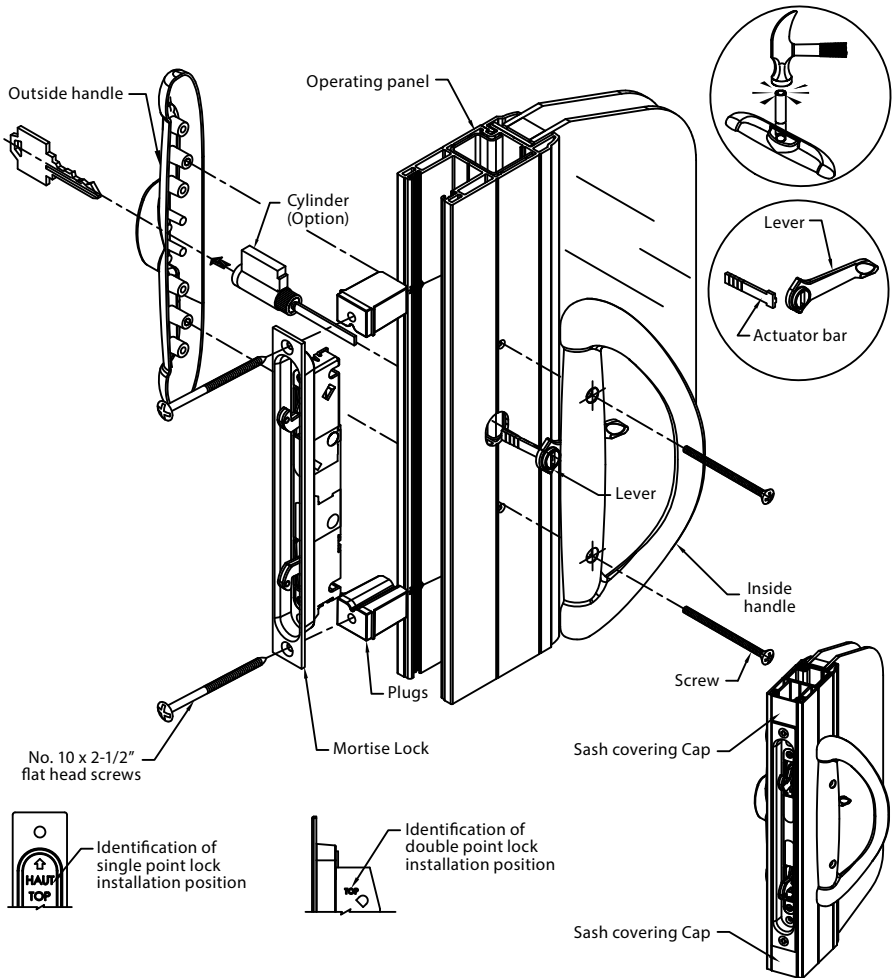

Insert plugs into front cavity of operating panel. On the mortise lock, find the identification TOP for double point lock (this indicates the installation position of the lock). Always install the lock with identification towards the top to ensure proper operation of the lock. Insert lock into front cavity of operating panel and fasten with two (2) #10 x 2-1/2" flat head screws. From the inside, adjust the inside handle making sure the actuator bar is well inserted into the slot of the lock (if the optional cylinder is used, remove the actuator bar from the lever). If the optional cylinder is used, punch out the ring of the exterior handle. If necessary, remove the excess in the hole with a file and insert the cylinder, as illustrated, into the cavity of the outside handle. Position the outside handle in place and secure from the inside with two (2) screws. Install sash covering caps on sash, above and below the lock, as illustrated.

# 7

## Step 7 Preparing the Mainframe

(For Pre-assembled Doors, Go to Step 11)

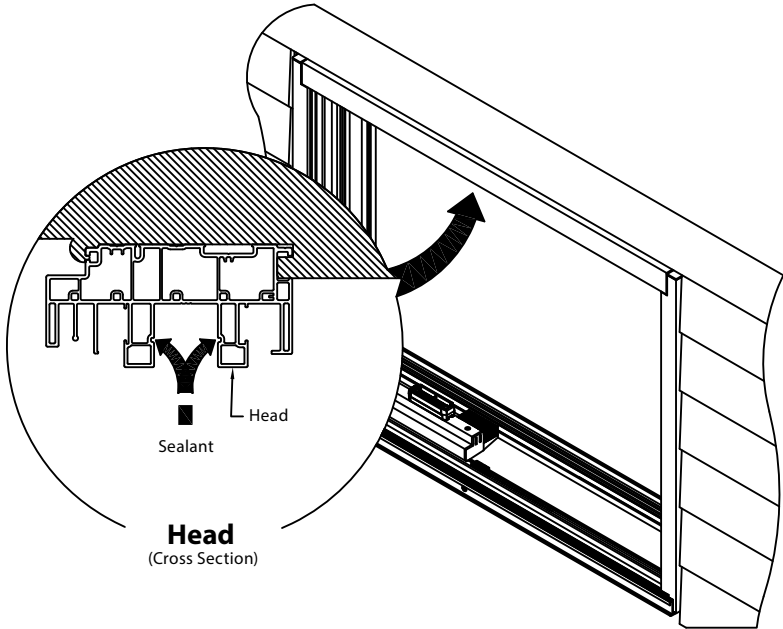

Apply a line of caulking at the center of the head (weatherseal location) on a length of 4" [100mm] in each cavity as shown.

## Step 8 Fixed Panel Installation

8

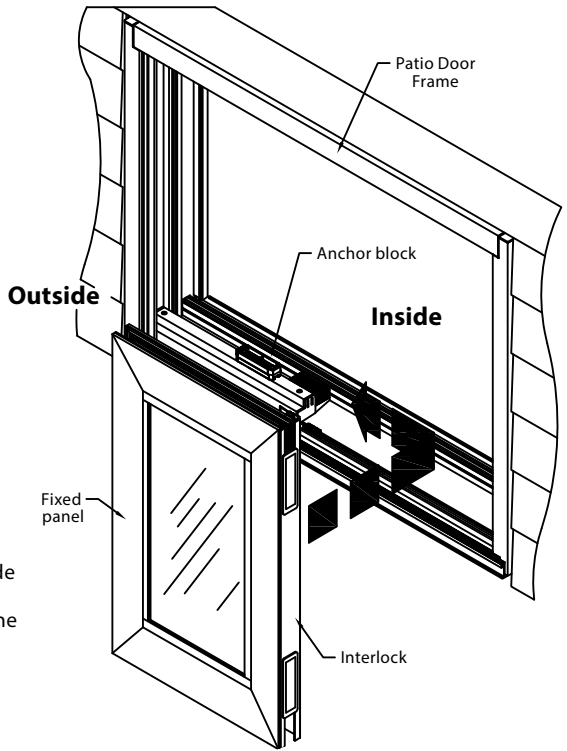
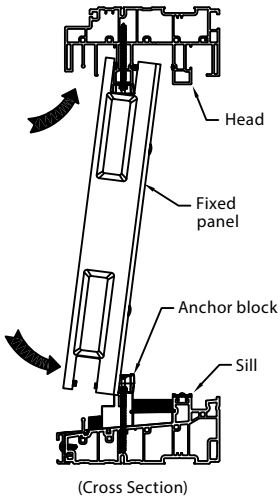

- A** Insert fixed panel into the outside track of the head, bypassing the anchor block and making sure the interlock weatherstrip is facing inward.

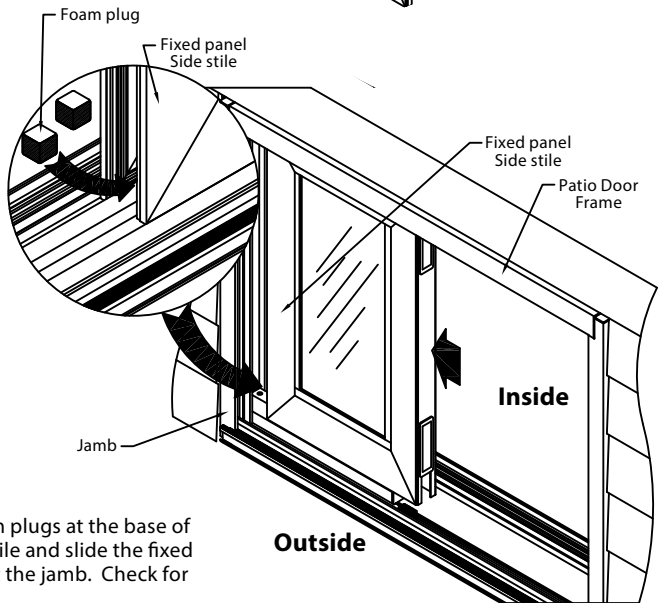
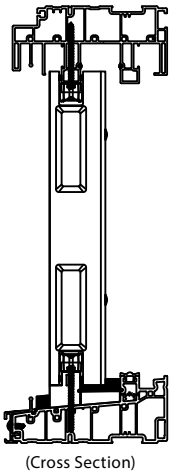

- B** Insert two (2) foam plugs at the base of the vertical side stile and slide the fixed panel fully against the jamb. Check for squareness.

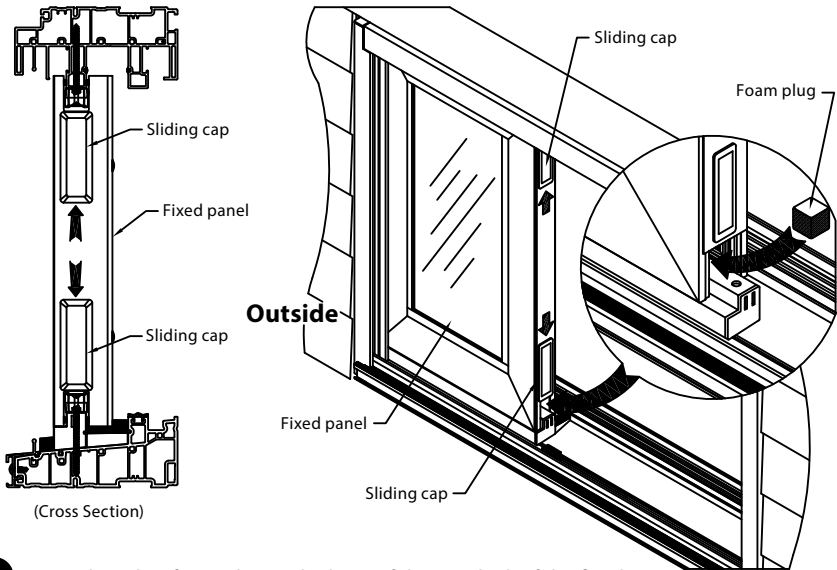
**9****Step 9 Fixed Panel Installation (Continued)**

- A** Insert the other foam plug at the base of the interlock of the fixed panel. Slide caps at each end of the interlock.

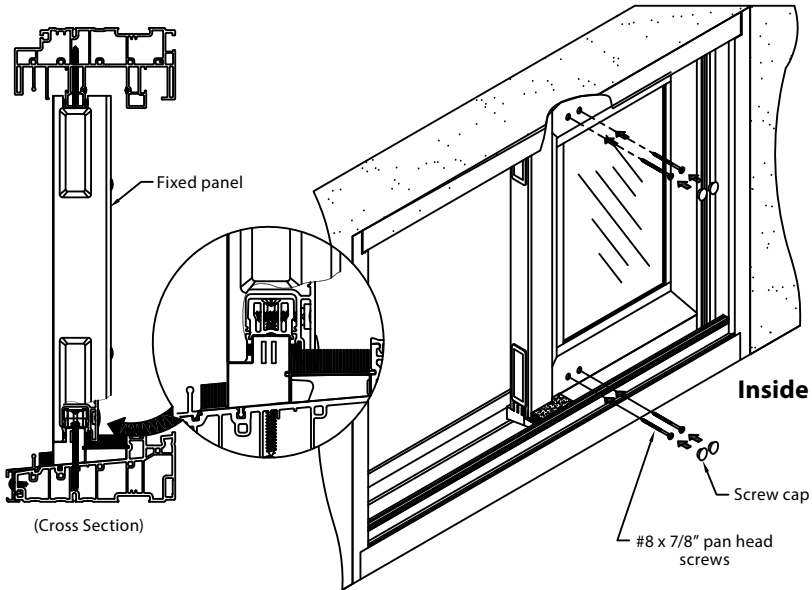

- B** Install four (4) #8 x 7/8" pan head screws into the holes provided at the top and bottom of the horizontal panel rails. Cover each hole with the screw cap.

# Step 10 Operating Panel Installation

10

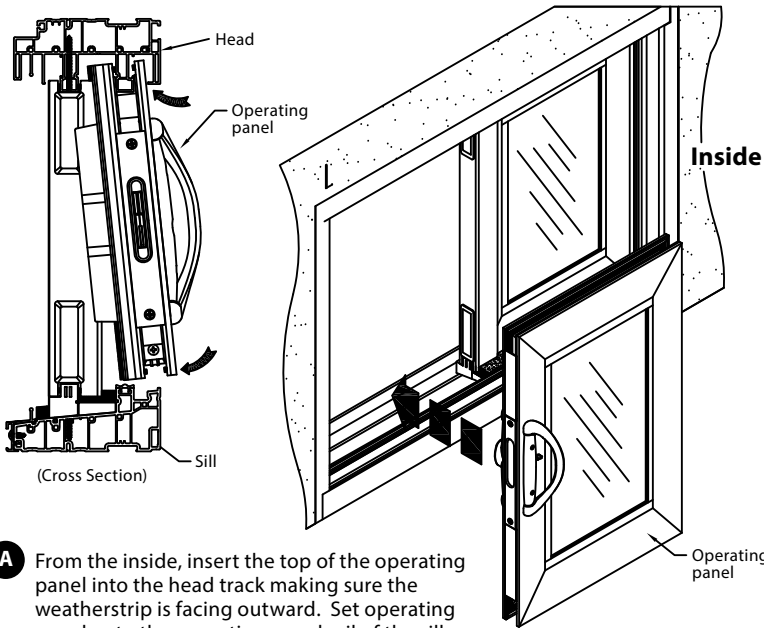

- A** From the inside, insert the top of the operating panel into the head track making sure the weatherstrip is facing outward. Set operating panel onto the operating panel rail of the sill.

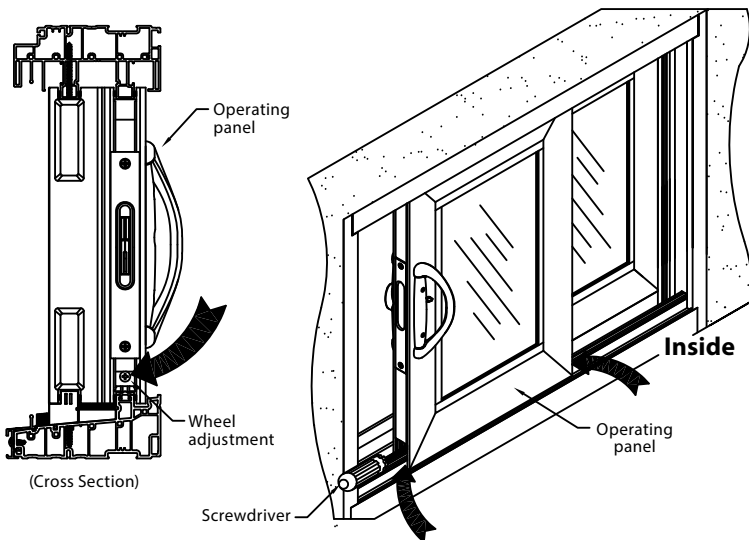

- B** If necessary, adjust height and squareness of the operating panel with the adjustment screws from the wheels (clockwise to raise, counterclockwise to lower).

# 11

## Step 11 Screen Installation

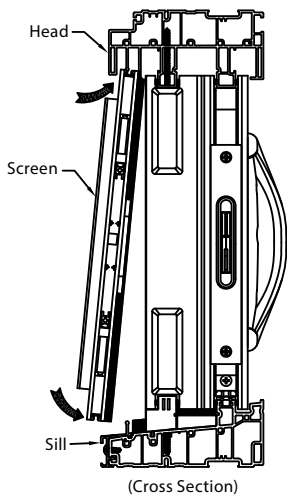

(Cross Section)

- A** From outside, insert the top of the screen in the head track making sure that the insect stopper felt is facing inward. Insert the bottom of the screen onto the rail of the outside sill cladding.

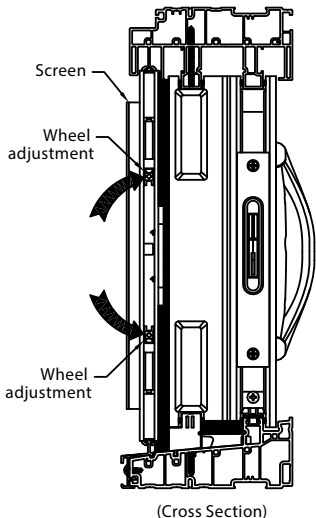
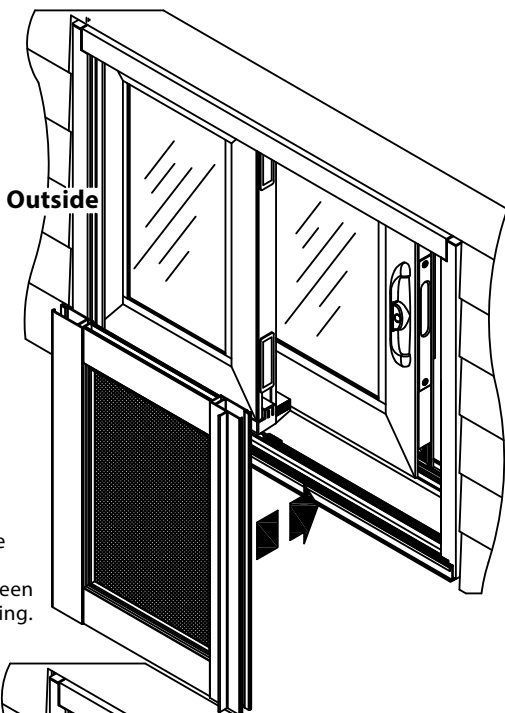

(Cross Section)

- B** If necessary, adjust for squareness and ease of operation with adjustment screws. Adjust bottom wheels for squareness and then top wheels for ease of operation (turn left to increase tightness and right to decrease).

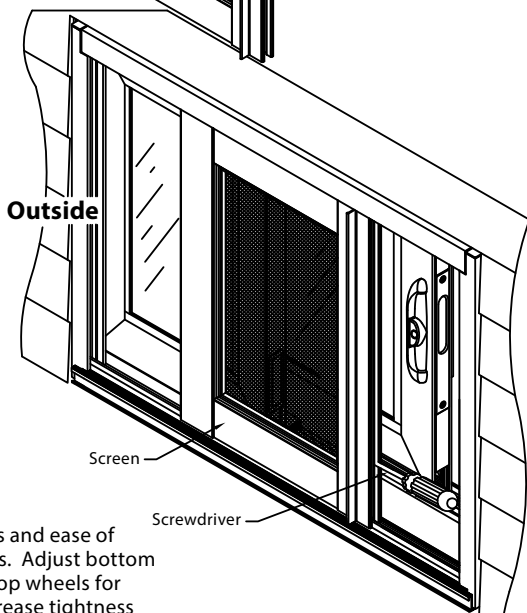

# Step 12 Head Weatherseal and Insect Stop Installation

12

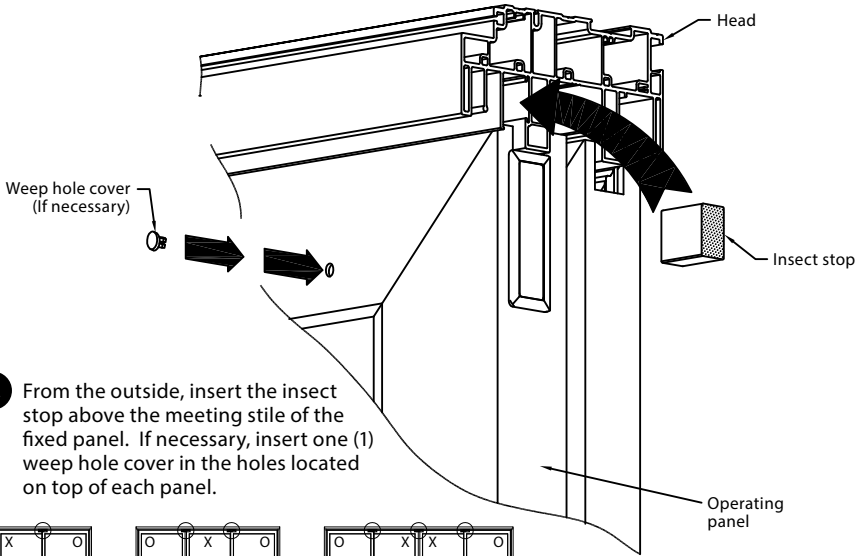

- A** From the outside, insert the insect stop above the meeting stile of the fixed panel. If necessary, insert one (1) weep hole cover in the holes located on top of each panel.

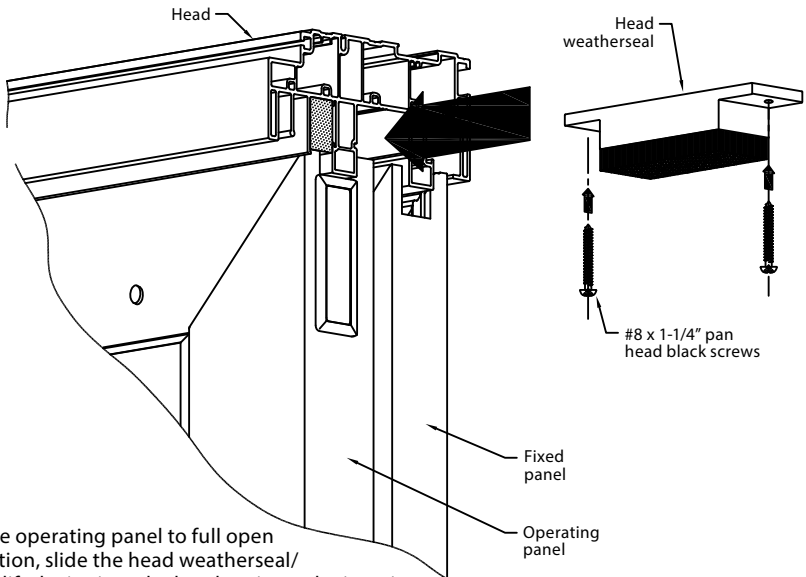
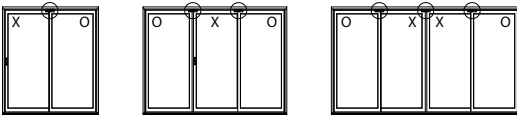

- B** Move operating panel to full open position, slide the head weatherseal/anti-lift device into the head cavity at the junction of the meeting stiles. Fasten head weatherseal with two (2) screws #8 x 1-1/4" pan head black screws.

# 13

## Step 13 Keeper and Sash Stopper Installation

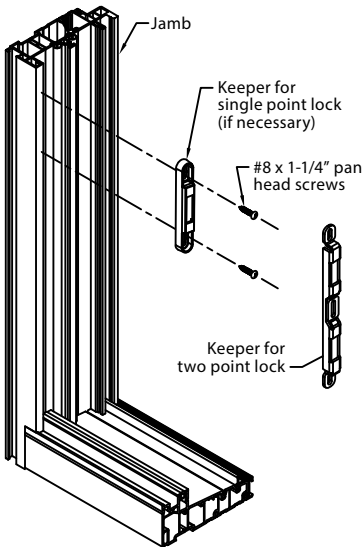

**A** Locate keeper and fix with #8 x 1-1/4" pan head black screws.

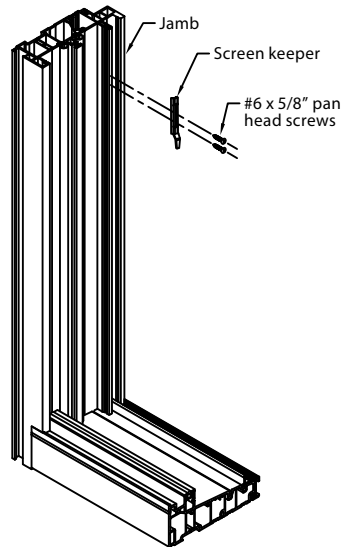

**B** Locate screen keeper and fix with two (2) #6 x 5/8" pan head screws.

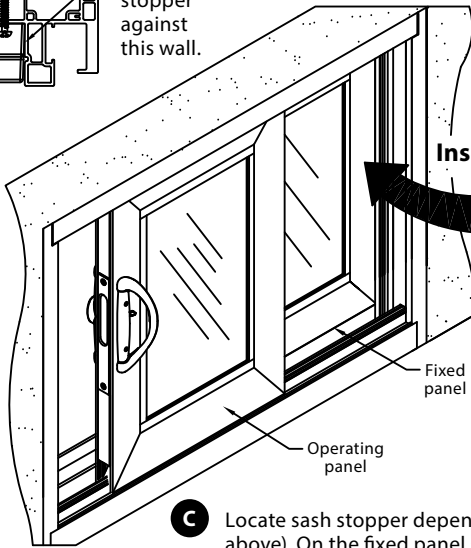
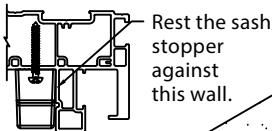

**C** Locate sash stopper depending on type of handle chosen. (See Table above). On the fixed panel side, place the sash stopper at the indicated place. Rest the sash stopper against the vertical wall in order to prevent interference with the fixed panel. Fasten the sash stopper with (2) #8 x 1-1/4" pan head black screws.

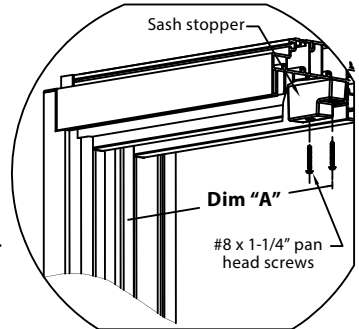

Dimension "A"	
With exterior straight handle	2-3/4"
With exterior "C" handle (white, tan, or clay)	4-1/4"
With exterior plated finished handle	3-7/8"



# Step 14 Mullion Anchor Block Installation for Three (3) Panel Doors

(For Four (4) Panel Doors, Go to Step 17)

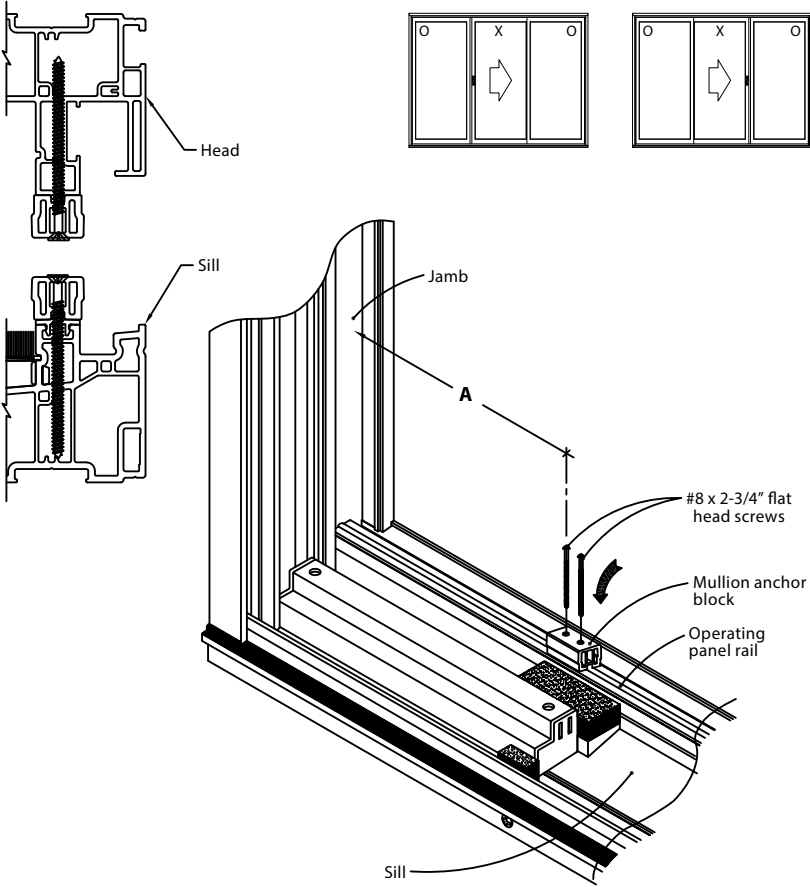

Door	Width	A	Formula
2700	2-3/4"	33.625"	$(\text{Unit Width} / 3) - 1.789"$

**ASSEMBLY SEQUENCE:**

- A** On the head track, locate mullion anchor block from the bottom of the left jamb track as shown (FXLF) or right jamb track (FXRF). Note: Use Dimension A.
- B** On the sill, locate and drill two (2) 0.140" diameter pilot holes through the operating panel rail.
- C** Fix mullion anchor block to the head and sill using (2) #8 x 2-3/4" flat head screws.

# 15

## Step 15 Mullion Assembly for Three (3) Panel Doors

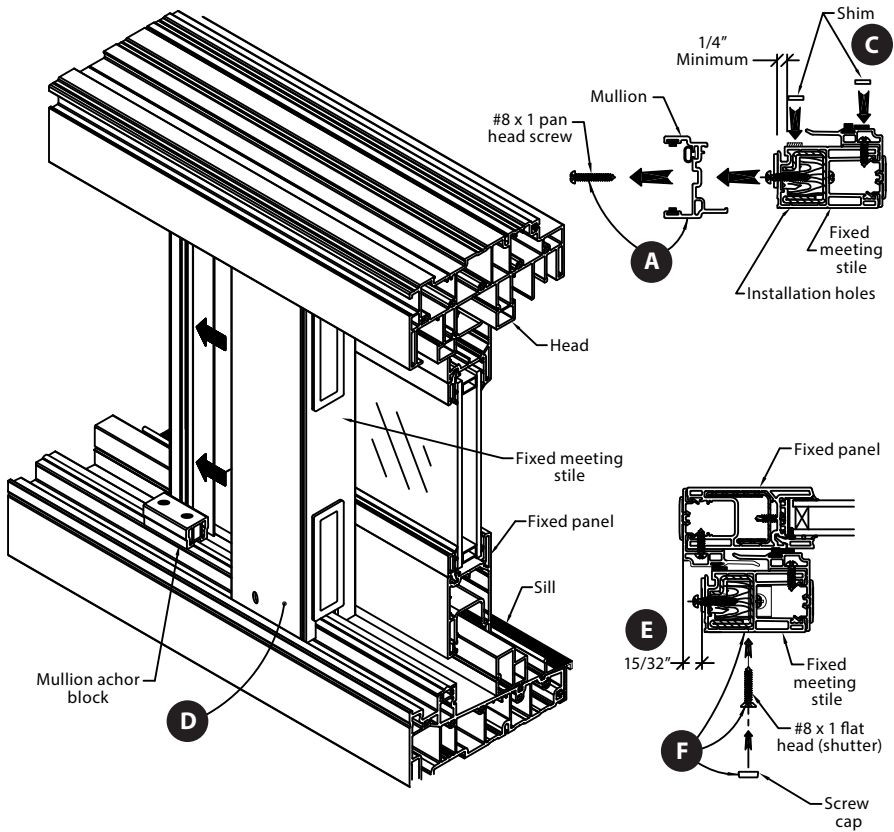

### ASSEMBLY SEQUENCE:

- A** Remove #8 x 1" pan head screws from fixed meeting stile and remove mullion
- B** Machine both ends of the mullion if required.
- C** Stick shims under each of the four (4) installation holes on the fixed meeting stile and three (3) along the weatherstrip as indicated.
- D** Slide the fixed meeting stile on to the mullion anchor blocks.
- E** Install fixed meeting stile in order to keep a distance of 15/32" as shown.
- F** Fasten fixed meeting stile with two (2) #8 x 1" flat head shutter screws. Cover each screw with screw cap.

# Step 16 Final Mullion Assembly for Three (3) Panel Doors

16

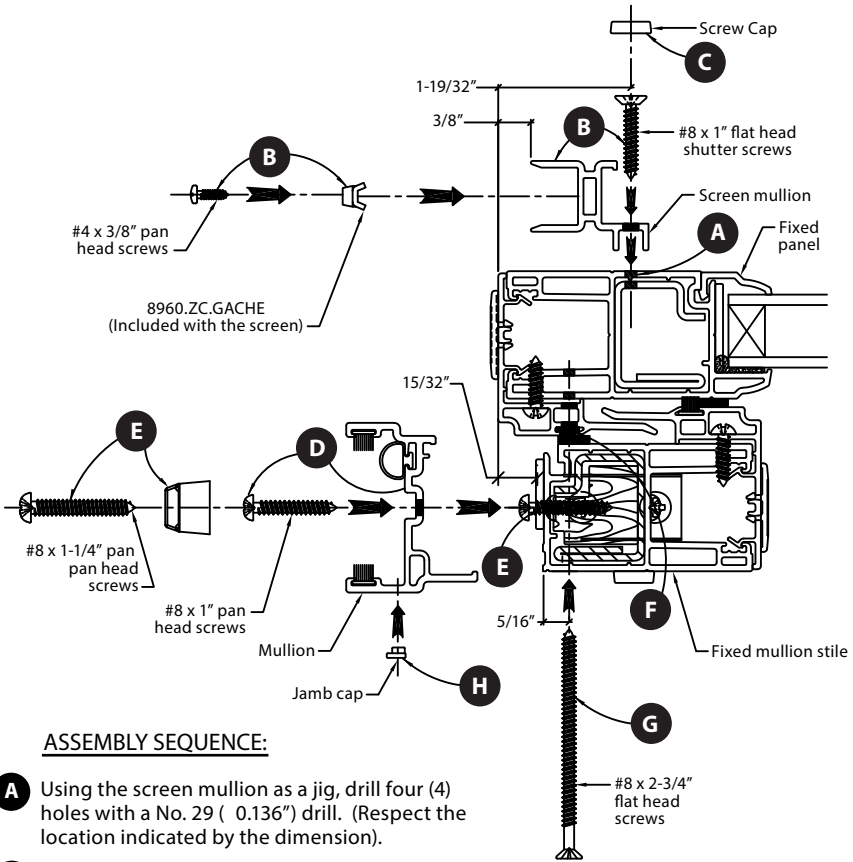

## ASSEMBLY SEQUENCE:

- A** Using the screen mullion as a jig, drill four (4) holes with a No. 29 ( 0.136") drill. (Respect the location indicated by the dimension).
- B** Fasten the screen mullion to the fixed meeting stile using four (4) #8 x 1" flat head shutter screws and fasten the keeper to the screen mullion using two (2) #4 x 3/8" pan head screws.  
Important: When installing a screen keeper for a three (3) panel door, never use the screws included with the keeper since these are too long. Use screws #4 x 3/8" pan head screws which are included with your three (3) panel door hardware bag.
- C** Cover each screw with a screw cap.
- D** Fasten mullion to the fixed meeting stile using four (4) #8 x 1" pan head screws.
- E** Drill two (2) holes with a No. 29 (00.136") drill and fasten the keeper with #8 x 1-1/4" pan head screws.
- F** Using the fixed meeting stile as a jig, drill four (4) holes with a No. 29 (00.136") drill into the fixed panel. (Respect the location indicated by the dimension).
- G** Fasten fixed meeting stile with four (4) #8 x 2-3/4" flat head screws.
- H** If you use a mortise lock, from the inside, stick a No. 8926 jamb cap in the opening for the keeper on mullion. (CAUTION: Too Much PVC cement could damage PVC profiles).

# 17

## Step 17 Mullion Assembly for Four (4) Panel Doors

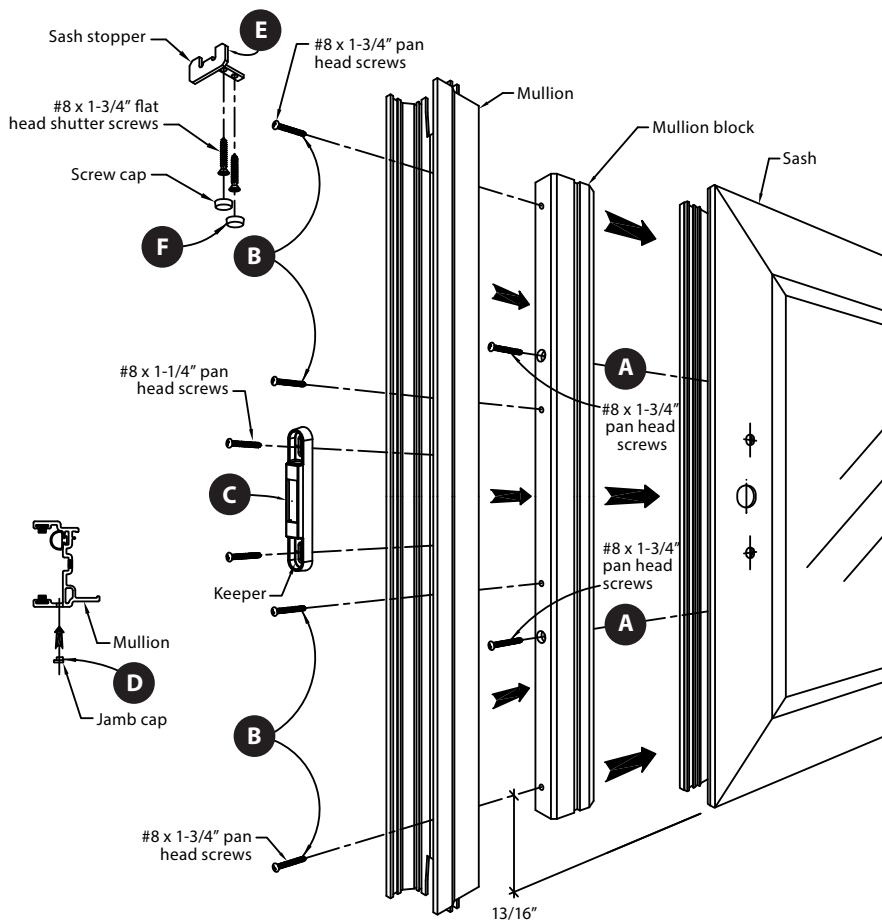

### ASSEMBLY SEQUENCE:

- A** Insert mullion block into the side stile cavity as shown. Fasten mullion block with two (2) #8 x 1-3/4" pan head screws in holes provided.
- B** Install the mullion on the side stile using four (4) No. 9615.ZC.VIS08 screws. Make sure the longest leg is on the inside (Note: It is important that the mullion be pre-machined).
- C** Fix the keeper to the mullion with two (2) #8 x 1-1/4" pan head screws.
- D** If you use a mortise lock, from the inside, stick a jamb cap in the opening for the keeper on mullion. (CAUTION: Too much cement could damage PVC profiles).
- E** Install the sash stopper at the center of the head track using two (2) #8 x 1-3/4" flat head shutter screws.
- F** Cover each screw with a screw cap.

## Step 18 Screen Mullion Assembly for Four (4) Panel Doors

18

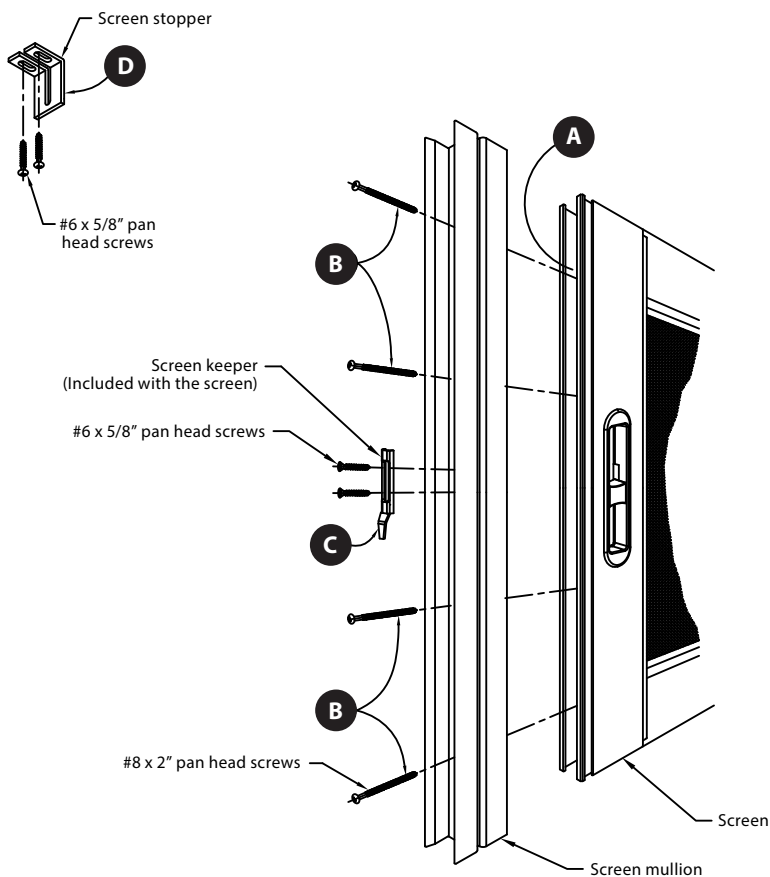

### ASSEMBLY SEQUENCE:

- A** Using the screen mullion as a jig, drill four (4) holes with a No. 29 (0.136") drill bit.
- B** Fix screen mullion using four (4) #8 x 2" pan head screws.
- C** Fix screen keeper to screen mullion using two (2) #6 x 5/8" pan head screws.
- D** Fix the screen stopper at the center of the head track using two (2) #6 x 5/8" pan head screws.

# 19

## Step 19 Secondary Lock and Keeper Installation

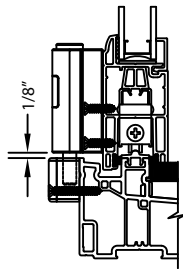
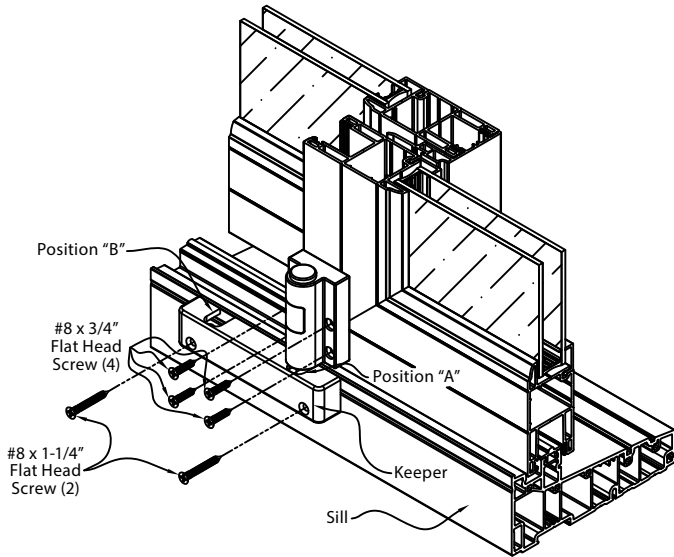

### ASSEMBLY SEQUENCE:

- A** Make sure the operating panel is in a closed and locked position.
- B** Extend the bolt until it is locked into place.
- C** Position the secondary lock onto the vertical stile of the operable panel, aligning the edge of the secondary lock with the edge of the sash and also locating the bottom of the secondary lock approximately 1/8" above the sill of the door.
- D** Mark the location of the secondary lock and anchor with #8 x 3/4" flat head screws provided.
- E** Position the keeper so that the bolt is in the center of the slot at Position "A" (see diagram) and also flush with the top of the sill. Mark holes and use two #8 x 1-1/4" flat head screws provided to mount the keeper to the sill of the unit. (Note: Installation instructions are only given as a reference. As a safety measure, the use of the secondary lock is not a recommendation from Wincore Windows as a safety measure.)



