



# RoboLabs

Incredible machines for fastfood & funfood

## Cotton candy machine Artist (ACB-10-120) 120 V 60 Hz

### User manual



**Read this manual before use and keep  
for future reference!**

PDF version of this manual is available on [www.robolabs.pro](http://www.robolabs.pro)

## Safety requirements



This is the safety alert symbol. It is used to alert you to potential physical injury hazards. Obey all safety messages that follow this symbol to avoid possible injury or death.

### **DANGER**



- Not grounded equipment can cause electric shock. Power outlet **MUST HAVE** proper grounding to avoid electric shock.
- Using excessive water during cleaning can cause short circuit and electric shock. **DO NOT USE** excessive water or water jet for cleaning. **DO NOT SPILL** water on electric panels or parts.
- **ALWAYS** unplug equipment before cleaning or servicing.
- No user serviceable parts inside. **DO NOT OPEN** electric panel unless you are qualified for this.

### **DANGER**



- Improper installation, adjustment, alteration, service or maintenance can cause property damage, injury, or death! Read and understand this manual before installing, servicing, and operating this machine.
- Any modification to the machine design will void the warranty, and may cause machine fault and/or dangerous condition. **DO NOT MODIFY** the design of the machine.

### **WARNING**



- Spinning head is very hot while in operation. **DO NOT TOUCH** until it cools down.

## Safety requirements (continued)

### **WARNING**



- Fast spinning head can crush your fingers. **DO NOT TOUCH** the spinning head until it completely stops.
- Foreign objects in the spinning head may cause eye injury to operator and/or other people. **DO NOT PUT** inside anything except sugar.
- Refilling the spinning head while it is spinning might cause eye injury. **DO NOT REFILL** the spinning head until it completely stops.
- Excessive sugar in the spinning head may cause eye injury to operator and/or other people. **DO NOT OVERFILL** spinning head with sugar.
- **ALWAYS** wait spinning head to stop spinning before sugar refilling.

### **WARNING**



- **ALWAYS WEAR** eye protection while operating or servicing this equipment to avoid eye injury.

### **WARNING**



- Only instructed personnel is allowed to operate the machine.
- This machine is not to be operated by minors.

### **WARNING**



- **DO NOT ALLOW ANYONE** to touch or reach in the machine while operating in public place.

# Contents

<b>1 Overview</b>	<b>5</b>
1.1 Technical specifications . . . . .	5
1.2 Delivery set . . . . .	5
1.3 Getting started . . . . .	5
1.4 Electrical requirements . . . . .	6
1.5 Ambient conditions . . . . .	6
<b>2 Design and operating principle</b>	<b>7</b>
<b>3 Intended use</b>	<b>9</b>
3.1 Operating order . . . . .	9
3.2 Voltage control . . . . .	11
3.3 Motor speed . . . . .	11
3.4 Standby mode . . . . .	12
3.5 “No-snow” cap . . . . .	13
3.6 Important tips . . . . .	14
<b>4 Cleaning and maintenance</b>	<b>15</b>
4.1 Routine cleaning . . . . .	16
4.2 Deep cleaning . . . . .	16
4.3 Brush unit maintenance . . . . .	17
4.4 Conservation . . . . .	18
4.5 Transportation and storage . . . . .	18
<b>5 Troubleshooting</b>	<b>19</b>
<b>6 Quality control check</b>	<b>21</b>
<b>7 Manufacturer details</b>	<b>22</b>
<b>8 Technical service</b>	<b>23</b>
8.1 Standby voltage calibration . . . . .	23
8.2 Motor speed control calibration . . . . .	24
<b>A Parts list</b>	<b>25</b>

# 1 Overview

Artist machine (hereinafter “machine” or “equipment”) is intended to produce cotton candy using pure sugar or sugar mixed with colorant. Due to its special features, the machine allows operator to make servings of cotton candy shaped as a flower or other shapes (an animal, a bird, a cartoon character and so on).

The machine is intended for professional use only.

## 1.1 Technical specifications

Productivity	1,5–2,0 kg/h
“Cold start” time	3 min
“Hot start” time	30 sec
Rated voltage	120 V
Rated frequency	60 Hz
Rated power	1000 W
Dimensions	390x370x340 mm
Weight	14 kg

## 1.2 Delivery set

- 1x Machine
- 1x Power cord
- 1x Floss pan
- 1x Measuring cup
- 1x No-snow cap
- 1x User manual

## 1.3 Getting started

1. Unpack machine and keep the package for future shipping needs.
2. Check the delivery set.
3. Place the machine on a stable table or cart.
4. Fully raise ALL FOUR transport fastening nuts (pos.4 Fig.1) until they reach the floss pan supports (pos.5 Fig.1).
5. Remove protective film from the floss pan (pos.7 Fig.1), wash the pan with dish soap, rinse with water and wipe dry.
6. Rinse “No-snow cap” (see Fig.5) with warm water, wipe dry.

7. Place the floss pan on the machine making sure the indentations rest on the floss pan supports.

## 1.4 Electrical requirements

### **DANGER**



- Power outlet **MUST** have proper grounding to avoid electric shock.
- If supply cord damaged, it **MUST** be replaced by manufacturer, service agent, or qualified persons in order to avoid hazard.
- **ALWAYS** keep power cord and plug off the floor and moisture.
- **DO NOT USE** any kind of adapters, inverters, or extension cords, as it might affect the overall performance of the machine, and impose additional risks.

Machine is supplied with power cord fitted with NEMA L5-20P plug. You **MUST** ensure that your electrician provides you with outlet receptacle NEMA L5-20, which is properly grounded.

## 1.5 Ambient conditions

This equipment is designed to be operated at the ambient temperature from +5°C to +40°C (+41°F to +104°F) and relative humidity not more than 45% at 40°C (104°F) while using at altitudes not exceeding 1000 m over the sea level. The temperature decreasing is related to RH increasing, for example, 90% of RH at 20°C (68°F). This equipment **MUST NOT** be exposed to precipitations of any kind (rain, snow and so on).

As temperature and humidity increase above these ranges, cotton candy can still be produced, but it will be very dense and heavy. Most importantly, being a sugar product, it may begin to melt shortly after being production.

## 2 Design and operating principle



Figure 1: Main components of the machine

The main parts of the machine represented on the Fig.1: 1 – Housing; 2 – Transportation handle; 3 – Spring mounted support; 4 – Transport fastening nut; 5 – Floss pan support; 6 – Spinning head with heater; 7 – Floss pan; 8 – Rotor; 9 – Stator; 10 – Chassis; 11 – Rubber leg.

The Spinning head (6) and electric motor are mounted on the Chassis (10), which itself is connected to the Housing (1) by four spring-mounted supports (3). These spring supports dampen vibrations and allow the motor to self-balance during operation.

An electric motor drives the spinning head at high rate. The spinning head rotates with the sugar mix inside where the heating element warms the sugar up to its flow point 120–140°C (250–285°F). Due to centrifugal force, the melted sugar flies through slits in the sidewall, where it instantly cools and crystallizes, turning into candy floss.

An impeller attached to the Rotor (8) rotates along with the spinning head, producing a powerful upward airflow. The Stator (9) prevents operators and objects from coming into contact with the rapidly rotating impeller, and also rectifies the airflow. The airflow lifts the cotton candy upwards. Sugar particles that are too heavy accumulate on the inner surface of the Floss pan (7), installed on Floss pan supports (5).

Four Transport fastening nuts (4) secure the spring-loaded chassis during transportation to prevent damage to the motor. They are located on the threaded support studs at each corner of the chassis. Four rubber legs (11) ensure machine's firm contact to the surface where it is installed, and also dampen vibrations.

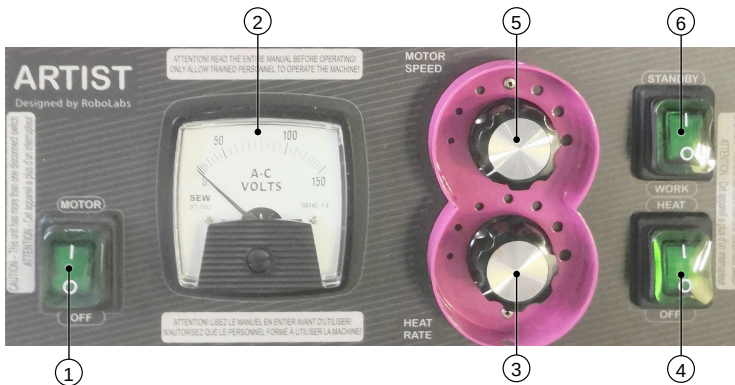

Figure 2: Control panel

The control panel represented on Fig.2: 1 – Motor switch; 2 – Voltmeter; 3 – Heating adjustment knob; 4 – Heating switch; 5 – Motor speed adjustment knob; 6 – Standby switch.

The motor switch (1) turns on the motor and energizes the rest of the machine. Heating switch (4) turns on the heating element. Adjustment knob (3) regulates power to the heating element and thus controls its temperature. Voltmeter (2) indicates actual voltage supplied to the heating element.

Adjustment knob (5) regulates speed of motor rotation and thus intensity of the airflow. Standby switch (6) turns on standby mode, when small power supplied to the heating element, keeping it warm, so the operation can be resumed shortly.



### 3 Intended use

#### CAUTION



- DO NOT TURN ON until transport fastening nuts are FULLY RAISED. Otherwise it may cause excessive vibration during whole machine operation, and lead to machine failure.
- Vibration of the spring mounted chassis during spinning head acceleration and deceleration IS NORMAL.

#### 3.1 Operating order

1. BEFORE plugging machine in the outlet receptacle, MAKE SURE all three switches (pos.1, 4, 6 Fig.2) are in (0) position.
2. Fill measuring cup with flossugar and load it in the spinning head.
3. Quickly rotate the head manually to distribute the sugar evenly.
4. You will need sticks, rods or cones to spin inside the plastic pan to collect the cotton floss as it is produced. These can be made of wood, paper or plastic. Wood sticks and plastic straws should be soaked in water first in order to create better adhesion for the floss.
5. Turn the main power switch (pos.1 Fig.2) ON, and the spinning head will begin to rotate.
6. Turn the heating switch (pos.4 Fig.2) ON.
7. Use the knob (pos.3 Fig.2) to adjust voltage on voltmeter (pos.2 Fig.2) to 70-80 V<sup>1</sup>.
8. Depending on conditions, it will take about one minute to warm up the head to operating temperature. You will usually smell the candy aroma between 10 to 15 seconds before production begins.

---

<sup>1</sup>When setting up at a new location, the power level must be adjusted according to the environmental conditions. If cotton candy comes out too slow, increase the voltage slightly. Alternatively, decreasing voltage will slow production. When you change locations or if the temperature or humidity changes later in the day (if working outdoors) then you may need to make additional adjustments.

9. Cotton candy will fly out upwards in a vertical column or “sleeve.” This “sleeve” can be wrapped or wound around a stick by rapidly turning or spinning the stick with your fingers in a clockwise direction (see below). You will usually want to collect floss between 8” to 14” above the spinning head, though you can adjust for conditions and the size of the serving, see Fig.3.



Figure 3: Collecting candy floss

10. Special shape of the floss pan allows operator to bring the stick very close to the head while collecting the floss. This is very handy while making a cotton candy of complex shape (a flower, an animal or a bird, a cartoon character and so on).

### **Shutting down**

11. Turn off the heating switch (pos.4 Fig.2) and capture the remaining cotton candy as the head cools down. When the head cools to the point that “snow” is produced, then cover the head with the “No Snow” cap and allow the head spin for 3-4 minutes to fully cool down before turning off the motor switch (pos.1 Fig.2).
12. Once cool to the touch, wipe out the inside of the “No Snow” cap, and put it back over the spinning head for protection. You can also cover this with a paper or plastic bag to protect the flossugar from dust, debris and insects.
13. The machine and Floss Pan should be wiped down with a damp cloth to remove excess flossugar as needed.

When shutting down for periods of less than 24 hours, you may leave any remaining flossugar in the spinning head.

If you are shutting down for longer than one day, then you should perform a complete cleaning of the spinning head as described in the Technical Maintenance section below.

Do not leave unused flossugar in the spinning head for more than a day or two as it can harden/caramelize and effect the balance of the head during future sessions, which could ultimately result in failure of the machine.

During transportation always secure the chassis using the transportation lock-down nuts. This will prevent possible damage of the machine and prolong the lifetime.

### **3.2 Voltage control**

Using too high voltage values could result in overheating the flossugar and the the cotton candy would then be produced in a narrow rope that is difficult to capture.

In an extreme scenario, the floss would be burnt and ejected as irregular flakes and sugar dust that would create a mess covering everything nearby in the immediate area. The Fig.4 below shows an example of mildly overheated heating element. Notice the cotton candy is rising more like a “rope” than a wide “sleeve.” Keep in mind that once the heating element and the whole spinning head have reached such a high temperature, reducing the voltage will not immediately produce the desired effect.

Due to thermal lag, any changes in voltage will only slowly take effect over the next 15 to 30 seconds (or longer, depending on ambient temperatures) so it is very important to avoid overheating the element in the first place.

### **3.3 Motor speed**

If candy floss comes out too fast, it is possible to reduce the rotation speed by the adjustment knob (pos.5 Fig.2).

The motor circuit includes a time relay set for 12 seconds, so each time the motor switch is turned on, the motor always spins at its maximum rate for 12 seconds, and after then the speed is reduced accord-



Figure 4: "Rope" cotton candy

ingly to the position of the adjustment knob. This provides stable and smooth motor operation and minimizes inrush current impact.

### 3.4 Standby mode

If there are no customers at the moment, it is convenient to keep the spinning head warmed up to be able to resume operation very quick. To turn on the standby mode set the switch (pos.6 Fig.2) to STANDBY position (the switch will be illuminated).

In this mode, a half of of the full power to be supplied to the heating element, no matter which position the heating adjustment knob (pos.3 Fig.2) is set to.

To resume operation, set the switch to WORK position (the switch illumination will be off).

### 3.5 “No-snow” cap

In the production of cotton candy, “snow” includes flakes, flecks, small filaments and sugar dust that are all too small to be collected in the normal winding process of producing a cotton candy serving. There are four situations when “snow” will be emitted from the spinning head:

1. At the very beginning of operation.
2. During the end of production.
3. When there is not enough flossugar remaining.
4. If the coil and sidewall are overheated.

In both the beginning and ending of operation, snow is produced as the heating element crosses the temperature threshold at which it can evenly and uniformly melt the flossugar in the bowl into quality cotton candy floss.

The same is true when there is not enough flossugar left in the head because the remaining sugar will not be evenly distributed and that will cause some of the material to overheat.

Finally, if the head becomes extremely overheated then brunt sugar flecks and dust will be produced instead. Paying attention to Voltage regulation and not excessively preheating the heater during cold startup will ensure this does not happen.

Regardless of the cause, you can prevent the distribution of snow (which can create a mess) by placing the “No-Snow” cap (see Fig.5) over the spinning head, where it will capture the snow as it is ejected.



Figure 5: “No-snow” cap

However, you should not leave the “No-Snow” cap in place for long periods of time as it will eventually become filled with floss and this will then collect on the spinning head itself.

To help prevent this, the inside of the “No-snow” cap should be wiped off in between each use to prevent accumulation of spent floss-sugar. If you do notice melted or burnt sugar accumulating on top or lip of the spinning head cover, or excessive buildup on the sidewall, then this should be scraped off before proceeding.

This can be done using a wooden bamboo skewer or stick (never metal) while the head is spinning. Gently put the tip of a stick into the inner right-side edge of the cover and allow the rotation of the head against the stick to scrape off any sugar accumulation. This can be repeated on the outside of the sidewall as well, again only on the right-side of the spinning head.

This cleaning should not be done when customers are nearby as small pieces of sugar could fly some distance and pose a risk to the face and eyes.

### **3.6 Important tips**

1. Use ONLY 100% pure granulated sugar (beet or cane).
2. DO NOT USE sugar powder, sugar with added starch, dextrose, corn syrup and so on. Doing so will lead to poor quality floss and/or quick clogging of the spinning head.
3. To make colored and flavored cotton candy use flavoring mix (Floss Art, for example), or ready to use flossugar.
4. DO NOT USE excessive flavoring mix! Doing so will:
  - increase the cost of production;
  - make the product tastes bitter;
  - lead to spinning head clogging;
  - lead to excessive carbon build-up inside the spinning head.

**HINT:** if you want deeper color, sprinkle the flossugar mixture with water (1 tablespoon of water per 2kg/5lbs of sugar) and mix well before put in the machine.

## 4 Cleaning and maintenance

### **DANGER**



- Electric shock hazard! **DO NOT** use excessive water or water jet to clean the machine. **DO NOT** spill water or other liquids on electric parts of the machine, including housing.
- **ALWAYS** unplug the machine before cleaning.
- **ALWAYS** keep power cord and plug off the floor and moisture.
- **DO NOT IMMERSE** spinning head in water.

### **WARNING**



- **WAIT** until spinning head is cooled down before servicing.

### **WARNING**



- Use food-grade cleaners **ONLY**.
- **DO NOT USE** aggressive cleaners, or sharp items, or abrasives for cleaning.

The purpose of technical maintenance is to keep the unit operable during the entire service life.

### **Recommended schedule**

Depending on how intensively machine used, and the supplies, it might require more frequent cleaning.

Routine cleaning	once a day
Deep cleaning	twice a month
Brush unit maintenance	every 6 months

## 4.1 Routine cleaning

1. Unplug the machine from the wall outlet.
2. Take the Floss pan and “No-snow” cap off from the machine; rinse with warm water. Wipe dry immediately.
3. Remove residues of sugar from outer surfaces of the machine with a clean soft damp cloth. Wipe dry immediately.

## 4.2 Deep cleaning

During long-term operation, the heating element and sidewall slits can become clogged with sugar and carbon deposits. This may significantly reduce both productivity and the quality of the cotton candy produced. To make a deep cleaning it is necessary to disassemble the machine.

1. Unplug the machine from the wall outlet.
2. Remove all sugar from the head, turning the machine upside-down if necessary.
3. Detach spinning head cover by removing three flat-head screws, see Fig.6. If the cover is ‘glued’ to the head, gently tap with the screwdriver handle in order to loosen the parts. Rinse the cover with water and wipe dry immediately.
4. Detach upper part of the stator by removing four screws, see Fig.7. Rinse this part with water and wipe dry immediately.

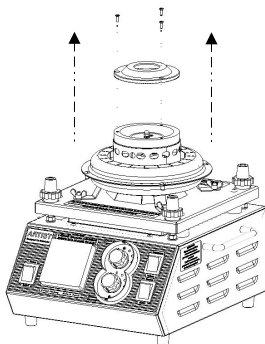

Figure 6

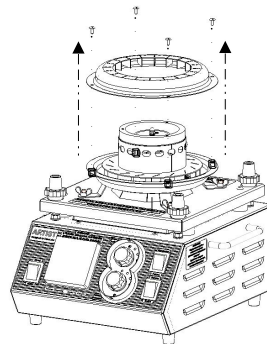

Figure 7



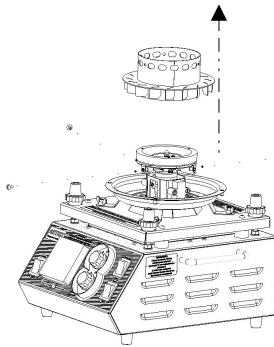

Figure 8

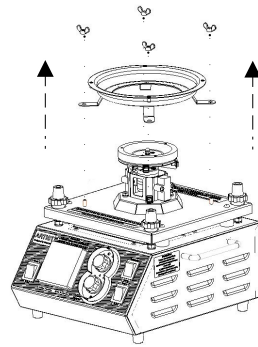

Figure 9

5. Detach rotor by removing three screws, see Fig.8. Rinse rotor with water and wipe dry immediately.
6. Detach lower part of the stator by removing four wing nuts, see Fig.9. Rinse this part with water and wipe dry immediately.
7. Assemble in the reverse order.

### 4.3 Brush unit maintenance

As with most electrical motors, the machine utilizes brushes and slip rings which are subject to wear and require inspection, maintenance and eventual replacement.

1. Disassemble the machine as described in Deep cleaning section.
2. Remove two screws that hold the hatch (pos.1 Fig.10); remove the hatch.

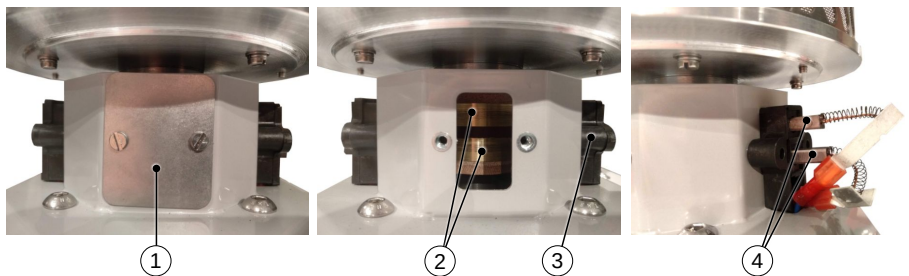

Figure 10: Brush unit maintenance

3. Inspect the slip rings (pos.2 Fig.10) for bumps and color changes. The rings should fit closely to insulators and should not show excessive wear.
4. Slip rings are made of high-grade brass and will last years if properly serviced. If the slip rings are excessively worn or are covered with bumps, they need to be replaced by qualified service staff.
5. Remove all dust, debris and tarnish from the slip rings.
6. Remove two screws to open the brush unit (pos.3 Fig.10)
7. Take out two carbon electrodes (pos.4 Fig.10).
8. If electrodes are significantly worn out, or broken, the brush unit should be replaced.
9. Repeat for the other brush unit.
10. **IMPORTANT: After installing new brushes, allow the motor to run for 15 minutes before turning on the heating element. This will allow the brushes to conform to the slip rings, avoiding the potential for arcing under load.**

#### **4.4 Conservation**

If the unit is not used for a prolonged period of time, then the routine maintenance must be performed before it is placed back into service.

#### **4.5 Transportation and storage**

The equipment may be transported by any kind of covered vehicle, in accordance with transportation rules for this kind of vehicle. Ambient temperature during the transportation and storage must be between minus 25°C and +55°C.

## 5 Troubleshooting

### **DANGER**



- Diagnostic procedures involving electric testing and internal components testing **MUST be performed ONLY by a skilled technician!**

### **Machine doesn't turn on (head doesn't spin)**

- Ensure machine is plugged in.
- Ensure motor switch is in MOTOR position.
- Check voltage in the wall outlet. Too low voltage may cause this issue.
- Check power cord. Replace fault power cord.
- Check motor coils with a tester. Replace fault motor.
- Check internal wiring for open circuit. Fix open circuit.
- Check capacitor C. Replace fault capacitor.
- Ensure motor speed adjustment knob is set to maximum. Perform motor speed calibration procedure. Check variable resistors RP3, RP4, and also the solid state relay VS1. Replace fault component(s).

### **Machine doesn't produce cotton candy**

- Ensure heating switch is in HEAT position and standby switch is in WORK position.
- Increase voltage supplied to the heating element by rotating heating adjustment knob.
- Check heating element EK. If heating element is fault, replace the spinning head.
- Check brush units. Replace fault brush unit(s).
- Check power regulator. Replace fault power regulator.
- Check variable resistor RP1, fixed resistor R, and power regulator VS2. Replace fault component(s).
- Check internal wiring for open circuit. Fix open circuit.

## **Excessive vibration during operation**

- FULLY RAISE all four transport fastening nuts.
- Distribute sugar inside the spinning head evenly.
- Ensure there are no foreign objects inside spinning head. Remove if any.

## **Floss comes out as flakes, smoke coming out from the head, floss coming out as a narrow "rope"**

- DO NOT use sugar with added starch or similar. Ensure all recommendation regarding sugar used are met, see **Important tips** section above.
- Decrease voltage supplied to heating element with heating adjustment knob.
- Clean spinning head.
- Check power regulator VS2, variable resistor RP1, fixed resistor R. Replace fault component(s).

## **Cotton candy melts fast**

- Sugar absorbs moisture easily. High relative humidity of ambient air makes cotton candy melts fast. Choose working locations with lower relative humidity levels.

## **Low productivity**

- Increase voltage supplied to heating element with heating adjustment knob.
- Clean spinning head.
- Check voltage in the wall outlet. Low voltage causes low productivity.

## **Floss coming out while standby mode is activated**

- Perform standby voltage calibration procedure.
- Check variable resistor RP2, inductive relay K. Replace fault component(s).
- Check internal wiring for open circuit. Fix open circuit.

## 6 Quality control check

Cotton candy machine, ACB-10-120

\_\_\_\_\_

Product name, model

\_\_\_\_\_

Serial no.

The equipment is made with accordance to mandatory requirements of the state standards, actual technical documentation, and approved for use.

QC Engineer

STAMP HERE

\_\_\_\_\_

Signature

\_\_\_\_\_

Full name

\_\_\_\_\_

DD.MM.YYYY

The manufacturer guarantees trouble-free operation of the equipment during 12 months from the date of receiving the equipment by a dealer (in accordance with transport documentation); or, in case of purchase directly through Trapeza LLC or RoboLabs Ltd., from the date of purchase, given that terms of using, transportation, and storage are met.

The warranty repair is performed upon presentation of this manual and filled warranty card with the seller's seal and the date of sale. Technical specifications of the equipment can be changed by manufacturer at any time due to improvements and/or other reasons. Technical specifications stated in this document are intended to act as a reference point, which is necessary to evaluate suitability of the equipment for the customer's needs, and are not the subject of warranty policy.

The information stated in this document has been thoroughly checked and considered as accurate one; nevertheless, the manufacturer is not responsible for any typographical errors or misprints.

***Due to constant improvement of the equipment, technical specifications are subject to change without prior notice!***

## **7 Manufacturer details**

NPO Tvertorgmash LLC  
11 Industrialnaya Street, Tver, 170100 Russia  
Technical support:  
Email: support@robolabs.pro  
Phone: +7 495 956 4000

## 8 Technical service

### **DANGER**



- **THIS SECTION IS FOR SKILLED TECHNICIANS ONLY!**
- DO NOT open housing of machine unless you are qualified for this.
- ALWAYS unplug machine before servicing.

### **WARNING**



- Spinning head might be very hot. Wait until spinning head is cooled down before servicing.

### **WARNING**



- ALWAYS wear eye protection while servicing this equipment to avoid possible injury.

### 8.1 Standby voltage calibration

Depending on the actual voltage in the power supply, it might be required to calibrate amount of power supplied to the heater when standby mode is activated.

1. Remove silicone sealant that fixes the rod of calibrating resistor marked "H", see Fig.11.
2. Adjust the resistor by rotating the rod so that the spinning head remains warm, but no cotton candy comes out even during 20-30 minutes long operation in standby mode.
3. Apply silicone sealant on the rod to secure it in place, thus to avoid loosening and detune.

## 8.2 Motor speed control calibration

Depending on the actual voltage in the power supply, it might be required to calibrate the motor speed control circuit.

1. Remove silicone sealant that fixes the rod of calibrating resistor marked "M", see Fig.11.
2. Turn the motor speed adjustment knob (pos.3 Fig.2) all the way to the left, at the minimum.
3. Turn the motor on.
4. Adjust the calibrating resistor by rotating the (M) rod, so that the measured speed of rotation is around 2300 rpm.
5. Apply silicone sealant on the rod to secure it in place, thus to avoid loosening and detune.

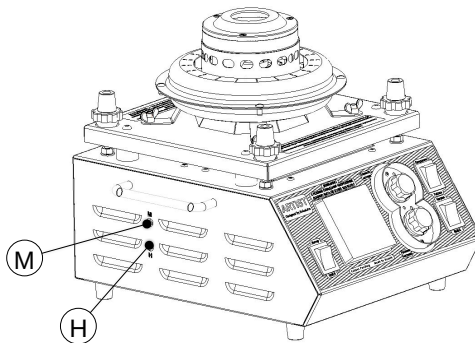
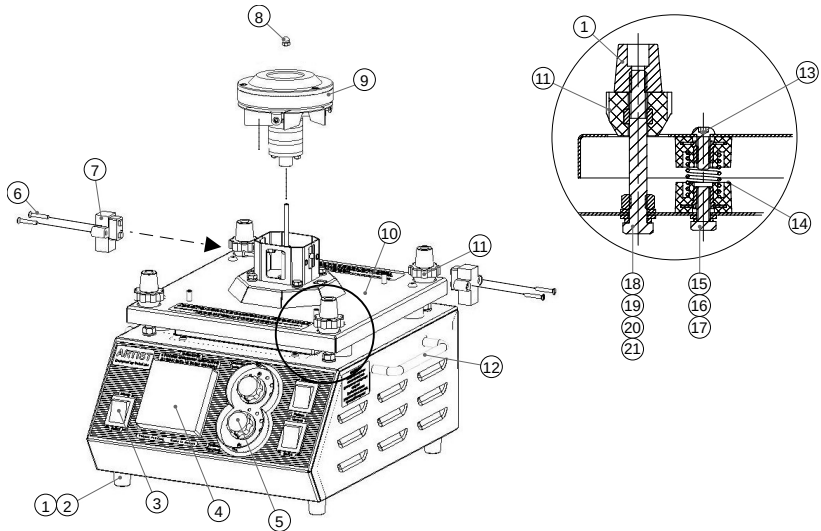

Figure 11: Calibration resistors



## A Parts list



Pos.	Item	QTY	Part no.
1	Rubber leg	8	21196
2	Cheese head screw M4x20 DIN 84	4	30817
3	Rocker switch (SA1-SA3)	3	17110
4	Voltmeter (PV)	1	22625
5	Adjustment knob	2	25334
6	Flush head screw M4x25 DIN 963	4	30551
7	Brush unit (XA1,XA2)	2	7248
8	Cap nut M5 DIN 1587	1	30548
9	Spinning head assembled	1	26129
10	Chassis	1	25357
11	Transport fastening nut	4	25338
12	Transportation handle	2	26200
13	Button head screw M6x16 ISO 7380	4	30821
14	Spring-loaded support	4	24799
15	Bolt M6x16 DIN 933	4	25290
16	Flat washer M6 DIN 125	4	26059
17	Lock washer M6 DIN 127	4	25293
18	Bolt M8x70 DIN 933	4	25914
19	Nut M8 DIN 934	4	30747
20	Flat washer M8 DIN 125	8	30748
21	Lock washer M8 DIN 127	4	30749

# Parts list (continued)

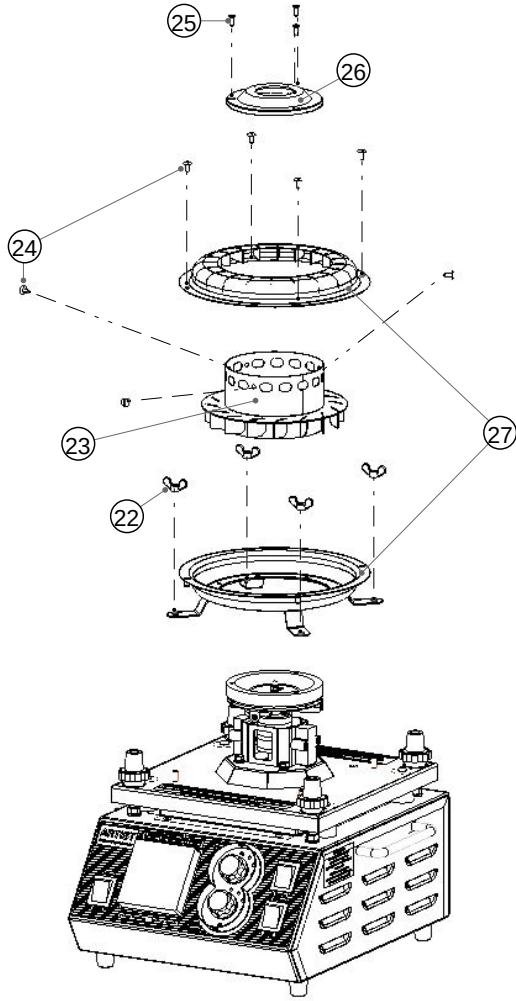

Pos.	Item	QTY	Part no.
22	Wing nut M6 DIN 315	4	16048
23	Rotor	1	21513
24	Button head screw M4x10	7	22017
25	Flush head screw M4x12 DIN 963	3	23583
26	Spinning head cover	1	25335
27	Stator	1	21695

## Parts list (continued)

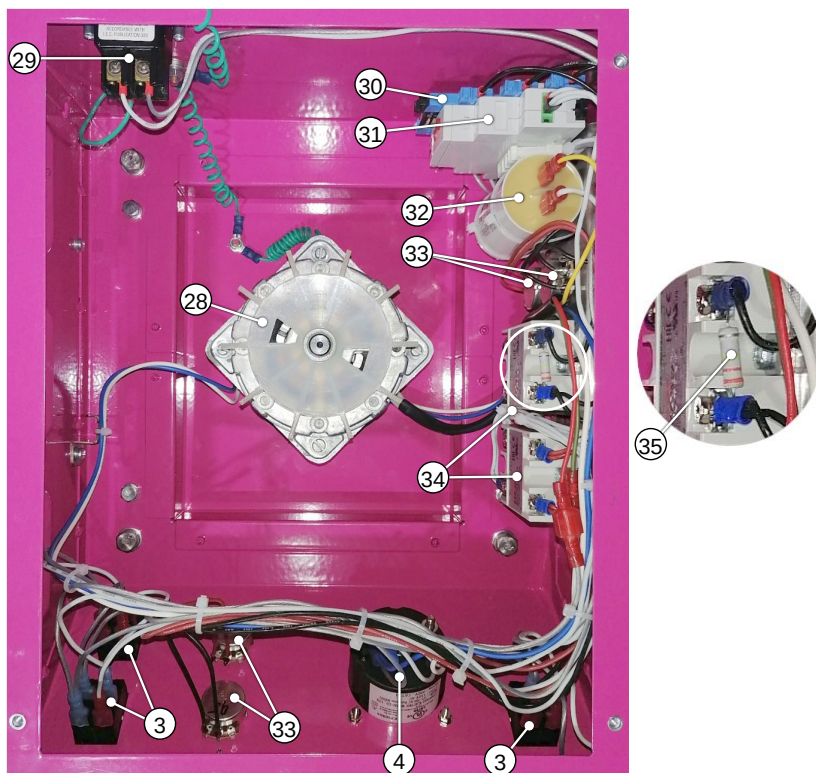

Pos.	Item	QTY	Part no.
3	Rocker switch (SA1-SA3)	3	17110
4	Voltmeter (PV)	1	22625
28	AC motor (M)	1	30476
29	AC inlet	1	17023
30	Inductive relay (K)	1	30475
31	Time relay (KT)	1	25283
32	Capacitor (C)	1	22627
33	Variable resistor (RP1-RP4)	4	22623
34	Power regulator (VS)	2	17724
35	Fixed resistor (R)	1	30492

## Parts list (continued)



Pos.	Item	QTY	Part no.
37	Floss pan	1	25285
38	No-snow cap	1	25336
39	Measuring cup	1	25337
40	Power cord	1	24170