

CONNECTING BUILDPRO TABLES

Joining two Alpha 5/8" tables together.



Instructions for joining two Alpha 5/8" tables together using **T832608** flush mount connecting bolts





Preparation

Begin by ensuring that both tables are on a level surface.

Next, level and match both tables to an equal height.

It's very important that both tables match in height as close as possible and are leveled for a smooth connection process.

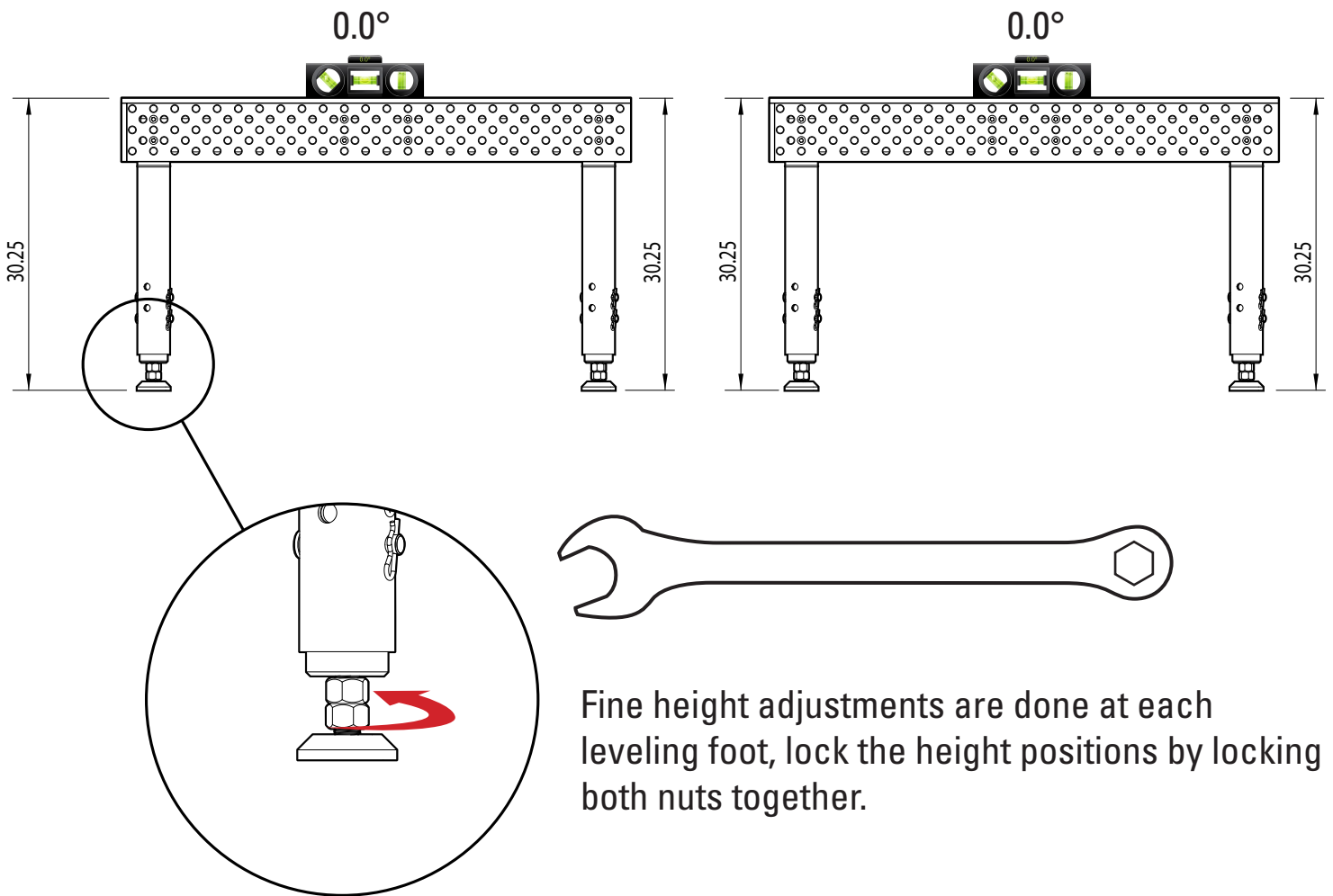

Fine height adjustments are done at each leveling foot, lock the height positions by locking both nuts together.



Alignment

After adjusting both tables to equal heights, place both tables next to each other and align them together by using four straight edge stops, riser blocks may also be used for this step. Next, connect one end of the stop to each end of the connecting tables as show in the diagram below. In this example we will use **T50510 Straight Edge Stops** along with **T55057 Universal Ball Lock Bolts**

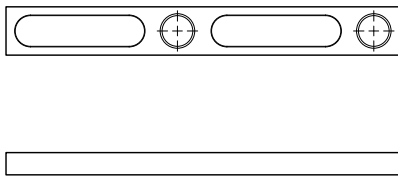

T50510 Straight Edge Stops



T55057 Universal Ball Lock Bolts

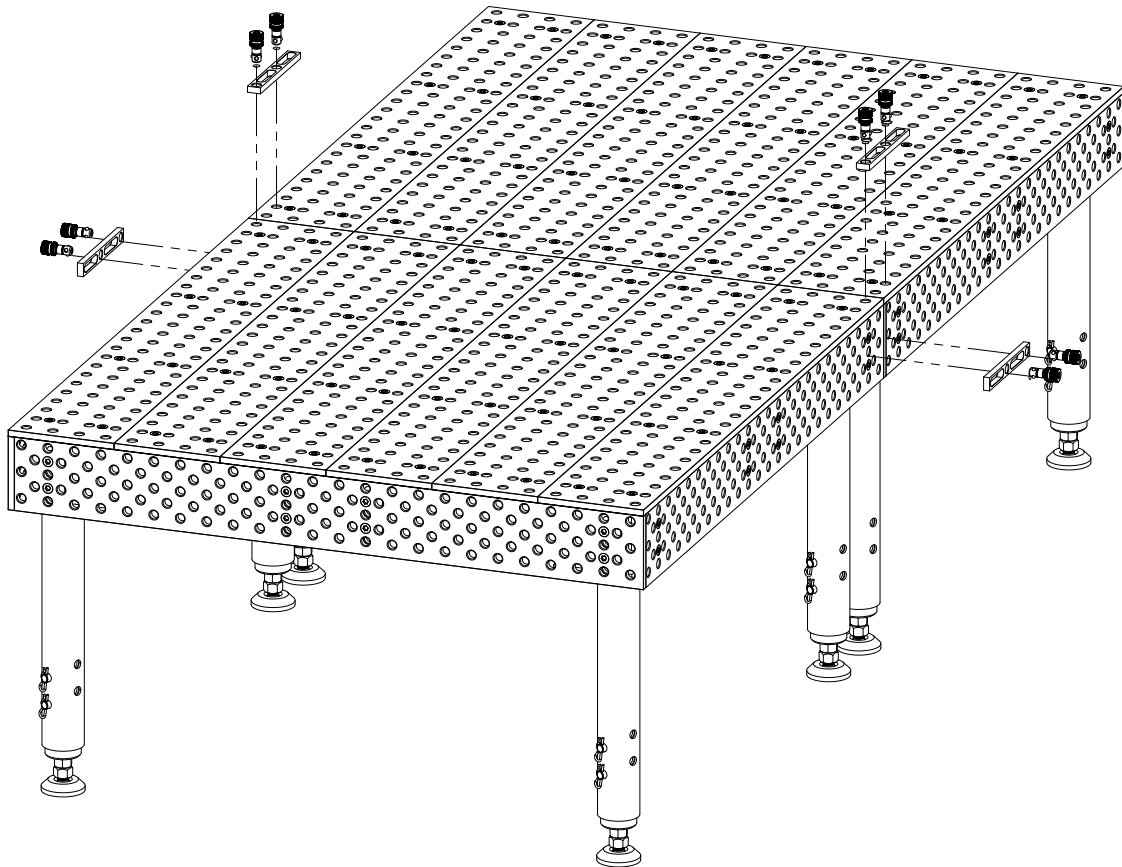



Connecting

After both tables have been aligned; connect them by using four **T832608 Flush mount Connecting Bolts**, insert them from the underside of the table as shown below.

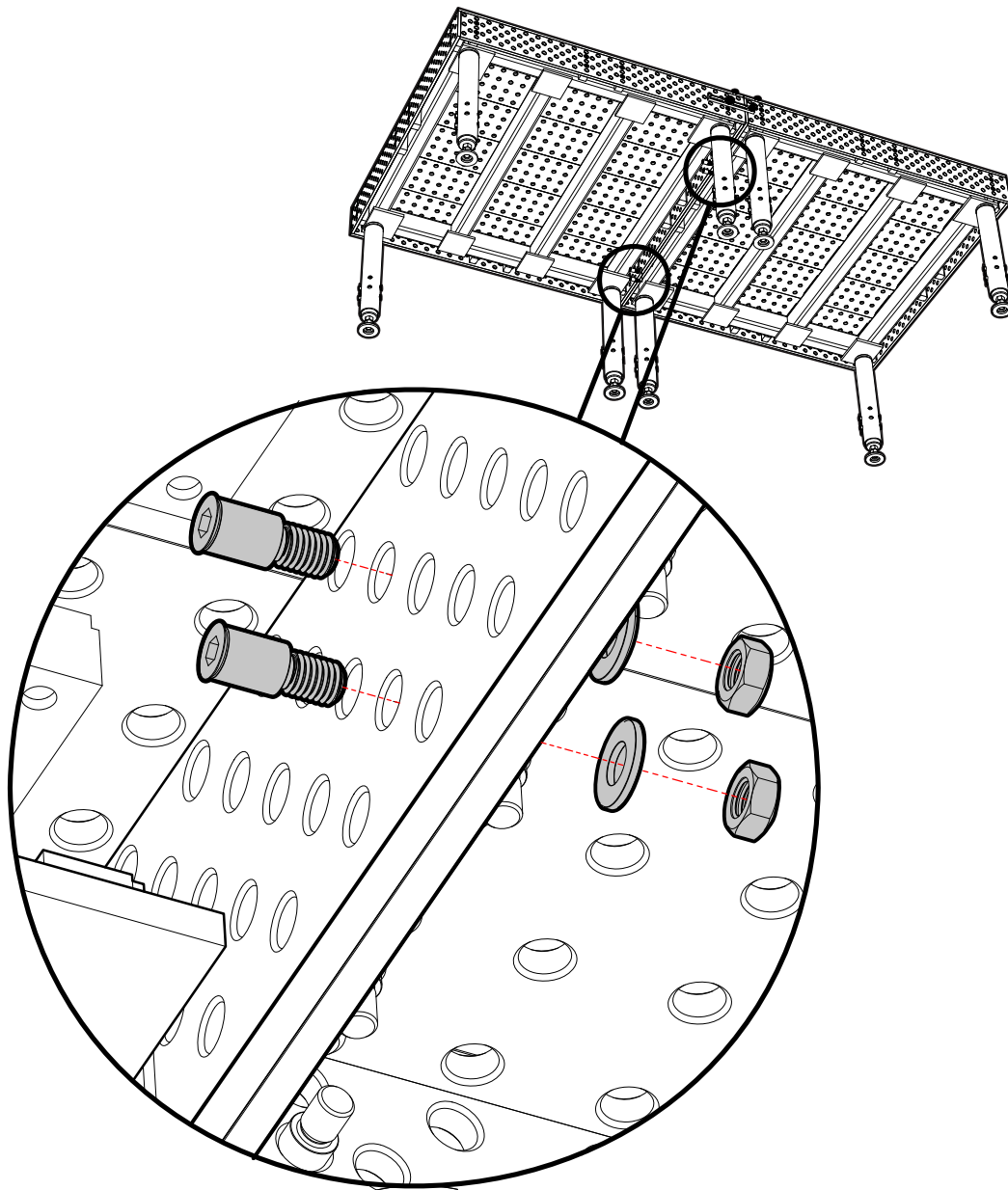

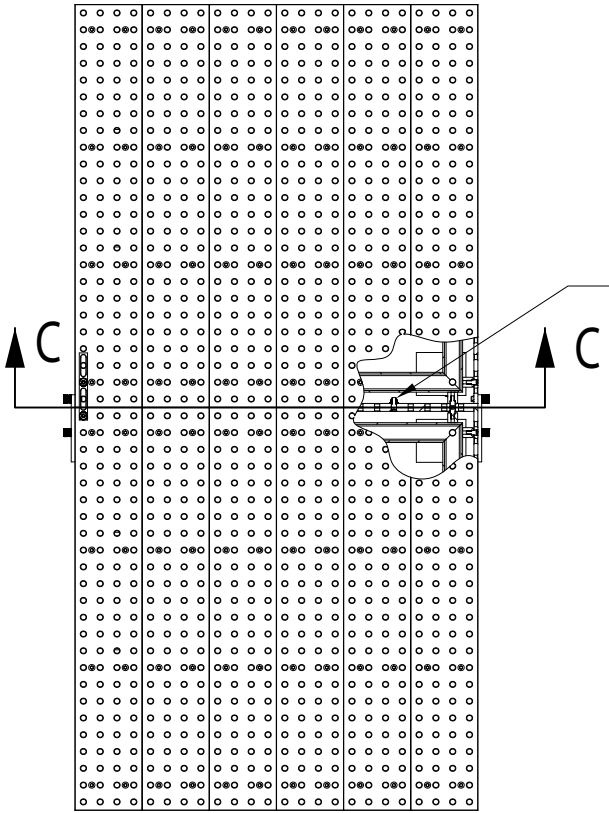

Recommended placement of connecting bolts

T832608 (X4)

