



NSS7, NSS8 and NSS12 Installation Guide

ENGLISH



www.simrad-yachting.com

Preface

As Navico is continuously improving this product, we retain the right to make changes to the product at any time which may not be reflected in this version of the manual. Please contact your nearest distributor if you require any further assistance.

It is the owner's sole responsibility to install and use the instrument and transducers in a manner that will not cause accidents, personal injury or property damage. The user of this product is solely responsible for observing safe boating practices.

NAVICO HOLDING AS AND ITS SUBSIDIARIES, BRANCHES AND AFFILIATES DISCLAIM ALL LIABILITY FOR ANY USE OF THIS PRODUCT IN A WAY THAT MAY CAUSE ACCIDENTS, DAMAGE OR THAT MAY VIOLATE THE LAW.

Governing Language: This statement, any instruction manuals, user guides and other information relating to the product (Documentation) may be translated to, or has been translated from, another language (Translation). In the event of any conflict between any

Translation of the Documentation, the English language version of the Documentation will be the official version of the Documentation.

This manual represents the product as at the time of printing. Navico Holding AS and its subsidiaries, branches and affiliates reserve the right to make changes to specifications without notice.

Copyright

Copyright © 2011 Navico Holding AS.

Warranty

The warranty card is supplied as a separate document.

In case of any queries, refer to the brand web site of your display or system:

www.simrad-yachting.com

Declarations and conformance

This equipment is intended for use in international waters as well as coastal sea areas administered by countries of the E.U. and E.E.A.

Compliance Statements

The Simrad NSS complies with the following regulations:

- FCC Part 15
- CE compliant per EN60945
- C - Tick

For more information please refer to our website:

www.simrad-yachting.com.

Warning

The user is cautioned that any changes or modifications not expressly approved by the party responsible for compliance could void the user's authority to operate the equipment.

This equipment has been tested and found to comply with the limits for a Class B digital device, pursuant to Part 15 of the FCC rules. These limits are designed to provide reasonable protection against harmful interference in a residential installation. This equipment generates, uses and can radiate radio frequency energy and, if not installed and used in accordance with the instructions, may cause harmful interference to radio communications. However, there is no guarantee that the interference will not occur in a particular installation. If this equipment does cause harmful interference to radio or television reception, which can be determined by turning the equipment off and on, the user is encouraged to try to correct the interference by one or more of the following

measures:

Reorient or relocate the receiving antenna

- Increase the separation between the equipment and receiver
- Connect the equipment into an outlet on a circuit different from that of the receiver
- Consult the dealer or an experienced technician for help

About this manual

This manual is a reference guide for installing the Simrad NSS systems.

The manual assumes that the user has basic knowledge of navigation, nautical terminology and practices.

The manual does not cover basic background information about how equipment such as radars, echo sounders and AIS work. Such information is available from our web site:

www.simrad-yachting.com/en/Support/Library/.

Important text that requires special attention from the reader is emphasized as follows:

→ **Note:** Used to draw the reader's attention to a comment or some important information.



Warning: Used when it is necessary to warn personnel that they should proceed carefully to prevent risk of injury and/or damage to equipment/personnel.

Contents

7	NSS overview
8	Front - Controls
9	Rear - Connectors
10	NSS7/NSS8 typical system example
11	NSS12 potential system example
12	Planning the installation
12	Preparing for installation
13	Check the contents
14	Mounting location
15	Mounting the NSS display
15	Panel mount
16	Bracket mount
17	Wiring the NSS
17	Wiring guidelines
18	Connecting power
18	Power connection (basic)
18	Power Control (yellow wire)
19	Power Control setup
20	External alarm
20	External Alarm Setup
21	External GPS
21	Mounting location
22	Internal echosounder
22	External echosounder
23	Transducer adapter cables
24	Echosounder setup
26	RADAR
27	HD radar
28	Radar setup
30	Video In
30	Connecting video sources
30	Video In configuration
31	NMEA0183
31	Wiring NMEA 0183 for RS422
31	Wiring NMEA 0183 for RS232
32	Serial port setup
33	NMEA2000 / SimNet
33	SimNet: The basics
34	Planning and installing a SimNet backbone
34	Power the SimNet network
37	Data bridging
38	NMEA 2000 / SimNet setup

39	Ethernet (NETWORK port)
39	Connecting directly to a single device
39	Connecting to multiple devices
41	Ethernet setup
42	Autopilot
42	Wiring the autopilot system
43	Using the SG05 EVC gateway
43	Autopilot setup
51	CZone connection to SimNet
52	CZone setup
53	Applying Software Updates
53	Backing up user data
53	NSS software updates
54	SimNet and Ethernet device updates
55	Dimensioned Drawings
55	NSS7
56	NSS8
57	NSS12
58	Connector Pinouts
58	Power
58	Video / Data
59	NMEA2000
59	Network (Ethernet)
59	Echosounder
60	Accessory cables
60	Simnet cables
60	Ethernet cables
61	Supported data
61	NMEA 2000 PGN List
64	NMEA0183 supported sentences
65	Specifications

NSS overview

NSS Sport Touchscreen multifunction display range includes three display sizes: 6.4" (VGA), 8.0" (SVGA), and 12" (XGA).

Ultrabright LED backlit screens are used across the range.

All three models include an internal GPS antenna.

The NSS12 features an internal ethernet switch with 3 ethernet connectors for extra network connectivity, whereas the NSS7 and NSS8 have built-in echosounders and a single ethernet connector.

Built-in Insight or Navionics coastal cartography (depending on region) with optional Platinum + Support via micro SD.

Network capability with Simrad NSE and NSO multifunction displays.

Expansion options include: Integration with AC12/AC42 and SG05 autopilot computers, external BSM-1, BSM-2, and LSS StructureScan echosounders, Broadband BR24, 3G, and HD Digital radar, SonicHub, SiriusXM™ Weather and Audio Support, SimNet/NMEA 2000, camera/video signal input, and BEP CZone integration.

Front - Controls

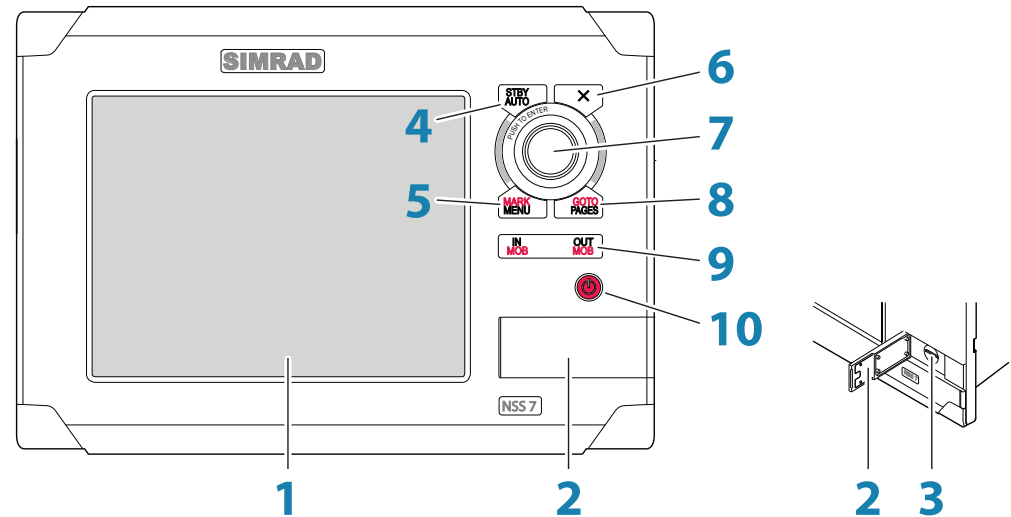

1 Touchscreen

2 Card reader door

3 Micro-SD Card reader

Used for optional Navionics or InsightHD chart data, software updates, transfer of user data and system backup.

4 STBY / AUTO key

Used for Autopilot operation.

5 MARK / MENU key

A short press displays the active panel's menu. A long press places a waypoint at the vessel's position.

6 X key

Used to exit dialogs, to return to previous menu level and to remove the cursor from the screen on chart, radar and echosounder panels.

7 Rotary knob

Used for zooming chart and for scrolling through menus. Press rotary knob to confirm selection.

8 GOTO / PAGES key

A short press displays the Pages overview panel (Home page). Repeated short presses toggles between Pages overview, Tools and Settings panels. A long press displays the Go To menu.

9 IN / OUT / MOB key Zoom key

for chart, radar and echosounder panels. A simultaneous press on both key ends will position a Man Over Board (MOB) mark at vessel's position.

10 Power key

A long press turns the unit ON/OFF. A short press brings up the light options dialog. Repeated short presses toggles between preset brightness levels.

Rear - Connectors

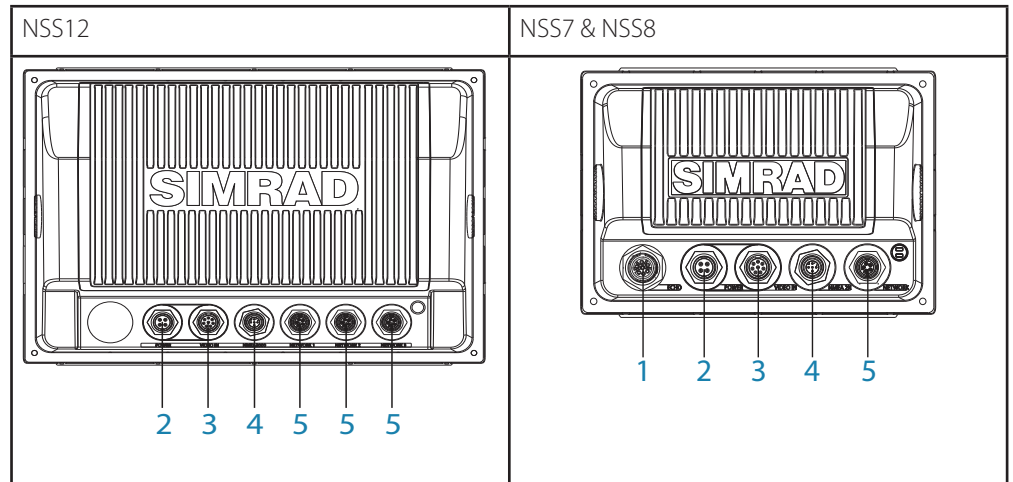

Key	Function	Description
1	ECHO	Built in Broadband Echosounder on the NSS7 and NSS8. NSS12 requires an optional echo sounder module connected via ethernet
2	POWER	For power input 12 or 24 V DC input (page 18), Power control (page 18) and external alarm (page 20).
3	VIDEO IN/ NMEA0183	Supplied cable provides two composite video inputs (page 30) and one RS422 port (NMEA0183 TX, RX) see NMEA0183 Wiring (page 31)
4	SIMNET/ NMEA2000	Connects NSS display to a SimNet or NMEA2000 network (see 'NMEA2000 / SimNet' on page 25).
5	NETWORK	Three Ethernet network ports on the NSS12 or one on the NSS7 and NSS8 for connecting to other NSS displays and Network modules. (see page 39)

The card reader door is opened by pulling outwards the right hand edge of the door.

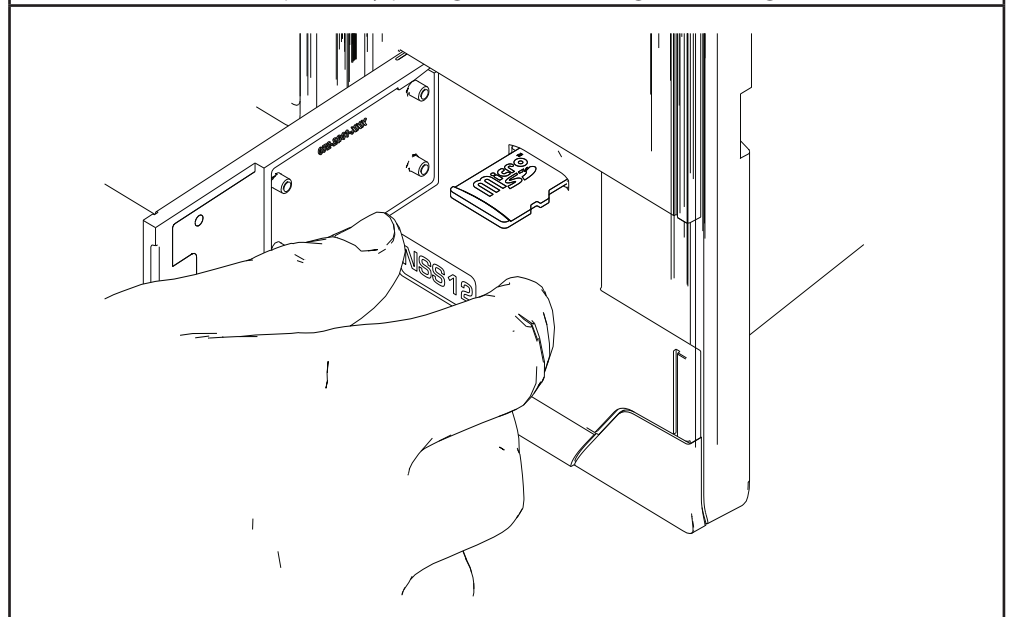

The card reader door should always be shut immediately after inserting or removing a card, in order to prevent possible water ingress.

NSS7/NSS8 typical system example

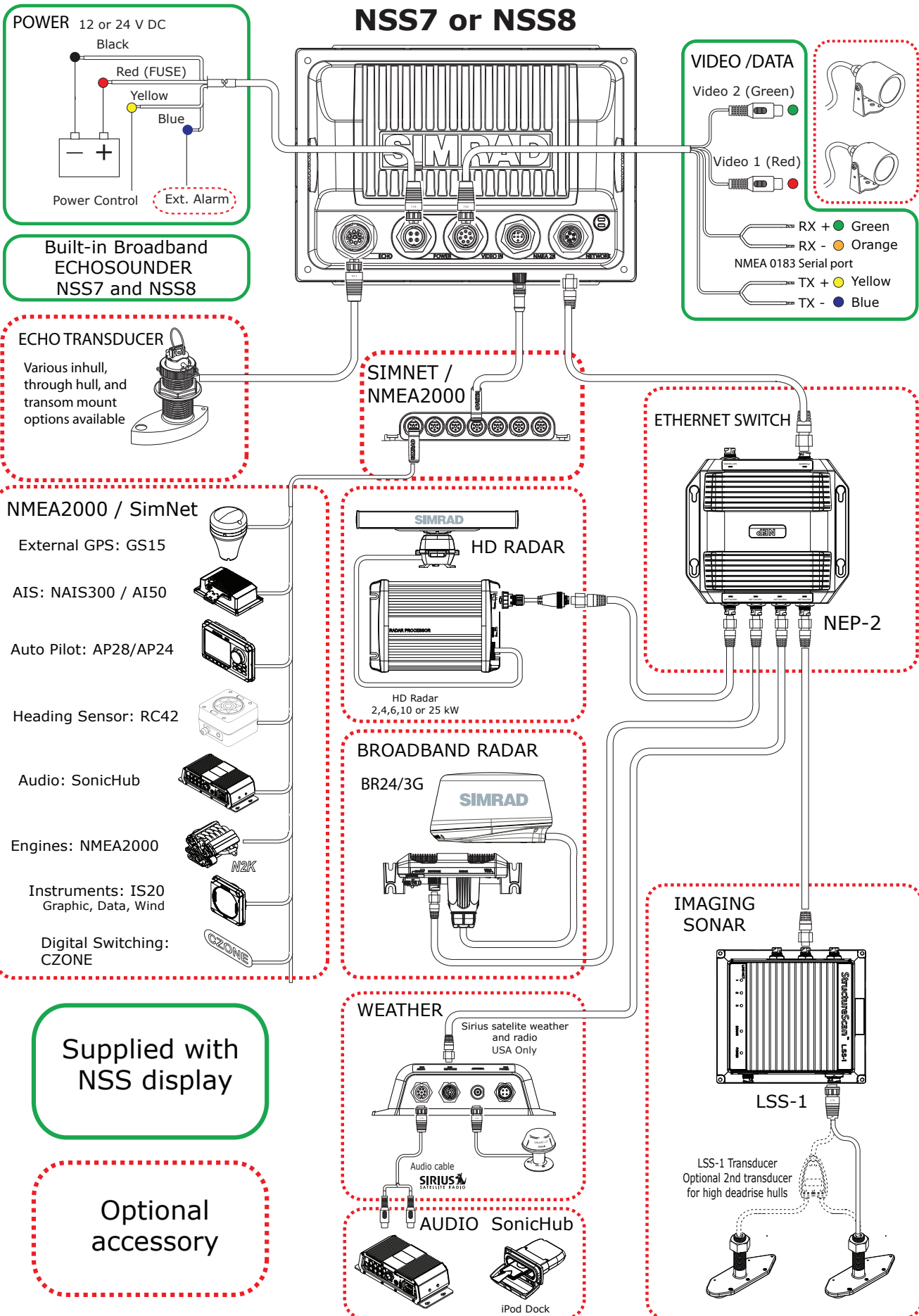

NSS12 potential system example

NSS12

NSS12

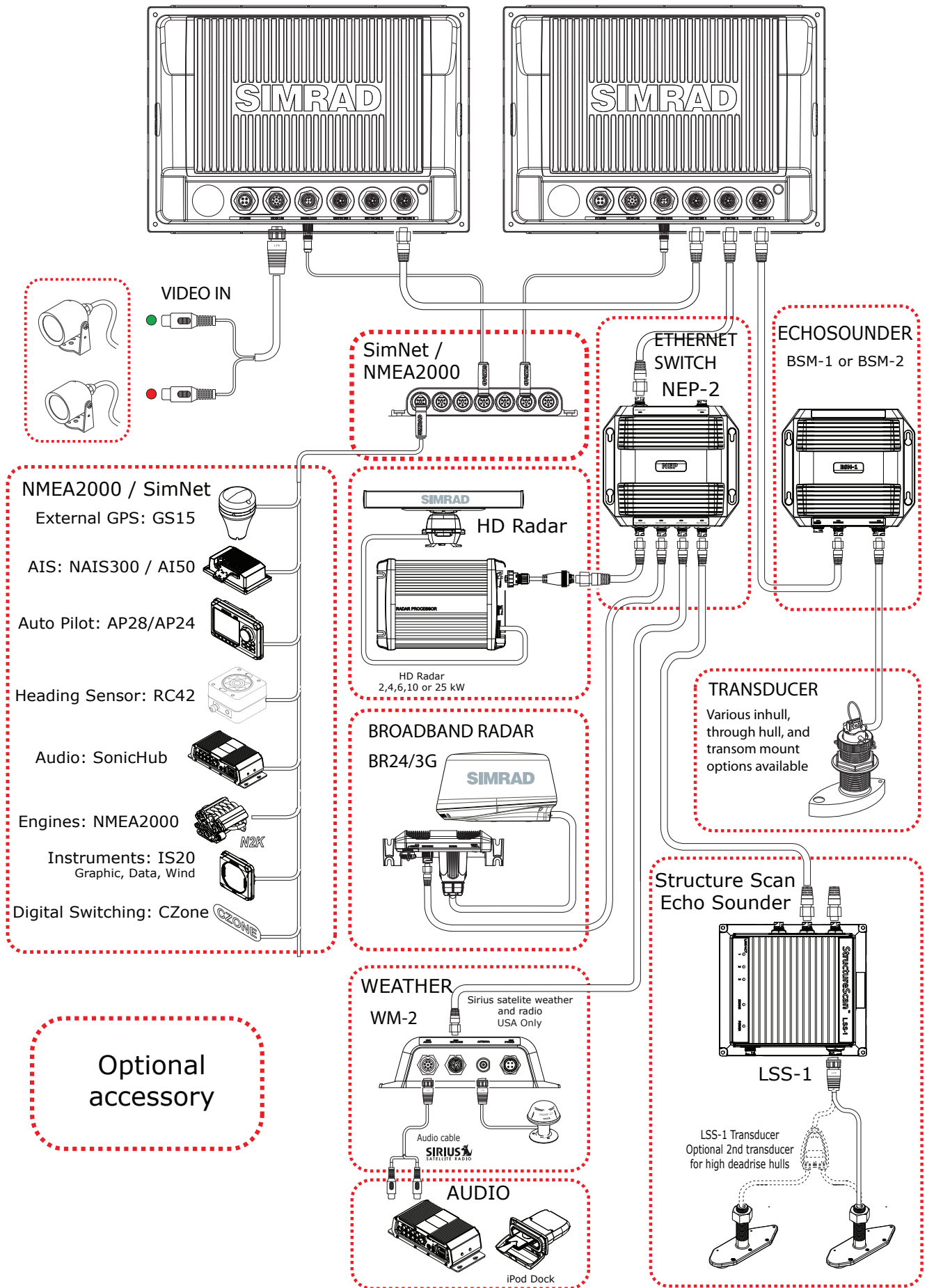

1

Planning the installation

Preparing for installation

Tools required

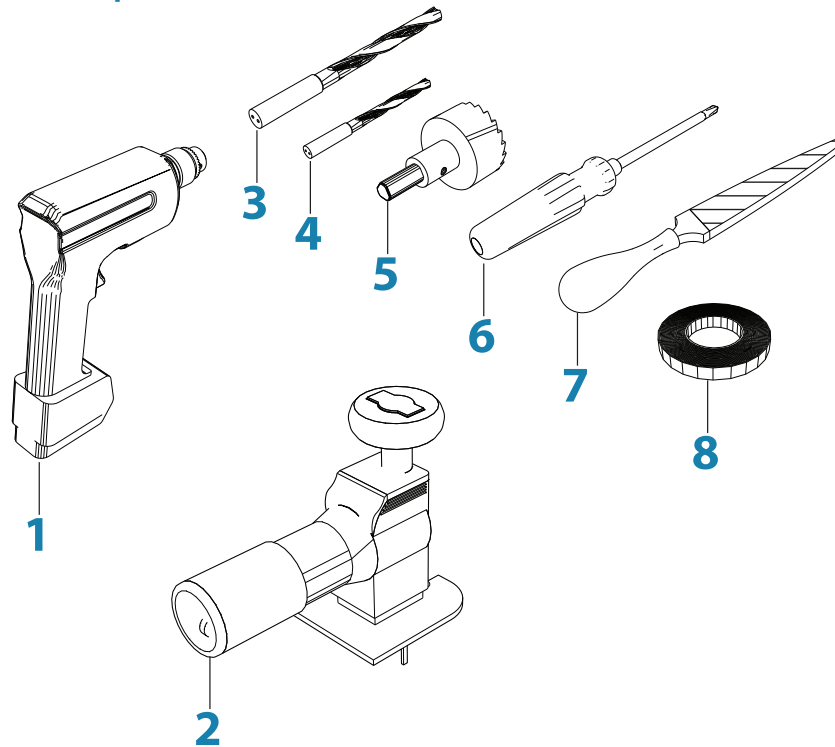

- 1 Drill
- 2 Jig Saw
- 3 Drill Bit
- 4 Drill Bit
- 5 Hole Saw (25mm / 1")
- 6 Pozi Screw Driver
- 7 File
- 8 PVC Electrical Tape

Check the contents

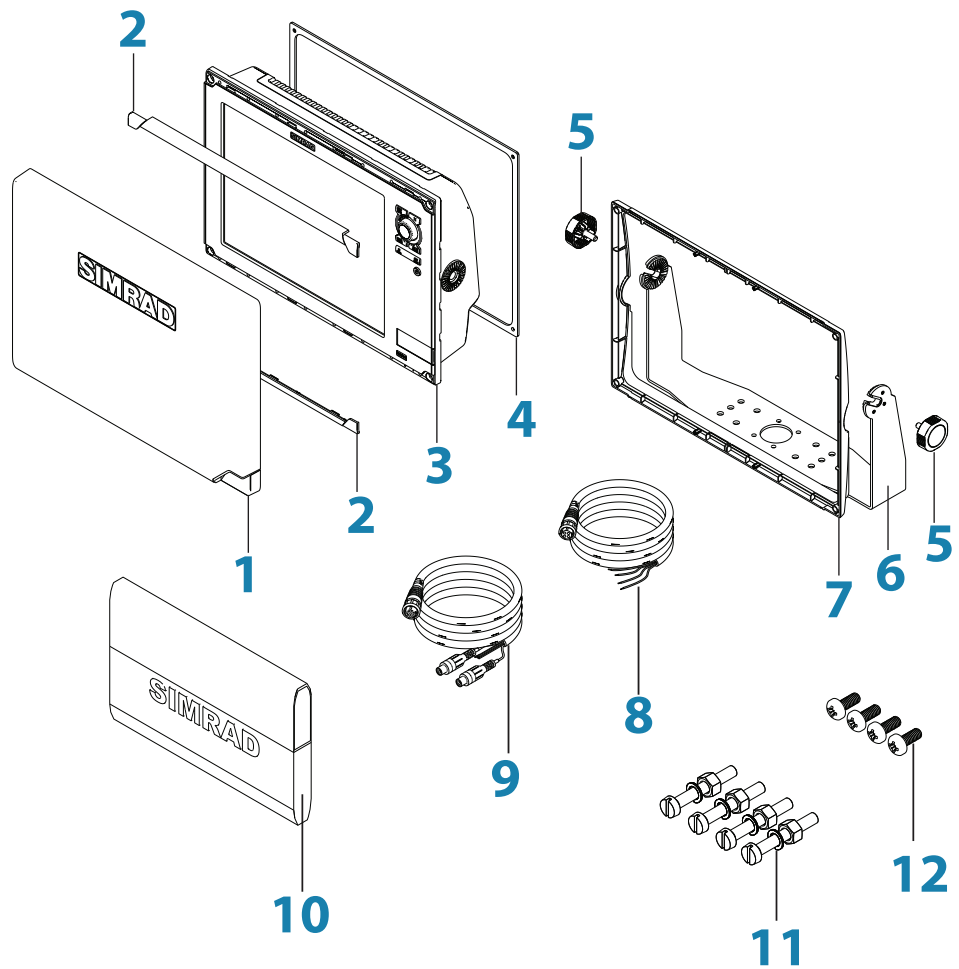

Key	Description	Key	Description
1	Sun Cover	7	Bracket mount rear bezel
2	Cosmetic screw covers (x2)	8	Power cable
3	NSS Display	9	Video/NMEA0183 cable
4	Flush mount gasget	10	Documentation wallet
5	Bracket knobs (x2)	11	Flush mount machine screws (x4)
6	Mounting bracket	12	Bracket mount rear bezel securing screws (x4)

Mounting location

Choose the mounting locations carefully before you drill or cut. The display should be mounted so that the operator can easily use the controls and clearly see the display screen. Be sure to leave a direct path for all of the cables. Simrad displays are high-contrast and anti-reflective, and are viewable in direct sunlight, but for best results install the display out of direct sunlight. The chosen location should have minimal glare from windows or bright objects.

Ensure that any holes cut are in a safe position and will not weaken the boat's structure. If in doubt, consult a qualified boat builder.

Before cutting a hole in a panel, make sure that there are no hidden electrical wires or other parts behind the panel.

Do not mount any part where it can be used as a hand hold, where it might be submerged, or where it will interfere with the operation, launching or retrieving of the boat.

If bracket mounting the display choose an area where the display will not be subjected to excessive vibration.

The mounting location will affect the internal GPS receiver. Ensure you test the unit in its intended location to ensure satisfactory reception. An external GPS source may be added to overcome poor reception areas.

Leave sufficient clearance space to connect all relevant cables.

Good ventilation is required. Poor ventilation may cause the display to overheat.

Simrad displays are designed to operate in temperatures from -15°C to $+55^{\circ}\text{C}$ ($+5^{\circ}\text{F}$ to $+131^{\circ}\text{F}$).

For overall width and height requirements, please see the dimensions section on page 55.

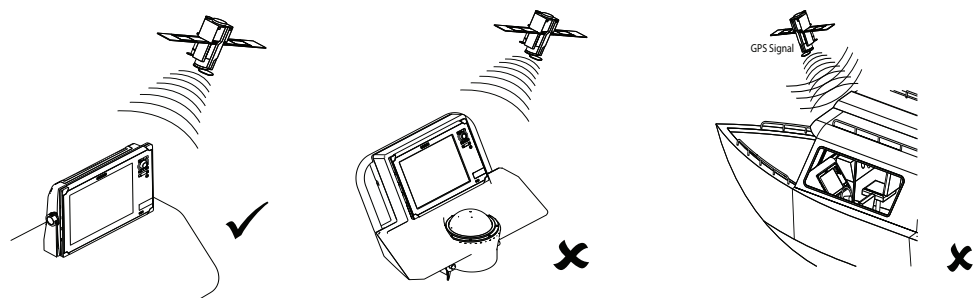
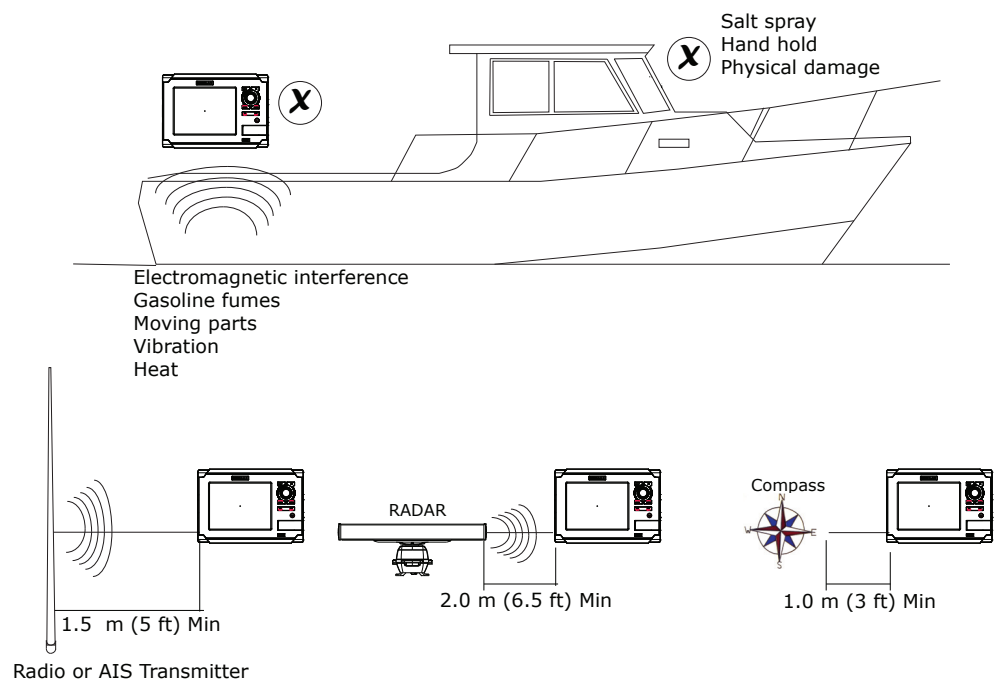

2

Mounting the NSS display

Panel mount

Attach the flush mounting template to the selected mounting position using adhesive tape.

Drill pilot holes for the four hole saw cuts and four self tapping screws used to secure the display. If using M4 machine screws use a 5 mm (0.20") drill bit.

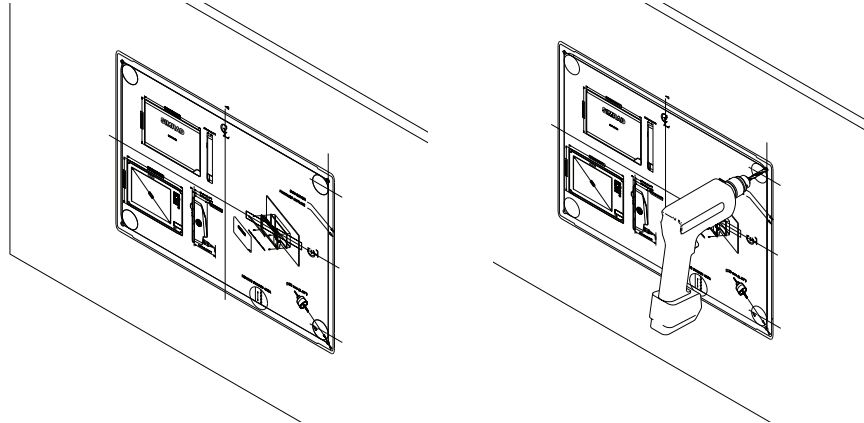

Use a 25 mm (1") hole saw to cut the four corner radius.

Cut along the dotted line and remove the shaded area.

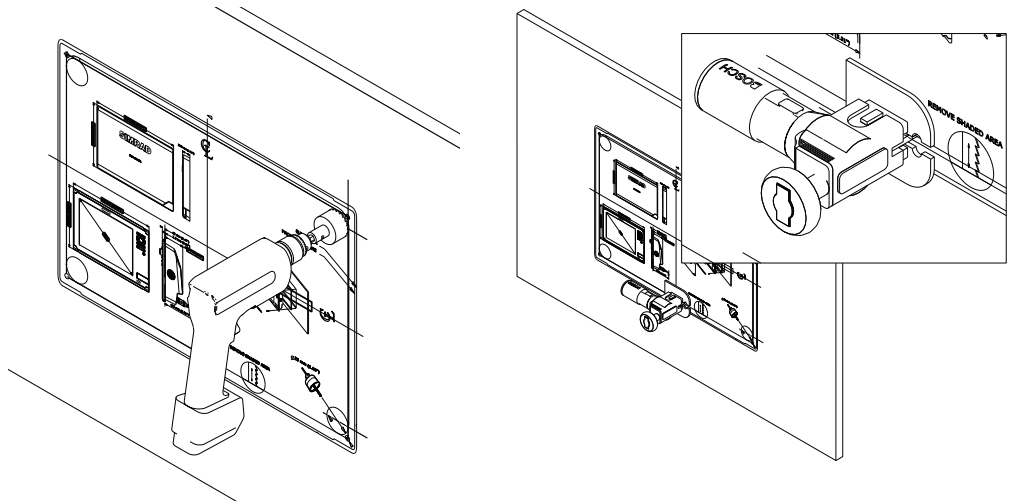

Peel backing off the gasket and apply to the surface.

Connect all cables to the rear of the unit before placing the unit into the console.

Secure the display to the surface.

To finish off the installation, firmly clip the upper and lower bezels in place.

Note: For flush installations the supplied rear bezel is not used.

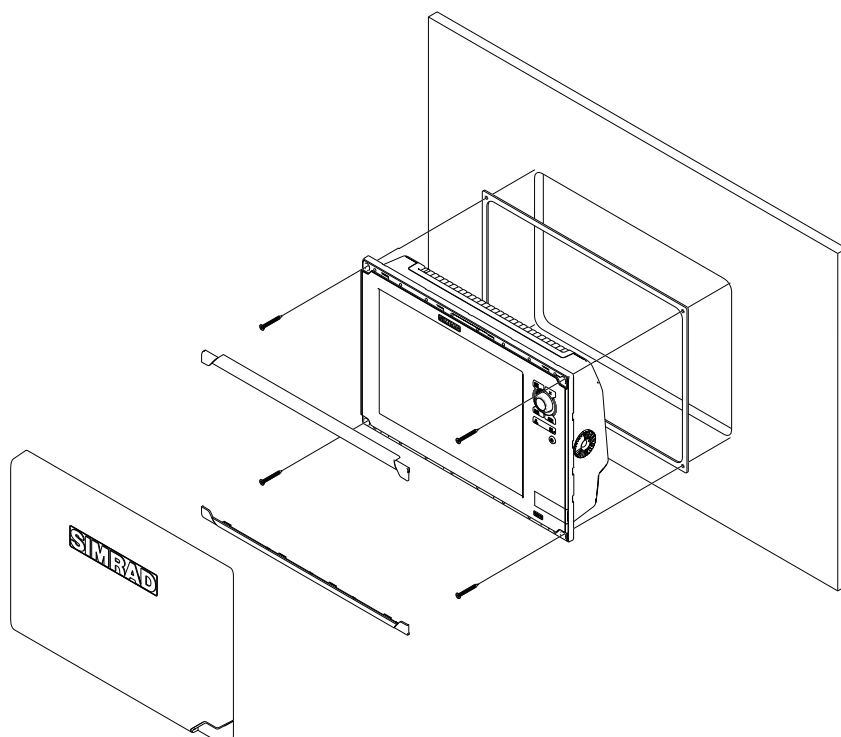

Bracket mount

Using the bracket as a template, mark places to drill the central cable hole and four pilot holes for the bracket fasteners.

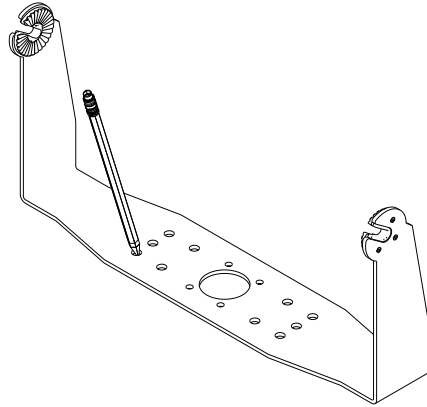

Drill cable and fastener pilot holes.

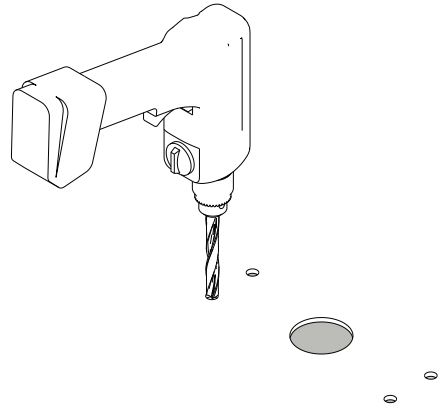

screw bracket down with fasteners.

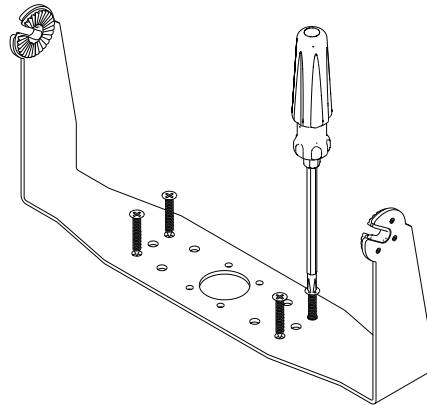

Fit rear bezel to NSS using supplied machine screws.

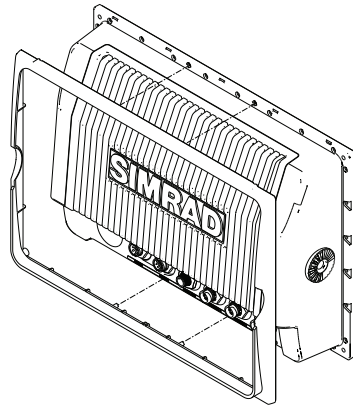

Align the NSS ratchet teeth with those of the bracket and partially screw in the bracket knobs one at a time.

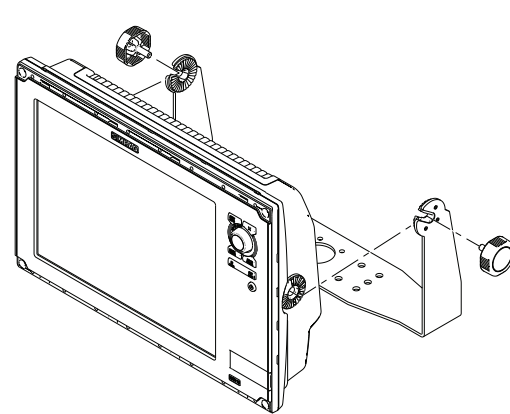

Further tighten both knobs to ensure the unit is held securely and can't tilt forward under its own weight.

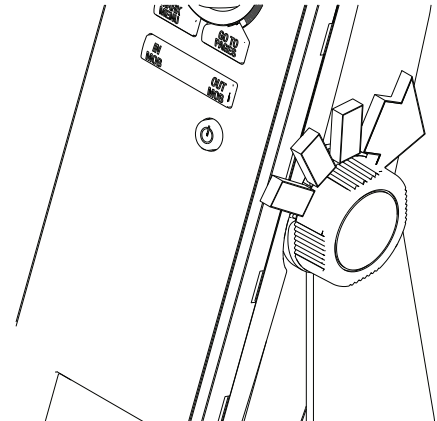

Stand back and check if the viewing angle is correct. Loosen the knobs slightly if adjustment is required, then re-tighten.

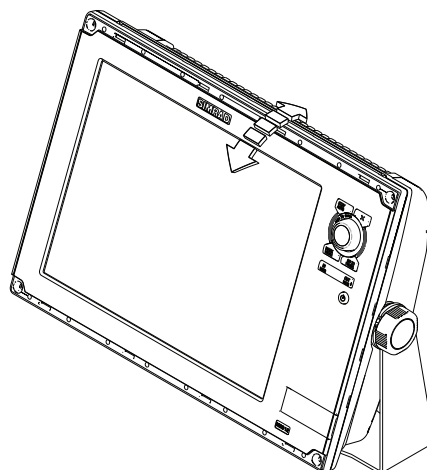

To finish off the installation, clip the upper and lower bezels in place.

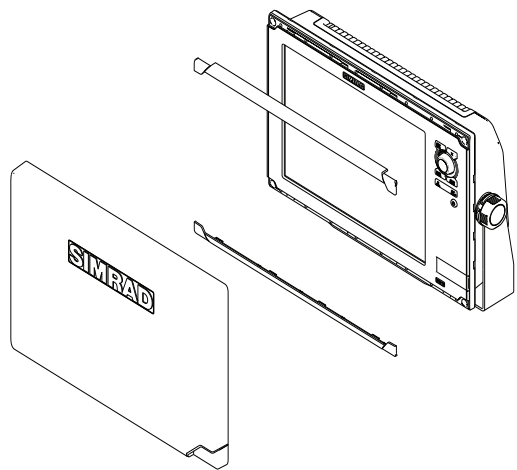

3

Wiring the NSS

Wiring guidelines

Don't do this	Do this
Don't make sharp bends in the cables	Do make drip and service loops
Don't run cables in a way that allows water to flow down into the connectors	Do tie-wrap all cables to keep them secure
Don't route the data cables in areas adjacent to radar, transmitter, or large current carrying cables	If cables are shortened, lengthened, or re-terminated, do insulate and protect all wiring connections
	Do leave room at the back to install and remove cables

⚠ Warning: Before starting the installation, be sure to turn electrical power off. If power is left on or turned on during the installation, fire, electrical shock, or other serious injury may occur. Be sure that the voltage of the power supply is compatible with the NSS display

⚠ Warning: The NSS has a voltage rating of 12 V DC or 24 V DC. (9 V DC - 32 V DC max range). SimNet is 12 V DC only

⚠ Warning: The red wire should always be connected to (+) DC V using a fuse or thermal breaker (10 Amp)

4

Connecting power

Power connection (basic)

The NSS display can be powered by either 12 V or 24 V DC. Displays are protected against reverse polarity, under voltage and over voltage.

The supplied power cable has a four core cable used for:

- power into the system (Red and Black wires)
- controlling power state of the display or power state of other displays and devices (Yellow wire)
- connecting to an external alarm (Blue wire)

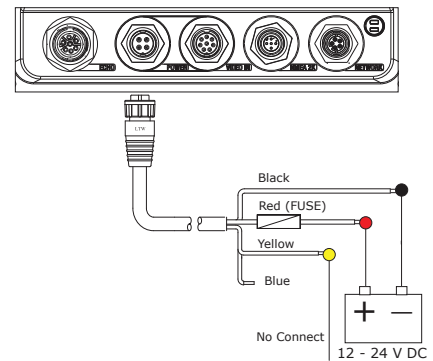

Connect red to (+) DC using a 5 amp fuse for NSS12, and a 3 amp fuse for NSS7 and NSS8. Connect Black to (-) DC. The display can be powered on and off using the power button.

Power Control (yellow wire)

Planning is required how you want to be able to turn on and off the NSS an connected compatible devices.

The yellow (Power Control) wire on the NSS power cable can either be an input that will turn on the display when power is applied, or an output that turns on other devices when the display is powered on. It can be configured at the installation stage to control the power state of displays and compatible devices. When commissioning the system, displays can be set to be a Power Control Slave or Power Control Master.

Power Control configuration options of the NSS are:-

- use the Power button to turn on the display only: Yellow wire not connected
- display to turn on when power is applied to the display: Common red and yellow wires
- use the Power button to turn on the display and other displays and or compatible devices such as Broadband Radar: Yellow wire connected to a Power Control Bus. (Set one or more displays to be a Power Control Master)

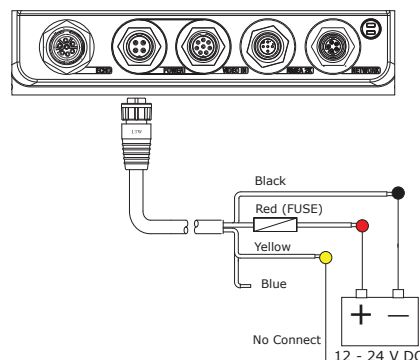

No Power Control

Yellow Wire: No Connect:

Display will turn on and off when the power button on the front of the unit is pressed. Power Control wire is not attached.

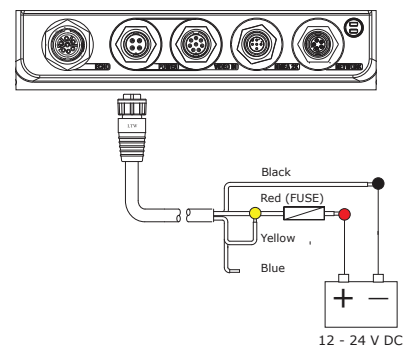

Auto Power on

Display will turn on when power is applied to the display. Common the yellow wire with the red wire after the fuse.

Note: The unit can not be powered down but can enter a standby mode. (screen back-light off).

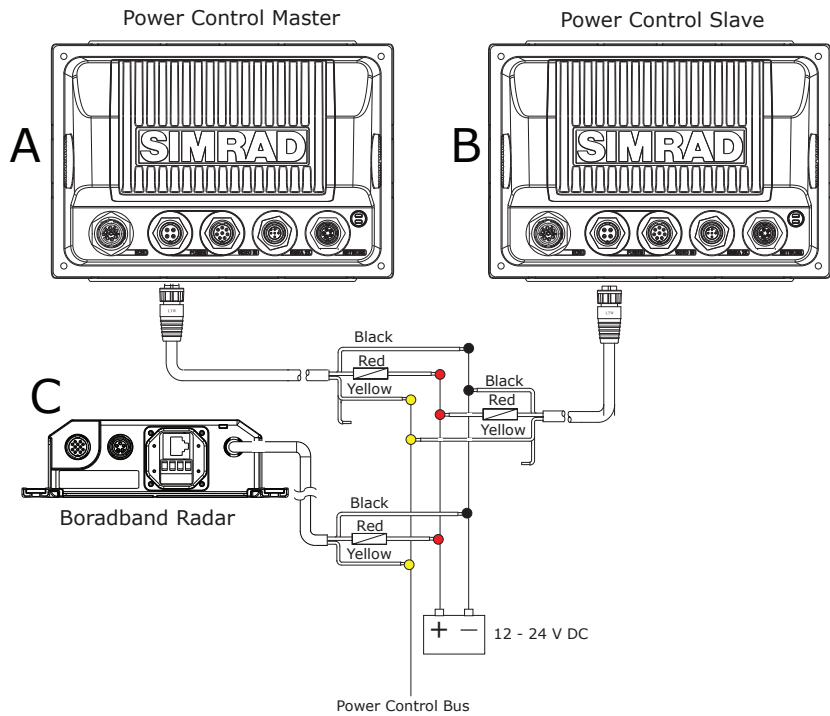

Power Control Master

Display (A) turns on using the power button. It is set as the Power Control Master and will output voltage on the Power Control bus to turn on display (B) and Broadband radar (C).

Display (B) is set to Power Control Slave and if turned on by display (A) cannot be powered down using its own power button, but can be set to standby.

If display (A) is off, display (B) can be turned on using its power button, but won't turn on any other devices. Display (B) could, however also be set to Power Control Master.

➔ **Note:** If a display has its power state controlled by another display or ignition switch, it can't be totally powered down. It can enter a standby state to save power. If the power button is pressed and Power Off selected, a message will appear "Preparing to standby..."



Power Control setup

To configure a display as a Power Control Slave or Master select Power control from the 'Settings' menu.

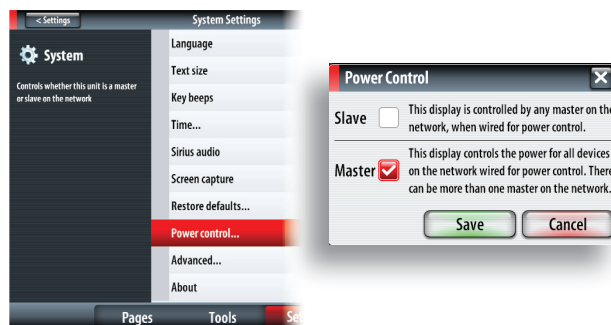

The following Simrad products require (+) DC Volts on the yellow wire in order to function: NEP-2, BSM-1, BSM-2, WM-2, Broadband radar, RI10, SonicHub.

The +DC volts can come via a switch, a breaker or from an NSS or NSE display yellow wire.

Not connected	Fused + DC power supply	Switch	NSS, NSE display yellow wire
Unit is turned on using the power key	Unit always on when power is on	Unit power controlled by switch	Unit turned on or off by display (if display power control master)

External alarm

Blue wire on power cable:

An external alarm can be connected to one or more displays on the network. The external alarm can be a small peizo buzzer connected directly, or a horn siren connected via a relay.

Alarms are configured globally in the system i.e they can be configured on one display and seen, heard and acknowledged from all displays. How ever the external alarm siren can be enabled or disabled on individual displays. For information on configuring alarms, refer to the Alarms section in the Operation manual.

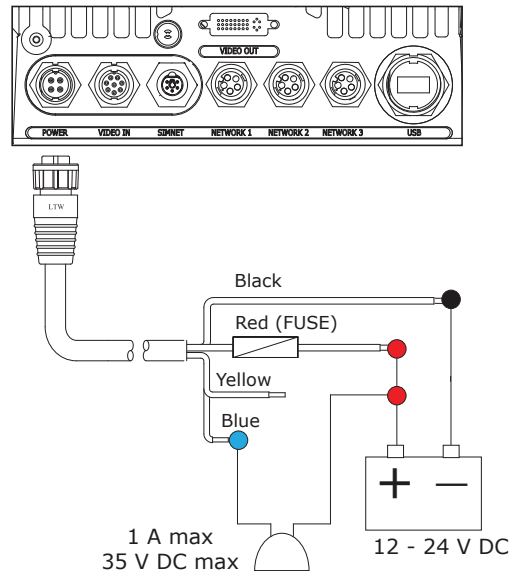

For sirens that draw more than 1 Amp use a relay

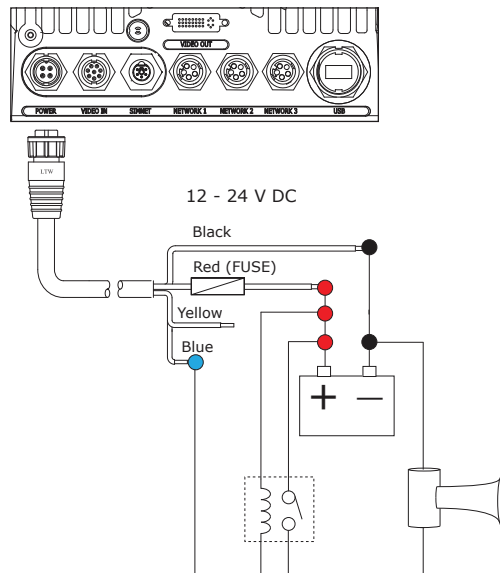

External Alarm Setup

The SIREN ENABLED option must be set in order for the unit to drive the external alarm when an alarm condition arises.

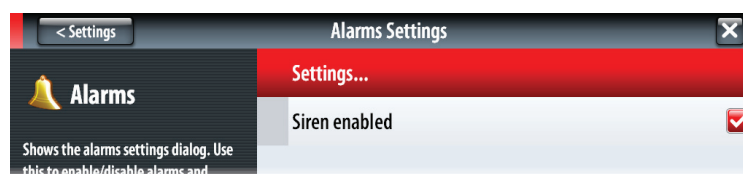

5

External GPS

Mounting location

Depending on vessel design and materials, certain mounting locations chosen for the NSS may not offer adequate GPS satellite signal reception using the internal receiver. An External GPS source such as the GS15 can be used to overcome this, by allowing remote installation in a location that has an unobscured view of the sky.

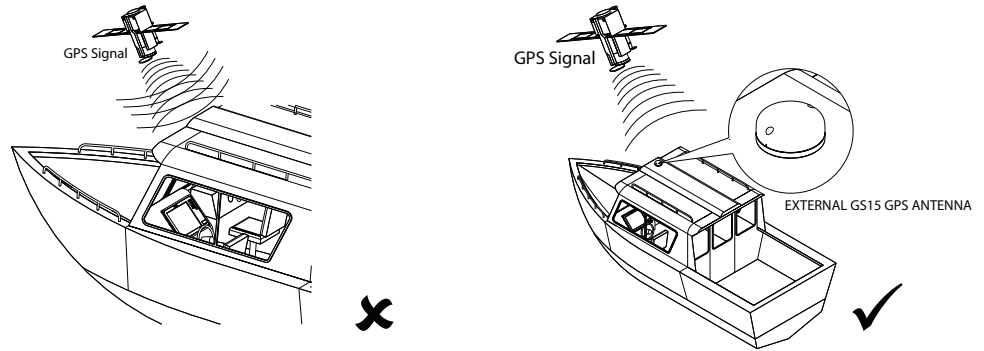

Parts required for external GPS

000-0125-25 GS15 GPS Antenna

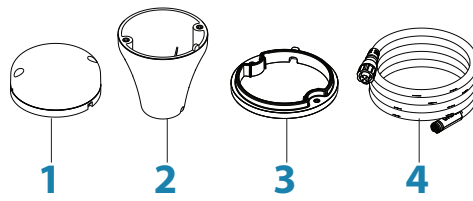

- 1 GS15 Antenna
- 2 Pole mount
- 3 Surface mount gasket
- 4 Micro-C to SimNet cable 4 m (13 ft)

SIMKIT-1: SimNet Starter Kit

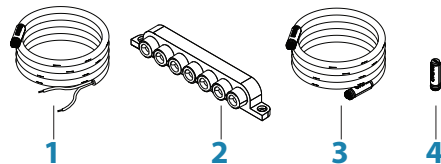

- 1 SimNet Power cable
- 2 SimNet 7 way Joiner
- 3 SimNet cable
- 4 SimNet Terminator

→ **Note:** Refer to chapter 11 NMEA2000/SimNet for further details on connecting to SimNet.

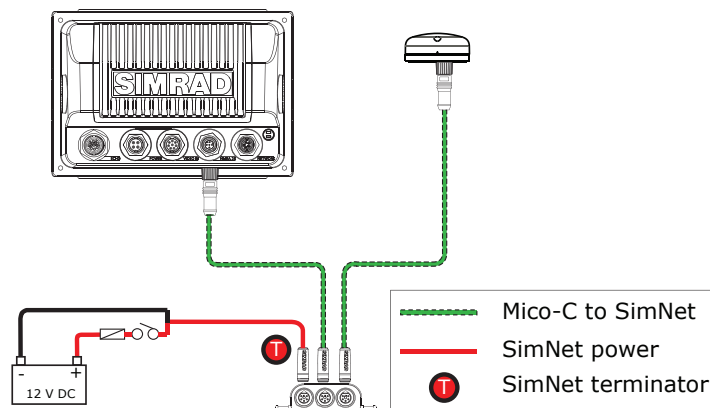

For setting the external GPS as position source, refer to "NMEA 2000 / SimNet setup" on page 38.

6

Echosounder

Internal echosounder

The NSS7 and NSS8 have an Internal Broadband Echosounder. Navico transducers fitted with the 7 pin blue connector can be plugged directly into the corresponding blue socket adjacent to the power connector.

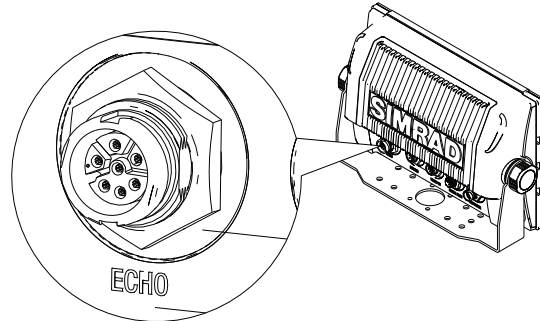

External echosounder

An optional external sounder module (BSM-1, LSS-1, BSM-2) can be added to the NSS7, NSS8 and NSS12 via the ethernet port on any of these devices.

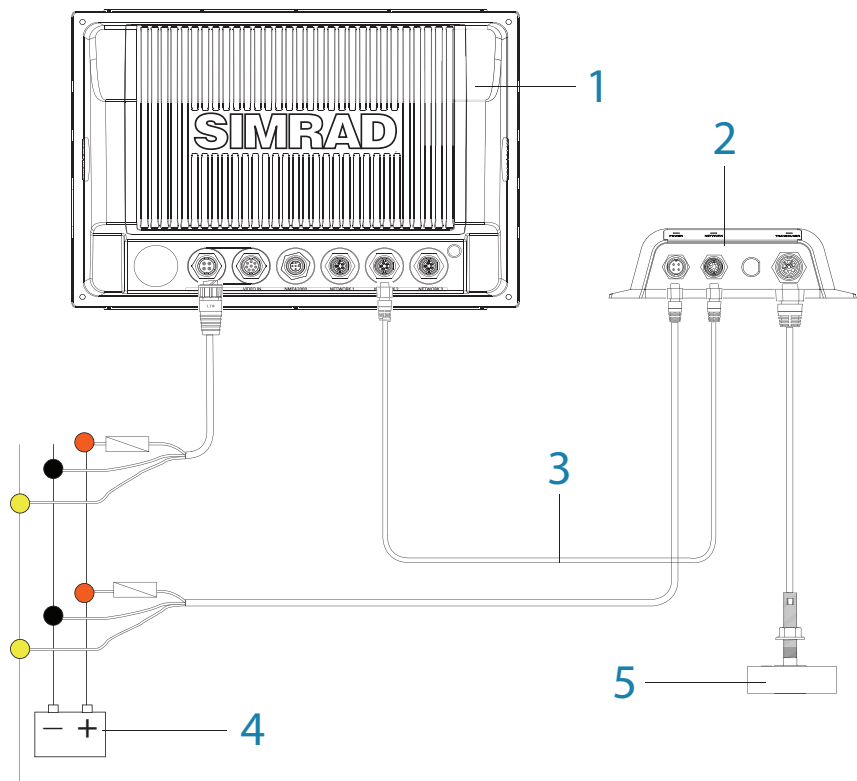

- 1 NSS display
- 2 BSM-1 Broadband Echosounder module
- 3 Ethernet cable yellow 5 pin See page 58 for more cable length options. Cable can be connected directly to NSS or via a Network Expansion Port
- 4 12 or 24 V DC
- 5 Transducer

Transducer adapter cables

For vessels with existing transducers that do not have the Navico blue 7 pin connector, there are two adapter cables available to assist with installation.

For vessels that already have a transducer that was used with older Navico products that has 6 pin connector. Use 000-00022-001 6 pin to 7 pin transducer adapter cable.

These transducers will require the 10 k temp version of the transducer selected for transducer type in Echo Installation. See the Echosounder Setup section on page 69 for further information.

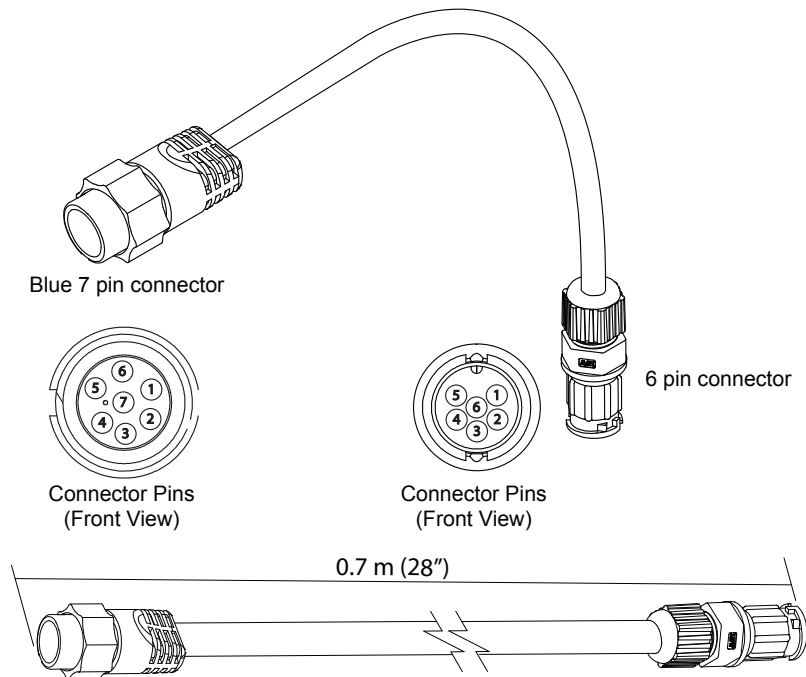

For other transducers that do not have Navico blue 7 Pin or 6 pin (above) connector that require the connector to be removed. Use 000-10046-001 7 pin to bare wire adapter cable. Not all transducers are compatible with NSS or BSM-1. Refer to the transducer type selection list in the Echo Installation page to see if your transducer is mentioned for the selected echo source. If not contact your Simrad dealer or Simrad Technical Support for assistance with transducer compatibility. Simrad always recommends using Simrad transducers.

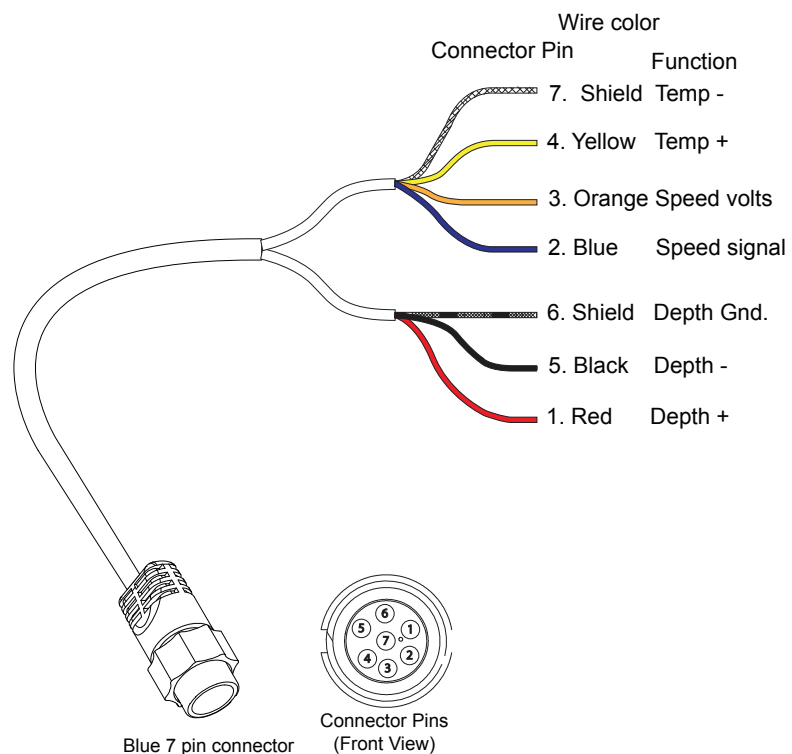

Echosounder setup

Select echosounder source

Choose the Echosounder source in the Echo Settings . MENU > MENU > ECHO.

This can be selected to be the echosounder built in to the display (NSS7 and NSS8 only), or an external sounder module such as the BSM-1.

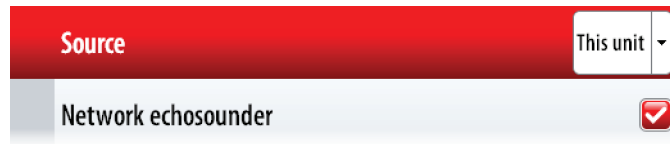

Deselecting the Network Echosounder option, limits source selection to internal sonar only.

Depth offset

This is a value that can be entered on the Echo Installation page to make depth readings relate to any point from the water surface, to the deepest point of the vessel.

Below are some typical ways in which the offset is used:

A) For Depth below Keel: Set the distance from transducer to the keel.

Enter a negative value, e.g.

B) For Depth Below Transducer: no offset required.

C) For Depth Below Surface (waterline): Set the distance from transducer to the surface:

Enter a positive value, e.g.

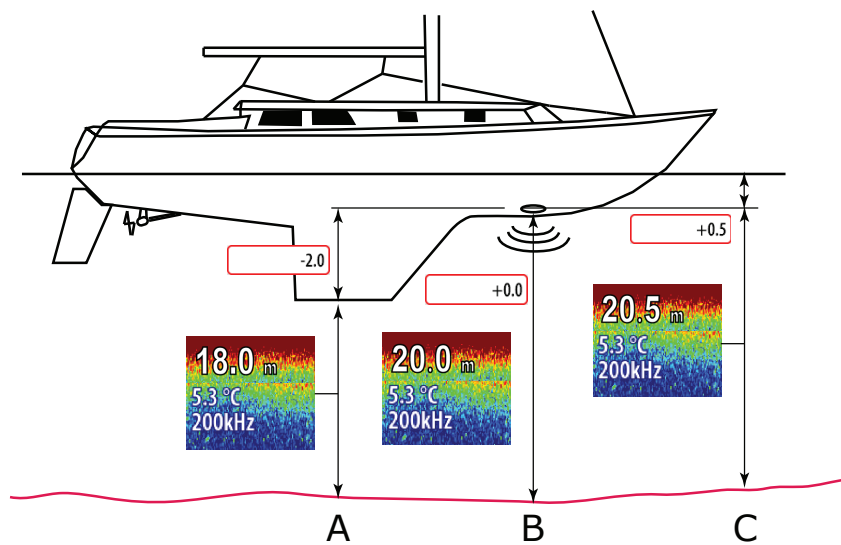

Echosounder software version	A screenshot of the 'Echo Installation - BSM-1 v1.2.0' software window. It shows a 'Depth offset (m)' field with a red box around the value '+1.0'.
For external sounder modules, the software version is displayed under Sonar installation. To upgrade Sonar software See 'Applying Software Updates' on page 53	

Water speed calibration (Echosounder transducer)

Water speed calibration is used to adjust the speed value from the paddle wheel to match the actual boat speed through the water. Actual speed can be determined from GPS speed over ground (SOG) or by timing the boat over a known distance. Water speed calibration should be performed in calm conditions, with minimal wind and current movement.

Select Auto correct to match water speed to ground speed (SOG).

Manual calculation. Increase this value above 100% if the paddle wheel is under reading, and decrease this value if it is overreading, e.g. if the average water speed reads 8.5 knots and SOG records 10 knots the calibration value needs to be increased to 117%. To calculate the adjust-

ment, divide the SOG by the paddlewheel speed, and multiply the product by 100.
Calibration range: 50-100%. Default is 100%.

Water speed averaging (echosounder transducer)

Averages water speed by measuring your speed at a selected interval of time. Water speed intervals range from one to thirty seconds, e.g. If you select five seconds, your displayed water speed will be based on averaging over 5 seconds of sampling.

Calibration range: 1-30 seconds. Default is 1 second.

Water temperature calibration (echosounder transducer)

Temperature calibration is used to adjust the water temperature value from the echosounder transducer to match the data from another temperature sensor. It may be required to correct for localised influences to the measured temperature.

Calibration range: -9.9° - +9.9°. Default is 0°.

→ **Note:** Water temperature calibration only appears if the transducer is temperature capable. Check transducer type selection if this option should be available.

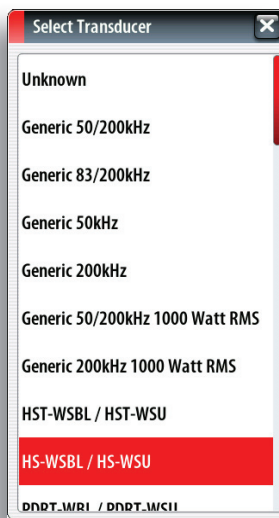

Transducer type

Transducer type is used for selecting the transducer model connected to the echosounder module. In some transducers with built-in temperature sensors, the temperature reading may be inaccurate if the wrong transducer is selected from the transducer type menu.

7

RADAR

Broadband radar (BR24 and 3G)

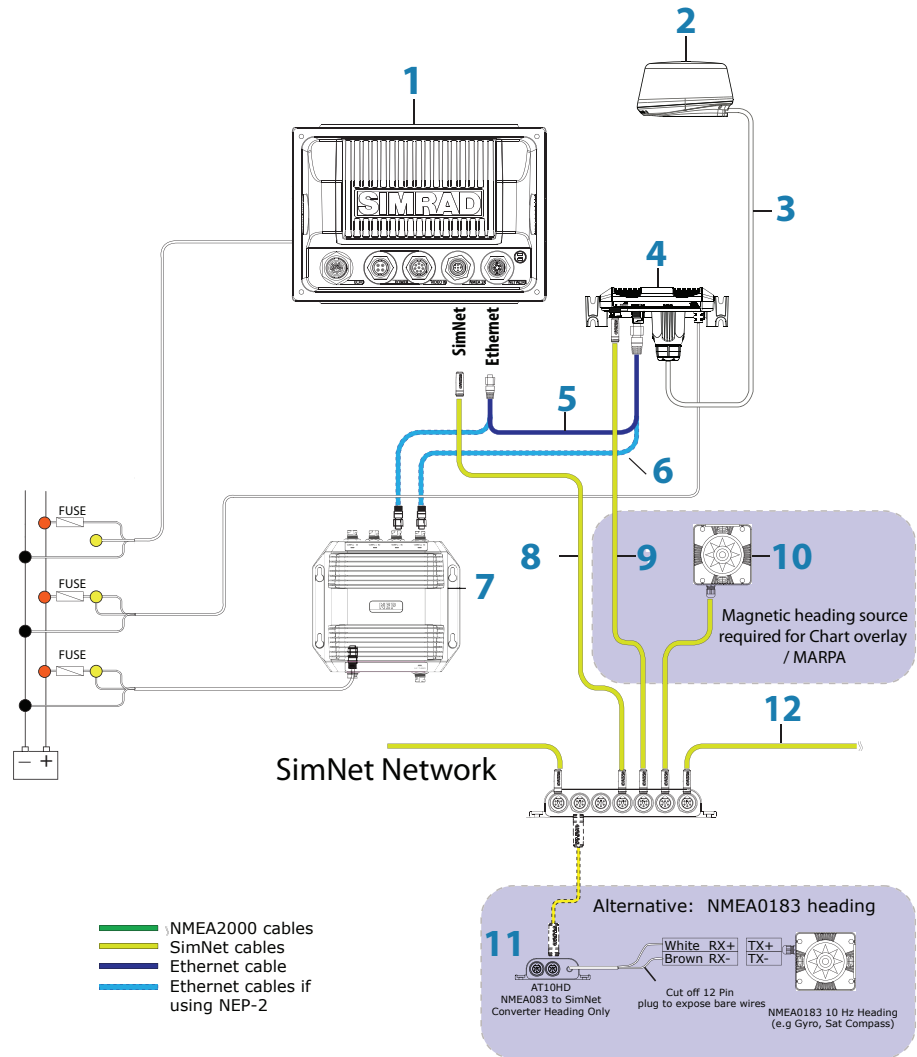

Key	Description	Notes
1	NSS display	
2	BroadBand™ Radar Scanner	
3	Interconnection cable	Standard 20 m (65 ft) cable. Optional lengths: 10 m (33 ft) and 30 m (98 ft)
4	RI10 Radar interface box	
5	Ethernet cable	Radar supplied with a 1.8 m (6 ft) cable
6	Ethernet cables	Additional required to connect radar via a NEP-2
7	Ethernet expansion port NEP-2 (000-0132-031)	
8	SimNet to Micro-C cable	
9	SimNet drop cable.	Allows display to receive heading information for chart overlay and MARPA
10	RC42 Heading Sensor (22090195)	
11	AT10HD NMEA0183-SimNet	Converts NMEA0183 to SimNet / NMEA2000 (Only heading information is converted)
12	SimNet backbone	

HD radar

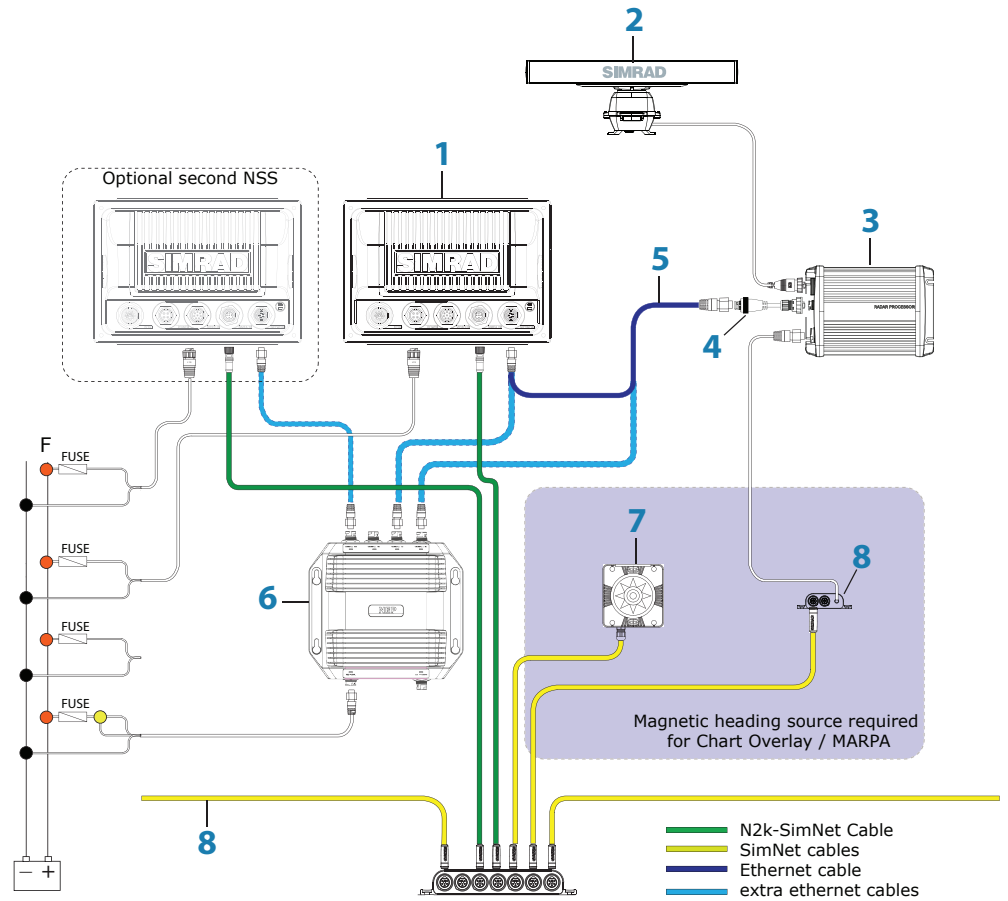

Key	Description
1	NSS Display
2	HD Radar Scanner
3	HD Radar Processor Module
4	Ethernet adaptor cable
5	Ethernet cable (Navico 5 pin type)
6	NEP-2 Expansion Port module (optional - used where extra ports are required)
7	RC42 rate compass
8	AT10HD (provides heading data to radar processor for radar overlay and MARPA)
9	SimNet cable

Radar setup

Setup and configuration of the Broadband radar has been simplified compared to traditional pulse radars. There is no zero range (time delay), no warm up time, and no burn-in required..



Radar status

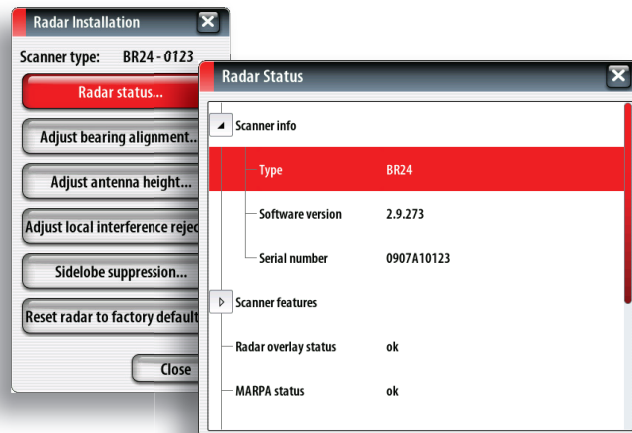

Scanner type

Identifies the model of scanner connected to the network.

Software version

Check to make sure you have the latest software. check website for the latest version.

Serial Number

This number should be recorded for support and insurance purposes.

MARPA status

The MARPA status can identify if a heading sensor is on the network and that the radar is receiving heading information essential for MARPA calculations.

Reset device ID

NSS displays only support one radar on the network. Should a radar be connected, that has been connected to a dual radar network in the past, it may not be detected by the display because it has an incorrect Device ID. With the radar connected and power up, select the Reset Device ID button to resolve this problem.

→ **Note:** This procedure must be performed with only one radar on the network.

Adjust bearing alignment

This is to align with the heading marker on the screen with the center line of the vessel, this will compensate for any slight misalignment of the scanner during installation. Any inaccuracy will be evident when using MARPA or chart overlay.

Point the boat to be perpendicular to the very end of a breakwater or peninsula. Adjust the bearing alignment setting, so that the heading marker and land mass intersect.

Adjust antenna height

Set the radar scanner height. The Radar uses this value to calculate the correct STC settings.

Adjust local interference reject

Interference from some onboard sources can interfere with the Broadband radar. One symptom of this could be a large target on the screen that remains in the same relative bearing even if the vessel changes direction. Choose from Local interference rejection LOW, MED or HIGH. Default is LOW

Sidelobe suppression

- **Note:** This control should only be adjusted by experienced radar users. Target loss in harbour environments may occur if this control is not adjusted correctly.

Occasionally false target returns can occur adjacent to strong target returns such as large ships or container ports. This occurs because not all of the transmitted radar energy can be focused into a single beam by the radar antenna, a small amount of energy is transmitted in other directions. This energy is referred to as sidelobe energy and occurs in all radar systems. The returns caused by sidelobes tend to appear as arcs:

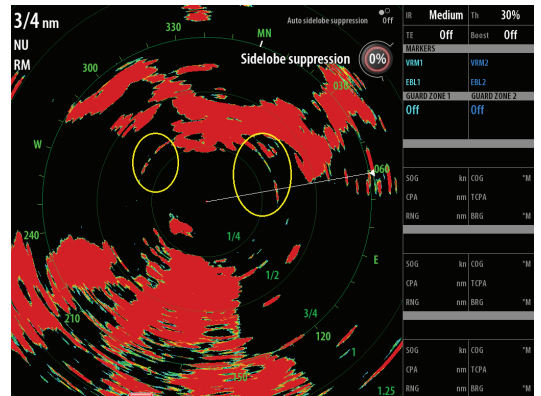

When the radar is mounted where there are metallic objects near the radar, sidelobe energy increases because the beam focus is degraded. The increased sidelobe returns can be eliminated using the Sidelobe Suppression control in the Radar installation menu.

By default this control is set to Auto and normally should not need to be adjusted. However if there is significant metallic clutter around the radar, sidelobe suppression may need to be increased. The control should be adjusted as follows:

1. Set Radar range to between 1/2 nm to 1 nm and Sidelobe Suppression to Auto.
2. Take the vessel to a location where sidelobe returns are likely to be seen. Typically this would be near a large ship, container port, or metal bridge
3. Traverse the area until the strongest sidelobe returns are seen.
4. Change Auto sidelobe suppression to OFF then select and adjust the sidelobe suppression control until the sidelobe returns are just eliminated. You may need to monitor 5-10 radar sweeps to be sure they have been eliminated.
5. Traverse the area again and readjust if sidelobes returns still occur.
6. Exit the installation menu.

Restore radar to Factory Default

This can be used to revert all user adjustments.

8

Video In

Connect up to two composite video cameras to each display unit using the supplied Video / Data cable. This connects to the VIDEO IN port on the rear of the display.

→ **Note:** The video images will not be shared with another NSS unit via the network. It is only possible to view video on the unit connected to the video source.



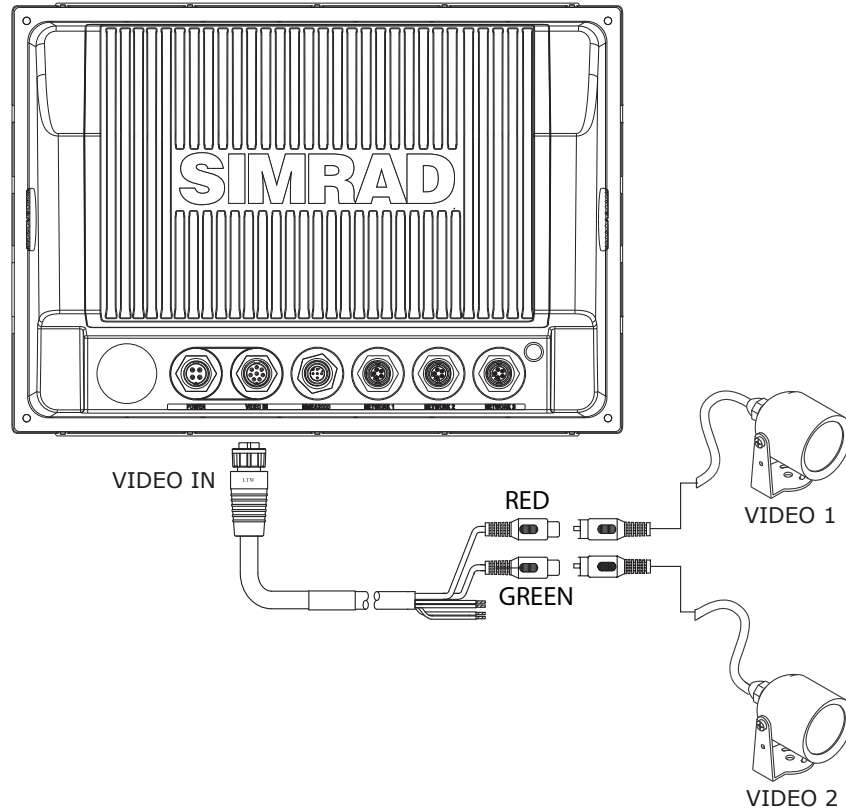

Connecting video sources



→ **note:** Only connect NTSC and PAL video sources

Video In configuration

Tapping the video panel will bring up the video panel buttons. Access the Video Menu by one of the following:

	<p>Press the MENU key</p>	
	<p>Tap the MENU icon in the video panel buttons</p>	
	<p>Press and hold on the video panel</p>	

Enable PAL or NTSC depending on the video output standard of the camera.

You can optimize the video display by adjusting the video image settings (brightness, saturation, etc.). The settings are adjusted individually for each video source.

9

NMEA0183

To exchange NMEA0183 data, the NSS display has a NMEA0183 serial port, providing both an input and an output.

The port uses the serial RS422 (balanced) and RS232 (single ended) standards and can be configured in the software for different baud rates, up to 38,400 baud. NMEA0183 sentences output by the NSS can be individually turned on or off.

Refer to NMEA0183 Supported Sentences on page 62 for a complete list of sentences.

Wiring NMEA 0183 for RS422

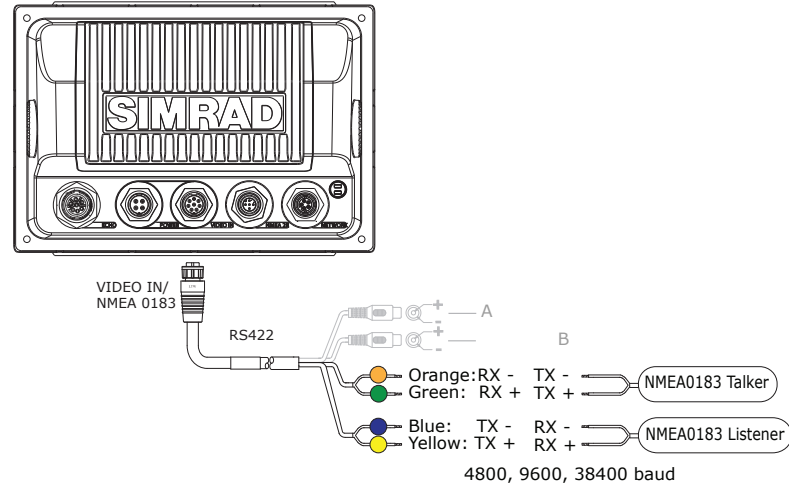

Wiring NMEA 0183 for RS232

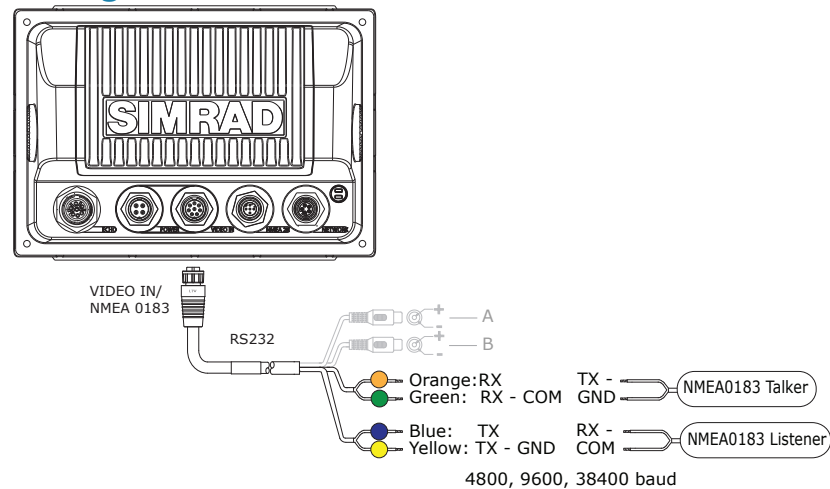

→ **note:** when connecting to a DB-9 plug for interfacing to a PC, combine Rx - COM, and TX - GND from the NSS, and connect to pin 5 (PC GND). Rx is connected to pin 3, Tx to pin 2.

Talkers and Listeners

Do not connect multiple devices outputting data (Talkers) on to the input (Rx) of the NSS. The RS422 protocol is not intended for this type of connection, and data will be corrupted if more than one device transmits simultaneously. The output however may drive multiple receivers (Listeners). The number of receivers is finite, and depends on the receiving hardware. Typically three devices is possible.



Serial port setup

NMEA 0183 setup is done from the Network Settings page.

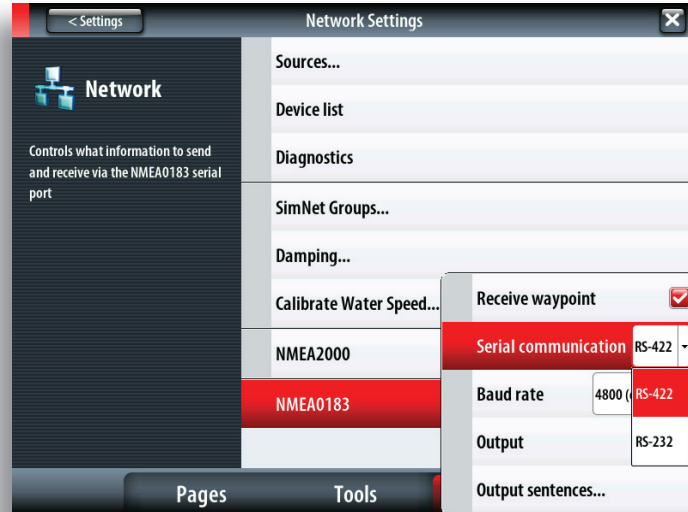

Receive waypoint

Select this option to allow device capable of creating and exporting waypoints via NMEA0183 to transfer directly to the NSS.

Serial communication

This should be set according to correspond with devices connected to the NMEA 0183 input and output. RS422 is the default setting.

Baud rate

Baud Rate is set simultaneously for the input and the output, it can not be set at a different speed for each. It should be set to match the speed of the device connected to it. Most NMEA 0183 devices send data at 4800 baud.

- ➔ **Note:** AIS transponders typically operate at NMEA0183-HS (high speed), and will require the baud rate to be set to 38,400.

NMEA0183 output

To enable data output, select the **Output** option, and then select which sentences the NSS needs to transmit to other devices from the **Output Sentences** list.

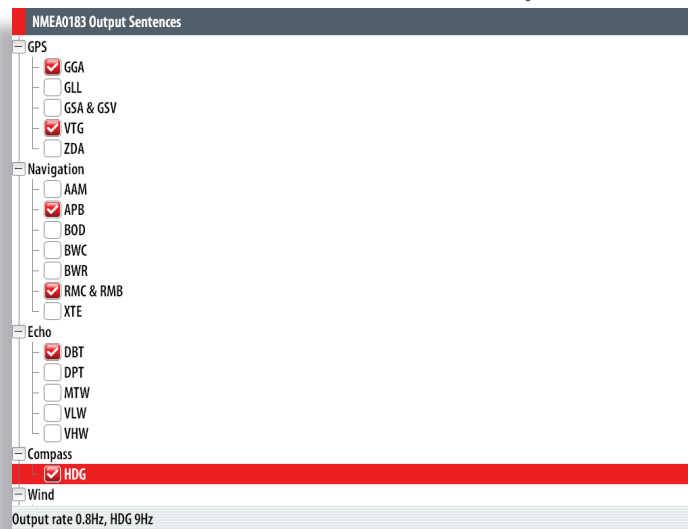

All NMEA0183 sentences are unchecked by default.

10

NMEA2000 / SimNet

NMEA 2000 is a combined electrical and data specification.

NMEA2000 and SimNet is a data network based on CAN (Control Area Network) bus technology that makes interconnection and integration of Simrad and other NMEA2000 products simple. NMEA2000 permits exchange of data and commands between the interfaced products. The data transfer capacity of SimNet is 50 times higher than that of the NMEA0183 standard at 4800 baud.

Certain NMEA0183 data can be converted to and from the SimNet network by;

- using the NSS display to bridge data (internally).
- using an optional external converter unit such as the Simrad AT10.
- using a third-party NMEA2000 to NMEA0183 bridge.

Most NMEA2000 devices can be connected directly to a SimNet backbone and SimNet devices can be connected to a NMEA2000 network by using adapter cables. (see 'Simnet Cables' on page 60)

Note: The NSS has a Micro-C NMEA2000 connector and is fully compatible to work in a SimNet network.

SimNet: The basics

- SimNet is Simrad's proprietary network based on NMEA2000 CAN bus (SAE J1939 protocol).
- SimNet is a powered network. It must have a separate 12-15 V DC power supply protected by a 5 Amp fuse. Do not connect the SimNet power cable to the same terminals as the start batteries, Autopilot Computer, Radar, thruster or other high current products.
- A SimNet network consists of a linear "backbone" from which "drop cables" to SimNet devices connect. Devices that have more than one SimNet connector can be part of a SimNet backbone (daisy chained) (But not as part of a NMEA2000 backbone).
- A drop cable is a SimNet cable that connects a SimNet device to the backbone. A drop cable has a maximum length of 6 m (20 ft).
- A SimNet Network has a maximum cable length of 120 m (394 ft), which includes drop cables + 30 m (98.5 ft) mast cable. Total 150 m (500 ft) max.
- A SimNet network needs to have a terminator at each end of the backbone. A terminator can be one of the following:
 - a power cable with built in terminator (red cap)
 - a terminator plug (red cap)
 - terminated in-line joiner (red locking collars)
 - a wind transducer (terminator is in the mast head unit as opposed to mast cable).
- Certain Simrad products have two SimNet connectors, which can be made to be part of the backbone. Connecting from device to device is known as 'daisy chaining' This network topology is not officially NMEA 2000 compliant.

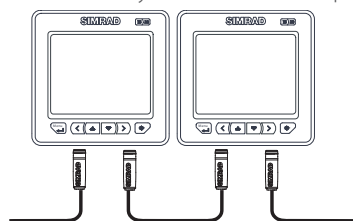

- NMEA2000 devices can be connected to the SimNet Network providing they:
 - are NMEA2000 certified
 - meet the CE, FCC regulations with a SimNet adapter cable
 - do not exceed the SimNet load specification (please refer to separate document Simrad SimNet Installation Manual (2022/2006))

Planning and installing a SimNet backbone

Plan the SimNet backbone carefully

Note: For part numbers refer to 'SimNet Accessories' page "Simnet Cables" on page 60

The SimNet backbone needs to run between the locations of all SimNet products you want to install, and be less than a 5.5 m (18 ft) cable run from a SimNet device.

Choose from the following components to make up your SimNet backbone:

- SimNet cables: 0.3 m (1 ft), 2 m (6,6 ft), 5 m (16.6 ft), and 10 m (33 ft) cables
- SimNet power cables with or without termination
- SimNet in-line joiner with or without termination
- T-Joiner. Use at locations where you want to connect a single SimNet device or join lengths of SimNet cable
- 7 way joiner. Use to connect up to 5 devices at one location
- Wind transducer. If using a wind sensor, plan to connect this to one end of the backbone as this has a terminator built in

Power the SimNet network

A SimNet network requires its own 12 V DC power supply protected by a 5 amp fuse or breaker. For 24 V use a DC-DC converter

Connect power at any location in the backbone for smaller systems using a SimNet power cable with termination (red cap).

For larger systems introduce power at central point in the backbone to "balance" the voltage drop of the network. Use SimNet cable without termination (yellow cap, part # 24005910). See diagram on page 36.

- **If** joining to an existing NMEA2000 network or similar CAN bus network that has it's own power supply, do not connect to another power supply.
- **Do** not connect the SimNet power cable to the same terminals as the start batteries, Autopilot Computer, Radar, thruster or other high current products

The drawing below shows a small SimNet network. Power is introduced at one end using a SimNet power cable with termination ending with a second terminator.

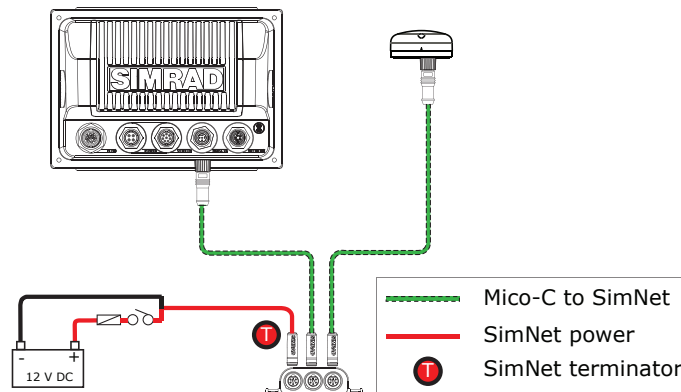

In the slightly larger system below, power is connected at one end using terminated power cable, and a second terminator is required at the end of the backbone.

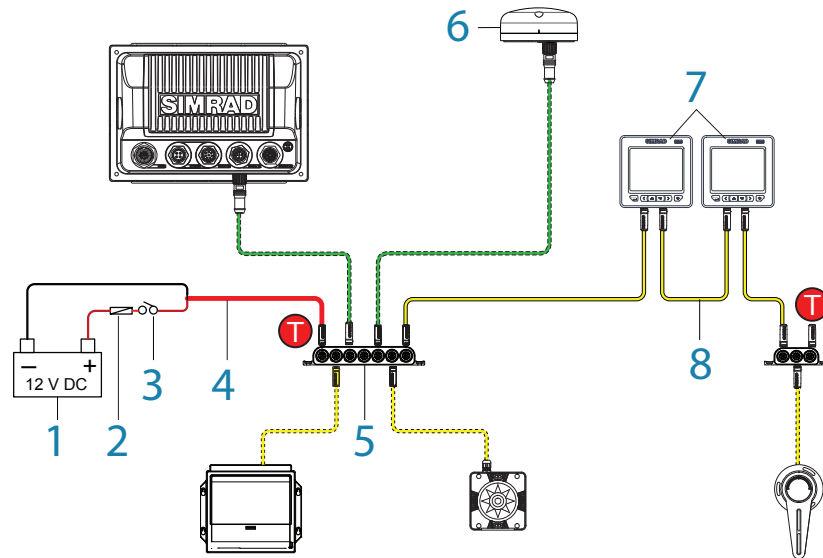

- 1 SimNet power source. Stable 12 V DC only**
- 2 5 Amp fuse or breaker**
- 3 Switch**
- 4 SimNet power cable with termination (red disc) (24005902)**
- 5 SimNet 7 way joiner**
- 6 SimNet or NMEA 2000 GPS antenna**
- 7 SimNet backbone daisy chained using instruments with two SimNet ports.**
- 8 SimNet backbone**

For larger systems introduce power at central point in the backbone to “balance” the voltage drop of the network. Use SimNet cable without termination (yellow cap) (24005910)

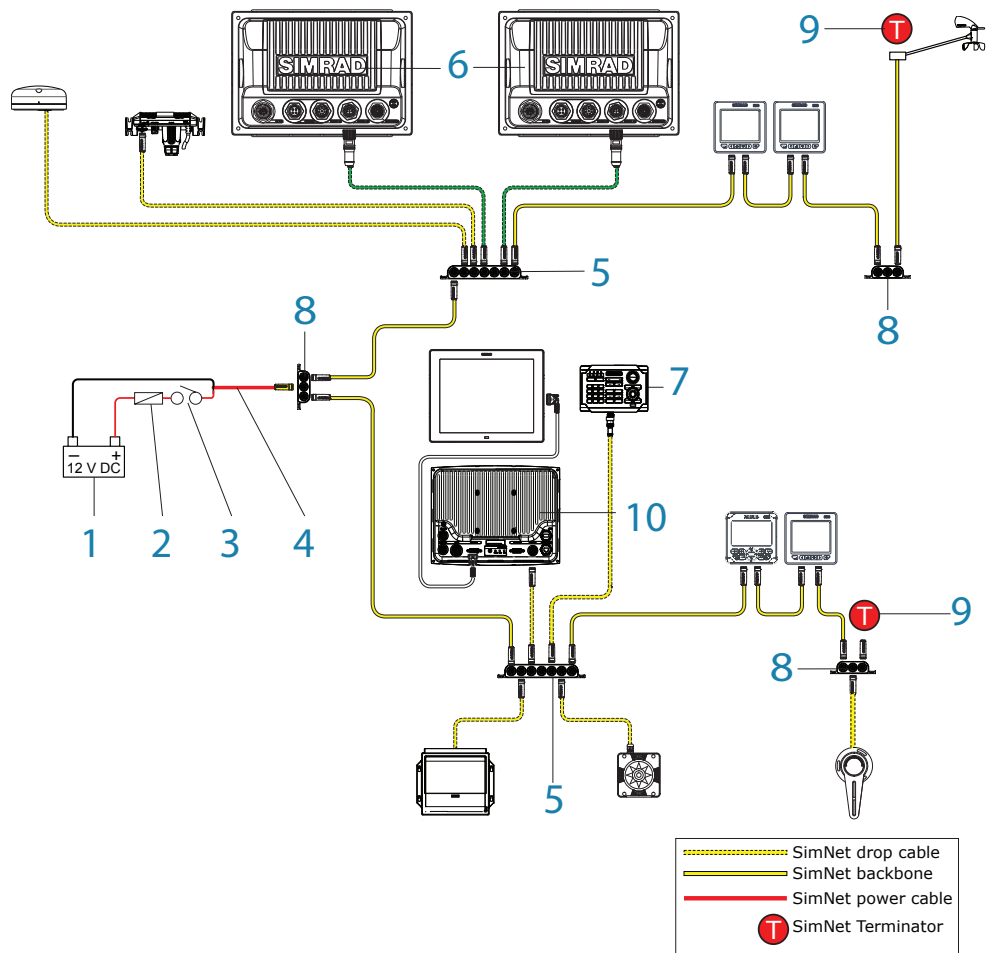

- 1 SimNet power source. Stable 12 V DC only
- 2 5 Amp fuse or breaker
- 3 Switch
- 4 SimNet power cable without termination (yellow disc) (24005910)
- 5 SimNet 7 way joiner
- 6 NSS Display
- 7 OP40 Controller with Micro-C to SimNet cable
- 8 SimNet 3 way joiner
- 9 Terminator (SimNet Wind Vane includes built-in terminator)
- 10 NSO Marine Processor

Integrating SimNet and other NMEA 2000 networks

Increasingly there are vessels that will have other NMEA 2000 based networks provided by different manufacturers. If networks from different manufacturers are required to share data, it is important to plan how both networks are going to interface to each other.

All NMEA 2000 compliant networks follow the same NMEA 2000 rules:

- a continuous backbone with devices connecting by a drop cable no more than 6 m (20 ft)
- two terminators, one at each end of the network
- a single 12 V DC power supply

Data bridging

NMEA 0183 to SimNet / NMEA2000:

All supported NMEA 0183 sentences entering the system are internally bridged (converted) to SimNet / NMEA 2000, and distributed on SimNet for any other devices to use. The only exception is AIS data.

SimNet / NMEA 2000 to NMEA 0183:

Only the selected SimNet / NMEA 2000 active data sources for the NSS are used in bridging. The NMEA 0183 sentences shown in the 'Transmit' rows of the NMEA0183 Supported Sentences table will be generated if the data is available on SimNet / NMEA2000.

Ethernet to SimNet:

Limited data is bridged from the Ethernet echosounder: Speed, depth and temperature are bridged to SimNet and NMEA0183.

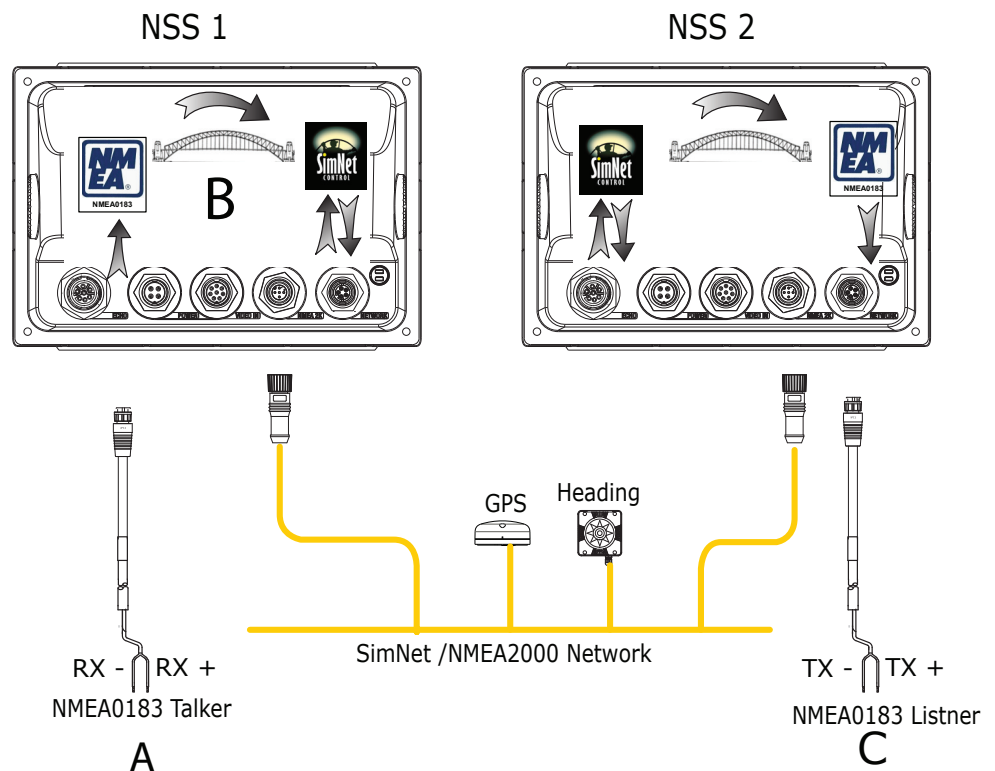

Example of data bridging

A	In this example a NMEA0183 (talker) is connected to NSS 1
B	The NMEA sentences are bridged across to SimNet and distributed on the SimNet network. Note: AIS data is not bridged
C	The NMEA0183 listener connected to NSS 2 can receive the NMEA0183 sentences from the device connected to NSS 1 and also from other devices that are on the SimNet network, in this case heading and GPS

- **Note:** An NMEA0183 talker can be connected to each NSS, and both sets of data will be converted to SimNet. Each display can be setup for outputting selected NMEA sentences.
- **Note:** Speed, temp and depth data from the echosounder transducer that is to be displayed as an instrument has to bridge from Ethernet to SimNet. An NSS display has to be nominated to bridge the data. If this nominated display is turned off, no data will be displayed, until the display is turned on or another display is selected to bridge the data (see page 38)
- **Note:** NMEA0183 to SimNet bridging only applies to the NMEA0183 sentences outlined in the Supported NMEA0183 sentences section of this manual (see page 64)

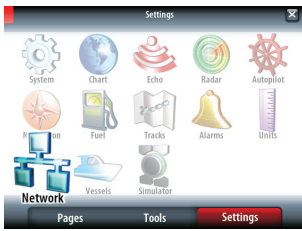

NMEA 2000 / SimNet setup

Data setup is required on initial start up of the system, or if any part of the SimNet or NMEA 2000 network has been changed or replaced.

From Network in the main system settings menu you can:

- select SimNet / NMEA2000 data sources either automatically or manually
- configure instance numbers for SimNet / NMEA2000 devices
- control how device parameters such as backlighting, units and damping are grouped on the network
- select to share waypoints via SimNet or NMEA2000
- monitor and diagnose both Ethernet and SimNet Networks
- setup NMEA0183 port, baud rate and output data
- control damping
- calibrate water speed derived from a SimNet / NMEA2000 source

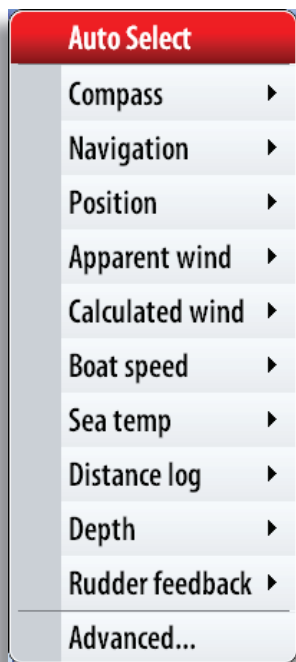

Auto Select (Source Selection)

The Auto Select option will look for all sources connected to the NSS system. If more than one source is available for each data type, the NSS will automatically select from an internal SimNet priority list.

Make sure all devices are connected and are turned on before selecting the Auto Select option.

Manual source selection

Manual selection is generally only required where there is more than one source for the same data.

Group source selection (SIMRAD)

SimNet products such as the NSS, IS20 or AP24 have the ability to;

- use data sources that all other products on the network use, or alternatively use a data source independently from other units.
- globally change all displays over to a different source from any display. (This will only include products set to Simrad Group mode.)

In order to enable group selection, the device must be set to Simrad.

There are up to 11 categories of sources such as Compass, Navigation, Position etc. Under each of these categories a display can be set to receive data from sources as part of the Simrad group or receive the source data independently from the group (None).

Group source selection (NONE)

In some cases it may be desired that an NSS on a network receives the same type of data, but from different sources to that of the rest of the network devices. To do this set the data Group setting to None, and select a source for the data.

Advanced source selection

This allows the most flexible and precise manual control over which devices provide data to the NSS.

Some data sources, such as those for fuel level, or engine RPM, can only be changed via the Advanced menu. Occasionally Auto Select may assign sources incorrectly, which may be corrected using the Advanced Source Selection. An example of this is where twin installations with NMEA2000 compliant engines are not programmed with unique instance numbers. This means that the auto select feature can't determine which engine is fitted on the port and which is fitted on the starboard side.

11

Ethernet (NETWORK port)

The NSS system uses an Ethernet network to interconnect high bandwidth devices such as radar, echosounder and to another NSS, NSE or NSO displays. The NSS7 and NSS8 displays have one NETWORK port each, whereas the NSS12 has three Ethernet ports. Navico Ethernet network cables have orange connectors that are retained by a bayonet type locking collar.

→ **note:** a maximum of two NSS may be connected to the same network.

Connecting directly to a single device

The Ethernet port is auto sensing, meaning that the NSS can connect to one Network module directly with out the use of a cross over cable or switch.

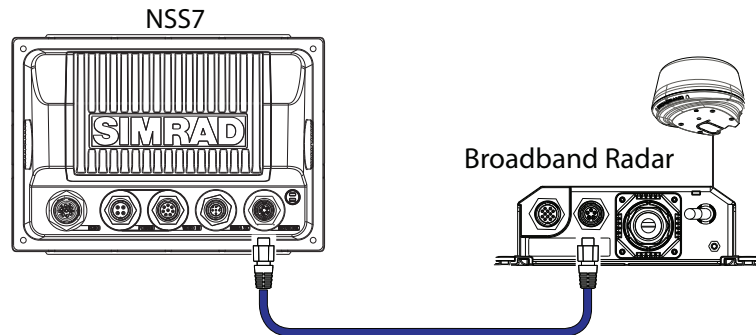

Connecting to multiple devices

Expanding the NSS7 and NSS8

For NSS7 and NSS8; If connecting more than one Ethernet device use the optional network expansion Port (NEP-2).

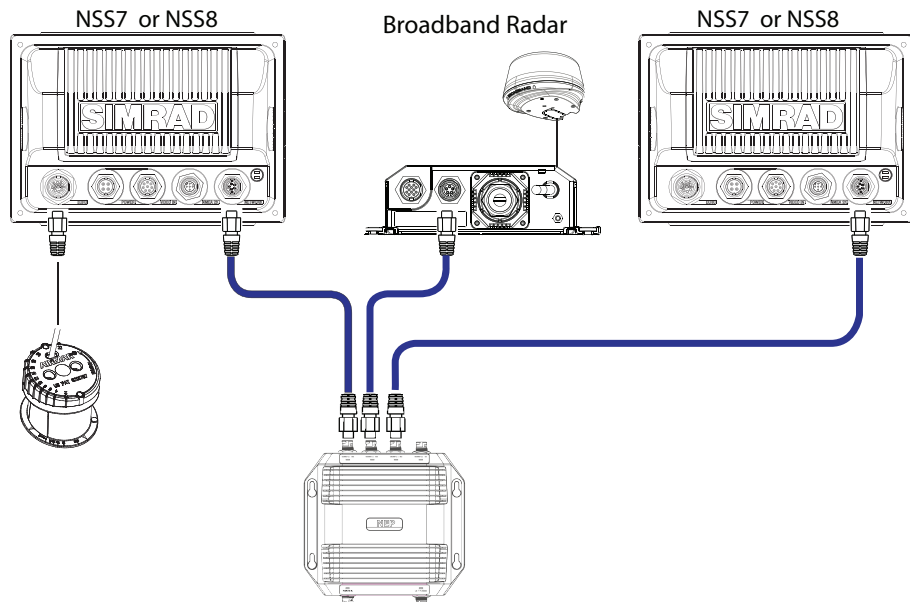

If the number of ethernet devices exceeds the number of available ports on the NEP-2, it is possible to link two or more NEP-2 modules together to provide the required ports. Every additional NEP-2 will provide an extra 4 ports, but will use up one port on the NEP-2 it is connected to.

Expanding the NSS12

With the NSS12, up to three ethernet devices can be connected directly to the unit. If more than three modules need connection, use the optional network expansion port (NEP-2).

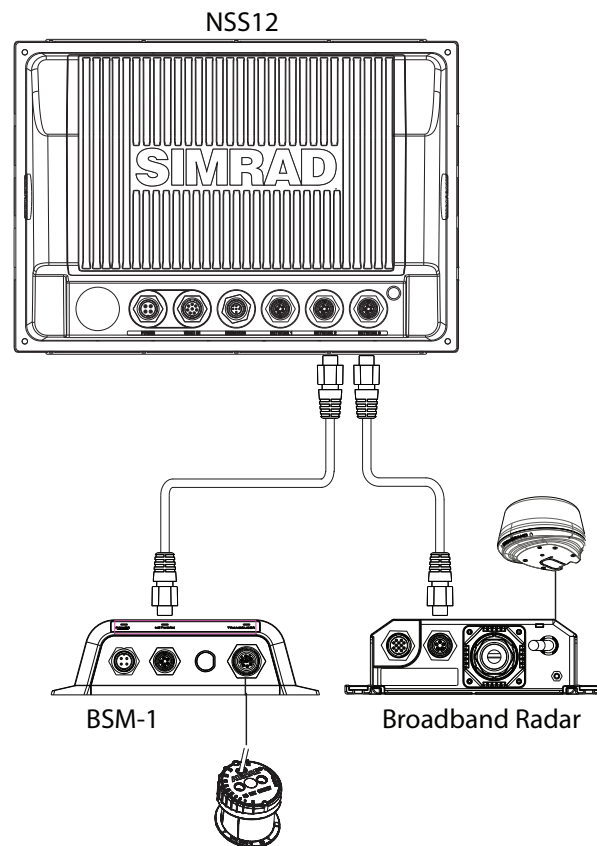

A second NSS connected to one of the NSS12's three built in ports will have full visibility and control over any devices connected to another port on the NSS12, in the same way it would if all devices were connected via an NEP-2 expansion port.

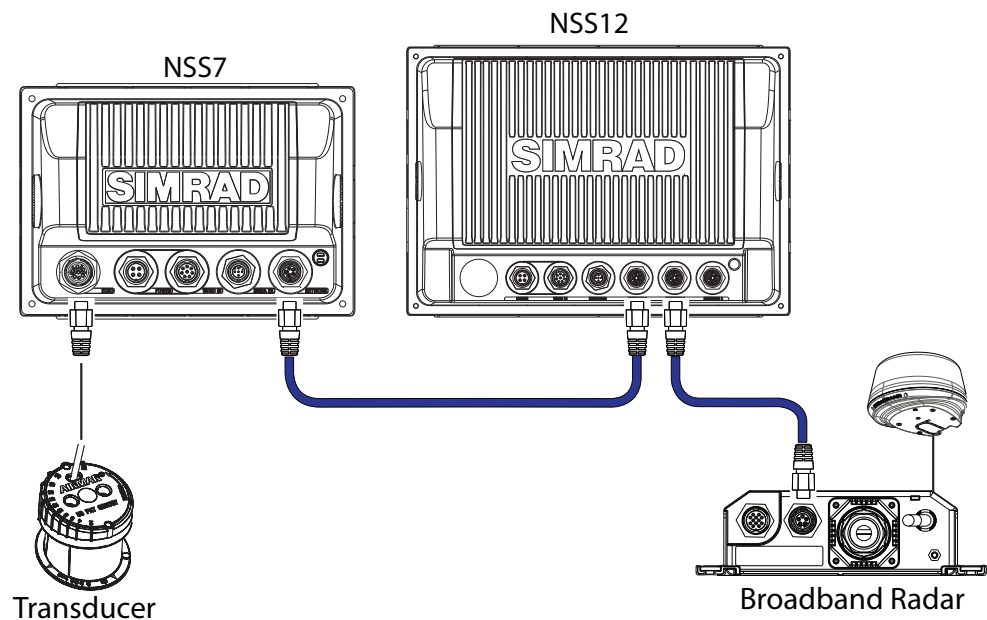

Ethernet setup

No special setup is required for establishing an ethernet network, it is all 'plug and play'. An NEP-2 connected between an NSS and another network module (e.g. BSM-1) will automatically start working, and relay data between the two devices.

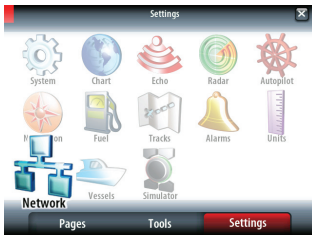

Diagnostics

The UDB (User Data Base) tab, on the diagnostics page, provides information on Ethernet activity.

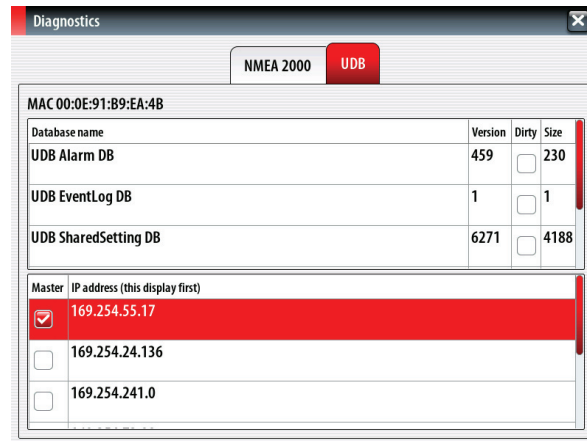

Databases

The window titled 'Database name', gives an account of the various synchronised databases that ensure Simrad display units (NSS, NSE, and NSO) are all using the same user settings and data. Databases can become unsynchronised when one or more displays in a multi display network are not powered up while other displays are being operated. Creation of waypoints, routes, tracks, and altering global settings all have an effect. When two unsynchronised displays are started up together again, some initial activity will be seen on this page.

IP addresses

The window titled 'Master IP address...' shows the IP address of the display being viewed, as well as the IP address of the Master display in a multi display network. Where the device being viewed is the master, only one IP address may be shown. Any devices previously assigned as master will also show in this list.

Module network light

The network LED on modules such as NEP-2, BSM-1, and RI10, can be useful for determining if the network is fundamentally operational. No light indicates no connection. A rapidly blinking green LED means the network module is communicating with another device.

12

Autopilot

The Simrad NSS includes complete autopilot integration. When NSS is connected to a compatible Simrad Autopilot Computer (AC12, AC42, and SG05), you will have complete control, setup and integration with your autopilot. The NSS display can be used in conjunction with Simrad AP24, or AP28 Control units or the NSS can be used alone to conserve dash space.

Wiring the autopilot system

Using the AC12 or AC42 autopilot computer

The AC12/AC42 is connected to the NSS system using the SimNet network.

For more information about how to install and wire the autopilot, refer to the separate AC12/AC42 Installation manual (part no 20222568).

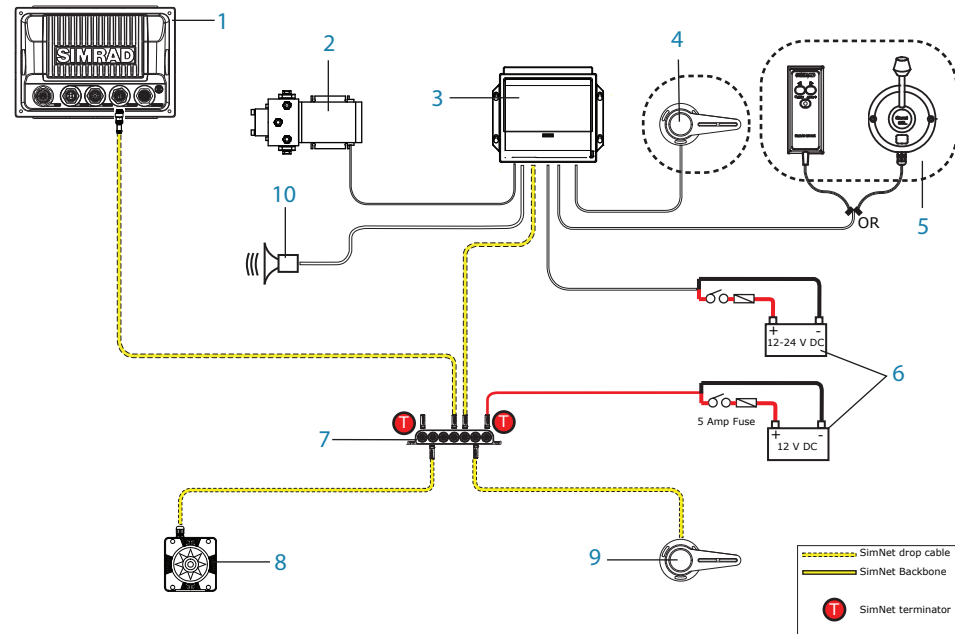

- 1 NSS Display
- 2 Pump / Drive (RPU160, RPU300, DD15, HDL2000x)
- 3 AC12 or AC42 Autopilot computer
- 4 RFU300 (Alternative option to RF25)
- 5 R3000X / S35 (optional steering controls)
- 6 DC Supply
- 7 SimNet 7 way Connector
- 8 RC42 Rate Compass
- 9 RF25 Rudder Feedback
- 10 Alarm Buzzer (optional)

Using the SG05 EVC gateway

The SG05 is connected to the SimNet network in place of Autopilot computer. It connects to a Volvo Gateway for communication with Volvo's EVC system.

Note that rudder angle data is sourced from the EVC system and a separate rudder angle indicator is not required.

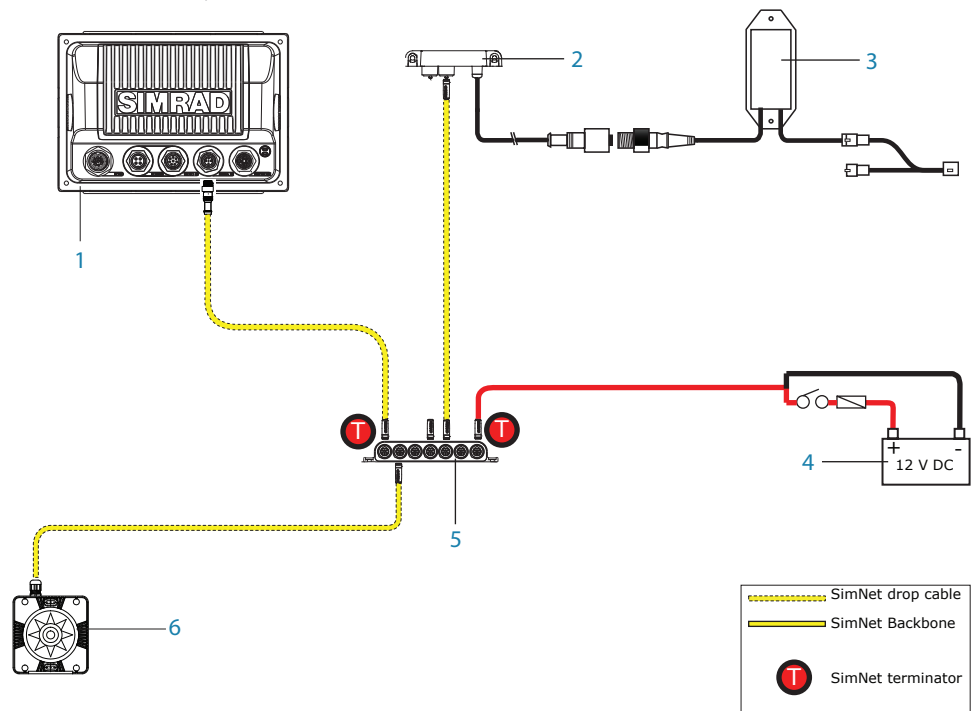

- 1 NSS Display
- 2 Simrad SGO5 SimNet - Volvo Gateway
- 3 Volvo Gateway (p/n: 000-1-258-001)
- 4 12V DC Supply
- 5 SimNet 7 way connector
- 6 RC42 Rate Compass

Autopilot setup

Verifying the autopilot connection

When an AC12, AC42, or SG05 is connected to the NSS system, the NSS will automatically detect the autopilot and an Autopilot menu item will be included in the **Settings** menu.

If no **Autopilot** item is available in the menu, establish the connection by running the auto select process.

The auto select process may also be used if the list of data sources needs to be updated when a unit has been physically replaced.

If the AC12, AC42 or SG05 is later disconnected, the **Autopilot** menu item will remain available, but only a few of the menu items will be available.



Commissioning the autopilot

When the autopilot installation is completed, the commissioning procedures must be performed. Failure in setting up the autopilot correctly may prohibit the autopilot from functioning properly.

The setup of the autopilot computers (AC12/42) can be done in full from either an NSS unit or from an AP24 or AP28 control head (if fitted). The following sections describe how you configure the autopilot from the NSS unit. If you select to setup the system from an AP24 or AP28

control head, refer to the AP24 Operator manual (part no 20222535) or the AP28 Operator manual (part no 20222527).

If you connect the NSS to an already commissioned autopilot system, you only have to do an automatic source selection as described above before the autopilot is ready to be used.

Dockside setup

Initiating the required dockside setup is done from within the Commissioning dialog. Completed procedures are labelled with a tick.

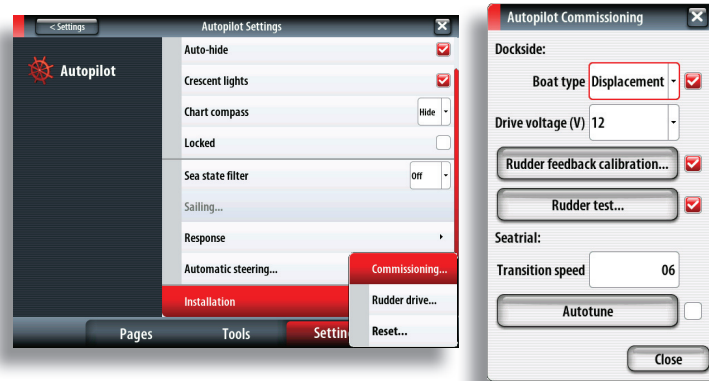

When the autopilot computer is delivered from factory AND ANY TIME AFTER AN AUTOPILOT RESET HAS BEEN PERFORMED, you will have to run a complete setup again.

All steps in all commissioning procedures are clearly described on-screen, and you will be guided step by step through the process.

1. Press the **STBY/AUTO** key to ensure that the autopilot is in standby mode
 2. Activate the autopilot commissioning dialog as shown above
 3. Select boat type
 - The boat type setting is used by the system to select appropriate preset steering parameters. It will also affect available autopilot features.
 4. Perform the rudder calibration
 - Used if you have a rudder feedback unit installed. This calibration is used to ensure that the physical rudder movement corresponds to the rudder angle displayed on the NSO unit.
- VRF (Virtual Rudder Feedback) calibration:**
- The Virtual Feedback option enables your autopilot to steer without a conventional rudder feedback unit. This function is designed for vessels up to 40 ft. powered by outboard or stern drives only.
 - The Virtual Feedback option will only be available when there is no feedback unit connected at first time turn on or at turn on after an autopilot reset.
- **Note:** Installing a feedback unit will enhance the performance of the autopilot and provide an accurate rudder angle indicator on the autopilot display. Unless impractical or impossible, a rudder feedback unit should be installed.
5. Set the drive voltage
 - Refer to the drive unit table in the AC12/AC42 Installation manual or to your drive unit documentation for information.
 6. Run the rudder test as described in the on-screen instructions
- **Note:** If the boat uses power assisted steering, it is important that the engine or electric motor used to enable the power assist steering is turned on prior to this test.

Stand CLEAR of the wheel and do not attempt to take manual control of the wheel during this test!

- When this test is started the autopilot computer will issue a series of PORT and STBD rudder commands and automatically verify correct rudder direction. It detects minimum power to drive the rudder and reduces the rudder speed if it exceeds the maximum preferred speed (8°/sec.) for autopilot operation. The system will also detect whether the drive unit is a reversible motor or if a solenoid valve is operated.



Rudder drive setup

The rudder drive setup controls how the autopilot computer controls the steering system.

Drive voltage

Voltage specified for your drive unit.

The Drive unit voltage setting does not apply when the system operates solenoids on a continuous running pump/steering gear. Hence, the output voltage to the solenoids will be the same as the input voltage.

Refer to the drive unit table in the AC12/AC42 Installation manual or to your drive unit documentation for information

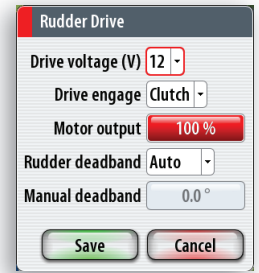

Warning: Selection of improper voltage level for your drive unit may damage both the drive unit and the AC12/42 even if the protection circuits are activated.

Drive engage

Clutch	This is the default setting and it allows you to steer the boat with the helm or wheel when in STBY mode (FU and NFU modes) as well as in all auto steering modes
Auto	This option is typically used to switch between two rudder speeds on a continuous running pump, used when different rudder speeds are required for automatic and Follow-up/Non-Follow-up steering

Motor output

Shows the amount of power needed to achieve the correct rudder speed. The reading is obtained from the Rudder test.

The automatically set value may be increased or decreased.

Rudder deadband

This parameter is used to prevent the rudder from hunting. The reading is obtained from the Rudder test which optimizes the deadband to the speed of the boat and the pressure on the rudder.

If the auto-setting does not perform properly due to high inertia from the wheel or a loose steering gear, it can be adjusted manually. Find the lowest possible value that will prevent the rudder from continuous hunting. A wide deadband will cause inaccurate steering.

→ **Note:** The rudder deadband setting is not available when the autopilot is configured for Virtual Rudder Feedback.

Seatrials

A seatrial can only be performed if the dockside settings are completed and confirmed.

The seatrial must always be performed in open waters at a safe distance from other traffic.

→ **Note:** You can switch the autopilot to standby mode and take manual control of the boat at any time during the seatrial by pressing the **STBY/AUTO** key.

The following seatrial calibration should be done:

- Compass calibration; used to automatically compensate for on-board magnetic interference
- Compass offset adjustment, used to compensate for a fixed offset in the final heading readout
- Wind calibration to compensate for a fixed mechanical offset of the Wind vane
- Boat speed calibration
- Transition HI/LO speed setting (the speed at which you want to change the set of steering parameters)
- Automatic tuning of the steering parameters
- Setting the seastate filer
- Saiboat setup

Compass calibration

Before the compass calibration is started, make sure that there is enough open water around the vessel to make a full turn.

The calibration should be done in calm sea conditions and with minimal wind to obtain good results. Follow the on-screen instruction, and use about 60-90 seconds to make a full circle.

During the calibration, the compass will measure the magnitude and direction of the local magnetic field.



- If the local magnetic field is stronger than the earth's magnetic field (the local field is reading more than 100%), the compass calibration will fail
 - If the local field is reading more than 30%, you should look for any interfering magnetic objects and remove them, or you should move the compass to a different location. The (local) field angle will guide you to the local interfering magnetic object.
- **Calibration** must be made on the compass that is active for the autopilot. If another model compass from Simrad or another manufacturer is installed, refer to the instruction for that compass regarding calibration.
- **Note:** In certain areas and at high latitudes the local magnetic interference becomes more significant and heading errors exceeding $\pm 3^\circ$ may have to be accepted.

Compass mounting offset

After compass calibration, the difference between the compass lubber line and the boat's center line should be compensated for.

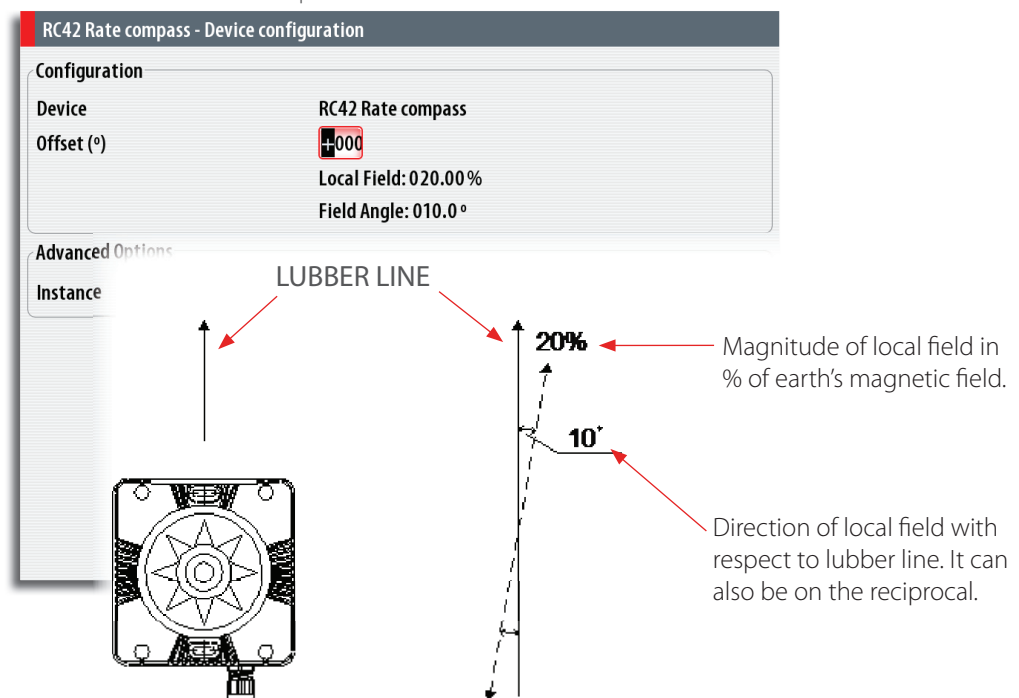

1. Find the bearing from the boat position to a visible object. Use a chart or a chart plotter
 2. Steer the boat so that the center line of the boat is aligned with the bearing line pointing towards the object
 3. Change the offset parameter so that the bearing to the object and the compass readout becomes equal. Refer graphic above
- **Note:** Make sure that both the compass heading and the bearing to the object have the same unit (°M or °T).

Setting the Transition speed (HI/LO)

This is the speed at which the system automatically changes from LO to HI steering parameters.

On power boats it is recommended that you set a value that represents the speed where the hull begins to plane or the speed where you change from slow to cruising speed.

On sailboats the transition speed should be set to 3-4 knots to give the best response in a tack.

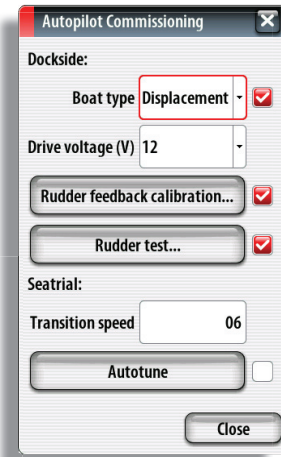
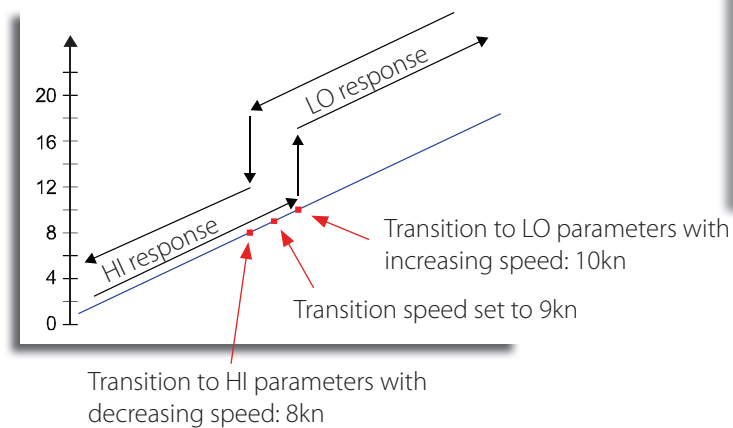

Active response parameter set is shown in the autopilot popup, and the following abbreviations are used:

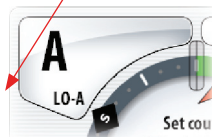

- HI-A High response parameters set automatically
- LO-A Low response parameters set automatically
- HI-M High response parameters set manually
- LO-M Low response parameter set manually

Autotuning

The autotune feature will run the boat through several tests and then automatically set the most important steering parameters.

Autotune is not required for the autopilot to function as it is preset with steering parameters that should steer most boats in the 30-50 foot range.

You can manually set all parameters that are set during autotuning. Refer next page.

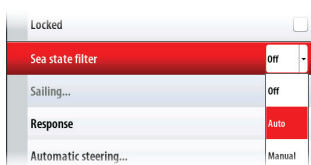

Seastate filter

The Seastate filter is used to reduce rudder activity and autopilot sensitivity in rough weather.

OFF	Seastate filter is disabled. This is default
AUTO	Reduces rudder activity and autopilot sensitivity in rough weather by an adaptive process. The AUTO setting is recommended if you want to use the seastate filter
MANUAL	Linked to the steering response control settings described previously. It may be used to manually find the optimum combination of course keeping and low rudder activity in rough but steady sea conditions

Setting sailing parameters

→ **Note:** Sailing parameter settings are only available if the boat type is set to Sail.

Tack time

When performing a tack in WIND mode, the rate of turn (tack time) can be adjusted. This will give single-handed sailors time to handle the boat and the sails during a tack.

A turn performed without shifting wind side, will also be made at a controlled turn rate.



Range	Change per step	Default	Units
2 - 50	1	12	seconds

Tack angle

This value is used to preset the course change used when tacking in AUTO mode. By pressing the left/right arrow keys the course will change as much as this value.

Range	Change per step	Default	Units
50 - 150	1	100	°

Wind function

With wind function set to Auto, the autopilot will automatically select between apparent and true wind steering. Auto is default and recommended for cruising.

When the boat is running, it will also be surfing on the waves. This may lead to significant changes in boat speed, and thereby also changes in apparent wind angle. True wind steering is therefore used when running, while steering to apparent wind is used when beating or reaching.

Apparent wind steering is preferred when you want to achieve maximum boat speed. The autopilot tries to maintain a constant apparent wind angle to get maximum thrust from a given trim of the sails.

When sailing in closed waters, the apparent wind angle may change temporarily due to wind gusts. It may then be preferred to sail to the true wind.

VMG optimizing

You can optimize the VMG to wind. When selected the function will be active for 5–10 minutes after a new wind angle has been set and only when beating.

Layline steering

Layline steering is useful when navigating. Cross Track Error (XTE) from the navigator will keep the boat on the track line. If the XTE from the navigator exceeds 0.15 nm, the autopilot will calculate the layline and track towards the waypoint.

Manually adjusting steering parameters

The autotune function in the autopilot is so refined that the majority of boats will need no further adjustments of the steering parameters. On some boats however, or in particular sea conditions, fine tuning of the steering parameters may improve the performance of the autopilot.

Transition speed

Refer previous description.

Rudder

This parameter determines the ratio between commanded rudder and the heading error. The higher rudder value the more rudder is applied.

If the value is too small it will take a long time to compensate for a heading error, and the autopilot will fail to keep a steady course.

If the value is set too high the overshoot will increase and the steering will be unstable.

Counter rudder

Counter rudder is the amount of rudder used to try to prevent the boat from yawing around the set course. Higher counter rudder settings result in more rudder being applied.

The best way of checking the value of the Counter rudder setting is when making turns.

The figures illustrate the effects of various Counter Rudder settings;

A: Counter rudder too low; overshoot response

B: Counter rudder too high; sluggish and creeping response

C: Correct setting or counter rudder; ideal response

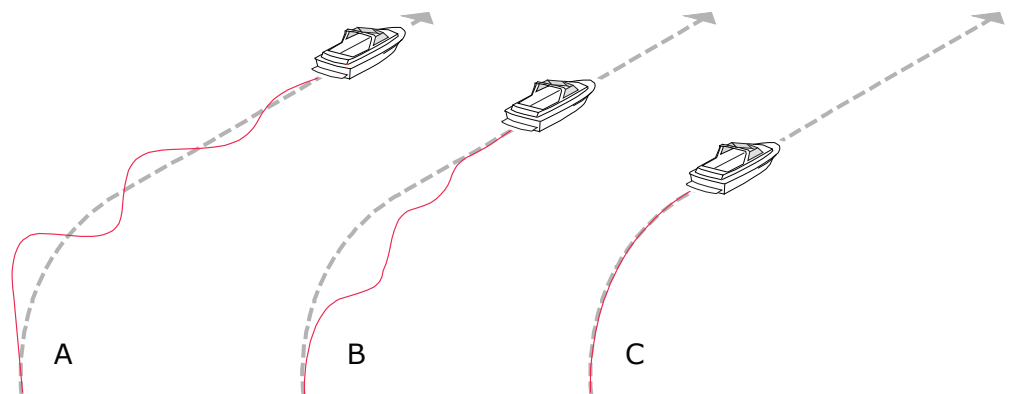

Auto trim

This parameter defines how fast the autopilot shall correspond after having registered a heading error.

The standard value is 40 seconds which should work well on most boats. Rule of thumb: Set to same value (seconds) as the boat's length in feet. On boats operating on VRF the value should be set to 20 seconds.

Rate limit

Sets the maximum allowed rate of turn.

The value should be kept at 6.0°/second unless there is a need for more rapid response in turns.

Minimum rudder

This parameter filters small rudder commands to prevent high rudder activity.

Some boats may have a tendency to not respond to small rudder commands around the "course keeping" position because of a small rudder, a rudder deadband, whirls/ disturbance of the water-stream passing the rudder or it is a single nozzle water jet boat.

By increasing the Minimum rudder parameter you may improve the course keeping performance on some boats. This will however increase the rudder activity.

Minimum wind angle to port and starboard

These parameters should be set identical to the minimum apparent wind angle that will keep the sails well shaped and give an acceptable thrust. The parameters will vary from boat to boat.

The settings are used for the tack-prevent function. They also applies when the autopilot is operating in WindNAV mode. Refer to the **Operating the autopilot** section.

You can select different minimum wind angles for port and starboard. The difference between port and starboard will be taken into account when calculating the Distance To Turn (DTT).

Navigation change limit

This parameter defines the maximum course change where the autopilot is allowed to automatically change the course when the NSS follows a route (NAV steering).

If the required course change to next waypoint in a route is more than the set limit, you are prompted to verify that the upcoming course change is acceptable.

13

CZone connection to SimNet

When interfacing to C-ZONE network it is recommended to use a BEP Network interface bridge (A) to join the two network backbones together.

The CZONE / NMEA2000 Network interface bridge isolates the power of the two networks, but allows data to be freely shared between both sides.

The Network Interface has built in terminators so needs to be placed at the extremity of each network backbone.

The Interface Bridge can also be used for expansion of the SimNet network, when the maximum node limit (node = any device connected to the SimNet network) for the network has been reached or the maximum cable length of 150m will be exceeded. Once an Interface Bridge has been fitted, a further 40 nodes and additional cable length can be added.

The Network Interface is available from your BEP dealer. For more information please refer to the BEP web site www.bepmarine.com.

BEP part number 80-911-0057-00

A SimNet to Micro-C cable (24006413) is required to connect to a SimNet network.

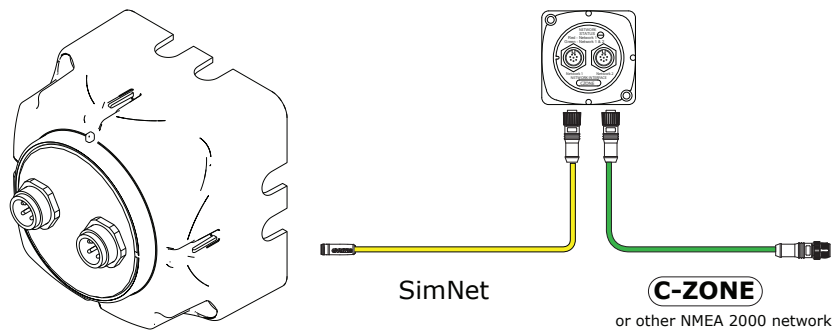

Below is the correct method to interface to a C-ZONE network. In this example, power is injected twice but connecting the two networks together via the BEP Network interface bridge provides power isolation and correct termination.

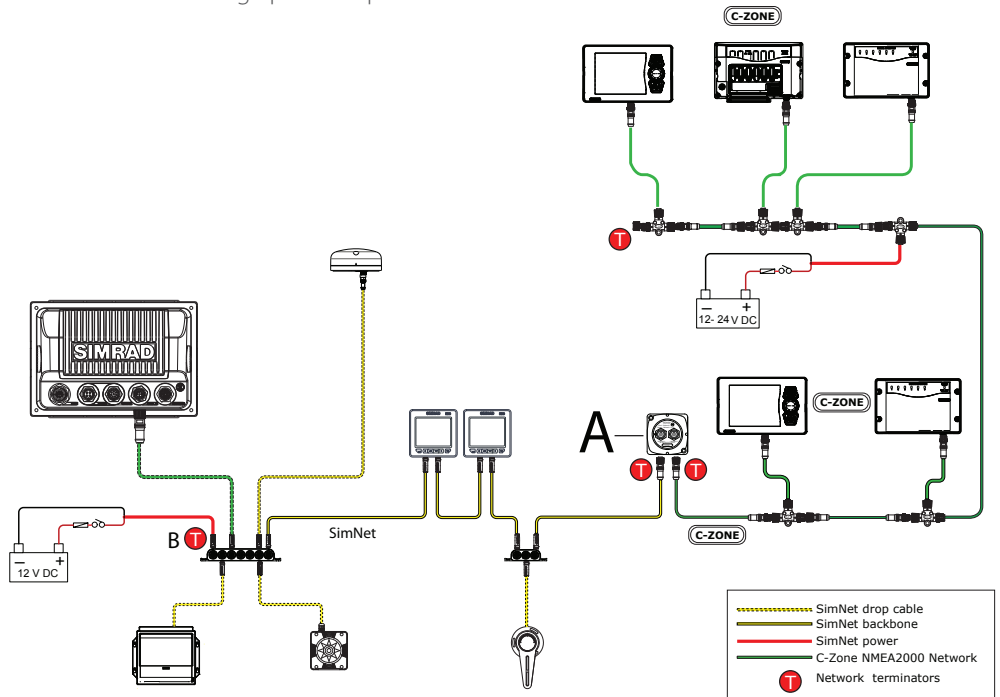

CZone setup

In order to communicate with the CZone modules connected to the network, the NSS display must be assigned a unique CZone Display Dipswitch setting.

The functionality of the CZone system is determined by the CZone Config File (.zcf), which is stored on all CZone modules, and supported Simrad displays such as the NSS. The file is created using the CZone Configuration Tool, a specialised PC application available from BEP Marine Ltd, and associated CZone distributors.

The NSS system provides a means to load the Config file, as well as apply updates to module firmware, removing the need to take a laptop computer aboard the vessel.



Enabling CZone functionality

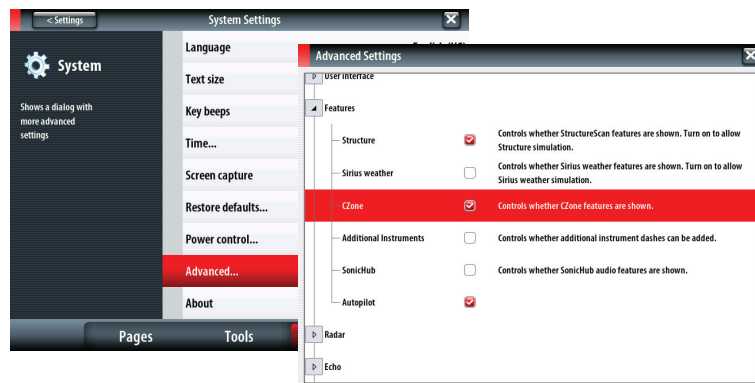

Once CZone is enabled, an additional CZone menu appears at the bottom of the Advanced Settings page.

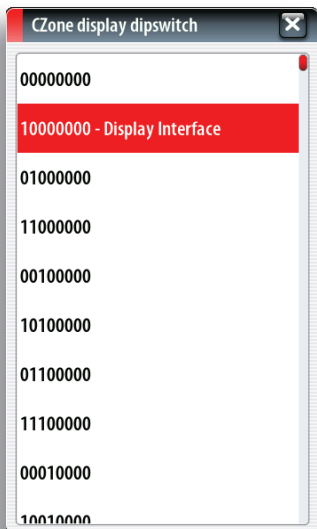

Assigning the dipswitch setting

Every Simrad product capable of controlling and viewing CZone devices must be assigned a virtual dipswitch setting. This setting is unique for each device. Typically it is set after the config file already exists on the CZone system, but it may also be set in advance.

When the config is already available on the network, it will immediately commence uploading to the NSS once the dipswitch is set. Allow this to complete, without interruption.

Setting CZone to display at startup

With this option selected, the CZone control page will be shown first, every time the NSS is powered up.

CZone backlight control

Enabling this will cause the NSS to synchronize its backlight setting with that of any CZone Display Interfaces set up to share backlight settings.

Import and backup a config file

The files page may be used to import CZone config files, or export a copy to a Micro SD card. Importing will overwrite the existing file on the NSS and all connected CZone devices.

For further information refer to "Applying Software Updates" on page 53

Upgrading module firmware

The files page also allows the loading of CZone module firmware updates. For further information refer to "Applying Software Updates" on page 53

14

Applying Software Updates

From time to time Simrad releases software updates to its existing products. Updates are created for a variety of reasons; to add or improve features, to add support for new external devices, or to fix software bugs.

Updates can be found on the Simrad website: <http://www.simrad-yachting.com/Downloads/Software-Updates/>

The NSS may be used to apply software updates to itself, and to external SimNet and CZone devices, with files read off a Micro SD card.

Before initiating an update to the NSS itself, be sure to back up any potentially valuable user data.



Backing up user data

There are two files that can be backed up that relate to user changes:

- Waypoints Routes and Tracks
- Settings (includes preferences such as unit settings, and custom new pages)

The backup procedure is similar for both.

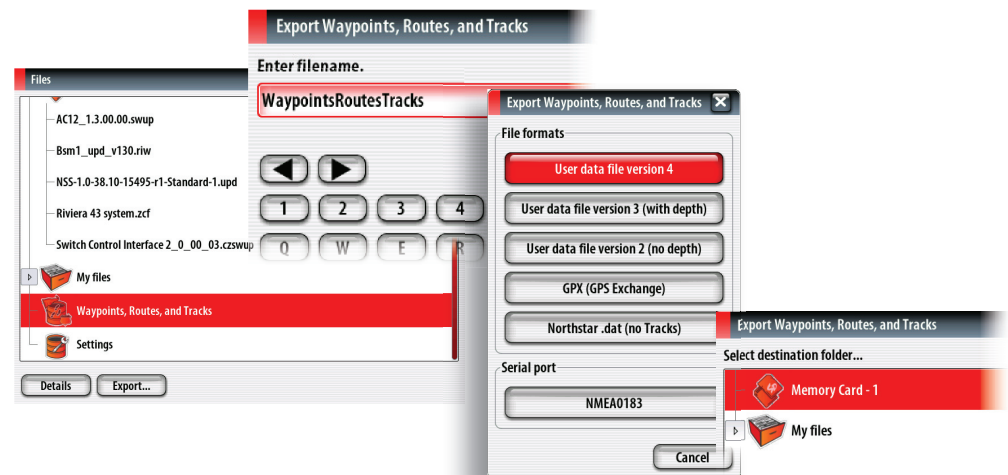

The file formats for waypoint backup:

- User data file version 4: Use with current Navico MFDs (NSE, NSO, HDS). Offers most detail
- User data file version 3 (with depth): Use with legacy Lowrance GPS chartplotters
- User data file version 2 (no depth): Use with legacy Lowrance GPS chartplotters
- GPX (GPS Exchange): Use with some other manufacturers' GPS products, and PC applications
- Northstar .dat (no Tracks): Use with legacy Northstar chartplotters

The Serial port option outputs the waypoints over NMEA 0183. The receiving GPS/PC will typically need to be set to allow import of waypoints.

If the NSS is defaulted, or user data is accidentally deleted, simply return to the files page, highlight the backup file, and select **Import**. View file details for creation date.

NSS software updates

The update file must be loaded to the root directory of the SD card.

In the files menu, locate the update file on the SD card and select **Upgrade**. Accept the prompt to reboot the unit, and wait a few moments as the unit restarts. After a few seconds the unit will display something similar to the following image:

Select update to run

* 0: Cancel

1: "NSS-xxxx.upd"

Turn the rotary knob so that the asterix appears next to the update file. Press the rotary knob to commence update. Do not remove the Micro SD card or repower the NSS until the process is completed (this will typically take no more than a couple of minutes).

SimNet and Ethernet device updates

To update SimNet and ethernet devices select the **Upgrade** option presented when the file is highlighted, followed by confirmation of the device you wish to upgrade. Do not interrupt the upgrade process.

15

Dimensioned Drawings

NSS7

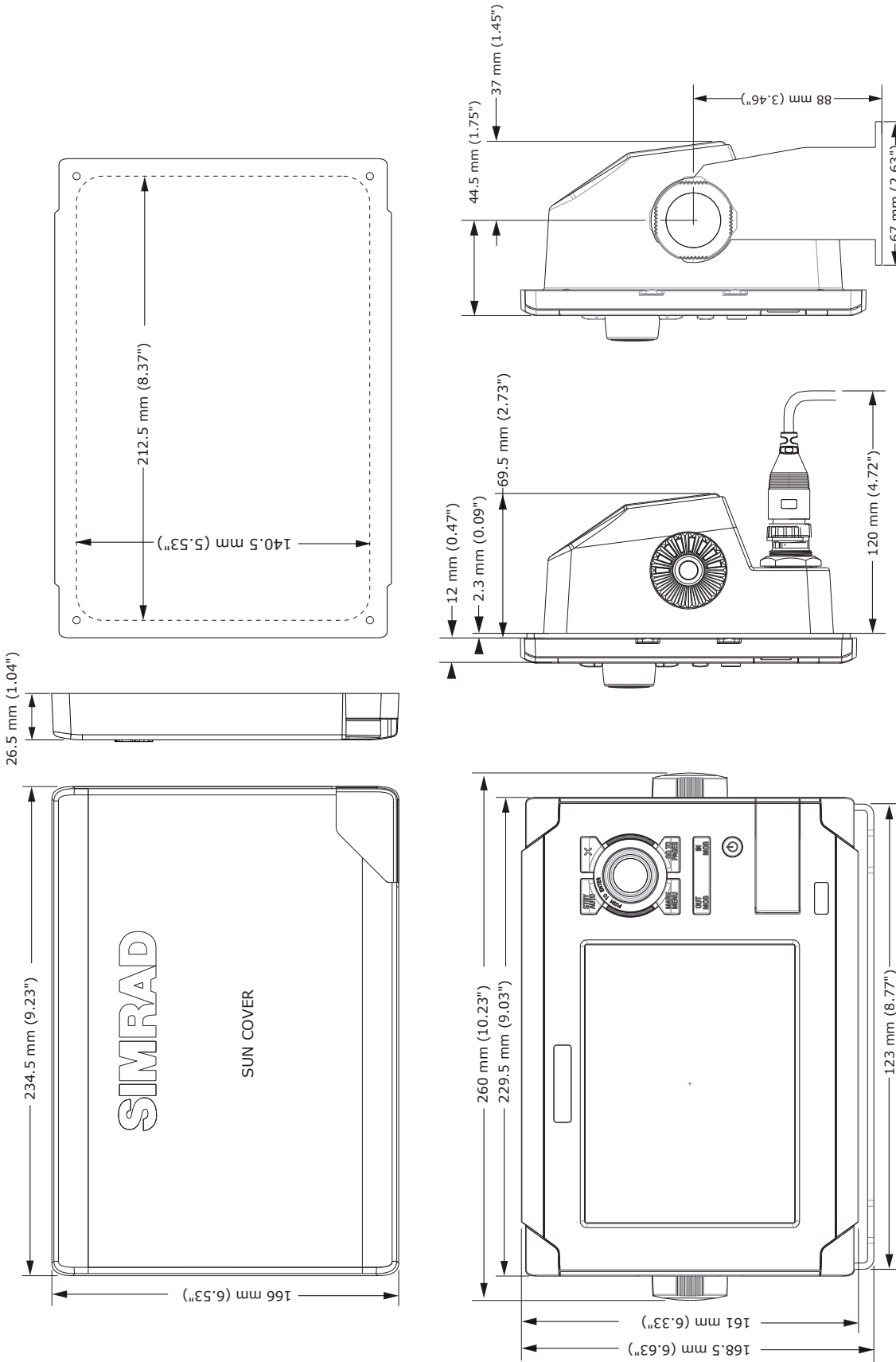

NSS8

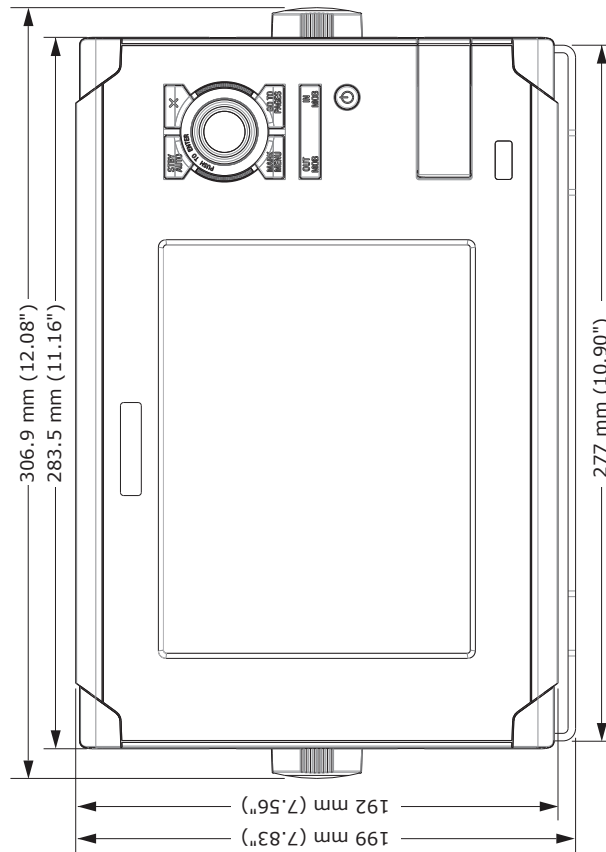
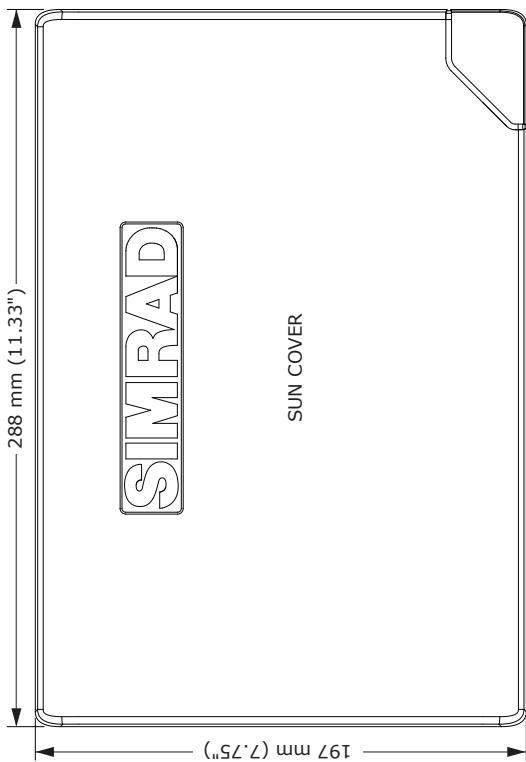
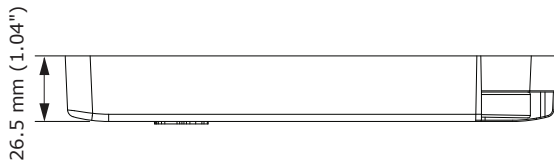
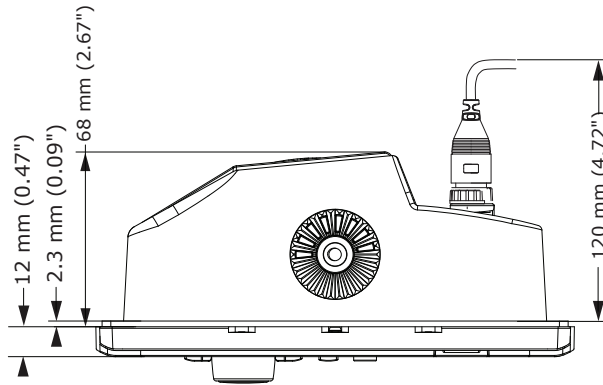
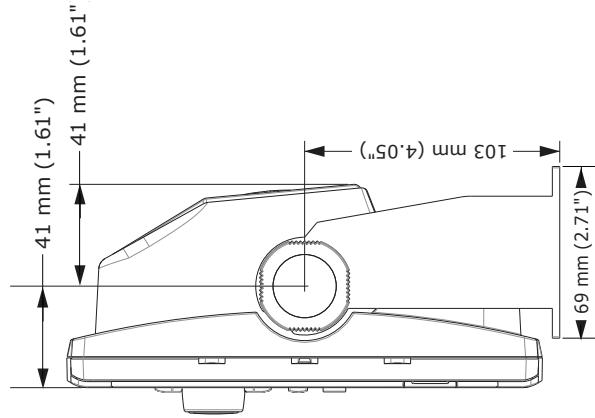
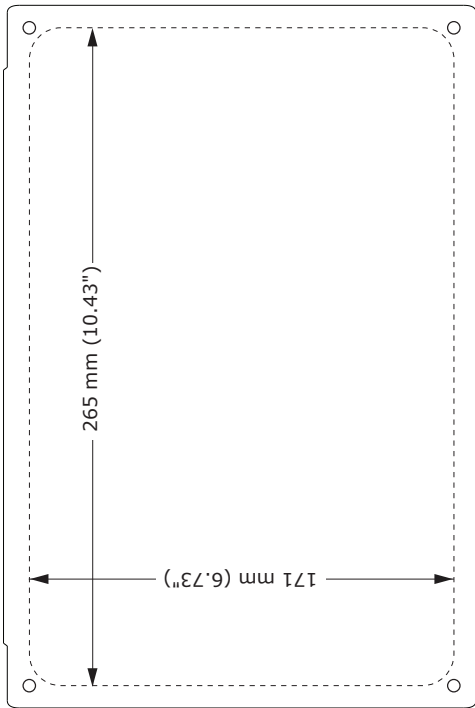

NSS12

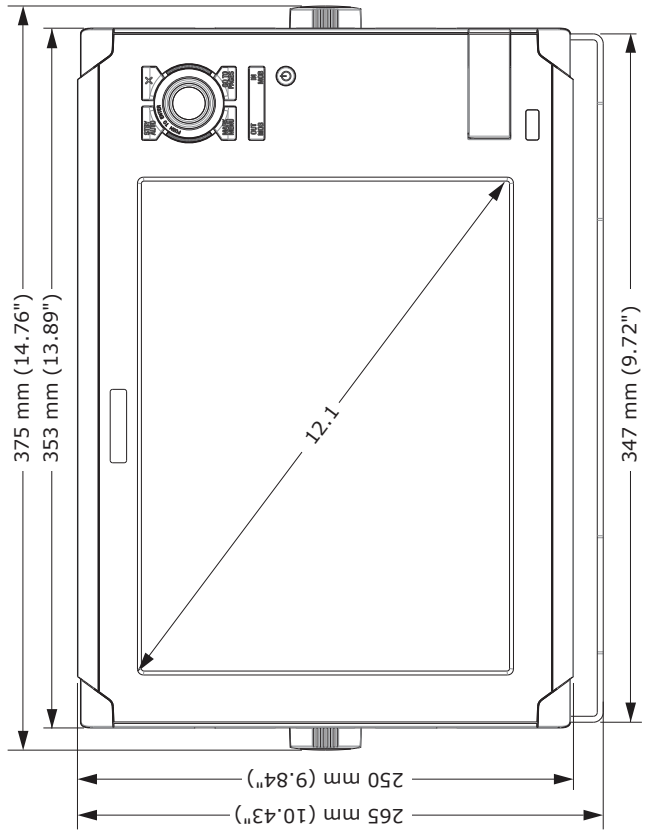
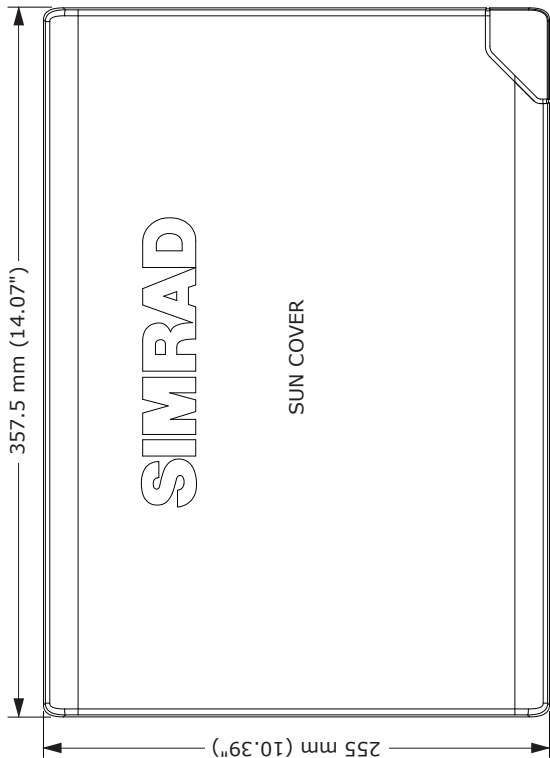
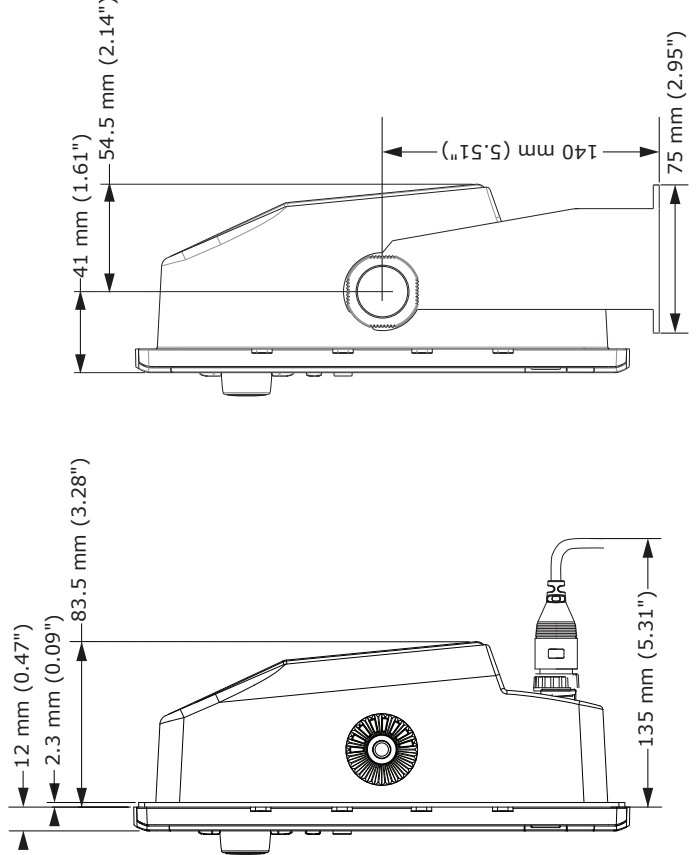
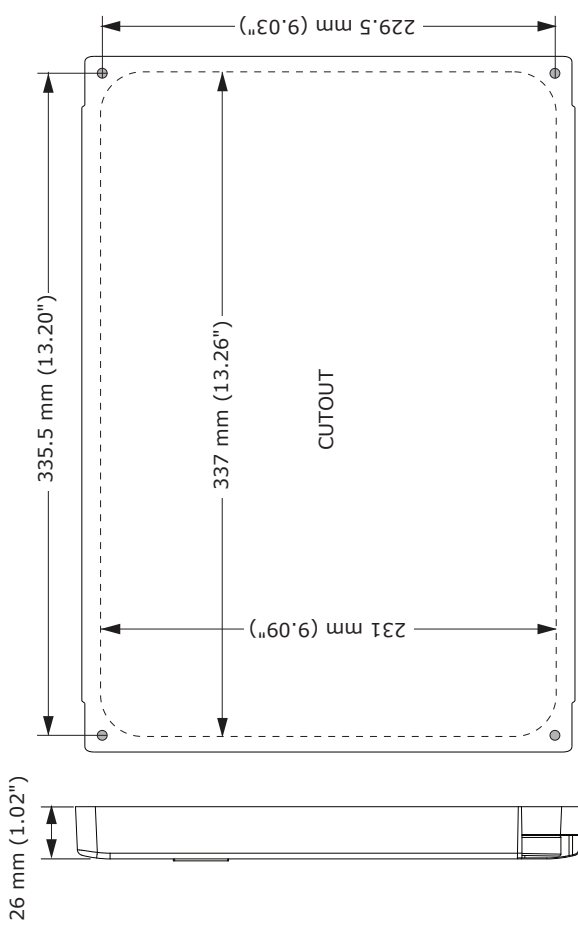

16

Connector Pinouts

Power

Power Connector

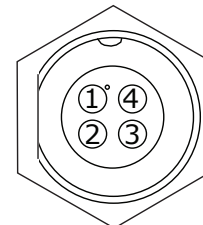
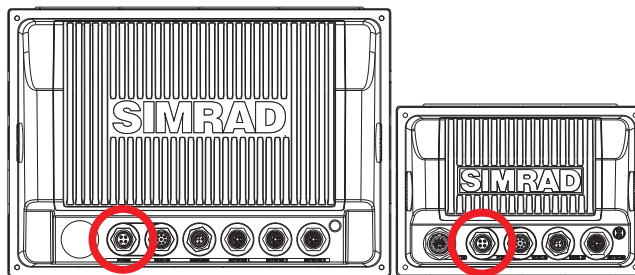

Power Cable: 000-00129-001 (included)

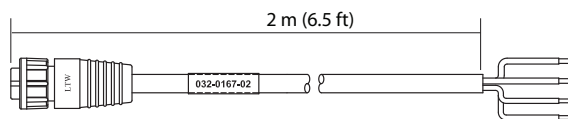

Pin	Wire Color	Function
1	Black	Battery
2	Blue	External Alarm
3	Yellow	Power Control
4	Red	Battery (+) 12 - 24V DC

Video / Data

Video / Data Connector

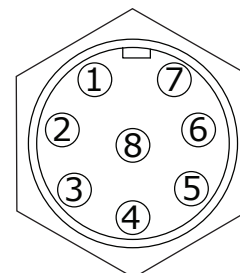
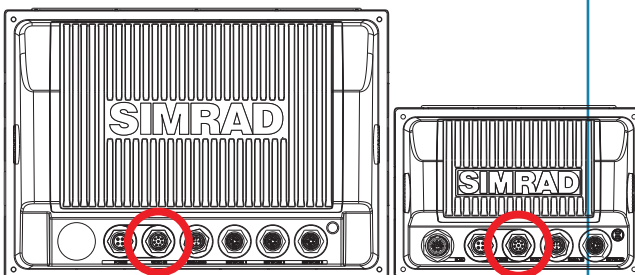

Video Cable: 000-00129-001 (included)

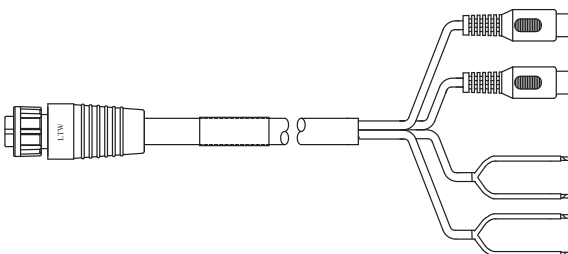

Pin	Wire Colour	Function
1	Red	Video 1 Ground
2	(coax)	Video 1 (+)
3	Green	Video 2 Ground
4	(coax)	Video 2 (+)
5	Blue	RS422 TX -
6	Yellow	RS422 TX +
7	Orange	RS422 RX -
8	Green	RS422 RX +

NMEA2000

SimNet / NMEA2000 Connector

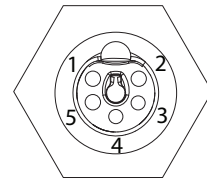
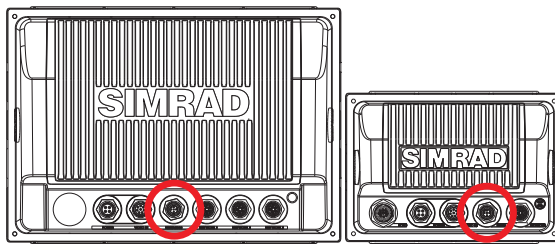

Pin	Function
1	CAN_H
2	SimNet power (+) 12V DC
3	SimNet power (-)
4	Shield
5	CAN_L

Network (Ethernet)

NETWORK (Ethernet) Connector

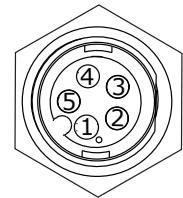
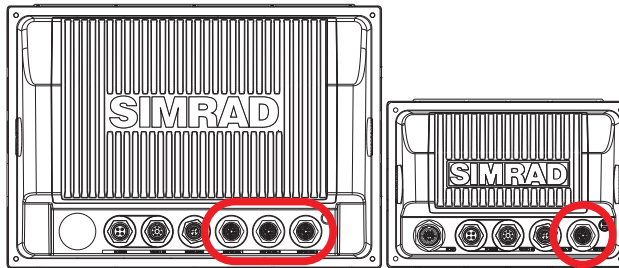

Pin	Function
1	TX +
2	TX -
3	RX +
4	RX -
5	Gnd

Echosounder

Echosounder Connector

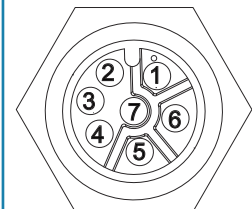
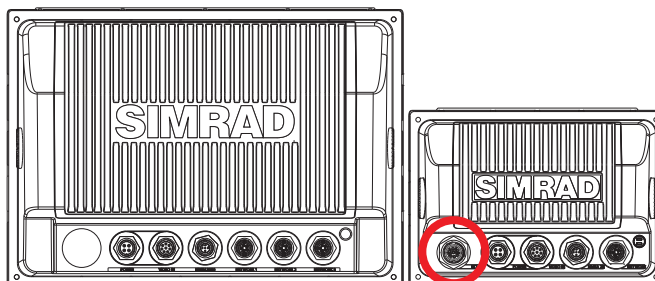

Pin	Function
1	Depth +
2	Speed
3	Speed power
4	Temp
5	Depth -
6	Shield
7	Temp / speed Gnd

17

Accessory cables

Simnet cables

Part Number	Description
SIMKIT-1	SimNet Starter Kit: <ul style="list-style-type: none">• 24005845 SimNet 5 m (16.5 ft) cable• 24006298 SimNet 7-Prong Multi-Joiner• 24005894 SimNet Termination Plug• 24005902 SimNet 2 m (6 ft) power cable w/terminator
SIMKIT-2	SimNet Starter Kit with one AT10 NMEA0183 interface <ul style="list-style-type: none">• 24005936 AT10 two way general NMEA0183 to SimNet Converter• 24005837 SimNet 2 m (6 ft) cable• 24005845 SimNet 5 m (16.5 ft) cable• 24006298 SimNet 7 Prong Multi-joiner• 24005894 SimNet termination plug• 24005902 SimNet 2 m (6 ft) power cable w/terminator
24005829	0.3 m (1 ft) SimNet cable
24005837	2 m (6.6 ft) SimNet cable
24005845	5 m (16.6 ft) SimNet cable
24005852	10 m (33 ft) SimNet cable
44172260	SimNet In-line joiner
24005860	SimNet T-joiner (3 prong)
24006298	SimNet Multijoiner (7 prong)
24006306	SimNet Bulkhead T-connector
24005878	SimNet cable gland
24005886	SimNet protection plug
24005894	SimNet termination plug
44172278	SimNet termination In-Line joiner
24005902	2 m (6.6 ft) SimNet power w/termination
24005910	2 m (6.6 ft) SimNet power w/o termination
24005936	AT10 Universal NMEA0183 converter
24005944	AT15 Active T-connector, IS15
24005928	SimNet cable protection cap
24005729	SimNet to Micro-C (male) cable that connects a SimNet product to a NMEA2000 network
24006199	SimNet to Micro-C (female) cable that connects a NMEA2000 product to SimNet
24006413	SimNet to Micro-C female to SimNet 4 m (13 ft)
24006363	SimNet cable, 5.5 m (18 ft), with 1 plug

Ethernet cables

Part Number	Description
000-0127-55	Adapter cable: Ethernet Yellow male to RJ45 female 0.3 m (1 ft)
000-0127-56	Adapter cable: Ethernet Yellow male to RJ45 female 2 m (6.5 ft)
000-0127-51	Ethernet cable yellow 5 Pin 2 m (6.5 ft)
000-0127-29	Ethernet cable yellow 5 Pin 4.5 m (15 ft)
000-0127-30	Ethernet cable yellow 5 Pin 7.7 m (25 ft)
000-0127-37	Ethernet cable yellow 5 Pin 15.2 m (50 ft)

Supported data

NMEA 2000 PGN List

NMEA 2000 PGN (receive)

59392	ISO Acknowledgement
59904	ISO Request
60928	ISO Address Claim
61184	Parameter Request/Command
65285	Temperature with Instance
65289	Trim Tab Insect Configuration
65291	Backlight Control
65292	Clear Fluid Level Warnings
65293	LGC-2000 Configuration
65323	Data User Group Request
65325	Reprogram Status
65341	Autopilot Mode
65480	Autopilot Mode
126208	ISO Command Group Function
126992	System Time
126996	Product Info
127237	Heading/Track Control
127245	Rudder
127250	Vessel Heading
127251	Rate of Turn
127257	Attitude
127258	Magnetic Variation
127488	Engine Parameters, Rapid Update
127489	Engine Parameters, Dynamic
127493	Transmission Parameters, Dynamic
127503	AC input status
127505	Fluid Level
127506	DC Detailed Status
127508	Battery Status
128259	Speed, Water referenced
128267	Water Depth
128275	DistanceLog
129025	Position, Rapid Update
129026	COG & SOG, Rapid Update
129029	GNSS Position Data
129033	Time & Date
129038	AIS Class A Position Report
129039	AIS Class B Position Report
129040	AIS Class B Extended Position Report
129283	Cross Track Error
129284	Navigation Data
129539	GNSS DOPs
129540	GNSS Sats in View
129794	AIS Class A Static and Voyage Related Data
129801	AIS Addressed Safety Related Message

129802	AIS Safety Related Broadcast Message
129808	DSC Call Information
130074	Route and WP Service - WP List - WP Name & Position
130306	Wind Data
130310	Environmental Parameters
130311	Environmental Parameters
130312	Temperature
130313	Humidity
130314	Actual Pressure
130576	Small Craft Status
130577	Direction Data
130840	Data User Group Configuration
130842	SimNet DSC Message
130845	Parameter Handle
130850	Event Command
130851	Event Reply
130817	Product Info
130820	Reprogram Status
130831	Suzuki Engine and Storage Device Config
130832	Fuel Used - High Reolution
130834	Engine and Tank Configuration
130835	SetEngineAndTankConfiguration
130838	Fluid Level Warning
130839	Pressure Insect Configuration
130843	Sonar Status, Frequency and DSP Voltage

18

NMEA2000 PGN (transmit)

61184	Parameter Request/Command
65287	Configure Temperature INSOcts
65289	Trim Tab Insect Calibration
65290	Paddle Wheel Speed Configuration
65291	Backlight Control
65292	Clear Fluid Level Warnings
65293	LGC-2000 Configuration
126208	ISO Command Group Function
126992	System Time
126996	Product Info
127237	Heading/Track Control
127250	Vessel Heading
127258	Magnetic Variation
128259	Speed, Water referenced
128267	Water Depth
128275	DistanceLog
129025	Position, Rapid Update
129026	COG & SOG, Rapid Update
129029	GNSS Position Data
129283	Cross Track Error
129284	Navigation Data
129285	Route/Waypoint Data
129539	GNSS DOPs
129540	GNSS Sats in View
130074	Route and WP Service - WP List - WP Name & Position
130306	Wind Data
130310	Environmental Parameters
130311	Environmental Parameters
130312	Temperature
130577	Direction Data
130840	Data User Group Configuration
130845	Parameter Handle
130850	Event Command
130818	Reprogram Data
130819	Request Reprogram
130828	Set Serial Number
130831	Suzuki Engine and Storage Device Config
130835	SetEngineAndTankConfiguration
130836	Fluid Level Insect Configuration
130837	Fuel Flow Turbine Configuration
130839	Pressure Insect Configuration
130845	Weather and Fish Prediction and Barometric Pressure History
130850	Evinrude Engine Warnings

NMEA0183 supported sentences

TX / RX		GPS						
Receive	GGA	GLL	GSA	GSV	VTG	ZDA		
Transmit	GGA	GLL	GSA	GSV	VTG	ZDA		
		Navigation						
Receive	RMC							
Transmit	AAM	APB	BOD	BWC	BWR	RMC	RMB	XTE
		Echo						
Receive	DBT	DPT	MTW	VLW	VHW			
Transmit	DBT	DPT	MTW	VLW	VHW			
		Compass						
Receive	HDG	HDT	HDM					
Transmit	HDG							
		Wind						
Receive	MWV	MWD						
Transmit	MWV							
		AIS / DSC						
Receive	DSC	DSE	VDM	AIS sentences are not bridged to or from SimNet.				
		MARPA						
Transmit	TLL	TTM	These are only output sentences					

19

Specifications

Multi Function Display	NSS7	NSS8	NSS12
Display			
Display resolution	480 x 640 (H x W)	800 x 600 (H x W)	1024 x 768 (H x W)
Display type	6.4 inch VGA color TFT LCD	8 inch SVGA color TFT LCD	12.1 inch XGA TFT LCD
Display brightness	1200 nits	1200 nits	1200 nits
Touch screen		Yes	
Power			
Power supply	12 - 24 V DC (9-32.0 VDC min - max)	12 - 24 V DC (9-32.0V DC min - max)	12 - 24 V DC (9-32.0 VDC min - max)
Power consumption	10.4 W (0.8 A @ 13 V DC)	15.6 W (1.2 A @ 13 V DC)	26 W (2.0 A @ 13 V DC)
Technical / Environmental			
Housing	Plastic housing; Die cast rear heatsink		
Temperature	-15° C to + 55° C (+5° F to +131° F)		
Waterproof standard	IPx7		
Certificate of conformity	CE(EN60945: 2002) / C-tick / CSS		
Interface			
Ethernet	1 Port	1 Port	3 Ports
NMEA2000	Micro-C (1)		
Video input	Composite video (2) (multiplexed)		
Data card slot	Micro SD (1)		
Other			
Weight (display only)	1.6 kg (3.5 lb)	2.1 kg (4.6 lb)	3.78 kg (8.3 lb)
Pack dimensions (L x W x H)	30.5 x 27.9 x 27.9 cm (12" x 11" x 11")	40.6 x 27.9 x 25.4 cm (16" x 11" x 10")	
Pack weight	2.54 kg (5.6 lb)	2.9 kg (6.5 lb)	
Echo sounder			
Sonar frequency	50/200 or 83/200 kHz		
Sonar output power	Max 250 W peak to peak (31 W RMS) actual	Max 250 W peak to peak (31 W RMS) actual	Not applicable



LOWRANCE

SIMRAD

B&G

www.bandg.com
www.simrad-yachting.com
www.lowrance.com