



by **SonneMed**

Perfekte Verbindung!

Perfect connection

Hospital Doors



All specifications, models, versions shown are indicative, representative & approximate, and are subject to change without any prior notice with exclusive discretion of the original equipment manufacturer.



#Smart Solutions...
...since 1953!

Srishty Medical Private Limited

A 219
Road No.6
Mahipalpur NH-8
New Delhi-110037 INDIA

www.sngindia.org
customercare@sngindia.org
Mob. : +91 98100 07700





by **SonneMed**

Perfekte Verbindung!

Perfect connection



SMHD 1011

All specifications, models, versions shown are indicative, representative & approximate, and are subject to change without any prior notice with exclusive discretion of the original equipment manufacturer.



#Smart Solutions...
...since 1953!

Srishty Medical Private Limited

A 219
Road No.6
Mahipalpur NH-8
New Delhi-110037 INDIA

www.sngindia.org
customer@care@sngindia.org
Mob. : +91 98100 07700





by **SonneMed**

Perfekte Verbindung!

Perfect connection

AUTOMATIC HERMETIC SEAL DOORS

SMHD 1011



PRODUCT FEATURES

- 1 The track rail and door plate is mounted onto the wall,, it is easy for fast installation.
- 2 Adopting Owic exclusive high-tech patents (National Patent No.: ZL200520014092.5 ZL 200520014093.X), good hermetization that meets the highest grade 8 of national standards GB/T 7106-2008, will help effectively preventing cross infection and greatly enhancing the hygienic performance of hospitals.
- 3 Unique designed handles to reduce manual opening force when power failure.
- 4 Operating quietly and fast, good performance in sound insulation.
- 5 The feature of environmental protection and energy saving is realized by the strong door plate and effective opening and closing system that minimize the air flux, so that the cold air and dust will be isolated outside and the temperature and wetness inside room well kept.
- 6 Humanized barrier free design provides the max convenience and safety to the patients and wheel barrows.

SPECIFICATIONS

Door Leaf Weight	max 150KG
Door Width	DW=1070mm~1570mm
Opening Speed	250~550mm/s (Adjustable)
Closing Speed	250~550mm/s (Adjustable)
Open Delay Time	2~20s (Adjustable)
Closing Force	>70N
Manual Open Force	<100N
Power Consumption	<150W

Area of Application :

- ◆ Operating Rooms
- ◆ Isolation Rooms
- ◆ Critical Care Rooms / ICUs
- ◆ Laboratories / Clean Rooms
- ◆ Negative / Positive Air Pressurised Rooms
- ◆ Emergency Rooms

STRUCTRE

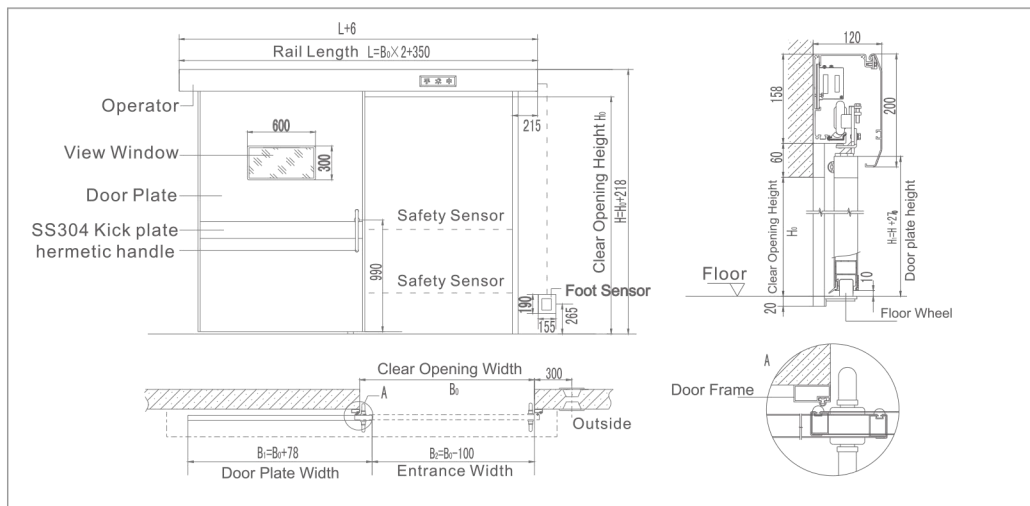

All specifications, models, versions shown are indicative, representative & approximate, and are subject to change without any prior notice with exclusive discretion of the original equipment manufacturer.



#Smart Solutions...
...since 1953!

Srishty Medical Private Limited

A 219
Road No.6
Mahipalpur NH-8
New Delhi-110037 INDIA

www.sngindia.org
customercare@sngindia.org
Mob : +91 98100 07700





by **SonneMed**

Perfekte Verbindung!

Perfect connection



SMHD 1012

All specifications, models, versions shown are indicative, representative & approximate, and are subject to change without any prior notice with exclusive discretion of the original equipment manufacturer.



#Smart Solutions...
...since 1953!

Srishty Medical Private Limited

A 219
Road No.6
Mahipalpur NH-8
New Delhi-110037 INDIA

www.sngindia.org
customercare@sngindia.org
Mob : +91 98100 07700





by **SonneMed**

Perfekte Verbindung!

Perfect connection

AUTOMATIC HERMETIC SEAL DOORS

SMHD 1012

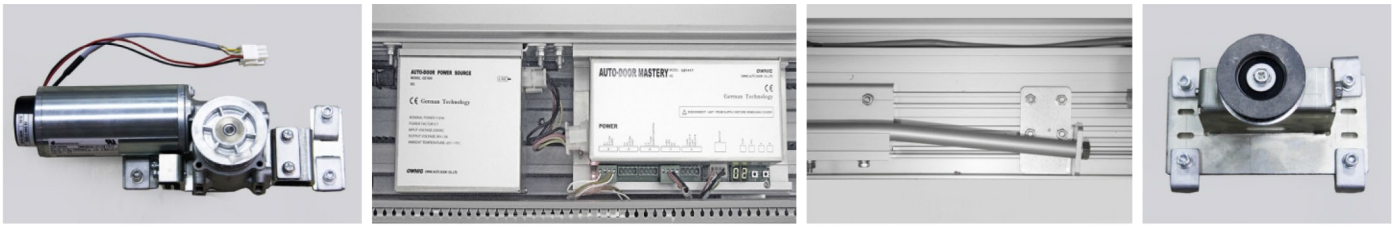

PRODUCT FEATURES

- German Dunker brush motor is introduced into the series, even longer life span, higher efficiency and Maintenance free.
- The track rail is mounted directly onto the wall, of easy installation and good-looking appearance.
- The unique hermetization operating structure and air pressing technology obtained the National Patent No. 201110293268.5, 201110294124.1, and the good hermetization meet the highest grade 8 of national standards GB/T 7106-2008.
- Unique sinking structure of max 15mm downwards and 10mm inwards to make sure the door plate is tightly pressing the floor and frames, greatly enhanced the performance of hermetization.
- Operating quietly and fast, good performance in sound insulation.
- The features of environmental protection and energy saving is realized by the strong door plate and effective opening and closing system that minimize the air flux, so that the cold air and dust will be isolated outside and the temperature and wetness inside room well kept.
- Humanized barrier free design provides the max convenience and safety to the patients and wheel barrows.

SPECIFICATIONS

Opening Speed	250~550mm/s (Adjustable)
Closing Speed	250~550mm/s (Adjustable)
Open Delay Time	2~20s (Adjustable)
Closing Force	>70N
Manual Open Force	<100N
Power Consumption	<150W

Area of Application :

- ◆ Operating Rooms
- ◆ Isolation Rooms
- ◆ Critical Care Rooms / ICUs
- ◆ Laboratories / Clean Rooms
- ◆ Negative / Positive Air Pressurised Rooms
- ◆ Emergency Rooms

STRUCTRE

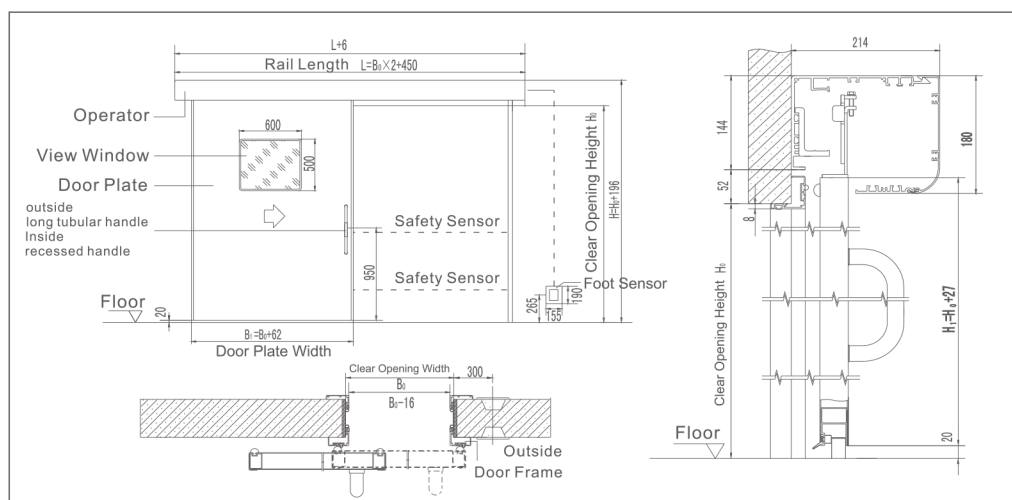

All specifications, models, versions shown are indicative, representative & approximate, and are subject to change without any prior notice with exclusive discretion of the original equipment manufacturer.



Srishty Medical Private Limited

A 219
Road No.6
Mahipalpur NH-8
New Delhi-110037 INDIA

www.sngindia.org
customercare@sngindia.org
Mob. : +91 98100 07700





by **SonneMed**

Perfekte Verbindung!

Perfect connection



SMHD 2012

All specifications, models, versions shown are indicative, representative & approximate, and are subject to change without any prior notice with exclusive discretion of the original equipment manufacturer.



#Smart Solutions...
...since 1953!

Srishty Medical Private Limited

A 219
Road No.6
Mahipalpur NH-8
New Delhi-110037 INDIA

www.sngindia.org
customer@care@sngindia.org
Mob. : +91 98100 07700





AUTOMATIC HERMETIC DOUBLE DOOR

SMHD 2012



PRODUCT FEATURES

- ❶ Both on-wall type and built-in type are available. The track rail is mounted on/into the wall, of easy installation and good-looking appearance.
- ❷ Control system is designed in accordance with the safety requirements of medical electrical system, and also multiform control modes could be adopted according to the hospital requirements, that will not cause electromagnetic interference to other equipments at the same location;
- ❸ Security sensors are adopted to automatically detect if there any obstacles when the door is closing and keep the door opening to ensure the safety of passengers or equipments.
- ❹ Whenever obstructions happened during operation, the door will rebound automatically to ensure the safety of passengers.
- ❺ Operating quietly and fast, the sound insulation effect is good.

SPECIFICATIONS

Opening Speed	250~550mm/s (Adjustable)
Closing Speed	250~550mm/s (Adjustable)
Open Delay Time	2~20s (Adjustable)
Closing Force	>70N
Manual Open Force	<100N
Power Consumption	<150W

Area of Application :

- ◆ Critical Care / ICUs
- ◆ Emergency Rooms
- ◆ Negative / Positive Air Pressurised Rooms
- ◆ Corridors / Air Barriers

STRUCTRE

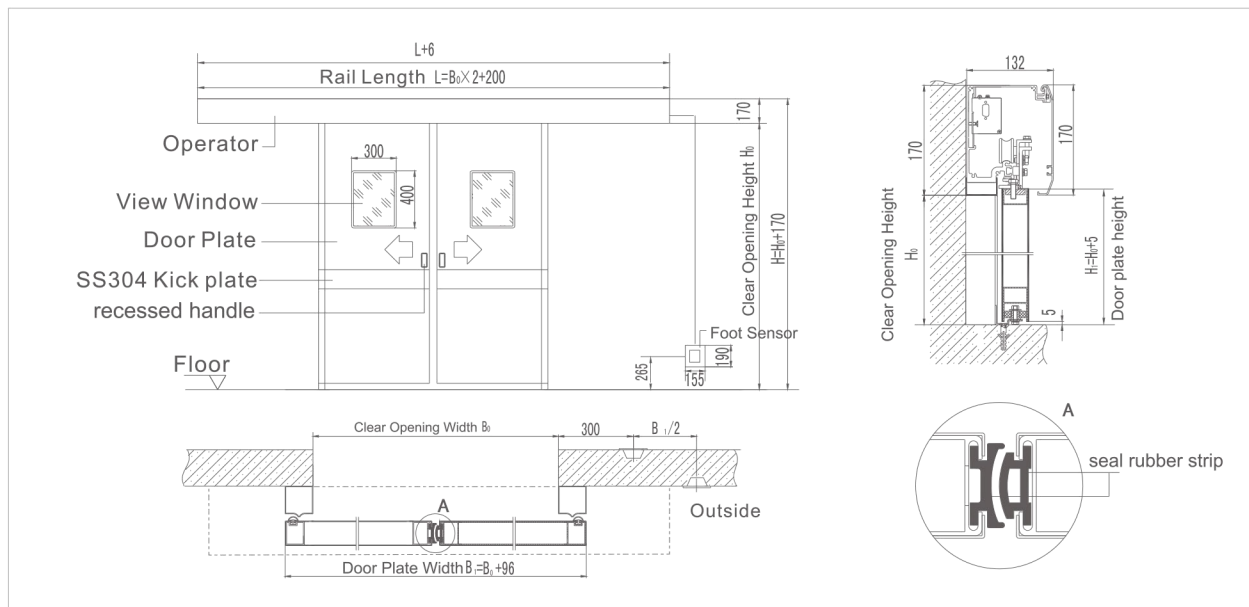

All specifications, models, versions shown are indicative, representative & approximate, and are subject to change without any prior notice with exclusive discretion of the original equipment manufacturer.





by **SonneMed**

Perfekte Verbindung!

Perfect connection



SMHD 1011X

All specifications, models, versions shown are indicative, representative & approximate, and are subject to change without any prior notice with exclusive discretion of the original equipment manufacturer.



#Smart Solutions...
...since 1953!

Srishty Medical Private Limited

A 219
Road No.6
Mahipalpur NH-8
New Delhi-110037 INDIA

www.sngindia.org
customercare@sngindia.org
Mob. : +91 98100 07700





AUTOMATIC HERMETIC X-RAY SHIELDING

SMHD 1011X

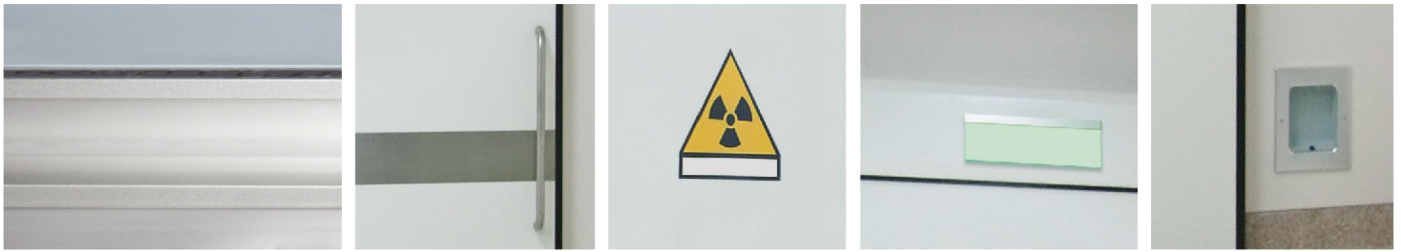

PRODUCT FEATURES

- 1 Pb sheet is inside the door plate to shield the X-rays and protect human body against a variety of harmful rays. Light type with Pb thickness 1mm~3mm, and heavy type 4mm~6mm.
- 2 The X-ray shielding doors have passed the inspection of the Institution of Radiation Protection and Nuclear Safety of Chinese Center for Disease Control and Prevention, and meet the requirements of X-ray protection. (Radioprotection No. 2006-087);
- 3 Rubber seal strips are installed in the door frames and operator, which will meet the hygienic requirements of hospitals and other places.
- 4 The Control system is designed in accordance with the safety requirements of medical electrical system, and also multiform control modes could be adopted according to the hospital requirements, that will not cause electromagnetic interference to other equipments at the same location;
- 5 Both automatic sliding doors and hermetic sliding doors could be made to this kind of doors.

SPECIFICATIONS

Opening Speed	250~550mm/s (Adjustable)
Closing Speed	250~550mm/s (Adjustable)
Open Delay Time	2~20s (Adjustable)
Closing Force	>70N
Manual Open Force	<100N
Power Consumption	<150W

Area of Application :

- ◆ Radiology Department
- ◆ CT / MRI Rooms
- ◆ Nuclear Radiology / Nuclear Medicine

STRUCTRE

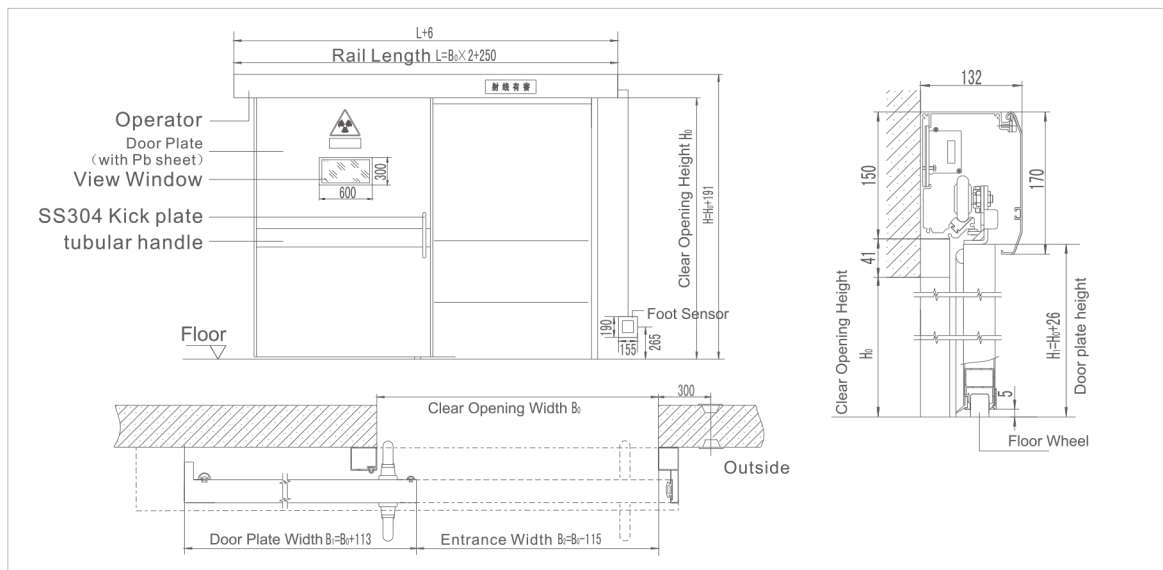

All specifications, models, versions shown are indicative, representative & approximate, and are subject to change without any prior notice with exclusive discretion of the original equipment manufacturer.





by **SonneMed**

Perfekte Verbindung!

Perfect connection



SMHD 1011G

All specifications, models, versions shown are indicative, representative & approximate, and are subject to change without any prior notice with exclusive discretion of the original equipment manufacturer.



#Smart Solutions...
...since 1953!

Srishty Medical Private Limited

A 219
Road No.6
Mahipalpur NH-8
New Delhi-110037 INDIA

www.sngindia.org
customercare@sngindia.org
Mob. : +91 98100 07700





by **SonneMed**

Perfekte Verbindung!

Perfect connection

AUTOMATIC HERMETIC SEAL GLASS DOOR # SMHD 1011G



PRODUCT FEATURES

- ① The door leaves are made by alum alloy powder coated frames or SS304 matt finish frames and large tempered glass 10mm~12mm, easy for the installation
- ② Operating quietly and fast, good sound insulation performance.
- ③ The door is designed for ICU, senior ward, laboratory, and other places of less passenger flowrate and quiet environment.
- ④ A variety control modes can be adopted, such as infrared sensors, foot sensors, key card readers, etc.

SPECIFICATIONS

Opening Speed	250~550mm/s (Adjustable)
Closing Speed	250~550mm/s (Adjustable)
Open Delay Time	2~20s (Adjustable)
Closing Force	>70N
Manual Open Force	<100N
Power Consumption	<150W

Area of Application :

- ◆ Isolation Rooms
- ◆ Critical Care Rooms / ICUs
- ◆ Negative / Positive Air Pressurised Rooms
- ◆ Emergency Rooms
- ◆ Corridors / Air Barriers
- ◆ Laboratories & Clean Rooms

STRUCTRE

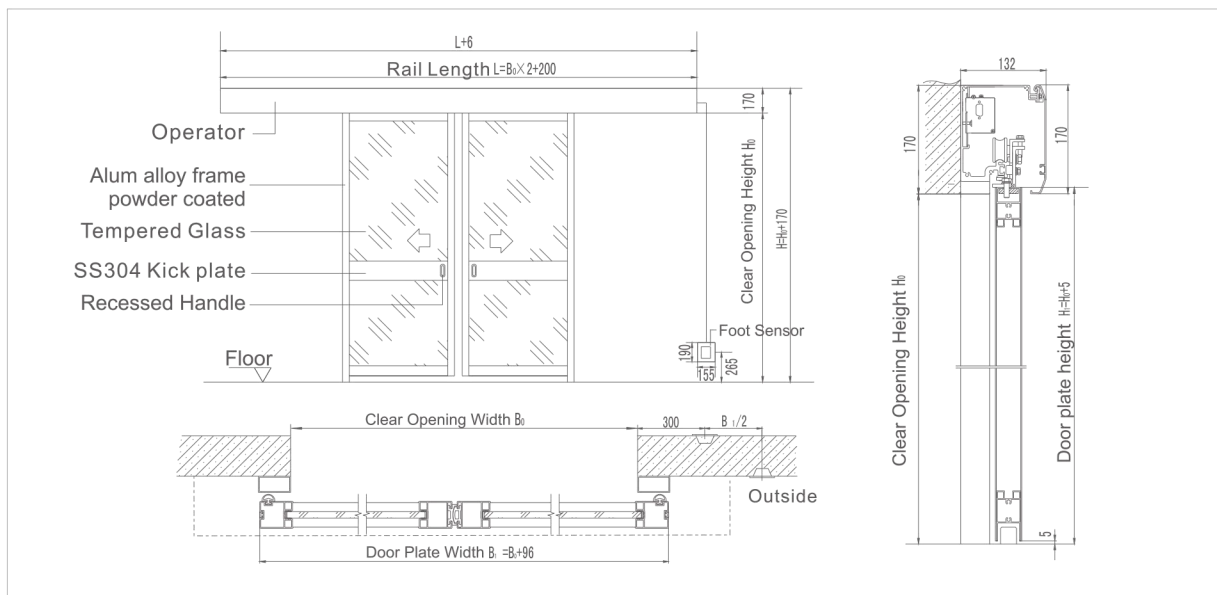

All specifications, models, versions shown are indicative, representative & approximate, and are subject to change without any prior notice with exclusive discretion of the original equipment manufacturer.



#Smart Solutions...
...since 1953!

Srishty Medical Private Limited

A 219
Road No.6
Mahipalpur NH-8
New Delhi-110037 INDIA

www.sngindia.org
customercare@sngindia.org
Mob. : +91 98100 07700





by **SonneMed**

Perfekte Verbindung!

Perfect connection



SMHD 2012S

All specifications, models, versions shown are indicative, representative & approximate, and are subject to change without any prior notice with exclusive discretion of the original equipment manufacturer.



#Smart Solutions...
...since 1953!

Srishty Medical Private Limited

A 219
Road No.6
Mahipalpur NH-8
New Delhi-110037 INDIA

www.sngindia.org
customer@care@sngindia.org
Mob. : +91 98100 07700





by **SonneMed**

Perfekte Verbindung!

Perfect connection

AUTOMATIC HERMETIC SEAL SWING DOOR

SMHD 2012S

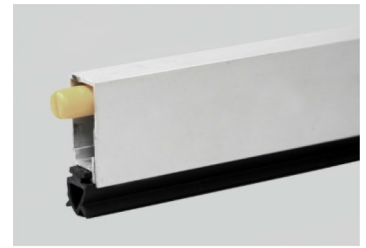
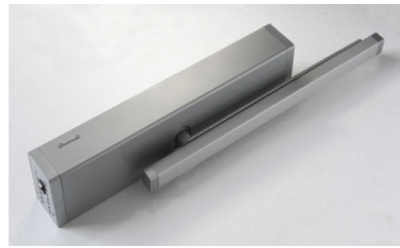

PRODUCT FEATURES

- Both Sliding arm type and articulated arm type are available.
- Operating system adopts microcomputer chip to intelligently control the door and the open angle could be adjusted at any position.
- The operator is directly mounted onto the wall, easy and fast for installation.
- A variety control modes can be adopted, such as infrared sensors, foot sensors, key card readers, etc.
- Door plate is made of high-intensity aluminium alloy structure and high quality environmental filling material.
- Along the door frames and the bottom there are rubber seal strips working together to well meet the sanitary requirements of hospitals, nurse stations and clean workshops, etc.

SPECIFICATIONS

Opening Angle	0° ~ 110°
Door Width	max 150KG
Opening Time(90°)	2s~4s
Closing Time(90°)	2s~4s
Open Delay Time	1~20s (Adjustable)
Manual Open Force	< 100N
Power Consumption	< 150W

Area of Application :

- ◆ Isolation Rooms
- ◆ Critical Care Rooms / ICUs
- ◆ Negative / Positive Air Pressurised Rooms
- ◆ Emergency RoomsL
- ◆ Corridors / Air Barriers
- ◆ Laboratories & Clean Rooms

STRUCTRE

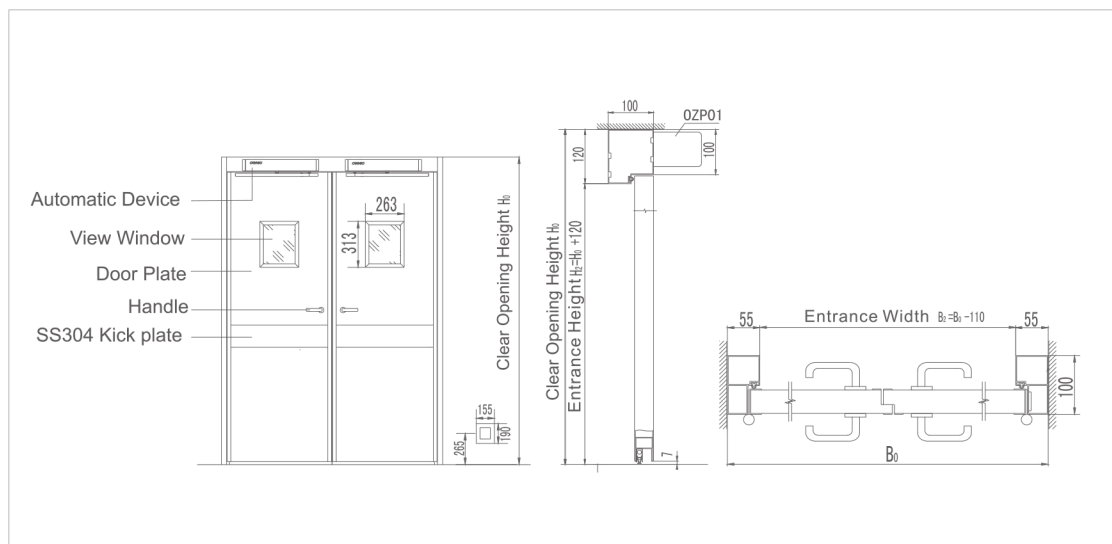

All specifications, models, versions shown are indicative, representative & approximate, and are subject to change without any prior notice with exclusive discretion of the original equipment manufacturer.



Srishty Medical Private Limited

A 219
Road No.6
Mahipalpur NH-8
New Delhi-110037 INDIA

www.sngindia.org
customercare@sngindia.org
Mob. : +91 98100 07700





by **SonneMed**

Perfekte Verbindung!

Perfect connection



SMHD 4000

All specifications, models, versions shown are indicative, representative & approximate, and are subject to change without any prior notice with exclusive discretion of the original equipment manufacturer.



#Smart Solutions...
...since 1953!

Srishty Medical Private Limited

A 219
Road No.6
Mahipalpur NH-8
New Delhi-110037 INDIA

www.sngindia.org
customercare@sngindia.org
Mob. : +91 98100 07700





by **SonneMed**

Perfekte Verbindung!

Perfect connection

AUTOMATIC FOLDING DOOR

SMHD 4000



PRODUCT FEATURES

- ❶ The door is suitable for places of space limited and makes the maximum space utilization.
- ❷ The door frames and operator is sealed with rubber seal, that will well meet the hygienic requirements of hospitals, nurses' station, purification factories, etc.
- ❸ Various access modes are available, such as infrared sensors, microwave sensors, and entrance guard systems, etc.
- ❹ The door leaves could be made from aluminium alloy frames and large plane glass that enhanced the lighting.

SPECIFICATIONS

Door Type	4 Leaves
Max Width	800mm~2200mm
Door Height	2000mm~2200mm
Opening Speed	Adjustable
Closing Speed	Adjustable
Open Delay Time	1~20s (Adjustable)
Power Consumption	<30W
Working Temperature	-20°C ~ +50°C

Area of Application :

- ◆ Corridors / Air Barriers

STRUCTURE

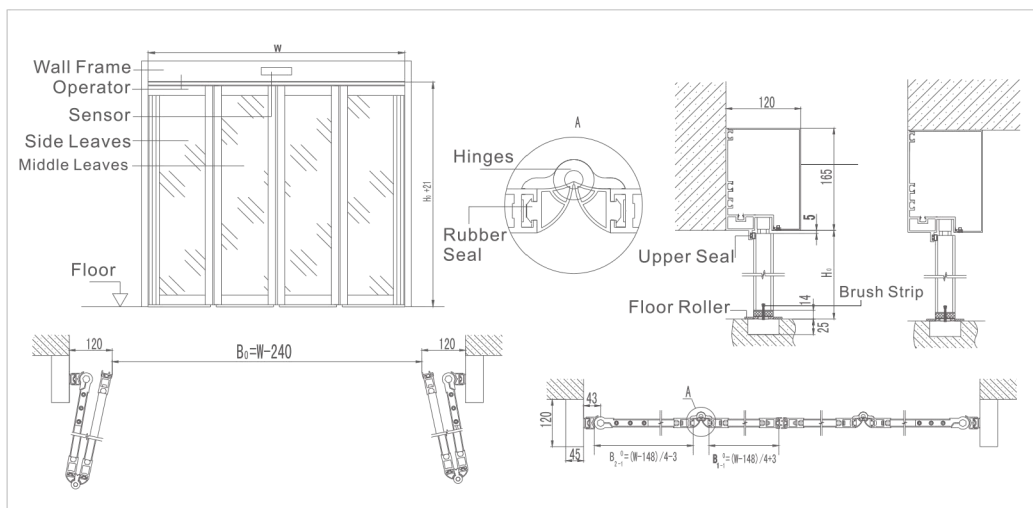

All specifications, models, versions shown are indicative, representative & approximate, and are subject to change without any prior notice with exclusive discretion of the original equipment manufacturer.



#Smart Solutions...
...since 1953!

Srishty Medical Private Limited

A 219
Road No.6
Mahipalpur NH-8
New Delhi-110037 INDIA

www.sngindia.org
customer@sgindia.org
Mob. : +91 98100 07700





AUTOMATIC DOOR CONTROL UNIT

SMHD 01

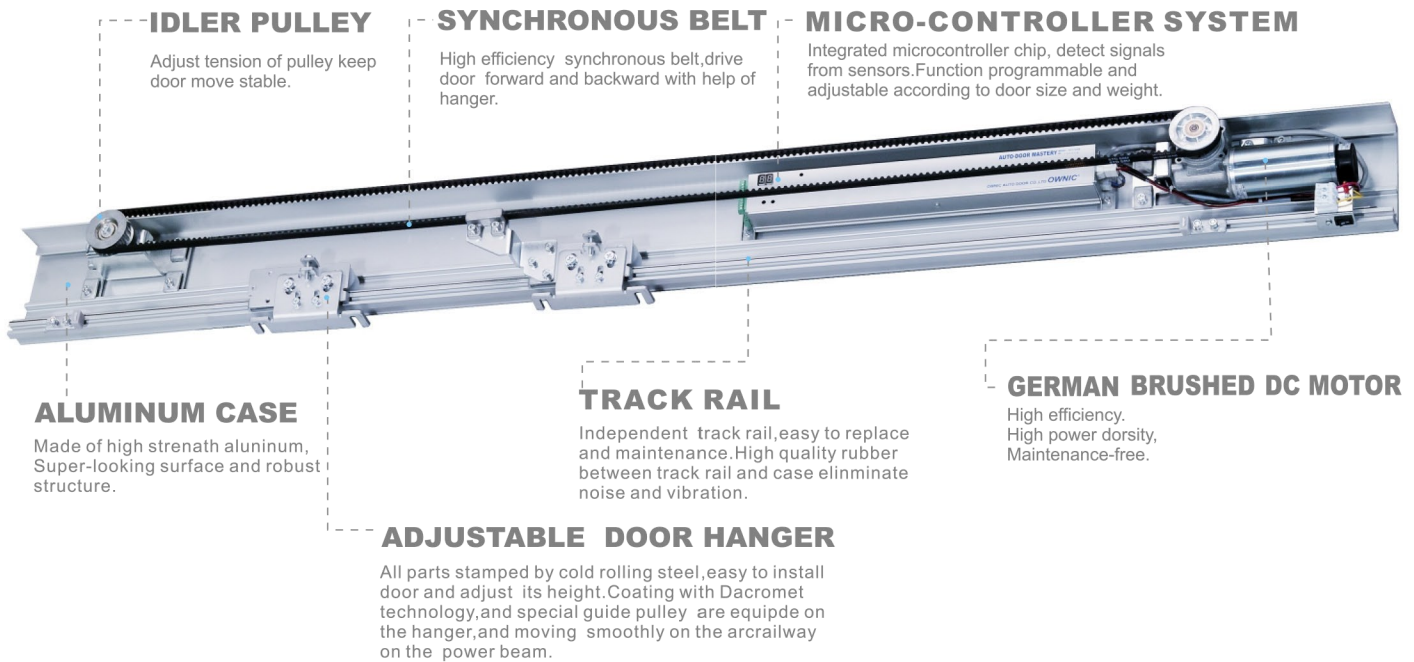

PRODUCT FEATURES

- 1 German brushed DC motor of long life span, high efficiency.
- 2 The auto door operator is designed to run in a wide voltage range which ensures a more reliable operation of the whole drive unit.
- 3 The door leaf will automatically turn back if it touches any obstacles when it is moving, so it is safer for users.
- 4 The operator can automatically adapt itself to different doors weights.
- 5 The slow running distance in the process of opening or closing can be adjusted automatically.
- 6 The motor is designed with unique lock function, then the doors can be locked without mechanical locks.
- 7 Faster Opening speed, more humanization.

SPECIFICATIONS

DOOR WEIGHT	SINGLE 150Kg	DOUBLE 150Kg X2	
DOOR WIDTH	700mm~2100mm	650mm~1050mm	
OPENING SPEED	250 ~ 550mm/s		
CLOSING SPEED	250 ~ 550mm/s	REVERSE TIME	≤1S
DELAY FOR OPENING	2 ~ 20S	POWER VOLTAGE	AC220V ± 10%, 50HZ
DOOR CLOSE LOCK FORCE	≥500N	WORK TEMPERATURE	-20°C ~ +50°C

All specifications, models, versions shown are indicative, representative & approximate, and are subject to change without any prior notice with exclusive discretion of the original equipment manufacturer.



Srishty Medical Private Limited

A 219
Road No.6
Mahipalpur NH-8
New Delhi-110037 INDIA

www.sngindia.org
customercare@sngindia.org
Mob. : +91 98100 07700

