



AIR QUALITY ENGINEERING

Tailored solutions from people who care



Air Quality Solutions for Commercial Kitchen Exhaust

▶ **AUTOCLEAN® (F61) and SMOKEMASTER® (F72) Series In-Duct Air Filtration**

Air Quality Solutions from People Who Care

Air Quality Engineering, Inc. is a personable, responsive and independently-owned U.S. company with a single focus of providing indoor air quality solutions delivered with a unique commitment to customer care. Since 1973, we've applied our engineering expertise to the design and manufacturing of high-quality air cleaning systems.

Air Quality Engineering, Inc.'s company-based and local air quality dealers and distributors, both in the U.S. and worldwide, work hard to understand your specific concerns and goals. We then recommend and deliver the ideal clean air solution, tailored as needed, for your application.

Our People, Processes and Products

People

- Call our engineers, managers and air quality experts and receive prompt answers to your questions.
- Engineers specialized in:
 - Design
 - Product development
 - Product engineering
 - Applications
- We'll go the extra mile for you – before and after the installation of your new air cleaning system.

Processes

- Our consultative selling approach ensures we first understand your needs and then recommend a system that will solve your commercial kitchen exhaust air purification needs.
- The range of products and technologies available from Air Quality Engineering, Inc. enables us to recommend the ideal air cleaning system for your application.
- We build and strengthen our working relationship with you based on providing honest air cleaning system performance data.



Products

We design and manufacture our own high-quality air cleaning systems, including sheet metal fabrication, using state-of-the-art equipment and lean manufacturing that:

- Provides quality control
- Increases manufacturing speed and product lead time
- Allows for project-specific design and manufacturing customization
- Is provided by a woman-owned, U.S. manufacturing company



Manufacturers Alliance
Sharing Education & Resources Peer to Peer



How Electrostatic Filtration Works

Electronic air cleaning systems use one or more permanent electronic collector cells or filters featuring electrostatic precipitation technology to collect and remove smoke, grease and other harmful contaminants in commercial kitchen hood exhaust.

An electronic collector cell is composed of an ionizing or charging section and a collection section. Incoming contaminant particles pass through an intense ionization field in the charging section. The ionization causes the particles to lose electrons and acquire a positive electrical charge.

In the collection section, positively charged metal plates or fins repel the positively charged particles, and alternating grounded fins attract the positively charged particles.

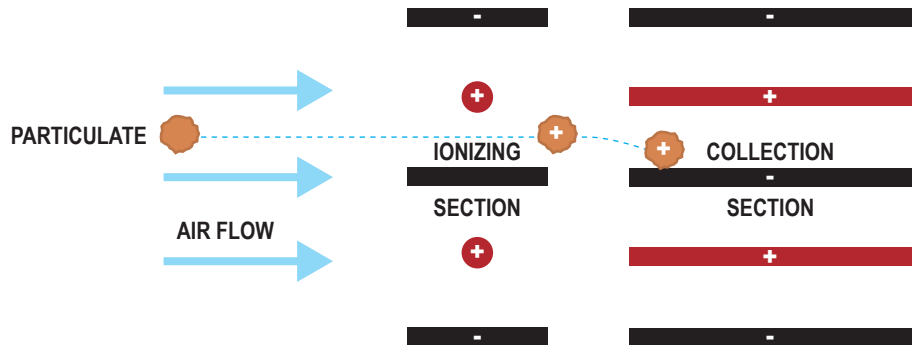

Contaminants remain trapped on the grounded fins until the collector cell is washed.



Skidded AUTOCLEAN® 4000 Unit with Odor Control Module

Highly Efficient Capture of Harmful Airborne Contaminants

Air Quality Engineering, Inc. designs and manufactures the AUTOCLEAN® and SMOKEMASTER® F72 family of commercial kitchen exhaust air cleaning systems for the in-duct capture of smoke, grease and odor generated by restaurant and cafeteria cooking equipment.

Our systems are located downstream from the kitchen exhaust hoods and clean the air before it is released into the outdoor atmosphere. Our equipment is typically installed in the ceiling or mounted on the rooftop, but our compact size allows for location flexibility.

The AUTOCLEAN® and SMOKEMASTER® F72 product lines are highly efficient at collecting and removing harmful cooking contaminant utilizing electrostatic precipitation. Options include: Detergent and detergent tank; odor control modules with media safety filters and activated carbon to remove vapors and cooking odors; double-pass precipitator and/or odor control module sections; dual power packs for high efficiency; blower, motor, VFD and controls packages; skid mounting and weatherproof outdoor enclosures; kitchen-mounted Human Machine Interface (HMI) for remote control of the on-board Programmable Logic Controller (PLC).

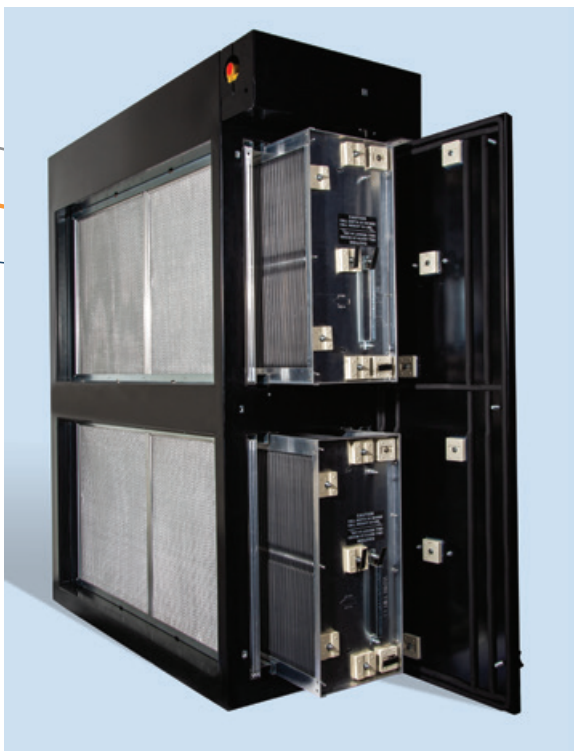

High Capacity and Small Footprint.
The AUTOCLEAN® 8000.

Product Line Features

- Programmable Logic Controller (PLC) for touchscreen operation. Standard on AUTOCLEAN®, optional on SMOKEMASTER® F72
- Premium self-wash cycle allows for frequent electrostatic cell cleaning, which optimizes performance
- Among the smallest in overall system footprint size
- Unique traversing and rotating wash arms that feature high-velocity spray nozzles delivering best in class self-cleaning results
- Green performance: The units are highly energy efficient, minimizing electrical expenses. The environmentally-friendly washable filters eliminate the expensive purchase and landfill loading disposal of replacement filters
- Superior quality and construction drastically reduces system down time, maintenance and cost of ownership
- Stackable customized modules provide design and installation flexibility for almost any size installation
- Up to 99% efficiency to ensure clean air
- Unique design will never block airflow through the kitchen hoods and therefore, will never shut down the kitchen cooking operations
- Easily reversible for filter access on either side

Touch Screen Display



Optional Human Machine Interface (HMI) for Remote Control of
AUTOCLEAN® and SMOKEMASTER®



Outdoor Rooftop Turnkey Unit Fully Assembled and Enclosed.

Let's Keep it Clean!

For the ultimate convenience and efficiency, we provide our top-line precipitator system AUTOCLEAN® with a fully automated wash system; it works hard so you don't have to.

The workhorse behind the brilliant sparkle delivered by AUTOCLEAN® is our mechanical wash mechanism. Simple in design but remarkably effective, our wash arms are designed to both rotate and traverse the entire cell cavity, allowing the detergent and rinse water to be delivered by high velocity nozzles. Our laser-focused nozzles spray away even the most stubborn grease and contaminant.

Our competitors utilize fixed nozzles that need to employ a wide cone-type spray pattern in order to cover the large cell bay area. As you know from using a garden sprayer, the wider the spray, the less the impact. Wide conic spray patterns are a great choice for protecting delicate flowers while watering the garden, but are not so effective when you need to hose down built up kitchen grease! AUTOCLEAN® is the clear choice.

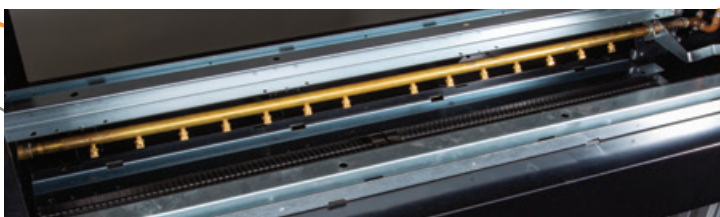

AUTOCLEAN® Rotating and Traversing Wash Nozzles.

One Impressive Package!

Our AUTOCLEAN® and SMOKEMASTER® F72 can be delivered as full factory-assembled turn-key units. They are custom configurable to include any or all of the following components; manual and/or auto-wash precipitator(s), odor control module(s), blowers, motors, VFDs, controls, skids and enclosures. The precipitator(s) and odor control module(s) are stackable and available in single or multi-pass configurations to achieve the desired efficiency and/or maintenance interval of almost any project. The units are:

- Single point wired, the only field wiring required is the three-phase supply to our NEMA enclosure along with field supplied accessories
- Fully factory assembled for ease of install and quality assurance
- Provided with 6" steel skids and available with weatherproof outdoor enclosures for durability and structural integrity
- Provided with lifting lugs for ease and safety in rigging
- Painted AFTER the units are skidded and welded to ensure long-lasting corrosion resistance and durability
- Factory tested as a full system to ensure performance, fitness and quality

Electrostatic Cell

Shown with Cell Access Door Open

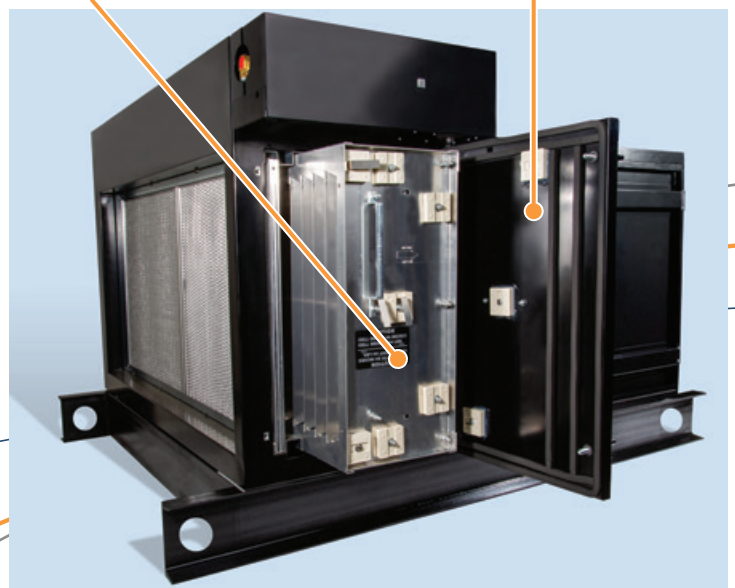

Skidded AUTOCLEAN® 4000 with Odor Control Module for Indoor Installations.



AUTOCLEAN® 2000

Green for a Better Tomorrow

Our kitchen exhaust air cleaning systems are a greener solution for the end user. Yes, we clean the exhaust from kitchens and remove up to 99% of cooking contaminant, which is great for the environment and cuts down on air pollution, but did you know that our units provide other green benefits?

Consider the Following:

- Beyond air cleaning, our system is eco-friendly because the pre- and postfilters and the electronic cells in the AUTOCLEAN® and SMOKEMASTER® F72 are all washable and reusable; our advanced technology prevents tons of soiled media filters from going into landfills.
- By design, precipitators use very little power and add much less static pressure to the exhaust system when compared to media-based systems; this allows for a blower motor with lower horsepower and results in a more energy efficient overall system.
- Because we eliminate those expensive media-based filters, your wallet will be much greener as well!

Small Footprint, **HUGE** Performance

Our design engineers know that space for mechanical systems is often very limited or restricted. It was with that in mind that they created the AUTOCLEAN® and SMOKEMASTER® F72 series of precipitators.

Our design ensures that these units deliver the utmost in efficiency and durability with the smallest footprint possible. Made from high-grade, long-lasting materials using quality controlled manufacturing processes, our kitchen exhaust air cleaners are built with a pride of workmanship that is rare in today's world.

Odor Control Module

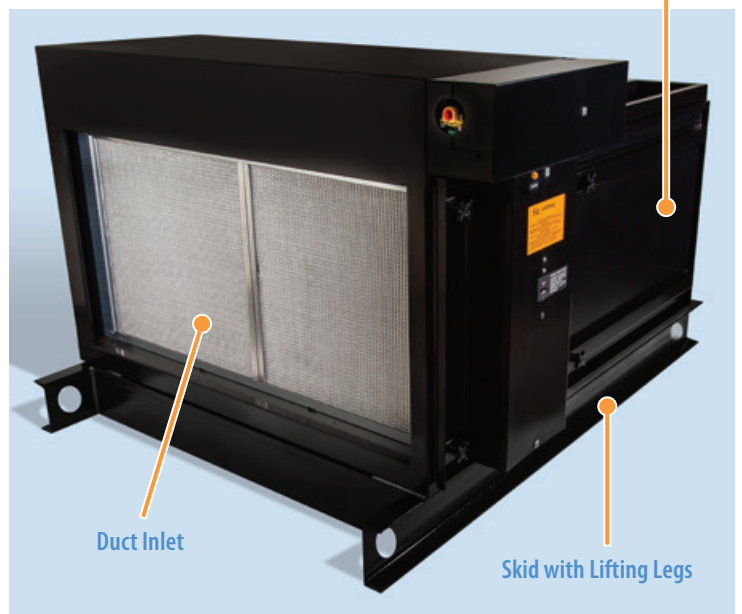

Duct Inlet

Skid with Lifting Legs

Skidded AUTOCLEAN® 4000 with Odor Control Module for Indoor Installations.

The key to our compact design is our industrial electronic cell. This marvel of technology is small but powerful, delivering high efficiency at large volume cubic feet per minute (CFM) with a very compact cell size – performance that sets us apart from the competition.

Odor Control Modules

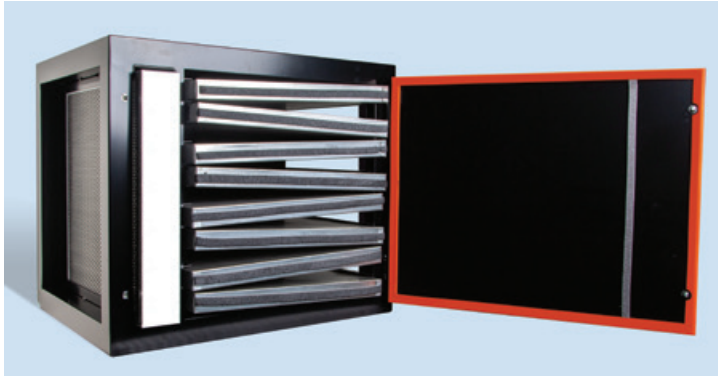

*Odor Control Module for SMOKEMASTER® and AUTOCLEAN® 2000
Shown with Door Open.*

The Air Quality Engineering, Inc. odor control module is a side access housing that contains bulk refillable trays of sorbent media for odor control. The “V” configuration of the trays allows for more sorbent media mass, higher efficiency, longer service life and lower static pressure add. The modules are available in standard 2000, 4000 and 8000 CFM sizes and are stackable to meet the needs of higher CFM projects.

- 100% virgin coconut shell carbon used for efficient and effective odor removal (potassium permanganate blends are available)
- MERV 14 (95% DOP) heavy-duty safety prefilters come standard
- Manufactured from 16 gauge cold rolled steel with an electrostatically-charged, multi-layered powder coat enamel finish
- Panels are bulk refillable
- Module is reversible for access on either side

Controls Packages

We will provide the necessary controls and factory-wire them for your convenience. This includes a magnetic contactor, thermal protection, main disconnect and all internally required control transformers housed in a NEMA enclosure. The controls will be prewired to interlock the fan motor to the precipitator and will include an HMI remote PLC controller. If desired, VFDs and soft starters are available. The controls package eliminates all necessary field wiring except for the supply (three-phase power) and any field supplied accessories. The controls are:

- Custom configurable
- Available in 208v, 230v or 460/480v
- Supplied with a remote mounted touch-screen HMI controller
- Supplied with inputs for: low detergent sensor, heat activated hood controls, BMS initiated wash and fire suppression systems

Fans and Motors

Air Quality Engineering, Inc. (AQE) offers optional fans and motors to go with your custom kitchen exhaust air cleaning system. The fan and motor will be factory selected to work in perfect harmony with your exhaust hoods and the AQE filtration system. Our fans and motors are:

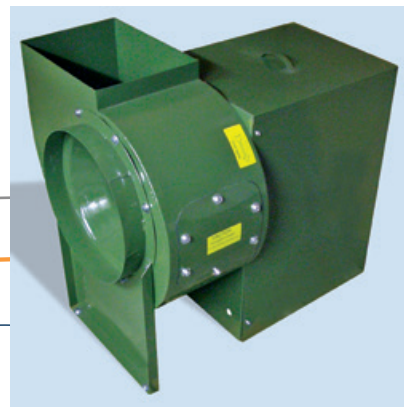

Typical Utility Set Blower

- UL762 listed (restaurant models)
- Available in utility set or in-line mixed flow units
- VFD rated
- Steel housed with all-welded construction
- Available with controls packages

Skid Mounting and Weatherproof Outdoor Enclosures

Air Quality Engineering, Inc. can provide the AUTOCLEAN®, SMOKEMASTER® F72 and Odor Control Module product lines pre-assembled, mounted and welded on 6" steel skids with lifting lugs. This skidded system can be adapted for outdoor placement with our custom made, weatherproof enclosure. The skids and enclosures feature:

- Customized design for each unique project
- Steel construction for superior rigidity and long life
- Sturdy access doors with premium gasketing

The skids allow for precise factory assembly of the chosen individual purification components, ease in rigging and safety in transportation to the jobsite.

The weatherproof outdoor enclosure keeps the electrical and system components dry and protected from the outdoor elements.

Detergent and Detergent Tanks

Air Quality Engineering, Inc. provides a detergent proven to be effective in kitchen exhaust applications. Cell cleaning detergent is precisely concentrated to ensure an ideal mixture when automatically diluted by the AUTOCLEAN® wash system. A detergent tank is available, featuring:

- Space-saving design allowing for flexible placement including inside the weatherproof outdoor enclosure
- Includes low detergent sensor
- Sturdy UV stabilized polyethylene construction

20-Gallon

- Capacity that will hold enough detergent to perform up to 400 AUTOCLEAN® wash cycles
- 35" x 11.5" x 11.5" overall dimensions
- 9 pounds when empty and approximately 190 pounds when full of AUTOCLEAN® cell detergent

15-Gallon

- Capacity that will hold enough detergent to perform up to 300 AUTOCLEAN® wash cycles
- 26 7/8" x 11.5" x 11.5" overall dimensions
- 8 pounds when empty and approximately 144 pounds when full of AUTOCLEAN® cell detergent

Multi-Pass, Stacked and Side-by-Side Configurations

Air Quality Engineering, Inc. can provide the AUTOCLEAN®, SMOKEMASTER® F72 and Odor Control Module product lines in a variety of configurations. The units can be stacked and/or placed side by side for additional CFM capacity. Multi-pass is an option if you desire additional efficiency and/or redundancy in the precipitator or odor control sections. Our engineers and trained experts can review your project and make recommendations based on:

- CFM through the exhaust hood
- Unique dimensional requirements
- Budget
- Desired efficiency and maintenance interval

Designs, drawings and specifications for custom systems are available.

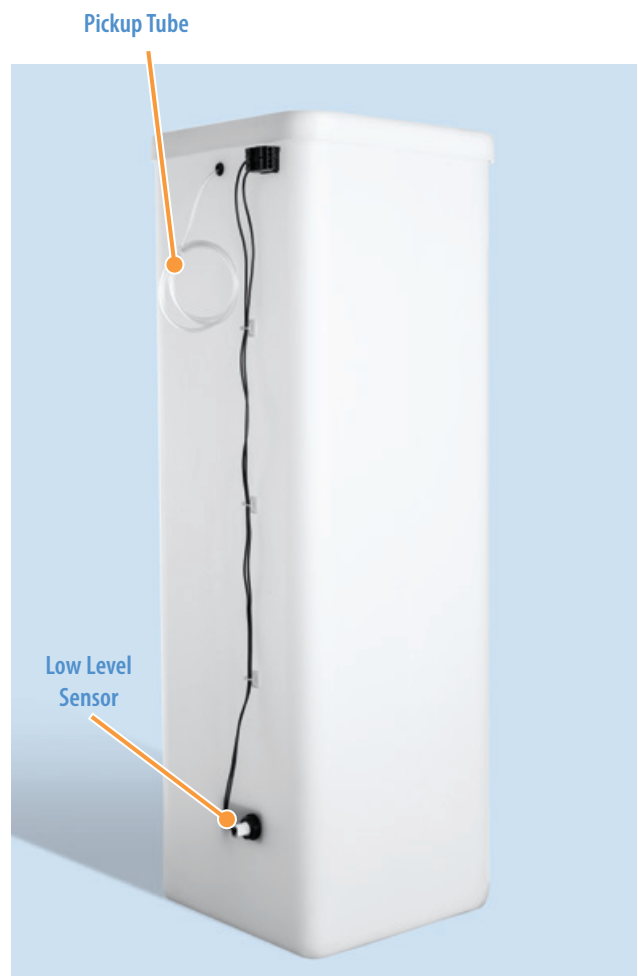

20-Gallon Detergent Tank with Lid

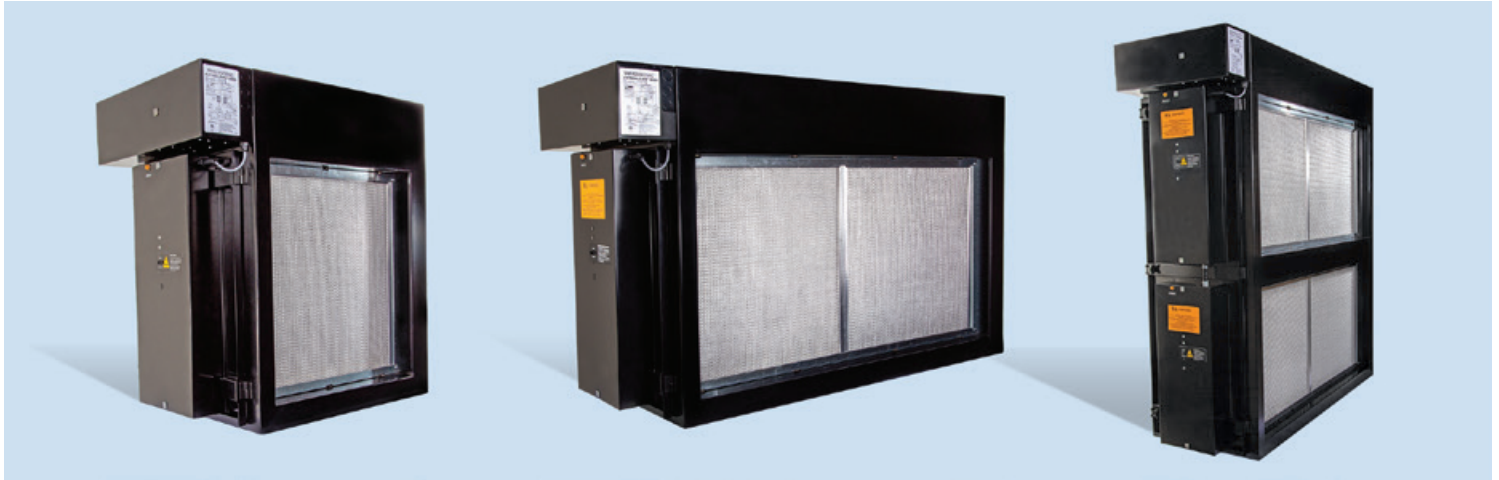

AUTOCLEAN® Automated Self-Cleaning Electrostatic Precipitators

Model	AUTOCLEAN® 2000				AUTOCLEAN® 4000				AUTOCLEAN® 8000			
Primary Filter	Washable electrostatic								Washable electrostatic			
Airflow (Cfm)	1500 CFM	2000 CFM	2500 CFM	3000 CFM	3000 CFM	4000 CFM	5000 CFM	6000 CFM	6000 CFM	8000 CFM	10,000 CFM	12,000 CFM
Efficiency* Standard Power Supply	99%	95%	Not recommended	Not recommended	99%	95%	Not recommended	Not recommended	99%	95%	Not recommended	Not recommended
Efficiency* He Power Supply	99%	99%	95%	Not recommended	99%	99%	95%	Not recommended	99%	99%	95%	Not recommended
Efficiency* Double-Pass Precipitator Standard Power Supply	99%	99%	97%	93%	99%	99%	97%	93%	99%	99%	97%	93%
Power Input	120 VAC, 60 Hz, 1 Ph, 1.5 A 220-240 VAC, 50-60 Hz, 1 Ph, .75 A				120 VAC, 60 Hz, 1 Ph, 1.5 A 220-240 VAC, 50-60 Hz, 1 Ph, .75 A				120 VAC, 60 Hz, 1 Ph, 1.5 A 220-240 VAC, 50-60 Hz, 1 Ph, .75 A			
Number Of Cells	1				2				4			
Number Of Pre/Postfilters	1				2				4			

*Efficiencies based on testing to ASHRAE 52.2 standard

SMOKEMASTER® F72 Manually-Cleaned Electrostatic Precipitators

Model	SMOKEMASTER® F72A				SMOKEMASTER® F72B				SMOKEMASTER® F72C			
Primary Filter	Washable electrostatic								Washable electrostatic			
Airflow (Cfm)	1500 CFM	2000 CFM	2500 CFM	3000 CFM	3000 CFM	4000 CFM	5000 CFM	6000 CFM	6000 CFM	8000 CFM	10,000 CFM	12,000 CFM
Efficiency* Standard Power Supply	99%	95%	Not recommended	Not recommended	99%	95%	Not recommended	Not recommended	99%	95%	Not recommended	Not recommended
Efficiency* He Power Supply	99%	99%	95%	Not recommended	99%	99%	95%	Not recommended	99%	99%	95%	Not recommended
Efficiency* Double-Pass Precipitator Standard Power Supply	99%	99%	97%	93%	99%	99%	97%	93%	99%	99%	97%	93%
Power Input	120 VAC, 60 Hz, 1 Ph, 1.5 A 220-240 VAC, 50-60 Hz, 1 Ph, .75 A				120 VAC, 60 Hz, 1 Ph, 1.5 A 220-240 VAC, 50-60 Hz, 1 Ph, .75 A				120 VAC, 60 Hz, 1 Ph, 1.5 A 220-240 VAC, 50-60 Hz, 1 Ph, .75 A			
Number Of Cells	1				2				4			
Number Of Pre/Postfilters	1				2				4			

*Efficiencies based on testing to ASHRAE 52.2 standard

AUTOCLEAN® 2000

Air Volume (CFM)	1500 CFM	2000 CFM	2500 CFM	3000 CFM
Standard Power Supply single pass efficiency	99%	95%	Not Recommended	Not Recommended
HE Power Supply single pass efficiency	99%	99%	95%	Not Recommended
Efficiency* Double-Pass Precipitator Standard Power Supply	99%	99%	97%	93%
Pressure Drop (in.w.g.)	0.12	0.22	0.33	0.49
Dimension	32.50" W x 35.00" H x 21.00" L			
Duct Opening	21.67" W x 24.31" H			
Unit Weight	255 lbs. installed, 300 lbs. shipping			
Cabinet	14-16 gauge welded steel cabinet with a powder coat finish 100% Solid state			
Power Supply	Input: 120V, 50/60 Hz, 1 Phase or 240V, 50/60 Hz, 1 Phase			
HE = High Efficiency	Output: Ionizer 9,400 VDC / Collector 4,700 VDC			
Optional HE Power Supply	Output: Ionizer 12,000 VDC / Collector 4,500 VDC			
Ambient Temperature Rating	140° F maximum (outside of exhaust airflow)			
Electronic Cell Specification	Cell Dimensions: 24.25" L x 24.25" W x 10.75" D Collection Area: 240 square feet Voltage Gradient: 20,000 volts per inch Ionizer Wires: 11 wires per cell, 0.010 inch diameter, tungsten			
Number of Electronic Cells	1 Cell			
Number of Pre/Post Filters	1 Prefilter/1 Postfilter 24" L x 24" W x 1" D heavy-duty aluminum mesh			
Cell Cleaning Method	Programmable Self-Washing System			
Placement Preparation	Hot Water Supply Line: copper pipe 3/4" Waste Drain/Drip Pan Minimum clearance for cell removal: 28"			
After Filter (Optional) for Odor Control	Activated Carbon Module, which are refillable, black powder coated steel panels: 8 panels configured in v-shape. Activated carbon weight: 18 pounds per panel. Pressure drop: approximately 0.5" in.w.g. at 50 fpm.			
Unit Standard	ETL listed to: UL 867 Standard for Electrostatic Air Cleaners UL 710 Standard for Exhaust Hoods for Commercial Cooking Equipment			



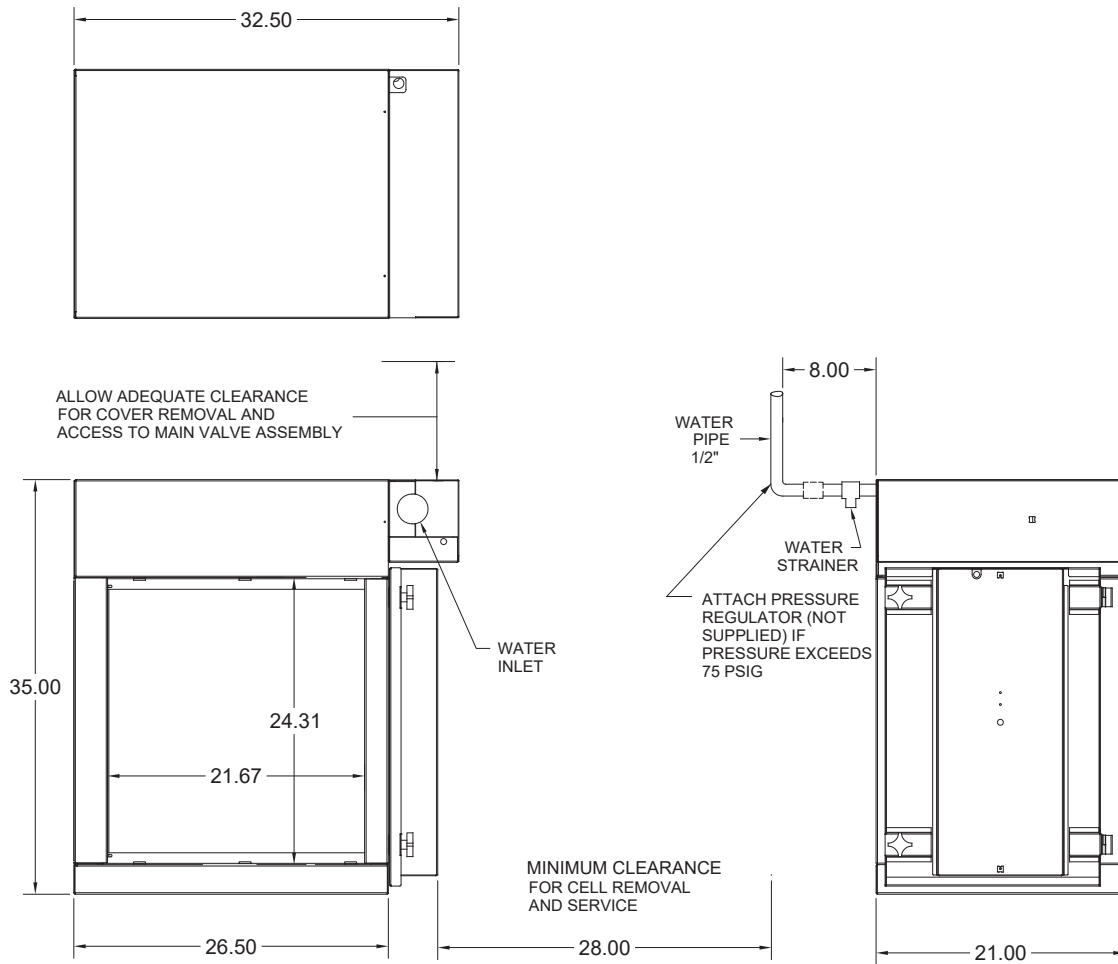

All dimensions nominal and in inches.



AUTOCLEAN® 4000

Air Volume (CFM)	3000 CFM	4000 CFM	5000 CFM	6000 CFM
Standard Power Supply single pass efficiency	99%	95%	Not Recommended	Not Recommended
HE Power Supply single pass efficiency	99%	99%	95%	Not Recommended
Efficiency* Double-Pass Precipitator Standard Power Supply	99%	99%	97%	93%
Pressure Drop (in.w.g.)	0.12	0.22	0.33	0.49
Dimension	56.25" W x 35.00" H x 21.00" L			
Duct Opening	45.44" W x 24.31" H			
Unit Weight	355 lbs. installed, 400 lbs. shipping			
Cabinet	14-16 gauge welded steel cabinet with a powder coat finish 100% solid state			
Power Supply	Input: 120V, 50/60 Hz, 1 Phase or 240V, 50/60 Hz, 1 Phase			
HE = High Efficiency	Output: Ionizer 9,400 VDC / Collector 4,700 VDC			
Optional HE Power Supply	Output: Ionizer 12,000 VDC / Collector 4,500 VDC			
Ambient Temperature Rating	140° F maximum (outside of exhaust airflow)			
Electronic Cell Specification	Cell Dimensions: 24.25" L x 24.25" W x 10.75" D Collection Area: 240 square feet Voltage Gradient: 20,000 volts per inch Ionizer Wires: 11 wires per cell, 0.010 inch diameter, tungsten			
Number of Electronic Cells	2 Cells			
Number of Pre/Post Filters	2 Prefilters/2 Postfilters 24" L x 24" W x 1" D heavy-duty aluminum mesh			
Cell Cleaning Method	Programmable Self-Washing System			
Placement Preparation	Hot Water Supply Line: copper pipe 3/4" Waste Drain/Drip Pan Minimum clearance for cell removal: 28"			
After Filter (Optional) for Odor Control	Activated Carbon Module, which are refillable, black powder coated steel panels: 16 panels configured in v-shape. Activated carbon weight: 18 pounds per panel. Pressure drop: approximately 0.5" in.w.g. at 50 fpm.			
Unit Standard	ETL listed to: UL 867 Standard for Electrostatic Air Cleaners UL 710 Standard for Exhaust Hoods for Commercial Cooking Equipment			



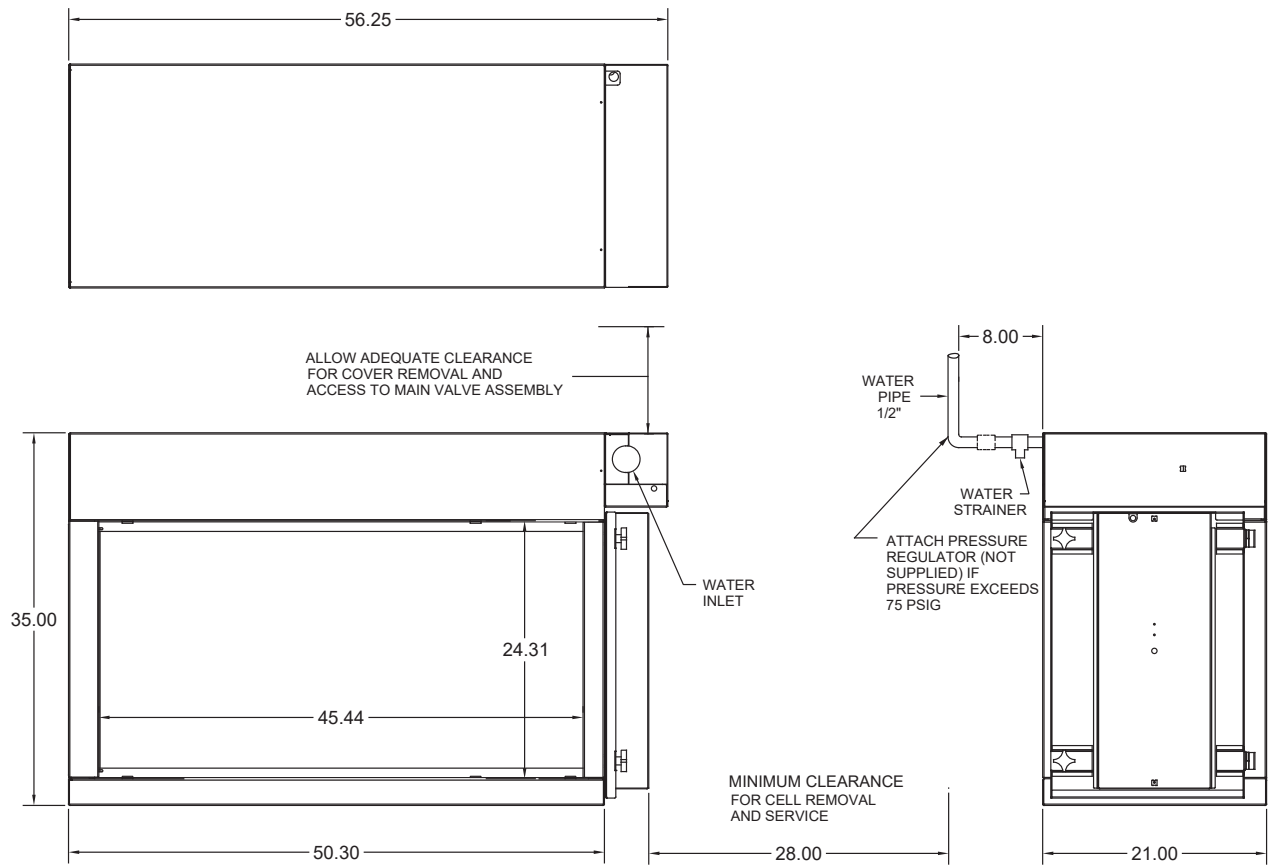

All dimensions nominal and in inches.



AUTOCLEAN® 8000

Air Volume (CFM)	6000 CFM	8000 CFM	10,000 CFM	12,000 CFM
Standard Power Supply single pass efficiency	99%	95%	Not Recommended	Not Recommended
HE Power Supply single pass efficiency	99%	99%	95%	Not Recommended
Efficiency* Double-Pass Precipitator Standard Power Supply	97%	99%	97%	93%
Pressure Drop (in.w.g.)	0.12	0.22	0.33	0.49
Dimension	56.25" W x 64.20" H x 21.00" L			
Duct Opening	45.44" W x 53.50" H			
Unit Weight	570 lbs. installed, 640 lbs. shipping			
Cabinet	14-16 gauge welded steel cabinet with a powder coat finish 100% solid state			
Power Supply	Input: 120V, 50/60 Hz, 1 Phase or 240V, 50/60 Hz, 1 Phase			
HE = High Efficiency	Output: Ionizer 9,400 VDC / Collector 4,700 VDC			
Optional HE Power Supply	Output: Ionizer 12,000 VDC / Collector 4,500 VDC			
Ambient Temperature Rating	140° F maximum (outside of exhaust airflow)			
Electronic Cell Specification	Cell Dimensions: 24.25" L x 24.25" W x 10.75" D Collection Area: 240 square feet Voltage Gradient: 20,000 volts per inch Ionizer Wires: 11 wires per cell, 0.010 inch diameter, tungsten			
Number of Electronic Cells	4 Cells			
Number of Pre/Post Filters	4 Prefilters/4 Postfilters 24" L x 24" W x 1" D heavy-duty aluminum mesh			
Cell Cleaning Method	Programmable Self-Washing System			
Placement Preparation	Hot Water Supply Line: copper pipe 1" Waste Drain/Drip Pan Minimum clearance for cell removal: 28"			
After Filter (Optional) for Odor Control	Activated Carbon Module, which are refillable, black powder coated steel panels: 32 panels configured in v-shape. Activated carbon weight: 18 pounds per panel. Pressure drop: approximately 0.5" in.w.g. at 50 fpm.			
Unit Standard	ETL listed to: UL 867 Standard for Electrostatic Air Cleaners UL 710 Standard for Exhaust Hoods for Commercial Cooking Equipment			



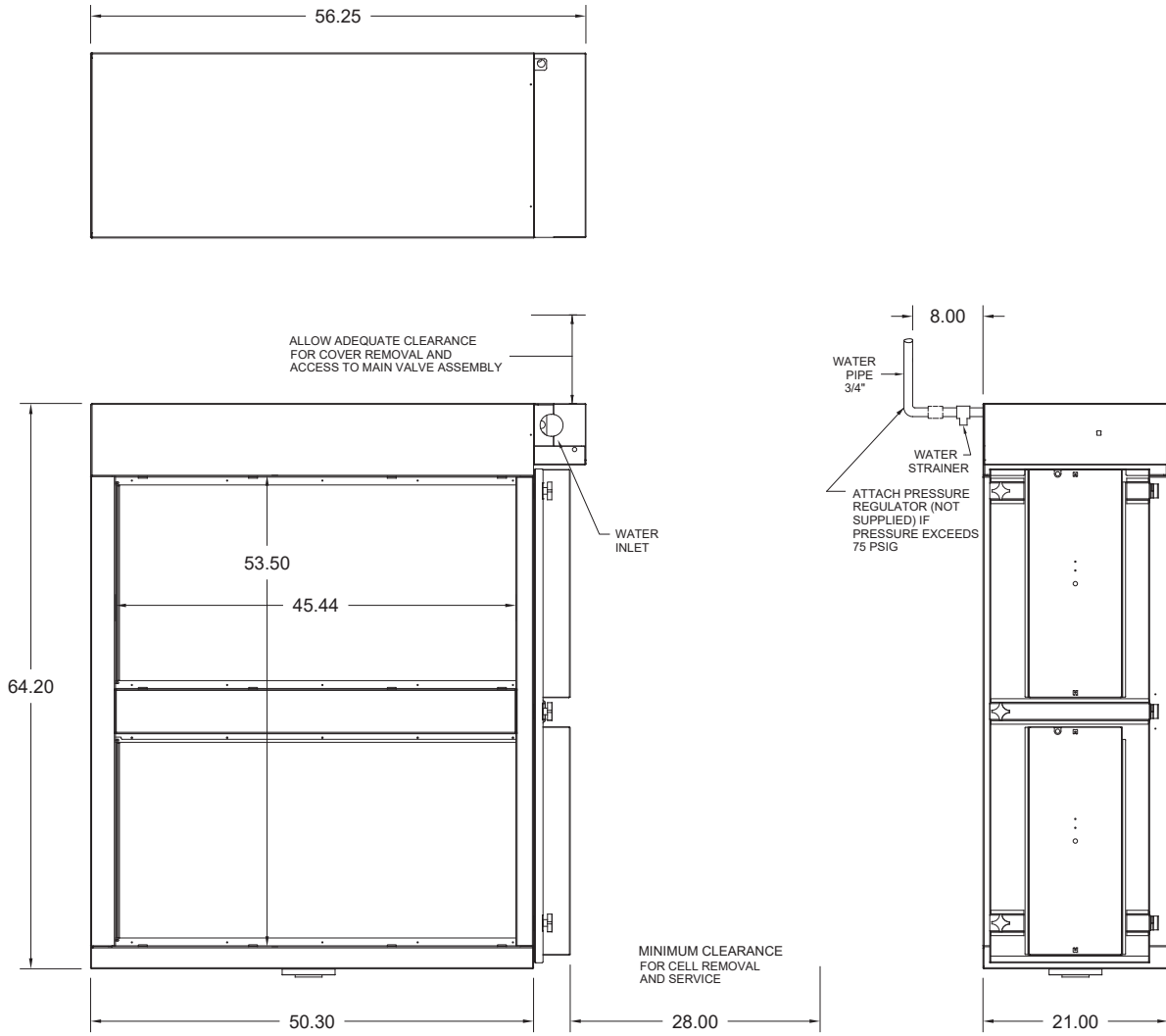

All dimensions nominal and in inches.



1.0 Electrostatic Air Cleaner

1.1 Equipment Description

- 1.1.1 The Air Cleaner shall be used to cleanse the contaminated air from commercial kitchen exhaust hoods containing grease, oil, smoke, fumes, odor, and dust particles.
- 1.1.2 The unit shall be modular in construction and shall have individual sections of prefilter, ionization collector section with automatic washing systems, and postfilter.
- 1.1.3 Optional additional passes of ionization collector sections with or without automatic washing systems; single and multiple passes of odor neutralizing section(s); utility or inline blowers; controls packages are all available.
- 1.1.4 All sections can be enclosed in an optional weather-resistant outdoor rated housing.

1.2 Equipment Specifications

- 1.2.1 The air cleaning system shall be an Air Quality Engineering, Inc. AUTOCLEAN® Model 2000, 4000, 8000 modular two stage Penny-type electrostatic precipitator.
- 1.2.2 Manufacturer shall supply the unit with expertise in design and manufacturing of products specified in this section with a minimum of 45 years of documented experience.
- 1.2.3 Unit shall comply with UL 867 and UL 710 standard or equivalent standards. The units shall be in complete accordance with ASHRAE standard 52.2 for air cleaners test and rating of efficiency, resistance and dust holding capacity.
 - 1.2.3.1 Ozone generation concentration shall not exceed 0.05 PPM.
- 1.2.4 Air cleaner shall be installed under the supervision of an Air Quality Engineering, Inc. employee or Air Quality Engineering, Inc. authorized and/or approved service technician.

1.3 Principle of Operation

- 1.3.1 The heavy duty pre-filter(s) and post-filter(s) (aluminum mesh) shall remove large particles, evenly distribute air across the cells, and contain the water and debris from the wash and rinse cycles.
- 1.3.2 The electronic filter shall remove the smaller grease, oil, smoke and dust particles.
- 1.3.3 The principle of operation shall be based on electrostatic precipitation.
- 1.3.4 The particle shall pass by an ionizing wire, which will induce a positive charge on the particle. The particle then shall pass between closely spaced aluminum plates (fins), which are held at a positive charge and a ground.
- 1.3.5 As the charged particle travels between the two aluminum plates it shall be forced away from the plate held at the identical polarity and drawn towards the grounded plate. Once attached the particle shall remain on the plate until cleaned off during washing.

1.4 Unit Housing

- 1.4.1 Housing shall be 16 gauge (1.5mm) and 14 gauge CRS with epoxy coat finish construction. All critical seams shall be welded.
- 1.4.2 Each section shall include single door access, located on one side of the unit. The access door shall be mounted on metal hinges and secured with gasket sealed knob style latches allowing for component access and removal. All doors shall be gasketed to prevent air and water leakage.
- 1.4.3 High voltage contacts on the housing shall be made of stainless steel.
- 1.4.4 High voltage supply is to be located in the door.
- 1.4.5 All drainage piping shall be metal.
- 1.4.6 The contractor should install a drain trap to serve as a vacuum break.
- 1.4.7 Between each section should be sealed with a permanent seal.
- 1.4.8 Each unit shall have track guides for proper alignment of cell, making it possible to change the direction of airflow by reversing the orientation of electronic collector cell(s).

1.5 Finish

1.5.1 The external casing finish shall be a durable industrial grade semi gloss baked on epoxy ester, not less than 3-mil minimum thickness.

1.6 Prefilter and Postfilter

1.6.1 Access to the heavy duty pre-filter and post-filter shall be from the side through the same hinged door used to gain access to the electronic cells.

1.6.2 Separator section shall be designed for an equal airflow across the entire air-cleaning unit.

1.6.3 All liquid and solid particulate removable by the separator shall be collected and drained from the collector system during operation and during the wash cycle.

1.6.4 Frame
Washable aluminum.

1.6.5 Media
Washable aluminum 1.00 inch thick mesh layered to optimally remove larger particles of grease and dust before the main filter. Face of each prefilter shall be 4 square feet (1.47 square meters).

1.7 Electronic Cells

Electronic cells described in this section refer to a full size cell. Half size cells also can be specified.

1.7.1 Ionizing-collecting cells shall be of one-piece construction 10.75 inches (273 mm) deep in direction of airflow. Face area of each cell shall be 4.08 square feet (0.38 square meters) and the effective collecting area 240 square feet (22.29 square meters).

1.7.2 Frame
All support framing, end plates and ionizer ground electrodes shall be 0.080-inch (2.03-mm) thick aluminum.

1.7.3 Handle shall be located on the side of the cell for removal of the cell from the air cleaner. The handle shall be grounded to the frame of the cell. Engraving shall be on the handle indicating "this side out".

1.7.4 Contacts shall be made of stainless steel on the front of the cell. They shall make contact with the ionizing, collector and ground sections of the cell.

1.7.5 Ionizer Section

1.7.5.1 Ionizing wires shall be minimum of 11 per electronic cell, with a length of 20.32 inches (533.4 mm) each.

1.7.5.2 Ionizing wires shall be constructed of 0.010 inches diameter (0.25 mm) tungsten for prevention of corroding or breaking. Wires shall be fixed at one end and spring mounted on the other for ease of maintenance.

1.7.5.3 There shall be 10 grounding plates between the wires to stabilize the ionization field for better performance. Grounding plates shall be no greater than 1.964 inches (49.89 mm) apart, and 0.063 inches (1.6 mm) thick.

1.7.5.4 Insulators for the ionizer shall be made of ceramic measuring 1.0 inches (25.4 mm) thick by 2.25 inches (57.15 mm) square with a center hole measuring 0.275 inches (6.95 mm) in diameter. The insulators should have a protective coating of glazing to retard tracking. Insulators shall not number less than 4 in the ionizer section.

1.7.6 Collector Section

- 1.7.6.1 Grounding plates shall be a minimum of 0.025 inches (0.635 mm) thick aluminum. The plates shall be 7.64 inches (194 mm) deep in the direction of airflow. Grounding plates shall be a minimum of 54 quantity per cell. Spacing between grounding plates shall be at 0.3678 inches (9.34 mm). Spacing between the grounding plates and the charged plates shall be at 0.1839 inches (4.67 mm).
 - 1.7.6.2 Charged plates shall be a minimum of 0.025 inches (0.635 mm) thick aluminum. The plates shall be 7.14 inches (181.36 mm) deep in the direction of airflow. Charged plates shall be a minimum of 55 quantity per cell. Spacing between charged plates shall be at 0.3678 inches (9.34 mm).
 - 1.7.6.3 Spacers shall be made of aluminum to hold the ground and charged plates apart at given lengths. Rods shall be 0.25 inches (6.35 mm) in diameter. The spacers shall run the length of the cell to the frame of the cell. There shall be at least 11 rods total per cell.
 - 1.7.6.4 Insulators for the collector shall be made of ceramic measuring 0.8 inches (20.32 mm) thick by 2.25 inches (57.15 mm) square with a center hole measuring 0.275 inches (6.99 mm) in diameter. The insulators should have a protective coating of glazing to retard tracking. Insulators shall not number less than 10. Insulator shall be out of the air stream.
- 1.7.7 Markings shall be on the cell to inform clean weight of the cell. Engraving shall be on the cell indicating direction of the airflow.

1.8 Power Supply

- 1.8.1 Power supply shall be of a 100% solid state type.
- 1.8.2 Power supply shall be mounted within the air cleaner, out of the air stream and wash components.
- 1.8.3 Voltages
 - 1.8.3.1 Input voltage shall be 108-132 VAC, 60 HZ, 1 phase or 216-264 VAC, 50/60 HZ, 1 phase.
 - 1.8.3.2 Output High frequency with built in short circuit and arc protection, providing a dual high voltage output of (+)9.5 KVDC for the ionizer and (+)4.7 KVDC for the collector.
- 1.8.4 Optional HE power supply available to boost ionizer voltage to (+)12 KVDC to increase efficiency.
- 1.8.5 The power supply shall operate over a temperature range of -20 to 140 degrees F (-38 to 85 degrees C).
- 1.8.6 Be self-protecting.
- 1.8.7 Accommodate a neon light indicating the performance status.

1.9 Interlock Switches

- 1.9.1 Location – Integrally grounded, door operated electrical safety interlock switch shall be provided to prevent access to the high voltage collector cells without first interrupting the primary input power.

1.10 Wash System

- 1.10.1 Detergent Pump
 - 1.10.1.1 Detergent used shall be Air Quality Engineering, Inc.'s Electronic Cell Cleaner Concentrate or approved equal.
 - 1.10.1.2 Pump shall move 0.042 GPM (9.54 liters per hour) of detergent, and have a vertical rise rating of 7 feet (2.13 meters).
 - 1.10.1.3 Air Quality Engineering, Inc.'s Electronic Cell Cleaner Concentrate shall not be diluted before being introduced to the AUTOCLEAN® detergent pump.
- 1.10.2 Water Valve
 - 1.10.2.1 Water wash temperature shall be 125 to 160 degrees F (51 to 71 degrees C).
 - 1.10.2.2 Shall use between 28-35 gallons of water per wash cycle per cell user adjustable.

- 1.10.3 Manifold Motor and Gears
 - 1.10.3.1 Manifold motor shall be located within the unit out of the air stream.
 - 1.10.3.2 Manifold motor for spray assembly shall have a minimum of 4 RPM.
 - 1.10.3.3 Gears shall be constructed of heat treated steel.
 - 1.10.3.4 Manifold motor housing shall be made of cast aluminum.
 - 1.10.3.5 Manifold motor shall have a life expectancy of 20 years operated at normal conditions.
- 1.10.4 Detergent Valve
 - 1.10.4.1 Detergent usage shall be approximately 5-7 ounces per cell per wash, user adjustable.
- 1.10.5 Piping
 - 1.10.5.1 All piping shall be NPT.
 - 1.10.5.2 Nozzles
 - 1.10.5.2.1 Spray bar assembly in its entirety shall achieve 100% coverage of the collector cell. Assembly shall be located for overhead component cleaning.
 - 1.10.5.2.2 Water wash spray shall articulate over a 73-degree range of motion.
 - 1.10.5.2.3 Spray bar shall traverse along the cell with a minimum of 1.5 inches (3.81 cm) of travel.
 - 1.10.5.2.4 There shall be a minimum of 7 nozzles per cell spaced no more than 4 inches (10.16 cm) and no less than 3 inches (7.62 cm) apart.
 - 1.10.5.2.5 Pressure of spray on the cells shall be no greater than 75 psi (517 KPa).
 - 1.10.5.2.6 Nozzles shall not use a conical or cone type spray pattern design.
 - 1.10.5.3 Piping installed to solenoid valve shall be brass and solderless for easier service and replacement.
- 1.10.6 Solenoid valve shall be fail-closed to prevent excessive leaking in the event of failure.
- 1.11 Programmable Logic Controller (PLC)**
 - 1.11.1 Shall be housed inside of the AUTOCLEAN®, out of the air stream.
 - 1.11.2 Shall have a touch screen display for adjusting the wash sequence.
 - 1.11.3 Shall have dry contacts to control fan, high voltage power supply, detergent pump, and water valve with manifold motor.
 - 1.11.4 PLC Inputs
 - 1.11.4.1 Heat sensor input that can be wired to a heat sensor install in the kitchen that can trigger the system to turn on the fan and EAC.
 - 1.11.4.2 BMS wash input to control the wash from a Building Management System.
 - 1.11.4.3 Detergent tank sensor to show low detergent on the PLC and HMI screen.
 - 1.11.4.4 ANSUL control that allows the ANSUL system to turn the fan on and EAC off during any phase the AUTOCLEAN is in.
 - 1.11.5 Operator shall have the ability to field adjust the length of time individually for the fan shut down cycle, detergent pump cycle, rinse cycle, fan dry cycle, and cumulatively for the overall wash cycle time.
 - 1.11.6 Operator shall have the ability to program when the wash sequence will execute for each day of the week.
 - 1.11.7 Shall automatically open and close solenoid valves, activate relay to shut down fan, and reduce flow during detergent spray and soak.
 - 1.11.8 Manual wash initiation can be manually started through the touch screen.
 - 1.11.9 When initiated, will sequence through a 5-step process including fan shut down, detergent soak, rinse, fan dry with precipitator off and system return to operation.
 - 1.11.10 Two independent advance menu options available to have the fan "on" or "off" during drying and system can go into sleep mode after the wash cycle.
 - 1.11.11 Optional HMI screen available to allow remote installation and control of unit PLC. HMI is connected by Ethernet to a maximum of 8 units.
- 1.12 1 Year Limited Parts Warranty is Included.**

2.0 Odor Neutralizer

2.1 Equipment Description

- 2.1.1 The Odor Neutralizer shall be used to cleanse the contaminated air from kitchen exhaust hoods containing gases and vapors (odors).
- 2.1.2 The unit shall be modular in construction and shall go inline with an Air Quality Engineering, Inc. AUTOCLEAN® 2000, 4000 or 8000 Model Air Cleaner.

2.2 Equipment Specifications

- 2.2.1 The Odor Neutralizer shall be an Air Quality Engineering, Inc. Carbon Module.
- 2.2.2 Manufacturer shall supply the unit with expertise in design and manufacturing of products specified in this section.
- 2.2.3 Odor Neutralizer shall be installed under the supervision of an Air Quality Engineering, Inc. employee or Air Quality Engineering, Inc. authorized and/or approved service technician.

2.3 Principle of Operation

- 2.3.1 The principle of operation shall be based on adsorption in the airstream. Adsorption is the process where a gas is taken to a porous substance and held there.
- 2.3.2 Activated Carbon is used only to adsorb materials that are in the gaseous or vaporized state. Materials that cannot be removed by particulate filters.
- 2.3.3 Gases and vapors travel through the carbon filter and are adsorbed into the micropore structure of the carbon.

2.4 Carbon Media

- 2.4.1 Carbon
 - 2.4.1.1 Base material shall be of Virgin Coconut Shell allowing for high affinity.
 - 2.4.1.2 Particle size shall be 4 x 8 allowing for a range of adsorbent retention.
 - 2.4.1.3 Carbon tetrachloride activity shall initially be at 60 minimum.
 - 2.4.1.4 Hardness number shall be 97 minimum.
 - 2.4.1.5 Density shall be an average of 31 pounds per cubic foot (497 kg per cubic meter).
 - 2.4.1.6 Total ash content shall not exceed 2%.
 - 2.4.1.7 Iodine number shall be greater than 1050.
- 2.4.2 Panels
 - 2.4.2.1 Panels shall be of a V-bank configuration.
 - 2.4.2.2 Panels shall be 26 gauge (.45 mm) galvanized steel.
 - 2.4.2.3 Panels shall hold a minimum of 18 pounds (8.18 kg) carbon each. Panels shall measure approx. 23.625 inches (60 cm) by approx. 23.625 inches (60 cm). Panels shall be approx. 2-inch (5.08-cm) thick minimum.
 - 2.4.2.4 Airflow shall not exceed a face velocity of 65 ft per minute (19.8 meters per minute).
 - 2.4.2.5 Panels shall be bulk refillable.

2.5 Safety Filter(s)

- 2.5.1 MERV 14 (ASHRAE Standard 52.2-1999)
- 2.5.2 Nominal 24" x 24" x 4"
- 2.5.3 Gradient Density Microfiberglass Media
- 2.5.4 Frame: 24 gauge Aluminized Steel
- 2.5.5 Media Separators: Corrugated Aluminum with hemmed safety edge
- 2.5.6 Faceguard on Upstream and Downstream Side of Filter

SMOKEMASTER® F72A

Air Volume (CFM)	1500 CFM	2000 CFM	2500 CFM	3000 CFM
Standard Power Supply single pass efficiency	99%	95%	Not Recommended	Not Recommended
HE Power Supply single pass efficiency	99%	99%	95%	Not Recommended
Efficiency* Double-Pass Precipitator Standard Power Supply	99%	99%	97%	93%
Pressure Drop (in.w.g.)	0.12	0.22	0.33	0.49
Dimension	32.50" W x 35.00" H x 21.00" L			
Duct Opening	21.67" W x 24.31" H			
Unit Weight	235 lbs. installed, 280 lbs. shipping			
Cabinet	14-16 gauge welded steel cabinet with a powder coat finish 100% solid state			
Power Supply	Input: 120V, 50/60 Hz, 1 Phase or 240V, 50/60 Hz, 1 Phase			
HE = High Efficiency	Output: Ionizer 9,400 VDC / Collector 4,700 VDC			
Optional HE Power Supply	Output: Ionizer 12,000 VDC / Collector 4,500 VDC			
Ambient Temperature Rating	140° F maximum (outside of exhaust airflow)			
Electronic Cell Specification	Cell Dimensions: 24.25" L x 24.25" W x 10.75" D Collection Area: 240 square feet Voltage Gradient: 20,000 volts per inch Ionizer Wires: 11 wires per cell, 0.010 inch diameter, tungsten Weight: 60 lbs. Per cell.			
Number of Electronic Cells	1 Cell			
Cell Cleaning Method	Manual Wash			
Placement Preparation	Minimum clearance for cell removal: 28"			
Pre/Post Filters	1" thick			
After Filter (Optional) for Odor Control	Activated Carbon Module, which are refillable, black powder coated steel panels: 8 panels configured in v-shape. Activated carbon weight: 18 pounds per panel. Pressure drop: approximately 0.5" in.w.g. at 50 fpm.			
Unit Standard	ETL listed to: UL 867 Standard for Electrostatic Air Cleaners UL 710 Standard for Exhaust Hoods for Commercial Cooking Equipment			



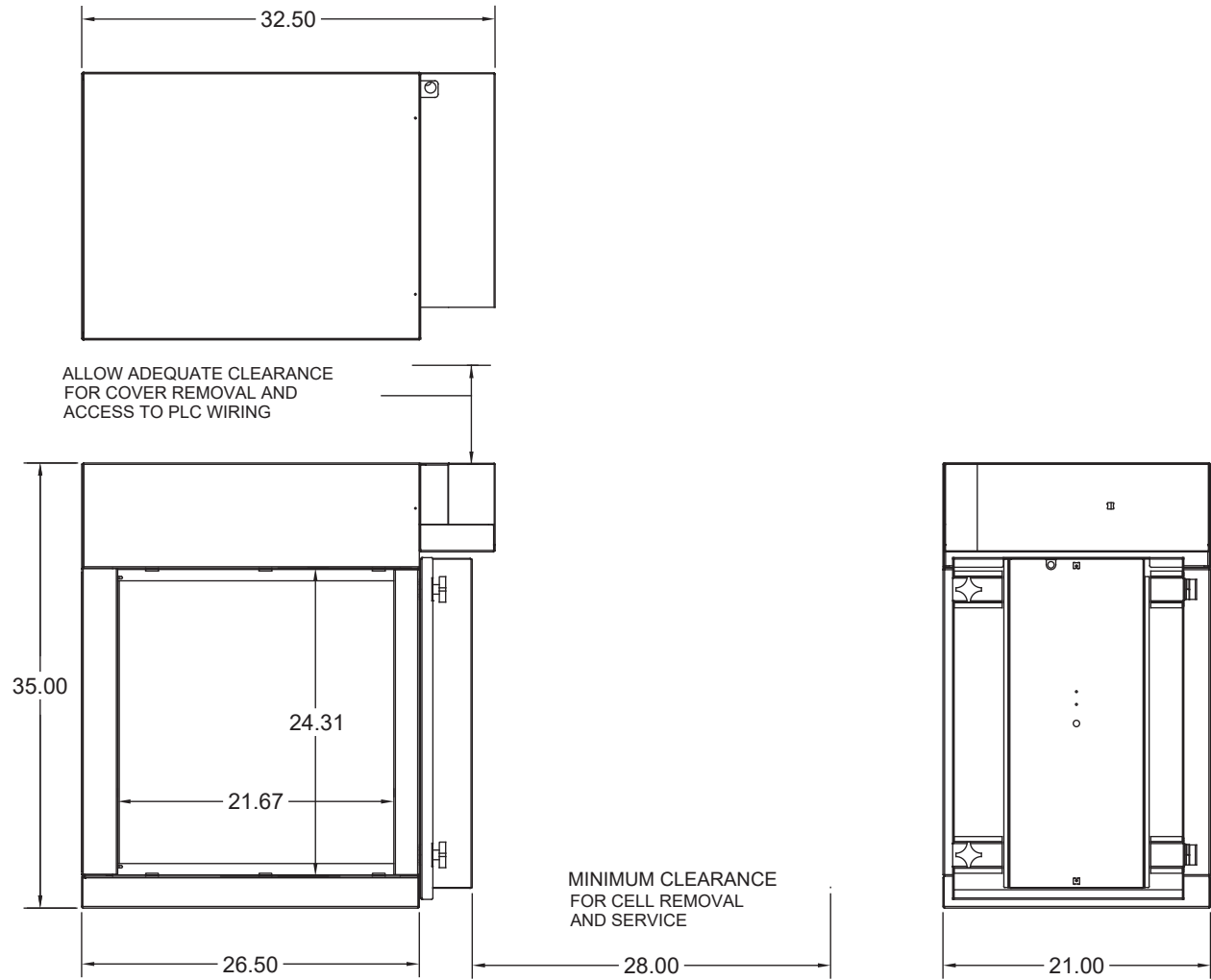

All dimensions nominal and in inches.



SMOKEMASTER® F72B

Air Volume (CFM)	3000 CFM	4000 CFM	5000 CFM	6000 CFM
Standard Power Supply single pass efficiency	99%	95%	Not Recommended	Not Recommended
HE Power Supply single pass efficiency	99%	99%	95%	Not Recommended
Efficiency* Double-Pass Precipitator Standard Power Supply	99%	99%	97%	93%
Pressure Drop (in.w.g.)	0.12	0.22	0.33	0.49
Dimension	56.25" W x 35.00" H x 21.00" L			
Duct Opening	45.44" W x 24.31" H			
Unit Weight	315 lbs. installed, 350 lbs. shipping			
Cabinet	14-16 gauge welded steel cabinet with a powder coat finish 100% solid state			
Power Supply	Input: 120V, 50/60 Hz, 1 Phase or 240V, 50/60 Hz, 1 Phase			
HE = High Efficiency	Output: Ionizer 9,400 VDC / Collector 4,700 VDC			
Optional HE Power Supply	Output: Ionizer 12,000 VDC / Collector 4,500 VDC			
Ambient Temperature Rating	140° F maximum (outside of exhaust airflow)			
Electronic Cell Specification	Cell Dimensions: 24.25" L x 24.25" W x 10.75" D Collection Area: 240 square feet Voltage Gradient: 20,000 volts per inch Ionizer Wires: 11 wires per cell, 0.010 inch diameter, tungsten Weight: 60 lbs. per cell			
Number of Electronic Cells	2 Cells			
Cell Cleaning Method	Manual Wash			
Placement Preparation	Minimum clearance for cell removal: 28"			
Pre/Post Filters	1" thick			
After Filter (Optional) for Odor Control	Activated Carbon Module, which are refillable, black powder coated steel panels: 16 panels configured in v-shape. Activated carbon weight: 18 pounds per panel. Pressure drop: approximately 0.5" in.w.g. at 50 fpm.			
Unit Standard	ETL listed to: UL 867 Standard for Electrostatic Air Cleaners UL 710 Standard for Exhaust Hoods for Commercial Cooking Equipment			



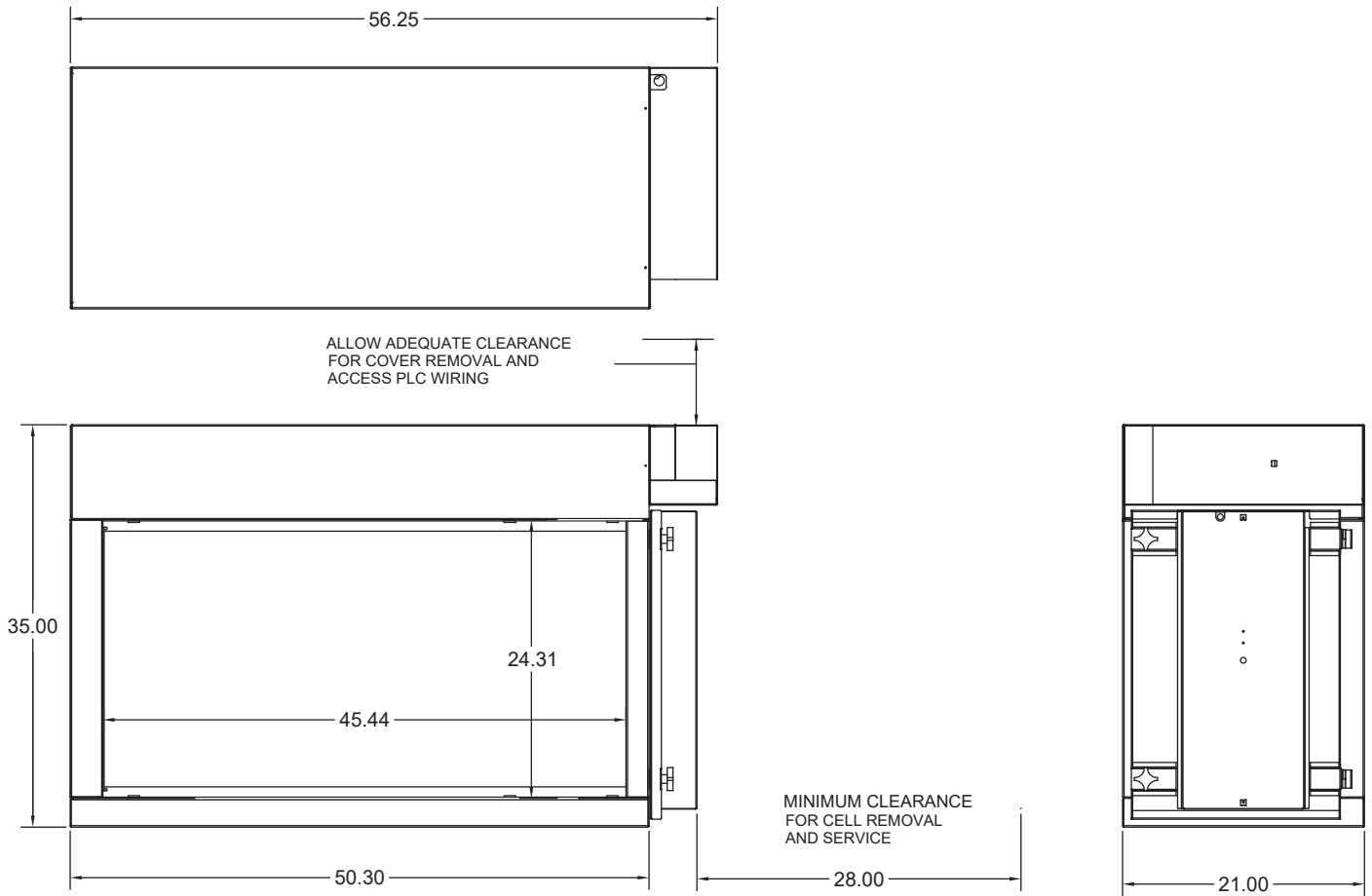

All dimensions nominal and in inches.



SMOKEMASTER® F72C

Air Volume (CFM)	6000 CFM	8000 CFM	10,000 CFM	12,000 CFM
Standard Power Supply single pass efficiency	99%	95%	Not Recommended	Not Recommended
HE Power Supply single pass efficiency	99%	99%	95%	Not Recommended
Efficiency* Double-Pass Precipitator Standard Power Supply	97%	99%	97%	93%
Pressure Drop (in.w.g.)	0.12	0.22	0.33	0.49
Dimension	56.25" W x 64.20" H x 21.00" L			
Duct Opening	45.44" W x 53.50" H			
Unit Weight	545 lbs. installed, 615 lbs. shipping			
Cabinet	14-16 gauge welded steel cabinet with a powder coat finish 100% solid state			
Power Supply	Input: 120V, 50/60 Hz, 1 Phase or 240V, 50/60 Hz, 1 Phase			
HE = High Efficiency	Output: Ionizer 9,400 VDC / Collector 4,700 VDC			
Optional HE Power Supply	Output: Ionizer 12,000 VDC / Collector 4,500 VDC			
Ambient Temperature Rating	140° F maximum (outside of exhaust airflow)			
Electronic Cell Specification	Cell Dimensions: 24.25" L x 24.25" W x 10.75" D Collection Area: 240 square feet Voltage Gradient: 20,000 volts per inch Ionizer Wires: 11 wires per cell, 0.010 inch diameter, tungsten Weight: 60 lbs. per cell			
Number of Electronic Cells	4 Cells			
Cell Cleaning Method	Manual Wash			
Placement Preparation	Minimum clearance for cell removal: 28"			
Pre/Post Filters	1" thick			
After Filter (Optional) for Odor Control	Activated Carbon Module, which are refillable, black powder coated steel panels: 32 panels configured in v-shape. Activated carbon weight: 18 pounds per panel. Pressure drop: approximately 0.5" in.w.g. at 50 fpm.			
Unit Standard	ETL listed to: UL 867 Standard for Electrostatic Air Cleaners UL 710 Standard for Exhaust Hoods for Commercial Cooking Equipment			



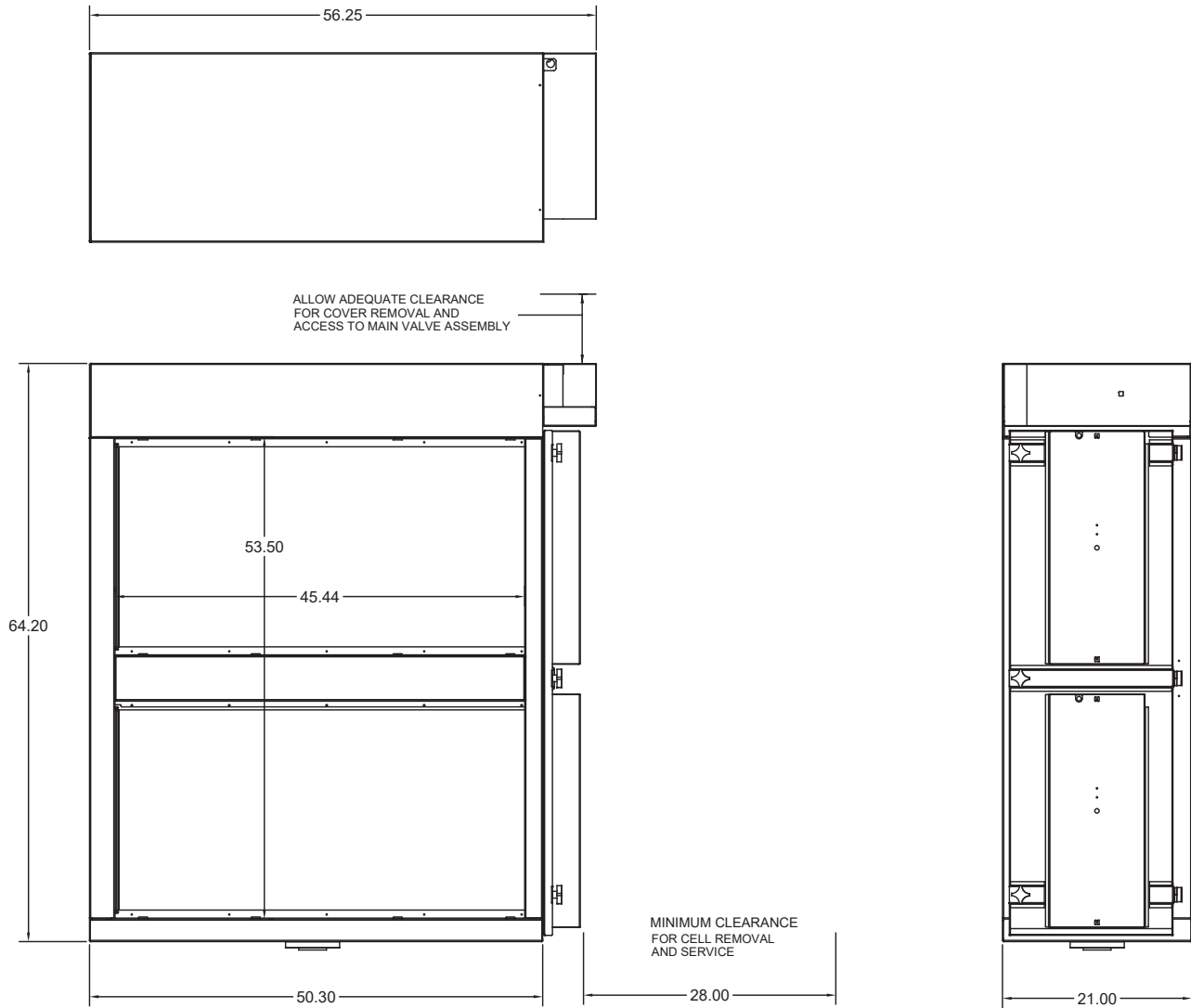

All dimensions nominal and in inches.



1.0 Electrostatic Air Cleaner

1.1 Equipment Description

- 1.1.1 The Air Cleaner shall be used to cleanse the contaminated air from commercial kitchen exhaust hoods containing grease, oil, smoke, fumes, odor, and dust particles.
- 1.1.2 The unit shall be modular in construction and shall have individual sections of prefilter, ionization collector section, and postfilter.
- 1.1.3 Optional additional passes of ionization collector sections with or without automatic washing systems; single and multiple passes of odor neutralizing section(s); utility or inline blowers; controls packages are all available.
- 1.1.4 All sections can be enclosed in an optional weather-resistant outdoor rated housing.

1.2 Equipment Specifications

- 1.2.1 The air cleaning system shall be an Air Quality Engineering, Inc. Model SMOKEMASTER® F72A, SMOKEMASTER® F72B, and/or SMOKEMASTER® F72C modular two stage Penny-type electrostatic precipitator.
- 1.2.2 Manufacturer shall supply the unit with expertise in design and manufacturing of products specified in this section with a minimum of 45 years of documented experience.
- 1.2.3 Unit shall comply with UL 867 and UL 710 standard or equivalent standards. The units shall be in complete accordance with ASHRAE standard 52.2 for air cleaners test and rating of efficiency, resistance and dust holding capacity.
 - 1.2.3.1 Ozone generation concentration shall not exceed 0.05 PPM.
- 1.2.4 Air cleaner shall be installed under the supervision of an Air Quality Engineering, Inc. employee or Air Quality Engineering, Inc. authorized and/or approved service technician.

1.3 Principle of Operation

- 1.3.1 The heavy duty pre-filter(s) and post-filter(s) (aluminum mesh) shall remove large particles, and evenly distribute air across the cells.
- 1.3.2 The electronic filter shall remove the smaller grease, oil, smoke and dust particles.
- 1.3.3 The principle of operation shall be based on electrostatic precipitation.
- 1.3.4 The particle shall pass by an ionizing wire, which will induce a positive charge on the particle. The particle then shall pass between closely spaced aluminum plates (fins), which are held at a positive charge and a ground.
- 1.3.5 As the charged particle travels between the two aluminum plates it shall be forced away from the plate held at the identical polarity and drawn towards the grounded plate. Once attached the particle shall remain on the plate until cleaned off during washing.

1.4 Unit Housing

- 1.4.1 Housing shall be 16 gauge (1.5mm) and 14 gauge CRS with epoxy coat finish construction. All critical seams shall be welded.
- 1.4.2 Each section shall include single door access, located on one side of the unit. The access door shall be mounted on metal hinges and secured with gasket sealed knob style latches allowing for component access and removal. All doors shall be gasketed to prevent air and water leakage.
- 1.4.3 High voltage contacts on the housing shall be made of stainless steel.
- 1.4.4 High voltage supply is to be located in the door.
- 1.4.5 All drainage piping shall be metal.
- 1.4.6 The contractor should install a drain trap to serve as a vacuum break.
- 1.4.7 Between each section should be sealed with a permanent seal.
- 1.4.8 Each unit shall have track guides for proper alignment of cell, making it possible to change the direction of airflow by reversing the orientation of electronic collector cell(s).

1.5 Finish

1.5.1 The external casing finish shall be a durable industrial grade semi-gloss baked on epoxy ester, not less than 3-mil minimum thickness.

1.6 Prefilter and Postfilter

- 1.6.1 Access to the heavy duty pre-filter and post-filter shall be from the side through the same hinged door used to gain access to the electronic cells.
- 1.6.2 Separator section shall be designed for an equal airflow across the entire air-cleaning unit.
- 1.6.3 All liquid and solid particulate removable by the separator shall be collected and drained from the collector system during operation.
- 1.6.4 Frame
Washable aluminum.
- 1.6.5 Media
Washable aluminum 1.00 inch thick mesh layered to optimally remove larger particles of grease and dust before the main filter. Face of each prefilter shall be 4 square feet (1.47 square meters).

1.7 Electronic Cells

Electronic cells described in this section refer to a full size cell. Half size cells also can be specified.

- 1.7.1 Ionizing-collecting cells shall be of one-piece construction 10.75 inches (273 mm) deep in direction of airflow. Face area of each cell shall be 4.08 square feet (0.38 square meters) and the effective collecting area 240 square feet (22.29 square meters).
- 1.7.2 Frame
All support framing, end plates and ionizer ground electrodes shall be 0.080-inch (2.03-mm) thick aluminum.
- 1.7.3 Handle shall be located on the side of the cell for removal of the cell from the air cleaner. The handle shall be grounded to the frame of the cell. Engraving shall be on the handle indicating "this side out".
- 1.7.4 Contacts shall be made of stainless steel on the front of the cell. They shall make contact with the ionizing, collector and ground sections of the cell.
- 1.7.5 Ionizer Section
- 1.7.5.1 Ionizing wires shall be a minimum of 11 per electronic cell, with a length of 20.32 inches (533.4 mm) each.
- 1.7.5.2 Ionizing wires shall be constructed of 0.010 inches diameter (0.25 mm) tungsten for prevention of corroding or breaking. Wires shall be fixed at one end and spring mounted on the other for ease of maintenance.
- 1.7.5.3 There shall be 10 grounding plates between the wires to stabilize the ionization field for better performance. Grounding plates shall be no greater than 1.964 inches (49.89 mm) apart, and 0.063 inches (1.6 mm) thick.
- 1.7.5.4 Insulators for the ionizer shall be made of ceramic measuring 1.0 inches (25.4 mm) thick by 2.25 inches (57.15 mm) square with a center hole measuring 0.275 inches (6.95 mm) in diameter. The insulators should have a protective coating of glazing to retard tracking. Insulators shall not number less than 4 in the ionizer section.

1.7.6 Collector Section

- 1.7.6.1 Grounding plates shall be a minimum of 0.025 inches (0.635 mm) thick aluminum. The plates shall be 7.64 inches (194 mm) deep in the direction of airflow. Grounding plates shall be a minimum of 54 quantity per cell. Spacing between grounding plates shall be at 0.3678 inches (9.34 mm). Spacing between the grounding plates and the charged plates shall be at 0.1839 inches (4.67 mm).
- 1.7.6.2 Charged plates shall be a minimum of 0.025 inches (0.635 mm) thick aluminum. The plates shall be 7.14 inches (181.36 mm) deep in the direction of airflow. Charged plates shall be a minimum of 55 quantity per cell. Spacing between charged plates shall be at 0.3678 inches (9.34 mm).
- 1.7.6.3 Spacers shall be made of aluminum to hold the ground and charged plates apart at given lengths. Rods shall be 0.25 inches (6.35 mm) in diameter. The spacers shall run the length of the cell to the frame of the cell. There shall be at least 11 rods total per cell.
- 1.7.6.4 Insulators for the collector shall be made of ceramic measuring 0.8 inches (20.32 mm) thick by 2.25 inches (57.15 mm) square with a center hole measuring 0.275 inches (6.99 mm) in diameter. The insulators should have a protective coating of glazing to retard tracking. Insulators shall not number less than 10. Insulator shall be out of the air stream.

- 1.7.7 Markings shall be on the cell to inform clean weight of the cell. Engraving shall be on the cell indicating direction of the airflow.

1.8 Power Supply

- 1.8.1 Power supply shall be of a 100% solid state type.
- 1.8.2 Power supply shall be mounted within the air cleaner, out of the air stream and wash components.
- 1.8.3 Voltages
 - 1.8.3.1 Input voltage shall be 108-132 VAC, 60 HZ, 1 phase or 216-264 VAC, 50/60 HZ, 1 phase.
 - 1.8.3.2 Output High frequency with built in short circuit and arc protection, providing a dual high voltage output of (+)9.5 KVDC for the ionizer and (+)4.7 KVDC for the collector.
- 1.8.4 Optional HE power supply available to boost ionizer voltage to (+)12 KVDC to increase efficiency.
- 1.8.5 The power supply shall operate over a temperature range of -20 to 140 degrees F (-38 to 85 degrees C).
- 1.8.6 Be self-protecting.
- 1.8.7 Accommodate a neon light indicating the performance status.

1.9 Interlock Switches

- 1.9.1 Location – Integrally grounded, door operated electrical safety interlock switch shall be provided to prevent access to the high voltage collector cells without first interrupting the primary input power.

1.10 OPTIONAL Programmable Logic Controller (PLC)

- 1.10.1 Shall be housed inside of the SMOKEMASTER® F72, out of the air stream.
- 1.10.2 Shall have a touch screen display.
- 1.10.3 Shall have dry contacts to control fan and high voltage power supply
- 1.10.4 PLC Inputs
 - 1.10.4.1 Heat sensor input that can be wired to a heat sensor install in the kitchen that can trigger the system to turn on the fan and EAC.
 - 1.10.4.2 ANSUL control that allows the ANSUL system to turn the fan on and EAC off during any phase the SMOKEMASTER® F72 is in.
- 1.10.5 Optional HMI screen available to allow remote installation and control of unit PLC. HMI is connected by Ethernet to a maximum of 8 units.

1.11 1 Year Limited Parts Warranty is Included.

2.0 Odor Neutralizer

2.1 Equipment Description

- 2.1.1 The Odor Neutralizer shall be used to cleanse the contaminated air from kitchen exhaust hoods containing gases and vapors (odors).
- 2.1.2 The unit shall be modular in construction and shall go inline with an Air Quality Engineering, Inc. SMOKEMASTER® F72A, SMOKEMASTER® F72B, and/or SMOKEMASTER® F72C Model Air Cleaner.

2.2 Equipment Specifications

- 2.2.1 The Odor Neutralizer shall be an Air Quality Engineering, Inc. Carbon Module.
- 2.2.2 Manufacturer shall supply the unit with expertise in design and manufacturing of products specified in this section.
- 2.2.3 Odor Neutralizer shall be installed under the supervision of an Air Quality Engineering, Inc. employee or Air Quality Engineering, Inc. authorized and/or approved service technician.

2.3 Principle of Operation

- 2.3.1 The principle of operation shall be based on adsorption in the airstream. Adsorption is the process where a gas is taken to a porous substance and held there.
- 2.3.2 Activated Carbon is used only to adsorb materials that are in the gaseous or vaporized state. Materials that cannot be removed by particulate filters.
- 2.3.3 Gases and vapors travel through the carbon filter and are adsorbed into the micropore structure of the carbon.

2.4 Carbon Media

- 2.4.1 Carbon
 - 2.4.1.1 Base material shall be of Virgin Coconut Shell allowing for high affinity.
 - 2.4.1.2 Particle size shall be 4 x 8 allowing for a range of adsorbent retention.
 - 2.4.1.3 Carbon tetrachloride activity shall initially be at 60 minimum.
 - 2.4.1.4 Hardness number shall be 97 minimum.
 - 2.4.1.5 Density shall be an average of 31 pounds per cubic foot (497 kg per cubic meter).
 - 2.4.1.6 Total ash content shall not exceed 2%.
 - 2.4.1.7 Iodine number shall be greater than 1050.
- 2.4.2 Panels
 - 2.4.2.1 Panels shall be of a V-bank configuration.
 - 2.4.2.2 Panels shall be 26 gauge (.45 mm) galvanized steel.
 - 2.4.2.3 Panels shall hold a minimum of 18 pounds (8.18 kg) carbon each. Panels shall measure approx. 23.625 inches (60 cm) by approx. 23.625 inches (60 cm). Panels shall be approx. 2-inch (5.08-cm) thick minimum.
 - 2.4.2.4 Airflow shall not exceed a face velocity of 65 ft per minute (19.8 meters per minute).
 - 2.4.2.5 Panels shall be bulk refillable.

2.5 Safety Filter(s)

- 2.5.1 MERV 14 (ASHRAE Standard 52.2-1999)
- 2.5.2 Nominal 24" x 24" x 4"
- 2.5.3 Gradient Density Microfiberglass Media
- 2.5.4 Frame: 24 gauge Aluminized Steel
- 2.5.5 Media Separators: Corrugated Aluminum with hemmed safety edge
- 2.5.6 Faceguard on Upstream and Downstream Side of Filter

Pricing unless specifically noted, does not include site preparation, rigging, installation, external electrical and/or plumbing connections, sales taxes, freight or fire suppression. All local code compliance, permits, licenses and inspections are the responsibility of the purchaser.

Factory Inspection

Air Quality Engineering, Inc.'s Minnesota based factory trained technicians are available for equipment inspection and training. This optional service is available for an additional charge per day, plus travel and expenses (prepaid). In order to properly prepare for inspection and to allow for coordination and scheduling, a thirty day advance notice is required.

If you are in a region where Air Quality Engineering, Inc. factory trained technicians are locally available, their individual rates and schedule will vary. For more information or a price quote on factory inspection and start-up service contact Air Quality Engineering, Inc. at 1-800-328-0787.

Fire Suppression

Because this application requires a fire suppression system be included in the duct system, the Purchaser at installation shall include one. This fire suppression system shall be to local building and fire codes and approved by the insurance underwriter. The fire suppression system shall be installed and operational before the air cleaner is put in service.

Notes



Odor Control Modules

Models	AUTOCLEAN® 2000 & F72A	AUTOCLEAN® 4000 & F72B	AUTOCLEAN® 8000 & F72C
Construction Material	Housing and doors are manufactured from 16 gauge cold rolled steel	Housing and doors are manufactured from 16 gauge cold rolled steel	Housing and doors are manufactured from 16 gauge cold rolled steel
Color	Available in black or silver, powdercoated enamel finish	Available in black or silver, powdercoated enamel finish	Available in black or silver, powdercoated enamel finish
Recommended Airflow	Up to 2000 CFM	Up to 4000 CFM	Up to 8000 CFM
Safety Filter Type	MERV 14, metal framed and separated high efficiency microfiberglass	MERV 14, metal framed and separated high efficiency microfiberglass	MERV 14, metal framed and separated high efficiency microfiberglass
Number of Safety Filters	1	2	4
Number of Carbon Panels	8	16	32
Carbon Panel Construction	Panels are manufactured from 26 gauge cold rolled steel	Panels are manufactured from 26 gauge cold rolled steel	Panels are manufactured from 26 gauge cold rolled steel
Total Pounds of Carbon in Panels	144	288	576
Module Weight without Panels	150 lbs.	250 lbs.	500 lbs.
Module Weight with Panels	340 lbs	630 lbs.	1,260 lbs.
Type of Carbon in Panels	100% virgin coconut shell carbon	100% virgin coconut shell carbon	100% virgin coconut shell carbon
Panels Bulk Refillable?	Yes	Yes	Yes
Reversible for Filter Access on Either Side?	Yes	Yes	Yes

Odor Control Modules – Dimensional Data

AUTOCLEAN® 2000 & F72A
Odor Control Module

Top Down View

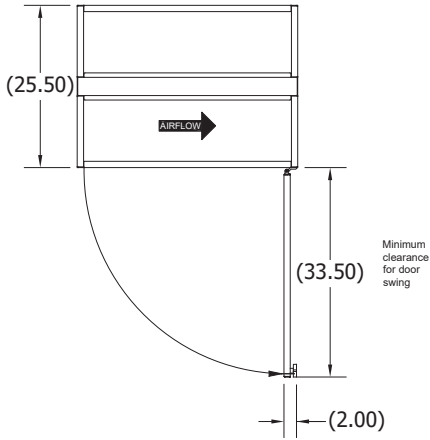

AUTOCLEAN® 4000 & F72B
Odor Control Module

Top Down View

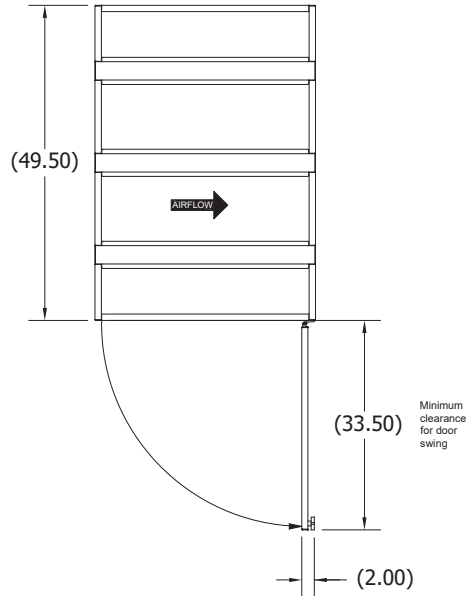

AUTOCLEAN® 8000 & F72C
Odor Control Module

Top Down View

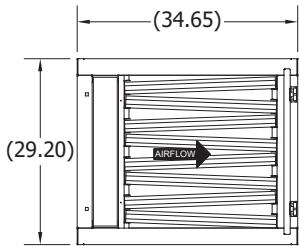
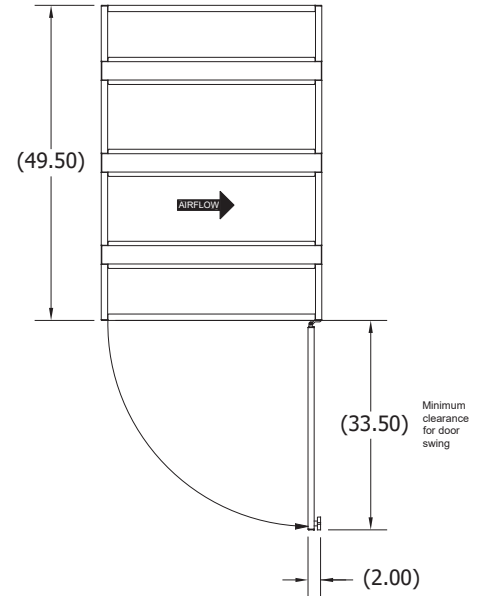

AUTOCLEAN® 2000 & F72A
Odor Control Module

Side View (Facing Access Door)

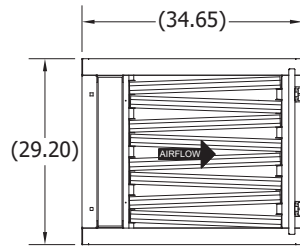

AUTOCLEAN® 4000 & F72B
Odor Control Module

Side View (Facing Access Door)

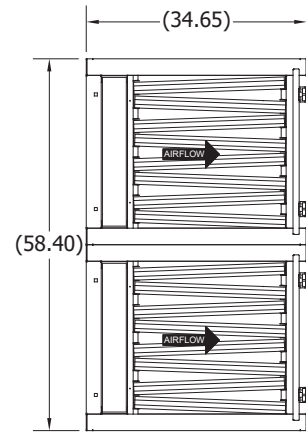

AUTOCLEAN® 8000 & F72C
Odor Control Module

Side View (Facing Access Door)

All dimensions nominal and in inches.

The Original AUTOCLEAN® (F61) and SMOKEMASTER® F72

Proudly designing and manufacturing the AUTOCLEAN® and SMOKEMASTER® in-duct commercial kitchen exhaust purification product lines for delivery in the United States and worldwide.



**AIR QUALITY
ENGINEERING**

Tailored solutions from people who care

air-quality-eng.com

info@air-quality-eng.com

763-531-9823

800-328-0787

763-531-9900 fax

7140 Northland Drive N.
Minneapolis, MN
55428-1520, USA