

Version #7123



BUMPER PULL / TRAVEL TRAILER Installation & User Manual

**QUADRA MANUFACTURING
BIGFOOT LEVELING SYSTEMS**

305 US 131 SOUTH
WHITE PIGEON, MI 49099
800-752-9815 (PHONE)
269-483-9636 (FAX)
bigfootleveler.com



This manual provides general instructions. Many variables can change the circumstances of the instructions, i.e., the degree of difficulty, operation and ability of the individual performing the instructions. This manual cannot begin to plot out instructions for every possibility, but provides the general instructions, as necessary, for effectively interfacing with the device, product or system. Failure to correctly follow the provided instructions may result in death, serious personal injury, severe product and/or property damage, including voiding of the Quadra warranty.



- Failure to follow instructions provided in this manual may result in death, serious personal injury and/or severe product and property damage, including voiding of the component warranty.
- During servicing make sure that the coach is supported according to the manufacturer's recommendation. Lift the coach by the frame and never the axle or suspension. Do not go under the coach unless it is properly supported. Unsupported coaches can fall causing death or personal injury or product or property damage. Use proper personal protective equipment.



- Always wear eye protection when performing service, maintenance or installation procedures. Other safety equipment to consider would be hearing protection, gloves and possibly a full face shield, depending on the nature of the task.
- Moving parts can pinch, crush, or cut. Keep clear and use caution

Platinum Leveling System Controls

Control Panel Operation:

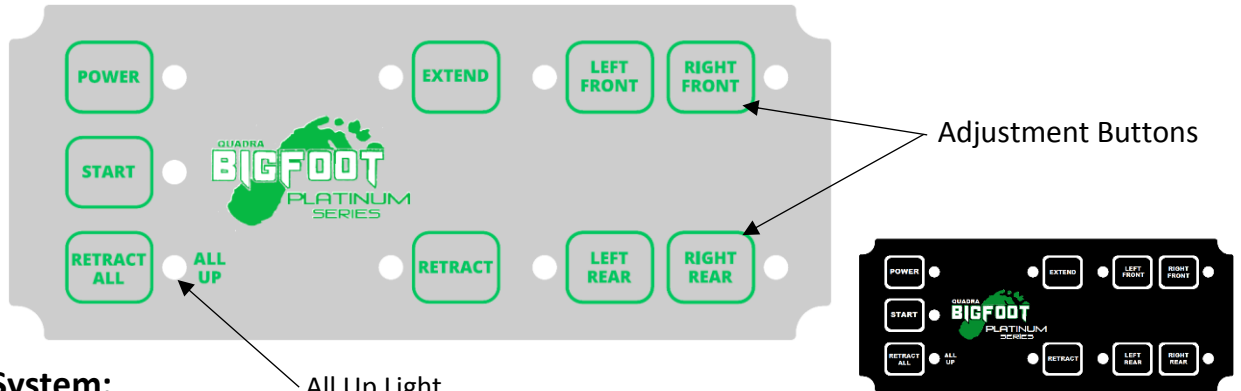

Extend System:

1. Press the **Power** Button (Red LED will come on constant).
2. Press the **Start** Button, this brings the front of the trailer nearly level to the rear and stabilizes the rear as well. (LED will come on until program is finished, pressing any button during operation will cancel program)
3. Done! Trailer is now stabilized, *if* additional adjustments are desired:
 1. Press **Extend** (now in "Extend Mode" LED will come on).
 2. Press & Hold the Adjustment Button for the designated corner(s) of the trailer that is low or high. (Ex. Right or Curb side is low, press & hold RIGHT FRONT & RIGHT REAR until level, driver's side is considered the left side for reference).
4. **Power Off** (panel will automatically shut off after 10 minutes of no activity).

Retract System: *Always visually check that all jacks are fully retracted prior to towing trailer.*

1. Press the **Power** Button (Red LED will come on).
2. Press the **Retract All** Button until the green "**All Up**" light comes on constant. (This process will take up to 60 seconds. After 60 seconds the green light will flash, this means that one or more of the jacks did not fully retract, see troubleshooting)

Pressing "RETRACT" will retract all four cylinders, make sure tongue jack is set to support trailer.

Manual Leveling System Controls

Extend All: Press & hold to extend all four jacks, Retract All: Retracts all four.

For individual operation: Press and release Extend Mode, press and hold corresponding jack you want to extend. Do the same for retract function. In case of limit switch failure or "false all up light" (jack not fully retracted but it's "up" light is on)... Press Retract Mode and run that particular jack to override the limit switch, then replace switch and pin.

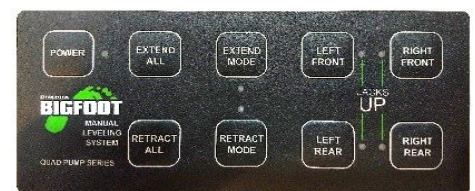

Cylinder Installation & Assembly

Mounting the Cylinders

Pre-assemble jack prior to hanging on previously mounted weld-on bracket.

- Attach foot pad with $\frac{3}{4}$ " thin jam nut using a $1\frac{1}{16}$ " socket.
- Remove port plugs with $\frac{3}{16}$ " allen wrench.
- Install supplied JIC elbow fittings to the bottom & top ports with $\frac{9}{16}$ " wrench.
- **DO NOT** install the extend hose to the top port on central pump systems yet, this will be done later on in installation (due to the length of hose they must go through a bleeding process).
- Place $\frac{1}{4}$ " clevis pin in limit switch barrel then insert threaded limit switch with $\frac{7}{8}$ " wrench.
- For jack locations see diagrams on the following pages, but typically the front jacks should be on exposed A-frame and the rear jacks should be within 60" behind the rear axle.
- If it is a weld-on application, make sure the weld-on bracket is level and you get good penetration to the frame with full welds the entire length of the bracket. Sometimes it is easier to mount jack prior to welding by lifting assembly with floor jack, be sure to verify levelness and ground clearance.
- Hang jack using at minimum of four $\frac{7}{16}$ " x 1.75" grade 8 bolts, hex nuts & lock washers. If you have 17k-lb or larger jacks ($3\frac{3}{8}$ " diameter or larger) you need a minimum of six bolts per jack. Prior to tightening, verify jack is straight & level using carpenter's level. Tighten with $\frac{5}{8}$ " wrench on bolt, $\frac{11}{16}$ " socket on nut, tighten to 70 ft.-lbs. (See Fig. 1)

Fig. 1

The jack pictured in this diagram may not match the jack for your application or kit.

Identifying jacks by diameter:

$2\frac{3}{8}$ " = 8k-lb jack

$2\frac{7}{8}$ " = 12k-lb jack

$3\frac{3}{8}$ " = 17k-lb jack

$3\frac{7}{8}$ " = 24k-lb jack

*Cylinder design may vary,
see next page....*

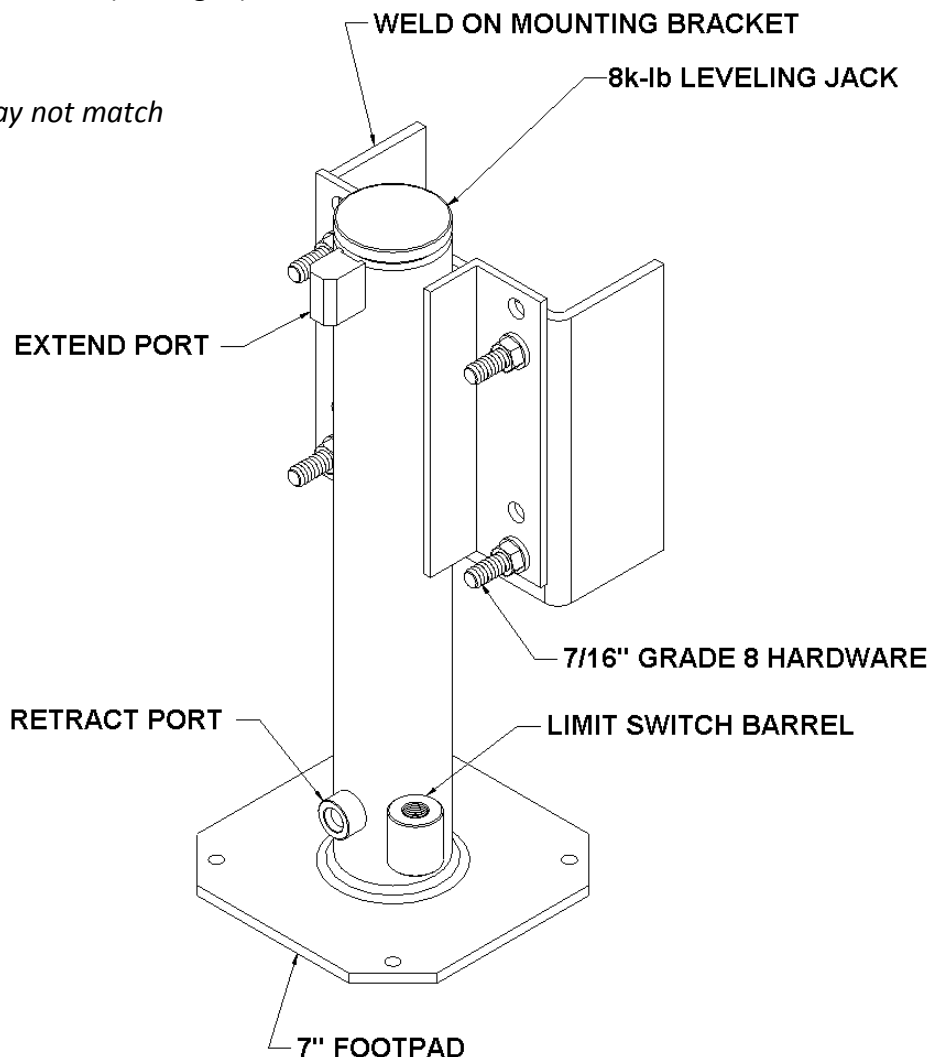

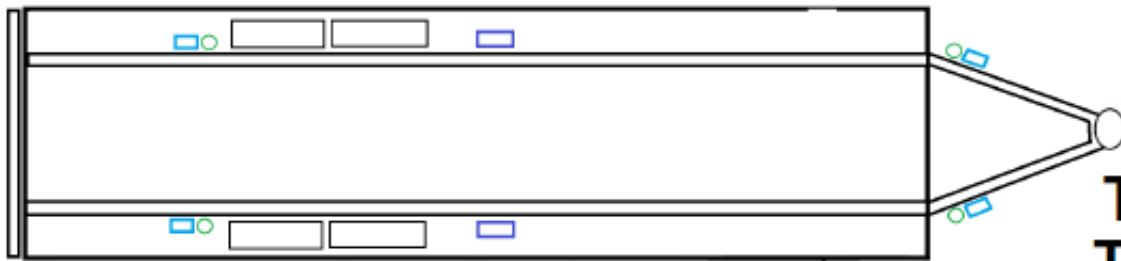

○ CYLINDER
□ QUAD PUMP
□ CENTRAL PUMP

TRAVEL TRAILER

4pt Leveling System Cylinder Layout

Typical pump (central & quad) locations shown above, but are not required and vary from application to application.

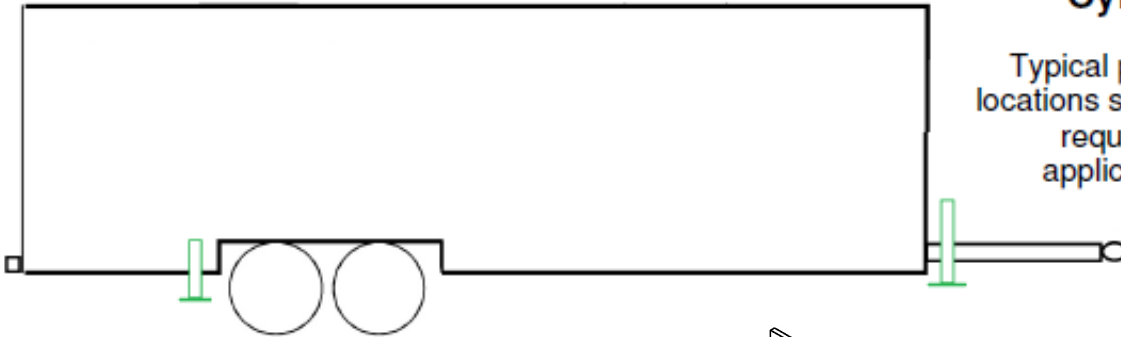

REAR CYLINDER:
#M1014
12k-lb LIFT CAPACITY
14" STROKE

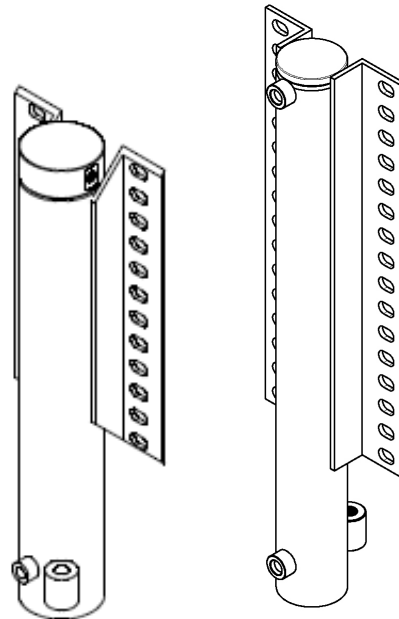
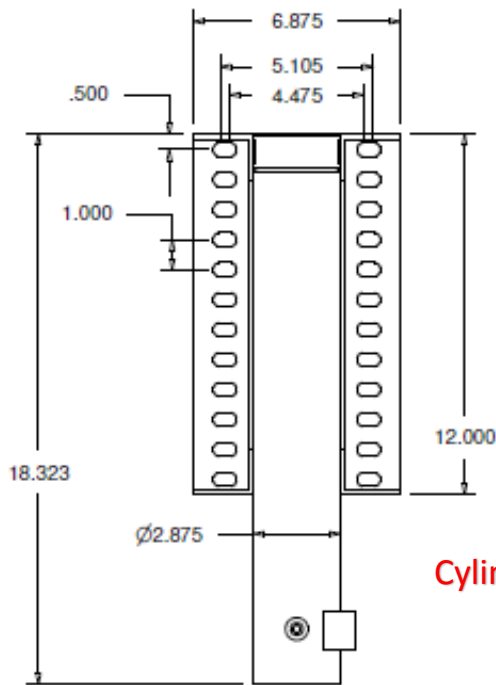

FRONT CYLINDER:
#M0218
8k-lb LIFT CAPACITY
18" STROKE
FULL BRACKET

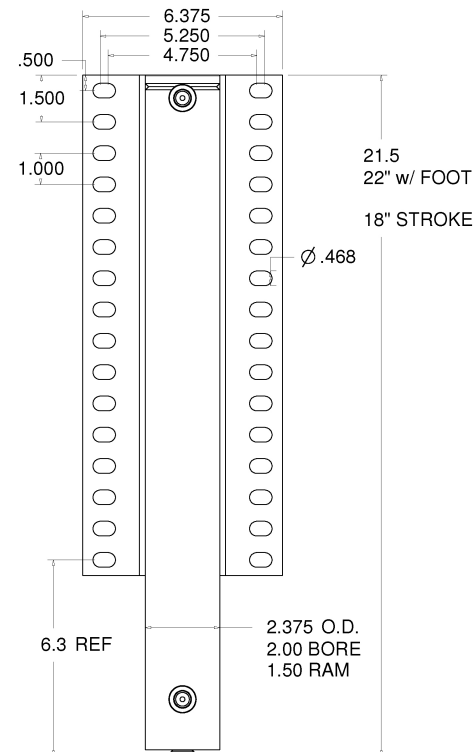

Cylinders or mounting brackets
may vary from shown

**REAR CYLINDER
WELD-ON BRACKET**
#M29320

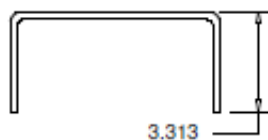

**FRONT CYLINDER
WELD-ON BRACKET**
#M31001

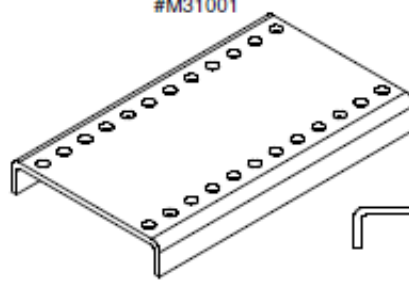

NOTE: Installations may require modifications...

Certain vehicles & RV models may require modifications to the following: Weld-on brackets; Extending limit switch wires & battery cables due to wide range of pump locations; Re-routing generator exhaust, RV plumbing or wiring; Modification to sub-floor brackets or joists, storage boxes & floors. Hydraulic lines in kit are universal/generic and may not fit every application, call Quadra and order any length hose you need separately.

Make sure the proper hardware is used in the proper locations.

Everything should be attached and level prior to tightening.

All hardware to be fastened to following torque specs:

1/2" (5 1/2" & 9" Bolts) = Torqued to 80 ft/lbs.

7/16" (1 1/2" Bolts) = Torqued to 70 ft/lbs.

3/8" (U-Bolts) = Torqued to 45 ft/lbs.

3/4" (Nuts for Foot Pads) = Impact must be used and one to two threads should be visible past nut.

Vertical Tank Assembly for *Central Pump Systems*

Tank Assembly will be pre-assembled & pre-wired direct from factory.

- Mount the pump using a minimum of two 7/16" bolts, nuts & lock washers.
- Plumbing is shown in Fig. 2 below, use 9/16" wrench and be careful not to under or over-tighten the hydraulic fittings. Sometimes marking the hydraulic lines with tape may make it easier.
- **DO NOT** install the top extend lines to the jacks themselves yet, this will be done later in installation.
- The main wire harness will plug directly into the 14-pin connector that is pre-wired to the assembly.
- Route the **ground harness** (attached to ground shown below) to a grounded surface on the vehicle frame.
- Finally installing the plastic three sided tank cover, this should be done later on in the assembly.
- The tank cover will need to be trimmed to your liking around the hydraulic lines. Fasten the tank cover with at least two self-threading screws, be careful not to puncture the plastic reservoir.

Fig. 2 "A" PORTS
EXTEND

"B" PORTS
RETRACT

RIGHTFRONT <

LEFTFRONT <

RIGHTREAR <

LEFTREAR <

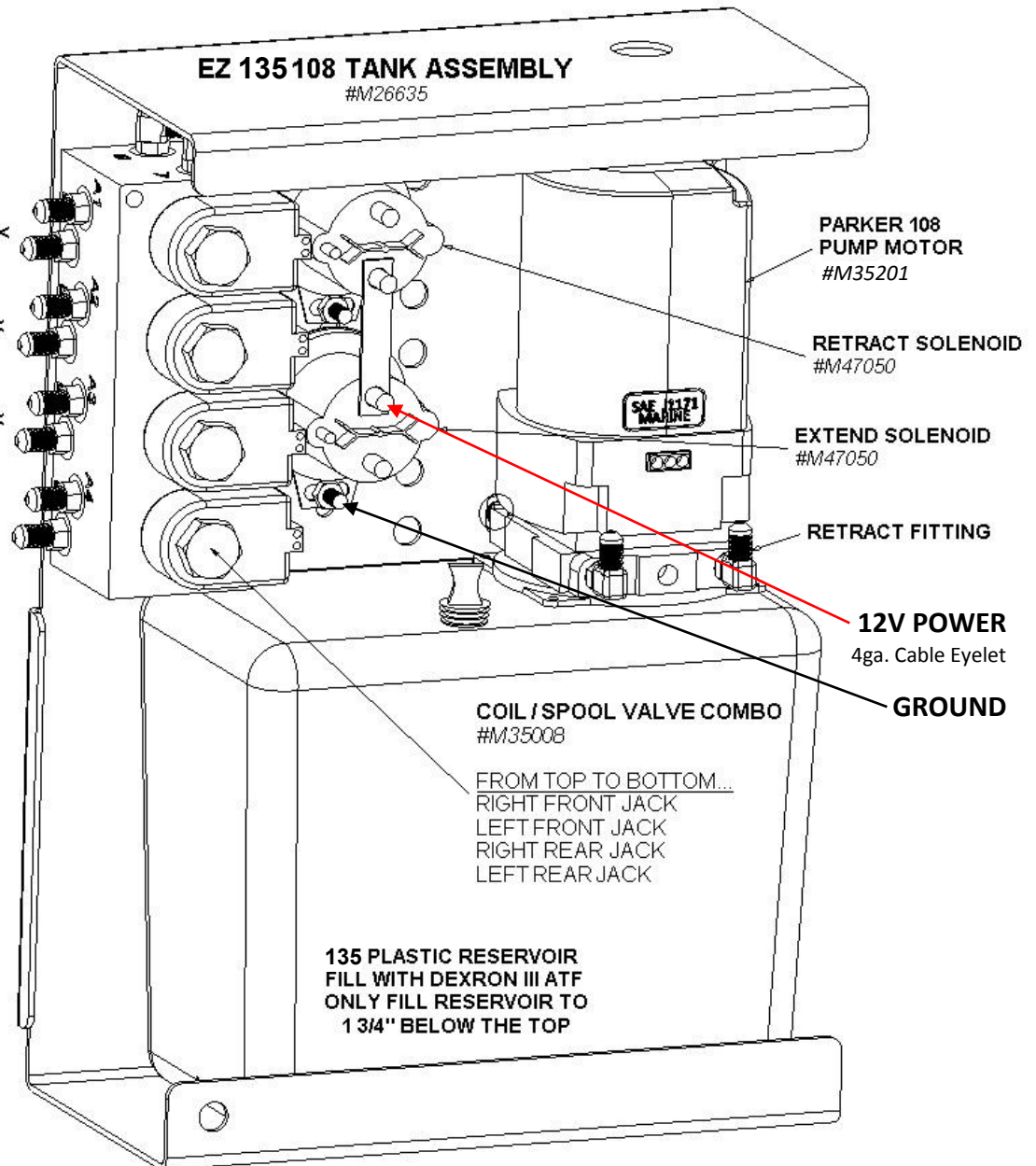

Central tank assembly is typically located near the "center" of the unit, Example: In front of rear axle on driver's side frame rail (outside of rail or between rails).

Quad Pump Systems...

MEDIUM TANK ASSEMBLY

#M26850

OVERALL DIMENSIONS:
 9" WIDE
 12.5" TALL
 5.75" DEEP

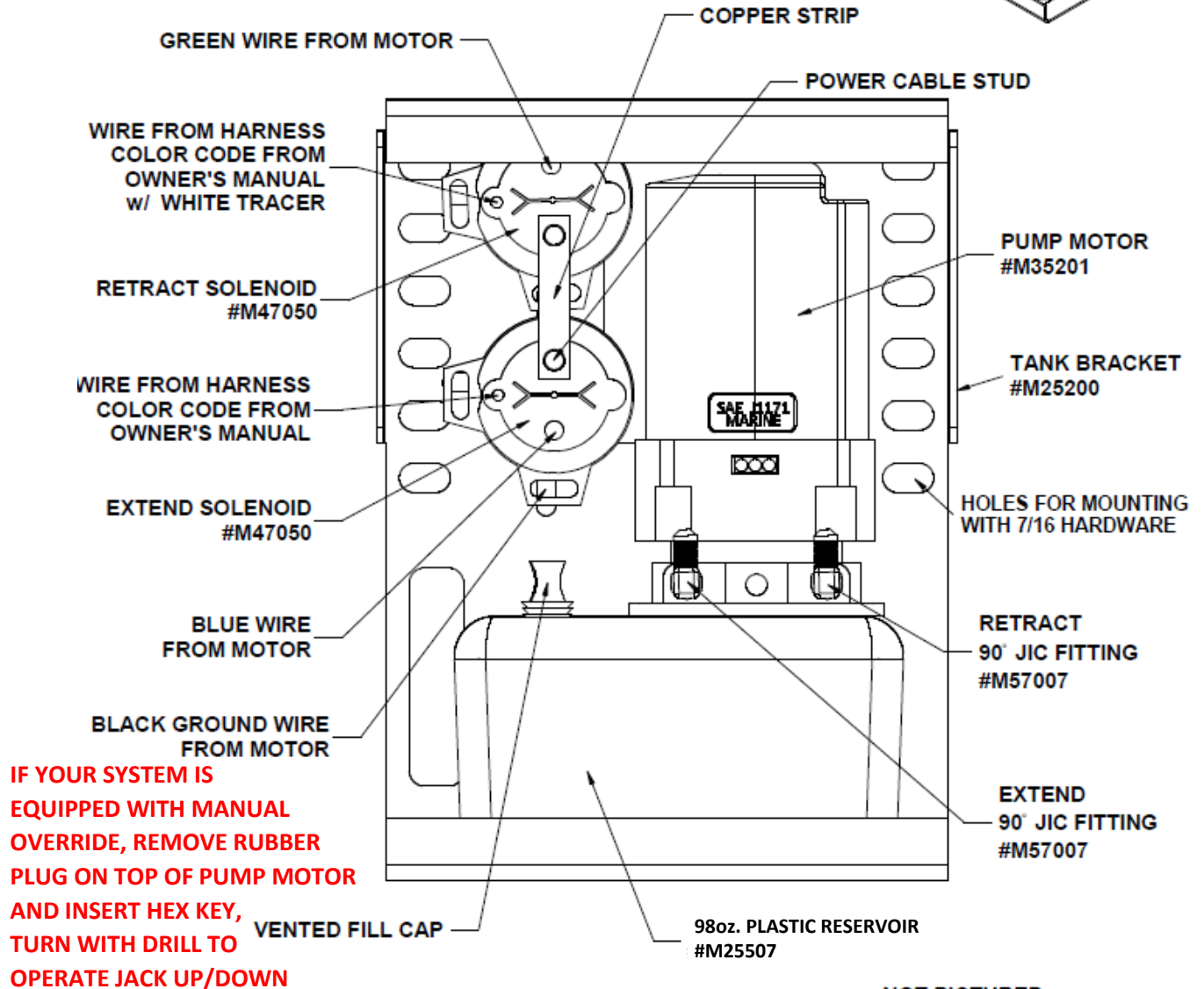
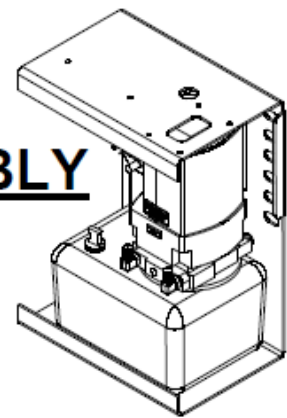

4 PT WIRING HARNESS COLOR CODE DIAGRAM:
 LEFT FRONT: GREEN/WHITE & GREEN
 RIGHT FRONT: BLUE/WHITE & BLUE
 LEFT REAR: GREY/WHITE & GREY
 RIGHT REAR: BROWN/WHITE & BROWN

NOT PICTURED:
 TANK COVER
 (BLACK TEXTURED PLASTIC)
 #M12002

Mounting Tank Assemblies (Quad or Central)

Our tank assemblies are weather resistant and must be mounted vertically and can be mounted externally on the vehicle's frame by drilling holes in the frame or welding a bracket, tanks can be mounted to a cylinder bracket or inside a storage box. Use at minimum two 7/16" or 3/8" bolts per tank assembly. Take care when mounting and running hydraulic lines & wiring to avoid moving parts, exhaust, etc.

Main Wire Harness

Installing the 14-Pin Wiring Harness Central Pump System

The harness has two ends with plugs; the “panel” end has a 14-pin connector & a 6-pin. This end will need to route to the control panel’s location (typically near entry door/front storage compartment). The other end will have one 14-pin connector that will plug directly into the tank assembly. The rest of the harness has two wires: Black & Tan, both of these wires plug directly into the Limit Switch that you installed previously onto each jack. Attach the wire harness to the frame rail (usually inside of rail with other wiring) with p-clips or zip ties safely routing away from any moving suspension parts or exhaust (complying with RVIA regulations). Example diagram on next page...

Installing the 14-Pin Wiring Harness Quad Pump System

The main wire harness will have three wires for each corner: One wire goes to the limit switch (has spade connector) (the limit switch has two wires coming from it, the wire with the eyelet goes to ground, the spade connects to harness). The other two wires (same color except one has a tracer) have female push-on connectors that plug into the operation posts on each solenoid. The battery harness has eyelets at each corner that attaches to the power stud on the lower solenoid (with the copper strip).

See the “Medium Tank Assembly” diagram earlier in the booklet.

The main harness lead has a 14-pin connector at the end, this end will need to route to the panel location. Attach the wire harness to the frame rail (usually inside of driver’s side rail with other wiring) with p-clips or zip ties safely routing away from any moving suspension parts or exhaust (complying RVIA regulations).

Installing the Limit Switches to the Jacks

Central Pump systems, both wires from limit switch plug into harness.

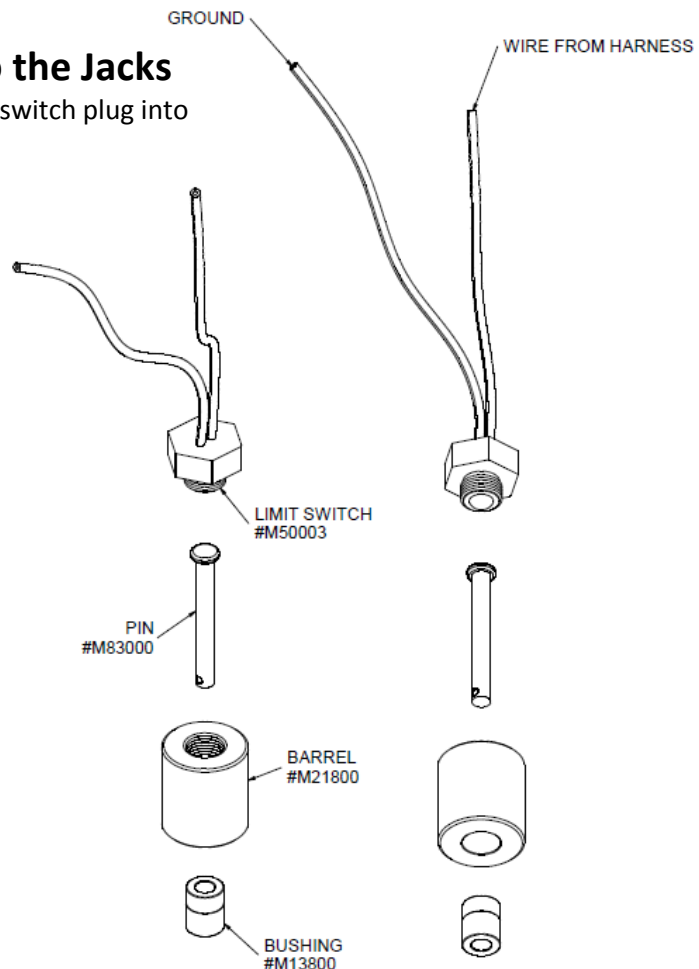

Battery Cable Installation for Central Pump & 2pt Systems

Supplied will be a 4 gauge battery cable that needs to be cut into two pieces.

- The 1st to run from the Solenoid power stud (marked BATT+) to the 80 amp breaker AUX stud.
- The 2nd to run from the BAT stud on the breaker to the Positive Terminal on the coach's house battery.
- Hooking up the power should be the final wiring step so make sure this is done after all the other electrical work is done for safety. The supplied 80 amp breaker should be securely fastened in the battery box. Ground cable (attached to central pump assembly, typically white 10ga. wire should be fastened to vehicle frame or extended to negative terminal on battery.

Installing the Platinum Control Panel

Plug the 14-pin & 6-pin from the harness into the back side. The panel may be mounted in a safe location inside the coach, or inside Quadra's plastic box assembly with the harness loosely coiled in a storage compartment.

Safety feature for Platinum panels: In-line toggle switch to shut power off to the panel to prevent operation while driving down the road from children, etc. Find the red wire from the 6-pin harness that goes to the back of the panel. Cut and splice the included wires to route to the toggle switch that should be located near the Platinum panel for convenience.

Battery Cable Installation for Central Pump Systems

Supplied will be a 4 gauge battery cable that needs to be cut into two pieces.

- The 1st to run from the Solenoid power stud (marked BATT+) to the 80 amp breaker AUX stud.
- The 2nd to run from the BAT stud on the breaker to the Positive Terminal on the coach's house battery.
- Hooking up the power should be the final wiring step so make sure this is done after all the other electrical work is done for safety. The supplied 80 amp breaker should be securely fastened in the battery box.

Installing the Manual Control Panel

Plug the 14-pin harness & 6-pin into back of panel, mount with bezel.

Battery Harness Installation for Quad Pump Systems

Supplied will be a 4 gauge battery harness that must be ran from the coach's house battery to all four pump assemblies at the solenoid power stud (with the copper strip). For the end going to the breaker read below:

- Mount the 120 amp breaker near the battery (usually in the battery box) cut a piece of the battery harness off that is long enough to reach the battery from the breaker.
- Install the eyelet to the now open end of the battery harness and hook it to the BATT post on the breaker.
- Install the eyelet to the short cut piece and hook that to the AUX post on the breaker and to the positive terminal on the coach's house battery.
- Hooking up the power should be the final wiring step so make sure this is done after all the other electrical work is done for safety.

Example below of routing the Quad Pump Manual systems 14-pin wire harness. Diagram represents a vehicle, but principles are the same for trailers. The Central Pump systems harness is similar except that the leads to each corner or jack have only a tan & black wire that plugs into the limit switch and the end of the harness with the 14-pin connector plugs into the pump while the end with the 14-pin & 6-pin connectors plug into the Manual or Platinum panel. Take care to avoid high heat areas and moving parts.

MAIN WIRE HARNESS DIAGRAM

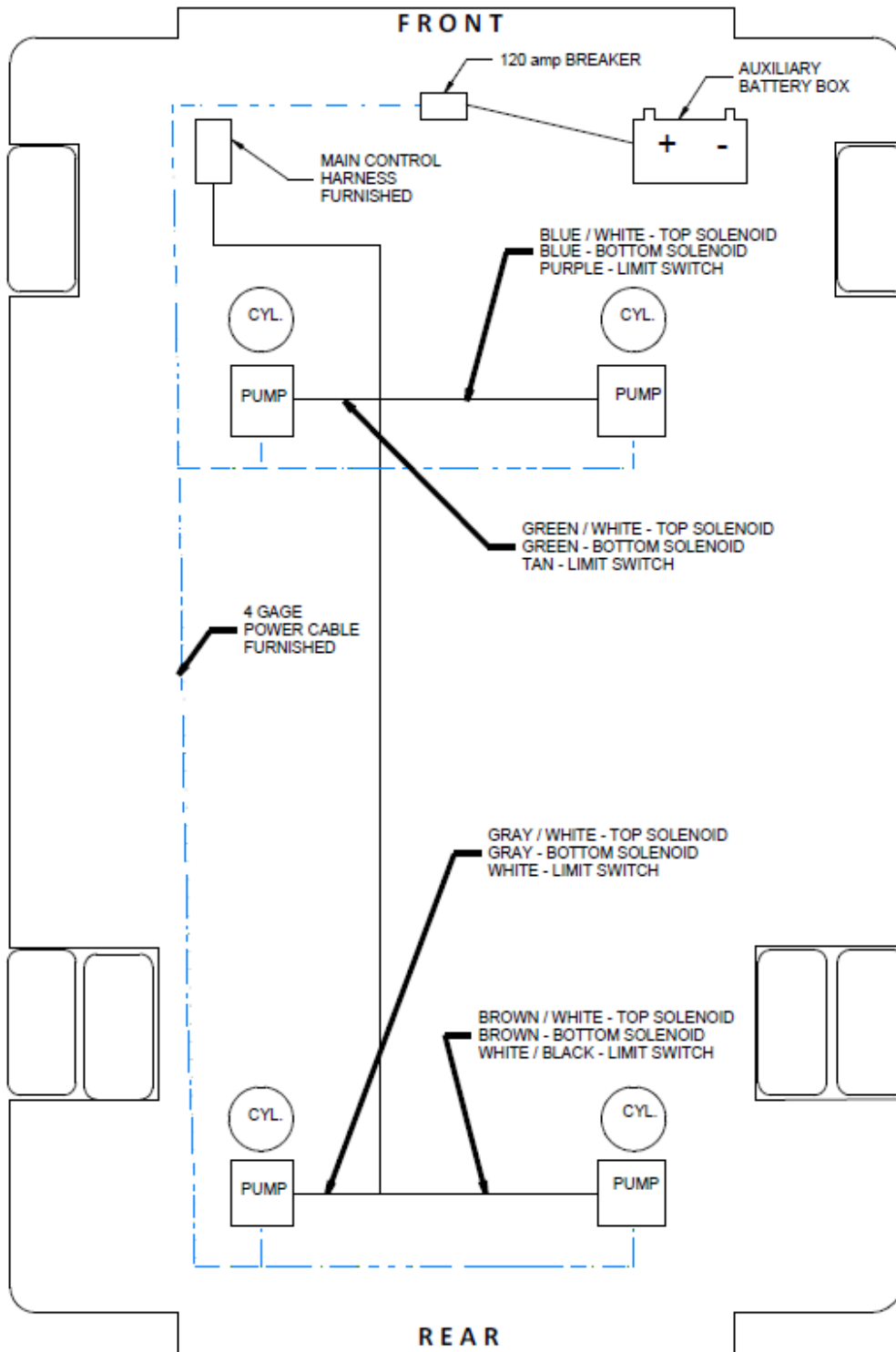

Installing the Quad Pump Control Panel: The 6-pin connector only has three wires: red, yellow and black. The yellow wire is for ignition or accessory hot wire from a vehicle and will not be required to install on a trailer. The red wire needs to attach to a fused 12V power source (7.5 amp fuse). The black wire is ground. The panel is typically mounted near the entry door on a vertical cabinet wall with access behind it.

Central Pump Final Extend Hose Installation & Bleeding the System

During installation of the hydraulic lines, air is internally captured in the hose. Due to this, bleeding the air out of the system is necessary for the system to work properly. This process is done at the end of installation and requires two people and can be messy, so as a warning make sure you are wearing eye protection and have rags ready to use. Make sure all hose fittings are tight on the pump side and the retract side of the jacks. Extend hose fittings should still be un-installed.

- With person #1 running the panel, go into Manual Mode, all jacks should be fully retracted.
- Person #2 (armed with a 5/8" OR 9/16" wrench, safety glasses, rag and a one gallon container) needs to access the left rear jack and place the un-attached extend hose into the empty container.
- Now person #1 will extend that left rear jack from the panel (press & hold button).
- Fluid & air will be spilling out of the port, once a solid stream of fluid occurs, person #1 will release the button on the panel, after fluid stops flowing person #2 should install the hose fitting to the jack.
- Repeat these steps with the rest of the jacks.
- After doing so, extend all jacks fully and let stand for 15 minutes.
- Then retract all the jacks and remove the tank cover and check your fluid level to verify the fluid in the reservoir is around 1 3/4" below the top (ATF Dexron III) do not fill to the top!

Finally install the tank cover, check that all hardware is tight, the sensor is facing the correct way and is mounted level and the house battery is fully charged.

In some instances, the front jacks may need to be dis-mounted from underneath the cab to access the top extend ports during the bleeding procedure.

Bleeding Quad Pump systems

In Manual mode, extend all four jacks to complete extension and leave in this position for 20 to 30 minutes. This pushes all the air out of the lines by weight pressure. After turn panel back on and press Retract.

Troubleshooting - Hydraulic Cylinder/Plumbing Related

What fluid do we use in the system? Automatic Transmission Fluid Dexron III ATF

Cylinders running "choppy"... Bleed the system, if central pump system, try quad pump method first.

Cylinders make loud "squeaking" noise while operating... Spray rams with Teflon spray (dry lubricant).

Hydraulic fluid on footpad or on ground around cylinder... Loose fitting or broken hydraulic line.

Cylinders "creep" down or don't hold pressure when lifting/holding coach...

- Check fluid level, Check for leaks in hydraulic lines/fittings
- Possibly plumbed backwards... (Bottom port on cylinder tube connects to right port on pump, etc.)
- Relief Valves have failed on pump motor... replace motor/tank assembly
- Hydraulic seal failure, check for oil around bottom of cylinder or welds... replace cylinder

Troubleshooting – No “All Up” Light

Manual Leveling/Platinum Control: If the “All Up” light is not coming on it might be a limit switch on one of the jacks. After attempting to retract all four jacks from the panel and doing a visual check to verify that the jacks are indeed retracted but the panel has no “All Up” light. The first step is to extend each jack a few inches and individually retract one at a time. Sometimes the foot pad retracts crooked and doesn’t fully engage the pin. If that doesn’t work, with the jacks fully retracted, press the RETRACT button on the panel and manually pull each limit switch pin up to see if that engages the switch, if the panel shuts the pump off then that limit switch is not engaging properly. To fix this, it could be the foot pad is loose, remove & re-tighten the ¾” nut with a 1 1/16” socket with an impact wrench. If this does not work you can get a “vacuum cap” at your local hardware store for the ¼” diameter pin which extends the length of the pin and completes the circuit.

If you have an “All Up” light but your jacks are NOT fully retracted, we call this a false all up light, this means you have a bad limit switch (they can stick in the “passing” position due to build-up of road debris or rust).

To get you out of a jam or to bypass this... Central pump systems: disconnect the wires to the limit switch, and plug the two wires from the harness that usually go to the limit switch and plug them into each other (black & tan wires) this closes the circuit and allows the jack to be retracted. Quad pump systems: connect the colored wire from the main harness and connect it to the ground wire from the limit switch (or to frame).

If rear jacks are hanging too low to the ground with the jacks retracted fully, check underneath the coach and check to see if the jack can slide up one row of holes. If this can be done, make sure you raise both rear jacks the same height and tighten each mounting bolt to 70 ft/lbs. If your coach is equipped with an airbag system, just increase air pressure slightly to raise the coach.

If a single jack on a central pump system is simply not working properly, the **valve or coil** to that particular jack might be bad. To replace, simply call or go online to order part number **#M35008**.

Panel won’t turn on, system won’t run, clicking noise, panel lights flash...

Battery low, panel won’t turn on = coach battery, the system relies on the house battery. The battery needs to be nearly 100% charged for the system to work, it doesn’t make a difference if the coach is new, that doesn’t mean the battery is fully charged or even good. Battery’s don’t charge instantaneously, so one can’t just expect to hook it up to a charger and the system will work immediately, if the battery is good, then the unit might have a ground issue.

Panel is on, but pump(s) are not working OR solenoids clicking but pump/motor is not running...

Auxiliary Ground Cable

Sometimes required for heavily coated frames, solenoids need a 10 gauge wire to be attached to one mounting stud for both solenoids on each pump assembly (central or quad) that isn’t working properly to the vehicle’s frame for optimum performance.

Rocker Switch Controls

Included is a harness (#M43800) that routes from the tank assembly to the rocker control switch. The red wire is the 12V power, this goes from the power stud on the tank assembly (on copper strip with 5/16" studs from solenoids) to the center post on the switch. The black wire is ground & is not needed for this switch. The grey wire goes from the retract operation post on the retract solenoid to the post labeled "1" on the switch. The blue wire goes from the extend post on the extend solenoid to the post labeled "3" on the switch. The switch is not waterproof & must be installed inside the coach.

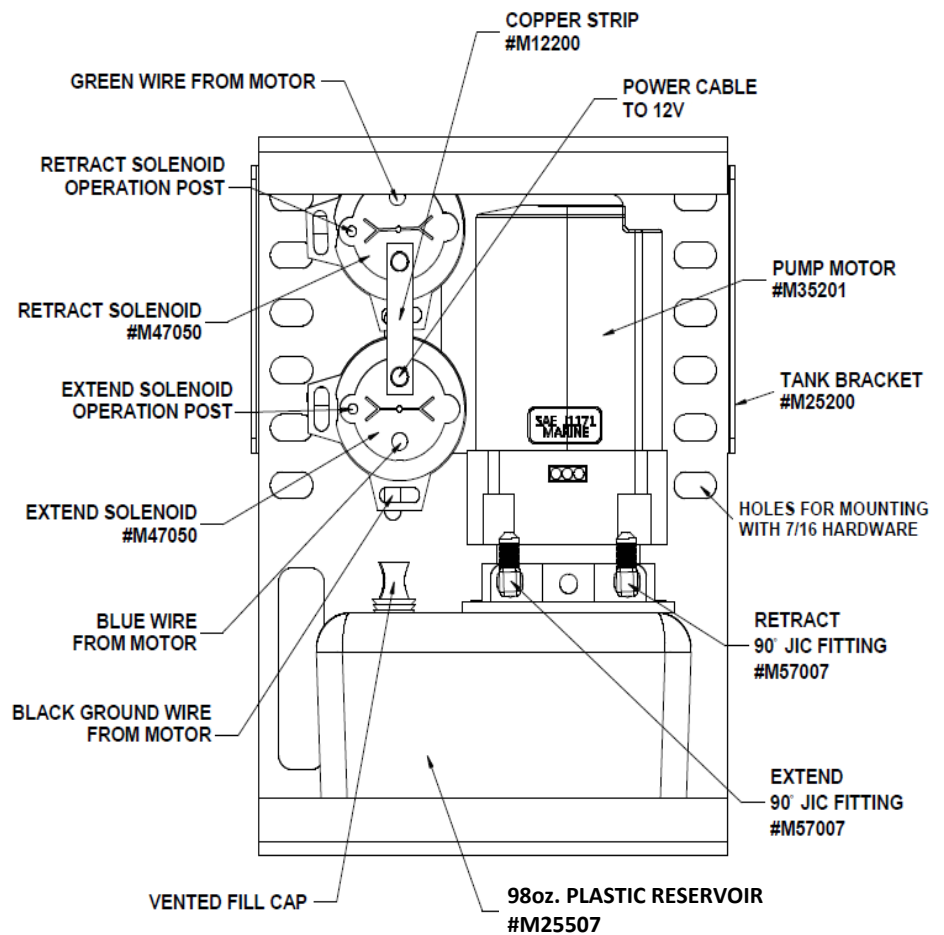

Typical Plumbing

For "Slave" Systems (one pump, two jacks)

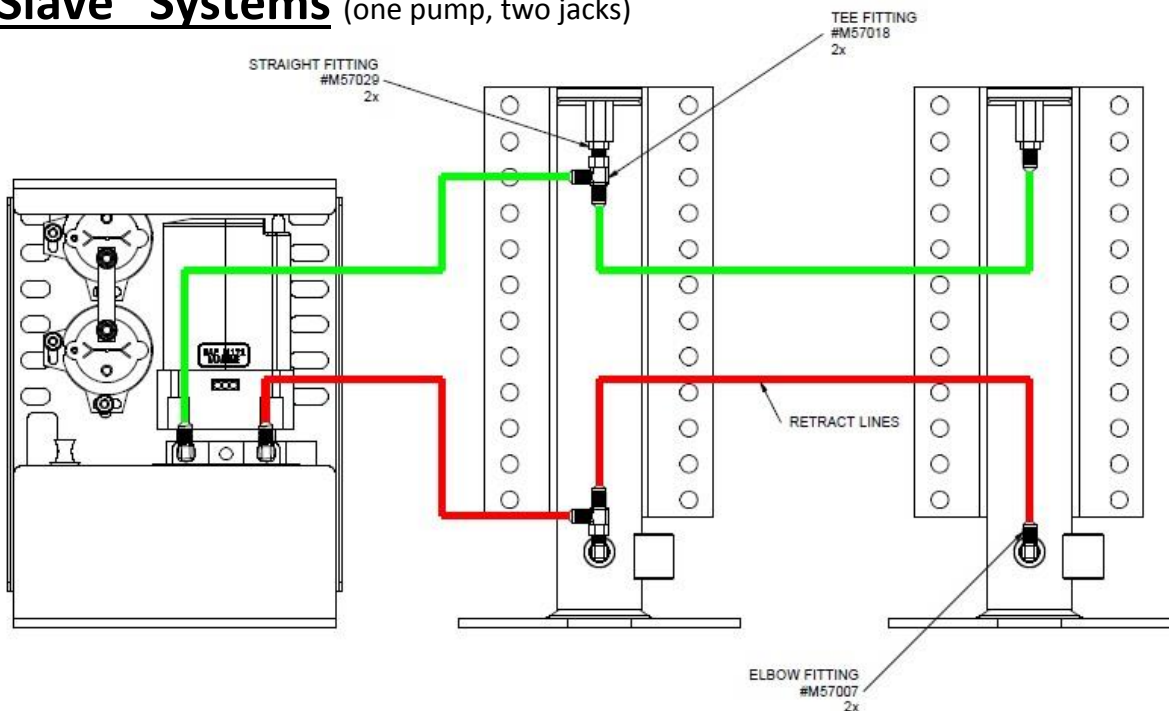

VERSION #1: (SHOWN) THE "TEE" FITTINGS MOUNTED TO THE DRIVE JACK.

VERSION #2: INCLUDES MOUNTING THE "TEE" FITTINGS TO THE PUMP FITTINGS.

VERSION #3: RUNNING TWO LINES FROM THE PUMP AND PLACING THE "TEE" FITTINGS IN-LINE, THEN RUNNING INDIVIDUAL LINES TO EACH JACK FROM THE "TEE" FITTINGS.

WARRANTY GUIDE

Owner must activate warranty! Via Phone or Website

OEM Installed Quad/Central Pump Systems: 1 year parts and labor

Platinum Central Pump System: Lifetime Cylinders, 2 years parts, 1 year labor

Automatic Leveling System: Lifetime Cylinders, 2 years parts, 1 year labor

Manual Leveling Quad Pump System: Lifetime Cylinders, 2 years parts, 1 year labor

1 & 2 Point Round Leg Stabilizing Systems: 1 year parts and labor

Should the product be defective due to workmanship and/or material flaws,
we will repair/replace the defective material.

Core charges may be applied and refunded on certain components.

Quadra is NOT responsible for:

- **Freight on warranty parts.**
- **Replacing footpads, bolts, loose or bent brackets or fluids lost as a result of failure to maintain the system, Ex. loose/missing footpads, loose mounting brackets/hardware from not re-torquing after initial use, etc.**
- **Damages caused by abuse, misuse, negligence, misapplication, error of operation, accidental or purposeful damage or faulty installation, including but not limited to hoses, fittings & wiring components. Example, bent limit switch pins from hitting ground while driving, missing SnapPads, operating system with rear tires off the ground, modification to system, etc.**
- **Liability for loss to the vehicle, or apparatus or property, loss of time, manufacturing costs, labor, material, loss of profits, consequential damages (direct or indirect).**
- **For transportation to and from a service center, onsite service calls to or from the customer, damage from road hazard, loss of salaries, commissions, lodging, towing charges, bus fares, car rentals, fuel expense, telephone charges, inconvenience compensation while repairing or replacing a defective part or material.**

This warranty voids all previous issues. Effective date: 7/11/2023

OWNERSHIP MUST BE REGISTERED WITHIN 30 DAYS FROM THE DATE OF PURCHASE TO ACTIVATE WARRANTY. Do it online at BIGFOOTLEVELER.com!

Prior to any work being done an **authorization number must be obtained** by calling

269-483-9633 for Warranty Parts or Service Labor. For full warranty transcript just contact us!

Service labor based on a flat rate schedule determined by Quadra for authorized work performed will be reimbursed.

This will eliminate much diagnostic time and avoid refusal of unauthorized claims.

Many problems may be resolved by contacting a Quadra service representative.

Provide the system serial number here _____