



SM-5300X B CON

PC Based System Scale Printer



SM-5300X B CON

Features

- 10.1" capacitive touch display
- Linerless with auto-cutter
- Video playback capability
- e.Label with Hi-Touch
- InfoTag
- Speed ID
- Queue Management
- Waste Management
- DIGI Management Console (DMC)

External Dimensions (mm/in)

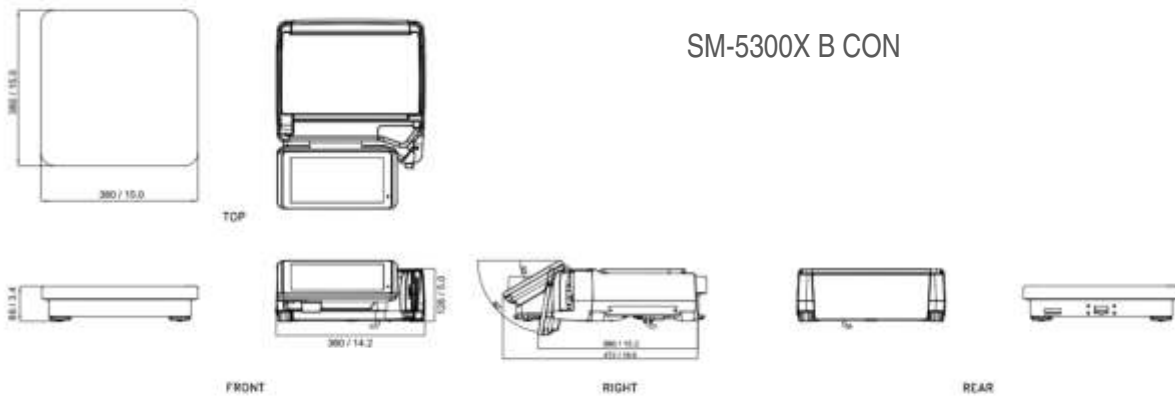

Specifications

| Mode | SM-5300X B CON | |
|---------------------------|--|---|
| Dimension | W×D×H (mm/in) (Console Only) | 360 x 472 x 128 / 14.2 x 18.6 x 5.0 |
| Dimension | W×D×H (mm/in) (Load Cell) | 380 x 380 x 86 / 15.0 x 15.0 x 3.4 |
| Operator Display | 10.1" WSVGA with Capacity Touch (1024 x 600) | ○ |
| | 12.1" TFT SVGA with Touch (800 x 600) | — |
| | 19" TFT SVGA with Touch (1280 x 1024) | — |
| Display Resolution | | 1/3,000, 1/6,000 & 1/7,500 |
| Label Receipt | Types | Liner |
| | Roll Diameter | 125mm/4.9in (Max) |
| | Roll Width | 70mm/2.7in (Max) |
| | Print Width | 71mm/2.8in (Max) |
| | Printing Speed | Up to 150mm(5.9in) / second* |
| | Print Resolution | 300 dpi |
| Power Source | | AC 100 / 110 or 220 / 230 / 240 Volts (50 / 60Hz) Auto Switch |
| Operating Temperature | | 10°C to +40°C |
| Humidity | | 15% to 85% RH |
| Standard Interface | | Ethernet 10 / 100 Base T, 4 x USB 2.0, RJ11 |
| Net Weight (Console Only) | | 7 kg / 15.4 lb |
| Net Weight (Load Cell) | | 9.4 kg / 20.7 lb |

| | |
|----------------|---|
| Options | Wireless LAN IEEE 802.11 a / b / g / n / ac, Base Station, e.Lable with Hi-Touch, InfoTag, Queue Printer, NF-02, Speed ID & Wristband |
| Factory Option | Linerless Printer with Auto-Cutter |

* To achieve maximum print speed, high sensitivity thermal paper is necessary
 **All the images are used for illustration purpose only.
 ***Console variant is available



• Specifications are subject to change without prior notice
 • Meet or exceed OIML Class III requirements

DIGI AMERICA Inc.

1/2022

76 Veronica Ave, Somerset NJ 08873 USA
 Tel: (732) 828 3633
 Email: Marketing@us.digi-group.com
 Web: www.digisystem.com/us

