



SM-5300X

PC Based System Scale Printer



SM-5300B X

External Dimensions (mm/in)

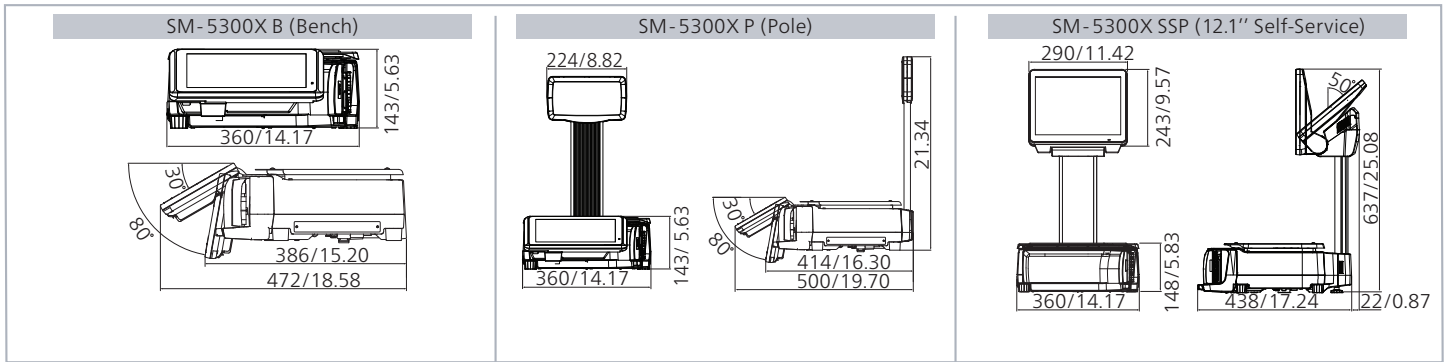

Specifications

Interval Type	Single Interval	Multi-interval	Multi-Interval kg
Capacity	Max. 30 lb	Max. 30 lb	Max. 15 kg
Scale Interval	e = 0.01lb	e = 0.005/0.01 lb	e = 2/5 g
Weighing Range	0.20-30 lb	0.20-30 lb	40 g-15 kg

Model	SM-5300X B (Bench)	SM-5300X P (Pole)	SM-5300X SSP (12.1\" Self-Service)		
Dimension WxDxH(mm)	360 x 472 x 143	360 x 500 x 542	360 x 481 x 637		
Operator Display	10.1\" with Capacitive Wide Touchscreen (1024 x 600)	○	—		
	12.1\" TFT SVGA with Touch (800 x 600)	—	○		
Customer Display	19\" TFT SVGA with Touch (1280 x 1024)	—	—		
	7\" WVGA (800 x 480)	○	—		
	10.1\" WVGA (1024 x 600)	—	—		
Display Resolution	1 / 3,000, 1 / 6,000 & 1 / 7,500				
Types	Liner	Linerless With Auto-Cutter			
Roll Diameter	125mm (Max)	95mm (Max)			
Label / Receipt	70mm (Max)	61 mm (Max)			
Paper Width	71mm (Max)	62mm (Max)			
Printing Speed	Up to 150mm / second*	Up to 150mm / second*			
Print Resolution	300 dpi	300 dpi			
Power Source	AC 100 / 110 or 220 / 230 / 240 Volts (50 / 60 Hz) Auto Switch				
Operating Temperature	-10°C to +40°C				
Humidity	15% to 85% RH				
Standard Interface	Ethernet 10 / 100 Base T, 4 x USB 2.0, RJ11				
Net Weight	10.7 kg	11.7 kg	13.2 kg	13.3 kg	17.0 kg
Add-on Option	Wireless LAN IEEE 802.11 a / b / g / n / ac, Base Station, e.Label with Hi-Touch, InfoTag, Queue Printer, Speed ID				
Factory Option	Linerless Printer with Auto-Cutter				



* To achieve maximum print speed, high sensitivity thermal paper is necessary.
 ** All the images are used for illustration purpose only.



• Specifications are subject to change without prior notice
 • Meet or exceed OIML Class III requirements

DIGI AMERICA Inc.

76 Veronica Ave, Somerset NJ 08873 USA
 Tel: (732) 828 3633
 Email: Marketing@us.digi-group.com
 Web: www.digisystem.com/us

