



SIGNETMARINEInc.
signetmarine.com

SL 172

Instruction Manual

1500 Pier C Street
Long Beach, CA 90813
(310) 320-4349
www.signetmarine.com
service@signetmarine.com

TABLE OF CONTENTS

I. Introduction.....	1
II. Installation.....	3
III. Operation.....	8
IV. Preventative Maintenance.....	11
V. Accessories and Spare Parts.....	12
VI. Warranty Statement.....	12
Appendix I Specifications.....	13
Appendix II Trouble Shooting Chart.....	15

FIGURES

Figure 1 Instrument Display Dimensions.....	1
Figure 2 Mushroom Transducer Dimensions.....	2
Figure 3 Contents.....	ii
Figure 4 Transducer Installation Locations.....	3
Figure 5 Completed Transducer Installation.....	4
Figure 6 Dip Switch Pack.....	6
Figure 7 Position of Dip Switch.....	6
Figure 8 Bulkhead Mounting Diagram.....	7
Figure 9 Electrical Connections.....	7

MK 172 DEPTHSOUNDER
INSTRUCTION MANUAL

I. INTRODUCTION

This manual contains description, specifications, and instructions for installation, operation, and maintenance of the MK 172 Depthfinder System, shown on the title page, manufactured by Signet Scientific Company. Please read all of this instruction manual. It will answer most user questions. When the instructions are carefully followed, problems arising from improper installation or operation can be prevented. If further assistance is needed, notify your Signet dealer, or your nearest authorized warranty repair station (addresses furnished on request), or Signet Scientific Company.

The MK 172 Depthfinder System is intended for use on sailboats and features advanced microprocessor logic with an integral firmware program. The design combines low power drain with precise accuracy and high reliability for the most demanding marine applications under both racing and cruising conditions. This system is the result of continuous development by marine-instrument specialists. Under normal conditions, the MK 172 is sensitive to bottom contour variations as small as one-tenth of a foot. The MK 172 System consists of two major components:

- a. An instrument display (MI 7240), mounted near the helm, that contains the electronics, a liquid crystal display (LCD), audible alarm, and an ALARM enable/disable switch. Internal circuitry includes a presettable feet/meters (FT/M) select switch and presettable keel offset binary DIP switches.
- b. A model MI 7285 Mushroom-style Thru-Hull Depth Transducer. The transducer includes an integral 35-foot, 2-conductor shielded interconnect cable.

Figures 1 and 2 show the dimensions of both the display and the transducer.

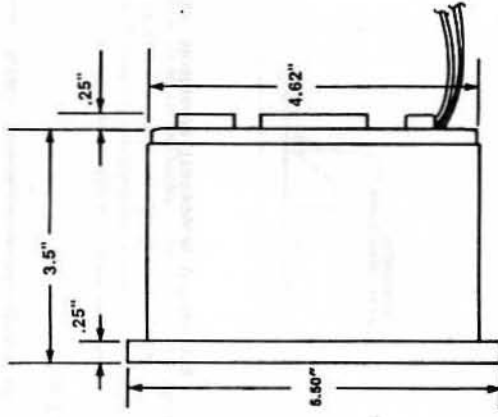

Figure 1. Instrument Display Dimensions

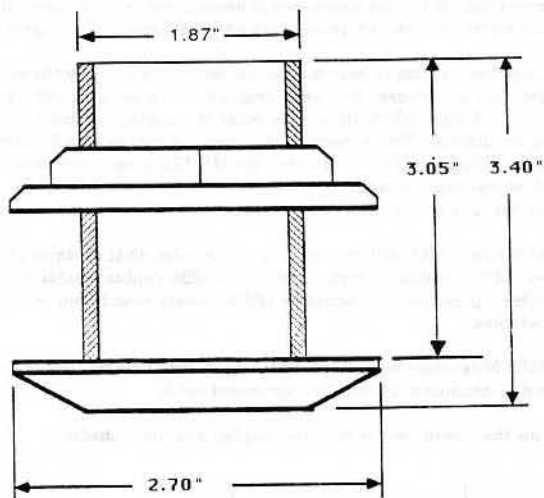

Figure 2. Mushroom Transducer Dimensions

II. INSTALLATION

This section contains unpacking and installation instructions for the Signet MK172 Depthsounder System.

UNPACKING AND INSPECTION

The MK172 systems are shipped in special containers designed to provide full protection under normal transit conditions. Immediately upon receipt, the shipping container should be inspected for evidence of possible damage incurred in transit. Any obvious damage to the container, or indications of actual or probable equipment damage, should be reported to the carrier company in accordance with instructions on the form included in the container. When unpacking your MK172, make sure you have received everything.

The MK172 package contains the following items:

1. MK172 Indicator Display (M17240)
2. Indicator Mounting Clamp Kit (M0201-1)
3. Protective Cover (M0212-1)
4. Transducer Assembly with nut and 35' Integral Cable (M17285)
5. Instruction Manual and Warranty Card (M17290)

Please fill out and return the warranty card as soon as possible.

TRANSDUCER INSTALLATION

The transducer should be mounted in the hull, as near to the center line as possible, and forward of the keel. The mounting area should be free from protruding fittings, with smooth water flow (minimum turbulence). A clearance radius of five inches is necessary inside the hull (in the bilge) for transducer installation and removal.

Special Location Tips

Proper installation of the transducer is of utmost importance for obtaining optimum depthsounder performance. Figure 4 demonstrates the most popular installation position. When choosing a mounting position for the transducer, be sure to consider cable length. The standard cable length is 35 feet. Cable lengths cannot be increased.

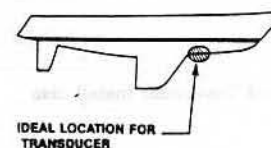

Figure 4: Transducer installation location.

NOTE

If hull thickness is less than 3/4 inch, a backing plate should be used on inside of hull at transducer location.

- Remove boat from water.
- Select location on center line, forward of keel in area of minimum water turbulence. Transducer should be at least 18 inches from keel. Allow minimum 5-inch clearance radius for accessibility inside hull.
- Drill 3/8-inch diameter pilot hole through hull (and backing plate, if used).
- Cut 1-7/8-inch hole through hull.
- Apply bedding compound to inner surface of transducer flange and insert transducer shank through hole from outside hull. Verify proper fit. Small amount of bedding compound should exude evenly around outer edge of flange.
- From inside hull, install large flanged nut on transducer shank. To properly seat transducer, tighten nut firmly with wrench.
- Carefully wipe off excess bedding compound from around transducer flange. Figure 5 shows completed transducer installation.

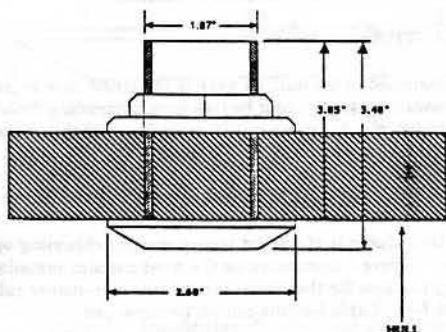

Figure 5. Completed Transducer Installation

INSTRUMENT INSTALLATION

The instrument/indicator may be installed in a bulkhead or instrument panel. The location must have a clear diameter of 5.50 inches and a rear clearance of 5 inches (See Figure 1). The installer should have available the following installation tools:

- 4.5-inch diameter hole saw
- Screwdriver
- Bedding compound

CAUTION

Do not use polysulphide bedding compounds such as 3M 3700, Boat Life, or Life Caulk on instrument/indicator. Use silicone, non-hardening bedding compounds such as GE Silicone Seal.

Presetting

Before installing the instrument/indicator, the DIP switches must be preset, since they may become inaccessible after installation. The DIP switch pack is located on the component side of the main board assembly. The DIP switch contains four miniature rocker type switches - labelled 1 2 3 4. This is shown in Figure 6.

Remove three screws from sides of instrument housing; they secure back panel to housing. Gently pull back panel away from housing. Entire electronics assembly is attached to back panel, and DIP switch pack is at left on board assembly, as shown in Figure 7.

The first switch (#1), is used to select feet or meters. The other switches are used in a binary format to set the keel offset (in feet).

To set the indicator to display depth in meters, push switch #1 to the "OPEN" position. If feet are required, depress the switch to the "number" position.

To set keel offset, first determine the vertical distance from the transducer location in your boat to the bottom of the keel. (The offset control can only handle whole numbers.) If, for example, your keel is 3'7" below the transducer, the number 4 should be selected on the keel offset switch. Table 1 shows the switch positions versus the desired keel depth.

TABLE 1

KEEL OFFSET	SWITCHES		
	2	3	4
0	#	#	#
1	OPEN	#	#
2	#	OPEN	#
3	OPEN	OPEN	#
4	#	#	OPEN
5	OPEN	#	OPEN
6	#	OPEN	OPEN
7	OPEN	OPEN	OPEN

OPEN = Rocker arm pushed down on OPEN SIDE of DIP switch.

= Rocker arm is pushed down on "number" side of DIP switch.

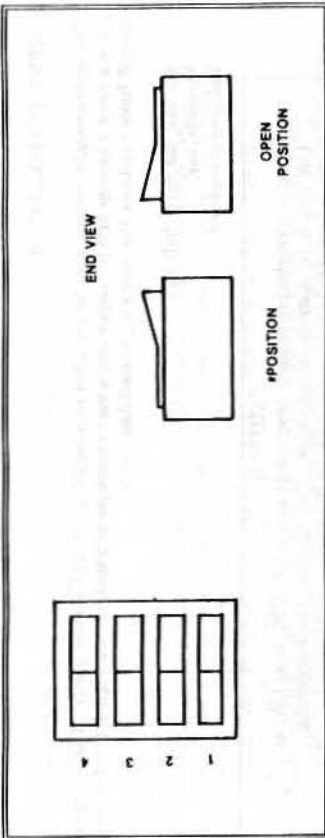

Figure 6. Dip Switch Pack

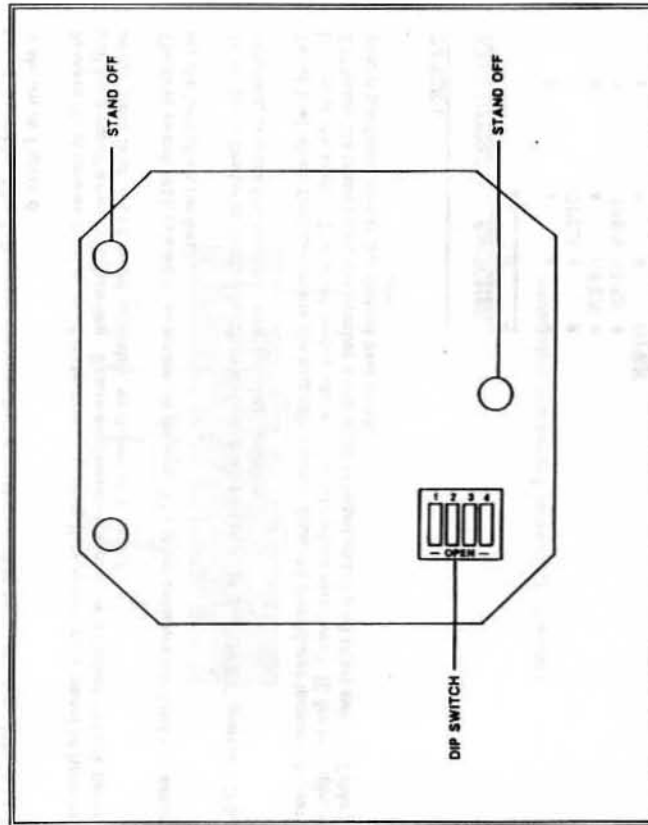

Figure 7. Position of Dip Switch on PC Board Assembly (M17242)

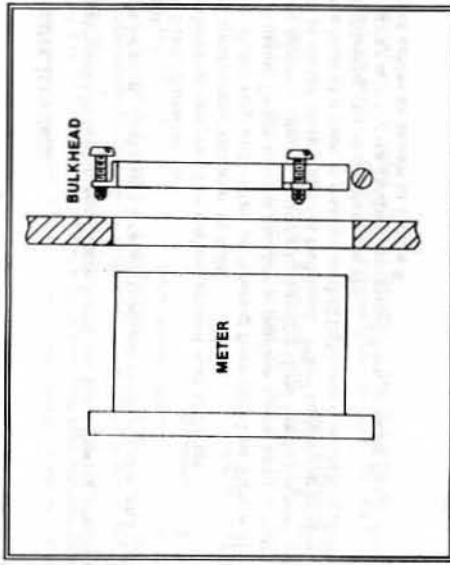

Figure 8. Bulkhead Mounting Diagram

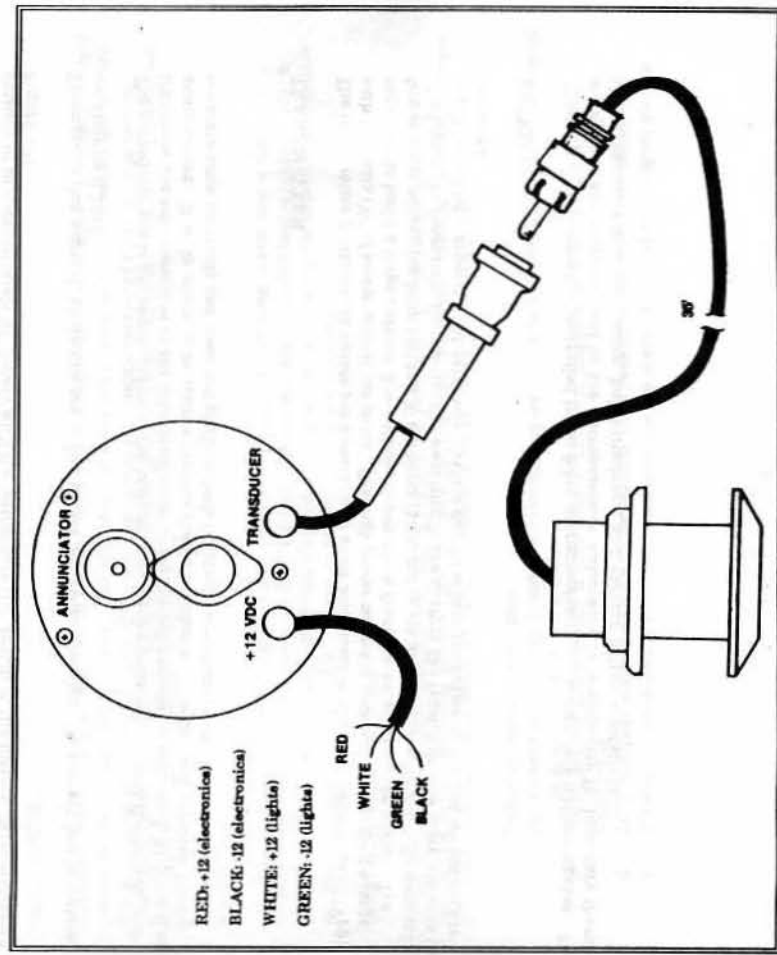

Figure 9. Electrical Connections

Instrument/Indicator Installation

To install the instrument/indicator, see Figure 8 and use the following procedure:

- a. Choose location. Make sure location is within reach of cable, and that proper clearance is present.
- b. Cut 4.5-inch diameter hole.
- c. Apply bedding compound or sealant around rear of flange.
- d. Insert instrument/indicator in hole.
- e. Loosen clamp ring and install on housing from rear (see Figure 8).
- f. With housing flange against bulkhead, position clamp against rear of bulkhead and tighten securely against housing by turning three bracket screws clockwise until housing flange is seated snugly against bulkhead. When tightening bracket screws, tighten each screw a little at a time in rotation so that tightness is equally applied. Do not overtighten; overtightening can cause clamp to slip.
- g. Wipe away any excess bedding compound from housing flange and bulkhead.
- h. Connect cables as shown in Figure 9.

III. OPERATION

The MK172 system operates from three feet to 200 feet with the feet/meters DIP switch in the Feet (FT) position or to approximately 61 meters with the feet/meters DIP switch in the meters (M) position (see Figure 10).

Throughout this manual, all depths are in feet unless otherwise specified. To convert feet to meters, multiply by 0.3048.

The transducer sends ultrasonic pulses to the bottom, receives the pulse echoes from the bottom, and transmits the echo reception to the instrumentation where the information is processed, displayed, and annunciated. It is, in effect, a miniature loudspeaker/microphone. It sends and receives during separate time intervals and does not perform both functions simultaneously.

TRANSMITTER

The transmitter produces six pulses per second (pps) at an amplitude of 450 volts peak-to-peak (Vpp) with 63 watts (W) of power output per pulse. The high power output is obtained by charging a large capacitor to build a large current flow without heavy drain from the external power source. The frequency is adjustable from 160 to 200 kilohertz (kHz) but is set at the factory for 200 kHz nominal. The higher the frequency, the shorter the wavelength, the sharper the resolution, the more accurate the depth sounding -- especially at relatively shallow depths where resolution to 0.1 foot increments is required.

RECEIVER

The gain of the receiver is controlled by an 8-bit microprocessor; i.e., a complete microcomputer. The algorithms and routines used by the microprocessor automatically compensate for boundary thermal layers, multiple bounces, listing, hull turbulence, and varying bottom conditions.

INITIALIZATION

When no power is applied, the LCD indicator is blank. When power is applied, the MK172 goes through an initializing routine that may take from a few seconds to as long as a half a minute to complete, depending on water depth when initializing is begun. During initialization, all LCD segments are displayed in the Built-in Test (BIT) mode while the microprocessor is determining bottom depth, and the LCD indicates 18.8. This display is an arbitrary number to indicate the LCD is functioning. When the true bottom depth is established, the LCD reverts to the display of that depth which replaces the BIT test mode pattern.

BOTTOM DEPTH TRACKING

Depth scaling is user selected by FT/M DIP switch. Bottom depth data are tracked via last-pulse logic and displayed in tenths of a foot resolution from three feet to 19.9 feet, then display continues in one-foot resolution from 20 feet to 199 feet.

If Feet mode is selected and the 199-foot depth measurement limit is exceeded, the error symbol 19E is displayed until a depth less than 199 feet is detected; then the depthsounder automatically resumes normal operation and display.

If the transducer emerges from the water due to severe listing or pitching, the last valid depth indication is displayed for five seconds; then the display begins to blink. Blinking indicates no valid data.

KEEL OFFSET

Displayed water depth is from keel to bottom. Keel depth, relative to the transducer, is established and set by the keel offset DIP switches. The keel offset is a one-time entry and is automatically read into the microprocessor when the MK172 system is powered up. Depth measured from the keel bottom provides a safety feature for when depth alarm setting has not been activated. The MK172 is shipped from the factory with the keel offset at "0".

ALARMS

The MK172 system has two depth alarms: a conventional down-looking alarm and a forward-looking trend alarm. When power is first applied, the alarms are inhibited (not enabled). Alarm functions are enabled or disabled (acknowledged) by momentarily pressing the ALARM pushbutton on the front panel. If "ALARM" arrow is on, the alarms are enabled.

DOWN-LOOKING ALARM

When the ALARM pushbutton is momentarily pressed the first time after power is applied, the LCD indicates a preset three-foot alarm depth, as measured from the transducer. To set alarm depth, press and hold ALARM switch until the MK172 completes the following event sequence:

- a. Indicator resets to zero, then
- b. Increments to 20 feet in 1-foot increments, then continues to increment as deep as 150 feet (if not stopped) in 5-foot increments.
- c. When desired alarm depth is indicated on LCD, for instance 35 feet, release ALARM pushbutton.
- d. LCD indicates alarm depth for three seconds, then reverts to real depth indication.
- e. Whenever real depth is equal to or less than the set alarm depth, ALARM signal sounds.

FORWARD-LOOKING ALARM

The microprocessor automatically computes the slope trend of the sea bottom while the vessel is underway. The forward looking alarm automatically sounds when the MK172 system senses the proximity of shoaling conditions approximately 20 seconds before the vessel would reach the shoal (run aground).

The forward-looking alarm function is based on a computation of a gradually rising bottom. The audible annunciator produces a 1/2-second beep rate until one of the three conditions is met:

1. A fixed depth is maintained
2. Boat moves into deeper water
3. ALARM pushbutton is momentarily depressed to acknowledge alarm condition.

SAILING WITH THE MK172 DEPTHSOUNDER SYSTEM

The MK172 Depthsounder System provides computerized alarm sensing that looks down and forward. The user selects and sets the alarm depth. The depthsounder monitors the changing bottom conditions ahead of the boat and automatically sounds 2.5 to 20 seconds prior to reaching that depth. If the boat is sailing in an area where the bottom is relatively smooth and is becoming shallower at a slow rate, a small safety margin (shallow alarm depth) can be set into the system. If the bottom could rise very quickly or has large rocks, a deeper alarm depth should be set so as to give adequate warning time. The prudent sailor should allow for the depth of the troughs between the waves as well as the time in the tide cycle.

The forward looking alarm does not actually look forward, but calculates the rate at which the water is getting shallower and determines when the water will be shallower than the set depth alarm based upon time. In effect, the forward-looking alarm tone tells the crew, "water is deep enough now, but at the rate depth is decreasing, the water depth will be less than the set alarm depth in 20 seconds". The forward looking alarm warns the sailor that the bottom is rising and provides a reasonable amount of time for changing course.

Although the forward looking alarm provides some additional safety measures under most conditions, the sailor must be aware of what it cannot do. It cannot predict a rock six feet high immersed in 10 feet of water and directly in front of the boat. It cannot predict the vertical or near vertical edge of a channel through which the boat is passing, or that 20 feet of water depth becomes only three feet of water depth in one boat length.

So while both down-looking and forward-alarms can be very useful, they should not be relied on as the only way to avoid shallow waters.

IV. PREVENTATIVE MAINTENANCE

Preventative maintenance is care and cleaning. The MK172 system contains two discrete major components: transducer with attached interconnect cable, and instrument/indicator.

TRANSDUCER

For proper system operation, the transducer must be completely "wetted" before use. Wetting requires from 24 to 48 hours of continuous immersion in water. Coating the sensor face of the transducer with liquid detergent before launching can shorten the wetting time.

Cleaning the transducer should be a periodic function. Local experience with bottom fouling can help the user determine the frequency of cleaning. To clean the transducer, scrub the sensor face and the area around the thru-hull fitting with a 3M Scrub Pad or 600 grit wet-dry sandpaper. If cleaning is done in a dry environment (transducer removed or boat out of water), wetting time must be allowed for accurate indications to be obtained. Other than occasional cleaning, the transducer requires no regular maintenance.

CAUTION
Do not paint the transducer face.

CABLING

If the LCD suddenly indicates zero, becomes erratic, or consistently presents a depth indication lower than known charted depth, the problem is usually in the cables or in the transducer location. Check power and transducer cable connections first; they should be tight. Inspect physical condition of cables. If they are aged and insulation is worn or damaged, they should be replaced. If the user has some means of checking the continuity of cable wiring; e.g., and Ohmmeter, the cables should be so checked while flexing the cables at intervals along the entire length. The cable area immediately next to the connectors may be especially vulnerable. Cables with broken or short-circuited wires must be replaced.

Cable routing should also be checked. Look for wear places that could damage insulation, and look for cable proximity to other electrical equipment that could allow pickup of electrical interference noise. Sources of noise generation could be engine ignition, radio transmitter, or other on-board electrical apparatus. If wear or abrasion points are in cable path, reroute cable. If sources of electrical noise generation are in cable path, reroute cable, or install an electrical noise suppressor in the cable line.

INSTRUMENT/INDICATOR

The instrument/indicator is a solid-state electronics assembly with no moving parts. It is designed to be virtually maintenance free. When not in use, its front panel should be covered with the Protective Cover (Signet P/N M0212-01). Periodically check the cable connections and clean the face of the display.

V. ACCESSORIES AND SPARE PARTS

Item	Description	Part #
1	Flush Depth Transducer	M17230
2	Protective Cover	M0212-01
3	Brass Depth Transducer	M27230

SIGNETMARINE
LIMITED TWO YEAR WARRANTY

SIGNETMarine's Limited Two Year Warranty warrants its instruments to be free from defect in material and workmanship under normal use two years from date of purchase by initial owner, or three years from date of manufacture, whichever is earlier. Products not purchased within three years from date of manufacture will not be covered by warranty. Proof of date of purchase is required to validate all warranty service.

Instruments which prove to be defective in the first year of the warranty period will be repaired or replaced free of charge including labor, F.O.B. our factory, or designated Service Centers (addresses furnished upon request). Transducers or cables are not covered after installation.

The limited warranty for the second year of the warranty period covers only non-moving parts, such as electrical components. Meter movements will not be covered after one year. All units qualifying for warranty repair after one year are subject to a service charge of \$20.00.

Items returned for warranty repair must be prepaid and insured for shipment. Warranty claims are processed on the condition that prompt notification of a defect is given to SIGNETMarine within the warranty period. SIGNETMarine shall have the sole right to determine whether in fact a warranty situation exists.

SIGNETMarine warranty does not cover travel time, mileage expenses, removal, reinstallation or calibration.

This warranty does not cover defects caused by installation, abuse, or electrical damage. SIGNETMarine will not warranty any instruments damaged during shipment to the factory which arrive either less the case or were improperly packed. Repair attempts by other than authorized Service Centers will void warranty.

SIGNETMarine is continually making design changes and improvements that adapt to original circuit configuration. These may be incorporated as required in older units on a minimal charge basis. Pre-authorization must be given by SIGNETMarine before any field upgrades are undertaken.

CONSEQUENTIAL DAMAGES

SIGNETMarine shall not be liable for special consequential damages of any nature with respect to any merchandise or service sold, rendered, or delivered.

This warranty gives you specific legal rights and you may also have other rights which vary from state to state.

APPENDIX 1

SPECIFICATIONS

PARAMETER	DESCRIPTION
BASIC	
Primary Application	Sailboat depthsounder
Nominal Range	200 feet (ft)
Minimum Depth	3 ft from transducer
Operation Frequency	Tunable from 155 to 200 kilohertz (kHz)
Pulses per second	6
Dimensions	
Instrument Housing	See Figure 1
Transducer	See Figure 2
Illumination	Back lighted with low-current light emitting diodes (LEDs)
Power Requirements	
Instrument	12 volts (V), 0.3 Ampere (A) average
Lighting	12 V, 0.02 A maximum
Connections	
Transducer	3-pin water resistant connector on shielded pigtail 12 to 18 inches (in) long. Signet P/N M07056
Power and Lights	
	4-conductor pigtail 12 to 18 in. long
	Red wire to +12V power
	Black wire to ground
	White wire to lights +
	Green wire to lights return
	Signet program number A1008 with type 8049 microprocessor (8-bit device)
	Signet MK172.3 Depthsounder Transducer
Firmware (program)	
Primary Sensor	
Environment	
Operating Temperature	32° to 160° F (0° to 71° C)
Storage Temperature	-20° to +180° F (-29° to 82° C)
Water Seal	Waterproof (submersible) front face, splashproof back face.
DISPLAY	
LCD Indicator	
Digit Height	Signet P/N M17260, transreflective, back lighted.
Number of Digits	0.7 inch
Automatic Range	2-1/2 (199 max.), left-hand zero suppression
	Less than 20 ft. indicates x.x. Greater than 20 ft. indicates xxx
	Retains last valid indication for 5 seconds (sec), then blinks
	Arrow displayed to left of digits when alarm is enabled.
Lost Return	
Visual Annunciators	

APPENDIX 2
TROUBLE SHOOTING CHART

APPENDIX 1
SPECIFICATIONS (CONT.)

PARAMETER	DESCRIPTION
ALARM	
Location	On rear cover
Loudness (SPL)	90 decibels at 1 foot
Enable	Momentarily press ALARM switch on front panel.
Alarm Depth Set	Increments by 1 ft to 20 ft, then by 5 ft beyond 20 ft. Maximum alarm depth setting is 150 ft.
Operation	
Downward	Beeper on when indication depth is equal to or less than alarm setting.
Forward-Looking	Computes predicted depth in the next 20-sec period. The alarm sound is a long beep tone.
Alarm Disable (Acknowledge)	Momentarily press ALARM switch to disable Alarm mode.
CONTROLS	
Keel Offset Switches	DIP switch pack on rear board assembly (rear cover panel must be removed to set switches). Three switches enable keel offset distance to be set from 0 to 7 ft in 1-ft increments.
Feet/Meters Switch	Inside; part of DIP switch pack (see keel offset). Position selects whether depth indication is feet or meters.
ALARM Switch	Pushbutton on front face; waterproof. Alarm mode on is activated on or off with each momentary depression. Holding down longer than 3 seconds resets alarm to 0. Continuous hold increments alarm set point. When in Meters mode, alarm set is displayed in meters.
POWER UP	ALARM mode disabled. Depth alarm setting 3 ft.

SYMPTOM	PROBABLE CAUSE	RECOMMENDED REMEDY
No display and/or display not back lighted.	12 VDC not connected 12 VDC connections reversed	Connect 12 VDC Correct 12 VDC connection; red to black, black to black.
	Open or short circuit in power cable.	Check power cable condition. Remove and replace defective power cable. If cable worn or abraded, reroute or replace cable.
Microprocessor does not complete all reset functions.	Power brought up too slowly. Unable to properly initialize.	Power on quickly by abrupt switching.
Display indication is flashing 18.8.8.	Transducer not connected. Open or short circuit in transducer cable.	Check and connect transducer cable. Check transducer cable condition. Remove and replace defective transducer cable. Do not splice or attempt cable repair because system impedance could be changed or shielding could be lost. Either impedance change or loss of shielding could adversely affect system performance.
	Cable abraded and wires short circuited to each other, or to shielding, or to some other ground (continuously or intermittently).	(See above.)
	Transducer covered with some fouling substance; e.g., oil, scum, algae, kelp-leaf, marine growths, etc.	Inspect and clean transducer.
Display indication random or erratic.	Electrical noise interference.	reroute transducer cable away from electrical source. Install electrical noise suppressor in series with 12VDC power.
Display in feet when should be in meters, or vice versa.	FT/M DIP switch not properly set before installation.	Check and set FT/M part of DIP switch pack to proper position.
Keel Offset not subtracted from indication or not correctly computed (discovered by comparing with chart or other boat).	Keel Offset DIP switches not properly set before installation.	Check and set Keel Offset part of DIP switch pack to proper position.

APPENDIX 2

TROUBLE SHOOTING CHART (CONT.)

SYMPTOM	PROBABLE CAUSE	RECOMMENDED REMEDY
Display indication continuously or intermittently wrong and/or audible annunciator producing wrong signals or no signals.	All above symptoms and causes corrected. Damaged or defective instruments/indicator electronics.	Return instrument/indicator component to nearest authorized dealer, or to factory.
Water inside instrument/indicator housing.	Crack or break in glass front cover or in housing.	Same as above.