

# 89260-060

## 5' PROTECTOR XSTREAM LABORATORY HOOD

NOMINAL WIDTH	TOTAL EXHAUST CFM & STATIC PRESSURE	100 FPM	S.P.	80 FPM	S.P.	60 FPM	S.P.
5 FEET	@ 18" SASH OPENING (62.5% OPEN)	580	0.12"	465	0.08"	350	0.05"
5 FEET	@ 28" SASH OPENING (100% OPEN)	930	0.32"	745	0.20"	560	0.12"

NOTE: SASH STOP INCLUDED AT 18" POSITION.

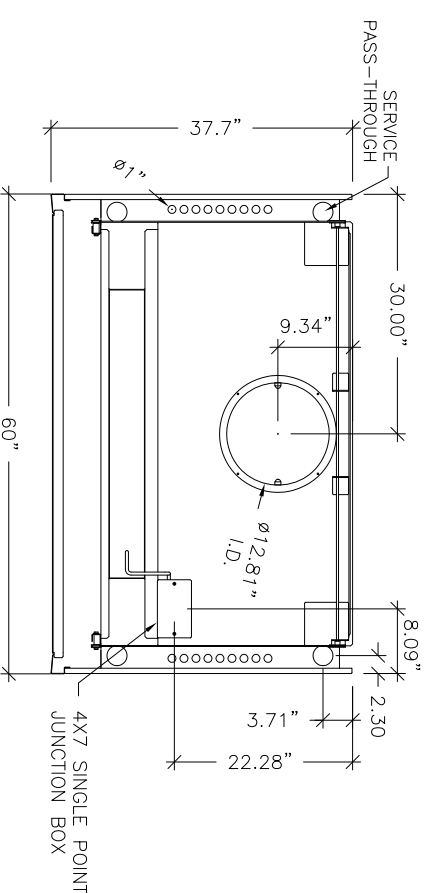

TOP VIEW

SCALE: 1/2" = 1'-0"

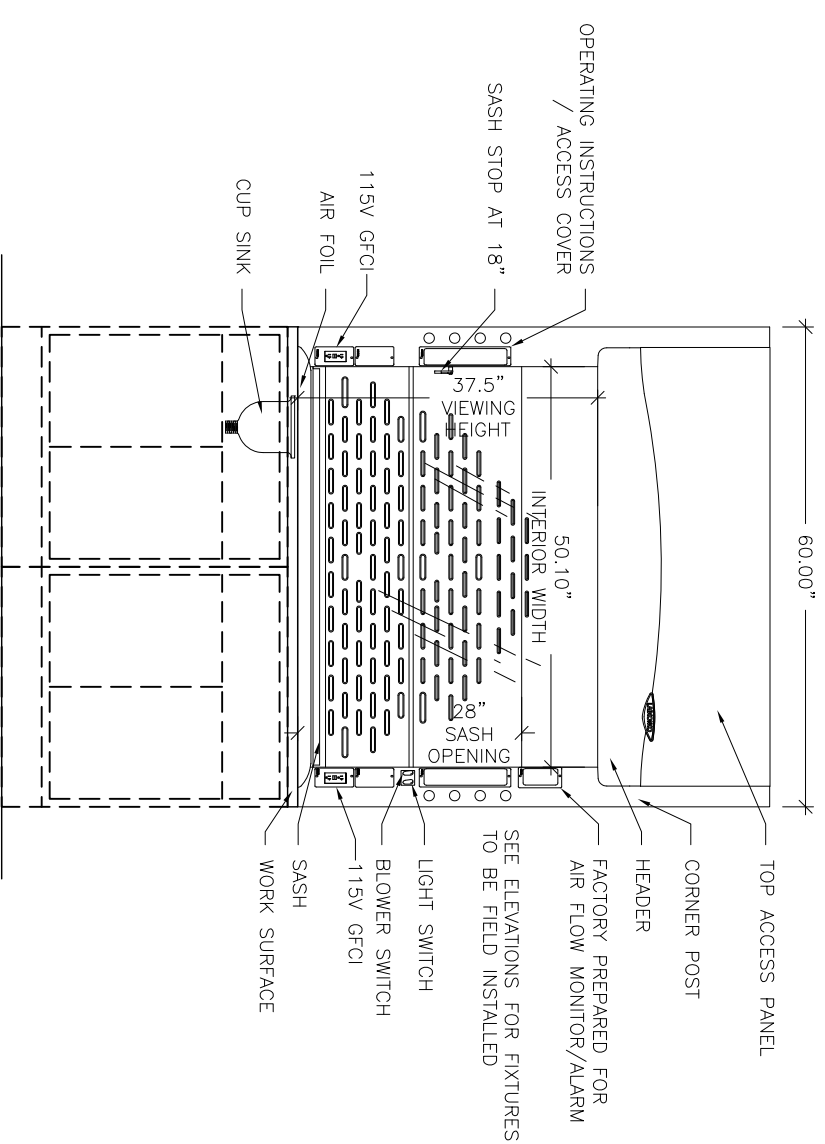

FRONT VIEW

SCALE: 1/2" = 1'-0"

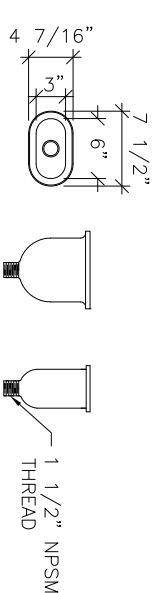

MATERIAL: POLYPROPYLENE  
COLOR: BLACK  
SEPARATE-REQUIRES  
INSTALLATION

CUP SINK  
SCALE: NTS

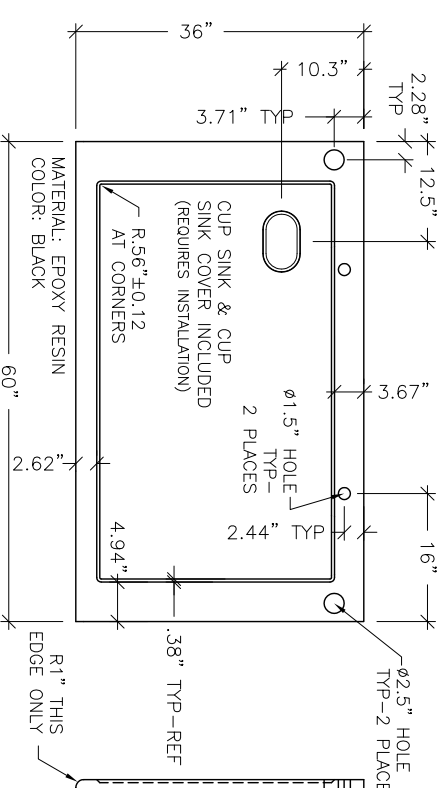

89260-076  
WORKSURFACE

SCALE: 1/2" = 1'-0"

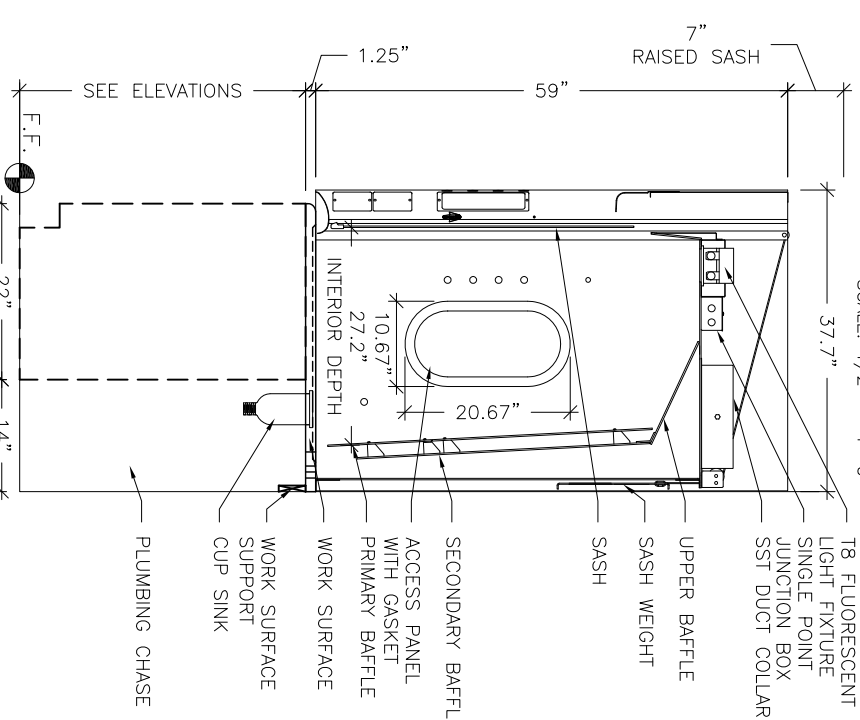

SIDE VIEW

SCALE: 1/2" = 1'-0"

## GENERAL DESCRIPTIONS

### EXTERIOR SUPERSTRUCTURE

DOUBLE WALL CONSTRUCTION  
18 GAUGE COLD ROLLED STEEL  
COLOR: GLACIER WHITE

### INTERIOR SUPERSTRUCTURE

GALVANIZED STEEL (STANDARD)

### LEFT / RIGHT FACIA

POWDER COATED STEEL  
COLOR: GLACIER WHITE

### LINER MATERIAL

MOLDED COMPOSITE SHEET

### SIDE PANELS

BOTH SIDES - REMOVABLE  
COLOR: GLACIER WHITE

### ELECTRICAL FIXTURES

FLUORESCENT LIGHT AND TUBES W/ SWITCH  
(2) 115V / 60HZ / 20A GFCI DUPLEXES  
ADDITIONAL ELECTRICAL FIXTURES ORDERED SEPARATELY  
TO BE INSTALLED AND WIRED BY OTHER

### WIRING

FUME HOOD WIRED AT FACTORY  
ELECTRICAL SERVICE CONNECTION MADE INSIDE 4X7  
JUNCTION BOX  
100-115V, 50/60HZ  
OVERLOAD RELAY THERMAL UNIT (P-HEATER) NOT  
PROVIDED WITH HOOD

### SASH

VERTICAL TRAVEL  
TEMPERED SAFETY GLASS  
COUNTER WEIGHTED AND BALANCED  
PULLEY SYSTEM  
SASH STOP @ 18"

### BAFFLES

MOLDED COMPOSITE SHEET

### INTERIOR ACCESS PANELS

RIGHT AND LEFT SIDES - GASKET PROVIDED

### CORNER POST WITH ACCESS COVERS

RIGHT AND LEFT SIDES  
18 GAUGE COLD ROLLED STEEL

### AIR FOIL

COLD ROLLED STEEL  
POWDER COAT FINISH

### EXHAUST CONNECTION

POWDER-COATED STAINLESS STEEL 12.81" ID

### WORKSURFACE

ORDERED SEPARATELY

### CUPSINK

INCLUDED WITH WORKSURFACE

### CABINETS

ORDERED SEPARATELY - SEE ELEVATION(S)

### REMOTE BLOWER

ORDERED SEPARATELY

### ALARM / MONITOR

ORDERED SEPARATELY AS REQUIRED

### PLUMBING

SERVICE FIXTURE KITS ORDERED SEPARATELY AS REQUIRED  
TO BE INSTALLED AND PLUMBED BY OTHER