



COMPLETE MONOGRAPH

2018 GROUP A PROPOSED CHANGES TO THE I-CODES COLUMBUS COMMITTEE ACTION HEARINGS

April 15–23, 2018
Columbus Convention Center
Columbus, Ohio

First Printing

Publication Date: February 2018

Copyright © 2018

By

International Code Council, Inc.

ALL RIGHTS RESERVED. This 2018-2019 Code Development Cycle, Group A (2018) Proposed Changes to the 2018 *International Codes* is a copyrighted work owned by the International Code Council, Inc. Without advanced written permission from the copyright owner, no part of this book may be reproduced, distributed, or transmitted in any form or by any means, including, without limitations, electronic, optical or mechanical means (by way of example and not limitation, photocopying, or recording by or in an information storage retrieval system). For information on permission to copy material exceeding fair use, please contact: Publications, 4051 West Flossmoor Road, Country Club Hills, IL 60478 (Phone 1-888-422-7233).

Trademarks: "International Code Council," the "International Code Council" logo are trademarks of the International Code Council, Inc.

PRINTED IN THE U.S.A.

TABLE OF CONTENTS (2018 Group A)

	PAGE
Introduction.....	ii
2018 – 2019 Code Groupings	ii
2018 ICC Committee Action Hearings	ii
Membership Councils to meet prior to the hearings.....	iii
Advanced Registration and Voting.....	iii
Assembly Action Process	iv
2018 Group A Code Development Committee Responsibilities	iv
Analysis Statements.....	iv
New Reference Standards.....	iv
Referenced Standards Updates.....	v
ICC Website.....	v
Proponent Contact Information	v
Hearing Order Changes and Tabling Proposals.....	vi
Floor Modifications.....	vi
Editorial Code Changes - Code Correlation Committee	viii
2018 – 2019 Code Development Schedule	ix
2018 – 2019 Staff Secretaries.....	xi
CP 28 Code Development	xii
Cross Index of Proposed Changes.....	xxxvi
Hearing Schedule	xlvi
2018 Proposed Changes (Table of Contents)	xlviii

INTRODUCTION

This 2018 Group A Cycle kicks off the second full cycle (2018 Group A and 2019 and Group B) which is utilizing the new cdpACCESS system. This system allows stakeholders to collaborate on potential code changes and to submit code changes online via the system.

As utilized during the 2015 and 2016 Cycles, code change modifications will be submitted and presented for committee and public viewing at the Committee Action Hearing through the cdpACCESS system. Detailed instructions for modifications will be available at the cdpACCESS website. In addition, printed instructions will be supplied at the CAH hearings. See page vi for details on the modification submittal process.

The proposed changes published herein have been submitted in accordance with established procedures [Council Policy 28 Code Development (CP 28)] (see page xxxvi) and are posted for review. The publication of these changes constitutes neither endorsement nor question of them but is in accordance with established procedures so that any interested individuals may make their views known to the relevant code committee and others similarly interested. In furtherance of this purpose, the committee will hold an open public hearing at the date and place shown below for the purpose of receiving comments and arguments for or against such proposed changes. Those who are interested in testifying on any of the published changes are expected to be represented at these hearings.

This compilation of code change proposals is available in electronic form only. ICC no longer prints and distributes this document. The compilation of code change proposals is posted on two locations on the ICC website: the customary posting which is linked from the [Code Development](#) webpage and from the [cdpACCESS](#) webpage.

2018 – 2019 CODE GROUPINGS

Codes to be considered in Group A Cycle:

- IBC – Egress
- IBC – Fire Safety
- IBC – General
- IFC
- IFGC
- IMC
- IPC
- IPMC
- IPSDC
- IRC – Mechanical
- IRC – Plumbing
- ISPSC
- IWUIC
- IZC

See page ix for the 2018 – 2019 ICC Code Development Schedule

2018 ICC COMMITTEE ACTION HEARINGS

These proposed changes will be discussed in public hearings to be held on April 15 – 23, 2018 at the Greater Columbus Convention Center, Columbus, OH. The code committees will conduct their public hearings in accordance with the schedule shown on page xlvi.

MEMBERSHIP COUNCILS TO MEET PRIOR TO THE HEARINGS

Prior to the hearings, some of the Membership Councils will be holding meetings during the Saturday, April 14th /Sunday morning, April 15th time period. This has been identified on the hearing schedule that was posted February 20th. Be sure to consult the [Membership Councils](#) webpage for details as they become available.

ADVANCED REGISTRATION AND VOTING

Assembly floor motions will be allowed following the committee action, however, the motion will be voted online following the hearings. All ICC members will be allowed to vote online on assembly floor motions. ICC members in attendance will still be allowed to vote on procedural “points of order” in accordance with Section 5.4.7 of CP 28 (see page xxii) **For identification purposes, all hearing participants must register. There is no cost to register or participate in the hearings.**

You are encouraged to advance register. [Click here](#) to register online.

The registration desk will be open in the lobby of the convention center according to the following schedule:

Sunday, April 15 th through Saturday, April 21 st	7:30 am to 5:00 pm
Sunday, April 22 nd	9:30 am to 12:00 pm
Monday, April 23 rd	7:30 am to 5:00 pm

CP 28 requires that ICC’s membership records regarding ICC members reflect the eligible voters 30 days prior to the start of the Committee Action Hearings. This process includes new members as well as changes to voting status. This applies to all ICC Members - Governmental Members and non Governmental Members. Applicable CP 28 sections noted below:

5.7.4 Eligible Online Assembly Motion Voters: All members of ICC shall be eligible to vote on online assembly floor motions. Each member is entitled to one vote, except that each Governmental Member Voting Representative may vote on behalf of its Governmental Member. Individuals who represent more than one Governmental Member shall be limited to a single vote. Application, whether new or updated, for ICC membership must be received by the Code Council 30 days prior to the first day of the Committee Action Hearing. The ballot period will not be extended beyond the published period except as approved by the ICC Board.

9.2 Applications: Applications for Governmental Membership must be received by the ICC at least 30 days prior to the Committee Action Hearing in order for its designated representatives to be eligible to vote at the Public Comment Hearing or Online Governmental Consensus Vote. Applications, whether new or updated, for Governmental Member Voting Representative status must be received by the Code Council 30 days prior to the commencement of the first day of the Public Comment Hearing in order for any designated representative to be eligible to vote. An individual designated as a Governmental Member Voting Representative shall provide sufficient information to establish eligibility as defined in the ICC Bylaws. The Executive Committee of the ICC Board, in its discretion, shall have the authority to address questions related to eligibility.

As such, new membership applications as well as renewal applications must be received by ICC’s Member Services Department by March 16, 2018. These records will be used to verify eligible voter status. Members are strongly encouraged to review their membership records for accuracy well in advance of the hearings so that any necessary changes are made prior to the March 16th deadline. For information on application for new membership and membership renewal, [click here](#) or call ICC Member Services at 1-888-ICC SAFE (422-7233)

ASSEMBLY ACTION PROCESS

Some important items to note regarding assembly consideration are:

- After the committee decision on a code change proposal is announced by the moderator, anyone in the assembly may make a floor motion for assembly action (5.7.1).
- After a floor motion for assembly action is made and seconded, the moderator will accept the motion and notify the attendees that the motion will be considered via an online voting process by all ICC members (5.7.2 and 5.7.4). No additional testimony will be permitted.
- Assembly floor motions will be voted on via an online process following the hearing (5.7.2).
- The online voting process will include the ability to view the video of the hearing testimony, committee deliberations and committee action (5.7.3). Each member, including Governmental Member Voting Representatives, gets only one vote (5.7.4). A successful assembly action requires a majority of votes cast and will result in an automatic public comment (5.7.5).
- A code change proposal that receives a successful assembly action will be placed on the Public Comment Agenda for individual consideration. The initial motion at the Public Comment Hearing will be the committee's action (7.4).

2018 GROUP A CODE DEVELOPMENT COMMITTEE RESPONSIBILITIES

Some sections of the International Codes have a letter designation in brackets in front of them. Code change proposals submitted for such code sections that have a bracketed letter designation in front of them will be heard by the respective committee responsible for such code sections. Because different committees will meet in different years, some proposals for a given code will be heard by a committee in a different year than the year in which the primary committee for this code meets.

For instance, Section 1505.10 of the IBC has a [BF] in front of it, meaning that this section is the responsibility of the IBC – Fire Safety Code Development Committee. However, the technical content of Chapter 15 is generally structural and as such, code change proposals are designated with the structural designation: IBC – S. In this current 2018 Group A Cycle, there are 13 such IBC – S proposals, to be heard by either the IBC – Fire Safety, IBC – General, or the IPC Code Development Committee. Be sure to consult the Cross Index of Proposed Code Changes on page xxxvi and the respective Tentative Order of Discussion for the individual committees.

A complete summary of the 2018 – 2019 Group A and Group B Code Development Committees' responsibilities can be viewed at the [ICC Website](#).

ANALYSIS STATEMENTS

Various proposed changes published herein contain an "analysis" that appears after the proponent's reason. These comments do not advocate action by the code committees or the voting membership for or against a proposal. The purpose of such comments is to identify pertinent information that is relevant to the consideration of the proposed change by all interested parties, including those testifying, the code committees and the voting membership. Staff analyses customarily identify such things as: conflicts and duplication within a proposed change and with other proposed changes and/or current code text; deficiencies in proposed text and/or substantiation; text problems such as wording defects and vagueness; background information on the development of current text; and staff's review of proposed reference standards for compliance with the Procedures. Lack of an analysis indicates neither support for, nor opposition to a proposal.

NEW REFERENCE STANDARDS

Proposed changes that include the addition of a reference to a new standard (a standard that is not currently referenced in the current edition of the I-Codes) will include in the proposal the number, title and edition of the proposed standard. This identifies to all interested parties the precise document that is being proposed and which would be included in the referenced standards chapter of the code if the proposed change is approved. Section 3.6.3.1 of CP 28 requires that a code change proposal will not be processed unless a consensus draft of the standard has been provided. Proponents of code changes which propose a new standard have been directed to provide copies of the standard to the code

development committee. An analysis statement will be posted on the ICC website providing information regarding standard content, such as enforceable language, references to proprietary products or services, and references to consensus procedure. The analysis statements for referenced standards will be posted on or before April 2, 2018. This information will also be published and made available at the hearings.

Proposed new reference standards must be completed and readily available prior to the 2018 Public Comment Hearing in accordance with Section 3.6.3.1 of CP28.

REFERENCED STANDARDS UPDATES

Updates to currently referenced standards in any of the 2018 Codes will be considered by the Administrative Code Development Committee in the 2019 Group B Cycle.

Note that based on recent changes to Section 3.6.3.1 of CP28, updates to existing referenced standards that are part of a code change proposal that includes technical revisions to code text to coordinate with such proposed standard(s) update are to be processed as proposed new standards in accordance with Sections 3.4 and 3.6.3.1.2 of CP28. Accordingly, drafts of the revisions would have needed to be supplied at the time of the code change submittal and the standard update will be required to be completed and published on or before the Public Comment Hearing for this 2018 Cycle, October 24, 2018.

It should be noted that, in accordance with Section 4.6 of CP 28, standards promulgators will have until December 1, 2020 to finalize and publish any updates to standards in the administrative update. If the standard update is not finalized and published by December 1, 2020, the respective I-Codes will be revised to reference the previously listed year edition of the standard.

ICC WEBSITE

This document is posted on the [ICC Website](#). While great care has been exercised in the publication of this document, errata to proposed changes may occur. Errata, if any, will be identified in updates posted prior to the Committee Action Hearing. Users are encouraged to periodically review the [ICC Website](#). Additionally, analysis statements for code changes which propose a new referenced standard will be updated and posted to reflect the staff review of the standard for compliance with Section 3.6 of the Procedures.

PROPONENT CONTACT INFORMATION

In accordance with procedures, proponents are under no obligation to provide an email address for their posted proposal. For most of the code change proposals, an email address for the proponent has been provided. In an effort to continue to provide for proponent's privacy and at the same time allow an initial contact between an interested party and the proponent, new to this 2018 Cycle we will be utilizing cdpACCESS to allow an interested party to initiate contact with the proponent without identifying the proponent's email address. The process is follows:

- Interested party logs into cdpACCESS and searches for the subject code change.
- Interested party locates the button "Contact the Proponent" to request that cdpACCESS contact the proponent, providing the interested party's name and email address.
- cdpACCESS uses the proponent email address on file and sends a notification to the proponent indicating the name of the interested party and their email address and that the interested party would like to discuss the code change.
- The interested party receives an email noting that the cdpACCESS system has sent the request to the proponent.
- It is up to the proponent to determine if they would like to respond and contact the interested party.
- The proponent is under no obligation to respond to the cdpACCESS request for contact or to contact the interested party. The proponent's contact information is not revealed to the interested party as part of this initial contact.

Screen shots for the process noted above are under development and will be posted on the [ICC website](#).

HEARING ORDER CHANGES AND TABLING OF PROPOSALS

The Code Change Agenda that places the code change proposals in a logical order for each hearing committee is shown at the beginning of the respective committee's group of code change proposals. In accordance with Section 5.4.4 of CP28, any attendee at the hearing is allowed make a motion to revise the hearing order at any time during the hearings except while a code change is being discussed, but usually as the first order of business at the hearing. Preference is given to grouping like subjects together, and moving items back to a later position on the agenda.

This motion is considered in order unless the proponent(s) of the moved code change proposals are in attendance and object to the move. If there is objection to the move, the motion is ruled out of order by the Moderator. This ruling is final and not debatable. If the motion is not ruled out of order, the motion is subject to a 2/3 vote of those present.

New for these hearings, a motion to table a code change proposal is allowed in accordance with Section 5.4.5 of CP28. Just as with a motion to move a code change proposal in the hearing order, this motion is in order only if there is no objection from the proponent(s) in attendance at the hearing. When the proponent(s) object, the motion to table is ruled out of order by the Moderator. The ruling is final and not subject to debate. The motion to table must identify the location to where the code change proposal consideration will be resumed by either identifying a specific date and time within the timeframe of the Code Change Agenda for the group of code change proposals under consideration or by designating a specific location in the Code Change Agenda.

FLOOR MODIFICATIONS

With the implementation of the new cdpACCESS online system, CP 28 was revised to reflect that floor modifications would be submitted electronically at the Committee Action Hearing (CAH).

The only aspect of the modification process that has changed is the way the modification is submitted and viewed. It is required to be submitted electronically via cdpACCESS. All other aspects of the modification process are unchanged. As in the past, the proponent of the modification must be in attendance at the CAH to present the modification as part of his/her testimony.

Those who are submitting a modification for consideration by the respective Code Development Committee are required to sign a Copyright Release in order to have their modification(s) considered (Section 3.3.5.5 of CP 28). This feature is built into cdpACCESS similar to the way the release is executed for code change and public comment submittals.

The Chair rules the modification in or out of order. Note that this is a procedural ruling to determine if the modification is to be permitted to be considered at the hearing. It is not a technical ruling. The ruling is final, with no challenge allowed.

The modification proponent is required to identify the specific text of the code change proposal that is being revised and the revision itself. In this way, it is very similar to the public comment process and that is the way cdpACCESS was developed to process modifications.

Example:

Original code change proposal.

The original code change proposal requested the following change to Section 305.3 of the IPMC: (Note that the example is fictional.)

**PM10-18
305.13**

Proponent: John West representing self

Revise as follows:

305.3 Interior surfaces. All interior surfaces, including windows and doors, shall be maintained in good and clean condition. Peeling, chipping, flaking or abraded paint shall be repaired, removed or covered. Cracked or loose plaster, ~~decayed wood~~ and other defective surface conditions shall be corrected. Surfaces of porous materials made of or containing organic materials, such as but not limited to wood, textiles, paint, cellulose insulation, and paper, including paper-faced gypsum board, that have visible signs of mold or mildew shall be removed and replaced or remediated in an approved manner.

Exception: Porous materials that do not contain organic materials, such as clean unpainted bricks and concrete.

Proposed modification:

A modification to the code change proposal is proposed:

1. To add “and sanitary” after “clean” in the first sentence.
2. To add “or water permeable” after “porous” in the third sentence.
3. Delete “in an approved manner.” in the last sentence.
4. Delete the proposed new exception.

The cdpACCESS system will provide the text of the original code change proposal with the proposed change incorporated into the text. Using the cdpACCESS system, the proponent of the modification locates the original change in the system.

The proponent of the modification will need to manually install strikethrough (ex:” ~~delete~~) and underline (ex: add) formatting showing the additional revisions to the original proposal.

cdpACCESS will show the modification as follows:

**PM10-13
305.13**

Modification Proponent: Sam Sumter representing self

Modify the proposal as follows:

305.3 Interior surfaces. All interior surfaces, including windows and doors, shall be maintained in good, ~~and~~ clean and sanitary condition. Peeling, chipping, flaking or abraded paint shall be repaired, removed or covered. Cracked or loose plaster and other defective surface conditions shall be corrected. Surfaces of porous or water permeable materials made of or containing organic materials, such as but not limited to wood, textiles, paint, cellulose insulation, and paper, including paper-faced gypsum board, that have visible signs of mold or mildew shall be removed and replaced or remediated ~~in an approved manner.~~

~~Exception:~~ ~~Porous materials that do not contain organic materials, such as clean unpainted bricks and concrete.~~

Among the benefits of using cdpACCESS to submit modifications are:

- Modification proponents will be able to access the system in advance of the hearings to develop their modification (see “Detailed Steps of the Modification Submission Process via cdpACCESS” on the following pages).
- The collaboration features will allow modification proponents to collaborate before submitting.
- 20 hard copies of the modification for distribution to the committee are no longer required.
- You can preview your modification at any time by downloading a pdf via cdpACCESS.

OVERVIEW OF THE MODIFICATION PROCESS (see CP28 Section 5.5.2 on page xxiii)

1. **NEW.** Modification submitted electronically via cdpACCESS. As in the past, this submittal is required well in advance of the code change proposal being brought to the floor.

2. The code change proposal is brought to the floor by the Moderator.

IMPORTANT NOTE: ONCE A CODE CHANGE PROPOSAL IS BROUGHT TO THE FLOOR, ALL MODIFICATIONS MUST BE IN THE cdpACCESS SYSTEM. SEE NOTE 1.

3. Modification proponent suggests the modification from the floor at the hearing.

4. **NEW.** Modification posted to cdpACCESS for public viewing (including the hearing room via WiFi) and committee viewing.

5. Modification displayed on the screen in the hearing room.

6. Chair rules the modification in or out of order.

7. If ruled in order, testimony on the modification is initiated.

EDITORIAL CODE CHANGES - CODE CORRELATION COMMITTEE

In a typical code change cycle, there are code change proposals that are considered strictly editorial. Section 4.4 of CP 28 (see below) establishes a process by which the Code Correlation Committee (CCC) considers such proposals.

4.4 Editorial Code Change Proposals. When a code change proposal is submitted that proposes an editorial or format change that, in the opinion of the Secretariat, does not affect the scope or application of the code, the proposal shall be submitted to the Code Correlation Committee who shall deem the code change proposal as editorial or send the proposal back to the Secretariat to be considered by the appropriate code development committee. To be deemed editorial, such proposal shall require a majority vote of the Code Correlation Committee. Editorial proposals shall be published in the Code Change Agenda. Such proposals shall be added to the hearing agenda for consideration by the appropriate code development committee upon written request to ICC by any individual. The deadline to submit such requests shall be 14 days prior to the first day of the Committee Action Hearing. Code Correlation Committee proposals that are not added to a code development committee hearing agenda shall be published in the next edition of the code with no further consideration.

There are 7 such proposals in the current 2018 Cycle. They are both proposals to the IEBC and are posted as the first code changes in the IEBC's agenda. They are identified by code change numbers CCC1 through CCC7.

As noted in Section 4.4, anyone may request that either of these proposals be added to the hearing agenda. The deadline to make such a request is 11: 59 pm Pacific on Sunday, April 1, 2018 via email. Be sure to identify the code change number noted above. Such requests must be sent to:

Dave Bowman
Manager, Codes
dbowman@iccsafe.org

2018/2019 ICC CODE DEVELOPMENT SCHEDULE

(February 10, 2017)

STEP IN CODE DEVELOPMENT CYCLE	DATE	
	2018 – Group A Codes IBC- E, IBC - FS, IBC -G, IFC, IFGC, IMC, IPC, IPMC, IPSDC, IRC – M, IRC- P, ISPSC, IWUIC, IZC	2019 – Group B Codes Admin, IBC-S, IEBC, IECC-C, IECC-R/IRC-E, IgCC (Ch. 1), IRC – B
2018 EDITION OF I-CODES PUBLISHED	Fall/2017 (except 2018 IgCC, see Group B Codes on page x)	
DEADLINE FOR RECEIPT OF APPLICATIONS FOR ALL CODE COMMITTEES	June 1, 2017 for the 2018/2019 Cycle. Call for committee posted in February /2017.	
DEADLINE FOR cdpACCESS ONLINE RECEIPT OF CODE CHANGE PROPOSALS	January 8, 2018 (Extended to January 11, 2018)	January 7, 2019
WEB POSTING OF “PROPOSED CHANGES TO THE I-CODES”	February 28, 2018 [*]	March 4, 2019 [*]
COMMITTEE ACTION HEARING (CAH)	April 15 – 23, 2018 Greater Columbus Convention Center Columbus, OH	April 28 – May 8, 2019 Albuquerque Convention Center Albuquerque, NM
ONLINE CAH ASSEMBLY FLOOR MOTION VOTE	Starts approx. two weeks after last day of the CAH. Open for 2 weeks.	Starts approx. two weeks after last day of the CAH. Open for 2 weeks.
WEB POSTING OF “REPORT OF THE COMMITTEE ACTION HEARING”	May 30, 2018	June 11, 2019
DEADLINE FOR cdpACCESS ONLINE RECEIPT OF PUBLIC COMMENTS	July 16, 2018	July 24, 2019
WEB POSTING OF “PUBLIC COMMENT AGENDA”	August 31, 2018 [*]	September 4, 2019 [*]
PUBLIC COMMENT HEARING (PCH) ANNUAL CONFERENCE DATES NOTED BY AC	October 24 – 31, 2018 Greater Richmond Convention Center Richmond, VA AC: October 21 – 23	October 23 – 30, 2019 Clark County, NV AC: October 20 - 22
ONLINE GOVERNMENTAL CONSENSUS VOTE (OGCV)	Starts approx. two weeks after last day of the PCH. Open for 2 weeks.	Starts approx. two weeks after last day of the PCH. Open for 2 weeks.
WEB POSTING OF FINAL ACTION	Following Validation Committee certification of OGCV and ICC Board confirmation.	Following Validation Committee certification of OGCV and ICC Board confirmation.

^{*} Web posting of the “Proposed Changes to the I-Codes” and “Public Comment Agenda” will be posted no later than scheduled. ICC will make every effort to post these documents earlier, subject to code change/public comment volume and processing time.

2018 Group A Codes/Code committees:

- IBC-E: IBC Egress provisions. Chapters 10 and 11.
- IBC-FS: IBC Fire Safety provisions. Chapters 7, 8, 9 (partial), 14 and 26. Majority of IBC Chapter 9 is maintained by the IFC. See notes.
- IBC-G: IBC General provisions. Chapters 3 – 6, 12, 13, 27 – 33.
- IFC: The majority of IFC Chapter 10 is maintained by IBC-E. See notes.
- IFGC
- IMC
- IPC
- IPMC (code changes heard by the IPM/ZC (IPMC & IZC) code committee)
- IPSDC (code changes heard by the IPC code committee)
- IRC-M: IRC Mechanical provisions. Chapters 12 – 23 (code changes heard by the IRC - MP code committee)
- IRC-P: IRC Plumbing provisions. Chapters 25 – 33 (code changes heard by the IRC - MP code committee)
- ISPSC
- IWUIC (code changes heard by the IFC code committee)
- IZC (code changes heard by the IPM/ZC (IPMC & IZC) code committee)

2019 Group B Codes/Code committees:

- Admin: Chapter 1 of all the I-Codes except the IECC, IgCC and IRC. Also includes the update of currently referenced standards in all of the 2018 Codes, except the IgCC.
- IBC-S: IBC Structural provisions. IBC Chapters 15 – 25 and IEBC structural provisions. See notes.
- IEBC: IEBC Non-structural provisions. See notes.
- IECC-C: IECC Commercial energy provisions.
- IECC-R/IRC-E: IECC Residential energy provisions and IRC Energy provisions in Chapter 11.
- IgCC: Chapter 1 of the IgCC. Remainder of the code is based on the provisions of ASHRAE Standard 189.1 *Standard for the Design of High-Performance Green Buildings, Except Low-Rise Residential Buildings*. The 2018 IgCC is scheduled to be published in the Summer/2018.
- IRC-B: IRC Building provisions. Chapters 1 – 10.

A 2020 Group C cycle is not scheduled.

Notes:

- Be sure to review the document entitled “2018/2019 Code Committee Responsibilities” which will be posted. This identifies responsibilities which are different than Group A and B codes and committees which may impact the applicable code change cycle and resulting code change deadline. As an example, throughout Chapter 9 of the IBC (IBC- Fire Safety), there are numerous sections which include the designation “[F]” which indicates that the provisions of the section are maintained by the IFC code committee. Similarly, there are numerous sections in the IEBC which include the designation “[BS]”. These are structural provisions which will be heard by the IBC – Structural committee. The designations in the code are identified in the Code Committee Responsibilities document.
- I-Code Chapter 1: Proposed changes to the provisions in Chapter 1 of the majority of the I-Codes are heard in Group B (see Admin above for exceptions). Be sure to review the brackets ([]) of the applicable code.
- Definitions. Be sure to review the brackets ([]) in Chapter 2 of the applicable code and the Code Committee Responsibilities document to determine which code committee will consider proposed changes to the definitions.
- Proposed changes to the ICC Performance Code will be heard by the code committee noted in brackets ([]) in the section of the code and in the Code Committee Responsibilities document

2018 - 2019 STAFF SECRETARIES

GROUP A (2018)

IBC – Egress Chapters 10, 11	IBC – Fire Safety Chapters 7, 8, 9, 14, 26	IBC – General Chapters 1-6, 12, 13, 27-34	IFC	IFGC
Kim Paarlberg Indianapolis, IN Ext 4306 kpearlberg@iccsafe.org	Michelle Britt Chicago Regional Office Ext 4284 mbritt@iccsafe.org Kermit Robinson Western Regional Office Ext 3317 krobinson@iccsafe.org	Kermit Robinson Western Regional Office Ext 3317 krobinson@iccsafe.org Allan Bilka Central Regional Office Ext 4326 abilka@iccsafe.org	Beth Tubbs Northbridge, MA Ext 7708 btubbs@iccsafe.org Keith Enstrom Chicago Regional Office Ext 4342 kenstrom@iccsafe.org	Gregg Gress Chicago Regional Office Ext 4343 ggress@iccsafe.org
IMC	IPC/IPSDC	ICC Performance	IPMC	IRC Mechanical
Gregg Gress Chicago Regional Office Ext 4343 ggress@iccsafe.org	Fred Grable Chicago Regional Office Ext 4359 fgrable@iccsafe.org	Beth Tubbs Northbridge, MA Ext 7708 btubbs@iccsafe.org	Ed Wirtschoreck Chicago Regional Office Ext 4317 ewirtschoreck@iccsafe.org	Gregg Gress Chicago Regional Office Ext 4343 ggress@iccsafe.org
IRC Plumbing	ISPSC	IZC		
Fred Grable Chicago Regional Office Ext 4359 fgrable@iccsafe.org	Fred Grable Chicago Regional Office Ext 4359 fgrable@iccsafe.org	Ed Wirtschoreck Chicago Regional Office Ext 4317 ewirtschoreck@iccsafe.org		

GROUP B (2019)

ADMINISTRATIVE Chapter 1 All Codes IRC	IBC- Structural Chapters 15- 25 IEBC Structural	IECC-Commercial Commercial Chapters C1- C5	IECC/IRC – Residential IECC Residential Chapters R1 – R5, IRC Chapter 11	IEBC
Kim Paarlberg Indianapolis, IN Ext 4306 kpearlberg@iccsafe.org	Ed Wirtschoreck Chicago Regional Office Ext 4317 ewirtschoreck@iccsafe.org	Michelle Britt Chicago Regional Office Ext 4284 mbritt@iccsafe.org	Michelle Britt Chicago Regional Office Ext 4287 mbritt@iccsafe.org	Beth Tubbs Northbridge, MA Ext 7708 btubbs@iccsafe.org Keith Enstrom Chicago Regional Office Ext 4342 kenstrom@iccsafe.org
ICC Performance	IRC-Building	IWUIC		
Beth Tubbs Northbridge, MA Ext 7708 btubbs@iccsafe.org	Allan Bilka Central Regional Office Ext 4326 abilka@iccsafe.org Kim Paarlberg Indianapolis, IN Ext 4306 kpearlberg@iccsafe.org	Keith Enstrom Chicago Regional Office Ext 4342 kenstrom@iccsafe.org		



CP #28-05 CODE DEVELOPMENT

Approved: 9/24/05
Revised: 12/08/17

1.0 Introduction

- 1.1 **Purpose of Council Policy:** The purpose of this Council Policy is to prescribe the Rules of Procedure utilized in the continued development and maintenance of the International Codes (Codes).
- 1.2 **Objectives:** The ICC Code Development Process has the following objectives:
 - 1.2.1 The timely evaluation and recognition of technological developments pertaining to construction regulations.
 - 1.2.2 The open discussion of code change proposals by all parties desiring to participate.
 - 1.2.3 The final determination of Code text by public officials actively engaged in the administration, formulation or enforcement of laws, ordinances, rules or regulations relating to the public health, safety and welfare and by honorary members.
 - 1.2.4 The increased participation of all parties desiring to participate through an online submittal and voting process that includes opportunities for online collaboration.
- 1.3 **Code Publication:** The ICC Board of Directors (ICC Board) shall determine the title and the general purpose and scope of each Code published by the ICC.
 - 1.3.1 **Code Correlation:** The provisions of all Codes shall be consistent with one another so that conflicts between the Codes do not occur. A Code Scoping Coordination Matrix shall determine which Code shall be the primary document, and therefore which code development committee shall be responsible for maintenance of the code text where a given subject matter or code text could appear in more than one Code. The Code Scoping Coordination Matrix shall be administered by the Code Correlation Committee as approved by the ICC Board. Duplication of content or text between Codes shall be limited to the minimum extent necessary for practical usability of the Codes, as determined in accordance with Section 4.5.
- 1.4 **Process Maintenance:** The review and maintenance of the Code Development Process and these Rules of Procedure shall be by the ICC Board. The manner in which Codes are developed embodies core principles of the organization. One of those principles is that the final content of the Codes is determined by a majority vote of the governmental and honorary members. It is the policy of the ICC Board that there shall be no change to this principle without the affirmation of two-thirds of the governmental and honorary members responding.

- 1.5 Secretariat:** The Chief Executive Officer shall assign a Secretariat for each of the Codes. All correspondence relating to code change proposals and public comments shall be addressed to the Secretariat. The Secretariat shall have the authority to facilitate unforeseen situations which arise in the implementation of this council policy. Staff shall maintain a record of such actions.
- 1.6 Recording:** Individuals requesting permission to record any meeting or hearing, or portion thereof, shall be required to provide the ICC with a release of responsibility disclaimer and shall acknowledge that ICC shall retain sole ownership of the recording, and that they have insurance coverage for liability and misuse of recording materials. Equipment and the process used to record shall, in the judgment of the ICC Secretariat, be conducted in a manner that is not disruptive to the meeting. The ICC shall not be responsible for equipment, personnel or any other provision necessary to accomplish the recording. An unedited copy of the recording shall be forwarded to ICC within 30 days of the meeting. Recordings shall not otherwise be copied, reproduced or distributed in any manner. Recordings shall be returned to ICC or destroyed upon the request of ICC.

2.0 Code Development Cycle

- 2.1 Intent:** The code development cycle shall consist of the complete consideration of code change proposals in accordance with the procedures herein specified, commencing with the deadline for submission of code change proposals (see Section 3.5) and ending with publication of the Final Action on the code change proposals (see Section 10.4).
- 2.2 New Editions:** The ICC Board shall determine the schedule for publishing new editions of the Codes. Each new edition shall incorporate the results of the code development activity since the previous edition.
- 2.3 Supplements:** The results of code development activity between editions may be published.
- 2.4 Emergency Action Procedures:**
- 2.4.1 Scope:** Emergency actions are limited to those issues representing an immediate threat to health and safety that warrant a more timely response than allowed by the Code Development Process schedule.
- 2.4.2 Initial Request:** A request for an emergency action shall be based upon perceived threats to health and safety and shall be reviewed by the Codes and Standards Council for referral to the ICC Board for action with their analysis and recommendation.
- 2.4.3 Board and Member Action:** In the event that the ICC Board determines that an emergency amendment to any Code or supplement thereto is warranted, the same may be adopted by the ICC Board. Such action shall require an affirmative vote of at least two-thirds of the ICC Board.

The ICC membership shall be notified within ten days after the ICC Boards' official action of any emergency amendment. At the next Annual Business Meeting, any emergency amendment shall be presented to the members for ratification by a majority of the Governmental Member Voting Representatives and Honorary Members present and voting.

All code revisions pursuant to these emergency procedures and the

reasons for such corrective action shall be published as soon as practicable after ICC Board action. Such revisions shall be identified as an emergency amendment.

Emergency amendments to any Code shall not be considered as a retro-active requirement to the Code. Incorporation of the emergency amendment into the adopted Code shall be subjected to the process established by the adopting authority.

2.5 Code Development Record. The code development record shall include the official documents and records developed in support of the given code development cycle. This includes the following:

1. Code Change Agenda (Section 4.8)
2. Audio and video recording of the Committee Action Hearing (Section 5.1)
3. The Online Assembly Floor Motion Ballot (Section 5.7.3)
4. Report of the Committee Action Hearing (Section 5.8)
5. Public Comment Agenda (Section 6.6)
6. Public Comment Hearing results (Section 7.5.8.10)
7. Audio and video recording of the Public Comment Hearing (Section 7.1)
8. The Online Governmental Consensus Ballot (Section 8.2)
9. Final Action results (Section 10.4)
10. Errata to the documents noted above

The information resulting from online collaboration between interested parties shall not be part of the code development record.

3.0 Submittal of Code Change Proposals

3.1 Intent: Any interested person, persons or group may submit a code change proposal which will be duly considered when in conformance to these Rules of Procedure.

3.2 Withdrawal of Proposal: A code change proposal may be withdrawn by the proponent (WP) at any time prior to membership action on the consent agenda at the Public Comment Hearing or prior to testimony on the code change proposal on the individual consideration agenda at the Public Comment Hearing. All actions on the code change proposal shall cease immediately upon the withdrawal of the code change proposal.

3.3 Form and Content of Code Change Submittals: Each code change proposal shall be submitted separately and shall be complete in itself. Each submittal shall contain the following information:

3.3.1 Proponent: Each code change proposal shall include the name, title, mailing address, telephone number, and email address of the proponent. Email addresses shall be published with the code change proposals unless the proponent otherwise requests on the submittal form.

3.3.1.1 If a group, organization or committee submits a code change proposal, an individual with prime responsibility shall be indicated.

3.3.1.2 If a proponent submits a code change proposal on behalf of a client, group, organization or committee, the name and mailing address of the client, group, organization or committee shall be indicated.

- 3.3.2 Code Reference:** Each code change proposal shall relate to the applicable code sections(s) in the latest edition of the Code.
- 3.3.2.1** If more than one section in the Code is affected by a code change proposal, appropriate proposals shall be included for all such affected sections.
 - 3.3.2.2** If more than one Code is affected by a code change proposal, appropriate proposals shall be included for all such affected Codes and appropriate cross referencing shall be included in the supporting information.
- 3.3.3 Multiple Code Change Proposals to a Code Section.** A proponent shall not submit multiple code change proposals to the same code section. When a proponent submits multiple code change proposals to the same section, the proposals shall be considered as incomplete proposals and processed in accordance with Section 4.3. This restriction shall not apply to code change proposals that attempt to address differing subject matter within a code section.
- 3.3.4 Text Presentation:** The text of the code change proposal shall be presented in the specific wording desired with deletions shown struck out with a single line and additions shown underlined with a single line.
- 3.3.4.1** A charging statement shall indicate the referenced code section(s) and whether the code change proposal is intended to be an addition, a deletion or a revision to existing Code text.
 - 3.3.4.2** Whenever practical, the existing wording of the text shall be preserved with only such deletions and additions as necessary to accomplish the desired change.
 - 3.3.4.3** Each code change proposal shall be in proper code format and terminology.
 - 3.3.4.4** Each code change proposal shall be complete and specific in the text to eliminate unnecessary confusion or misinterpretation.
 - 3.3.4.5** The proposed text shall be in mandatory terms.
- 3.3.5 Supporting Information:** Each code change proposal shall include sufficient supporting information to indicate how the code change proposal is intended to affect the intent and application of the Code.
- 3.3.5.1 Purpose:** The proponent shall clearly state the purpose of the code change proposal (e.g. clarify the Code; revise outdated material; substitute new or revised material for current provisions of the Code; add new requirements to the Code; delete current requirements, etc.)
 - 3.3.5.2 Reasons:** The proponent shall justify changing the current Code provisions, stating why the code change proposal is superior to the current provisions of the Code. Code change proposals which add or delete requirements shall be supported by a logical explanation which clearly shows why the current Code provisions are inadequate or overly restrictive, specifies the shortcomings of the current Code provisions and explains how such code change proposals will improve the Code.
 - 3.3.5.3 Substantiation:** The proponent shall substantiate the code change proposal based on technical information and

substantiation. Substantiation provided which is reviewed in accordance with Section 4.2 and determined as not germane to the technical issues addressed in the code change proposal may be identified as such. The proponent shall be notified that the code change proposal is considered an incomplete proposal in accordance with Section 4.3 and the proposal shall be held until the deficiencies are corrected. The proponent shall have the right to appeal this action in accordance with the policy of the ICC Board. The burden of providing substantiating material lies with the proponent of the code change proposal. Supporting documentation may be provided via a link to a website provided by the proponent and included in the reason statement. The reason statement shall include the date the link was created. All substantiating material published by ICC is material that has been provided by the proponent and in so publishing ICC makes no representations or warranties about its quality or accuracy.

3.3.5.4 Bibliography: The proponent shall submit a bibliography of any substantiating material submitted with the code change proposal. The bibliography shall be published with the code change proposal and the proponent shall make the substantiating materials available for review at the appropriate ICC office and during the public hearing. Supporting documentation may be provided via a link to a website provided by the proponent and included in the bibliography. The reason statement shall include the date the link was created.

3.3.5.5 Copyright Release: The proponent of code change proposals, floor modifications and public comments shall sign a copyright release developed and posted by ICC.

3.3.5.6 Cost Impact: The proponent shall indicate one of the following regarding the cost impact of the code change proposal:

- 1) The code change proposal will increase the cost of construction;
- 2) The code change proposal will decrease the cost of construction; or
- 3) The code change proposal will not increase or decrease the cost of construction.

The proponent shall submit information which substantiates such assertion. This information will be considered by the code development committee and will be included in the published code change proposal. Supporting documentation may be provided via a link to a website provided by the proponent and included in the cost substantiation statement. The cost substantiation statement shall include the date the link was created.

Any proposal submitted which does not include the requisite cost impact information shall be considered incomplete and shall not be processed.

3.4 Online Submittal: Each code change proposal and all substantiating information shall be submitted online at the website designated by ICC. Two copies of each proposed new referenced standard in hard copy or one copy in electronic form shall

be submitted. Additional copies may be requested when determined necessary by the Secretariat to allow such information to be distributed to the code development committee. Where such additional copies are requested, it shall be the responsibility of the proponent to send such copies to the respective code development committee.

3.5 Submittal Deadline: ICC shall establish and post the submittal deadline for each cycle. The posting of the deadline shall occur no later than 120 days prior to the code change deadline. Each code change proposal shall be submitted online at the website designated by ICC by the posted deadline. The submitter of a code change proposal is responsible for the proper and timely receipt of all pertinent materials by the Secretariat.

3.6 Referenced Standards: In order for a standard to be considered for reference or to continue to be referenced by the Codes, a standard shall meet the following criteria:

3.6.1 Code References:

3.6.1.1 The standard, including title and date, and the manner in which it is to be utilized shall be specifically referenced in the Code text.

3.6.1.2 The need for the standard to be referenced shall be established.

3.6.2 Standard Content:

3.6.2.1 A standard or portions of a standard intended to be enforced shall be written in mandatory language.

3.6.2.2 The standard shall be appropriate for the subject covered.

3.6.2.3 All terms shall be defined when they deviate from an ordinarily accepted meaning or a dictionary definition.

3.6.2.4 The scope or application of a standard shall be clearly described.

3.6.2.5 The standard shall not have the effect of requiring proprietary materials.

3.6.2.6 The standard shall not prescribe a proprietary agency for quality control or testing.

3.6.2.7 The test standard shall describe, in detail, preparation of the test sample, sample selection or both.

3.6.2.8 The test standard shall prescribe the reporting format for the test results. The format shall identify the key performance criteria for the element(s) tested.

3.6.2.9 The measure of performance for which the test is conducted shall be clearly defined in either the test standard or in Code text.

3.6.2.10 The standard shall not state that its provisions shall govern whenever the referenced standard is in conflict with the requirements of the referencing Code.

3.6.2.11 The preface to the standard shall announce that the standard is promulgated according to a consensus procedure.

3.6.3 Standard Promulgation:

3.6.3.1 Code change proposals with corresponding changes to the code text which include a reference to a proposed new standard or a proposed update of an existing referenced standard shall comply with this section.

3.6.3.1.1 Proposed New Standards. In order for a new standard to be considered for reference by the Code, such standard shall be submitted in at least a consensus draft form in

accordance with Section 3.4. If the proposed new standard is not submitted in at least consensus draft form, the code change proposal shall be considered incomplete and shall not be processed. The code change proposal shall be considered at the Committee Action Hearing by the applicable code development committee responsible for the corresponding proposed changes to the code text. If the committee action at the Committee Action Hearing is either As Submitted or As Modified and the standard is not completed, the code change proposal shall automatically be placed on the Public Comment Agenda with the recommendation stating that in order for the public comment to be considered, the new standard shall be completed and readily available prior to the Public Comment Hearing. If the committee action at the Committee Action Hearing is Disapproval, further consideration on the Public Comment Agenda shall include a recommendation stating that in order for the public comment to be considered, the new standard shall be completed and readily available prior to the Public Comment Hearing.

3.6.3.1.2 Update of Existing Standards. Code change proposals which include technical revisions to the code text to coordinate with a proposed update of an existing referenced standard shall include the submission of the proposed update to the standard in at least a consensus draft form in accordance with Section 3.4. If the proposed update of the existing standard is not submitted in at least consensus draft form, the code change proposal shall be considered incomplete and shall not be processed. The code change proposal, including the update of the existing referenced standard, shall be considered at the Committee Action Hearing by the applicable code development committee responsible for the corresponding changes to the code text. If the committee action at the Committee Action Hearing is either As Submitted or As Modified and the updated standard is not completed, the code change proposal shall automatically be placed on the Public Comment Agenda with the recommendation stating that in order for the public comment to be considered, the updated standard shall be completed and readily available prior to the Public Comment Hearing. If the committee action at the Committee Action Hearing is Disapproval, further consideration on the Public Comment Agenda shall include a recommendation stating that in order for the public comment to be considered, the updated standard shall be completed and readily available prior to the Public Comment Hearing.

Updating of standards without corresponding code text changes shall be accomplished administratively in accordance with Section 4.6.

3.6.3.2 The standard shall be developed and maintained through a consensus process such as ASTM or ANSI.

4.0 Processing of Code Change Proposals

4.1 Intent: The processing of code change proposals is intended to ensure that each proposal complies with these Rules of Procedure and that the resulting published code change proposal accurately reflects that proponent's intent.

- 4.2 Review:** Upon receipt in the Secretariat's office, the code change proposals will be checked for compliance with these Rules of Procedure as to division, separation, number of copies, form, language, terminology, supporting statements and substantiating data. Where a code change proposal consists of multiple parts which fall under the maintenance responsibilities of different code committees, the Secretariat shall determine the code committee responsible for determining the committee action in accordance with Section 5.6 and the Code Scoping Coordination Matrix (see Section 1.3.1).
- 4.3 Incomplete Code Change Proposals:** When a code change proposal is submitted with incorrect format, without the required information or judged as not in compliance with these Rules of Procedure, the Secretariat shall notify the proponent of the specific deficiencies and the proposal shall be held until the deficiencies are corrected, with a final date set for receipt of a corrected submittal. If the Secretariat receives the corrected code change proposal after the final date, the proposal shall be held over until the next code development cycle. Where there are otherwise no deficiencies addressed by this section, a code change proposal that incorporates a new referenced standard shall be processed with an analysis of the referenced standard's compliance with the criteria set forth in Section 3.6.
- 4.4 Editorial Code Change Proposals.** When a code change proposal is submitted that proposes an editorial or format change that, in the opinion of the Secretariat, does not affect the scope or application of the code, the proposal shall be submitted to the Code Correlation Committee who shall deem the code change proposal as editorial or send the proposal back to the Secretariat to be considered by the appropriate code development committee. To be deemed editorial, such proposal shall require a majority vote of the Code Correlation Committee. Editorial proposals shall be published in the Code Change Agenda. Such proposals shall be added to the hearing agenda for consideration by the appropriate code development committee upon written request to ICC by any individual. The deadline to submit such requests shall be 14 days prior to the first day of the Committee Action Hearing. Code Correlation Committee proposals that are not added to a code development committee hearing agenda shall be published in the next edition of the code with no further consideration.
- 4.5 Copy Editing Code Text:** The Chief Executive Officer shall have the authority at all times to make editorial style and format changes to the Code text, or any approved changes, consistent with the intent, provisions and style of the Code. Such editorial style or format changes shall not affect the scope or application of the Code requirements.
- 4.6 Updating Standards Referenced in the Codes:** Standards referenced by the Codes that do not require coordination with a code change proposal to the code text shall be updated administratively by the Administrative Code Development Committee in accordance with these full procedures except that the deadline for availability of the updated standard and receipt by the Secretariat shall be December 1 of the third year of each code cycle. The published version of the new edition of the Code which references the standard will refer to the updated edition of the standard. If the standard is not available by the December 1st deadline, the edition of the standard as referenced by the newly published Code shall revert back to the reference contained in the previous edition and an errata to the Code issued. Multiple standards to be updated may be included in a single proposal.
- 4.7 Preparation:** All code change proposals in compliance with these procedures shall be prepared in a standard manner by the Secretariat and be assigned separate,

distinct and consecutive numbers. The Secretariat shall coordinate related proposals submitted in accordance with Section 3.3.2 to facilitate the hearing process.

- 4.8 Code Change Agenda:** All code change proposals shall be posted on the ICC website at least 30 days prior to the Committee Action Hearing on those proposals and shall constitute the agenda for the Committee Action Hearing. Any errata to the Code Change Agenda shall be posted on the ICC website as soon as possible. Code change proposals which have not been published in the original posting or subsequent errata shall not be considered.

5.0 Committee Action Hearing

- 5.1 Intent:** The intent of the Committee Action Hearing is to permit interested parties to present their views including the cost and benefits on the code change proposals on the published agenda. The code development committee will consider such comments as may be presented in the development of their action on the disposition of such code change proposals. At the conclusion of the code development committee deliberations, the committee action on each code change proposal shall be placed before the hearing assembly for consideration in accordance with Section 5.7.

- 5.2 Committee:** The Codes and Standards Council shall review all applications and make committee appointment recommendations to the ICC Board. The Code Development Committees shall be appointed by the ICC Board.

5.2.1 Chairman/Moderator: The Chairman and Vice-Chairman shall be appointed by the Codes and Standards Council from the appointed members of the committee. The ICC President shall appoint one or more Moderators who shall act as presiding officer for the Committee Action Hearing.

5.2.2 Conflict of Interest: A committee member shall withdraw from and take no part in those matters with which the committee member has an undisclosed financial, business or property interest. The committee member shall not participate in any committee discussion or any committee vote on the matter in which they have an undisclosed interest. A committee member who is a proponent of a code change proposal shall not participate in any committee discussion on the matter or any committee vote. Such committee member shall be permitted to participate in the floor discussion in accordance with Section 5.5 by stepping down from the dais.

5.2.3 Representation of Interest: Committee members shall not represent themselves as official or unofficial representatives of the ICC except at regularly convened meetings of the committee.

5.2.4 Committee Composition: The committee may consist of representation from multiple interests. A minimum of thirty-three and one-third percent (33.3%) of the committee members shall be regulators.

- 5.3 Date and Location:** The date and location of the Committee Action Hearing shall be announced not less than 60 days prior to the date of the hearing.

- 5.4 General Procedures:** *The Robert's Rules of Order* shall be the formal procedure for the conduct of the Committee Action Hearing except as a specific provision of these Rules of Procedure may otherwise dictate. A quorum shall consist of a majority of the voting members of the committee.

- 5.4.1 Chair Voting:** The Chairman of the committee shall vote only when the vote cast will break a tie vote of the committee.
- 5.4.2 Open Hearing:** The Committee Action Hearing is an open hearing. Any interested person may attend and participate in the floor discussion and assembly consideration portions of the hearing. Only code development committee members may participate in the committee action portion of the hearings (see Section 5.6). Participants shall not advocate a position on specific code change proposals with committee members other than through the methods provided in this policy.
- 5.4.3 Presentation of Material at the Public Hearing:** Information to be provided at the hearing shall be limited to verbal presentations and modifications submitted in accordance with Section 5.5.2. Each individual presenting information at the hearing shall state their name and affiliation, and shall identify any entities or individuals they are representing in connection with their testimony. Audio-visual presentations are not permitted. Substantiating material submitted in accordance with Section 3.3.5.3 and other material submitted in response to a code change proposal shall be located in a designated area in the hearing room and shall not be distributed to the code development committee at the public hearing.
- 5.4.4 Agenda Order:** The Secretariat shall publish a Code Change Agenda for the Committee Action Hearing, placing individual code change proposals in a logical order to facilitate the hearing. Any public hearing attendee may move to revise the agenda order as the first order of business at the public hearing, or at any time during the hearing except while another code change proposal is being discussed. Preference shall be given to grouping like subjects together, and for moving items back to a later position on the agenda as opposed to moving items forward to an earlier position.
- 5.4.4.1 Proponent Approval:** A motion to revise the agenda order is considered in order unless the proponent(s) of the moved code change proposals are in attendance in the hearing room and object to the move. Where such objections are raised, the motion to revise the hearing order shall be ruled out of order by the Moderator. The ruling of the Moderator shall be final and not subject to a point of order in accordance with Section 5.4.8. The motion to change the hearing order is not debatable.
- 5.4.4.2 Revised Agenda Order Approved:** A motion to revise the agenda order is subject to a 2/3 vote of those present.
- 5.4.5 Tabling:** Tabling of code change proposals shall be permitted. The motion to table is considered in order unless the proponent(s) of the tabled code change proposals are in attendance at the hearing and object to the tabling. Where such objections are raised, the motion to table shall be ruled out of order by the Moderator. The ruling of the Moderator shall be final and not subject to a point of order in accordance with Section 5.4.8. The motion to table is not debatable.

The motion to table must identify one of the following as to the location in the agenda when or where the code change proposal(s) will be considered:

1. To a specific date and time within the timeframe of the Code Change Agenda for the code change proposals under

- consideration, or
2. To a specific location in the Code Change Agenda for the code change proposals under consideration.

5.4.5.1 Tabling approved: A motion to table is subject to a 2/3 vote of those present.

5.4.5.2 Tabled code change proposals back to the floor: The Moderator shall bring the tabled code change proposal(s) back to the floor at the applicable time/agenda location in accordance with Section 5.4.5 Items 1 or 2. The testimony on the code change proposal shall resume at the point in the process where the tabling occurred.

5.4.6 Reconsideration: There shall be no reconsideration of a code change proposal after it has been voted on by the committee in accordance with Section 5.6.

5.4.7 Time Limits: Time limits shall be established as part of the agenda for testimony on all code change proposals at the beginning of each hearing session. Each person requesting to testify on a code change proposal shall be given equal time. In the interest of time and fairness to all hearing participants, the Moderator shall have limited authority to modify time limitations on debate. The Moderator shall have the authority to adjust time limits as necessary in order to complete the hearing agenda.

5.4.7.1 Time Keeping: Keeping of time for testimony by an individual shall be by an automatic timing device. Remaining time shall be evident to the person testifying. Interruptions during testimony shall not be tolerated. The Moderator shall maintain appropriate decorum during all testimony.

5.4.7.2 Proponent Testimony: The Proponent is permitted to waive an initial statement. The Proponent shall be permitted to have the amount of time that would have been allocated during the initial testimony period plus the amount of time that would be allocated for rebuttal. Where the code change proposal is submitted by multiple proponents, this provision shall permit only one proponent of the joint submittal to be allotted additional time for rebuttal.

5.4.8 Points of Order: Any person participating in the public hearing may challenge a procedural ruling of the Moderator or the Chairman. A majority vote of ICC Members in attendance shall determine the decision.

5.5 Floor Discussion: The Moderator shall place each code change proposal before the hearing for discussion by identifying the proposal and by regulating discussion as follows:

5.5.1 Discussion Order:

1. Proponents. The Moderator shall begin by asking the proponent and then others in support of the code change proposal for their comments.
2. Opponents. After discussion by those in support of a code change proposal, those opposed hereto, if any, shall have the opportunity to present their views.
3. Rebuttal in support. Proponents shall then have the opportunity to rebut

points raised by the opponents.

4. Re-rebuttal in opposition. Opponents shall then have the opportunity to respond to the proponent's rebuttal.

5.5.2 Modifications: Modifications to code change proposals may be suggested from the floor by any person participating in the public hearing. The person proposing the modification, or his/her designee, is deemed to be the proponent of the modification.

5.5.2.1 Submission. All modifications shall be submitted electronically to the ICC Secretariat in a format determined by ICC unless determined by the Chairman to be either editorial or minor in nature. The modification will be forwarded electronically to the members of the code development committee during the hearing and will be projected on the screen in the hearing room.

5.5.2.2 Criteria. The Chairman shall rule proposed modifications in or out of order before they are discussed on the floor. A proposed modification shall be ruled out of order if it:

1. changes the scope of the original code change proposal; or
2. is not readily understood to allow a proper assessment of its impact on the original code change proposal or the Code.

The ruling of the Chairman on whether or not the modification is in or out of order shall be final and is not subject to a point of order in accordance with Section 5.4.8.

5.5.2.3 Testimony. When a modification is offered from the floor and ruled in order by the Chairman, a specific floor discussion on that modification is to commence in accordance with the procedures listed in Section 5.5.1.

5.6 Committee Action: Following the floor discussion of each code change proposal, one of the following motions shall be made and seconded by members of the committee:

1. Approve the code change proposal As Submitted (AS) or
2. Approve the code change proposal As Modified with specific modifications (AM), or
3. Disapprove the code change proposal (D)

Discussion on this motion shall be limited to code development committee members. If a committee member proposes a modification which had not been proposed during floor discussion, the Chairman shall rule on the modification in accordance with Section 5.5.2.2. If a committee member raises a matter of issue, including a proposed modification, which has not been proposed or discussed during the floor discussion, the Moderator shall suspend the committee discussion and shall reopen the floor discussion for comments on the specific matter or issue. Upon receipt of all comments from the floor, the Moderator shall resume committee discussion.

The code development committee shall vote on each motion with the majority dictating the committee's action. Committee action on each code change proposal shall be completed when one of the motions noted above has been approved. Each committee vote shall be supported by a reason.

The code development committee shall maintain a record of its proceedings including the action on each code change proposal.

5.7 Assembly Consideration: At the conclusion of the committee's action on a code change proposal and before the next code change proposal is called to the floor, the Moderator shall ask for a motion from the public hearing attendees who may object to the committee's action. If a motion in accordance with Section 5.7.1 is not brought forward on the committee's action, the results of the Committee Action Hearing shall be established by the committee's action.

5.7.1 Assembly Floor Motion: Any attendee may raise an objection to the committee's action in which case the attendee will be able to make a motion to:

1. Approve the code change proposal As Submitted from the Floor (ASF), or
2. Approve the code change proposal As Modified from the Floor (AMF) with a specific modification that has been previously offered from the floor and ruled in order by the Chairman during floor discussion (see Section 5.5.2) or has been offered by a member of the Committee and ruled in order by the Chairman during committee discussion (see Section 5.6), or
3. Disapprove the code change proposal from the floor (DF).

5.7.2 Assembly Floor Motion Consideration: On receipt of a second to the floor motion, the Moderator shall accept the motion and the second and notify the attendees that the motion will be considered in an online ballot following the hearing in accordance with Section 5.7.3. No additional testimony shall be permitted.

5.7.3 Online Assembly Floor Motion Ballot: Following the Committee Action Hearing, all assembly floor motions which received a second shall be compiled into an online ballot. The ballot will include:

1. The code change proposal as published.
2. The committee action and reason from the Committee Action Hearing.
3. The floor motion, including modifications which are part of the floor motion.
4. Access to the audio and video of the Committee Action Hearing proceedings.
5. Identification of the ballot period for which the online balloting will be open.

5.7.4 Eligible Online Assembly Motion Voters: All members of ICC shall be eligible to vote on online assembly floor motions. Each member is entitled to one vote, except that each Governmental Member Voting Representative may vote on behalf of its Governmental Member. Individuals who represent more than one Governmental Member shall be limited to a single vote. Application, whether new or updated, for ICC membership must be received by the Code Council 30 days prior to the first day of the Committee Action Hearing. The ballot period will not be extended beyond the published period except as approved by the ICC Board.

5.7.5 Assembly Action: A successful assembly action shall be a majority vote of the votes cast by eligible voters (see Section 5.7.4). A successful assembly action results in an automatic public comment to be considered at the Public

Comment Hearing (see Section 7.4).

- 5.8 Report of the Committee Action Hearing:** The results of the Committee Action Hearing, including committee action and reason, online assembly floor motion vote results and the total vote count for each assembly floor motion shall be posted on the ICC website not less than 60 days prior to the Public Comment Hearing, except as approved by the ICC Board.

6.0 Public Comments

- 6.1 Intent:** The public comment process gives attendees at the Public Comment Hearing an opportunity to consider specific objections to the results of the Committee Action Hearing and more thoughtfully prepare for the discussion for public comment consideration. The public comment process expedites the Public Comment Hearing by limiting the items discussed to the following:

1. Consideration of items for which a public comment has been submitted; and
2. Consideration of items which received a successful assembly action.

- 6.2 Deadline:** The deadline for receipt of a public comment to the results of the Committee Action Hearing shall be announced at the Committee Action Hearing but shall not be less than 30 days subsequent to the availability of the Report of the Committee Action Hearing (see Section 5.8).

- 6.3 Withdrawal of Public Comment:** A public comment may be withdrawn by the public commenter at any time prior to public comment consideration of that comment. A withdrawn public comment shall not be subject to public comment consideration. If the only public comment to a code change proposal is withdrawn by the public commenter prior to the vote on the consent agenda in accordance with Section 7.5.5, the proposal shall be considered as part of the consent agenda. If the only public comment to a code change proposal is withdrawn by the public commenter after the vote on the consent agenda in accordance with Section 7.5.5, the proposal shall continue as part of the individual consideration agenda in accordance with Section 7.5.6, however the public comment shall not be subject to public comment consideration.

- 6.4 Form and Content of Public Comments:** Any interested person, persons, or group may submit a public comment to the results of the Committee Action Hearing which will be considered when in conformance to these requirements. Each public comment to a code change proposal shall be submitted separately and shall be complete in itself. Each public comment shall contain the following information:

- 6.4.1 Public comment:** Each public comment shall include the name, title, mailing address, telephone number and email address of the public commenter. Email addresses shall be published with the public comments unless the commenter otherwise requests on the submittal form.

If a group, organization, or committee submits a public comment, an individual with prime responsibility shall be indicated. If a public comment is submitted on behalf a client, group, organization or committee, the name and mailing address of the client, group, organization or committee shall be indicated. The scope of the public comment shall be consistent with the scope of the original code change proposal, committee action or successful assembly action. Public comments which are determined as not within the scope of the code change proposal, committee action or successful assembly action shall be identified as such. The public commenter shall be notified that the public comment is considered an incomplete public

comment in accordance with Section 6.5.1 and the public comment shall be held until the deficiencies are corrected. A copyright release in accordance with Section 3.3.5.5 shall be provided with the public comment.

6.4.2 Code Reference: Each public comment shall include the code change proposal number.

6.4.3 Multiple public comments to a code change proposal. A proponent shall not submit multiple public comments to the same code change proposal. When a proponent submits multiple public comments to the same code change proposal, the public comments shall be considered as incomplete public comments and processed in accordance with Section 6.5.1. This restriction shall not apply to public comments that attempt to address differing subject matter within a code section.

6.4.4 Desired Final Action: In order for a public comment to be considered, the public comment shall indicate the desired Final Action as one of the following:

1. Approve the code change proposal As Submitted (AS), or
2. Approve the code change proposal As Modified by the committee modification published in the Report of the Committee Action Hearing (AM) or published in a public comment in the Public Comment Agenda (AMPC), or
3. Disapprove the code change proposal (D)

6.4.5 Supporting Information: The public comment shall include a statement containing a reason and justification for the desired Final Action on the code change proposal. Reasons and justification which are reviewed in accordance with Section 6.5 and determined as not germane to the technical issues addressed in the code change proposal or committee action may be identified as such. The public commenter shall be notified that the public comment is considered an incomplete public comment in accordance with Section 6.5.1 and the public comment shall be held until the deficiencies are corrected. The public commenter shall have the right to appeal this action in accordance with the policy of the ICC Board. A bibliography of any substantiating material submitted with a public comment shall be published with the public comment and the substantiating material shall be made available at the Public Comment_Hearing. Supporting documentation may be provided via a link to a website provided by the public commenter and included in the reason statement and bibliography. The reason statement shall include the date the link was created. All substantiating material published by ICC is material that has been provided by the proponent and in so publishing ICC makes no representations or warranties about its quality or accuracy.

6.4.6 Cost Impact: The proponent of the public comment shall indicate one of the following regarding the cost impact of the public comment to the code change proposal:

- 1) The net effect of the public comment and code change proposal will increase the cost of construction;
- 2) The net effect of the public comment and code change proposal will decrease the cost of construction; or
- 3) The net effect of the public comment and code change proposal will not increase or decrease the cost of construction.

The public commenter shall submit information which substantiates such assertion. This information will be considered at the Public Comment Hearing and will be included in the published public comment. Supporting documentation may be provided via a link to a website provided by the public commenter and included in the cost substantiation statement. The cost substantiation statement shall include the date the link was created.

Any public comment submitted which does not include the requisite cost impact information shall be considered incomplete and shall not be processed.

6.4.7 Online submittal: Each public comment and substantiating information shall be submitted online at the website designated by ICC. Additional copies may be requested when determined necessary by the Secretariat.

6.4.8 Submittal Deadline: ICC shall establish and post the submittal deadline for each cycle. The posting of the deadline shall occur no later than 120 days prior to the public comment deadline. Each public comment shall be submitted online at the website designated by ICC by the posted deadline. The submitter of a public comment is responsible for the proper and timely receipt of all pertinent materials by the Secretariat.

6.5 Review: The Secretariat shall be responsible for reviewing all submitted public comments from an editorial and technical viewpoint similar to the review of code change proposals (see Section 4.2).

6.5.1 Incomplete Public Comment: When a public comment is submitted with incorrect format, without the required information or judged as not in compliance with these Rules of Procedure, the public comment shall not be processed. The Secretariat shall notify the public commenter of the specific deficiencies and the public comment shall be held until the deficiencies are corrected, or the public comment shall be returned to the public commenter with instructions to correct the deficiencies with a final date set for receipt of the corrected public comment.

6.5.2 Duplications: On receipt of duplicate or parallel public comments, the Secretariat may consolidate such public comments for public comment consideration. Each public commenter shall be notified of this action when it occurs.

6.5.3 Deadline: Public comments received by the Secretariat after the deadline set for receipt shall not be published and shall not be considered as part of the public comment consideration. This deadline shall not apply to public comments submitted by the Code Correlation Committee. In order to correlate submitted public comments with action taken at the Committee Action Hearing on code change proposals that did receive a public comment, the Code Correlation Committee, in conjunction with staff processing of public comments, shall review the submitted public comments and submit the necessary public comments in order to facilitate the coordination of code change proposals. Such review and submittal shall not delay the posting of the Public Comment Agenda as required in Section 6.6.

6.6 Public Comment Agenda: The Committee Action Hearing results on code change proposals that have not received a public comment and code change proposals which received public comments or successful assembly actions shall constitute the Public Comment Agenda. The Public Comment Agenda shall be posted on the

ICC website at least 30 days prior the Public Comment Hearing. Any errata to the Public Comment Agenda shall be posted on the ICC website as soon as possible. Code change proposals and public comments which have not been published in the original posting or subsequent errata shall not be considered.

7.0 Public Comment Hearing

- 7.1 Intent:** The Public Comment Hearing is the first of two steps to make a final determination on all code change proposals which have been considered in a code development cycle by a vote cast by eligible voters (see Section 9.0). The second step, which follows the Public Comment Hearing, is the Online Governmental Consensus Vote that is conducted in accordance with Section 8.0.
- 7.2 Date and Location:** The date and location of the Public Comment Hearing shall be announced not less than 60 days prior to the date of the hearing.
- 7.3 Moderator:** The ICC President shall appoint one or more Moderators who shall act as presiding officer for the Public Comment Hearing.
- 7.4 Public Comment Agenda:** The Public Comment Consent Agenda shall be comprised of code change proposals which have neither a successful assembly action nor public comment. The agenda for public testimony and individual consideration shall be comprised of proposals which have a successful assembly action or public comment (see Section 6.1).
- 7.5 Procedure:** *The Robert's Rules of Order* shall be the formal procedure for the conduct of the Public Comment Hearing except as these Rules of Procedure may otherwise dictate.
- 7.5.1 Open Hearing:** The Public Comment Hearing is an open hearing. Any interested person may attend and participate in the floor discussion.
- 7.5.2 Agenda Order:** The Secretariat shall publish a Public Comment Agenda for the Public Comment Hearing, placing individual code change proposals and public comments in a logical order to facilitate the hearing. The proponents or opponents of any code change proposal or public comment may move to revise the agenda order as the first order of business at the public hearing, or at any time during the hearing except while another proposal is being discussed. Preference shall be given to grouping like subjects together and for moving items back to a later position on the agenda as opposed to moving items forward to an earlier position.
- 7.5.2.1 Proponent Approval:** A motion to revise the agenda order is considered in order unless the proponent(s) of the moved code change proposals are in attendance at the hearing and object to the move. Where such objections are raised, the motion to revise the hearing order shall be ruled out of order by the Moderator. The ruling of the Moderator shall be final and not subject to a point of order in accordance with Section 5.4.8. The motion to change the hearing order is not debatable.
- 7.5.2.2 Revised Agenda Order Approved:** A motion to revise the agenda order is subject to a 2/3 vote of those present.
- 7.5.3 Tabling:** Tabling of code change proposals shall be permitted. The motion to table is considered in order unless the proponent(s) of the tabled code change proposals are in attendance at the hearing and object to the tabling. Where such objections are raised, the motion to table shall be ruled out of

order by the Moderator. The ruling of the Moderator shall be final and not subject to a point of order in accordance with Section 5.4.8. The motion to table is not debatable.

The motion to table must identify one of the following as to the location in the agenda when or where the code change proposal(s) will be considered:

1. To a specific date and time within the timeframe of the Public Comment Agenda for the code change proposals under consideration, or
2. To a specific location in the Public Comment Agenda for the code change proposals under consideration.

7.5.3.1 Tabling approved: A motion to table is subject to a 2/3 vote of those present.

7.5.3.2 Tabled code change proposals back to the floor: The Moderator shall bring the tabled code change proposal(s) back to the floor at the applicable time/agenda location in accordance with Section 7.5.3 Items 1 or 2. The testimony on the code change proposal shall resume at the point in the process where the tabling occurred.

7.5.4 Presentation of Material at the Public Comment Hearing: Information to be provided at the hearing shall be limited to verbal presentations. Each individual presenting information at the hearing shall state their name and affiliation, and shall identify any entities or individuals they are representing in connection with their testimony. Audio-visual presentations are not permitted. Substantiating material submitted in accordance with Section 6.4.5 and other material submitted in response to a code change proposal or public comment shall be located in a designated area in the hearing room.

7.5.5 Public Comment Consent Agenda: The Public Comment Consent Agenda (see Section 7.4) shall be placed before the assembly with a single motion for Final Action in accordance with the results of the Committee Action Hearing. When the motion has been seconded, the vote shall be taken with no testimony being allowed. A simple majority (50% plus one) based on the number of votes cast by eligible voters shall decide the motion. This action shall not be subject to the Online Governmental Consensus Vote following the Public Comment Hearing (see Section 8.0).

7.5.6 Public Comment Individual Consideration Agenda: Upon completion of the Public Comment Consent Agenda vote, all code change proposals not on the Public Comment Consent Agenda shall be placed before the assembly for individual consideration of each item (see Section 7.4).

7.5.7 Reconsideration: There shall be no reconsideration of a code change proposal after it has been voted on in accordance with Section 7.5.9.

7.5.8 Time Limits: Time limits shall be established as part of the agenda for testimony on all code change proposals at the beginning of each hearing session. Each person requesting to testify on a code change proposal shall be given equal time. In the interest of time and fairness to all hearing participants, the Moderator shall have limited authority to modify time limitations on debate. The Moderator shall have the authority to adjust time limits as necessary in order to complete the hearing agenda.

7.5.8.1 Time Keeping: Keeping of time for testimony by an individual

shall be by an automatic timing device. Remaining time shall be evident to the person testifying. Interruptions during testimony shall not be tolerated. The Moderator shall maintain appropriate decorum during all testimony.

7.5.9 Discussion and Voting: Discussion and voting on code change proposals being individually considered shall be in accordance with the following procedures and the voting majorities in Section 7.6:

7.5.9.1 Proponent testimony: The Proponent of a public comment is permitted to waive an initial statement. The Proponent of the public comment shall be permitted to have the amount of time that would have been allocated during the initial testimony period plus the amount of time that would be allocated for rebuttal. Where a public comment is submitted by multiple proponents, this provision shall permit only one proponent of the joint submittal to waive an initial statement.

7.5.9.2 Points of Order: Any person participating in the public hearing may challenge a procedural ruling of the Moderator. A majority vote of ICC Members in attendance shall determine the decision.

7.5.9.3 Eligible voters: Voting shall be limited to eligible voters in accordance with Section 9.0.

7.5.9.4 Allowable Final Action Motions: The only allowable motions for Final Action are Approval as Submitted (AS), Approval as Modified by the committee (AM) or by one or more modifications published in the Public Comment Agenda (AMPC), and Disapproval (D).

7.5.9.5 Initial Motion: The code development committee action shall be the initial motion considered.

7.5.9.6 Motions for Modifications: Whenever a motion under consideration is for Approval as Submitted or Approval as Modified, a subsequent motion and second for a modification published in the Public Comment Agenda may be made (see Section 6.4.4). Each subsequent motion for modification, if any, shall be individually discussed and voted before returning to the main motion. A two-thirds majority based on the number of votes cast by eligible voters shall be required for a successful motion on all modifications.

7.5.9.7 Voting: After dispensing with all motions for modifications, if any, and upon completion of discussion on the main motion, the Moderator shall then ask for the vote on the main motion. The vote on the main motion shall be taken electronically with the vote recorded and each vote assigned to the eligible voting member. In the event the electronic voting system is determined not to be used by ICC, a hand/standing count will be taken by the Moderator. If the motion fails to receive the majority required in Section 7.6, the Moderator shall ask for a new motion.

7.5.9.8 Subsequent Motion: If the initial motion is unsuccessful, a motion for either Approval as Submitted or Approval as Modified by one or more published modifications is in order. A motion for

Disapproval is not in order. The vote on the main motion shall be taken electronically with the vote recorded and each vote assigned to the eligible voting member. In the event the electronic voting system is determined not to be used by ICC, a hand/standing count will be taken by the Moderator. If a successful vote is not achieved, Section 7.5.9.9 shall apply.

7.5.9.9 Failure to Achieve Majority Vote at the Public Comment Hearing. In the event that a code change proposal does not receive any of the required majorities in Section 7.6, the results of the Public Comment Hearing for the code change proposal in question shall be Disapproval. The vote count that will be reported as the Public Comment Hearing result will be the vote count on the main motion in accordance with Section 7.5.9.7.

7.5.9.10 Public Comment Hearing Results: The result and vote count on each code change proposal considered at the Public Comment Hearing shall be announced at the hearing. In the event the electronic voting system is not utilized and a hand/standing count is taken in accordance with Sections 7.5.9.7 and 7.5.9.8, the vote count will not be announced if an individual standing vote count is not taken. The results shall be posted and included in the Online Governmental Consensus Ballot (see Section 8.2).

7.6 Majorities for Final Action: The required voting majority for code change proposals individually considered shall be based on the number of votes cast of eligible voters at the Public Comment Hearing shall be in accordance with the following table:

Committee Action	Desired Final Action		
	AS	AM/AMPC	D
AS	Simple Majority	2/3 Majority	Simple Majority
AM	2/3 Majority	Simple Majority to sustain the Committee Action or; 2/3 Majority on each additional modification and 2/3 Majority on entire code change proposal for AMPC	Simple Majority
D	2/3 Majority	2/3 Majority	Simple Majority

8.0 Online Governmental Consensus Vote

8.1 Public Comment Hearing Results: The results from the Individual Consideration Agenda at the Public Comment Hearing (see Sections 7.5.6 and 7.5.9.10) shall be the basis for the Online Governmental Consensus Vote. The ballot shall include the voting options in accordance with the following table:

Committee Action	Public Comment Hearing result and Voting Majority	Online Governmental Consensus Ballot and Voting Majority	
AS	AS: Simple Majority	AS: Simple Majority	D: Simple Majority
	AMPC: 2/3 Majority	AMPC: 2/3 Majority	D: Simple Majority
	D: Simple Majority	AS: Simple Majority	D: Simple Majority

AM	AS: 2/3 Majority	AS: 2/3 Majority	D: Simple Majority
	AM: Simple Majority	AM: Simple Majority	D: Simple Majority
	AMPC: 2/3 Majority	AMPC: 2/3 Majority	D: Simple Majority
	D: Simple Majority	AM: Simple Majority	D: Simple Majority
D	AS: 2/3 Majority	AS: 2/3 Majority	D: Simple Majority
	AMPC: 2/3 Majority	AMPC: 2/3 Majority	D: Simple Majority
	D: Simple Majority	AS: 2/3 Majority	D: Simple Majority

8.2 Online Governmental Consensus Ballot: The ballot for each code change proposal considered at the Public Comment Hearing will include:

1. The Public Comment Hearing result and vote count.
2. The allowable Online Governmental Consensus Vote actions in accordance with Section 8.1.
3. Where the Public Comment Hearing result is As Submitted (AS) or Disapproval (D), the original code change proposal will be presented.
4. Where the Public Comment Hearing result is As Modified by the committee (AM) or As Modified by one or more Public Comments (AMPC), the original code change and approved modification(s) will be presented.
5. The committee action taken at the Committee Action Hearing.
6. ICC staff identification of correlation issues.
7. For those who voted at the Public Comment Hearing, the ballot will indicate how they voted, unless an electronic vote count is not taken in accordance with Section 7.5.9.10.
8. An optional comment box to provide comments.
9. Access to the Public Comment Agenda which includes: the original code change, the report of the committee action and the submitted public comments.
10. Access to the audio and video of the Committee Action and Public Comment Hearing proceedings.
11. Identification of the ballot period for which the online balloting will be open.

8.3 Voting process: Voting shall be limited to eligible voters in accordance with Section 9.0. Eligible voters are authorized to vote during the Public Comment Hearing and during the Online Governmental Consensus Vote; however, only the last vote cast will be included in the final vote tabulation. The ballot period will not be extended beyond the published period except as approved by the ICC Board.

8.3.1 Participation requirement: A minimum number of participants to conduct the Online Governmental Consensus Vote shall not be required unless the code change proposal(s) were not voted upon utilizing the electronic voting devices at the Public Comment Hearing and the resulting vote was not assigned to each eligible voting member in accordance with Sections 7.5.9.7 and 7.5.9.8 . If this occurs, a minimum number of participants shall be required for those code change proposal(s) based on an assessment of the minimum number of votes cast during the entire Public Comment Hearing and the Online Governmental Consensus Vote shall determine the final on action on the code change proposal(s) in accordance with Section 10.1.

9.0 Eligible Final Action Voters

9.1 Eligible Final Action Voters: Eligible Final Action voters include ICC Governmental Member Voting Representatives and Honorary Members in good standing who have been confirmed by ICC in accordance with the Electronic Voter Validation System. Such confirmations are required to be revalidated annually. Eligible Final Action voters in attendance at the Public Comment Hearing and those

participating in the Online Governmental Consensus Vote shall have one vote per eligible voter on all Codes. Individuals who represent more than one Governmental Member shall be limited to a single vote.

- 9.2 Applications:** Applications for Governmental Membership must be received by the ICC at least 30 days prior to the Committee Action Hearing in order for its designated representatives to be eligible to vote at the Public Comment Hearing or Online Governmental Consensus Vote. Applications, whether new or updated, for Governmental Member Voting Representative status must be received by the Code Council 30 days prior to the commencement of the first day of the Public Comment Hearing in order for any designated representative to be eligible to vote. An individual designated as a Governmental Member Voting Representative shall provide sufficient information to establish eligibility as defined in the ICC Bylaws. The Executive Committee of the ICC Board, in its discretion, shall have the authority to address questions related to eligibility.

10.0 Tabulation, certification and posting of results

- 10.1 Tabulation and Validation:** Following the closing of the online ballot period, the votes received will be combined with the vote tally at the Public Comment Hearing to determine the final vote on the code change proposal. If a hand/standing count is utilized per Subsection 7.5.9.7 or 7.5.9.8, those votes of the Public Comment Hearing will not be combined with the online ballot. ICC shall retain a record of the votes cast and the results shall be certified by a validation committee appointed by the ICC Board. The validation committee shall report the results to the ICC Board, either confirming a valid voting process and result or citing irregularities in accordance with Section 10.2.

- 10.2 Voting Irregularities:** Where voting irregularities or other concerns with the Online Governmental Consensus Voting process which are material to the outcome or the disposition of a code change proposal(s) are identified by the validation committee, such irregularities or concerns shall be immediately brought to the attention of the ICC Board. The ICC Board shall take whatever action necessary to ensure a fair and impartial Final Action vote on all code change proposals, including but not limited to:

1. Set aside the results of the Online Governmental Consensus Vote and have the vote taken again.
2. Set aside the results of the Online Governmental Consensus Vote and declare the Final Action on all code change proposals to be in accordance with the results of the Public Comment Hearing.
3. Other actions as determined by the ICC Board.

- 10.3 Failure to Achieve Majority Vote:** In the event a code change proposal does not receive any of the required majorities for Final Action in Section 8.0, Final Action on the code change proposal in question shall be Disapproval.

- 10.4 Final Action Results:** The Final Action on all code change proposals shall be published as soon as practicable after certification of the results. The results shall include the Final Action taken, including the vote tallies from both the Public Comment Hearing and Online Governmental Consensus Vote, as well the required majority in accordance with Section 8.0. ICC shall maintain a record of individual votes for auditing purposes, however, the record shall not be made public. The exact wording of any resulting text modifications shall be made available to any interested party.

11.0 Code Publication

11.1 Next Edition of the Codes: The Final Action results on code change proposals shall be the basis for the subsequent edition of the respective Code.

11.2 Code Correlation: The Code Correlation Committee is authorized to resolve technical or editorial inconsistencies resulting from actions taken during the code development process by making appropriate changes to the text of the affected code. The process to resolve technical or editorial inconsistencies shall be conducted in accordance with CP#44 Code Correlation Committee.

12.0 Appeals

12.1 Right to Appeal: Any person may appeal an action or inaction in accordance with Council Policy 1 Appeals. Any appeal made regarding voter eligibility, voter fraud, voter misrepresentation or breach of ethical conduct must be supported by credible evidence and must be material to the outcome of the final disposition of a code change proposal(s).

The following actions are not appealable:

1. Variations of the results of the Public Comment Hearing compared to the Final Action result in accordance with Section 10.4.
2. Denied requests to extend the voter balloting period in accordance with Sections 5.7.4 or 8.3.
3. Lack of access to the internet based online collaboration and voting platform to submit a code change proposal, to submit a public comment or to vote.
4. Code Correlation Committee changes made in accordance with Section 11.2.

13.0 Violations

13.1 ICC Board Action on Violations: Violations of the policies and procedures contained in this Council Policy shall be brought to the immediate attention of the ICC Board for response and resolution. Additionally, the ICC Board may take any actions it deems necessary to maintain the integrity of the code development process.

Sections revised in December 8, 2017 revision to CP-28:

3.3.5.5
8.3.1

Sections revised in September 9, 2017 revision to CP-28:

3.2
3.3.5.3
3.3.5.4
3.3.5.6
3.6.3.1.1
3.6.3.1.2
4.6
5.4.4
5.4.4.1
5.4.4.2
5.4.5

5.4.5.1
5.4.5.2
5.5.2
5.5.2.2
6.4.5
6.4.6
7.5.2
7.5.2.1
7.5.2.2
7.5.3
7.5.3.1
7.5.3.2
7.5.9.10
8.2 – Number 7
11.2

2018 ICC CODE DEVELOPMENT CYCLE CROSS INDEX OF PROPOSED CODE CHANGES

Some of the proposed code changes include sections that are outside of the scope of the chapters or the code listed in the table of 2018-2019 Staff Secretaries on page xi. This is done in order to facilitate coordination among the International Codes which is one of the fundamental principles of the International Codes.

Listed in this cross index are proposed code changes that include sections of codes or codes other than those listed on page ix. For example, IBC Section 402.4.2.2 is proposed for revision in code change FS18-18, which is found in the IBC-Fire Safety section of the code change proposal book. This section of the IBC is typically the responsibility of the IBC-General Committee as listed in the table of 2018-2019 Staff Secretaries. It is therefore identified in this cross index. Another example is Section 606.4.1 of the International Mechanical Code. The International Mechanical Code is maintained by the IMC Committee, but Section 606.4.1 will be considered for revision in proposed code change F143 which will be on the IFC Committee agenda. In some instances, there are other subsections that are revised by an identified code change that is not included in the cross index.

This information is provided to assist users in locating all of the proposed code changes that would affect a certain section or chapter. For example, to find all of the proposed code changes that would affect Chapter 4 of the IBC, review the proposed code changes in the portion of the monograph for the IBC-General Code Development Committee (listed with a G prefix) then review this cross reference for Chapter 4 of the IBC for proposed code changes published in other code change groups. While care has been taken to be accurate, there may be some omissions in this list.

Letter prefix: Each proposed change number has a letter prefix that will identify where the proposal is published. The letter designations for proposed changes and the corresponding publications are as follows:

PREFIX	PROPOSED CHANGE GROUP (see monograph table of contents for location)
E	International Building Code - Means of Egress
EB	International Existing Building Code
FG	International Fuel Gas Code
FS	International Building Code - Fire Safety
G	International Building Code – General
M	International Mechanical Code
P	International Plumbing Code
PSD	International Private Sewage Disposal Code
PM	International Property Maintenance Code
RM	International Residential Code - Mechanical
RP	International Residential Code - Plumbing
S	International Building Code – Structural
SP	International Swimming Pool and Spa Code

INTERNATIONAL BUILDING CODE	
Section #	Code Change #
Chapter 2	
Building projection	FS15
Ceiling Radiation Damper	FS62
Continuity of Head-of-Wall Joint System	FS30, FS31
Control vestibule	E49
Electric Vehicle Charging Station	E121
Exterior Wall Envelope	FS136
F-Rating	FS53, FS30, FS 31
Firestop Identification Device	FS46
Insulated Vinyl Siding	FS114
Intumescent Fire-resistant materials	FS10
Life Safety Systems	F4 Part II
Live Load, Roof	FS153
Opening, Exterior	FS11
Perimeter Fire Containment System	FS53
Platform construction	FS20
Smoke compartment	FS38
Spray Applied Foam Plastic	FS155
T-rating	FS30, FS31
Terminated stops	FS60
Wind Driven Rain Index	FS93
Chapter 3	
307.1	F18, F280
Table 307.1(1)	F280, F281, F282, F293
Table 307.1(2)	F40
307.1.1	F271, F276, F293, F299
307.4	F18
311.2	F276
311.3	F276
Chapter 4	
402.4.2.2	FS18
402.4.2.3	FS18
402.6.2	F40
402.7.5	F112
403.3.3	F175
403.4.5	F45
403.4.8.2	F196
404.9.3	E19
406.2.7	E121
406.5.6	FS18
407.12 (New)	F271
412.7.3	E28
413.2	F40
414.1.2.1	F293
414.2	F282
414.2.1	F282

414.2.2	F282
414.2.3	F288
Table 414.2.5(1)	F289
Table 414.2.5(2)	F40
414.2.5.3	F293
Table 414.5.1	F168, F169, F203
Table 415.6.2	F287
415.8.5	F40
415.11.2	F40
415.11.11	F40
415.11.11.1	F40
Table 415.11.1.1.1	F232
427.2	F282
427.2.2	F296
428.3.9	F14, F40
Chapter 5	
505.2.1	F40
506.2.2.1	F14
506.2.4.1	F14
510.2	F40
Chapter 6	
Table 601	FS9, FS18
Table 602	FS18
603.1	F10
Chapter 7	
704.4	G103
705.3	G54
707.4	E102
708.1	E25
708.4.1	E25
710.5.2.1 (New)	G42
712.1.7	G31
713.11	F40
713.13.6	F40
716.4 (New)	G34
716.4.1 (New)	G34
716.4.2 (New)	G34
716.4.3 (New)	G34
717.4	M72
Chapter 8	
801	F92 Part II
801.1	F92 Part II
801.2	G71
802.1	G71
802.3	F92 Part II
806.2	F40
807 (New)	F92 Part II
Chapter 9	See IFC Committee Chapter 9 for IBC Chapter 9

	Proposals
903.2.10.2	G39
Table 903.2.11.6	G39, G66
904.13	G40, G55
Chapter 10	
Table 1004.5	G15 Part II
1006.2.2.3	F40
1006.3.3	G38
1011.7	G95
Table 1017.2	G31, G48
1017.3	G31
1017.3.2.1 (New)	G31
1017.3.2.2 (New)	G31
1017.3.2.3 (New)	G31
1020.1	FS18
1023.2	G95
1028.1	F40, G31
1029.6.2.3	F40
Chapter 11	
1109.2.1.7	P22 Part I
Chapter 12	
1202.1	M15 Part II
1203.4	F14
Chapter 15	
1509	FS154
1509.1	FS154
1509.2	FS154
1509.3	FS154
1509.4	FS154
1510.4	FS18
Chapter 16	
Table 1607.1	G16, FS153
1607.13.3	FS153
Chapter 17	
1705.12.6	F14
1705.17	FS53
Chapter 21	
2103.1	FS18
Chapter 23	
2304.11.3	G109
2304.11.4	G109
Chapter 26	
2603.3	F14, F40

2606.7.4	F14
Chapter 27	
2702.1.2	F196
2702.2.3	F45
2702.2.4	F149
Chapter 29	
2902.1	P10
Table 2902.1	P13
2902.1.1	P15
2902.1.2	P15, P16
2902.1.3	P15
2902.2	P17
2902.3.2	P10
2902.3.3	P21
2902.3.6	P10
2902.3.7	P22 Part II
Chapter 30	
3008.6.4	E34
Chapter 31	
3103.3	FS18
3104.5.3	F14
Chapter 33	
3301.1	F262 Part II
3301.2	F262 Part II
3301.3	F262 Part II
3301.7	F262 Part II
3302.4(New)	E83
3309	F262 Part II
3310	F262 Part II
3311	F262 Part II
3311.3	F269
3312	F262 Part II
3312.1 (New)	F270
3313	F262 Part II
3313.1	F268
3313.2 (New)	F268
3313.3 (New)	F268
3313.3.1 (New)	F268
3313.3.2 (New)	F268
3313.3.3 (New)	F268
3313.4 (New)	F268
3313.5 (New)	F268
3314	F262 Part II
3314 (New)	F267 Part II
3315	F262 Part II
3316	F262 Part II
3322	F262 Part II
3323	F262 Part II

Appendix C	
C102.3	F40
INTERNATIONAL EXISTING BUILDING CODE	
Chapter 5	
504.5	F40
Chapter 8	
802.2.1	F40
803.1.1	F40
803.2.4	F123
805.3.1.2.1	F40
805.5.1	F40
Chapter 10	
1011.7.3	F40
Chapter 12	
1204.4	F40
Chapter 15	
1506.3	F269
1507.1	F270
1509.1	F268
1509.2 (New)	F268
1509.3 (New)	F268
1509.3.1 (New)	F268
1509.3.2 (New)	F268
1509.3.3 (New)	F268
1509.4 (New)	F268
1509.5 (New)	F268
INTERNATIONAL FIRE CODE	
Chapter 2	
Indoor Horticultural Grow Structure	G71
Mechanical-access Enclosed Parking Garage	G39
Chapter 3	
317	FS153
317.1	FS153
317.2	FS153
317.3	FS153
317.4.3	FS153
320	PM8 Part II
Chapter 5	
504.3	FS153
Chapter 8	

801.2	G71
802.1	G71
803.10	FS84
Chapter 9	
903.2.10.2	G39
Table 903.2.11.6	G39, G66
904.13	G40, G55
905.3.8	FS153
914.3.1.2	G28
914.7	G48
914.7.1	G48
914.7.2	G48
914.8.3	G23
Chapter 10	
See Egress Committee for Chapter 10 of the Fire Code	
1006.3.3	G38
1011.7	G95
Table 1017.2	G31, G48
1017.3	G31
1017.3.2.1 (New)	G31
1017.3.2.2 (New)	G31
1017.3.2.3 (New)	G31
1023.1	G95
1028.1	G31
1031.2.2	E48
Chapter 31	
3103.3.1	G48
INTERNATIONAL FUEL GAS CODE	
Chapter 2	
COPPER ALLOY	P1 Part IV
Chapter 3	
303.3.1	F122 Part II
INTERNATIONAL MECHANICAL CODE	
Chapter 2	
COPPER ALLOY	P1 Part III
FLAMMABILITY CLASSIFICATION	F79 Part II
FLAMMABILITY CLASSIFICATION (Refrigerant)	F79 Part II
REFRIGERENT CONCENTRAION LIMIT (Refrigerant) (RCL)	F79 Part II
REFRIGERENT SAFETY CLASSIFICATION	F79 Part II
REFRIGERANT SAFETY GROUP CLASSIFICATION	F79 Part II
TOXICITY CLASSIFICATION	F79 Part II
TOXICITY CLASSIFICATION (REFRIGERANT) (NEW)	F79 Part II

Chapter 3	
304.11	E83, E84
Chapter 4	
401.2	G116 Part II
401.2.1	G116 Part II
401.2.2	G116 Part II
Chapter 5	
502.9.5	F276
513.12.1	F160
Chapter 6	
606.4.1	F143
607.3.1	FS63, FS64
607.5.2	FS68, FS71,
607.5.3	FS71
607.5.5	FS70
Chapter 11	
1103.1	F79 Part II
Table 1103.1	F79 Part II
1105.10	E15 Part II
1106.4	F83 Part II
1106.5	F83 Part II
1106.5.1	F79 Part I, F83 Part I
1106.5.2	F79 Part II
Table 1106.5.2	F79 Part II
INTERNATIONAL PLUMBING CODE	
Chapter 3	
314.2.1.1 (New)	M11
314.2.2	M14
Chapter 6	
Table 608.1	F14 Part I
608.17.4	F14 Part I
608.17.4.1	F14 Part I
Chapter 12	
1202.2	F297 Part II
INTERNATIONAL PRIVATE SEWAGE DISPOSAL CODE	
Chapter 2	
Copper Alloy (New)	P1 Part VI
INTERNATIONAL PROPERTY MAINTENANCE CODE	
Chapter 2	
Emergency Escape and Rescue Opening (New)	G5 Part II
Chapter 4	
404.6	G130 Part II

Chapter 5	
503.3	P20 Part II
Chapter 7	
702.4	F181
INTERNATIONAL RESIDENTIAL CODE	
Chapter 2	
COPPER ALLOY	P1 Part II
HOT WATER	P58 Part II
PUSH-FIT FITTING (New)	P89 Part II
Chapter 3	
Chapter 14	
M1402.1	M86 Part II
Chapter 15	
M1502.4.5 (New)	M53 Part II
Chapter 16	
M1601.1.1	M78 Part II
Chapter 20	
M2006.1	M86 Part II
Chapter 21	
M2103.1	M119 Part II
Chapter 25	
P2503.5.1	P11 Part II
Chapter 26	
P2603.4 (New)	P8 Part II
P2605.1	P7 Part II
Chapter 27	
P2708.2.1 (New)	P63 Part II
P2708.4	P44 Part II, P45 Part II, P46 Part II
P2713.3	P44 Part II, P47 Part II, P48 Part II, P50 Part II
P2721.2	P33 Part II
Chapter 28	
P2802.1	P71 Part II
P2803.2	P71 Part II
Chapter 29	
Table P2902.3	P97 Part II
P2902.3.3	P97 Part II
P2902.5.1	P97 Part II

P2902.6.3	P98 Part II
P2903.1	P79 Part II
Table P2903.1	P79 Part II
Table P2903.2	P82 Part II
P2903.3.1	P77 Part II
Table P2906.6	P87 Part II
P2906.15	P88 Part II
P2906.21	P89 Part II
P2912.1.1	P131 Part II, P132 Part II
Chapter 30	
Table P3002.2	P103 Part II
Table P3002.3	P106 Part II , P109 Part II
P3003.3.4 (New)	P106 Part II
P3003.9.4	P109 Part II
P3005.2	P113 Part II
P3005.2.10.1 (New)	P113 Part II
P3009	P133 Part II
P3009.1	P133 Part II
P3009.2	P133 Part II
P3009.3	P133 Part II
P3009.4	P133 Part II
P3009.5	P133 Part II
P3009.6	P133 Part II
P3009.7	P133 Part II
P3009.8	P133 Part II
P3009.9	P133 Part II
Table P3009.9	P133 Part II
P3009.10	P133 Part II
P3011	P115 Part II
P3011.1	P115 Part II
P3011.2	P115 Part II
P3011.3	P115 Part II
P3011.4	P115 Part II
P3011.5	P115 Part II
P3011.6	P115 Part II
P3011.7	P115 Part II
P3011.7.1 (New)	P115 Part II
P3011.7.2 (New)	P115 Part II
P3011.8 (New)	P115 Part II
P3011.9 (New)	P115 Part II
P3011.10 (New)	P115 Part II
INTERNATIONAL SWIMMING POOL AND SPA CODE	
Chapter 2	
COPPER ALLOY	P1 Part V
ICC PERFORMANCE CODE	
A103.1.9.12	G48

2018 GROUP A COMMITTEE ACTION HEARING SCHEDULE

April 15 – 23, 2018

Greater Columbus Convention Center: Columbus, OH

The hearings will start at 1:00 pm on Sunday, April 15th. Prior to the hearings on Sunday morning, the Membership Councils and Major Jurisdictions Committee will be holding meetings. Following these meetings and prior to the hearings, a Members' Forum is scheduled. See [schedule](#).

Unless noted by "Start no earlier than X am/pm," each Code Committee will begin immediately upon completion of the hearings for the prior Committee. This includes moving a Committee forward or back from the day indicated based on hearing progress. The actual start times for the various Committees are not stipulated because of uncertainties in hearing progress. The schedule anticipates that the hearings will finish on the date noted as "Finish" for each track. This may require going beyond the scheduled finish time.

	Sunday April 15	Monday April 16	Tuesday April 17	Wednesday April 18	Thursday April 19
TRACK 1	Start 1 pm IPMC/IZC IBC - G End 7 pm	Start 8 am IBC - G End 7 pm	Start 8 am IBC - G IBC - FS (Start no earlier than 10 am) End 7 pm	Start 8 am IBC - FS End 7 pm	Start 8 am IBC - FS End 7 pm
TRACK 2	Start 1 pm ISPSC IFGC End 7 pm	Start 8 am IFGC IMC (Start no earlier than 8 am) End 7 pm	Start 8 am IMC IRC - M IRC - P End 7 pm	Start 8 am IRC - P IPC/IPSDC (Start no earlier than 10 am) End 7 pm	Start 8 am IPC End 7 pm

	Friday April 20	Saturday April 21	Sunday April 22	Monday April 23
TRACK 1	Start 8 am IBC - FS IBC - E (Start no earlier than 8 am) End 7 pm	Start 8 am IBC - E End 7 pm	Start 10 am IBC - E Finish 3 pm (See above)	
TRACK 2	Start 8 am IPC IFC/IWUIC (Start no earlier than 8 am) End 7 pm	Start 8 am IFC End 7 pm	Start 10 am IFC End 7 pm	Start 8 am IFC Finish 7 pm (See above)

SEE NEXT PAGE FOR SCHEDULE NOTES AND CODE COMMITTEE DESIGNATIONS

Notes:

- Code change agenda to be posted February 28th.
- Hearing times may be modified at the discretion of the Chairman based on hearing progress.
- Morning and afternoon breaks will be announced. A lunch break is planned for each track. A dinner break is not planned. The hearings are scheduled to adjourn for dinner and resume the next day, unless otherwise necessary to complete the agenda.
- Because of uncertainties in hearing progress, the start time indicated as “start no earlier than xx” is conservatively estimated and is not intended to be a hearing progress target.
- Consult the hearing order in the posted code change agenda for:
 - Code changes to be heard by a Committee other than the Committee under which the code change is designated.
 - Code changes comprised of multiple parts where each part is heard by a different Committee.
 - Code changes to the definitions to determine the applicable Committee who will hear the change to the definition for the respective code.
- There are no code change proposals submitted to the ICC Performance Code or the International Zoning Code.

Code Committees/Codes:

- IBC-E: International Building Code (IBC) Egress provisions. Chapters 10 and 11
- IBC-FS: IBC Fire Safety provisions. Chapters 7, 8, 9 (partial), 14 and 26. Majority of IBC Chapter 9 is maintained by the IFC
- IBC-G: IBC General provisions. Chapters 3 – 6, 12, 13, 27 – 33
- IFC/IWUIC: International Fire and Wildland-Urban Interface Codes
- IFGC: International Fuel Gas Code
- IMC: International Mechanical Code
- IPC/IPSDC: International Plumbing Code and Private Sewage Disposal Codes
- IPMC/IZC: International Property Maintenance and Zoning Codes
- IRC-M: International Residential Code (IRC) Mechanical provisions. Chapters 12 – 23 (code changes heard by the IRC - MP code committee)
- IRC-P: IRC Plumbing provisions. Chapters 25 – 33 (code changes heard by the IRC - MP code committee)
- ISPSC: International Swimming Pool and Spa Code

**2018 PROPOSED CHANGES
TO THE INTERNATIONAL**

<u>CODE</u>	<u>PAGE</u>
IBC – Egress	E1
IBC – Fire Safety	FS1
IBC – General	G1
IBC – Structural.....	S1
IFC	F1
IFGC.....	FG1
IMC	M1
IPC.....	P1
IPMC	PM1
IPSDC.....	PSD1
IRC – Building	RB1
IRC – Mechanical	RM1
IRC – Plumbing	RP1
ISPSC.....	SP1
IWUIC	WUIC1
CCC	CCC1

2018 GROUP A – PROPOSED CHANGES TO THE INTERNATIONAL BUILDING CODE – MEANS OF EGRESS

MEANS OF EGRESS CODE COMMITTEE

Jeffrey Tubbs, PE, Chair

Principal
Arup
Boston, MA

William D. (Bill) Dupler, Vice Chair

Deputy County Administrator- Community
Development
Chesterfield County VA
Chesterfield, VA

Matt Archer

Chief Building Official
City of Lone Tree
Lone Tree, CO

Matthew Bailey

Rep: National Association of Home Builders
Bailey Company
Rogersville, MO

Gene Boecker, AIA, RAS

Rep: National Association of Theatre Owners
Accessibility Project Manager
Code Consultants, Inc.
St. Louis, MO

William A. Brizee, AIA

Principal
Architects Hawaii
Honolulu, HI

Jeffrey S. Grove, P.E.

Director
Jensen Hughes
Las Vegas, NV

Lee Kranz, CBO

Plan Review Supervisor
City of Bellevue, WA
Bellevue, WA

Paul D. Martin

Rep: National Association of State Fire Marshals
Deputy State Fire Administrator
New York State Office of Fire Prevention and
Control
Albany, NY

Gregory N. Nicholls, AIA

Architect
The PREVIEW Group, Inc.
Cincinnati, OH

Carroll Lee Pruitt, FAIA

President/CEO
Pruitt Consulting, Inc.
Fort Worth, TX

Patrick Tomasino

State Building Official
State of UTAH
Salt Lake City, UT

Keith L. Wen, RA

Technical Advisor to the First Deputy
Commissioner
New York Department of Buildings
New York, NY

Dan Willham, RA

Deputy Building Official
County of Fairfax, Virginia
Fairfax, VA

Armin Wolski, PE

Principal
Reax Engineering
Berkeley, CA

Staff Secretariat:

Kimberly Paarlberg, RA

Senior Staff Architect
Codes and Standards Development
ICC Indiana Field Office
Carmel, IN

TENTATIVE ORDER OF DISCUSSION 2018 PROPOSED CHANGES TO THE INTERNATIONAL BUILDING CODE – EGRESS

The following is the tentative order in which the proposed changes to the code will be discussed at the public hearings. Proposed changes which impact the same subject have been grouped to permit consideration in consecutive changes.

Proposed change numbers that are indented are those which are being heard out of numerical order. Indentation does not necessarily indicate that one change is related to another. Proposed changes may be grouped for purposes of discussion at the hearing at the discretion of the chair. Note that some E code change proposals may not be included on this list, as they are being heard by another committee.

E1-18	E31-18	E72-18	G4-18
E2-18	E32-18	E100-18	G29-18
E3-18	E33-18	E73-18	E108-18
E4-18	E34-18	E74-18	E109-18
E5-18	E35-18	E75-18	E110-18
E6-18	E36-18	E76-18	E111-18
E7-18	E37-18	E77-18	E113-18
G15-28 Part 2	E38-18	E78-18	E112-18
E8-18	E39-18	E79-18	E114-18
E9-18	E40-18	E80-18	E115-18
E10-18	E41-18	E81-18	E116-18
E11-18	E42-18	E82-18	E117-18
E12-18	E43-18	E83-18	E118-18
E13-18	E44-18	E84-18	E119-18
E14-18	E45-18	E85-18	E120-18
E15-18 Part 1	E46-18	E86-18	E121-18
E16-18	E47-18	E87-18	E122-18
E17-18	E48-18	E88-18	E126-18
E63-18	E49-18	E89-18	E127-18
E64-18	E50-18	E90-18	E128-18
E65-18	E51-18	G43-18	E129-18
E18-18	E52-18	G44-18	E123-18
E22-18	E53-18	G45-18	E124-18
E29-18	E54-18	E91-18	E125-18
E30-18	E55-18	E92-18	E130-18
G31-18	E56-18	E93-18	E131-18
E19-18	E57-18	E94-18	E132-18
G35-18	E58-18	E95-18	E133-18
E96-18	E59-18	E98-18	E134-18
E20-18	E60-18	E99-18	E135-18
E21-18	E61-18	E101-18	E136-18
E23-18	E62-18	E102-18	E137-18
E24-18	E66-18	E103-18	
G38-18	E67-18	E104-18	
E25-18	E68-18	E105-18	
E26-18	E69-18	E106-18	
E27-18	E70-18	E107-18	
E28-18	E71-18	G5-18 Part 1	

E1-18

IBC: 1003.4, 1003.5, 1003.8 (New), (IFC[BE] 1003.4, 1003.5, 1003.8 (New))

Proponent: Jake Pauls, Jake Pauls Consulting Services, representing Jake Pauls Consulting Services (bldguse@aol.com)

2018 International Building Code

Revise as follows:

1003.4 Slip-resistant surface. Circulation paths of the *means of egress* shall have a slip-resistant surface and be securely attached.

Exception: Walking surfaces of showers and bathtubs not required to be accessible are not required to be slip-resistant where grab bars or stanchions complying with Section 1003.8 are provided.

1003.5 Elevation change. Where changes in elevation of less than 12 inches (305 mm) exist in the *means of egress*, sloped surfaces shall be used. Where the slope is greater than one unit vertical in 20 units horizontal (5-percent slope), *ramps* complying with Section 1012 shall be used. Where the difference in elevation is 6 inches (152 mm) or less, the *ramp* shall be equipped with either *handrails* or floor finish materials that contrast with adjacent floor finish materials.

Exceptions:

1. A single step with a maximum riser height of 7 inches (178 mm) is permitted for buildings with occupancies in Groups F, H, R-2, R-3, S and U at exterior doors not required to be *accessible* by Chapter 11.
2. A *stair* with a single riser or with two risers and a tread is permitted at locations not required to be *accessible* by Chapter 11 where the risers and treads comply with Section 1011.5, the minimum depth of the tread is 13 inches (330 mm) and not less than one *handrail* complying with Section 1014 is provided within 30 inches (762 mm) of the centerline of the normal path of egress travel on the *stair*.
3. A step is permitted in *aisles* serving seating that has a difference in elevation less than 12 inches (305 mm) at locations not required to be *accessible* by Chapter 11, provided that the risers and treads comply with Section 1029.14 and the *aisle* is provided with a *handrail* complying with Section 1029.16.
4. Bathtubs required to be accessible and bathtubs with grab bars or stanchions complying with Section 1003.8 are permitted to have step-over bathtub walls.
5. Showers, not required to be accessible are permitted to have curbs 6 inches (152 mm) high maximum where grab bars or stanchions complying with Section 1003.8 are provided.

Throughout a story in a Group I-2 occupancy, any change in elevation in portions of the *means of egress* that serve nonambulatory persons shall be by means of a *ramp* or sloped walkway.

Add new text as follows:

1003.8 Stanchions or Grab bars for Bathtubs, Bathtub-Shower Combinations and Showers.

1003.8.1 General. Bathtubs and bathtub-shower combinations not required to be accessible shall provide at least one stanchion complying with 1003.8.2 and one grab bar complying with Section 1003.8.3. Showers not required to be accessible shall provide at least one stanchion or grab bar complying with Section 1003.4. All stanchions and grab bars shall comply with Sections 1003.8.5 through 1003.8.7.

1003.8.2. Stanchion or Grab Bar. A vertical stanchion or grab bar complying with Sections 1003.8.2.1 through 1003.8.2.3 shall be provided.

1003.8.2.1 Approach. The stanchion or grab bar shall be located so that it is usable without any obstruction. An unobstructed clear floor space of 21 inches (535 mm) wide minimum and 21 inches (535 mm) deep minimum, measured from the tub wall shall be provided. The clear floor space shall be located outside the tub and be within 12 inches (305 mm) of the centerline of the stanchion or grab bar measured horizontally.

1003.8.2.2 Length. The stanchion or grab bar shall be 36 inches (914 mm) long minimum and shall extend to a height of 60 inches minimum above the finished floor or bathtub floor, as applicable.

1003.8.2.3 Position. The stanchion or grab bar shall be positioned in accordance with at least one of the following two options:

1. Stanchion or grab bar located inside the bathtub or combination bathtub-shower compartment. The space, measured horizontally from the centerline of the stanchion or grab bar shall be 12 inches (305 mm) maximum to the exterior wall of the bathtub and 6 inches (152 mm) minimum to a shower curtain rod.
2. Stanchion or grab bar located outside the bathtub or combination bathtub-shower compartment. The stanchion or grab bar shall be 6 inches (152 mm) maximum from the outer side of the bathtub wall, measured horizontally.

1003.8.3. Grab Bar. A 24-inch (610 mm) long minimum grab bar shall be provided on the non-entry (long) side of bathtubs and bathtub-shower combinations and shall be positioned in accordance with Sections 1003.8.3.1 or 1003.8.3.2.

1003.8.3.1 Horizontal Position. A grab bar shall be installed in a horizontal position and shall be centered, plus or minus two inches (51 mm), along the length of the bathtub. The grab bar shall be located 8 inches (205 mm) minimum and 10 inches (255 mm) maximum above the bathtub rim measured to the centerline of the grab bar.

1003.8.3.2 Diagonal Position. A grab bar shall be installed in a diagonal position with its higher end 25 inches (635 mm) high minimum and 27 inches (685 mm) high maximum above the bathtub rim. The higher end shall be located no more than 12 inches (305 mm) from the control wall measured horizontally. The lower end shall be 8 inches (203 mm) high minimum and 10 inches high (255 mm) maximum above the bathtub rim.

1003.8.4 Showers. A stanchion or grab bar shall be provided, located either interior to or outside of the shower compartment, within 3 inches (76 mm) of the adjacent face of the opening. The stanchion or grab bar shall be 24 inches (610 mm) long minimum with its lower end 39 inches (991 mm) maximum above the finished floor.

1003.8.5 Other Details. Grab bars and stanchions shall comply with Section 1003.8.5.

1003.8.5.1 Cross Section. Grab bars and stanchions shall be circular in cross section having an outside diameter of 1-1/4 inches (32 mm) minimum and 2 inches (51 mm) maximum.

1003.8.5.2. Spacing. The space between the stanchion or grab bar and adjacent surfaces, including controls or other fixtures, shall be 1-1/2 inches (38 mm) wide minimum.

1003.8.5.3. Surface Hazards. Stanchions, grab bars, and adjacent surfaces shall be free of sharp or abrasive elements. Edges shall be rounded with a minimum radius of 0.25 inch (6 mm).

1003.8.6. Structural Characteristics. Allowable stresses shall not be exceeded for materials used when a vertical or horizontal force of 250 pounds (1112 N) is applied at any point on the grab bar, stanchion, fastener, mounting device, or supporting structure. Grab bars and stanchions shall not rotate within their fittings.

1003.8.7. Design and Installation for Water. Grab bars, stanchions, fasteners, mounting devices, and supporting structure shall be composed of materials and installed to withstand damaging effects of water, including corrosion and other deterioration through their service life.

Reason:

Reason Statement (Justification) for Grab Bars

for Bathtubs, Bathtub-Shower Combinations and Showers (Proposal ID: 1066)

Complying with New Requirements in IBC Section 1003

Proposed by Jake Pauls, BArch, CPE, HonDSc

Introduction

Points of Control. Grab bars, handrails and stanchions are important building components providing—in combination with our hands and our feet—what are called (in ergonomics) “points of control” to maintain balance and aid in ambulation and other movement activities that are crucial to utilizing means of egress for safety generally (in both normal and emergency conditions) and which pose dangers of injurious falls, the leading source of injuries in most countries, including the USA.

A brief digression to explain “stanchions.” You see them routinely on transportation vehicles such as subway trains and city buses. They are the vertical assemblies of graspable tubing that are fixed between ceilings, horizontal handrails just above head height, seats, floors, etc. usually located between seating and passageways or aisles. The term, stanchions is used in ADA requirements for transportation vehicles and for this context Wikipedia has the following description: “On board most buses and trams/subways, vertical supports to provide stability when passengers are standing. They are located throughout most city buses and are connected to seats, floor, roof, etc.” This term is used in contexts similar to those for the “poles” referred to in NFPA’s recent adoption of new requirements for grab bars or poles for new bathtubs, bathtub-shower combinations and showers.

Examples of Points of Control in Specific Contexts. The starred, central cell of Table 1. shows the equity, with points of control— shown in bold italics—achieved with now-proposed grab bars, handrails and stanchions being required, in Section 1003, in the same way that handrails are required for stairs in the rest of the IBC.

Table 1.

Minimum Number of Points of Control Provided with New (★) or Currently Imposed Rules or Practices

Number of Points of Control Via Hands or Feet	≤1	1	2	3	3-4
Standard walker for older adult with altered gait.					✓
Occupational settings with risk of worker falls from heights. Also, stairs where users can use two handrails simultaneously, one on each side.				✓	
Stairs where users have only a single handrail. <i>Grab bar(s) usable for bathtub/shower entry/egress.</i>			✓ ★		
Bathtubs/showers with slip resistant underfoot surfaces when wet.		✓			
Bathtubs/showers without slip resistant underfoot surfaces when wet, the common condition currently.	✓				

The Problems To Be Solved with A New Requirement for Grab Bars and Stanchions. The central and most important point of this code change proposal is to respond to the relatively high risk of injurious falls when entering and exiting bathing/showering facilities, in all new settings where they occur. Such risks exceed those for stairs on an exposure-adjusted basis. That is, the time during which one is stepping into or out of a bathtub or shower is more risky than a similar stepping behavior on a stair. The former result in about 25 percent of the injuries as do falls on stairs. This is based on about 300,000 US hospital emergency room visits per year for bathtubs and showers versus about 1.2 million US hospital emergency room visits per year for stairs, using comparably serious injury data for 2010 (discussed by Lawrence, et al., 2015 in the journal Injury Prevention). The societal cost of these injuries, plus about two and a half times additional, medically treated injuries, was (for 2010) about 20 billion dollars for US bathtubs and showers and about 93 billion dollars for US stairs with the greatest risk for both being in homes, where bathing/showering is a near daily activity for most people in the US (Lawrence, et al, 2015). (See also the annex to this justification for details of injuries documented by the US Consumer Product Safety Commission, CPSC.)

Table 1 depicts the current inequity as well as the increased equity that will be achieved when bathtubs and showers are subject to the same principle about availability of points of control (usable by ones hands or feet) that are crucial to our stability in utilizing those portions of the means of egress that entail elevation differences, changes of slope, and changes in slip resistance. The current—at best—one point of control provided with typical bathtubs and showers (i.e., one foot in a stable placement on a slip-resistant surface) would be augmented by one point of control available reliably to one hand. This achieves equity of safety with stairs where we can count on one foot planted on a tread and one hand on a handrail. For some situations, involving bathtubs used for immersion bathing (with occupants seated or lying on the bottom of the tub) two points of control, utilizing grab bars, or stanchions—one for each hand—are needed for this equity and, more practically, to accomplish the relatively difficult stand-to-sit and sit-to-stand transfers within the tub.

Size of the Problem with Bathtubs and Showers Compared to Other Large Problems. Figure 1, a pie chart, shows the approximate scales of the nonfatal injury problem for three dangers to building occupants. In the US, the traditional danger of fire-related injuries is far smaller than that from bathing/showering and even smaller in relation to stair-related injuries. Right now, in the I-Codes, the segment for bathing/showering is not addressed while many, many pages of the I-Codes deal with fire-related injury prevention. Again, the proposal for grab bars and other points of control to be provided equitably, will provide a major improvement to injury prevention that, heretofore, has been largely ignored in code development and in practice except in some hotel properties where no more than half of the grab bars or stanchions to be required under the new proposal are provided for bathtubs.

Figure 1.

Comparing three dangers resulting in injuries in buildings

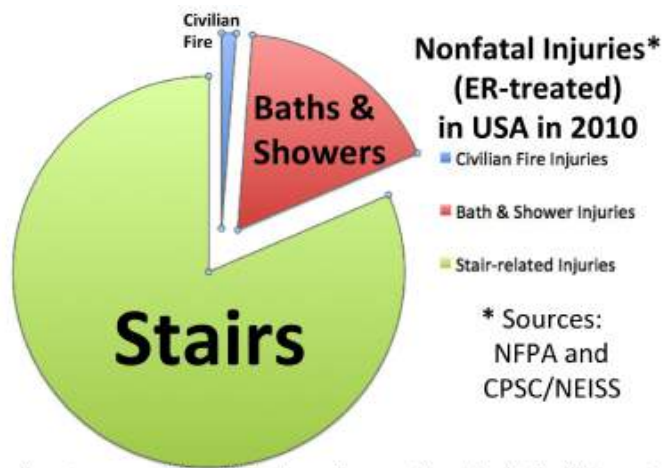

There is an inverse relationship between these epidemiological insights and the extent of coverage of the great dangers of stairs and baths/showers in building codes and housing codes plus leading healthy homes literature.

International Codes, Scientific/Technical/Policy/Managerial Perspectives Precedent Set by NFPA Codes. The foregoing is the philosophical and epidemiological foundation for the proposed addition of requirements for grab bars, and stanchions in Section 1003 of the IBC and, in future or elsewhere, in the I-Codes generally. There is also the precedent taken in NFPA 101 and NFPA 5000 in their 2018 editions where grab bars (alternatively poles which are given the more-technical name “stanchions” in this IBC proposal) were proposed and almost completely adopted (with the exception of health care, discussed below) for new bathtubs and showers in buildings regulated by these codes. The new requirements were mostly noncontroversial and it is hoped that the same will be true with the proposals now submitted to the I-Codes.

The justification for the new requirements far outweigh the opposition to them as the ergonomic, biomechanics, epidemiological, etiological and economic aspects have been carefully considered and addressed to the satisfaction of many people who know building codes and safety standards well and whose votes on the many committees considering the issue attest to the multiple justifications for this new feature of building codes and safety standards.

Parallel Code Development Activity in Canada. A proposal, comparable to what NFPA has adopted, is being addressed by a Grab Bar Task Group for the National Building Code of Canada and, when its next cycle commences, will also be proposed for action by the ICC A117 Committee for a new section, on mainstreamed grab bar and stanchion features for the A117.1 standard. Leaders in the standards and codes field, conversant with the value of grab bars and stanchions have been discussing such mainstreaming since early 2016, at an international meeting of experts on bathing/showering safety held in Toronto and partly available for study in a free streaming video that is available with several other streaming videos addressing points of control, grab bars, cost-benefit issues, etc., that are all listed in the Bibliography provided with this proposal. So a lot of the groundwork has been laid and different perspectives have been elicited and discussed.

Survey of Existing Facilities. Centered on hotels, health care facilities**, airport airline club shower facilities*, and homes, the proponent for this code change has been conducting a personal, opportunity-based survey of bathing/showering facilities worldwide, including the following countries where his work on building use and safety has taken him in recent years or his work is followed by other professionals, including public health authorities.

- Canada**
- USA* **
- UK*
- Sweden**
- Finland
- Netherlands
- Italy
- Singapore*
- Australia**
- New Zealand
- Japan

The survey is documented in many hours of video and thousands of photographs plus many measurements of three-

four-, five-piece bathrooms ranging in size from a few square meters (20 square feet) to spaces big enough to park an automobile, occasionally with tubs and showers almost that big. Generally, the more compact the bathroom, the easier it is to provide the needed points of control—and with very substantial cost savings.

Detailed Justifications for Specific New Sections in IBC 1003.

1003.4 Slip Resistant Surface. Showers and bathtubs are part of the means of egress for a building as they form part of the “occupied portion of a building.” However, recognizing reality, due to the presence of water on standing and walking surfaces in and around showers and bathtubs, it is almost certain that those surfaces are not slip-resistant and thus an exception is needed to cover them. Therefore countermeasures, in the form of grab bars or stanchions are needed to mitigate these serious slip-and-fall risks. Thus, via a new exception, this is one of two scoping requirements triggering the mandatory provision of grab bars or stanchions found in a new section, 1003.8.

1003.5 Elevation Change. Bathtubs and most showers have elevation changes with various step-over and step-on surfaces, often exceeding 5 percent in slope, that greatly heighten the risk of missteps (such as tripping as well as slipping) and loss of balance that can result in injurious falls that are exacerbated by the typically hard, often projecting surfaces that are especially unforgiving if fall-related impacts occur. Grab bars and other points of control, like stanchions, have both prevention and mitigation roles, for such missteps and falls, that parallel what handrails do for stairs to prevent and mitigate missteps and falls. Thus, via a new exception, this is the second of two scoping requirements triggering the mandatory provision of grab bars found in a new section, 1003.8 as is demonstrated in Figure 2.

Figure 2.

Demonstration set up of both conventional grab bars (nominally meeting the length and location criteria of proposed IBC Section 1008) and heavy duty tubing, both horizontal and vertical—that latter being a stanchion (completely meeting the length, location and structural strength requirements of proposed IBC Section 1008)



1003.8.1 General. This sets out the scoping for the new section. In Figure 2, the photograph shows a demonstration bathtub-shower combination with a redundant set of both conventional (vertical and diagonal) grab bars and a vertical, floor-to-ceiling pole—technically termed a stanchion, the latter easily meeting the 250-pound structural load criterion. So does the full-length horizontal bar (a tube) at the back of the bathtub.

Section 1003.8.1 sets up a structure for the requirements; first addressed in 1003.8.2 for bathtubs and bathtub-shower combinations which require a vertical point of control for ambulatory entry to and egress from the bathtub that typically involves stepping over the bathtub wall and dealing with different, perhaps wet surfaces inside the tub and on the floor outside the tub. For some tubs there will also be an elevation difference between the tub bottom and the floor outside the tub that can be an additional danger. These are important ergonomic or biomechanics considerations for

reasonably safe bathing and showering that will significantly reduce the large toll of falls and other injury events involving bathtubs and showers (as described for a few hundred cases in the Annexes accompanying this Reason statement).

Addressed second in 1003.8.1 is the need for a horizontal or diagonal point of control on the non-egress side of a bathtub that is covered by 1003.8.3. This addresses the need for a point of control that assists people who want to sit or lie down in the tub and have an immersion bath. This involves stand-to-sit and sit-to-stand transfers that will be facilitated with the bilateral support provided, on one side, by the vertical grab bar or stanchion required by 1003.8.2, on the other side, used in conjunction with the horizontal or diagonal grab bar required by 1003.8.3.

Addressed third in 1003.8.1 is ambulatory access into and egress from a stand-alone shower (not combined with a bathtub) addressed in 1003.8.4. While step-over heights are smaller than for bathtubs, there are still dangers in smaller heights of curbs needed for water control as well as in different elevations of the shower pan and the floor outside the shower. Again, a vertical point of control assists with such transfers.

The final scoping feature in 1003.8.1 is its reference to several details of the grab bars or stanchions dealing with their graspability, surroundings, structural characteristics, and long-term serviceability in the wet environment typical for baths and, more so, for showers.

1003.8.2. Stanchion or Grab Bar. This introduces the provision, approach, length, and position requirements for the required vertical point of control, a stanchion or a conventional, wall-mounted grab bar for bathtubs. Vertical grab bars were found to be especially useful in studies performed over the last two decades in Canada. (Bibliography: Items # 5, 23, 24, 29, 30 plus two reports, from 2017, by Novak & King and King & Novak.)

1003.8.2.1 Approach. The unobstructed clear floor space of 21 inches (535 mm) wide minimum and 21 inches (535 mm) deep minimum, measured from the tub wall, is based on the current space requirements of Section R307, including Figure R307, in the International Residential Code. Along with the 12-inch (305 mm) maximum horizontal distance between the point of control and the edge of the clear floor space, this provides reachability to the grab bar or stanchion for a user approaching, or stepping from a bathtub in a bathroom where there are other fixtures such as a water closet or lavatory.

1003.8.2.2 Length. The minimum length of 36 inches (914 mm) for the vertical grab bar or stanchion and minimum height of 60 inches serves ambulatory transfers by adults and children and provides a vertical point of control that extends low enough to serve bathers (children as well as adults) sitting or crouching in the bathtub.

1003.8.2.3 Position. The two options cover vertical, conventional, wall-mounted grab bars as well as stanchions (secured in place between, for example, the ceiling and the floor or the rim (top) of the tub wall) that can be located anywhere as they are not fastened to a wall, which for this requirement usually means one of the two end walls (control end wall and had end wall) for many bathtubs. (See Figure 2 above.) Note that, for option 1, a grab bar on an end wall, there is an important requirement to keep the grab bar at least 6 inches (horizontally) from shower curtain attachments so that there is no interference, from a grab bar, to the sealing of a shower curtain against a wall to prevent water from a shower getting on the floor outside the bathtub. Note that option 2 permits placing a stanchion outside the bathtub, within six inches of the outside bathtub wall; such a stanchion can serve stand-to-sit and sit-to-stand transfer functions for users of a water closet adjacent to the bathtub (as shown in Figure 2). This is a bonus benefit of such stanchions which, in this proposal, are already sufficiently justified for the bathing and showering functions alone. Such a benefit (for many users) will be gained several times a day, as opposed to once per day for a shower or bath and the value of such secondary benefits—to usability and safety. This dual use benefit should be considered in doing a cost impact analysis. The benefit is especially important for older users who are the most impacted, in terms of serious injuries requiring hospital admission, and for whom toileting is essential, unlike showering or bathing which can be avoided more often.

1003.8.3. Grab Bar. This addresses the need for a point of control, on the non-egress, long side side of the bathtub where there is usually a wall (except in the case of a free-standing tub. This assists people, after they have stepped into the tub and who want to sit or lie down in the tub for an immersion bath. Note that while useful for stand-to-sit and sit-to-stand transfers, this horizontal or diagonal point of control will not be very useful for ambulatory transfers to and from a bathtub as a person has to lean precariously, threatening balance, over the width of the tub to reach the point of control on the non-egress side. Such transfers rely on the vertical point of control required by 1003.8.2.

1003.8.3.1. This does not limit compliance to a conventional wall-mounted grab bar. See Figure 2 for a nonconventional point of control, in effect a stanchion, in a horizontal orientation, secured by end walls, and extending the full length of the bathtub thus providing extra usability to bathers (as well as serving as a longer rack for towels, laundry, etc.). For free-standing tubs, with no adjacent walls, the requirements permit other solutions for the horizontal grab bar, for example, a conventional grab bar mounted on a surround often provided for most new stand-alone tubs.

1003.8.3.2 Diagonal Position. The stated dimensions for this diagonal grab bar will result in an approximate 45-degree inclination of this point of control that combines versatility with height as well as horizontal reach. Of all of the point-of-control positioning options, this one will almost invariably require a backing wall and this one places the

greatest demand on structural backing—in terms of its size in the wall—for the fastening, typically with screws, of conventional grab bars. Keep in mind that the diagonal grab bar is an option and there are less-costly ways of complying with 1003.8.3.

1003.8.4 Showers. The requirement is intended to serve entering and egressing users regardless of whether the point of control is located inside or outside the shower enclosure or compartment. For example, fixing a point of control inside a shower is often problematic due to the nature of shower enclosures/compartment and of shower pans, both of which are subject to important waterproofing requirements. Here a stanchion, fastened to the room floor and ceiling and located just outside the entrance to a shower can be a good solution. This is especially true for increasingly used fixed, sliding or pivoting glass screens, for water control (in place of a shower curtain) on the open side of showers. The floor and ceiling take the usage loads on the stanchion whereas a conventional grab bar relies on a wall or wall-like feature.

1003.8.5 Other Details. Related mostly to effective and safe graspability with one or both hands, these are largely based on requirements of ICC A117.1.

1003.8.5.1 Cross Section. Unlike ICC A117.1 only circular is addressed. This reflects the overwhelming provision of circular-section grab bars and stanchions in practice. Anyone wanting more flexibility with cross section could introduce, via an amendment to the proposal, a separate provision for noncircular sections also complying with ICC A117.1. The rationale for not including noncircular sections here is the overwhelming advantage of circular sections for hand approach from any direction, an important aspect of the more varied uses of points of control for bathing and showering facilities than is the case for handrails for stairs. Also, even for stairs, a large proportion of the railings installed—of decorative rather than reasonably functional, circular cross section—do not function sufficiently well for even the more-limited biomechanics of stair handrail use.

1003.8.5.2. Spacing. The 1.5 inches (38 mm) wide minimum space might not be adequate with some plumbing controls (e.g., water temperature), but it is a good starting point for adequate clearance.

1003.8.5.3. Surface Hazards. Impact against surfaces, including controls and spouts, in bathing and showering facilities is a major source injuries and the requirement are justified.

1003.8.6. Structural Characteristics. The minimum vertical or horizontal force of 250 pounds (1112 N)—applied at any point on the grab bar, stanchion, fastener, mounting device, or supporting structure—is commonly used in the US. There is a need for this to be maintained and confirmed through the life of the grab bars. (Canada has a somewhat higher load requirement, 290 pounds). The requirement that points of control will not rotate within their fittings is reasonable as it increases the effectiveness of a user’s grasp and the users’ stability generally.

1003.8.7. Design and Installation for Water. This is a relatively new requirement but it is very much needed, based on the proponent’s checking of fixing quality of many grab bars in hotels around the world. Many grab bars are not designed, installed and maintained for water! Water might not only corrode the critical attachment screws of conventional, wall-mounted grab bars; water also causes deterioration of the backing materials for some badly installed and maintained grab bars. This one, relatively new requirement warrants extra explanation—which follows here.

Problems Found in the Field with Conventional Grab Bars

During the course of his opportunity-based survey of grab bars provided for bathrooms in hotel guest rooms, the proponent of this code change has found two problems with many installations.

The first, affecting over 50 percent of the surveyed bathtub-shower combinations in hotels, comes from placement of vertical grab bars underneath—and within a few inches horizontally of the end bracket for shower curtains. This makes sealing the shower curtain against the end wall of the bathtub-shower combination very difficult so that the danger of water getting outside the bathtub, on the adjacent floor is heightened unreasonably and needlessly. The proposed section 1003.8.2.1 addresses this problem in its last sentence, “Such grab bar shall be located a maximum of 12 inches (305 mm), measured horizontally, inside of the exterior approach side of the bathtub or bathtub-shower combination and no closer than 6 inches (150 mm), measured horizontally, to the end fixing of any shower curtain rod.”

A much more worrying problem is found with a smaller percentage of conventional, wall-mounted grab bar installations, specifically grab bars which have cover plates over the screw plate onto which the tube of the grab bar is welded. There is invariably a space between the hole in the cover plate through which the tubing (grasped) portion of the grab bar passes and the tubing itself. Water can easily enter here and get trapped by the cover plate thus creating a pool of water and debris (hair, shampoo residue, etc.) from the showering process. Figure 3 provides an example photographed on the wall of a bathtub-shower combination in a hotel guest bathroom.

Figure 3. Corrosion behind grab bar cover plate



Aside from the hygiene problem here, there is a greatly heightened risk of two structural problems. One is water intrusion into the wall, around the fixing screws—typically two or three for each end of the grab bar, causing deterioration of the backing material so the screws become loose enough to be extractable with ones fingers. The second problem is equally worrisome, especially as the quality of the steel used in (off-shore) grab bars is relatively poor in terms of corrosion of the screws and, less often, the mounting plates. The worst case seen recently had the heads of all the screws holding a grab bar so corroded that their heads were completely deteriorated and the grab bar could be pulled away from the walls with little force by one hand—clearly far, far less than the stipulated load of 250 pounds that codes in the US stipulate for structural strength. The proponent has many photographs of these problems as well as a few videos showing how loose the grab bars have become due to corrosion as well as backing deterioration from water. One such photograph is provided in Figure 3; it is not the worst situation seen in the field.

Clearly such examples need to be addressed in several ways including stronger inspection by authorities and improved management of facilities. Improved design and manufacture of conventional grab bars would help too but, until that occurs, this proposal offers the pole options as well as mounting locations that keep the important “points of control” in relatively dry locations—for example at the exterior of a shower enclosure or outside of a shower curtain for tubs and showers—but still near enough to the entrance to be usable from both outside and inside the space where water sprays, deflects and flows freely.

Annexes

Annex 1: Representative sample of narratives of actual bathtub/shower-related injuries that led to US hospital emergency room (ER) visits and, for about one in ten of such visits, also led to hospital admission covered by **Annex 2**, (plus an additional 30 percent who went directly to hospital admission without an ER visit) in 2010. These are collected and published by the US Consumer Product Safety Commission (CPSC) National Electronic Injury Surveillance System (NEISS) and many more can be downloaded from the CPSC/NEISS Web site, <https://www.cpsc.gov/Research--Statistics/NEISS-Injury-Data>. Accessed January 8, 2018.

Annex 1: US CPSC NEISS: First 112 Sample Narratives (of 6,946 cases) for Product Code 0611 Injuries in 2010 - ER released w/wo treatment (Product Code 611 covers bathtubs or showers including fixtures or accessories; excluding enclosures, faucets, spigots and towel racks)

41 YOM FRACTURED A RIB BY SLIPPING IN THE BATHTUB & FALLING AGAINST THE TOILET AT HOME.

53 YOF SUSTAINED A CONTUSION OF A SHIN BY BUMPING IT WHILE SHOWERING AT HOME.

18 YOF SPRAINED HER LOWER BACK BY FALLING IN THE SHOWER AT SCHOOL.

02 YOF SUSTAINED A LACERATION OF THE CHIN BY FALLING IN THE BATHTUB AT HOME.

18 YOF SUSTAINED A HEAD INJURY BY FALLING IN A SHOWER AT HOME.

80 YOM DISLOCATED A HIP BY LIFTING LEG IN SHOWER.

86 YOF SUSTAINED A LACERATION OF THE SCALP BY TRIPPING ON A RUG IN THE SHOWER AT HOME.

71 YOF SUSTAINED A HEAD INJURY BY FALLING FROM TOILET AGAINST THE BATHTUB AT HOME.

68 YOF SPRAINED AN ANKLE BY FALLING IN A SHOWER.

47 YOF FRACTURED A KNEE BY FALLING IN THE SHOWER AT HOME.

02 YOF SUSTAINED A LACERATION OF THE CHIN BY FALLING IN THE BATHTUB.

22 YOM SPRAINED A FOOT WHILE STEPPING OUT OF A SHOWER AT JAIL.

23 YOF SUSTAINED A CONTUSION OF A FOOT BY TRIPPING ON A RUG & STRIKING AGAINST A TUB AT HOME.

40 YOM SUSTAINED A LACERATION OF THE NOSE FROM BEING STRUCK BY THE SHOWER HEAD IN THE SHOWER AT HOME.

21 MOM RUPTURED AN EAR DRUM WITH A COTTON-TIPPED SWAB WHILE BATHING IN TUB AT HOME.

48 YOF SUSTAINED A CONTUSION OF THE NECK BY FALLING IN THE BATHTUB AT HOME.

04 YOF SLIPPED IN BATHTUB FELL AND INJURED FACE DX/ FACIAL LAC L KNEE STR

10 YOF FELL OUT OF SHOWER AND INJURED L KNEE. HAS ABRASION TO KNEE ALSO

80 YOF FELL IN SHOWER AT HOME HIT HEAD. DX/ HEAD INJURY

94 YOM SLIPPED AND FELL IN SHOWER AND HIT FACE ON FLOOR. DX/ FACIAL FX

55 YOM SLL LEG HEMATOMA

72 YOF CAUGHT FOOT IN TUB, INJURING LOWER LEG. NOW HAS HEMATOMA AND INCREASING PAIN.

22 YOF AT HOME FAINTED WHILE IN SHOWER AND FELL CUTTING FOREHEAD.

26 YOF SLIPPED AND FELL IN TUB DX: KNEE STRAIN

90 YOF GETTING OUT OF SHOWER WITH WALKER SLIPPED ON THE FLOOR AND HIT HEAD DX/ SCALP ABRASION

30 YOM SLIPPED AND FELL INTO TUB DX: CONTUSION TO BACK

51 YOF SLIPPED IN TUB AND HIT HEAD DX/ SCALP LAC

60 YOF SLIPPED AND FELL IN TUB DX: CONTUSION TO COCCYX

44 YOM FELL AND HIT ABDOMEN ON BATHTUB AT HOME. DX/ ABDOMINAL CONTUSION

04 YOM WITH CUT TO FACE FELL IN TUB DX: LACERATION TO FACE

51 YOF AT HOME FELL AT 5PM WHEN LOST BALANCE AND HIT L SIDE OF RIBS ON BATHTUB.

33 YOF SLIPPED AND FELL IN TUB DX: HEAD LACERATION

23 MOM FELL IN BATHTUB AT HOME AND HIT CHIN CAUSING LACERATION.

62 YOM WITH BACK PAIN FELL INTO TUB DX; CONTUSION TO LOWER BACK

63 YOF FELL INTO BATHTUB / NO INJURIES OR COMPLAINTS

54 YOM SLIPPED AND FELL IN TUB DX: RIB FRACTURE

02 YOM SLIPPED IN TUB AT HOME AND INJURED FACE DX/ CHIN LAC

25 YOF WITH CHEST PAIN AFTER FALL INTO TUB DX: CONTUSION TO CHEST

84 YOM FELL OUT OF SHOWER ON TO THE FLOOR AT HOME HIT HEAD DX/ HEAD INJURY

85 YOF SLIPPED AND FELL IN TUB AND HIT HEAD AT HOME DX/ HEAD INJURY

06 YOM AT HM WAS TAKING A BATH & SWIMMING IN TUB WHEN HE STRUCK HIS HEAD AGAINST FAUCET CAUSING HEAD LACERATION.

28 YOM AT HOME FELL IN SHOWER. WAS RESPONSIVE PER EMS.

26 YOF SLIPPED / FELL IN THE SHOWER DX: R EAR LAC. / HEAD & R SHOULDER CONTUSION

36 YOF THIS AM SLIPPED WHILE TRYING TO GET OUT OF BATHTUB AND LANDED ON BUTTOCKS.

28 YOF RIPPED FINGER NAIL OFF WHEN SLIPPED IN THE SHOWER AND THE NAIL BENT BACKWARDS.

26 YOF INJURED KNEE STEPPING OUT OF SHOWER DX/ RIGHT KNEE SPRAIN

50 YOM FELL IN BATHTUB AND HIT CHEST DX/ RIB FX

83 YOM CUT SCROTUM FELL IN TUB DX: LACERATION TO SCROTUM

71 YOF FELL OUT OF BATHTUB AT HOME AND HIT HEAD ON THE FLOOR DX/ HEAD INJURY

89 YOF FELL IN TUB HITTING HEAD DX: CLOSED HEAD INJURY
69 YOF WAS IN SHOWER AND FELL BACKWARDS STRIKING HER BACK.
08 YOF AT HOME LACERATED FACE ABOVE R ORBITAL. HIT HER HEAD ON SOAP DISH WHILE SHOWERING. NO LOC.
40 YOM SLIPPED AND FELL IN SHOWER AND INJURED CHEST. DX/ RIB FX
17 YOF FELL IN TUB HURT NECK DX: NECK STRAIN
23 YOM INJURED LOWER BACK BENDING OVER IN SHOWER AT HOME DX/ LUMBAR STRAIN
83 YOF FELL IN THE TUB AT ASSISTED LIVING AND INJURED SHOULDER DX/ RT SHOULDER CONTUSION
02 YOM HIT FACE ON BATHTUB AT HOME DX/ FACIAL LAC
74 YOM FELL AND HIT HEAD IN TUB DX: CONTUSION TO HEAD
85 YOF SLIPPED AND FELL GETTING OUT OF TUB DX: CONTUSION TO HIP
58 YOF SLIPPED AND FELL INTO TUB HIT HEAD DX: CLOSED HEAD INJURY
13 MOM AT HOME FELL IN BATHTUB AND HIT FOREHEAD AND MOUTH.
06 YOM SLIPPED IN BATHTUB AND HIT HEAD DX/ HEAD CONTUSION
78 YOM SLIPPED AND FELL IN TUB DX: LACERATION TO HEAD
08 YOM SLIPPED IN TUB TWISTED ANKLE DX: ANKLE STRAIN
51 YOF HIT HEAD ON SOAP DISH IN SHOWER 2 TIMES THIS WEEK HAS HEADACHE DX/ CONCUSSION
51 YOF SLIPPED IN SHOWER AND INJURED KNEE AT HOME DX/ RIGHT KNEE CONTUSION
83 YOM SLIPPED AND FELL IN THE SHOWER LAST NIGHT AND INJURED BACK DX/ BACK PAIN
31 YOM HIT EYE WITH TOWEL WHILE GETTING OUT OF THE SHOWER AT HOME DX/ RIGHT EYE CORNEAL ABRASION
24 YOF FELL GETTING OUT OF SHOWER HIT HEAD DX/ SCALP LAC
48 YOF SLIPPED IN SHOWER HIT HEAD + LOC DX/ HEAD INJURY
11 YOM SLIPPED IN SHOWER AND INJURED LEG. DX/ LEFT LEG CONTUSION
30 YOF SLIPPED AND FELL INTO TUB DX: CONTUSION TO HIP
18 MOM FELL IN TUB DX: LACERATION TO FACE
46 YOF SLIPPED AND FELL IN TUB DX: CONTUSION TO LOWER BACK
30 YOM CUT HAND ON BROKEN SOAP DISH AT HOME. DX// RIGHT HAND LAC
70 YOF SLIPPED AND FELL IN TUB DX: CONTUSION TO CHEST
31 YOM CUT THUMB ON SHOWER DRAIN THIS AM.
62 YOF SLIPPED IN THE SHOWER AND FELL ON THE FLOOR AT HOME DX/ LEFT WRIST SPRAIN
67 YOM FELL GETTING OUT OF SHOWER HIT HEAD ON TUB AT HOME DX/ SCALP CONTUSION
45 YOF PASSED OUT IN SHOWER AT GROUP HOME HIT HEAD. DX/ HEAD INJURY
04 YOF FELL IN BATHTUB AND HIT MOUTH DX/ LIP LAC
43 YOM SLIPPED IN BATHTUB AND INJURED KNEE DX/ LEFT KNEE CONTUSION
15 YOM TAKING SHOWER AND SHOWER DOOR SHATTERED AND PT FEET WERE CUT WITH THE GLASS AT HOME DX/ BILAT
FOOT LAC
73 YOF AT 9AM TODAY WAS GETTING OUT OF TUB AND SLIPPED AND BUMPED L RIBS ON THE TUB. C/O RIB PAIN.
87 YOF BENT DOWN TO PUT SCALE AWAY FELL AND HIT INTO TUB AT HOME DX/ LEFT HIP CONTUSION22 YOM FELL IN TUB
AT HOME AND INJURED CHEST DX/ RIB FX
40 YOF SLIPPED GETTING OUT OF BATHTUB AND INJURED LOWER BACK DX/ LOW BACK PAIN
34 YOM FELL AND HIT TUB DX: SHOULDER STRAIN
70 YOF SLIPPED FELL HIT CHEST ON SIDE OF TUB DX: CONTUSION TO CHEST
89 YOF SLIPPED AND FELL IN THE SHOWER LAST NIGHT AT NURSING HOME INJURED CHEST DX/ CHEST CONTUSION
44 YOM FELL IN TUB AND HIT CHEST DX.CHEST CONTUSION
36 YOF SLIPPED AND FELL IN TUB DX: LACERATION TO FACE
56 YOM CUT WRIST ON BROKEN SHOWER KNOB AT HOME DX/ LEFT WRIST LAC

88 YOF FELL AT HOME IN SHOWER AND HIT HEAD ON TUB DX/ SCALP CONTUSION
51 YOM SLIPPED AND FELL IN TUB DX: NECK STRAIN
23 YOM FELL IN BATH TUB AND INJURED CHEST DX/ CHEST CONTUSION
59 YOM FELL IN SHOWER AND INJURED SHOULDER DX/ LEFT SHOULDER FX
46 YOM HAD FALL HIT TUB DX: CONTUSION TO FACE
78 YOF FELL AT HOME AND HIT FACE ON BATHTUB DX/ FACIAL CONTUSION
29YOF WITH BACK PAIN AFTER FALL IN TUB DX: LOW BACK STRAIN
31 YOF FELL GETTING OUT OF TUB AT HOME INJURED FLANK DX/ FLANK CONTUSION
72 YOF AT HOME FELL WHEN SLIPPED ON URINE IN BATHROOM AND HIT HEAD ON SIDE OF BATH TUB.
19 YOF SLIPPED AND FELL INTO TUB DX: CONTUSION TO LOWER BACK
08 YOM FELL IN THE SHOWER AT HOME AND HIT EAR DX/ LEFT EAR LAC
62 YOM SLIPPED / FELL IN THE SHOWER. DX: RIB CONTUSION
09 YOF FELL IN TUB AND HIT LIP. DX/ LIP LAC
56 YOF WITH SHOULDER PAIN AFTER USING BATHBRUSH IN SHOWER DX: SHOULDER STRAIN
75 YOF AT HOME FELL OFF HASSOCK APPROX 30 MIN AGO HITTING HEAD AND L ARM ON BATHTUB. DENIES LOC.
62 YOF SLIPPED IN TUB HITTING FOOT DX: CONTUSION TO FOOT
04 YOM SLIPPED IN THE BATHTUB AND HIT CHIN DX/ CHIN LAC
34 YOM FELL IN THE SHOWER AT HOME INJURED BACK DX/ BACK SPRAIN
25 YOF + ETOH BAL 313 FELL IN SHOWER AND HIT HEAD DX/ HEAD CONTUSION

Annex 2: US CPSC NEISS: First 48 Sample Narratives (of 630 cases) for Product Code 0611 Injuries in 2010 - ER treated & Then Admitted to Hospital (Product Code 611 covers bathtubs or showers including fixtures or accessories; excluding enclosures, faucets, spigots and towel racks)

89 YOF GETTING OUT OF THE SHOWER THE NEXT THING SHE KNEW SHE WAS ON THE FLOOR WITH HEAD AND SHOULDER INJURY; SHOULDER AND HEAD CONTUSION
69 YOM WAS WASHING HIMSELF IN SHOWER, FELL ONTO BLUNT PART OF BATHTUB, IMMEDIATELY HAD PAIN & TROUBLE BREATHING. DX - MULTIPLE RIB FXS
56 YOF SLIPPED IN THE SHOWER AND FELL FORWARD HITTING HER FACE & INJURING HER RT ARM- DX- MECHANICAL FALL W/ FRACTURE RT SHOULDER
78 YOF FAMILY FOUND HER ON THE FLOOR BETWEEN TOILET AND BATHTUB, SHE STATED SHE PASSED OUT WHEN SHE WAS IN SHOWER; SHOULDER INJURY
47 YOM HAD A WET SHEETROCK FALL ON HEAD WHILE IN SHOWER, +LOC, WAS CONFUSED. DX - BLUNT HEAD TRAUMA W/BRIEF LOC
62 YOM HAD A SYNCOPAL TODAY AT HOME IN THE SHOWER INJURING EYE AREA- DX- LACERATION TO FACE(EYE)
78 YOF PRESENT TO ER FROM HOME WHEN SHE WAS TAKING A BATH AND COLLAPSED - DX- CARDIAC ARREST, RESUSCITAED
43 YOM PRESENT TO ER AFTER HE WAS IN THE BATHTUB AND SLIP AND FELL GETTING OUT HITTING HEAD ON FLOOR- DX- BLUNT HEAD TRAUMA
81 YOM PRESENT TO ER AFTER A FALL IN THE SHOWER AT HOME TODAY INJURING THE HEAD AREA- DX- BLUNT HEAD TRAUMA
41 YOM FELL OUT OF SHOWER AT ASSISTED LIVING HOME YESTERDAY ONTO RT SIDE C/O RT HIP & RT LEG PAIN. DX - RT HIP FRACTURE
80 YOF TRYING TO GET OUT OF BATHTUB ACCIDENTLY FELL INJURED LOWER BACK; BACK CONTUSION AND AMBULATORY DYSFUNCTION
92 YOM PRESENT TO ER AFTER A FALL IN BATHTUB THIS MORNING INJURING RT HIP-DX- FRACTURE RT LOWER TRUNK (HIP)
88 YOF PRESENT TO ER AFTER A FAL IN BATH TUB AT SNF INJURING LT HIP- DX - FRACTURE LT LOWER TRUNK (HIP)
88 YOF WAS GETTING OUT OF SHOWER, FELT DIZZY & FELL STRIKING BACK OF HEAD ON FLOOR INJURING LT ARM. DX - SKIN TEAR LACERATION

88 YOF GETTING OUT OF BATHTUB THIS MORNING FELL TRIED TO BRACE HERSELF INJURED SHOULDER; SHOULDER FRACTURE

71 YOF WAS FOUND DOWN BY SON IN BATHTUB AT HOME, HAS INJURY TO LT EYE & FOREHEAD, IS REPETITIVE. DX - BLUNT HEAD TRAUMA, +ETOH

86 YOF LOST BALANCE WHEN SHE TURNED AROUND & FELL INTO BATHTUB C/O LOW BACK PAIN. DX - LOW BACK PAIN, POSS FX VS CONTUSION

80 YOF HUSBAND DID NOT WANT HER SMOKING IN HOUSE, WENT TO BATHROOM STOOD ON THE TOILET, OPENED WINDOW, SLIPPED BETWN TOILET/TUB; PELVIC FX

44 YOF FELL IN SHOWER TODAY SUSTAINING HEAD INJURY. DX - SCALP LACERATION

37 YOF SUSTAINED A MECHANICAL FALL IN SHOWER ONTO RT UPPER EXTREMITY, C/O RT SHOULDER PAIN. DX - RT DISTAL CLAVICLE FX

37 YOM HAD A GROUND LEVEL FALL IN BATHROOM STRIKING LOWER BACK ON BATHTUB. DX - SPINAL CONTUSION

84 YOF HAD SYNCOPAL EPISODE IN SHOWER AND FELL. DX: L 10TH RIB FX, INABILITY TO AMBULATE.

87 YOF FELL IN SHOWER. DX: RHABDOMYOLYSIS.

93 YOF FELL IN SHOWER AT ASSISTED LIVING. DX: L DISTAL HUMERUS FX.

79 YOM FELL IN SHOWER. DX: A FIB W/RAPID VENTRICULAR RESP, SYNCOPE, SDH, SAH, ELEVATED INR.

84 YOF FELL WHILE GETTING OUT OF BATHTUB SUSTAINING A FRACTURE TO HER LUMBAR SPINE

90 YOF SLIPPED IN BATHTUB AND GRAZED HEAD ON SHELF AT ASSISTED LIVING. DX: R KNEE STRAIN W/POSS INTERNAL DERANGEMENT, CLOSED HEAD INJURY.

82 YOF WITH NO INJ FROM FALL IN TUB

85 YOM WITH NO IN, FELL IN BATHTUB, ADMITTED FOR OTHER REASONS

52 YOM W/ALS FELL AND BECAME STUCK BETWEEN TOILET AND TUB. DX: RHABDOMYOLYSIS STATUS POST FALL, NASAL FX.

95 YOF FELL IN SHOWER SUSTAINING CHEST CONTUSION

71 YOF SLIPPED AND FELL IN SHOWER. DX: SYNCOPE, LARGE HEAD LAC, COAGULOPATHY, HYPOKALEMIA, LONT QT, ALCO

79 YOF FELL IN SHOWER SUSTAINING A FRACTURED KNEE

87 YOF WITH RIB FRACTURE FROM FALL IN TUB

79 YOM WITH LOWER BACK STRAIN FROM FALL IN SHOWER

81 YOF TURNED IN SHOWER AND FELL SUSTAINING A FRACTURED HIP

97 YOF FELL IN THE SHOWER AT NURSING HOME. DX: TRAUMATIC SDH, AGGITATION.

70 YOF FELL IN SHOWER AT HOME AND WAS UNABLE TO GET UP, SUSTAINED CHI, BACK CONTUSIONS

88 YOF FELL AGAINST BATHTUB AND WALL AT ASSISTED LIVING. DX: BACK/SHOUL PX, SYNCOPE, STAGE I THORACIC DECUBITUS ULCER, MULT OLD THORACIC FX'S.

88 YOF SLIPPED ON WET FLOOR GETTING OUT OF SHOWER AT NURSING HOME. DX: BACK CONT, PNEUMONIA, HYPOXEMIA, PLEURAL EFFUSION.

41YOF WITH NO INJURIES FROM FALL IN SHOWER, WAS ADMITTED

83 YOM FELL IN THE SHOWER. DX: TRAUMATIC ICH, FACIAL LAC, CONCUSSION W/O LOC, RENAL FAILURE.

94 YOM FELL GETTING OUT OF THE SHOWER AND HIT HEAD SUSTAINING A LACERATION

79 YOM FELL ON SIDE OF BATHTUB. DX: SYNCOPE, CHEST WALL CONT.

55 YOM SLIPPED AND FELL IN BATHTUB. DX: R HEMOTHORAX/PNEUMOTHORAX, MULT R RIB FX'S.

86 YOF FELL BACKWARDS INTO BATHTUB & HIT HEAD AT HOME DX: LACERATION TO SCALP/ ACUTE DEHYDRATED

95 YOF TRIPPED OVER THROW RUG WHILE GETTING INTO SHOWER AT HOME DX; AVULSION TO FACE/ MALIGNANT HYPERTENSION

53 YOF SLIPPED IN SHOWER AND FELL HITTING HIP ON TOILET AT HOME DX: STRA

Bibliography:

Bibliography for Jake Pauls Proposal for IBC Section 1003 on Grab Bars for Bathtubs, Bathtub-Shower Combinations and Showers

Approximately 50 internationally-produced scientific and technical references, on bathing/showering safety, were compiled by the proponent, in 2016, for an American Public Health Association (APHA) draft policy highlighting, especially two Canadian research studies that also are addressed in video presentations by Principal Investigators (Dr. Nancy Edwards, Dr. Alison Novak) for the research and posted, for free streaming viewing at, <https://vimeo.com/164239941> Accessed January 8, 2018. Additional videos covering technical aspects of bathing and showering safety (including cost impact and benefit issues*) are found at the following links (all of which are available, with descriptions, at www.bldguse.com, the proponent's Professional Practice Website, Accessed January 8, 2018.).

- <https://vimeo.com/237294479>
- <https://vimeo.com/239276202> *
- <https://vimeo.com/197742277>
- <https://vimeo.com/193507768>
- <https://vimeo.com/173883358>
- <https://vimeo.com/175101448> *
- <https://vimeo.com/117572176>

Bibliography Entries. The draft policy statement, for APHA consideration in 2016, was titled, “Improving Fall Safety and Related Usability of Bathrooms within Buildings through Safety Standards, Building Codes, Housing Codes and Other Mechanisms.” (The numbers shown for this bibliography—in connection with the ICC code change proposal—are those used in the 2016 draft policy.)

1. Edwards N, Birkett N, Nair R, et al. Access to bathtub grab bars: evidence of a policy gap. *Can J Aging* 2006;25:295-304.
2. Chauvin J, Pauls J, Strobl L. Building Codes: an often overlooked determinant of health. *J. Public Health Policy* 2016;37(2):136-48.
3. Centers for Disease Control and Prevention. Nonfatal Bathroom Injuries Among Persons Aged ≥15 Years United States, 2008. *MMWR* 2011;60:729-33.
4. Lockett D, Aminzadeh F, Edwards N. Development and evaluation of an instrument to measure seniors' attitudes toward the use of bathroom grab bars. *Public Health Nurs* 2002;19:390-397.
5. Aminzadeh F, Edwards N, Lockett D, Nair RC. Utilization of bathroom safety devices, patterns of bathing and toileting, and bathroom falls in a sample of community living older adults. *Technology and Disability* 2000;13:95-103.
6. Kira A. *The Bathroom. New and Expanded Edition*, The Viking Press, New York, 1976.
7. Lawrence B, Spicer R, Miller T. A fresh look at the costs of non-fatal consumer product injuries. *Injury Prevention* 2015;21:23-9.
8. US CPSC NEISS. National Electronic Injury Surveillance System (NEISS). US Consumer Product Safety Commission. Available at: www.cpsc.gov/en/Research--Statistics/NEISS-Injury-Data/ Accessed August 8, 2016.
9. Cote R. Grab Hold: Considering grab bars to prevent falls in baths and showers. *NFPA Journal*, November-December 2015. Available at: <http://www.nfpa.org/newsandpublications/nfpa-journal/2015/november-december-2015/in-compliance/nfpa-1>. Accessed August 8, 2016.
10. Mao SJ, McKenzie LB, Xiang H, Smith, GA. Injuries associated with bathtubs and showers among children in the United States *Pediatrics* August 2009;124(2):541-7.
11. Stone RF, Blackwell D, Burton DJ. A systematic program to reduce the incidence and severity of bathtub and shower area injuries. US Consumer Product Safety Commission Contract No.: CPSC-P-74-334, Report. Cambridge, MA: Abt Associates, 1975. Available at: www.cpsc.gov/pagefiles/93711/os1b.pdf Accessed August 9, 2016.
12. Lawrence B, Miller T, Jensen A, et al. Estimating the costs of non-fatal consumer product injuries in the United States. *Inj Control Saf Promot* 2000;7:97-113.
13. Queensland Injury Surveillance Unit. Bathroom injuries in Queensland. *Injury Bulletin* 2006;91. Available at: www.qisu.org.au/ModCoreFilesUploaded/Bulletin_9198.pdf. Accessed August 10, 2016.
14. Professional Education, American Geriatrics Society. Summary of the Updated American Geriatrics Society/British Geriatrics Society Clinical Practice Guideline for Prevention of Falls in Older Persons *J Am Geriatr Soc* 2011 Jan;59(1):148-57. Available at: <http://www.ncbi.nlm.nih.gov/pubmed/21226685> accessed August 10, 2016.
15. Tinetti ME, Speechley M, Ginter SF. Risk factors for falls among elderly persons living in the community. *New England Journal of Medicine* 1988;319(26): 1701-07.
16. Shields W, McDonald E, Frattaroli S, et al. Structural housing elements associated with home injuries in children *Inj Prev* 2016;22:105-109.
17. Gill TM, Williams CS, Robinson JT, Tinetti ME. A population-based study of environmental hazards in the homes of older persons. *Am J Public Health* 1998;89:553-6.
18. Gill TM, Williams CS, Tinetti ME. Environmental hazards and the risk of nonsyncopal falls in the homes of community-living older persons. *Med Care* 2000;38:1174-83.
19. Marshall SW, Runyan CW, Yang J, et al. Prevalence of selected risk and protective factors for falls in the home. *Am J Prev Med* 2005;28(1):95-101.
20. Runyan CW, Perkis D, Black C, et al. Unintentional injuries in the home in the United States. Part II: morbidity. *Am J Prev Med* 2005;28:80 -7.

21. Sattin RW, Rodriguez JG, DeVito CA, Wingo PA, Study to Assess Falls Among the Elderly (SAFE) Working Group. Home environmental hazards and the risk of fall injury events among community-dwelling older persons. *J Am Geriatr Soc* 1998;46:669–76.
22. Lawrence, BA. Revised Incidence Estimates for Nonfatal, Non-Hospitalized Consumer Product Injuries Treated Outside Emergency Departments. Draft Final Report to the U.S. Consumer Product Safety Commission, Task Order 2, Contract CPSC-D-09-0003, April 30, 2013 Available at: <https://www.cpsc.gov/PageFiles/169938/DecisionTree.pdf> Accessed August 14, 2016.
23. Sveistrup H. Patterns of use of different toilet grab bar configurations by community-living older adults Research Highlight (Canada Mortgage and Housing Corporation) 2013.
24. Sveistrup H, Lockett D, Edwards N, Aminzadeh F. Evaluation of bath grab bar placement for older adults. *Technology and Disability* 2006;13(39):1-11.
25. Ellis N. Introduction to Fall Protection. American Society of Safety Engineers, Des Plaines, IL, 2011, 122-3.
26. Novak A, King E. Final Report for National Research Council, Joint Task Group on Grab Bars: Biomechanical investigation of grab bar use and balance control during bathing transfers. Toronto Rehab Institute – University Health Network, Toronto, Canada, 2016
28. Edwards N, Lockett D, Aminzadeh F, Nair RC. Predictors of bath grab-bar use among community living older adults. *Can J Aging* 2002;22:217–27.
29. Sveistrup H, Lockett D, Edwards N, Aminzadeh F. Evaluation of bath grab bar placement for older adults. *Technology and Disability* 2006;13; 1-11
30. Guitard P, Sveistrup H, Edwards N, Lockett D. Use of different bath grab bar configurations following a balance perturbation. *Assistive Technology* 2011;23:205-15
31. Siegmund GP, Flynn J, Mang DW, Chimich DD, Gardiner JC. Utilized friction when entering and exiting a dry and wet bathtub. *Gait & Posture* 2010; 31(4):473-8.
32. Sparrow WA, Shinkfield A, Chow S, Begg RK. Characteristics of gait in stepping over obstacles. *Hum Movement Sci* 1996;15:605–22.
35. U.S. Department of Justice. Americans with Disabilities Act Standards for Accessible Design. 2010 § 607-809. Available at: <http://www.ada.gov/regs2010/2010ADASTandards/2010ADASTandards.htm>. Accessed 08/10/16.
36. U.S. Department of Housing and Urban Development. Fair Housing Design Manual: A manual to assist designers and builders in meeting the accessibility requirements of the Fair Housing Act. Available at: www.huduser.gov/portal/publications/destech/fairhousing.html Accessed 08/10/16.
37. Pacific Institute for Research and Evaluation. Injury Prevention: What works? A Summary of cost-outcome analysis for injury prevention programs. Report prepared for Children’s Safety Network. 2014.
38. Gillespie LD, Gillespie WJ, Robertson MC, et al. Interventions for preventing falls in elderly people. *Cochrane Database Syst Rev* 2003;4:CD000 Available at: www.cochranelibrary.com/cochrane-database-of-systematic-reviews/index.html accessed August 10, 2016.
39. Turner S, Arthur G, Lyons RA, et al. Modification of the home environment for the reduction of injuries. *Cochrane Database of Systematic Reviews* 2011, Issue 2. Art. No.: CD003600. DOI: 10.1002/14651858.CD003600.pub Available at: www.cochranelibrary.com/cochrane-database-of-systematic-reviews/index.html accessed August 10, 2016.
40. Kendrick D, Young B, Mason-Jones AJ, et al. Home safety education and provision of safety equipment for injury prevention. *Cochrane Database of Systematic Reviews* 2012, Issue 9. Art. No.: CD005014. DOI: 10.1002/14651858.CD005014.pub3. Available at: www.cochranelibrary.com/cochrane-database-of-systematic-reviews/index.html accessed August 10, 2016.
41. Keall MD, Howden-Chapman P, Baker MG, et al. Formulating a programme of repairs to structural home injury hazards in New Zealand. *Accid Anal Prev* 2013;57:124–
42. Keall MD, Piersie N, Howden-Chapman P, et al. Home modifications to reduce injuries from falls in the Home Injury Prevention Intervention (HIPI) study: a cluster-randomised controlled trial. *Lancet* 2015;385:231–8.
43. Kaniewaki M, Stevens JA, Parker EM, Lee R. An introduction to the Centers for Disease Control and Prevention’s efforts to prevent older adult falls. *Front Public Health* 2014;2:119.
44. Stevens JA, Phelan EA. Development of STEADI: A fall prevention resource for health care providers. *Health Promot Pract.* 2013;14(5): 706–714. (See Table 2 where the brochure, Check for Safety, is listed under Patient educational materials.)
45. CDC National Center for Injury Prevention and Control. Check for Safety: A home fall prevention checklist for older adults. US CDC 1999.
46. CDC National Center for Injury Prevention and Control. Check for Safety: A home fall prevention checklist for older adults. US CDC 2016. Available at: www.cdc.gov/steady/patient.html Accessed August 9, 2016.
47. Lunsford B, Wilson LD. Assessing your patients’ risk for falling. *American Nursing Today* 2015;10(7). Available at: <https://americannursetoday.com/assessing-patients-risk-falling/> Accessed January 8, 2018.

Other items for the Proposal Bibliography (from post-2016 sources) and one earlier paper specific to (transfer) pole-type grab bars which are included in the IBC proposal.

- Novak A, King E. Final Report for National Research Council, Joint Task Group on Grab Bars: Biomechanical investigation of grab bar use and balance control during bathing transfers. Toronto Rehabilitation Institute-University Health Network, 2017.
- King EC, Novak AC. Centennial Topics—Effect of bathroom aids and age on balance control during bathing transfers. *American Journal of Occupational Therapy*, 71, 1-9, 2017. Available at <https://doi.org/10.5014/ajot.2017.027136>. Accessed January 8, 2018.
- Vena D, Novak AC, King EC, Dutta T, & Fernie GR. The Evaluation of Vertical Pole Configuration and Location on Assisting the Sit-to-Stand Movement in Older Adults with Mobility Limitations. *Assistive Technology* 27, 4, 2015, Available at <http://www.tandfonline.com/doi/full/10.1080/10400435.2015.1030514>. Accessed January 8, 2018. (In referring to sit-to-stand transfers, as from a toilet, this article uses the term, “transfer poles,” to describe the configuration and location of “poles” referred to in the code change proposal.)

Cost Impact

The code change proposal will increase the cost of construction .

The code change proposal will increase the cost of construction, but that increased cost pales in comparison to the benefits of enhanced usability and reduction of fall injuries.

The additional material in the form of conventional grab bars or poles plus their fixings is about 50 dollars per grab bar or pole (using retail prices for the components confirmed as recently as 2017) and with a conventional three-fixture bathroom with a bathtub there would be a need for two such grab bars or poles or one of each. Labor to install these would be about one hour for each. Thus an overall, installed cost is on the order of \$200 per bathroom. The service life would be on the order of two or more decades.

Against this added cost of an installed single grab bar or two per bathroom there are the ongoing benefits of enhanced normal (non-injury) uses which, for a typical US household for a 20-year period, for example, number about 7,000 per person or on the order of 20,000 per household. Those enhanced uses, with grab bars, have an economic value that is larger than the benefit of averted injuries from falls.

Currently without grab bars, our bathtubs and showers are the site of injuries serious enough to require professional medical attention at a rate, annually (using 2010 data) of about 1 million per 110 billion uses or about one in 110,000 uses. Every one of those non-injury uses has a value. By comparison, for stairs this ratio is about one professionally treated fall injury for every million flight uses in home settings and one such injury for every ten million flight uses in public settings where, under the IBC and more-detailed inspection procedures, stairs are nearly one order of magnitude safer than those nominally constructed under the IRC. See the video presentation by Jake Pauls to the April 2017 meeting, “The Impact of Building Codes and Standards in Public Health and Safety,” held in Melbourne, Australia, in connection with the 15th World Congress on Public Health. The streaming video containing this presentation, which includes the “Injury Pyramids” used for the above stair safety calculation, is available freely at <https://vimeo.com/239276202> (as listed in the first part of the Bibliography accompanying this proposal) accessed Jan 8, 2018.

The injuries-averted benefit, over twenty years, has a value, in 2010 dollars, about 6.5 times greater than the installation cost, based on the very reasonable assumption that half the falls are averted with the specified grab bars or poles. For the vertical poles that also enhance and make safer the use of toilets that, being adjacent to a bathtub, can serve stand-to-sit and sit-to-stand transfers for toileting, this benefit increases by about 35 percent to nearly 9 times greater than the installation cost. These projections are based on the injury economic data provided by the 2015 paper in the respected journal, *Injury Prevention*, by Lawrence, Spicer and Miller (see Bibliography for details).

The bottom line is that the benefits of both enhanced normal uses, in the tens of thousands per household over a 20-year period, combined with the benefit of averted injuries, is on the order of at least 20 or more times the cost of providing the grab bars, especially if they take the form of vertical poles serving bathtub-shower combination users as well as toilet users in a three-piece bathroom provision that is very common in homes and hotels, for example. For hotels, while the lavatory sink(s) may be in a separate space, the toilet and bathtub-shower combination are usually close together so that a single pole can serve transfers for both. Thus the cost impact of grab bar or pole installations is very small in relation to the benefits and that cost of installation is very small in relation to the overall price of a dwelling unit or hotel guest room for example.

Finally, the choice of residential settings for the foregoing benefit-cost analyses, reflects the greater attention such occupancies often receive in code change deliberations. Healthcare occupancies could also have been chosen for analyses as estimates of fall-related injuries to patients are that about “one-third of reportable falls with injuries in hospitalized older adults are linked to bathroom use” (quoted from reference identified as number 47 in the Bibliography for this proposal). Notably, in the recent NFPA deliberations on installation of grab bars, only healthcare occupancies were not included due to healthcare industry and healthcare fire protection engineering consultants’ opposition based on the claim that patients in healthcare were not permitted to use bathrooms without supervision.

The personal, post-fall (with closed-head injuries) experience recently by the proponent of this code change in three hospitals in Sweden, Australia and the USA, seriously questions this industry claim as well as the implicit assumption that bathrooms in healthcare provide reasonable safety from falls suffered in the course of toileting as well as bathing. Too often, the wheeled stand (with the vertical pole holding fluid being administered intravenously) is the most reliable “point of control” such patients have between their beds and toileting/bathing facilities either in the patient bedrooms or “down the hall.”

Internal ID: 1066

E2-18

IBC: 1003.4.1 (New), Chapter 35, (IFC[BE] 1003.4.1, Chapter 80)

Proponent: Bill Griese, Tile Council of North America, representing Tile Council of North America (bgriese@tileusa.com); Todd Scharich, American Society of Concrete Contractors, representing American Society of Concrete Contractors (TScharich@ASCCONLINE.ORG); Charles Muehlbauer, Natural Stone Institute, representing Natural Stone Institute (Charles@naturalstoneinstitute.org); Katelyn Simpson, representing TCNA Laboratory (ksimpson@tileusa.com); Jennifer Ann Faller, representing Concrete Polishing Council (CPC) (concreteinsite@gmail.com); Mark Fowler, representing National Terrazzo & Mosaic Association (mark@ntma.com)

2018 International Building Code

1003.4 Slip-resistant surface. Circulation paths of the *means of egress* shall have a slip-resistant surface and be securely attached.

Add new text as follows:

1003.4.1 Hard surface flooring. Hard surface flooring shall be slip-resistant in accordance with ANSI A326.3.

Add new standard(s) follows:

ANSI

American National Standards
Institute
25 West 43rd Street, Fourth Floor
New York NY 10036
US

A326.3-18:

Test Method for Measuring Dynamic Coefficient of Friction for Hard Surface Floor Materials

Reason:

Currently, Section 1003.4 requires that circulation path surfaces of the means of egress be “slip-resistant” with no method of measurement, quantitative threshold, or general principles to help the specifier, end-user and code official. Given the Code’s lack of criteria for “slip-resistant,” materials are sometimes being inappropriately specified, and accidents occur in areas of the means of egress. This can be especially dangerous for emergency responders who are entering a building for the first time, potentially under conditions with water and limited visibility (smoke).

The purpose of this revision is to provide slip resistance criteria for hard surface flooring used in interior circulation paths. The proposed reference standard, ANSI A326.3, sets forth a quantitative minimum threshold, means of measurement, and general principles regarding slip resistance for hard surface flooring and is widely specified for ceramic tile, polished concrete, terrazzo, and natural stone. This would provide clarity, safety, and transparency with no increased cost of construction.

This proposal is being submitted by Tile Council of North America (TCNA), Natural Stone Institute, American Society of Concrete Contractors (ASCC), Concrete Polishing Council (CPC), and National Terrazzo and Mosaic Association (NTMA), with the support of many other organizations.

Previously, slip resistance for ceramic tile was standardized solely by ANSI A137.1 American National Standard Specifications for Ceramic Tile. In 2012, a proposal (S222-12) was approved which removed ANSI A137.1 from Section 2103 of the Code (previously, Section 2103.6) in an effort to consolidate masonry-based specification references. An unintended consequence of this change was that the Code was subsequently left with no slip resistance criteria for ceramic tile, much less stone, terrazzo, or concrete.

In 2015, a proposal (E3-15) was made to reintroduce the slip resistance provisions of ANSI A137.1 into the Code. Given that these provisions were being widely adopted and specified for flooring types beyond just ceramic tile, the scope of the proposal included other hard surface flooring types with the support of each respective industry. The proposal was met with positive feedback from the Means of Egress Committee, but was ultimately disapproved since the proposed reference standard was limited to ceramic tile. At the time, the Committee encouraged the proponents to collaborate on a stand-alone slip resistance specification which covered all hard surface flooring types and return in 2018 with a proposal.

Today, this work has been done for all hard surface flooring and is standardized in ANSI A326.3, including in the standard test sample size and testing in as-is conditions or under cleaned conditions. This standard is widely understood for hard surface flooring and specified throughout the architectural community with hard surface

manufacturers/suppliers/installers regularly providing the information needed by code officials as part of standard product submittals and information. Revising Section 1003.4 to reference ANSI A326.3 for hard surface flooring would clear-up ambiguity around the requirement for “slip-resistant” circulation path surfaces, facilitate increased safety and ease-of-specification, and codify the slip resistance standard which is most predominately used today for hard surface flooring.

ANSI ASC A108, the committee which developed ANSI A326.3, represents a broad range of stakeholders, including the Construction Specifications Institute (CSI), Natural Stone Institute, National Association of Homebuilders (NAHB), Underwriter Laboratories (UL), National Tile Contractors Association (NTCA), Tile Council of North America (TCNA), and 58 additional stakeholders (for a total of 64).

A copy of ANSI A326.3 has been attached to this proposal and is also easily accessible for free online via www.TCNAtile.com.

Bibliography:

[TCNA Tile Initiative] [Research Supporting an American National Standard for Slip Resistance] [Eric Astrachan] [2016] [Pages 2 - 9] [http://www.tcnatile.com/images/pdfs/Rsch_suptng_ANSI_std_slip_resist_TCNA_TI_Mar-2016.pdf]

[Slip and Fall Study Report: Enhancing Floor Safety Through Slip Resistance Testing, Maintenance Protocols and Risk Awareness] [CNA Financial Corporation] [2017] [http://www.tcnatile.com/images/pdfs/CNA_Risk_Control_Slip_and_Fall_Report_Final.pdf]

Cost Impact

The code change proposal will not increase or decrease the cost of construction .

Hard surface flooring that meets or exceeds the criteria of the ANSI A326.3 standard is not different in price from hard surface flooring that is below the threshold criteria.

Analysis: A review of the standard proposed for inclusion in the code, ANSI A326.3-18, with regard to the ICC criteria for referenced standards (Section 3.6 of CP#28) will be posted on the ICC website on or before April 2, 2018.

Internal ID: 1195

E3-18

IBC: 1003.4.1 (New), Chapter 35 (IFC[BE] 1003.4.1 (New), Chapter 80)

Proponent: Bill Griese, Tile Council of North America, representing Tile Council of North America
(bgriese@tileusa.com)

2018 International Building Code

1003.4 Slip-resistant surface. Circulation paths of the *means of egress* shall have a slip-resistant surface and be securely attached.

Add new text as follows:

1003.4.1 Resilient flooring. Resilient flooring shall be slip-resistant in accordance with UL 410.

Add new standard(s) follows:

UL

UL LLC
333 Pfingsten Road
Northbrook IL 60062-2096
US

410-2006:

Standard for Slip Resistance of Floor Surface Materials

Reason:

This proposal is being submitted by Tile Council of North America (TCNA) with the support of the Resilient Floor Covering Institute (RFCI). It clarifies that UL 410 is the intended slip resistance standard for resilient flooring. This is a clear distinction from ANSI A326.3 which is used for hard surface flooring as proposed in a separate Code Change Proposal.

Currently, Section 1003.4 requires that circulation path surfaces of the means of egress be “slip-resistant” with no method of measurement, quantitative threshold, or general principles to help the specifier, end-user and code official. Given the Code’s lack of criteria for “slip-resistant,” materials are sometimes being inappropriately specified, and accidents occur in areas of the means of egress.

The purpose of this revision is to provide slip resistance criteria for resilient flooring used in interior circulation paths. The proposed reference standard, UL 410, sets forth a quantitative minimum threshold, means of measurement, and general principles regarding slip resistance for resilient flooring and is widely used throughout the resilient flooring industry. This revision would provide clarity, safety, and transparency with no increased cost of construction.

Cost Impact

The code change proposal will not increase or decrease the cost of construction .

Resilient flooring that meets or exceeds the criteria of the UL 410 standard is not different in price from resilient flooring that is below the threshold criteria.

Analysis: A review of the standard proposed for inclusion in the code, UL 410-2006, with regard to the ICC criteria for referenced standards (Section 3.6 of CP#28) will be posted on the ICC website on or before April 2, 2018.

Internal ID: 1196

E4-18

IBC: 1003.5, 1010.1.5 (IFC[BE] 1003.5, 1010.1.5)

Proponent: Mark Swanson, Swanson Assoc. Engineering, representing Swanson & Assoc. Engineering (ms@swanson-engr.com)

2018 International Building Code

Revise as follows:

1003.5 Elevation change. Where changes in elevation of less than 12 inches (305 mm) exist in the *means of egress*, sloped surfaces shall be used. Where the slope is greater than one unit vertical in 20 units horizontal (5-percent slope), *ramps* complying with Section 1012 shall be used. Where the difference in elevation is 6 inches (152 mm) or less, the *ramp* shall be equipped with either *handrails* or floor finish materials that contrast with adjacent floor finish materials.

Exceptions:

- ~~1. A single step with a maximum riser height of 7 inches (178 mm) is permitted for buildings with occupancies in Groups F, H, R-2, R-3, S and U at exterior doors not required to be accessible by Chapter 11. At exterior doors in accordance with Section 1010.1.5.~~
- A *stair* with a single riser or with two risers and a tread is permitted at locations not required to be accessible by Chapter 11 where the risers and treads comply with Section 1011.5, the minimum depth of the tread is 13 inches (330 mm) and not less than one *handrail* complying with Section 1014 is provided within 30 inches (762 mm) of the centerline of the normal path of egress travel on the *stair*.

Throughout a story in a Group I-2 occupancy, any change in elevation in portions of the *means of egress* that serve nonambulatory persons shall be by means of a *ramp* or sloped walkway.

1010.1.5 Floor elevation. There shall be a floor or landing on each side of a door. Such floor or landing shall be at the same elevation on each side of the door. Landings shall be level except for exterior landings, which are permitted to have a slope not to exceed 0.25 unit vertical in 12 units horizontal (2-percent slope).

Exceptions:

- ~~Doors At doors serving individual *dwelling units* or *sleeping units* in Groups R-2 and R-3 where the following apply:~~
 - ~~1.1. A door is permitted to open at the top step of an interior *flight* of stairs, provided that the door does not swing over the top step.~~
 - ~~1.2. Screen doors and storm doors are permitted to swing over *stairs* or landings.~~
- ~~Exterior doors as provided for in Section 1003.5, Exception 1, and Section 1022.2, which are not on an accessible route.~~
- At exterior doors serving Groups F, H, R-2 and S and where such doors are not part of an accessible route, the landing at an exterior door shall not be more than 7 inches (178 mm) below the landing on the egress side of the door, provided the door, other than an exterior storm or screen door, does not swing over the landing.
- ~~In Group R-3 occupancies At exterior doors serving Group U and individual *dwelling units* and *sleeping units* in Group R-2 and R-3, and where such units are not required to be *Accessible units*, *Type A units* or *Type B units*, the landing at an exterior doorway shall be not more than 7³/₄ inches (197 mm) below the landing on the top egress side of the threshold, provided the door, other than an exterior door. Such doors, including storm or screen door, does not shall be permitted to swing over the either landing.~~
- Variations in elevation due to differences in finish materials, but not more than 1/2 inch (12.7 mm).
- Exterior decks, patios or balconies that are part of Type B *dwelling units* or *sleeping units*, that have impervious surfaces and that are not more than 4 inches (102 mm) below the finished floor level of the adjacent interior space of the *dwelling unit* or *sleeping unit*.
- Doors serving equipment spaces not required to be accessible in accordance with Section 1103.2.9 and serving an *occupant load* of five or less shall be permitted to have a landing on one side to be not more than 7 inches (178 mm) above or below the landing on the egress side of the door.

Reason:

Exterior doors typically occur with some change of elevation at the door. The amount of the elevation change is sometimes dependent on the occupancy. This proposal coordinates and clarifies code language for this typical condition. The intent and limitations of the code with respect to this subject is currently spread over several sections. This proposal clarifies the code intent as stated in the commentary.

Section 1003.5

Section 1003.5 is a general condition for elevation changes. Exception 1 currently addresses a special condition—elevation change at doors. The proposal moves this section to the doors section 1010.1.5. This change is editorial.

Section 1010.1.5

Exception 1: The proposed modification to 1010.1.5 removes and relocates exception 1.1 and 1.2 into exception 1 and exception 3. This simplification is primarily editorial.

Exception 2: The proposed modification contains the code language previously stated in Section 1003.5. The proposal now prohibits the outward swing of a door over a step in these occupancies. Steps at doors can create a trip hazard for the occupants.

Exception 3: The proposed modification allows individual dwelling and sleeping units and U occupancies to be governed by the same change in elevation as Group R-3. This is consistent with stairway rise/run provisions where Group R-3 and individual units in R-2 are governed by the same rules.

The additional language regarding the direction of swing is necessary because such statement is not made in any other code section. The building code commentary clarifies the direction of swing and the reasoning behind it, as follows--"Exception 1 allows up to a 7-inch step at exterior doors to avoid blocking the outward swing of the door by a build-up of snow or ice in locations that are not used by the public on a regular basis" the commentary goes on to say "the door may swing in either direction for this exception and may actually be required to swing out." Given the clear intent in the commentary, the proposed change to the code will clear up any doubt about the swing of the door.

The current code language allows doors in group F, R-3, R-2, S, and U occupancies to swing outward over a step to avoid the blocking of the outward swing from snow or ice. The revised proposal will limit outward swinging doors at a step to the Groups in exception 3, where transient type occupants will be familiar with the doorway conditions where the occupant load is low, and the trip hazard is unlikely.

Bibliography:

2015 IBC Vol. 1, Code and Commentary, ICC

2018 IBC Vol. 1, Code and Commentary, ICC

email "2012 IBC Section 1003.5, 1008.1.5, and IRC Section 311.3.1" ICC code opinion, Aug 13, 2015,

Cost Impact

The code change proposal will not increase or decrease the cost of construction .

The change is primarily editorial. Certain provisions have been relocated, and interpretive language from the code commentary has been included in the text of the code .

Internal ID: 1784

E5-18

IBC: 1004.4, (IFC[BE] 1004.4)

Proponent: Jeffrey Tubbs, Arup, representing Arup (jeff.tubbs@arup.com)

2018 International Building Code

Revise as follows:

~~1004.4~~**1003.8 Multiple occupancies.** Where a building contains two or more occupancies, the *means of egress* requirements shall apply to each portion of the building based on the occupancy of that space. Where two or more occupancies utilize portions of the same *means of egress* system, those egress components shall meet the more stringent requirements of all occupancies that are served. Where buildings contain accessory occupancies in accordance with Section 508.2, the means of egress requirements shall separately apply to each portion of the building and shall be based on the occupancy of each space.

Reason:

The original code section provides requirements for egress components. However, the requirement was located within the occupant load section. Given the location, it was unclear how this requirement applied to egress components. The code change moves the requirement to the general section to clarify that application. The code change further provides a reasonable allowance for small Accessory occupancies where the risk lower due to low occupant load, or the risk is mitigated through fire separation.

Cost Impact

The code change proposal will decrease the cost of construction .

The code change includes an allowance for accessory occupancies. Therefore, in theory the code change should reduce the cost of construction for some buildings.

Internal ID: 1289

E6-18

IBC: TABLE 1004.5, (IFC[BE] TABLE 1004.5)

Proponent: Micah Chappell, representing City of Seattle (micah.chappell@seattle.gov)

2018 International Building Code

Revise as follows:

**TABLE 1004.5
MAXIMUM FLOOR AREA ALLOWANCES PER OCCUPANT**

FUNCTION OF SPACE	OCCUPANT LOAD FACTOR ^a
Accessory storage areas, mechanical equipment room	300 gross
Agricultural building	300 gross
Aircraft hangars	500 gross
Airport terminal	20 gross
Baggage claim	300 gross
Baggage handling	100 gross
Concourse Waiting areas	15 gross
Assembly	
Gaming floors (keno, slots, etc.)	11 gross
Exhibit gallery and museum	30 net
<u>Billiard table/game table area</u>	<u>50 gross</u>
Assembly with fixed seats	See Section 1004.6
Assembly without fixed seats	7 net
Concentrated	5 net
(chairs only—not fixed)	15 net
Standing space	
Unconcentrated (tables and chairs)	
Bowling centers, allow 5 persons for each lane including 15 feet of runway, and for additional areas	7 net
Business areas	150 gross
Concentrated business use areas	See Section 1004.8
Courtrooms—other than fixed seating areas	40 net
Day care	35 net
Dormitories	50 gross
Educational	20 net
Classroom area	50 net
Shops and other vocational room areas	
Exercise rooms	50 gross
Group H-5 fabrication and manufacturing areas	200 gross
Industrial areas	100 gross
Institutional areas	240 gross
Inpatient treatment areas	100 gross
Outpatient areas	120 gross
Sleeping areas	
Kitchens, commercial	200 gross
Library	50 net
Reading rooms	100 gross
Stack area	
Locker rooms	50 gross
Mall buildings—covered and open	See Section 402.8.2
Mercantile	60 gross
Storage, stock, shipping areas	300 gross
Parking garages	200 gross
Residential	200 gross
Skating rinks, swimming pools	50 gross
Rink and pool	15 gross
Decks	
Stages and platforms	15 net
Warehouses	500 gross

For SI: 1 foot = 304.8 mm, 1 square foot = 0.0929 m².

- a. Floor area in square feet per occupant.

Reason:

Many occupancies contain uses not classified in Table 1004.5. This proposed change clarifies the design occupant load for an occupancy use commonly seen in proposed projects. Billiards and gaming table rooms, since the tables take up

a large portion of the floor area, it makes sense to use an occupant load factor of 50 gross, similar to exercise rooms instead of the occupant load of 11 gross for gaming floors. Billiards tables, or similar, are used for the game of pool as indicated by the definition.

Definition of Billiard Table:

a table having a slate bed covered with billiard cloth and surrounded by cushioned rails on which billiards is played; also : any similar table provided with six pockets for the playing of pool or English billiards.

Cost Impact

The code change proposal will not increase or decrease the cost of construction .

The net effect of this change will be to reduce the design occupant load, which will lead to a need for fewer required exits and plumbing facilities. See example below:

3000-SF-Room-(example)¶ Assuming A-2 Occupancy¶	Occ.-Load-1:11-GSF¶	Occ.-Load-1:50-GSF- (proposed)¶
Occupants¶	272¶	60¶
Exits-required¶	2R¶	2R¶
WC's-required¶	4M+-4F¶	2M+-2F¶
Lav's-required¶	2M+-2F¶	1M+-1F¶

Internal ID: 1681

E7-18**IBC: TABLE 1004.5, (IFC[BE] TABLE 1004.5)****Proponent:** Dave Frable, representing U.S. General Services Administration (dave.frable@gsa.gov)**2018 International Building Code****TABLE 1004.5
MAXIMUM FLOOR AREA ALLOWANCES PER OCCUPANT**

FUNCTION OF SPACE	OCCUPANT LOAD FACTOR^a
Accessory storage areas, mechanical equipment room	300 gross
Agricultural building	300 gross
Aircraft hangars	500 gross
Airport terminal	20 gross
Baggage claim	300 gross
Baggage handling	100 gross
Concourse Waiting areas	15 gross
Assembly	11 gross
Gaming floors (keno, slots, etc.)	30 net
Exhibit gallery and museum	
Assembly with fixed seats	See Section 1004.6
Assembly without fixed seats	7 net
Concentrated	5 net
(chairs only—not fixed)	15 net
Standing space	
Unconcentrated (tables and chairs)	
Bowling centers, allow 5 persons for each lane including 15 feet of runway, and for additional areas	7 net
Business areas	150 gross
Concentrated business use areas	See Section 1004.8
<u>Collaboration rooms/spaces ≤ 450 ft² in area</u>	<u>30 gross</u>
<u>Collaboration rooms/spaces > 450 ft² in area</u>	<u>15 gross</u>
<u>Conference rooms</u>	<u>15 net</u>
Courtrooms—other than fixed seating areas	40 net
Day care	35 net
Dormitories	50 gross
Educational	20 net
Classroom area	50 net
Shops and other vocational room areas	
Exercise rooms	50 gross
Group H-5 fabrication and manufacturing areas	200 gross
Industrial areas	100 gross
Institutional areas	240 gross
Inpatient treatment areas	100 gross
Outpatient areas	120 gross
Sleeping areas	
Kitchens, commercial	200 gross
Library	50 net
Reading rooms	100 gross
Stack area	
Locker rooms	50 gross
Mall buildings—covered and open	See Section 402.8.2
Mercantile	60 gross
Storage, stock, shipping areas	300 gross
Parking garages	200 gross
Residential	200 gross

Skating rinks, swimming pools Rink and pool Decks	50 gross 15 gross
Stages and platforms	15 net
Warehouses	500 gross

For SI: 1 foot = 304.8 mm, 1 square foot = 0.0929 m².

- a. Floor area in square feet per occupant.

Reason:

This code change proposes to add a new addition to Table 1004.5 for business areas to address collaboration rooms/spaces which are now commonly being located in open office space environments in office buildings. Businesses currently operating in predominantly open office environments tend to need more collaboration rooms/spaces for private meetings between staff, both for small personnel meetings and team meetings, etc. Based on our experience, many questions have arisen concerning these types of designs in open office space environments in our Federal buildings regarding how the design team should calculate the occupant loads for these types of proposed space uses. Concerns have also been raised regarding the appropriateness of using the current occupant load factors in the IBC, for these types of rooms/spaces. In addition, there have been different interpretations among A/E firms, fire protection engineer consultants, and AHJs regarding how these specific rooms and spaces identified on drawings are to be utilized by building occupants. The terminology used for these types of rooms and spaces identified on design drawings also has been an issue since this terminology is not referenced or described in any national code or standard. For example, rooms and spaces have been identified on design drawings as huddle rooms, quiet rooms, focus rooms, etc.

Therefore, it is our opinion that Table 1004.5 currently does not adequately address these types of rooms/spaces in open office space environments. To address the concerns and questions, we have proposed alternative occupant load factors for collaboration rooms/spaces. The proposed revision is based on a small field evaluation study of several collaboration rooms having posted occupant loads based on an analysis of the efficiency of use of the space when occupied. That is, having a space with ample room so occupants do not feel cramped and elbow to elbow. It was determined that the occupant load factors for a specific room size corresponding to the posted occupant loads ranged between 28 ft²/person to 32 ft²/person. Therefore, a mean average occupant load factor of 30 ft²/person for collaboration rooms/spaces seemed reasonable and was chosen. In addition, since these collaboration rooms/spaces are used primarily for private meetings between staff, both for small personnel meetings and team meetings, etc. it was felt that the size of these rooms should be limited to address concerns these rooms/spaces will be used as conference rooms. Therefore, based on a review of a number of proposed space layouts having collaboration rooms/spaces, it seemed reasonable to limit the size of these rooms/spaces to less than or equal to 450 ft² in area when using an occupant load factor of 30 ft²/person.

Please remember, these specific rooms/spaces are primarily used by employees to transition temporarily from their regular work-station area in order to obtain privacy and/or to avoid disturbing other employees located in the open office environment. These rooms are not designated as conference rooms and typically are not used for conference rooms and therefore should not be compelled to comply with the more conservative occupant load factors associated with Assembly Use areas. However, currently the IBC does not specifically address an occupant load factor for these types of rooms/spaces. Therefore, some AHJs have classified these rooms/space, regardless of size, as Assembly Use areas and have interpreted that the occupant load factors currently in the IBC require that these rooms/spaces are compelled to use the occupant load factor of 15ft²/person.

Based on our personal experience reviewing space layouts that have incorporated various sized collaboration rooms/spaces and the fact that these rooms/spaces are primarily only used by employees to transition temporarily from their regular work-station area in order to obtain privacy and/or to avoid disturbing other employees located in the open office environment, we believe these rooms/spaces should not be compelled to comply with the more conservative occupant load factors associated with Assembly Use areas since these rooms/spaces are not used as conference rooms.

In summary, we believe the proposed new occupant load factor for business areas collaborative rooms/spaces will not negatively impact the overall safety for building occupants as it relates to the use of the building's means of egress systems during an emergency. In addition, the acknowledgement of collaborative rooms/spaces should also improve design consistency in calculating the occupant loads for these types of work environments as well as providing nationwide consistency among AHJs in the interpretation/enforcement of the appropriate occupant load factor to use for these types of rooms/spaces.

Lastly, please note that the National Fire Protection Association 101, Life Safety Code (2018 edition), has similar requirements to address business use collaboration rooms/spaces.

Bibliography:

National Fire Protection Association (NFPA), 101, Life Safety Code, 2018

Cost Impact

The code change proposal will decrease the cost of construction .

The code change proposed may decrease the cost of construction since collaboration rooms/spaces are primarily only used by employees to transition temporarily from their regular work-station area in order to obtain privacy and/or to avoid disturbing other employees located in the open office environment. Therefore, if these rooms/spaces are compelled to comply with the more conservative occupant load factors associated with Assembly Use areas, the total calculated number of occupants on a floor of the building would increase and may necessitate extra wider exit stairs or additional exit stairs.

Internal ID: 1512

E8-18

IBC: 1004.8, (IFC[BE] 1004.8)

Proponent: David Renn, City and County of Denver, representing Code Change Committee of Colorado Chapter of the ICC (david.renn@denvergov.org)

2018 International Building Code

Revise as follows:

1004.8 Concentrated business use areas. The occupant load factor for concentrated business use shall be applied to telephone call centers, trading floors, electronic data processing centers and similar business use areas with a higher density of occupants than would normally be expected in a typical business occupancy environment. ~~Where approved by the building official, the~~ The occupant load for concentrated business use areas shall be the actual ~~occupant load, where approved by the building official,~~ but not less than one occupant per 50 square feet (4.65 m²) of gross occupiable floor space.

Reason:

As currently written, the first sentence states that the occupant load factor for concentrated business use shall be applied to certain uses, and the second sentence defines what this occupant load factor is to be, including a requirement that it be approved by the building official. If the building official doesn't approve the occupant load factor, it is unclear how occupant loads would be calculated since the first sentence requires the use of this occupant load factor and there is no alternative.

This proposal moves "where approved by the building official" so this phrase applies to the actual occupant load, but not also to the minimum occupant load based on one occupant per 50 SF of gross area. This is appropriate since the actual occupant load is subjective and should be approved by the building official, and the minimum occupant load is a calculated minimum that does not need approval by the building official.

Note that this proposal changes the wording back to what was originally proposed for this new 2018 code section (proposal E 9-15). The "where approved by the building official" phrase was moved by the committee, but no reason statement was given for this move. This committee action, as shown in the 2015 Report of Committee Action Hearing, is shown below for reference:

E 9-15

Committee Action:

Approved as Modified

1004.6 Concentrated business use areas. The occupant load factor for concentrated business use shall be applied to telephone call centers, trading floors, electronic data processing centers and similar business use areas with a higher density of occupants than would normally be expected in a typical business occupancy environment. ~~The~~ Where approved by the code official, the occupant load for concentrated business use areas shall be the actual occupant load, ~~where approved by the code official,~~ but not less than one occupant per ~~100~~ 50 square foot gross of occupiable floor space.

Committee Reason: The modification from 100 sq.ft. per occupant to 50 sq.ft. per occupant as a maximum for concentrated business areas is appropriate. The documentation shows that a worst case scenario of 50 sq.ft. per person occurred in these high density spaces.

The supporting data substantiates an increase for the typical office spaces. There were concerns raised about areas where high costs of space would result in a higher density in an office as well as maintain the occupant load during the life of a building as different tenants change.

Assembly Action :

None

Cost Impact

The code change proposal will not increase or decrease the cost of construction .

This change clarifies the intent of the code.

Internal ID: 1233

E9-18

IBC: 1004.9 (New), (IFC[BE] 1004.9 (New))

Proponent: Stephen Thomas, Colorado Code Consulting, LLC, representing Colorado Chapter ICC
(sthomas@coloradocode.net)

2018 International Building Code

Add new text as follows:

1004.9 Occupant load based on capacity. The occupant load of any room, area, space or story is permitted to be established as the number of occupants for which the existing means of egress is adequate, provided that measures are established to prevent occupancy greater than the number and capacity of the means of egress components.

Revise as follows:

~~1004.9~~**1004.10 Posting of occupant load.** Every room or space that is an assembly occupancy shall have the *occupant load* of the room or space posted in a conspicuous place, near the main *exit* or *exit access doorway* from the room or space, for the intended configurations. Posted signs shall be of an approved legible permanent design and shall be maintained by the owner or the owner's authorized agent.

Reason:

There are many times that the calculated occupant load for a room, area, space or story in an existing building exceeds the total number or capacity of the means of egress. This proposal permits the occupant load to be based on the existing design of the means of egress. For example, a story could not have more than 340 occupants if two doors providing 34 inches of clear width each were provided. Some means of controlling the occupant load would need to be determined. The building official could require that the maximum occupant load be posted as an example. A companion change in the IEBC will be submitted if necessary.

Cost Impact

The code change proposal will decrease the cost of construction .

The cost of adding an additional exit will not be needed for some buildings.

Internal ID: 1070

E10-18

IBC: 1005.7.1, (IFC[BE] 1005.7.1)

Proponent: Keith Flanders, Cosentini Associates, representing self (kflanders@cosentini.com)

2018 International Building Code

Revise as follows:

1005.7.1 Doors. Doors, when fully opened, shall not reduce the required width by more than 7 inches (178 mm). Doors in any position shall not reduce the required width by more than one-half.

Exceptions:

1. Surface-mounted latch release hardware shall be exempt from inclusion in the 7-inch maximum (178 mm) encroachment where both of the following conditions exist:
 - 1.1. The hardware is mounted to the side of the door facing away from the adjacent wall where the door is in the open position.
 - 1.2. The hardware is mounted not less than 34 inches (865 mm) nor more than 48 inches (1219 mm) above the finished floor.
2. Self- or automatic-closing doors shall be exempt from inclusion in the 7-inch maximum (178 mm) encroachment.
3. The restrictions on door swing shall not apply to doors within individual *dwelling units* and *sleeping units* of Group R-2 occupancies and *dwelling units* of Group R-3 occupancies.

Reason:

Door encroachment when the door is fully open is not an issue when the door is provided with an automatic closer or other self closing mechanism since the door will be closing. Accordingly such doors provided with self closing devices will be closed and should not be required to comply with the 7-inch encroachment provisions for when the door is fully open.

Cost Impact

The code change proposal will not increase or decrease the cost of construction .

This is a design option to provide an automatic closing door versus fully complying with the encroachment provisions. Accordingly it does not change the cost of construction.

Internal ID: 1024

E11-18

IBC: 1006.2.1, (IFC[BE] 1006.2.1)

Proponent: Lee Kranz, representing City of Bellevue, WA (lkranz@bellevuewa.gov)

2018 International Building Code

Revise as follows:

1006.2.1 Egress based on occupant load and common path of egress travel distance. Two *exits* or *exit access doorways* from any space shall be provided where the design *occupant load* or the *common path of egress* travel distance exceeds the values *listed* in Table 1006.2.1. The cumulative *occupant load* from adjacent rooms, areas or spaces shall be determined in accordance with Section 1004.2.

1. The number of *exits* from foyers, lobbies, vestibules or similar spaces need not be based on cumulative *occupant loads* for areas discharging through such spaces, but the capacity of the *exits* from such spaces shall be based on applicable cumulative *occupant loads*.
2. *Care suites* in Group I-2 occupancies complying with Section 407.4.
3. Unoccupied mechanical rooms and penthouses are not required to comply with the common path of egress travel distance measurement.

Reason:

Mechanical rooms and penthouses are typically only occupied during routine maintenance or replacement of equipment. There are designs, particularly in existing buildings, where additional exits (including stairways or ramps) are being required due to the length of the common path of travel from these rooms or spaces which is expensive and unnecessary. This code change reduces the effective length of the common path for specific areas rarely used and when it is used the occupant load is minimal.

Cost Impact

The code change proposal will decrease the cost of construction .

If approved this code change will reduce construction costs because the need to construct additional exits will no longer be required for designs where mechanical rooms or penthouses add to the length of the common path of travel.

Internal ID: 91

E12-18

IBC: 1006.2.1, (IFC[BE] 1006.2.1)

Proponent: Todd Snider, West Coast Code Consultants (WC3), representing Self (Todd@KimballEng.com)

2018 International Building Code

Revise as follows:

1006.2.1 Egress based on occupant load and common path of egress travel distance. Two *exits* or *exit access doorways* from any space shall be provided where the design *occupant load* or the *common path of egress* travel distance exceeds the values *listed* in Table 1006.2.1. The cumulative *occupant load* from adjacent rooms, areas or spaces shall be determined in accordance with Section 1004.2.

Exceptions:

1. The number of *exits* from foyers, lobbies, vestibules or similar spaces need not be based on cumulative *occupant loads* for areas discharging through such spaces, but the capacity of the *exits* from such spaces shall be based on applicable cumulative *occupant loads*.
2. *Care suites* in Group I-2 occupancies complying with Section 407.4.
3. One exit or exit access doorway from any space shall be permitted for spaces located on a story permitted a single exit or access to a single exit in accordance with Section 1006.3.3.

Reason:

Proposed revision to add an exception to this Section to provide clarity between the conflicting requirements of IBC Table 1006.2.1 and Tables 1006.3.3(1) and 1006.3.3(2). There are times when IBC 1006.3.3 would allow a single Exit from a story or building but IBC 1006.2.1 would require access to two exits be provided.

Cost Impact

The code change proposal will not increase or decrease the cost of construction .

There is no cost affect. This is clarifying an existing exception.

Internal ID: 1283

E13-18

IBC: 1006.2.2, (IFC[BE] 1006.2.2)

Proponent: Ed Kullik, Chair, representing ICC Building Code Action Committee (bcac@iccsafe.org)

2018 International Building Code

Revise as follows:

1006.2.2 Egress based on use. The numbers, types and locations of *exits* or access to *exits* shall be provided in the uses described in Sections 1006.2.2.1 through 1006.2.2.6.

Reason:

The subsections of 1006.2.2 includes not only the number of exits and exit access doorways, but also requirements regarding the exit and exit access doors, types of exit access, and their locations. This provides clarity in the scoping of this section.

This proposal is submitted by the ICC Building Code Action Committee (BCAC). BCAC was established by the ICC Board of Directors in July 2011 to pursue opportunities to improve and enhance assigned International Codes or portions thereof. In 2017 the BCAC has held 3 open meetings. In addition, there were numerous Working Group meetings and conference calls for the current code development cycle, which included members of the committee as well as any interested party to discuss and debate the proposed changes. Related documentation and reports are posted on the BCAC website at: <https://www.iccsafe.org/codes-tech-support/codes/codedevelopment-process/building-code-action-committee-bcac>.

Cost Impact

The code change proposal will not increase or decrease the cost of construction .

This proposal is a clarification reminder of the scope of requirements included in the identified sections.

Internal ID: 447

E14-18

IBC: 1006.2.2.1, (IFC[BE] 1006.2.2.1)

Proponent: Lawrence Lincoln, Salt Lake City Corporation, representing Self (larry.lincoln@slcgov.com)

2018 International Building Code

Revise as follows:

1006.2.2.1 Boiler, incinerator and furnace rooms. ~~Two exit access doorways are required in boiler, incinerator and furnace rooms where the area is over 500 square feet (46 m²) and any that contain fuel-fired equipment exceeds~~ exceeding 400,000 British thermal units (Btu) (422 000 KJ) input capacity. Where two exit access doorways are required provided, one is permitted to be a fixed ladder or an alternating tread device. Exit access doorways shall be separated by a horizontal distance equal to one-half the length of the maximum overall diagonal dimension of the room.

Exception:A single exit access doorway shall be allowed where the boiler, incinerator and furnace rooms are less than 500 square feet (46 m²) and a minimum 48 inch (1219 mm) clear aisle width is provided around the perimeter of the fuel-fired equipment.

Reason:

The elimination of the over 500 square foot requirement in the general statement and placing it into the exception really doesn't change the basic meaning of the section so far as the square footage requirement is concerned. The exception provides for an additional requirement when a single exit access door is utilized in a 500 square foot or less size room. Since IBC section 1020.2 already requires a minimum width of 24 inches 'to access and utilize mechanical,... systems or equipment', the doubling of the 24 inch required access width (to 48 inches) and reducing the exit access doorway requirement to one, seems reasonable. The logic behind doubling the required equipment access width comes from (NFPA 70) NEC article 110.26 (C) (2) (b). This section of the NEC allows for a single exit from an electrical room when the depth of the working space is doubled.

Cost Impact

The code change proposal will not increase or decrease the cost of construction .

The code proposal will not increase or decrease the cost of construction since the exception added is a trade-off.

Internal ID: 1995

E15-18 Part I

PART 1 - IBC: 1006.2.2.2; (IFC[BE] 1006.2.2)

PART 2 - IMC: 1105.10 [BE] (New)

Proponent: Jeffrey Shapiro, representing International Institute of Ammonia Refrigeration
(jeff.shapiro@intlcodeconsultants.com)

THIS IS A TWO PART CODE CHANGE. PART I WILL BE HEARD BY THE MEANS OF EGRESS COMMITTEE. PART II WILL BE HEARD BY THE MECHANICAL CODE COMMITTEE. SEE THE TENTATIVE HEARING ORDER OF THESE COMMITTEES.

2018 International Building Code

Revise as follows:

1006.2.2.2 Refrigeration machinery rooms. Machinery rooms larger than 1,000 square feet (93 m²) shall have not less than two *exits* or *exit access doorways*. Where two *exit access doorways* are required, one such doorway is permitted to be served by a fixed ladder or an alternating tread device. *Exit access doorways* shall be separated by a horizontal distance equal to one-half the maximum horizontal dimension of the room.

All portions of machinery rooms shall be within 150 feet (45 720 mm) of an *exit* or *exit access doorway*. An increase in *exit access* travel distance is permitted in accordance with Section 1017.1.

Exit and *exit access doorways* shall swing in the direction of egress travel and shall be equipped with panic hardware, regardless of the *occupant load* served. *Exit* and *exit access doorways* shall be tight fitting and self-closing.

Internal ID: 2151

E15-18 Part II

IMC: 1105.10 [BE] (New)

Proponent: Jeffrey Shapiro, representing International Institute of Ammonia Refrigeration
(jeff.shapiro@intlcodeconsultants.com)

2018 International Mechanical Code

Add new text as follows:

1105.10 [BE] Means of egress. Machinery rooms larger than 1,000 square feet (93 m²) shall have not less than two exits or exit access doorways. Where two exit access doorways are required, one such doorway is permitted to be served by a fixed ladder or an alternating tread device. Exit access doorways shall be separated by a horizontal distance equal to one-half the maximum horizontal dimension of the room. All portions of machinery rooms shall be within 150 feet (45 720 mm) of an exit or exit access doorway. An increase in exit access travel distance is permitted in accordance with Section 1017.1. Exit and exit access doorways shall swing in the direction of egress travel and shall be equipped with panic hardware, regardless of the occupant load served. Exit and exit access doorways shall be tight fitting and self-closing.

Reason:

It is appropriate for refrigeration machinery rooms to have panic hardware on means of egress doors to protect occupants because of the risk of a rapid release of hazardous or asphyxiant gases. The need for rapid escape from refrigeration machinery rooms is not unlike what is needed for Group H Occupancies, which are required by Section 1010.1.10 to have panic hardware on all swinging doors. Likewise, IAR 2 includes this requirement for ammonia refrigeration machinery rooms.

It is also recommended that this section be duplicated in the IMC to ensure that the requirements are not overlooked by machinery room designers. The requirement in the IBC is not readily found as a refrigeration machinery room requirement since it is isolated in the means of egress chapter.

Cost Impact

The code change proposal will increase the cost of construction .

For machinery rooms that would not already have been provided with panic hardware on means of egress doors, the requirement to have panic hardware will constitute an increased cost.

Internal ID: 3396

E16-18

IBC: 1006.2.2.4, (IFC[BE] 1006.2.2.4)

Proponent: Lee Kranz, representing City of Bellevue, WA (lkranz@bellevuewa.gov)

2018 International Building Code

Delete without substitution:

~~**1006.2.2.4 Group I-4 means of egress.** Group I-4 facilities, rooms or spaces where care is provided for more than 10 children that are 2¹/₂ years of age or less, shall have access to not less than two exits or exit access doorways.~~

**TABLE 1006.2.1
SPACES WITH ONE EXIT OR EXIT ACCESS DOORWAY**

OCCUPANCY	MAXIMUM OCCUPANT LOAD OF SPACE	MAXIMUM COMMON PATH OF EGRESS TRAVEL DISTANCE (feet)		
		Without Sprinkler System (feet)		With Sprinkler System (feet)
		Occupant Load		
		OL ≤ 30	OL > 30	
A ^c , E, M	49	75	75	75 ^a
B	49	100	75	100 ^a
F	49	75	75	100 ^a
H-1, H-2, H-3	3	NP	NP	25 ^b
H-4, H-5	10	NP	NP	75 ^b
I-1, I-2 ^d , I-4	10	NP	NP	75 ^a
I-3	10	NP	NP	100 ^a
R-1	10	NP	NP	75 ^a
R-2	20	NP	NP	125 ^a
R-3 ^e	20	NP	NP	125 ^{a, g}
R-4 ^e	20	NP	NP	125 ^{a, g}
S ^f	29	100	75	100 ^a
U	49	100	75	75 ^a

For SI: 1 foot = 304.8 mm.

NP = Not Permitted.

- Buildings equipped throughout with an *automatic sprinkler system* in accordance with Section 903.3.1.1 or 903.3.1.2. See Section 903 for occupancies where automatic sprinkler systems are permitted in accordance with Section 903.3.1.2.
- Group H occupancies equipped throughout with an *automatic sprinkler system* in accordance with Section 903.2.5.
- For a room or space used for assembly purposes having fixed seating, see Section 1029.8.
- For the travel distance limitations in Group I-2, see Section 407.4.
- The common path of egress travel distance shall only apply in a Group R-3 occupancy located in a mixed occupancy building.
- The length of common path of egress travel distance in a Group S-2 open parking garage shall be not more than 100 feet.
- For the travel distance limitations in Groups R-3 and R-4 equipped throughout with an *automatic sprinkler system* in accordance with Section 903.3.1.3, see Section 1006.2.2.6.

Reason:

Section 1006.2.2.4 is redundant with Table 1006.2.1 and should be deleted. The maximum occupant load for a space with one exit or exit access doorway for an I-4 in the table is 10 and covers all I-4 uses so there is no need to keep Section 1006.2.2.4.

Cost Impact

The code change proposal will not increase or decrease the cost of construction .

This change deletes a section of the code already covered by Table 1006.2.1 and will not have a financial impact on the cost of construction.

Internal ID: 148

E17-18

IBC: 1006.2.2.4 (New), (IFC[BE] 1006.2.2.4 (New))

Proponent: Ed Kullik, Chair, representing ICC Building Code Action Committee (bcac@iccsafe.org)

2018 International Building Code

Add new text as follows:

1006.2.2.4 Electrical rooms. The location and number of exit or exit access doorways shall be provided for electrical rooms in accordance with Section 110.26 of NFPA 70 for electrical equipment rated 1000V or less, and Section 110.33 of NFPA 70 for electrical equipment rated over 1000V. Panic hardware shall be provided where required in accordance with Section 1010.1.10.1.

Reason:

Section 1006.2.2 provides the specific requirements for the numbers, types, and locations of exits or access to exits for specific uses. Requirements are already provided in Section 1006.2.2.1 for boiler, incinerator and furnace rooms, which is based on the ASME Boiler and Pressure Vessel Code, and Section 1006.2.2.2 for refrigeration machinery rooms, which is based on ASHRAE 15.

The requirements for egress for electrical rooms are not currently addressed in this code, except for where panic or fire exit hardware is used in Section 1010.1.10, which does not provide direction on how many or where the exits or exit access doorways are to be located.

This proposal is submitted by the ICC Building Code Action Committee (BCAC). BCAC was established by the ICC Board of Directors in July 2011 to pursue opportunities to improve and enhance assigned International Codes or portions thereof. In 2017 the BCAC has held 3 open meetings. In addition, there were numerous Working Group meetings and conference calls for the current code development cycle, which included members of the committee as well as any interested party to discuss and debate the proposed changes. Related documentation and reports are posted on the BCAC website at: <https://www.iccsafe.org/codes-tech-support/codes/codedevelopment-process/building-code-action-committee-bcac>.

Cost Impact

The code change proposal will not increase or decrease the cost of construction .

Chapter 27 of the IBC already requires electrical installations to comply with the provisions of NFPA 70. This proposal specifically directs the code user to the applicable requirements for electrical rooms in NFPA 70.

Internal ID: 448

E18-18

IBC: SECTION 1006.3, 1006.3.1, 1019.3 (IFC[BE] 1006.3, 1006.3.1, 1019.3)

Proponent: David Collins, representing The American Institute of Architects (dcollins@preview-group.com)

2018 International Building Code

SECTION 1006 NUMBER OF EXITS AND EXIT ACCESS DOORWAYS

1006.1 General. The number of *exits* or *exit access doorways* required within the *means of egress* system shall comply with the provisions of Section 1006.2 for spaces, including *mezzanines*, and Section 1006.3 for *stories* or occupied roofs.

Revise as follows:

1006.3 Egress from stories or occupied roofs. The *means of egress* system serving any *story* or occupied roof shall be provided with the number of separate and distinct *exits* or access to *exits* based on the aggregate *occupant load* served in accordance with this section. ~~Where *stairways* serve more than one *story*, only the *occupant load* of each *story* considered individually shall be used in calculating the required number of *exits* or access to *exits* serving that *story*.~~

Add new text as follows:

1006.3.1 Occupant load. Where stairways serve more than one story, or more than one story and an occupied roof, only the occupant load of each story or occupied roof, considered individually, shall be used in when calculating the required number of exits or access to exits serving that story.

Revise as follows:

~~1006.3.1~~ ~~1006.3.2~~ **Adjacent story. Path of egress travel.** The path of egress travel to an *exit* shall not pass through more than one adjacent *story*.

Exception: The path of egress travel to an *exit* shall be permitted to pass through more than one adjacent *story* in any of the following:

1. In Group R-1, R-2 or R-3 occupancies, exit access stairways and *ramps* connecting four stories or less serving and contained within an individual dwelling unit, sleeping unit or live/work unit.
2. Exit access stairways serving and contained within a Group R-3 congregate residence or a Group R-4 facility.
3. Exit access stairways and ramps within an atrium comply with the provisions of Section 404.
- ~~4.~~ Exit access stairways and *ramps* in open parking garages that serve only the parking garage.
- ~~5.~~ Exit access stairways and *ramps* serving *open-air assembly seating* complying with the exit access travel distance requirements of Section 1029.7.
- ~~6.~~ Exit access stairways and *ramps* between the balcony, gallery or press box and the main assembly floor in occupancies such as theaters, *places of religious worship*, auditoriums and sports facilities.
7. Exterior exit access stairways and ramps between occupied roofs.

~~1006.3.2~~ **1006.3.3 Egress based on occupant load.** Each *story* and occupied roof shall have the minimum number of separate and distinct *exits*, or access to *exits*, as specified in Table 1006.3.2. A single *exit* or access to a single *exit* shall be permitted in accordance with Section 1006.3.3. The required number of *exits*, or *exit access stairways* or *ramps* providing access to *exits*, from any *story* or occupied roof shall be maintained until arrival at the *exit discharge* or a *public way*.

1019.3 Occupancies other than Groups I-2 and I-3. In other than Group I-2 and I-3 occupancies, floor openings containing *exit access stairways* or *ramps* that do not comply with one of the conditions *listed* in this section shall be enclosed with a shaft enclosure constructed in accordance with Section 713.

1. *Exit access stairways and ramps* that serve or atmospherically communicate between only two stories. Such interconnected stories shall not be open to other stories.
2. In Group R-1, R-2 or R-3 occupancies, *exit access stairways and ramps* connecting four stories or less serving and contained within an individual *dwelling unit* or *sleeping unit* or *live/work unit*.
3. *Exit access stairways* serving and contained within a Group R-3 congregate residence or a Group R-4 facility are not required to be enclosed.
4. *Exit access stairways and ramps* in buildings equipped throughout with an *automatic sprinkler system* in accordance with Section 903.3.1.1, where the area of the vertical opening between stories does not exceed twice the horizontal projected area of the *stairway* or *ramp* and the opening is protected by a draft curtain and closely spaced sprinklers in accordance with NFPA 13. In other than Group B and M occupancies, this provision is limited to openings that do not connect more than four stories.
5. *Exit access stairways and ramps* within an *atrium* complying with the provisions of Section 404.
6. *Exit access stairways and ramps* in *open parking garages* that serve only the parking garage.
7. *Exit access stairways and ramps* serving *smoke-protected* or *open-air assembly seating* complying with the *exit access* travel distance requirements of Section 1029.7.
8. *Exit access stairways and ramps* between the balcony, gallery or press box and the main assembly floor in occupancies such as theaters, *places of religious worship*, auditoriums and sports facilities.
9. Exterior exit access stairways or ramps between occupied roofs.

Reason:

The title of this section includes stories and occupied roof, but the section gives no guidance regarding the occupied roof. This change will clarify the application of the provisions to an occupied roof and another story. As has been the practice, the occupant load of each story or with this change, the occupant load of the roof (which isn't a story) will be used to determine the required occupant load for the stair serving it.

In addition, the two exceptions will recognize an exit access stairway located in an atrium and an exit access stairway serving an occupied roof to pass through more than one story. This change will make it clear that a stair in an atrium that is NOT part of the means of egress is always acceptable and not limited to the one adjacent story criteria.

Cost Impact

The code change proposal will decrease the cost of construction .

This change will simplify design decisions, review and approval of projects, reducing the cost of construction.

Internal ID: 1700

E19-18

IBC: 404.9.3, 1006.3.1, 1017.3, 1023.2, (IFC[BE] 1006.3.1, 1017.3, 1023.2)

Proponent: Ed Kullik, Chair, representing ICC Building Code Action Committee (bcac@iccsafe.org)

2018 International Building Code

404.9 Exit access travel distance. *Exit access* travel distance for areas open to an *atrium* shall comply with the requirements of this section.

404.9.1 Egress not through the atrium. Where required access to the *exits* is not through the *atrium*, *exit access* travel distance shall comply with Section 1017.

404.9.2 Exit access travel distance at the level of exit discharge. Where the path of egress travel is through an *atrium* space, *exit access* travel distance at the *level of exit discharge* shall be determined in accordance with Section 1017.

Revise as follows:

404.9.3 Exit access travel distance at other than the level of exit discharge. Where the path of egress travel is not at the *level of exit discharge* from the *atrium*, that portion of the total permitted *exit access* travel distance that occurs within the *atrium* shall be not greater than 200 feet (60 960 mm). Exit access travel distance shall be measured in accordance with Sections 1006.3.1 and 1017.3.

404.10 Interior exit stairways. Not greater than 50 percent of *interior exit stairways* are permitted to egress through an atrium on the *level of exit discharge* in accordance with Section 1028.

CHAPTER 10 MEANS OF EGRESS

1006.3 Egress from stories or occupied roofs. The *means of egress* system serving any *story* or occupied roof shall be provided with the number of separate and distinct *exits* or access to *exits* based on the aggregate *occupant load* served in accordance with this section. Where *stairways* serve more than one *story*, only the *occupant load* of each *story* considered individually shall be used in calculating the required number of *exits* or access to *exits* serving that *story*.

1006.3.1 Adjacent story. The path of egress travel to an *exit* shall not pass through more than one adjacent *story*.

Exception: The path of egress travel to an *exit* shall be permitted to pass through more than one adjacent *story* in any of the following:

1. In Group R-1, R-2 or R-3 occupancies, exit access stairways and *ramps* connecting four stories or less serving and contained within an individual dwelling unit, sleeping unit or live/work unit.
2. Exit access stairways serving and contained within a Group R-3 congregate residence or a Group R-4 facility.
3. Exit access stairways and ramps within an atrium complying with the provisions of Section 404.
4. Exit access stairways and *ramps* in open parking garages that serve only the parking garage.
- 5.4 Exit access stairways and *ramps* serving *open-air assembly seating* complying with the exit access travel distance requirements of Section 1029.7.
- 6.5 Exit access stairways and *ramps* between the balcony, gallery or press box and the main assembly floor in occupancies such as theaters, *places of religious worship*, auditoriums and sports facilities.

1017.3 Measurement. *Exit access* travel distance shall be measured from the most remote point of each room, area or space along the natural and unobstructed path of horizontal and vertical egress travel to the entrance to an exit.

Exceptions:

1. Within atriums, exit access travel distance is permitted to be measured to the closest riser of an exit access stairway or the closest slope of an exit access ramp.
2. In open parking garages, exit access travel distance is permitted to be measured to the closest riser of an exit access stairway or the closest slope of an exit access ramp.

1017.3.1 Exit access stairways and ramps. Travel distance on *exit access stairways* or *ramps* shall be included in the *exit access* travel distance measurement. The measurement along *stairways* shall be made on a plane parallel and tangent to the *stair tread nosings* in the center of the *stair* and landings. The measurement along *ramps* shall be made on the walking surface in the center of the *ramp* and landings.

1023.2 Construction. Enclosures for interior *exit stairways* and *ramps* shall be constructed as *fire barriers* in accordance with Section 707 or *horizontal assemblies* constructed in accordance with Section 711, or both. *Interior exit stairway* and *ramp* enclosures shall have a fire-resistance rating of not less than 2 hours where connecting four stories or more and not less than 1 hour where connecting less than four stories. The number of stories connected by the interior *exit stairways* or *ramps* shall include any *basements*, but not any *mezzanines*. *Interior exit stairways* and *ramps* shall have a fire-resistance rating not less than the floor assembly penetrated, but need not exceed 2 hours.

Exceptions:

1. *Interior exit stairways* and *ramps* in Group I-3 occupancies in accordance with the provisions of Section 408.3.8.
2. ~~*Interior exit stairways* within an atrium enclosed in accordance with Section 404.6.~~

Reason:

The membership approved E139-12 (AS) which added the allowance for a stairway within an atrium to be considered an exit stairway into Section 1023.2. There is confusion where an atrium is called an exit stairway – how to measure travel distance, what could be in the atrium, if you could travel through an atrium to get to an exit stairway. Section 1019.3 states that open stairways in atriums is an ‘exit access stairway’, so the same stairway is currently called two different things in the code.

The intent of this proposal is to call the open stairway in the atrium an exit access stairway to be consistent with the terminology in Section 1019.3, Item 3.

The revision to Section 404.8.3 is a pointer for where exit access travel distance within an atrium includes travel down an exit access stairway. The revision to Sections 1006.3.1 and 1017.3 are to measure exit access travel distance in a manner that would be consistent with the using the open stairway as a required means of egress off a story consistent with if this stairway was an exit off the floor. The smoke protection provisions for atrium in Section 404 would have to be in place to be able to use this allowance as a required means of egress.

The BCAC also has a proposal to reformat the atrium requirements. If both changes pass, there will be no conflicts. The references to the location of requirements can be correlated.

This proposal is submitted by the ICC Building Code Action Committee (BCAC). BCAC was established by the ICC Board of Directors in July 2011 to pursue opportunities to improve and enhance assigned International Codes or portions thereof. In 2017 the BCAC has held 3 open meetings. In addition, there were numerous Working Group meetings and conference calls for the current code development cycle, which included members of the committee as well as any interested party to discuss and debate the proposed changes. Related documentation and reports are posted on the BCAC website at: <https://www.iccsafe.org/codes-tech-support/codes/codedevelopment-process/building-code-action-committee-bcac>.

Cost Impact

The code change proposal will not increase or decrease the cost of construction .

This proposal is effectively codifying the intent to allow the use of open stairways within an atrium “as if” they are in an exit enclosure due to the enhanced safety that exists within an atrium that complies with all the requirements of IBC Section 404, without applying all the other limitations that exist for an exit enclosure elsewhere in the code.

Internal ID: 452

E20-18

IBC: 1006.3.1, (IFC[BE] 1006.3.1)

Proponent: Ed Kullik, Chair, representing ICC Building Code Action Committee (bcac@iccsafe.org)

2018 International Building Code

1006.3 Egress from stories or occupied roofs. The *means of egress* system serving any *story* or occupied roof shall be provided with the number of separate and distinct *exits* or access to *exits* based on the aggregate *occupant load* served in accordance with this section. Where *stairways* serve more than one *story*, only the *occupant load* of each *story* considered individually shall be used in calculating the required number of *exits* or access to *exits* serving that *story*.

Delete without substitution:

~~**1006.3.1 Adjacent story.** The path of egress travel to an *exit* shall not pass through more than one adjacent *story*.~~

~~**Exception:** The path of egress travel to an *exit* shall be permitted to pass through more than one adjacent *story* in any of the following:~~

- ~~1. In Group R-1, R-2 or R-3 occupancies, exit access stairways and *ramps* connecting four stories or less serving and contained within an individual dwelling unit, sleeping unit or live/work unit.~~
- ~~2. Exit access stairways serving and contained within a Group R-3 congregate residence or a Group R-4 facility.~~
- ~~3. Exit access stairways and *ramps* in open parking garages that serve only the parking garage.~~
- ~~4. Exit access stairways and *ramps* serving open air assembly seating complying with the exit access travel distance requirements of Section 1029.7.~~
- ~~5. Exit access stairways and *ramps* between the balcony, gallery or press box and the main assembly floor in occupancies such as theaters, *places of religious worship*, auditoriums and sports facilities.~~

Reason:

The current list of exceptions allows for exit access stairways within 5 of the 8 options to use travel distance without a story limitation (individual dwelling units(#2), Group R-3 and R-4 congregate residences(#3), open parking garages(#6), open air seating(#7) and balconies(#8)). The 3 options currently limited to one story are the 2 story configuration (#1), water curtains around stairways opening (#4) and atriums (#5). These exceptions were added to the code by E27-15.

Travel distance, rather than stories should be the controlling factor. There would be no impact on two story configurations. Deletion of the requirement would allow for exit access travel distance to be measured down the open exit access stairway, regardless of the number of stories. This would now include open exit access stairways that use water curtains around stairways opening (#4) and atriums with smoke protection (#5). With the removal of the limitation for one story, none of the exceptions are needed.

This would be consistent with the BCAC proposal to revise measurement for travel distance along open exit access stairways in atriums.

This proposal is submitted by the ICC Building Code Action Committee (BCAC). BCAC was established by the ICC Board of Directors in July 2011 to pursue opportunities to improve and enhance assigned International Codes or portions thereof. In 2017 the BCAC has held 3 open meetings. In addition, there were numerous Working Group meetings and conference calls for the current code development cycle, which included members of the committee as well as any interested party to discuss and debate the proposed changes. Related documentation and reports are posted on the BCAC website at: <https://www.iccsafe.org/codes-tech-support/codes/codedevelopment-process/building-code-action-committee-bcac>.

Cost Impact

The code change proposal will decrease the cost of construction .

This will reduce the cost in those situations where an enclosure would have been required for the stairway in buildings with more than two stories.

Internal ID: 526

E21-18

IBC: 1006.3.1, (IFC[BE] 1006.3.1)

Proponent: Gregory Keith, representing The Boeing Company (grkeith@mac.com); Douglas Evans, representing DHE FPE LLC (dhefpe@gmail.com)

2018 International Building Code

Delete and substitute as follows:

~~**1006.3.1 Adjacent story.** The path of egress travel to an exit shall not pass through more than one adjacent story.~~

~~**Exception:** The path of egress travel to an exit shall be permitted to pass through more than one adjacent story in any of the following:~~

- ~~1. In Group R-1, R-2 or R-3 occupancies, exit access stairways and ramps connecting four stories or less serving and contained within an individual dwelling unit, sleeping unit or live/work unit.~~
- ~~2. Exit access stairways serving and contained within a Group R-3 congregate residence or a Group R-4 facility.~~
- ~~3. Exit access stairways and ramps in open parking garages that serve only the parking garage.~~
- ~~4. Exit access stairways and ramps serving open air assembly seating complying with the exit access travel distance requirements of Section 1029.7.~~
- ~~5. Exit access stairways and ramps between the balcony, gallery or press box and the main assembly floor in occupancies such as theaters, places of religious worship, auditoriums and sports facilities.~~

1006.3.1 Access to exits at other levels. In other than Group I-2 and I-3 occupancies, access to exits at other building levels utilizing unenclosed exit access stairways and ramps shall be permitted. Such exit access stairways and ramps shall comply with one or more of the conditions listed in Section 1019.3. Regardless of the number of stories permitted to be served by the unenclosed exit access stairway or ramp, the exit access travel distance to the entrance to an exit shall not exceed the limitations set forth in Section 1017.2.

Reason:

This was the original intent of the ICC Code Technology Committee proposal E5-09/10 that was approved for the 2015 edition of the IBC. The logic was to allow the long established vertical opening exceptions to stand on their own merit.

If these specific conditions have been deemed to provide acceptable fire migration limits, it stands to reason that exit access travel distance may occur within those tenable environments.

However, a separate proposal overlaid the E5 provisions in Section 1006.3 by limiting path of egress travel to an exit only from an adjacent level. This effectively rendered the CTC methodology as moot.

Realizing that the single adjacent story provision was overly restrictive and did not recognize former exit access provisions, five exceptions to the adjacent story requirement were created for the 2018 edition based on the conditions contained in Section 1019.3. Inexplicably, only five of the eight conditions were referenced.

This proposal completes the correction by eliminating the base restriction and the five accompanying exceptions. In doing so, it returns to the original CTC methodology and recognizes all empirical Section 1019.3 fire migration scenarios that have been contained in the IBC and legacy codes for decades. Additionally, it describes the procedure for determining how to access exits at other stories by way of exit access stairways or ramps. Approval of this proposal will allow for the more flexible design of the exit access portion of the means of egress system and achieve more consistent interpretations of the provision.

Cost Impact

The code change proposal will decrease the cost of construction .

The proposal will allow for access to exits by unenclosed exit access stairways in atriums and buildings with specifically protected vertical openings

Staff Note: Section 1006.3.1 was added to the 2018 IBC by code proposal E27-15.

E22-18

IBC: SECTION TABLE 1006.3.2, TABLE 1006.3.3(1), TABLE 1006.3.3(2), (IFC[BE] TABLE 1006.3.2, TABLE 1006.3.3(1), TABLE 1006.3.3(2))

Proponent: Ed Kullik, Chair, representing ICC Building Code Action Committee (bcac@iccsafe.org)

2018 International Building Code

Revise as follows:

SECTION 1006 NUMBER OF EXITS AND EXIT ACCESS DOORWAYS

1006.3 Egress from stories or occupied roofs. The *means of egress* system serving any *story* or occupied roof shall be provided with the number of separate and distinct *exits* or access to *exits* based on the aggregate *occupant load* served in accordance with this section. Where *stairways* serve more than one *story*, only the *occupant load* of each *story* considered individually shall be used in calculating the required number of *exits* or access to *exits* serving that *story*.

1006.3.2 Egress based on occupant load. Each *story* and occupied roof shall have the minimum number of separate and distinct *exits*, or access to *exits*, as specified in Table 1006.3.2. A single *exit* or access to a single *exit* shall be permitted in accordance with Section 1006.3.3. The required number of *exits*, or *exit access stairways* or *ramps* providing access to *exits*, from any *story* or occupied roof shall be maintained until arrival at the *exit discharge* or a *public way*.

**TABLE 1006.3.2
MINIMUM NUMBER OF EXITS OR ACCESS TO EXITS PER STORY OR OCCUPIED ROOF**

OCCUPIED LOAD PER STORY	MINIMUM NUMBER OF EXITS OR ACCESS TO EXITS FROM PER STORY OR OCCUPIED ROOF
1-500	2
501-1,000	3
More than 1,000	4

1006.3.3 Single exits. A single *exit* or access to a single *exit* shall be permitted from any *story* or occupied roof where one of the following conditions exists:

1. The *occupant load*, number of *dwelling units* and common path of egress travel distance do not exceed the values in Table 1006.3.3(1) or 1006.3.3(2).
2. Rooms, areas and spaces complying with Section 1006.2.1 with *exits* that discharge directly to the exterior at the *level of exit discharge*, are permitted to have one *exit* or access to a single *exit*.
3. Parking garages where vehicles are mechanically parked shall be permitted to have one *exit* or access to a single *exit*.
4. Group R-3 and R-4 occupancies shall be permitted to have one *exit* or access to a single *exit*.
5. Individual single-story or multistory *dwelling units* shall be permitted to have a single *exit* or access to a single *exit* from the *dwelling unit* provided that both of the following criteria are met:
 - 5.1. The *dwelling unit* complies with Section 1006.2.1 as a space with one *means of egress*.
 - 5.2. Either the *exit* from the *dwelling unit* discharges directly to the exterior at the *level of exit discharge*, or the *exit access* outside the *dwelling unit's* entrance door provides access to not less than two *approved independent exits*.

**TABLE 1006.3.3(1)
STORIES AND OCCUPIED ROOFS WITH ONE EXIT OR ACCESS TO ONE EXIT FOR R-2 OCCUPANCIES**

<u>STORY AND OCCUPIED ROOF</u>	OCCUPANCY	MAXIMUM NUMBER OF DWELLING UNITS	MAXIMUM COMMON PATH OF EGRESS TRAVEL DISTANCE
Basement, first, second or third story above grade plane	R-2 ^{a, b}	4 dwelling units	125 feet
<u>Occupied roof over the first, second or third story above grade plane</u>	R-2 ^{a, b}	NA	<u>125 feet</u>
Fourth story above grade plane and higher	NP	NA	NA

For SI: 1 foot = 3048 mm.

NP = Not Permitted.

NA = Not Applicable.

- a. Buildings classified as Group R-2 equipped throughout with an *automatic sprinkler system* in accordance with Section 903.3.1.1 or 903.3.1.2 and provided with *emergency escape and rescue openings* in accordance with Section 1030.
- b. This table is used for R-2 occupancies consisting of *dwelling units*. For R-2 occupancies consisting of *sleeping units*, use Table 1006.3.3(2).

TABLE 1006.3.3(2)
STORIES AND OCCUPIED ROOFS WITH ONE EXIT OR ACCESS TO ONE EXIT FOR OTHER OCCUPANCIES

<u>STORY AND OCCUPIED ROOF</u>	OCCUPANCY	MAXIMUM OCCUPANT LOAD PER STORY AND OCCUPIED ROOF	MAXIMUM COMMON PATH OF EGRESS TRAVEL DISTANCE (feet)
First story above or below grade plane and <u>occupied roofs over the first story above grade plane</u>	A, B ^b , E F ^b , M, U	49	75
	H-2, H-3	3	25
	H-4, H-5, I, R-1, R-2 ^{a, c}	10	75
	S ^{b, d}	29	75
Second story above grade plane and <u>occupied roof over the second story above grade plane</u>	B, F, M, S ^d	29	75
Third story above grade plane and higher	NP	NA	NA

For SI: 1 foot = 304.8 mm.

NP = Not Permitted.

NA = Not Applicable.

- a. Buildings classified as Group R-2 equipped throughout with an *automatic sprinkler system* in accordance with Section 903.3.1.1 or 903.3.1.2 and provided with *emergency escape and rescue openings* in accordance with Section 1030.
- b. Group B, F and S occupancies in buildings equipped throughout with an *automatic sprinkler system* in accordance with Section 903.3.1.1 or on the roof of such buildings shall have a maximum *exit access* travel distance of 100 feet.
- c. This table is used for R-2 occupancies consisting of *sleeping units*. For R-2 occupancies consisting of *dwelling units*, use Table 1006.3.3(1).
- d. The length of *exit access* travel distance in a Group S-2 *open parking garage* shall be not more than 100 feet.

Reason:

This is part of a series of 3 proposals dealing with occupied roofs. See BCAC proposals to the definition of penthouse and Section 1009.

The change to the title and heading in Table 1006.3.2 is for consistency with the text.

The proposed modifications to Section 1006 includes adding 'occupied roofs' to Table 1006.3.3(1) to clarify the conditions in which one exit or access to one exit is allowed for Group R-2 occupancies. The tables are modified to clarify that the occupied roofs are allowed 'over the allowable stories.'

Similarly this proposal adds 'occupied roofs' to Table 1006.3.3(2) to clarify the conditions in which one exit or access to one exit is allowed for the other occupancies. The table was also modified to clarify that the occupied roofs are allowed 'over the allowable stories.' A proposed modification to footnote b of the table clarifies that the allowable increase in exit access travel distance from 75 feet to 100 feet for properly sprinklered Group B, F and S occupancies also includes the roof area for these uses.

This proposal is submitted by the ICC Building Code Action Committee (BCAC). BCAC was established by the ICC Board of Directors in July 2011 to pursue opportunities to improve and enhance assigned International Codes or portions thereof. In 2017 the BCAC has held 3 open meetings. In addition, there were numerous Working Group meetings and conference calls for the current code development cycle, which included members of the committee as well as any interested party to discuss and debate the proposed changes. Related documentation and reports are posted on the BCAC website at: <https://www.iccsafe.org/codes-tech-support/codes/codedevelopment-process/building-code-action-committee-bcac>.

Cost Impact

The code change proposal will not increase or decrease the cost of construction .

This proposal provides clarification to a subject that was not previously addressed. The changes to the single occupant tables could allow for one exit stairway from an occupied roof instead of two.

Internal ID: 520

E23-18

IBC: 1006.3.3, (IFC[BE] 1006.3.3)

Proponent: Micah Chappell, representing City of Seattle (micah.chappell@seattle.gov)

2018 International Building Code

Revise as follows:

1006.3.3 Single exits. A single *exit* or access to a single *exit* shall be permitted from any *story* or occupied roof where one of the following conditions exists:

1. The *occupant load*, number of *dwelling units* and common path of egress travel distance within the portion of the building served by the single exit do not exceed the values in Table 1006.3.3(1) or 1006.3.3(2).
2. Rooms, areas and spaces complying with Section 1006.2.1 with *exits* that discharge directly to the exterior at the *level of exit discharge*, are permitted to have one *exit* or access to a single *exit*.
3. Parking garages where vehicles are mechanically parked shall be permitted to have one *exit* or access to a single *exit*.
4. Group R-3 and R-4 occupancies shall be permitted to have one *exit* or access to a single *exit*.
5. Individual single-story or multistory *dwelling units* shall be permitted to have a single *exit* or access to a single *exit* from the *dwelling unit* provided that both of the following criteria are met:
 - 5.1. The *dwelling unit* complies with Section 1006.2.1 as a space with one *means of egress*.
 - 5.2. Either the exit from the *dwelling unit* discharges directly to the exterior at the *level of exit discharge*, or the *exit access* outside the *dwelling unit's* entrance door provides access to not less than two *approved independent exits*.

Reason:

This change allows single exits to serve multiple and separate, egress-independent portions of the same building, as long as the single exit conditions per Table 1006.3.3(1) or 1006.3.3(2) are met within that portion.

Cost Impact

The code change proposal will not increase or decrease the cost of construction .

This proposal allows for more flexibility in the configuration of the exits and exit access within the building, and will not increase the cost of construction.

Internal ID: 1688

E24-18

IBC: 1006.3.3, TABLE 1006.3.3(1), TABLE 1006.3.3(2), (IFC[BE] 1006.3.3, TABLE 1006.3.3(1), TABLE 1006.3.3(2))

Proponent: Ed Kullik, Chair, representing ICC Building Code Action Committee (bcac@iccsafe.org)

2018 International Building Code

Revise as follows:

1006.3.3 Single exits. A single *exit* or access to a single *exit* shall be permitted from any *story* or occupied roof where one of the following conditions exists:

1. The *occupant load*, number of *dwelling units* and ~~common path of egress~~ exit access travel distance do not exceed the values in Table 1006.3.3(1) or 1006.3.3(2).
2. Rooms, areas and spaces complying with Section 1006.2.1 with *exits* that discharge directly to the exterior at the *level of exit discharge*, are permitted to have one *exit* or access to a single *exit*.
3. Parking garages where vehicles are mechanically parked shall be permitted to have one *exit* or access to a single *exit*.
4. Group R-3 and R-4 occupancies shall be permitted to have one *exit* or access to a single *exit*.
5. Individual single-story or multistory *dwelling units* shall be permitted to have a single *exit* or access to a single *exit* from the *dwelling unit* provided that both of the following criteria are met:
 - 5.1. The *dwelling unit* complies with Section 1006.2.1 as a space with one *means of egress*.
 - 5.2. Either the *exit* from the *dwelling unit* discharges directly to the exterior at the *level of exit discharge*, or the *exit access* outside the *dwelling unit's* entrance door provides access to not less than two *approved independent exits*.

**TABLE 1006.3.3(1)
STORIES WITH ONE EXIT OR ACCESS TO ONE EXIT FOR R-2 OCCUPANCIES**

STORY	OCCUPANCY	MAXIMUM NUMBER OF DWELLING UNITS	MAXIMUM COMMON PATH OF EGRESS <u>EXIT ACCESS</u> TRAVEL DISTANCE
Basement, first, second or third story above grade plane	R-2 ^{a, b}	4 dwelling units	125 feet
Fourth story above grade plane and higher	NP	NA	NA

For SI: 1 foot = 3048 mm.

NP = Not Permitted.

NA = Not Applicable.

- a. Buildings classified as Group R-2 equipped throughout with an *automatic sprinkler system* in accordance with Section 903.3.1.1 or 903.3.1.2 and provided with *emergency escape and rescue openings* in accordance with Section 1030.
- b. This table is used for R-2 occupancies consisting of *dwelling units*. For R-2 occupancies consisting of *sleeping units*, use Table 1006.3.3(2).

**TABLE 1006.3.3(2)
STORIES WITH ONE EXIT OR ACCESS TO ONE EXIT FOR OTHER OCCUPANCIES**

STORY	OCCUPANCY	MAXIMUM OCCUPANT LOAD PER STORY	MAXIMUM COMMON PATH OF EGRESS EXIT ACCESS TRAVEL DISTANCE (feet)
First story above or below grade plane	A, B ^b , E F ^b , M, U	49	75
	H-2, H-3	3	25
	H-4, H-5, I, R-1, R-2 ^{a, c}	10	75
	S ^{b, d}	29	75
Second story above grade plane	B, F, M, S ^d	29	75
Third story above grade plane and higher	NP	NA	NA

For SI: 1 foot = 304.8 mm.

NP = Not Permitted.

NA = Not Applicable.

- a. Buildings classified as Group R-2 equipped throughout with an *automatic sprinkler system* in accordance with Section 903.3.1.1 or 903.3.1.2 and provided with *emergency escape and rescue openings* in accordance with Section 1030.
- b. Group B, F and S occupancies in buildings equipped throughout with an *automatic sprinkler system* in accordance with Section 903.3.1.1 shall have a maximum *exit access* travel distance of 100 feet.
- c. This table is used for R-2 occupancies consisting of *sleeping units*. For R-2 occupancies consisting of *dwelling units*, use Table 1006.3.3(1).
- d. The length of *exit access* travel distance in a Group S-2 *open parking garage* shall be not more than 100 feet.

Reason:

There is a conflict in terminology used for single exit criteria for stories/buildings in the IBC Section/Tables 1006.3.3 and IEBC Section/Tables 805.3.1.1. The intent of this proposal is a clarification, without technical revisions.

Below is the definition for common path of egress travel and exit access and a graphic from the IBC commentary illustrating the terms. Single exit stories/buildings cannot have a common path of egress travel since two exits are not required. The correct term is "exit access travel distance". This would match the terminology in the column headings for single exit tables with the footnotes for the single exit tables in the IBC and the table heading and footnotes in the IEBC.

If you look at the history for the single exit tables, until the reorganization that combined single exit spaces and stories, the term used was 'exit access travel distance.'

With the text incorrectly used in IBC Section 1006.3.3, it could be interpreted that the travel distance has to be to a place where there are two exits - which is on the ground floor - regardless if the stairway is an exit access or exit stairway. Exit access travel distance should stop at the door to the exit stairway.

COMMON PATH OF EGRESS TRAVEL. That portion of the exit access travel distance measured from the most remote point within a story to that point where the occupants have separate access to two exits or exit access doorways.

EXIT ACCESS. That portion of a means of egress system that leads from any occupied portion of a building or structure to an exit.

This proposal is submitted by the ICC Building Code Action Committee (BCAC). BCAC was established by the ICC Board of Directors in July 2011 to pursue opportunities to improve and enhance assigned International Codes or portions

thereof. In 2017 the BCAC has held 3 open meetings. In addition, there were numerous Working Group meetings and conference calls for the current code development cycle, which included members of the committee as well as any interested party to discuss and debate the proposed changes. Related documentation and reports are posted on the BCAC website at: <https://www.iccsafe.org/codes-tech-support/codes/codedevelopment-process/building-code-action-committee-bcac>.

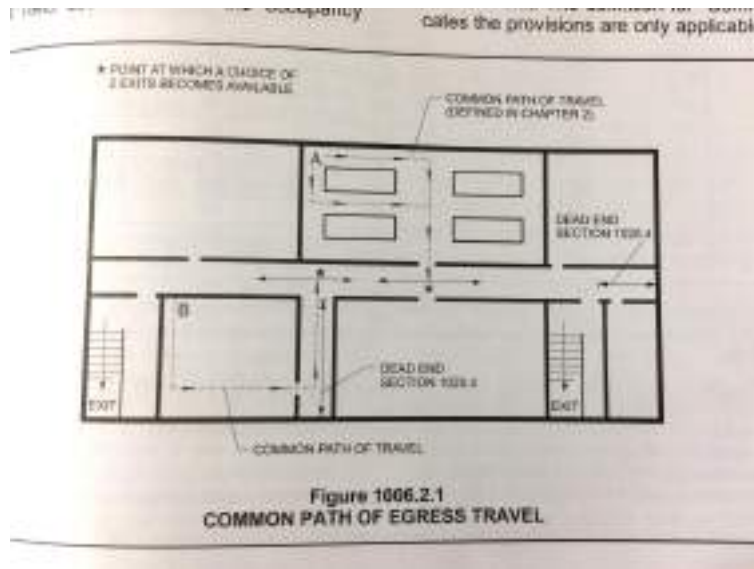

Figure 1006.2.1 from IBC Commentary

Cost Impact

The code change proposal will not increase or decrease the cost of construction .

As the proposal essentially provides clarification to a subject that has created confusion.

Internal ID: 453

E25-18

IBC: 708.1, 708.4.1, 1007.1.1 (IFC[BE] 1007.1.1)

Proponent: Lee Kranz, representing Washington Association of Building Officials Technical Code Development Committee (lkranz@bellevuewa.gov)

2018 International Building Code

Revise as follows:

1007.1.1 Two exits or exit access doorways. Where two *exits, exit access doorways, exit access stairways or ramps*, or any combination thereof, are required from any portion of the *exit access*, they shall be placed a distance apart equal to not less than one-half of the length of the maximum overall diagonal dimension of the building or area to be served measured in a straight line between them. Interlocking or *scissor stairways* shall be counted as one *exit stairway*.

Exceptions:

1. Where interior *exit stairways* or *ramps* are interconnected by a 1-hour fire-resistance-rated *corridor* conforming to the requirements of Section 1020, the required exit separation shall be measured along the shortest direct line of travel within the corridor.
2. Where a building is equipped throughout with an *automatic sprinkler system* in accordance with Section 903.3.1.1 or 903.3.1.2, the separation distance shall be not less than one-third of the length of the maximum overall diagonal dimension of the area served.
3. Group B tenant spaces required to have two means of egress are not required to comply with the dispersion requirements for those means of egress where all of the following are met:
 - 3.1. Interior The tenant space is separated into two areas by fire partitions complying with Section 708 with a minimum fire-resistance-rating of 1/2 hour.
 - 3.2. Each such separated area shall comply with Section 1006.2.1 as a space with one means of egress.
 - 3.2. Each such separated area shall have means of egress independent of any adjoining separated area.

708.1 General. The following wall assemblies shall comply with this section.

1. Separation walls as required by Section 420.2 for Group I-1 and Group R occupancies.
2. Walls separating tenant spaces in *covered and open mall buildings* as required by Section 404.4.2.1.
3. Corridor walls as required by Section 1020.1.
4. Enclosed elevator lobby separation as required by Section 3006.2.
5. Egress balconies as required by Section 1021.2.
6. Walls separating Group B tenant spaces as required by Section 1007.1.1.

708.4.1 Supporting construction. The supporting construction for a *fire partition* shall have a *fire-resistance rating* that is equal to or greater than the required fire-resistance rating of the supported *fire partition*.

Exception: In buildings of Types IIB, IIIB and VB construction, the supporting construction requirement shall not apply to fire partitions separating tenant spaces in covered and open mall buildings, fire partitions separating Group B tenant spaces, fire partitions separating dwelling units, fire partitions separating sleeping units and fire partitions serving as corridor walls.

Reason:

When an office space is located near the end of a corridor in an existing building and two means of egress are required from the tenant space, exit separation within the tenant space may be difficult or impossible to achieve. To mitigate this situation this proposal provides an exception to effectively separate one office tenant space into two (or more) thereby eliminating the need for separation between the two required exits or exit accesses. Some building officials may accept a solution like this using an alternative materials, design and methods of construction process but wouldn't it be better to have it in the code so there is a consistent application? This scenerio occurs on a regular basis in my jurisdiction so a policy was developed consistent with this proposal. We have been using this solution for many

years and it has saved many hours of debate as to how this problem should be solved.

Cost Impact

The code change proposal will decrease the cost of construction .

The cost of construction will be reduced because the need to install a new exit when the existing exit spread is too narrow will be reduced. There may be some additional costs associated with installation of a new fire partition that may not have been planned for in the design.

Internal ID: 149

E26-18

IBC: 1008.2, (IFC[BE] 1008.2)

Proponent: Lee Kranz, representing City of Bellevue, WA (lkranz@bellevuewa.gov)

2018 International Building Code

Revise as follows:

1008.2 Illumination required. The *means of egress* serving a room or space shall ~~be~~ have the capability of being illuminated at all times that the room or space is occupied.

Exceptions:

1. Occupancies in Group U.
2. *Aisle accessways* in Group A.
3. *Dwelling units* and *sleeping units* in Groups R-1, R-2 and R-3.
4. *Sleeping units* of Group I occupancies.

Reason:

The building code is premised on the concept that all of its provisions are enforceable but Section 1008.2 is not. There are times (like after hours or on the weekend) when there may be someone in the building but they don't want the lights on. Another example is processes that require that the lights are off such as film processing in a darkroom. Technically it's a code violation to be in a room or space with the lights off. The proposed language more accurately reflects the role of the code to require the option for occupants to illuminate the MOE.

Cost Impact

The code change proposal will decrease the cost of construction .

This code change will have minimal affect on the cost of construction but it may actually reduce costs after the building is completed. It simply changes the requirement to have the lights on at all times the building is occupied to say that occupants must have the option to turn on the lights. Maybe the electric bill will go down as a result.

Internal ID: 173

E27-18

IBC: 1008.2.1, (IFC[BE] 1008.2.1)

Proponent: Dawn Anderson, representing self (gonedawning@yahoo.com); Dan Buuck, representing National Association of Home Builders (dbuuck@nahb.org); David Collins, representing the American Institute of Architects (dcollins@preview-group.com); Marsha Mazz, representing U.S. Access Board (mazz@Access-Board.gov); Dominic Marinelli, representing United Spinal Association (DMarinelli@accessibility-services.com)

2018 International Building Code

Revise as follows:

1008.2.1 Illumination level under normal power. The *means of egress* illumination level shall be not less than 1 footcandle (11 lux) at the walking surface. Along exit access stairways, exit stairways and at their required landings, the illumination level shall not be less than 10 footcandles at the walking surface when the stairway is in use.

Exception: For auditoriums, theaters, concert or opera halls and similar assembly occupancies, the illumination at the walking surface is permitted to be reduced during performances by one of the following methods provided that the required illumination is automatically restored upon activation of a premises' *fire alarm system*:

1. Externally illuminated walking surfaces shall be permitted to be illuminated to not less than 0.2 footcandle (2.15 lux).
2. Steps, landings and the sides of *ramps* shall be permitted to be marked with self-luminous materials in accordance with Sections 1025.2.1, 1025.2.2 and 1025.2.4 by systems *listed* in accordance with UL 1994.

Reason:

The Illuminating Engineering Society (IES) provide recommendations for the foot candle levels to ensure adequate illumination and safety for occupants in common areas to assist in achieving appropriate light levels with the greatest energy efficiency dependent on the occupancy and the level of detailed work. The recommended range for general circulation for average maintained foot candles is 10-30 foot candles. The intent of this provision is to provide the minimum recommended lighting on stairways so that the walking surface is visible. Persons with low vision, or those who are elderly may benefit from higher levels, but that is left for a best design practice. By saying "when the stairway is in use", the intent is to allow for light switches at each floor level landing or motion sensors. It is not intended for the stairway to be illuminated to this level at all times the building is occupied. By saying "exit access and exit stairways" this is not intended to apply to steps in the exit discharge. By placing the requirement here, the intent is to continue to allow the exception for theaters during performances.

Cost Impact

The code change proposal will increase the cost of construction .

Costs, however, will be minimal. NFPA 1 and 101 already require new stairs to have 10 foot-candles min. of illumination on the walking surface when the stairs are in use. Chapter 10 already requires exit access stairways, exit stairways, and their landings to provide 1 foot candle. Energy costs are minimal because the lighting need only be active when the space is in use and automatic dimmers are permitted allowing daylighting to supplement artificial lighting.

Internal ID: 539

E28-18

IBC: 412.7.3, 1008.3.1, 1008.3.2, 1010.1.4.5 (IFC[BE] 1008.3.1, 1008.3.2, 1010.1.4.5)

Proponent: Gregory Keith, representing The Boeing Company (grkeith@mac.com)

2018 International Building Code

412.7.3 Means of egress. The *means of egress* from *heliports* and *helistops* shall comply with the provisions of Chapter 10. Landing areas located on buildings or structures shall have two or more ~~*means of egress, exits or access to exits.*~~ For landing areas less than 60 feet (18 288 mm) in length or less than 2,000 square feet (186 m²) in area, the second *means of egress* is permitted to be a fire escape, *alternating tread device* or ladder leading to the floor below.

Revise as follows:

1008.3.1 General. In the event of power supply failure in rooms and spaces that require two or more ~~*means of egress, exits or access to exits,*~~ an emergency electrical system shall automatically illuminate all of the following areas:

1. *Aisles.*
2. *Corridors.*
3. *Exit access stairways and ramps.*

1008.3.2 Buildings. In the event of power supply failure in buildings that require two or more ~~*means of egress, exits or access to exits,*~~ an emergency electrical system shall automatically illuminate all of the following areas:

1. *Interior exit access stairways and ramps.*
2. *Interior and exterior exit stairways and ramps.*
3. *Exit passageways.*
4. Vestibules and areas on the level of discharge used for *exit discharge* in accordance with Section 1028.1.
5. Exterior landings as required by Section 1010.1.6 for *exit doorways* that lead directly to the *exit discharge*.

1010.1.4.5 Security grilles. In Groups B, F, M and S, horizontal sliding or vertical security grilles are permitted at the main exit and shall be openable from the inside without the use of a key or special knowledge or effort during periods that the space is occupied. The grilles shall remain secured in the full-open position during the period of occupancy by the general public. Where two or more ~~*means of egress, exits or access to exits*~~ are required, not more than one-half of the *exits* or *exit access doorways* shall be equipped with horizontal sliding or vertical security grilles.

Reason:

The International Building Code does not require multiple means of egress. Occasionally, a given building may be served by two or more means of egress systems, but that is the building designer's option, not a code requirement.

This is residual legacy language that has been updated in most Chapter 10 provisions. Emergency electrical system means of egress illumination should be required when two or more exits or access to exits is required. This proposal should be regarded as editorial.

Cost Impact

The code change proposal will not increase or decrease the cost of construction .

This proposal is editorial in nature.

Internal ID: 1611

E29-18

IBC: 1009.2.1, (IFC[BE] 1009.2.1)

Proponent: Ed Kullik, Chair, representing ICC Building Code Action Committee (bcac@iccsafe.org)

2018 International Building Code

Revise as follows:

1009.2.1 Elevators required. In buildings where a required *accessible* floor is four or more stories above or below a *level of exit discharge*, not less than one required *accessible means of egress* shall be an elevator complying with Section 1009.4. For purposes of determining where an elevator is required for accessible means of egress, in buildings equipped throughout with an automatic sprinkler system installed in accordance with Section 903.3.1.1 or 903.3.1.2, an occupied roof shall not be considered a story.

Exceptions:

1. In buildings equipped throughout with an *automatic sprinkler system* installed in accordance with Section 903.3.1.1 or 903.3.1.2, the elevator shall not be required on floors provided with a *horizontal exit* and located at or above the *levels of exit discharge*.
2. In buildings equipped throughout with an *automatic sprinkler system* installed in accordance with Section 903.3.1.1 or 903.3.1.2, the elevator shall not be required on floors provided with a *ramp* conforming to the provisions of Section 1012.

Reason:

This is part of a series of 3 proposals dealing with occupied roofs. See BCAC proposals to the definition of penthouse and Section 1006.

This is NOT for when an accessible route is required to an occupied roof. That is already addressed in Section 1104.4. This is ONLY for when an elevator would be required to serve as part of an accessible means of egress, and thus add a requirement for standby power. This allowance would only be applicable where there was an occupied roof on a 4 story building. If there is an occupied roof on any taller buildings, unless those buildings meet one of the other exceptions for ramps or horizontal exits, standby power would be required to all floors, including the occupied roof. The roof is required to be open to the outside, so there is not the accumulation for smoke that would be found on a typical interior floor – so that offers extra passive protection of occupants on the roof. Therefore, there did not seem to be any justification to require standby power for this limited situation. The stairways would still be required to comply with Section 1009 for accessible means of egress from the roof.

This proposal reinforces the concept that an occupied roof is not a story for the purpose of determining that an elevator is required as an accessible means of egress in properly sprinklered buildings.

This proposal is submitted by the ICC Building Code Action Committee (BCAC). BCAC was established by the ICC Board of Directors in July 2011 to pursue opportunities to improve and enhance assigned International Codes or portions thereof. In 2017 the BCAC has held 3 open meetings. In addition, there were numerous Working Group meetings and conference calls for the current code development cycle, which included members of the committee as well as any interested party to discuss and debate the proposed changes. Related documentation and reports are posted on the BCAC website at: <https://www.iccsafe.org/codes-tech-support/codes/codedevelopment-process/building-code-action-committee-bcac>.

Cost Impact

The code change proposal will not increase or decrease the cost of construction .

This clarifies that standby power is not required for an elevator serving an occupied roof on a 4 story building. Without this clarification, if standby power was required, that would be a significant cost increase.

Internal ID: 522

E30-18

IBC: 1009.2.1, (IFC[BE] 1009.2.1)

Proponent: Micah Chappell, representing City of Seattle (micah.chappell@seattle.gov)

2018 International Building Code

Revise as follows:

1009.2.1 Elevators required. In buildings where a required *accessible* floor or occupied roof is four or more stories above or below a *level of exit discharge*, not less than one required *accessible means of egress* shall be an elevator complying with Section 1009.4.

Exceptions:

1. In buildings equipped throughout with an *automatic sprinkler system* installed in accordance with Section 903.3.1.1 or 903.3.1.2, the elevator shall not be required on floors provided with a *horizontal exit* and located at or above the *levels of exit discharge*.
2. In buildings equipped throughout with an *automatic sprinkler system* installed in accordance with Section 903.3.1.1 or 903.3.1.2, the elevator shall not be required on floors provided with a *ramp* conforming to the provisions of Section 1012.

Reason:

The code recognizes that there are practical limits to complete reliance on assisted evacuation of building occupants by fire personnel because of the limited availability of trained personnel or special devices. As a result, current ICC language requires an elevator be part of the accessible means of egress starting with the 4th story above the level of exit discharge (See 1009.2.1). Occupied roofs at the same level do not currently have this same requirement. The vertical travel distance encountered by a fire fighter performing an assisted rescue is the same whether the occupants are on an occupied roof on the 4th floor above the level of exit discharge or whether they are on the floor of the 4th story above the level of exit discharge within the building. As occupied roofs become more popular this becomes more of an issue for building departments around the country.

Occupied roofs at four or more stories above the level of exit discharge should be treated like occupied floors at the same level in the building. The occupant loads and hazards are similar between occupied roofs and occupied floors, the benefits to occupants and fire personnel from an elevator with emergency back-up power are similar, and a similar approach has been taken in other sections of the building code (see IBC Chapter 10 1006.3, 1006.3.2, and 1006.3.3). The 2018 IBC 1104.4 also requires at least one accessible route to each accessible story, mezzanine and occupied roof in multilevel buildings and facilities. If the requirements for an accessible route to the accessible level treat the occupied roof and accessible floor in the same manner, it is logical to conclude that the same level of protection for the accessible means of egress from an occupied roof should be required.

Cost Impact

The code change proposal will not increase or decrease the cost of construction .

This proposal clarifies the current intent of the accessible means of egress provisions of IBC 1009.2.1. The added language clarifies that an area of refuge and emergency power/legally required standby power must be provided per IBC 1009.4 for an occupied roof that is four or more stories above the level of exit discharge.

No fiscal impact.

Internal ID: 1690

E31-18

IBC: 1009.2.2 (New), (IFC[BE] 1009.2.2 (New))

Proponent: Gene Boecker, representing Code Consultants, Inc. (geneb@codeconsultants.com)

2018 International Building Code

Add new text as follows:

1009.2.2 Separation of means of egress. Where more than one accessible means of egress is required, the entrance to at least two of the exits, stairways or elevators serving as part of the accessible means of egress shall be separated by a distance not less than 30 feet (9144 mm).

Reason:

Because the elevator can serve as a component of the accessible means of egress, a standard core design with stairways at the opposite sides of the core and elevators in the middle will not allow a traditional remoteness application for the accessible means of egress. However, some separation should be required so that the possibility of a single event preventing egress is limited. The language is similar to that in Section 403.5.1 for remoteness of interior exit stairways in high rise buildings. In the case where multiple accessible means of egress are provided, the separation would apply to at least two of them.

Cost Impact

The code change proposal will increase the cost of construction .

The possibility exists that some building configurations will need to be revised to accomodate this remoteness. In reality, it is unlikely that any measureable increase will exist for most buildings.

Internal ID: 1228

E32-18

IBC: 1009.4, 1009.4.3 (New), (IFC[BE] 1009.4, 1009.4.3)

Proponent: Gene Boecker, representing Code Consultants, Inc. (geneb@codeconsultants.com)

2018 International Building Code

Revise as follows:

1009.4 Elevators. In order to be considered part of an *accessible means of egress*, an elevator shall comply with Sections 1009.4.1 and ~~1009.4.2 through 1009.4.3.~~

Add new text as follows:

1009.4.3 Location. Where multiple elevators serve as more than one of the accessible means of egress, the elevators serving as different accessible means of egress must be provided with separate operating systems in accordance with Section 3003 and be located in separate elevator banks.

Reason:

The provisions for elevators as accessible means of egress were written assuming only one group of elevators in a building. The second means of egress would always be a stairway. Literally, there is no limitation of how many elevators can be used to fulfil the requirement in Section 1009.1 for multiple accessible means of egress. It is reasonable to require some separation between elevators if the option selected is to use elevators for all the accessible means of egress. These elevators should not be in the same bank of elevators, but somewhere else in the building. This is a viable option in large building with banks of elevator spaced throughout the building.

Cost Impact

The code change proposal will increase the cost of construction .

In the rare situation where multiple elevators are used, the increased cost would be that for the separation between hoistways.

Internal ID: 1235

E33-18

IBC:1009.6.2, (IFC[BE] 1009.6.2)

Proponent: Eirene Knott, BRR Architecture, representing Metropolitan Kansas City Chapter of the ICC (Eirene.Knott@brrarch.com)

2018 International Building Code

Revise as follows:

1009.6.2 Stairway or elevator access. Every required *area of refuge* shall have direct access to a *stairway* complying with Sections 1009.3 and 1023 or an elevator complying with Section 1009.4.

Exception:An interior area of refuge at the level of exit discharge that provides direct access to an exterior exit door.

Reason:

While the code provides clear direction that areas of refuge in a multi story building must have direct access to an elevator or stairway, it is not clear on what qualifies as an interior area of refuge in a single story building. The purpose of this code change is to provide clear direction in the code that an interior area of refuge is permitted in a single story building, or in a multi-story building on the level of exit discharge, without a stairway or elevator which provides immediate access to the exterior of the building.

Cost Impact

The code change proposal will not increase or decrease the cost of construction .

If the code will now allow for an interior area of refuge in a single story building or on the level of exit discharge in a multi-story building, rather than require an exterior area of refuge in either situation, this may actually reduce the cost of construction as the exterior wall would no longer need to have a fire resistance rating.

Internal ID: 115

E34-18

IBC: 1009.6.3 (IFC[BE] 1009.6.3), 1109.2.1.6, 3008.6.4, Chapter 35

Proponent: Dawn Anderson, representing self (gonedawning@yahoo.com); Dan Buuck, representing National Association of Home Builders (dbuuck@nahb.org); David Collins, representing the American Institute of Architects (dcollins@preview-group.com); Marsha Mazz, representing U.S. Access Board (mazz@Access-Board.gov); Dominic Marinelli, representing United Spinal Association (DMarinelli@accessibility-services.com)

2018 International Building Code

Revise as follows:

1009.6.3 Size. Each *area of refuge* shall be sized to accommodate one *wheelchair space* of 30 inches by ~~48~~52 inches (762 mm by ~~1219~~1320 mm) for each 200 occupants or portion thereof, based on the *occupant load* of the *area of refuge* and areas served by the *area of refuge*. Such *wheelchair spaces* shall not reduce the *means of egress* minimum width or required capacity. Access to any of the required *wheelchair spaces* in an *area of refuge* shall not be obstructed by more than one adjoining *wheelchair space*.

Delete without substitution:

~~**1109.2.1.6 Clear floor space.** Where doors swing into a family or assisted use toilet or bathing room, a clear floor space not less than 30 inches by 48 inches (762 mm by 1219 mm) shall be provided, within the room, beyond the area of the door swing.~~

Revise as follows:

3008.6.4 Lobby size. Each occupant evacuation elevator lobby shall have minimum floor area as follows:

1. The occupant evacuation elevator lobby floor area shall accommodate, at 3 square feet (0.28 m²) per person, not less than 25 percent of the *occupant load* of the floor area served by the lobby.
2. The occupant evacuation elevator lobby floor area shall accommodate one *wheelchair space* of 30 inches by ~~48~~52 inches (760 mm by ~~1220~~1320 mm) for each 50 persons, or portion thereof, of the *occupant load* of the floor area served by the lobby.

Exception: The size of lobbies serving multiple banks of elevators shall have the minimum floor area *approved* on an individual basis and shall be consistent with the building's fire safety and evacuation plan.

Update standard(s) as follows:

ICC

International Code Council, Inc.
500 New Jersey Ave NW 6th Floor
Washington DC 20001

US

ICC A117.1-092017:

Accessible and Usable Buildings and Facilities

Reason:

The 2017 ICC A117.1 has revised the clear floor space from 30" by 48" to 30" by 52" for new construction. This new clear floor space size is based on a new study on anthropometrics which includes persons using wheelchairs, motorized wheelchairs and scooters. This proposal includes an increase in size for areas of refuge (including areas of refuge on stairway landings), exterior areas of assisted rescue, and lobbies in occupant evacuation elevators. Section 1109.2.1.6 for family assisted use bathrooms is proposed to be deleted as this requirement is addressed in Section 603 of ICC A117.1.

Cost Impact

The code change proposal will increase the cost of construction .

This is a general statement and may not be true for all cases. Standard details for an area of refuge, occupant evacuation elevator lobby or bus shelter may need to be modified to meet these new requirements, unless they have more floor space than required for the current (smaller) wheelchair spaces. With nearly unlimited possibilities of design options, the exact cost of this change are very difficult to calculate.

Analysis: The 2009 edition of the ICC A117.1 standard is referenced in Chapter 35.

Internal ID: 535

E35-18

IBC: 1009.8.1, (IFC[BE] 1009.8.1)

Proponent: Michael Tomaselli, Anne Arundel County, representing Anne Arundel County (iptoma88@aacounty.org)

2018 International Building Code

Revise as follows:

1009.8.1 System requirements. The two-way communication system shall be designed and installed as an area of rescue assistance emergency communication system in accordance with NFPA 72. Two-way communication systems shall provide communication between each required location and the *fire command center* or a central control point location *approved* by the fire department. Where the central control point is not a *constantly attended location*, a two-way communication system shall have a timed automatic telephone dial-out capability to a monitoring location or 9-1-1. The two-way communication system shall include both audible and visible signals.

Reason:

The IBC (2015 Ed.) - Paragraph 1009.8 requires that a two-way communication be installed at the landing serving each elevator or bank of elevators on an accessible floor that is one or more stories above or below the level of exit discharge. This system is vital for the accessible occupants of a building to communicate their need to be rescued in an emergency situation to the appropriate personnel. Currently, as the IBC states this system is not required to be monitored for integrity or maintain a level of fire resistance. There is no way to ensure that this system is operational if, and when, it is needed unless the system is used at a non-required point in time and found to be in nonworking condition. Also, without a level of fire resistive protection provided the cabling used to maintain working operation is susceptible to fire damage on a given floor.

By requiring this system be designed and installed as an area of rescue assistance emergency communication system in accordance with the 2016 Edition of NFPA 72 the system's pathways will be monitored for integrity and the necessary level of fire protection would be required accordingly. With an open fault on the pathway this system would now be provided either a redundant path or, the trouble would be annunciated at the fire alarm control unit. The system would also be provided with a two-hour fire-rated method of protection where the building it was installed within consisted of two-hour fire-rated construction. Both of these features work to ensure the system is operational when needed. It is not only important to provide a two-communication system for the accessible occupants within a building but it is equally as crucial to ensure that this system provide the service it is was intended for during an emergency event.

Bibliography:

[International Building Code] [2015 Edition] [International Code Council] [2014] [259-260]
[<https://codes.iccsafe.org/public/document/toc/542/>]

[National Fire Alarm and Signaling Code] [NFPA 72, 2016 Edition] [National Fire Protection Association] [2015]
[<http://www.nfpa.org/codes-and-standards/all-codes-and-standards/list-of-codes-and-standards/detail?code=72>]

Cost Impact

The code change proposal will increase the cost of construction .

This code change will increase the cost of construction in buildings with accessible elevators on floors one or more stories above or below the level of exit discharge. In buildings with two-hour fire-rated construction the wiring for the two-way communication system will be required to possess a two-hour fire-rated method of protection; whether it be the cabling itself, a two-hour fire-rated enclosure, two-hour fire-rated cabling system, or an approved alternative. Regardless of the building construction this system will also be required to be monitored for integrity. This monitoring could consist of a redundant pathway, which is additional wiring, or would be required to have any open fault annunciated at the fire alarm control unit as a trouble condition.

Internal ID: 82

E36-18

IBC: 1009.8.1, (IFC[BE] 1009.8.1)

Proponent: Ronald Clements Jr, representing Chesterfield County Building Inspection Department (clementsro@chesterfield.gov)

2018 International Building Code

Revise as follows:

1009.8.1 System requirements. Two-way communication systems shall provide communication between each required location and the *fire command center* or a central control point location *approved* by the fire department. Where the central control point is not a *constantly attended location*, ~~a~~the two-way communication system shall have a timed automatic telephone dial-out capability ~~to a monitoring location that provides two way communication with an approved supervising station~~ or 9-1-1. The two-way communication system shall include both audible and visible signals.

Reason:

There are varied interpretations about what "shall have timed automatic telephone dial-out capability to a monitoring location or 911" means. This text was added by the Egress committee as a modification to code change E37-07/08 to "provide clearer direction on how the phone system was expected to perform". Prior code editions required "controlled access to a public telephone system." Some are interpreting the current text to simply require a one-way signal be sent "to a monitoring service or 911" with no two way communication off-site. The intent was to provide two way communication either to the central control point; or, off-site via a telephone if no one was available at the central control point. The revise text clarifies the intent. The other issue addressed is what is a "monitoring location"? "Monitoring location" is not defined so what is required to approve a monitoring location? All of the other code provisions that address monitoring refer to "approved supervising station". "Supervising station" is defined in IBC chapter 2 and is the alternative to a "constantly attended location" in other code provisions that require monitoring. This code change provides that consistent and IBC defined terminology.

Cost Impact

The code change proposal will increase the cost of construction .

Whether or not this code change increases the cost of construction depends on the local interpretation of the current text. If the local interpretation is that the current text does not require two-way communication off-site then this code change will increase the cost of construction. If the interpretation of current text is that two-way communication must be maintained off-site then this will not increase the cost of construction.

Internal ID: 683

E37-18

IBC: SECTION 1010, (IFC[BE] 1010)

Proponent: Ed Kullik, Chair, representing ICC Building Code Action Committee (bcac@iccsafe.org)

2018 International Building Code

Revise as follows:

SECTION 1010 DOORS, GATES AND TURNSTILES

1010.1 Doors. ~~Means—Doors in the means of egress shall comply with the requirements of Sections 1010.1.1 through 1010.1.3.4. Exterior exit doors shall meet—also comply with the requirements of this section. Doors serving a Section 1022.2. Gates in the means of egress shall comply with the requirements of Section 1010.4 through 1010.4.1. Turnstiles in the means of egress system shall meet—comply with the requirements of this section and Section 1022.2. Doors Section 1010.5 through 1010.5.4.~~

Doors, gates and turnstiles provided for egress purposes in numbers greater than required by this code shall ~~meet~~ comply with the requirements of this section.

Doors in the Means—means of egress doors shall be readily distinguishable from the adjacent construction and finishes such that the doors are easily recognizable as doors. Mirrors or similar reflecting materials shall not be used on *means of egress* doors. *Means of egress* doors shall not be concealed by curtains, drapes, decorations or similar materials.

1010.1.1 Size of doors. (No change to text)

1010.1.1.1 Projections into clear width. (No change to text)

1010.1.2 Door swing. (No change to text)

1010.1.2.1 Direction of swing. (No change to text)

1010.1.3 Door opening force. (No change to text)

1010.1.3.1 Location of applied forces. (No change to text)

~~1010.1.5~~**1010.1.4 Floor elevation.** (No change to text)

~~1010.1.6~~**1010.1.5 Landings at doors.** (No change to text)

~~1010.1.7~~**1010.1.6 Thresholds.** (No change to text)

~~1010.1.8~~**1010.1.7 Door arrangement.** (No change to text)

~~1010.1.9~~**1010.2 Door operations.** (No change to text)

~~1010.1.9.6~~**1010.2.1 Unlatching.** (No change to text)

~~1010.1.9.1~~**1010.2.2 Hardware.** (No change to text)

~~1010.1.9.2~~**1010.2.3 Hardware height.** (No change to text)

~~1010.1.9.4~~**1010.2.4 Locks and latches.** (No change to text)

~~1010.1.9.5~~**1010.2.5 Bolt locks.** (No change to text)

~~1010.1.9.6.1~~**1010.2.6 Closet doors.** (No change to text)

~~1010.1.9.12~~**1010.2.7 Stairway doors.** (No change to text)

~~1010.1.4.4~~ **1010.2.8 Locking arrangements in educational occupancies.** In Group E and Group B educational occupancies, egress doors from classrooms, offices and other occupied rooms shall be permitted to be provided with locking arrangements designed to keep intruders from entering the room where all of the following conditions are met:

1. The door shall be capable of being unlocked from outside the room with a key or other *approved* means.
 2. The door shall be openable from within the room in accordance with Section 1010.1.9.
 - 3.
- Modifications shall not be made to listed *panic hardware*, fire door hardware or door closers.

~~1010.1.4.4.1~~**1010.2.8.1 Remote operation of locks.** (No change to text)

~~1010.1.10~~**1010.2.9 Panic and fire exit hardware.** (No change to text)

~~1010.1.10.1~~**1010.2.9.1 Installation.** (No change to text)

~~1010.1.10.2~~**1010.2.9.2 Balanced doors.** (No change to text)

~~1010.1.9.3~~**1010.2.10 Monitored or recorded egress.** (No change to text)

~~1010.1.9.10~~**1010.2.11 Door hardware release of electrically locked egress doors.** (No change to text)

~~1010.1.9.9~~**1010.2.12 Sensor release of electrically locked egress doors.** (No change to text)

~~1010.1.9.8~~**1010.2.13 Delayed egress.** (No change to text)

~~1010.1.9.8.1~~**1010.2.13.1 Delayed egress locking system.** (No change to text)

~~1010.1.9.7~~**1010.2.14 Controlled egress doors in Groups I-1 and I-2.** (No change to text)

~~1010.1.9.11~~**1010.2.15 Locking arrangements in buildings within correctional facilities.** (No change to text)

~~1010.1.4~~**1010.3 Special doors.** (No change to text)

~~1010.1.4.1~~**1010.3.1 Revolving doors.** (No change to text)

**TABLE ~~1010.1.4.1~~1010.3.1(1)
MAXIMUM DOOR SPEED MANUAL REVOLVING DOORS**

REVOLVING DOOR MAXIMUM NOMINAL DIAMETER (FT-IN)	MAXIMUM ALLOWABLE REVOLVING DOOR SPEED (RPM)
6-0	12
7-0	11
8-0	10
9-0	9
10-0	8

For SI: 1 inch = 25.4 mm, 1 foot = 304.8 mm.

**TABLE ~~1010.1.4.1~~1010.3.1(2)
MAXIMUM DOOR SPEED AUTOMATIC OR POWER-OPERATED REVOLVING DOORS**

REVOLVING DOOR MAXIMUM NOMINAL DIAMETER (FT -IN)	MAXIMUM ALLOWABLE REVOLVING DOOR SPEED (RPM)
8-0	7.2
9-0	6.4
10-0	5.7
11-0	5.2
12-0	4.8
12-6	4.6
14-0	4.1
16-0	3.6
17-0	3.4

18-0	3.2
20-0	2.9
24-0	2.4

For SI: 1 inch = 25.4 mm, 1 foot = 304.8 mm.

~~1010.1.4.1.1~~**1010.3.1.1 Egress component.** (No change to text)

~~1010.1.4.1.2~~**1010.3.1.2 Other than egress component.** (No change to text)

~~1010.1.4.2~~**1010.3.2 Power-operated doors.** (No change to text)

~~1010.1.4.3~~**1010.3.3 Special purpose horizontal sliding, accordion or folding doors.** (No change to text)

~~1010.1.4.5~~**1010.3.4 Security grilles.** (No change to text)

~~1010.2~~**1010.4 Gates.** (No change to text)

~~1010.2.1~~**1010.4.1 Stadiums.** (No change to text)

~~1010.3~~**1010.5 Turnstiles and similar devices.** (No change to text)

~~1010.3.1~~**1010.5.1 Capacity.** (No change to text)

~~1010.3.1.1~~**1010.5.1.1 Clear width.** (No change to text)

~~1010.3.2~~**1010.5.2 Security access turnstiles.** (No change to text)

~~1010.3.3~~**1010.5.3 High turnstile.** (No change to text)

~~1010.3.4~~**1010.5.4 Additional door.** (No change to text)

Reason:

This is a reorganization of the door section to group like items together. There is not intended to be any technical changes.

Start in 1010.1 by recognizing that this section covers doors, gates and turnstiles. Clean up the reference to Section 1022.2 to be more specific.

List all door requirements – 1010.1.1 through 1010.1.7

Separate out door hardware requirements from the doors themselves – new section 1010.2

Relocate unlatching as generic requirement to beginning of hardware section – relocate to 1010.2.1

Group hardware requirements – height, monitoring, locks, bolt locks, sensor release, door hardware release

Group requirements for special safety concerns – closets, stairways, locking in schools, panic hardware. (The school criteria is currently under specials doors – this is definitely a locking criteria. With the new location, Item 2 is not needed).

Moved all the electrical locking arrangements (other than I-3 correctional facilities) to be next to each other, and ordered from most common to least common. Put the monitored or recorded egress section prior to these 4 electrical locking sections because monitored or recorded egress would almost exclusively be used with one of the electrical locking arrangements.

Group Special doors: revolving, power operated, horizontal sliding security grills – new section 1010.3

Renumber gates and turnstiles.

This proposal is submitted by the ICC Building Code Action Committee (BCAC). BCAC was established by the ICC Board of Directors in July 2011 to pursue opportunities to improve and enhance assigned International Codes or portions thereof. In 2017 the BCAC has held 3 open meetings. In addition, there were numerous Working Group meetings and conference calls for the current code development cycle, which included members of the committee as well as any interested party to discuss and debate the proposed changes. Related documentation and reports are posted on the

BCAC website at: <https://www.iccsafe.org/codes-tech-support/codes/codedevelopment-process/building-code-action-committee-bcac>.

Cost Impact

The code change proposal will not increase or decrease the cost of construction .

This proposal reorganizes Section 1010 to provide clarity for the code user for the requirements for doors and door hardware. There are no technical changes to Section 1010.

Internal ID: 451

E38-18

IBC: 1010.1, 1020.1 (New), 1024.1, 1026.1, 1027.1, 1028.4, 1028.4.1, 1028.4.2, 1029(New), (IFC[BE] 1010.1, 1020.1 (New), 1024.1, 1026.1, 1027.1, 1028.4, 1028.4.1, 1028.4.2, 1029(New))

Proponent: Gregory Keith, representing The Boeing Company (grkeith@mac.com)

2018 International Building Code

Revise as follows:

1010.1 Doors General. ~~Means of egress doors shall meet the requirements of this section.~~ Doors, gates and turnstiles serving a *means of egress* system shall meet the applicable requirements of this section and Section 1022.2. Doors provided for egress purposes in numbers greater than required by this code shall meet the requirements of this section.

Means of egress doors shall be readily distinguishable from the adjacent construction and finishes such that the doors are easily recognizable as doors. Mirrors or similar reflecting materials shall not be used on *means of egress* doors. *Means of egress* doors shall not be concealed by curtains, drapes, decorations or similar materials.

Add new text as follows:

1020.1 General. Corridors serving as an exit access component in a means of egress system shall comply with the requirements of this section.

Revise as follows:

1024.1 Exit passageways General. Exit passageways serving as an exit component in a *means of egress* system shall comply with the requirements of this section. An *exit passageway* shall not be used for any purpose other than as a *means of egress* and a *circulation path*.

1026.1 Horizontal exits General. Horizontal *exits* serving as an exit in a *means of egress* system shall comply with the requirements of this section. A *horizontal exit* shall not serve as the only exit from a portion of a building, and where two or more *exits* are required, not more than one-half of the total number of *exits* or total exit minimum width or required capacity shall be horizontal *exits*.

Exceptions:

1. Horizontal *exits* are permitted to comprise two-thirds of the required *exits* from any building or floor area for occupancies in Group I-2.
2. Horizontal *exits* are permitted to comprise 100 percent of the *exits* required for occupancies in Group I-3. Not less than 6 square feet (0.6 m²) of *accessible* space per occupant shall be provided on each side of the *horizontal exit* for the total number of people in adjoining compartments.

1027.1 Exterior exit stairways and ramps General. Exterior *exit stairways* and *ramps* serving as an element of exit component in a ~~required~~ *means of egress system* shall comply with the requirements of this section.

Add new text as follows:

1029 EGRESS COURTS

Revise as follows:

~~1028.4~~ **1029.1 Egress courts General.** ~~Egress courts serving as a portion of the~~ *an exit discharge component* in the *means of egress* system shall comply with the requirements of Sections 1028.4.1 and 1028.4.2 in this section.

~~1028.4.1~~ **1029.2 Width or capacity.** The required capacity of *egress courts* shall be determined as specified in Section 1005.1, but the minimum width shall be not less than 44 inches (1118 mm), except as specified herein. *Egress courts* serving Group R-3 and U occupancies shall be not less than 36 inches (914 mm) in width. The required capacity and width of *egress courts* shall be unobstructed to a height of 7 feet (2134 mm). The width of the *egress court* shall be not less than the required capacity.

Exception: Encroachments complying with Section 1005.7.

1028.4-21029.3 Construction and openings. Where an *egress court* serving a building or portion thereof is less than 10 feet (3048 mm) in width, the *egress court* walls shall have not less than 1-hour *fire-resistance-rated* construction for a distance of 10 feet (3048 mm) above the floor of the *egress court*. Openings within such walls shall be protected by opening protectives having a fire protection rating of not less than $\frac{3}{4}$ hour.

Exceptions:

1. *Egress courts* serving an *occupant load* of less than 10.
2. *Egress courts* serving Group R-3.

Reason:

This is a series of editorial revisions intended to formalize the charging language of several sections within Chapter 10. The International Building Code is a so-called model code. Once adopted by a given political subdivision it becomes law. Having proper enabling or charging provisions for various technical requirements is legally necessary.

Presently, Section 1020 for corridors contains no charging language. A general section has been created using the same format as is currently used in Section 1018 for aisles and Section 1019 for exit access stairways and ramps.

Section 1010.1 has been improved by adding the "General" section title to be consistent with other means of egress component sections. Additionally, the first and second sentences of Section 1010.1 are redundant. The first sentence has been deleted. The second sentence now clarifies that the section is applicable to gates and turnstiles consistent with the Section 1010 heading.

The titles of Sections 1024.1, 1026.1 and 1027.1 have been changed to "General" to be consistent with other means of egress component sections.

Lastly, egress courts are a means of egress component. In the Chapter 10 format, individual means of egress components have their own section. Currently, egress court provisions are located in Section 1028.4 within the exit discharge section. This proposal simply relocates the egress court technical provisions to a new Section 1029 so as to be consistent with other Chapter 10 provisions.

This proposal establishes the proper legal charging language for lacking sections. In doing so, it provides consistency within the various Chapter 10 means of egress component sections. Some practitioners are given to assigning an importance factor between different terms and formats. Approval of this proposal will clarify these important means of egress provisions.

Cost Impact

The code change proposal will not increase or decrease the cost of construction .

This proposal is essentially editorial.

Internal ID: 1552

E39-18

IBC: 1010.1.1, (IFC[BE] 1010.1.1)

Proponent: John Woestman, Kellen Co., representing Builders Hardware Manufacturers Association (BHMA)
(jwoestman@kellencompany.com)

2018 International Building Code

Revise as follows:

1010.1.1 Size of doors. The required capacity of each door opening shall be sufficient for the *occupant load* thereof and shall provide a minimum clear opening width of 32 inches (813 mm). The clear opening width of doorways with swinging doors shall be measured between the face of the door and the stop, with the door open 90 degrees (1.57 rad). Where this section requires a minimum clear opening width of 32 inches (813 mm) and a door opening includes two door leaves without a mullion, one leaf shall provide a minimum clear opening width of 32 inches (813 mm). In Group I-2, doors serving as *means of egress* doors where used for the movement of beds shall provide a minimum clear opening width of 41¹/₂ inches (1054 mm). The ~~maximum width of a swinging door leaf shall be 48 inches (1219 mm) nominal.~~ The minimum clear opening height of doors shall be not less than 80 inches (2032 mm).

Exceptions:

1. In Group R-2 and R-3 *dwelling and sleeping units* that are not required to be an Accessible unit, Type A unit or Type B unit, the minimum ~~and maximum~~ width shall not apply to door openings that are not part of the required *means of egress*.
2. In Group I-3, door openings to resident *sleeping units* that are not required to be an *Accessible unit* shall have a minimum clear opening width of 28 inches (711 mm).
3. Door openings to storage closets less than 10 square feet (0.93 m²) in area shall not be limited by the minimum clear opening width.
4. The maximum width of door leaves in revolving doors that comply with Section 1010.1.4.1 shall not be limited.
5. The maximum width of door leaves in *power-operated doors* that comply with Section 1010.1.4.2 shall not be limited.
6. Door openings within a *dwelling unit* or *sleeping unit* shall have a minimum clear opening height of 78 inches (1981 mm).
7. In *dwelling and sleeping units* that are not required to be Accessible, Type A or Type B units, exterior door openings other than the required *exit* door shall have a minimum clear opening height of 76 inches (1930 mm).
8. In Groups I-1, R-2, R-3 and R-4, in *dwelling and sleeping units* that are not required to be Accessible, Type A or Type B units, the minimum clear opening widths shall not apply to interior egress doors.
9. Door openings required to be *accessible* within *Type B units* intended for user passage shall have a minimum clear opening width of 31.75 inches (806 mm).
10. Doors to walk-in freezers and coolers less than 1,000 square feet (93 m²) in area shall have a maximum width of 60 inches (1524 mm) nominal.
11. The minimum clear opening width shall not apply to doors for nonaccessible shower or sauna compartments.
12. The minimum clear opening width shall not apply to the doors for nonaccessible toilet stalls.

Reason:

This proposal deletes the 48" maximum width requirements for swinging doors.

From the IBC Commentary: The maximum width for a means of egress door leaf in a swinging door is 48 inches (1219 mm) because larger doors are difficult to handle and are of sizes that typically are not fire tested.

We somewhat agree with this statement in the IBC Commentary. However, it is the width plus the height and the construction of the door (i.e. weight) which results in a door which may be difficult to open and / or close. Our perspective is the performance requirements in IBC Section 1010.1.3 Door Opening Force and the Chapter 11 Accessibility requirements effectively result in the design and installation of appropriately-sized doors. Regarding fire tested doors (i.e. fire-rated doors) - the solution is simple - install fire-rated doors which meet the existing door

opening force requirements of the IBC.

The revision in the 1st exception correlates with the proposed deleted text in the charging paragraph.

The revision in the 4th exception clarifies the exception.

From a different perspective, NFPA 101 has not had a requirement for maximum swinging door leaf width since the 1997 edition, stating there is insufficient reason to limit the maximum width of a door leaf provided the door is maintained in good working order. In addition, there is a trend in health-care occupancies for wider doorways to accommodate patient and equipment movement needs.

Cost Impact

The code change proposal will not increase or decrease the cost of construction .

We see no cost implications for the vast majority of buildings. However, this proposal may allow the use of a single door - that meets all IBC operational force requirements - where today the 48" width limit results in two doors in an opening. In these rare situations, the cost of construction may be reduced.

Internal ID: 2299

E40-18

IBC: 1010.1.1 (IFC[BE] 1010.1.1)

Proponent: Eirene Knott, BRR Architecture, representing Metropolitan Kansas City Chapter of the ICC (Eirene.Knott@brrarch.com)

2018 International Building Code

Revise as follows:

1010.1.1 Size of doors. The required capacity of each door opening shall be sufficient for the *occupant load* thereof and shall provide a minimum clear opening width of 32 inches (813 mm). The clear opening width of doorways with swinging doors shall be measured between the face of the door and the stop, with the door open 90 degrees (1.57 rad). Where this section requires a minimum clear opening width of 32 inches (813 mm) and a door opening includes two door leaves without a mullion, one leaf shall provide a minimum clear opening width of 32 inches (813 mm). In Group I-2, doors serving as *means of egress* doors where used for the movement of beds shall provide a minimum clear opening width of 41¹/₂ inches (1054 mm). The maximum width of a swinging door leaf shall be 48 inches (1219 mm) nominal. The minimum clear opening height of doors shall be not less than 80 inches (2032 mm).

Exceptions:

1. In Group R-2 and R-3 *dwelling and sleeping units* that are not required to be an Accessible unit, Type A unit or Type B unit, the minimum and maximum width shall not apply to door openings that are not part of the required *means of egress*.
2. In Group I-3, door openings to resident *sleeping units* that are not required to be an Accessible unit shall have a minimum clear opening width of 28 inches (711 mm).
3. Door openings to storage closets less than 10 square feet (0.93 m²) in area shall not be limited by the minimum clear opening width.
4. The width of door leaves in revolving doors that comply with Section 1010.1.4.1 shall not be limited.
5. The maximum width of door leaves in *power-operated doors* that comply with Section 1010.1.4.2 shall not be limited.
6. Door openings within a *dwelling unit* or *sleeping unit* shall have a minimum clear opening height of 78 inches (1981 mm).
7. In *dwelling and sleeping units* that are not required to be Accessible, Type A or Type B units, exterior door openings other than the required *exit* door shall have a minimum clear opening height of 76 inches (1930 mm).
8. In Groups I-1, R-2, R-3 and R-4, in *dwelling and sleeping units* that are not required to be Accessible, Type A or Type B units, the minimum clear opening widths shall not apply to interior egress doors.
9. Door openings required to be *accessible* within *Type B units* intended for user passage shall have a minimum clear opening width of 31.75 inches (806 mm).
10. Doors to walk-in freezers and coolers less than 1,000 square feet (93 m²) in area shall have a maximum width of 60 inches (1524 mm) nominal.
11. The minimum clear opening width shall not apply to doors for nonaccessible shower or sauna compartments.
12. The minimum clear opening width shall not apply to the doors for nonaccessible toilet stalls.
13. The minimum clear opening width shall not apply to the doors for nonaccessible dressing, fitting or changing rooms.

Reason:

In the 2015/2016/2017 code development cycle, two changes, E47 and F243, were approved which added language in this section to allow for doors serving non-accessible saunas, shower compartments and toilet stalls to be less than 32 inches. The doors serving dressing/fitting/changing rooms serve the same purpose as these doors, which is to provide for access into and out of the room. If accessible dressing/fitting/changing rooms are provided per IBC 1109.12.1, the remaining dressing/fitting/changing rooms would meet the same requirements as those non-accessible sauna, shower compartment and toilet stall doors.

Cost Impact

The code change proposal will decrease the cost of construction .

This proposal may decrease the cost of construction if a smaller door is permitted as less materials will be required.

Internal ID: 114

E41-18

IBC: 1010.1.1.1, (IFC[BE] 1010.1.1.1)

Proponent: John Woestman, representing Builders Hardware Manufacturers Association (BHMA)
(jwoestman@kellencompany.com)

2018 International Building Code

Revise as follows:

1010.1.1.1 Projections into clear ~~width-opening~~. There shall not be projections into the required clear opening width lower than 34 inches (864 mm) above the floor or ground. Projections into the clear opening width between 34 inches (864 mm) and 80 inches (2032 mm) above the floor or ground shall not exceed 4 inches (102 mm).

Exception: Door closers, overhead door stops, power door operators, and electromagnetic door ~~stops-locks~~ shall be permitted to be 78 inches (1980 mm) minimum above the floor.

Reason:

Clarifying the "door stops" in the exception are overhead door stops. Also, proposing to include in the exception door operational hardware which is commonly installed and may project into the opening at the top of the doorway. And, it seems appropriate to revise the title of Section 1010.1.1.1.

Below are several pictures which illustrate these hardware items.

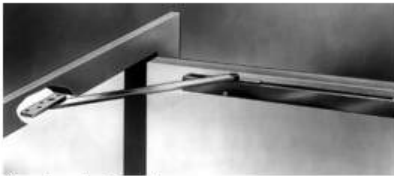

Overhead door stop.
Photo courtesy ASSA ABLOY



Power door operator.
Photo courtesy domakaha



Power door operators (left doors), door closer (right door).
Photo courtesy Hager Companies



Electromagnetic door lock (top-left corner of doorway) and door closer.
Photo courtesy Allegion

Cost Impact

The code change proposal will not increase or decrease the cost of construction .

No cost implications identified with this proposal. This allows additional door operation with no increase in code requirements.

Internal ID: 2305

E42-18

IBC: 1010.1.2, 1010.1.2.1, (IFC[BE] 1010.1.2, 1010.1.2.1)

Proponent: John Woestman, Kellen Co., representing Builders Hardware Manufacturers Association (BHMA)
(jwoestman@kellencompany.com)

2018 International Building Code

Revise as follows:

1010.1.2 ~~Door swing.~~Egress door types. Egress doors shall be of the ~~pivoted or side-hinged swinging type door, pivoted door, or balanced door types.~~

Exceptions:

1. Private garages, office areas, factory and storage areas with an *occupant load* of 10 or less.
2. Group I-3 occupancies used as a place of detention.
3. Critical or intensive care patient rooms within suites of health care facilities.
4. Doors within or serving a single *dwelling unit* in Groups R-2 and R-3.
5. In other than Group H occupancies, revolving doors complying with Section 1010.1.4.1.
6. In other than Group H occupancies, special purpose horizontal sliding, accordion or folding door assemblies complying with Section 1010.1.4.3.
7. Power-operated doors in accordance with Section 1010.1.4.2.
8. Doors serving a bathroom within an individual *sleeping unit* in Group R-1.
9. In other than Group H occupancies, manually operated horizontal sliding doors are permitted in a *means of egress* from spaces with an *occupant load* of 10 or less.

1010.1.2.1 Direction of swing. ~~Pivot or side~~Side-hinged swinging doors, pivoted doors, and balanced doors shall swing in the direction of egress travel where serving a room or area containing an *occupant load* of 50 or more persons or a Group H occupancy.

Reason:

Updating 1010.1.2 to add balanced doors to the other common types of swinging doors allowed and used in the means of egress. Also revising the title of the section. Requirements for panic hardware on balanced doors is addressed in 1010.1.10.2 (text pasted below) - thus it can be assumed the intent of the code is that balanced doors are OK for doors in the means of egress.

Also, revising 1010.1.2.1 for consistency.

2018 IBC 1010.1.10.2 Balanced doors. If balanced doors are used and panic hardware is required, the panic hardware shall be the push-pad type and the pad shall not extend more than one-half the width of the door measured from the latch side

Several pictures below illustrate these types of doors.



Side-hinged door.
Photo courtesy Allegion



Pivoted door
Photo courtesy Allegion



Balanced door.
Photo courtesy C. R. Laurence

Cost Impact

The code change proposal will not increase or decrease the cost of construction .

Proposal updates code technically to more closely match types of doors being installed in the means of egress.

Internal ID: 2315

E43-18

IBC: 1010.1.2, 1010.1.4.6(New), (IFC[BE] 1010.1.2, 1010.1.4.6(New))

Proponent: Joseph Hetzel, Thomas Associates, Inc., representing Door & Access Systems Manufacturers Association (jhetzel@thomasamc.com)

2018 International Building Code

Revise as follows:

1010.1.2 Door swing. Egress doors shall be of the pivoted or side-hinged swinging type.

Exceptions:

1. Private garages, office areas, factory and storage areas with an *occupant load* of 10 or less.
2. Group I-3 occupancies used as a place of detention.
3. Critical or intensive care patient rooms within suites of health care facilities.
4. Doors within or serving a single *dwelling unit* in Groups R-2 and R-3.
5. In other than Group H occupancies, revolving doors complying with Section 1010.1.4.1.
6. In other than Group H occupancies, special purpose horizontal sliding, accordion or folding door assemblies complying with Section 1010.1.4.3.
7. Power-operated doors in accordance with Section 1010.1.4.2.
8. Doors serving a bathroom within an individual *sleeping unit* in Group R-1.
9. In other than Group H occupancies, manually operated horizontal sliding doors are permitted in a *means of egress* from spaces with an *occupant load* of 10 or less.
10. In other than Groups A, E and H occupancies, high speed doors complying with Section 1010.1.4.6.

Add new text as follows:

1010.1.4.6 High speed doors. High speed doors shall include interior non-rated rolling, folding and sliding powered door assemblies, with a minimum opening speed of 32 inches per second, a minimum closing speed of 24 inches per second, and provide a means to automatically close the door. High speed doors shall comply with one of the following:

1. The door shall be operable by a simple method from either side of the opening without special knowledge or effort. The force required to operate the door shall not exceed 30 pounds (133 N) to set the door in motion and 15 pounds (67 N) to open the door to the minimum required height or width.
2. The door assembly shall have an integrated standby power supply, shall be electrically supervised, shall open to a minimum height of 80 inches (2.03 m) or a minimum width of 32 inches (813 mm) within 10 seconds after activation of the operating device, and shall stay open until full power is resumed.
3. The door panels shall be capable of being broken out manually in the event of power failure by a simple method from either side without special knowledge or effort. The force required to break out the door panels shall not exceed 30 pounds (133 N), and the force required to open the door panels to the minimum height and width shall not exceed 15 pounds (67 N).

Reason:

1. Brings codification to use in locations already occurring. High speed doors are often used in interior locations where such doors are the only means of exiting a space typically used for environmental/climate control, and where pivoted or side-hinged swinging doors cannot be used because of the need for such control. Therefore, provisions are needed in order for egress oriented high speed doors to be found compliant with the IBC other than using the Alternative Methods provisions because of the increasing frequency of use of such doors.
2. Belongs in a standalone code section under "special doors". Because they are non-swinging (neither pivoted nor side-hinged swinging) doors, high speed doors should be included as a new Exception in Section 1010.1.2.
3. Different fire related application calls for standalone provisions. Because they are not fire-rated products, high speed door requirements should be separate from those involving special purpose horizontal sliding, accordion or

folding doors.

4. Group exclusions have code precedence. The exclusion from Groups A, E and H is consistent with the limitation currently applied to using delayed egress locking systems.

5. "High speed door" description has code precedence. The description proposed for the term "high speed door" is similar in description of action to the definition of the term as contained in the International Energy Conservation Code.

6. Requirements have code precedence. Language involving maximum forces, making consideration to avoid special knowledge or effort, integrated standby power supply, and electrically supervised power supply is similar to that used for special purpose horizontal sliding, accordion or folding doors.

7. Each compliance option is an effective standalone option. Although high speed door manufacturers can integrate more than one option into their door designs, each option alone can provide needed egress.

Cost Impact

The code change proposal will not increase or decrease the cost of construction .

The code proposal is based on the premise that a high speed door is the only alternative for the door opening. With respect to other types of doors acceptable in other places as a component of a means of egress, a lower construction cost may be realized by using doors with one option without compromising safety.

Internal ID: 360

E44-18

IBC: 1010.1.3, (IFC[BE] 1010.1.3)

Proponent: John Woestman, Kellen Co., representing Builders Hardware Manufacturers Association (BHMA)
(jwoestman@kellencompany.com)

2018 International Building Code

Delete and substitute as follows:

~~**1010.1.3 Door opening force.** The force for pushing or pulling open interior swinging egress doors, other than fire doors, shall not exceed 5 pounds (22 N). These forces do not apply to the force required to retract latch bolts or disengage other devices that hold the door in a closed position. For other swinging doors, as well as sliding and folding doors, the door latch shall release when subjected to a 15-pound (67 N) force. The door shall be set in motion when subjected to a 30-pound (133 N) force. The door shall swing to a full-open position when subjected to a 15-pound (67 N) force.~~

1010.1.3 Forces to unlatch and open doors. The forces to unlatch and to open doors shall comply with the following:

1. Where door hardware operates by push or pull, the operational force to unlatch the door shall not exceed 15 pounds (66.7N). Where door hardware operates by rotation, the operational force to unlatch the door shall not exceed 28 inch-pounds (315 N-cm).
2. For manual interior swinging egress doors other than doors required to be fire rated, the force for pushing or pulling open the door shall not exceed 5 pounds (22 N).
3. For other swinging, sliding, or folding doors, and doors required to be fire-resistance-rated, the door shall require not more than a 30-pound (133 N) force to be set in motion and shall move to a full-open position when subjected to not more than a 15-pound (67 N) force.

Reason:

Updating and clarifying the maximum forces allowed to unlatch and open doors and correlating requirements with A117.1.

Item 1: The current IBC requirements in 1010.1.3 for maximum unlatching forces could be considered somewhat ambiguous. The proposed requirements in Item 1 are consistent with the requirements in the latest edition of A117.1, Section 404.2.6 and consistent with other ANSI standards for door hardware operational forces.

Items 2 and 3: The revisions in Items 2 and 3 are intended to clarify existing requirements in 1010.1.3.

Item 2 is based on the first sentence of 1010.1.3. Item 3 is based on the last two sentences of 1010.1.3.

Cost Impact

The code change proposal will not increase or decrease the cost of construction .

This proposal clarifies this section of the code, and correlates the code requirements to current accessibility requirements and to current requirements in several ANSI standards for door hardware

Internal ID: 2309

E45-18

IBC: 1010.1.3.2 (New), (IFC[BE] 1010.1.3.2 (New))

Proponent: John Williams, Chair, representing Healthcare Committee (AHC@iccsafe.org); Ed Kullik, Chair, representing ICC Building Code Action Committee (bcac@iccsafe.org)

2018 International Building Code

Add new text as follows:

1010.1.3.2 Manual horizontal sliding doors. Where a manual horizontal sliding door is required to latch, the latch or other mechanism shall prevent the door from rebounding into a partially open position when the door is closed.

Reason:

In the event that horizontal doors are installed under these conditions the proposed language clarifies performance when a door is forcefully closed.

For Group I-2 and ambulatory care facilities this clarification of language is required in order to conform to Federal Standards and Centers for Medicaid and Medicare Services enforcement rules (K224).

This proposal is submitted by the ICC Committee on Healthcare (CHC) and the ICC Building Code Action Committee (BCAC). The CHC was established by the ICC Board to evaluate and assess contemporary code issues relating to healthcare facilities. This is a joint effort between ICC and the American Society for Healthcare Engineering (ASHE), a subsidiary of the American Hospital Association, to eliminate duplication and conflicts in healthcare regulation. In 2017 the CHC held 2 open meetings and numerous conference calls, which included members of the committees as well as any interested parties, to discuss and debate the proposed changes. Information on the CHC, including: meeting agendas; minutes; reports; resource documents; presentations; and all other materials developed in conjunction with the CHC effort can be downloaded from the CHC website at: <https://www.iccsafe.org/codes-tech-support/cs/icc-committee-on-healthcare/>.

BCAC was established by the ICC Board of Directors in July 2011 to pursue opportunities to improve and enhance assigned International Codes or portions thereof. In 2017 the BCAC has held 3 open meetings. In addition, there were numerous Working Group meetings and conference calls for the current code development cycle, which included members of the committee as well as any interested party to discuss and debate the proposed changes. Related documentation and reports are posted on the BCAC website at: <https://www.iccsafe.org/codes-tech-support/codes/codedevelopment-process/building-code-action-committee-bcac>.

Cost Impact

The code change proposal will increase the cost of construction .

If a horizontal sliding door is chosen where a door is required to latch, this requirement would add some performance requirements to stop the door from rebounding.

Internal ID: 594

E46-18

IBC: 1010.1.4.1, (IFC[BE] 1010.1.4.1)

Proponent: John Woestman, Kellen Co., representing Builders Hardware Manufacturers Association (BHMA)
(jwoestman@kellencompany.com)

2018 International Building Code

Revise as follows:

1010.1.4.1 Revolving doors. Revolving doors shall comply with the following:

1. Revolving doors shall comply with BHMA A156.27 and shall be installed in accordance with the manufacturer's instructions.
2. Each revolving door shall be capable of *breakout* in accordance with BHMA A156.27 and shall provide an aggregate width of not less than 36 inches (914 mm).
3. A revolving door shall not be located within 10 feet (3048 mm) of the foot or top of *stairways* or escalators. A dispersal area shall be provided between the *stairways* or escalators and the revolving doors.
4. The revolutions per minute (rpm) for a revolving door shall not exceed the maximum rpm as specified in BHMA A156.27. Manual revolving doors shall comply with Table 1010.1.4.1(1). Automatic or *power-operated* revolving doors shall comply with Table 1010.1.4.1(2).
5. An emergency stop switch shall be provided near each entry point of power or automatic operated revolving doors within 48 inches (1220 mm) of the door and between ~~24-34 inches (610-864 mm)~~ and 48 inches (1220 mm) above the floor. The activation area of the emergency stop switch button shall be not less than 1 inch (25 mm) in diameter and shall be red.
6. Each revolving door shall have a side-hinged swinging door that complies with Section 1010.1 in the same wall and within 10 feet (3048 mm) of the revolving door.
7. Revolving doors shall not be part of an *accessible route* required by Section 1009 and Chapter 11.

Reason:

Revise vertical range requirements for mounting of the emergency stop switch to be consistent with accessibility requirements for reach ranges and to be consistent with the latest edition of ANSI/BHMA A156.27.

Cost Impact

The code change proposal will not increase or decrease the cost of construction .

Proposal is consistent with current accessibility requirements for reach ranges, and consistent with the latest edition of ANSI/BHMA A156.27 (which revolving doors are required to comply with).

Internal ID: 2312

E47-18

IBC: 1010.1.4.3, (IFC[BE] 1010.1.4.3)

Proponent: William Koffel, representing WonDoor (wkoffel@koffel.com)

2018 International Building Code

1010.1.4.3 Special purpose horizontal sliding, accordion or folding doors. In other than Group H occupancies, special purpose horizontal sliding, accordion or folding door assemblies permitted to be a component of a *means of egress* in accordance with Exception 6 to Section 1010.1.2 shall comply with all of the following criteria:

1. The doors shall be power operated and shall be capable of being operated manually in the event of power failure.
2. The doors shall be openable by a simple method ~~from both sides~~ without special knowledge or effort ~~or effort from the egress side or sides.~~
3. The force required to operate the door shall not exceed 30 pounds (133 N) to set the door in motion and 15 pounds (67 N) to close the door or open it to the minimum required width.
4. The door shall be openable with a force not to exceed 15 pounds (67 N) when a force of 250 pounds (1100 N) is applied perpendicular to the door adjacent to the operating device.
5. The door assembly shall comply with the applicable *fire protection rating* and, where rated, shall be self-closing or automatic closing by smoke detection in accordance with Section 716.2.6.6, shall be installed in accordance with NFPA 80 and shall comply with Section 716.
6. The door assembly shall have an integrated standby power supply.
7. The door assembly power supply shall be electrically supervised.
8. The door shall open to the minimum required width within 10 seconds after activation of the operating device.

Reason:

In many instances these doors are used in locations that require egress from both sides. However, there may be applications in which the direction of exit access travel is from only one side. Furthermore, the doors are now being used in security applications and as such, may not be manually operable from one side. This application should be permitted provided the egress requirements for the "secure" area can be met without requiring an occupant to pass through the door.

For example, one might want to secure the lobby area of an office building with a special purpose horizontal sliding, accordion style door to prevent access to other parts of the building by unauthorized personnel. As long as the means of egress requirements can be met for the lobby area, the door would not need to be manually operable from the lobby side.

Cost Impact

The code change proposal will not increase or decrease the cost of construction .

The code change proposal offers a design alternative to meet security needs of a particular building. It is one way to meet those needs and as such, the cost of construction is not impacted by the change.

Internal ID: 1345

E48-18

IBC: 1010.1.4.4, 1010.1.4.4.1, (IFC[BE] 1010.1.4.4, 1010.1.4.4.1); IFC: 1031.2.2

Proponent: Ed Kullik, Chair, representing ICC Building Code Action Committee (bcac@iccsafe.org); Michael O'Brian, Chair, representing FCAC (fcac@iccsafe.org)

2018 International Building Code

Revise as follows:

1010.1.4.4 Locking arrangements in educational occupancies. In Group E ~~and occupancies~~, Group B educational occupancies and Group I-4 occupancies, egress doors from classrooms, offices and other occupied rooms ~~shall be permitted to be provided with locking arrangements designed to keep intruders from entering the room where shall comply with all of the following conditions are met:~~

1. The door shall be capable of being unlocked from outside the room with a key or other *approved* means.
2. The door shall be openable from within the room in accordance with Section 1010.1.9.
3. Modifications shall not be made to listed *panic hardware*, fire door hardware or door closers.
4. Modifications to fire door assemblies shall be in accordance with NFPA 80.

Remote locking or unlocking of doors from an approved location shall be permitted in addition to the unlocking operation in Item 1.

Delete without substitution:

~~**1010.1.4.4.1 Remote operation of locks.** Remote operation of locks complying with Section 1010.1.4.4 shall be permitted.~~

2018 International Fire Code

Revise as follows:

[BE] 1031.2.2 Locking arrangements in educational occupancies. In Group E occupancies, Group B educational occupancies and Group I-4 occupancies, egress doors ~~from classrooms, offices and other occupied rooms shall be permitted to be provided with locking arrangements designed to keep intruders from entering the room shall comply with Section 1010.1.4.4. where all of the following conditions are met:~~

1. ~~The door shall be capable of being unlocked from outside the room with a key or other approved means.~~
2. ~~The door shall be openable from within the room in accordance with Section 1010.1.9.~~
3. ~~Modifications shall not be made to existing listed panic hardware, fire door hardware or door closers.~~
4. ~~Modifications to fire door assemblies shall be in accordance with NFPA 80.~~

Reason:

During the last code development cycle several proposals were accepted to address various locking arrangements being proposed for educational occupancies. During the Group A and Group B cycles, there were additions made to the various proposals, which results in current code language that is not entirely correlated. This proposal attempts to correlate the codes so requirements are consistent throughout.

IFC includes allowances for Group I-4, which are not listed in the IBC. Lock-down plans for day care facilities are as important as for schools. The further language for Group I-4 "child day care" is not needed to describe the occupancy.

The reason statement for the public comment said that the committee did not want to make these locks mandatory, but by using "shall be permitted", lock-down systems could be provided that did not comply with these requirements. With the proposed language, a school could choose to add locks to keep out intruders, but those locks would have to comply with these important safety features.

Subsection 1010.1.4.4.1 is confusing. The allowance for remote unlocking from the outside could easily be included in

Section 1010.1.4.4. This was not included in IFC.

There will be a correlative change submitted to IEBC as part of Group B proposals since this is an important modification being done by schools across the country.

This proposal is submitted by the ICC Building Code Action Committee (BCAC) and Fire Code Action Committee (FCAC). BCAC was established by the ICC Board of Directors in July 2011 to pursue opportunities to improve and enhance assigned International Codes or portions thereof. In 2017 the BCAC has held 3 open meetings. In addition, there were numerous Working Group meetings and conference calls for the current code development cycle, which included members of the committee as well as any interested party to discuss and debate the proposed changes. Related documentation and reports are posted on the BCAC website at: <https://www.iccsafe.org/codes-tech-support/codes/codedevelopment-process/building-code-action-committee-bcac/>.

The FCAC was established by the ICC Board of Directors to pursue opportunities to improve and enhance assigned International Codes with regard to fire safety and hazardous materials in new and existing buildings and facilities and the protection of life and property in wildland urban interface areas. In 2017 the Fire-CAC has held 3 open meetings. In addition, there were numerous conference calls, Regional Work Group and Task Group meetings for the current code development cycle, which included members of the committees as well as any interested parties, to discuss and debate the proposed changes. Related documentation and reports are posted on the FCAC website at: <https://www.iccsafe.org/codes-tech-support/cs/fire-code-action-committee-fcac/>

Cost Impact

The code change proposal will not increase or decrease the cost of construction .

. This is a correlation between the IFC and IBC with no technical change.

Internal ID: 515

E49-18

IBC: 202 (New), 1010.1.4.6 (New), (IFC[BE] 202 (New), 1010.1.4.6(New))

Proponent: John Woestman, Kellen Co., representing Builders Hardware Manufacturers Association (BHMA) (jwoestman@kellencompany.com)

2018 International Building Code

Add new definition as follows:

CONTROL VESTIBULE. A space with door locking arrangements of interlocked doors in series such that while one door of the control vestibule is open, the other door in series is temporarily locked.

Add new text as follows:

1010.1.4.6 Control vestibule. Where doors in the means of egress are configured as a control vestibule, the door locking system shall provide for emergency egress and shall be subject to approval by the building official. A control vestibule in the means of egress shall comply with all of the following.

1. An approved override shall be provided on the egress side of each door of a control vestibule.
2. An approved override shall be provided on the ingress side of the outer door of a control vestibule.
3. Upon activation of the automatic sprinkler system or automatic fire detection system, the interlock function of the door locking system shall deactivate.
4. Upon loss of power to the interlock function of the doors, the interlock function of the door locking system shall deactivate.
5. The egress path from any point shall not pass through more than one control vestibule unless approved by the code official.
6. The door locking system units shall be listed in accordance with UL 294.

Reason:

We are proposing a definition for “control vestibule” and proposing detailed requirements for control vestibules.

The significant difference between doors in series in the means of egress (i.e. one after the other) and doors in the means of egress configured as a control vestibule is the doors of a control vestibule are interlocked such that when one door of a control vestibule is open, the other door in series in the control vestibule is temporarily locked; and conversely, in the means of egress when all doors of a control vestibule are closed, any door may be opened.

Control vestibules are most commonly configured as a space with two doors in series. But, some control vestibules are configured with more than one inner door and / or more than one outer door. For example, where a control vestibule is required to help keep clean rooms clean, there may be inner doors from three different clean rooms opening into the control vestibule, and one outer door for leaving the control vestibule in the direction of egress.

The proposed requirements for control vestibules are for these reasons:

Item 1: A requirement to address the potential situation where one of the doors on the control vestibule is held open (example: a person faints in the outer doorway), other occupants may need to be able to egress through the control vestibule, especially in emergency situations. It is common the activation of an override would set off an alarm, and / or the activation of an override without a valid reason results in disciplinary action (i.e. employee gets fired).

Item 2: In the event the inner door of a control vestibule is held open (example: a person faints at the inner door), an override allows access into the control vestibule. The required override on the ingress side of the outer door allows for emergency access into the control vestibule, if needed. This override commonly requires a higher level of authorization for use and / or is provided for responding emergency crews.

Items 3 and 4: Requires the interlock function to be disabled in the event of fire, actuation of the fire detection system, or power loss to the interlock system rendering the control vestibule equivalent to two doors in the means of egress allowing unobstructed egress.

Item 5: Requires that egressing through the control vestibule involves no more than two doors, unless approved by the code official. While not common, there are situations where more than one control vestibule may be needed in the means of egress.

Item 6: Requires the units of the control vestibule locking system to be listed in accordance with UL 294, the same standard required for units for other electrical locking system units.

Together, the definition and proposed requirements provide for egress and emergency egress where control vestibules are installed.

Note: a control vestibule is different than a sallyport, which is defined in the IBC and permitted in Group I-3 occupancies. Group I-3 includes correction centers, detention centers, jails, prisons, and similar uses. A sallyport is a security vestibule which prevents unobstructed passage. A control vestibule is intended to allow unobstructed passage, but prevents more than one door of doors in series to be open at the same time.

Cost Impact

The code change proposal will decrease the cost of construction .

Control vestibules are currently not addressed in the code. Where control vestibules are constructed, these requirements may include some locking requirements and interconnectedness currently not incorporated into some control vestibules.

Internal ID: 2326

E50-18

IBC: 1010.1.8 (New), (IFC[BE] 1010.1.8(New))

Proponent: Matthew Rowley, Frederick County Government, representing Frederick County Government
(matt@frederickcountymd.gov)

2018 International Building Code

Add new text as follows:

1010.1.8 Doors in infant care areas. All swinging doors serving rooms used for the care of children 2 1/2 years or less of age shall be equipped with door sweeps or a continuous rubber gasket running the entire underside of the door.

Reason:

An acquaintance opened a door when he returned home, not knowing his infant son was crawling on the floor on the other side of the door. His son's fingers were severed when they were caught underneath the swinging door.

I'm concerned for the safety of crawling children in similar situations.

Cost Impact

The code change proposal will increase the cost of construction .

The increased cost will be minimal. Door sweeps can be purchased for less than \$10.00 apiece.

Internal ID: 1450

E51-18

IBC: 1010.1.9 (New), (IFC[BE] 1010.1.9 (New))

Proponent: Ed Kullik, representing ICC Building Code Action Committee (bcac@iccsafe.org)

2018 International Building Code

Add new text as follows:

1010.1.9 Vestibules. Where required by a compliance path of the International Energy Conservation Code, building entrances shall be provided with vestibules.

Reason:

The IECC requires vestibules to be provided at building entrances in all climate zones other than 1 and 2. In the design of buildings this can be a significant feature of entrances. The requirement can be overlooked by designers if they focus on the IBC during initial design and then are perhaps surprised by the requirement when adding the IECC to their construction documents. This proposal provides a direct reference to the compliance paths in the IECC for vestibules.

The proposal puts the reference for vestibules in Chapter 10 after the section for door arrangements (Section 1010.1.8). Since Section 1010.1.8 addresses doors in a series, this is the most logical place for designers to understand that a vestibule may be required by the IECC.

The BCAC developed this proposal with the SEHPCAC. This proposal is submitted by the ICC Building Code Action Committee (BCAC). BCAC was established by the ICC Board of Directors in July 2011 to pursue opportunities to improve and enhance assigned International Codes or portions thereof. In 2017 the BCAC has held 3 open meetings. In addition, there were numerous Working Group meetings and conference calls for the current code development cycle, which included members of the committee as well as any interested party to discuss and debate the proposed changes. Related documentation and reports are posted on the BCAC website at: <https://www.iccsafe.org/codes-tech-support/codes/codedevelopment-process/building-code-action-committee-bcac>.

Cost Impact

The code change proposal will not increase or decrease the cost of construction .

This requirement already exists in the IECC. Inclusions in the IBC doesn't result in any construction not already anticipated.

Internal ID: 527

E52-18

IBC: 1010.1.9.4, (IFC[BE] 1010.1.9.4)

Proponent: John Williams, Chair, representing Healthcare Committee (AHC@iccsafe.org)

2018 International Building Code

Revise as follows:

1010.1.9.4 Locks and latches. Locks and latches shall be permitted to prevent operation of doors where any of the following exist:

1. Places of detention or restraint.
2. In Group I-1 Condition 2 and Group I-2 occupancies where the clinical needs of persons receiving care require containment or where persons receiving care pose a security threat, provided that clinical staff can readily unlock doors at all times, and all such locks are keyed to keys carried by clinical staff at all times or clinical staff have the codes or other means necessary to operate the locks at all times.
- ~~3.2.~~ In buildings in occupancy Group A having an *occupant load* of 300 or less, Groups B, F, M and S, and in *places of religious worship*, the main door or doors are permitted to be equipped with key-operated locking devices from the egress side provided:
 - ~~3.1. 2.1.~~The locking device is readily distinguishable as locked.
 - ~~3.2. 2.2.~~A readily visible durable sign is posted on the egress side on or adjacent to the door stating: THIS DOOR TO REMAIN UNLOCKED WHEN THIS SPACE IS OCCUPIED. The sign shall be in letters 1 inch (25 mm) high on a contrasting background.
 - ~~3.3. 2.3.~~The use of the key-operated locking device is revocable by the *building official* for due cause.
- ~~4.~~ ~~3.~~Where egress doors are used in pairs, *approved* automatic flush bolts shall be permitted to be used, provided that the door leaf having the automatic flush bolts does not have a doorknob or surface-mounted hardware.
- ~~5.~~ ~~4.~~Doors from individual *dwelling* or *sleeping units* of Group R occupancies having an *occupant load* of 10 or less are permitted to be equipped with a night latch, dead bolt or security chain, provided such devices are operable from the inside without the use of a key or tool.
- ~~6.~~ ~~5.~~*Fire doors* after the minimum elevated temperature has disabled the unlatching mechanism in accordance with *listed fire door* test procedures.
- ~~7.~~ ~~6.~~Doors serving roofs not intended to be occupied shall be permitted to be locked preventing entry to the building from the roof.

Reason:

This manual locking provision recognizes what is currently permitted under the Federal Standards and Centers for Medicaid and Medicare Services enforcement rules where the restraint of patients is allowed for the safety of the patient and/or the public (K222). This may be needed as part of the progression of treatment for patients.

This proposal is submitted by the ICC Committee on Healthcare (CHC). The CHC was established by the ICC Board to evaluate and assess contemporary code issues relating to healthcare facilities. This is a joint effort between ICC and the American Society for Healthcare Engineering (ASHE), a subsidiary of the American Hospital Association, to eliminate duplication and conflicts in healthcare regulation. In 2017 the CHC held 2 open meetings and numerous conference calls

Cost Impact

The code change proposal will not increase or decrease the cost of construction .

As a permitted condition the cost impact only occurs if the option is exercised.

Internal ID: 589

E53-18

IBC: 1010.1.9.4, 1010.1.10, (IFC[BE] 1010.1.9.4, 1010.1.10); IFC 1031.8

Proponent: Lee Kranz, representing Washington Association of Building Officials Technical Code Development Committee (lkranz@bellevuewa.gov)

2018 International Building Code

Revise as follows:

1010.1.9.4 Locks and latches. Locks and latches shall be permitted to prevent operation of doors where any of the following exist:

1. Places of detention or restraint.
2. In buildings in occupancy Group A having an *occupant load* of 300 or less, Groups B, F, M and S, and in *places of religious worship*, the main door or doors are permitted to be equipped with key-operated locking devices from the egress side provided:
 - 2.1. The locking device is readily distinguishable as locked.
 - 2.2. A readily visible durable sign is posted on the egress side on or adjacent to the door stating: THIS DOOR TO REMAIN UNLOCKED WHEN THIS SPACE IS OCCUPIED. The sign shall be in letters 1 inch (25 mm) high on a contrasting background.
 - 2.3. The use of the key-operated locking device is revocable by the *building official* for due cause.
3. Where egress doors are used in pairs, *approved* automatic flush bolts shall be permitted to be used, provided that the door leaf having the automatic flush bolts does not have a doorknob or surface-mounted hardware.
4. Doors from individual *dwelling* or *sleeping units* of Group R occupancies having an *occupant load* of 10 or less are permitted to be equipped with a night latch, dead bolt or security chain, provided such devices are openable from the inside without the use of a key or tool.
5. *Fire doors* after the minimum elevated temperature has disabled the unlatching mechanism in accordance with *listed fire door* test procedures.
6. Doors serving roofs not intended to be occupied shall be permitted to be locked preventing entry to the building from the roof.
7. Other than egress courts, where occupants must egress from an exterior space through the building for means of egress, exit access doors shall be permitted to be equipped with an approved locking device where installed and operated in accordance with all of the following:
 - 7.1. The maximum occupant load shall be posted where required by Section 1004.9. Such sign shall be permanently affixed inside the building and shall be posted in a conspicuous space near all the exit access doorways.
 - 7.2. A weatherproof telephone or two-way communication system installed in accordance with Sections 1009.8.1 and 1009.8.2 shall be located adjacent to not less than one required exit access door on the exterior side.
 - 7.3. The egress door locking device is readily distinguishable as locked and shall be a key-operated locking device.
 - 7.4. A clear window or glazed door opening, not less than 5 square feet (0.46 m²) sq. ft. in area, shall be provided at each exit access door to determine if there are occupants using the outdoor area.
 - 7.5. A readily visible durable sign shall be posted on the interior side on or adjacent to each locked required exit access door serving the exterior area stating: THIS DOOR TO REMAIN UNLOCKED WHEN THE OUTDOOR AREA IS OCCUPIED. The letters on the sign shall be not less than 1" high on a contrasting background.
8. Locking devices are permitted on doors to balconies, decks or other exterior spaces serving individual dwelling or sleeping units.
9. Locking devices are permitted on doors to balconies, decks or other exterior spaces of 250 square feet or less, serving a private office space.

1010.1.10 Panic and fire exit hardware. Swinging doors serving a Group H occupancy and swinging doors serving rooms or spaces with an *occupant load* of 50 or more in a Group A or E occupancy shall not be provided with a latch or lock other than *panic hardware* or *fire exit hardware*.

Exceptions:

1. A main exit of a Group A occupancy shall be permitted to have locking devices in accordance with Section 1010.1.9.4, Item 2.
2. Doors provided with *panic hardware* or *fire exit hardware* and serving a Group A or E occupancy shall be permitted to be electrically locked in accordance with Section 1010.1.9.9 or 1010.1.9.10.
3. Exit access doors serving occupied exterior areas shall be permitted to be locked in accordance with Section 1010.1.9.4, Item 7.

Electrical rooms with equipment rated 1,200 amperes or more and over 6 feet (1829 mm) wide, and that contain overcurrent devices, switching devices or control devices with exit or *exit access* doors, shall be equipped with *panic hardware* or *fire exit hardware*. The doors shall swing in the direction of egress travel.

2018 International Fire Code

Revise as follows:

1031.8 Inspection, testing and maintenance. Two-way communication systems ~~for areas of refuge~~ shall be inspected and tested on a yearly basis to verify that all components are operational. Where required, the tests shall be conducted in the presence of the *fire code official*. Records of inspection, testing and maintenance shall be maintained.

Reason:

IBC Section 1004.7 requires an unobstructed path of egress from outdoor areas where single or multiple paths of egress travel are required to pass back through the building. Currently egress doors serving outdoor areas are not permitted to have locks. For security purposes, building owners and tenants install locks on required egress doors from these areas in violation of the code. Many building officials and fire officials allow locks and latches on doors serving the outdoor areas using the modification provisions of Sections 104.10 & 104.11. Since installation of locks on egress doors occurs on a regular basis it makes sense to provide a safe, reasonable and consistent standard to follow for the safety of people occupying outdoor areas who must re-enter the building for egress.

Additional safety is provided by requiring a two-way communication system, allowing occupants to call for help if the egress door is accidentally locked. Two-way communication system requirements are currently found in IBC Section 1009.8.1 & 1009.8.2.

The sketch below illustrates an occupied exterior deck where occupants must egress through the building to reach the exit discharge. The deck shown is on the 3rd story of the building where the installation of an exterior stairway is not practical. The owner has requested to install security locks on the exit access doors but IBC Section 1004.5 clearly requires that occupants be able to egress from the deck at all times. This proposal would allow the doors to be locked if the specified safety measures are met.

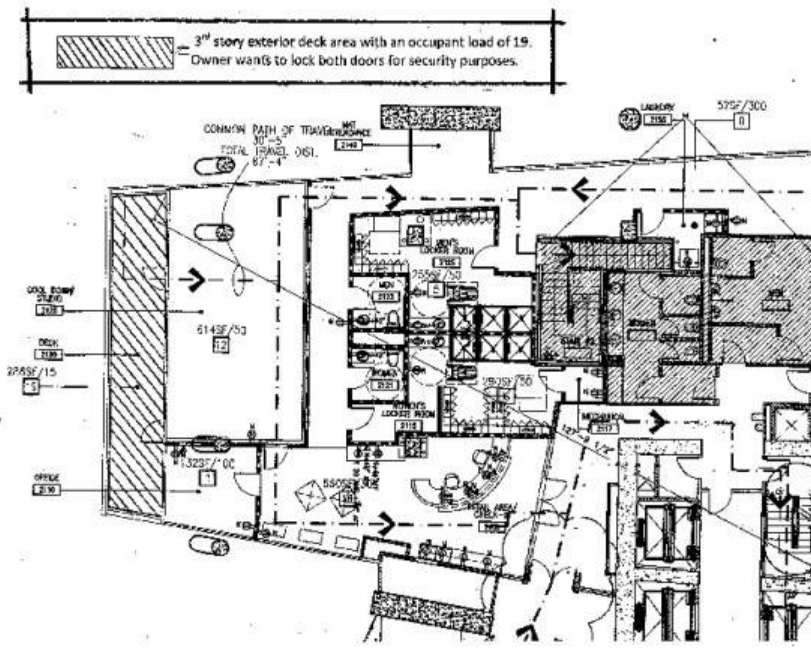

IFC Section 1030.8 - If this proposal passes, the two-way communication system needs to be tested and maintained. The IFC language is currently only for systems in areas of refuge.

Cost Impact

The code change proposal will not increase or decrease the cost of construction .

It is hard to say if this code change will increase or decrease the cost of construction. Compliance with the proposed conditions of approval (2-way communication device, vision glass, signage, etc) would increase costs but many of these improvements are being required as a result of alternate means and methods of construction requirements that occur when violations are discovered by Fire Prevention Officers after the C of O is issued. In those cases the cost to make these improvements will be higher then if they had been made during the initial construction of the building.

Internal ID: 95

E54-18

IBC: 1010.1.9.6, Chapter 35, (IFC[BE] 1010.1.9.6, Chapter 80)

Proponent: John Woestman, Kellen Co., representing Builders Hardware Manufacturers Association (BHMA)
(jwoestman@kellencompany.com)

2018 International Building Code

Revise as follows:

1010.1.9.6 Unlatching. The unlatching of any door or leaf for egress shall require not require more than one ~~operation~~ motion in a single linear or rotational direction to release all latching and all locking devices. Latching or locking devices shall comply with ANSI/BHMA A156.41.

Exceptions:

1. Places of detention or restraint.
2. Where manually operated bolt locks are permitted by Section 1010.1.9.5.
3. Doors with automatic flush bolts as permitted by Section 1010.1.9.4, Item 3.
4. Doors from individual *dwelling units* and *sleeping units* of Group R occupancies as permitted by Section 1010.1.9.4, Item 4.

Add new standard(s) follows:

BHMA

Builders Hardware Manufacturers'
Association
355 Lexington Avenue, 15th Floor
New York NY 10017-6603
US

A156.41-2013:

Door Controls-Closers

Reason:

Code officials, specifiers, building owners, and security professions have been asking questions regarding what is required and what is permitted by the current language of 1010.1.9.6. This proposal is an attempt to address these questions, and provide more specifics as to what is meant by “not more than one operation” currently required by the code.

Also, this proposal introduces ANSI/BHMA A156.41 Door Hardware Single Motion to Egress into the IBC, as a requirement for door hardware used on doors in the means of egress, and performance requirements for manufacturers of door hardware.

Cost Impact

The code change proposal will increase the cost of construction .

Manufacturers will need to demonstrate compliance to A156.41, which may entail minimal cost to do so. On the other hand, these modifications should reduce ambiguity and questions during the design, construction, and code inspection process.

Analysis: A review of the standard proposed for inclusion in the code, ANSI/BMHA A156.41-2013, with regard to the ICC criteria for referenced standards (Section 3.6 of CP#28) will be posted on the ICC website on or before April 2, 2018.

Internal ID: 2320

E55-18

IBC: 1010.1.9.7, (IFC[BE] 1010.1.9.7)

Proponent: John Williams, Chair, representing Healthcare Committee (AHC@iccsafe.org)

2018 International Building Code

Revise as follows:

1010.1.9.7 Controlled egress doors in Groups I-1 and I-2. Electric locking systems, including electro-mechanical locking systems and electromagnetic locking systems, shall be permitted to be locked in the *means of egress* in Group I-1 or I-2 occupancies where the clinical needs of persons receiving care require their containment. Controlled egress doors shall be permitted in such occupancies where the building is equipped throughout with an *automatic sprinkler system* in accordance with Section 903.3.1.1 or an *approved automatic smoke or heat-detection system* installed in accordance with Section 907, provided that the doors are installed and operate in accordance with all of the following:

1. The door locks shall unlock on actuation of the *automatic sprinkler system* or *automatic fire-smoke detection system*.
2. The door locks shall unlock on loss of power controlling the lock or lock mechanism.
3. The door locking system shall be installed to have the capability of being unlocked by a switch located at the *fire command center*, a nursing station or other *approved* location. The switch shall directly break power to the lock.
4. A building occupant shall not be required to pass through more than one door equipped with a controlled egress locking system before entering an exit.
5. The procedures for unlocking the doors shall be described and *approved* as part of the emergency planning and preparedness required by Chapter 4 of the International Fire Code.
6. All clinical staff shall have the keys, codes or other means necessary to operate the locking systems.
7. Emergency lighting shall be provided at the door.
8. The door locking system units shall be *listed* in accordance with UL 294.

Exceptions:

1. Items 1 through 4 shall not apply to doors to areas occupied by persons who, because of clinical needs, require restraint or containment as part of the function of a psychiatric treatment area.
2. Items 1 through 4 shall not apply to doors to areas where a *listed* egress control system is utilized to reduce the risk of child abduction from nursery and obstetric areas of a Group I-2 hospital.

Reason:

This clarification of language is required in order to conform with Federal Standards and Centers for Medicaid and Medicare Services enforcement rules (K221). The two control features are automatic fire suppression and smoke detection; this provision aligns with recognized federal standards. Where ambient conditions affect the performance of smoke detection Section 907.4.3 provides the opportunity for heat detection.

This proposal is submitted by the ICC Committee on Healthcare (CHC). The CHC was established by the ICC Board to evaluate and assess contemporary code issues relating to healthcare facilities. This is a joint effort between ICC and the American Society for Healthcare Engineering (ASHE), a subsidiary of the American Hospital Association, to eliminate duplication and conflicts in healthcare regulation. In 2017 the CHC held 2 open meetings and numerous conference calls, which included members of the committees as well as any interested parties, to discuss and debate the proposed changes. Information on the CHC, including: meeting agendas; minutes; reports; resource documents; presentations; and all other materials developed in conjunction with the CHC effort can be downloaded from the CHC website at: <https://www.iccsafe.org/codes-tech-support/cs/icc-committee-on-healthcare/>.

Cost Impact

The code change proposal will not increase or decrease the cost of construction .

Detection device installation is already prescribed.

Internal ID: 584

E56-18

IBC: 1010.1.9.7, 1010.1.9.8.1, 1010.1.9.9, Chapter 35, (IFC[BE] 1010.1.9.7, 1010.1.9.8.1, 1010.1.9.9, Chapter 80)

Proponent: Jonathan Roberts, UL LLC, representing UL LLC (jonathan.roberts@ul.com)

2018 International Building Code

Revise as follows:

1010.1.9.7 Controlled egress doors in Groups I-1 and I-2. Electric locking systems, including electro-mechanical locking systems and electromagnetic locking systems, shall be permitted to be locked in the *means of egress* in Group I-1 or I-2 occupancies where the clinical needs of persons receiving care require their containment. Controlled egress doors shall be permitted in such occupancies where the building is equipped throughout with an *automatic sprinkler system* in accordance with Section 903.3.1.1 or an *approved automatic smoke or heat detection system* installed in accordance with Section 907, provided that the doors are installed and operate in accordance with all of the following:

1. The door locks shall unlock on actuation of the *automatic sprinkler system* or *automatic fire detection system*.
2. The door locks shall unlock on loss of power controlling the lock or lock mechanism.
3. The door locking system shall be installed to have the capability of being unlocked by a switch located at the *fire command center*, a nursing station or other *approved* location. The switch shall directly break power to the lock.
4. A building occupant shall not be required to pass through more than one door equipped with a controlled egress locking system before entering an exit.
5. The procedures for unlocking the doors shall be described and *approved* as part of the emergency planning and preparedness required by Chapter 4 of the International Fire Code.
6. All clinical staff shall have the keys, codes or other means necessary to operate the locking systems.
7. Emergency lighting shall be provided at the door.
8. The electric egress door locking system units shall be listed in accordance with UL 294. Electric locks or electronic locking mechanisms shall be listed in accordance with UL1034.

Exceptions:

1. Items 1 through 4 shall not apply to doors to areas occupied by persons who, because of clinical needs, require restraint or containment as part of the function of a psychiatric treatment area.
2. Items 1 through 4 shall not apply to doors to areas where a *listed* egress control system is utilized to reduce the risk of child abduction from nursery and obstetric areas of a Group I-2 hospital.

1010.1.9.8.1 Delayed egress locking system. The delayed egress locking system shall be installed and operated in accordance with all of the following:

1. The delay electronics of the delayed egress locking system shall deactivate upon actuation of the *automatic sprinkler system* or *automatic fire detection system*, allowing immediate free egress.
2. The delay electronics of the delayed egress locking system shall deactivate upon loss of power controlling the lock or lock mechanism, allowing immediate free egress.
3. The delayed egress locking system shall have the capability of being deactivated at the *fire command center* and other *approved* locations.
4. An attempt to egress shall initiate an irreversible process that shall allow such egress in not more than 15 seconds when a physical effort to exit is applied to the egress side door hardware for not more than 3 seconds. Initiation of the irreversible process shall activate an audible signal in the vicinity of the door. Once the delay electronics have been deactivated, rearming the delay electronics shall be by manual means only.

Exception: Where *approved*, a delay of not more than 30 seconds is permitted on a delayed egress door.

5. The egress path from any point shall not pass through more than one delayed egress locking system.

Exceptions:

1. In Group I-2 or I-3 occupancies, the egress path from any point in the building shall pass through not more than two delayed egress locking systems provided that the combined delay does not exceed 30 seconds.
 2. In Group I-1 or I-4 occupancies, the egress path from any point in the building shall pass through not more than two delayed egress locking systems provided the combined delay does not exceed 30 seconds and the building is equipped throughout with an *automatic sprinkler system* in accordance with Section 903.3.1.1.
6. A sign shall be provided on the door and shall be located above and within 12 inches (305 mm) of the door exit hardware:
 - 6.1. For doors that swing in the direction of egress, the sign shall read: PUSH UNTIL ALARM SOUNDS. DOOR CAN BE OPENED IN 15 [30] SECONDS.
 - 6.2. For doors that swing in the opposite direction of egress, the sign shall read: PULL UNTIL ALARM SOUNDS. DOOR CAN BE OPENED IN 15 [30] SECONDS.
 - 6.3. The sign shall comply with the visual character requirements in ICC A117.1.

Exception: Where *approved*, in Group I occupancies, the installation of a sign is not required where care recipients who because of clinical needs require restraint or containment as part of the function of the treatment area.
 7. Emergency lighting shall be provided on the egress side of the door.
 8. The delayed egress locking system units shall be *listed* in accordance with UL 294. Where door locking systems are also required to comply with Section 1010.1.10, the door locking system shall be listed in accordance with UL 294 and UL 305.

1010.1.9.9 Sensor release of electrically locked egress doors. Sensor release of electric locking systems shall be permitted on doors located in the *means of egress* in any occupancy except Group H where installed and operated in accordance with all of the following criteria:

1. The sensor shall be installed on the egress side, arranged to detect an occupant approaching the doors, and shall cause the electric locking system to unlock.
2. The electric locks shall be arranged to unlock by a signal from or loss of power to the sensor.
3. Loss of power to the lock or locking system shall automatically unlock the electric locks.
4. The doors shall be arranged to unlock from a manual unlocking device located 40 inches to 48 inches (1016 mm to 1219 mm) vertically above the floor and within 5 feet (1524 mm) of the secured doors. Ready access shall be provided to the manual unlocking device and the device shall be clearly identified by a sign that reads "PUSH TO EXIT". When operated, the manual unlocking device shall result in direct interruption of power to the electric lock-independent of other electronics-and the electric lock shall remain unlocked for not less than 30 seconds.
5. Activation of the building *fire alarm system*, where provided, shall automatically unlock the electric lock, and the electric lock shall remain unlocked until the *fire alarm system* has been reset.
6. Activation of the building *automatic sprinkler system* or fire detection system, where provided, shall automatically unlock the electric lock. The electric lock shall remain unlocked until the *fire alarm system* has been reset.
7. The door locking system units shall be *listed* in accordance with UL 294. Where door locking systems are also required to comply with Section 1010.1.10, the door locking system shall be listed in accordance with UL 294 and UL 305.

Add new standard(s) follows:

1034-11:

Standard for Burglary-Resistant Electric Locking Mechanisms - with revisions through 2015

Reason:

There has been confusion about UL 294 being used to list all portions of the electric door locking systems covered by this section. This proposal clarifies that the system units be listed to UL 294, and that the electric locking mechanisms (mag locks) be listed to UL 1034.

Cost Impact

The code change proposal will not increase or decrease the cost of construction .

This proposal is editorial only and provides clarification to existing requirements for hardware listing.

Analysis: A review of the standard proposed for inclusion in the code, UL 1034-11, with regard to the ICC criteria for referenced standards (Section 3.6 of CP#28) will be posted on the ICC website on or before April 2, 2018.

Internal ID: 231

E57-18

IBC: 1010.1.9.7, (IFC[BE] 1010.1.9.7)

Proponent: John Williams, Chair, representing Healthcare Committee (AHC@iccsafe.org)

2018 International Building Code

Revise as follows:

1010.1.9.7 Controlled egress doors in Groups I-1 and I-2. Electric locking systems, including electro-mechanical locking systems and electromagnetic locking systems, shall be permitted to be locked in the *means of egress* in Group I-1 or I-2 occupancies where the clinical needs of persons receiving care require their containment. Controlled egress doors shall be permitted in such occupancies where the building is equipped throughout with an *automatic sprinkler system* in accordance with Section 903.3.1.1 or an *approved automatic smoke or heat detection system* installed in accordance with Section 907, provided that the doors are installed and operate in accordance with all of the following:

1. The door locks shall unlock on actuation of the *automatic sprinkler system* or *automatic fire detection system*.
2. The door locks shall unlock on loss of power controlling the lock or lock mechanism.
3. The door locking system shall be installed to have the capability of being unlocked by a switch located at the *fire command center*, a nursing station or other *approved* location. The switch shall directly break power to the lock.
4. A building occupant shall not be required to pass through more than one door equipped with a controlled egress locking system before entering an exit.
5. The procedures for unlocking the doors shall be described and *approved* as part of the emergency planning and preparedness required by Chapter 4 of the International Fire Code.
6. All clinical staff shall have the keys, codes or other means necessary to operate the locking systems.
7. Emergency lighting shall be provided at the door.
8. The door locking system units shall be *listed* in accordance with UL 294.

Exceptions:

1. Items 1 through 4 shall not apply to doors to areas occupied by persons who, because of clinical needs, require restraint or containment as part of the function of a psychiatric or cognitive treatment area.
2. Items 1 through 4 shall not apply to doors to areas where a *listed* egress control system is utilized to reduce the risk of child abduction from nursery and obstetric areas of a Group I-2 hospital.

Reason:

The addition of 'cognitive' is so this option is available for Alzheimer and dementia wards where there are clinical needs. This locking arrangement is only for areas where the staff controls the locking arrangements.

This proposal is submitted by the ICC Committee on Healthcare (CHC). The CHC was established by the ICC Board to evaluate and assess contemporary code issues relating to healthcare facilities. This is a joint effort between ICC and the American Society for Healthcare Engineering (ASHE), a subsidiary of the American Hospital Association, to eliminate duplication and conflicts in healthcare regulation. In 2017 the CHC held 2 open meetings and numerous conference calls, which included members of the committees as well as any interested parties, to discuss and debate the proposed changes. Information on the CHC, including: meeting agendas; minutes; reports; resource documents; presentations; and all other materials developed in conjunction with the CHC effort can be downloaded from the CHC website at: <https://www.iccsafe.org/codes-tech-support/cs/icc-committee-on-healthcare/>.

Cost Impact

The code change proposal will not increase or decrease the cost of construction .

This takes away requirements if the clinical needs justify same.

Internal ID: 585

E58-18

IBC: 1010.1.9.8, 1010.1.10, (IFC[BE] 1010.1.9.8, 1010.1.10)

Proponent: Ed Kullik, Chair, representing ICC Building Code Action Committee (bcac@iccsafe.org)

2018 International Building Code

Revise as follows:

1010.1.9.8 Delayed egress. Delayed egress locking systems shall be permitted to be installed on doors serving the following occupancies in buildings that are equipped throughout with an *automatic sprinkler system* in accordance with Section 903.3.1.1 or an *approved automatic smoke or heat detection system* installed in accordance with Section 907.

1. Group B, F, I, M, R, S and U occupancies.
2. Group E classrooms with an *occupant load* of less than 50.

~~**Exception:** Delayed~~

3. In a courthouse, delayed egress locking systems shall be permitted to be installed on exit or *exit access* doors, other than the main exit or *exit access* door, serving a Group A-3 courtroom in buildings equipped throughout with an *automatic sprinkler system* in accordance with Section 903.3.1.1.

1010.1.10 Panic and fire exit hardware. Swinging doors serving a Group H occupancy and swinging doors serving rooms or spaces with an *occupant load* of 50 or more in a Group A or E occupancy shall not be provided with a latch or lock other than *panic hardware* or *fire exit hardware*.

Exceptions:

1. A main exit of a Group A occupancy shall be permitted to have locking devices in accordance with Section 1010.1.9.4, Item 2.
2. Doors provided with *panic hardware* or *fire exit hardware* and serving a Group A or E occupancy shall be permitted to be electrically locked in accordance with Section 1010.1.9.9 or 1010.1.9.10.
3. Courtrooms shall be permitted to be locked in accordance with Section 1010.1.9.8, Item 3.

Electrical rooms with equipment rated 1,200 amperes or more and over 6 feet (1829 mm) wide, and that contain overcurrent devices, switching devices or control devices with exit or *exit access* doors, shall be equipped with *panic hardware* or *fire exit hardware*. The doors shall swing in the direction of egress travel.

Reason:

This is only a format issue resulting from the multiple changes last cycle to the delayed egress locks - E66-15 AMPC1, E68-15 AM/AMPC1, E69-15 AS. The allowance for courtrooms, while logical, is out of place as an exception to Items 1 and 2 in Section 1010.1.9.8.

Correlation with Section 1010.1.9.8 in Section 1010.1.10 is needed because this is Group A where panic hardware is otherwise required.

This proposal is submitted by the ICC Building Code Action Committee (BCAC). BCAC was established by the ICC Board of Directors in July 2011 to pursue opportunities to improve and enhance assigned International Codes or portions thereof. In 2017 the BCAC has held 3 open meetings. In addition, there were numerous Working Group meetings and conference calls for the current code development cycle, which included members of the committee as well as any interested party to discuss and debate the proposed changes. Related documentation and reports are posted on the BCAC website at: <https://www.iccsafe.org/codes-tech-support/codes/codedevelopment-process/building-code-action-committee-bcac>.

Cost Impact

The code change proposal will not increase or decrease the cost of construction .

This is a format revision with no change to technical criteria.

Internal ID: 514

E59-18

IBC: 1010.1.9.8.1, (IFC[BE] 1010.1.9.8.1)

Proponent: John Williams, Chair, representing Healthcare Committee (AHC@iccsafe.org)

2018 International Building Code

Revise as follows:

1010.1.9.8.1 Delayed egress locking system. The delayed egress locking system shall be installed and operated in accordance with all of the following:

1. The delay electronics of the delayed egress locking system shall deactivate upon actuation of the *automatic sprinkler system* or *automatic fire detection system*, allowing immediate free egress.
2. The delay electronics of the delayed egress locking system shall deactivate upon loss of power controlling the lock or lock mechanism, allowing immediate free egress.
3. The delayed egress locking system shall have the capability of being deactivated at the *fire command center* and other *approved* locations.
4. An attempt to egress shall initiate an irreversible process that shall allow such egress in not more than 15 seconds when a physical effort to exit is applied to the egress side door hardware for not more than 3 seconds. Initiation of the irreversible process shall activate an audible signal in the vicinity of the door. Once the delay electronics have been deactivated, rearming the delay electronics shall be by manual means only.

Exception: Where *approved*, a delay of not more than 30 seconds is permitted on a delayed egress door.

5. The egress path from any point shall not pass through more than one delayed egress locking system.

Exceptions:

1. In Group I-1, Condition 2, Group I-2 or I-3 occupancies, the egress path from any point in the building shall pass through not more than two delayed egress locking systems provided that the combined delay does not exceed 30 seconds.
2. In Group I-1, Condition 1 or I-4 occupancies, the egress path from any point in the building shall pass through not more than two delayed egress locking systems provided the combined delay does not exceed 30 seconds and the building is equipped throughout with an *automatic sprinkler system* in accordance with Section 903.3.1.1.

6. A sign shall be provided on the door and shall be located above and within 12 inches (305 mm) of the door exit hardware:

- 6.1. For doors that swing in the direction of egress, the sign shall read: PUSH UNTIL ALARM SOUNDS. DOOR CAN BE OPENED IN 15 [30] SECONDS.
- 6.2. For doors that swing in the opposite direction of egress, the sign shall read: PULL UNTIL ALARM SOUNDS. DOOR CAN BE OPENED IN 15 [30] SECONDS.
- 6.3. The sign shall comply with the visual character requirements in ICC A117.1.

Exception: Where *approved*, in Group I occupancies, the installation of a sign is not required where care recipients who because of clinical needs require restraint or containment as part of the function of the treatment area.

7. Emergency lighting shall be provided on the egress side of the door.
8. The delayed egress locking system units shall be *listed* in accordance with UL 294.

Reason:

Group I-1 Condition 2 is already required to be protected with an NFPA13 automatic fire suppression system, so it should be grouped with Group I-2 and I-3. The second exception recognizes occupancy Group I-1 Condition 1 and I-4 is based on the inclusion of an automatic fire suppression sprinkler system NFPA13 system, which is above the

allowances for NFPA13R for Group I-1, Condition 1 and no sprinklers for some Group I-4.

This proposal is submitted by the ICC Committee on Healthcare (CHC). The CHC was established by the ICC Board to evaluate and assess contemporary code issues relating to healthcare facilities. This is a joint effort between ICC and the American Society for Healthcare Engineering (ASHE), a subsidiary of the American Hospital Association, to eliminate duplication and conflicts in healthcare regulation. In 2017 the CHC held 2 open meetings and numerous conference calls, which included members of the committees as well as any interested parties, to discuss and debate the proposed changes. Information on the CHC, including: meeting agendas; minutes; reports; resource documents; presentations; and all other materials developed in conjunction with the CHC effort can be downloaded from the CHC website at: <https://www.iccsafe.org/codes-tech-support/cs/icc-committee-on-healthcare/>.

Cost Impact

The code change proposal will not increase or decrease the cost of construction .

This is a clarification, not a new requirement.

Internal ID: 586

E60-18

IBC: 1010.1.9.8.1, Chapter 35, (IFC[BE] 1010.1.9.8.1, Chapter 80)

Proponent: John Woestman, Kellen Co., representing Builders Hardware Manufacturers Association (BHMA)
(jwoestman@kellencompany.com)

2018 International Building Code

Revise as follows:

1010.1.9.8.1 Delayed egress locking system. The delayed egress locking system shall be installed and operated in accordance with all of the following:

1. The delay electronics of the delayed egress locking system shall deactivate upon actuation of the *automatic sprinkler system* or *automatic fire detection system*, allowing immediate free egress.
2. The delay electronics of the delayed egress locking system shall deactivate upon loss of power controlling the lock or lock mechanism, allowing immediate free egress.
3. The delayed egress locking system shall have the capability of being deactivated at the *fire command center* and other *approved* locations.
4. An attempt to egress shall initiate an irreversible process that shall allow such egress in not more than 15 seconds when a physical effort to exit is applied to the egress side door hardware for not more than 3 seconds. Initiation of the irreversible process shall activate an audible signal in the vicinity of the door. Once the delay electronics have been deactivated, rearming the delay electronics shall be by manual means only.

Exception: Where *approved*, a delay of not more than 30 seconds is permitted on a delayed egress door.

5. The egress path from any point shall not pass through more than one delayed egress locking system.

Exceptions:

1. In Group I-2 or I-3 occupancies, the egress path from any point in the building shall pass through not more than two delayed egress locking systems provided that the combined delay does not exceed 30 seconds.
2. In Group I-1 or I-4 occupancies, the egress path from any point in the building shall pass through not more than two delayed egress locking systems provided the combined delay does not exceed 30 seconds and the building is equipped throughout with an *automatic sprinkler system* in accordance with Section 903.3.1.1.

6. A sign shall be provided on the door and shall be located above and within 12 inches (305 mm) of the door exit hardware:

- 6.1. For doors that swing in the direction of egress, the sign shall read: PUSH UNTIL ALARM SOUNDS. DOOR CAN BE OPENED IN 15 [30] SECONDS.
- 6.2. For doors that swing in the opposite direction of egress, the sign shall read: PULL UNTIL ALARM SOUNDS. DOOR CAN BE OPENED IN 15 [30] SECONDS.
- 6.3. The sign shall comply with the visual character requirements in ICC A117.1.

Exception: Where *approved*, in Group I occupancies, the installation of a sign is not required where care recipients who because of clinical needs require restraint or containment as part of the function of the treatment area.

7. Emergency lighting shall be provided on the egress side of the door.
8. The delayed egress locking system units shall be *listed* in accordance with UL 294.
9. The delayed egress locking system shall comply with ANSI/BHMA A156.24.

Add new standard(s) follows:

ANSI/BHMA A156.24-2018:

Delayed Egress Locking Systems

Reason:

Delayed egress locking systems are a device, or a combination of devices, arranged to be locked in the direction of egress travel, and are intended to temporarily delay the egress of occupants.

Over the last two cycles of the IBC, delayed egress locking systems have been permitted in new occupancy groups and in some instances more than one delayed egress locking system is permitted in the egress path. These provisions were allowed in light of the increased need for security in E and I occupancies, as well as courtroom buildings.

In addition to the increase in allowed application of delayed egress, since 2012 the Code has evolved to recognize use of a 'delayed egress locking system' which is comprised of not just mechanical but electro-mechanical and electro-magnetic locking systems.

In light of the increased occupancy group allowance and application of more than one delayed egress locking system in the path of egress, requiring compliance to BHMA A156.24 Delayed Egress Locking Systems helps assure these locking systems will function reliably and as intended by the Code.

Cost Impact

The code change proposal will increase the cost of construction .

Requiring delayed egress door locking hardware to comply with ANSI/BHMA A156.24 could be expected to increase the cost of the door hardware. But, recall that delayed egress locking systems are entirely optional (shall be permitted) and are not required by the IBC. Thus, the cost of construction may increase only where delayed egress locking systems are desired.

Also, many delayed egress door locking products are currently on the market today. Currently, the UL online certification directory for "Special Locking Arrangements" contains 23 unique files (23 manufacturers) in category code FWAX - Special Locking Arrangements - with over 100 product models listed for these applications. UL category FWAX includes many products for delayed egress door locking applications.

Analysis: A review of the standard proposed for inclusion in the code, ANSI/BMHA A156.24-2018, with regard to the ICC criteria for referenced standards (Section 3.6 of CP#28) will be posted on the ICC website on or before April 2, 2018.

Internal ID: 2322

E61-18

IBC: 1010.1.9.9, (IFC[BE] 1010.1.9.9)

Proponent: John Williams, Chair, representing Healthcare Committee (AHC@iccsafe.org); Ed Kullik, representing ICC Building Code Action Committee (BCAC@iccsafe.org)

2018 International Building Code

Revise as follows:

1010.1.9.9 Sensor release of electrically locked egress doors. Sensor release of electric locking systems shall be permitted on doors located in the *means of egress* in any occupancy except Group H where installed and operated in accordance with all of the following criteria:

1. The sensor shall be installed on the egress side, arranged to detect an occupant approaching the doors, and shall cause the electric locking system to unlock.
2. The electric locks shall be arranged to unlock by a signal from or loss of power to the sensor.
3. Loss of power to the lock or locking system shall automatically unlock the electric locks.
4. The doors shall be arranged to unlock from a manual unlocking device located 40 inches to 48 inches (1016 mm to 1219 mm) vertically above the floor and within 5 feet (1524 mm) of the secured doors. Ready access shall be provided to the manual unlocking device and the device shall be clearly identified by a sign that reads "PUSH TO EXIT." When operated, the manual unlocking device shall result in direct interruption of power to the electric lock-independent of other electronics and the electric lock shall remain unlocked for not less than 30 seconds.
5. Activation of the building *fire alarm system*, where provided, shall automatically unlock the electric lock, and the electric lock shall remain unlocked until the *fire alarm system* has been reset.
6. Activation of the building *automatic sprinkler system* or fire detection system, where provided, shall automatically unlock the electric lock. The electric lock shall remain unlocked until the *fire alarm system* has been reset.
7. Emergency lighting shall be provided on the egress side of the door.
8. The door locking system units shall be *listed* in accordance with UL 294.

Reason:

The requirement for egress side emergency lighting provides all occupants with minimum egress illumination levels at the door for operation and to read the sign. This proposed requirement is aligned with current delayed egress and controlled egress locking conditions.

This proposal is submitted by the ICC Building Code Action Committee (BCAC). BCAC was established by the ICC Board of Directors in July 2011 to pursue opportunities to improve and enhance assigned International Codes or portions thereof. In 2017 the BCAC has held 3 open meetings. In addition, there were numerous Working Group meetings and conference calls for the current code development cycle, which included members of the committee as well as any interested party to discuss and debate the proposed changes. Related documentation and reports are posted on the BCAC website at: <https://www.iccsafe.org/codes-tech-support/codes/codedevelopment-process/building-code-action-committee-bcac>.

Cost Impact

The code change proposal will not increase or decrease the cost of construction .

If the locking system is installed, added cost may be incurred where emergency lighting is not currently in place.

Internal ID: 588

E62-18

IBC: 1010.1.9.12, (IFC[BE] 1010.1.9.12)

Proponent: John Woestman, Kellen Co., representing Builders Hardware Manufacturers Association (BHMA)
(jwoestman@kellencompany.com)

2018 International Building Code

Revise as follows:

1010.1.9.12 Stairway doors. Interior *stairway means of egress* doors shall be openable from both sides without the use of a key or special knowledge or effort.

Exceptions:

1. *Stairway* discharge doors shall be openable from the egress side and shall only be locked from the opposite side.
2. This section shall not apply to doors arranged in accordance with Section 403.5.3.
3. *Stairway* exit doors are permitted to be locked from the side opposite the egress side, provided that they are openable from the egress side and capable of being unlocked simultaneously without unlatching upon a signal from the *fire command center*, if present, or a signal by emergency personnel from a single location inside the main entrance to the building. The door locking system units shall be listed in accordance with UL 294.
4. *Stairway exit* doors shall be openable from the egress side and shall only be locked from the opposite side in Group B, F, M and S occupancies where the only interior access to the tenant space is from a single *exit stairway* where permitted in Section 1006.3.3.
5. *Stairway exit* doors shall be openable from the egress side and shall only be locked from the opposite side in Group R-2 occupancies where the only interior access to the *dwelling unit* is from a single *exit stairway* where permitted in Section 1006.3.3.

Reason:

Locks which are capable of being unlocked upon a signal from the fire command center (if present) or by a signal by emergency personnel from a single location inside the main entrance to the building would have to be electrified locks controlled by an electrical locking system. Consistent with other electrical locks and locking systems in the means of egress in Sections 1010.1.9.7 through 1010.1.9.10 (controlled egress doors, delayed egress doors, and electrically locked egress doors), it is appropriate to require these locking system units installed on stairway doors to be listed in accordance with UL 294.

Cost Impact

The code change proposal will increase the cost of construction .

Explanation: The same locking devices available and used for the locks in Sections 1010.1.9.7 through 1010.1.9.10 (controlled egress doors, delayed egress doors, and electrically locked egress doors) would likely be used for stairway doors. These locks and locking systems are currently required by the code to be listed in accordance with UL 294 which does add to the cost of the product. However, Exception 3, where the new requirement is proposed is a "shall be permitted" provision, and only where this exception is voluntarily implemented would the potential cost increase be realized.

Internal ID: 2318

E63-18

IBC: 1010.1.10, (IFC[BE] 1010.1.10)

Proponent: Scott Clough, University of Virginia, representing self (sc9xc@virginia.edu)

2018 International Building Code

Revise as follows:

1010.1.10 Panic and fire exit hardware. Swinging doors serving a Group H occupancy and swinging doors serving rooms or spaces with an *occupant load* of 50 or more in a Group A or E occupancy shall not be provided with a latch or lock other than *panic hardware* or *fire exit hardware*.

Exceptions:

1. A main exit of a Group A occupancy shall be permitted to have locking devices in accordance with Section 1010.1.9.4, Item 2.
2. Doors provided with *panic hardware* or *fire exit hardware* and serving a Group A or E occupancy shall be permitted to be electrically locked in accordance with Section 1010.1.9.9 or 1010.1.9.10.

Electrical rooms with equipment rated 1,200 amperes or more ~~and over 6 feet (1829 mm) wide, and~~ that contain overcurrent devices, switching devices or control devices ~~with and have~~ exit or exit access doors, less than 25 feet (7 620 mm) from the nearest edge of the working space in front of the equipment as defined by NFPA 70 shall be equipped with *panic hardware* or *fire exit hardware*. The doors shall swing in the direction of egress travel.

Reason:

This code section was originally intended to correlate with section 110.26(C)(3) of the 2012 edition of the NEC. This section has since been revised and the condition for equipment over 6ft wide has been removed. Additional language was added regarding the distance of the exit door from the working space of the equipment. The IBC should be updated to reflect these changes.

Cost Impact

The code change proposal will not increase or decrease the cost of construction .

Per the current IBC, panic hardware is required when two conditions are met. The proposal revises one of those conditions to align with the NEC. While the NEC may be more restrictive in a small percentage of cases, those rooms would have required panic hardware regardless, in order to comply with the electrical code. Therefore, there is no impact to the cost of construction.

Internal ID: 1462

E64-18

IBC: 1010.1.10, 1010.1.10.1 (New), (IFC[BE] 1010.1.10, 1010.1.10.1 (New))

Proponent: Ed Kullik, Chair, representing ICC Building Code Action Committee (bcac@iccsafe.org)

2018 International Building Code

Revise as follows:

1010.1.10 Panic and fire exit hardware. Swinging doors serving a Group H occupancy and swinging doors serving rooms or spaces with an *occupant load* of 50 or more in a Group A or E occupancy shall not be provided with a latch or lock other than *panic hardware* or *fire exit hardware*.

Exceptions:

1. A main exit of a Group A occupancy shall be permitted to have locking devices in accordance with Section 1010.1.9.4, Item 2.
2. Doors provided with *panic hardware* or *fire exit hardware* and serving a Group A or E occupancy shall be permitted to be electrically locked in accordance with Section 1010.1.9.9 or 1010.1.9.10.

~~Electrical rooms with equipment rated 1,200 amperes or more and over 6 feet (1829 mm) wide, and that contain overcurrent devices, switching devices or control devices with exit or exit access doors, shall be equipped with *panic hardware* or *fire exit hardware*. The doors shall swing in the direction of egress travel.~~

Add new text as follows:

1010.1.10.1 Rooms with electrical equipment. Exit or exit access doors serving transformer vaults, rooms designated for batteries or energy storage systems, or modular data centers shall be equipped with *panic hardware* or *fire exit hardware*. Where rooms contain electrical rooms with equipment rated 800 amperes or more that contain overcurrent devices, switching devices or control devices, shall be equipped with *panic hardware* or *fire exit hardware*. The doors shall swing in the direction of egress travel.

Reason:

The current requirements in the International Building Code are not in alignment with the requirements in NFPA 70, the National Electrical Code. Section 110.26(C)(3) requires where there are exit or exit access doors serving a room with electrical equipment rated 800 amperes or more those doors shall be equipped with listed panic hardware. Equipment rated 1200 amperes or more is used to determine the number and locations of exits or exit access doorways, which is addressed in Section 1006.2.2. Also, NFPA 70 for transformer vaults (in Sections

This proposal is submitted by the ICC Building Code Action Committee (BCAC). BCAC was established by the ICC Board of Directors in July 2011 to pursue opportunities to improve and enhance assigned International Codes or portions thereof. In 2017 the BCAC has held 3 open meetings. In addition, there were numerous Working Group meetings and conference calls for the current code development cycle, which included members of the committee as well as any interested party to discuss and debate the proposed changes. Related documentation and reports are posted on the BCAC website at: <https://www.iccsafe.org/codes-tech-support/codes/codedevelopment-process/building-code-action-committee-bcac>.

Cost Impact

The code change proposal will not increase or decrease the cost of construction .

Chapter 27 of the IBC already requires electrical installations to comply with the provisions of NFPA 70. This proposal aligns the requirements in the IBC with NFPA 70.

Internal ID: 449

E65-18

IBC: 1010.1.10.1, Chapter 35, (IFC[BE] 1010.1.10.1, Chapter 80)

Proponent: John Woestman, Kellen Co., representing Builders Hardware Manufacturers Association (BHMA)
(jwoestman@kellencompany.com)

2018 International Building Code

Revise as follows:

1010.1.10.1 Installation. Where panic or *fire exit hardware* is installed, it shall comply with the following:

1. *Panic hardware* shall be *listed* in accordance with UL 305 and shall comply with ANSI/BHMA A156.3.
2. *Fire exit hardware* shall be *listed* in accordance with UL 10C and UL 305 and shall comply with ANSI/BHMA A156.3.
3. The actuating portion of the releasing device shall extend not less than one-half of the door leaf width.
4. The maximum unlatching force shall not exceed 15 pounds (67 N).

Add new standard(s) follows:

BHMA

Builders Hardware Manufacturers'
Association
355 Lexington Avenue, 15th Floor
New York NY 10017-6603

ANSI/BHMA A156.3-2014:

Exit Devices

Reason:

ANSI/BHMA A156.3 Exit Devices includes all the requirements of UL 305; and additional requirements to help ensure exit devices will perform their intended functions, especially in emergency egress situations. ANSI/BHMA A156.3 has been the voluntary industry performance standard for panic hardware and for fire exit hardware since 1994. A156.3 requires testing which includes additional operational cycles to ensure reliable egress after extended usage; abuse tests, and requirements for outside trim. This proposal updates the IBC to be consistent with requirements in NFPA 101 effective with the 2012 edition.

Cost Impact

The code change proposal will increase the cost of construction .

From an IBC perspective, this proposal adds the requirement for panic hardware and fire exit hardware to also comply with ANSI/BHMA A156.3, which could be expected to increase the cost of construction. But, from a practical perspective, there's very limited panic hardware / fire exit hardware on the market which does not currently comply with ANSI/BHMA A156.3 along with UL 305 (and UL 10C, where required).

Analysis: A review of the standard proposed for inclusion in the code, ANSI/BMHA A156.3-2014, with regard to the ICC criteria for referenced standards (Section 3.6 of CP#28) will be posted on the ICC website on or before April 2, 2018.

Internal ID: 2331

E66-18

IBC: 1011.5.2, (IFC[BE] 1011.5.2)

Proponent: Todd Snider, West Coast Code Consultants (WC3), representing Self (Todd@KimballEng.com)

2018 International Building Code

Revise as follows:

1011.5.2 Riser height and tread depth. *Stair* riser heights shall be 7 inches (178 mm) maximum and 4 inches (102 mm) minimum. The riser height shall be measured vertically between the *nosings* of adjacent treads or between the stairway landing and the adjacent tread. Rectangular tread depths shall be 11 inches (279 mm) minimum measured horizontally between the vertical planes of the foremost projection of adjacent treads and at a right angle to the tread's nosing. *Winder* treads shall have a minimum tread depth of 11 inches (279 mm) between the vertical planes of the foremost projection of adjacent treads at the intersections with the walkline and a minimum tread depth of 10 inches (254 mm) within the clear width of the stair.

Exceptions:

1. *Spiral stairways* in accordance with Section 1011.10.
2. *Stairways* connecting stepped *aisles* to cross *aisles* or concourses shall be permitted to use the riser/tread dimension in Section 1029.14.2.
3. In Group R-3 occupancies; within *dwelling units* in Group R-2 occupancies; and in Group U occupancies that are accessory to a Group R-3 occupancy or accessory to individual *dwelling units* in Group R-2 occupancies; the maximum riser height shall be 7³/₄ inches (197 mm); the minimum tread depth shall be 10 inches (254 mm); the minimum *winder* tread depth at the walkline shall be 10 inches (254 mm); and the minimum *winder* tread depth shall be 6 inches (152 mm). A *nosing* projection not less than ³/₄ inch (19.1 mm) but not more than 1¹/₄ inches (32 mm) shall be provided on *stairways* with solid risers where the tread depth is less than 11 inches (279 mm).
4. See Section 503.1 of the International Existing Building Code for the replacement of existing stairways.
5. In Group I-3 facilities, *stairways* providing access to *guard* towers, observation stations and control rooms, not more than 250 square feet (23 m²) in area, shall be permitted to have a maximum riser height of 8 inches (203 mm) and a minimum tread depth of 9 inches (229 mm).

Reason:

Proposed revision to clarify that a riser is between adjacent treads as well as treads and landings.

Cost Impact

The code change proposal will not increase or decrease the cost of construction .

The change will not affect cost. The purpose is to clarify an existing requirement.

Internal ID: 1287

E67-18

IBC: 1011.5.5, (IFC[BE] 1011.5.5)

Proponent: David Cooper, representing Stairbuilders and Manufacturers Association (SMA) (coderep@stairways.org)

2018 International Building Code

Revise as follows:

1011.5.5 Nosing and riser profile. *Nosings* shall have a curvature or bevel of not less than $\frac{1}{16}$ inch (1.6 mm) but not more than $\frac{9}{16}$ inch (14.3 mm) from the foremost projection of the tread. Risers shall be solid and vertical or sloped under the tread above from the underside of the *nosing* above ~~at an angle not more than 30 degrees (0.52 rad) from the vertical, provided the nosing projection is in accordance with Section 1011.5.5.1.~~

1011.5.5.1 Nosing projection size. The leading edge (nosings) of treads shall project not more than $\frac{1}{4}$ inches (32 mm) beyond the tread below.

Reason:

Figure 1 illustrates the sloped riser angle at the minimum riser height and maximum nosing projection. Figure 2 illustrates the sloped riser angle at the maximum riser height and maximum nosing projection. The current language is confusing because it is impossible to slope the riser anywhere close to 30 degrees without greatly exceeding the maximum nosing projection. The proposed change correlates an appropriate limit and clarifies widely misunderstood code language.

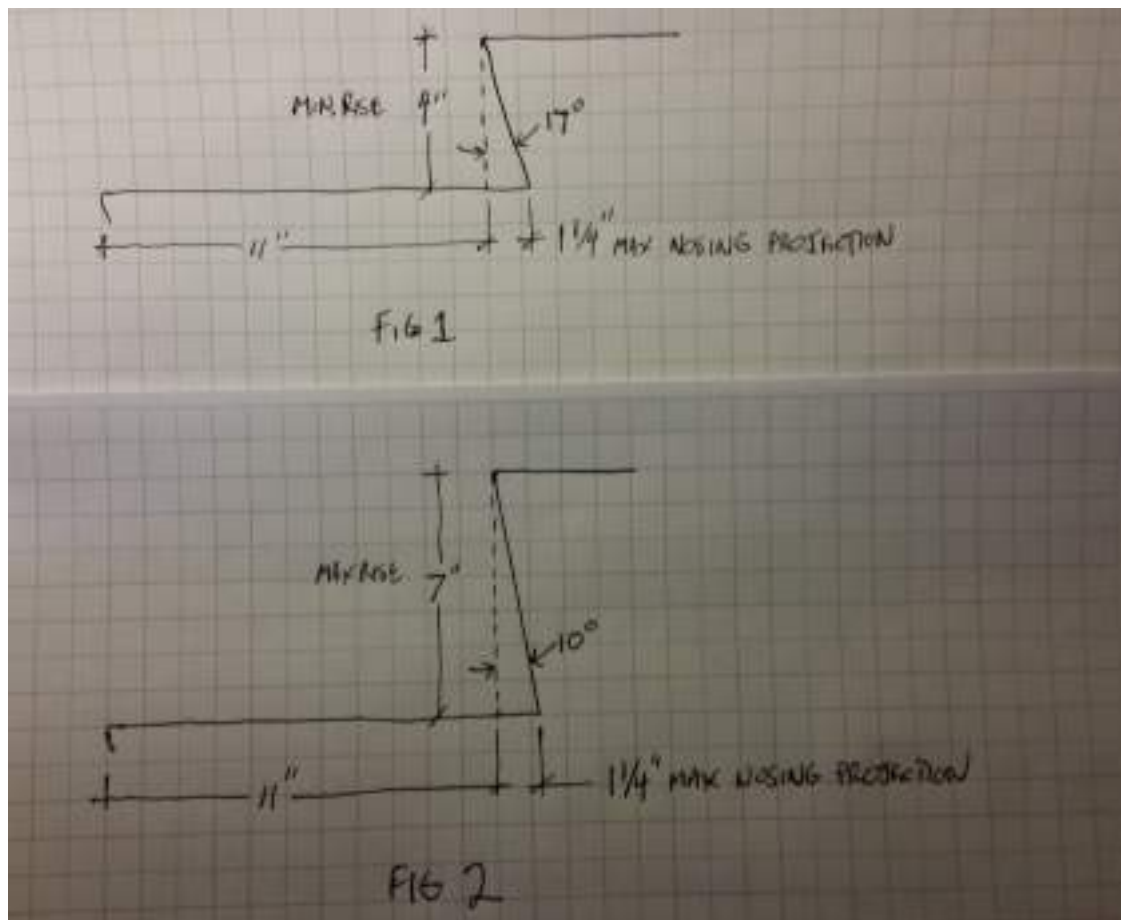

Cost Impact

The code change proposal will not increase or decrease the cost of construction .

This proposal only clarifies the intent of the code and does not change materials or methods.

Internal ID: 1038

E68-18

IBC: 1011.6, (IFC[BE] 1011.6)

Proponent: John Terry, self, representing self (John.Terry@dca.nj.gov)

2018 International Building Code

Revise as follows:

1011.6 Stairway landings. There shall be a floor or landing at the top and bottom of each *stairway*. The width of landings, measured perpendicularly to the direction of travel, shall be not less than the width of *stairways* served. Every landing shall have a minimum depth, measured parallel to the direction of travel, equal to the width of the *stairway* or 48 inches (1219 mm), whichever is less. Doors opening onto a landing shall not reduce the landing to less than one-half the required width. When fully open, the door shall not project more than 7 inches (178 mm) into the required width of a landing. Where wheelchair spaces are required on the *stairway* landing in accordance with Section 1009.6.3, the *wheelchair space* shall not be located in the required width of the landing and doors shall not swing over the *wheelchair spaces*.

Exception: Where *stairways* connect stepped *aisles* to cross *aisles* or concourses, *stairway* landings are not required at the transition between *stairways* and stepped *aisles* constructed in accordance with Section 1029.

Reason:

The degree to which a door may impinge into a corridor and a stairway landing is the same, however, the language in both sections is not. The purpose of this proposed change is to clarify that the limitation on the door projection is into the REQUIRED width, not the provided width. As you can see in the attached plan, technically, the door swings more than 7 inches into the landing, however, it does not impinge on the required width. This will clarify what I believe is the intent of this provision.

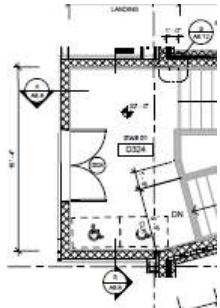

Cost Impact

The code change proposal will not increase or decrease the cost of construction .

The proposed change merely clarifies the intent of the current text and therefore has no impact on cost.

Internal ID: 272

E69-18

IBC: 1011.6, (IFC[BE] 1011.6)

Proponent: David Cooper, Stair Manufacturing and Design Consultants, representing Stairbuilders and Manufacturers Association (SMA) (coderep@stairways.org)

2018 International Building Code

Revise as follows:

1011.6 Stairway landings. There shall be a floor or landing at the top and bottom of each *stairway*. The width of landings, measured perpendicularly to the direction of travel, shall be not less than the width of *stairways* served. Every landing shall have a minimum depth, measured parallel to the direction of travel, equal to the width of the *stairway* or 48 inches (1219 mm), whichever is less. Doors opening onto a landing shall not reduce the landing to less than one-half the required width. When fully open, the door shall not project more than 7 inches (178 mm) into a landing. Where wheelchair spaces are required on the *stairway* landing in accordance with Section 1009.6.3, the *wheelchair space* shall not be located in the required width of the landing and doors shall not swing over the *wheelchair spaces*.

Exception-Exceptions:

1. Where *stairways* connect stepped *aisles* to cross *aisles* or concourses, *stairway* landings are not required at the transition between *stairways* and stepped *aisles* constructed in accordance with Section 1029.
2. At intermediate landings of curved stairways the landing depth shall be measured along the walkline radius between the nosings of the flights adjoining the landing .

Reason:

Similar to a straight run stairway with a landing separating two flights aligned in a straight line the paths of travel on the stairway shown in figure 1 is a continuum. This new exception provides needed specification of where to regulate the landing depth. Due to the tapered shape of the landing similar to the treads of the adjoining flights it makes sense to regulate the depth like the treads at the walklines of the flights. This proposal will provide for consistent interpretation and enforcement.



Cost Impact

The code change proposal will not increase or decrease the cost of construction .

Although the size of these landings are currently open to wide interpretation we feel that this change will not change the cost of construction.

Internal ID: 1040

E70-18

IBC: 1011.6, (IFC[BE] 1011.6)

Proponent: David Cooper, Stair Manufacturing and Design Consultants, representing Stairbuilders and Manufacturers Association (SMA) (coderep@stairways.org)

2018 International Building Code

Revise as follows:

1011.6 Stairway landings. There shall be a floor or landing at the top and bottom of each *stairway*. The width of landings, measured perpendicularly to the direction of travel, shall be not less than the width of *stairways* served. Every landing shall have a minimum depth, measured parallel to the direction of travel, equal to the width of the *stairway* or 48 inches (1219 mm), whichever is less. Doors opening onto a landing shall not reduce the landing to less than one-half the required width. When fully open, the door shall not project more than 7 inches (178 mm) into a landing. Where wheelchair spaces are required on the *stairway* landing in accordance with Section 1009.6.3, the *wheelchair space* shall not be located in the required width of the landing and doors shall not swing over the *wheelchair spaces*.

~~Exception~~ Exceptions:

1. Where *stairways* connect stepped *aisles* to cross *aisles* or concourses, *stairway* landings are not required at the transition between *stairways* and stepped *aisles* constructed in accordance with Section 1029.
2. The landing at stairway turns of 90 degrees (1.57 rad) or more shall not be required to provide a minimum depth in accordance with this section where the corner of the landing on the outside of the turn in plan has been truncated and the area of the landing provided is not less than that described by an arc with a radius equal to the width of the flight served.

Reason:

This proposal simply reiterates the interpretation found in the IBC commentary for more than a decade that has aptly provided guidance to the fact that landings of stairways need not be rectilinear in shape. Truncating the outside corner by rounding or beveling in plan without reduction of the effective width in the path of travel can actually improve compliant use of handrails when continuous handrails are optionally provided at landings by eliminating the need to unnaturally stray from the travel path into the corner to maintain a continuous grip on the handrail.

A proposal with similar intent failed in the last cycle because the text was interpreted to allow a wall niche to be added to a landing to meet the minimum area requirement. This proposal clearly describes the condition under which the corner of a landing may be truncated in plan. In this proposal the turn is described as a turn in the “stairway”. By definition landings and flights of stairs compose stairways and thus the term “stairway turns” is appropriate.

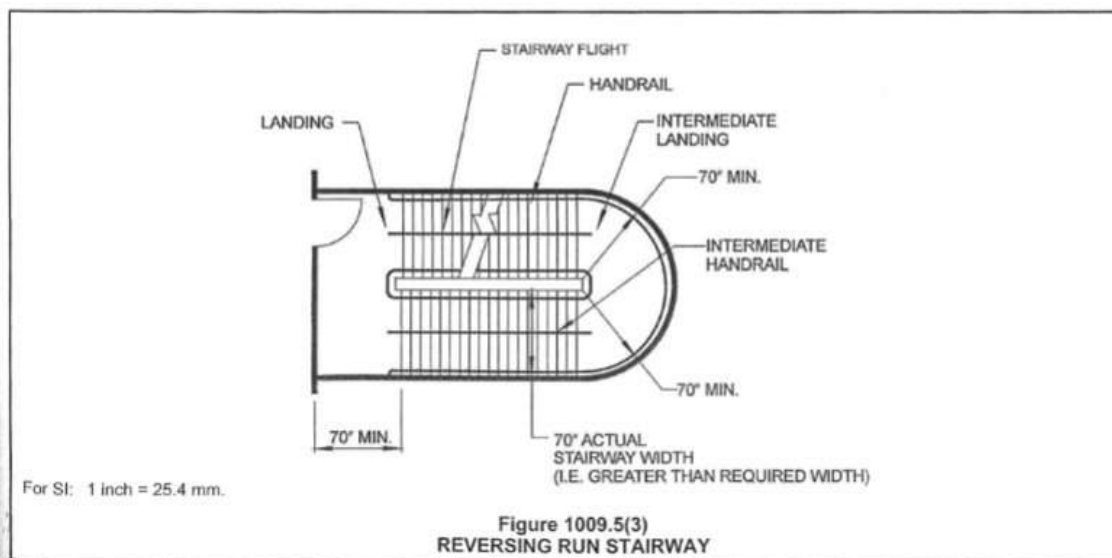

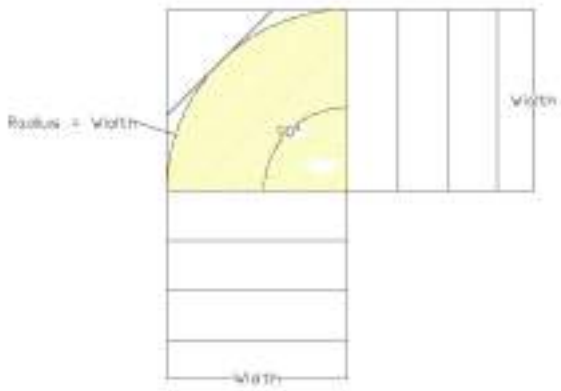

Example of 90 degree stairway turn with minimum landing size.

Cost Impact

The code change proposal will not increase or decrease the cost of construction .

This proposal clarifies the code text to comply with the the most common interpretation and will not increase construction costs.

Internal ID: 1039

E71-18

IBC: 1011.11, (IFC[BE] 1011.11)

Proponent: Don Birdsall, LIFT-U Division of Hogan Mfg., Inc., representing LIFT-U Division of Hogan Mfg., Inc. (donbirdsall@hoganmfg.com)

2018 International Building Code

Revise as follows:

1011.11 Handrails. *Flights of stairways* shall have *handrails* on each side and shall comply with Section 1014. Where glass is used to provide the *handrail*, the *handrail* shall comply with Section 2407.

Exceptions:

1. *Flights of stairways* within *dwelling units* and *flights of spiral stairways* are permitted to have a *handrail* on one side only.
2. Decks, patios and walkways that have a single change in elevation where the landing depth on each side of the change of elevation is greater than what is required for a landing do not require *handrails*.
3. In Group R-3 occupancies, a change in elevation consisting of a single riser at an entrance or egress door does not require *handrails*.
4. Changes in room elevations of three or fewer risers within *dwelling units* and *sleeping units* in Group R-2 and R-3 do not require handrails.
5. Where a platform lift in the park position is accessed by a stairway with two or fewer risers, handrails are not required where handholds are provided that comply with the following:
 - 5.1 Handholds are provided on each side of the top landing.
 - 5.2 Handholds are provided vertically or horizontally with gripping surfaces 34 inches (864mm) high minimum and 42 inches (1066 mm) high maximum above the bottom landing.
 - 5.3 Handholds shall comply with the graspability provisions for handrails and have a length of not less than 4.5 inches (144 mm).

Reason:

The primary intent of this new exception is to provide a safe alternative for a limited situation at platform lifts used to access small raised areas. Because of the movement of the lift, standard set handrails will not work. However, typically these lifts are surrounded by short walls that can serve as handholds for someone to grab to stop a possible fall. This condition frequently exists when a wheelchair lift is installed in a courtroom to provide access to the witness stand and judges' bench. The lift platform is the floor of the Witness Stand. The platform at the entrance to the Witness Stand is commonly parked at a height requiring a step to enter. The Witness Stand is surrounded by millwork low walls. A similar condition can exist in government meeting rooms, churches, and academic buildings.

Section 1011.11 requires two handrails starting at a one riser stairway. The addition of handrails interferes with the vertical travel of the platform lift. The judges' bench and often the witness stand are required to be elevated for safety and court function. A platform lift is required to make these areas accessible by both the ADA and the IBC.

This additional exception provides and describes handholds for this limited situation that assist the person walking up and down the steps and do not interfere with the platform lift operation for persons with mobility issues.





Video of situation: <https://hoganmfg.sharefile.com/d-s7519e8a5a7148c48>

Bibliography:

International Building Code 2015

ASME A18.1 Safety Standard for Platform Lifts and Stairway Chairlifts, 2014 Edition

Cost Impact

The code change proposal will not increase or decrease the cost of construction .

This revision will have minimal to no impact on the cost of the project and will allow access to the Justice System for all users - motion impaired and ambulatory. A barrier removal facilitation change.

Internal ID: 248

E72-18

IBC: 1013.4, 1023.9, 1023.11 (New), (IFC[BE] 1013.4, 1023.9, 1023.11(New))

Proponent: Dawn Anderson, representing self (gonedawning@yahoo.com); Dan Buuck, representing National Association of Home Builders (dbuuck@nahb.org); David Collins, representing the American Institute of Architects (dcollins@preview-group.com); Marsha Mazz, representing U.S. Access Board (mazz@Access-Board.gov); Dominic Marinelli, representing United Spinal Association (DMarinelli@accessibility-services.com)

2018 International Building Code

1013.3 Illumination. Exit signs shall be internally or externally illuminated.

Exception: Tactile signs required by Section 1013.4 need not be provided with illumination.

Revise as follows:

1013.4 Raised character and braille exit signs. ~~A sign stating EXIT in visual characters, raised characters and braille and complying with ICC A117.1 shall be provided adjacent to each door to~~ Where exit signs are provided at an area of refuge, providing direct access to a stairway, an exterior area for assisted rescue, an exit stairway or ramp, an exit passageway and the exit discharge, a sign stating EXIT in visual characters, raised characters and braille and complying with ICC A117.1 shall be provided.

1023.8 Discharge identification. An interior exit stairway and ramp shall not continue below its *level of exit discharge* unless an *approved* barrier is provided at the *level of exit discharge* to prevent persons from unintentionally continuing into levels below. Directional exit signs shall be provided as specified in Section 1013.

1023.9 Stairway identification signs. A sign shall be provided at each floor landing in an *interior exit stairway* and *ramp* connecting more than three stories designating the floor level, the terminus of the top and bottom of the *interior exit stairway* and *ramp* and the identification of the *stairway* or *ramp*. The signage shall state the story of and direction to the *exit discharge*, and the availability of roof access from the *interior exit stairway* and *ramp* for the fire department. The bottom of the sign shall be located 5 feet (1524 mm) minimum above the floor landing in a position that is readily visible when the doors are in the open and closed positions. ~~In addition to the stairway identification sign, a floor-level sign in visual characters, raised characters and braille complying with ICC A117.1 shall be located at each floor-level landing adjacent to the door leading from the interior exit stairway and ramp into the corridor to identify the floor level.~~

1023.9.1 Signage requirements. *Stairway* identification signs shall comply with all of the following requirements:

1. The signs shall be a minimum size of 18 inches (457 mm) by 12 inches (305 mm).
2. The letters designating the identification of the interior exit stairway and *ramp* shall be not less than 1¹/₂ inches (38 mm) in height.
3. The number designating the floor level shall be not less than 5 inches (127 mm) in height and located in the center of the sign.
4. Other lettering and numbers shall be not less than 1 inch (25 mm) in height.
5. Characters and their background shall have a nonglare finish. Characters shall contrast with their background, with either light characters on a dark background or dark characters on a light background.
6. Where signs required by Section 1023.9 are installed in the interior exit *stairways* and *ramps* of buildings subject to Section 1025, the signs shall be made of the same materials as required by Section 1025.4.

1023.10 Elevator lobby identification signs. At landings in interior exit *stairways* where two or more doors lead to the floor level, any door with direct access to an enclosed elevator lobby shall be identified by signage located on the door or directly adjacent to the door stating "Elevator Lobby." Signage shall be in accordance with Section 1023.9.1, Items 4, 5 and 6.

Add new text as follows:

1023.11 Tactile floor-level signs. Where floor level signs are provided in interior exit stairways and ramps, a floor-level sign in visual characters, raised characters and braille complying with ICC A117.1 shall be located at each floor-level landing adjacent to the door leading from the interior exit stairway and ramp into the corridor to identify the floor level.

Reason:

There is a small adjustment to 1013.4 so that it is clear that tactile signage is only required in situations where exit signage is required. The current language could be read to require tactile exit signage at exit doors where exit signage is not required, such as in single exit buildings.

The stairway and lobby identification signs are mostly for fire department personnel so they have information on where they are in the building. The signage requirements in 1023.9.1 result in a large sign (18"x12"). So that everyone in the stairway can see the sign as they evacuate, and the fire department can see the sign when they move into the stairway while occupants are still evacuating, it needs to be clarified that it is the bottom of the sign that needs to be above 5 feet. Current language does not indicate which point of the sign is at 5' and at the same time limit the options for location too much.

For the stairway identification sign to be visible when the doors are in the open and closed position (Section 1023.9) might make the best placement on a wall across from the door, not next the door. This proposal moves the requirement for visual, raised and braille signage at the doorway to a new section so it is more easily understood that this is a separate sign and the information needed. The intent of this tactile sign adjacent to the door provides for information/wayfinding for persons with vision impairments on what floor someone is on as they move to exit the building. The sign at exit discharge in Section 1013.4 would let someone know which door to leave the building (in addition to the barrier in Section 1023.8).

Cost Impact

The code change proposal will not increase or decrease the cost of construction .

These signs are already required by code, this is a clarification of the requirements only.

Internal ID: 541

E73-18

IBC: 1013.4, (IFC[BE] 1013.4)

Proponent: Gene Boecker, representing Code Consultants, Inc. (geneb@codeconsultants.com)

2018 International Building Code

Revise as follows:

1013.4 Raised character and braille exit signs. A sign stating EXIT in visual characters, raised characters and braille and complying with ICC A117.1 shall be provided adjacent to each door to an area of refuge, providing direct access to a stairway, an exterior area for assisted rescue, an *exit stairway* or ramp, an *exit passageway*, a *horizontal exit* and the *exit discharge*.

Reason:

"Horizontal exit" is added to complete the types of locations where tactile exit signs should be provided. A greatly enlarged area of refuge is essentially a horizontal exit. Tactile signage should be placed at all such locations where passage through the opening results in a greater level of safety.

Cost Impact

The code change proposal will increase the cost of construction .

In those cases where a horizontal exit is provided, an additional sign would be required which technically would be an increase in cost.

Internal ID: 931

E74-18

IBC: 1013.6.1, (IFC[BE] 1013.6.1)

Proponent: Daniel E Nichols, MTA Metro-North Railroad, representing MTA Metro-North Railroad (dnichols@mnr.org)

2018 International Building Code

Revise as follows:

1013.6.1 Graphics. Every exit sign and directional exit sign shall have plainly legible letters not less than 6 inches (152 mm) high with the principal strokes of the letters not less than $\frac{3}{4}$ inch (19.1 mm) wide. The word "EXIT" shall have letters having a width not less than 2 inches (51 mm) wide, except the letter "I", and the minimum spacing between letters shall be not less than $\frac{3}{8}$ inch (9.5 mm). Signs larger than the minimum established in this section shall have letter widths, strokes and spacing in proportion to their height.

The word "EXIT" shall be in high contrast with the background and shall be clearly discernible when the means of exit sign illumination is or is not energized. If a chevron directional indicator is provided as part of the exit sign, the construction shall be such that the direction of the chevron directional indicator cannot be readily changed.

Exception: Where approved by the fire code official, alternative font case and dimensions of the word "EXIT" are permitted where based on the use of standardized signage criteria throughout a facility.

Reason:

In locations that utilize signage for both way-finding and emergency egress information, the consistency of lettering increases the readability of the sign. In transit systems, the use of upper- and lower-case is utilized for all information pertaining to exit points, safety information, location description, and other customer communication needs.

In the transportation discipline, the change to upper- and lower-case is being integrated into new roadway guide signs along highways. The recent release of the Manual on Uniform Traffic Control Devices issued by the Federal Highway Administration has incorporated this change to upper- and lower-case for signs that are providing information, like direction to locations. Whereas it not seem a setback to align the EXIT lettering with the remainder of adjacent signage, locations like transit systems utilize more information on a sign than just EXIT to describe how to get to an exit and what the exit actually is.

To prevent inappropriate use of this exception, there are two "gates" that must be satisfied. The first is the approval of the fire code official and the second is the development of a graphic standards design that is consistent throughout the premises.





Cost Impact

The code change proposal will not increase or decrease the cost of construction .

This will not change the cost of construction as this does not change the need for exit signs.

Internal ID: 958

E75-18

IBC: 1014.4, (IFC[BE] 1014.4)

Proponent: Anthony Barnes, representing self (tbarnes@trexcommercial.com)

2018 International Building Code

Revise as follows:

1014.4 Continuity. *Handrail* gripping surfaces shall be continuous, without interruption by newel posts or other obstructions.

Exceptions:

1. *Handrails* within *dwelling units* are permitted to be interrupted by a newel post at a turn or landing.
2. Within a *dwelling unit*, the use of a volute, turnout, starting easing or starting newel is allowed over the lowest tread.
3. Handrail brackets or balusters attached to the bottom surface of the *handrail* that do not project horizontally beyond the sides of the *handrail* within 1½ inches (38 mm) of the bottom of the *handrail* shall not be considered obstructions. For each ½ inch (12.7 mm) of additional *handrail* perimeter dimension above 4 inches (102 mm), the vertical clearance dimension of 1½ inches (38 mm) shall be permitted to be reduced by ⅛ inch (3.2 mm).
4. Where *handrails* are provided along walking surfaces with slopes not steeper than 1:20, the bottoms of the *handrail* gripping surfaces shall be permitted to be obstructed along their entire length where they are integral to crash rails or bumper *guards*.
5. *Handrails* serving stepped *aisles* or ramped *aisles* are permitted to be discontinuous in accordance with Section 1029.16.1.
6. Handrails that are part of demountable guards are permitted gaps of 1 inch (25 mm) maximum in the continuous gripping surface.

Reason:

Demountable or portable equipment is typically built out of 8' maximum length pieces. In order for a ramp or seating riser handrail to be demountable, the handrail needs to be removed easily and quickly. This is best accomplished if it's part of the guard. IBC 1014.4 requires "handrail gripping surfaces to be continuous." This is difficult to achieve without bolting on a continuous handrail to a portable guard. By making the handrail broken at locations typically associated with breaks in guards or platforms/risers, the guard and handrail can be constructed together, ensuring a swifter installation for the end user.

Cost Impact

The code change proposal will decrease the cost of construction .

This change will make for less costly railing system without sacrificing safety.

Internal ID: 2357

E76-18

IBC: 1014.1, 1014.9(New), (IFC[BE] 1014.1, 1014.9(New))

Proponent: Lee Kranz, City of Bellevue, WA, representing Washington Association of Building Officials Technical Code Development Committee (lkranz@bellevuewa.gov)

2018 International Building Code

Revise as follows:

1014.1 Where required. *Handrails* serving *flights of stairways*, ramps, stepped *aisles* and ramped *aisles* shall be adequate in strength and attachment in accordance with Section 1607.8. *Handrails* required for flights of *stairways* by Section 1011.11 shall comply with Sections 1014.2 through ~~1014.9~~ 1014.10. *Handrails* required for *ramps* by Section 1012.8 shall comply with Sections 1014.2 through 1014.8. *Handrails* for stepped *aisles* and ramped *aisles* required by Section 1029.16 shall comply with Sections 1014.2 through 1014.8.

Add new text as follows:

1014.9 Reach range. *Handrails* on the side of stairways shall be located not more than 12 inches (305 mm) laterally outward from the edge of stairway treads.

Revise as follows:

~~**1014.9**~~ **1014.10 Intermediate handrails.** *Stairways* shall have intermediate *handrails* located in such a manner that all portions of the *stairway* minimum width or required capacity are within 30 inches (762 mm) of a handrail. On monumental stairs, *handrails* shall be located along the most direct path of egress travel.

Reason:

Recently I reviewed a stairway design that included a bicycle runnel. Runnels are typically a 15" to 20" wide sloped track that allows a rider to push a bicycle along the side of the stairway while traversing up or down. Currently the code does not limit the maximum distance that a handrail may be located from the edge of the stair treads. The 12" limitation was chosen to allow enough room for runnels while maintaining a comfortable distance for pedestrians to reach the handrail.

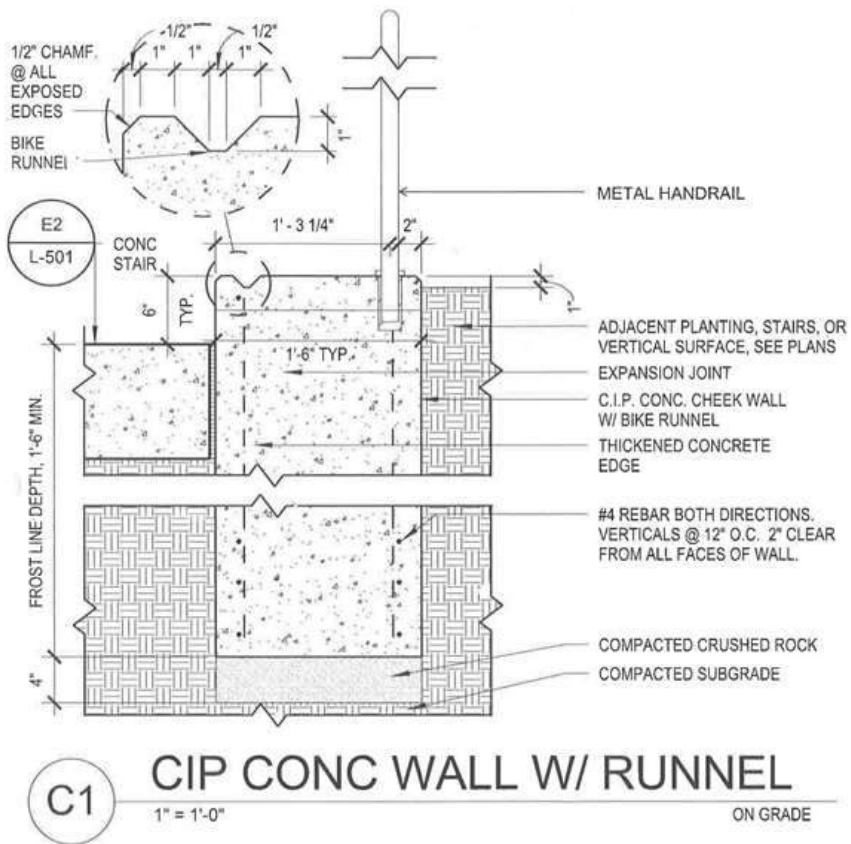

SDR - BIKE RUNNEL AND HANDRAIL EXHIBIT
GGLO, 02/23/2017

Cost Impact

The code change proposal will not increase or decrease the cost of construction .

This change will not affect the cost of construction one way or the other because no additional materials or labor are needed to make the installation.

Internal ID: 90

E77-18

IBC: 1015.2, (IFC[BE] 1015.2)

Proponent: Daniel E Nichols, MTA Metro-North Railroad- New York, NY, representing MTA Metro-North Railroad (dnichols@mnr.org)

2018 International Building Code

Revise as follows:

1015.2 Where required. *Guards* shall be located along open-sided walking surfaces, including *mezzanines*, equipment *platforms*, *aisles*, *stairs*, *ramps* and landings that are located more than 30 inches (762 mm) measured vertically to the floor or grade below at any point within 36 inches (914 mm) horizontally to the edge of the open side. *Guards* shall be adequate in strength and attachment in accordance with Section 1607.8.

Exception: *Guards* are not required for the following locations:

1. On the loading side of loading docks or piers.
2. On the audience side of *stages* and raised *platforms*, including *stairs* leading up to the *stage* and raised *platforms*.
3. On raised *stage* and platform floor areas, such as runways, *ramps* and side *stages* used for entertainment or presentations.
4. At vertical openings in the performance area of *stages* and *platforms*.
5. At elevated walking surfaces appurtenant to *stages* and *platforms* for access to and utilization of special lighting or equipment.
6. Along vehicle service pits not *accessible* to the public.
7. In assembly seating areas at cross *aisles* in accordance with Section 1029.17.2.
8. On the loading side of station platforms on fixed guideway transit or passenger rail systems.

Reason:

This proposal adds an exception that is commonly recognized in the train stations; the absence of a guard on train station platforms where passenger loading occurs. The use of qualifier "on the loading side" is consistent with that of exception #1. The terms "fixed guideway transit systems" and "passenger rail systems" are consistent with the definitions of transportation systems found in NFPA 130.

Cost Impact

The code change proposal will not increase or decrease the cost of construction .

This does not change the cost of construction since this is a clarification of how platforms are treated when applying the guard requirements.

Internal ID: 947

E78-18

IBC: 1015.4, (IFC[BE] 1015.4)

Proponent: Stephen Thomas, Colorado Code Consulting, LLC, representing Colorado Chapter ICC (stthomas@coloradocode.net)

2018 International Building Code

Revise as follows:

1015.4 Opening limitations. Required *guards* shall not have openings that allow passage of a sphere 4 inches (102 mm) in diameter from the walking surface to the required *guard* height.

Exceptions:

1. ~~From a height of 36 inches (914 mm) to 42 inches (1067 mm), *guards* shall not have openings that allow passage of a sphere 4³/₈ inches (111 mm) in diameter.~~
2. The triangular openings at the open sides of a stair, formed by the riser, tread and bottom rail shall not allow passage of a sphere 6 inches (152 mm) in diameter.
3. At elevated walking surfaces for access to and use of electrical, mechanical or plumbing systems or equipment, *guards* shall not have openings that allow passage of a sphere 21 inches (533 mm) in diameter.
4. In areas that are not open to the public within occupancies in Group I-3, F, H or S, and for *alternating tread devices* and ships ladders, *guards* shall not have openings that allow passage of a sphere 21 inches (533 mm) in diameter.
5. In assembly seating areas, *guards* required at the end of *aisles* in accordance with Section 1029.17.4 shall not have openings that allow passage of a sphere 4 inches (102 mm) in diameter up to a height of 26 inches (660 mm). From a height of 26 inches (660 mm) to 42 inches (1067 mm) above the adjacent walking surfaces, *guards* shall not have openings that allow passage of a sphere 8 inches (203 mm) in diameter.

Reason:

This exception is useless. It was changed from 6 inches to 4 3/8 inch just so we didn't need to go to 4 inches. There is no practical purpose to go to 4 3/8 inch at the top of the guard. This exception is never used.

Cost Impact

The code change proposal will not increase or decrease the cost of construction .

No one uses this exception. So, it won't affect the cost of construction either way.

Internal ID: 1068

E79-18

IBC: 1015.4, (IFC[BE] 1015.4)

Proponent: David Cooper, Stair Manufacturing and Design Consultants, representing Stairbuilders and Manufacturers Association (SMA) (coderep@stairways.org)

2018 International Building Code

Revise as follows:

1015.4 Opening limitations. Required *guards* shall not have openings that allow passage of a sphere 4 inches (102 mm) in diameter from the walking surface to the required *guard* height.

Exceptions:

1. From a height of 36 inches (914 mm) to 42 inches (1067 mm), *guards* shall not have openings that allow passage of a sphere $4\frac{3}{8}$ inches (111 mm) in diameter.
2. The triangular openings at the open sides of a stair, formed by the riser, tread and bottom rail shall not allow passage of a sphere 6 inches (152 mm) in diameter.
3. At elevated walking surfaces for access to and use of electrical, mechanical or plumbing systems or equipment, *guards* shall not have openings that allow passage of a sphere 21 inches (533 mm) in diameter.
4. In areas that are not open to the public within occupancies in Group I-3, F, H or S, and for *alternating tread devices* and ships ladders, *guards* shall not have openings that allow passage of a sphere 21 inches (533 mm) in diameter.
5. In assembly seating areas, *guards* required at the end of *aisles* in accordance with Section 1029.17.4 shall not have openings that allow passage of a sphere 4 inches (102 mm) in diameter up to a height of 26 inches (660 mm). From a height of 26 inches (660 mm) to 42 inches (1067 mm) above the adjacent walking surfaces, *guards* shall not have openings that allow passage of a sphere 8 inches (203 mm) in diameter.
6. ~~Within individual dwelling units and sleeping units in Group R-2 and R-3 occupancies, guards~~ Guards on the open sides of *stairs* shall not have openings that allow passage of a sphere $4\frac{3}{8}$ (111 mm) inches in diameter.

Reason:

The $4\frac{3}{8}$ inch sphere rule for guards on stairs has been working well without issue and has proven to be effective in both IBC residential applications and IRC applications, where the susceptible, very- young-children, are far more prevalent than in commercial and public places. A 4" sphere rule requirement for stair guards is an unnecessary and excessive regulation. This change will increase the sphere rule limitation to $4\frac{3}{8}$ inches for all stair guards but will not affect other required guards.

Cost Impact

The code change proposal will decrease the cost of construction .

Fewer balusters or less in-fill material will reduce both material and fabrication costs.

Internal ID: 1041

E80-18

IBC: 1015.8, (IFC[BE] 1015.8)

Proponent: Timothy Pate, Colorado Chapter Code Change Committee, representing Colorado Chapter Code Change Committee (tpate@broomfield.org)

2018 International Building Code

Revise as follows:

1015.8 Window openings. Windows in Group R-2 and R-3 buildings including *dwelling units*, where the ~~top of the sill~~ bottom of an operable window opening is located less than 36 inches above the finished floor and more than 72 inches (1829 mm) above the finished grade or other surface below on the exterior of the building, shall comply with one of the following:

1. Operable windows where the top of the sill of the opening is located more than 75 feet (22 860 mm) above the finished grade or other surface below and that are provided with window fall prevention devices that comply with ASTM F2006.
2. Operable windows where the openings will not allow a 4-inch-diameter (102 mm) sphere to pass through the opening when the window is in its largest opened position.
3. Operable windows where the openings are provided with window fall prevention devices that comply with ASTM F2090.
4. Operable windows that are provided with window opening control devices that comply with Section 1015.8.1.

Reason:

This proposal will change the language on how to measure above the floor for when you need to provide child fall protection. The current language says to measure to the sill and there is not a definition of sill. The sill is typically lower than the bottom of the window opening. This change will modify language to have the measurement to the bottom of the actual opening of the window and will also get language to match what is in section 1030.3 for how to measure for maximum height of egress windows above floor.

Cost Impact

The code change proposal will not increase or decrease the cost of construction .

There will not be any cost impact since the change is just to clarify how to measure height above floor.

Internal ID: 1037

E81-18

IBC: 1015.8, (IFC[BE] 1015.8)

Proponent: Jim Tidwell, Tidwell Code Consulting, representing Self (jimtiddwell@tccfire.com); Jim Graham, Self, representing National Association for Child Window Safety (jgraham@childwindowsafety.org)

2018 International Building Code

Revise as follows:

1015.8 Window openings. Windows in Group R-2 and R-3 buildings including *dwelling units*, where the top of the sill of an operable window opening is located ~~less than 36 inches above the finished floor and~~ more than 72 inches (1829 mm) above the finished grade or other surface below on the exterior of the building, shall comply with one of the following:

1. Operable windows where the top of the sill of the opening is located more than 75 feet (22 860 mm) above the finished grade or other surface below and that are provided with window fall prevention devices that comply with ASTM F2006.
2. Operable windows where the openings will not allow a 4-inch-diameter (102 mm) sphere to pass through the opening when the window is in its largest opened position.
3. Operable windows where the openings are provided with window fall prevention devices that comply with ASTM F2090.
4. Operable windows that are provided with window opening control devices that comply with Section 1015.8.1.

Exception: Windows over counters, plumbing fixtures or doors.

Reason:

This code change is intended to address the ongoing problem of children climbing onto and falling from windows. According to a report published in the *Journal Pediatrics®*, Official Journal of the American Academy of Pediatrics, "From 1990 through 2008, an estimated 98,415 children (95% CI: 82 416– 114 414 children) were treated in US hospital EDs for injuries attributable to a fall from a window, with an average of 5,180 patients (95% CI: 4828 –5531 patients) per year." This report is the most recent, comprehensive study to date on the problem.

There is a viable, inexpensive solution to this problem that has proven effective in the largest city in the United States, New York City. In the mid 1970's, New York City implemented a program they called "Children Can't Fly" in an effort to reduce injuries resulting from window falls. A center piece of that effort was a Local Law requiring window guards in every building with three or more apartments where children under 10 resided. Since then, injuries and deaths from window falls have been dramatically reduced. According to Barbara Barlow, MD, Chief of Pediatric Surgery, Harlem Hospital Center, "The 96% decrease in accidental falls from windows since 1979 demonstrates that the "Children Can't Fly" program in New York City has almost eliminated accidental falls from windows in our hospital population" [quote from report titled "Ten years of experience with falls from a height in children, Barlow B, Niemirska M, Gandhi R, Leblanc W (1983)].

Note that the New York City statute does not stipulate a minimum sill height, as they recognized the fact that children climb on windows; furniture placed near a window can provide a means to climb to the window; and children are inherently curious and will explore areas, such as windows, that have proven dangerous when not properly protected by child window fall protection devices. Using a sill height as a threshold to require fall protection is fallacious because the fall protection is necessary for climbing, exploring children, not just a child who happens to trip and fall near a window.

Also, New York City did not accept limiting devices as a solution. There is another proposal to address this issue separately.

This proposal is simple and straightforward. It removes the reference to a minimum sill height measured inside the room. The current 36" threshold isn't high enough to prevent many children from accidentally falling from a window even if the child is at floor level. For children climbing on the window or adjacent furniture (a significant portion of the problem), any sill height is simply a way around solving the problem, and will not have the desired effect.

Approving this code change will undoubtedly save thousands of children from serious injuries or death at a very low cost.

Cost Impact

The code change proposal will increase the cost of construction .

Increased cost include the addition fall protection for windows not currently required to be equipped with such protection.

Internal ID: 587

E82-18

IBC: 1015.8, 1015.8.1, (IFC[BE] 1015.8, 1015.8.1)

Proponent: Jim Tidwell, Tidwell Code Consulting, representing Self (jimtiddwell@tccfire.com); Jim Graham, Self, representing National Association for Child Window Safety (jgraham@childwindowsafety.org)

2018 International Building Code

Revise as follows:

1015.8 Window openings. Windows in Group R-2 and R-3 buildings including *dwelling units*, where the top of the sill of an operable window opening is located less than 36 inches above the finished floor and more than 72 inches (1829 mm) above the finished grade or other surface below on the exterior of the building, shall comply with one of the following:

- ~~1. Operable windows where the top of the sill of the opening is located more than 75 feet (22 860 mm) above the finished grade or other surface below and that are provided with window fall prevention devices that comply with ASTM F2006.~~
- ~~2.1.~~ Operable windows where the openings will not allow a 4-inch-diameter (102 mm) sphere to pass through the opening when the window is in its largest opened position.
- ~~3.~~ Operable windows where the openings are provided with window fall prevention devices that comply with ASTM F2090.
- ~~4.~~ Operable windows that are provided with window opening control devices that comply with Section ~~1015.8.1.~~
2. Operable windows equipped with corrosion resistant screen capable of withstanding a minimum force of 60 pounds (27 kg) as a concentrated load applied to the center of the screen.
3. Operable windows equipped with barriers with openings that do not allow the passage of a sphere 4 inches (102 mm) in diameter and are capable of withstanding a minimum force of 60 pounds (27 kg) as a concentrated load applied at an location on the barrier.

Delete and substitute as follows:

~~**1015.8.1 Window opening control devices.** Window opening control devices shall comply with ASTM F2090. The window opening control device, after operation to release the control device allowing the window to fully open, shall not reduce the minimum net clear opening area of the window unit to less than the area required by Section 1030.2.~~

1015.8.1 Operation during emergencies. Windows provided for emergency escape and rescue shall comply with Section 1015.8 and Section 1030.2 for operation during emergencies.

Reason:

This code change is intended to address the ongoing problem of children climbing onto and falling from windows. According to a report published in the Journal Pediatrics®, Official Journal of the American Academy of Pediatrics, "From 1990 through 2008, an estimated 98,415 children (95% CI: 82 416- 114 414 children) were treated in US hospital EDs for injuries attributable to a fall from a window, with an average of 5,180 patients (95% CI: 4828 -5531 patients) per year." This report is the most recent, comprehensive study to date on the problem.

There is a viable, inexpensive solution to this problem that has proven effective in the largest city in the United States, New York City. In the mid 1970's, New York City implemented a program they called "Children Can't Fly" in an effort to reduce injuries resulting from window falls. A center piece of that effort was a Local Law requiring window guards in every building with three or more apartments where children under 10 resided. Since then, injuries and deaths from window falls have been dramatically reduced. According to Barbara Barlow, MD, Chief of Pediatric Surgery, Harlem Hospital Center, "The 96% decrease in accidental falls from windows since 1979 demonstrates that the "Children Can't Fly" program in New York City has almost eliminated accidental falls from windows in our hospital population" [quote from report titled "Ten years of experience with falls from a height in children, Barlow B, Niemirska M, Gandhi R, Leblanc W (1983)].

Note that the New York City statute does not stipulate a minimum sill height, as they recognized the fact that children climb on windows; furniture placed near a window can provide a means to climb to the window; and children are inherently curious and will explore areas, such as windows, that have proven dangerous when not properly protected by child window fall protection devices. Using a sill height as a threshold to require fall protection is fallacious because the fall protection is necessary for climbing, exploring children, not just a child who happens to trip and fall near a window.

Also, New York City did not accept limiting devices as a solution. While those devices meet the criteria of ASTM standards, it is widely recognized that the devices are easily and regularly defeated by occupants in need of ventilation, especially during warm weather. When engaged, the limiting devices only allow the window to be opened four inches; however, they are intentionally constructed to allow an adult to easily override the safety feature to fully open the window, thus exposing the child to the fall risk they're intended to address. There is no available data to indicate these devices are having the intended effect, thus the need for a passive physical barrier that allows the window to open to provide necessary ventilation in a space. Allowing these devices in lieu of a physical barrier as described in this proposal places those with the greatest need – the lower socioeconomic strata of our society who depend upon natural ventilation for comfort in warm weather – at the greatest risk.

This proposal is simple and straightforward. It will require all operable windows in residential occupancies to have passive barriers – either window screens or window guards – that meet the ASTM standards for fall protection (60 lbs. concentrated load). It does not recognize limiting devices, as these have shown to be easily overridden, and of limited value.

There is another proposal that addresses the sill height.

Approving this code change will undoubtedly save thousands of children from serious injuries or death at a very low cost.

Cost Impact

The code change proposal will increase the cost of construction .

Potential increase in cost due to the difference in the cost of guards or screens in lieu of vent stops.

Internal ID: 3410

E83-18

IBC: 1015.6, 1015.7 (IFC[BE] 1015.6, 1015.7; IMC[BE]304.11), 3302.4(New)

Proponent: Lauren Bauerschmidt, American Society of Safety Engineers, representing American Society of Safety Engineers (LBauerschmidt@asse.org)

2018 International Building Code

Revise as follows:

1015.6 Mechanical equipment, systems and devices. *Guards* shall be provided where various components that require service are located within 10 feet (3048 mm) of a roof edge or open side of a walking surface and such edge or open side is located more than 30 inches (762 mm) above the floor, roof or grade below. The *guard* shall extend not less than 30 inches (762 mm) beyond each end of such components. The *guard* shall be constructed so as to prevent the passage of a sphere 21 inches (533 mm) in diameter.

Exception: Guards are not required where personal permanent anchorage connectors used in fall arrest anchorage connector devices and restraint systems that comply with ANSI/ASSE Z359.1 are installed. The anchorage connectors shall be inspected and maintained in accordance with ANSI/ASSE Z359.1.

1015.7 Roof access. *Guards* shall be provided where the roof hatch opening is located within 10 feet (3048 mm) of a roof edge or open side of a walking surface and such edge or open side is located more than 30 inches (762 mm) above the floor, roof or grade below. The *guard* shall be constructed so as to prevent the passage of a sphere 21 inches (533 mm) in diameter.

Exception: *Guards* are not required where personal permanent anchorage connectors used in fall arrest anchorage connector devices and restraint systems that comply with ANSI/ASSE Z359.1 are installed. The anchorage connectors shall be inspected and maintained in accordance with ANSI/ASSE Z359.1.

Add new text as follows:

3302.4 Fall protection and fall arrest. Fall protection and fall arrest systems shall comply with applicable requirements of this code and shall comply with ANSI/ASSE Z359.1.

2018 International Mechanical Code

Revise as follows:

[BE] 304.11 Guards. Guards shall be provided where various components that require service and roof hatch openings are located within 10 feet (3048 mm) of a roof edge or open side of a walking surface and such edge or open side is located more than 30 inches (762 mm) above the floor, roof, or grade below. The guard shall extend not less than 30 inches (762 mm) beyond each end of components that require service. The top of the guard shall be located not less than 42 inches (1067 mm) above the elevated surface adjacent to the guard. The guard shall be constructed so as to prevent the passage of a 21-inch-diameter (533 mm) sphere and shall comply with the loading requirements for guards specified in the International Building Code.

Exception: Guards are not required where permanent anchorage connectors used in fall arrest and restraint anchorage connector devices systems that comply with ANSI/ASSE Z359.1 are installed. The anchorage connectors shall be inspected and maintained in accordance with ANSI/ASSE Z359.1.

Reason:

Year over year, falls from heights are the leading cause of death and injury on work sites. In building construction within the scope of the IBC ("construction, alteration, relocation, enlargement, replacement, repair, equipment, use and occupancy, location, maintenance, removal and demolition of every building or structure"), workers are exposed to falls

from heights. The Code must include requirements to either eliminate fall hazards, guard against falls or install fall arrest/restraint systems to prevent injuries and fatalities. The code change proposal incorporates fall protection and fall arrest requirements because the current Code is inadequate.

In response to suggestions ASSE has received, ANSI/ASSE Z359.1-2016 The Fall Protection Code is a comprehensive reference document. The Z359.1-2016 standard states: "The Fall Protection Code encompasses standards for personal fall protection systems that incorporate a full body harness, intended to protect the user against falls from a height either by preventing or arresting free falls. In general, systems that prevent or restrain a fall are preferable to systems that arrest a free fall." By referencing the ANSI/ASSE Z359.1-2016 standard, greater clarification is provided for safe work practices to avoid falls from height causing potential injury or fatality.

Cost Impact

The code change proposal will not increase or decrease the cost of construction .

OSHA 1926.501(a) Safety and Health Regulations for Construction already requires construction to have fall protection. Referencing the ANSI/ASSE Z359.1-2016 standard provides direction to comply with that requirement. Therefore, this code change does not impact the cost of construction.

Internal ID: 1388

E84-18

IBC: 1015.7 (IFC[BE] 1015.7, IMC[BE] 304.11)

Proponent: Guy McMann, representing Colorado Association of Plumbing and Mechanical Officials (CAPMO)
(gcmcmann@jeffco.us)

2018 International Building Code

Revise as follows:

1015.7 Roof access. *Guards* shall be provided where the roof hatch opening is located within 10 feet (3048 mm) of a roof edge or open side of a walking surface and such edge or open side is located more than 30 inches (762 mm) above the floor, roof or grade below. The guard shall extend 30 inches (762mm) beyond each end of the hatch parallel to the roof edge. *The guard* shall be constructed so as to prevent the passage of a sphere 21 inches (533 mm) in diameter.

Exception: *Guards* are not required where personal fall arrest anchorage connector devices that comply with ANSI/ASSE Z 359.1 are installed.

2018 International Mechanical Code

[BE] 304.11 Guards. Guards shall be provided where various components that require service and roof hatch openings are located within 10 feet (3048 mm) of a roof edge or open side of a walking surface and such edge or open side is located more than 30 inches (762 mm) above the floor, roof, or grade below. The guard shall extend not less than 30 inches (762 mm) beyond each end of components that require ~~service.~~ service and each end of the hatch parallel to the roof edge. The top of the guard shall be located not less than 42 inches (1067 mm) above the elevated surface adjacent to the guard. The guard shall be constructed so as to prevent the passage of a 21-inch-diameter (533 mm) sphere and shall comply with the loading requirements for guards specified in the International Building Code.

Exception: Guards are not required where fall arrest/restraint anchorage connector devices that comply with ANSI/ASSE Z 359.1 are installed.

Reason:



The guard needs to be extended beyond the ends of the hatch that is parallel to the roof edge in order to eliminate the tripping hazard that is common when using the hatch. Tools, cords, equipment and other things can easily trip someone up. It's common to use the perimeter wall to fasten a ladder on and position the hatch at the edge of the roof which could seriously injure or kill someone. As can be seen in the photo, it would be easy to trip and fall off the roof even if there is a guard there for the width of the hatch only. This is a true example of life safety.



Cost Impact

The code change proposal will increase the cost of construction .

The cost may increase to provide the added safety feature.

Internal ID: 110

E85-18

IBC: 1016.2, (IFC[BE] 1016.2)

Proponent: Homer Maiel, representing ICC Tri-Chapter (Peninsula, East Bay, Monterey Bay) (hmaiel@gmail.com)

2018 International Building Code

Revise as follows:

1016.2 Egress through intervening spaces. Egress through intervening spaces shall comply with this section.

1. *Exit access* through an enclosed elevator lobby is permitted. ~~Access to~~ Where access to two or more exits or exit access doorways is required in Section 1006.2.1, access to not less than one of the required *exits* shall be provided without travel through the enclosed elevator lobbies required by Section 3006. Where the path of *exit access* travel passes through an enclosed elevator lobby, the level of protection required for the enclosed elevator lobby is not required to be extended to the exit unless direct access to an exit is required by other sections of this code.
2. Egress from a room or space shall not pass through adjoining or intervening rooms or areas, except where such adjoining rooms or areas and the area served are accessory to one or the other, are not a Group H occupancy and provide a discernible path of egress travel to an exit.
Exception: *Means of egress* are not prohibited through adjoining or intervening rooms or spaces in a Group H, S or F occupancy where the adjoining or intervening rooms or spaces are the same or a lesser hazard occupancy group.
3. An *exit access* shall not pass through a room that can be locked to prevent egress.
4. *Means of egress* from *dwelling units* or sleeping areas shall not lead through other sleeping areas, toilet rooms or bathrooms.
5. Egress shall not pass through kitchens, storage rooms, closets or spaces used for similar purposes.

Exceptions:

1. *Means of egress* are not prohibited through a kitchen area serving adjoining rooms constituting part of the same *dwelling unit* or *sleeping unit*.
2. *Means of egress* are not prohibited through stockrooms in Group M occupancies where all of the following are met:
 - 2.1. The stock is of the same hazard classification as that found in the main retail area.
 - 2.2. Not more than 50 percent of the *exit access* is through the stockroom.
 - 2.3. The stockroom is not subject to locking from the egress side.
 - 2.4. There is a demarcated, minimum 44-inch-wide (1118 mm) *aisle* defined by full- or partial-height fixed walls or similar construction that will maintain the required width and lead directly from the retail area to the exit without obstructions.

Reason:

This proposal is clarifying that when access to two or more exits are required, one access can go through elevator lobby. Where only one access, due to low occupant load, is required then that access can go through elevator lobby.

Cost Impact

The code change proposal will not increase or decrease the cost of construction .

This is a clarification for single exit spaces and will not change construction requirements.

Internal ID: 1520

E86-18

IBC: 1017.3, (IFC[BE] 1017.3)

Proponent: John Terry, self, representing self (John.Terry@dca.nj.gov)

2018 International Building Code

Revise as follows:

SECTION 1017 EXIT ACCESS TRAVEL DISTANCE

1017.3 Measurement. *Exit access* travel distance shall be measured from the most remote point of each room, area or space along the natural and unobstructed path of horizontal and vertical egress travel to the entrance to an exit. Where more than one means of egress is required, exit access travel distance shall be measured to the nearest exit.

Exception: In open parking garages, *exit access* travel distance is permitted to be measured to the closest riser of an *exit access stairway* or the closest slope of an *exit access ramp*.

Reason:

The text of this section is too subtle where it is stated that travel distance is measured to “an” exit. The added language makes clear the intent of the requirement.

Cost Impact

The code change proposal will not increase or decrease the cost of construction .

The proposed change merely clarifies the intent of the current text and therefore has no impact on cost.

Internal ID: 271

E87-18

IBC: 1019.2, 1019.3, 1019.4, (IFC[BE] 1019.2, 1019.3, 1019.4)

Proponent: Gregory Keith, representing The Boeing Company (grkeith@mac.com)

2018 International Building Code

Add new text as follows:

1019.2 Construction. Where exit access stairways and ramps are required to be enclosed by other provisions of this section, they shall be constructed in accordance with the provisions of Section 1023.2. Stairway openings, penetrations and ventilation shall be in accordance with the provisions of Sections 1023.4, 1023.5 and 1023.6, respectively.

Revise as follows:

~~1019.2~~**1019.3 All occupancies.** *Exit access stairways and ramps* that serve floor levels within a single story are not required to be enclosed.

~~1019.3~~**1019.4 Occupancies other than Groups I-2 and I-3.** In other than Group I-2 and I-3 occupancies, floor openings containing *exit access stairways or ramps* that do not comply with one of the conditions *listed* in this section shall be enclosed ~~with a shaft enclosure constructed in accordance with Section 713.~~

1. *Exit access stairways and ramps* that serve or atmospherically communicate between only two stories. Such interconnected stories shall not be open to other stories.
2. In Group R-1, R-2 or R-3 occupancies, *exit access stairways and ramps* connecting four stories or less serving and contained within an individual *dwelling unit or sleeping unit or live/work unit*.
3. *Exit access stairways* serving and contained within a Group R-3 congregate residence or a Group R-4 facility are not required to be enclosed.
4. *Exit access stairways and ramps* in buildings equipped throughout with an *automatic sprinkler system* in accordance with Section 903.3.1.1, where the area of the vertical opening between stories does not exceed twice the horizontal projected area of the *stairway or ramp* and the opening is protected by a draft curtain and closely spaced sprinklers in accordance with NFPA 13. In other than Group B and M occupancies, this provision is limited to openings that do not connect more than four stories.
5. *Exit access stairways and ramps* within an *atrium* complying with the provisions of Section 404.
6. *Exit access stairways and ramps* in *open parking garages* that serve only the parking garage.
7. *Exit access stairwaysrampssmoke-protected or open-air assembly seatingexit access* travel distance requirements of Section 1029.7.
8. *Exit access stairwaysramps* gallery or press box and the main assembly floor in occupancies such as theaters, *places of religious worship*, auditoriums and sports facilities.

~~1019.4~~**1019.5 Group I-2 and I-3 occupancies.** In Group I-2 and I-3 occupancies, floor openings between stories containing *exit access stairways or ramps* are required to be enclosed ~~with a shaft enclosure constructed in accordance with Section 713.~~

Exception: In Group I-3 occupancies, *exit access stairways or ramps* constructed in accordance with Section 408 are not required to be enclosed.

Reason:

Currently, where exit access stairways and ramps are required to be enclosed by Sections 1019.3 or 1019.4, those sections state that they should be enclosed with a shaft enclosure in accordance with Section 713. This proposal deletes those references and replaces them with a new construction provision in Section 1019.2 that requires that enclosed exit access stairways comply with Section 1023 construction, opening protection, penetration protection and ventilation requirements as for interior exit stairways.

The current shaft enclosure construction requirement has legacy origins for convenience stairways. Exit access stairways, however, are formal means of egress components and their construction should be consistent with occupant safety needs. The apparent upgrade is less impactful than might be thought. The construction requirements for shaft

enclosures and interior exit stairways are virtually identical. The primary difference occurs with opening and penetration protection requirements. Obviously, interior exit stairway opening and penetration provisions are better suited to protect occupants in the means of egress as opposed to present utility protection concerns.

The original purpose of the exit access stairway concept was to allow for unenclosed, non-rated interior stairways within building spaces so as to allow for occupant circulation and access to exits at other building levels. Where Section 1019.3 conditions are exceeded, such exit access stairways must be enclosed. As occupants enter an enclosed stairway, they have an expectation that those stairways will provide a relatively tenable environment during egress. To meet occupant expectations and increase fire and life safety, shaft enclosure construction requirements are proposed to be replaced by interior exit stairway construction requirements. Approval of this proposal will increase occupant safety based on current means of egress philosophy.

Cost Impact

The code change proposal will decrease the cost of construction .

Shaft enclosure and interior exit stairway construction requirements are virtually identical. Interior exit stairway opening, penetration and ventilation requirements, however, are much more restrictive. Due to the limited types and numbers of such breeches, construction costs should decrease. Practically speaking, these are the types of protections that would logically be used in an enclosed stairway; and therefore, would likely not impact the cost of construction.

Internal ID: 1568

E88-18

IBC: 1019.3, (IFC[BE]1019.3)

Proponent: Lee Kranz, City of Bellevue, WA, representing Washington Association of Building Officials Technical Code Development Committee (lkranz@bellevuewa.gov)

2018 International Building Code

Revise as follows:

1019.3 Occupancies other than Groups I-2 and I-3. In other than Group I-2 and I-3 occupancies, floor openings containing *exit access stairways* or *ramps* ~~that do not comply with one of the conditions listed in this section~~ shall be enclosed with a shaft enclosure constructed in accordance with Section 713.

Exceptions:

1. *Exit access stairways* and *ramps* that serve or atmospherically communicate between only two stories. Such interconnected stories shall not be open to other stories.
2. In Group R-1, R-2 or R-3 occupancies, *exit access stairways* and *ramps* connecting four stories or less serving and contained within an individual *dwelling unit* or *sleeping unit* or *live/work unit*.
3. *Exit access stairways* serving and contained within a Group R-3 congregate residence or a Group R-4 facility are not required to be enclosed.
4. *Exit access stairways* and *ramps* in buildings equipped throughout with an *automatic sprinkler system* in accordance with Section 903.3.1.1, where the area of the vertical opening between stories does not exceed twice the horizontal projected area of the *stairway* or *ramp* and the opening is protected by a draft curtain and closely spaced sprinklers in accordance with NFPA 13. In other than Group B and M occupancies, this provision is limited to openings that do not connect more than four stories.
5. *Exit access stairways* and *ramps* within an *atrium* complying with the provisions of Section 404.
6. *Exit access stairways* and *ramps* in *open parking garages* that serve only the parking garage.
7. *Exit access stairways* and *ramps* serving *smoke-protected* or *open-air assembly seating* complying with the *exit access* travel distance requirements of Section 1029.7.
8. *Exit access stairways* and *ramps* between the balcony, gallery or press box and the main assembly floor in occupancies such as theaters, *places of religious worship*, auditoriums and sports facilities.

Reason:

The charging language in this section is difficult to interpret. The eight items listed are essentially exceptions to the requirement for the stair or ramp to be in an enclosed shaft so why not say it that way?

Cost Impact

The code change proposal will not increase or decrease the cost of construction .

Clarrification only. This change will not impact the cost of construction.

Internal ID: 305

E89-18

IBC: 1019.3, (IFC[BE] 1019.3)

Proponent: Lee Kranz, representing Washington Association of Building Officials Technical Code Development Committee (lkranz@bellevuewa.gov)

2018 International Building Code

Revise as follows:

1019.3 Occupancies other than Groups I-2 and I-3. In other than Group I-2 and I-3 occupancies, floor openings containing exit access stairways or ramps that do not comply with one of the conditions listed in this section shall be enclosed with a shaft enclosure constructed in accordance with Section 713.

1. Exit access stairways and ramps that serve or atmospherically communicate between only two adjacent stories. Such interconnected stories shall not be open to other stories.
2. In Group R-1, R-2 or R-3 occupancies, exit access stairways and ramps connecting four stories or less serving and contained within an individual dwelling unit or sleeping unit or live/work unit.
3. Exit access stairways serving and contained within a Group R-3 congregate residence or a Group R-4 facility are not required to be enclosed.
4. Exit access stairways and ramps in buildings equipped throughout with an automatic sprinkler system in accordance with Section 903.3.1.1, where the area of the vertical opening between stories does not exceed twice the horizontal projected area of the stairway or ramp and the opening is protected by a draft curtain and closely spaced sprinklers in accordance with NFPA 13. In other than Group B and M occupancies, this provision is limited to openings that do not connect more than four stories.
5. Exit access stairways and ramps within an atrium complying with the provisions of Section 404.
6. Exit access stairways and ramps in open parking garages that serve only the parking garage.
7. Exit access stairways and ramps serving smoke-protected or open-air assembly seating complying with the exit access travel distance requirements of Section 1029.7.
8. Exit access stairways and ramps between the balcony, gallery or press box and the main assembly floor in occupancies such as theaters, places of religious worship, auditoriums and sports facilities.

Reason:

Under the current code it is possible to "skip" a story with the stair shaft which could create a path for smoke migration from, for example, the 1st story to the 3rd or 4th story. This change would require that the stories be adjacent to each other in order for the stairway to be open.

Cost Impact

The code change proposal will not increase or decrease the cost of construction .

Clarrification only; no cost impact.

Internal ID: 94

E90-18

IBC: TABLE 1020.2, (IFC[BE] TABLE 1020.2)

Proponent: Homer Maiel, representing ICC Tri-Chapter (Peninsula, East Bay, Monterey Bay) (hmaiel@gmail.com)

2018 International Building Code

Revise as follows:

**TABLE 1020.2
MINIMUM CORRIDOR WIDTH**

OCCUPANCY	MINIMUM WIDTH (inches)
Any facility not <i>listed</i> in this table	44
Access to and utilization of mechanical, plumbing or electrical systems or equipment	24 36
With an <i>occupant load</i> of less than 50	36
Within a <i>dwelling unit</i>	36
In Group E with a <i>corridor</i> having an <i>occupant load</i> of 100 or more	72
In corridors and areas serving stretcher traffic in ambulatory care facilities	72
Group I-2 in areas where required for bed movement	96

For SI: 1 inch = 25.4 mm.

Reason:

In order to be consistent with Section 306.2 of IMC and Section 1010.1.1 of IBC, this change is warranted.

Cost Impact

The code change proposal will increase the cost of construction .

The change of corridor and door widths will increase the cost of construction.

Internal ID: 1523

E91-18

IBC: 1020.4, (IFC[BE] 1020.4)

Proponent: John Mengedoht, representing NBBJ (jmengedoht@nbbj.com)

2018 International Building Code

Revise as follows:

1020.4 Dead ends. Where more than one exit or *exit access doorway* is required, the *exit access* shall be arranged such that dead-end *corridors* do not exceed 20 feet (6096 mm) in length.

Exceptions:

1. In in Group I-3, Condition 2, 3 or 4, occupancies, the dead end in a *corridor* shall not exceed 50 feet (15 240 mm).
2. In occupancies in Groups B, E, F, I-1, M, R-1, R-2, S and U, where the building is equipped throughout with an *automatic sprinkler system* in accordance with Section 903.3.1.1, the length of the dead-end *corridors* shall not exceed 50 feet (15 240 mm).
3. A dead-end *corridor* shall not be limited in length where the length of the dead-end *corridor* is less than 2.5 times the least width of the dead-end corridor.
4. In Group I-2, Condition 2 occupancies, the length of dead end corridors that do not serve patient rooms or patient treatment spaces shall not exceed 30 feet (9144 mm).

Reason:

The 20 foot dead end corridor limit makes sense in hospitals where patients might not be easily or rapidly moved. However, 20 feet does not appear to make sense for for non-patient areas such as staff areas or small waiting areas for visitors which are functionally similar to Group B spaces. Hospitals receiving Medicare or Medicaid payments (nearly all) are subject to the federal Centers for Medicare and Medicaid Services (CMS), which requires compliance with the 2012 NFPA 101. The NFPA 101 requires a maximum of 30 foot dead end corridors in "health care" occupancies (hospitals) so this proposal will align with NFPA 101 in this regard.

At the same time, the NFPA 101 requires a 2 hour separation between health care (hospital) occupancies and other occupancies. Therefore, designating areas of a hospital as Group B in order to achieve longer dead end corridors is not cost-effective due to the added cost of the 2 hour rated occupancy separation.

Bibliography:

2012 NFPA 101, Chapter 18 New Health Care Occupancies, Section 18.2.5.2: Dead-end corridors shall not exceed 30 ft (9.1 m).

2012 NFPA 101, Chapter 19 Existing Health Care Occupancies, Section 19.2.5.2: Existing dead-end corridors not exceeding 30 ft (9.1 m) shall be permitted.

2012 NFPA 101, Chapter 18 New Health Care Occupancies, Section 18.1.3.3: Sections of health care facilities shall be permitted to be classified as other occupancies, provided that... they are separated from areas of health care occupancies by construction having a minimum 2 hour fire resistance rating in accordance with Chapter 8.

2012 NFPA 101, Chapter 18 Existing Health Care Occupancies, Section 19.1.3.3: Sections of health care facilities shall be permitted to be classified as other occupancies, provided that... they are separated from areas of health care occupancies by construction having a minimum 2 hour fire resistance rating in accordance with Chapter 8.

Cost Impact

The code change proposal will not increase or decrease the cost of construction .

Extending dead end corridors to a maximum of 30 feet will not impact the cost of construction but it will provide greater flexibility in the design of hospitals.

Internal ID: 1310

E92-18

IBC: 1020.5 (IFC[BE] 1020.5)

Proponent: John Williams, Chair, representing Healthcare Committee (AHC@iccsafe.org)

2018 International Building Code

Revise as follows:

1020.5 Air movement in corridors. Corridors shall not serve as supply, return, exhaust, relief or ventilation air ducts.

Exceptions:

1. Use of a *corridor* as a source of makeup air for exhaust systems in rooms that open directly onto such corridors, including toilet rooms, bathrooms, dressing rooms, smoking lounges and janitor closets, shall be permitted, provided that each such *corridor* is directly supplied with outdoor air at a rate greater than the rate of makeup air taken from the corridor.
2. Where located within a *dwelling unit*, the use of *corridors* for conveying return air shall not be prohibited.
3. Where located within tenant spaces of 1,000 square feet (93 m²) or less in area, utilization of *corridors* for conveying return air is permitted.
4. ~~Incidental air movement from pressurized rooms within health care facilities, provided that the corridor is not the primary source of supply or return to the room.~~ Transfer air movement required to maintain pressurization difference within health care facilities in accordance with Section 407.1 of the International Mechanical Code.

Reason:

This is a clarification for when the corridor can be used for air movement. ASHREA 170 was added in IMC which clarifies which rooms are pressurized. This makes that connection in the codes. This is intended to cover transfer air for both positive and negative charged rooms. We thought 'transfer' was a more descriptive word for the air movement.

This proposal is submitted by the ICC Committee on Healthcare (CHC). The CHC was established by the ICC Board to evaluate and assess contemporary code issues relating to healthcare facilities. This is a joint effort between ICC and the American Society for Healthcare Engineering (ASHE), a subsidiary of the American Hospital Association, to eliminate duplication and conflicts in healthcare regulation. In 2017 the CHC held 2 open meetings and numerous conference calls, which included members of the committees as well as any interested parties, to discuss and debate the proposed changes. Information on the CHC, including: meeting agendas; minutes; reports; resource documents; presentations; and all other materials developed in conjunction with the CHC effort can be downloaded from the CHC website at: <https://www.iccsafe.org/codes-tech-support/cs/icc-committee-on-healthcare/>.

Cost Impact

The code change proposal will not increase or decrease the cost of construction .

ASHREA 170 is already required in the IMC for pressurized rooms, so there are no changes to construction requirements.

Internal ID: 708

E93-18

IBC: 1021.4, (IFC[BE] 1021.4)

Proponent: Lawrence Cousin, representing Self (larrycivic@hotmail.com)

2018 International Building Code

Revise as follows:

1021.4 Location. Exterior egress balconies shall have a minimum *fire separation distance* of 10 feet (3048 mm) measured at right angles from the exterior edge of the egress balcony to the following:

1. Adjacent *lot lines*.
2. Other portions of the building.
3. Other buildings and equipment yards on the same lot unless the adjacent building *exterior walls* and openings are protected in accordance with Section 705 based on fire separation distance.

For the purposes of this section, other portions of the building shall be treated as separate buildings.

Reason:

This is necessary to address the ambiguity of the required minimum separation distance (clearance) between a building and equipment yard on the same lot. Equipment yard is not a building but the slab on which the equipment stands is a structure. Case in point is trying to establish the minimum required distance between a school building and equipment yard/chiller. Just need clarity in the code.

Cost Impact

The code change proposal will not increase or decrease the cost of construction .

The cost will not change because this proposal addresses separation distance from structure to structure. Elsewhere in the code describes construction based on separation distance.

Internal ID: 1380

E94-18

IBC: 1023.2, (IFC[BE] 1023.2)

Proponent: Stephen Thomas, representing Colorado Chapter ICC (sthomas@coloradocode.net)

2018 International Building Code

Revise as follows:

1023.2 Construction. Enclosures for interior exit *stairways* and *ramps* shall be constructed as *fire barriers* in accordance with Section 707 or *horizontal assemblies* constructed in accordance with Section 711, or both. *Interior exit stairway* and *ramp* enclosures shall have a fire-resistance rating of not less than 2 hours where connecting four stories or more and not less than 1 hour where connecting less than four stories. The number of stories connected by the interior exit *stairways* or *ramps* shall include any *basements*, but not any *mezzanines*. Enclosures for ~~interior-interior~~ exit stairways and ramps shall have a fire-resistance rating not less than the floor assembly penetrated, but need not exceed 2 hours.

Exceptions:

1. *Interior exit stairways* and *ramps* in Group I-3 occupancies in accordance with the provisions of Section 408.3.8.
2. *Interior exit stairways* within an *atrium* enclosed in accordance with Section 404.6.

Reason:

This change is editorial in nature. We are only trying to make the last sentence consistent with the first sentence. The enclosure is what is required to be fire-resistant rated, not the stairway itself.

Cost Impact

The code change proposal will not increase or decrease the cost of construction .

The change is editorial in nature.

Internal ID: 237

E95-18

IBC: 1023.2, (IFC[BE] 1023.2)

Proponent: Homer Maiel, representing ICC Tri-Chapter (Peninsula, East Bay, Monterey Bay) (hmaiel@gmail.com)

2018 International Building Code

Revise as follows:

1023.2 Construction. Enclosures for interior exit *stairways* and *ramps* shall be constructed as *fire barriers* in accordance with Section 707 or *horizontal assemblies* constructed in accordance with Section 711, or both. *Interior exit stairway* and *ramp* enclosures shall have a fire-resistance rating of not less than 2 hours where connecting four stories or more and not less than 1 hour where connecting less than four stories. The number of stories connected by the interior exit *stairways* or *ramps* shall include any *basements*, but not any *mezzanines*. *Interior exit stairways* and *ramps enclosures* shall have a fire-resistance rating not less than the floor assembly penetrated, but need not exceed 2 hours.

Exceptions:

1. *Interior exit stairways* and *ramps* in Group I-3 occupancies in accordance with the provisions of Section 408.3.8.
2. *Interior exit stairways* within an *atrium* enclosed in accordance with Section 404.6.

Reason:

This is merely a clarification to the section.

Cost Impact

The code change proposal will not increase or decrease the cost of construction .

This is an editorial correction with not changes for construction requirements.

Internal ID: 1521

E96-18

IBC: 1023.2, (IFC[BE] 1023.2)

Proponent: Gregory Keith, representing The Boeing Company (grkeith@mac.com); Douglas Evans, representing DHE FPE LLC (dhefpe@gmail.com)

2018 International Building Code

Revise as follows:

1023.2 Construction. Enclosures for interior exit *stairways* and *ramps* shall be constructed as *fire barriers* in accordance with Section 707 or *horizontal assemblies* constructed in accordance with Section 711, or both. *Interior exit stairway* and *ramp* enclosures shall have a fire-resistance rating of not less than 2 hours where connecting four stories or more and not less than 1 hour where connecting less than four stories. The number of stories connected by the interior exit *stairways* or *ramps* shall include any *basements*, but not any *mezzanines*. *Interior exit stairways* and *ramps* shall have a fire-resistance rating not less than the floor assembly penetrated, but need not exceed 2 hours.

Exceptions-Exception:

1. *Interior exit stairways* and *ramps* in Group I-3 occupancies in accordance with the provisions of Section 408.3.8.
2. ~~*Interior exit stairways* within an atrium enclosed in accordance with Section 404.6.~~

Reason:

Exception 2 to interior exit stairway enclosure construction within an atrium space was introduced in the 2015 Edition of the IBC. The proponent's published reason statement contended that the inherent one-hour atrium enclosure protection and required smoke control was equivalent to a one-hour interior exit stairway enclosure. Although equivalency to a one-hour enclosure can be debated, exit stairways serving four or more stories are required to be of 2-hour fire resistance-rated construction. The atrium enclosure protection is also exempted on three levels (404.6 Exception 3), which allows these stairs open to those levels.

This provision is also philosophically flawed on many levels. Interior exit stairway enclosures are to be used for no purpose other than as a means of egress. Opening and penetration protection requirements are intended to limit exposure of the enclosure.

The plural in Exception 2 (stairways) allows all required exits to be through the atrium. The current exception allows occupants unlimited egress travel distance down unenclosed stairways even if the stairs are within the smoke plume. Furthermore, compliance with Section 909 is typically reliant on fans, dampers, secondary power supplies and the ever changing fuel loading on the atrium floor. In high-rise buildings, such stairways are required to be within smokeproof enclosures.

Allowing unlimited travel distance on an unenclosed stairway is technically and philosophically inconsistent with the exit access travel distance limitations stated at Section 404.9. Those provisions allow for a maximum of 200 feet of travel at other than the level of exit discharge. The IBC Code and Commentary, Volume I states, "Since smoke is being drawn into the atrium, the time allotted to reach an exit through the atrium is limited." It would seem logical that that same thinking would apply to an unenclosed interior exit stairway.

Additionally, Section 905.4 requires a standpipe hose connection for each story in every required interior exit stairway since these enclosures provide a protected space for fire department operations. Obviously, there is no passive standpipe hose connection protection in an unenclosed interior exit stairway.

Traditionally, exit access stairways within atrium spaces have been allowed to be unenclosed (Section 1019.3, Condition 5). However, exit access travel distance limitations in Section 1017.2 apply. In fact, Table 1017.2 Footnote a, references Section 404.9 travel distance limitations through an atrium space. This minimally creates confusion, if not a contradiction.

This proposal restores the original ICC Code Technology Committee philosophy that interior exit stairways always be enclosed with no exceptions. Removal of the current exception ensures a protected path of means of egress travel for building occupants between the exit access and exit discharge portions of the means of egress system.

Cost Impact

The code change proposal will increase the cost of construction .

Approval of this proposal will increase the cost of construction only in buildings having an atrium where an unenclosed interior exit stairway is desired. If the building otherwise has the required number of exits, such a stairway would be

regarded as an exit access stairway and there would be no cost impact.

Internal ID: 1479

E97-18

IBC: 1023.4, (IFC[BE] 1023.4)

Proponent: Keith Flanders, Cosentini Associates, representing self (kflanders@cosentini.com)

THIS CODE CHANGE WILL BE HEARD BY THE FIRE SAFETY CODE DEVELOPMENT COMMITTEE. SEE THE TENTATIVE HEARING ORDER FOR THIS COMMITTEE.

2018 International Building Code

Revise as follows:

1023.4 Openings. *Interior exit stairway and ramp* opening protectives shall be in accordance with the requirements of Section 716.

Openings in *interior exit stairways* and *ramps* other than unprotected exterior openings shall be limited to those required for *exit access* to the enclosure from normally occupied spaces and for egress from the enclosure.

Elevators shall not open into *interior exit stairways* and ramps.

Exception:Openings are permitted from a normally unoccupied space where the interior exit stairway or ramp is pressurized as a smokeproof enclosure in accordance with Section 909.20.6.

Reason:

A pressurized smokeproof enclosure requires a smoke detector be provided at the entrance to the interior exit stairway or ramp. As such, the concern of a fire developing unnoticed is mitigated by the presence of a smoke detector which is connected to building fire alarm system. This allows for early notification of building occupants, quick response by the fire department, and activation of the pressurization system to protect the stair from smoke infiltration.

Often times, a mechanical penthouse or fire pump room is directly accessed from a stair. However, these are considered normally unoccupied spaces and therefore a vestibule must be provide between the stair and the mechanical space to alleviate these door opening provisions from such a space. However, when the stair is pressurized, the additional requirements alleviate the concerns of openings from a normally unoccupied space. Accordingly it is reasonable to have the normally unoccupied space open into the stair without requiring a vestibule to separate the two spaces.

Cost Impact

The code change proposal will decrease the cost of construction .

This may decrease the cost of construction where a vestibule would no longer be required. It will not substantially change the overall cost.

Internal ID: 1020

E98-18

IBC: 1023.5, (IFC[BE] 1023.5)

Proponent: Lee Kranz, City of Bellevue, WA, representing City of Bellevue, WA (lkranz@bellevuewa.gov)

2018 International Building Code

Revise as follows:

1023.5 Penetrations. Penetrations into or through interior exit *stairways* and *ramps* are prohibited except for the following:

1. Equipment and ductwork necessary for independent ventilation or pressurization.
2. *Fire protection systems.*
3. Security systems.
4. Two-way communication systems.
5. Electrical raceway for fire department communication systems.
6. Electrical raceway serving the *interior exit stairway* and *ramp* and terminating at a steel box not exceeding 16 square inches (0.010 m²).
7. Structural elements supporting the interior exit stairway or ramp or enclosure, such as beams or joists.

Such penetrations shall be protected in accordance with Section 714. There shall not be penetrations or communication openings, whether protected or not, between adjacent interior exit *stairways* and ramps.

Exception: Membrane penetrations shall be permitted on the outside of the *interior exit stairway* and ramp. Such penetrations shall be protected in accordance with Section 714.4.2.

Reason:

It is common for structural elements such as beams and joists to penetrate interior exit stair and ramp shaft enclosures as part of the floor framing. This is commonly known as platform framing. Section 713.1 specifically excludes interior exit stairways from the shaft requirements and there isn't any direction provided in 1023 for structural elements penetrating into a stair shaft. Lacking code guidance in 1023 most building officials are using Section 713.8 provisions for structural elements. The proposed language to be inserted in Section 1023.5 is needed for interior exit stairways and ramps and is verbatim to that found in Section 713.8 for shaft enclosures.

Cost Impact

The code change proposal will not increase or decrease the cost of construction.

This code change is for clarification only and will not impact the cost of construction.

Internal ID: 100

E99-18

IBC: 1023.8, (IFC[BE] 1023.8)

Proponent: Todd Snider, West Coast Code Consultants (WC3), representing Self (Todd@KimballEng.com)

2018 International Building Code

Revise as follows:

1023.8 Discharge identification.Barriers at level of exit discharge. An interior exit stairway and *ramp* shall not continue below its *level of exit discharge* unless an *approved* barrier is provided at the *level of exit discharge* to prevent persons from unintentionally continuing into levels below. Such barrier shall not obstruct the stairway landing required by Section 1011.6 or reduce the egress width required by Section 1005. Directional exit signs shall be provided as specified in Section 1013.

Reason:

Proposed revision to rename this Section as the title is confusing and misleading.

Proposed revision to require that approved barriers provided in egress stair not obstruct the required landing or reduce required egress widths.

Cost Impact

The code change proposal will not increase or decrease the cost of construction .

The added requirement will not affect cost because this requirement is already implied and followed by most.

Internal ID: 1293

E100-18

IBC: 1023.9, 1023.10 (New), (IFC[BE] 1023.9, 1023.10 (New))

Proponent: Todd Snider, West Coast Code Consultants (WC3), representing Self (Todd@KimballEng.com)

2018 International Building Code

Revise as follows:

1023.9 Stairway identification signs. A sign shall be provided at each floor landing in an *interior exit stairway* and *ramp* connecting more than three stories designating the floor level, the terminus of the top and bottom of the *interior exit stairway* and *ramp* and the identification of the *stairway* or *ramp*. The signage shall state the story of and direction to the *exit discharge*, and the availability of roof access from the *interior exit stairway* and *ramp* for the fire department. The sign shall be located 5 feet (1524 mm) above the floor landing, measured to the bottom of the sign, in a position that is readily visible when the doors are in the open and closed positions. ~~In addition to the *stairway* identification sign, a floor-level sign in visual characters, raised characters and braille complying with ICC A117.1 shall be located at each floor-level landing adjacent to the door leading from the *interior exit stairway* and *ramp* into the *corridor* to identify the floor level.~~

Add new text as follows:

1023.10 Floor-Level sign. Where stairway identification signs are required by Section 1023.9 a separate floor-level sign shall be provided. The floor-level sign shall be in visible characters, raised characters, and braille complying with ICC A117.1 and shall be located at each floor level landing adjacent to the door leading from the interior exit stairway and ramp to identify the floor level.

Reason:

Proposed revision to clarify that the stairway identification sign and the floor-level sign are two separate signs. Floor level sign should be moved to its own section.

Cost Impact

The code change proposal will not increase or decrease the cost of construction .

Will not have cost affect. This is only clarifying existing requirements.

Internal ID: 1297

E101-18

IBC: 1024.6, (IFC[BE] 1024.6)

Proponent: David Renn, City and County of Denver, representing Code Change Committee of Colorado Chapter of the ICC (david.renn@denvergov.org)

2018 International Building Code

Revise as follows:

1024.6 Penetrations. Penetrations into or through an *exit passageway* are prohibited except for the following:

1. Equipment and ductwork necessary for independent ventilation or pressurization.
2. Fire protection systems.
3. Security systems.
4. Two-way communication systems.
5. Electrical raceway for fire department communication.
6. Electrical raceway serving the *exit passageway* and terminating at a steel box not exceeding 16 square inches (0.010 m²).

Such penetrations shall be protected in accordance with Section 714. There shall not be penetrations or communicating openings, whether protected or not, between adjacent exit passageways.

Exception: Membrane penetrations shall be permitted on the outside of the exit passageway. Such penetrations shall be protected in accordance with Section 714.4.2.

Reason:

Section 1024.7 includes requirements for "equipment and ductwork for exit passageway ventilation as permitted in Section 1024.6..."; however, Section 1024.6 currently allows equipment and ductwork for pressurization, but not for for ventilation. This proposal adds ventilation into Section 1024.6 to be consistent with Section 1024.7. This is also consistent with the allowed penetrations for interior exit stairways and ramps given in Section 1023.5.

Cost Impact

The code change proposal will not increase or decrease the cost of construction .

This change clarifies the intent of the code.

Internal ID: 1214

E102-18

IBC: 707.4, 1024.8 (New), (IFC[BE] 1024.8)

Proponent: David Renn, City and County of Denver, representing Code Change Committee of Colorado Chapter of the ICC (david.renn@denvergov.org)

2018 International Building Code

Revise as follows:

707.4 Exterior walls. Where exterior walls serve as a part of a required fire-resistance-rated shaft or ~~stairway separation or ramp enclosure~~ for a stairway, ramp or separation exit passageway, such walls shall comply with the requirements of Section 705 for exterior walls and the fire-resistance-rated enclosure or separation requirements shall not apply.

Exception: Exterior walls required to be *fire-resistance rated* in accordance with Section 1021 for exterior egress balconies, Section 1023.7 for interior exit stairways and ramps, Section 1024.8 for exit passageways and Section 1027.6 for exterior exit stairways and ramp.

Add new text as follows:

1024.8 Exit passageway exterior walls. Exterior walls of the exit passageway shall comply with Section 705. Where nonrated walls or unprotected openings enclose the exterior of the exit passageway and the walls or openings are exposed by other parts of the building at an angle of less than 180 degrees (3.14 rad), the building exterior walls within 10 feet (3048 mm) horizontally of a nonrated wall or unprotected opening shall have a fire-resistance rating of not less than 1 hour. Openings within such exterior walls shall be protected by opening protectives having a fire protection rating of not less than 3/4 hour. This construction shall extend vertically from the ground to a point 10 feet (3048 mm) above the floor of the exit passageway, or to the roof line, whichever is lower.

Reason:

The code currently has specific requirements for exterior walls of interior exit stairways and ramps, but has no specific requirements for exit passageways. This proposed change adds exterior wall requirements for exit passageways that are the same as Section 1023.7 requirements for interior exit stairways and ramps. Since exit passageways and interior exit stairways and ramps are all exit components, the current provisions for interior exit stairways and ramps should apply to exit passageways as well. This new section is proposed to be 1024.8 to be in the same general location as for interior exit stairways (i.e. after the Ventilation section).

Cost Impact

The code change proposal will decrease the cost of construction .

This change will lower cost where the fire-resistance rating of exterior walls of exit passageways can be reduced.

Internal ID: 1231

E103-18

IBC: 1025.1, (IFC[BE] 1025.1)

Proponent: Keith Flanders, Cosentini Associates, representing self (kflanders@cosentini.com)

2018 International Building Code

Revise as follows:

1025.1 General. *Approved* luminous egress path markings delineating the exit path shall be provided ~~in high-rise buildings of where serving spaces with~~ Group A, B, E, I-1, M or R-1 occupancies located more than 75 feet above the lowest level of fire department access in accordance with this section.

Exception: Luminous egress path markings shall not be required on the *level of exit discharge* in lobbies that serve as part of the exit path in accordance with Section 1028.1, Exception 1.

Reason:

Luminous egress path markings should only be required once the occupancy is located more than 75 feet above the lowest level of fire department access. Requiring luminous egress path markings for these occupancies in any portion of a high-rise building is overly restrictive. Where located below this level, the occupancy is similar to any other building less than 75 feet above the lowest level of fire department access and therefore would not require luminous egress path markings.

Additionally, the luminous egress path markings are only required for exits serving the specified occupancies. High-rise buildings often have three or more exit stairs, if a stair does not serve one of the specified occupancies, it should not be required to have luminous egress path markings. This is the reason for further defining the scope of this section.

Cost Impact

The code change proposal will decrease the cost of construction .

Based on the language of the code, luminous egress path markings are often required in locations that they are not deemed necessary. This clarifies the intent which may limit the areas that luminous egress path markings are provided.

Internal ID: 1022

E104-18

IBC: 1017.3, 1029.6.2, 1029.6.2.3, 1029.6.3.1 (New), (IFC[BE] 1017.3, 1029.6.2, 1029.6.2.3, 1029.6.3.1 (New))

Proponent: Gene Boecker, Code Consultants, Inc., representing Code Consultants, Inc. (geneb@codeconsultants.com)

2018 International Building Code

Revise as follows:

1017.3 Measurement. *Exit access* travel distance shall be measured from the most remote point of each room, area or space along the natural and unobstructed path of horizontal and vertical egress travel to the entrance to an exit.

Exception ~~Exceptions:~~

1. In open parking garages, *exit access* travel distance is permitted to be measured to the closest riser of an *exit access stairway* or the closest slope of an *exit access ramp*.
2. In smoke protected seating and open air assembly seating, exit access travel distance shall be measured in accordance with Section 1029.7.

1029.6 Capacity of aisle for assembly. The required capacity of *aisles* shall be not less than that determined in accordance with Section 1029.6.1 where *smoke-protected assembly seating* is not provided, Section 1029.6.2 where *smoke-protected assembly seating* is provided and Section 1029.6.3 where *open-air assembly seating* is provided.

1029.6.2 Smoke-protected assembly seating. The required capacity in inches (mm) of the aisle for *smoke-protected assembly seating* shall be not less than the *occupant load* served by the egress element multiplied by the appropriate factor in Table 1029.6.2. The total number of seats specified shall be those within the space exposed to the same smoke-protected environment. Interpolation is permitted between the specific values shown. A life safety evaluation, complying with NFPA 101, shall be done for a facility utilizing the reduced width requirements of Table 1029.6.2 for *smoke-protected assembly seating*.

~~**Exception:** For open air assembly seating with an occupant load not greater than 18,000, the required capacity in inches (mm) shall be determined using the factors in Section 1029.6.3.~~

**TABLE 1029.6.2
CAPACITY FOR AISLES FOR SMOKE-PROTECTED ASSEMBLY**

TOTAL NUMBER OF SEATS IN THE SMOKE-PROTECTED ASSEMBLY SEATING	INCHES OF CAPACITY PER SEAT SERVED			
	Stepped aisles with handrails within 30 inches	Stepped aisles without handrails within 30 inches	Level aisles or ramped aisles not steeper than 1 in 10 in slope	Ramped aisles steeper than 1 in 10 in slope
Equal to or less than 5,000	0.200	0.250	0.150	0.165
10,000	0.130	0.163	0.100	0.110
15,000	0.096	0.120	0.070	0.077
20,000	0.076	0.095	0.056	0.062
Equal to or greater than 25,000	0.060	0.075	0.044	0.048

For SI: 1 inch = 25.4 mm.

1029.6.2.3 Automatic sprinklers. Enclosed areas with walls and ceilings in buildings or structures containing *smoke-protected assembly seating* shall be protected with an *approved automatic sprinkler system* in accordance with Section 903.3.1.1.

Exceptions:

1. The floor area used for contests, performances or entertainment provided that the roof construction is more than 50 feet (15 240 mm) above the floor level and the use is restricted to low fire hazard uses.
2. Press boxes and storage facilities less than 1,000 square feet (93 m²) in area.
- ~~3. Outdoor seating facilities where seating and the means of egress in the seating area are essentially open to the outside.~~

1029.6.3 Open-air assembly seating. In *open-air assembly seating*, the required capacity in inches (mm) of *aisles* shall be not less than the total *occupant load* served by the egress element multiplied by 0.08 (2.0 mm) where egress is by stepped *aisle* and multiplied by 0.06 (1.52 mm) where egress is by level *aisles* and ramped *aisles*.

Exception: The required capacity in inches (mm) of *aisles* shall be permitted to comply with Section 1029.6.2 for the number of seats in the *open-air assembly seating* where Section 1029.6.2 permits less capacity.

1029.6.3.1 Automatic sprinklers. Enclosed areas with walls and ceilings in buildings or structures containing open-air assembly seating shall be protected with an approved automatic sprinkler system in accordance with Section 903.3.1.1.

Exceptions:

1. The floor area used for contests, performances or entertainment provided the roof construction is more than 50 feet (15 240 mm) above the floor level and the use is restricted to low fire hazard uses.
2. Press boxes and storage facilities less than 1,000 square feet (93 m²) in area.
3. Open-air assembly seating facilities where seating and the means of egress in the seating area are essentially open to the outside.

Reason:

The intent of this proposal is consistency with E132-15, proposed by BCAC last cycle. This proposal split smoke protected seating and open air seating with the following definitions:

OPEN-AIR ASSEMBLY SEATING. Seating served by means of egress that is not subject to smoke accumulation within or under a structure and is open to the atmosphere.

SMOKE-PROTECTED ASSEMBLY SEATING. Seating served by means of egress that is not subject to smoke accumulation within or under a structure for a specified design time by means of passive design or by mechanical ventilation.

The change of phrase from outdoor smoke protected to open air assembly seating that was done with E132-15 was missed in the exception to 1029.6.2. However, With the split, the exception in 1029.6.2 is no longer needed as a pointer. The exception in 1029.6.3 lets open air assembly seating use the lesser numbers in Table 1029.6.2 which is applicable for seating of 20,000 or more. This also answers the question about what numbers to use for open-air seating for venues from 18,000 to 20,000. For example: Current text would allow aisle capacity to use 0.08 for <=18,000 seats; 0.096 for 18,000 to 20,000 and then 0.076 for >=20,000. There is no technical justification for this.

Again, with the straight reference to 1029.6.3 for open air seating, there is a total miss for sprinklers in Section 1029.6.2.3. This would be inconsistent with IFC Section 903.2.1.5. The exception for 1029.6.2.3 should be deleted, and the appropriate information added for open air assembly seating in Section 1029.6.3.1.

[F] 903.2.1.4 Group A-4. An automatic sprinkler system shall be provided throughout stories containing Group A-4 occupancies and throughout all stories from the Group A-4 occupancy to and including the levels of exit discharge serving that occupancy where one of the following conditions exists:

1. The fire area exceeds 12,000 square feet (1115 m²).
2. The fire area has an occupant load of 300 or more.
3. The fire area is located on a floor other than a level of exit discharge serving such occupancies.

[F] 903.2.1.5 Group A-5. An automatic sprinkler system shall be provided for all enclosed Group A-5 accessory use areas in excess of 1,000 square feet (93 m²).

[F] 903.2.1.5.1 Spaces under grandstands or bleachers. Enclosed spaces under grandstands or bleachers shall be equipped with an automatic sprinkler system in accordance with Section 903.3.1.1 where either of the following exist:

1. The enclosed area is 1,000 square feet (93 m²) or less and is not constructed in accordance with Section 1029.1.1.1.
2. The enclosed area exceeds 1,000 square feet (93 m²).

Cost Impact

The code change proposal will not increase or decrease the cost of construction .

This is a correlation of requirements within Section 1029 and across codes, not new requirements.

E105-18

IBC: TABLE 1029.13.2.1, (IFC[BE] TABLE 1029.13.2.1)

Proponent: Kevin Scott, representing KH Scott & Associates LLC (khscottassoc@gmail.com)

2018 International Building Code

Revise as follows:

**TABLE 1029.13.2.1
SMOKE-PROTECTED OR OPEN-AIR ASSEMBLY AISLE ACCESSWAYS**

TOTAL NUMBER OF SEATS IN THE SMOKE-PROTECTED OR OPEN-AIR ASSEMBLY SEATING	MAXIMUM NUMBER OF SEATS PER ROW PERMITTED TO HAVE A MINIMUM 12-INCH CLEAR WIDTH AISLE ACCESSWAY			
	Aisle or doorway at both ends of row		Aisle or doorway at one end of row only	
	Seats with backrests	Seats without backrests	Seats with backrests	Seats without backrests
Less than 4,000	14	21	7	10
4,000 to 6,999	15	22	7	10
7,000 to 9,999	16	23	8	11
10,000 to 12,999	17	24	8	11
13,000 to 15,999	18	25	9	12
16,000 to 18,999	19	26	9	12
19,000 to 21,999	20	27	10	13
22,000 and greater	21	28	11	14

For SI: 1 inch = 25.4 mm.

Reason:

This proposal is editorial and only for clarification.

The first entry in the table is clear that it applies to less than 4,000. But the following entries only indicate a single value, with no indication of whether the number of seats must be exactly that number or not. Based on the heading for the first column which states "Total Number of Seats...", you could apply both "Less than 4,000" and "4,000" to a facility with 3,500 seats. This obviously was not the intent.

This proposal fills in the gaps and leaves no question as to how to apply the values in the table.

Cost Impact

The code change proposal will not increase or decrease the cost of construction.

This is editorial and does not change the application of the code requirements.

Internal ID: 2029

E106-18

IBC: 1029.16, 1029.16.1, (IFC[BE] 1029.16. 1029.16.1)

Proponent: Ed Kullik, Chair, representing ICC Building Code Action Committee (bcac@iccsafe.org)

2018 International Building Code

Revise as follows:

1029.16 Handrails. Ramped *aisles* having a slope exceeding one unit vertical in 15 units horizontal (6.7-percent slope) and stepped *aisles* shall be provided with *handrails* in compliance with Section 1014 located either at one or both sides of the *aisle* or within the *aisle* width. Where stepped aisle have seating on one side and the aisle width is 74 inches (1880 mm) or greater, two handrails are required. Where two handrails are required, one of the handrails shall be within 30 inches horizontally of the end of the aisle accessways.

Exceptions:

1. *Handrails* are not required for ramped *aisles* with seating on both sides.
2. *Handrails* are not required where, at the side of the *aisle*, there is a *guard* with a top surface that complies with the graspability requirements of *handrails* in accordance with Section 1014.3.
3. *Handrail* extensions are not required at the top and bottom of stepped *aisles* and ramped *aisles* to permit crossovers within the *aisles*.

1029.16.1 Discontinuous handrails. Where there is seating on both sides of the *aisle*, the mid-*aisle handrails* shall be ~~discontinuous with~~ discontinuous. Where the stepped aisle is required to have two handrails, handrails not located on a guard or wall shall be discontinuous. The gaps or breaks at intervals shall not exceeding five rows to facilitate access to seating and to permit crossing from one side of the *aisle* to the other. These gaps or breaks shall have a clear width of not less than 22 inches (559 mm) and not greater than 36 inches (914 mm), measured horizontally, and the mid-*aisle handrail* shall have rounded terminations or bends.

1029.16.2 Handrail termination. *Handrails* located on the side of stepped *aisles* shall return to a wall, *guard* or the walking surface or shall be continuous to the *handrail* of an adjacent stepped *aisle flight*.

1029.16.3 Mid-aisle termination. Mid-*aisle handrails* shall not extend beyond the lowest riser and shall terminate within 18 inches (381 mm), measured horizontally, from the lowest riser. *Handrail* extensions are not required.

Exception: Mid-*aisle handrails* shall be permitted to extend beyond the lowest riser where the *handrail* extensions do not obstruct the width of the cross *aisle*.

Reason:

The social stairway is a new style being used in common areas of schools and multi-assembly buildings. It appears to fall somewhere between stairways and assembly seating. If this is considered a stairway next to platforms, the general requirement for handrails on both sides of the stairway prevents access to the platforms (Example 4). Considering this configuration as assembly seating would require one handrail with current text.

This proposal considers this arrangement as a type of assembly seating. The width would have to be determined using both the general circulation number from the upper/lower floor and the seating in accordance with Section 1029.6.1, which requires extra width if a handrail is not with 30". By considering this assembly seating, accessible wheelchairs spaces would already be addressed. Drop offs along the top would have to meet guard provisions.

To address occupant safety, this proposal will require a mid-*aisle handrail* on wide stepped *aisles* in addition to the handrail on the wall. The reasoning for 74" was that we did not want either side of the handrails to create a width that was not readily useable (30" + 44" = 74"). The second handrail being within 30" of the edge of the platform allows flexibility in handrail placement, but still keeps the handrail within reach of persons moving off the platforms. Where there is not a cross *aisle*, the handrail would still have to have handrail extensions at the top and bottom, as well as meet all the other handrail provisions in Section 1014 and 1029.6. This 2nd handrails would typically not show up in stadium seating where *aisles* are typically less wide than specified here.

As you can see in the examples provided: Example 1 has two handrails, but with one on the far side of the platform. Example 4 a 2nd handrail blocks access to the platforms, so people either climb up the platforms, or go under the handrail. In example 2 and 3 a handrail is only provided on one side of the stairway, regardless of width. None of these configuration would address stairway safety and access to the platforms. Example 3 has an example handrail drawn in red of what these requirements would add.

This proposal is submitted by the ICC Building Code Action Committee (BCAC). BCAC was established by the ICC Board

of Directors in July 2011 to pursue opportunities to improve and enhance assigned International Codes or portions thereof. In 2017 the BCAC has held 3 open meetings. In addition, there were numerous Working Group meetings and conference calls for the current code development cycle, which included members of the committee as well as any interested party to discuss and debate the proposed changes. Related documentation and reports are posted on the BCAC website at: <https://www.iccsafe.org/codes-tech-support/codes/codedevelopment-process/building-code-action-committee-bcac>.



Figure 1



Figure 2



Figure 3



Figure 4

Cost Impact

The code change proposal will increase the cost of construction .

In some situations, this could require a 2nd handrail for occupant safe egress on the stairways.

Internal ID: 479

E107-18

IBC: SECTION 1030.1, (IFC[BE] 1030.1)

Proponent: Ed Kullik, Chair, representing ICC Building Code Action Committee (bcac@iccsafe.org)

2018 International Building Code

SECTION 1030 EMERGENCY ESCAPE AND RESCUE

Revise as follows:

1030.1 General. ~~Where required.~~ In addition to the *means of egress* required by this chapter, *emergency escape and rescue openings* shall be provided in the following occupancies:

1. Group R-2 occupancies located in stories with only one *exit* or *access* to only one *exit* as permitted by Tables 1006.3.3(1) and 1006.3.3(2).
2. Group R-3 and R-4 occupancies.

Basements and sleeping rooms below the fourth story above *grade plane* shall have not fewer than one ~~exterior~~ *emergency escape and rescue opening* in accordance with this section. Where *basements* contain one or more sleeping rooms, ~~an~~ *emergency escape and rescue opening* shall be required in each sleeping room, but shall not be required in adjoining areas of the *basement*. Such openings shall open directly into a *public way* or to a *yard* or *court* that opens to a *public way*.

Exceptions:

1. *Basements* with a ceiling height of less than 80 inches (2032 mm) shall not be required to have *emergency escape and rescue openings*.
2. *Emergency escape and rescue openings* are not required from *basements* or sleeping rooms that have an exit door or *exit access* door that opens directly into a *public way* or to a *yard*, *court* or exterior ~~exit~~ *egress* balcony that opens to a *public way*.
3. *Basements* ~~without habitable spaces~~ *used only to house mechanical equipment* and having not more than 200 square feet (18.6 m²) in floor area shall not be required to have *emergency escape and rescue openings*.
4. Within individual *dwelling* and *sleeping units* in Groups R-2 and R-3, where the building is equipped throughout with an *automatic sprinkler system* installed in accordance with Section 903.3.1.1, 903.3.1.2 or 903.3.1.3, *sleeping rooms* in *basements* shall not be required to have *emergency escape and rescue openings* provided that the *basement* has one of the following:
 - 4.1. One *means of egress* and one *emergency escape and rescue opening*.
 - 4.2. Two *means of egress*.

Reason:

This is one of a series of 11 proposals to coordinate the Emergency Escape and Rescue Openings (EERO) technical criteria in the IBC and IRC. Please see the proposal for the definition of Emergency Escape and Rescue Openings for additional information. Due to the code development schedule the proposals for IBC will be proposed in Group A and the proposals for IRC will be proposed in Group B.

IBC

The definition includes 'exterior', so it does not need to be repeated in the text.

It was decided not to add the IRC defined 'habitable attic'. If added to the IBC, would the IBC also have to pick up the definition and the number of stories below the habitable attic space? (the IRC definition says this is not a story).

IBC Exception 2 - change to correct term for 'exterior egress balcony'

IBC Exception 3 - coordination with IRC, limit is just size without additional criteria for habitable.

Add storm shelter exception to IBC. Reference ICC 500 so that the escape openings provided are what is specified for storm shelters.

There will be a similar proposal for the IRC in Group B.

This proposal is submitted by the ICC Building Code Action Committee (BCAC). BCAC was established by the ICC Board of Directors in July 2011 to pursue opportunities to improve and enhance assigned International Codes or portions thereof. In 2017 the BCAC has held 3 open meetings. In addition, there were numerous Working Group meetings and conference calls for the current code development cycle, which included members of the committee as well as any

interested party to discuss and debate the proposed changes. Related documentation and reports are posted on the BCAC website at: <https://www.iccsafe.org/codes-tech-support/codes/codedevelopment-process/building-code-action-committee-bcac>.

Cost Impact

The code change proposal will not increase or decrease the cost of construction .

This is a coordination item for exceptions for EEROs already permitted between the codes.

Internal ID: 458

E108-18

IBC: 1030.1.1, (IFC[BE] 1030.1.1)

Proponent: Ed Kullik, Chair, representing ICC Building Code Action Committee (bcac@iccsafe.org)

2018 International Building Code

Revise as follows:

1030.1.1 Operational constraints and opening control devices. *Emergency escape and rescue openings shall be operational from inside the room without the use of keys or tools. Window-opening control devices ~~complying with ASTM F2090 shall be permitted for use on windows serving as a required emergency escape and rescue opening~~ shall comply with ASTM F2090.*

Reason:

This is one of a series of 11 proposals to coordinate the Emergency Escape and Rescue Openings (EERO) technical criteria in the IBC and IRC. Please see the proposal for the definition of Emergency Escape and Rescue Openings for additional information. Due to the code development schedule the proposals for IBC will be proposed in Group A and the proposals for IRC will be proposed in Group B.

IBC - Last sentence reworded as a requirement to be consistent with IRC

This proposal is submitted by the ICC Building Code Action Committee (BCAC). BCAC was established by the ICC Board of Directors in July 2011 to pursue opportunities to improve and enhance assigned International Codes or portions thereof. In 2017 the BCAC has held 3 open meetings. In addition, there were numerous Working Group meetings and conference calls for the current code development cycle, which included members of the committee as well as any interested party to discuss and debate the proposed changes. Related documentation and reports are posted on the BCAC website at: <https://www.iccsafe.org/codes-tech-support/codes/codedevelopment-process/building-code-action-committee-bcac>.

Cost Impact

The code change proposal will not increase or decrease the cost of construction .

This is a coordination item for requirements for EEROs already permitted between the codes.

Internal ID: 459

E109-18

IBC: 1030.2, 1030.2.1, 1030.3, (IFC[BE] 1030.2, 1030.2.1, 1030.3)

Proponent: Ed Kullik, Chair, representing ICC Building Code Action Committee (bcac@iccsafe.org)

2018 International Building Code

Add new text as follows:

1030.2 Emergency escape and rescue openings. Emergency escape and rescue openings shall have minimum dimensions in accordance with Section 1030.2.1 through 1030.2.3.

Revise as follows:

~~1030.2~~**1030.2.1 Minimum size.** *Emergency escape and rescue openings* shall have a minimum net clear opening of 5.7 square feet (0.53 m²).

Exception: The minimum net clear opening for *grade-floor emergency escape and rescue openings* shall be 5 square feet (0.46 m²).

~~1030.2~~**1030.2.2 Minimum dimensions.** The minimum net clear opening height dimension shall be 24 inches (610 mm). The minimum net clear opening width dimension shall be 20 inches (508 mm). The net clear opening dimensions shall be the result of normal operation of the opening.

~~1030.3~~**1030.2.3 Maximum height from floor.** ~~Emergency~~ *Where a window is provided as the emergency escape and rescue openings, such window* shall have the bottom of the clear opening not greater than 44 inches (1118 mm) measured from the floor.

Reason:

This is one of a series of 11 proposals to coordinate the Emergency Escape and Rescue Openings (EERO) technical criteria in the IBC and IRC. Please see the proposal for the definition of Emergency Escape and Rescue Openings for additional information. Due to the code development schedule the proposals for IBC will be proposed in Group A and the proposals for IRC will be proposed in Group B.

This proposal deals with Minimum size, dimensions and height.

IBC 310.3 – revise to coordinate language and organization with the IRC.

There will be a similar proposal to Group B for IRC:

This proposal is submitted by the ICC Building Code Action Committee (BCAC). BCAC was established by the ICC Board of Directors in July 2011 to pursue opportunities to improve and enhance assigned International Codes or portions thereof. In 2017 the BCAC has held 3 open meetings. In addition, there were numerous Working Group meetings and conference calls for the current code development cycle, which included members of the committee as well as any interested party to discuss and debate the proposed changes. Related documentation and reports are posted on the BCAC website at: <https://www.iccsafe.org/codes-tech-support/codes/codedevelopment-process/building-code-action-committee-bcac>.

Cost Impact

The code change proposal will not increase or decrease the cost of construction .

This is a coordination item for requirements for EEROs already permitted between the codes.

Internal ID: 460

E110-18

IBC: 1030.3 (New), (IFC[BE] 1030.3 (New))

Proponent: Ed Kullik, Chair, representing ICC Building Code Action Committee (bcac@iccsafe.org)

2018 International Building Code

Add new text as follows:

1030.3 Emergency escape and rescue doors. Where a door is provided as the required emergency escape and rescue opening, it shall be a swinging door or a sliding door.

Reason:

This is one of a series of 11 proposals to coordinate the Emergency Escape and Rescue Openings (EERO) technical criteria in the IBC and IRC. Please see the proposal for the definition of Emergency Escape and Rescue Openings for additional information. Due to the code development schedule the proposals for IBC will be proposed in Group A and the proposals for IRC will be proposed in Group B.

This proposal deals with doors used as emergency escape and rescue openings. IBC and IRC have different phrases for types of doors. Rather than totally separate requirements for doors and windows, the intent of this proposal is to use the same criteria as much as possible. That is literally what the current IRC text does, but with a lot of duplication.

There will be a coordination change for IRC as part of Group B.

This proposal is submitted by the ICC Building Code Action Committee (BCAC). BCAC was established by the ICC Board of Directors in July 2011 to pursue opportunities to improve and enhance assigned International Codes or portions thereof. In 2017 the BCAC has held 3 open meetings. In addition, there were numerous Working Group meetings and conference calls for the current code development cycle, which included members of the committee as well as any interested party to discuss and debate the proposed changes. Related documentation and reports are posted on the BCAC website at: <https://www.iccsafe.org/codes-tech-support/codes/codedevelopment-process/building-code-action-committee-bcac>.

Cost Impact

The code change proposal will not increase or decrease the cost of construction .

This is a coordination item for requirements for EEROs already permitted between the codes.

Internal ID: 461

E111-18

IBC: 1030.4, 1030.4.1, 1030.4.2, 1030.4.2.1 (New), 1030.4.3 (New), 1030.5, (IFC[BE] 1030.4, 1030.4.1, 1030.4.2, 1030.4.2.1 (New), 1030.4.3 (New), 1030.5)

Proponent: Ed Kullik, Chair, representing ICC Building Code Action Committee (bcac@iccsafe.org)

2018 International Building Code

Revise as follows:

1030.4 Window Area wells. ~~An emergency escape and rescue opening with a finished sill height the bottom of the clear opening below the adjacent ground level grade shall be provided with a window an area well in accordance with Sections 1030.4.1 and 1030.4.2 through 1030.4.4.~~

1030.4.1 Minimum size. The minimum horizontal area of the ~~window area well~~ shall be 9 square feet (0.84 m²), with a ~~minimum dimension of horizontal projection and width of not less than 36 inches (914 mm).~~ The area ~~of the window well~~ shall allow the *emergency escape and rescue opening* to be fully opened.

Exception: The ladder or steps required by Section 1030.4.2.1 shall be permitted to encroach not more than 6 inches (152 mm) into the required dimensions of the area well.

1030.4.2 Ladders or steps. ~~Window Area wells with a vertical depth of more than 44 inches (1118 mm) shall be equipped with an approved permanently affixed ladder or steps. Ladders or rungs shall have an inside width of not less than 12 inches (305 mm), shall project not less than 3 inches (76 mm) from the wall and shall be spaced not more than 18 inches (457 mm) on center (o.c.) vertically for the full height of the window well. The ladder or steps shall not encroach into the required dimensions of the window well by more than 6 inches (152 mm). The ladder or steps shall not be obstructed by the emergency escape and rescue opening when the window or door is in the open position. Ladders or steps required by this section are exempt from the stairway requirements of shall not be required to comply with Section 1011.~~

Add new text as follows:

1030.4.2.1 Ladders. Ladders or rungs shall have an inside width of at least 12 inches (305 mm), shall project at least 3 inches (76 mm) from the wall and shall be spaced not more than 18 inches (457 mm) on center (o.c.) vertically for the full height of the area well.

1030.4.3 Drainage. Area wells shall be designed for proper drainage by connecting to the building's foundation drainage system required by Section 1805.

Exception: A drainage system for area wells is not required where the foundation is on well-drained soil or sand-gravel mixture soils in accordance with the United Soil Classification System, Group I Soils, in accordance with Section 1803.5.1.

Revise as follows:

~~1030.5~~**1030.4.4 Bars, grilles, covers and screens.** ~~Where bars, grilles, covers, screens or similar devices are permitted to be placed over emergency escape and rescue openings, bulkhead enclosures or window area wells that serve such openings, provided that the minimum net clear opening size complies shall comply with Sections 1030.1.1 through 1030.4.2 1030.2.2 and such 1030.4. Such devices shall be releasable or removable from the inside without the use of a key, tool or force greater than that which is required for normal operation of the emergency escape and rescue opening. Where such bars, grilles, covers, screens or similar devices are installed in existing buildings, they shall not reduce the net clear opening of the emergency escape and rescue opening and smoke alarms shall be installed in accordance with Section 907.2.10 regardless of the valuation of the alteration.~~

Reason:

This is one of a series of 11 proposals to coordinate the Emergency Escape and Rescue Openings (EERO) technical criteria in the IBC and IRC. Please see the proposal for the definition of Emergency Escape and Rescue Openings for additional information. Due to the code development schedule the proposals for IBC will be proposed in Group A and the proposals for IRC will be proposed in Group B.

This proposal deals with area wells. There will be a coordinated change for IRC in Group B.

IBC 1030.4 - The same point of measurement should be used for both the maximum height above floor (section above) and the window well. Should not mix 'grade' and 'ground level'.

IBC 1030.4.1 - “horizontal projection and width” is more specific. IBC exception for ladder encroachment moved up from 1030.4.2.

IBC 1030.4.2 - IBC encroachment of ladder into well moved up to 1030.4.1. IRC. The sentence about the window not obstructing the ladder has been clarified. Added ‘doors’. Requirements for ladders moved into separate section.

IBC 1030.4.3 - No change to requirements. Just pulled out to separate section.

IBC 1030.4.4 - Revisions for coordination. Reference to emergency and escape opening size and minimum window well size. IBC existing building sentence should be in IEBC. “Special knowledge is revised to be consistent with IBC - the term allows for too broad of an interpretation.

There will be a coordination change for IRC as part of Group B.

This proposal is submitted by the ICC Building Code Action Committee (BCAC). BCAC was established by the ICC Board of Directors in July 2011 to pursue opportunities to improve and enhance assigned International Codes or portions thereof. In 2017 the BCAC has held 3 open meetings. In addition, there were numerous Working Group meetings and conference calls for the current code development cycle, which included members of the committee as well as any interested party to discuss and debate the proposed changes. Related documentation and reports are posted on the BCAC website at: <https://www.iccsafe.org/codes-tech-support/codes/codedevelopment-process/building-code-action-committee-bcac>.

Cost Impact

The code change proposal will not increase or decrease the cost of construction .

This is a coordination item for requirements for EEROs already permitted between the codes.

Internal ID: 462

E112-18

IBC: 1030.4.2.2 (New), (IFC[BE] 1030.4.2.2(New))

Proponent: Ed Kullik, Chair, representing ICC Building Code Action Committee (bcac@iccsafe.org)

2018 International Building Code

Add new text as follows:

1030.4.2.2 Steps. Steps shall have an inside width of not less than 12 inches (305 mm), shall have treads greater than 5 inches (127 mm) in depth and a riser height not greater than 18 inches (457 mm) for the full height of the area well.

Reason:

This is one of a series of 11 proposals to coordinate the Emergency Escape and Rescue Openings (EERO) technical criteria in the IBC and IRC. Please see the proposal for the definition of Emergency Escape and Rescue Openings for additional information. Due to the code development schedule the proposals for IBC will be proposed in Group A and the proposals for IRC will be proposed in Group B.

The current provisions says ladders and steps don't have to comply with the standard stairway provisions, however, while specific provisions are provided for ladders, no limits are provided for steps. The option here it the same width and distance between steps are permitted for ladders. The tread depth is the minimum width from alternating tread devices and ships ladders.

Following are examples of stepped configurations that are used today. The proposed language would allow for the use of Figures 1 and 3, but not 2 and 4.

This proposal is submitted by the ICC Building Code Action Committee (BCAC). BCAC was established by the ICC Board of Directors in July 2011 to pursue opportunities to improve and enhance assigned International Codes or portions thereof. In 2017 the BCAC has held 3 open meetings. In addition, there were numerous Working Group meetings and conference calls for the current code development cycle, which included members of the committee as well as any interested party to discuss and debate the proposed changes. Related documentation and reports are posted on the BCAC website at: <https://www.iccsafe.org/codes-tech-support/codes/codedevelopment-process/building-code-action-committee-bcac>.



Figure 1



Figure 2



Figure 3



Figure 4

Cost Impact

The code change proposal will increase the cost of construction .

There would be an increase for costs at EEROs where a home owner wanted to have the option of a stepped area well. This could possibly add extra steps, but there is not an increase in size requirements.

Internal ID: 463

E113-18

IBC: 1030.6 (New), (IFC[BE] 1013.6 (New))

Proponent: Micah Chappell, representing City of Seattle (micah.chappell@seattle.gov)

2018 International Building Code

Add new text as follows:

1030.6 Drainage. Window wells shall be designed for proper drainage by connecting to the building's foundation drainage system required by Section 1805.4.2 or by an approved alternative method.

Reason:

This new section will align the IBC for the drainage of window wells with a similar requirement already found in IRC R310.2.3.2 Drainage. This new code requirement would be easily implemented during the general plan review process. The purpose of the section is to prevent the flooding of emergency escape and rescue openings.

Cost Impact

The code change proposal will not increase or decrease the cost of construction .

The connection of window well drainage to the required foundation drainage system will have an initial cost increase for the materials and labor for the required connection. This initial cost could be offset over the life of the structure by mitigating possible damages caused by the potential moisture intrusion from water accumulation in the bottom of the window well.

Internal ID: 1691

E114-18

IBC: 1104.4

Proponent: Ed Kullik, representing ICC Building Code Action Committee (bcac@iccsafe.org)

2018 International Building Code

Revise as follows:

1104.4 Multistory buildings and facilities. At least one *accessible route* shall connect each *accessible story, facilities*

Exceptions:

1. An *accessible route* is not required to *stories*, of not more than 3,000 square feet (278.7 m²) and are located above and below *accessible* levels. This exception shall not apply to:
 - 1.1. Multiple tenant facilities of Group M occupancies containing five or more tenant spaces used for the sales or rental of goods and where at least one such tenant space is located on a floor level above or below the *accessible* levels.
 - 1.2. *Stories* or *mezzanines* containing offices of health care providers (Group B or I).
 - 1.3. Passenger transportation facilities and airports (Group A-3 or B).
 - 1.4. Government buildings.
 - 1.5. Structures with 4 or more dwelling units.
2. *Stories/mezzanines* contain *accessible* elements or other spaces as determined by Section 1107 or 1108 are not required to be served by an *accessible route* from an *accessible* level.
3. In air traffic control towers, an *accessible route* is not required to serve the cab and the floor immediately below the cab.
4. Where a two-story building or facility has one *story* or *mezzanine* with an *occupant load* of five or fewer persons that does not contain *public use space*, that *story* or *mezzanine* shall not be required to be connected by an *accessible route* to the *story* above or below.

Reason:

The intent of this proposal is a correlation items so that the efficiency units do not conflict with the Type B requirements in the codes.

The best way to explain the need for this is to use the example of a two story building with apartments over another use, such as parking or mercantile. Section 1107.7.1.1 would require Type B units on that 2nd floor. With typical apartments, it would be very unlikely for 4 apartments and the corridor to have an area of less than 3,000 sq. ft. Therefore, they would not be able to use Section 1104.4 Exception 1 - which is correlated with Fair Housing requirements. However, with efficiency units (IBC Section 1207.4 and IPC Section 404.6) , there could be 4 or more efficiency units with a total area of less than 3,000 sq.ft. The addition of Item 1.5 would clarify that Section 1104.4 Exception 1 should not be used for dwelling units. Other apartment building arrangements would continue to use Section 1104.4 Exception 2.

This is important because the market is trending toward smaller living areas in multi-family R-2 structures particularly in urban areas. US Census statistics show that in 2000, app. 46,000 rental units built were less than 1,000 sq.ft. In 2015, 114,000 units and in 2016, 99,000 units were less than 1,000 sq.ft. The Urban Land Institute reported in 2013 that major Municipalities including New York City, San Francisco, Boston, Dallas and Philadelphia are allowing smaller apartments with Seattle and Portland (OR) having no minimum sizes.

This proposal is submitted by the ICC Building Code Action Committee (BCAC). BCAC was established by the ICC Board of Directors in July 2011 to pursue opportunities to improve and enhance assigned International Codes or portions thereof. In 2017 the BCAC has held 3 open meetings. In addition, there were numerous Working Group meetings and conference calls for the current code development cycle, which included members of the committee as well as any interested party to discuss and debate the proposed changes. Related documentation and reports are posted on the BCAC website at: <https://www.iccsafe.org/codes-tech-support/codes/code-development-process/building-code-action-committee-bcac>.

Cost Impact

The code change proposal will increase the cost of construction .

This provision would require a elevator in buildings with four or more efficiency units on the 2nd floor over other

occupancies where the 2nd floor area was less than 3,000 sq.ft. However, this is already a requirement under the Fair Housing Accessibility Guidelines, so you are helping developers/architects/municipalities reduce the chance of being sited and retrofitting to add an elevator at a later date. This would not have any effect on larger buildings or buildings with apartments on the 1st floor.

Internal ID: 3400

E115-18

IBC: 1105.1, 1105.1.1 (New), TABLE 1105.1.1 (New)

Proponent: Joseph Hetzel, Thomas Associates, Inc., representing American Association of Automatic Door Manufacturers (Jhetzel@thomasamc.com)

2018 International Building Code

Revise as follows:

1105.1 Public entrances. In addition to *accessible* entrances required by Sections ~~1105.1-1105.1.2~~ through ~~1105.1.7-1105.1.8~~, at least 60 percent of all *public entrances* shall be *accessible*.

Exceptions:

1. An *accessible* entrance is not required to areas not required to be *accessible*.
2. Loading and *service entrances* that are not the only entrance to a tenant space.

Add new text as follows:

1105.1.1 Automatic doors. In facilities with the occupancies and building occupant loads indicated in Table 1105.1.1, at least one accessible exterior public entrance shall be either a full power-operated door or a low-energy power-operated door.

**TABLE 1105.1.1
PUBLIC ENTRANCE WITH POWER-OPERATED DOOR**

<u>OCCUPANCY</u>	<u>BUILDING OCCUPANT LOAD GREATER THAN</u>
<u>A-1, A-2, A-3, A-4</u>	<u>300</u>
<u>B, M, R-1</u>	<u>500</u>

Reason:

1. Enhances accessibility. It is widely accepted that automatic doors in general enhance overall accessibility, by accommodating a wide array of conditions people have that qualify them to need accessibility at facility entrances. This accommodates a wide variety of accessibility needs that manual doors being installed today cannot encompass.
2. Considers "transient" use. The Table directly addresses people who infrequently use public entrances so that they would need no special knowledge, skill or tool to enter a facility. All occupancies included in the Table experience such "transient" use.
3. Addresses a public need. The occupancies cited are associated with a serious existing need for automatic doors. The safety of both use and moving people in and out of buildings in those occupancies by using only manually operated doors is a major concern particularly in emergency situations.
4. Focuses on public entrances. The Table applies where the public is most likely to access facilities. Regarding which public entrance to choose for an automatic door if multiple entrances are accessible, this is left to the building designer on which would be best but the requirement of "at least one" door allows the designer to consider all entrances if feasible.
5. Occupancies involved are those most applicable to the public. The population requiring accessibility commonly needs accommodations to enter assembly, business, mercantile, and hotel/motel facilities as part of their everyday life. No code requirement for automatic doors means an increased safety risk and a decreased accessibility convenience.
6. Brings completion to accessible entrance provisions. The Table is needed in Section 1105, where accessible entrances are governed.
7. No disproportional economic burden. The thresholds have been chosen so as not to be a requirement for smaller occupancies such as small assembly facilities or strip mall businesses.
8. Addresses statistical need for accessibility. The thresholds also assume that a minimum of 2% of the population will be in need of accessibility at any given time for the specified occupancies. For an occupant load of 300, this means that at least six people will have the need that an automatic door will provide. The anticipated accessibility need should exceed this estimate a large enough percentage of time to constitute a critical mass of facilities needing

power-operated doors when meeting the established thresholds.

9. Enhances public safety. Automatic doors are regulated by ANSI/BHMA safety standards intended to prevent people from coming in contact with moving doors. Facilities employing automatic doors are required to abide by these requirements, which affords protection to anyone - including children, the elderly, and/or those with accessibility needs - in the vicinity of moving doors while minimizing or preventing operational problems. Automatic doors are thus far safer in the marketplace than manually operated doors.

10. Favorably increases facility usage. Those with accessibility needs are less likely to choose to use a facility without an automatic door, therefore resulting in reduced institutional, social, and economic benefits to entities operating within a facility.

11. Occupant load thresholds have related code precedence. The justification of minimum occupant load uses Risk Category and minimum number of exits as starting points, since these are the only locations in the Code with occupancy thresholds to consider. Risk Category and minimum number of exits share a common concern with automatic doors because the threshold numbers represent a critical mass of people above which a unique set of code requirements need to apply. Following is an explanation of how the threshold numbers have been arrived at for each occupancy in the Table.

o Group A: Also from Table 1604.5, Risk Category III. The scope of public assemblies is an occupant load greater than 300.

o Groups B, M and R-1: From Table 1006.3.1, minimum number of exits or access to exits per story. Table 1006.3.1 states that three exits or exit access doorways shall be provided from any space with an occupant load of 501 to 1000, and four shall be provided with an occupant load greater than 1000. The proposed Table would set a threshold of three exits or exit access doorways, in a given story with a public entrance, to require an automatic door at that public entrance. R-1 is the applicable Group R occupancy because hotels and motels should be encompassed by the Table where the threshold occupant load would be appropriate for those structures.

12. Alleviates concerns about maximum manual force required to operate an entrance door. Although the IBC regulates this maximum force, any type of force needed to operate a manual door is a concern for the accessibility community. Automatic doors would require no force to operate.

13. Alleviates concerns about manual force variations. Wind pressures, internal building stack pressures, and/or increasing hardware friction are common concerns and affect manual operation of entrance doors all throughout the country. This concern is removed since automatic doors require no force to operate.

14. More than a "best practice" requirement. The requirement is a need, as opposed to a "best practice", because automatic doors encourage people to use facilities, are safer, and more efficiently move people in and out of buildings. It is widely known that people - particularly children, the elderly, and/or those with accessibility needs - have great difficulty, or find it impossible, to open entrance doors because of stack pressures, door configurations, door friction, wind, or door weight.

Cost Impact

The code change proposal will increase the cost of construction .

The increased construction cost will be outweighed by the benefits provided to the public as outlined in our reasoning statement.

Internal ID: 361

E116-18

IBC: 1106.2, 1111.1

Proponent: Jim Safranek, representing Safranek Group LLC

2018 International Building Code

Revise as follows:

1106.2 Groups I-1, R-1, R-2, R-3 and R-4. *Accessible* parking spaces shall be provided in Group I-1, R-1, R-2, R-3 and R-4 occupancies in accordance with Items 1 through 4 as applicable.

1. In Group R-2, R-3 and R-4 occupancies that are required to have *Accessible, Type A* or *Type B dwelling units* or *sleeping units*, at least 2 percent, but not less than one of the parking serving the residents, of each type of parking space provided shall be *accessible*. Where guest parking is provided that serve the residents, at least 2 percent, but not less than one of the parking spaces provided for guests shall be accessible.
2. In Group I-1 and R-1 occupancies, *accessible* parking shall be provided in accordance with Table 1106.1.
3. Where at least one parking space is provided for each *dwelling unit* or *sleeping unit*, at least one *accessible* parking space shall be provided for each *Accessible* and *Type A unit*.
4. Where parking is provided within or beneath a building, *accessible* parking spaces shall be provided within or beneath the building.

1111.1 Signs. Required *accessible* elements shall be identified by the International Symbol of Accessibility at the following locations.

1. *Accessible* parking spaces required by ~~Section~~ Sections 1106.1, 1106.3 or 1106.4.
Exception: Where the total number of parking spaces provided is four or less, identification of *accessible* parking spaces is not required.
2. *Accessible* parking spaces required by Section 1106.2. Where accessible parking spaces are required for guests of residents, such spaces shall also be designated at guest parking.
Exception: In Group I-1, R-2, R-3 and R-4 facilities, where parking spaces are assigned to specific *dwelling units* or *sleeping units*, identification of *accessible* parking spaces is not required.
3. *Accessible* passenger loading zones.
4. *Accessible* rooms where multiple single-user toilet or bathing rooms are clustered at a single location.
5. *Accessible* entrances where not all entrances are *accessible*.
6. *Accessible* check-out aisles where not all aisles are *accessible*. The sign, where provided, shall be above the check-out aisle in the same location as the checkout aisle number or type of check-out identification.
7. Family or assisted-use toilet and bathing rooms.
8. *Accessible* dressing, fitting and locker rooms where not all such rooms are *accessible*.
9. *Accessible* areas of refuge in accordance with Section 1009.9.
10. Exterior areas for assisted rescue in accordance with Section 1009.9.
11. In recreational facilities, lockers that are required to be *accessible* in accordance with Section 1109.9.

Reason:

Purpose: To clarify the accessible parking requirements for resident guest/visitor parking associated with Group R-2, R-3, and R-4.

Reason and Substantiation: As currently written, item 1 for section 1106.2 requires a minimum of 2%, but not less than 1 accessible parking space for each "type" of parking space provided. The International Building Code does not identify what represents a "type" of parking space. For Group R-2 projects, some of the potential "types" of parking spaces

include the following:

- Parking garage
- Open parking lot
- Carports
- Individual stand-alone garages
- Tuck under building garages
- Secured parking
- Unsecured parking

Normally, the "types" of parking associated with Item 1 for section 1106.2 represent either a different type of physical structure for the parking or possibly a different condition for the parking (such as secured/unsecured). Additionally, the "types" of parking associated with Item 1 for section 1106.2 do not normally represent a distinct user group such as resident or resident guest/visitor. Because of that, it appears to be unclear in the International Building Code as to the requirements for accessible parking spaces, where resident guest/visitor parking is provided for Groups R-2, R-3, and R-4 occupancies. This is often the case for Group R-2 apartment projects where there are distinct parking spaces identified solely for use by resident guests/visitors. The proponent is aware of some jurisdictions that have interpreted that Table 1106.1 be used for Group R-2 resident guest/visitor parking and other jurisdictions that have interpreted that item 1 of section 1106.2 is applicable. As section 1106.2 is currently written, a jurisdiction could interpret that for a Group R-2 apartment project, item 1 for section 1106.2 would be applicable for the Group R-2 parking, inclusive of resident and resident guests/visitors. At that point, it appears that section 1106.2 does not provide guidance for allotting the minimum required accessible parking spaces for the R-2 occupancy between the residents and resident guests/visitors, unless they are classified as a "type" of parking based on different user groups.

For reference, the Fair Housing Act (FHA) Guidelines, require that a "sufficient" number of accessible parking spaces be provided where resident guest/visitor parking is provided. This FHA requirement for resident guest/visitor accessible parking is distinct and separate from the FHA requirement for accessible parking associated with units.

The item proposed to be added to section 1106.2 seeks to clarify the accessible parking requirements for resident guest/visitor parking for Group R-2 occupancies and align it with FHA requirements for resident guest/visitor parking that classify it as a distinct and separate type of parking that requires its own accessible parking spaces. If the Committee believes that section 1106.2 currently encompasses resident guest/visitor parking, the proponent requests that language be added to section 1106.2 clarifying this intent and ensuring that accessible parking will be provided at locations where resident guest/visitor parking is provided. If the Committee believes that Table 1106.1 is applicable for resident guest/visitor parking, the proponent requests that language found in the proponents proposed code addition in item 5 for section 1106.2 be revised to reflect this.

Cost Impact

The code change proposal will not increase or decrease the cost of construction .

The construction cost impact for the proposed code change will depend upon how jurisdictions currently determine accessible parking, where parking solely for resident guests/visitors is provided.

Where jurisdictions currently use Table 1106.1, the proposed code change language will result in a reduction in construction costs. This comes about from a reduction in accessible parking spaces (as much as 1/2) and their associated construction (including accessible routes) for parking areas (solely for resident guests/visitors) with less than 301 vehicles.

Where jurisdictions currently use Item 1 in section 1106.2 and require 2% of the combined resident and resident guest/visitor parking to be accessible, the proposed code change language will result in an increase in construction costs. This comes about from an increase in the number of accessible parking spaces and their associated construction (including accessible routes) for parking areas (solely for resident guests/visitors).

Internal ID: 1601

E117-18

IBC: 1106.2

Proponent: Jim Safranek, representing Safranek Group LLC

2018 International Building Code

Revise as follows:

1106.2 Groups I-1, R-1, R-2, R-3 and R-4. Accessible parking spaces shall be provided in Group I-1, R-1, R-2, R-3 and R-4 occupancies in accordance with Items 1 through 4 as applicable.

1. In Group R-2, R-3 and R-4 occupancies that are required to have *Accessible, Type A or Type B dwelling units or sleeping units*, at least 2 percent, but not less than one, of each type of parking space provided shall be *accessible*.
2. In Group I-1 and R-1 occupancies, *accessible* parking shall be provided in accordance with Table 1106.1.
3. Where at least one parking space is provided for each *dwelling unit or sleeping unit*, in addition to the accessible parking in Items 1 and 2, and at least one *accessible* parking space shall be provided for each *Accessible and Type A unit*.
4. Where parking is provided within or beneath a building, *accessible* parking spaces shall be provided within or beneath the building.

Reason:

Purpose: To clarify whether the number of parking space required by item 3 of section 1106.2 are in addition to the minimum required number of accessible parking spaces or are included as part of the minimum required number of accessible parking spaces.

Reason and Substantiation: For groups I-1, R-1, R-2, R-3 and R-4 the required minimum number of accessible parking spaces is either 2% (Group R-2, R-3 and R-4) or per Table 1106.1 (Group I-1 and R-1). Additionally, item 3 in section 1106.2 states, "Where a parking space is provided for each dwelling unit or sleeping unit, at least one accessible parking space shall be provided for each Accessible and Type 'A' unit.". Item 3 does not appear to clarify whether the required parking spaces for Accessible and Type 'A' units are included among the required minimum number of accessible spaces (either 2% of provided parking spaces or per Table 1106.1), or, are in addition to the required minimum number of accessible spaces.

For example, given a Group R-2 apartment project with 250 parking stalls for 250 units (1 parking stall per unit), where 5 of the units are Type 'A' units and the remaining units are Type 'B' units and there are 5 accessible parking spaces provided. Do the requirements of Section 1106.2, item 3 mean the following:

1. that a minimum of 5 accessible parking spaces will be required ($250 \times 2\% = 5$, per section 1106.2, item 1) and this also corresponds to the minimum number of required and provided Type 'A' units (1106.2, item 3)?
2. or, that in addition to the minimum required accessible parking spaces (5) (section 1106.2, item 1), 5 additional parking spaces will be required for each of the provided Type 'A' units (per section 1106.2, item 3), resulting in a total of 10 accessible parking spaces?

The proposed additional language to item 3 of section 1106.2 seeks to clarify its intent.

Cost Impact

The code change proposal will not increase or decrease the cost of construction .

Whether or not the code change proposal will increase or decrease the cost of construction depends upon how jurisdictions have been interpreting item 3 of section 1106.2.

If jurisdictions have been interpreting that accessible parking spaces required by item 1 of section 1106.2 do not include the accessible parking spaces required by item 3 of section 1106.2 (which must be also be additionally provided), this will not increase construction costs. The reason for this is that the jurisdiction's interpretation of items 1 and 3 of section 1106.2 is consistent with the code change proposal, that reflects the intent of the code.

If jurisdictions have been interpreting that accessible parking spaces required by item 1 of section 1106.2 include the accessible parking spaces required by item 3 of section 1106.2, this will increase construction costs. The reason for this is that the jurisdiction's interpretation of items 1 and 3 of section 1106.2 is not consistent with the code change proposal and additional accessible parking spaces and their accompanying accessible access aisles and accessible routes will be required.

E118-18

IBC: 1106.5

Proponent: Jim Safranek, representing Safranek Group LLC (info@safranekgroup.com)

2018 International Building Code

Revise as follows:

1106.5 Van spaces. For every six or fraction of six *accessible* parking spaces, at least one shall be a van-accessible parking space.

Van-accessible spaces shall be determined and dispersed in accordance with the following:

Where accessible parking spaces on the site are determined in accordance with only one of Sections 1106.1, 1106.2, 1106.3 or 1106.4, the number of van-accessible parking spaces shall be determined by counting all the accessible parking spaces on the site. Where accessible parking spaces are provided in more than one location, van-accessible parking spaces shall be distributed.

Where accessible parking spaces on the site are determined in accordance with any combination of Sections 1106.1, 1106.2, 1106.3 and 1106.4, the number of van-accessible spaces shall be determined by counting the accessible spaces on the site required to comply with each section. Where accessible parking spaces are provided in more than one location, van-accessible parking spaces shall be distributed within the parking associated with the requirements for each section.

Exception-Exceptions:

1. Van-accessible parking spaces are not required to be distributed by type of parking in accordance with Section 1106.2.
2. In Group U private garages that serve Group R-2 and R-3 occupancies, van-accessible spaces shall be permitted to have vehicular routes, entrances, parking spaces and access aisles with a minimum vertical clearance of 7 feet (2134 mm).

Reason:

Purpose: Parking areas for many projects consist of multiple parking facilities, multiple types of parking, and multiple occupancies served by the parking facilities. For these circumstances, section 1106.5 does not currently provide clear provisions for determining the minimum number of required accessible parking spaces for vans and their distribution. Interpretations for determining the minimum number of accessible parking spaces for vans and their distribution vary among jurisdictions. The proposed code language seeks to bring consistency by:

1. identifying the methodology for determining the minimum number of required accessible parking spaces for vans where multiple parking facilities occur
2. identifying the distribution of the required accessible parking spaces for vans where there are:
 - a.) multiple parking facilities on one site subject to both section 1106.1 and section 1106.2 item 1
 - b.) multiple types of parking spaces associated with Group R-2, R-3, and R-4 occupancies on one site
3. aligning with the requirements found in the 2010 ADA Standards for Accessible Design and those found in the Fair Housing Act Guidelines
4. ensuring the availability of accessible van parking spaces for multiple, varying occupancies (each, possibly having their own separate parking facilities) on one site

Reason: The current language in section 1106.5 does not address how the number of accessible parking spaces for vans spaces are determined when there are multiple parking facilities on one site. Here is an example:

Example: Given a privately funded apartment project on one site with common-use areas that are not available for use by the general public. This apartment project (Group R-2) contains resident parking that consists of the following; 150 car open surface parking lot, 20 carports, and 20 garages beneath the building. The leasing office for the apartment project (on the site with the apartments) was constructed as a stand-alone building and has a separate visitor and employee parking lot for 10 cars. For the Group R-2 parking, per section 1106.2, item 1, 2%, but not less than 1, of each "type" of parking is required to be accessible. This yields a total of 5 accessible parking spaces; 3 accessible parking spaces for the open surface parking, 1 accessible parking space for the carport, and 1 accessible parking space for the garages beneath the building. For the visitor and employee parking lot, per section 1106.1 and table 1106.1, a minimum of 1 accessible parking space is required.

When it comes to determining the minimum number of required accessible parking spaces for vans, there are two

commonly used methods by jurisdictions:

Method 1. Combine the number of required or provided accessible parking spaces from both the Group R-2 and leasing office parking facilities and then divide this number by six to determine the required, minimum number of accessible parking spaces for vans.

5 accessible parking spaces (R-2) + 1 accessible parking space (leasing office) = 6 accessible parking spaces / 6 = minimum of 1, accessible parking space for vans, required.

At this point, the language in section 1106.5 does not identify where the single accessible parking space for the van would be located. It could be located either in the leasing office parking space or the R-2 parking areas. If the accessible parking space for the van is located only at the Group R-2 area, the parking at the leasing office area would be non-compliant with the provisions found in the 2010 ADA Standards for Accessible Design.

Method 2. Use the individual number of required or provided accessible parking spaces for each parking "facility" and divide this individual number by six to determine the required minimum number of accessible parking spaces for vans for each parking facility.

5 accessible parking spaces (R-2) / 6 = .833 = 1 accessible parking space for vans, required (R-2 parking facility)

1 accessible parking space (leasing office) / 6 = .167 = 1 accessible parking space for vans, required (leasing office parking facility)

The code language found in proposed section 1106.5.1, item 1, seeks to ensure that at a minimum, in situations where there are separate parking facilities serving multiple, varying occupancies (notably I-1, R-2, R-3, and R-4), an accessible van space will be provided where accessible parking is required that utilizes section 1106.1. This is aligned with the requirements found in the 2010 ADA Standards for Accessible Design. It should be noted that the proposed language exceeds the requirements found in the Fair Housing Act Guidelines because The Guidelines do not require that accessible van parking be provided at resident parking areas. However, in circumstances where the Group R-2, R-3, or R-4 occupancy are also subject to the Federal accessibility statutes, such as the ADA, the proposed language ensures that where multiple parking facilities serving multiple occupancies occur on one site, an accessible parking space for a van will be provided, aligning with the requirements found in the ADA.

Cost Impact

The code change proposal will not increase or decrease the cost of construction .

Whether the language of the code change proposal will increase or decrease the cost of construction depends upon how jurisdictions currently determine the minimum required number of accessible parking spaces for vans and their distribution. As the documentation for the code change proposal illustrates, currently there are two methods by which the minimum number of required accessible parking spaces for vans can be determined.

Where there are parking facilities for I-1, R-1, R-2, R-3, and R-4 occupancies combined with parking for other occupancies, the code change proposal may not necessarily increase or decrease the cost of construction as compliance with ADA requirements may potentially necessitate multiple locations for accessible parking spaces for vans.

Internal ID: 1632

E119-18

IBC: 1106.7 (New), Chapter 35

Proponent: Dawn Anderson, representing self (gonedawning@yahoo.com); Dan Buuck, representing National Association of Home Builders (dbuuck@nahb.org); David Collins, representing the American Institute of Architects (dcollins@preview-group.com); Marsha Mazz, representing U.S. Access Board (mazz@Access-Board.gov); Dominic Marinelli, representing United Spinal Association (DMarinelli@accessibility-services.com)

2018 International Building Code

Add new text as follows:

1106.7 Parking meters and pay stations. Where parking meters and pay stations serve accessible parking spaces, such parking meters and pay stations shall be accessible.

Update standard(s) as follows:

ICC

International Code Council, Inc.
500 New Jersey Ave NW 6th Floor
Washington DC 20001

US

ICC A117.1-092017:

Accessible and Usable Buildings and Facilities

Reason:

The 2017 ICC A117.1 will have requirements for accessibility to parking meters and pay stations. This scoping will clarify where those provisions should apply where parking meters and pay stations are provided in parking lots or parking garages on a site. To combat fraud and abuse of disabled parking privileges and to increase revenue, many jurisdictions such as Arlington, VA and Bethany Beach, DE are moving toward requiring people eligible to park in accessible spaces to pay for parking. See "Metered Parking Spaces" at <https://www.townofbethanybeach.com/399/Public-Parking---Pay-to-Park>. Information about accessible pay stations in the City of Raleigh, NC is at <https://www.raleighnc.gov/business/content/PWksParkingMgmt/Articles/UsingNewParkingMeters.html>.

Cost Impact

The code change proposal will increase the cost of construction .

The cost will be labor. Installers will need to take care to site parking meters and pay stations on accessible routes and to locate operable parts of equipment adjacent to clear floor space. Most parking meters on the market today are accessible when installed close to curb ramps, on an accessible route, and at a height (48" max.) allowing wheelchair users to approach and reach the controls. The revenue from the previously free parking spaces could mitigate the cost.

Analysis: The 2009 edition of the ICC A117.1 standard is referenced in Chapter 35.

Internal ID: 537

E120-18

IBC: 1106.8 (New)

Proponent: Jim Safranek, representing Safranek Group LLC (info@safranekgroup.com)

2018 International Building Code

Add new text as follows:

1106.8 Electrical vehicle charging stations. Where electrical vehicle charging stations are provided, at least 5 percent of the electrical vehicle charging stations provided shall be accessible. Where multiple types of electrical vehicle charging stations are provided, not less than one of each type of electrical vehicle charging station shall be accessible.

Reason:

The 2017 edition of ICC A117.1 now includes technical requirements for accessible electrical vehicle charging stations. Where the 2017 edition of ICCA117.1 is utilized as the accessibility standard for the edition of the International Building Code (IBC), Chapter 11 of the IBC must have scoping provisions identifying where and how many accessible electrical vehicle charging stations must be provided. The proposed code change attempts to scope the minimum number and location for accessible electrical vehicle charging stations.

Cost Impact

The code change proposal will not increase or decrease the cost of construction .

Where the 2017 edition of ICC A117 is required to be used, scoping for electrical vehicle charging stations must be provided within the International Building Code in Chapter 11.

Internal ID: 2008

E121-18

IBC: 202 (New), 406.2.7, 1106.1 (New), 1107 (New), 1107.1 (New), 1107.2 (New), 1107.2.1 (New), 1107.2.2 (New), 1109.14, Chapter 35

Proponent: Dawn Anderson, representing self (gonedawning@yahoo.com); Dan Buuck, representing National Association of Home Builders (dbuuck@nahb.org); David Collins, representing the American Institute of Architects (dcollins@preview-group.com); Marsha Mazz, representing U.S. Access Board (mazz@Access-Board.gov); Dominic Marinelli, representing United Spinal Association (DMarinelli@accessibility-services.com)

2018 International Building Code

SECTION 202 DEFINITIONS

Add new definition as follows:

ELECTRIC VEHICLE CHARGING STATION. One or more vehicle spaces served by an electric vehicle charging system.

Revise as follows:

406.2.7 Electric vehicle charging ~~stations~~systems. Where provided, electric vehicle charging ~~stations~~systems shall be installed in accordance with NFPA 70. Electric vehicle charging system equipment shall be listed and labeled in accordance with UL 2202. Electric vehicle supply equipment shall be listed and labeled in accordance with UL 2594. Accessibility to electric vehicle charging stations shall be provided in accordance with Chapter 11.

SECTION 1106 PARKING AND PASSENGER LOADING FACILITIES

Add new text as follows:

1106.1 General. Parking shall comply with Section 1106.2 through 1106.7. Passenger loading zones shall comply with Section 1106.8.

1107 MOTOR VEHICLE RELATED FACILITIES

1107.1 General. Electrical vehicle charging stations shall comply with Section 1107.2. Fuel-dispensing systems shall comply with Section 1107.3.

1107.2 Electrical vehicle charging stations. . Electrical vehicle charging stations shall comply with Sections 1107.2.1 and 1107.2.2.

Exception: Electrical vehicle charging stations provided to serve Groups R-2, R-3 and R-4 occupancies are not required to comply with this section.

1107.2.1 Number of accessible vehicle spaces. At least five percent (5%) of vehicle spaces on the site served by electrical vehicle charging systems but, not fewer than one for each type of electric vehicle charging system shall be accessible.

1107.2.2 Vehicle space size. . Accessible vehicle spaces shall comply with the requirements for a van accessible parking space that is 132 inches (3350 mm) minimum in width with an adjoining access aisle that is 60 inches (1525 mm) minimum in width.

Revise as follows:

~~1109.14~~**1107.3 Fuel-dispensing systems.** Fuel-dispensing systems shall be *accessible*.

Update standard(s) as follows:

ICC

International Code Council, Inc.
500 New Jersey Ave NW 6th Floor
Washington DC 20001

US

ICC A117.1-~~09~~2017:

Accessible and Usable Buildings and Facilities

Reason:

IBC Section 406.7 requires that "Accessibility to electric vehicle charging stations (EVCS) shall be provided in accordance with Chapter 11". However, Chapter 11 does not contain specific scoping to address these EVCS. This proposal seeks to provide some detail in Chapter 11 to address that shortfall.

Section 1106.1 provides a charging statement for parking and passenger loading zones, which was missing in the current code.

This proposal creates a new Section 1107 to deal with motor vehicle related facilities. This will provide new requirements for electrical vehicle charging stations and retains the current requirements for fuel-dispensing systems.

Section 1107.2 is a general scoping statement for EVCS.

The exception refers to R-2 occupancies. This is due to the way these function. If a person gets an EV and elects to install an EVCS at their designated parking space, that should not trigger the requirement since it is occupant specific.

Section 1107.2.1 addresses the number of space. It does not mandate EVCS. It acknowledges that where EVCS are provided a portion must be accessible. A factor of five percent (5%) was used based on similar thresholds for other types of amenities like lockers, dressing rooms, bowling lanes, sinks, etc. It is also important to note that this is based on the number of EVCS provided on the site. This is a minimal requirement. Rather than address it by cluster of EVCS, such as could happen on a campus, this begins at a very low requirement. If it proves insufficient, it can be adjusted at a later date. It also requires at least one accessible EVCS for each type of charger. There are currently two common types of charging equipment. If one space can be served by both types, that would comply. But, it makes sure that they will both be accessible.

Section 1107.2.2 prescribes the requirements for the charging space. By making a reference to the van accessible parking space and designating the size, the other aspects of the space such as slope, marking, etc. as found in ICC A117.1 (Section 502) will be included.

The 2017 edition of the ICC A117.1 Standard does not contain any scoping and does not include any specific requirements for the space where charging will happen. The provisions in the A117.1 (Section 502.11) address operable parts, an accessible route from the access aisle to the charging equipment, and criteria on what to do with potential obstructions.

Cost Impact

The code change proposal will increase the cost of construction .

EVCS are not required. However, IBC Section 406.7 currently requires them to be accessible, but fails to provide technical specifications. If provided, this may require additional width at a small percentage of the spaces at those charging stations.

Analysis: The 2009 edition of the ICC A117.1 standard is referenced in Chapter 35.

Internal ID: 538

E122-18

IBC: 1107.5.1.1

Proponent: Gregory Nicholls, The PREVIEW Group, Inc., representing The American Institute of Architects (gnicholls@preview-group.com)

2018 International Building Code

Revise as follows:

1107.5.1.1 Accessible units. In Group I-1, Condition 1, at least 4 percent, but not less than one, of the *dwelling units* and *sleeping units* shall be *Accessible units*. In Group I-1, Condition 2, at least 10 percent, but not less than one, of the *dwelling units* and *sleeping units* shall be *Accessible units*. Accessible dwelling units and sleeping units shall be dispersed among the various classes of units.

Reason:

This proposal seeks to make all classes of sleeping and dwelling units in Group I-1 occupancies available to the disable community. The proposed text being added matches the dispersal language in Section 1107.6.1.1 for Group R-1 and Section 1107.6.2.2.1 2018 IBC. The designs for Group I-1 facilities often have varying numbers of bedrooms and/or communicating units to facilitate the situations for those couples or families that have varying care requirements but want to remain close. Modifications are limited in these facilities, as the patients and clients are renting the space, similar to Group R-1's. Also, the difference in the degree of accessibility is more drastic between the Accessible units required for Group I-1 and the remaining Type B units than it is for Type A units and Type B units in Group R-2.

The Advisory to Section 223.1 of the 2010 Standards for Construction for Long-Term Care Facilities addresses this as well by noting, "While dispersion is not required, the flexibility it provides can be a critical factor in ensuring cost effective compliance with applicable civil rights laws, including Titles II and III of the ADA and Section 504 of the Rehabilitation Act of 1973, as amended. Additionally, all types of features and amenities should be dispersed among accessible sleeping rooms to ensure equal access to and a variety of choices for all patients and residents."

This proposal takes in what is already a part of the IBC for Groups R-1 and R-2 for dispersal of the Accessible and Type A units and the advisory text in the 2010 ADA Standards for Construction and provides an appropriate and necessary capacity for those with disabled persons in their families and/or relationships to have choices for in they choose to live as do those without physical disabilities.

Bibliography:

2010 ADA Standards for Accessible Design, Dept of Justice

Cost Impact

The code change proposal will increase the cost of construction .

The cost increase will be very minimal, as this proposal does not increase the number of Accessible units, only their variety. The only increase then, would be if this meant the designer had to provide larger units that are Accessible.

Internal ID: 1268

E123-18

IBC: 1107.5, 1107.5.1, 1107.5.1.1, 1107.5.1.2 (New)

Proponent: John Williams, Chair, representing Healthcare Committee (AHC@iccsafe.org)

2018 International Building Code

1107.5 Group I. *Accessible units* and *Type B units* shall be provided in Group I occupancies in accordance with Sections 1107.5.1 through 1107.5.5.

Revise as follows:

1107.5.1 Group I-1. *Accessible units* and *Type B units* shall be provided in Group I-1 occupancies in accordance with Sections 1107.5.1.1 and ~~1107.5.1.2~~ through 1107.5.1.3.

1107.5.1.1 Accessible units—units in Group I-1, Condition 1. In Group I-1, Condition 1, at least 4 percent, but not less than one, of the *dwelling units* and *sleeping units* shall be *Accessible units*. ~~In Group I-1, Condition 2, at least 10 percent, but not less than one, of the *dwelling units* and *sleeping units* shall be *Accessible units*.~~

Exceptions:

1. In not more than 50 percent of the Accessible units, water closets shall not be required to comply with ICC A117.1 where such water closets comply with Section 1109.2.2.
2. In not more than 50 percent of the Accessible units, roll-in-type showers shall not be required to comply with ICC A117.1 where roll-in-type showers comply with Section 1109.2.3.

Add new text as follows:

1107.5.1.2 Accessible units in Group I-1, Condition 2. In Group I-1, Condition 2, at least 10 percent, but not less than one, of the *dwelling units* and *sleeping units* shall be *Accessible units*.

Exceptions:

1. In not more than 50 percent of the Accessible units, water closets shall not be required to comply with ICC A117.1 where such water closets comply with Section 1109.2.2.
2. In not more than 50 percent of the Accessible units, roll-in-type showers shall not be required to comply with ICC A117.1 where roll-in-type showers comply with Section 1109.2.3.

Revise as follows:

~~1107.5.1.2~~**1107.5.1.3 Type B units.** In structures with four or more *dwelling units* or *sleeping units intended to be occupied as a residence*, every *dwelling unit* and *sleeping unit intended to be occupied as a residence* shall be a *Type B unit*.

Exception: The number of *Type B units* is permitted to be reduced in accordance with Section 1107.7.

Reason:

This is a part of a series of proposals for both scoping and technical criteria to allow for assisted toileting and bathing in some types of care facilities.

Group I-1 facilities are the first step for housing for persons who need assistance including custodial care. The code should recognize that older adults have limited upper body strength. Allowing for half of the Accessible units to use the assisted toileting and bathing, allows for options within the facility.

It should be noted that the assisted toileting arrangement would be permitted for the Type B units with current A117.1 text. This option would exceed requirements for the Fair Housing Act Guideline.

This proposal is submitted by the ICC Committee on Healthcare (CHC). The CHC was established by the ICC Board to evaluate and assess contemporary code issues relating to healthcare facilities. This is a joint effort between ICC and the American Society for Healthcare Engineering (ASHE), a subsidiary of the American Hospital Association, to eliminate duplication and conflicts in healthcare regulation. In 2017 the CHC held 2 open meetings and numerous conference calls, which included members of the committees as well as any interested parties, to discuss and debate the proposed changes. Information on the CHC, including: meeting agendas; minutes; reports; resource documents; presentations; and all other materials developed in conjunction with the CHC effort can be downloaded from the CHC website at: <https://www.iccsafe.org/codes-tech-support/cs/icc-committee-on-healthcare/>.

Cost Impact

The code change proposal will increase the cost of construction .

If someone chooses this option, there would be an increase in bathroom size for the water closet and a situation where someone did a roll-in instead of a transfer shower.

Internal ID: 702

E124-18

IBC: 1107.5.2, 1107.5.2.1, 1107.5.2.2

Proponent: John Williams, Chair, representing Healthcare Committee (AHC@iccsafe.org)

2018 International Building Code

Revise as follows:

1107.5.2 Group I-2 nursing homes. *Accessible units* and *Type B units* shall be provided in nursing homes of Group I-2, Condition 1 occupancies in accordance with Sections 1107.5.2.1 and 1107.5.2.2.

1107.5.2.1 Accessible units. At least 50 percent but not less than one of each type of the *dwelling units* and *sleeping units* shall be *Accessible units*.

Exceptions:

1. In not more than 90 percent of the Accessible units, water closets shall not be required to comply with ICC A117.1 where such water closets comply with Section 1109.2.2.
2. In not more than 90 percent of the Accessible units, roll-in-type showers shall not be required to comply with ICC A117.1 where roll-in-type showers comply with Section 1109.2.3.

1107.5.2.2 Type B units. In structures with four or more *dwelling units* or *sleeping units* intended to be occupied as a residence, every *dwelling unit* and *sleeping unit* intended to be occupied as a residence shall be a *Type B unit*.

Exception: The number of *Type B units* is permitted to be reduced in accordance with Section 1107.7.

Reason:

This is a part of a series of proposals for both scoping and technical criteria to allow for assisted toileting and bathing in some types of care facilities.

Group I-2 nursing home facilities are the second step for housing for persons who need assistance including medical care. The code should recognize that older adults have limited upper body strength. Allowing for 90 of the Accessible units to use the assisted toileting and bathing, allows for options within the facility.

It should be noted that the assisted toileting arrangement would be permitted for the Type B units with current A117.1 text. This option would exceed requirements for the Fair Housing Act Guideline.

This proposal is submitted by the ICC Committee on Healthcare (CHC). The CHC was established by the ICC Board to evaluate and assess contemporary code issues relating to healthcare facilities. This is a joint effort between ICC and the American Society for Healthcare Engineering (ASHE), a subsidiary of the American Hospital Association, to eliminate duplication and conflicts in healthcare regulation. In 2017 the CHC held 2 open meetings and numerous conference calls, which included members of the committees as well as any interested parties, to discuss and debate the proposed changes. Information on the CHC, including: meeting agendas; minutes; reports; resource documents; presentations; and all other materials developed in conjunction with the CHC effort can be downloaded from the CHC website at: <https://www.iccsafe.org/codes-tech-support/cs/icc-committee-on-healthcare/>.

Cost Impact

The code change proposal will increase the cost of construction .

If someone chooses this option, here would be an increase in bathroom size for the water closet and a situation where someone did a roll-in instead of a transfer shower.

Internal ID: 703

E125-18

IBC: 1107.5.4

Proponent: John Williams, Chair, representing Healthcare Committee (AHC@iccsafe.org)

2018 International Building Code

Revise as follows:

1107.5.4 Group I-2 rehabilitation facilities. In hospitals and rehabilitation facilities of Group I-2 occupancies that specialize in treating conditions that affect mobility, or units within either that specialize in treating conditions that affect mobility, 100 percent of the *dwelling units* and *sleeping units* shall be *Accessible units*.

Exceptions:

1. In not more than 50 percent of the Accessible units, water closets shall not be required to comply with ICC A 117.1 where such water closets comply with Section 1109.2.2.
2. In not more than 50 percent of the Accessible units, roll-in-type showers shall not be required to comply with ICC A117.1 where roll-in-type showers comply with Section 1109.2.3.

Reason:

This is a part of a series of proposals for both scoping and technical criteria to allow for assisted toileting and bathing in some types of care facilities.

Group I-2 rehabilitation hospital facilities are housing for persons who need assistance including medical care. The code should recognize that older adults have limited upper body strength. Allowing for 50 of the Accessible units to use the assisted toileting and bathing, allows for options within the facility.

This proposal is submitted by the ICC Committee on Healthcare (CHC). The CHC was established by the ICC Board to evaluate and assess contemporary code issues relating to healthcare facilities. This is a joint effort between ICC and the American Society for Healthcare Engineering (ASHE), a subsidiary of the American Hospital Association, to eliminate duplication and conflicts in healthcare regulation. In 2017 the CHC held 2 open meetings and numerous conference calls, which included members of the committees as well as any interested parties, to discuss and debate the proposed changes. Information on the CHC, including: meeting agendas; minutes; reports; resource documents; presentations; and all other materials developed in conjunction with the CHC effort can be downloaded from the CHC website at: <https://www.iccsafe.org/codes-tech-support/cs/icc-committee-on-healthcare/>.

Cost Impact

The code change proposal will increase the cost of construction .

If someone chooses this option, here would be an increase in bathroom size for the water closet and a situation where someone did a roll-in instead of a transfer shower.

Internal ID: 704

E126-18

IBC: 1107.7.2

Proponent: Jim Safranek, representing Safranek Group LLC

2018 International Building Code

Revise as follows:

1107.7.2 Multistory units. *A multistory dwelling unit or sleeping unit that is not provided with elevator service is not required to be a Type A unit or a Type B unit. Where a *multistory unit* is provided with external elevator service to only one floor, the floor provided with elevator service shall be the primary entry to the unit, shall comply with the requirements for a Type A units or Type B unit, where applicable and, where provided within the unit, a living area, a kitchen and a toilet facility shall be provided on that floor.*

Reason:

Purpose: One type of Group R-2 multi-family residential project seen in several areas of the United States are apartment buildings consisting solely of multiple, stacked, two-level multistory dwelling units (upper units placed above lower units) using a common-use building stair to access the upper units, instead of using a common-use elevator.

For this type of building, per section 1107.7.2 of the 2018 IBC, the individual multistory dwelling units are not required to be Type 'B' units. Therefore, an apartment project consisting solely of a building (or buildings) containing these type of units would not have any Type 'B' units and initially would appear to be exempt from any accessibility requirements. However, section 1107.6.2.2.1 of the 2018 IBC would require that a Type 'A' unit be provided, regardless of the fact that the project did not contain any Type 'B' units. The result of this is a project that did not contain any Type 'B' units and initially appeared to be exempt from any accessibility requirements would be required to provide Type 'A' units and all common-use areas that were initially exempt from accessibility requirements would now be required to comply with applicable accessibility requirements. The purpose of this proposal is to clarify the requirements for Type 'A' units for Group R-2 projects consisting solely of multistory dwelling units without elevator service.

Reason and Substantiation: Where Exception 1 of section 1107.6.2.2.1 permits the number of Type 'A' units to be reduced per section 1107.7, subsection 1107.7.1 (Structures without elevator service), does not address the possibility of multi-level dwelling units in a structure without elevator service. The result of this is that the requirements found in section 1107.7.1 and its subsections, 1107.7.1.1 and 1107.7.1.2 yield units that are classified as Type 'B' units. Additionally, section 1107.7.2 (Multistory units) does identify that a multistory dwelling or sleeping unit not provided with elevator service is not required to be a Type 'B' unit, which mirrors the requirements found in the Fair Housing Act. Section 1107.7.2 also states that a multistory unit with an external elevator service to one floor is required to have the floor of that unit meet Type 'B' requirements. Unfortunately, section 1107.7.2 does not have language such as that found in section 1107.7.1 ("The number of Type 'A' units shall be determined in accordance with Section 1107.6.2.2.1.") stating how the number of Type 'A' units are determined where multi-level dwelling units occur. Given the lack of any specific requirement clarifying how Type 'A' units are determined for multistory units, the general requirement found in section 1107.6.2.2.1 is then applicable and all multistory units, regardless of whether they have a floor required to comply with Type 'B' requirements, or not (in the case of multistory units without elevator service) are utilized when determining the number of Type 'A' units for a project. This will result in all projects with multistory units being required to have Type 'A' units.

For any Group R-2 project (except those with certain grade conditions and those with nonelevator buildings where certain design flood elevation conditions exist) Type 'B' units will always occur and Type 'A' units will always be required. Given this, it appears overly restrictive that the International Building Code (IBC) require that Type 'A' units and their corresponding accessible common-use areas be provided where Type 'B' units and accessible common-use areas are not required, as is the case for R-2 projects that consist solely of stacked multistory dwelling units without any type of elevator service. Additionally, this requirement for Type 'A' units where Type 'B' units are not provided, greatly exceeds the accessibility requirements found in the Fair Housing Act (FHA). For a project consisting solely of multistory dwelling units without elevator service, the multistory dwelling units as well as their accompanying common-use areas would not be required to comply with the accessibility requirements found in the FHA. While some accessibility requirements found in the IBC and its accompanying accessibility standard ICC A117.1 exceed the requirements found in the FHA, in this circumstance, the IBC would greatly exceed the FHA requirements.

The proposed addition to section 1107.7.2 attempts to address this issue by eliminating the requirement for Type 'A' units at Group R-2 projects where only multistory dwelling units without any type of elevator service are provided.

Cost Impact

The code change proposal will decrease the cost of construction .

For multi-family residential projects that consist solely of multistory dwelling units, there will be a reduction in costs

where Type 'A' units and accessible common-use areas are not required.

Internal ID: 1584

E127-18

IBC: 1107.7.5

Proponent: Gregory Wilson, representing Federal Emergency Management Agency (gregory.wilson2@fema.dhs.gov); David Collins, The American Institute of Architects, representing The American Institute of Architects (dcollins@preview-group.com)

2018 International Building Code

Revise as follows:

1107.7.5 ~~Design flood elevation.~~Flood hazard areas. ~~The required number of Type A units and Type B units shall not apply to a site where the~~ shall not be required for buildings without elevator service that are located in flood hazard areas as established in Section 1612.3, where the minimum required elevation of the lowest floor or the lowest horizontal structural building members of nonelevator buildings are at or above the *design flood elevation* resulting supporting horizontal structural member, as applicable, results in all of the following:

1. A difference in elevation between the minimum required floor elevation at the primary entrances and vehicular and pedestrian arrival points within 50 feet (15 240 mm) exceeding 30 inches (762 mm).
2. A slope exceeding 10 percent between the minimum required floor elevation at the primary entrances and vehicular and pedestrian arrival points within 50 feet (15 240 mm).

Where such arrival points are not within 50 feet (15 240 mm) of the primary entrances, the closest arrival points shall be used.

Reason:

This proposal makes the provision easier to read and also makes it consistent with terms used in this code and reference standard ASCE 24-14, Flood Resistant Design and Construction. The purpose of this section is that if, based on the required floor elevation, the listed criteria are met, then an accessible route to the units is deemed not feasible. The original language of this section is from a legacy code (likely BOCA).

This proposal changes the elevation reference point from the design flood elevation to the minimum required lowest floor elevation of the building, which is specified in Sec. 1612, by reference to ASCE 24-14. For Flood Design Class 2 buildings, which includes multi-family buildings, the minimum required lowest floor elevation is the base flood elevation plus one foot. Therefore, the required lowest floor elevation should be used to apply the test specified in the number items.

Cost Impact

The code change proposal will not increase or decrease the cost of construction .

No additional cost. This proposal does not increase construction requirements or costs.

Internal ID: 1141

E128-18

IBC: 1109.2, 1109.2.2 (New), 1109.2.2.1 (New), 1109.2.2.2 (New), 1109.2.2.2.1 (New), 1109.2.2.2.2 (New), 1109.2.2.2.3 (New), 1109.2.2.3 (New), 1109.2.2.4 (New), 1109.2.2.5 (New), 1109.2.2.6 (New)

Proponent: John Williams, Chair, representing Healthcare Committee (AHC@iccsafe.org)

2018 International Building Code

Revise as follows:

1109.2 Toilet and bathing facilities. Each toilet room and bathing room shall be *accessible*. Where a floor level is not required to be connected by an *accessible route*, the only toilet rooms or bathing rooms provided within the facility shall not be located on the inaccessible floor. Except as provided for in Sections ~~1109.2.2-1109.2.3~~ and ~~1109.2.3-1109.2.4~~, at least one of each type of fixture, element, control or dispenser in each accessible toilet room and bathing room shall be *accessible*.

Exceptions:

1. Toilet rooms or bathing rooms accessed only through a private office, not for *common* or *public use* and intended for use by a single occupant, shall be permitted to comply with the specific exceptions in ICC A117.1.
2. This section is not applicable to toilet and bathing rooms that serve *dwelling units* or *sleeping units* that are not required to be *accessible* by Section 1107.
3. Where multiple single-user toilet rooms or bathing rooms are clustered at a single location, at least 50 percent but not less than one room for each use at each cluster shall be *accessible*.
4. Where no more than one urinal is provided in a toilet room or bathing room, the urinal is not required to be *accessible*.
5. Toilet rooms or bathing rooms that are part of critical care or intensive care patient sleeping rooms serving *Accessible units* are not required to be *accessible*.
6. Toilet rooms or bathing rooms designed for bariatrics patients are not required to comply with the toilet room and bathing room requirement in ICC A117.1. The *sleeping units* served by bariatrics toilet or bathing rooms shall not count toward the required number of *Accessible sleeping units*.
7. Where permitted in Section 1107, in toilet rooms or bathrooms serving Accessible units, water closets designed for assisted toileting shall comply with Sections 1109.2.2.
8. Where toilet facilities are primarily for children's use, required *accessible* water closets, toilet compartments and lavatories shall be permitted to comply with children's provision of ICC A117.1.

Add new text as follows:

1109.2.2 Water closets designed for assisted toileting. Water closets designed for assisted toileting shall comply with Section 1109.2.2.1 through 1109.2.2.6.

1109.2.2.1 Location. The centerline of the water closet shall be 24 inches (610 mm) minimum and 26 inches maximum (660 mm) from one side of the required clearance.

1109.2.2.2 Clearance. Clearance around the water closet shall comply with Section 1109.2.2.2.1 through 1109.2.2.2.3

1109.2.2.2.1 Clearance width. Clearance around a water closet shall be 66 inches (1675 mm) minimum in width, measured perpendicular from the side of the clearance that is 24 inches (610 mm) minimum and 26 inches (660 mm) maximum from the water closet centerline.

1109.2.2.2.2 Clearance depth. Clearance around the water closet shall be 78 inches (1980 mm) minimum in depth, measured perpendicular from the rear wall

1109.2.2.2.3 Clearance overlap. The required clearance around the water closet shall be permitted overlaps per ICC A117.1 Section 604.3.3

1109.2.2.3 Height. The height of the water closet seats shall comply with ICC A117.1 Section 604.4.

1109.2.2.4 Swing-up grab bars. The swing-up grab bars shall comply with ICC A117.1 Sections 609.2 and 609.8. Swing-up grab bars shall be provided on both sides of the water closet and shall comply with all of the following:

1. The centerline of the grab bar shall be 14 inches minimum to 16 inches (356 to 405 mm) maximum from the centerline of the water closet
2. The length of the grab bar is 36 inches (915 mm) minimum in length, measured from the rear wall to the end of the grab bar.
3. The top of the grab bar in the down position is 30 inches (760 mm) minimum and 34 inches (865 mm) maximum above the floor.

1109.2.2.5 Flush controls. Flush controls shall comply with ICC A117.1 Section 604.6.

1109.2.2.6 Dispensers. Toilet paper dispensers shall be mounted on at least one of the swing-up grab bars and the outlet of the dispenser shall be located at 24 inches (610 mm) minimum to 36 inches (915 mm) maximum from the rear wall.

Reason:

This is a part of a series of proposals for both scoping and technical criteria to allow for assisted toileting and bathing in some types of care facilities. We are asking for this technical criteria to be added into the IBC at this time due to the timing for the next edition of the ICC A117.1 - probably not referenced until the 2024 or 2027 code cycle. The format follows the ICC A117.1 for water closets for clarity and easy comparison of requirements.

In our educated opinion, these technical criteria will provide equivalent facilitation to the accessible toilet requirement in ICC A117.1 and the 2010 ADA Standard. These requirements are for toilets used by older adults or persons with limited upper body strength in care settings and where care-givers assist residents. It provides additional space between the toilet and any obstructions, such as a lavatory, cabinet or wall. Additional space is provided in front of a toilet to allow for additional approach options. Clear floor space for an unassisted side transfer is provided as well, consistent with 2010 ADA and A117.1. The provisions allow the use of fold-down grab bars in lieu of wall-mounted grab bars.

The code needs to recognize that older adults have limited upper body strength and while they do need assistance (grab bars) when transferring on/off the toilet the standard grab bar configuration does not work for them. Research has proven that the use of fold-down grab bars on both sides of the toilet is safer and easier for older adults who transfer independently. In addition, residents in care settings who need staff assistance to transfer on/off the toilet need more space between the toilet and the wall to enable a staff person (or two) to fully assist a person without risk of injury to the caregiver. In addition, the additional space at the toilet also allows for better access with a lifting device.

The Mayer-Rothschild Foundation has completed research that gives ideal dimensions for grab bars and toilet spacing. The research was completed too late to be considered for inclusion in the most recent ICC A117.1. Adding this into the IBC at this time is needed by the industry to provide adequate patient care and limit risks for this population and staff. The intent is to propose these technical provisions to the next A117.1 - the earliest of which could be the 2022, with a reference in the 2024 codes.

This information was presented to the U.S. Access Board in early 2017. They supported the idea, but at this time the U.S. Access Board cannot move forward with any new federal rules at this time due to federal budgetary limitation.

For additional information on the research see: <http://ideasinstitute.org/publications.asp>

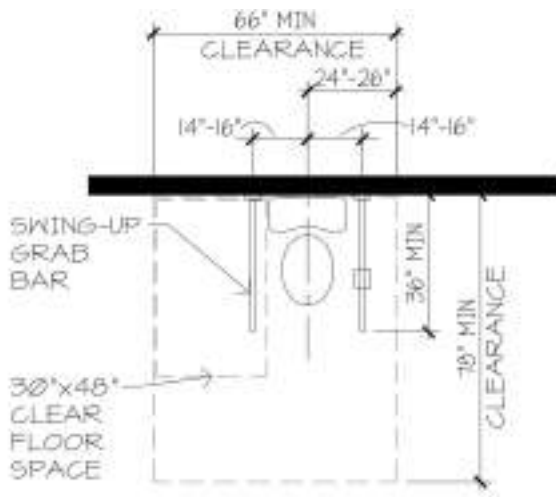

ALTERNATE WATER CLOSET

This proposal is submitted by the ICC Committee on Healthcare (CHC). The CHC was established by the ICC Board to evaluate and assess contemporary code issues relating to healthcare facilities. This is a joint effort between ICC and the American Society for Healthcare Engineering (ASHE), a subsidiary of the American Hospital Association, to eliminate duplication and conflicts in healthcare regulation. In 2017 the CHC held 2 open meetings and numerous conference calls, which included members of the committees as well as any interested parties, to discuss and debate the proposed changes. Information on the CHC, including: meeting agendas; minutes; reports; resource documents; presentations; and all other materials developed in conjunction with the CHC effort can be downloaded from the CHC website at: <https://www.iccsafe.org/codes-tech-support/cs/icc-committee-on-healthcare/>.

Bibliography:

Lee, S.J., Sanford, J., Calkins, M. Meglen, S., Endicott, S. & Phillips, A. (2017) Beyond ADA accessibility: Meeting seniors' needs for toilet transfers. HERD. DOI: 10.1177/1937586717730338

Cost Impact

The code change proposal will increase the cost of construction .

There cost for the two grab bars should be similar. There is some additional clear floor space around the toilet to allow for assistance by staff.

Internal ID: 700

E129-18

IBC: 1109.2, 1109.2.3 (New), 1109.2.3.1 (New), 1109.2.3.2 (New), 1109.2.3.3 (New), 1109.2.3.3.1 (New), 1109.2.3.3.2 (New), 1109.2.3.4 (New), 1109.2.3.5 (New), 1109.2.3.6 (New), 1109.2.3.7 (New), 1109.2.3.8 (New), 1109.2.3.9 (New)

Proponent: John Williams, Chair, representing Healthcare Committee (AHC@iccsafe.org)

2018 International Building Code

Revise as follows:

1109.2 Toilet and bathing facilities. Each toilet room and bathing room shall be *accessible*. Where a floor level is not required to be connected by an *accessible route*, the only toilet rooms or bathing rooms provided within the facility shall not be located on the inaccessible floor. Except as provided for in Sections ~~1109.2.2-1109.2.4~~ and ~~1109.2.3-1109.2.5~~, at least one of each type of fixture, element, control or dispenser in each accessible toilet room and bathing room shall be *accessible*.

Exceptions:

1. Toilet rooms or bathing rooms accessed only through a private office, not for *common* or *public use* and intended for use by a single occupant, shall be permitted to comply with the specific exceptions in ICC A117.1.
2. This section is not applicable to toilet and bathing rooms that serve *dwelling units* or *sleeping units* that are not required to be *accessible* by Section 1107.
3. Where multiple single-user toilet rooms or bathing rooms are clustered at a single location, at least 50 percent but not less than one room for each use at each cluster shall be *accessible*.
4. Where no more than one urinal is provided in a toilet room or bathing room, the urinal is not required to be *accessible*.
5. Toilet rooms or bathing rooms that are part of critical care or intensive care patient sleeping rooms serving *Accessible units* are not required to be *accessible*.
6. Toilet rooms or bathing rooms designed for bariatrics patients are not required to comply with the toilet room and bathing room requirement in ICC A117.1. The *sleeping units* served by bariatrics toilet or bathing rooms shall not count toward the required number of *Accessible sleeping units*.
7. Where permitted in Section 1107, in bathrooms serving Accessible units, showers designed for assisted toileting shall comply with Section 1109.2.3.
8. Where toilet facilities are primarily for children's use, required *accessible* water closets, toilet compartments and lavatories shall be permitted to comply with children's provision of ICC A117.1.

Add new text as follows:

1109.2.3 Standard roll-in-type shower compartment designed for assisted bathing. Standard roll-in-type shower compartments designed for assisted bathing shall comply with Section 1109.2.3.1 through 1109.2.3.8.

1109.2.3.1 Size. Standard roll-in-type shower compartments shall have a clear inside dimension of 60 inches (1525 mm) minimum in width and 30 inches (760 mm) minimum in depth, measured at the center point of opposing sides. An entry 60 inches (1525 mm) minimum in width shall be provided.

1109.2.3.2 Clearance. A clearance of 60 inches (1525 mm) minimum in length adjacent to the 60-inch (1525 mm) width of the open face of the shower compartment, and 30 inches (760 mm) minimum in depth, shall be provided.

Exceptions:

1. A lavatory complying with Section 606 shall be permitted at one end of the clearance.
2. Where the shower compartment exceeds minimum sizes, the clear floor space shall be placed adjacent to the grab bars and 30 inches minimum from the back wall.

1109.2.3.3 Grab bars. Grab bars shall comply with ICC Section 609 and shall be provided in accordance with Section 1109.2.3.3.1 and 1109.2.3.3.2. In standard roll-in type shower compartments, grab bars shall be provided on three walls. Where multiple grab bars are used, required horizontal grab bars shall be installed at the same height above the floor.

Grab bars can be separate bars or one continuous bar.

1109.2.3.3.1 Back-wall grab bar. The back-wall grab bar shall extend the length of the back wall and extend within 6 inches (150 mm) maximum from the two adjacent side walls.

Exception:The back wall grab bar shall not be required to exceed 48 inches (1220 mm) in length. The rear grab bar shall be located with one end within 6 inches maximum of a side wall with a grab bar complying with Section 1109.2.3.3.2.

1109.2.3.3.2 Side-wall grab bars. The side wall grab bars shall extend the length of the wall and extend within 6 inches (150 mm) maximum from the adjacent back wall.

Exceptions:

1. The side-wall grab bar shall not be required to exceed 30 inches (760 mm) in length. The side grab bar shall be located with one end within 6 inches maximum of the back wall with a grab bar complying with Section 1109.2.3.3.1.
2. Where the side walls are located 72 inches (1830 mm) or greater apart, a grab bar is not required on one of the side-walls.

1109.2.3.4 Seats. Wall-mounted folding seats shall not be installed.

1109.2.3.5 Controls and hand showers. In standard roll-in-type showers, the controls and hand shower shall be located 38 inches (965 mm) minimum and 48 inches (1220 mm) maximum above the shower floor. Controls shall be located to facilitate caregiver access.

1109.2.3.6 Hand showers. Hand showers shall comply with ICC A117.1 Section 608.5.

1109.2.3.7 Thresholds. Thresholds shall comply with ICC A117.1 Section 608.6.

1109.2.3.8 Shower enclosures. Shower compartment enclosures for shower compartments shall comply with ICC A117.1 Section 608.7.

1109.2.3.9 Water temperature. Water temperature shall comply with ICC A117.1 Section 608.8.

Reason:

This is a part of a series of proposals for both scoping and technical criteria to allow for assisted toileting and bathing in some types of care facilities. We are asking for this technical criteria to be added into the IBC at this time due to the timing for the next edition of the ICC A117.1 - probably not referenced until the 2024 or 2027 code cycle. The format follows the ICC A117.1 for roll-in showers for clarity and easy comparison of requirements.

In our educated opinion, these technical criteria will provide equivalent facilitation to the accessible bathing requirement in ICC A117.1 and the 2010 ADA Standard. These requirements are for showers used by older adults or persons with limited upper body strength in care settings and where care-givers assist residents.

The key part of this change is to remove the requirement for permanently installed folding or fixed seats. These wall-mounted seats do not work well when residents are being assisted with showering. The wall mounted seats make it challenging for care-givers to access the back and one side of the resident they are bathing. Most often, if residents cannot stand for bathing, a portable, rolling chair is used and the folding seat stays folded up (but takes up space). This allows the care-giver greater access to all sides of the resident. In addition, the rolling chair is often easier to transfer to for older adults, than a wall mounted seat.

This proposal also recognizes alternate shower configurations that provide equal, if not better accessibility. For example, many nursing homes provide a "European" shower where two sides are open to the bathroom. This provides greater access for both resident with mobility issues as well as the care-giver. Water can be managed with shower curtains, either on a curtain track or an "L-shaped" curtain rod, however usually the entire room is designed to be a "wet room".

This information was presented to the U.S. Access Board in early 2017. They supported the idea, but at this time the U.S. Access Board cannot move forward with any new federal rules at this time due to federal budgetary limitation.

This proposal is submitted by the ICC Committee on Healthcare (CHC). The CHC was established by the ICC Board to evaluate and assess contemporary code issues relating to healthcare facilities. This is a joint effort between ICC and the American Society for Healthcare Engineering (ASHE), a subsidiary of the American Hospital Association, to eliminate

duplication and conflicts in healthcare regulation. In 2017 the CHC held 2 open meetings and numerous conference calls, which included members of the committees as well as any interested parties, to discuss and debate the proposed changes. Information on the CHC, including: meeting agendas; minutes; reports; resource documents; presentations; and all other materials developed in conjunction with the CHC effort can be downloaded from the CHC website at: <https://www.iccsafe.org/codes-tech-support/cs/icc-committee-on-healthcare/>.

For additional information on the research please go to: <http://ideasinstitute.org/publications.asp>

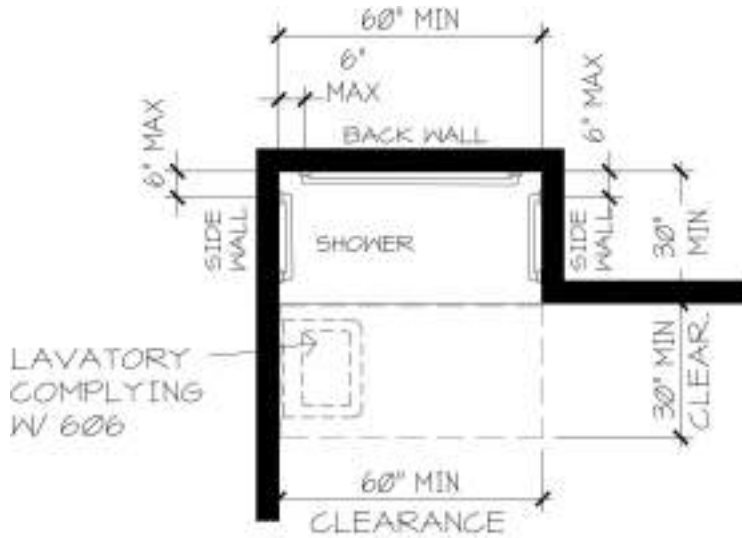

ASSISTED BATHING ROLL-IN SHOWER - MINIMUM SIZE



ASSISTED BATHING ROLL-IN SHOWER - USING EXCEPTIONS EXAMPLE 1



ASSISTED BATHING ROLL-IN SHOWER - USING EXCEPTIONS EXAMPLE 2

Bibliography:

Lee, S.J., Sanford, J., Calkins, M. Meglen, S., Endicott, S. & Phillips, A. (2017) Beyond ADA accessibility: Meeting seniors' needs for toilet transfers. HERD. DOI: 10.1177/1937586717730338

Cost Impact

The code change proposal will increase the cost of construction .

Costs will be minimal. It is will likely be equal when replacing the folding seat with a grab bar. Both require blocking in the wall. If a designer chooses the minimum size shower, the size requirements will be the same as currently required. This allows for additional design options.

Internal ID: 701

E130-18

IBC: 1109.6 (New), Chapter 35

Proponent: Dawn Anderson, representing self (gonedawning@yahoo.com); Dan Buuck, representing National Association of Home Builders (dbuuck@nahb.org); David Collins, representing the American Institute of Architects (dcollins@preview-group.com); Marsha Mazz, representing U.S. Access Board (mazz@Access-Board.gov); Dominic Marinelli, representing United Spinal Association (DMarinelli@accessibility-services.com)

2018 International Building Code

Update standard(s) as follows:

ICC

International Code Council, Inc.
500 New Jersey Ave NW 6th Floor
Washington DC 20001
US

ICC A117.1-092017:

Accessible and Usable Buildings and Facilities

Add new text as follows:

1109.6 Bottle filling stations. Where bottle filling stations are provided, they shall be accessible.

Exception: Bottle filling stations over drinking fountains for standing persons are not required to be accessible provided bottle filling stations are also located over the drinking fountains for persons using wheelchairs.

Reason:

In the interest of reducing the usage of disposable bottles for water, many schools are providing bottle filling stations. Due to security limitations, bottle filling stations are also being provided in airports. All operable parts intended for use by occupants must be accessible. The requirements for standing drinking fountains potentially will not allow for complaint reach over an obstruction. When the bottle filling stations are provided over the wheelchair drinking fountains, having them also over the standing drinking fountains would be providing redundant facilities.

□



Cost Impact

The code change proposal will not increase or decrease the cost of construction .

This is a requirement for filling station location and height. It does not change any technical criteria for such stations.

Analysis: The 2009 edition of the ICC A117.1 standard is referenced in Chapter 35.

Internal ID: 543

E131-18

IBC: 1109.13

Proponent: Gene Boecker, representing Code Consultants, Inc. (geneb@codeconsultants.com)

2018 International Building Code

Revise as follows:

~~1109.12~~**1109.13 Dressing, fitting and locker rooms.** Where dressing rooms, fitting rooms or locker rooms are provided, at least 5 percent, but not less than one, of each type of use in each cluster provided shall be *accessible*.

Reason:

The requirement needs to be its own section. As it is presently located, the provision is subordinate to the charging section which only addresses "service facilities." Employee locker rooms, locker rooms in residential buildings and locker rooms at the public pool would not be addressed since they are not service facilities. This is not consistent with the federal ADA or FHA. By moving the requirement to it's own section, it will be able to apply to all types of locker rooms and dressing rooms, consistent with the intent for equal access.

Cost Impact

The code change proposal will not increase or decrease the cost of construction .

The proposal is simply clarifying the intent.

Internal ID: 930

E132-18

IBC: 1109.12.3, Chapter 35

Proponent: Dawn Anderson, representing self (gonedawning@yahoo.com); Dan Buuck, representing National Association of Home Builders (dbuuck@nahb.org); David Collins, representing the American Institute of Architects (dcollins@preview-group.com); Marsha Mazz, representing U.S. Access Board (mazz@Access-Board.gov); Dominic Marinelli, representing United Spinal Association (DMarinelli@accessibility-services.com)

2018 International Building Code

Revise as follows:

1109.12.3 ~~Point of sale~~ Sales and service counters, counters and windows. Where counters or windows are provided for ~~sales~~ sale or distribution of goods or services, at least one of each type of counter and window provided shall be *accessible*. Where such counters or windows are dispersed throughout the building or facility, *accessible* counters or windows shall also be dispersed.

Update standard(s) as follows:

ICC

International Code Council, Inc.
500 New Jersey Ave NW 6th Floor
Washington DC 20001

US

ICC A117.1-~~09~~2017:

Accessible and Usable Buildings and Facilities

Reason:

The 2017 A117.1 has significantly improved technical criteria for service counters and windows, including provisions for a line of sight between the customers and employees and provisions for security glazing. The scoping requirements need to be coordinated to include service windows without counters. The title is simplified. A117.1 exempts drive-up only counters and windows, so a similar exception is not needed here. The proposal adds “windows” as a service element to clarify that these types of interactive elements must be accessible just like a counter. Service windows have been interpreted to be a type of service counter.

Cost Impact

The code change proposal will not increase or decrease the cost of construction .

The change has the effect to clarify the intent and remove ambiguity.

Analysis: The 2009 edition of the ICC A117.1 standard is referenced in Chapter 35.

Internal ID: 544

E133-18

IBC: 1109.13, Chapter 35

Proponent: Dawn Anderson, representing self (gonedawning@yahoo.com); Dan Buuck, representing National Association of Home Builders (dbuuck@nahb.org); David Collins, representing the American Institute of Architects (dcollins@preview-group.com); Marsha Mazz, representing U.S. Access Board (mazz@Access-Board.gov); Dominic Marinelli, representing United Spinal Association (DMarinelli@accessibility-services.com)

2018 International Building Code

Revise as follows:

1109.13 Controls, operating mechanisms and hardware. Controls, operating mechanisms and hardware intended for operation by the occupant, including switches that control lighting and ventilation and electrical convenience outlets, in *accessible* spaces, along *accessible routes* or as parts of *accessible* elements shall be *accessible*.

Exceptions:

1. Operable parts that are intended for use only by service or maintenance personnel shall not be required to be *accessible*.
- ~~2. Electrical or communication receptacles serving a dedicated use shall not be required to be *accessible*.~~
- ~~3. Where two or more outlets are provided in a kitchen above a length of counter top that is uninterrupted by a sink or appliance, one outlet shall not be required to be *accessible*.~~
- ~~4. Floor electrical receptacles shall not be required to be *accessible*.~~
- ~~5. HVAC diffusers shall not be required to be *accessible*.~~
- ~~6. Except for light switches, where redundant controls are provided for a single element, one control in each space shall not be required to be *accessible*.~~
- ~~27. Access doors or gates in barrier walls and fences protecting pools, spas and hot tubs shall be permitted to comply with Section 1010.1.9.2.~~
3. Operable parts exempted in accordance with ICC A117.1 are not required to be *accessible*.

Update standard(s) as follows:

ICC

International Code Council, Inc.
500 New Jersey Ave NW 6th Floor
Washington DC 20001
US

ICC A117.1-092017:

Accessible and Usable Buildings and Facilities

Reason:

The purpose of this proposal is coordination with the 2017 ICC A117.1 exceptions for operable parts in Section 309.1. All current exceptions proposed to be deleted are listed in ICC A117.1 Section 309.1, plus an additional 5 new exceptions. Since the code requirements and override allowances in a standard, the new exception will allow for exceptions listed in ICC A117.1. This will maintain coordination of this item over time.

Below is the language from the 2017 ICC A117.1 for reference. The applicable exceptions are underlined.

309.1 General. Operable parts shall comply with Section 309.

Exceptions:

1. Receptacle outlets serving a dedicated use.
2. Where two or more receptacle outlets are provided in a kitchen above a length of countertop that is uninterrupted by a sink or appliance, one receptacle outlet shall not be required to comply with this section.
3. In a kitchen, where a clear floor space for a parallel approach cannot be located at a countertop in a corner between appliances, receptacle outlets over the countertop shall not be required to comply with this section provided that the countertop area does not exceed 9 square feet (0.835 m²) maximum.

4. Floor receptacle outlets.
5. HVAC diffusers.
6. Controls mounted on ceiling fans.
7. Where redundant controls other than light switches are provided for a single element, one control in each space shall not be required to comply with this section.
8. Reset buttons and shut-offs serving appliances, piping and plumbing fixtures.
9. Electrical panelboards shall not be required to comply with Section 309.4.
10. Emergency aid devices, such as fire department hose connections, valve controls, gauges, police call boxes and annunciator panels shall not be required to comply with this section provided that they are used only for emergencies by emergency personnel acting in their official capacity.

Cost Impact

The code change proposal will not increase or decrease the cost of construction .

The proposal points to exceptions to the operable parts requirements in A117.1 which might otherwise be missed. The change is only correlative and contains, in itself, no substantive changes.

Analysis: The 2009 edition of the ICC A117.1 standard is referenced in Chapter 35.

Internal ID: 549

E134-18

IBC: 1110.4.14

Proponent: Gene Boecker, representing Code Consultants, Inc. (geneb@codeconsultants.com)

2018 International Building Code

Revise as follows:

1110.4.14 Swimming pools, wading pools, cold baths, hot tubs and spas. Swimming pools, wading pools, cold baths, hot tubs and spas shall be *accessible* and be on an *accessible route*.

Exceptions:

1. Catch pools or a designated section of a pool used as a terminus for a water slide flume shall not be required to provide an *accessible* means of entry, provided that a portion of the catch pool edge is on an *accessible route*.
2. Where spas, cold baths or hot tubs are provided in a cluster, at least 5 percent, but not less than one of each type spa, cold baths or hot tub in each cluster, shall be *accessible* and be on an *accessible route*.
3. Swimming pools, wading pools, spas, cold baths and hot tubs that are required to be *accessible* by Sections 1110.2.2 and 1110.2.3 are not required to provide *accessible* means of entry into the water.

Reason:

The proposal includes two changes: clarification that the intent is to have access to at least one of each type of aquatic element and the addition of cold baths.

As written, it could be interpreted that if a cluster included a hot tub and a spa as a cluster, access would only be required to one of those although they are different types of elements - with bubbles and without. The change makes the language consistent with the intent of the federal ADA.

The second is a change to include cold baths as another type. This is a different thermal experience and should be included, consistent with the intent of the ADA for equal access.

Cost Impact

The code change proposal will increase the cost of construction .

With the addition of "cold baths" to the list, access to some elements which did not necessarily require access before would increase construction cost. The otehr change woudl not affect cost since it is in keeping with the original intent.

Internal ID: 929

E135-18

IBC: 1110.4.15, Chapter 35

Proponent: Dawn Anderson, representing self (gonedawning@yahoo.com); Dan Buuck, representing National Association of Home Builders (dbuuck@nahb.org); David Collins, representing the American Institute of Architects (dcollins@preview-group.com); Dominic Marinelli, representing United Spinal Association (DMarinelli@accessibility-services.com)

2018 International Building Code

Revise as follows:

1110.4.15 Shooting facilities with firing positions. Where shooting facilities with firing positions are designed and constructed at a site, at least 5 percent, but not less than one, of each type of firing position shall be *accessible* and be on an *accessible route*.

Exception: Shooting facilities with firing positions on free-standing platforms that are elevated above grade 12 feet (3660 mm) minimum provided that the aggregate area of elevated firing positions is 500 square feet (46 m²) maximum are not required to be accessible

Update standard(s) as follows:

ICC

International Code Council, Inc.
500 New Jersey Ave NW 6th Floor
Washington DC 20001

US

ICC A117.1-~~09~~2017:

Accessible and Usable Buildings and Facilities

Reason:

The 2017 ICC A117.1 exempts elevated shooting stations and is consistent with the 2010 ADA Standards. These stations are elevated so that hunters can practice shooting from an elevated location, such as a tree stand. The size limitations are similar to those specified for press boxes. Where facilities are required to be accessible is a scoping issue, so this exception should be based in the building code. The other exceptions in ICC A117.1 Section 1001.2.1 are all found in the IBC in the applicable sections in Section 1110.

A117.1 2017

1001.2.1 General Exceptions. The following shall not be required comply with this standard or to be on an accessible route:

1. Raised structures used solely for refereeing, judging, or scoring a sport. (IBC 1110.4.6)
2. Water Slides. (IBC 1110.4.13.2)
3. Animal containment areas that are not for public use. (IBC 1110.4.8)
4. Raised boxing or wrestling rings.(IBC 1110.4.5)
5. Raised diving boards and diving platforms. (IBC 1110.4.13.2)
6. Bowling lanes that are not required to provide wheelchair spaces. (IBC 1110.4.3)
7. Mobile or portable amusement rides. (IBC 1110.4.8)
8. Amusement rides that are controlled or operated by the rider. (IBC 1110.4.8.3 Exp. 1)
9. Amusement rides designed primarily for children, where children are assisted on and off the ride by an adult. (IBC 1110.4.8.3 Exp. 2)
10. Amusement rides that do not provide amusement ride seats. (IBC 1110.4.8.3 Exp. 3)
11. Shooting facilities with firing positions on free-standing platforms that are elevated above grade 12 feet (3660 mm) minimum provided that the aggregate area of elevated firing positions is 500 square feet (46 m²) maximum.

Cost Impact

The code change proposal will decrease the cost of construction .

Exceptions always decrease costs - that's why we love them.

Analysis: The 2009 edition of the ICC A117.1 standard is referenced in Chapter 35.

Internal ID: 545

E136-18

IBC: 1111.1, 1111.2 (New)

Proponent: Dawn Anderson, representing self (gonedawning@yahoo.com); Dan Buuck, representing National Association of Home Builders (dbuuck@nahb.org); David Collins, representing the American Institute of Architects (dcollins@preview-group.com); Marsha Mazz, representing U.S. Access Board (mazz@Access-Board.gov); Dominic Marinelli, representing United Spinal Association (DMarinelli@accessibility-services.com)

2018 International Building Code

Revise as follows:

1111.1 Signs. Required *accessible* elements shall be identified by the International Symbol of Accessibility at the following locations.

1. *Accessible* parking spaces required by Section 1106.1.
Exception: Where the total number of parking spaces provided is four or less, identification of *accessible* parking spaces is not required.
2. *Accessible* parking spaces required by Section 1106.2.
Exception: In Group I-1, R-2, R-3 and R-4 facilities, where parking spaces are assigned to specific *dwelling units* or *sleeping units*, identification of *accessible* parking spaces is not required.
3. *Accessible* passenger loading zones.
4. *Accessible* toilet or bathing rooms where ~~multiple single user~~ not all toilet or bathing rooms are clustered at a single location accessible.
5. *Accessible* entrances where not all entrances are *accessible*.
6. *Accessible* check-out aisles where not all aisles are *accessible*. The sign, where provided, shall be above the check-out aisle in the same location as the checkout aisle number or type of check-out identification.
- ~~7. Family or assisted use toilet and bathing rooms.~~
- ~~8-7.~~ *Accessible* dressing, fitting and locker rooms where not all such rooms are *accessible*.
- ~~9-8.~~ *Accessible* areas of refuge in accordance with Section 1009.9.
- ~~10-9.~~ Exterior areas for assisted rescue in accordance with Section 1009.9.
- ~~11-10.~~ In recreational facilities, lockers that are required to be *accessible* in accordance with Section 1109.9.

Add new text as follows:

1111.2 Signs identifying toilet or bathing rooms. Signs required in Section 403.4 of the International Plumbing Code identifying toilet rooms and bathing rooms shall be visual characters, raised characters and braille complying with ICC A117.1. Where pictograms are provided as designations for toilet rooms and bathing rooms, the pictograms shall have visual characters, raised characters and braille complying with ICC A117.1.

Reason:

The intent of this proposal is to provide a missing piece of signage information in Section 1111 for toilet and bathing rooms. IPC Section 403.4 references back to IBC Section 1111 for requirements for accessible signage.

While Appendix E, Section E107.2 in the IBC addresses room signage that is not required in the codes, signs are required at toilet and bathing rooms by IPC Section 403.1.2, 403.2.1 and 403.4. Similar to exit signs (required in IBC Sections 1013.1 and 1013.4) and stairway signage (required in IBC Sections 1023.9), where signs are required, the same information must be available to persons with vision impairments. Some information on toilet and bathing room signage is stated in IBC Section 1111.1 (International Symbol for Accessibility) and 1111.2 (directional signage), but not any information on room designation.

It is suggested to reorder the signage requirements in 1111.1 to group like subjects together.

Section 1111.1 current Exception 4 is revised to clarify that the International Symbol for Accessibility is required at

accessible toilet and bathrooms rooms where not all toilet and bathing rooms in the building are accessible. This is consistent with the general intent for signage - the accessibility symbol is not required if all like elements are accessible. The current language in Exception 4 would only be applicable to clustered single occupant bathrooms that take advantage of the 50% allowance in Section 1109.2 Exception 3. Buildings being altered or with additions may not have all bathrooms accessible. A more generic reference would allow the same consideration for family or assisted use toilet facilities or bathing rooms, so current Exception 7 is not needed.

A new section 1111.2 would add specific criteria for toilet and bathing room signage other than the International Symbol for Accessibility (Section 1111.1). The language is consistent with the terminology for permanent rooms and spaces specified in E107.2 for permanent room designation.

Cost Impact

The code change proposal will not increase or decrease the cost of construction .

The sign is already required by the 2010 ADA Standard to be accessible. This clarification could reduce where the International Symbol of Accessibility was required on a sign.

Internal ID: 555

E137-18

IBC: E104.2.2

Proponent: Jeffrey Shapiro, representing Self (jeff.shapiro@intlcodeconsultants.com)

2018 International Building Code

Revise as follows:

E104.2.2 Group I-3. In Group I-3 occupancies at least 2 percent, but no fewer than one of the total number of general holding cells and general housing cells equipped with ~~audible emergency alarm systems~~ notification devices and permanently installed telephones within the cell, ~~shall comply~~ both complying with Section E104.2.4.

Reason:

The type of alarm referenced in this section is not considered an emergency alarm system, as defined in Section 202 and regulated by Section 908. Instead, the intent of the section appears to be triggering the requirements in Section E104.2.4. If the intent of the current text is to require that visual notification devices AND a permanently installed telephone be provided in 2% of cells, then the section requires addition revision for clarity. This proposal suggests such a revision to open the question to discussion, and provides a clarifying text to be used if there is agreement on how the section should be applied.

Elimination of the "emergency alarm systems" text is necessary to correlate with revisions to emergency alarm provisions done last cycle by F75-16 because the system required by this section is not in the scope of the code's emergency alarm system requirements.

Cost Impact

The code change proposal will decrease the cost of construction .

Removes the implication that an alarm system is required vs. simply emergency alarm devices that are correlated to this section in Section E104.2.4.

Internal ID: 2183

2018 GROUP A – PROPOSED CHANGES TO THE INTERNATIONAL BUILDING CODE – FIRE SAFETY

FIRE SAFETY CODE COMMITTEE

Kenneth E. Bush, Chair

Rep: National Association of State Fire Marshals
Chief Fire Protection Engineer
Maryland State Fire Marshal's Office
Easton, MD

Joseph McElvaney, Jr., PE, Vice Chair

Lead Fire Protection Engineer
City of Phoenix Fire Department
Phoenix, AZ

Nelson Bryner

Chief, Fire Research Division
National Institute of Standards and Technology
Gaithersburg, MD

Matthew Dobson

Rep: National Association of Home Builders
Vice President, Regulatory and Advocacy
Vinyl Siding Institute
Burlington, NC

Kevin Duerr-Clark, PE

Assistant Director for Technical Support,
Professional Engineer II
NY Department of State, Division of Building
Standards and Codes
Albany, NY

Kara Gerczynski

Rep: Fire Marshal's Association of Colorado
Fire Marshal
Elizabeth Fire Protection District
Kiowa, CO

Robert M. Longo, AIA

Rep: AIA New Jersey
Partner
Cornerstone Architectural Group LLC
South Plainfield, NJ

John Mengedoht, AIA

Senior Associate
NBBJ
Seattle, WA

Bob D. Morgan, PE, CPCU

Senior Fire Protection Engineer
Fort Worth Fire Department
Fort Worth, TX

Dennis Richardson, PE, CBO

Western Regional Manager
American Wood Council
Santa Rosa, CA

Richard A. Soltis, Jr.

Fire SubCode Official
Lawrence Township
Lawrence, NJ

John Swanson

Deputy State Fire Marshal-Inspector/Plans
Examiner
Minnesota State Fire Marshal Division
Lakeville, MN

Michael Tomaselli, PE, M. Eng

Fire Protection Engineer
Anne Arundel County
Annapolis, MD

Richard N. Walke

Senior Regulatory Engineer
Underwriters Laboratories
Northbrook, IL

Mang sum Mercy Wong, RA

Code Development Architect-Technical Affairs
and Code Development
New York Department of Buildings
New York, NY

Staff Secretariat

Kermit Robinson

Senior Technical Staff
International Code Council
Western Regional Office
Brea, CA

Michelle Britt, LEED AP

Director, Energy Programs
Technical Services
International Code Council
Central Regional Office
Country Club Hills, IL

TENTATIVE ORDER OF DISCUSSION 2018 PROPOSED CHANGES TO THE INTERNATIONAL PROPERTY MAINTENANCE CODE

The following is the tentative order in which the proposed changes to the code will be discussed at the public hearings. Proposed changes which impact the same subject have been grouped to permit consideration in consecutive changes.

Proposed change numbers that are indented are those which are being heard out of numerical order. Indentation does not necessarily indicate that one change is related to another. Proposed changes may be grouped for purposes of discussion at the hearing at the discretion of the chair. Note that some FS code change proposals may not be included on this list, as they are being heard by another committee.

F4-18, Part II	FS38-18	FS75-18	FS112-18
G7-18	FS39-18	FS76-18	FS113-18
G12-18	FS40-18	FS77-18	FS114-18
FS1-18	FS41-18	FS78-18	FS115-18
FS2-18	FS42-18	FS79-18	FS116-18
FS3-18	FS43-18	FS80-18	G6-18
FS4-18	FS44-18	F92-18 Part II	FS117-18
FS7-18	FS45-18	FS82-18	FS118-18
FS8-18	FS46-18	FS83-18	FS119-18
FS9-18	FS47-18	FS84-18	FS120-18
FS10-18	FS48-18	FS85-18	FS121-18
FS11-18	FS49-18	FS86-18	FS122-18
FS12-18	FS50-18	FS87-18	FS123-18
FS13-18	FS51-18	FS88-18	FS124-18
FS14-18	FS52-18	FS89-18	FS125-18
FS15-18	FS53-18	FS90-18	FS126-18
FS16-18	FS54-18	E97-18	FS127-18
FS17-18	FS55-18	FS91-18	FS128-18
FS18-18	FS56-18	FS92-18	FS129-18
FS19-18	FS57-18	FS93-18	FS130-18
FS20-18	FS58-18	FS94-18	FS131-18
FS21-18	FS59-18	FS95-18	FS132-18
FS22-18	FS60-18	FS96-18	FS133-18
FS23-18	FS61-18	FS97-18	FS134-18
FS24-18	G34-18	FS98-18	FS135-18
FS25-18	FS62-18	FS99-18	FS136-18
FS26-18	FS63-18	FS100-18	FS137-18
FS27-18	FS64-18	FS101-18	FS138-18
FS28-18	FS65-18	FS102-18	FS139-18
FS29-18	FS66-18	FS103-18	FS140-18
FS30-18	FS67-18	FS104-18	FS141-18
FS31-18	FS68-18	FS105-18	FS142-18
FS32-18	FS69-18	FS106-18	FS143-18
FS33-18	FS70-18	FS107-18	FS144-18
FS34-18	FS71-18	FS108-18	FS145-18
FS35-18	M72-18	FS109-18	FS146-18
FS36-18	FS72-18	FS110-18	FS147-18
FS37-18	FS74-18	FS111-18	FS148-18

FS149-18
FS150-18
FS151-181
 S2-18
 S3-18
 S4-18
FS152-18
 S5-18
 S6-18
 S7-18
 S8-18
 S9-18
FS153-18
 G3-18
 S6-18
FS154-18
 S14-18
 S15-18
 S16-18
 S17-18
 S18-18
 S19-18
 S20-18
 S21-18
 G10-18
 G11-18
FS155-18
FS156-18
FS157-18
FS158-18
FS159-18
FS160-18
FS161-18

FS1-18

IBC: 703.2, 703.4

Proponent: Jeffrey Shapiro, representing Tyco Fire Products (jeff.shapiro@intlcodeconsultants.com)

2018 International Building Code

Revise as follows:

703.2 Fire-resistance ratings. The *fire-resistance rating* of building elements, components or assemblies shall be determined in accordance with the test procedures set forth in ASTM E119 or UL 263, without the use of automatic sprinklers or any other fire suppression system being incorporated as part of the test, or in accordance with Section 703.3. The *fire-resistance rating* of penetrations and *fire-resistant joint systems* shall be determined in accordance Sections 714 and 715, respectively.

703.3 Methods for determining fire resistance. The application of any of the methods listed in this section shall be based on the fire exposure and acceptance criteria specified in ASTM E119 or UL 263. The required *fire resistance* of a building element, component or assembly shall be permitted to be established by any of the following methods or procedures:

1. *Fire-resistance* designs documented in approved sources.
2. Prescriptive designs of fire-resistance-rated building elements, components or assemblies as prescribed in Section 721.
3. Calculations in accordance with Section 722.
4. Engineering analysis based on a comparison of building element, component or assemblies designs having *fire-resistance ratings* as determined by the test procedures set forth in ASTM E119 or UL 263.
5. Alternative protection methods as allowed by Section 104.11.
6. *Fire-resistance* designs certified by an approved agency.

Delete without substitution:

~~**703.4 Automatic sprinklers.** Under the prescriptive fire resistance requirements of this code, the *fire resistance rating* of a building element, component or assembly shall be established without the use of *automatic sprinklers* or any other fire suppression system being incorporated as part of the assembly tested in accordance with the fire exposure, procedures and acceptance criteria specified in ASTM E119 or UL 263. However, this section shall not prohibit or limit the duties and powers of the *building official* allowed by Sections 104.10 and 104.11.~~

Reason:

This proposal captures discussion points from previous cycles and provides a simpler approach to dealing with limiting the E119 test protocol to not include fire suppression systems. Although E119 doesn't allow this, it is understood that some interest groups have wanted the point emphasized in the IBC. In this proposal, the technical restrictions in 703.4 have been relocated to Section 703.2, since this is where compliance with E119 is established in the IBC. It's a more suitable place for the fire-suppression system limitation to reside. Alternatives to E119, including the reference to alternative methods per Section 104.11, will once again be consolidated in 703.3 without having to rely on a separate section (703.4) that is redundant with respect to performance-based alternatives. If you compare the text of this proposal with the current text in 703.4, you will see that it is closely aligned so as to maintain the intent of current provisions while eliminating confusion and concern associated with Section 703.4. Note that existing subsections of Section 703.2 are to be retained without change and are shown for clarity to see how the provisions fit together.

Cost Impact

The code change proposal will not increase or decrease the cost of construction .

The proposal is a clarification of how the code applies.

Internal ID: 2374

FS2-18

IBC: 703.5, 703.5.1, 703.5.2

Proponent: Tim Earl, GBH International, representing self (tearl@gbhinternational.com)

2018 International Building Code

Revise as follows:

703.5 Noncombustibility tests. The tests indicated in ~~Sections~~ Section 703.5.1 and ~~703.5.2~~ shall serve as criteria for acceptance of building materials as set forth in Sections 602.2, 602.3 and 602.4 in Types I, II, III and IV construction. The term “noncombustible” does not apply to the flame spread characteristics of *interior finish* or *trim* materials. A material shall not be classified as a noncombustible building construction material if it is subject to an increase in combustibility or flame spread beyond the limitations herein established through the effects of age, moisture or other atmospheric conditions.

703.5.1 Elementary-Non-combustible materials. Materials required to be noncombustible shall be tested in accordance with ASTM E136.

Exception: Materials having a structural base of noncombustible material as determined in accordance with this section with a surfacing of not more than 0.125 inch (3.18 mm) thick that has a flame spread index not greater than 50 when tested in accordance with ASTM E84 or UL 723 shall be acceptable as non-combustible.

Delete without substitution:

~~**703.5.2 Composite materials.** Materials having a structural base of noncombustible material as determined in accordance with Section 703.5.1 with a surfacing not more than 0.125 inch (3.18 mm) thick that has a *flame spread index* not greater than 50 when tested in accordance with ASTM E84 or UL 723 shall be acceptable as noncombustible materials.~~

Reason:

This current language is technically incorrect. The intent of the section title of Section 703.5.1 is to describe materials which are not layered and have a uniform structure throughout. This is complicated by the fact that the title is not reflected in the text of the section, so there is a disconnect. With Section 703.5.2, the problem is similar. While the title 'composite materials' isn't specifically used in the text, the text does describe a 'composite' of materials. In our efforts to correct the titles and have the titles clearly reflected in the text, we realized that a big part of the problem was the organization of these 3 sections. We believe our proposed solution results in clearer code and simpler code. This proposal does not result in any technical change to the code requirements.

Cost Impact

The code change proposal will not increase or decrease the cost of construction .

This proposal cleans up incorrect language and will have no impact on construction costs. It is essentially editorial.

Internal ID: 505

FS3-18

IBC: 703.5.1, Chapter 35

Proponent: Tony Crimi, A.C. Consulting Solutions Inc., representing North American Insulation Manufacturers Association (NAIMA)

2018 International Building Code

Revise as follows:

703.5.1 Elementary materials. Materials required to be noncombustible shall be tested in accordance with ASTM E136, or ASTM E2652, using the acceptance criteria prescribed by ASTM E136.

Add new standard(s) follows:

ASTM

ASTM International
100 Barr Harbor Drive, P.O. Box
C700
West Conshohocken PA 19428-
2959

E2652-16:

Standard Test Method for Behavior of Materials in a Tube Furnace with a Cone-shaped Airflow Stabilizer at 750oC

Reason:

Several of the I-Codes have varying definitions of the term “non-combustible material”, each based upon the way in which the concept of “non-combustible” is used within that Code. Throughout the ICC code system, the concept of “noncombustible material” is based on the idea that the material should not ignite or burn when subjected to fire or heat. Our intent is to require the same pass/fail criteria as currently exists in ASTM E136, using all fo the thermocouples required by ASTM E136, but using the ASTM E2652 apparatus. When ASTM E2652 is used, the pass/fail criteria and methodology are those required by ASTM E136.

The concept of “noncombustible materials” and “noncombustibility” in terms of types of construction is widely used throughout the International Codes. The IBC, IFC, IEBC and IFGC do not contain a separate definition of “noncombustible”, even though they use the terminology “non-combustible materials”.

In common usage, the term “noncombustible” is used to denote materials which do not ignite or are not capable of sustaining combustion. The common Dictionary definitions for “noncombustible” are typically as follows:

Noncombustible, adj - incapable of being burned

(Merriam -Webster’s International Dictionary of the English Language, Unabridged, 2013)

In the traditional use of the terminology and concept of “non-combustible” in the Codes has been based on acceptable performance when tested in accordance with ASTM E136, Test Method for Behavior of Materials in a Vertical Tube Furnace at 750 Degrees C. Materials passing the test are permitted limited flaming and other indications of combustion. However, these have traditionally been acceptable. Understandably, ASTM E136 does not replicate the full spectrum of actual building fire exposure conditions. However, this test method does provide an assessment indicating those materials which do not act to aid combustion or add appreciable heat to an ambient fire.

ASTM has published another standard ASTM E2652-16, entitled Standard Test Method for Behavior of Materials in a Tube Furnace with a Cone-shaped Airflow Stabilizer, at 750°C. This test method is similar to ASTM E136, but based on the international standard for Noncombustibility. The key difference between the two standards is in the equipment. The apparatuses in this test method and in Test Method E 136 is that the furnace tube in this test method has a conical air-flow stabilizer section attached at its bottom. Both test methods use cylindrical furnace tubes. Like ASTM E136, the test Standard does not include mandatory pass/fail criterion. It allows those criteria to be determined by the Codes or other users. Appendix X3 also contains a comparison of results obtained from this apparatus versus ASTM E136. ASTM E136 has already been revised to include ASTM E2652 as an alternate methodology.

Bibliography:

ASTM E2652-16 - Standard Test Method for Behavior of Materials in a Tube Furnace with a Cone- shaped Airflow Stabilizer, at 750°C.

Cost Impact

The code change proposal will not increase or decrease the cost of construction .

This is an additional option only.

Analysis: A review of the standard proposed for inclusion in the code, ASTM E2562-16, with regard to the ICC criteria for referenced standards (Section 3.6 of CP#28) will be posted on the ICC website on or before April 2, 2018.

Internal ID: 1091

FS4-18

IBC: 703.5.2

Proponent: Andy Williams, representing Metal Construction Association (afwilliams@Connect2amc.com)

2018 International Building Code

Revise as follows:

703.5.2 Composite materials. Materials having a structural base of noncombustible material as determined in accordance with Section 703.5.1 with a surfacing not more than 0.125 inch (3.18 mm) thick that has a *flame spread index* not greater than 50 for each component of the composite or laminate material when tested in accordance with ASTM E84 or UL 723 shall be acceptable as noncombustible materials.

Reason:

Section 703.5.2 was added into the code long ago to allow gypsum wallboard to be recognized as a noncombustible material. While no adhesive material is typically used in gypsum, there are a number of exterior wall cladding materials that are currently using this section to allow recognition as a noncombustible element. These products typically consist of a noncombustible core (aluminum), in either a honeycomb or corrugated format with a relatively thin layer of aluminum attached to both faces. The adhesives used to make this attachment are combustible however Section 703.5.2 is being used as a reason to not be concerned with the introduction of this combustible element.

With the recent high rise building fires worldwide recently, the concern is rapid flame spread on the exterior of the building that could take place using the adhesive as a transfer method.

Making this proposed change would remove laminates and composites using combustible adhesives from the noncombustible product category and make these products be compliant with NFPA 285 Standard Fire Test Method for Evaluation of **Fire Propagation** Characteristics of Exterior Non-Load-Bearing Wall Assemblies Containing **Combustible Components** when required in the Exterior Wall Section 1402.5.

While the combustible WRB alone may be acceptable and not trigger the need for NFPA 285 Compliance (1402.5 Exception 1), The addition of two layers of combustible adhesive (front and back) of the laminate or composite material would definitely add combustible material and most likely make the wall assembly non-compliant with the exceptions to Section 1402.5.



Corrugated Core (End View)



Upper Section - Cut away view of honeycomb core, combustible adhesive, with exterior aluminum skin

Lower Section - Same panel with exterior aluminum skin removed.

Cost Impact

The code change proposal will not increase or decrease the cost of construction .

Cost of NFPA 285 testing would be added to the overall cost of this product. Similar cost addition as other combustible wall assemblies.

Internal ID: 1263

FS5-18

IBC: 703.8 (New)

Proponent: Stephen DiGiovanni, representing ICC Ad Hoc Committee on Tall Wood Buildings (TWB) (TWB@iccsafe.org)

THIS CODE CHANGE WILL BE HEARD BY THE IBC GENERAL COMMITTEE. SEE THE TENTATIVE HEARING ORDER FOR THIS COMMITTEE.

2018 International Building Code

Add new text as follows:

703.8 Determination of noncombustible protection time contribution. The time, in minutes, contributed to the fire resistance rating by the noncombustible protection of mass timber building elements, components, or assemblies, shall be established through a comparison of assemblies tested using procedures set forth in ASTM E 119 or UL 263. The test assemblies shall be identical in construction, loading, and materials, other than the noncombustible protection. The two test assemblies shall be tested to the same criteria of structural failure.

1. Test Assembly 1 shall be without protection.
2. Test Assembly 2 shall include the representative noncombustible protection. The protection shall be fully defined in terms of configuration details, attachment details, joint sealing details, accessories and all other relevant details.

The noncombustible protection time contribution shall be determined by subtracting the fire resistance time, in minutes, of Test Assembly 1 from the fire resistance time, in minutes, of Test Assembly 2.

Reason:

The Ad Hoc Committee on Tall Wood Buildings (TWB) was created by the ICC Board to explore the science of tall wood buildings and take action on developing code changes for tall wood buildings. The TWB has created several code change proposals with respect to the concept of tall buildings of mass timber and the background information is at the end of this Statement. Within the statement are important links to information, including documents and videos, used in the deliberations which resulted in these proposals.

The TWB determined that the fire resistance rating of mass timber structural elements, embodied in a series of proposals including this one, shall consist of the inherent fire resistance rating of the mass timber and the additional fire resistance rating of the Noncombustible Protection described in new definitions proposals. The TWB determined that at least 2/3 of the required fire resistance rating should come from the Noncombustible Protection. The TWB decided to provide both a performance path, as embodied in this proposal, and a prescriptive path, embodied in another proposal for Section 722.7.

This proposal constitutes the performance path for determining the contribution of noncombustible protection for mass timber elements. The proposal outlines a protocol to accomplish this. This proposal should be considered as a companion proposal to the proposals creating new types of mass timber construction in Section 602.4 and the code proposal in Section 722.7. The proposed new Section 602.4 requires the use of noncombustible protection on most mass timber elements in most of the proposed new types of construction.

This proposal, new section 703.8, is created to provide the method by which any material not contained in the prescriptive Table in Section 722.7 may be tested to show the time, in minutes, which it contributes as noncombustible protection. This procedure is representative of the procedure used in the past to determine the protection times for various membranes in Section 722.6 Component Additive Method for wood construction. It is neither new nor ambiguous in its use. Recent testing by AWC confirms the values derived from historic testing. A report is available at the following link: <http://bit.ly/WFC-firetestofGWBonCLT> . This link was confirmed active on 12/27/17.

This procedure should not be confused with “membrane protection” which is based on temperature rise on the unexposed side of a membrane attached to construction elements. Noncombustible construction is, instead, noncombustible material meeting the requirements of Section 703.5. Its contribution to the fire resistance rating of any building element is determined by this proposed new section. Simply put, it is determined by measuring the fire resistance time, in minutes and determined by structural failure, of a mass timber building element and then conducting a second test measuring the fire resistance time, in minutes and determined by structural failure, of the identical mass timber element with identical load, construction and condition, but with the proposed noncombustible protection applied to it. The difference in time between the two samples is the contribution, in minutes, of the noncombustible protection.

Background information: The ICC Board approved the establishment of an ad hoc committee for tall wood

buildings in December of 2015. The purpose of the ad hoc committee is to explore the science of tall wood buildings and to investigate the feasibility and take action on developing code changes for tall wood buildings. The committee is comprised of a balance of stakeholders with additional opportunities for interested parties to participate in the four Work Groups established by the ad hoc committee, namely: Code; Fire; Standards/Definitions; and Structural. For more information, be sure to visit the ICC website <https://www.iccsafe.org/codes-tech-support/cs/icc-ad-hoc-committee-on-tall-wood-buildings/> (link active and up to date as of 12/27/17). As seen in the “Meeting Minutes and Documents” and “Resource Documents” sections of the committee web page, the ad hoc committee reviewed a substantial amount of information in order to provide technical justification for code proposals.

The ad hoc committee developed proposals for the followings code sections. The committee believes this package of code changes will result in regulations that adequately address the fire and life safety issues of tall mass timber buildings.

IBC Code Section	Description
403.3.2	Water supply requirements for fire pumps in high rise buildings of Type IVA and IVB construction.
504.3	Allowable building height (feet) for buildings of Type IVA, IVB and IVC construction. No changes to Type IV HT construction.
504.4	Allowable building height (stories) for buildings of Type IVA, IVB and IVC construction. No changes to Type IV HT.
506.2	Allowable building area for buildings of Type IVA, IVB and IVC construction. No changes to Type IV HT.
508.4.4.1 509.4.1.1 (new)	Requirements for mass timber building elements serving as fire barriers or horizontal assemblies in buildings of Type IVB or IVC construction.
602.4	Type of Construction requirements for new proposed types of construction: Types IVA, IVB and IVC. No changes to Type IV HT construction. Includes definitions for new terms: Mass timber and Noncombustible protection (mass timber). THIS IS THE KEY CODE CHANGE PROPOSAL WHICH OUTLINES THE CONSTRUCTION REQUIREMENTS FOR THE PROPOSED NEW TYPE OF MASS TIMBER BUILDINGS. THE PROPOSAL ALSO ADDRESSES CONCEALED SPACES, ADHESIVE PERFORMANCE AND EXTERIOR WALL PROTECTION.
703.8 (new)	The performance method to determine the increase to the fire resistance rating provided by noncombustible protection applied to the mass timber building element.
703.9 (new)	Requirements for sealants and adhesives to be placed at abutting edges and intersections of mass timber building elements. The reason statement references a Group B proposal to Chapter 17 for special inspection requirements of sealants and adhesives.
718.2.1	Requirements on the use of mass timber building elements used for Fireblocking.
722.7 (new)	Requirements for the fire resistance rating of mass timber elements, including minimum required protection and gypsum board attachment requirements.
3102	Requirements for membrane structures using Type IV HT construction.
3314.7 (new)	New special precautions during construction of buildings of Types IVA, IVB and IVC construction: Standpipes; Water supply for fire department connections; Noncombustible protection required for mass timber elements as construction height increases.
Appendix	Requirements for walls, floors and roofs of Type IV HT construction in buildings located in Fire Districts.
IFC Code Section	Description
701.6	Requirements which stipulate the owner's responsibility to maintain inventory of all required fire resistance rated construction in buildings of Types IVA and IVB construction. This includes an annual inspection and proper repair where necessary.
Proposed changes to be submitted in 2019 Group B	
IBC Chapter 17	Required special inspections of mass timber construction <ul style="list-style-type: none"> • Structural • Sealants and adhesives (see IBC 703.8)
IBC Chapter 23	An update to referenced standard APA PRG 320 Standard for Performance –rated Cross-laminated Timber which is currently undergoing revision to ensure the adequacy of the adhesives under fire conditions.

In addition, fire tests designed to simulate the three new construction types (Types IVA, IVB and IVC) in the ad hoc committee proposals were conducted at the Alcohol Tobacco and Firearms test lab facility. The TWB was involved in the design of the tests, and many members witnessed the test in person or online. The results of the series of 5 fire tests provide additional support for these proposals, and validate the fire performance for each of the types of construction proposed by the committee. The fire tests consisted of one-bedroom apartments on two levels, with both apartments having a corridor leading to a stair. The purpose of the tests was to address the contribution of mass timber to a fire, the performance of connections, the performance of through-penetration fire stops, and to evaluate conditions for responding fire personnel.

To review a summary of the fire tests, please visit:

<http://bit.ly/ATF-firetestreport>

To watch summary videos of the fire tests, which are accelerated to run in 3 ½ minutes, please visit:

<http://bit.ly/ATF-firetestvideos>

Both of these links were confirmed active on 12/27/17.

Cost Impact

The code change proposal will not increase or decrease the cost of construction .

This section provides information that was not previously set forth in the code, and does not change the requirements of current code, thus there is no cost impact when compared with present requirements.

Internal ID: 942

FS6-18

IBC: 703.9 (New), Chapter 35

Proponent: Stephen DiGiovanni, representing ICC Ad Hoc Committee on Tall Wood Buildings (TWB) (TWB@iccsafe.org)

THIS CODE CHANGE WILL BE HEARD BY THE IBC GENERAL COMMITTEE. SEE THE TENTATIVE HEARING ORDER FOR THIS COMMITTEE.

2018 International Building Code

Add new text as follows:

703.9 Sealing of adjacent mass timber elements. In buildings of Type IVA, IVB, and IVC construction, sealant or adhesive shall be provided to resist the passage of air in the following locations:

1. At abutting edges and intersections of mass timber building elements required to be fire resistance-rated
2. At abutting intersections of mass timber building elements and building elements of other materials where both are required to be fire resistance-rated.

Sealants shall meet the requirements of ASTM C920. Adhesives shall meet the requirements of ASTM D3498.

Exception:Where sealant or adhesive is not a required component of a fire resistance-rated assembly.

Add new standard(s) follows:

ASTM

ASTM International
100 Barr Harbor Drive, P.O. Box
C700
West Conshohocken PA 19428-
2959
US

D3498-03(2011):

Standard Specification for Adhesives for Field-Gluing Plywood to Lumber Framing for Floor Systems

Reason:

The Ad Hoc Committee on Tall Wood Buildings (TWB) was created by the ICC Board to explore the science of tall wood buildings and take action on developing code changes for tall wood buildings. The TWB has created several code change proposals with respect to the concept of tall buildings of mass timber and the background information is at the end of this Statement. Within the statement are important links to information, including documents and videos, used in the deliberations which resulted in these proposals.

Mass timber has inherent properties of fire resistance, serving both to provide structural fire resistance and to safeguard against the spread of fire and smoke within a building or the spread of fire between structures.

When mass timber panels are connected together, fire tests have demonstrated that it is important for the abutting edges and intersections in the plane of and between the different planes of panels that form a separation to be sealed. The structures tested as part of the fire tests supporting this submittal were constructed with this sealing.

To review a summary of the fire tests, please visit:

<http://bit.ly/ATF-firetestreport>

To watch summary videos of the fire tests, which are accelerated to run in 3-1/2 minutes each, please visit:
<http://bit.ly/ATF-firetestvideos>.

Both of these links were confirmed active on 12/27/17.

The US CLT manual recommends a bead of construction adhesive. Construction adhesive or other sealant can be used to prevent air flow. When a wall or horizontal assembly serves as the separation between two atmospheres, a fire creates differential pressure where heated gasses raise the pressure and work to drive fire and hot gasses through the structure. Voids that are not properly sealed can serve as a conduit for air movement during a fire, so abutting edges and intersections are recommended to be sealed.

Periodic special inspections during construction are required to make sure it is clear that the appropriate sealant or adhesive is used and to establish inspections to verify for ongoing quality control. However, Chapter 17 is a Group B

topic. It will be taken up then. It is shown below for clarity and to emphasize the importance the TWB places on proper application of sealants and adhesives in mass timber construction.

1705.19 Sealing of Mass Timber. Periodic special inspections of sealants or adhesives shall be conducted where sealant or adhesive required by Section 703.9 is applied to mass timber building elements as designated in the approved construction documents.

Some panels are manufactured under proprietary processes to ensure there are no voids at these intersections. Where this proprietary process is incorporated and tested, there is no requirement for sealant or adhesive and an exception is provided for this instance. Where the sealant is not required and is not specifically excluded it is still considered to be a good practice covered by this section.

This code change proposal does not apply to “joints” as defined in Section 202 of the IBC as joints have their own requirements for the placement and inspection of fire resistant joint systems in IBC Section 715. Joints are defined as having an opening that is designed to accommodate building tolerances or to allow independent movement. Panels and members that are connected together as covered by this code change proposal do not meet the definition of a joint since they are rigidly connected and do not have an opening.

Background information: The ICC Board approved the establishment of an ad hoc committee for tall wood buildings in December of 2015. The purpose of the ad hoc committee is to explore the science of tall wood buildings and to investigate the feasibility and take action on developing code changes for tall wood buildings. The committee is comprised of a balance of stakeholders with additional opportunities for interested parties to participate in the four Work Groups established by the ad hoc committee, namely: Code; Fire; Standards/Definitions; and Structural. For more information, be sure to visit the ICC website <https://www.iccsafe.org/codes-tech-support/cs/icc-ad-hoc-committee-on-tall-wood-buildings/> (link active and up to date as of 12/27/17). As seen in the “Meeting Minutes and Documents” and “Resource Documents” sections of the committee web page, the ad hoc committee reviewed a substantial amount of information in order to provide technical justification for code proposals.

The ad hoc committee developed proposals for the followings code sections. The committee believes this package of code changes will result in regulations that adequately address the fire and life safety issues of tall mass timber buildings.

IBC Code Section	Description
403.3.2	Water supply requirements for fire pumps in high rise buildings of Type IVA and IVB construction.
504.3	Allowable building height (feet) for buildings of Type IVA, IVB and IVC construction. No changes to Type IV HT construction.
504.4	Allowable building height (stories) for buildings of Type IVA, IVB and IVC construction. No changes to Type IV HT.
506.2	Allowable building area for buildings of Type IVA, IVB and IVC construction. No changes to Type IV HT.
508.4.4.1 509.4.1.1 (new)	Requirements for mass timber building elements serving as fire barriers or horizontal assemblies in buildings of Type IVB or IVC construction.
602.4	Type of Construction requirements for new proposed types of construction: Types IVA, IVB and IVC. No changes to Type IV HT construction. Includes definitions for new terms: Mass timber and Noncombustible protection (mass timber). THIS IS THE KEY CODE CHANGE PROPOSAL WHICH OUTLINES THE CONSTRUCTION REQUIREMENTS FOR THE PROPOSED NEW TYPE OF MASS TIMBER BUILDINGS. THE PROPOSAL ALSO ADDRESSES CONCEALED SPACES, ADHESIVE PERFORMANCE AND EXTERIOR WALL PROTECTION.
703.8 (new)	The performance method to determine the increase to the fire resistance rating provided by noncombustible protection applied to the mass timber building element.
703.9 (new)	Requirements for sealants and adhesives to be placed at abutting edges and intersections of mass timber building elements. The reason statement references a Group B proposal to Chapter 17 for special inspection requirements of sealants and adhesives.
718.2.1	Requirements on the use of mass timber building elements used for Fireblocking.
722.7 (new)	Requirements for the fire resistance rating of mass timber elements, including minimum required protection and gypsum board attachment requirements.
3102	Requirements for membrane structures using Type IV HT construction.
3314.7 (new)	New special precautions during construction of buildings of Types IVA, IVB and IVC construction: Standpipes; Water supply for fire department connections; Noncombustible protection required for mass timber elements as construction height increases.
Appendix	Requirements for walls, floors and roofs of Type IV HT construction in buildings located in Fire Districts.
IFC Code Section	Description
701.6	Requirements which stipulate the owner's responsibility to maintain inventory of all required fire resistance rated construction in buildings of Types IVA and IVB construction. This includes an annual inspection and proper repair where necessary.
Proposed changes to be submitted in 2019 Group B	
IBC Chapter 17	Required special inspections of mass timber construction <ul style="list-style-type: none"> • Structural • Sealants and adhesives (see IBC 703.8)
IBC Chapter 23	An update to referenced standard APA PRG 320 Standard for Performance –rated Cross-laminated Timber which is currently undergoing revision to ensure the adequacy of the adhesives under fire conditions.

In addition, fire tests designed to simulate the three new construction types (Types IVA, IVB and IVC) in the ad hoc committee proposals were conducted at the Alcohol Tobacco and Firearms test lab facility. The TWB was involved in the design of the tests, and many members witnessed the test in person or online. The results of the series of 5 fire tests provide additional support for these proposals, and validate the fire performance for each of the types of construction proposed by the committee. The fire tests consisted of one-bedroom apartments on two levels, with both apartments having a corridor leading to a stair. The purpose of the tests was to address the contribution of mass timber to a fire, the performance of connections, the performance of through-penetration fire stops, and to evaluate conditions for responding fire personnel.

To review a summary of the fire tests, please visit:

<http://bit.ly/ATF-firetestreport>

To watch summary videos of the fire tests, which are accelerated to run in 3 ½ minutes, please visit:

<http://bit.ly/ATF-firetestvideos>

Both of these links were confirmed active on 12/27/17.

Cost Impact

The code change proposal will not increase or decrease the cost of construction .

This section provides information that was not previously set forth in the code, and does not change the requirements of current code, thus there is no cost impact when compared with present requirements.

Analysis: A review of the standard proposed for inclusion in the code, ASTM D3498-03(2011), with regard to the ICC criteria for referenced standards (Section 3.6 of CP#28) will be posted on the ICC website on or before April 2, 2018.

Internal ID: 943

FS7-18

IBC: 704.3 (New)

Proponent: Terry Maiers, BSB Design, Inc., representing BSB Design, Inc. (tmaiers@bsbdesign.com)

2018 International Building Code

Add new text as follows:

704.3 Protection of primary structural frame other than columns. Members of the primary structural frame other than columns that are required to have protection to achieve a fire-resistive rating and support more than two floors or one floor and roof or support a load-bearing wall or a non-load bearing wall more than two stories high, shall be provided individual encasement protection by protecting them on all side for the full length, including connections to other structural members, with materials having the required fire-resistive rating.

Exceptions:

1. Individual encasement protection on all sides shall be permitted on all exposed sides provided the extent of the protection is in accordance with the required fire-resistive rating, as determined in Section 703.
2. Where primary structural members are enclosed within a continuous horizontal membrane of fire-resistive rated construction that is equal to or greater that required by other sections of this code, shall not be required to be individually encased on any side of the primary structural member, including connections

Reason:

The reason for the requested change to the language of the section in question is that if the membrane enclosure is constructed to the established tested assembly then any structural member, whether primary or secondary would be protected by that tested assembly. It seems redundant to have a horizontal membrane from a tested assembly and to then include an additional level of protection that would exceed the required rating for the structural members contained within the tested horizontal membrane assembly.

As an example of an actual construction project, the floor/ceiling assembly of an A-3 occupancy and an R-2 occupancy is constructed of a primary steel frame system with horizontal beams connected to the steel columns. Either with a top bearing hanger framing system or a bottom chord bearing system, are placed wood trusses that support the floor sheathing with a finish topping of concrete along with a ceiling assembly of resilient channels and appropriate gypsum board ceiling. This is a very common floor/ceiling assembly type that has been tested by many agencies.

The issue of requiring a separate encasement of the individual primary structural members in these situations is illogical.

The reason for that statement is the fact the with or without the separate encasement protection as required by the current code, the wood framing members that are supporting the floor surface that the occupants would be walking on would be destroyed by the fire that has penetrated the one-hour rated assembly before the primary framing system has failed.

Cost Impact

The code change proposal will decrease the cost of construction .

The relative impact of the cost of construction in these cases would be appreciable to the client and the contractor. For example if you consider a situation where you are creating a 1-hour rated horizontal membrane cavity that supports a floor that is constructed of a mixed material f wood and steel that is supporting 3 - 4 floors above that level, you not only have to create the horizontal membrane that meets the tested assembly but you also have to completely encase the individual primary members as well. If this suggested change is approved then the need for the additional encasement eliminated and so is the cost.

Internal ID: 1792

FS8-18

IBC: 704.6.1 (New)

Proponent: Crystal Sujeski, representing Crystal Sujeski (crystal.sujeski@fire.ca.gov)

2018 International Building Code

704.6 Attachments to structural members. The edges of lugs, brackets, rivets and bolt heads attached to structural members shall be permitted to extend to within 1 inch (25 mm) of the surface of the fire protection.

Add new text as follows:

704.6.1 Secondary (non-structural) attachments to structural members. Where primary and secondary structural steel members require fire protection, secondary (non-structural) tubular steel attachments to those structural members shall be protected with the same fire resistive rating as required for the structural member. The protection shall extend from the structural member a distance of not less than 12 inches. An open tubular attachment shall be filled with an equivalent fire protection method for a distance of 12-inch length from the structural member, or the entire length of the open tube, whichever is less.

Reason:

Primary structural frame members shall comply with Table 601 for fire resistance rating. Secondary (non-structural) steel tubes provide support for a building's exterior curtain wall and are thereby considered to be unrated members that do not require any fire protection. The connection of non-structural tubes to primary structural members has potentially adverse thermal effects on the required fire resistance rating of the primary steel frame members.

Building attachments for miscellaneous non-structural items (hangers, braces, framing tracks, erection lifting lugs, wall supports, etc.) are typically not required to be individually fire protected. In addition, fire resistance rated assemblies are tested without attachments, and with a homogeneous and continuous protection system or material. Thus, rated assemblies are explicitly limited to only the tested or approved components given in the published listing, which does not include bare steel attachments or discontinuous member protection. If such secondary steel attachments are connected to a fire resistance rated steel assembly, they may jeopardize the assembly's rating and protection system by the introduction of "thermal shorts", which can cause unexpected and excessive heat conduction, convection, or radiation through the attachment or its connection to the primary assembly.

The proposal to require a 12-inch extension of fireproofing on all non-structural attachments is based on a general industry practice as described in ANSI/UL 263 BXUV (exhibit C). Attached in the documentation is exhibit A, a letter from Steve Unser, a chief building official from the City of Creve Coeur, MO stating a policy to address the "12- inch rule" of fireproofing structural attachments to fireproofed beams and columns.

Moreover, in cases where an open tubular steel connection is utilized it is vital that the interior surfaces of the tube walls are fireproofed and the bottom ends of the tubes are closed. Without this protection, this condition results in bare (unprotected) steel areas at the attachment that could be directly exposed to radiant and convective heat from a fire source.

Attached (exhibit B1 and B2) is a modeling analysis of a high-rise project in Stockton, CA prepared by Jensen Hughes Senior Engineers Nestor Iwankiw and Thomas Forsythe. Their analysis further supports the proposed code change that would require fire proofing of secondary non-structural attachments.

Under the current code, fire-proofing requirements for non-structural attachments and their connections remain ambiguous. This lack of clarity makes fire protection enforcement difficult due to increased construction costs for contractors, builders and owners. Furthermore, special inspectors, fire and building officials are not taught to look for these deficiencies, resulting in numerous buildings with unprotected steel that can potentially have serious implications on public safety and welfare.

The proposal establishes a legal basis for requiring the additional fire protection as described herein.

The 'attached' documentation can be viewed at this link established 2/21/18

https://www.dropbox.com/sh/t0hlmrxf63gejfh/AABEvqgYih_QPK928kuUwazKa?dl=0

Cost Impact

The code change proposal will increase the cost of construction .

This code change will increase the cost of construction; however, without additional fire protection the structural integrity of the building may be compromised.

Internal ID: 1476

FS9-18

IBC: TABLE 601, 704.11

Proponent: Jonathan Siu, City of Seattle Department of Construction and Inspections, representing Washington Association of Building Officials Technical Code Development Committee (Jon.Siu@seattle.gov)

2018 International Building Code

Revise as follows:

**TABLE 601
FIRE-RESISTANCE RATING REQUIREMENTS FOR BUILDING ELEMENTS (HOURS)**

BUILDING ELEMENT	TYPE I		TYPE II		TYPE III		TYPE IV	TYPE V	
	A	B	A	B	A	B	HT	A	B
Primary structural frame ^f (see Section 202)	3 ^{a, b}	2 ^{a, b}	1 ^b	0	1 ^b	0	HT	1 ^b	0
Bearing walls and elements supporting primary or secondary structural frame members Exterior ^{e, f} Interior	3 3 ^a	2 2 ^a	1 1	0 0	2 1	2 0	2 1/HT	1 1	0 0
Nonbearing walls and partitions Exterior	See Table 602								
Nonbearing walls and partitions Interior ^d	0	0	0	0	0	0	See Section 2304.11.2	0	0
Floor construction and associated secondary members (see Section 202)	2	2	1	0	1	0	HT	1	0
Roof construction and associated secondary members (see Section 202)	1 ^{1/2} ^b	1 ^{b, c}	1 ^{b, c}	0 ^c	1 ^{b, c}	0	HT	1 ^{b, c}	0

For SI: 1 foot = 304.8 mm.

- a. Roof supports: Fire-resistance ratings of primary structural frame and bearing walls are permitted to be reduced by 1 hour where supporting a roof only.
- b. Except in Group F-1, H, M and S-1 occupancies, fire protection of structural members in roof construction shall not be required, including protection of primary structural frame members, roof framing and decking where every part of the roof construction is 20 feet or more above any floor immediately below. Fire-retardant-treated wood members shall be allowed to be used for such unprotected members.
- c. In all occupancies, heavy timber complying with Section 2304.11 shall be allowed where a 1-hour or less fire-resistance rating is required.
- d. Not less than the fire-resistance rating required by other sections of this code.
- e. Not less than the fire-resistance rating based on fire separation distance (see Table 602).
- f. Not less than the fire-resistance rating as referenced in Section 704.10.

704.11 Bottom flange protection-Lintels, shelf angles, and plates. ~~Fire protection is not required at the bottom flange of lintels, shelf angles and plates, spanning not more than 6 feet 4 inches (1931 mm) whether part of the primary structural frame or not, and from the bottom flange of lintels, shelf angles and plates not part of the structural frame, regardless of span.~~

Fire protection shall be provided at the bottom flange of lintels, shelf angles and plates, where they span more than 6 feet 4 inches (1931 mm), and are an element of the structural frame.

Reason:

The first portion of this proposal is intended to clarify the requirements for fire protection of members supporting bearing walls. The second portion is partially editorial in nature, restating a requirement in the positive, rather than stating what is not required, but is also intended to be consistent with the first part of the proposal.

Table 601 regarding supporting members in bearing walls:

As currently written, the code does not address fire protection of members supporting bearing walls, whether that be bearing walls in their entirety or portions of bearing walls. This then leaves an open question for interpretation--are beams supporting bearing walls or lintels supporting portions of bearing walls considered part of the bearing wall with the associated protection, or are they primary or secondary structural frame, and protected accordingly?

The latter interpretation would be inconsistent with the code philosophy that members supporting important elements be protected to the same degree as those elements (for example, fire barriers and horizontal assemblies). On the other hand, from a structural standpoint, the former interpretation is problematic, as these members are **not** bearing walls, and therefore some would argue that the protection requirements for bearing walls do not apply.

This proposal addresses both issues. It recognizes that these structural members are going to be either primary or secondary structural frame, but requires them to be protected to the same degree as the bearing wall, consistent with code philosophy and structural understanding. The phrasing of the requirement is similar to what is used for secondary members in floor and roof construction in the same table. Locating the requirement in the text of the table as opposed to a footnote is consistent with code formatting principles of not putting significant requirements in footnotes.

Section 704.11 regarding lintels, shelf angles, and plates:

While the online Merriam-Webster dictionary broadly defines a lintel as "a horizontal architectural member spanning and usually carrying the load above an opening," our experience is the terms "lintels, shelf angles, or plates" as used in this section are generally intended to be used in the context of supporting concrete or masonry materials above.

As written, this section presumes fire protection is required for the bottom flange of lintels, shelf angles, and plates if they are part of the primary or secondary structural frame. It then goes on to say if the span is less than 6'-4", or if the element is not part of the structural frame, then protection is not required. Lintels above openings in masonry bearing walls generally are not supported on columns, and would therefore be secondary frame by definition. In accordance with this section, they are then required to be protected if they span more than 6'-4". However, Table 601 currently does not address secondary members that are supporting elements in bearing walls, as stated above.

This proposed rewrite turns the current language around to clearly state that protection is required if the span exceeds 6'-4" **and** is part of the structural frame. "Structural frame" would encompass both primary and secondary frame members. Consistent with the proposed change to Table 601, this proposal would require these lintels, shelf angles, and plates to be protected to the same degree as the wall they are supporting.

Related code change proposal:

A separate but related code change proposal has been submitted to clarify requirements for supporting fire walls and fire barriers. If this proposal and the fire wall/fire barrier proposals both pass, the combined Section 704.11 can appear as follows:

704.11 Lintels, shelf angles, and plates. Fire protection shall be provided at the bottom flange of lintels, shelf angles and plates, where they span more than 6 feet 4 inches (1931 mm) and meet at least one of the following conditions:

1. They are an element of the structural frame, or
2. They support fire wall or fire barrier construction.

Cost Impact

The code change proposal will increase the cost of construction .

Because this is a mostly a clarification of the current code language, the impact on cost of construction will depend on how a local jurisdiction is interpreting the current code provisions. If the jurisdiction is requiring fireproofing consistent with structural frame items in Table 601, this proposal could result in increased cost for providing fireproofing for beams or lintels, or for increased fireproofing materials in some cases where primary or secondary structural frame has a lower required fire-resistance rating than bearing wall rating (see Types III and IV construction). However, if the local jurisdiction already requires lintels and beams supporting bearing walls to have the same fire-resistance rating as the bearing wall they are supporting, then there will be no change in the cost of construction.

Internal ID: 581

FS10-18

IBC: SECTION 202, 202, 704.14 (New), 603.1, 722.5.2.2, 722.5.2.3

Proponent: Bill McHugh, The McHugh Company, representing National Fireproofing Contractors Association (Bill@mc-hugh.us)

2018 International Building Code

SECTION 202 DEFINITIONS

Revise as follows:

[BF] INTUMESCENT FIRE-RESISTANT COATINGS- MATERIALS. Thin film liquid mixture applied to substrates ~~by brush, roller, spray or trowel which~~, intumescent fire-resistive material expands into a protective ~~foamed~~ layer to provide fire-resistant protection of the substrates when exposed to flame or intense heat.

Add new text as follows:

704.14 Intumescent fire-resistant materials (IFRM). Intumescent fire-resistant materials (IFRM) shall be consistent with the fire-resistance rating, the listing and manufacturers installation instructions. The instructions shall include, but are not limited to, substrate condition, application temperatures, surface conditions and IFRM handling, storage, mixing, conveyance, method of application, curing and ventilation. The finished condition of IFRM applied to structural members or horizontal assemblies shall not, upon complete drying or curing, exhibit delamination.

Revise as follows:

603.1 Allowable materials. Combustible materials shall be permitted in buildings of Type I or II construction in the following applications and in accordance with Sections 603.1.1 through 603.1.3:

1. *Fire-retardant-treated wood* shall be permitted in:
 - 1.1. Nonbearing partitions where the required *fire-resistance rating* is 2 hours or less.
 - 1.2. Nonbearing *exterior walls* where fire-resistance-rated construction is not required.
 - 1.3. Roof construction, including girders, trusses, framing and decking.

Exception: In buildings of Type IA construction exceeding two *stories above grade plane*, *fire-retardant-treated wood* is not permitted in roof construction where the vertical distance from the upper floor to the roof is less than 20 feet (6096 mm).
 - 1.4. Balconies, porches, decks and exterior stairways not used as required exits on buildings three *stories* or less above grade plane.
2. Thermal and acoustical insulation, other than foam plastics, having a *flame spread index* of not more than 25.

Exceptions:

 1. Insulation placed between two layers of noncombustible materials without an intervening airspace shall be allowed to have a *flame spread index* of not more than 100.
 2. Insulation installed between a finished floor and solid decking without intervening airspace shall be allowed to have a *flame spread index* of not more than 200.
3. Foam plastics in accordance with Chapter 26.
4. Roof coverings that have an A, B or C classification.
5. *Interior floor finish* and floor covering materials installed in accordance with Section 804.
6. Millwork such as doors, door frames, window sashes and frames.
7. *Interior wall and ceiling finishes* installed in accordance with Section 803.
8. *Trim* installed in accordance with Section 806.
9. Where not installed greater than 15 feet (4572 mm) above grade, show windows, nailing or furring strips and wooden bulkheads below show windows, including their frames, aprons and show cases.
10. Finish flooring installed in accordance with Section 805.

11. Partitions dividing portions of stores, offices or similar places occupied by one tenant only and that do not establish a *corridor* serving an *occupant load* of 30 or more shall be permitted to be constructed of *fire-retardant-treated* wood, 1-hour fire-resistance-rated construction or of wood panels or similar light construction up to 6 feet (1829 mm) in height.
12. Stages and platforms constructed in accordance with Sections 410.2 and 410.3, respectively.
13. Combustible *exterior wall coverings*, balconies and similar projections and bay or oriel windows in accordance with Chapter 14 and Section 705.2.3.1.
14. Blocking such as for handrails, millwork, cabinets and window and door frames.
15. Light-transmitting plastics as permitted by Chapter 26.
16. Mastics and caulking materials applied to provide flexible seals between components of *exterior wall* construction.
17. Exterior plastic veneer installed in accordance with Section 2605.2.
18. Nailing or furring strips as permitted by Section 803.15.
19. Heavy timber as permitted by Note c to Table 601 and Sections 602.4.3 and 705.2.3.1.
20. Aggregates, component materials and admixtures as permitted by Section 703.2.2.
21. Sprayed fire-resistant materials and intumescent and mastic fire-resistant ~~coatings materials~~, determined on the basis of *fire resistance* tests in accordance with Section 703.2 and installed in accordance with Sections 1705.14 and 1705.15, respectively.
22. Materials used to protect penetrations in fire-resistance-rated assemblies in accordance with Section 714.
23. Materials used to protect joints in fire-resistance-rated assemblies in accordance with Section 715.
24. Materials allowed in the concealed spaces of buildings of Types I and II construction in accordance with Section 718.5.
25. Materials exposed within plenums complying with Section 602 of the International Mechanical Code.
26. Wall construction of freezers and coolers of less than 1,000 square feet (92.9 m²), in size, lined on both sides with noncombustible materials and the building is protected throughout with an *automatic sprinkler system* in accordance with Section 903.3.1.1.

722.5.2.2 Sprayed fire-resistant materials. The provisions in this section apply to structural steel beams and girders protected with sprayed fire-resistant materials. Larger or smaller beam and girder shapes shall be permitted to be substituted for beams specified in *approved* unrestrained or restrained fire-resistance-rated assemblies, provided that the thickness of the fire-resistant material is adjusted in accordance with the following expression:

$$h_2 = h_1 [(W_1 / D_1) + 0.60] / [(W_2 / D_2) + 0.60]$$

(Equation 7-17)

where:

h = Thickness of sprayed fire-resistant material in inches.

W = Weight of the structural steel beam or girder in pounds per linear foot.

D = Heated perimeter of the structural steel beam in inches.

Subscript 1 refers to the beam and fire-resistant material thickness in the *approved* assembly. Subscript 2 refers to the substitute beam or girder and the required thickness of fire-resistant material. The *fire resistance* of structural steel beams and girders protected with intumescent or mastic fire-resistant ~~coatings materials~~ shall be determined on the basis of fire-resistance tests in accordance with Section 703.2.

722.5.2.3 Structural steel trusses. The *fire resistance* of structural steel trusses protected with fire-resistant materials sprayed to each of the individual truss elements shall be permitted to be determined in accordance with this section. The thickness of the fire-resistant material shall be determined in accordance with Section 722.5.1.3. The weight-to-heated-perimeter ratio (W/D) of truss elements that can be simultaneously exposed to fire on all sides shall be determined on the same basis as columns, as specified in Section 722.5.1.1. The weight-to-heated-perimeter ratio (W/D) of truss elements that directly support floor or roof assembly shall be determined on the same basis as beams and girders, as specified in Section 722.5.2.1. The *fire resistance* of structural steel trusses protected with intumescent or mastic fire-resistant ~~coatings materials~~ shall be determined on the basis of *fire resistance* tests in accordance with Section 703.2.

Reason:

There has been a section in the IBC that refers to Sprayed Fire-Resistant Materials (SFRM) for many years. Currently is no section in the IBC for a different type of material that produces the same result, Intumescent Fire-Resistant Materials (IFRM). The requirements for IFRM are as important as those for SFRM. Therefore, this section should be added to the code. The language is taken from the SFRM section and modified to fit IFRM's.

Cost Impact

The code change proposal will not increase or decrease the cost of construction .

Adding this section to the code brings another option for fire-resistance in buildings.

Internal ID: 1989

FS11-18

IBC: SECTION 202, 202 (New), 705, 705.1, 705.2, TABLE 705.2, 705.2.1, 705.2.2, 705.2.3, 705.2.3.1, 705.8.1

Proponent: Lee Kranz, City of Bellevue, representing City of Bellevue, WA (lkranz@bellevuewa.gov)

2018 International Building Code

SECTION 202 DEFINITIONS

Add new definition as follows:

OPENING EXTERIOR. Fenestration, doors, hatches, vents, intake or exhaust grilles and similar elements installed in an exterior wall or roof assembly. Portions of the building perimeter covered by roofs or stories extending beyond an exterior wall below and not provided with a physical barrier commonly considered to be an exterior wall.

Revise as follows:

705 EXTERIOR WALLS AND PROJECTIONS

705.1 General. *Exterior walls and projections* shall comply with this section.

705.2 Projections. Cornices, eave overhangs, exterior balconies, elevated floors, roof assemblies and similar projections extending beyond the exterior wall shall conform to the requirements of this section and Section 1405. Exterior egress balconies and exterior exit stairways and ramps shall comply with Sections 1021 and 1027, respectively. Projections shall not extend any closer to the line used to determine the *fire separation distance* than shown in Table 705.2.

~~Exception~~ **Exceptions:**

1. Buildings on the same lot and considered as portions of one building in accordance with Section 705.3 are not required to comply with this section for projections between the buildings.
2. Elevated floors and roof assemblies extending beyond the exterior wall shall not be considered to be projections if of Type I or Type II construction.

**TABLE 705.2
MINIMUM DISTANCE OF PROJECTION**

FIRE SEPARATION DISTANCE-FSD (feet)	MINIMUM DISTANCE FROM LINE USED TO DETERMINE FSD
0 to less than 2	Projections not permitted
3 to less than 5	24 inches plus 8 inches for every foot of FSD beyond 3 feet or fraction thereof
5 or greater	40 inches

For SI: 1 foot = 304.8 mm; 1 inch = 25.4 mm.

705.2.1 Types I and II construction. Projections ~~from extending beyond exterior walls~~ of Type I or II construction shall be of noncombustible materials or combustible materials as allowed by Sections 705.2.3.1 and 705.2.4.

705.2.2 Type III, IV or V construction. Projections ~~from extending beyond exterior walls~~ of Type III, IV or V construction shall be of any *approved* material.

705.2.3 Combustible projections. Combustible projections, including elevated roof and floor assemblies projecting beyond the exterior wall and extending to within 5 feet (1524 mm) of the line used to determine the fire separation distance shall be of not less than 1-hour *fire-resistance-rated* construction, heavy timber construction, complying with Section 2304.11, *fire-retardant-treated wood* or as permitted by Section 705.2.3.1.

Exception: Type VB construction shall be allowed for combustible projections in Group R-3 and U occupancies with a *fire separation distance* greater than or equal to 5 feet (1524 mm).

705.2.3.1 Balconies and similar projections. Balconies and similar projections of combustible construction other than fire-retardant-treated wood shall be fire-resistance rated where required by Table 601 for floor construction or shall be of heavy timber construction in accordance with Section 2304.11. The aggregate length of the projections shall not exceed 50 percent of the building's perimeter on each floor.

Exceptions:

1. On buildings of Types I and II construction, three stories or less above grade plane, fire-retardant-treated wood shall be permitted for balconies, porches, decks and exterior stairways not used as required exits.
2. Untreated wood and plastic composites that comply with ASTM D7032 and Section 2612 are permitted for pickets, rails and similar guard components that are limited to 42 inches (1067 mm) in height.
3. Balconies and similar ~~projections elements projecting from exterior walls~~ on buildings of Types III, IV and V construction shall ~~be permitted to be of Type V construction and shall not be required to have a fire-resistance rating where sprinkler protection is extended to these areas.~~
4. ~~Where sprinkler protection is extended to the balcony areas, the~~ and the aggregate length of the balcony on each floor shall not be limited where sprinkler protection is extended to these areas.

705.8.1 Allowable area of openings. The maximum area of unprotected and protected openings permitted in an *exterior wall* in any story of a building shall not exceed the percentages specified in Table 705.8 based on the *fire separation distance* of each individual story.

Exceptions:

1. In other than Group H occupancies, unlimited unprotected openings are permitted in the first story above grade plane where the wall faces one of the following:
 - 1.1. A street and has a *fire separation distance* of more than 15 feet (4572 mm).
 - 1.2. An unoccupied space. The unoccupied space shall be on the same lot or dedicated for public use, shall be not less than 30 feet (9144 mm) in width and shall have access from a street by a posted fire lane in accordance with the International Fire Code.
2. Buildings whose exterior bearing walls, exterior nonbearing walls and exterior primary structural frame are not required to be fire-resistance rated shall be permitted to have unlimited unprotected openings.

Reason:

FS17-15 was approved for the 2018 IBC. It makes it clear that fire separation distance must be measured from the property line to the physical exterior wall, even if it is located a significant distance back under a story or roof projecting beyond the exterior wall (visualize an upside down wedding cake). This brought to light a basic flaw in the code related to building designs where an elevated floor or roof extends beyond the exterior wall toward the property

line. For example, under the current provisions, in a type V-B combustibile building, an upper story or roof projecting beyond the exterior wall is not limited in terms of how close it may come to the property line. Since 705.2 is intended to only address elements projecting "from an exterior wall" and not "floors or roofs extending beyond an exterior wall" the open side created by these designs is not regulated thereby creating a high potential for conflagration fires. Consistency in application of this basic code concept is critical to prevent fires from spreading from one building to another. In a recent survey of ICC plan check engineers, it was clear that the current code language does not provide clear direction on how to protect buildings when elevated floors or roofs extend beyond the exterior wall. If this proposal is approved it will provide the needed direction and create consistency in application.

FS17-15

705.8.1

Proposed Change as Submitted

Proponent : Stephen Thomas, representing Colorado Chapter (sthomas@coloradocode.net)

2015 International Building Code

Revise as follows:

705.8.1 Allowable area of openings. The maximum area of unprotected and protected openings permitted in an exterior wall in any story of a building shall not exceed the percentages specified in Table 705.8 based on the fire separation distance of each individual story.

Exceptions:

1. In other than Group H occupancies, unlimited unprotected openings are permitted in the first story above grade plane either:
 - 1.1. Where the wall faces a street and has a fire separation distance of more than 15 feet (4572 mm); or
 - 1.2. Where the wall faces an unoccupied space. The unoccupied space shall be on the same lot or dedicated for public use, shall be not less than 30 feet (9144 mm) in width and shall have access from a street by a posted fire lane in accordance with the International Fire Code.
2. Buildings whose exterior bearing walls, exterior nonbearing walls and exterior primary structural frame are not required to be fire-resistance rated shall be permitted to have unlimited unprotected openings.

Reason: The intent of this change is to clarify that the limitation of openings in exterior walls is based on the fire separation distance of each individual story. There appears to be confusion on how to evaluate openings in exterior walls when an upper floor extends out over a lower floor. We believe that the opening protection is determined at the exterior wall of the story, not the wall plane of the story above. Just the opposite would be true if the building was a pyramid style building where the upper floors step back from the floor below. The opening protection would depend on the distance to the lot line at each story, not the first story. Please see attached diagrams.

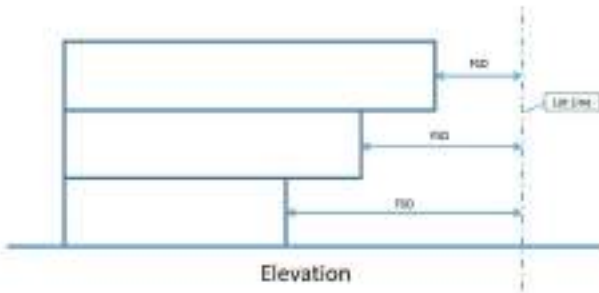
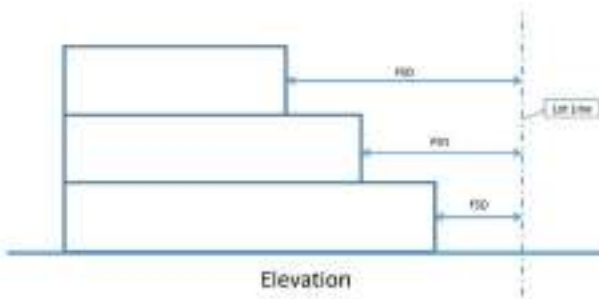

Cost Impact: Will not increase the cost of construction
 The change clarifies the intent of the code. There is no effect on the construction cost.

FS17-15 | 705.8.1-
 73026/6448

Public Hearing Results

Committee Action: **Approved as Submitted**

Committee Reason: The committee agreed that this proposal clarifies that the limitation of openings in exterior walls is based on the fire separation distance of each individual story, rather than only based on the FSD of the first story.

Individual Consideration Agenda**Public Comment 1:**

Proponent : Ali Fattah, City of San Diego Development Services, representing City of San Diego (afattah@sandiego.gov) requests Disapprove.

Commenter's Reason: We urge disapproval of this code change. The proposed code change was approved by the committee in lieu of PS 16 even though they addressed two different issues. PS 17 addresses the method of measurement. PS 18 address the hazards of usable space under a story of a building that is larger than the story below.

The definition of fire separation distance in Section 202 is a measurement from the building face and is a method of measurement to a reference point whether a lot line or an imaginary line. It stands to reason that if the code intent is for a lot line or imaginary line to be vertical that there should be one line used for measurement purposes. When the term is used the code intends it to be used as a measurement to the same reference so the code change is not necessary. The code change however has a negative consequence and reduces fire protection without technical justification. Additionally the definition add in PS 11 may lead to the portion of the upper story projecting beyond the lower smaller story a projection.

Additionally Section 705.5 and 705.8.1 makes clear that the area measurement for openings is per story based on the fire separation distance (which is to the building face). Evaluation of the inverted wedding cake scenario should be evaluated on a case by case basis and this code change does not allow for that. PS 18 was addressing an issue that Section 705.5 and Table 602 never require an exterior wall but tell when an exterior wall needs to be fire resistance rated based on occupancy, type of construction and fire separation distance. An exterior wall should be required to protect a neighboring property from the hazards of an occupancy and its fire loading. PS 17 would allow a upper story located 6 inches from a lot line with no exterior wall openings to have a story below with no exterior wall with occupants able to touch the neighboring property's fence or event the exterior wall.

Public Comment 2:

Proponent : Lee Kranz, City of Bellevue, WA , representing Washington Association of Building Officials Technical Code Development Committee (lkranz@bellevuewa.gov) requests Disapprove.

Commenter's Reason: The image below, which was provided in the proponent's original reason statement, shows a multi-story building with upper levels extending closer to the property line than the lower levels. In many cases, areas located below the upper levels would count as floor area based on the definition of Building area. The text in this definition states that "Areas of the building not provided with surrounding walls shall be included in the building area if such areas are included within the horizontal projection of the roof or floor above". There have been many case studies of configuration fires due to radiant heat transferring from one building to the projecting horizontal surfaces of another building if that building is located too close to the property line and has not been provided with rated exterior walls and protected openings at the outboard edge of the overhang. This code change also does not address exterior wall and opening protection for

structures with no exterior walls such as carports (see carport illustrations below). Does constructing a wall below the edge of a carport roof on the side opposite to the property line setback change the way fire would spread from one parcel improvement to the other? Based on this code change, constructing such a wall would allow the open side of the carport to extend all the way to the property line because the setback to the exterior wall would be on the side opposite of the open carport roof edge. This code change has potentially dangerous consequences and should not be approved.

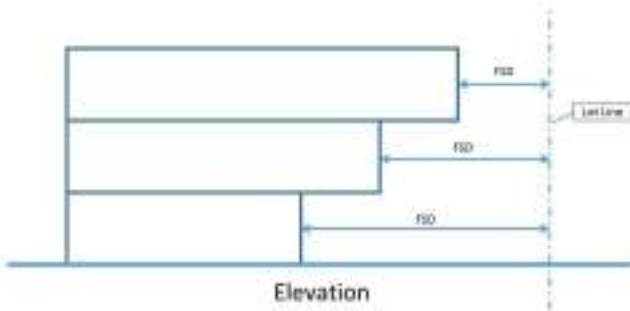

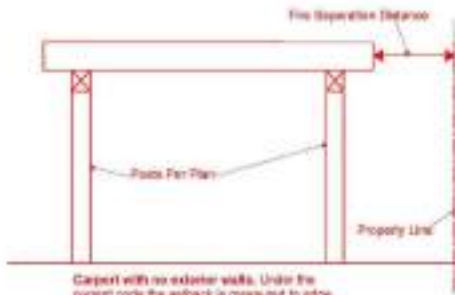

Canopy with no exterior walls. Under the current code the setback is measured to edge of wall based on definition of "Building Area" and "Fire Separation Distance".

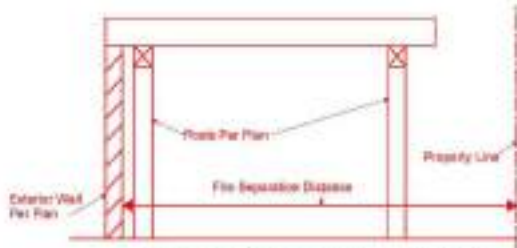

Canopy with exterior wall. The proposed code change would allow the setback to be measured to the exterior wall instead of the opposite side of the canopy. This could result in the roof edge having a zero setback without a (rated exterior) wall or opening protective adjacent to the property line.

PS17-15

Cost Impact

The code change proposal will increase the cost of construction .

There may be cases where additional fire protection assemblies will be required on the open sides of buildings having overhanging floors or roofs that extend beyond the exterior wall of a floor below.

Internal ID: 92

FS12-18

IBC: 705, 705.1, 705.2, 705.2.4 (New)

Proponent: Lee Kranz, City of Bellevue, WA, representing Washington Association of Building Officials Technical Code Development Committee (lkranz@bellevuewa.gov)

2018 International Building Code

Revise as follows:

SECTION 705 EXTERIOR WALLS AND PROJECTIONS

705.1 General. Exterior walls and projections shall comply with this section.

705.2 Projections. Cornices, roof and eave overhangs, projecting floors above, exterior balconies and similar projections extending beyond the exterior wall shall conform to the requirements of this section and Section 1405. Exterior egress balconies and exterior exit stairways and ramps shall comply with Sections 1021 and 1027, respectively. Projections shall not extend any closer to the line used to determine the *fire separation distance* than shown in Table 705.2.

Exception-Exceptions:

1. Buildings on the same lot and considered as portions of one building in accordance with Section 705.3 are not required to comply with this section for projections between the buildings.
2. Projecting floors complying with Section 705.2.4 are not required to comply with the projection limitations of Table 705.2.

Add new text as follows:

705.2.4 Projecting floors. Where the fire separation distance on a lower floor is greater than the fire separation distance on the floor immediately above, the projecting floor shall have the same fire-resistance rating as the exterior wall above based on Table 602. The fire-resistant rating of the horizontal portion shall be continuous to the lower vertical wall.

Exception:Buildings of Type I or Type II construction

Reason:

The current code does not account for a scenario where an upper floor extends closer to a lot line than the floor below. There is direction that indicates that fire separation distance will be measured to the face of the exterior wall on each floor level separately. This could create an unsafe condition where a lower floor has less stringent requirements than a floor/ceiling assembly and wall above, and fire may be able to propagate through roll out from the lower floor.

This situation is similar to the flame spread conditions of projections. Including projecting floors as projections will help limit the dangers by making the floor above meet the projection requirements. The exception allows for the projections table to not apply where the horizontal surface is given the same fire-resistant rating as the more hazardous wall above.

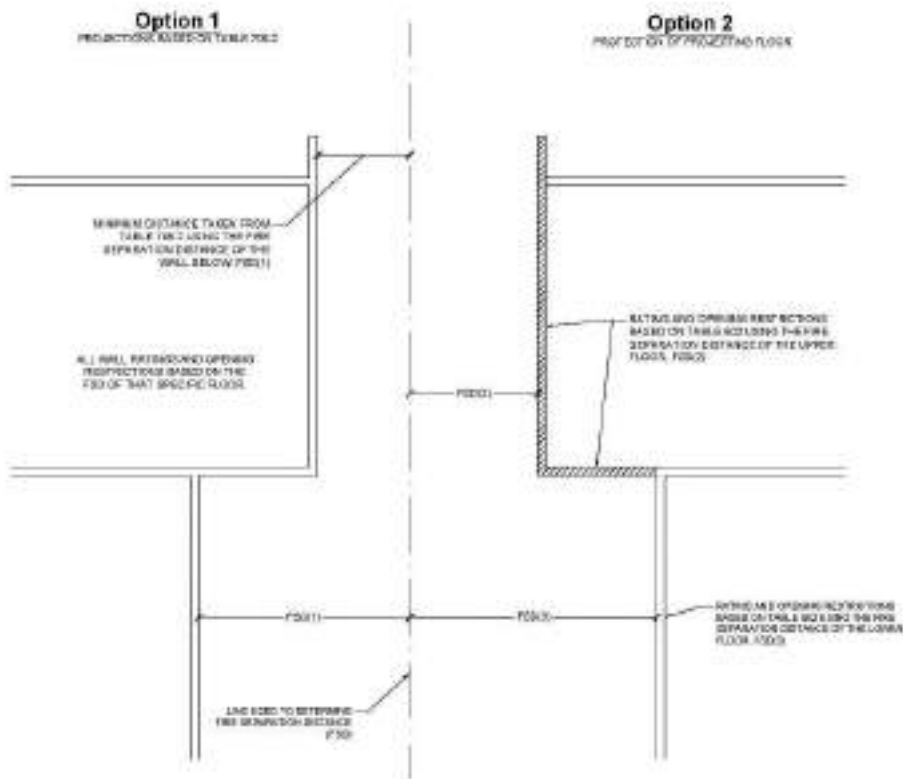

Cost Impact

The code change proposal will increase the cost of construction .

There will be no change in the cost of construction for Type I and II buildings. For other types the cost to install fire resistance rated soffit materials for projecting floors will increase the cost of construction.

Internal ID: 416

FS13-18

IBC: 705.1, 705.2

Proponent: Stephen Thomas, Colorado Code Consulting, LLC, representing Himself (sthomas@coloradocode.net)

2018 International Building Code

Revise as follows:

705.1 General. *Exterior walls* shall comply with this section and Section 1405.

705.2 Projections. Cornices, eave overhangs, exterior balconies and similar projections extending beyond the exterior wall shall conform to the requirements of this section. ~~and Section 1405~~. Exterior egress balconies and exterior exit stairways and ramps shall comply with Sections 1021 and 1027, respectively. Projections shall not extend any closer to the line used to determine the *fire separation distance* than shown in Table 705.2.

Exception: Buildings on the same lot and considered as portions of one building in accordance with Section 705.3 are not required to comply with this section for projections between the buildings.

Reason:

Section 1405 is titled "Combustible materials on the exterior side of exterior walls". There is no language in that section that discusses projections. Therefore, the cross reference in Section 705.2 which relates to projections is not in the correct place. So, I relocated the cross reference to the General Section 705.1. It could be argued that Section 1405 should be relocated to Section 705 since it has to do with the fire characteristics of exterior walls. I will let the committee decide whether that is appropriate. This change is just to make sure the reference is in the correct location.

Cost Impact

The code change proposal will not increase or decrease the cost of construction .

The change is a clarification and does not change any technical requirements.

Internal ID: 1857

FS14-18

IBC: TABLE 705.2

Proponent: Todd Snider, West Coast Code Consultants (WC3), representing Self (Todd@KimballEng.com)

2018 International Building Code

Revise as follows:

TABLE 705.2
MINIMUM DISTANCE OF PROJECTION

FIRE SEPARATION DISTANCE-FSD (feet)	MINIMUM DISTANCE FROM LINE USED TO DETERMINE FSD
0 to less than 2	Projections not permitted
2 to less than 3	24 inches
3 to less than 5	24 inches plus 8 inches for every foot of FSD beyond 3 feet or fraction thereof <u>$\frac{2}{3}$ the FSD</u>
5 or greater	40 inches

For SI: 1 foot = 304.8 mm; 1 inch = 25.4 mm.

Reason:

Proposed revision to change the step function for determining distance from line used to determine FSD. From 0 to 3 feet the code requires a lengthy equation which states that a 24 inch separation plus 8 inches for every foot of FSD beyond 3 feet or fraction thereof. This equation is complicated and is not very helpful when the line used for determining FSD is not parallel to the exterior wall. For example take a wall where the FSD increases from 3 feet at one end of the wall to 5 feet at the far end of the wall. At three feet the separation requires is 24 inches which allows a 12 inch projects. As the FSD increases to say 3'-1", this would require a separation of 24 inches plus 8 inches which is 32 inches of separation which reduces the projection to 5 inches. The FSD has increased but the size of the projection has decreased. A 12 inch projection is not allowed again until the FSD reaches 3'-8". Then the projection will increase to 16 inches at a FSD of 4 feet. As the FSD continues to increase at 4'-1" the allowed projection will reduce to 9 inches (49"-24"-2*8" = 40" separation), which is again not only less than what was permitted at 4 feet FSD but also less than what was allowed with only a 3 foot FSD. A 16 inch projection will not be allowed again until 4'-8" FSD. At which time separation is set at 40 inches and the size of the projection increases at the same rate as the FSD increases. The solution is to provide a linear equation to determine the separation distance. $\frac{2}{3}$ of the FSD.

Cost Impact

The code change proposal will not increase or decrease the cost of construction .

This code change has no cost affect. It will just simplify the determination for distance of projections to FSD.

Internal ID: 1275

FS15-18

IBC: SECTION 202, 202 (New), 705.2, TABLE 705.2, 705.2.1, 705.2.2, 705.2.3, 705.2.3.1, 705.3

Proponent: Stephen Thomas, Colorado Code Consulting, LLC, representing Himself (sthomas@coloradocode.net)

2018 International Building Code

SECTION 202 DEFINITIONS

Add new definition as follows:

BUILDING PROJECTION. An unenclosed floor, roof or appendage extending beyond the exterior wall of a building such as, but not limited to cornices, eave overhangs, exterior decks or balconies, porte cocheres and similar protrusions.

Revise as follows:

~~705.2 Projections.~~Building projections. ~~Cornices, eave overhangs, exterior balconies and similar projections extending beyond the exterior wall~~Building projections shall conform to the requirements of this section and Section 1405. Exterior egress balconies and exterior exit stairways and ramps shall comply with Sections 1021 and 1027, respectively. ~~Projections~~Building projections shall not extend any closer to the line used to determine the *fire separation distance* than shown in Table 705.2.

Exception: Buildings on the same lot and considered as portions of one building in accordance with Section 705.3 are not required to comply with this section for projections between the buildings.

TABLE 705.2
MINIMUM DISTANCE OF BUILDING PROJECTION

FIRE SEPARATION DISTANCE-FSD (feet)	MINIMUM DISTANCE FROM LINE USED TO DETERMINE FSD
0 to less than 2	Projections not permitted
2 to less than 3	24 inches
3 to less than 5	24 inches plus 8 inches for every foot of FSD beyond 3 feet or fraction thereof
5 or greater	40 inches

For SI: 1 foot = 304.8 mm; 1 inch = 25.4 mm.

705.2.1 Types I and II construction. ~~Projections~~ Building projections from walls of Type I or II construction shall be of noncombustible materials or combustible materials as allowed by Sections 705.2.3.1 and 705.2.4.

705.2.2 Type III, IV or V construction. ~~Projections~~ Building projections from walls of Type III, IV or V construction shall be of any *approved* material.

705.2.3 Combustible building projections. Combustible building projections extending to within 5 feet (1524 mm) of the line used to determine the *fire separation distance* shall be of not less than 1-hour *fire-resistance-rated* construction, heavy timber construction, complying with Section 2304.11, *fire-retardant-treated wood* or as permitted by Section 705.2.3.1.

Exception: Type VB construction shall be allowed for combustible projections in Group R-3 and U occupancies with a *fire separation distance* greater than or equal to 5 feet (1524 mm).

705.2.3.1 Balconies and similar projections. Balconies, decks and similar building projections of combustible construction other than fire-retardant-treated wood shall be fire-resistance rated where required by Table 601 for floor construction or shall be of heavy timber construction in accordance with Section 2304.11. The aggregate length of the projections shall not exceed 50 percent of the building's perimeter on each floor.

Exceptions:

1. On buildings of Types I and II construction, three stories or less above grade plane, fire-retardant-treated wood shall be permitted for balconies, porches, decks and exterior stairways not used as required exits.
2. Untreated wood and plastic composites that comply with ASTM D7032 and Section 2612 are permitted for pickets, rails and similar guard components that are limited to 42 inches (1067 mm) in height.
3. Balconies, decks and similar projections on buildings of Types III, IV and V construction shall be permitted to be of Type V construction and shall not be required to have a *fire-resistance rating* where sprinkler protection is extended to these areas.
4. Where sprinkler protection is extended to the balcony or deck areas, the aggregate length of the balcony on each floor shall not be limited.

705.3 Buildings on the same lot. For the purposes of determining the required wall and opening protection, building projections and roof-covering requirements, buildings on the same lot shall be assumed to have an imaginary line between them.

Where a new building is to be erected on the same lot as an existing building, the location of the assumed imaginary line with relation to the existing building shall be such that the *exterior wall* and opening protection of the existing building meet the criteria as set forth in Sections 705.5 and 705.8.

Exceptions:

1. Two or more buildings on the same lot shall be either regulated as separate buildings or shall be considered as portions of one building if the aggregate area of such buildings is within the limits specified in Chapter 5 for a single building. Where the buildings contain different occupancy groups or are of different types of construction, the area shall be that allowed for the most restrictive occupancy or construction.
2. Where an S-2 parking garage of Construction Type I or IIA is erected on the same lot as a Group R-2 building, and there is no *fire separation distance* between these buildings, then the adjoining *exterior walls* between the buildings are permitted to have occupant use openings in accordance with Section 706.8. However, opening protectives in such openings shall only be required in the exterior wall of the S-2 parking garage, not in the exterior wall openings in the R-2 building, and these opening protectives in the exterior wall of the S-2 parking garage shall be not less than 1¹/₂-hour *fire protection rating*.

Reason:

The committee felt that a definition for building projections would be helpful in the administering of the code. We submitted a public comment and received opposition to the revised language. We have taken the comments from the committee hearing and the public comment hearing and created this proposal. There is quite a bit of confusion as to

what a projection is. We have provided guidance and examples of what we feel are projections. The term unenclosed floors is intended to keep from having an upper story that is enclosed from being called a projection. Decks and balconies would be examples of unenclosed floors.

We have also changed the term 'Projection' to 'Building Projection' to differentiate this definition from other sections of the code that use similar language. For example, projection rooms and projections into ramps. It is not our intent to apply this definition to those sections of the code. The rest of the change involves coordinating the existing language with the new definition.

The fire characteristics are different for projections than they are for horizontal assemblies within a building. First, there is no enclosed space above the projection. The second is that the heat and smoke from a fire under a projection will go up and then out to the atmosphere. The heat and smoke is not trapped within a room like it is within a building. That is why I believe projections are handled differently in the code.

The photo below is the porte cochere entry at the City Center project in Clark County, Nevada. The question is what is this structure. Is it a projection that is regulated by Section 705.2 or is a building element regulated by Table 601. That is the question I am trying to clarify in the code. This change would clarify that this structure would be a projection and would need to comply with Section 705.2.



Cost Impact

The code change proposal will not increase or decrease the cost of construction .

This is a clarification of the current code.

Internal ID: 1468

FS16-18

IBC: 705.2.3

Proponent: Stephen Thomas, Colorado Code Consulting, LLC, representing Himself (sthomas@coloradocode.net)

2018 International Building Code

Delete and substitute as follows:

~~**705.2.3 Combustible projections.** Combustible projections extending to within 5 feet (1524 mm) of the line used to determine the *fire separation distance* shall be of not less than 1-hour *fire resistance rated* construction, heavy timber construction, complying with Section 2304.11, *fire-retardant treated wood* or as permitted by Section 705.2.3.1.~~

~~**Exception:** Type VB construction shall be allowed for combustible projections in Group R-3 and U occupancies with a *fire separation distance* greater than or equal to 5 feet (1524 mm).~~

705.2.3 Projection Protection. Projections extending to within 5 feet (1524 mm) of the line used to determine the fire separation distance shall be one of the following:

1. Noncombustible materials.
2. Combustible materials of not less than 1-hour fire resistance rated construction.
3. Heavy timber construction complying with Section 2304.11.
4. Fire-retardant treated wood.
5. As permitted by Section 705.2.3.1.

Exception: Type VB construction shall be allowed for combustible projections in Group R-3 and U occupancies with a *fire separation distance* greater than or equal to 5 feet (1524 mm).

Reason:

The current language in this section is limited to combustible projections. There is no language in the code that tells the user what to do if they are using noncombustible materials in a Type I or II building. The current language would apparently allow that noncombustible projection to go right up to the lot line. So, I have deleted the word combustible in the section so that it would apply to all types of projections regardless of the materials used. I have also added noncombustible materials to the items permitted to go into the 5-foot limitation. The previous language would not permit noncombustible projections into the five-foot limitation because it wasn't listed. So, this change will address that issue as well. This change also puts the requirements into a list which we have found makes the code easier to use. This change does not change the overall requirement. I believe it clarifies the code and gives better direction to the user of the code.

Cost Impact

The code change proposal will not increase or decrease the cost of construction.

This is intended to be a clarification of the code, not a change to the technical requirements.

Internal ID: 1683

FS17-18

IBC: 705.2.5 (New)

Proponent: Matthew Dobson, representing Suburban Exterior Fire Work Group; Richard Swan, International Association of Fire Fighters, representing International Association of Fire Fighters (rswan@iaff.org)

2018 International Building Code

Add new text as follows:

705.2.5 Protected soffit. In Group R buildings of Type V construction a protected soffit or fireblocking shall be provided above doorways in exterior walls. It shall extend horizontally 5 feet in both directions measured from the outside edge of the door frame. A protected soffit shall not be required where noncombustible wall cladding is installed from grade to not less than 10 feet above grade.

Soffit protection shall be applied to the horizontal underside of the roof framing members or fireblocking shall be provided in accordance with Section 718.2.1. Soffit protection shall consist of not less than one of the following materials:

1. 5/8 inch exterior grade gypsum board.
2. 1/4 inch Fiber-cement board.
3. 23/32 inch plywood.
4. 23/32 inch OSB.
5. 7/16 inch OSB Fire retardant treated wood.

Enclosed soffits shall be constructed as ventilated spaces in accordance with Section 1202.2 or unvented assemblies in accordance with Section 1202.3. Soffit panels shall be vinyl, wood structural panel, aluminum, fiber cement, or other approved soffit materials.

Reason:

Over the past code cycles there has been concern over smoker habits, combustible mulch, and the potential hazard they pose with combustion of exterior walls. The Suburban Exterior Fire Work Group, a group of fire service members, UL fire fighter safety institute, and other material stakeholders has been focused on this issue over the past 18 months.

The problem identified is the spread of fire from the exterior into to the unprotected attic space and then spreading quickly to other parts of the building.

The group has taken a 3 prong approach to address the issue:

Regulate the human risk by prohibiting smoking near exterior doors.

Remove combustible material/mulch from near the outside of combustible wall assemblies.

Create a block to slow down any fires that occur in the above described setting.

The proposed protected soffit approach will require a form of blocking outside of exterior doorways and garage doors. These proposed material have been required in North Carolina for over 5 years and are accepted to provide some form of blocking that will slow down the movement of fire from the outside to the attic space, effectively helping to address the issue and allow fire service more time put out the fire. Testing on these protected soffits are currently underway to show the effectiveness of these assemblies both vented and unvented.

Over the decade, fire departments in the Washington, DC region have been confronted with structure fires which have demonstrated a consistent pattern of starting on the outside. These fires have the potential for rapid loss of structural integrity and catastrophic collapse before occupants are alerted. As attention has grown locally, it is apparent that this type of fire is becoming common on a national basis.

These fires tend to follow a distinct pattern. These fires start at a low point on the exterior and spread vertically along the exterior wall producing flammable gases, which are readily admitted into the attic area through ventilation soffits. If not cooled, these heated gases accumulate and combust, creating rapidly spreading fire conditions in the attic area, often without occupant awareness. The unchecked fire often results in full roof involvement, creating a dangerous and difficult situation for occupants and fire fighters.

The group examined a number of structure fires which have exhibited the pattern described above. There is agreement over 3 common aspects. First, these fires often result from careless smoking habits. Second, when the smoking materials are not properly disposed of, they often come into contact with combustible materials adjacent to a building and, very commonly, this is mulch. And, last, the combustible exterior wall is a factor in the the growth of these fires into the attic space.

The careless smoker is an impediment to effective fire prevention efforts. The fire service has consistently provided data that shows smoking is the leading cause of fatal fires in the United States. Public fire and life safety efforts have been reasonably effective at communicating the message to not smoke in bed, and various medical organizations have demonstrated the health risk associated with “second hand” smoke. We now see that people are routinely smoking outside, at or near the entrance to a building, which increases the possibility of an accidental ignition of outside combustibles. If one were to chronicle the actions of today’s smoker, it would likely show the last action they take when exiting a building is to “light up.” When returning inside, they often drop the cigarette near the entrance. Many smokers seem to believe that dropping a match or cigarette onto the ground or into a flower pot is an effective method of extinguishment, however, this behavior often places the smoking material directly into the mulch, initiating the low fire described earlier.

Mulch has become a common exterior decorative material which aids in suppressing weed growth while enhancing a building’s curb appeal. However, most mulch is a dead organic material, comprised of chipped wood, tree bark or pine needles. Mulch is most effective when it is maintained in a moist state, however it can dry out very quickly and become a readily ignitable fuel source. Because of its relatively small mass in comparison to its surface area, when ignited, it will progress and sustain open flame.

The group discussed a method in which to proceed, the interest being to address, in the quickest manner, industrial and social changes which could reduce the possibility of a fire on the outside of a building. Each aspect presents unique challenges for fire prevention efforts:

1. Changing the behavior of the smoker is an ongoing and difficult challenge, especially as social pressures have resulted in regulatory changes to require people to smoke outside of a building. Further development of the “fire safe” cigarette, by way of testing using mulch, could be deemed too costly for the industry, and would have no effect on improper disposal of matches. Thus, the quickest and most practical strategy for this aspect of the problem is to expand public fire and life safety education to focus on the hazards of improper disposal of smoking materials, coupled with enforcement of applicable requirements for regulation of smoking and disposal of products. However, in this age of “information overflow” it is questionable if this would result in widespread behavioral changes for smokers;
2. Regulating the use and placement of mulch, that the study group believes could have the quickest and most significant impact toward reducing the exterior fire problem, while additional strategies to address the other problems noted are pursued.

The use of wood and wood related mulch for building decoration is purely optional. It is not a required construction component under current building codes. Therefore, regulations to curtail its use or require that it be separated from a building’s combustible exterior are reasonable and could be codified on a national basis. On a large scale, the mere action of creating separation of combustible materials has been a wildland fire tactic for years. Several states and local jurisdictions have already employed this theory by either recommending or requiring that wood-based mulch be separated from exterior combustible walls:

1. The Virginia Department of Forestry recommends to “provide a minimum of an 18 inch clearance between landscaping mulch beds and combustible building materials” and to “ensure proper clearance to electric devices, such as decorative lights, by following the manufacturer’s instructions;”
2. In Raleigh, NC, following a disastrous fire in a multi-family building, the city passed a pine straw mulch ordinance that bans the use of pine straw as ground cover within 10 feet of multi-family dwellings. The ordinance exempts 1 and 2-family dwellings, however, the city strongly encourages these homeowners to comply with the pine straw restrictions;
3. The Commonwealth of Massachusetts prohibits the new application of mulch within 18 inches around combustible exteriors of buildings, such as wood or vinyl but not brick or concrete. Residential buildings with six units or less are exempted from this regulation, but it is recommended that all homeowners adopt these safety practices. The regulation applies to all other buildings including commercial properties.
4. Ventura County, CA prohibits mulch and wood chips within the required “defensible space” zone (which ranges from 0’ to 30’ from the exterior of a building).

This small sampling of jurisdictions has produced enough evidence to lead the study group to suggest the possible introduction of a code proposal to require separation, or non-application, of wood-based mulch in proximity to combustible exterior walls.

The proposed protected soffit approach will require a form of blocking outside of exterior doorways and garage doors. These proposed material have been required in North Carolina for over 5 years and are accepted to provide some form of blocking that will slow down the movement of fire from the outside to the attic space, effectively helping to address the issue and allow fire service more time put out the fire.

We think this approach is effective, efficient, and cost effective.

Cost Impact

The code change proposal will increase the cost of construction .

This change will add some cost to construction. However the change is designed to use potentially scrap material on site to act as blocking so cost should not be very much. There will be some labor to install the protected soffit or blocking.

Internal ID: 1058

FS18-18

IBC: 705.5, TABLE 705.5, 602.1, TABLE 601, 705.6, 402.4.2.2, 402.4.2.3, 406.5.6, 704.10, 705.11, 1510.2.4, 1020.1, 2103.1, 3103.3

Proponent: Stephen Thomas, Colorado Code Consulting, LLC, representing Colorado Chapter ICC
(sthomas@coloradocode.net)

2018 International Building Code

Revise as follows:

705.5 Fire-resistance ratings. *Exterior walls* shall be fire-resistance rated in accordance with Tables 601 and 602 and this section based on the Type of Construction and Table 705.5 and this section based on the Fire Separation Distance. The required *fire-resistance rating* of *exterior walls* with a *fire separation distance* of greater than 10 feet (3048 mm) shall be rated for exposure to fire from the inside. The required *fire-resistance rating* of *exterior walls* with a *fire separation distance* of less than or equal to 10 feet (3048 mm) shall be rated for exposure to fire from both sides.

TABLE 602.705.5**FIRE-RESISTANCE RATING REQUIREMENTS FOR EXTERIOR WALLS BASED ON FIRE SEPARATION DISTANCE^a,
d, g**

FIRE SEPARATION DISTANCE =X (feet)	TYPE OF CONSTRUCTION	OCCUPANCY GROUP H^e	OCCUPANCY GROUP F-1, M, S-1^f	OCCUPANCY GROUP A, B, E, F-2, I, Rⁱ, S-2, U^h
X < 5 ^b	All	3	2	1
5 ≤ X < 10	IA	3	2	1
	Others	2	1	1
10 ≤ X < 30	IA, IB	2	1	1 ^c
	IIB, VB	1	0	0
	Others	1	1	1 ^c
X ≥ 30	All	0	0	0

For SI: 1 foot = 304.8 mm.

- a. Load-bearing exterior walls shall also comply with the fire-resistance rating requirements of Table 601.
- b. See Section 706.1.1 for party walls.
- c. Open parking garages complying with Section 406 shall not be required to have a fire-resistance rating.
- d. The fire-resistance rating of an exterior wall is determined based upon the fire separation distance of the exterior wall and the story in which the wall is located.
- e. For special requirements for Group H occupancies, see Section 415.6.
- f. For special requirements for Group S aircraft hangars, see Section 412.3.1.
- g. Where Table 705.8 permits nonbearing exterior walls with unlimited area of unprotected openings, the required fire-resistance rating for the exterior walls is 0 hours.
- h. For a building containing only a Group U occupancy private garage or carport, the exterior wall shall not be required to have a fire-resistance rating where the fire separation distance is 5 feet (1523 mm) or greater.
- i. For a Group R-3 building of Type II-B or Type V-B construction, the exterior wall shall not be required to have a fire-resistance rating where the fire separation distance is 5 feet (1523 mm) or greater.

602.1 General. Buildings and structures erected or to be erected, altered or extended in height or area shall be classified in one of the five construction types defined in Sections 602.2 through 602.5. The building elements shall have a *fire-resistance rating* not less than that specified in Table 601 and exterior walls shall have a *fire-resistance rating* not less than that specified in Table ~~602-705.5~~. Where required to have a *fire-resistance rating* by Table 601, building elements shall comply with the applicable provisions of Section 703.2. The protection of openings, ducts and air transfer openings in building elements shall not be required unless required by other provisions of this code.

**TABLE 601
FIRE-RESISTANCE RATING REQUIREMENTS FOR BUILDING ELEMENTS (HOURS)**

BUILDING ELEMENT	TYPE I		TYPE II		TYPE III		TYPE IV	TYPE V	
	A	B	A	B	A	B	HT	A	B
Primary structural frame ^f (see Section 202)	3 ^{a, b}	2 ^{a, b}	1 ^b	0	1 ^b	0	HT	1 ^b	0
Bearing walls Exterior ^{e, f} Interior	3 3 ^a	2 2 ^a	1 1	0 0	2 1	2 0	2 1/HT	1 1	0 0
Nonbearing walls and partitions Exterior	See Table 705.5								
Nonbearing walls and partitions Interior ^d	0	0	0	0	0	0	See Section 2304.11.2	0	0
Floor construction and associated secondary members (see Section 202)	2	2	1	0	1	0	HT	1	0
Roof construction and associated secondary members (see Section 202)	1 ^{1/2} ^b	1 ^{b, c}	1 ^{b, c}	0 ^c	1 ^{b, c}	0	HT	1 ^{b, c}	0

For SI: 1 foot = 304.8 mm.

- a. Roof supports: Fire-resistance ratings of primary structural frame and bearing walls are permitted to be reduced by 1 hour where supporting a roof only.
- b. Except in Group F-1, H, M and S-1 occupancies, fire protection of structural members in roof construction shall not be required, including protection of primary structural frame members, roof framing and decking where every part of the roof construction is 20 feet or more above any floor immediately below. Fire-retardant-treated wood members shall be allowed to be used for such unprotected members.
- c. In all occupancies, heavy timber complying with Section 2304.11 shall be allowed where a 1-hour or less fire-resistance rating is required.
- d. Not less than the fire-resistance rating required by other sections of this code.
- e. Not less than the fire-resistance rating based on fire separation distance (see Table ~~602~~705.5).
- f. Not less than the fire-resistance rating as referenced in Section 704.10.

705.6 Structural stability. *Exterior walls* shall extend to the height required by Section 705.11. Interior structural elements that brace the exterior wall but that are not located within the plane of the exterior wall shall have the minimum *fire-resistance rating* required in Table 601 for that structural element. Structural elements that brace the exterior wall but are located outside of the exterior wall or within the plane of the exterior wall shall have the minimum *fire-resistance rating* required in Tables 601 and ~~602~~ 705.5 for the exterior wall.

402.4.2.2 Anchor building separation. An *anchor building* shall be separated from the *covered or open mall building* by *fire walls* complying with Section 706.

Exceptions:

1. *Anchor buildings* of not more than three stories *above grade plane* that have an occupancy classification the same as that permitted for tenants of the *mall building* shall be separated by 2-hour fire-resistance-rated *fire barriers* complying with Section 707.
2. The exterior walls of *anchor buildings* separated from an *open mall building* by an *open mall* shall comply with Table ~~602~~705.5.

402.4.2.3 Parking garages. An attached garage for the storage of passenger vehicles having a capacity of not more than nine persons and *open parking garages* shall be considered as a separate building where it is separated from the *covered or open mall building* or anchor building by not less than 2-hour *fire barriers* constructed in accordance with Section 707 or *horizontal assemblies* constructed in accordance with Section 711, or both.

Parking garages, which are separated from *covered mall buildings*, *open mall buildings* or *anchor buildings*, shall comply with the provisions of Table ~~602~~705.5.

Pedestrian walkways and tunnels that connect garages to *mall buildings* or *anchor buildings* shall be constructed in accordance with Section 3104.

406.5.6 Fire separation distance. *Exterior walls* and openings in *exterior walls* shall comply with Tables 601 and ~~602~~705.5. The distance to an adjacent *lot line* shall be determined in accordance with Table ~~602~~705.5 and Section 705.

704.10 Exterior structural members. Load-bearing structural members located within the *exterior walls* or on the outside of a building or structure shall be provided with the highest *fire-resistance rating* as determined in accordance with the following:

1. As required by Table 601 for the type of building element based on the type of construction of the building.
2. As required by Table 601 for exterior bearing walls based on the type of construction.
3. As required by Table ~~602~~705.5 for *exterior walls* based on the *fire separation distance*.

705.11 Parapets. Parapets shall be provided on *exterior walls* of buildings.

Exceptions: A parapet need not be provided on an *exterior wall* where any of the following conditions exist:

1. The wall is not required to be *fire-resistance rated* in accordance with Table ~~602~~705.5 because of *fire separation distance*.
2. The building has an area of not more than 1,000 square feet (93 m²) on any floor.

3. Walls that terminate at roofs of not less than 2-hour fire-resistance-rated construction or where the roof, including the deck or slab and supporting construction, is constructed entirely of noncombustible materials.
4. One-hour fire-resistance-rated *exterior walls* that terminate at the underside of the roof sheathing, deck or slab, provided that:
 - 4.1. Where the roof/ceiling framing elements are parallel to the walls, such framing and elements supporting such framing shall not be of less than 1-hour fire-resistance-rated construction for a width of 4 feet (1220 mm) for Groups R and U and 10 feet (3048 mm) for other occupancies, measured from the interior side of the wall.
 - 4.2. Where roof/ceiling framing elements are not parallel to the wall, the entire span of such framing and elements supporting such framing shall not be of less than 1-hour fire-resistance-rated construction.
 - 4.3. Openings in the roof shall not be located within 5 feet (1524 mm) of the 1-hour fire-resistance-rated *exterior wall* for Groups R and U and 10 feet (3048 mm) for other occupancies, measured from the interior side of the wall.
 - 4.4. The entire building shall be provided with not less than a Class B roof covering.
5. In Groups R-2 and R-3 where the entire building is provided with a Class C roof covering, the *exterior wall* shall be permitted to terminate at the underside of the roof sheathing or deck in Types III, IV and V construction, provided that one or both of the following criteria is met:
 - 5.1. The roof sheathing or deck is constructed of *approved* noncombustible materials or of *fire-retardant-treated wood* for a distance of 4 feet (1220 mm).
 - 5.2. The roof is protected with 0.625-inch (16 mm) Type X gypsum board directly beneath the underside of the roof sheathing or deck, supported by not less than nominal 2-inch (51 mm) ledgers attached to the sides of the roof framing members for a minimum distance of 4 feet (1220 mm).

[BG] 1510.2.4 Type of construction. Penthouses shall be constructed with walls, floors and roofs as required for the type of construction of the building on which such penthouses are built.

Exceptions:

1. On buildings of Type I construction, the exterior walls and roofs of penthouses with a *fire separation distance* greater than 5 feet (1524 mm) and less than 20 feet (6096 mm) shall be permitted to have not less than a 1-hour fire-resistance rating. The exterior walls and roofs of penthouses with a fire separation distance of 20 feet (6096 mm) or greater shall not be required to have a fire-resistance rating.
2. On buildings of Type I construction two stories or less in height above grade plane or of Type II construction, the exterior walls and roofs of penthouses with a *fire separation distance* greater than 5 feet (1524 mm) and less than 20 feet (6096 mm) shall be permitted to have not less than a 1-hour fire-resistance rating or a lesser fire-resistance rating as required by Table ~~602.7.05.5~~ 602.705.5 and be constructed of *fire-retardant-treated wood*. The exterior walls and roofs of penthouses with a *fire separation distance* of 20 feet (6096 mm) or greater shall be permitted to be constructed of fire-retardant-treated wood and shall not be required to have a fire-resistance rating. Interior framing and walls shall be permitted to be constructed of *fire-retardant-treated wood*.
3. On buildings of Type III, IV or V construction, the exterior walls of penthouses with a *fire separation distance* greater than 5 feet (1524 mm) and less than 20 feet (6096 mm) shall be permitted to have not less than a 1-hour fire-resistance rating or a lesser fire-resistance rating as required by Table ~~602.7.05.5~~ 602.705.5. On buildings of Type III, IV or VA construction, the exterior walls of penthouses with a *fire separation distance* of 20 feet (6096 mm) or greater shall be permitted to be of heavy timber construction complying with Sections 602.4 and 2304.11 or noncombustible construction or *fire-retardant-treated wood* and shall not be required to have a fire-resistance rating.

1020.1 Construction. Corridors shall be fire-resistance rated in accordance with Table 1020.1. The *corridor walls* required to be fire-resistance rated shall comply with Section 708 for *fire partitions*.

Exceptions:

1. A *fire-resistance rating* is not required for *corridors* in an occupancy in Group E where each room that is used for instruction has not less than one door opening directly to the exterior and rooms for assembly purposes have not less than one-half of the required *means of egress* doors opening directly to the exterior. Exterior doors specified in this exception are required to be at ground level.
2. A *fire-resistance rating* is not required for *corridors* contained within a *dwelling unit* or *sleeping unit* in an occupancy in Groups I-1 and R.
3. A *fire-resistance rating* is not required for *corridors* in open parking garages.
4. A *fire-resistance rating* is not required for *corridors* in an occupancy in Group B that is a space requiring only a single *means of egress* complying with Section 1006.2.
5. Corridors adjacent to the *exterior walls* of buildings shall be permitted to have unprotected openings on unrated *exterior walls* where unrated walls are permitted by Table ~~602-705.5~~ and unprotected openings are permitted by Table 705.8.

2103.1 Masonry units. Concrete masonry units, clay or shale masonry units, stone masonry units, glass unit masonry and AAC masonry units shall comply with Article 2.3 of TMS 602. Architectural cast stone shall conform to ASTM C1364 and TMS 504. Adhered manufactured stone masonry veneer units shall conform to ASTM C1670.

Exception: Structural clay tile for nonstructural use in fireproofing of structural members and in wall furring shall not be required to meet the compressive strength specifications. The fire-resistance rating shall be determined in accordance with ASTM E119 or UL 263 and shall comply with the requirements of Table ~~602-705.5~~.

3103.3 Location. Temporary structures shall be located in accordance with the requirements of Table ~~602-705.5~~ based on the *fire-resistance rating* of the *exterior walls* for the proposed type of construction.

Reason:

When someone looks in the Table of Contents or Index of the code for exterior walls, they are sent to Section 705. However, the requirements for the fire-resistance rating of the exterior walls are hidden back in the Type of Construction Chapter 6. Type of construction deals with the materials and fire-resistance rating of building elements based on the size of the building. Exterior wall fire-resistance ratings are based on Fire Separation Distance. These are two separate issues. Therefore, we are proposing to move Table 602 back to the appropriate Section 705 where it belongs. There is no technical change in this proposal. It is just moving the table to the proper section of the code.

Cost Impact

The code change proposal will not increase or decrease the cost of construction .

The code requirements will not change with this proposal.

Internal ID: 368

FS19-18

IBC: 705.6 (New), 705.7

Proponent: Stephen Thomas, Colorado Code Consulting, LLC, representing Colorado Chapter ICC (stthomas@coloradocode.net)

2018 International Building Code

Add new text as follows:

705.6 Continuity. The fire-resistance rating of exterior walls shall extend from the top of the foundation or floor/ceiling assembly below to one of the following:

1. The underside of the floor or roof sheathing, deck or slab above.
2. The underside of a floor/ceiling or roof/ceiling assembly having a fire-resistance rating that is not less than the fire-resistance rating of the exterior wall.

Parapets shall be provided as required by Section 705.11.

Revise as follows:

~~**705.6**~~**705.7 Structural stability.** ~~Exterior walls shall extend to the height required by Section 705.11.~~ Interior structural elements that brace the exterior wall but that are not located within the plane of the exterior wall shall have the minimum *fire-resistance rating* required in Table 601 for that structural element. Structural elements that brace the exterior wall but are located outside of the exterior wall or within the plane of the exterior wall shall have the minimum *fire-resistance rating* required in Tables 601 and 602 for the exterior wall.

Reason:

The current code language provides continuity language for other fire-resistant rated wall assemblies, but not exterior walls. Therefore, there is confusion in the design and construction community on how to build the exterior walls. The proposal provides such language and clarifies the intent of the code for exterior walls. The language is similar to that of a fire partition.

Current Section 705.6 includes language regarding parapets that really doesn't belong in a structural requirement. Therefore, we have relocated language regarding parapets to the new Section for Continuity. It is better located there.

Cost Impact

The code change proposal will decrease the cost of construction .

The proposal will reduce the cost because the confusion will be eliminated and people will not be making things up.

Internal ID: 362

FS20-18

IBC: 202 (New), 705.6.1 (New), 707.5.2 (New)

Proponent: Paul Coats, American Wood Council, representing American Wood Council (pcoats@awc.org)

2018 International Building Code

SECTION 202 DEFINITIONS

Add new definition as follows:

PLATFORM CONSTRUCTION. A system of construction where the floor structure is supported by the bearing exterior and interior walls below, and supports the exterior walls and interior partitions above it.

SECTION 705 EXTERIOR WALLS

Add new text as follows:

705.6.1 Platform framing. Where floors connect to exterior walls in platform construction, the structural framing shall be protected at the intersection to maintain the continuity of the fire-resistance rating required of the wall, as required by Section 704.1. The fire-resistance rating shall be maintained through the use of materials permitted by the type of construction, but not limited to, one or more of the following: the ceiling membrane, solid blocking, solid wood elements, the rim board, protection by noncombustible materials, or other features or protection deemed to achieve the required fire-resistance rating. The requirements of Section 703.2.5 and 705.7 shall apply. The material requirements for the portion of the floor in the plane of the exterior wall shall be as for floor construction in accordance with the type of construction.

SECTION 707 FIRE BARRIERS

707.5.2 Platform framing. Where floors or roofs connect to fire barriers in platform construction, the structural framing shall be protected at the intersection to maintain the continuity of the required fire resistance rating for the fire barrier, and the support of the fire barrier in accordance with Section 704.1. The fire-resistance rating shall be maintained through the use of materials permitted by the type of construction, including but not limited to, one or more of the following: solid blocking, solid wood elements, the rim board, protection by noncombustible materials, or other features or protection deemed to achieve the required fire-resistance rating.

Reason:

This code change provides improved continuity of protection when exterior walls and fire barriers intersect with floors in buildings using platform construction.

Ratings required for exterior walls by either Table 602 or Table 601 may be greater than the rating required for the floors. As a result, questions arise about the protection of the wall/floor intersection in platform construction where differently rated elements come together. The protection of the intersection should be in accordance with the underlying principles of continuity and support for the rated wall construction. There are many practical solutions being used currently that would comply with this proposed code change. They involve the use of solid wood blocking or other protection to provide the continuity in fire resistance rating for the construction supporting the wall. AWC has developed details that may be approved by the code official for the exterior wall/floor intersection which can be found in the AWC Design for Code Acceptance (DCA) No. 3, Fire Rated Wood Wall and Floor Assemblies. They can be viewed and downloaded here: <http://awc.org/codes-standards/publications/dca3>. Link established 2.21.18.

The same questions arise for platform-framed fire barriers protecting shafts and interior stair enclosures, which often are required to be two-hour rated while the supporting floor construction is one-hour, therefore similar provisions were added to 707.5 for fire barriers.

Fire retardant treated wood (FRTW) is permitted for exterior walls of Type III and IV construction. Some code officials have required the floor construction in the plane of the exterior wall (the end of the floor in platform construction) to be FRTW, which is costly and burdensome and provides very little safety advantage since the intersection is already protected by FRTW or noncombustible cladding on the exterior. The proposal clarifies that for exterior wall intersections, the elements of the floor construction (joists, rim board, floor sheathing, and blocking if used) can be in accordance with the materials requirements for floors. The cladding component of the wall would need to be fire retardant treated or noncombustible as for the exterior wall framing itself.

Cost Impact

The code change proposal will not increase or decrease the cost of construction .

There are a variety of current interpretations and applications for fire resistance in platform construction involving exterior walls and fire barriers. This proposed change may slightly reduce or slightly increase construction costs, depending on the current approach of individual jurisdictions.

Internal ID: 437

FS21-18

IBC: 705.10 (New)

Proponent: Michael O'Brian, Chair, representing FCAC (fcac@iccsafe.org)

2018 International Building Code

Add new text as follows:

705.10 Penetrations. Penetrations of exterior walls required by this section to have a fire-resistance rating shall comply with Section 714.

Exception: Penetrations in exterior walls that are permitted to have unprotected openings.

Reason:

Protection of penetrations through fire-resistance-rated assemblies is a fundamental feature of compartmentation and the need to prevent fire and smoke spread. The IBC requires penetrations to be protected in fire walls (706.9), fire barriers (707.7), fire partitions (708.7), smoke barriers (709.6), smoke partitions (710.6), and vertical openings (712.1.4). The IBC distinguishes between openings and penetrations. In the context of IBC section 705.8, openings are not penetrations. So in the IBC, exterior wall penetrations (e.g. for pipes, ducts, and other services) do not require opening protectives. They are separate and distinct. Consequently, the IBC does not require protection of through-penetrations through exterior walls, even when they are fire-resistance-rated, and regardless of the limiting distance. Conversely, joints in exterior walls are already required to be protected in Section 705.9, and ducts & air transfer openings are required to be protected in Section 705.10.

The IBC does not currently limit the size, type, or number of unprotected penetrations in exterior walls. Tables 601 and 602 require exterior walls to have a fire-resistance rating under some circumstances. Further, Chapter 7 also requires fire rated opening protectives, rated joints, and ducts and transfer openings to be protected depending upon the limiting distance. This proposal would treat penetrations through rated exterior walls in the same manner as fire-resistant joints in exterior walls. It would require penetrations in exterior walls to be firestopped only when protected openings are required based on Chapter 6 and Chapter 7 limiting distance requirements.

This proposal is submitted by the ICC Fire Code Action Committee (FCAC). The FCAC was established by the ICC Board of Directors to pursue opportunities to improve and enhance assigned International Codes with regard to fire safety and hazardous materials in new and existing buildings and facilities and the protection of life and property in wildland urban interface areas. In 2017 the Fire-CAC has held 3 open meetings. In addition, there were numerous conference calls, Regional Work Group and Task Group meetings for the current code development cycle, which included members of the committees as well as any interested parties, to discuss and debate the proposed changes. Related documentation and reports are posted on the FCAC website at: <https://www.iccsafe.org/codes-tech-support/cs/fire-code-action-committee-fcac/>

Cost Impact

The code change proposal will increase the cost of construction .

Where unprotected openings are not permitted, penetrations which could previously be left unprotected will now require protection in accordance with Section 714.

Internal ID: 318

FS22-18

IBC: 706.1.1

Proponent: Jeffrey Shapiro, representing Self (jeff.shapiro@intlcodeconsultants.com)

2018 International Building Code

Revise as follows:

706.1.1 Party walls. Any wall located on a *lot line* between adjacent buildings, which is used or adapted for joint service between the two buildings, shall be constructed as a *fire wall* in accordance with Section 706. Party walls shall be constructed without openings and shall create separate buildings.

Exceptions:

1. Openings in a party wall separating an *anchor building* and a mall shall be in accordance with Section 402.4.2.2.1.
2. ~~Fire-Party walls and fire walls~~ are not required on lot lines dividing a building for ownership purposes where the aggregate height and area of the portions of the building located on both sides of the lot line do not exceed the maximum height and area requirements of this code. For the code official's review and approval, he or she shall be provided with copies of dedicated access easements and contractual agreements that permit the owners of portions of the building located on either side of the lot line access to the other side for purposes of maintaining fire and life safety systems necessary for the operation of the building.

Reason:

This section mixes use of the terms fire wall and party wall, and both should be mentioned in Exception 2 to make it clear that walls constructed in accordance with Exception 2 are allowed to have penetrations in accordance with the restrictions stated in the exception.

Cost Impact

The code change proposal will not increase or decrease the cost of construction .

Intended as a clarification of existing provisions.

Internal ID: 2389

FS23-18

IBC: 706.5, 706.5.1 (New), 706.5.2 (New), 706.5.1

Proponent: Ronald Clements Jr, representing Chesterfield County Building Inspection Department (clementsro@chesterfield.gov)

2018 International Building Code

Revise as follows:

706.5 Horizontal continuity. *Fire walls shall be continuous from exterior wall to exterior wall and shall terminate in accordance with this section extend not less than 18 inches (457 mm) beyond the exterior surface of exterior walls.*

Exceptions:

- ~~1. Fire walls shall be permitted to terminate at the interior surface of combustible exterior sheathing or siding provided that the exterior wall has a fire-resistance rating of not less than 1 hour for a horizontal distance of not less than 4 feet (1220 mm) on both sides of the fire wall. Openings within such exterior walls shall be protected by opening protectives having a fire protection rating of not less than $\frac{3}{4}$ hour.~~
- ~~2. Fire walls shall be permitted to terminate at the interior surface of noncombustible exterior sheathing, exterior siding or other noncombustible exterior finishes provided that the sheathing, siding or other exterior noncombustible finish extends a horizontal distance of not less than 4 feet (1220 mm) on both sides of the fire wall.~~
- ~~3. Fire walls shall be permitted to terminate at the interior surface of noncombustible exterior sheathing where the building on each side of the fire wall is protected by an automatic sprinkler system installed in accordance with Section 903.3.1.1 or 903.3.1.2.~~

Add new text as follows:

706.5.1 Termination at 180 degree or greater exterior wall angle. Where the angle between the exterior walls on either side of the fire wall is equal to or greater than 180 degrees (3.14 rad), the fire wall termination shall comply with one of the following:

1. The fire wall shall terminate at the interior surface of any exterior sheathing or siding permitted by this code provided that the exterior wall has a fire-resistance rating of not less than 1 hour for a horizontal distance of not less than 4 feet (1220 mm) on both sides of the fire wall. Openings within such exterior walls within 4 feet (1220 mm) of the fire wall shall be protected by opening protectives having a fire protection rating of not less than $\frac{3}{4}$ hour.
2. The fire wall shall terminate at the interior surface of noncombustible exterior sheathing with non-combustible exterior siding or other noncombustible exterior finishes provided that the non-combustible sheathing and siding or other exterior noncombustible finish extends a horizontal distance of not less than 4 feet (1220 mm) on both sides of the fire wall. Openings within such exterior walls within 4 feet (1220 mm) of the fire wall shall be protected by opening protectives having a fire protection rating of not less than $\frac{3}{4}$ hour.
3. The fire wall shall terminate at the interior surface of noncombustible exterior sheathing with any siding or exterior finish materials permitted by this code provided that the non-combustible sheathing extends a horizontal distance of not less than 4 feet (1220 mm) on both sides of the fire wall and the buildings on each side of the fire wall are protected by an automatic sprinkler system installed in accordance with Section 903.3.1.1 or 903.3.1.2. Openings within such exterior walls within 4 feet (1220 mm) of the fire wall shall be protected by opening protectives having a fire protection rating of not less than $\frac{3}{4}$ hour.
4. The fire wall shall terminate at the interior surface of masonry or concrete exterior walls where the masonry or concrete exterior walls extend a horizontal distance of not less than 4 feet (1220 mm) on both sides of the fire wall. Openings within such exterior walls within 4 feet (1220 mm) of the fire wall shall be protected by opening protectives having a fire protection rating of not less than $\frac{3}{4}$ hour.
5. The fire wall shall terminate at the interior surface of any exterior sheathing or siding permitted by this code provided the buildings on each side of the fire wall are protected by an automatic sprinkler system installed in accordance with Section 903.3.1.1.

6. The fire wall shall extend not less than 18 inches (457 mm) beyond the exterior surface of the exterior wall.

706.5.2 Termination at less than 180 degree exterior wall angle. Where the angle between the exterior walls on either side of the fire wall, within 4 feet (1220 mm) of the fire wall, is less than 180 degrees (3.14 rad), the fire wall termination shall extend to the plane of the exterior sheathing or surface of one of the exterior walls on either side of the fire wall. An imaginary line shall be established extending out from the fire wall termination point between the exterior walls on both sides of the fire wall for the purpose of establishing the fire separation distance for the exterior walls. The fire-resistance rating and opening protection requirements for the exterior walls shall meet Sections 705.5 and 705.8 based on the fire separation distance established by the imaginary line.

Delete without substitution:

~~**706.5.1 Exterior walls.** Where the fire wall intersects exterior walls, the fire-resistance rating and opening protection of the exterior walls shall comply with one of the following:~~

- ~~1. The exterior walls on both sides of the fire wall shall have a 1-hour fire-resistance rating with $3/4$ -hour protection where opening protection is required by Section 705.8. The fire-resistance rating of the exterior wall shall extend not less than 4 feet (1220 mm) on each side of the intersection of the fire wall to exterior wall. Exterior wall intersections at fire walls that form an angle equal to or greater than 180 degrees (3.14 rad) do not need exterior wall protection.~~
- ~~2. Buildings or spaces on both sides of the intersecting fire wall shall assume to have an imaginary lot line at the fire wall and extending beyond the exterior of the fire wall. The location of the assumed line in relation to the exterior walls and the fire wall shall be such that the exterior wall and opening protection meet the requirements set forth in Sections 705.5 and 705.8. Such protection is not required for exterior walls terminating at fire walls that form an angle equal to or greater than 180 degrees (3.14 rad).~~

Reason:

The fire wall horizontal termination provisions are set up with section 706.5 providing the termination methods for firewall terminations where the exterior walls on either side are at an angle of 180 degrees or greater and section 706.5.1 providing the termination methods for fire wall termination where the exterior walls on either side are at an angle less than 180. 706.5.1 is an additional requirement, when the angle is less than 180, to the base requirement in 706.5. This does not work in practice. If a fire wall terminates at the vertex of a 90 degree angle between the two exterior walls on either side the fire wall cannot extend 18 inches beyond the surface of the exterior wall nor can the fire wall extend to the surface of the exterior sheathing so the sections cannot build on one another. Section 706.5.1 refers to conditions when a fire wall intersects the exterior wall. Geometrically an intersection is a point common to two lines so the condition detailed in 706.5 for a 180 termination is an intersection of the exterior wall by the fire wall so one could argue that the last sentence of 706.5.1 items 1 and 2 override the requirements of 706.5 when the exterior walls are at 180 to each other. That is not the intent. This code change fixes the problem by separating out the termination requirements based on the angle between the exterior walls. The 706.5.1 method applies when the angle between exterior walls is 180 degrees or greater and the 706.5.2 method applies when the angle between exterior walls is less than 180 degrees.

Additionally the base requirement for the 18" extension is the exception, not the rule, so the exceptions have been re-organized into options and the 18 inch exception is now another option. The termination methods that allow termination at sheathing have opening protection requirements added since the code is currently silent on this fact. Current code would allow the entire 4 foot to be open. New option 4 was added to allow termination of the fire wall at an exterior masonry or concrete wall, this is currently not addressed. New option 5 was added to allow for a full NFPA 13 sprinkler to count as equivalent to 4 feet on non-combustible siding.

Section 706.5.2 addresses the firewall termination where the exterior walls on either side are at an angle less than 180 degrees. The first exception was removed because it makes no sense to allow this method when it would not be allowed if the buildings were separated by an inch. If two adjacent buildings are separated and joined by a fire wall and they have exterior walls that are exposed to each other at angles less than 180 degrees they should be treated as separate buildings for exposure purposes just as any two separate buildings would be treated. Current exception 1 gives you a less restrictive method when the building are touching; that makes no sense. The imaginary line exception is now a single requirement. The section was also cleaned up so it is clear how to apply the imaginary line. The current text literally states that the wall itself will assume to have an imaginary line. Walls cannot assume things. The current text also does not clearly state that the imaginary line is to be used to establish fire separation distances. Since that is not provided based on current text there is no protection requirement because section 705.5 and 705.8 are based on fire separation distance defined in chapter 2.

Example of less than 180 termination

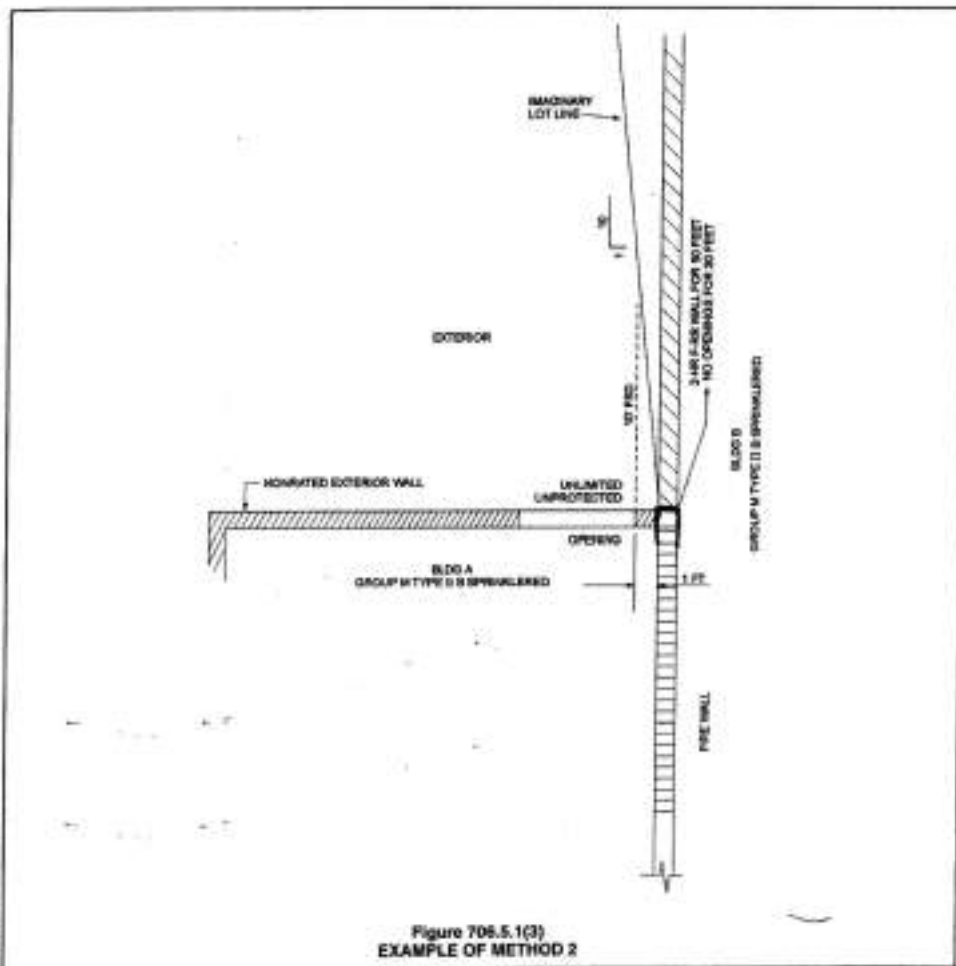

Cost Impact

The code change proposal will not increase or decrease the cost of construction .

This is a clarifying code change.

Internal ID: 845

FS24-18

IBC: 706.6.1

Proponent: Lee Kranz, representing Washington Association of Building Officials Technical Code Development Committee (lkranz@bellevuewa.gov)

2018 International Building Code

Revise as follows:

706.6.1 Stepped buildings. Where a *fire wall* also serves as an *exterior wall* for a building and separates buildings having different roof levels, such wall shall terminate at a point not less than 30 inches (762 mm) above the lower roof level, ~~provided the exterior wall for a height of 15 feet (4572 mm) level.~~ Exterior walls above the fire wall extending more than 30 inches (762 mm) above the lower roof shall be of not less than 1-hour fire-resistance-rated construction from both sides with openings protected by fire assemblies having a *fire protection rating* of not less than $\frac{3}{4}$ hour. Portions of the exterior walls greater than 15 feet (4572 mm) above the lower roof shall be of non-fire-resistance rated construction unless otherwise rated construction is required by other provisions of this code.

Exception: ~~Where the A fire wall terminates serving as part of an exterior wall for a building that separates buildings having different roof levels shall be permitted to terminate at the underside of the roof sheathing, deck or slab of the lower roof, provided that all of the following requirements are met:~~

1. The lower roof assembly within 10 feet (3048 mm) of the fire wall has not less than a 1-hour *fire-resistance rating*, and the
2. The entire length and span of supporting elements for the rated roof assembly ~~has~~ shall have a fire-resistance rating of not less than 1-hour.
- ~~2-3.~~ Openings in the lower roof shall not be located within 10 feet (3048 mm) of the *fire wall*.
4. 1-hour fire- resistance rated exterior wall protection above the lower roof, as specified in this section, is not required unless fire resistance rated construction is required by other provisions of this

Reason:

Section 706.6.1 is confusing as currently written. It is intended to regulate the design of fire walls and exterior walls above and in-line with the fire walls for buildings having stepped roof levels. The intent of this section is to maintain adequate separation between the two portions of the same building so that one side will not be damaged for the time required by Section 706.4. This is done by extending the fire wall to at least 30" above the lower roof and rating the exterior wall above and in-line to not less than 1-hour up to 15' above the lower roof. The second option is to provide a 1-hour rated roof assembly extending not less than 10' over from the fire wall with no openings permitted within the 10' portion of the roof adjacent to the fire wall.

This proposal does not change the requirements of the section. Rather, the text has been re-written to clarify the expectations for the exterior wall located above the lower roof and sets clear expectations in the exception for horizontal protection by itemizing these requirements.

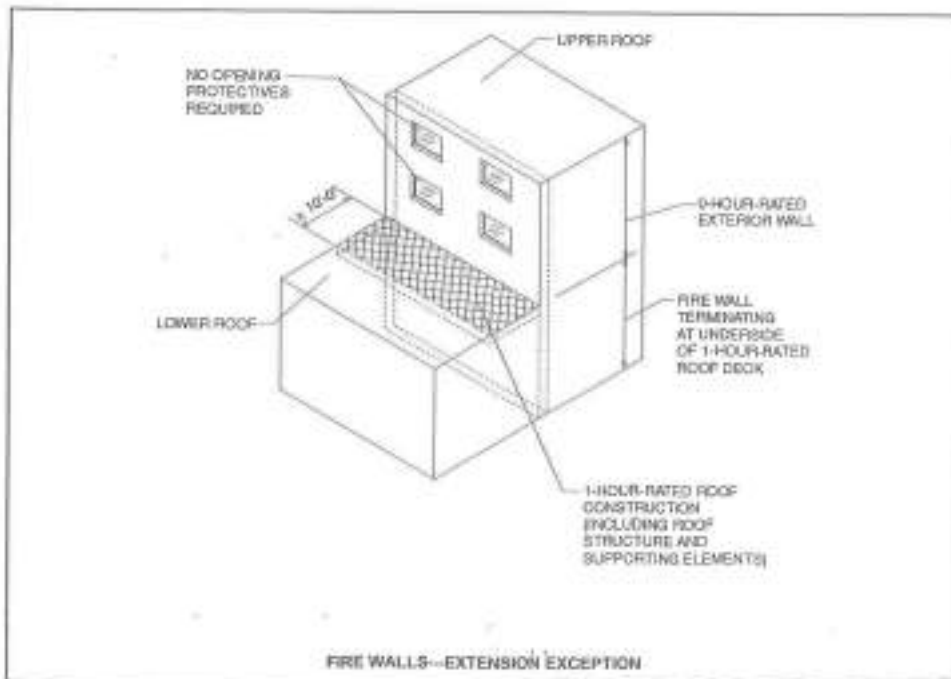
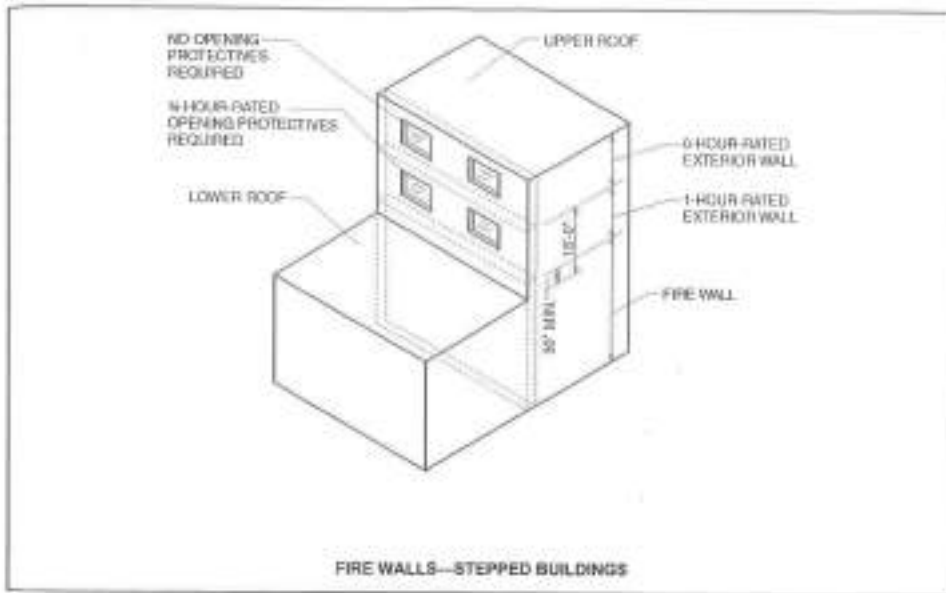

Cost Impact

The code change proposal will not increase or decrease the cost of construction .

This code change is being made in an attempt to clarify the code. It will not change the cost of construction of fire walls.

Internal ID: 88

FS25-18

IBC: 706.8 (New), 704.11

Proponent: Jonathan Siu, City of Seattle Department of Construction and Inspections, representing Washington Association of Building Officials Technical Code Development Committee (Jon.Siu@seattle.gov)

2018 International Building Code

Add new text as follows:

706.8 Supporting construction. The supporting construction for a fire wall shall be protected to afford the required fire resistance rating of the fire wall supported. Hollow vertical spaces within a fire wall shall be fireblocked in accordance with Section 718.2 at every floor level.

Revise as follows:

704.11 Bottom flange protection. Fire protection is not required at the bottom flange of lintels, shelf angles and plates, spanning not more than 6 feet 4 inches (1931 mm) whether part of the primary structural frame or not, and from the bottom flange of lintels, shelf angles and plates not part of the structural frame, regardless of span. Fire protection shall be provided at the bottom flange of lintels, shelf angles and plates, spanning more than 6 feet 4 inches, where they support fire wall or fire barrier construction.

Reason:

This proposal is intended to clarify the requirements for structural members, including lintels and similar members, supporting fire walls.

New Section 706.8 regarding supporting construction for fire walls:

As currently written, the code does not specify what level of fire resistance rating is required for structural members supporting fire walls. There are requirements for supporting construction for fire barriers and horizontal assemblies in Sections 707.5.1 and 711.2.3, but none for fire walls. This leaves the code requirement open to interpretation--is supporting construction part of the fire wall and protected accordingly, or is it part of the structural frame, or can it be unprotected because the code doesn't specifically require protection?

The last two interpretations can result in unprotected construction supporting a fire wall above. Particularly regarding primary or secondary structural frame, a beam supporting a fire wall above an opening may not be "structural frame" if the fire wall is not a bearing wall. This seems to be inconsistent with the requirements for structural stability of the fire wall in Section 706.2, as well as the requirements to protect supporting construction for fire barriers and horizontal assemblies. Note that the lack of the requirement in fire walls versus the specific requirement in fire barriers and horizontal assemblies is used as an argument that the code writers deliberately omitted the requirement for fire walls.

The assumption may be that a fire wall is continuous from foundation to roof, but the code allows large openings up to 156 square feet in fire walls (Section 706.8). A beam supporting fire wall construction above a 12-foot high opening could have an unprotected 13-foot span. Some jurisdictions may be able to get protection for that beam by calling it part of the fire wall, but that is arguable.

This proposed code change addresses the issue by inserting a new section into Section 706 to clarify construction must have the same fire resistance rating as the fire wall it structurally supports. The proposed text is identical to the language currently used for fire barriers in Section 707.5.1, including the requirement for fireblocking at floors. We evaluated the exceptions in Sections 707.5.1 and 711.2.3 (parallel requirement for horizontal assemblies), and determined that none were applicable to fire walls, as they relate to providing separations between occupancies or incidental uses, or to other wall types.

Section 704.11 regarding lintels, shelf angles, and plates:

While the online Merriam-Webster dictionary broadly defines a lintel as "a horizontal architectural member spanning and usually carrying the load above an opening," our experience is the terms "lintels, shelf angles, or plates" as used in this section are generally intended to be used in the context of supporting concrete or masonry materials above.

As written, this section requires protection for the bottom flange of these members if they span more than 6'-4" and are part of the primary or secondary structural frame. However, if a concrete or masonry fire wall or fire barrier is not also a bearing wall, it is questionable whether this section applies, since these members can be interpreted as being neither primary nor secondary structural frame. This then leaves it open to interpretation whether fire protection is required for a lintel supporting concrete or masonry in a non-bearing fire wall or fire barrier.

This proposal clarifies lintels, shelf angles, or plates spanning more than 6'-4" must be protected if they support fire wall or fire barrier construction.

Related code change proposal:

A separate but related code change proposal has been submitted to clarify requirements for supporting bearing walls. If this proposal and the bearing wall proposal both pass, the combined Section 704.11 can appear as follows:

704.11 Lintels, shelf angles, and plates. Fire protection shall be provided at the bottom flange of lintels, shelf angles and plates, where they span more than 6 feet 4 inches (1931 mm) and meet at least one of the following conditions:

1. They are an element of the structural frame, or
2. They support fire wall or fire barrier construction.

Cost Impact

The code change proposal will increase the cost of construction .

Because this is a clarification of the current code language, the impact on cost of construction will depend on how a local jurisdiction is interpreting the current code provisions. If the jurisdiction is requiring fire resistance ratings consistent with the fire resistance rating of fire walls, there will be no change in the cost of construction. However, if the jurisdiction is applying the code literally, this proposal could result in increased cost for fireproofing of beams or some lintels providing structural support for non-bearing fire walls or fire barriers.

Internal ID: 630

FS26-18

IBC: 707.4, TABLE 716.1(2), TABLE 716.1(3), 716.2.5.4.1 (New), 716.3.2.1.1.1 (New)

Proponent: Robert Davidson, Davidson Code Concepts, LLC, representing Tesla USA/Safti First (rjd@davidsoncodeconcepts.com)

2018 International Building Code

Revise as follows:

707.4 Exterior walls. Where exterior walls serve as a part of a required fire-resistance-rated shaft or stairway or ramp enclosure, or separation, such walls shall comply with the requirements of Section 705 for exterior walls and the fire-resistance-rated enclosure or separation requirements shall not apply.

~~Exception~~**Exceptions:**

1. Exterior walls required to be *fire-resistance rated* in accordance with Section 1021 for exterior egress balconies, Section 1023.7 for interior exit stairways and ramps and Section 1027.6 for exterior exit stairways and ramp.
2. Exterior walls required to be *fire-resistance rated* in accordance with Section 1206 of the International Fire Code for enclosure of energy storage systems.

TABLE 716.1(2)

OPENING FIRE PROTECTION ASSEMBLIES, RATINGS AND MARKINGS

TYPE OF ASSEMBLY	REQUIRED WALL ASSEMBLY RATING (hours)	MINIMUM FIRE DOOR AND FIRE SHUTTER ASSEMBLY RATING (hours)	DOOR VISION PANEL SIZE ^b	FIRE-RATED GLAZING MARKING DOOR VISION PANEL ^{c, e}	MINIMUM SIDELIGHT/TRANSOM ASSEMBLY RATING (hours)		FIRE-RATED GLAZING MARKING SIDELIGHT/TRANSOM PANEL	
					Fire protection	Fire resistance	Fire protection	Fire resistance
Fire walls and fire barriers having a required fire-resistance rating greater than 1 hour	4	3	See Note b	D-H-W-240	Not Permitted	4	Not Permitted	W-240
	3	3a	See Note b	D-H-W-180	Not Permitted	3	Not Permitted	W-180
	2	1½	100 sq. in.	≤ 100 sq. in. = D-H-90 > 100 sq. in. = D-H-W-90	Not Permitted	2	Not Permitted	W-120
	1½	1½	100 sq. in.	≤ 100 sq. in. = D-H-90 > 100 sq. in. = D-H-W-90	Not Permitted	1½	Not Permitted	W-90
Enclosures for shafts, interior exit stairways and interior exit ramps.	2	1½	100 sq. in. ^c	≤ 100 sq. in. = D-H-90 > 100 sq. in. = D-H-T-W-90	Not Permitted	2	Not Permitted	W-120
Horizontal exits in fire walls ^d	4	3	100 sq. in.	≤ 100 sq. in. = D-H-180 > 100 sq. in. = D-H-W-240	Not Permitted	4	Not Permitted	W-240
	3	3 ^e	100 sq. in.	≤ 100 sq. in. = D-H-180 > 100 sq. in. = D-H-W-180	Not Permitted	3	Not Permitted	W-180
Fire barriers having a required fire-resistance rating of 1 hour; Enclosures for shafts, exit access stairways, exit access ramps, interior exit stairways and interior exit ramps; and exit passageway walls	1	1	100 sq. in.	≤ 100 sq. in. = D-H-60 > 100 sq. in. = D-H-T-W-60	Not Permitted	1	Not Permitted	W-60
					Fire protection			
Other fire barriers	1	¾	Maximum size tested	D-H	¾ ^f		D-H ^f	
Fire partitions: Corridor walls	1 0.5	1/5b 1/5b	Maximum size tested Maximum size tested	D-20 D-20	¾b 1/5		D-H-OH-45 D-H-OH-20	
Other fire partitions	1 0.5	¾ 1/3	Maximum size tested Maximum size tested	D-H-45 D-H-20	¾ 1/3		D-H-45 D-H-20	
Exterior walls	3	1½	100 sq. in. ^b	≤ 100 sq. in. = D-H-90 > 100 sq. in. = D-H-W-90	Not Permitted	3	Not Permitted	W-180
	2	1½	Maximum size tested	D-H 90 or D-H-W-90	1 1/2 ^f	2	D-H-OH-90 ^f	W-120
						Fire protection		
	1	¾	Maximum size tested	D-H-45	¾ ^f		D-H-45 ^f	
					Fire protection			
Smoke barriers	1	1/3	Maximum size tested	D-20	¾		D-H-OH-45	

For SI: 1 square inch = 645.2 mm.

- a. Two doors, each with a fire protection rating of 1¹/₂ hours, installed on opposite sides of the same opening in a fire wall, shall be deemed equivalent in fire protection rating to one 3-hour fire door.
- b. Fire-resistance-rated glazing tested to ASTM E119 in accordance with Section 716.1.2.3 shall be permitted, in the maximum size tested.
- c. Under the column heading "Fire-rated glazing marking door vision panel," W refers to the fire-resistance rating of the glazing, not the frame.
- d. See Section 716.2.5.1.2.1.
- e. See Section 716.1.2.2.1 and Table 716.1(1) for additional permitted markings.
- f. Fire-protection-rated glazing is not permitted for fire barriers required by Section 1206 of the International Fire Code to enclose energy storage systems. Fire-resistance-rated glazing assemblies tested to ASTM E119 or UL 263, as specified in Section 716.1.2.3 shall be permitted.

**TABLE 716.1(3)
FIRE WINDOW ASSEMBLY FIRE PROTECTION RATINGS**

TYPE OF WALL ASSEMBLY	REQUIRED WALL ASSEMBLY RATING (hours)	MINIMUM FIRE WINDOW ASSEMBLY RATING (hours)	FIRE-RATED GLAZING MARKING
Interior walls			
Fire walls	All	NP ^a	W-XXX ^b
Fire barriers	>1	NP ^a	W-XXX ^b
	1	NP ^a	W-XXX ^b
Atrium separations (Section 707.3.6), Incidental use areas (Section 707.3.7) ^c , Mixed occupancy separations (Section 707.3.9)	1	³ / ₄	OH-45 or W-60
Fire partitions	1	³ / ₄	OH-45 or W-60
	0.5	¹ / ₃	OH-20 or W-30
Smoke barriers	1	³ / ₄	OH-45 or W-60
Exterior walls	>1	1 ¹ / ₂	OH-90 or W-XXX ^b
	1	³ / ₄	OH-45 or W-60
	0.5	¹ / ₃	OH-20 or W-30
Party wall	All	NP	Not Applicable

NP = Not Permitted.

- a. Not permitted except fire-resistance-rated glazing assemblies tested to ASTM E119 or UL 263, as specified in Section 716.1.2.3.
- b. XXX = The fire rating duration period in minutes, which shall be equal to the fire-resistance rating required for the wall assembly.
- c. Fire-protection-rated glazing is not permitted for fire barriers required by Section 1206 of the International Fire Code to enclose energy storage systems. Fire-resistance-rated glazing assemblies tested to ASTM E119 or UL 263, as specified in Section 716.1.2.3 shall be permitted.

716.2.5.4 Fire door frames with transom lights and sidelights. Fire-protection-rated glazing shall be permitted in door frames with transom lights, sidelights or both, where a 3/4-hour *fire protection rating* or less is required and in 2-hour fire-resistance-rated exterior walls in accordance with Table 716.1(2). *Fire door* frames with transom lights, sidelights, or both, installed with fire-resistance-rated glazing tested as an assembly in accordance with ASTM E119 or UL 263 shall be permitted where a *fire protection rating* exceeding 3/4 hour is required in accordance with Table 716.1(2).

Add new text as follows:

716.2.5.4.1 Energy storage system separation. Fire-protection-rated glazing shall not be permitted in fire door frames with transom lights and sidelights in fire barriers required by Section 1206 of the International Fire Code to enclose energy storage systems.

716.3.2.1 Interior fire window assemblies. Fire-protection-rated glazing used in fire window assemblies located in fire partitions and fire barriers shall be limited to use in assemblies with a maximum fire-resistance rating of 1 hour in accordance with this section.

716.3.2.1.1 Where 3/4-hour-fire-protection window assemblies permitted. Fire-protection-rated glazing requiring 45-minute opening protection in accordance with Table 716.1(3) shall be limited to fire partitions designed in accordance with Section 708 and fire barriers utilized in the applications set forth in Sections 707.3.6, 707.3.7 and 707.3.9 where the fire-resistance rating does not exceed 1 hour. Fire-resistance-rated glazing assemblies tested in accordance with ASTM E119 or UL 263 shall not be subject to the limitations of this section.

716.3.2.1.1.1 Energy storage system separation. Fire-protection-rated glazing is not permitted for use in fire window assemblies in fire barriers required by Section 1206 of the International Fire Code to enclose energy storage systems.

Reason:

Battery storage systems, now referred to as Energy Storage Systems, have historically been separated from other portions of an occupancy by one or two hour fire-resistance-rated construction as an Incidental Use. The enclosure protects the general occupancy areas from an event involving the Incidental Use.

One of the hazards of an energy storage system is thermal runaway leading to a fire event. These fire events can be significant and last several hours. The systems are required to be designed to prevent thermal runaway internally, however, thermal runaway can be induced in some case by an exterior event such as a damaging impact or from a fire exposure. Though the code now requires fire suppression of the space occupied by the energy storage system, the remainder of the occupancy may not be protected and the current code language allows the use of fire-protection-rated glazing material in door and window openings.

Fire-protection-rated glazing is intended to stop spread of flame and smoke, but not radiant heat. The radiant heat flow through the glazing is significant, enough to cause a fire on the other side of the fire-resistance-rated separation assembly, and, specific to this issue, induce thermal runaway of the energy storage system. (See the included Intertek test report and heat transmittal through ceramic fire-protection-rated glazing with a revision date of May 13, 2016.)

https://www.dropbox.com/sh/n8h65nht5dcruq5/AAAZxIS4ioKu_eTXz1GqjwQ3a?dl=0

A large part of the new requirements in the International Fire Code targeting energy storage systems and in the currently in cycle NFPA 855 Energy Storage Systems Standard is protecting the energy storage system from exposure hazards to the system. This proposal builds on that part of the protection to the systems by prohibiting the use of fire-protection-rated glazing in one hour assemblies that are used to enclose energy storage systems.

Cost Impact

The code change proposal will increase the cost of construction .

The increase in cost of construction is specific to energy storage system and is negligible compared to the overall cost of compliance when installing energy storage systems.

Internal ID: 1872

FS27-18

IBC: 707.5

Proponent: David Renn, City and County of Denver, representing Code Change Committee of Colorado Chapter of the ICC (david.renn@denvergov.org)

2018 International Building Code

Revise as follows:

707.5 Continuity. *Fire barriers* shall extend from the top of the foundation or floor/ceiling assembly below to the underside of the floor or roof sheathing, slab or deck above and shall be securely attached thereto. Such *fire barriers* shall be continuous through concealed space, such as the space above a suspended ceiling. Joints and voids at intersections shall comply with Sections 707.8 and 707.9

Exceptions:

1. Shaft enclosures shall be permitted to terminate at a top enclosure complying with Section 713.12.
2. *Interior exit stairway* and *ramp* enclosures required by Section 1023 and *exit access stairway* and *ramp* enclosures required by Section 1019 shall be permitted to terminate at a top enclosure complying with Section 713.12.
3. An exit passageway enclosure required by Section 1024.3 that does not extend to the underside of the roof sheathing, slab or deck above shall be enclosed at the top with construction of the same fire-resistance rating as required for the exit passageway.

Reason:

Exception 2 currently allows interior exit stairway and ramp enclosures to terminate at a top enclosure meeting the requirements for a top enclosure of a shaft. This proposed change extends this same allowance to exit passageways. Since exit passageways and interior exit stairways and ramps are all exit components, the current allowance for a top enclosure should apply to all of these components. Since an exit passageway does not penetrate a floor as shaft does, this proposal includes this allowance as a new exception, rather than referring to top enclosure requirements for shafts.

The use of a fire-resistance rated top enclosure for an exit passageway is commonly used as a means to allow mechanical, electrical and plumbing work to route above an exit enclosure. This proposal would specifically allow what is currently allowed by many jurisdictions through the modifications provisions in IBC 104.10.

Cost Impact

The code change proposal will not increase or decrease the cost of construction .

There is no change to construction cost since this new exception is not required to be used. If used, there is a cost trade off between extending fire barriers to the roof, sheathing, slab or deck and providing the top enclosure. Savings in mechanical, electrical or plumbing systems may be realized by routing over an exit passageway instead of around an exit passageway.

Internal ID: 1226

FS28-18

IBC: 707.5.1

Proponent: Homer Maiel, representing ICC Tri-Chapter (Peninsula, East Bay, Monterey Bay) (hmaiel@gmail.com)

2018 International Building Code

Revise as follows:

707.5.1 Supporting construction. The supporting construction for a *fire barrier* shall be protected to afford the required *fire-resistance rating* of the *fire barrier* supported. Hollow vertical spaces within a *fire barrier* shall be fireblocked in accordance with Section 718.2 at every floor level.

Exceptions:

1. The maximum required *fire-resistance rating* for assemblies supporting *fire barriers* separating tank storage as provided for in Section 415.9.1.2 shall be 2 hours, but not less than required by Table 601 for the building construction type.
2. Supporting construction for 1-hour *fire barriers* required by Table 509 in buildings of Types IIB, IIIB and VB construction is not required to be *fire-resistance rated* unless required by other sections of this code.
3. Supporting construction for 2-hour interior exit stairways and ramps shaft enclosure of Section 1023.2, is not required to exceed the ratings given in Table 601 unless required by other sections of this code.

Reason:

One hour buildings and 2-hour shafts. Shaft walls are officially fire barriers. Therefore, some jurisdictions require that elevator and stairs shafts in Type IIA, IIIA and VA four story buildings need to have their shafts supported by a structural system that complies with 2-hour fire resistance. This is questionable logic. This means that the code allows the building to completely fall down after a 1 hour fire but the code wants the shaft to remain standing among the rubble? I have always thought of this as odd, and not very practical to design or construct, and not very defensible from a logical point of view.

Cost Impact

The code change proposal will decrease the cost of construction .

This code change will decrease the cost of construction.

If this proposal is approved, the required fire rating of the supporting structure could be reduced and as the result cost of construction can be decreased.

Internal ID: 1524

FS29-18

IBC: 707.8, 707.9

Proponent: Michael O'Brian, Chair, representing FCAC (fcac@iccsafe.org)

2018 International Building Code

Revise as follows:

~~**707.8 Joints, joints and voids.** Joints made in or between fire barriers, and joints made at the intersection of fire barriers with underside of a fire resistance rated floor or roof sheathing, slab or deck above, and the exterior vertical wall intersection shall comply with Section 715~~

The following joints and voids shall be protected in accordance with Section 715.

1. Joints in or between fire barriers.
2. Joints between fire barriers and fire-resistance-rated wall assemblies.
3. Joints between fire barriers and the underside of fire-resistance-rated floors or floor/ceiling assemblies
4. Joints between fire barriers and the underside of fire-resistance rated roofs or roof/ceiling assemblies.
5. Voids at the intersection of fire barriers and nonfire-resistance-rated exterior curtain wall assemblies.
6. Voids between fire barriers and the underside of nonfire-resistance-rated roofs or roof/ceiling assemblies.
7. Voids between fire barriers and the underside of nonfire-resistance-rated floors or floor/ceiling assemblies.

Delete without substitution:

~~**707.9 Voids at intersections.** The voids created at the intersection of a *fire barrier* and a nonfire resistance rated roof assembly or a nonfire resistance rated exterior wall assembly shall be filled. An approved material or system shall be used to fill the void, and shall be securely installed in or on the intersection for its entire length so as not to dislodge, loosen or otherwise impair its ability to accommodate expected building movements and to retard the passage of fire and hot gases.~~

Reason:

Other FCAC proposals reorganize and make changes to Section 715, including adding protection requirements for voids, so Section 707.9 is no longer needed. This proposal simplifies the references to Section 715 and includes all of the joints and voids that require protection. Depending on the action on the other proposals Item (7) may need to be deleted from this proposal.

This proposal is submitted by the ICC Fire Code Action Committee (FCAC). The FCAC was established by the ICC Board of Directors to pursue opportunities to improve and enhance assigned International Codes with regard to fire safety and hazardous materials in new and existing buildings and facilities and the protection of life and property in wildland urban interface areas. In 2017 the Fire-CAC has held 3 open meetings. In addition, there were numerous conference calls, Regional Work Group and Task Group meetings for the current code development cycle, which included members of the committees as well as any interested parties, to discuss and debate the proposed changes. Related documentation and reports are posted on the FCAC website at: <https://www.iccsafe.org/codes-tech-support/cs/fire-code-action-committee-fcac/>

Cost Impact

The code change proposal will not increase or decrease the cost of construction .

The changes are editorial and do not add new construction requirements.

Internal ID: 300

FS30-18

IBC: 202 (New), 202, 707.9, 715.5 (New), Chapter 35

Proponent: Michael O'Brian, Chair, representing FCAC (fcac@iccsafe.org)

2018 International Building Code

SECTION 202 DEFINITIONS

Add new definition as follows:

CONTINUITY HEAD-OF-WALL JOINT SYSTEM An assemblage of specific materials or products that are designed to resist the passage of fire through voids created at the intersection of fire barriers and the underside of nonfire-resistance-rated roofs and floors for a prescribed period of time.

Revise as follows:

[BF] F RATING. The time period that the through-penetration firestop system or continuity head-of-wall joint system limits the spread of fire through the penetration when tested in accordance with ASTM E814 or UL 1479 or void.

[BF] T RATING. The time period that the penetration firestop system, including the penetrating item, or the continuity head-of-wall joint system limits the maximum temperature rise to 325°F (163°C/180°C) above its initial temperature through the penetration or void on the nonfire side when tested in accordance with ASTM E814 or UL 1479 side.

707.9 Voids at intersections. The voids created at the intersection of a *fire barrier* and a nonfire-resistance-rated roof or floor assembly or a nonfire-resistance-rated exterior wall assembly shall be filled. An approved material or system shall be used to fill the void, and shall be securely installed in or on the intersection for its entire length so as not to dislodge, loosen or otherwise impair its ability to accommodate expected building movements and to retard the passage of fire and hot gases protected with a material or system which complies with Section 715.

Add new text as follows:

715.5 Voids at intersection of fire barriers and underside of nonfire-resistance-rated roofs and floors. The voids created at the intersection of a fire barrier and the underside of a nonfire-resistance-rated roof or floor sheathing, slab or deck above shall be protected by an approved continuity head-of-wall joint system installed as tested in accordance with ASTM E2837 to provide an F rating/T rating for a time period not less than the required fire-resistance rating of the wall assembly in which it is installed or with an approved material or system. Such materials or systems shall be securely installed in accordance with the manufacturer's installation instructions in or on the void for its entire length so as not to dislodge, loosen or otherwise impair its ability to accommodate expected building movements and to resist the passage of fire and hot gases. Continuity head-of-wall joint systems shall also be installed in accordance with the listing criteria.

Add new standard(s) follows:

ASTM

ASTM International
100 Barr Harbor Drive, P.O. Box
C700
West Conshohocken PA 19428-
2959
US

E2837-17:

Standard Test Method for Determining the Fire Resistance of Continuity Head-of-Wall Joint Systems Installed Between Rated Wall Assemblies and Nonrated Horizontal Assemblies

Reason:

Section 707.9 of the 2012 and later editions of the International Building Code have a provision whereby the voids created at the intersection of a fire barrier and the underside of a nonfire-resistance-rated roof sheathing, slab or deck above shall be filled with an approved material or system. This proposal is intended to introduce similar requirements for the void created at the intersection of a fire barrier and the underside of a nonfire-resistance-rated floor sheathing, slab or deck. The language proposed gives an option to fill the void with an approved material, or to protect it with a continuity head-of-wall joint system tested to a new Standard ASTM E2837, entitled "Standard Test

Method for Determining the Fire Resistance of Continuity Head-of-Wall Joint Systems Installed Between Rated Wall Assemblies and Nonrated Horizontal Assemblies". Since there are a limited number of published systems at this time, the use of a tested system is being proposed as an option to the allowance of an approved material or system. At some later date, when more tested systems are available, the code language can be revised once again to mandate tested systems in much the same way systems tested to ASTM E1966 or UL 2079 are mandated for rated-to-rated construction.

This proposal also parallels another proposal which introduces the new ASTM standard for use with the void at the intersection of a fire barrier and a nonfire-resistance-rated roof assembly. This proposal incorporates the required changes relating to both the roof and the floor intersections. If both proposals are approved as submitted, the language of this proposal prevails as it incorporates the required changes for voids beneath both roofs and floors.

The proposal also compliments a proposal which reorganizes Section 715.

This proposal is submitted by the ICC Fire Code Action Committee (FCAC). The FCAC was established by the ICC Board of Directors to pursue opportunities to improve and enhance assigned International Codes with regard to fire safety and hazardous materials in new and existing buildings and facilities and the protection of life and property in wildland urban interface areas. In 2017 the Fire-CAC has held 3 open meetings. In addition, there were numerous conference calls, Regional Work Group and Task Group meetings for the current code development cycle, which included members of the committees as well as any interested parties, to discuss and debate the proposed changes. Related documentation and reports are posted on the FCAC website at: <https://www.iccsafe.org/codes-tech-support/cs/fire-code-action-committee-fcac/>

Cost Impact

The code change proposal will increase the cost of construction .

If approved this proposal will mandate protection of voids which do not require protection by the 2018 IBC.

Analysis: A review of the standard proposed for inclusion in the code, ASTM E2837-17, with regard to the ICC criteria for referenced standards (Section 3.6 of CP#28) will be posted on the ICC website on or before April 2, 2018.

Internal ID: 330

FS31-18

IBC: 202 (New), 202, 707.9, 715.6 (New), Chapter 35

Proponent: Michael O'Brian, Chair, representing FCAC (fcac@iccsafe.org)

2018 International Building Code

SECTION 202 DEFINITIONS

Add new definition as follows:

CONTINUITY HEAD-OF-WALL JOINT SYSTEM. An assemblage of specific materials or products that are designed to resist the passage of fire through voids created at the intersection of fire barriers and the underside of nonfire-resistance-rated roofs for a prescribed period of time.

Revise as follows:

[BF] F RATING. The time period that the through-penetration firestop system or continuity head-of-wall joint system limits the spread of fire through the penetration ~~when tested in accordance with ASTM E814 or UL 1479 or void.~~

[BF] T RATING. The time period that the penetration firestop system, including the penetrating item, or the continuity head-of-wall joint system limits the maximum temperature rise to 325°F (163°C/180°C) above its initial temperature through the penetration or void on the nonfire side ~~when tested in accordance with ASTM E814 or UL 1479 side.~~

707.9 Voids at intersections. The voids created at the intersection of a *fire barrier* and a nonfire-resistance-rated roof assembly or a nonfire-resistance-rated exterior wall assembly shall be filled. ~~An approved material or system shall be used to fill the void, and shall be securely installed in or on the intersection for its entire length so as not to dislodge, loosen or otherwise impair its ability to accommodate expected building movements and to retard the passage of fire and hot gases protected with a material or system which complies with Section 715.~~

Add new text as follows:

715.6 Voids at intersections of fire barriers and underside of nonfire-resistance-rated roofs. The voids created at the intersection of a fire barrier and the underside of a nonfire-resistance-rated roof sheathing, slab or deck above shall be protected by an approved continuity head-of-wall joint system installed as tested in accordance with ASTM E2837 to provide an F rating/T rating for a time period not less than the required fire-resistance rating of the wall assembly in which it is installed or be filled with an approved material or system. Such materials or systems shall be securely installed in accordance with the manufacturer's installation instructions in or on the void for its entire length so as not to dislodge, loosen or otherwise impair its ability to accommodate expected building movements and to resist the passage of fire and hot gases. Continuity head-of-wall joint systems shall also be installed in accordance with the listing criteria.

Add new standard(s) follows:

ASTM

ASTM International
100 Barr Harbor Drive, P.O. Box
C700
West Conshohocken PA 19428-
2959
US

E2837-17:

Standard Test Method for Determining the Fire Resistance of Continuity Head-of-Wall Joint Systems Installed Between Rated Wall Assemblies and Nonrated Horizontal Assemblies

Reason:

This proposal clarifies language for protecting voids at the intersection of a fire barrier and the underside of a nonfire-resistance-rated roof assembly as follows:

- Section 707.9 was revised to follow the format of Section 707.8, and the protection requirements were moved to Section 715.
- A new Section 715.5 includes the protection requirements previously in Section 707.9 for voids at intersections of

fire barriers and the underside of nonfire-resistance-rated roofs. In addition, Section 715.5 includes an option for protecting this void with a continuity head-of-wall joint system.

- A definition of continuity head-of-wall joint system was provided.
- The definitions of F rating and T rating were revised to reference continuity head-of-wall joint systems. In addition, reference to the two firestop test standards was removed from the definitions.
- The definition of T rating was revised to correct an error in the metric conversion of the temperature rise criteria. When converting a **temperature rise**, the equation is $^{\circ}\text{C} = 5/9(^{\circ}\text{F})$. The 32°F portion of the equation for converting actual temperatures falls out of the equation.
- ASTM E2837 was added as new referenced standard.
- There are currently approximately 20 continuity head-of-wall joint system tested and certified by UL meeting an F rating/T rating.
- This proposal to include ASTM E2837 test aligns with the requirements added in the 2018 edition of NFPA 101.

The proposal compliments a proposal which reorganizes Section 715.

This proposal is submitted by the ICC Fire Code Action Committee (FCAC). The FCAC was established by the ICC Board of Directors to pursue opportunities to improve and enhance assigned International Codes with regard to fire safety and hazardous materials in new and existing buildings and facilities and the protection of life and property in wildland urban interface areas. In 2017 the Fire-CAC has held 3 open meetings. In addition, there were numerous conference calls, Regional Work Group and Task Group meetings for the current code development cycle, which included members of the committees as well as any interested parties, to discuss and debate the proposed changes. Related documentation and reports are posted on the FCAC website at: <https://www.iccsafe.org/codes-tech-support/cs/fire-code-action-committee-fcac/>

Cost Impact

The code change proposal will not increase or decrease the cost of construction .

This proposal simply provides another option for demonstrating code compliance.

Analysis: A review of the standard proposed for inclusion in the code, ASTM E2837-17, with regard to the ICC criteria for referenced standards (Section 3.6 of CP#28) will be posted on the ICC website on or before April 2, 2018.

Internal ID: 326

FS32-18

IBC: 708.1

Proponent: Sarah Rice, representing Myself (srice@preview-group.com)

2018 International Building Code

Revise as follows:

708.1 General. The following wall assemblies shall comply with this section.

1. Separation walls as required by Section 420.2 for Group I-1 and Group R occupancies.
2. Walls separating tenant spaces in *covered and open mall buildings* as required by Section 402.4.2.1.
3. Corridor walls as required by Section 1020.1.
4. Enclosed elevator lobby separation as required by Section 3006.2.
5. Egress balconies as required by Section 1021.2
6. Walls separating ambulatory care facilities from adjacent spaces, corridors or tenants as required by Section 422.2

Reason:

Section 708.1 provides a list of the locations where fire partitions are required in the IBC. Missing from the list is the requirement found in Section 422.2 to separate ambulatory care facilities from adjacent spaces. This code change simply brings that requirement into the list.

IBC Section 422.2 reads:

422.2 Separation. Ambulatory care facilities where the potential for four or more care recipients are to be incapable of self-preservation at any time shall be separated from adjacent spaces, corridors or tenants with a fire partition installed in accordance with Section 708.

Cost Impact

The code change proposal will not increase or decrease the cost of construction .

The code change is simply a correlation.

Internal ID: 2373

FS33-18

IBC: 708.1

Proponent: Michael O'Brian, Chair, representing FCAC (fcac@iccsafe.org)

2018 International Building Code

Revise as follows:

708.1 General. The following wall assemblies shall comply with this section.

1. Separation walls as required by Section 420.2 for Group I-1 and Group R occupancies.
2. Walls separating tenant spaces in *covered and open mall buildings* as required by Section 402.4.2.1.
3. Corridor walls as required by Section 1020.1.
4. Enclosed elevator lobby separation as required by Section ~~3006.2~~3006.3.
5. Egress balconies as required by Section 1021.2
6. Walls separating ambulatory care facilities from adjacent spaces, corridors or tenants as required by Section 422.2.
7. Walls separating individual sleeping units and contiguous attic and crawl spaces to those units are separated from each other and public or common areas as required by Sections 907.2.8.1, 907.2.9.1 and 907.2.10.1.
8. Walls separating vestibules from a level of exit discharge as required by Section 1028.1.

Reason:

Section 708.1 describes the application of fire partitions as required by other sections of the code. This list has become outdated over time. This proposal updates this list by adding the additional sections which require walls to be constructed as fire partitions.

This proposal is submitted by the ICC Fire Code Action Committee (FCAC). The FCAC was established by the ICC Board of Directors to pursue opportunities to improve and enhance assigned International Codes with regard to fire safety and hazardous materials in new and existing buildings and facilities and the protection of life and property in wildland urban interface areas. In 2017 the Fire-CAC has held 3 open meetings. In addition, there were numerous conference calls, Regional Work Group and Task Group meetings for the current code development cycle, which included members of the committees as well as any interested parties, to discuss and debate the proposed changes. Related documentation and reports are posted on the FCAC website at: <https://www.iccsafe.org/codes-tech-support/cs/fire-code-action-committee-fcac/>

Cost Impact

The code change proposal will not increase or decrease the cost of construction .

The changes are editorial and do not add new construction requirements.

Internal ID: 331

FS34-18

IBC: 708.3, 708.3.1 (New), 708.4.1, 711.2.3, 711.2.4, 711.2.4.1, 711.2.4.1.1 (New), 711.2.4.3, 711.2.4.3.1 (New)

Proponent: Stephen Skalko, Stephen V. Skalko, P.E. & Associates, LLC, representing Masonry Alliance for Codes and Standards (svskalko@svskalko-pe.com); William Hall, Portland Cement Association, representing Alliance For Concrete Codes and Standards (jhall@cement.org)

2018 International Building Code

Revise as follows:

708.3 Fire-resistance rating. Except as provided in Section 708.3.1 Fire partitions shall have a fire-resistance rating of not less than 1 hour.

Add new text as follows:

708.3.1 Group I-1, R-1 and R-2 buildings. For Group I-1, R-1 and R-2 occupancies in buildings of Type III, IV and V construction that are more than two stories in height or that have dwelling or sleeping units located on a floor level that is more than 25-feet above the grade plane, the separation walls required by Section 420.2 shall be fire barriers that comply with Section 707 and shall have a 2-hour fire resistance rating. In addition, any load bearing walls shall meet the requirements of Section 1604 without sheathing.

Exceptions:

1. Corridor walls permitted to have a 1/2-hour fire-resistance rating by Table 1020.1.
2. Dwelling unit and sleeping unit separations in buildings of Types IIB, IIIB and VB construction shall have fire-resistance ratings of not less than ~~1/2~~ 1-hour in buildings equipped throughout with an automatic sprinkler system in accordance with Section 903.3.1.1.

Revise as follows:

708.4.1 Supporting construction. The supporting construction for a *fire partition* shall have a *fire-resistance rating* that is equal to or greater than the required fire-resistance rating of the supported *fire partition*.

Exception: In buildings of Types IIB, IIIB and VB construction, the supporting construction requirement shall not apply to 1-hour fire partitions separating tenant spaces in covered and open mall buildings, *fire partitions* separating dwelling units, *fire partitions* separating sleeping units and *fire partitions* serving as corridor walls.

711.2.3 Supporting construction. The supporting construction shall be protected to afford the required *fire-resistance rating* of the *horizontal assembly* supported.

Exception: In buildings of Type IIB, IIIB or VB construction, the construction supporting the *horizontal assembly* is not required to be fire-resistance rated at the following:

1. *Horizontal assemblies* at the separations of incidental uses as specified by Table 509 provided that the required *fire-resistance rating* does not exceed 1 hour.
2. ~~Horizontal~~ One-hour fire resistance rated horizontal assemblies at the separations of *dwelling units* and *sleeping units* as required by Section 420.3.

711.2.4 Fire-resistance rating. The *fire-resistance rating* of *horizontal assemblies* shall comply with Sections 711.2.4.1 through 711.2.4.6 but shall be not less than that required by the building type of construction.

711.2.4.1 Separating mixed occupancies. Except as provided in Section 711.2.4.1.1, Where the *horizontal assembly* separates mixed occupancies, the assembly shall have a *fire-resistance rating* of not less than that required by Section 508.4 based on the occupancies being separated.

Add new text as follows:

711.2.4.1.1 Group I-1, R-1 and R-2 buildings. For Group I-1, R-1 and R-2 occupancies in buildings of Type III, IV and V construction that are more than two stories in height or that have dwelling or sleeping units located on a floor level that is more than 25-feet above grade plane, the horizontal assemblies providing the separations of dwelling and sleeping units as required by Section 420.3 shall have a 2-hour fire resistance rating. In addition, any load bearing walls supporting the horizontal assembly shall comply with the requirements of Section 1604 without the use of sheathing.

711.2.4.3 Dwelling units and sleeping units. Except as provided in Section 711.2.4.3.1, *Horizontal assemblies* serving as dwelling or sleeping unit separations in accordance with Section 420.3 shall be not less than 1-hour *fire-resistance-rated* construction.

711.2.4.3.1 Group I-1, R-1 and R-2 buildings. For Group I-1, R-1 and R-2 occupancies in buildings of Type III, IV and V construction that are more than two stories in height or that have dwelling or sleeping units located on a floor level that is more than 25-feet above grade plane, the horizontal assemblies at the separation of dwelling and sleeping units as required by Section 420.3 shall have a 2-hour fire resistance rating. In addition, any load bearing walls supporting the horizontal assemblies shall meet the requirements of Section 1604 without the use of sheathing.

Exception: Horizontal assemblies separating dwelling units and sleeping units shall be not less than 1 -hour fire-resistance-rated construction in a building of Types IIB, IIIB and VB construction, where the building is equipped throughout with an automatic sprinkler system in accordance with Section 903.3.1.1.

Reason:

The changing construction methods and the noticeable shift to light weight materials for Group I-1, R-1 and R-2 occupancy buildings; and the continued national trend in reducing fire department staffing numbers, this proposed code language provides for two distinct safety provisions. The first is the increased compartmentalization of the building to reduce fire spread and damage using passive fire protection methods. The second safety provision is the ability of the structure to be constructed in such a way that it retains its structural integrity after being subject to a fire. The provisions of **Section 101.3 Intent**, state:

“The purpose of this code is to establish the minimum requirements to safeguard the public health, safety and general welfare through structural strength, means of egress facilities, stability, sanitation, adequate light and ventilation, energy conservation, and safety to life and property from fire and other hazards attributed to the built environment and to provide safety to fire fighters and emergency responders during emergency operations.”

Currently many of these load bearing walls are constructed in such a way that the wall sheathing is a critical part of the structural integrity of the wall. The sheathing is used for localized member stability, global stability, and in many cases the lateral load resisting system for the entire building. During an adverse event, such as a fire this sheathing can be compromised by fire damage, mechanical damage, and water damage compromising the overall structural integrity of the building. Where the current standard test used for fire resistance is the ASTM E119, Standard Test Methods for Fire Tests of Building Construction and Materials, in practice this test does not account for the reduction in strength and stiffness that results from fire and water damage. It is not practical to think that every assembly would be tested at designed load levels and the resulting strength and stiffness data used in design, as a result the proposed provisions would provide for the structure to rely on the sheathing only as a fire resistive element and would allow the structure to maintain its design strength after the sheathing was compromised or removed for any reason.

The proposed story level and floor height is based on the ability for a fire department to make a rescue from the exterior of the structure using the equipment commonly found on an NFPA 1901 equipped motorized fire engine, this using the most common extension ladder size, being a 24 foot long extension ladder which can easily reach a second floor window. In addition, for structures three stories or greater in height, the level of vertical load and potential lateral load on these walls increases and as a result an additional level of safety is needed.

The success of NFPA 13 & 13R sprinkler systems to manage and control fire is acknowledged however, the provisions of this code change are designed to assist those active fire protection systems in effectively doing their job and to provide structural stability and strength that is dictated under the provisions of Section 101.3.

Cost Impact

The code change proposal will not increase or decrease the cost of construction .

Based on an independent third-party study of rectangular 4-story Type V multi-family dwellings if constructed in three different cities, this code change proposal may or may not increase the cost of construction, depending on location and material costs at the time of the construction.

A multi-family residential structure must be schematically designed to meet all of the requirements of the 2015 International Building Code to accurately evaluate the relative construction cost. Once designed, the cost comparison buildings were reviewed for code compliance, and cost estimates prepared. The study was prepared Walter G. M. Schneider III, Ph.D., P.E., MCP, CBO, CFO and Ryan L. Solnosky, Ph.D., P.E.

The building model chosen for the project was a 4 story multi-family residential structure encompassing approximately 25,000 gross square feet of building area per floor. The cost comparisons are based on the proposed target building assembled using a mixed bedroom scheme for residential occupancies.

The following construction types were included in the evaluation:

Conventional wood framing with floor system (Type VA construction)

Light gauge steel framing with concrete slab floor on steel deck (Type IIB construction)

Load bearing concrete masonry with precast concrete floor (Type IIB construction)

Load-bearing precast concrete walls and precast concrete floor (Type IIB construction)

Load-bearing insulated concrete form (ICF) walls* and precast concrete floor (Type IIB construction)

Load-bearing insulated concrete form (ICF) walls* and ICF concrete floor (Type IIB construction)

* For the ICF systems walls separating dwelling units were specified as concrete masonry.

The cost estimate for each building model included the complete fit out of each building with the exception of movable appliances and furniture.

From the cost estimates for the 3-city study, the report concluded that the compartmentalized construction method utilizing concrete based construction materials was cost competitive with light weight conventional wood frame construction.

Copies of the study are available on request.

Internal ID: 1597

FS35-18

IBC: 708.3, 711.2.4.3

Proponent: William Hall, Portland Cement Association, representing Alliance For Concrete Codes and Standards (jhall@cement.org); Jason Thompson, National Concrete Masonry Association, representing Masonry Alliance for Codes and Standards (jthompson@ncma.org)

2018 International Building Code

Revise as follows:

708.3 Fire-resistance rating. *Fire partitions used to separate dwelling units and sleeping units shall have fire-resistive ratings of not less than 2 hours. Other fire partitions shall have a fire-resistance rating of not less than 1 hour.*

Exceptions:

1. Corridor walls permitted to have a $1\frac{1}{2}$ -hour fire-resistance rating by Table 1020.1.
2. *Dwelling unit and sleeping unit separations in buildings of Types ~~II~~, ~~III~~ and ~~VB~~ construction shall have fire-resistance ratings of not less than ~~1~~/~~2~~-~~1~~ hour in buildings equipped throughout with an automatic sprinkler system in accordance with Section 903.3.1.1.*

711.2.4.3 Dwelling units and sleeping units. *Horizontal assemblies serving as dwelling or sleeping unit separations in accordance with Section 420.3 shall be not less than ~~1~~/~~2~~-hour fire-resistance-rated construction.*

Exception: *Horizontal assemblies separating dwelling units and sleeping units shall be not less than $1\frac{1}{2}$ -hour fire-resistance-rated construction in a building of Types ~~II~~, ~~III~~, ~~IV~~ and ~~V~~ construction, where the building is equipped throughout with an automatic sprinkler system in accordance with Section 903.3.1.1.*

Reason:

Reductions in passive fire protection, especially between dwelling units has long been a concern of our members and allies. Our fears are unfortunately coming true as the U.S. is beginning to see occupied structures with sprinkler protection experiencing substantial or complete burn out as well as deaths and injuries. Westchester, PA 4 seniors killed, Chesapeake, VA 3 killed, Evans, GA 1 killed. Survivors are forced to re-locate and start over. See attachment for complete list.

This proposal returns the requirement for a 2- hour fire rating between dwelling and sleeping units while still recognizing the increased reliability of NFPA 13 systems. We feel this is a good compromise to return a level of redundancy into the code for our citizens who depend on this code for not only life safety but also for property protection within their space they call home. The requirements in this proposals can easily be met by any of the material industries. Note that this requirement is applicable to all construction types except for Type I horizontal assemblies. Type I requires a 2 hour floor rating regardless. Because of that, including Type I in the 711.2.4.3 would result in a reduction of hourly rating and reduction in safety.

In a perfect world we could all rely on active fire suppression systems and that proper maintenance and monitoring would occur, the system will always suppress the fire regardless of added obstructions. That simply is not the case. We live in a world where many times Murphy's Law presides and if the chance exists it can and will happen. Providing a 2 hour or 1 hour in the case of NFPA 13, will enhance the structures ability to withstand fire and provide more time for residents to recognize the emergency and escape and fire service personnel to perform recovery operations.

Cost Impact

The code change proposal will increase the cost of construction .

The added cost will typically be limited to providing an additional layer of type x gypsum to each side of the wall assembly or ceiling assembly serving as the dwelling unit separation.

Internal ID: 618

FS36-18

IBC: 708.4

Proponent: Paul Battaglia, STC Sound Control, representing STC Sound Control, President
(paul@stcsoundcontrol.com)

2018 International Building Code

Revise as follows:

708.4 Continuity. Fire partitions shall extend from the top of the foundation or floor/ceiling assembly below and be securely attached to one of the following:

1. The underside of the floor or roof sheathing, deck or slab above.
2. The underside of a floor/ceiling or roof/ceiling assembly having a fire-resistance rating that is not less than the fire-resistance rating of the fire partition.

Exceptions:

1. Fire partitions shall not be required to extend into a crawl space below where the floor above the crawl space has a minimum 1-hour fire-resistance rating.
2. Fire partitions serving as a corridor wall shall not be required to extend above the lower membrane of a corridor ceiling provided that the corridor ceiling membrane is equivalent to corridor wall membrane, and either of the following conditions is met:
 - 2.1. The room-side membrane of the corridor wall extends to the underside of the floor or roof sheathing, deck or slab of a fire-resistance-rated floor or roof above.
 - 2.2. The building is equipped with an automatic sprinkler system installed throughout in accordance with Section 903.3.1.1 or 903.3.1.2, including automatic sprinklers installed in the space between the top of the fire partition and underside of the floor or roof sheathing, deck or slab above.
3. Fire partitions serving as a corridor wall shall be permitted to terminate at the upper membrane of the corridor ceiling assembly where the corridor ceiling is constructed as required for the corridor wall.
4. Fire partitions separating tenant spaces in a covered or open mall building complying with Section 402.4.2.1 shall not be required to extend above the underside of a ceiling. Such ceiling shall not be required to be part of a fire-resistance-rated assembly, and the attic or space above the ceiling at tenant separation walls shall not be required to be subdivided by fire partitions.
5. Fire partitions shall be permitted to extend from the top of a floor underlayment system that is not a component of the floor/ceiling assembly where the building is equipped with an automatic sprinkler system installed throughout in accordance with Section 903.3.1.1 or 903.3.1.2.

Reason:

This proposal is intended to allow continuous installation of floor underlayment systems, such as those required for impact noise isolation, without compromise to fire safety in buildings. Continuous installation will save 13% of system cost and speed construction. It will also provide isolation of structure-borne sound not possible with discontinuous underlayment installation.

Acoustical underlayment systems are required by IBC 1207.3 to attain high Impact Isolation Classification (IIC) ratings for floors in facilities with dwelling units and sleeping rooms. Continuous installation of underlayment is currently an integral part of many fire-rated floor/ceiling systems that include gypsum cement poured over acoustical mats, recycled newspaper mats, and plywood panels installed over rubber pads (ex: UL Design L563).

Fire partitions may be placed directly on top of these fire-rated floor/ceiling systems under the current IBC 708.4 since they are part of the fire-resistance rated floor/ceiling assemble. There is no difference in construction details or fire behavior between adjacent rooms when fire partitions are placed on top of the underlayment systems whether the underlayment system is integral to the floor/ceiling system or it isn't.

We propose that fire partitions should be allowed to be placed directly on these underlayment systems where they are not a part of the fire-rated system, especially where automatic sprinkler systems are installed. Furthermore, an underlayment system that performs as a component of a fire-rated floor/ceiling assembly will provide additional fire

safety when added to an otherwise complete assembly.

Continuous installation of underlayment provides the additional benefit of structure-borne sound isolation between floors by creating a discontinuous path for sound and vibration between the underlayment and the subfloor.

Cost Impact

The code change proposal will decrease the cost of construction .

Under current Code requirements a fire-rated partition must be installed on the top of the floor/ceiling assembly prior to placing the additional underlayment. The proposal will allow installation of underlayment systems over an entire building floor system prior to construction of any partitions, thus eliminating additional cutting and fitting around in-place partitions that add 13% to the system cost. It will also eliminate interruptions in the installation process and the related and unnecessary costs of remobilization.

	Fire Partitions in Place	Continuous Installation
Total Floor Area of Underlayment	11,240	11,586
Perimeter Length	1,943	564
Full Panels @ 4x8	352	363
Pads in Field @ 10 per panel	3,520	3,630
Pads at Perimeter @ 2	972	282
Total Pads	4,492	3,912
Panel Cuts (feet) @ perimeter	1,943	564
Manhours for cuts @ 1.2 minutes/foot	39	11
Perimeter panels installed @ 4'	486	141
Material cost of pads @ \$0.9556	\$ 4,292.08	\$ 3,738.31
Material cost of panels @ \$31.16	\$ 10,968.32	\$ 11,311.08
Manhours: Pads @ 80/hour	56	49
Manhours: Panels @ 15/hour	56	34
Total Manhours	151	94
Total Material Costs	\$ 15,260.40	\$ 15,049.39
Total Labor Costs @ \$32/hour	\$ 4,827.32	\$ 3,000.96
Total Cost per Square Foot	\$ 1.79	\$ 1.56
Savings for continuous (%)	13%	
Per square foot savings	\$ 0.23	

Internal ID: 130

FS37-18

IBC: 708.4.1

Proponent: Sarah Rice, representing Myself (srice@preview-group.com)

2018 International Building Code

Revise as follows:

708.4.1 Supporting construction. The supporting construction for a *fire partition* shall have a *fire-resistance rating* that is equal to or greater than the required fire-resistance rating of the supported *fire partition*.

Exception: In buildings of Types IIB, IIIB and VB construction, the supporting construction requirement shall not apply to *fire partitions* separating tenant spaces in covered and open mall buildings, *fire partitions* separating dwelling units, *fire partitions* separating sleeping units, *fire partitions separating ambulatory care facilities from adjacent spaces or corridors,* and *fire partitions* serving as corridor walls.

Reason:

When the CTC Working Group on ambulatory care put together what is now Section 422, the correlative changes appropriate for fire partitions were not made. This code change brings in those changes.

Currently the IBC literally requires the supporting construction for fire partitions in Type IIB, IIIB and VB construction used to separate ambulatory care facilities to be fire rated the same as the wall.

Cost Impact

The code change proposal will decrease the cost of construction .

Currently there is no exception for the supporting construction of fire partitions separating ambulatory care facilities from other areas, thus it is literally required to be fire rated. Providing the exception reduces cost through fewer materials in the supporting construction.

Internal ID: 2375

FS38-18

IBC: SECTION 202, 202, 709.4.1

Proponent: John Williams, Chair, representing Healthcare Committee (AHC@iccsafe.org); Michael O'Brian, Chair, representing FCAC (fcac@iccsafe.org)

2018 International Building Code

SECTION 202 DEFINITIONS

Revise as follows:

[BG] SMOKE COMPARTMENT. ~~A space within a building enclosed by smoke barriers on all sides, including the top and bottom, separated from other interior areas of the building by smoke barriers, including interior walls and horizontal assemblies.~~

709.4.1 Smoke-barrier walls-assemblies separating smoke compartments. ~~Smoke-barrier walls-assemblies used to separate smoke compartments shall form an effective membrane enclosure that is continuous from outside wall or smoke barrier wall to outside wall or another smoke barrier wall and horizontal assemblies.~~

Reason:

Modification of the definition is better describing the intent and means of defining the smoke compartment. It further clarifies that the separation is to occur between interior areas of the building and not require a roof or exterior wall to meet the requirements of a smoke barrier.

Proposed modifications to Section 709.4.1 reflect that smoke barriers used for creating smoke compartments and separating them from other interior areas of the building, is not accomplished by just walls, but horizontal assemblies may also be required. The use of vertical and horizontal components is clearly noted in Sections 709.1 and 711.2.4.4. Changing that smoke barrier walls can “begin and end” at another smoke barrier wall, instead of just outside wall to outside wall provides an increase design flexibility in all types of care facilities. It also is comparable to the language for separation of areas of refuge and elevator lobbies in Section 709.4.2.

This proposal is submitted by the ICC Fire Code Action Committee (FCAC), and ICC Committee on Healthcare (CHC).

The FCAC was established by the ICC Board of Directors to pursue opportunities to improve and enhance assigned International Codes with regard to fire safety and hazardous materials in new and existing buildings and facilities and the protection of life and property in wildland urban interface areas. In 2017 the Fire-CAC has held 3 open meetings. In addition, there were numerous conference calls, Regional Work Group and Task Group meetings for the current code development cycle, which included members of the committees as well as any interested parties, to discuss and debate the proposed changes. Related documentation and reports are posted on the FCAC website at: <https://www.iccsafe.org/codes-tech-support/cs/fire-code-action-committee-fcac/>

The CHC was established by the ICC Board to evaluate and assess contemporary code issues relating to healthcare facilities. This is a joint effort between ICC and the American Society for Healthcare Engineering (ASHE), a subsidiary of the American Hospital Association, to eliminate duplication and conflicts in healthcare regulation. In 2017 the CHC held 2 open meetings and numerous conference calls, which included members of the committees as well as any interested parties, to discuss and debate the proposed changes. Information on the CHC, including: meeting agendas; minutes; reports; resource documents; presentations; and all other materials developed in conjunction with the CHC effort can be downloaded from the CHC website at: <https://www.iccsafe.org/codes-tech-support/cs/icc-committee-on-healthcare/>.

Cost Impact

The code change proposal will decrease the cost of construction .

Proposed changes will reduce the cost of construction as exterior walls and roofs will no longer need to perform as “smoke barrier assemblies” as the present language has been interpreted to require. It also eliminates the need for smoke barrier walls to be constructed through the building to an outside wall. Potentially increasing the size of the smoke compartment and creating an increase in the construction of mechanical systems that could have been outside of the space if the walls would have been permitted to terminate at another smoke barrier instead of an outside wall.

Internal ID: 605

FS39-18

IBC: 710.5, 710.5.3 (New)

Proponent: John Williams, Chair, representing Healthcare Committee (AHC@iccsafe.org)

2018 International Building Code

Revise as follows:

710.5 Openings. Openings in smoke partitions shall comply with Sections 710.5.1 and ~~710.5.2~~ through 710.5.3

Add new text as follows:

710.5.3 Pass through openings in Group I-2 Condition 2. Where pass through openings are provided in smoke partitions in Group I-2, Condition 2 occupancies, such openings shall comply with the following:

1. Smoke compartment in which the pass through openings occur do not contain a patient care suite or sleeping room.
2. Pass through openings are installed in a door or vision panel that is not required to have a fire protection rating.
3. The top of the pass through opening is located a maximum of 48 inches above the floor.
4. The aggregate area of all such pass through openings within a single room shall not exceed 80 square inches (0.05m²).

Reason:

At Section 710.5.3, the addition of pass through openings is to recognize important operational functions in the context of the corridor wall. There are several examples of this operational practice. Hospital pneumatic tube delivery systems cannot handle some materials and others where the shaking of the material compromises its effectiveness. In particular, chemotherapy, gross lab materials (tissue biopsy, small organ, etc.) and cash / checks are restricted from being delivered via pneumatic tube system, which is why walk-up pickup and delivery is still an important operational feature of some areas.

First, in a hospital pharmacy, air pressure relationships are established to keep a safe environment. From an operational standpoint, there are frequent pickups by patient care staff from an in-house pharmacy that require direct hand-off and signing of forms. In addition, there are basic security requirements from DEA and state pharmacy boards that require the pharmacy material to be secured, whether it is narcotics, opioids or chemotherapy materials. Opening and closing the door compromises the air relationships prescribed by the IMC Section 407.1, as well as security.

In a laboratory setting, air pressure relationships are critical, and many samples get delivered by hand through a pass-through. Cashier areas are set like a secured bank windows, due to the co-payment cash being delivered by staff, or a patient with a financial issue to be discussed.

This concept has existed in hospitals for a long time, because it has been allowed by the federal standard (K364). This code changes seeks to establish the same criteria to respond to the operational need of the corridor, while maintaining its integrity.

This proposal is submitted by the ICC Committee on Healthcare (CHC). The CHC was established by the ICC Board to evaluate and assess contemporary code issues relating to healthcare facilities. This is a joint effort between ICC and the American Society for Healthcare Engineering (ASHE), a subsidiary of the American Hospital Association, to eliminate duplication and conflicts in healthcare regulation. In 2017 the CHC held 2 open meetings and numerous conference calls, which included members of the committees as well as any interested parties, to discuss and debate the proposed changes. Information on the CHC, including: meeting agendas; minutes; reports; resource documents; presentations; and all other materials developed in conjunction with the CHC effort can be downloaded from the CHC website at: <https://www.iccsafe.org/codes-tech-support/cs/icc-committee-on-healthcare/>.

Cost Impact

The code change proposal will increase the cost of construction .

Costs will increase with this change because it allows extra features to be added to an opening. However, it does not add cost to the healthcare industry because we already follow these requirements in the context of the federal standard.

FS40-18

IBC: 713.4

Proponent: Jeffrey Hugo, representing National Fire Sprinkler Association (hugo@nfsa.org)

2018 International Building Code

Revise as follows:

713.4 Fire-resistance rating. Shaft enclosures shall have a *fire-resistance rating* of not less than 2 hours where connecting four *stories* or more, and not less than 1 hour where connecting less than four *stories*. The number of *stories* connected by the shaft enclosure shall include any basements but not any *mezzanines*. Shaft enclosures shall have a *fire-resistance rating* not less than the floor assembly penetrated, but need not exceed 2 hours. Shaft enclosures shall meet the requirements of Section 703.2.1.

Exception: For buildings with automatic sprinkler systems in accordance with 903.3.1.1, not greater than 420 feet (128 m) in building height, the required fire-resistance rating of the fire barriers enclosing vertical shafts, other than interior exit stairways and elevator hoistways, shall not be less than 1 hour where automatic sprinklers are installed within the shafts at the top and alternate floors. Each floor throughout the building shall be equipped with sprinkler control valves equipped with supervisory initiating and water-flow initiating devices.

Reason:

The text of the new exception to IBC Section 713.4, comes from IBC Section 403.2.1.2. Section 403.2.1.2 allows shafts in high-rises (over 75 ft in height) up to 420 feet in height to have a 1-hour rating where the building is fully sprinklered, with sprinklers at the top of the shaft and alternating floor levels. Each floor has a supervised floor control valves and water flow switches. This proposals extends the same requirement to all shafts (except stairs and elevators) of any building. This exception would only apply to NFPA 13 sprinklered buildings, with the addition of supervised floor control valves, water flow switches and sprinklers at the top of the shaft and at each alternate level. NFPA 13 does not require low-rise buildings to be equipped with floor control valves on each floor (NFPA 13, 8.2.4) and shafts with noncombustible or limited-combustible (gypsum board) surfaces are not required to have sprinklers (NFPA 13 8.15.2).

The high-rise shaft reduction language can be traced back to the 1990 BOCA code. There are no records of adverse or failures of the active or passive measures when this reduction is used. It can be reasoned that a 76 ft building (a high-rise) can have sprinklered 1-hr shafts whereas a 75 ft building (not a high-rise) would be required to have 2-hr shafts without the codified option or exception to allow a reduction for sprinklers.

Cost Impact

The code change proposal will increase the cost of construction .

This proposal correlates the requirement for high-rise shaft rating reduction to all shafts. To obtain the reduction for buildings under 75 ft, an automatic sprinkler system per NFPA 13 is required, as well as supervised floor control valves, water flow switches and sprinklers at the top of the shaft and at each alternating level. A low-rise building (2-4 stories) can be sprinklered without supervised floor control valves, water-flow for each floor. This text provides an option to a building designer and owner where the additional expense warrants a reduction in shaft rating.

Internal ID: 1230

FS41-18

IBC: 713.12

Proponent: Kellie Saylor, OZ Architecture, representing Code Change Committee of Colorado Chapter of the International Code Council (ksaylor@ozarch.com)

2018 International Building Code

Revise as follows:

713.12 Enclosure at top. ~~A shaft enclosure that does not~~ The top of shaft enclosures shall comply with one of the following:

1. They shall extend to the underside of the roof sheathing, deck or slab of the building and the roof assembly shall comply with the requirements for the type of construction as specified in Table 601.
2. They shall terminate below the roof assembly and be enclosed at the top with construction of the same fire-resistance rating as the topmost floor penetrated by the shaft, but not less than the fire-resistance rating required for the shaft enclosure.
3. They shall extend past the roof assembly and comply with the requirements of Section 1510.

Reason:

The current phrasing in this section can be confusing and it does not address one of the most common conditions at the top of a shaft enclosure. The previous section, 713.11 Enclosure at bottom, identifies the most common conditions at the bottom of a shaft enclosure and clearly lists the requirements for each condition. This proposed change to the Enclosure at top section aims to provide the same level of detail and organization as the Enclosure at bottom section. This proposal does not result in a technical change to the code requirements, but it does attempt to make those requirements more clear.

Three different conditions are identified for the top of a shaft enclosure in this proposal - the shaft enclosure can 1) extend to the underside of the sheathing, 2) terminate below the roof assembly or 3) extend past the roof assembly. The requirements for conditions one and two can be inferred from the current code language. However, the requirements for the third condition are not currently identified in this section. When a shaft enclosure extends past the roof assembly, it would then meet the definition of a Penthouse and need to meet the requirements of section 1510 Rooftop Structures. It is a common condition for elevator shafts to extend past the roof and it deserves mention in section 713.12 Enclosure at top. The proposal adds this third condition and includes a reference to section 1510 Rooftop Structures. Additionally, the first condition (where a shaft enclosure extends to the underside of the sheathing) has been expanded to note that the roof must meet the requirements for the type of construction specified.

Cost Impact

The code change proposal will not increase or decrease the cost of construction .

The code change proposal will not increase or decrease the cost of construction. This code change proposal does not result in a technical change to the code requirements but does make some of those requirements more clear. Since these requirements are already part of the code, it is not likely that there will be an increase or decrease in the cost of construction.

Internal ID: 312

FS42-18

IBC: 713.12.1 (New)

Proponent: David Collins, The American Institute of Architects, representing The American Institute of Architects (dcollins@preview-group.com)

2018 International Building Code

713.12 Enclosure at top. A shaft enclosure that does not extend to the underside of the roof sheathing, deck or slab of the building shall be enclosed at the top with construction of the same *fire-resistance rating* as the topmost floor penetrated by the shaft, but not less than the *fire-resistance rating* required for the shaft enclosure.

Add new text as follows:

713.12.1 Penthouse mechanical rooms. A fire/smoke damper shall not be required at the penetration of the rooftop structure where shaft enclosures extend up through the roof assembly into a rooftop structure conforming to Section 1510. All ductwork in the shaft shall be connected directly to HVAC equipment.

Reason:

The code includes provisions for termination of a shaft at the bottom and a shaft that terminates short of the roof assembly, but provides no guidance for a shaft that penetrates a roof structure. This change will clearly allow a shaft to terminate above the roof and ducts to connect the shaft to the HVAC equipment without any additional protection at the penetration of the roof when it is inside a rooftop structure permitted by Section 1510.

Cost Impact

The code change proposal will decrease the cost of construction .

By clarifying how shafts are terminated at the top should reduce the cost of construction, confusion and unnecessary installation of dampers. Criteria for shutdown of systems by detectors and dampers are found in the IMC and would suffice where the ductwork in the shaft connect to that equipment.

Internal ID: 1753

FS43-18

IBC: 713.13, 713.13.1

Proponent: Lawrence Lincoln, Salt Lake City Corporation, representing self (larry.lincoln@slcgov.com)

2018 International Building Code

Revise as follows:

713.13 Waste and linen chutes and incinerator rooms. Waste and linen chutes shall comply with the provisions of NFPA 82, Chapter 6 and shall meet the requirements of Sections 712 and 713.13.1 through 713.13.6. Incinerator rooms shall meet the provisions of Sections 713.13.4 through 713.13.5.

Exception-Exceptions:

1. Chutes serving and contained within a single dwelling unit.
2. Doors between the chute discharge and the discharge room shall not be required.

713.13.1 Waste and linen. A shaft enclosure containing a recycling, or waste or linen chute shall not be used for any other purpose and shall be enclosed in accordance with Section 713.4. A shaft enclosure shall be permitted to contain recycling and waste chutes. Openings into the shaft, from access rooms ~~and discharge rooms~~, shall be protected in accordance with this section and Section 716. Openings into chutes shall not be located in *corridors*. Doors into chutes shall be self-closing. ~~Discharge doors shall be self or automatic closing upon the actuation of a smoke detector in accordance with Section 716.2.6.6, except that heat activated closing devices shall be permitted between the shaft and the discharge room.~~

Reason:

Why is the IBC requiring waste and linen chute discharge doors to be fire-rated when the chute itself is not required to be fire-rated? As it is written, IBC code section 713.13 is trying to protect a building component (the chute) which is not a fundamental building element of construction. (See illustration). The addition of exception #2 eliminates the requirement of the chute discharge doors in its entirety along with the fire-rating as required by NFPA 82, Chapter 6. It is not the intention of this exception to eliminate NFPA 82, Chapter 6 in its entirety but only that portion of NFPA 82, Chapter 6 that requires the chute discharge doors and its fire rating. (See IBC section 102.4.1 concerning 'Conflicts' between referenced codes and standards, and the code. It indicates that the provisions of the code shall apply).

The strikeout of the words 'and discharge rooms' in section 713.13.1 eliminates the requirement for any type of fire-rated door at the bottom of the shaft where the shaft connects to the discharge room. IBC section 713.13.4 already requires that the waste and linen discharge room have the same fire-rating as the shaft enclosure that contains the chute. If the shaft enclosure and the discharge room are required to have the same fire rating, where is the need for a fire-rated door at that location? There is no need, nor is there a need for a waste and linen chute discharge door, let alone a fire-rated waste and linen chute discharge door.



Cost Impact

The code change proposal will decrease the cost of construction .

This proposed code changes eliminates a requirement therefore it would decrease the cost of construction.

Internal ID: 1998

FS44-18

IBC: 713.13, 713.13.1, 713.13.3, 713.13.4

Proponent: Sarah Rice, The Preview Group, representing Myself (srice@preview-group.com)

2018 International Building Code

Revise as follows:

713.13 Waste, recycle and linen chutes and incinerator rooms. Waste, recycle and linen chutes shall comply with the provisions of NFPA 82, Chapter 6 and shall meet the requirements of Sections 712 and 713.13.1 through 713.13.6. Incinerator rooms shall meet the provisions of Sections 713.13.4 through 713.13.5.

Exception: Chutes serving and contained within a single dwelling unit.

713.13.1 Waste, recycle and ~~linen~~-linen chute enclosures. A shaft enclosure containing a recycling, or waste or linen chute shall not be used for any other purpose and shall be enclosed in accordance with Section 713.4. A shaft enclosure shall be permitted to contain recycling and waste chutes. Openings into the shaft, from access rooms and discharge rooms, shall be protected in accordance with this section and Section 716. Openings into chutes shall not be located in *corridors*. Doors into chutes shall be self-closing. Discharge doors shall be self- or automatic-closing upon the actuation of a smoke detector in accordance with Section 716.2.6.6, except that heat-activated closing devices shall be permitted between the shaft and the discharge room.

713.13.3 Chute access rooms. Access openings for waste, recycling or linen chutes shall be located in rooms or compartments enclosed by not less than 1-hour *fire barriers* constructed in accordance with Section 707 or *horizontal assemblies* constructed in accordance with Section 711, or both. Openings into the access rooms shall be protected by opening protectives having a *fire protection rating* of not less than $3/4$ hour. Doors shall be self- or automatic-closing upon the detection of smoke in accordance with Section 716.2.6.6. The room or compartment shall be configured to allow the access door to the room or compartment to close and latch with the access panel to the ~~refuse or laundry~~ chute in any position.

713.13.4 Chute discharge room. Waste, recycling or linen chutes shall discharge into an enclosed room separated by *fire barriers* with a *fire-resistance rating* not less than the required fire rating of the shaft enclosure and constructed in accordance with Section 707 or *horizontal assemblies* constructed in accordance with Section 711, or both. Openings into the discharge room from the remainder of the building shall be protected by opening protectives having a *fire protection rating* equal to the protection required for the shaft enclosure. Doors shall be self- or automatic-closing upon the detection of smoke in accordance with Section 716.2.6.6. Waste chutes shall not terminate in an incinerator room. Waste and linen rooms that are not provided with chutes need only comply with Table 509.

Reason:

Previous code changes introduced "recycling chutes" to Section 713.13.1, but not the parent section, Section 713.1, or the sections for chute access or chute discharge rooms.

With the desire to be more environmentally conscious, building owners are incorporating more "built-in" mechanisms to promote the recycling of materials, such as dedicated chutes for the ready disposal of recyclable materials.

This proposal is somewhat editorial in nature as it only seeks to add consistency between the section on chute design in 713.

Cost Impact

The code change proposal will not increase or decrease the cost of construction .

As the 2018 IBC specifically regulates the overall construction of recycling chutes in the same manner as waste or linen chutes, there should not be any increase in cost.

Internal ID: 2369

FS45-18

IBC: 713.13.1, 713.13.4

Proponent: Todd Snider, West Coast Code Consultants (WC3), representing Self (Todd@KimballEng.com)

2018 International Building Code

Revise as follows:

713.13.1 Waste and linen. A shaft enclosure containing a recycling, or waste or linen chute shall not be used for any other purpose and shall be enclosed in accordance with Section 713.4. A shaft enclosure shall be permitted to contain recycling and waste chutes. Openings into the shaft, from access rooms ~~and discharge rooms~~, shall be protected in accordance with this section and Section 716. Openings into the shaft from the discharge room shall be protected in accordance with NFPA 82, Chapter 6. Openings into chutes shall not be located in *corridors*. Doors into chutes shall be self-closing. Discharge doors shall be self-or automatic-closing upon the actuation of a smoke detector in accordance with Section 716.2.6.6, except that heat-activated closing devices shall be permitted between the shaft and the discharge room.

713.13.4 Chute discharge room. Waste or linen chutes shall discharge into an enclosed room separated by *fire barriers* with a *fire-resistance rating* not less than the required fire rating of the shaft enclosure and constructed in accordance with Section 707 or *horizontal assemblies* constructed in accordance with Section 711, or both. Openings into the discharge room from the remainder of the building and from the shaft shall be protected by opening protectives having a *fire protection rating* equal to the protection required for the shaft enclosure. Doors shall be self-or automatic-closing upon the detection of smoke in accordance with Section 716.2.6.6. Waste chutes shall not terminate in an incinerator room. Waste and linen rooms that are not provided with chutes need only comply with Table 509.

Reason:

Proposed revision to clarify the requirements for opening protection between the shaft and the chute discharge room and to revise to match the requirements of the NFPA 82 standard referenced in Section IBC 713.13. The code currently requires that openings between the shaft and the discharge room to be protected per IBC 716, this requirement is not clear in the language of the code in this section, additionally, the requirements of IBC 716 do not match the requirements of Section 6.3.2.1 of NFPA 82. IBC 716 requires a fire rated door which has a closer and latch that is fire tested. Section 6.3.2.1 of NFPA 82 requires an approved automatic closing or self-closing door or fire damper of construction that is equivalent to the opening fire protection rating for the chute. The factory listed chute doors at the discharge cannot meet the latch requirements for the tested assemblies per IBC 716.

Cost Impact

The code change proposal will not increase or decrease the cost of construction .

This change simply clarifies a requirement that is already existing.

Internal ID: 1276

FS46-18

IBC: SECTION 202, 202 (New), 714.2.1 (New)

Proponent: William Koffel, representing Firestop Contractors International Association (wkoffel@koffel.com)

2018 International Building Code

SECTION 202 DEFINITIONS

Add new definition as follows:

FIRESTOP IDENTIFICATION DEVICE A label or placard, of any type, that identifies the firestop system.

Add new text as follows:

714.2.1 Firestop identification devices. Penetration firestop systems shall be permanently identified with a device, label or other method. The device shall be handwritten with permanent ink, or pre-printed, legible tag or label, or format readable by an electronic device. The device shall be located on both sides of the fire barrier, smoke barrier or fire wall. The device shall at a minimum have the following information:

1. Listing system number or engineering judgement number.
2. Date of Installation
3. Installing company name, contact information.
4. Manufacturer name of the firestop system.
5. "Warning, Penetration Firestop System - Do Not Remove or Tamper.

Adhesive or mechanically attached Identification devices shall be located within 6 inches (150 mm), of the penetration firestop system edge, on top of the horizontal assembly, 6 inches (150 mm) below or beside the firestop system. For multiple penetrations of the same listing number arranged within 6 inches (150 mm) of each other, the device shall be located centered under or within 6 inches (150 mm) to either side of the grouping. Hanging tags shall be attached to the penetrating item with permanent wire, string or plastic tie, within 6 inches (150 mm) of the assembly.

Reason:

Installing penetration firestop systems looks as easy as applying red caulk to an assembly. Firestop systems are not easy to install. Firestop systems are very complex, detailed listed systems that take understanding of the tolerances so they work when called upon by fire.

This proposal adds a requirement to identify the firestop system used to maintain fire-resistance at the assembly. This is a way for the special inspection agency inspector, during construction, and building owner and manager, during the life of the building, to understand quickly what listing has been used. The listing has the information needed to evaluate the installation and maintain compliance during construction and through the building life cycle. It's not read caulk that's been installed. It's an assemblage of materials designed to keep fire from spreading outside the room of origin. The identification device makes the verification process much more efficient and effective.

Cost Impact

The code change proposal will increase the cost of construction .

The cost of an identification device will add a very small amount to the cost of construction, but will decrease the cost of inspection and maintenance. The identification device cost per penetration firestop system is approximately \$0.10US per penetration.

Internal ID: 2330

FS47-18

IBC: 714.2.1 (NEW), 715.2.1(NEW)

Proponent: William Koffel, representing Firestop Contractors International Association (wkoffel@koffel.com)

2018 International Building Code

Add new text as follows:

714.2 Installation. A listed *penetration firestop* system shall be installed in accordance with the manufacturer's installation instructions and the listing criteria.

714.2.1 Contractor qualifications. In buildings that are 420 feet. (128 m) or greater in building height, penetration firestop systems shall be installed by contractors qualified by Underwriters Laboratories (UL), Factory Mutual (FM), or an approved agency.

Exceptions:

1. Where the work is of a minor nature as approved by the building official.
2. Where the work is a repair or Alteration Level 1 as defined by the International Existing Building Code.

715.2 Installation. A *fire-resistant joint system* shall be securely installed in accordance with the manufacturer's installation instructions and the listing criteria in or on the joint for its entire length so as not to impair its ability to accommodate expected building movements and to resist the passage of fire and hot gases.

715.2.1 Contractor qualifications. In buildings that are 420 feet (128 m) or greater in building height, fire-resistant joint systems shall be installed by contractors qualified by Underwriters Laboratories (UL), Factory Mutual (FM) or an approved agency.

Exceptions:

1. Where the work is of a minor nature as approved by the building official.
2. Where the work is a repair or Alteration Level 1 as defined by the International Existing Building Code.

Reason:

There currently is a big risk with penetration firestop systems not installed to the listing or manufacturer's installation instructions. Building survey findings have shown installation deficiencies demonstrating a lack of knowledge regarding penetration firestop systems, lack of knowledge of the complex listings, and lack of knowledge regarding manufacturer's instructions. Also, a risk exists with fire-resistive joint systems not installed to the listing or the manufacturers installation instructions. Building survey findings identify installation deficiencies showing a lack of listing knowledge for these complex assemblies.

Requirements that penetration firestop systems and fire-resistive joint systems be installed by a FM 4991 Approved or UL Qualified Firestop Contractor means 3rd party exam and audit proven knowledge and processes exist to follow listings and manufacturers instructions. The FM 4991, Standard for the Approval of Firestop Contractors and UL Qualified Firestop Contractor Programs are similar to fabricator approval process in 1704.2.5.1 and manufacturers ISO 9000 quality management systems programs, but customized for the construction environment. The programs are administered by FM Approvals and UL, both independent of the Firestop Contractors International Association (FCIA) or firestop manufacturers, and the Contractors being audited. The programs verify that procedures for worker training, installation, review of installation, documentation or inventory of systems, and more, comply with program requirements and the contractor's quality management system procedures. A designated responsible individual implements the program at the firestop contractor company.

The initial cost to become FM 4991 Approved or UL Qualified ranges from \$7000 to \$12,000. An annual audit is required by the UL and FM programs which costs about \$3,500. The contractor company spreads these costs amongst all their projects, meaning a small cost of doing business. Efficiencies gained from quality processes help offset the costs.

The current FM 4991 or UL Qualified Contractor list mirrors where these tall buildings are located. The contractors travel a region increasing availability providing competitive bidding to building owners and managers. Whereas it will be several years before this requirement would be in effect, there is plenty of time for other contractors to participate in the FM or UL programs.

Cost Impact

The code change proposal will not increase or decrease the cost of construction .

The firestop contractor that understands systems selection, analysis, the listings and manufacturers installation instructions gets the penetration firestop systems installed correctly the first time. The firestop contractor that does not know the industry protocol and installs 'fire caulk' and not systems is not providing the work result demanded by the code and will be non compliant. There are enough FM 4991 Approved and UL Qualified Firestop Contractors to provide a competitive environment for the general contractor and building owner and manager, and, should this be mandated, many more will appear.

Internal ID: 2243

FS48-18

IBC: 714.4.2

Proponent: Homer Maiel, representing ICC Tri-Chapter (Peninsula, East Bay, Monterey Bay) (hmaiel@gmail.com)

2018 International Building Code

Revise as follows:

714.4.2 Membrane penetrations. *Membrane penetrations* shall comply with Section 714.4.1. Where walls or partitions are required to have a *fire-resistance rating*, recessed fixtures shall be installed such that the required *fire resistance* will not be reduced.

Exceptions:

1. *Membrane penetrations* of maximum 2-hour fire-resistance-rated walls and partitions by steel electrical boxes that do not exceed 16 square inches (0.0103 m²) in area, provided that the aggregate area of the openings through the membrane does not exceed 100 square inches (0.0645 m²) in any 100 square feet (9.29 m²) of wall area. The *annular space* between the wall membrane and the box shall not exceed 1/8 inch (3.2 mm). Such boxes on opposite sides of the wall or partition shall be separated by one of the following:
 - 1.1. By a horizontal distance of not less than 24 inches (610 mm) where the wall or partition is constructed with individual noncommunicating stud cavities.
 - 1.2. By a horizontal distance of not less than the depth of the wall cavity where the wall cavity is filled with cellulose loose-fill, rockwool or slag *mineral wool* insulation.
 - 1.3. By solid *fireblocking* in accordance with Section 718.2.1.
 - 1.4. By protecting both outlet boxes with *listed* putty pads.
 - 1.5. By other *listed* materials and methods.
2. *Membrane penetrations* by *listed* electrical boxes of any material, provided that such boxes have been tested for use in fire-resistance-rated assemblies and are installed in accordance with the instructions included in the listing. The *annular space* between the wall membrane and the box shall not exceed 1/8 inch (3.2 mm) unless *listed* otherwise. Such boxes on opposite sides of the wall or partition shall be separated by one of the following:
 - 2.1. By the horizontal distance specified in the listing of the electrical boxes.
 - 2.2. By solid *fireblocking* in accordance with Section 718.2.1.
 - 2.3. By protecting both boxes with *listed* putty pads.
 - 2.4. By other *listed* materials and methods.
3. *Membrane penetrations* by electrical boxes of any size or type, that have been *listed* as part of a wall opening protective material system for use in fire-resistance-rated assemblies and are installed in accordance with the instructions included in the listing.
4. *Membrane penetrations* by boxes other than electrical boxes, provided that such penetrating items and the *annular space* between the wall membrane and the box, are protected by an *approved membrane penetration firestop system* installed as tested in accordance with ASTM E814 or UL 1479, with a minimum positive pressure differential of 0.01 inch (2.49 Pa) of water, and shall have an F and T rating of not less than the required *fire-resistance rating* of the wall penetrated and be installed in accordance with their listing.
5. The *annular space* created by the penetration of an automatic sprinkler, provided that it is covered by a metal escutcheon plate.
6. *Membrane penetrations* of maximum 2-hour fire-resistance-rated walls and partitions by steel electrical boxes that exceed 16 square inches (0.0103 m²) in area, or steel electrical boxes of any size having an aggregate area through the membrane exceeding 100 square inches (0.0645 m²) in any 100 square feet (9.29 m²) of wall area, provided that such penetrating items are protected by *listed* putty pads or other *listed* materials and methods, and installed in accordance with the listing.
7. The wall membrane of 1- or 2-hour fire-resistance-rated wall assemblies is permitted to be interrupted with a double wood end stud at the intersection of light frame wood wall assemblies provided: the intersecting wall has a membrane of 5/8 inch Type X gypsum, all penetrating items

through the double wood stud are protected in accordance with Section 714.4.1.1 or 714.4.1.2, and the interrupted membrane is tight to the double wood stud. The cavity of the 1- or 2- hour fire-resistance-rated wall assembly shall be blocked solid with material suitable as a fire block in Section 718.2 if the wall membrane is interrupted on both sides of the wall within a single stud space.

Reason:

This proposal provides an exception for wall assemblies similar to exception 7 currently in Section 714.5.2 for membrane penetrations of a horizontal assembly. Additional material suitable as a fire block is added to the wall cavity if a similar condition occurs on both sides of the 1- or 2- hour rated wall into the same stud cavity. Double studs at the intersection have an intrinsic fire resistance rating greater than the layer of 5/8" gypsum board and is suitable in this wall application similar to the horizontal assembly found in section 714.5.2.

Cost Impact

The code change proposal will increase the cost of construction .

This proposal is merely guiding the user as to how to treat the intersection of two fire rated walls. In the absence of any current guidelines, this could potentially increase the cost of construction

Internal ID: 2095

FS49-18

IBC: 714.4.3, 714.5.3

Proponent: Lee Kranz, City of Bellevue, WA, representing Washington Association of Building Officials Technical Code Development Committee (lkranz@bellevuewa.gov)

2018 International Building Code

Revise as follows:

714.4.3 Dissimilar materials. Noncombustible penetrating items shall not connect to combustible items beyond the point of firestopping unless it can be demonstrated that the *fire-resistance* integrity of the wall is maintained.

Exceptions:

1. Where dissimilar materials are used and the portion of the penetrating material extending into or through the fire-resistance rated assembly is combustible, the combustible material shall extend not less than 6 inches past both sides of the approved penetration firestop system before transitioning to non-combustible materials. The 6 inches shall be measured as the developed length and shall be continuous through all fittings and transitions.
2. Where dissimilar materials are used and the portion of the penetrating material extending into or through the fire-resistance rated assembly is non-combustible, the non-combustible material shall extend not less than 36 inches past both sides of the approved penetration firestop system before transitioning to combustible materials. The 36 inches shall be measured as the developed length and shall be continuous through all fittings and transitions.

714.5.3 Dissimilar materials. Noncombustible penetrating items shall not connect to combustible materials beyond the point of firestopping unless it can be demonstrated that the *fire-resistance* integrity of the *horizontal assembly* is maintained.

Exceptions:

1. Where dissimilar materials are used and the portion of the penetrating material extending into or through the fire-resistance rated assembly is combustible, the combustible material shall extend not less than 6 inches past both sides of the approved penetration firestop system before transitioning to non-combustible materials. The 6 inches shall be measured as the developed length and shall be continuous through all fittings and transitions.
2. Where dissimilar materials are used and the portion of the penetrating material extending into or through the fire-resistance rated assembly is non-combustible, the non-combustible material shall extend not less than 36 inches past both sides of the approved penetration firestop system before transitioning to combustible materials. The 36 inches shall be measured as the developed length and shall be continuous through all fittings and transitions.

Reason:

Many plumbing system installations involve the combined use of combustible and noncombustible piping, drains, waste and vents. For example, cast iron (noncombustible) drains may be used for sound control but plastic (combustible) vents are combined on each story for cost savings. The reason for these designs is understandable but the integrity of fire-resistive rated construction may be compromised as a result of mixing these materials. The 6" and 36" dimensions are drawn from Section 8.3.5.5 of the 2015 edition of NFPA 101, which provides a method that maintains the integrity of the fire-resistive rated assembly as reflected in this proposal. This code change will also reduce delays and the cost of construction by eliminating the need for testing.

8.3.5.5 Transitions.

8.3.5.5.1

Where piping penetrates a fire resistance-rated wall or floor assembly, combustible piping shall not connect to noncombustible piping within 36 in. (915 mm) of the firestop system or device without demonstration that the transition will not reduce the fire resistance rating, except in the case of previously approved installations.

8.3.5.5.2

Unshielded couplings shall not be used to connect noncombustible piping to combustible piping unless it can be demonstrated that the transition complies with the fire-resistive requirements of 8.3.5.1.

Dissimilar Materials Penetrating a Rated Assembly
IBC 714.3.3 & 714.4.3 and NFPA 101 8.3.5.5

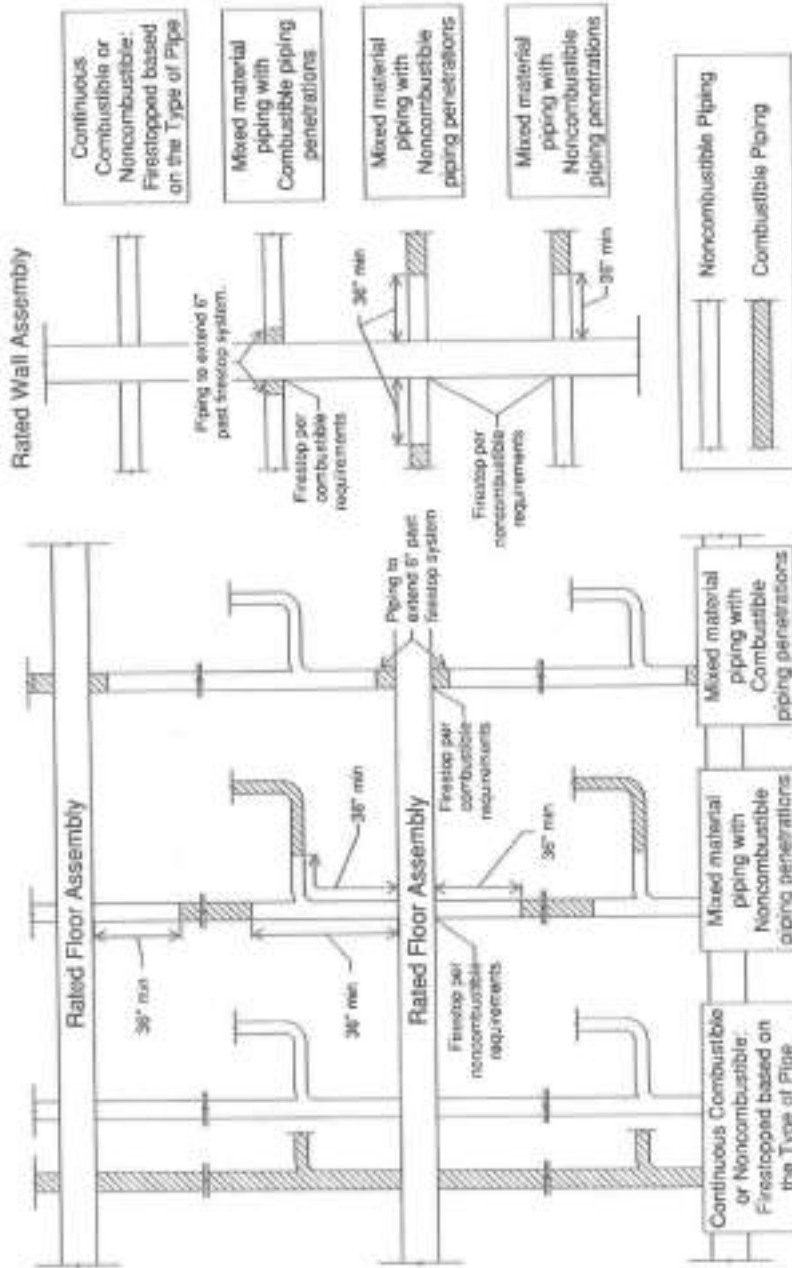

Bibliography:

2015 Edition of NFPA 101, Section 8.3.5.1 and 8.3.5.2.

Cost Impact

The code change proposal will decrease the cost of construction .

This code change will reduce the cost of construction by eliminating the need for testing.

Internal ID: 97

FS50-18

IBC: 714.5.2

Proponent: Michael O'Brian, Chair, representing FCAC (fcac@iccsafe.org)

2018 International Building Code

Revise as follows:

714.5.2 Membrane penetrations. Penetrations of membranes that are part of a *horizontal assembly* shall comply with Section 714.5.1.1 or 714.5.1.2. Where floor/ceiling assemblies are required to have a *fire-resistance rating*, recessed fixtures shall be installed such that the required *fire resistance* will not be reduced.

Exceptions:

1. *Membrane penetrations* by steel, ferrous or copper conduits, pipes, tubes or vents, or concrete or masonry items where the *annular space* is protected either in accordance with Section 714.5.1 or to prevent the free passage of flame and the products of combustion. The aggregate area of the openings through the membrane shall not exceed 100 square inches (64 500 mm²) in any 100 square feet (9.3 m²) of ceiling area in assemblies tested without penetrations.
2. Ceiling *membrane penetrations* of maximum 2-hour *horizontal assemblies* by steel electrical boxes that do not exceed 16 square inches (10 323 mm²) in area, provided that the aggregate area of such penetrations does not exceed 100 square inches (44 500 mm²) in any 100 square feet (9.29 m²) of ceiling area, and the *annular space* between the ceiling membrane and the box does not exceed 1/8 inch (3.2 mm).
3. *Membrane penetrations* by electrical boxes of any size or type, that have been *listed* as part of an opening protective material system for use in *horizontal assemblies* and are installed in accordance with the instructions included in the listing.
4. *Membrane penetrations* by *listed* electrical boxes of any material, provided that such boxes have been tested for use in fire-resistance-rated assemblies and are installed in accordance with the instructions included in the listing. The *annular space* between the ceiling membrane and the box shall not exceed 1/8 inch (3.2 mm) unless *listed* otherwise.
5. The *annular space* created by the penetration of a fire sprinkler, provided that it is covered by a metal escutcheon plate.
6. Noncombustible items that are cast into concrete building elements and that do not penetrate both top and bottom surfaces of the element.
7. The ceiling membrane of ~~1- and a~~ maximum 2-hour fire-resistance-rated *horizontal assemblies* is permitted to be interrupted with the double wood top plate of a wall assembly that is sheathed with Type X gypsum wallboard, provided that all penetrating items through the double top plates are protected in accordance with Section 714.5.1.1 or 714.5.1.2 and the ceiling membrane is tight to the top plates.
8. Ceiling membrane penetrations by listed luminaires (light fixtures) or by luminaires protected with listed materials, which have been tested for use in fire-resistance-rated assemblies and are installed in accordance with the instructions included in the listing.

Reason:

Section 714.5.2, Exception 7, relates to the double wood top plate exception, and the language currently applies only to 1- and 2- hour fire-resistance-rated horizontal assemblies. However, there are cases where the fire-resistance rating of the horizontal assembly may be 90 minutes, 45 minutes or 30 minutes.

This proposal clarifies the exception, but does not change the intent of the original IBC requirement.

This proposal is submitted by the ICC Fire Code Action Committee (FCAC). The FCAC was established by the ICC Board of Directors to pursue opportunities to improve and enhance assigned International Codes with regard to fire safety and hazardous materials in new and existing buildings and facilities and the protection of life and property in wildland urban interface areas. In 2017 the Fire-CAC has held 3 open meetings. In addition, there were numerous conference calls, Regional Work Group and Task Group meetings for the current code development cycle, which included members of the committees as well as any interested parties, to discuss and debate the proposed changes. Related documentation and reports are posted on the FCAC website at: <https://www.iccsafe.org/codes-tech-support/cs/fire-code-action-committee-fcac/>

Cost Impact

The code change proposal will not increase or decrease the cost of construction .

This proposal simply clarifies the original intent of the exception. It does not add new construction requirements.

Internal ID: 319

FS51-18

IBC: 712.1.5.2, 715.1 (New), 715.3, , 715.3.1, 715.5, 715.6, 715.7, 715.8

Proponent: Michael O'Brian, Chair, representing FCAC (fcac@iccsafe.org)

2018 International Building Code

Revise as follows:

712.1.5.2 Joints in or between nonfire-resistance-rated floor assemblies. Joints in or between floor assemblies without a required *fire-resistance rating* shall be permitted where they comply with one of the following:

1. The joint shall be concealed within the cavity of a wall.
2. The joint shall be located above a ceiling.
3. The joint shall be sealed, treated or covered with an *approved* material or system to resist the free passage of flame and the products of combustion.

Exception: Joints meeting one of the exceptions listed in Section ~~715.1~~715.3.

Add new text as follows:

715.1 General. The provision of this section shall govern the materials and methods of construction used to protect joints and voids in or between horizontal and vertical assemblies.

Revise as follows:

~~715.1-715.3 General.~~ **Fire-resistance-rated assembly intersections.** Joints installed in or between fire-resistance-rated walls, floor or floor/ceiling assemblies and roofs or roof/ceiling assemblies shall be protected by an approved *fire-resistant joint* system designed to resist the passage of fire for a time period not less than the required *fire-resistance rating* of the wall, floor or roof in or between which the system is installed. ~~Fire-resistant joint systems shall be tested in accordance with Section 715.3.~~

Exception: *Fire-resistant joint systems* shall not be required for joints in all of the following locations:

1. Floors within a single *dwelling unit*.
2. Floors where the joint is protected by a shaft enclosure in accordance with Section 713.
3. Floors within atriums where the space adjacent to the atrium is included in the volume of the atrium for smoke control purposes.
4. Floors within malls.
5. Floors and ramps within parking garages or structures constructed in accordance with Sections 406.5 and 406.6.
6. Mezzanine floors.
7. Walls that are permitted to have unprotected openings.
8. Roofs where openings are permitted.
9. Control joints not exceeding a maximum width of 0.625 inch (15.9 mm) and tested in accordance with ASTM E119 or UL 263.
10. The intersection of exterior curtain wall assemblies and the roof slab or roof deck.

Delete without substitution:

~~715.1.1 Curtain wall assembly.~~ The void created at the intersection of a floor/ceiling assembly and an exterior curtain wall assembly shall be protected in accordance with Section 715.4.

Revise as follows:

~~715.3-715.3.1~~ **Fire test criteria.** *Fire-resistant joint systems* shall be tested in accordance with the requirements of either ASTM E1966 or UL 2079. Nonsymmetrical wall joint systems shall be tested with both faces exposed to the furnace, and the assigned *fire-resistance rating* shall be the shortest duration obtained from the two tests. Where

evidence is furnished to show that the wall was tested with the least fire-resistant side exposed to the furnace, subject to acceptance of the *building official*, the wall need not be subjected to tests from the opposite side.

Exception: For *exterior walls* with a horizontal *fire separation distance* greater than 10 feet (3048 mm), the joint system shall be required to be tested for interior fire exposure only.

715.4.1-715.5 Exterior curtain wall/nonfire-resistance-rated floor assembly intersections. Voids created at the intersection of exterior curtain wall assemblies and nonfire-resistance-rated floor or floor/ceiling assemblies shall be sealed with an *approved* material or system to retard the interior spread of fire and hot gases between *stories*.

715.4.2-715.6 Exterior curtain wall/vertical fire barrier intersections. Voids created at the intersection of nonfire-resistance-rated exterior curtain wall assemblies and *fire barriers* shall be filled. An approved material or system shall be used to fill the void and shall be securely installed in or on the intersection for its entire length so as not to dislodge, loosen or otherwise impair its ability to accommodate expected building movements and to retard the passage of fire and hot gases.

715.5-715.7 Spandrel wall. Height and *fire-resistance* requirements for curtain wall spandrels shall comply with Section 705.8.5. Where Section 705.8.5 does not require a fire-resistance-rated spandrel wall, the requirements of Section 715.4 shall still apply to the intersection between the spandrel wall and the floor.

715.6-715.8 Fire-resistant joint systems in smoke barriers. *Fire-resistant joint systems* in *smoke barriers*, and joints at the intersection of a horizontal *smoke barrier* and an exterior curtain wall, shall be tested in accordance with the requirements of UL 2079 for air leakage. The L rating of the joint system shall not exceed 5 cfm per linear foot (0.00775 m³/s m) of joint at 0.30 inch (7.47 Pa) of water for both the ambient temperature and elevated temperature tests.

Reason:

This proposal is submitted by the ICC Fire Code Action Committee (FCAC). The FCAC was established by the ICC Board of Directors to pursue opportunities to improve and enhance assigned International Codes with regard to fire safety and hazardous materials in new and existing buildings and facilities and the protection of life and property in wildland urban interface areas. In 2017 the Fire-CAC has held 3 open meetings. In addition, there were numerous conference calls, Regional Work Group and Task Group meetings for the current code development cycle, which included members of the committees as well as any interested parties, to discuss and debate the proposed changes. Related documentation and reports are posted on the FCAC website at: [https://www.iccsafe.org/codes-tech-support/cs/fire-code-action-committee-fcac/Section 715](https://www.iccsafe.org/codes-tech-support/cs/fire-code-action-committee-fcac/Section%20715) is not organized in the best fashion, which has created problems in properly applying its requirements.

This proposal, developed by the FCAC Chapter 7 work group, clarifies the requirements without making any substantive changes. Clarification was provided primarily by rearranging requirements in a more logical order, revising titles of sections so they are more descriptive of the subject matter, and correcting cross references to the new section numbers. Additional revisions include:

- A new Section 715.1 was added with charging language similar to Section 714.1.
- The cross reference in new 715.3 was removed since the referenced section immediately follows at 715.3.1.
- The cross reference in former 715.1.1 was not needed and has been deleted.

This proposal will be accompanied by a series of technical proposals. The technical proposals will introduce new and revised terminology, new and revised definitions, and new and revised requirements which complement the new organization proposed here. Assuming this proposal and the series of technical proposals are all Approved as Submitted, the updated language would appear as follows in the 2021 IBC:

SECTION 202

DEFINITIONS

CONTINUITY HEAD-OF-WALL JOINT SYSTEM. An assemblage of specific materials or products that are designed to resist the passage of fire through voids created at the intersection of fire barriers and the underside of nonfire-resistance-rated roofs and floors for a prescribed period of time.

F RATING. The time period that the through-penetration firestop system, perimeter fire barrier or continuity head-of-wall joint system limits the spread of fire through the penetration or void.

T RATING. The time period that the penetration firestop system, including the penetrating item, or the continuity head-

of-wall joint system limits the maximum temperature rise to 325°F (180°C) above its initial temperature through the penetration or void on the nonfire side.

PERIMETER FIRE BARRIER. An assemblage of specific materials or products that are designed to resist for a prescribed period of time the passage of fire through voids created at the intersection of exterior curtain wall assemblies and fire-resistance-rated floor or floor/ceiling assemblies.

SECTION 707 FIRE BARRIERS

707.8 Joints and voids. The following joints and voids shall be protected in accordance with Section 715:

1. Joints in or between fire barriers.
2. Joints between fire barriers and fire-resistance-rated wall assemblies.
3. Joints between fire barriers and the underside of fire-resistance-rated floor or floor/ceiling assemblies.
4. Joints between fire barriers and the underside of fire-resistance-rated roofs or roof/ceiling assemblies.
5. Voids at the intersection of fire barriers and nonfire-resistance-rated exterior curtain wall assemblies.
6. Voids between fire barriers and the underside of nonfire-resistance-rated roofs or roof/ceiling assemblies.
7. Voids between fire barriers and the underside of nonfire-resistance-rated floors or floor/ceiling assemblies.

Delete current Section 707.9.

SECTION 712 VERTICAL OPENINGS

712.1.5.2 Joints in or between nonfire-resistance-rated floor assemblies. Joints in or between floor assemblies without a required fire-resistance rating shall be permitted where they comply with one of the following:

1. The joint shall be concealed within the cavity of a wall.
2. The joint shall be located above a ceiling.
3. The joint shall be sealed, treated or covered with an approved material or system to resist the free passage of flame and the products of combustion.

Exception: Joints meeting one of the exceptions listed in Section 715.3.

SECTION 715 JOINTS AND VOIDS

715.1 General. The provision of this section shall govern the materials and methods of construction used to protect joints and voids in or between horizontal and vertical assemblies.

715.2 Installation. Systems or materials protecting joints and voids shall be securely installed in accordance with the manufacturer's installation instructions in or on the joint or void for its entire length so as not to dislodge, loosen or otherwise impair its ability to accommodate expected building movements and to resist the passage of fire and hot gases. Fire-resistant joint systems, perimeter fire barriers and continuity head-of-wall joint systems shall also be installed in accordance with the listing criteria.

715.3 Fire-resistance-rated assembly intersections. Joints installed in or between fire-resistance-rated walls, floor or floor/ceiling assemblies and roofs or roof/ceiling assemblies shall be protected by an approved fire-resistant joint system designed to resist the passage of fire for a time period not less than the required fire-resistance rating of the wall, floor or roof in or between which the system is installed.

Exception: Fire-resistant joint systems shall not be required for joints in all of the following locations:

1. Floors within a single dwelling unit.
2. Floors where the joint is protected by a shaft enclosure in accordance with Section 713.
3. Floors within atriums where the space adjacent to the atrium is included in the volume of the atrium for smoke control purposes.
4. Floors within malls.
5. Floors and ramps within parking garages or structures constructed in accordance with Sections 406.5 and 406.6.
6. Mezzanine floors.
7. Walls that are permitted to have unprotected openings.

8. Roofs where openings are permitted.

9. Control joints not exceeding a maximum width of 0.625 inch (15.9 mm) and tested in accordance with ASTM E 119 or UL 263.

10. The intersection of exterior curtain wall assemblies and the roof slab or roof deck.

715.3.1 Fire test criteria. Fire-resistant joint systems shall be tested in accordance with the requirements of either ASTM E1966 or UL 2079. Nonsymmetrical wall joint systems shall be tested with both faces exposed to the furnace, and the assigned fire-resistance rating shall be the shortest duration obtained from the two tests. Where evidence is furnished to show that the wall was tested with the least fire-resistant side exposed to the furnace, subject to acceptance of the building official, the wall need not be subjected to tests from the opposite side.

Exception: For exterior walls with a horizontal fire separation distance greater than 10 feet (3048 mm), the joint system shall be required to be tested for interior fire exposure only.

715.4 Exterior curtain wall/fire-resistance-rated floor intersections. Voids created at the intersection of exterior curtain wall assemblies and fire-resistance-rated floor or floor/ceiling assemblies shall be protected with an approved perimeter fire barrier to prevent the interior spread of fire. Such systems shall provide an F rating for a time period not less than the fire-resistance rating of the floor or floor/ceiling assembly.

715.4.1 Fire test criteria. Perimeter fire barriers shall be tested in accordance with the requirements of ASTM E2307.

Exception: Voids created at the intersection of the exterior curtain wall assemblies and such floor assemblies where the vision glass extends to the finished floor level shall be permitted to be protected with an approved material to prevent the interior spread of fire. Such material shall be securely installed and capable of preventing the passage of flame and hot gases sufficient to ignite cotton waste where subjected to ASTM E119 time-temperature fire conditions under a minimum positive pressure differential of 0.01 inch (0.254 mm) of water column (2.5 Pa) for the time period not less than the fire-resistance rating of the floor assembly.

715.5 Exterior curtain wall/nonfire-resistance-rated floor assembly intersections. Voids created at the intersection of exterior curtain wall assemblies and nonfire-resistance-rated floor or floor/ceiling assemblies shall be filled with an approved material or system to retard the interior spread of fire and hot gases between stories.

715.6 Exterior curtain wall/vertical fire barrier intersections. Voids created at the intersection of nonfire-resistance-rated exterior curtain wall assemblies and vertical fire barriers shall be filled with an approved material or system to retard the interior spread of fire and hot gases.

715.7 Voids at intersections of fire barriers and underside of nonfire-resistance-rated roofs and floors. The voids created at the intersection of a fire barrier and the underside of a nonfire-resistance-rated roof or floor sheathing, slab or deck above shall be protected by an approved continuity head-of-wall joint system installed as tested in accordance with ASTM E2837 to provide an F rating/T rating for a time period not less than the required fire-resistance rating of the wall assembly in which it is installed or be filled with an approved material or system. Such materials or systems shall be securely installed in accordance with the manufacturer's installation instructions in or on the void for its entire length so as not to dislodge, loosen or otherwise impair its ability to accommodate expected building movements and to resist the passage of fire and hot gases. Continuity head-of-wall joint systems shall also be installed in accordance with the listing criteria.

715.8 Curtain wall spandrels. Height and fire-resistance requirements for curtain wall spandrels shall comply with Section 705.8.5. Where Section 705.8.5 does not require a fire-resistance-rated spandrel wall, the requirements of Sections 715.4 and 715.5 shall still apply to the intersection between the spandrel wall and the floor.

715.9 Joints and voids in smoke barriers. Fire-resistant joint systems protecting joints in smoke barriers, and perimeter fire barriers protecting voids at the intersection of a horizontal smoke barrier and an exterior curtain wall, shall be tested in accordance with the requirements of UL 2079 for air leakage. The L rating of the joint system shall not exceed 5 cfm per linear foot (0.00775 m³/s m) of joint at 0.30 inch (74.7 Pa) of water for both the ambient temperature and elevated temperature tests.

CHAPTER 35

REFERENCED STANDARDS

ASTM E2837-17 Standard Test Method for Determining the Fire Resistance of Continuity Head-of-Wall Joint Systems Installed Between Rated Wall Assemblies and Nonrated Horizontal Assemblies

Cost Impact

The code change proposal will not increase or decrease the cost of construction .

This proposal simply reorganizes the current requirements for protecting joints and voids.

FS52-18

IBC: 715.2, 715.4.2

Proponent: Michael O'Brian, Chair, representing FCAC (fcac@iccsafe.org)

2018 International Building Code

Revise as follows:

715.2 Installation. ~~A fire-resistant joint system~~ Systems or materials protecting joints and voids shall be securely installed in accordance with the manufacturer's installation instructions and the listing criteria in or on the joint or void for its entire length so as not to dislodge, loosen or otherwise impair its ability to accommodate expected building movements and to resist the passage of fire and hot gases. Fire-resistant joint systems or systems used to protect voids at exterior curtain walls and fire-resistance-rated floor intersections shall also be installed in accordance with the listing criteria.

715.4.2 Exterior curtain wall/vertical fire barrier intersections. Voids created at the intersection of nonfire-resistance-rated exterior curtain wall assemblies and vertical fire barriers shall be filled. ~~An filled with an approved material or system shall be used to fill the void and shall be securely installed in or on the intersection for its entire length so as not to dislodge, loosen or otherwise impair its ability to accommodate expected building movements and to retard the passage interior spread of fire and hot gases.~~

Reason:

Section 715.2 of the 2018 IBC covering installation is incomplete as written. It currently covers only fire-resistant joint systems. The installation requirements relating to the protection of the other types of and voids covered in Section 715 are inconsistently covered where the protection method is described. This proposal clarifies the installation requirements for all types of protection for joints and voids. Where the protection method is required to be tested to a specific test standard, the language proposed follows what is currently specified in the 2018 IBC for this situation. Where the code only requires the void to be filled, there are no listing requirements to describe the installation of a material or system.

The revisions to Section 715.4.2 serve three purposes as follows:

- Remove the installation details which are now contained in the revised Section 715.2.
- Add the word vertical in the body to be consistent with the title.
- Add the path of fire propagation covered by this provision in a similar manner to the way the path is described for the other types of voids.

The proposal compliments a proposal which reorganizes Section 715.

This proposal is submitted by the ICC Fire Code Action Committee (FCAC). The FCAC was established by the ICC Board of Directors to pursue opportunities to improve and enhance assigned International Codes with regard to fire safety and hazardous materials in new and existing buildings and facilities and the protection of life and property in wildland urban interface areas. In 2017 the Fire-CAC has held 3 open meetings. In addition, there were numerous conference calls, Regional Work Group and Task Group meetings for the current code development cycle, which included members of the committees as well as any interested parties, to discuss and debate the proposed changes. Related documentation and reports are posted on the FCAC website at: <https://www.iccsafe.org/codes-tech-support/cs/fire-code-action-committee-fcac/>

Cost Impact

The code change proposal will not increase or decrease the cost of construction .

All changes are editorial in nature and as such will not change construction practices.

Internal ID: 327

FS53-18

IBC: 202 (New), 202, 715.4, 715.4.1 (New), 715.5, 715.6, 715.7, 715.8, 1705.17

Proponent: Michael O'Brian, Chair, representing FCAC (fcac@iccsafe.org)

2018 International Building Code

SECTION 202 DEFINITIONS

Add new definition as follows:

PERIMETER FIRE CONTAINMENT SYSTEM. An assemblage of specific materials or products that are designed to resist for a prescribed period of time the passage of fire through voids created at the intersection of exterior curtain wall assemblies and fire-resistance-rated floor or floor/ceiling assemblies.

Revise as follows:

[BF] F RATING. The time period that the through-penetration firestop system or perimeter fire containment system limits the spread of fire through the penetration when tested in accordance with ASTM E814 or UL 1479 or void.

715.4 Exterior curtain wall/fire-resistance-rated floor intersection/intersections. ~~Where fire-resistance-rated floor or floor/ceiling assemblies are required, voids~~ Voids created at the intersection of the exterior curtain wall assemblies and ~~such floor fire-resistance-rated floor or floor/ceiling assemblies shall be sealed~~ protected with an ~~approved~~ perimeter fire containment system to prevent the interior spread of fire. Such systems shall ~~be securely installed and tested in accordance with ASTM E2307 to provide an F rating for a time period not less than the fire-resistance rating of the floor or floor/ceiling assembly.~~ Height and *fire-resistance* requirements for curtain wall spandrels shall comply with Section ~~705.8.5.~~ **Exception:** ~~Voids created at the intersection of the exterior curtain wall assemblies and such floor assemblies where the vision glass extends to the finished floor level shall be permitted to be sealed with an approved material to prevent the interior spread of fire. Such material shall be securely installed and capable of preventing the passage of flame and hot gases sufficient to ignite cotton waste where subjected to ASTM E119 time-temperature fire conditions under a minimum positive pressure differential of 0.01 inch (0.254 mm) of water column (2.5 Pa) for the time period not less than the fire-resistance rating of the floor assembly.~~ 705.8.5.

Add new text as follows:

715.4.1 Fire test criteria. Perimeter fire barriers shall be tested in accordance with the requirements of ASTM E2307.

Exception: Voids created at the intersection of the exterior curtain wall assemblies and floor assemblies where the vision glass extends to the finished floor level shall be permitted to be protected with an approved material to prevent the interior spread of fire. Such material shall be securely installed and capable of preventing the passage of flame and hot gases sufficient to ignite cotton waste where subjected to ASTM E119 time-temperature fire conditions under a minimum positive pressure differential of 0.01 inch (0.254 mm) of water column (2.5 Pa) for the time period not less than the fire-resistance rating of the floor assembly.

Revise as follows:

715.4.1-715.5 Exterior curtain wall/nonfire-resistance-rated floor assembly intersections. Voids created at the intersection of exterior curtain wall assemblies and nonfire-resistance-rated floor or floor/ceiling assemblies shall be ~~sealed~~ filled with an *approved* material or system to retard the interior spread of fire and hot gases between *stories*.

715.4.2-715.6 Exterior curtain wall/vertical fire barrier intersections. Voids created at the intersection of nonfire-resistance-rated exterior curtain wall assemblies and vertical fire barriers shall be filled. An approved material or system shall be used to fill the void and shall be securely installed in or on the intersection for its entire length so as not to dislodge, loosen or otherwise impair its ability to accommodate expected building movements and to retard the passage of fire and hot gases.

715.5-715.7 Spandrel wall. Height and *fire-resistance* requirements for curtain wall spandrels shall comply with Section 705.8.5. Where Section 705.8.5 does not require a fire-resistance-rated spandrel wall, the requirements of Section 715.4 shall still apply to the intersection between the spandrel wall and the floor.

715.6-715.8 Fire-resistant joint systems-joints and voids in smoke barriers. *Fire-resistant joint systems protecting joints* in *smoke barriers*, and ~~joints-perimeter fire containment systems protecting voids~~ at the intersection of a horizontal *smoke barrier* and an exterior curtain wall, shall be tested in accordance with the requirements of UL 2079 for air leakage. The L rating of the joint system shall not exceed 5 cfm per linear foot (0.00775 m³/s m) of joint at 0.30 inch (~~7.47-74.7~~ Pa) of water for both the ambient temperature and elevated temperature tests.

[BF] 1705.17 Fire-resistant penetrations and joints. In high-rise buildings or in buildings assigned to *Risk Category III* or *IV*, *special inspections* for *through-penetrations*, membrane penetration firestops, *fire-resistant joint systems* and perimeter fire ~~barrier-containment~~ systems that are tested and *listed* in accordance with Sections 714.4.1.2, 714.5.1.2, 715.3 and 715.4 shall be in accordance with Section 1705.17.1 or 1705.17.2.

Reason:

The primary intent of this proposal is to introduce the phrase “Perimeter Fire Containment Systemr” to describe the method of protecting the void at the intersection of an exterior curtain wall assembly and a fire-resistance-rated floor or floor/ceiling assembly. Having such a phrase simplifies the code language by having a short and concise phrase to describe such intersections. This proposal also creates consistency with other provisions of Section 715 which states voids which are not required to be tested to any particular fire test standards are to be “filled”, and joints and voids which are required to be tested to a specific standard are to be “protected”. The revisions to Section 715.8 are intended to update the section heading to include both types of joints and voids referenced in the body of the Section and include the new language perimeter fire barrier.

The proposal compliments a proposal which reorganizes Section 715.

This proposal is submitted by the ICC Fire Code Action Committee (FCAC). The FCAC was established by the ICC Board of Directors to pursue opportunities to improve and enhance assigned International Codes with regard to fire safety and hazardous materials in new and existing buildings and facilities and the protection of life and property in wildland urban interface areas. In 2017 the Fire-CAC has held 3 open meetings. In addition, there were numerous conference calls, Regional Work Group and Task Group meetings for the current code development cycle, which included members of the committees as well as any interested parties, to discuss and debate the proposed changes. Related documentation and reports are posted on the FCAC website at: <https://www.iccsafe.org/codes-tech-support/cs/fire-code-action-committee-fcac/>

Cost Impact

The code change proposal will not increase or decrease the cost of construction .

All changes are editorial in nature and as such will not change construction practices.

Internal ID: 325

FS54-18

IBC: 715.4, 715.5

Proponent: Michael O'Brian, Chair, representing FCAC (fcac@iccsafe.org)

2018 International Building Code

Revise as follows:

715.4 Exterior curtain wall/floor intersection. Where fire-resistance-rated floor or floor/ceiling assemblies are required, voids created at the intersection of the exterior curtain wall assemblies and such floor assemblies shall be sealed with an *approved* system to prevent the interior spread of fire. Such systems shall be securely installed and tested in accordance with ASTM E2307 to provide an *F rating* for a time period not less than the *fire-resistance rating* of the floor assembly. ~~Height and fire-resistance requirements for curtain wall spandrels shall comply with Section 705.8.5.~~

Exception: Voids created at the intersection of the exterior curtain wall assemblies and such floor assemblies where the vision glass extends to the finished floor level shall be permitted to be sealed with an approved material to prevent the interior spread of fire. Such material shall be securely installed and capable of preventing the passage of flame and hot gases sufficient to ignite cotton waste where subjected to ASTM E119 time-temperature fire conditions under a minimum positive pressure differential of 0.01 inch (0.254 mm) of water column (2.5 Pa) for the time period not less than the *fire-resistance rating* of the floor assembly.

715.5 Spandrel wall. ~~Curtain wall spandrels.~~ Height and *fire-resistance* requirements for curtain wall spandrels shall comply with Section 705.8.5. Where Section 705.8.5 does not require a fire-resistance-rated spandrel wall, the requirements of ~~Section~~ Sections 715.4 and 715.4.1 shall still apply to the intersection between the spandrel wall and the floor.

Reason:

This proposal accomplishes several goals. First, it deletes a redundant reference to Section 705.8.5 from Section 715.4. The same reference is also in Section 715.5 covering curtain wall spandrels. Second, it cleans up inconsistent references to the curtain wall spandrels between the title and the body of Section 715.5. Third, it clarifies that this requirement applies to both the void at the intersection of a fire-resistance-rated floor and the curtain wall, covered in Section 715.4, and the void at the intersection of a nonfire-resistance-rated floor and the curtain wall, covered in Section 715.4.1.

The proposal compliments a proposal which reorganizes Section 715.

This proposal is submitted by the ICC Fire Code Action Committee (FCAC). The FCAC was established by the ICC Board of Directors to pursue opportunities to improve and enhance assigned International Codes with regard to fire safety and hazardous materials in new and existing buildings and facilities and the protection of life and property in wildland urban interface areas. In 2017 the Fire-CAC has held 3 open meetings. In addition, there were numerous conference calls, Regional Work Group and Task Group meetings for the current code development cycle, which included members of the committees as well as any interested parties, to discuss and debate the proposed changes. Related documentation and reports are posted on the FCAC website at: <https://www.iccsafe.org/codes-tech-support/cs/fire-code-action-committee-fcac/>

Cost Impact

The code change proposal will not increase or decrease the cost of construction .

All changes are editorial in nature and as such will not change construction practices.

Internal ID: 329

FS55-18

IBC: 715.6

Proponent: Michael O'Brian, Chair, representing FCAC (fcac@iccsafe.org)

2018 International Building Code

Revise as follows:

715.6 Fire-resistant joint systems joints and voids in smoke barriers. *Fire-resistant joint systems protecting joints in smoke barriers, and joints-systems protecting voids at the intersection of a horizontal smoke barrier and an exterior curtain wall, shall be tested in accordance with the requirements of UL 2079 for air leakage. The L rating of the joint system shall not exceed 5 cfm per linear foot (0.00775 m³/s m) of joint at 0.30 inch (~~7.47~~74.7 Pa) of water for both the ambient temperature and elevated temperature tests.*

Reason:

The title of Section 715.6 as currently written only references the protection of one of the two types of joints and voids covered in the text of the Section. As such, this proposal expands on the title of the section to incorporate both types of joints and voids covered by the Section. In addition, the proposal 1) clarifies that it is the system protecting the joints and voids, not the joint or void itself which is being tested for an L rating, and 2) corrects the conversion from inches of water to Pa.

The proposal compliments a proposal which reorganizes Section 715.

This proposal is submitted by the ICC Fire Code Action Committee (FCAC). The FCAC was established by the ICC Board of Directors to pursue opportunities to improve and enhance assigned International Codes with regard to fire safety and hazardous materials in new and existing buildings and facilities and the protection of life and property in wildland urban interface areas. In 2017 the Fire-CAC has held 3 open meetings. In addition, there were numerous conference calls, Regional Work Group and Task Group meetings for the current code development cycle, which included members of the committees as well as any interested parties, to discuss and debate the proposed changes. Related documentation and reports are posted on the FCAC website at: <https://www.iccsafe.org/codes-tech-support/cs/fire-code-action-committee-fcac/>

Cost Impact

The code change proposal will not increase or decrease the cost of construction .

All changes are editorial in nature and as such will not change construction practices.

Internal ID: 328

FS56-18

IBC: TABLE 716.1(2)

Proponent: Kellie Saylor, OZ Architecture, representing Code Change Committee of Colorado Chapter of the International Code Council (ksaylor@ozarch.com)

2018 International Building Code

Revise as follows:

**TABLE 716.1(2)
OPENING FIRE PROTECTION ASSEMBLIES, RATINGS AND MARKINGS**

TYPE OF ASSEMBLY	REQUIRED WALL ASSEMBLY RATING (hours)	MINIMUM FIRE DOOR AND FIRE SHUTTER ASSEMBLY RATING (hours)	DOOR VISION PANEL SIZE ^a	FIRE-RATED GLAZING MARKING DOOR VISION PANEL ^{c, e}	MINIMUM SIDELIGHT/TRANSOM ASSEMBLY RATING (hours)		FIRE-RATED GLAZING MARKING SIDELIGHT/TRANSOM PANEL	
					Fire protection	Fire resistance	Fire protection	Fire resistance
Fire walls and fire barriers having a required fire-resistance rating greater than 1 hour	4	3	See Note b	D-H-W-240	Not Permitted	4	Not Permitted	W-240
	3	3a	See Note b	D-H-W-180	Not Permitted	3	Not Permitted	W-180
	2	1½	100 sq. in.	≤ 100 sq. in. = D-H-90 > 100 sq. in. = D-H-W-90	Not Permitted	2	Not Permitted	W-120
	1½	1½	100 sq. in.	≤ 100 sq. in. = D-H-90 > 100 sq. in. = D-H-W-90	Not Permitted	1½	Not Permitted	W-90
Enclosures for shafts, interior exit stairways and interior exit ramps	2	1½	100 sq. in. ^f	≤ 100 sq. in. = D-H-90 > 100 sq. in. = D-H-T-W-90	Not Permitted	2	Not Permitted	W-120
Horizontal exits in fire walls ¹	4	3	100 sq. in.	≤ 100 sq. in. = D-H-180 > 100 sq. in. = D-H-W-240	Not Permitted	4	Not Permitted	W-240
	3	3 ^g	100 sq. in.	≤ 100 sq. in. = D-H-180 > 100 sq. in. = D-H-W-180	Not Permitted	3	Not Permitted	W-180
Fire barriers having a required fire-resistance rating of 1 hour; enclosures for shafts, exit access stairways, exit access ramps, interior exit stairways and interior exit ramps, and exit passageway walls	1	1	100 sq. in.	≤ 100 sq. in. = D-H-60 > 100 sq. in. = D-H-T-W-50	Not Permitted	1	Not Permitted	W-60
					Fire protection			
Other fire barriers	1	¾	Maximum size tested	D-H	¾			D-H
Fire partitions: Corridor walls	1 0.5	¾ ^b 1/3 ^b	Maximum size tested Maximum size tested	D-20 D-20	¾ ^b 1/3			D-H-OH-45 D-H-OH-20
Other fire partitions ¹	1 0.5	¾ ^{1/3}	Maximum size tested Maximum size tested	D-H-45D-H-20	¾ ^{1/3}			D-H-45 D-H-20
Exterior walls	3	1½	100 sq. in. ^h	≤ 100 sq. in. = D-H-90 > 100 sq. in. = D-H-W-90	Not Permitted	3	Not Permitted	W-180
	2	1½	Maximum size tested	D-H-90 or D-H-W-90	1½	2	D-H-OH-90	W-120
	1	¾	Maximum size tested	D-H-45	¾			D-H-45
					Fire protection			
Smoke barriers	1	1/3	Maximum size tested	D-20	¾			D-H-OH-45

For SI: 1 square inch = 645.2 mm.

- a. Two doors, each with a fire protection rating of 1½ hours, installed on opposite sides of the same opening in a fire wall, shall be deemed equivalent in fire protection rating to one 3-hour fire door.
- b. Fire-resistance-rated glazing tested to ASTM E119 in accordance with Section 716.1.2.3 shall be permitted, in the maximum size tested.
- c. Under the column heading "Fire-rated glazing marking door vision panel," W refers to the fire-resistance rating of the glazing, not the frame.
- d. See Section 716.2.5.1.2.1.
- e. See Section 716.1.2.2.1 and Table 716.1(1) for additional permitted markings.
- f. Two doors installed on opposite sides of the same opening in a fire partition shall both comply with the requirements in Table 716.1(2).

Reason:

Two doors installed on opposite sides of the same opening in a fire partition are common in adjoining hotel rooms. Currently the code is silent on the requirements for this type of "communicating" door. NFPA 101 states that only one door must be rated at a guest-to-guest room opening and some AHJ's rely on this as an interpretation since the IBC is silent. However, if only one door were rated and it was open when a fire started then the fire partition separating the rooms would be compromised. This code change proposal adds a footnote to Table 716.1(2) to indicate that both doors must be rated when installed on opposite sides of the same opening. This footnote is applied in the table under the Type of Assembly column at the row for "Other fire partitions".

Cost Impact

The code change proposal will not increase or decrease the cost of construction .

The code change proposal will not increase or decrease the cost of construction. This code change proposal is only making a requirement more clear for a specific application. It is reasonable to assume that this is how the code is typically enforced for this application anyways so there will likely not be an increase or decrease in the cost of construction. .

Internal ID: 313

FS57-18

IBC: TABLE 716.1(2), 716.2.5.1.2.2

Proponent: Tom Zaremba, Roetzel & Andress, representing Glazing Industry Code Committee and Alliance of Fire Rated Glazing Manufacturers (tzaremba@ralaw.com)

2018 International Building Code

Revise as follows:

TABLE 716.1(2)

OPENING FIRE PROTECTION ASSEMBLIES, RATINGS AND MARKINGS

TYPE OF ASSEMBLY	REQUIRED WALL ASSEMBLY RATING (hours)	MINIMUM FIRE DOOR AND FIRE SHUTTER ASSEMBLY RATING (hours)	DOOR VISION PANEL SIZE ^b	FIRE-RATED GLAZING MARKING DOOR VISION PANEL ^{c, e}	MINIMUM SIDELIGHT/TRANSOM ASSEMBLY RATING (hours)		FIRE-RATED GLAZING MARKING SIDELIGHT/TRANSOM PANEL	
					Fire protection	Fire resistance	Fire protection	Fire resistance
Fire walls and fire barriers having a required fire-resistance rating greater than 1 hour	4	3	See Note-b 100 sq. in.	D-H-W-240	Not Permitted	4	Not Permitted	W-240
	3	3a	See Note-b 100 sq. in.	D-H-W-180	Not Permitted	3	Not Permitted	W-180
	2	1½	100 sq. in.	≤ 100 sq. in. = D-H-90 > 100 sq. in. = D-H-W-90	Not Permitted	2	Not Permitted	W-120
	1½	1½	100 sq. in.	≤ 100 sq. in. = D-H-90 > 100 sq. in. = D-H-W-90	Not Permitted	1½	Not Permitted	W-90
Enclosures for shafts, interior exit stairways and interior exit ramps.	2	1½	100 sq. in. ^c	≤ 100 sq. in. = D-H-90 > 100 sq. in. = D-H-T-W-90	Not Permitted	2	Not Permitted	W-120
Horizontal exits in fire walls ^d	4	3	100 sq. in.	≤ 100 sq. in. = D-H-180 > 100 sq. in. = D-H-W-240	Not Permitted	4	Not Permitted	W-240
	3	3 ^e	100 sq. in.	≤ 100 sq. in. = D-H-180 > 100 sq. in. = D-H-W-180	Not Permitted	3	Not Permitted	W-180
Fire barriers having a required fire-resistance rating of 1 hour: Enclosures for shafts, exit access stairways, exit access ramps, interior exit stairways and interior exit ramps; and exit passageway walls.	1	1	100 sq. in.	≤ 100 sq. in. = D-H-60 > 100 sq. in. = D-H-T-W-60	Not Permitted	1	Not Permitted	W-60
					Fire protection			
Other fire barriers	1	¾	Maximum size tested	D-H	¾	D-H		
Fire partitions; Corridor walls	1 0.5	½b ½b	Maximum size tested Maximum size tested	D-20 D-20	¾b ½	D-H-OH-45 D-H-OH-20		
Other fire partitions	1 0.5	¾ ½	Maximum size tested Maximum size tested	D-H-45 D-H-20	¾ ½	D-H-45 D-H-20		
Exterior walls	3	1½	100 sq. in. ^b	≤ 100 sq. in. = D-H-90 > 100 sq. in. = D-H-W-90	Not Permitted	3	Not Permitted	W-180
	2	1½	Maximum size tested	D-H-90 or D-H-W-90	1½	2	D-H-OH-90	W-120
	1	¾	Maximum size tested	D-H-45	¾	D-H-45		
					Fire protection			
Smoke barriers	1	½	Maximum size tested	D-20	¾	D-H-OH-45		

For SI: 1 square inch = 645.2 mm.

- a. Two doors, each with a fire protection rating of 1½ hours, installed on opposite sides of the same opening in a fire wall, shall be deemed equivalent in fire protection rating to one 3-hour fire door.
- b. Fire-resistance-rated glazing tested to ASTM E119 in accordance with Section 716.1.2.3 shall be permitted, in the maximum size tested.
- c. Under the column heading "Fire-rated glazing marking door vision panel" W refers to the fire-resistance rating of the glazing, not the frame.
- d. See Section 716.2.5.1.2.1.
- e. See Section 716.1.2.2.1 and Table 716.1(1) for additional permitted markings.

716.2.5.1.2.2 Fire walls and fire barriers. Fire-protection-rated glazing shall be permitted in fire doors in fire walls and fire barriers having a 1½-hour required fire protection-resistance rating intended for installation in fire barriers greater than 1 hour, where limited to 100 square inches (0.065 m²).

Reason:

Currently, the code's treatment of 100 sq. in. view panels in fire doors is inconsistent. In that regard, the code generally prohibits 100 sq. in. view panels in fire doors that are used in 3- and 4-hour fire walls or fire barriers while it specifically permits their use in fire doors in 3- and 4-hour horizontal exits in fire walls. (See, Table 716.1(2) footnote. d.) This proposal would provide for the consistent treatment of 100 sq. in. view panels in fire doors used in all 3- and 4-hour fire walls and fire barriers.

View panels in fire doors are an important feature of safely moving the general public out of a burning building. While first responders are trained in how to determine whether there is a fire on the other side of a door that you can't see through, the general public does not have that training. Unwittingly opening a door with a fire burning on the other side could seriously compromise the safety of all those attempting to exit the building.

Approving this proposal will improve the safety of exits and make the treatment of view panels in fire doors consistent throughout the code. Additionally, it will make the code consistent with NFPA 80 which permits 100 sq. in. view panels in 3-hour fire doors. (See, NFPA 80-2016, Sections 4.4.4, 4.4.5 and Table 4.4.5).

Cost Impact

The code change proposal will not increase or decrease the cost of construction .

This proposal does not mandate any change in fire doors. Rather, it would, simply, make the treatment of view panels in fire doors consistent throughout the code and with NFPA 80. Since they are already permitted by NFPA 80 and the code already permits them in horizontal exits in fire walls, 3-hour fire doors with view panels are readily available throughout the marketplace.

Internal ID: 400

FS58-18

IBC: 716.2.2.3.1, TABLE 716.1(2)

Proponent: Tom Zaremba, Roetzel & Andress, representing Glazing Industry Code Committee and Alliance of Primary Fire Rated Glazing Manufacturers (tzaremba@ralaw.com)

2018 International Building Code

Revise as follows:

716.2.2.3.1 Glazing in doors. Fire-protection-rated glazing ~~in excess of less than or equal to~~ 100 square inches (0.065 m²) ~~is not permitted. Fire resistance-rated glazing shall be permitted in fire doors. Any fire-rated glazing shall be permitted in excess of 100 square inches (0.065 m²) shall be permitted in fire doors. Listed fire resistance-rated glazing in a fire door shall have if it is listed and labeled as having~~ a maximum transmitted temperature rise in accordance with Section 716.2.2.3 when the *fire door* is tested in accordance with NFPA 252, UL 10B or UL 10C.

**TABLE 716.1(2)
OPENING FIRE PROTECTION ASSEMBLIES, RATINGS AND MARKINGS**

TYPE OF ASSEMBLY	REQUIRED WALL ASSEMBLY RATING (hours)	MINIMUM FIRE DOOR AND FIRE SHUTTER ASSEMBLY RATING (hours)	DOOR VISION PANEL SIZE ^b	FIRE-RATED GLAZING MARKING DOOR VISION PANEL ^{c, e}	MINIMUM SIDELIGHT/TRANSOM ASSEMBLY RATING (hours)		FIRE-RATED GLAZING MARKING SIDELIGHT/TRANSOM PANEL	
					Fire protection	Fire resistance	Fire protection	Fire resistance
Fire walls and fire barriers having a required fire-resistance rating greater than 1 hour	4	3	See Note b	D-H-W-240	Not Permitted	4	Not Permitted	W-240
	3	3a	See Note b	D-H-W-180	Not Permitted	3	Not Permitted	W-180
	2	1½	100 sq. in.	≤ 100 sq. in. = D-H-90 > 100 sq. in. = D-H-W-90	Not Permitted	2	Not Permitted	W-120
	1½	1½	100 sq. in.	≤ 100 sq. in. = D-H-90 > 100 sq. in. = D-H-W-90	Not Permitted	1½	Not Permitted	W-90
Enclosures for shafts, interior exit stairways and interior exit ramps	2	1½	100 sq. in. ^f	<= 100 sq. in. = D-H-90 > 100 sq. in. = D-H-T-90 or D-H-T-W-90	Not Permitted	2	Not Permitted	W-120
Horizontal exits in fire walls ⁴	4	3	100 sq. in.	≤ 100 sq. in. = D-H-180 > 100 sq. in. = D-H-W-240	Not Permitted	4	Not Permitted	W-240
	3	3 ^a	100 sq. in.	≤ 100 sq. in. = D-H-180 > 100 sq. in. = D-H-W-180	Not Permitted	3	Not Permitted	W-180
Fire barriers having a required fire-resistance rating of 1 hour: Enclosures for shafts, exit access stairways, exit access ramps, interior exit stairways and interior exit ramps; and exit passageway walls	1	1	100 sq. in.	<= 100 sq. in. = D-H-60 > 100 sq. in. = D-H-T-60 or D-H-T-W-60	Not Permitted	1	Not Permitted	W-60
					Fire protection			
Other fire barriers	1	¾	Maximum size tested	D-H	¾		D-H	
Fire partitions: Corridor walls	1 0.5	¾ b 1/3 b	Maximum size tested Maximum size tested	D-20 D-20	¾ b 1/3		D-H-OH-45 D-H-OH-20	
Other fire partitions	1 0.5	¾ 1/3	Maximum size tested Maximum size tested	D-H-45 D-H-20	¾ 1/3		D-H-45 D-H-20	
Exterior walls	3	1½	100 sq. in. ^b	≤ 100 sq. in. = D-H-90 > 100 sq. in. = D-H-W-90	Not Permitted	3	Not Permitted	W-180
	2	1½	Maximum size tested	D-H-90 or D-H-W-90	1½	2	D-H-OH-90	W-120
	1	¾	Maximum size tested	D-H-45	¾		D-H-45	
					Fire protection			
Smoke barriers	1	¾	Maximum size tested	D-20	¾		D-H-OH-45	

For SI: 1 square inch = 645.2 mm.

- a. Two doors, each with a fire protection rating of 1½ hours, installed on opposite sides of the same opening in a fire wall, shall be deemed equivalent in fire protection rating to one 3-hour fire door.
- b. Fire-resistance-rated glazing tested to ASTM E119 in accordance with Section 716.1.2.3 shall be permitted, in the maximum size tested.
- c. Under the column heading "Fire-rated glazing marking door vision panel," W refers to the fire-resistance rating of the glazing, not the frame.
- d. See Section 716.2.5.1.2.1.
- e. See Section 716.1.2.2.1 and Table 716.1(1) for additional permitted markings.

Reason:

Section 716.2.2.3 of the IBC mandates that certain fire doors limit the temperature rise on their non-fire exposed side during the first 30-minutes of the fire test ("Temperature Rise Doors"). In Section 716.2.2.3.1, the use of fire-protection rated glazing in such Temperature Rise Doors is limited to 100 sq. in. Fire-resistance rated glazing is permitted in sizes larger than 100 sq. in. if it is listed and labeled as meeting the maximum transmitted temperature rise permitted by Section 716.2.2.3.

Since the adoption of Section 716.2.2.3, a new class of fire-protection rated glazing was developed and is now available in the marketplace. This new type of fire-protection rated glass is specifically designed to limit temperature rise across its surface. Temperature Rise Doors tested using this new class of fire-protection rated glass in sizes greater than 100 sq. in. are now being listed by UL as fully compliant with the temperature rise limitations of Section 716.2.2.3.

The changes to Section 716.2.2.3.1 and Table 716.1(2) proposed here are intended to permit the use of this new class of fire-protection rated glass in Temperature Rise Doors in sizes larger than 100 sq. in. if, and only if, they are listed and labeled as having a maximum transmitted temperature rise in accordance with Section 716.2.2.3.

Cost Impact

The code change proposal will not increase or decrease the cost of construction .

Approving this code change proposal will not increase or decrease the cost of construction since it does not mandate the use of any product. Instead, it will, simply, increase the number of products that specifiers will have to chose from when Temperature Rise Doors are required.

Internal ID: 402

FS59-18

IBC: TABLE 716.1(2)

Proponent: Amber Armstrong, City of Norman (Oklahoma), representing self (amber.armstrong@normanok.gov)

2018 International Building Code

Revise as follows:

TABLE 716.1(2)

OPENING FIRE PROTECTION ASSEMBLIES, RATINGS AND MARKINGS

TYPE OF ASSEMBLY	REQUIRED WALL ASSEMBLY RATING (hours)		MINIMUM FIRE DOOR AND FIRE SHUTTER ASSEMBLY RATING (hours)	DOOR VISION PANEL SIZE ^b	FIRE-RATED GLAZING MARKING DOOR VISION PANEL ^{c, *}	MINIMUM SIDELIGHT/TRANSOM ASSEMBLY RATING (hours)		FIRE-RATED GLAZING MARKING SIDELIGHT/TRANSOM PANEL	
	Single wall assembly rating (hours)	Each wall of the double wall assembly (hours)				Fire protection	Fire resistance	Fire protection	Fire resistance
Fire walls and fire barriers having a required fire-resistance rating greater than 1 hour	4		3	See Note b	D-H-W-240	Not Permitted	4	Not Permitted	W-240
	3		3a	See Note b	D-H-W-180	Not Permitted	3	Not Permitted	W-180
	2		1½	100 sq. in.	≤ 100 sq. in. = D-H-90 > 100 sq. in. = D-H-W-90	Not Permitted	2	Not Permitted	W-120
	1½		1½	100 sq. in.	≤ 100 sq. in. = D-H-90 > 100 sq. in. = D-H-W-90	Not Permitted	1½	Not Permitted	W-90
Double fire wall constructed in accordance with NFPA 221	4	3	3	See Note b	D-H-W-180	Not Permitted	3	Not Permitted	W-180
	3	2	1½	100 sq. in.	≤ 100 sq. in. = D-H-90 > 100 sq. in. = D-H-W-90	Not Permitted	2	Not Permitted	W-120
	2	1	1	100 sq. in.	≤ 100 sq. in. = D-H-60 > 100 sq. in. = D-H-W-60	Not Permitted	1	Not Permitted	W-60
Enclosures for shafts, interior exit stairways and interior exit ramps.	2		1½	100 sq. in. ^c	≤ 100 sq. in. = D-H-90 > 100 sq. in. = D-H-T-W-90	Not Permitted	2	Not Permitted	W-120
Horizontal exits in fire walls ^d	4		3	100 sq. in.	≤ 100 sq. in. = D-H-180 > 100 sq. in. = D-H-W-240	Not Permitted	4	Not Permitted	W-240
	3		3 ^a	100 sq. in.	≤ 100 sq. in. = D-H-180 > 100 sq. in. = D-H-W-180	Not Permitted	3	Not Permitted	W-180
Fire barriers having a required fire-resistance rating of 1 hour: Enclosures for shafts, exit access stairways, exit access ramps, interior exit stairways and interior exit ramps; and exit passageway walls	1		1	100 sq. in.	≤ 100 sq. in. = D-H-60 > 100 sq. in. = D-H-T-W-60	Not Permitted	1	Not Permitted	W-60
Other fire barriers	1		¾	Maximum size tested	D-H	¾	¾	D-H	
Fire partitions: Corridor walls	1 0.5		1/3b 1/3b	Maximum size tested Maximum size tested	D-20 D-20	¾b 1/2	¾b 1/2	D-H-OH-45 D-H-OH-20	
Other fire partitions	1 0.5		¾ 1/3	Maximum size tested Maximum size tested	D-H-45 D-H-20	¾ 1/3	¾ 1/3	D-H-45 D-H-20	
Exterior walls	3		1½	100 sq. in. ^b	≤ 100 sq. in. = D-H-90 > 100 sq. in. = D-H-W-90	Not Permitted	3	Not Permitted	W-180
	2		1½	Maximum size tested	D-H-90 or D-H-W-90	1½	2	D-H-OH-90	W-120
	1		¾	Maximum size tested	D-H-45	¾	¾	D-H-45	
Smoke barriers	1		1/3	Maximum size tested	D-20	¾	¾	D-H-OH-45	

For SI: 1 square inch = 645.2 mm.

- a. Two doors, each with a fire protection rating of 1½ hours, installed on opposite sides of the same opening in a fire wall, shall be deemed equivalent in fire protection rating to one 3-hour fire door.
- b. Fire-resistance-rated glazing tested to ASTM E119 in accordance with Section 716.1.2.3 shall be permitted, in the maximum size tested.
- c. Under the column heading "Fire-rated glazing marking door vision panel," W refers to the fire-resistance rating of the glazing, not the frame.
- d. See Section 716.2.5.1.2.1.
- e. See Section 716.1.2.2.1 and Table 716.1(1) for additional permitted markings.

Reason:

This code change is intended to provide requirements for opening protection in individual walls which are part of a double fire wall constructed in accordance with NFPA 221.

According to IBC Section 706.2, "fire walls designed and constructed in accordance with NFPA 221 shall be deemed to comply with this section." In NFPA 221, 2018 edition, requirements for a specific type of fire wall called a Double Fire Wall are detailed. A Double Fire Wall consists of two walls, parallel to each other which have no connections between them and are independently supported by structural elements on either side. According to NFPA 221 Section 4.6 and Table 4.6, when each wall of a double fire wall assembly is supported by structural elements which have a fire-resistance rating less than that required for the single wall, the fire-resistance rating of each wall may be reduced by one hour. Whether a single wall or a double wall assembly, the walls are still fire walls.

In NFPA 221 Table 4.6, a 4-hour fire wall is allowed to be constructed of two 3-hour fire walls, a 3-hour fire wall is allowed to be constructed of two 2-hour fire walls, and a 2-hour fire wall is allowed to be constructed of two 1-hour walls. In NFPA 221 Table 4.9.2 and IBC Table 716.6(2) one can find requirements for opening protection assemblies for 3-hour fire walls, and 2-hour fire walls, however, there are no requirements for 1-hour walls.

During the 2015-2017 code development cycle, FS 84-15 attempted to provide requirements by creating a single line addition to the table for "Fire walls having a required fire-resistance rating of 1 hour". The committee liked the idea, however, they did not like reference to a 1-hour fire wall. During the Public Comment Hearings, a public comment was submitted which added a foot note that made reference to individual walls as part of a double fire wall assembly. The public comment was not heard because there was still confusion over the concept of a 1-hour fire wall and attempts to overturn the committee decision were unsuccessful.

There are many conditions when construction of two independent walls is a more desirable option than a single fire wall. Openings between the "separate" buildings are common. In NFPA 221, openings in each wall of the double fire wall shall be protected, however there is no direction for fire-resistance ratings for the individual walls. The designer can easily find requirements for the 3-hour and 2-hour fire walls, however, there is no direction for the 1-hour wall. The code official must determine the appropriate rating and their decision is subjective. It is possible that code officials from different jurisdictions will not be consistent.

This code change is more inclusive and clarifies opening protection assemblies for the individual walls which make up the double fire wall. Also, for the 1-hour, individual wall, it is clear that this only exists as a part of a fire wall with a 2-hour fire-resistance rating.

Cost Impact

The code change proposal will not increase or decrease the cost of construction .

The change will not increase the cost of construction because this change clarifies opening protection assemblies in the individual walls are based on the fire-resistance rating of the individual walls which is less than that which would be required for the single wall.

Analysis: The referenced standard,NFPA 221, is currently referenced in other 2018 I-codes.

Internal ID: 2269

FS60-18

IBC: SECTION 202, 202 (New), 716.2.2.1.1

Proponent: John Woestman, Kellen Co., representing Builders Hardware Manufacturers Association (BHMA) (jwoestman@kellencompany.com)

2018 International Building Code

SECTION 202 DEFINITIONS

Add new definition as follows:

TERMINATED STOPS. Factory feature of a door frame where the stops of the door frame are terminated not more than 6 inches from the bottom of the door frame. Terminated stops are also known as "hospital stops" or "sanitary stops".

Revise as follows:

716.2.2.1.1 Smoke and draft control. The air leakage rate of the door assembly shall not exceed 3.0 cubic feet per minute per square foot ($0.01524 \text{ m}^3/\text{s} \times \text{m}^2$) of door opening at 0.10 inch (24.9 Pa) of water for both the ambient temperature and elevated temperature tests. Louvers shall be prohibited. Terminated stops shall be prohibited on doors required by Section 405.4.3 to comply with Section 716.2.2.1 and prohibited on doors required by Section 3006.3 Item 3, 3007.6.3, or 3008.6.3 to comply with Section 716.2.2.1.1.

Reason:

The code today is silent regarding door frames with terminated stops. Interior door frames in many buildings have terminated stops, especially – but not only in – health care facilities. Some interior door frames in business occupancies, and other occupancies, may also have terminated stops.

Unfortunately, the IBC currently does not include an important requirement that door assemblies required to meet the testing requirements of UL1784 when tested without an artificial bottom seal, as required in IBC Sections 405.4.3, 3006.3(3), 3007.6.3, and 3008.6.3, should be prohibited from using door frames with terminated stops. This proposal addresses this oversight.

For other smoke and draft control door assemblies required to be tested to UL1784, this proposal is consistent with the testing requirements of UL 1784.

Terminated stops are a factory feature of a door frame, where the stops are terminated above the floor. The bottom of the stop is closed at a 45-degree or 90-degree angle. The purpose of terminated stops is to make it easier to clean that area of the floor without the extra corners to catch debris or pathogens, and to avoid getting moveable items caught on the stop. Terminated stops are also known as "hospital stops" or "sanitary stops."

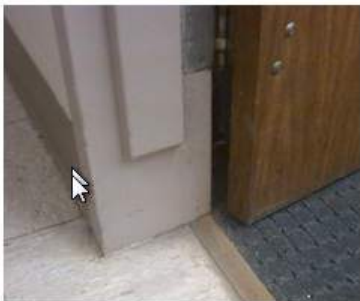

Door frame with terminated stop.

Cost Impact

The code change proposal will not increase or decrease the cost of construction .

This proposal addresses what is currently allowed and prohibited in the code, but not explicitly "spelled out".

Internal ID: 2329

FS61-18

IBC: 716.2.2.3.1, TABLE 716.1(2)

Proponent: Kurt Roeper, ASSA ABLOY, representing ASSA ABLOY (kurt.roeper@assaabloy.com)

2018 International Building Code

Revise as follows:

716.2.2.3.1 Glazing in doors. ~~Fire protection rated glazing in excess of 100 square inches (0.065 m²) is not permitted.~~ Fire protection rated glazing in excess of 100 square inches (0.065 m²) shall be permitted in fire doors where buildings are equipped with an automatic sprinkler system installed in accordance with Section 903.3.1.1 or 903.3.1.2. Where buildings are not equipped with an automatic sprinkler system and the area of glazing in a fire door is greater than 100 square inches (0.65 m²), fire-resistance-rated glazing is required. ~~fire doors.~~ Listed fire-resistance-rated glazing in a ~~fire door~~ shall have a maximum transmitted temperature rise in accordance with Section 716.2.2.3 when the ~~fire door~~ is tested in accordance with NFPA 252, UL 10B or UL 10C.

TABLE 716.1(2)

OPENING FIRE PROTECTION ASSEMBLIES, RATINGS AND MARKINGS

TYPE OF ASSEMBLY	REQUIRED WALL ASSEMBLY RATING (hours)	MINIMUM FIRE DOOR AND FIRE SHUTTER ASSEMBLY RATING (hours)	DOOR VISION PANEL SIZE ^b	FIRE-RATED GLAZING MARKING DOOR VISION PANEL ^{c, e}	MINIMUM SIDELIGHT/TRANSOM ASSEMBLY RATING (hours)		FIRE-RATED GLAZING MARKING SIDELIGHT/TRANSOM PANEL	
					Fire protection	Fire resistance	Fire protection	Fire resistance
Fire walls and fire barriers having a required fire-resistance rating greater than 1 hour	4	3	See Note b	D-H-W-240	Not Permitted	4	Not Permitted	W-240
	3	3a	See Note b	D-H-W-180	Not Permitted	3	Not Permitted	W-180
	2	1½	100 sq. in.	≤ 100 sq. in. = D-H-90 > 100 sq. in. = D-H-W-90	Not Permitted	2	Not Permitted	W-120
	1½	1½	100 sq. in.	≤ 100 sq. in. = D-H-90 > 100 sq. in. = D-H-W-90	Not Permitted	1½	Not Permitted	W-90
Enclosures for shafts, interior exit stairways and interior exit ramps.	2	1½	100 sq. in. ^{c,d}	≤ 100 sq. in. = D-H-90 > 100 sq. in. = D-H-T-W-90 or D-H-90	Not Permitted	2	Not Permitted	W-120
Horizontal exits in fire walls ^d	4	3	100 sq. in.	≤ 100 sq. in. = D-H-180 > 100 sq. in. = D-H-W-240	Not Permitted	4	Not Permitted	W-240
	3	3 ^a	100 sq. in.	≤ 100 sq. in. = D-H-180 > 100 sq. in. = D-H-W-180	Not Permitted	3	Not Permitted	W-180
Fire barriers having a required fire-resistance rating of 1 hour; Enclosures for shafts, exit access stairways, exit access ramps, interior exit stairways and interior exit ramps; and exit passageway walls	1	1	100 sq. in.	≤ 100 sq. in. = D-H-60 > 100 sq. in. = D-H-T-W-60 or D-H-60	Not Permitted	1	Not Permitted	W-60
					Fire protection			
Other fire barriers	1	¾	Maximum size tested	D-H	¾		D-H	
Fire partitions; Corridor walls	1 0.5	½b 1½b	Maximum size tested Maximum size tested	D-20 D-20	¾b ½		D-H-OH-45 D-H-OH-20	
Other fire partitions	1 0.5	¾ 1½	Maximum size tested Maximum size tested	D-H-45 D-H-20	¾ 1/3		D-H-45 D-H-20	
Exterior walls	3	1½	100 sq. in. ^b	≤ 100 sq. in. = D-H-90 > 100 sq. in. = D-H-W-90	Not Permitted	3	Not Permitted	W-180
	2	1½	Maximum size tested	D-H-90 or D-H-W-90	1½	2	D-H-OH-90	W-120
	1	¾	Maximum size tested	D-H-45	¾		D-H-45	
					Fire protection			
Smoke barriers	1	1/3	Maximum size tested	D-20	¾		D-H-OH-45	

For SI: 1 square inch = 645.2 mm.

- a. Two doors, each with a fire protection rating of 1½ hours, installed on opposite sides of the same opening in a fire wall, shall be deemed equivalent in fire protection rating to one 3-hour fire door.
- b. Fire-resistance-rated glazing tested to ASTM E119 in accordance with Section 716.1.2.3 shall be permitted, in the maximum size tested.
- c. Under the column heading "Fire-rated glazing marking door vision panel" W refers to the fire-resistance rating of the glazing, not the frame.
- d. See Section 716.2.5.1.2.1.
- e. See Section 716.1.2.2.1 and Table 716.1(1) for additional permitted markings.
- f. Except where the building is equipped throughout with an automatic sprinkler system and the fire-rated glazing is in accordance with Section 716.2.2.3.1.

Reason:

Per the exception in 716.2.2.3, the maximum transmitted temperature rise is not required in buildings equipped throughout with an automatic sprinkler system. As written, section 716.2.2.3.1 does not provide the same exception for glazing in excess of 100 square inches in a door. This proposed change provides consistency of the performance requirements between the door and glazing when the exception is exercised.

Cost Impact

The code change proposal will decrease the cost of construction .

The proposal will decrease the cost of construction in cases where the exception of 716.2.2.3 has been exercised

Internal ID: 2293

FS62-18

IBC: 202, 717.2, 717.2.3 (New), 717.3.1; IMC 202, 607.2, 607.3.1

Proponent: Jonathan Roberts, UL LLC, representing UL LLC (jonathan.roberts@ul.com)

2018 International Building Code

SECTION 202 DEFINITIONS

Revise as follows:

[BF] CEILING RADIATION DAMPER. A listed device installed in a ceiling membrane of a fire-resistance-rated floor/ceiling or roof/ceiling assembly to limit automatically the radiative heat transfer through an air inlet/outlet opening. Ceiling radiation dampers include air terminal units, ceiling dampers and ceiling air diffusers. Ceiling radiation dampers are classified for use in either static systems that will automatically shut down in the event of a fire, or in dynamic systems that continue to operate during a fire. A dynamic ceiling radiation damper is tested and rated for closure under elevated temperature airflow.

717.2 Installation. Fire dampers, smoke dampers, combination fire/smoke dampers and ceiling radiation dampers located within air distribution and smoke control systems shall be installed in accordance with the ~~requirements of this section, the manufacturer's instructions and the dampers' listing,~~ listing and Sections 717.2.1 through 717.2.3.

Add new text as follows:

717.2.3 Static dampers. Fire dampers and ceiling radiation dampers that are listed for use in static systems shall only be installed in heating, ventilation and air-conditioning systems that are automatically shut down in the event of a fire.

Revise as follows:

717.3.1 Damper testing. *Dampers* shall be listed and labeled in accordance with the standards in this section.

1. *Fire dampers* shall comply with the requirements of UL 555. ~~Only fire dampers labeled for use in dynamic systems shall be installed in heating, ventilation and air conditioning systems designed to operate with fans on during a fire.~~
2. *Smoke dampers* shall comply with the requirements of UL 555S.
3. *Combination fire/smoke dampers* shall comply with the requirements of both UL 555 and UL 555S.
4. *Ceiling radiation dampers* shall comply with the requirements of UL 555C or shall be tested as part of a fire-resistance-rated floor/ceiling or roof/ceiling assembly in accordance with ASTM E119 or UL 263. Only *ceiling radiation dampers* labeled for use in dynamic systems shall be installed in heating, ventilation and air-conditioning systems designed to operate with fans on during a fire.
5. *Corridor dampers* shall comply with requirements of both UL 555 and UL 555S. *Corridor dampers* shall demonstrate acceptable closure performance when subjected to 150 feet per minute (0.76 mps) velocity across the face of the *damper* during the UL 555 fire exposure test.

Reason:

The reason for the definition change is that UL 555C now has requirements to test ceiling radiation dampers for either closure under dynamic or static conditions. This information is also included in the definition of "fire damper"

The last sentence in Items 1 and 4 regarding dynamic-type fire dampers and ceiling radiation dampers are installation requirements, not testing requirements. These requirements should be in Section 717.2. Static-type fire dampers and ceiling radiation dampers have been evaluated only for use where the air movement is effectively stopped at the start of a fire. Dynamic-type fire dampers and ceiling radiation dampers, as well as smoke dampers, combination fire/smoke dampers, and corridor dampers, have been evaluated been evaluated for use in HVAC systems where the airflow is operational at the time of a fire, such as in a smoke-control system, or from other situations in which the fan system is operational at the time of a fire. Also, Section 717.2, and the subsections, apply to the installation of dampers.

Cost Impact

The code change proposal will not increase or decrease the cost of construction .

This proposal relocates the existing installation requirements for ceiling radiation dampers to the appropriate code section.

FS63-18

IBC 717.3.1 (IMC 607.3.1)

Proponent: Guy McMann, representing Colorado Association of Plumbing and Mechanical Officials (CAPMO)
(gmcman@jeffco.us)

2018 International Building Code

Revise as follows:

717.3.1 Damper testing. *Dampers* shall be listed and labeled in accordance with the standards in this section.

1. *Fire dampers* shall comply with the requirements of UL 555. Only fire *dampers* labeled for use in dynamic systems shall be installed in heating, ventilation and air-conditioning systems designed to operate with fans on during a fire.
2. *Smoke dampers* shall comply with the requirements of UL 555S.
3. *Combination fire/smoke dampers* shall comply with the requirements of both UL 555 and UL 555S.
4. *Ceiling radiation dampers* shall comply with the requirements of UL 555C or shall be tested as part of a fire-resistance-rated floor/ceiling or roof/ceiling assembly in accordance with ASTM E119 or UL 263. Only *ceiling radiation dampers* labeled for use in dynamic systems shall be installed in heating, ventilation and air-conditioning systems designed to operate with fans on during a fire.

Exception: Ceiling radiation dampers shall not be required to be dynamic rated in dwelling unit HVAC systems where the air handler is shut off upon detection of smoke by the smoke alarms installed in the dwelling unit.

5. *Corridor dampers* shall comply with requirements of both UL 555 and UL 555S. *Corridor dampers* shall demonstrate acceptable closure performance when subjected to 150 feet per minute (0.76 mps) velocity across the face of the *damper* during the UL 555 fire exposure test.

Reason:

At this point in time there are no manufacturers of ceiling radiation dampers (crd's) rated for use in dynamic systems. The code is calling for a requirement that is not available but these fire dampers are being installed in every R-2 being built today with little repercussions. The code says these dampers aren't permitted but gives no guidance as to what to do about it. Non-dynamic rated crd's will continue to be installed in dynamic systems regardless because there are no other options. R-2's will continue to be built. This proposal provides a solution to the dilemma and provides a safe alternative to the problem by tying the smoke detectors to the air handlers there by stopping the airflow which will permit the damper to release the way it was designed to do. The manufacturers have no plans to test their products as there is little motivation to do so .

Cost Impact

The code change proposal will not increase or decrease the cost of construction .

This proposal in editorial in nature

Internal ID: 143

FS64-18

IBC: 717.3.1 (IMC 607.3.1), 717.6.2.1.1 (New), 717.6.2.1.2 (New);

Proponent: Eirene Knott, representing Metropolitan Kansas City Chapter of the ICC (Eirene.Knott@brrarch.com)

2018 International Building Code

Revise as follows:

717.3.1 Damper testing. *Dampers* shall be listed and labeled in accordance with the standards in this section.

1. *Fire dampers* shall comply with the requirements of UL 555. Only fire *dampers* labeled for use in dynamic systems shall be installed in heating, ventilation and air-conditioning systems designed to operate with fans on during a fire.
2. *Smoke dampers* shall comply with the requirements of UL 555S.
3. *Combination fire/smoke dampers* shall comply with the requirements of both UL 555 and UL 555S.
4. *Ceiling radiation dampers* shall comply with the requirements of UL 555C or shall be tested as part of a fire-resistance-rated floor/ceiling or roof/ceiling assembly in accordance with ASTM E119 or UL 263. ~~Only ceiling radiation dampers labeled for use in dynamic systems shall be installed in heating, ventilation and air-conditioning systems designed to operate with fans on during a fire.~~
5. *Corridor dampers* shall comply with requirements of both UL 555 and UL 555S. *Corridor dampers* shall demonstrate acceptable closure performance when subjected to 150 feet per minute (0.76 mps) velocity across the face of the *damper* during the UL 555 fire exposure test.

Add new text as follows:

717.6.2.1.1 Dynamic systems. Only ceiling radiation dampers labeled for use in dynamic systems shall be installed in heating, ventilation and air-conditioning systems designed to operate with fans on during a fire.

717.6.2.1.2 Static systems. Static dampers shall be provided with systems which are not designed to operate during a fire.

Exceptions:

1. Where a static ceiling radiation damper is installed at the opening of a duct, a smoke detector shall be installed inside the duct or outside the duct with sampling tubes protruding into the duct. The detector or tubes within the duct shall be within 5 feet (1524 mm) of the damper. Air outlets and inlets shall not be located between the detector or tubes and the damper. The detector shall be listed for the air velocity, temperature and humidity anticipated at the point where it is installed. Other than in mechanical smoke control systems, dampers shall be closed upon fan shutdown where local smoke detectors require a minimum velocity to operate.
2. Where a static ceiling radiation damper is installed in a ceiling, the damper shall be permitted to be controlled by a smoke detection system installed within the same room as the ceiling radiation damper.
3. Where a static ceiling radiation damper is installed in an area served by the duct in which the damper will be located, the ceiling radiation damper shall be permitted to be controlled by the smoke detection system.
4. Where a ceiling radiation damper is installed within a room and an occupant sensor is provided within the room served by the damper, a static damper shall be permitted.

Reason:

The purpose behind this code change is to provide some direction on the use of dynamic versus static ceiling radiation dampers (CRD's). As of the writing of this proposed code change, there are no UL listed CRD's that are dynamic; I have confirmed this with UL.

Under the 2018 IBC/IMC, if a CRD is required in a floor/ceiling assembly, the only choice is to utilize a static damper since no dynamic dampers are available. Under a static system, there can be no air movement within the duct once the system is shut down. So, unless a system is designed to shut down with activation of a smoke detector or other detection device, a static damper cannot be used unless the entire system is designed to shut down upon activation of an initiation device. Exhaust systems and 100 percent outside air systems fall into the definition of static systems as

they do not shut down at the activation of an initiation device. As a result, these systems would then be required to provide dynamic dampers. Since CRD's do not exist in the dynamic form, there is no clear direction within the code as to how a static system could be designed to utilize static CRD's. This provides limitations to the designer on how to design an exhaust or outside air system within floor/ceiling or roof/ceiling assemblies.

If we use an R-1 occupancy as an example, some hotel brands utilize interstitial space within the floor/ceiling assembly to convey toilet room exhaust. Because there is no clear direction in the IBC or the IMC some hotel brands are providing a sensor of some sort on each exhaust fan serving the toilet room within each sleeping unit because the CRD is being required to stop the flow of air. One option that is being utilized to overcome this missing direction is to provide an occupant sensor within the toilet room that controls the activation of the exhaust fan. If the toilet room is vacant, the exhaust fan is not running and therefore the system is static. I believe this proposed code change would achieve the protection that is expected by the IBC/IMC as well as providing options for the design professional to have choices in their system layout/function.

Cost Impact

The code change proposal will increase the cost of construction .

While I cannot confirm the exact cost impact that this code change would provide, by giving the designer some options for using static dampers, this should potentially decrease the cost of construction.

Internal ID: 302

FS65-18

IBC: 717.3.3.1

Proponent: William Koffel, representing Air Movement and Control Association (wkoffel@koffel.com)

2018 International Building Code

Revise as follows:

717.3.3.1 Fire damper ~~actuation device~~ **actuation.** ~~The fire damper actuation device~~ Primary heat responsive devices used to actuate fire dampers shall meet one of the following requirements:

1. The operating temperature shall be approximately 50°F (10°C) above the normal temperature within the duct system, but not less than 160°F (71°C).
2. The operating temperature shall be not more than 350°F (177°C) where located in a smoke control system complying with Section 909.

Reason:

"Primary heat responsive device" is the terminology used in UL 555 and as such, should be the phrase used in the IBC. The change in the title is consistent with the title used for smoke damper actuation.

Cost Impact

The code change proposal will not increase or decrease the cost of construction .

The proposal will have no impact on the cost of construction. It is simply a change in terminology to be consistent with the UL test standard.

Internal ID: 1549

FS66-18

IBC: 717.4, 717.4.1 (New), 717.4.1.1 (New), 717.4.1.2 (New), 717.4.2 (New), 717.4.3 (New)

Proponent: William Koffel, representing Air Movement and Control Association (wkoffel@koffel.com)

2018 International Building Code

Revise as follows:

717.4 Access and identification and periodic inspection and testing. Access, identification and periodic inspection and testing of fire and smoke dampers shall comply with Sections 717.4.1 through 717.4.3.

Add new text as follows:

717.4.1 Access. Fire and smoke dampers shall be provided with an approved means of access that is large enough to permit inspection and maintenance of the damper and its operating parts.

717.4.1.1 Access openings. The access shall not affect the integrity of fire-resistance-rated assemblies. The access openings shall not reduce the fire-resistance rating of the assembly. Access doors in ducts shall be tight fitting and suitable for the required duct construction.

717.4.1.2 Restricted access . Where space constraints or physical barriers restrict access to a damper for periodic inspection and testing, the damper shall be a single- or multi-blade type damper and shall comply with the remote inspection requirements of NFPA 80 or NFPA 105

717.4.2 Identification. Access points shall be permanently identified on the exterior by a label having letters not less than 1/2 inch (12.7 mm) in height reading: FIRE/SMOKE DAMPER, SMOKE DAMPER or FIRE DAMPER.

717.4.3 Periodic inspection and testing. Periodic inspection and testing of fire dampers shall be in accordance with NFPA 80. Periodic inspection and testing of smoke dampers shall be in accordance with NFPA 105. Periodic inspection and testing of combination fire/smoke dampers shall be in accordance with NFPA 80 and NFPA 105.

Reason:

It is understood that periodic inspection and testing is typically within the scope of the IFC. However, it is not uncommon to alert interested parties to these requirements in the IBC (for example see Chapter 9). In this instance it is important for the design professional to be aware of the inspection and testing requirements since they impact the access requirements contained in the IBC. In addition, the proposal provides design professionals with an alternative of remote testing (as permitted by NFPA 80 and NFPA 105) in situations where adequate access for inspection and testing cannot be provided.

Cost Impact

The code change proposal will not increase or decrease the cost of construction .

The alternative for remote testing does not impact the cost of construction because it is not required. However, recognizing that remote testing is an option may actually decrease the cost of construction in instances where providing adequate access is challenging.

Analysis. The proposal takes existing Section 717.4 and breaks it into subsections. Much of the text in the subsections is existing text redistributed from 717.4. The cdpACCESS system parameters result in showing new sections as having new text even where the text is not new but is being reorganized.

Internal ID: 1551

FS67-18

IBC: 717.5.2 (IMC 607.5.2)

Proponent: John Williams, Chair, representing Healthcare Committee (AHC@iccsafe.org)

2018 International Building Code

Revise as follows:

717.5.2 Fire barriers. Ducts and air transfer openings of *fire barriers* shall be protected with *listed fire dampers* installed in accordance with their listing. Ducts and air transfer openings shall not penetrate enclosures for *interior exit stairways* and *ramps* and *exit passageways*, except as permitted by Sections 1023.5 and 1024.6, respectively.

Exception: *Fire dampers* are not required at penetrations of *fire barriers* where any of the following apply:

1. Penetrations are tested in accordance with ASTM E119 or UL 263 as part of the fire-resistance-rated assembly.
2. Ducts are used as part of an *approved* smoke control system in accordance with Section 909 and where the use of a *fire damper* would interfere with the operation of a smoke control system.
3. Such walls are penetrated by fully ducted HVAC systems, have a required *fire-resistance rating* of 1 hour or less, are in areas of other than Group H and are in buildings equipped throughout with an *automatic sprinkler system* in accordance with Section 903.3.1.1 or 903.3.1.2. For the purposes of this exception, a fully ducted HVAC system shall be a duct system for conveying supply, return or exhaust air as part of the structure's HVAC system. Such a duct system shall be constructed of sheet steel not less than No. 26 gage thickness and shall be continuous from the air-handling appliance or equipment to the air outlet and inlet terminals. Flexible air connectors shall be permitted in the following locations:
 - 3.1. Non-metal flex connections shall be permitted at the duct connection to the air handling unit or equipment located within the mechanical room in accordance with Section 603.9 of the International Mechanical Code.
 - 3.2. Non-metal flex connections shall be permitted from an overhead metal duct to a ceiling diffuser within the same room in accordance with Section 603.6.2 of the International Mechanical Code.

Reason:

The intention of this code change is to more accurately reflect typical installations found in most buildings. As currently written, the code implies that any flex duct (or equipment flexible connections) negates the use of the exception for fire dampers in 1 hour walls in fully ducted, fully sprinklered buildings.

The code permits the omission of the fire damper for a metal duct system that terminates either at a wall (such as a sidewall grille) or continues on to a duct opening past the fire barrier and has openings in the duct ("continuous from the air-handling appliance or equipment to the air outlet and inlet terminals"). This section does not prohibit openings to be on both sides of the duct as long as the openings are in metal duct. However, as currently written, if flex duct is used to connect a metal duct to a ceiling diffuser (standard practice) this triggers the requirement for a fire damper.

The flex connection within the concealed space does not constitute a greater hazard than other conditions that would permit the omission of the fire dampers (see attached sketches below).

FULLY SPRINKLERED BUILDING
FULLY DUCTED HVAC

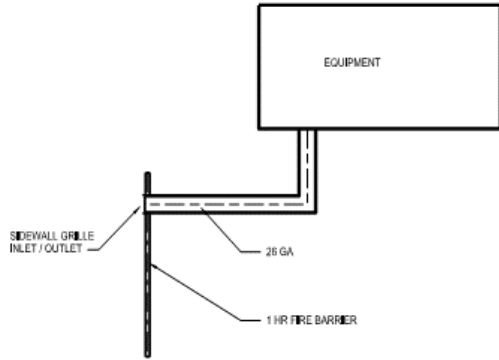

NO FIRE DAMPER REQUIRED

FULLY SPRINKLERED BUILDING
FULLY DUCTED HVAC

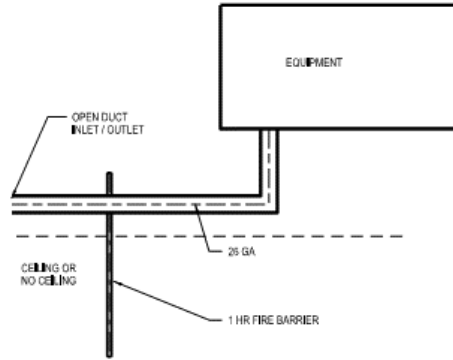

NO FIRE DAMPER REQUIRED

FULLY SPRINKLERED BUILDING
FULLY DUCTED HVAC

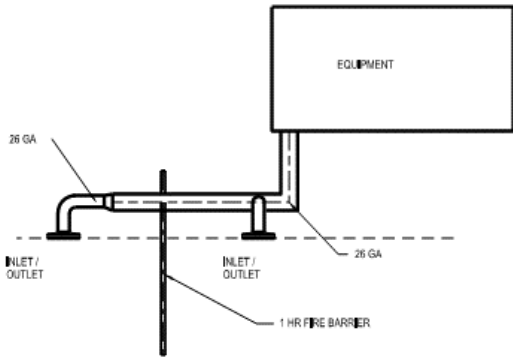

NO FIRE DAMPER REQUIRED

FULLY SPRINKLERED BUILDING
FULLY DUCTED HVAC

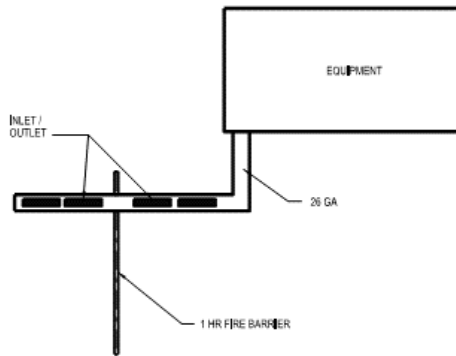

NO FIRE DAMPER REQUIRED

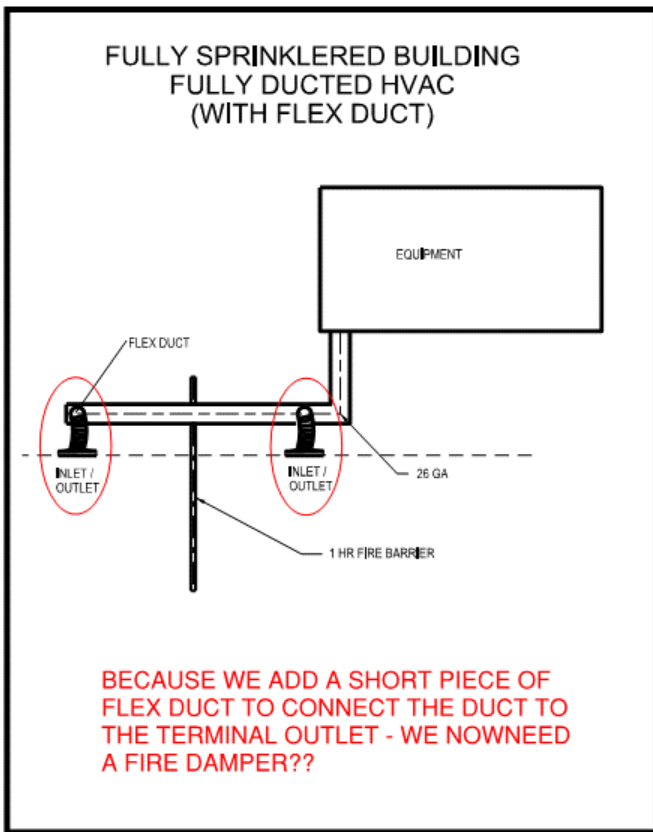

Likewise, a flex connection at the AHU within the mechanical space does not constitute a hazard that should trigger the fire damper within the system

As proposed, this section will coordinate with the requirements already established in the International Mechanical Code. IMC Section 606.6.3 limits the design air temperature for flexible air connectors to 250 degrees F (121 C). Under the vast majority of conditions where flexible air connectors will be used (installed above a ceiling, light or ordinary hazard occupancy, ordinary or intermediate temperature sprinklers, quick or standard response), the sprinkler response can be demonstrated by calculation to occur before the ceiling jet temperature from a fire reaches the limit of 606.6.3.

The intention is to maintain the allowance of flexible connectors at the terminal end of hard ductwork within the room of the air register. This public comment maintains the requirements of the IMC, including:

- Limiting the length of the flexible connector to 14 feet actual length.

- Requiring the flexible connector to be tested in accordance with UL 181.

- Requiring use only at the end of hard ductwork.

- Maintains the requirement for hard ductwork to pass through the barrier.

This allows constructability of a fully ducted system, and maintains the integrity of the system throughout the building.

It is not the intention of the code change to allow flexible ducts through any vertical barriers (as already prohibited by Section 717.7). The flexible ductwork is only to be allowed within a room, and above the ceiling. See the sketch below to better clarify the intention.

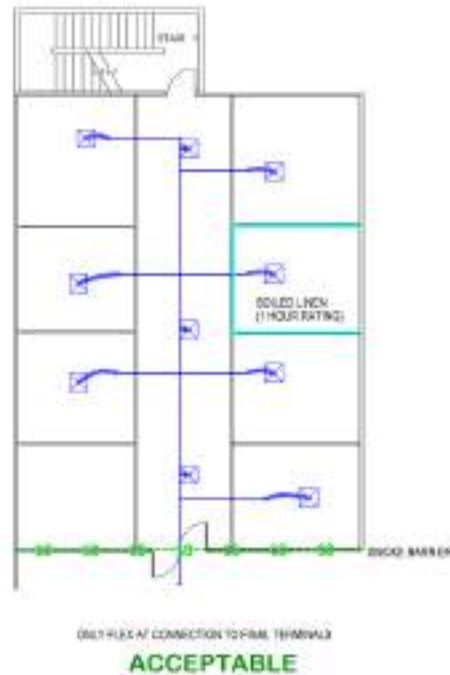
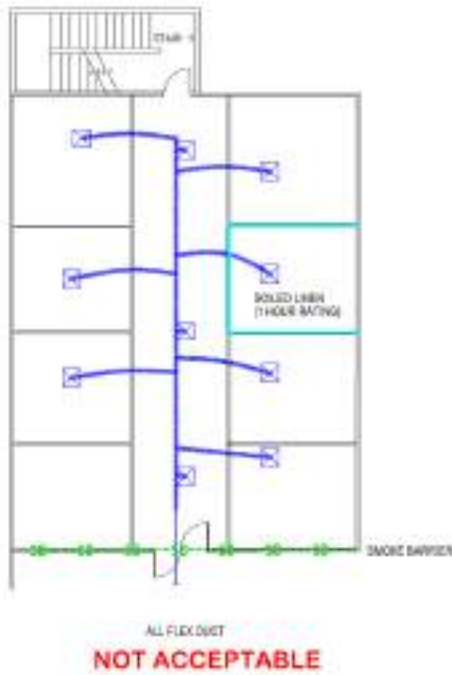

This proposal is submitted by the ICC Committee on Healthcare (CHC). The CHC was established by the ICC Board to evaluate and assess contemporary code issues relating to healthcare facilities. This is a joint effort between ICC and the American Society for Healthcare Engineering (ASHE), a subsidiary of the American Hospital Association, to eliminate duplication and conflicts in healthcare regulation. In 2017 the CHC held 2 open meetings and numerous conference calls, which included members of the committees as well as any interested parties, to discuss and debate the proposed changes. Information on the CHC, including: meeting agendas; minutes; reports; resource documents; presentations; and all other materials developed in conjunction with the CHC effort can be downloaded from the CHC website at: <https://www.iccsafe.org/codes-tech-support/cs/icc-committee-on-healthcare/>.

Cost Impact

The code change proposal will decrease the cost of construction .

This proposed code change would result in a decrease in construction cost since this will eliminate fire dampers where the building/installation complies with the requirements of the proposed exception. Where a building does not meet the requirements of the proposed exception, there would be no change in construction cost (dampers would still be required as they are now).

Internal ID: 1286

FS68-18

IBC: 717.5.2 (IMC 607.5.2)

Proponent: Mark Jelinske, representing Self (mjelinske@rmhgroup.com)

2018 International Building Code

Revise as follows:

717.5.2 Fire barriers. Ducts and air transfer openings of *fire barriers* shall be protected with *listed fire dampers* installed in accordance with their listing. Ducts and air transfer openings shall not penetrate enclosures for *interior exit stairways* and *ramps* and *exit passageways*, except as permitted by Sections 1023.5 and 1024.6, respectively.

Exception: *Fire dampers* are not required at penetrations of *fire barriers* where any of the following apply:

1. Penetrations are tested in accordance with ASTM E119 or UL 263 as part of the fire-resistance-rated assembly.
2. Ducts are used as part of an *approved* smoke control system in accordance with Section 909 and where the use of a *fire damper* would interfere with the operation of a smoke control system.
3. ~~Such walls are penetrated by ducted HVAC systems, have a required *fire resistance rating* of 1 hour or less, are in areas of other than Group H and are in buildings equipped throughout with an *automatic sprinkler system* in accordance with Section 903.3.1.1 or 903.3.1.2. For the purposes of this exception, a ducted HVAC system shall be a duct system for conveying supply, return or exhaust air as part of the structure's HVAC system. Such a duct system shall be constructed of sheet steel not less than No. 26 gage thickness and shall be continuous from the air handling appliance or equipment to the air outlet and inlet terminals.~~

Reason:

There is no empirical evidence showing that the integrity of a Fire Barrier is not compromised by a ducted penetration simply because the building is protected by sprinklers.

It might be argued that since this exception can only be used in a fully sprinklered building, the challenge to the Fire Barrier is much less than the time/temperature curve of the ASTM/UL test. However, the extent and rating of Fire Barriers is already greatly reduced in a fully sprinklered building; so the counter argument is that the Fire Barriers in a fully sprinklered building are very important and constitute the "last stand" of the passive Life Safety features of a building. These should not rely on an active means of protection. The protection for no other penetration or opening is allowed to be eliminated simply due to sprinklers.

Where dampers are not desired, exception 1 already has the provision for an assembly tested in accordance with ASTM E119 or UL 263. Such an assembly has shown evidence of maintaining the integrity of fire resistive construction. This should be the standard for a "last stand" passive Life Safety feature.

Note that this proposal does not include eliminating the similar exception for Fire Dampers in Fire Partitions. Fire Partitions are already considered a lower level of protection, and therefore a lower standard for protection is appropriate.

Cost Impact

The code change proposal will increase the cost of construction .

Since an exception is being eliminated, some additional dampers will be required. But the extent of Fire Barriers in most occupancies is already reduced with sprinklers. Further, the ability to apply this exception is not that common for the remaining Fire Barriers in sprinklered buildings, since the common case of HVAC system using flexible duct, flexible equipment connections, or flexible seismic joints disqualify such systems from being considered "ducted".

Internal ID: 1113

FS69-18

IBC: 717.5.3

Proponent: Raymond Grill, Arup, representing Self (ray.grill@arup.com)

2018 International Building Code

Revise as follows:

717.5.3 Shaft enclosures. Shaft enclosures that are permitted to be penetrated by ducts and air transfer openings shall be protected with *listed* fire and *smoke dampers* installed in accordance with their listing.

Exceptions:

1. *Fire dampers* are not required at penetrations of shafts where any of the following criteria are met:
 - 1.1. Steel exhaust subducts are extended not less than 22 inches (559 mm) vertically in exhaust shafts, provided that there is a continuous airflow upward to the outside.
 - 1.2. Penetrations are tested in accordance with ASTM E119 or UL 263 as part of the fire-resistance-rated assembly.
 - 1.3. Ducts are used as part of an approved smoke control system designed and installed in accordance with Section 909 and where the *fire damper* will interfere with the operation of the smoke control system.
 - 1.4. The penetrations are in parking garage exhaust or supply shafts that are separated from other building shafts by not less than 2-hour fire-resistance-rated construction.
2. ~~In Group B and R occupancies equipped throughout with an *automatic sprinkler system* in accordance with Section 903.3.1.1, *smoke dampers* are not required at penetrations of shafts where all of the following criteria are met:~~
 - ~~2.1. Kitchen, clothes dryer, bathroom and toilet room exhaust openings are installed with steel exhaust subducts, having a minimum wall thickness of 0.0187 inch (0.4712 mm) (No. 26 gage).~~
 - ~~2.2. The subducts extend not less than 22 inches (559 mm) vertically.~~
 - ~~2.3. An exhaust fan is installed at the upper terminus of the shaft that is powered continuously in accordance with the provisions of Section 909.11, so as to maintain a continuous upward airflow to the outside.~~
3. *Fire and smoke dampers* are not required at penetration of exhaust or supply shafts in parking garages that are separated from other building shafts by not less than 2-hour fire-resistance-rated construction.
4. *Smoke dampers* are not required at penetrations of shafts where ducts are used as part of an *approved* mechanical smoke control system designed in accordance with Section 909 and where the *smoke damper* will interfere with the operation of the smoke control system.
5. *Fire dampers* and *combination fire/smoke dampers* are not required in kitchen and clothes dryer exhaust systems where *dampers* are prohibited by the International Mechanical Code.

Reason:

The requirement for smoke dampers at penetrations in shafts was first included in the IBC during the comment phase of the development of the first edition of the International Building Code. This requirement did not exist in any of the model building codes (BOCA, UBC & SBC). A requirement for smoke dampers at penetrations of shafts has never been incorporated in the NFPA system of codes. The justification for smoke dampers in the original code change is that smoke can travel through a duct to locations in a building that are remote from the fire. While this statement is correct, smoke travel through ducted ventilation shafts has not been a contributing factor to firespread or fire deaths in buildings. Smoke detectors at HVAC equipment have been required to accomplish automatic shut off of HVAC equipment to minimize the potential of smoke spread through ventilation ducts. For example, the majority of fire deaths in upper stories of the MGM Grand fire of 1980 were due to smoke spread through stair shafts and seismic joints that were not protected. Fancoil units in guestrooms drew air from the corridors which also contributed to fatalities. While the HVAC system was cited as a potential source of smokespread, smoke detectors were not present

to provide automatic shutoff of equipment (NFPA Preliminary Report of the MGM Grand Hotel Fire). The MGM Grand was not sprinkler protected.

There was only one fatality in an upper story of the San Juan DuPont fire in 1986 which was not readily explained. The San Juan Dupont was not sprinkler protected. Smoke travel through ventilation shafts was not a contributing factor in the First Interstate fire in Los Angeles or the Meridian fire in Philadelphia. Sprinklers were not active on fire floors in either of those buildings. Even in the World Trade Center bombing of 1993, 6 fatalities were attributed to the explosion, but there were no fatalities due to the effects of smoke (Isner, Michael S. and Klem, Thomas J., "World Trade Center Explosion and Fire," National Fire Protection Association). While these fires were thoroughly investigated, and code changes promulgated to address fire safety issues, smoke dampers in duct penetrations of shafts were never adopted as changes to any of the model codes as a result of these fires.

The original code change in the IBC did not present any technical substantiation for the additional requirement for smoke dampers and there has never been an instance that I am aware of where the provision of smoke dampers in shafts would have made a difference in the fire performance of a fully sprinklered building.

This requirement has been massaged based on negotiation with manufacturers and building ownership groups over the past code cycles because it has always been difficult to implement. The requirement for smoke dampers at penetrations of shafts should be removed for fully sprinklered buildings.

There have been jurisdictions (District of Columbia and Commonwealth of Virginia) and federal agencies that have never adopted the smoke damper requirement for sprinklered buildings. There have not been any incidences reported to show a need for smoke dampers. Agencies include the General Services Administration, Department of Veteran Affairs, and Department of Defense. These agencies own and operate buildings that include all of the occupancy types addressed by the IBC. Smoke dampers are not required in shaft penetrations in their buildings.

Performance of Fully Sprinklered Buildings

It is important to note that the IBC requires sprinkler protection for most buildings of any significant size or occupant load. Therefore, the performance of sprinklered buildings is relevant. There has never been a multiple life loss fire in a fully sprinklered building of any occupancy type where the occupants have not been intimate with the fire or where an explosive or terrorist event has occurred.

Fire incidents in fully sprinklered buildings have never been identified to demonstrate the need for smoke dampers at shaft penetrations..

Maintaining Operability

Smoke dampers are operated by either a pneumatic actuator or electric motor. Smoke dampers require regular testing and maintenance to keep them operating. Even the most diligent building owners have a difficult time maintaining operability of smoke dampers.

Sustainability

There is a significant amount of resources that go into the implementation of smoke dampers at shaft penetrations. There has not been a demonstrated value to property protection or life safety in fully sprinklered buildings to justify their need.

Cost Impact

The code change proposal will decrease the cost of construction .

This code change will significantly reduce the cost of construction. A rough installed cost estimate for the smoke dampers and associated required equipment can range from \$2000-\$3000 per damper or even more for large dampers. This does not include the ongoing cost of testing the dampers and detectors that are required to operate the dampers. Regular testing is also required at regular frequencies. Testing costs per damper can vary depending on the number of dampers being tested and the accessibility and complexity of the system.

Internal ID: 2307

FS70-18

IBC: 717.5.3 (IMC [BF] 607.5.5) , 717.5.3.1 (New)

Proponent: Michael O'Brian, Chair, representing FCAC (fcac@iccsafe.org)

2018 International Building Code

Revise as follows:

717.5.3 Shaft enclosures. Shaft enclosures that are permitted to be penetrated by ducts and air transfer openings shall be protected with *listed* fire and *smoke dampers* installed in accordance with their listing.

Exceptions:

1. *Fire dampers* are not required at penetrations of shafts where any of the following criteria are met:
 - 1.1. Steel exhaust subducts having a wall thickness of not less than 0.0187 inch (0.4712 mm) are extended not less than 22 inches (559 mm) vertically in exhaust shafts, ~~provided that there is a continuous airflow upward to the outside and an exhaust fan is installed at the upper terminus of the shaft that is powered continuously in accordance with Section 909.11, so as to maintain a continuous upward airflow to the outdoors.~~
 - 1.2. Penetrations are tested in accordance with ASTM E119 or UL 263 as part of the fire-resistance-rated assembly.
 - 1.3. Ducts are used as part of an approved smoke control system designed and installed in accordance with Section 909 and where the *fire damper* will interfere with the operation of the smoke control system.
 - 1.4. The penetrations are in parking garage exhaust or supply shafts that are separated from other building shafts by not less than 2-hour fire-resistance-rated construction.
2. In Group B and R occupancies equipped throughout with an *automatic sprinkler system* in accordance with Section 903.3.1.1, *smoke dampers* are not required at penetrations of shafts where all of the following criteria are met:
 - 2.1. Kitchen, clothes dryer, bathroom and toilet room exhaust openings are installed with steel exhaust subducts, having a ~~minimum~~ wall thickness of not less than 0.0187-inch (0.4712 mm) (No. 26 gage).
 - 2.2. The subducts extend not less than 22 inches (559 mm) vertically.
 - 2.3. An exhaust fan is installed at the upper terminus of the shaft that is powered continuously in accordance with the provisions of Section 909.11, so as to maintain a continuous upward airflow to the ~~outside-outdoors.~~
3. *Smoke dampers* are not required at penetration of exhaust or supply shafts in parking garages that are separated from other building shafts by not less than 2-hour fire-resistance-rated construction.
4. *Smoke dampers* are not required at penetrations of shafts where ducts are used as part of an *approved* mechanical smoke control system designed in accordance with Section 909 and where the *smoke damper* will interfere with the operation of the smoke control system.
5. *Fire dampers* and *combination fire/smoke dampers* are not required in kitchen and clothes dryer exhaust systems where *dampers* are prohibited by the International Mechanical Code.

Add new text as follows:

717.5.3.1 Continuous upward airflow. Fire dampers and smoke dampers shall not be installed in shafts that are required to maintain a continuous upward airflow path where closure of the damper would result in the loss of the airflow.

Reason:

Exceptions 1.1 and 2 involve subducts used as a substitute for fire and smoke dampers, respectively. Subducts depend on continuous upward airflow in the shaft to function as intended. Fire dampers or smoke dampers installed in the airpath in a manner that would cutoff the upward airflow through the shaft to the exhaust fan at the top of the shaft when the damper closes would negate the effectiveness of the subducts. An example of where this situation might occur is with two offset shafts, one with an exhaust fan on one without, connected together with a horizontal duct.

Section 717.5.3 would require fire and smoke dampers where the interconnecting duct penetrates the walls of each shaft enclosure. But such use would cut off the continuous airflow through the shaft which does not contain the exhaust fan. This proposal resolves that issue by stating that fire and smoke dampers shall not be installed where such installation would result in a loss of this airflow path. From there, since the penetrations are not protected with a fire damper, Section 717.1.2 would require the penetrations to be protected with a through-penetration firestop system.

Additional changes are being proposed to create consistency between the requirements for the subducts in Exceptions 1 and 2 of Section 717.5.3.

This proposal is submitted by the ICC Fire Code Action Committee (FCAC). The FCAC was established by the ICC Board of Directors to pursue opportunities to improve and enhance assigned International Codes with regard to fire safety and hazardous materials in new and existing buildings and facilities and the protection of life and property in wildland urban interface areas. In 2017 the Fire-CAC has held 3 open meetings. In addition, there were numerous conference calls, Regional Work Group and Task Group meetings for the current code development cycle, which included members of the committees as well as any interested parties, to discuss and debate the proposed changes. Related documentation and reports are posted on the FCAC website at: <https://www.iccsafe.org/codes-tech-support/cs/fire-code-action-committee-fcac/>

Cost Impact

The code change proposal will not increase or decrease the cost of construction .

Where ducts are used to create the continuous upwards airflow, penetrations of these ducts into and out of shaft will now be required to be protected with a through-penetration firestop system in lieu of a fire and smoke damper.

Internal ID: 301

FS71-18

IBC: 717.5.2, 717.5.4;

IMC: 607.5.2, 607.5.3

Proponent: Mark Jelinske, representing Self (mjelinske@rmhgroup.com)

2018 International Building Code

Revise as follows:

717.5.2 Fire barriers. Ducts and air transfer openings of *fire barriers* shall be protected with *listed fire dampers* installed in accordance with their listing. Ducts and air transfer openings shall not penetrate enclosures for *interior exit stairways* and *ramps* and *exit passageways*, except as permitted by Sections 1023.5 and 1024.6, respectively.

Exception: *Fire dampers* are not required at penetrations of *fire barriers* where any of the following apply:

1. Penetrations are tested in accordance with ASTM E119 or UL 263 as part of the fire-resistance-rated assembly.
2. Ducts are used as part of an *approved* smoke control system in accordance with Section 909 and where the use of a *fire damper* would interfere with the operation of a smoke control system.
3. Such walls are penetrated by ducted HVAC systems, have a required *fire-resistance rating* of 1 hour or less, are in areas of other than Group H and are in buildings equipped throughout with an *automatic sprinkler system* in accordance with Section 903.3.1.1 or 903.3.1.2. For the purposes of this exception, a ducted HVAC system shall be a duct system for conveying supply, return or exhaust air as part of the structure's HVAC system. Such a duct system shall be constructed of sheet steel not less than No. 26 gage thickness and shall be continuous from the air-handling appliance or equipment to the final branch connection to individual air outlet and inlet terminals. The final duct branches to the air inlets or outlets shall be accordance with Section 603 of the International Mechanical Code.

717.5.4 Fire partitions. Ducts and air transfer openings that penetrate *fire partitions* shall be protected with *listed fire dampers* installed in accordance with their listing.

Exceptions: In occupancies other than Group H, *fire dampers* are not required where any of the following apply:

1. Corridor walls in buildings equipped throughout with an *automatic sprinkler system* in accordance with Section 903.3.1.1 or 903.3.1.2 and the duct is protected as a through penetration in accordance with Section 714.
2. Tenant partitions in *covered and open mall buildings* where the walls are not required by provisions elsewhere in the code to extend to the underside of the floor or roof sheathing, slab or deck above.
3. The duct system is constructed of *approved* materials in accordance with the International Mechanical Code and the duct penetrating the wall complies with all of the following requirements:
 - 3.1. The duct shall not exceed 100 square inches (0.06 m²).
 - 3.2. The duct shall be constructed of steel not less than 0.0217 inch (0.55 mm) in thickness.
 - 3.3. The duct shall not have openings that communicate the *corridor* with adjacent spaces or rooms.
 - 3.4. The duct shall be installed above a ceiling.
 - 3.5. The duct shall not terminate at a wall register in the fire-resistance-rated wall.
 - 3.6. A minimum 12-inch-long (305 mm) by 0.060-inch-thick (1.52 mm) steel sleeve shall be centered in each duct opening. The sleeve shall be secured to both sides of the wall and all four sides of the sleeve with minimum 1¹/₂-inch by 1¹/₂-inch by 0.060-inch (38 mm by 38 mm by 1.52 mm) steel retaining angles. The retaining angles shall be secured to the sleeve and the wall with No. 10 (M5) screws. The *annular space* between the steel sleeve and the wall opening shall be filled with *mineral wool* batting on all sides.
4. Such walls are penetrated by ducted HVAC systems, have a required *fire-resistance rating* of 1 hour or less, and are in buildings equipped throughout with an automatic sprinkler system in

accordance with Section 903.3.1.1 or 903.3.1.2. For the purposes of this exception, a ducted HVAC system shall be a duct system for conveying supply, return or exhaust air as part of the structure's HVAC system. Such a duct system shall be constructed of sheet steel not less than No. 26 gage thickness and shall be continuous from the air-handling appliance or equipment to the final branch connection to individual air outlet and inlet terminals. The final duct branches to the air inlets or outlets shall be accordance with Section 603 of the International Mechanical Code.

2018 International Mechanical Code

Revise as follows:

[BF] 607.5.2 Fire barriers. Ducts and air transfer openings that penetrate fire barriers shall be protected with *listed* fire dampers installed in accordance with their listing. Ducts and air transfer openings shall not penetrate enclosures for interior exit stairways and ramps and exit passageways except as permitted by Sections 1023.5 and 1024.6, respectively, of the International Building Code.

Exception: Fire dampers are not required at penetrations of fire barriers where any of the following apply:

1. Penetrations are tested in accordance with ASTM E119 or UL 263 as part of the fire-resistance-rated assembly.
2. Ducts are used as part of an *approved* smoke control system in accordance with Section 513 and where the fire damper would interfere with the operation of the smoke control system.
3. Such walls are penetrated by ducted HVAC systems, have a required fire-resistance rating of 1 hour or less, are in areas of other than Group H and are in buildings equipped throughout with an automatic sprinkler system in accordance with Section 903.3.1.1 or 903.3.1.2 of the International Building Code. For the purposes of this exception, a ducted HVAC system shall be a duct system for the structure's HVAC system. Such a duct system shall be constructed of sheet steel not less than 26 gage [0.0217 inch (0.55 mm)] thickness and shall be continuous from the air-handling *appliance or equipment* to the final branch connection to individual air outlet and inlet terminals. The final duct branches to the air inlets or outlets shall be accordance with Section 603.

[BF] 607.5.3 Fire partitions. Ducts and air transfer openings that penetrate fire partitions shall be protected with *listed* fire dampers installed in accordance with their listing.

Exception: In occupancies other than Group H, fire dampers are not required where any of the following apply:

1. Corridor walls in buildings equipped throughout with an automatic sprinkler system in accordance with Section 903.3.1.1 or 903.3.1.2 of the International Building Code and the duct is protected as a through penetration in accordance with Section 714 of the International Building Code.
2. The partitions are tenant partitions in covered and open mall buildings where the walls are not required by provisions elsewhere in the International Building Code to extend to the underside of the floor or roof sheathing, slab or deck above.
3. The duct system is constructed of *approved* materials in accordance with Section 603 and the duct penetrating the wall complies with all of the following requirements:
 - 3.1. The duct shall not exceed 100 square inches (0.06 m²).
 - 3.2. The duct shall be constructed of steel not less than 0.0217 inch (0.55 mm) in thickness.
 - 3.3. The duct shall not have openings that communicate the corridor with adjacent spaces or rooms.
 - 3.4. The duct shall be installed above a ceiling.
 - 3.5. The duct shall not terminate at a wall register in the fire-resistance-rated wall.
 - 3.6. A minimum 12-inch-long (305 mm) by 0.060-inch-thick (1.52 mm) steel sleeve shall be centered in each duct opening. The sleeve shall be secured to both sides of the wall and all four sides of the sleeve with minimum 1¹/₂-inch by 1¹/₂-inch by 0.060-inch (38 mm by 38 mm by 1.52 mm) steel retaining angles. The retaining angles shall be secured to the sleeve and the wall with No. 10 (M5) screws. The annular space between the steel sleeve and the wall opening shall be filled with rock (mineral) wool batting on all sides.
4. Such walls are penetrated by ducted HVAC systems, have a required fire-resistance rating of 1 hour or less, and are in areas of other than Group H and are in buildings equipped throughout

with an automatic sprinkler system in accordance with Section 903.3.1.1 or 903.3.1.2 of the International Building Code. For the purposes of this exception, a ducted HVAC system shall be a duct system for conveying supply, return or exhaust air as part of the structure's HVAC system. Such a duct system shall be constructed of sheet steel not less than 26 gage in thickness and shall be continuous from the air-handling appliance or equipment to the final branch connection to individual air outlet and inlet terminals. The final duct branches to the air inlets or outlets shall be accordance with Section 603.

Reason:

The exception as it now stands makes no sense. A 26 ga duct system can have unlimited openings immediately on both sides of a fire barrier or fire partition and not require a fire damper, as long as it continues to the equipment. But as soon as one of those openings has a flexible duct runout to a diffuser, for some reason a damper is required. There is no evidence that connecting a flexible duct to a sheet metal duct opening decreases the fire resistance of a wall penetrated by that duct.

This proposal will eliminate a major source of confusion and varying interpretations. The IBC and IMC commentaries have different interpretations, and a completely different interpretation was received via a staff technical question. Additional different interpretations have been enforced by local jurisdictions. As long as it is acceptable for a sheet metal duct with unlimited openings to penetrate a Fire Barrier or a Fire Partition without a fire damper, there is no reason those openings should not have flex duct on them.

IBC 717.7 prohibits the flexible duct itself from penetrating fire resistive construction.

Cost Impact

The code change proposal will decrease the cost of construction .

Many HVAC systems have flexible duct as the final branch run-out to grilles and diffusers. Under the current code language, these systems are not fully ducted, and therefore require fire dampers. This proposal will reduce the amount of dampers required in such systems in fully sprinklered buildings.

Internal ID: 1768

FS72-18

IBC: 718.2.1

Proponent: Tony Crimi, representing North American Insulation Manufacturers Association (NAIMA) (tcrimi@sympatico.ca)

2018 International Building Code

Revise as follows:

718.2.1 Fireblocking materials. *Fireblocking* shall consist of the following materials:

1. Two-inch (51 mm) nominal lumber.
2. Two thicknesses of 1-inch (25 mm) nominal lumber with broken lap joints.
3. One thickness of 0.719-inch (18.3 mm) wood structural panels with joints backed by 0.719-inch (18.3 mm) wood structural panels.
4. One thickness of 0.75-inch (19.1 mm) particleboard with joints backed by 0.75-inch (19 mm) particleboard.
5. One-half-inch (12.7 mm) gypsum board.
6. One-fourth-inch (6.4 mm) cement-based millboard.
7. Batts or blankets of mineral wool, mineral fiber or other *approved* materials installed in such a manner as to be securely retained in place.
8. Cellulose insulation installed as tested in accordance with ASTM E119 or UL 263 for the specific application.

Reason:

This proposal harmonizes section 718.2.1 of the IBC with R302.11.1 of the IRC. In the 2018 cycle, this proposed language was added to the IRC, but not to the IBC.

The current Code language in the IBC not only lacks acceptance criteria, it also lacks a test method. Therefore, this proposal would ensure that testing of cellulose insulation for use as a fireblocking material is in accordance with ASTM E119 or UL 263. This proposal incorporates the test method identified by the proponents for evaluation of spray-applied cellulose insulation for use as fireblocking.

This clarifies the code requirement in a manner consistent with the language in IBC 718.2.1.3 and IRC R302.11.1.3, and prevents potentially unintended, or unsuitable, test methods from being used for these purposes. The proposal aims to provide more detail to the requirement to test cellulose insulation in accordance with the appropriate fire test standards. For the 2012 cycle, spray-applied cellulose was added to the list of acceptable fireblocking materials. The proponent's statement identified ASTM E119 as the test standard used by the Cellulose Insulation Manufacturers Association (CIMA) to conduct a variety of fireblocking fire tests. However, these Reports are not publicly available, so any modifications to the ASTM E119 procedure, or limitations identified in these reports, are not known.

Cost Impact

The code change proposal will not increase or decrease the cost of construction .

It modifies one option only, and is based on the original supporting information.

Internal ID: 1089

FS73-18

IBC: 718.2.1

Proponent: Stephen DiGiovanni, representing ICC Ad Hoc Committee on Tall Wood Buildings (TWB) (TWB@iccsafe.org)

THIS CODE CHANGE WILL BE HEARD BY THE IBC GENERAL COMMITTEE. SEE THE TENTATIVE HEARING ORDER FOR THIS COMMITTEE.

2018 International Building Code

Revise as follows:

718.2.1 Fireblocking materials. *Fireblocking* shall consist of the following materials:

1. Two-inch (51 mm) nominal lumber.
2. Two thicknesses of 1-inch (25 mm) nominal lumber with broken lap joints.
3. One thickness of 0.719-inch (18.3 mm) wood structural panels with joints backed by 0.719-inch (18.3 mm) wood structural panels.
4. One thickness of 0.75-inch (19.1 mm) particleboard with joints backed by 0.75-inch (19 mm) particleboard.
5. One-half-inch (12.7 mm) gypsum board.
6. One-fourth-inch (6.4 mm) cement-based millboard.
7. Batts or blankets of mineral wool, mineral fiber or other *approved* materials installed in such a manner as to be securely retained in place.
8. Cellulose insulation installed as tested for the specific application.
9. Mass timber complying with Section 2304.11.

Reason:

The Ad Hoc Committee on Tall Wood Buildings (TWB) was created by the ICC Board to explore the science of tall wood buildings and take action on developing code changes for tall wood buildings. The TWB has created several code change proposals with respect to the concept of tall buildings of mass timber and the background information is at the end of this Statement. Within the statement are important links to information, including documents and videos, used in the deliberations which resulted in these proposals.

The purpose of this code change proposal is to recognize that mass timber as a suitable fireblocking material. The current list of acceptable materials lists “nominal lumber”, therefore since mass timber (e.g. Sawn, glued-laminated, and cross laminated timbers) are of greater mass the correlation from single nominal lumber to mass timber was determined to be of equal or greater blocking resistance to reduce the ability of fire, smoke and gasses from moving to different part of the building through combustible concealed spaces.

Background information: The ICC Board approved the establishment of an ad hoc committee for tall wood buildings in December of 2015. The purpose of the ad hoc committee is to explore the science of tall wood buildings and to investigate the feasibility and take action on developing code changes for tall wood buildings. The committee is comprised of a balance of stakeholders with additional opportunities for interested parties to participate in the four Work Groups established by the ad hoc committee, namely: Code; Fire; Standards/Definitions; and Structural. For more information, be sure to visit the ICC website <https://www.iccsafe.org/codes-tech-support/cs/icc-ad-hoc-committee-on-tall-wood-buildings/> (link active and up to date as of 12/27/17). As seen in the “Meeting Minutes and Documents” and “Resource Documents” sections of the committee web page, the ad hoc committee reviewed a substantial amount of information in order to provide technical justification for code proposals.

The ad hoc committee developed proposals for the followings code sections. The committee believes this package of code changes will result in regulations that adequately address the fire and life safety issues of tall mass timber buildings.

IBC Code Section	Description
403.3.2	Water supply requirements for fire pumps in high rise buildings of Type IVA and IVB construction.
504.3	Allowable building height (feet) for buildings of Type IVA, IVB and IVC construction. No changes to Type IV HT construction.
504.4	Allowable building height (stories) for buildings of Type IVA, IVB and IVC construction. No changes to Type IV HT.
506.2	Allowable building area for buildings of Type IVA, IVB and IVC construction. No changes to Type IV HT.
508.4.4.1 509.4.1.1 (new)	Requirements for mass timber building elements serving as fire barriers or horizontal assemblies in buildings of Type IVB or IVC construction.
602.4	Type of Construction requirements for new proposed types of construction: Types IVA, IVB and IVC. No changes to Type IV HT construction. Includes definitions for new terms: Mass timber and Noncombustible protection (mass timber). THIS IS THE KEY CODE CHANGE PROPOSAL WHICH OUTLINES THE CONSTRUCTION REQUIREMENTS FOR THE PROPOSED NEW TYPE OF MASS TIMBER BUILDINGS. THE PROPOSAL ALSO ADDRESSES CONCEALED SPACES, ADHESIVE PERFORMANCE AND EXTERIOR WALL PROTECTION.
703.8 (new)	The performance method to determine the increase to the fire resistance rating provided by noncombustible protection applied to the mass timber building element.
703.9 (new)	Requirements for sealants and adhesives to be placed at abutting edges and intersections of mass timber building elements. The reason statement references a Group B proposal to Chapter 17 for special inspection requirements of sealants and adhesives.
718.2.1	Requirements on the use of mass timber building elements used for Fireblocking.
722.7 (new)	Requirements for the fire resistance rating of mass timber elements, including minimum required protection and gypsum board attachment requirements.
3102	Requirements for membrane structures using Type IV HT construction.
Appendix	Requirements for walls, floors and roofs of Type IV HT construction in buildings located in Fire Districts.
IFC Code Section	Description
701.6	Requirements which stipulate the owner's responsibility to maintain inventory of all required fire resistance rated construction in buildings of Types IVA and IVB construction. This includes an annual inspection and proper repair where necessary.
3308.4 (new)	New special precautions during construction of buildings of Types IVA, IVB and IVC construction: Standpipes; Water supply for fire department connections; Noncombustible protection required for mass timber elements as construction height increases.
Proposed changes to be submitted in 2019 Group B	
IBC Chapter 17	Required special inspections of mass timber construction <ul style="list-style-type: none"> • Structural • Sealants and adhesives (see IBC 703.8)
IBC Chapter 23	An update to referenced standard APA PRG 320 Standard for Performance –rated Cross-laminated Timber which is currently undergoing revision to ensure the adequacy of the adhesives under fire conditions.

In addition, fire tests designed to simulate the three new construction types (Types IVA, IVB and IVC) in the ad hoc committee proposals were conducted at the Alcohol Tobacco and Firearms test lab facility. The TWB was involved in the design of the tests, and many members witnessed the test in person or online. The results of the series of 5 fire tests provide additional support for these proposals, and validate the fire performance for each of the types of construction proposed by the committee. The fire tests consisted of one-bedroom apartments on two levels, with both apartments having a corridor leading to a stair. The purpose of the tests was to address the contribution of mass timber to a fire, the performance of connections, the performance of through-penetration fire stops, and to evaluate conditions for responding fire personnel.

To review a summary of the fire tests, please visit <http://bit.ly/ATF-firetestreport>

To watch summary videos of the fire tests, please visit <http://bit.ly/ATF-firetestvideos>

Both of these links were confirmed active on 12/27/17.

Cost Impact

The code change proposal will not increase or decrease the cost of construction .

This section provides information that was not previously set forth in the code, and does not change the requirements of current code, thus there is no cost impact when compared with present requirements.

Internal ID: 944

FS74-18

IBC: 718.2.6, 1402.5, 1408.10.4, 2603.5.5, Chapter 35

Proponent: JC Harrington, FM Global, representing FM Global (john.harrington@fmglobal.com)

2018 International Building Code

Revise as follows:

718.2.6 Exterior wall coverings. *Fireblocking* shall be installed within concealed spaces of exterior wall coverings and other exterior architectural elements where permitted to be of combustible construction as specified in Section 1405 or where erected with combustible frames. *Fireblocking* shall be installed at maximum intervals of 20 feet (6096 mm) in either dimension so that there will be no concealed space exceeding 100 square feet (9.3 m²) between *fireblocking*. Where wood furring strips are used, they shall be of *approved* wood of natural decay resistance or preservative-treated wood. If noncontinuous, such elements shall have closed ends, with not less than 4 inches (102 mm) of separation between sections.

Exceptions:

1. *Fireblocking* of cornices is not required in single-family dwellings. *Fireblocking* of cornices of a two-family dwelling is required only at the line of dwelling unit separation.
2. *Fireblocking* shall not be required where the exterior wall covering is installed on noncombustible framing and the face of the exterior wall covering exposed to the concealed space is covered by one of the following materials:
 - 2.1. Aluminum having a minimum thickness of 0.019 inch (0.5 mm).
 - 2.2. Corrosion-resistant steel having a base metal thickness not less than 0.016 inch (0.4 mm) at any point.
 - 2.3. Other *approved* noncombustible materials.
3. *Fireblocking* shall not be required where the exterior wall covering has been tested in accordance with, and complies with the acceptance criteria of, NFPA 285, or the 16 foot parallel panel test as described in ANSI/FM 4880. The exterior wall covering shall be installed as tested in accordance with NFPA 285, or the 16 foot parallel panel test per ANSI/FM 4880.

1402.5 Vertical and lateral flame propagation. *Exterior walls* on buildings of Type I, II, III or IV construction that are greater than 40 feet (12 192 mm) in height above grade plane and contain a combustible *water-resistive barrier* shall be tested in accordance with and comply with the acceptance criteria of NFPA 285, or the 16 foot (4877 mm) parallel panel test as described in ANSI/FM 4880. For the purposes of this section, *fenestration* products, flashing of *fenestration* products and *water-resistive-barrier* flashing and accessories at other locations, including through wall flashings, shall not be considered part of the *water-resistive barrier*.

Exceptions:

1. Walls in which the *water-resistive barrier* is the only combustible component and the *exterior wall* has a wall covering of brick, concrete, stone, terra cotta, stucco or steel with minimum thicknesses in accordance with Table 1404.2.
2. Walls in which the *water-resistive barrier* is the only combustible component and the *water-resistive barrier* has a peak heat release rate of less than 150 kW/m², a total heat release of less than 20 MJ/m² and an effective heat of combustion of less than 18 MJ/kg as determined in accordance with ASTM E1354 and has a flame spread index of 25 or less and a smoke-developed index of 450 or less as determined in accordance with ASTM E84 or UL 723. The ASTM E1354 test shall be conducted on specimens at the thickness intended for use, in the horizontal orientation and at an incident radiant heat flux of 50 kW/m².

1408.10.4 Full-scale tests. The HPL system shall be tested in accordance with, and comply with, the acceptance criteria of either NFPA 285 or the 16 foot parallel panel test as described in ANSI/FM 4880. Such testing shall be performed on the HPL system with the HPL in the minimum and maximum thicknesses intended for use.

2603.5.5 Vertical and lateral fire propagation. The exterior wall assembly shall be tested in accordance with and comply with the acceptance criteria of either NFPA 285 or the 16 foot parallel panel test as described in ANSI/FM 4880.

Exceptions:

1. One-story buildings complying with Section 2603.4.1.4.
2. Wall assemblies where the foam plastic insulation is covered on each face by not less than 1-inch (25 mm) thickness of masonry or concrete and meeting one of the following:
 - 2.1. There is no airspace between the insulation and the concrete or masonry.
 - 2.2. The insulation has a flame spread index of not more than 25 as determined in accordance with ASTM E84 or UL 723 and the maximum airspace between the insulation and the concrete or masonry is not more than 1 inch (25 mm).

Update standard(s) as follows:

CHAPTER 35 REFERENCED STANDARDS

FM

FM Approvals
Headquarters Office 1151 Boston-
Providence Turnpike P.O. Box 9102
Norwood MA 02062

4880-2015~~2017~~:

Approval Standard for Class 1 Fire Rating of Building Panels or Interior Finish Materials

Reason:

ANSI/FM 4880 is a consensus fire test standard that can be used to test fire exposure to the interior side or exterior side of exterior walls. The 16 ft parallel panel test is described in ANSI/FM 4880. The 16 ft parallel panel test as an alternative to the NFPA 285 test will not result in a related cost increase.

Bibliography:

Agarwal, Gaurav, "Evaluation of the Fire Performance of Aluminum Composite Material (ACM) Assemblies using ANSI/FM 4880, FM Global Research Technical Report, December 20017.

Nam,Soonil and Bill, Robert G Jr. "A New Intermediate-scale Fire Test for Evaluating Building Material Flammability", SFPE Journal of Fire Protection Engineering, Feb 2009

Cost Impact

The code change proposal will not increase or decrease the cost of construction .

The proposal offers another method to determine use of the exception. No affect on cost of construction.

Analysis: A review of the standard proposed for inclusion in the code, FM 4880-2017, with regard to the ICC criteria for referenced standards (Section 3.6 of CP#28) will be posted on the ICC website on or before April 2, 2018. The 2015 edition of the standard is currently referenced. This proposal increases the use of the standard as well as proposes to go to the 2017 edition.

Internal ID: 1868

FS75-18

IBC: TABLE 721.1(1), 722.2.3.1

Proponent: Ali Fattah, City of San Diego, representing City of San Diego (afattah@sandiego.gov)

2018 International Building Code

Revise as follows:

TABLE 721.1(1)

MINIMUM PROTECTION OF STRUCTURAL PARTS BASED ON TIME PERIODS FOR VARIOUS NONCOMBUSTIBLE INSULATING MATERIALS^m

Portions of table not shown remain unchanged.

STRUCTURAL PARTS TO BE PROTECTED	ITEM NUMBER	INSULATING MATERIAL USED	MINIMUM THICKNESS OF INSULATING MATERIAL FOR THE FOLLOWING FIRE-RESISTANCE PERIODS (inches)			
			4 hours	3 hours	2 hours	1 hour
4. Bonded or unbonded post-tensioned tendons in pre-stressed concrete ^e .	4-1.1	Carbonate, lightweight, sand-lightweight and siliceous ^f aggregate concrete Unrestrained members: Solid slabs ^h <u>See Section 722.2.3.3.1 as well as Table 722.2.3(2)</u> Beams and girders [†] 8" wide greater than 12" wide	—	2	1 ³ / ₂	—
	4-1.2	<u>See Section 722.2.3.3.1 as well as Table 722.2.3(2)</u> Carbonate, lightweight, sand-lightweight and siliceous aggregate Restrained members: ^k Solid slabs ^h Beams and girders [†] 8" wide greater than 12" wide	1 ³ / ₄	1	3 ³ / ₄	—
			2 ¹ / ₂	2	1 ³ / ₄	—
			2	1 ³ / ₄	1 ¹ / ₂	—

For SI: 1 inch = 25.4 mm, 1 square inch = 645.2 mm², 1 cubic foot = 0.0283 m³, 1 pound per cubic foot = 16.02 kg/m³.

- a. Reentrant parts of protected members to be filled solidly.
- b. Two layers of equal thickness with a ³/₄-inch airspace between.
- c. For all of the construction with gypsum wallboard described in Table 721.1(1), gypsum base for veneer plaster of the same size, thickness and core type shall be permitted to be substituted for gypsum wallboard, provided that attachment is identical to that specified for the wallboard and the joints on the face layer are reinforced, and the entire surface is covered with not less than ¹/₁₆-inch gypsum veneer plaster.
- d. An approved adhesive qualified under ASTM E119 or UL 263.
- e. Where lightweight or sand-lightweight concrete having an oven-dry weight of 110 pounds per cubic foot or less is used, the tabulated minimum cover shall be permitted to be reduced 25 percent, except that the reduced cover shall be not less than ³/₄ inch in slabs or 1¹/₂ inches in beams or girders.
- f. For solid slabs of siliceous aggregate concrete, increase tendon cover 20 percent.
- g. Adequate provisions against spalling shall be provided by U-shaped or hooped stirrups spaced not to exceed the depth of the member with a clear cover of 1 inch.
- h. Prestressed slabs shall have a thickness not less than that required in Table 721.1(3) for the respective fire-resistance time period.
- i. Fire coverage and end anchorages shall be as follows: Cover to the prestressing steel at the anchor shall be ¹/₂ inch greater than that required away from the anchor. Minimum cover to steel-bearing plate shall be 1 inch in beams and ³/₄ inch in slabs.
- j. For beam widths between 8 inches and 12 inches, cover thickness shall be permitted to be determined by interpolation.
- k. Interior spans of continuous slabs, beams and girders shall be permitted to be considered restrained.
- l. For use with concrete slabs having a comparable fire endurance where members are framed into the structure in such a manner as to provide equivalent performance to that of monolithic concrete construction.
- m. Generic fire-resistance ratings (those not designated as PROPRIETARY* in the listing) in GA 600 shall be accepted as if herein listed.
- n. Additional insulating material is not required on the exposed outside face of the column flange to achieve a 1-hour fire-resistance rating.

722.2.3.1 Slab cover. The minimum thickness of concrete cover to the positive moment reinforcement shall comply with Table 722.2.3(1) for reinforced concrete and Table 722.2.3(2) for prestressed concrete. These tables are applicable for solid or hollow-core one-way or two-way slabs with flat undersurfaces. These tables are applicable to slabs that are either cast in place or precast. For precast prestressed concrete not covered elsewhere, the procedures contained in PCI MNL 124 shall be acceptable. Interior spans of continuous slabs, beams, and girders shall be permitted to be considered restrained. The required positive reinforcing shall be provided along the full length of the continuous tendon.

Reason:

The proposed code change addresses a conflict in the IBC between the prescriptive fire resistance Tables for post tensioned concrete slabs in Table 721.1(1) and prescriptive tables in Section 722. Section 721 is intended to be prescriptive in nature where fire resistance is established based on reinforcing cover protecting post tensioned cables in slabs. Post tensioned cables are more temperature sensitive than mild solid reinforcing bars used in reinforced concrete slabs. Pre-stressed concrete is generally pre-cast concrete and is generally unrestrained. Various organizations such as the American Concrete Institute (ACI) and the Post-Tensioning Institute (PTI) consider cast in place post tensioned concrete to be pre-stressed concrete and as a result item #4 is labeled differently than my description.

Section 722 provides a calculated method for determining the fire resistance of various structural elements including PRESTRESSED CONCRETE FLOOR OR ROOF SLABS . A comparison of the reinforcing covers in Table 721.1(1) item # 4 with the required cover in Table 722.2.3(2) reveals that in many cases the second table is less restrictive and requires less reinforcing cover. Section 722.1 reference concrete standard ACI 216.1/TMS 0216 "Code Requirements for Determining Fire Resistance of Concrete and Masonry Construction Assemblies" and after researching the issue further

it became clear that Table 722.2.3(2) was adopted through transcription from Table 4.3.1.1 for pre-stressed slabs.

The differences in the tables occur with fire resistance ratings of 3 hours and higher for un-restrained and restrained slabs. Additionally, Table 4.3.1 of the ACI standard idealizes all cast in place slabs as restrained whereas footnote k in Table 721.1(1) states that " k. Interior spans of continuous slabs, beams and girders shall be permitted to be considered restrained." Section 722.2.3 is silent on restraint and Section 703.2.3 generically discuss restrained vs unrestrained and throws it on to the design professional to demonstrate a restrained condition.

The proposed code change seeks to modify item # 4-1.1 solid slabs to add a reference to Section 722.2.3.3.1 and Table 722.2.3.3(2) and strikes the covers required for solid slabs. Additionally, the proposed code change copies the text from Table 721.1(1) footnote K and adds the text to Section 722.2.3.1. Reinforcing tendons are continuous over several spans and as a result the required fire resistive cover bottom shall be required along the full length of the tendon.

Very few code users determine fire resistance in new buildings with post tensioned concrete slabs based on calculation and as a consequence this code change harmonizes the required covers for unrestrained pre-stressed or post tensioned concrete slabs.

The proposed code change can be considered editorial in nature.

Bibliography:

ACI/TMS 216.1-14 Code Requirements for Determining Fire Resistance of Concrete and Masonry Construction Assemblies, Chapter 4 https://www.concrete.org/Portals/0/Files/PDF/Previews/216_1-14.PREVIEW.pdf

The link was established on January 11, 2018

Cost Impact

The code change proposal will not increase or decrease the cost of construction .

The proposed code change is editorial in nature and corrects a code conflict.

Internal ID: 926

FS76-18

IBC: TABLE 721.1(3)

Proponent: Tim Earl, representing The Gypsum Association (tearl@gbhinternational.com)

2018 International Building Code

Revise as follows:

TABLE 721.1(3)
MINIMUM PROTECTION FOR FLOOR AND ROOF SYSTEMS^{a, q}

Portions of table not shown remain unchanged.

FLOOR OR ROOF CONSTRUCTION	ITEM NUMBER	CEILING CONSTRUCTION	THICKNESS OF FLOOR OR ROOF SLAB (inches)				MINIMUM THICKNESS OF CEILING (inches)			
			4 hours	3 hours	2 hours	1 hour	4 hours	3 hours	2 hours	1 hour
5. Reinforced concrete	5-1.1	Slab with suspended ceiling of vermiculite gypsum plaster over metal lath attached to 3/4" cold-rolled channels spaced 12" on center. Ceiling located 6" minimum below joists.	3	2	—	—	1	3/4	—	—
	5-2.1	3/8" x 5/8" Type X gypsum wallboard ^c attached to 0.018 inch (No. 25 carbon sheet steel gage) by 7/8" deep by 2 5/8" hat-shaped galvanized steel channels with 1"-long No. 6 screws. The channels are spaced 24" on center, span 35" and are supported along their length at 35" intervals by 0.033" (No. 21 galvanized sheet gage) galvanized steel flat strap hangers having formed edges that engage the lips of the channel. The strap hangers are attached to the side of the concrete joists with 5/32" by 1 1/4" long power-driven fasteners. The wallboard is installed with the long dimension perpendicular to the channels. End joints occur on channels and supplementary channels are installed parallel to the main channels, 12" each side, at end joint occurrences. The finished ceiling is located approximately 12" below the soffit of the floor slab.	—	—	2 1/2	—	—	—	5/8	—

For SI: 1 inch = 25.4 mm, 1 foot = 304.8 mm, 1 pound = 0.454 kg, 1 cubic foot = 0.0283 m³,

1 pound per square inch = 6.895 kPa, 1 pound per linear foot = 1.4882 kg/m.

- a. Staples with equivalent holding power and penetration shall be permitted to be used as alternate fasteners to nails for attachment to wood framing.
- b. Where the slab is in an unrestrained condition, minimum reinforcement cover shall be not less than $1\frac{5}{8}$ inches for 4 hours (siliceous aggregate only); $1\frac{1}{4}$ inches for 4 and 3 hours; 1 inch for 2 hours (siliceous aggregate only); and $\frac{3}{4}$ inch for all other restrained and unrestrained conditions.
- c. For all of the construction with gypsum wallboard described in this table, gypsum base for veneer plaster of the same size, thickness and core type shall be permitted to be substituted for gypsum wallboard, provided that attachment is identical to that specified for the wallboard, and the joints on the face layer are reinforced and the entire surface is covered with not less than $\frac{1}{16}$ -inch gypsum veneer plaster.
- d. Slab thickness over steel joists measured at the joists for metal lath form and at the top of the form for steel form units.
- e.
 - (a) The maximum allowable stress level for H-Series joists shall not exceed 22,000 psi.
 - (b) The allowable stress for K-Series joists shall not exceed 26,000 psi, the nominal depth of such joist shall be not less than 10 inches and the nominal joist weight shall be not less than 5 pounds per linear foot.
- f. Cement plaster with 15 pounds of hydrated lime and 3 pounds of approved additives or admixtures per bag of cement.
- g. Gypsum wallboard ceilings attached to steel framing shall be permitted to be suspended with $1\frac{1}{2}$ -inch cold-formed carrying channels spaced 48 inches on center, that are suspended with No. 8 SWG galvanized wire hangers spaced 48 inches on center. Cross-furring channels are tied to the carrying channels with No. 18 SWG galvanized wire hangers spaced 48 inches on center. Cross-furring channels are tied to the carrying channels with No. 18 SWG galvanized wire (double strand) and spaced as required for direct attachment to the framing. This alternative is applicable to those steel framing assemblies recognized under Note q.
- h. Six-inch hollow clay tile with 2-inch concrete slab above.
- i. Four-inch hollow clay tile with $1\frac{1}{2}$ -inch concrete slab above.
- j. Thickness measured to bottom of steel form units.
- k. Five-eighths inch of vermiculite gypsum plaster plus $\frac{1}{2}$ inch of approved vermiculite acoustical plastic.
- l. Furring channels spaced 12 inches on center.
- m. Double wood floor shall be permitted to be either of the following:
 - (a) Subfloor of 1-inch nominal boarding, a layer of asbestos paper weighing not less than 14 pounds per 100 square feet and a layer of 1-inch nominal tongue-and-groove finished flooring.
 - (b) Subfloor of 1-inch nominal tongue-and-groove boarding or $\frac{15}{32}$ -inch wood structural panels with exterior glue and a layer of 1-inch nominal tongue-and-groove finished flooring or $\frac{19}{32}$ -inch wood structural panel finish flooring or a layer of Type I Grade M-1 particleboard not less than $\frac{5}{8}$ -inch thick.
- n. The ceiling shall be permitted to be omitted over unusable space, and flooring shall be permitted to be omitted where unusable space occurs above.
- o. For properties of cooler or wallboard nails, see ASTM C514, ASTM C547 or ASTM F1667.
- p. Thickness measured on top of steel deck unit.
- q. Generic fire-resistance ratings (those not designated as PROPRIETARY* in the listing) in the GA 600 shall be accepted as if herein listed.

Reason:

This is a typo. $\frac{3}{8}$ " type X boards are not readily commercially available. Generic $\frac{5}{8}$ " type X boards are readily available in the market. This change simply fixes this.

Cost Impact

The code change proposal will not increase or decrease the cost of construction .

This change simply corrects a typo, which will not affect construction costs.

Internal ID: 238

FS77-18

IBC: 722.1, 722.2.3.1, Chapter 35

Proponent: Stephen Skalko, Stephen V. Skalko, P.E. & Associates, LLC, representing Stephen V. Skalko, P.E. & Associates, LLC (svskalko@svskalko-pe.com); Jason Krohn, representing Precast/Prestressed Concrete Institute (jkrohn@pci.org)

2018 International Building Code

Revise as follows:

722.1 General. The provisions of this section contain procedures by which the *fire resistance* of specific materials or combinations of materials is established by calculations. These procedures apply only to the information contained in this section and shall not be otherwise used. The calculated *fire resistance* of ~~concrete-specific materials or~~ combinations of materials shall be established by one of the following:

1. Concrete, concrete masonry and clay masonry assemblies shall be permitted in accordance with ACI 216.1/TMS 0216.
2. Precast and precast, prestressed concrete assemblies shall be permitted in accordance with PCI 124.
3. ~~The calculated fire resistance of~~ Steel assemblies shall be permitted in accordance with Chapter 5 of ASCE 29.
4. ~~The calculated fire resistance of~~ Exposed wood members and wood decking shall be permitted in accordance with Chapter 16 of ANSI/AWC National Design Specification for Wood Construction (NDS).

722.2.3.1 Slab cover. The minimum thickness of concrete cover to the positive moment reinforcement shall comply with Table 722.2.3(1) for reinforced concrete and Table 722.2.3(2) for prestressed concrete. These tables are applicable for solid or hollow-core one-way or two-way slabs with flat undersurfaces. These tables are applicable to slabs that are either cast in place or precast. For precast prestressed concrete not covered elsewhere, the procedures contained in PCI ~~MNL-124~~ shall be acceptable.

Update standard(s) as follows:

PCI

Precast Prestressed Concrete
Institute
200 West Adams Street, Suite 2100
Chicago IL 60606-6938
US

~~MNL-PCI 124-1118:~~

~~Design Specification for Fire Resistance of Precast Prestressed Concrete~~

Reason:

PCI MNL 124 was one of the first stand-alone technical documents developed for calculating the fire resistance of precast, prestressed concrete elements. The first edition was published in 1977 and was referenced in the legacy codes. The publication was updated in 1989 and again in 2011. It has been referenced in the International Building Code since the first edition of the IBC in 2000 with the 2011 edition referenced in the 2015 edition of the IBC. To make the document more useful to the design and code enforcement community, PCI has undertaken another revision to separate out code enforceable language from commentary and reformat the publication following ANSI-accredited standard development procedures.

PCI 124-18 is now a PCI consensus standard that provides a calculation method for determining the fire resistance of precast and precast, prestressed concrete elements and assemblies. In Section 722.2.3.1 PCI MNL 124 is presently referenced in the IBC for use in determining the cover to reinforcement in precast prestressed slabs. PCI 124-18 however also has provisions for determining the fire resistance for precast and precast, prestressed members and assemblies beyond just reinforcement cover for slabs.

This proposed code change adds PCI 124-18 to the list of acceptable calculation procedures in Section 722.1 for all precast and precast, prestressed concrete, not just slabs. The code change also formats the section to list individually all the acceptable calculation methods for concrete, masonry, steel and wood elements and assemblies.

Listing the methods in this manner will help the code user easily identify these methods the code allows to be used under Section 722.

Cost Impact

The code change proposal will not increase or decrease the cost of construction .

PCI 124 is the updated version of MNL 124, which is presently referenced in the IBC. But, PCI 124 is developed through an ANSI accredited consensus process, including using mandatory language for ease of enforcement. Code users who applied MNL 124 for determining fire resistance of precast and precast-prestressed concrete elements previously will be applying the same concepts to establish the fire resistances, thus the cost of construction should remain unchanged.

Analysis: A review of the standard proposed for inclusion in the code, PCI 124-18, with regard to the ICC criteria for referenced standards (Section 3.6 of CP#28) will be posted on the ICC website on or before April 2, 2018. Under a previous number, MNL 124, this standard is already referenced. This proposal expands the use of the standard by reference and updates the number.

Internal ID: 1539

FS78-18

IBC: 722.2.3

Proponent: Michael Hill, representing Self

2018 International Building Code

Revise as follows:

722.2.3 Concrete cover over reinforcement. The minimum thickness of concrete cover over reinforcement in concrete slabs, reinforced beams and prestressed beams shall comply with this section. The structural capacity of concrete slabs, reinforced beams and prestressed beams at elevated temperatures shall be determined by calculation.

Reason:

Many engineers, architects and building officials do not fully understand the difference between the tables in sections 721 and 722. The proposed addition of text to this section will reinforce the requirement for the design professional to determine the capacity of the concrete members at elevated temperatures by engineering calculations.

Cost Impact

The code change proposal will not increase or decrease the cost of construction .

Clarification only

Internal ID: 1371

FS79-18

IBC: 722.2.2.1.4 (New)

Proponent: Amy Trygestad, Concrete Reinforcing Steel Institute, representing Concrete Reinforcing Steel Institute (atrygestad@crsi.org); William Hall, Portland Cement Association, representing Alliance For Concrete Codes and Standards (jhall@cement.org); Stephen Szoke, American Concrete Institute, representing American concrete Institute (steve.szoke@concrete.org)

2018 International Building Code

Add new text as follows:

722.2.2.1.4 Flat plate concrete slabs with uniformly spaced hollow voids. Table 722.2.2.1 shall be used to determine the fire-resistance of 1 hour and 2 hours for flat plate concrete slabs with uniformly spaced hollow voids. The equivalent thickness of the slab shall be determined by dividing the net concrete volume of the slab by the floor area. The net concrete volume of the slab shall be equal to the volume of concrete of a solid slab minus the average concrete volume displaced by the hollow voids.

Reason:

The proposed subsection is to include prescriptive fire-resistance rating for flat plate concrete slabs with uniformly spaced hollow voids based on equivalent thickness.

In general, the equivalent thickness of a flat plate concrete slab with uniformly spaced hollow voids is equal to the net volume of concrete divided by the floor area. IBC Table 722.2.2.1 provides minimum slab thickness of reinforced concrete floor and roof assemblies to achieve fire-resistance ratings based on aggregate type. Flat plate concrete slabs with uniformly spaced hollow voids are similar to slabs with ribbed or undulating soffits, so an equivalent slab thickness must be calculated for use in Table 722.2.2.1.

To verify the system fire-resistance rating, a voided slab assembly was tested in accordance with the requirements of ASTM E119 in June 2017. The test assembly consisted of an 8-in.-thick normalweight concrete slab with siliceous aggregate, a design compressive strength of 5,000psi, and a cover of 3/4 in. to the main flexural reinforcing bars. The equivalent thickness was 5.9 in, calculated using the net concrete volume of the slab divided by the slab area. The edge of the slab on all 4 sides were supported vertically by the test frame, no restraint was provided for thermal expansion or rotation. As such, the assembly was unrestrained during the duration of the fire test, which is conservative for cast-in-place concrete slab systems.

The ASTM E119 test was terminated when the assembly reached the heat transmission end point at 2 hours 51 minutes, corresponding to a 2-hour fire-resistance rating. Throughout the duration of the test, the assembly supported the applied loading with no signs of collapse. Thus, the fire-resistance rating based on equivalent thickness is essentially the same as that determined from the fire test. The test is documented in the Test Report FC-891_R1.

In addition, numerous fire tests have been performed on similar voided slab assemblies in accordance with the provisions in Fire Behavior of Building Materials and Building Components; Definitions, Requirements and Tests (DIN 4102-02). The time-temperature curve used to test assemblies in the DIN requirements is essentially the same as that prescribed in Fire-Resistance Test - Elements of Building Construction - Part 1: General Requirements (ISO 834). ISO834 and ASTM E119 time-temperature curves are also essentially the same, and it has been shown that the differences in severity between the two tests are negligible.

Bibliography:

Test Report for Steel Reinforced Concrete Slab with Low Profile Recycled Plastic Voids , Test Report No. FC-891_R1, NGC Testing Services for Concrete Reinforcing Steel Institute, 2017

Cost Impact

The code change proposal will not increase or decrease the cost of construction .

This is an optional fire-rated assembly available for use.

Internal ID: 655

FS80-18

IBC: TABLE 722.6.2(5)

Proponent: Rick Roos, representing Rockwool (richard.roos@roxul.com)

2018 International Building Code

Revise as follows:

**TABLE 722.6.2(5)
TIME ASSIGNED FOR ADDITIONAL PROTECTION**

DESCRIPTION OF ADDITIONAL PROTECTION	FIRE RESISTANCE (minutes)
<p>Add to the fire-resistance rating of wood stud walls if the spaces between the studs are completely filled with glass fiber mineral wool batts weighing not less than 2 pounds per cubic foot (0.6 pound per square foot of wall surface) or rockwool or slag material wool batts weighing not less than 3.3 pounds per cubic foot (1 pound per square foot of wall surface), or cellulose insulation having a normal density not less than 2.5 pounds per cubic foot.</p>	<p align="center">15</p>
<p><u>Add to the fire-resistance rating of wood stud walls if the spaces between the studs are completely filled with mineral wool batts weighing not less than 0.86 pounds per cubic foot (0.25 pounds per square foot of wall surface).</u></p>	<p align="center">15</p>
<p><u>Add to the fire-resistance rating of wood stud walls if spaces between the studs are completely filled with glass fiber batts weighing not less than 0.42 pounds per cubic foot (0.12 pounds per square foot of wall surface).</u></p>	<p align="center">5</p>
<p><u>Add to the fire-resistance rating of wood stud walls if the spaces between the</u></p>	<p align="center">10</p>

studs are completely filled with cellulose insulation having a nominal density of not less than 3.12 pounds per cubic foot (0.91 pounds per square foot of wall surface.

For SI: 1 pound/cubic foot = 16.0185 kg/m³.

Reason:

This proposal aims to update Table 722.2.2(5) based on the most recent fire performance research data available. Research undertaken at the National Research Council of Canada involving over 20 new fire resistance tests of wall assemblies in accordance with the methodology of ASTM E119 and led the National Building Code of Canada (NBC) to differentiate between these three insulation materials. The calculation method for wood and steel light-frame construction, was introduced into the 1965 edition of the NBC and was based on fire test reports dated between 1932 and 1962. Like the US Building Codes, many of the original values were based on fire-resistance data generated over four decades ago on typical wall assemblies for that time. Subsequently, additional fire testing research was performed using construction materials, products and techniques that are currently in use. This provided many new insights into the fire resistance of current light-frame assemblies. Four major consortium projects on the fire resistance of wall (load and non-loadbearing) and floor/ceiling assemblies have been completed in recent years, as well as other smaller or related projects, providing data supporting the update and expansion of this Code. with new material and assemblies of materials, including new structural members. This also lead to revisions to the minimum density of insulation materials required to achieve these performance levels. This proposal is consistent with the current Canadian Building Code (NBC) as seen in the excerpt attached to this proposal.

Glass fiber, cellulose and mineral wool insulation materials have dramatically different high temperature performance. Glass fiber melts at 1050°F and mineral wool melts at a temperature of 2080°F, as shown in the image below. Cellulose fiber is made from wood fibers and is treated with flame retardants, and although combustible, it has more of an ability to stay in place than glass fiber insulation, which softens and melts, causing it to sag and create large voids between studs. This renders it ineffective as the fire exposure proceeds to higher temperatures.

Glass fiber insulation has been proven to have substantially less contribution to fire resistance than mineral wool and cellulose insulation. It contributes **only 5 minutes** toward the contribution to the overall fire resistance duration of wood stud wall assemblies. Cellulose has significantly more contribution than glass fiber insulation, providing **10 minutes** additional protection to wood stud wall systems.

In contrast, Mineral wool insulation contributes **15 minutes** toward the overall fire resistance of wood stud wall assemblies.

Excerpt from NBC Component Additive Method

Table D-2.3.4.-G
Time Assigned for Additional Protection

Description of Additional Protection	Time, min
Add to the fire-resistance rating of wood stud walls, sheathed with gypsum board or lath and plaster, if the spaces between the studs are filled with preformed insulation of rock or slag fibres conforming to CAN/ULC-S702, "Mineral Fibre Thermal Insulation for Buildings," and with a mass per unit area of not less than 1.22 kg/m ² of wall surface	15 ⁽¹⁾
Add to the fire-resistance rating of non-loadbearing wood stud walls, sheathed with gypsum board or lath and plaster, if the spaces between the studs are filled with preformed insulation of glass fibres conforming to CAN/ULC-S702, "Mineral Fibre Thermal Insulation for Buildings," and having a mass per unit area of not less than 0.6 kg/m ² of wall surface	5 ⁽²⁾
Add to the fire-resistance rating of loadbearing wood stud walls sheathed with gypsum board if the spaces between the studs are filled with insulation of cellulose fibres conforming to CAN/ULC-S703, "Cellulose Fibre Insulation for Buildings," and having a density of not less than 50 kg/m ³	10
Add to the fire-resistance rating of plaster on gypsum lath ceilings if 0.76 mm diam wire mesh with 25 mm by 25 mm openings or 1.57 mm diam diagonal wire reinforcing at 250 mm o.c. is placed between lath and plaster	30
Add to the fire-resistance rating of plaster on gypsum lath ceilings if 76 mm wide metal lath strips are placed over joints between lath and plaster	10
Add to the fire-resistance rating of plaster on 9.5 mm thick gypsum lath ceilings (Table D-2.3.4.-D) if supports for lath are 300 mm o.c.	10
Add to the fire-resistance rating of floor assemblies if the spaces between the structural members are filled with preformed insulation of rock or slag fibres conforming to CAN/ULC-S702, "Mineral Fibre Thermal Insulation for Buildings," and having a mass per unit area of not less than 1.22 kg/m ² of floor surface	5 ⁽²⁾
Add to the fire-resistance rating of floor assemblies if the spaces between the structural members are filled with wet-blown cellulose fibres conforming to CAN/ULC-S703, "Cellulose Fibre Insulation for Buildings," and having a density of not less than 50 kg/m ³	5 ⁽²⁾⁽³⁾
Add to the fire-resistance rating of floor assemblies where the floor topping on the unexposed side of the floor assemblies consists of concrete not less than 38 mm thick	5 ⁽²⁾

Notes to Table D-2.3.4.-G:

- (1) Applies to wood-framed walls only.
- (2) Applies to wood joists, wood trusses, wood I-joists and cold-formed-steel joists (C-shaped joists).
- (3) Applies to cellulose fibre:
 - (i) for wood joists, wood I-joist and wood trusses—that is spray-applied with a minimum density of 50 kg/m³, a minimum depth of 90 mm on the underside of the subfloor, and of 90 mm on the sides of the structural members;
 - (ii) for cold-formed-steel joists—that is spray-applied with a minimum density of 50 kg/m³ and a minimum thickness of 90 mm on the underside of the subfloor, of 90 mm on the sides of the structural members, and of 13 mm on the underside of the bottom flange other than at resilient metal channel locations.

Bibliography:

2015 National Building Code of Canada - Division B, D-15

Cost Impact

The code change proposal will not increase or decrease the cost of construction .

This proposal updates the Code to provide several options. The cost impact will ultimately depend on the choice of materials and the fire resistance rated assembly components.

Internal ID: 2103

FS81-18

IBC: 722.7 (New), 722.7.1 (New), TABLE 722.7.1(1) (New), TABLE 722.7.1(2) (New), 722.7.2 (New), 722.7.2.1 (New), 722.7.2.2 (New)

Proponent: Stephen DiGiovanni, representing ICC Ad Hoc Committee on Tall Wood Buildings (TWB) (TWB@iccsafe.org)

THIS CODE CHANGE WILL BE HEARD BY THE IBC GENERAL COMMITTEE. SEE THE TENTATIVE HEARING ORDER FOR THIS COMMITTEE.

2018 International Building Code

Add new text as follows:

722.7 Fire resistance rating of mass timber. The required fire resistance of mass timber elements in Section 602.4 shall be determined in accordance with Section 703.2 or Section 703.3. The fire resistance rating of building elements shall be as required in Tables 601 and 602 and as specified elsewhere in this code. The fire resistance rating of the mass timber elements shall consist of the fire resistance of the unprotected element added to the protection time of the noncombustible protection.

722.7.1 Minimum required protection. Where required by Sections 602.4.1 through 602.4.3, noncombustible protection shall be provided for mass timber building elements in accordance with Table 722.7.1(1). The rating, in minutes, contributed by the noncombustible protection of mass timber building elements, components, or assemblies, shall be established in accordance with Section 703.8. The protection contributions indicated in Table 722.7.1(2) shall be deemed to comply with this requirement when installed and fastened in accordance with Section 722.7.2.

TABLE 722.7.1(1)
PROTECTION REQUIRED FROM NONCOMBUSTIBLE COVERING MATERIAL

<u>Required Fire Resistance Rating of Building Element per Tables 601 and 602 (hours)</u>	<u>Minimum Protection Required from Noncombustible Protection (minutes)</u>
<u>1</u>	<u>40</u>
<u>2</u>	<u>80</u>
<u>3 or more</u>	<u>120</u>

**TABLE 722.7.1(2)
PROTECTION PROVIDED BY NONCOMBUSTIBLE COVERING MATERIAL**

Noncombustible Protection	Protection Contribution (minutes)
<u>1/2 inch Type X Gypsum Board</u>	<u>30</u>
<u>5/8 inch Type X Gypsum Board</u>	<u>40</u>

722.7.2 Installation of gypsum board noncombustible protection. Gypsum board complying with Table 722.7.1(2) shall be installed in accordance with this section.

722.7.2.1 Interior surfaces. Layers of Type X gypsum board serving as noncombustible protection for interior surfaces of wall and ceiling assemblies determined in accordance with Table 722.7.1(1) shall be installed in accordance with the following:

1. Each layer shall be attached with Type S drywall screws of sufficient length to penetrate the mass timber at least 1 inch when driven flush with the paper surface of the gypsum board.

Exception: The third layer, where determined necessary by Section 722.7, shall be permitted to be attached with 1 inch #6 Type S drywall screws to furring channels in accordance with ASTM C645.

2. Screws for attaching the base layer shall be 12 inches on center in both directions.
3. Screws for each layer after the base layer shall be 12 inches on center in both directions and offset from the screws of the previous layers by 4 inches in both directions.
4. All panel edges of any layer shall be offset 18 inches from those of the previous layer.
5. All panel edges shall be attached with screws sized and offset as in items 1 through 4 above and placed at least 1 inch but not more than 2 inches from the panel edge.
6. All panels installed at wall-to-ceiling intersections shall be installed such that ceiling panels are installed first and the wall panels are installed after the ceiling panel has been installed and is fitted tight to the ceiling panel. Where multiple layers are required, each layer shall repeat this process.
7. All panels installed at a wall-to-wall intersection shall be installed such that the panels covering an exterior wall or a wall with a greater fire resistance rating shall be installed first and the panels covering the other wall shall be fitted tight to the panel covering the first wall. Where multiple layers are required, each layer shall repeat this process.
8. Panel edges of the face layer shall be taped and finished with joint compound. Fastener heads shall be covered with joint compound.
9. Panel edges protecting mass timber elements adjacent to unprotected mass timber elements in accordance with Section 602.4.2.2 shall be covered with 1-1/4 inch metal corner bead and finished with joint compound.

722.7.2.2 Exterior surfaces. Layers of Type X gypsum board serving as noncombustible protection for the outside of the exterior heavy timber walls determined in accordance with Table 722.7.1(1) shall be fastened 12 inches on center each way and 6 inches on center at all joints or ends. All panel edges shall be attached with fasteners located at least 1 inch but not more than 2 inches from the panel edge. Fasteners shall comply with one of the following:

1. Galvanized nails of minimum 12 Gage with a 7/16 inch head of sufficient length to penetrate the mass timber a minimum of 1 inch.
2. Screws which comply with ASTM C1002 (Type S, Type W, or Type G) of sufficient length to penetrate the mass timber a minimum of 1 inch.

Reason:

The Ad Hoc Committee on Tall Wood Buildings (TWB) was created by the ICC Board to explore the science of tall wood buildings and take action on developing code changes for tall wood buildings. The TWB has created several code change proposals with respect to the concept of tall buildings of mass timber and the background information is at the end of this Statement. Within the statement are important links to information, including documents and videos, used in the deliberations which resulted in these proposals.

Typically, mass timber elements will be large due to structural requirements. In addition, CLT panels typically are utilized in odd number laminations. This typically results in excess capacity which means better fire endurance. Thus, mass timber elements are conservative in their fire resistance rating. Furthermore, the TWB decided to provide both a prescriptive path, as embodied in this proposal, and a performance path, embodied in another proposal.

This proposal outlines a method to calculate the fire resistance rating of a protected wood element by adding the fire resistance rating of the unprotected wood member together with the protection time provided by the noncombustible protection applied to the exposed wood.

This proposal should be considered as a companion proposal to the proposals creating new types of mass timber construction in Section 602.4 and the code proposal for Section 703.8 outlining a testing protocol to determine the contribution of noncombustible protection. This code proposal allows the user to select a prescriptive solution utilizing Type X gypsum wall board, which is deemed to comply with the basic requirements of this section and those of the proposed Section 602.4. Since this is a prescriptive solution, conditions of use such as attachment, finishing and edge treatment when bordering exposed mass timber areas, are also included in this section.

A proposal in Section 703.8 both forms the performance path for this determination and is the basis by which the contribution of the Noncombustible Protection to the fire resistance rating is determined. Testing of beams, columns, walls and ceiling panels has been used to establish the values found in table 722.7.1(b) for 1/2-inch Type X and 5/8-inch Type X gypsum board as well. Recent testing by AWC confirms the values derived from historic testing. A report is available at the following link: <http://bit.ly/WFC-firetestofGWBonCLT>. This link was confirmed active on 12/27/17.

Tests proposed in Section 703.8 may be used in the future to justify additional materials added to this table and should not be confused with “membrane protection” which is based on temperature rise on the unexposed side of a membrane attached to construction elements. Noncombustible construction is, instead, noncombustible material meeting the requirements of Section 703.5. Its contribution to the fire resistance rating of any building element is determined by this proposed new section. Simply put, it is determined by measuring the fire resistance time in minutes to the point of structural failure of a mass timber building element and then conducting a second test measuring the fire resistance time in minutes taken to the same point of structural failure. Each test is to be conducted with identical mass timber element with identical load, construction and condition, but with the proposed noncombustible protection applied to the second assembly. The difference in time between the two samples is the contribution, in minutes, of the noncombustible protection.

Background information: The ICC Board approved the establishment of an ad hoc committee for tall wood buildings in December of 2015. The purpose of the ad hoc committee is to explore the science of tall wood buildings and to investigate the feasibility and take action on developing code changes for tall wood buildings. The committee is comprised of a balance of stakeholders with additional opportunities for interested parties to participate in the four Work Groups established by the ad hoc committee, namely: Code; Fire; Standards/Definitions; and Structural. For more information, be sure to visit the ICC website <https://www.iccsafe.org/codes-tech-support/cs/icc-ad-hoc-committee-on-tall-wood-buildings/> (link active and up to date as of 12/27/17). As seen in the “Meeting Minutes and Documents” and “Resource Documents” sections of the committee web page, the ad hoc committee reviewed a substantial amount of information in order to provide technical justification for code proposals.

The ad hoc committee developed proposals for the followings code sections. The committee believes this package of code changes will result in regulations that adequately address the fire and life safety issues of tall mass timber buildings.

IBC Code Section	Description
403.3.2	Water supply requirements for fire pumps in high rise buildings of Type IVA and IVB construction.
504.3	Allowable building height (feet) for buildings of Type IVA, IVB and IVC construction. No changes to Type IV HT construction.
504.4	Allowable building height (stories) for buildings of Type IVA, IVB and IVC construction. No changes to Type IV HT.
506.2	Allowable building area for buildings of Type IVA, IVB and IVC construction. No changes to Type IV HT.
508.4.4.1 509.4.1.1 (new)	Requirements for mass timber building elements serving as fire barriers or horizontal assemblies in buildings of Type IVB or IVC construction.
602.4	Type of Construction requirements for new proposed types of construction: Types IVA, IVB and IVC. No changes to Type IV HT construction. Includes definitions for new terms: Mass timber and Noncombustible protection (mass timber). THIS IS THE KEY CODE CHANGE PROPOSAL WHICH OUTLINES THE CONSTRUCTION REQUIREMENTS FOR THE PROPOSED NEW TYPE OF MASS TIMBER BUILDINGS. THE PROPOSAL ALSO ADDRESSES CONCEALED SPACES, ADHESIVE PERFORMANCE AND EXTERIOR WALL PROTECTION.
703.8 (new)	The performance method to determine the increase to the fire resistance rating provided by noncombustible protection applied to the mass timber building element.
703.9 (new)	Requirements for sealants and adhesives to be placed at abutting edges and intersections of mass timber building elements. The reason statement references a Group B proposal to Chapter 17 for special inspection requirements of sealants and adhesives.
718.2.1	Requirements on the use of mass timber building elements used for Fireblocking.
722.7 (new)	Requirements for the fire resistance rating of mass timber elements, including minimum required protection and gypsum board attachment requirements.
3102	Requirements for membrane structures using Type IV HT construction.
3314.7 (new)	New special precautions during construction of buildings of Types IVA, IVB and IVC construction: Standpipes; Water supply for fire department connections; Noncombustible protection required for mass timber elements as construction height increases.
Appendix	Requirements for walls, floors and roofs of Type IV HT construction in buildings located in Fire Districts.
IFC Code Section	Description
701.6	Requirements which stipulate the owner's responsibility to maintain inventory of all required fire resistance rated construction in buildings of Types IVA and IVB construction. This includes an annual inspection and proper repair where necessary.
Proposed changes to be submitted in 2019 Group B	
IBC Chapter 17	Required special inspections of mass timber construction <ul style="list-style-type: none"> • Structural • Sealants and adhesives (see IBC 703.8)
IBC Chapter 23	An update to referenced standard APA PRG 320 Standard for Performance –rated Cross-laminated Timber which is currently undergoing revision to ensure the adequacy of the adhesives under fire conditions.

In addition, fire tests designed to simulate the three new construction types (Types IVA, IVB and IVC) in the ad hoc committee proposals were conducted at the Alcohol Tobacco and Firearms test lab facility. The TWB was involved in the design of the tests, and many members witnessed the test in person or online. The results of the series of 5 fire tests provide additional support for these proposals, and validate the fire performance for each of the types of construction proposed by the committee. The fire tests consisted of one-bedroom apartments on two levels, with both apartments having a corridor leading to a stair. The purpose of the tests was to address the contribution of mass timber to a fire, the performance of connections, the performance of through-penetration fire stops, and to evaluate conditions for responding fire personnel.

To review a summary of the fire tests, please visit:

<http://bit.ly/ATF-firetestreport>

To watch summary videos of the fire tests, which are accelerated to run in 3 ½ minutes, please visit:

<http://bit.ly/ATF-firetestvideos>

Both of these links were confirmed active on 12/27/17.

Cost Impact

The code change proposal will not increase or decrease the cost of construction .

This section provides information that was not previously set forth in the code, and does not change the requirements of current code, thus there is no cost impact when compared with present requirements.

Analysis: The referenced standards, ASTM C645 and ASTM C1002, are currently referenced in 2018 I-codes.

Internal ID: 945

FS82-18

IBC: 803.9, IFC 803.9

Proponent: Marcelo Hirschler, GBH International, representing GBH International (gbhint@aol.com)

2018 International Building Code

Revise as follows:

803.9 High-density polyethylene (HDPE) and polypropylene (PP)-Solid thermoplastics. Where solid thermoplastics that melt and drip when exposed to flame, including but not limited to, polypropylene (PP), high-density polyethylene or polypropylene is (HDPE), solid polycarbonate, solid polystyrene, and solid acrylic materials, are used as an interior finish, #they shall comply with Section 803.1.1.

2018 International Fire Code

Revise as follows:

[BF] 803.9 High-density polyethylene (HDPE) and polypropylene (PP)-Solid thermoplastics. Where solid thermoplastics that melt and drip when exposed to flame, including but not limited to, polypropylene (PP), high-density polyethylene or polypropylene is (HDPE), solid polycarbonate, solid polystyrene, and solid acrylic materials, are used as an interior finish, #they shall comply with Section 803.1.1.

Reason:

The same reason that HDPE and PP are not permitted to be used as interior finish simply based on testing to ASTM E84 also applies to some solid thermoplastics that melt and drip when exposed to flame. For proper fire safety they should be tested to NFPA 286.

Note that this applies purely to interior finish and that it does not cover foam plastics, which are already required to be tested to NFPA 286 if used as interior finish.

Cost Impact

The code change proposal will increase the cost of construction .

This will require more materials to be tested in accordance with a more rigorous (and more reliable) but more costly fire test.

Internal ID: 309

FS83-18

IBC: 803.9

Proponent: Julius Ballanco, JB Engineering and Code Consulting, P.C., representing Bradley Corporation (JBENGINEER@aol.com)

2018 International Building Code

Revise as follows:

803.9 High-density polyethylene (HDPE) and polypropylene (PP). Where high-density polyethylene or polypropylene is used as an *interior finish*, it shall comply with Section 803.1.1. Where high-density polyethylene toilet and urinal partitions are used, they shall comply with Section 1209 and the interior finish requirements of Section 803.1.1 or 803.1.2.

Reason:

This proposal adds a requirement indicating that toilet and urinal partitions made of HDPE or PP are not regulated by this section. The interior finish requirements for toilet and urinal partitions would still apply, however, the Class of material in Table 803.3 would be the applicable requirements.

The interior finish requirements are concerned with the fire aspects of a building component. However, there is no history of a fire concern with HDPE water closet and urinal. A study was completed by NFPA Research entitled, "Non-Residential Structure Fires That Originated in Lavatories, Locker Rooms or Coat Check Rooms," dated November 2017, authored by Marty Ahrens. The report shows no fire issue with water closet or urinal partitions. There are no fire deaths reported from fires originating in a commercial toilet room. The results are not surprising.

HDPE partition manufacturers have a framing system that protects the edges of the HDPE material. As a result, the HDPE partitions cannot readily ignite. The typical cause of a fire origin in a toilet room is the waste basket or electrical appliance. There is no fire ignition source in the vicinity of a water closet or urinal partition.

What must be understood is that while fire-retardant chemicals can be added to HDPE used for water closet and urinal partitions, however, the chemicals change the exterior surface requirements of the partitions. The fire-retardant chemicals make the surface more porous. It also makes the surface less scratch resistant. As a result, the partitions would no longer have the same cleanliness and sanitation aspect required for a water closet or urinal partition. This would in effect eliminate the acceptance of HDPE partitions.

The NFPA study clearly establishes that a fire hazard with HDPE water closet or urinal partitions does not exist. It is more important to emphasize the sanitary and health issues as identified in Section 1209.

Cost Impact

The code change proposal will decrease the cost of construction .

The change will remove an unnecessary requirement for water closet and urinal partitions.

Internal ID: 1502

FS84-18

IBC: 803.10

Proponent: Michael O'Brian, Chair, representing FCAC (fcac@iccsafe.org)

2018 International Building Code

Revise as follows:

803.10 Site-fabricated stretch systems. Where used as interior wall or interior ceiling finish materials, *site-fabricated stretch systems* containing all three components described in the definition in Chapter 2 shall be tested in the manner intended for use, and shall comply with the requirements of Section 803.1.1 ~~803.1.2~~ or with the requirements of Class A in accordance with Section 803.1.2. If the materials are tested in accordance with ASTM E84 or UL 723, specimen preparation and mounting shall be in accordance with ASTM E2573.

2018 International Fire Code

Revise as follows:

[BF] 803.10 Site-fabricated stretch systems. Where used as newly installed interior wall or interior ceiling finish materials, site-fabricated stretch systems containing all three components described in the definition in Chapter 2 shall be tested in the manner intended for use, and shall comply with the requirements of Section 803.1.1 or ~~803.1.2~~ with the requirements of Class A in accordance with Section 803.1.2. If the materials are tested in accordance with ASTM E84 or UL 723, specimen preparation and mounting shall be in accordance with ASTM E2573.

Reason:

This is clarification because interpretation is unclear but these systems were always intended to meet Class A in ASTM E84.

Cost Impact

The code change proposal will not increase or decrease the cost of construction .

Since this is meant at a clarification of intent the cost should not increase. However, due to the confusion on interpretation it is possible that different flame spread ratings have been required and this could have some effect on cost.

Internal ID: 291

FS85-18

IBC: TABLE 803.13

Proponent: Gregory Nicholls, representing The American Institute of Architects (gnicholls@preview-group.com)

2018 International Building Code

Revise as follows:

**TABLE 803.13
INTERIOR WALL AND CEILING FINISH REQUIREMENTS BY OCCUPANCYk**

GROUP	SPRINKLERED ¹			NONSPRINKLERED		
	Interior exit stairways and ramps and exit passageways ^{a,r}	<u>Enclosures for fire-resistive rated corridors, and enclosure for surfaces adjacent to exit access stairways and ramps, and unenclosed exit discharge elements</u> ^{a,n}	Rooms and enclosed spaces ^c	Interior exit stairways and ramps and exit passageways ^a	<u>Enclosures for fire-resistive rated corridors, and enclosure for surfaces adjacent to exit access stairways and ramps, and enclosed portions of exit discharge elements</u> ^{a,n}	Rooms and enclosed spaces ^c
A-1 & A-2	B	B	C	A	A ^d	B ^e
A-3 ^f , A-4, A-5	B	B	C	A	A ^d	C
B, E, M, R-1	B	C ^m	C	A	B	C
R-4	B	C	C	A	B	B
F	C	C	C	B	C	C
H	B	B	C ^g	A	A	B
I-1	B	C	C	A	B	B
I-2	B	B	B ^{h, i}	A	A	B
I-3	A	A ^j	C	A	A	B
I-4	B	B	B ^{h, i}	A	A	B
R-2	C	C	C	B	B	C
R-3	C	C	C	C	C	C
S	C	C	C	B	B	C
U	No restrictions			No restrictions		

For SI: 1 inch = 25.4 mm, 1 square foot = 0.0929 m².

a. Class C interior finish materials shall be permitted for wainscoting or paneling of not more than 1,000 square feet of applied surface area in the grade lobby where applied directly to a noncombustible base or over furring strips applied to a noncombustible base and fireblocked as required by Section 803.15.1.

- b. In other than Group I-3 occupancies in buildings less than three stories above grade plane, Class B interior finish for nonsprinklered buildings and Class C interior finish for sprinklered buildings shall be permitted in interior exit stairways and ramps.
- c. Requirements for rooms and enclosed spaces shall be based on spaces enclosed by partitions. Where a fire-resistance rating is required for structural elements, the enclosing partitions shall extend from the floor to the ceiling. Partitions that do not comply with this shall be considered to be enclosing spaces and the rooms or spaces on both sides shall be considered to be one room or space. In determining the applicable requirements for rooms and enclosed spaces, the specific occupancy thereof shall be the governing factor regardless of the group classification of the building or structure.
- d. Lobby areas in Group A-1, A-2 and A-3 occupancies shall be not less than Class B materials.
- e. Class C interior finish materials shall be permitted in places of assembly with an occupant load of 300 persons or less.
- f. For places of religious worship, wood used for ornamental purposes, trusses, paneling or chancel furnishing shall be permitted.
- g. Class B material is required where the building exceeds two stories.
- h. Class C interior finish materials shall be permitted in administrative spaces.
- i. Class C interior finish materials shall be permitted in rooms with a capacity of four persons or less.
- j. Class B materials shall be permitted as wainscoting extending not more than 48 inches above the finished floor in corridors and exit access stairways and ramps.
- k. Finish materials as provided for in other sections of this code.
- l. Applies when protected by an automatic sprinkler system installed in accordance with Section 903.3.1.1 or 903.3.1.2.
- m. Corridors in ambulatory care facilities shall be provided with Class A or B materials.
- n. Unenclosed exit discharge elements include those providing the fire-resistive rated floors below

Reason:

The current table does not clearly or adequately address what should be done with exit discharge elements allowed by Section 1028.1 exception 1. The reference to "lobbies" appears to be an antiquated reference to the older versions of the legacy codes that used that term in the exit discharge description. But the problem is that the intermediate space (such as a lobby or vestibule) allowed by the exception does not have to be enclosed when certain conditions are met, and is not an interior exit stairway, ramp or passageway.

This proposal seeks to revise the table to provide clear direction on where these exit discharge elements belong, and provide those spaces with requirements less restrictive than enclosed exit elements but more restrictive than typical spaces. Experience seeing numerous office and hotel lobbies used as an exit discharge element would lead us to believe that this table has not been applied to the finishes in exit discharge spaces, so this change also attempts to remain in focus to actual construction.

With these areas such as corridors, exit access elements and discharges which are often open to the rest of the floor, where does the authority of this table stop and start? For corridors that are not required to be rated, what difference is there between the spaces they can and often are open to and the corridor itself? So the proposal delineates fire-resistive corridors from others that can be treated as rooms and spaces. For the unenclosed exit access stairs and ramps and the unenclosed exit discharge elements, the new text provides some clarity that the limits of the finish ratings would only apply to the walls and ceilings by the ramps, stairs, vestibules and lobby/exit discharge path. The addition of footnote n provides for the rated floor below these elements required by the conditions in the exception to Section 1028.1.

Cost Impact

The code change proposal will not increase or decrease the cost of construction .

The current code is not clear on what is required for finishes in exit discharge elements, so there is no comparative cost.

FS86-18

IBC: [F] 806.9 (New)

Proponent: John Williams, Chair, representing Healthcare Committee (AHC@iccsafe.org); Michael O'Brian, Chair, representing FCAC (fcac@iccsafe.org)

2018 International Building Code

Add new text as follows:

[F] 806.9 Combustible lockers. Where lockers constructed of combustible materials are used, the lockers shall be considered to be interior finish and shall comply with Section 803.

Exception: Lockers constructed entirely of wood and noncombustible materials shall be permitted to be used wherever interior finish materials are required to meet a Class C classification in accordance with Section 803.1.2.

Reason:

The requirements in this section are contained in the IFC Section 808.4, but they should equally be contained in the IBC, because lockers are often included in building plans (such as in schools) and they should be checked at the time of issuing the certificate of occupancy instead of waiting until after the building is in use.

This proposal is submitted by the ICC Fire Code Action Committee (FCAC) and ICC Committee on Healthcare (CHC).

The FCAC was established by the ICC Board of Directors to pursue opportunities to improve and enhance assigned International Codes with regard to fire safety and hazardous materials in new and existing buildings and facilities and the protection of life and property in wildland urban interface areas. In 2017 the Fire-CAC has held 3 open meetings. In addition, there were numerous conference calls, Regional Work Group and Task Group meetings for the current code development cycle, which included members of the committees as well as any interested parties, to discuss and debate the proposed changes. Related documentation and reports are posted on the FCAC website at: <https://www.iccsafe.org/codes-tech-support/cs/fire-code-action-committee-fcac/>

The CHC was established by the ICC Board to evaluate and assess contemporary code issues relating to healthcare facilities. This is a joint effort between ICC and the American Society for Healthcare Engineering (ASHE), a subsidiary of the American Hospital Association, to eliminate duplication and conflicts in healthcare regulation. In 2017 the CHC held 2 open meetings and numerous conference calls, which included members of the committees as well as any interested parties, to discuss and debate the proposed changes. Information on the CHC, including: meeting agendas; minutes; reports; resource documents; presentations; and all other materials developed in conjunction with the CHC effort can be downloaded from the CHC website at: <https://www.iccsafe.org/codes-tech-support/cs/icc-committee-on-healthcare/>.

Cost Impact

The code change proposal will not increase or decrease the cost of construction .

This is already in the IFC, so there is no technical change

Internal ID: 600

FS87-18

IBC: 909.20.5.1 (New)

Proponent: Douglas Evans, DHE FPE LLC, representing DHE FPE LLC (dhefpe@gmail.com)

2018 International Building Code

Add new text as follows:

909.20.5.1 Stair pressurization relief damper. A controlled relief vent capable of discharging a minimum of 2,500 cfm (1180 L/s) of air at the design pressure difference shall be located in the upper portion of the pressurized stair enclosure.

Reason:

The requirement for a dampered relief opening capable of discharging at least 2500 cfm allows a safety factor for stair pressurization to compensate for doors opening and closing. The dampered opening relieves excessive pressure when doors are opened and closed and reduces the potential for over pressurization. Further, if smoke does infiltrate the stair, the dampered relief allows smoke to vent to atmosphere.

This is an overpressure feature that only opens when the pressure in the stair sufficiently exceeds the required 0.10 inches of water pressure. This design constraint helps compensate for pressure differences created by stack effect by requiring fans to provide a slightly higher flow and pressure than needed. Depending on the height of the stair and design of the pressurization system, this option may even allow omission of pressure sensors and variable speed fans designed to compensate for stack effect conditions that vary through the year.

Cost Impact

The code change proposal will decrease the cost of construction .

This additional requirement is actually expected to decrease construction costs as described in the preceding justification statement.

Internal ID: 1630

FS88-18

IBC: 909.20, 909.20.4, 909.20.5, , 909.20.5.1, 909.20.5.2, 909.20.5.3, 909.20.6

Proponent: Lee Kranz, representing Washington Association of Building Officials Technical Code Development Committee (lkranz@bellevuewa.gov)

2018 International Building Code

1023.11 Smokeproof enclosures. Where required by Section 403.5.4, 405.7.2 or 412.2.2.1, interior exit *stairways* and *ramps* shall be *smokeproof enclosures* in accordance with Section 909.20.

Revise as follows:

909.20 Smokeproof enclosures. Where required by Section 1023.11, a smokeproof enclosure shall be constructed in accordance with this section. A smokeproof enclosure shall consist of an *interior exit stairway* or *ramp* that is enclosed in accordance with the applicable provisions of Section 1023 and an open exterior balcony ~~or ventilated vestibule~~ meeting the requirements of this section. Where access to the roof is required by the International Fire Code, such access shall be from the smokeproof enclosure where a smokeproof enclosure is required.

Delete without substitution:

~~**909.20.4 Mechanical ventilation alternative.** The provisions of Sections 909.20.4.1 through 909.20.4.4 shall apply to ventilation of smokeproof enclosures by mechanical means.~~

~~**909.20.4.1 Vestibule doors.** The door assembly from the building into the vestibule shall be a *fire door assembly* complying with Section 716.2.2.1. The door assembly from the vestibule to the *stairway* or *ramp* shall not have less than a 20-minute *fire protection rating* and shall meet the requirements for a smoke door assembly in accordance with Section 716.2.2.1. The door shall be installed in accordance with NFPA 105.~~

~~**909.20.4.2 Vestibule ventilation.** The vestibule shall be supplied with not less than one air change per minute and the exhaust shall be not less than 150 percent of supply. Supply air shall enter and exhaust air shall discharge from the vestibule through separate, tightly constructed ducts used only for that purpose. Supply air shall enter the vestibule within 6 inches (152 mm) of the floor level. The top of the exhaust register shall be located at the top of the smoke trap but not more than 6 inches (152 mm) down from the top of the trap, and shall be entirely within the smoke trap area. Doors in the open position shall not obstruct duct openings. Duct openings with controlling *dampers* are permitted where necessary to meet the design requirements, but *dampers* are not otherwise required.~~

~~**909.20.4.2.1 Engineered ventilation system.** Where a specially engineered system is used, the system shall exhaust a quantity of air equal to not less than 90 air changes per hour from any vestibule in the emergency operation mode and shall be sized to handle three vestibules simultaneously. Smoke detectors shall be located at the floor side entrance to each vestibule and shall activate the system for the affected vestibule. Smoke detectors shall be installed in accordance with Section 907.3.~~

~~**909.20.4.3 Smoke trap.** The vestibule ceiling shall be not less than 20 inches (508 mm) higher than the door opening into the vestibule to serve as a smoke and heat trap and to provide an upward moving air column. The height shall not be decreased unless *approved* and justified by design and test.~~

~~**909.20.4.4 Stairway or ramp shaft air movement system.** The *stairway* or *ramp* shaft shall be provided with a dampered relief opening and supplied with sufficient air to maintain a minimum positive pressure of 0.10 inch of water (25 Pa) in the shaft relative to the vestibule with all doors closed.~~

Revise as follows:

909.20.5 Stairway and ramp pressurization alternative. Where the building is equipped throughout with an *automatic sprinkler system* in accordance with Section 903.3.1.1, the vestibule is not required, provided that each interior *exit stairway* or *ramp* is pressurized to not less than 0.10 inch of water (25 Pa) and not more than 0.35 inches of water (87 Pa) in the shaft relative to the building measured with all *interior exit stairway* and *ramp* doors closed under maximum anticipated conditions of stack effect and wind effect. The activation of ventilating equipment required by this section shall be by smoke detectors installed at each floor level at an *approved* location at the entrance to the smokeproof enclosure. Smoke detectors shall be installed in accordance with Section 907.3.

Delete without substitution:

~~**909.20.6 Ventilating equipment.** The activation of ventilating equipment required by the alternatives in Sections 909.20.4 and 909.20.5 shall be by smoke detectors installed at each floor level at an *approved* location at the entrance to the smokeproof enclosure. When the closing device for the *stairway* and *ramp* shaft and vestibule doors is activated by smoke detection or power failure, the mechanical equipment shall activate and operate at the required performance levels. Smoke detectors shall be installed in accordance with Section 907.3.~~

Revise as follows:

~~**909.20.6-1909.20.5.1 Ventilation systems.** Smokeproof enclosure ventilation systems shall be independent of other building ventilation systems. The equipment, control wiring, power wiring and ductwork shall comply with one of the following:~~

1. Equipment, control wiring, power wiring and ductwork shall be located exterior to the building and directly connected to the smokeproof enclosure or connected to the smokeproof enclosure by ductwork enclosed by not less than 2-hour *fire barriers* constructed in accordance with Section 707 or *horizontal assemblies* constructed in accordance with Section 711, or both.
2. Equipment, control wiring, power wiring and ductwork shall be located within the smokeproof enclosure with intake or exhaust directly from and to the outside or through ductwork enclosed by not less than 2-hour *fire barriers* constructed in accordance with Section 707 or *horizontal assemblies* constructed in accordance with Section 711, or both.
3. Equipment, control wiring, power wiring and ductwork shall be located within the building if separated from the remainder of the building, including other mechanical equipment, by not less than 2-hour *fire barriers* constructed in accordance with Section 707 or *horizontal assemblies* constructed in accordance with Section 711, or both.

Exceptions:

1. Control wiring and power wiring located outside of a 2-hour fire barrier construction shall be protected using any one of the following methods:
 - 1.1. Cables used for survivability of required critical circuits shall be listed in accordance with UL 2196 and shall have a fire-resistance rating of not less than 2 hours.
 - 1.2. Where encased with not less than 2 inches (51 mm) of concrete.
 - 1.3. Electrical circuit protective systems shall have a fire-resistance rating of not less than 2 hours. Electrical circuit protective systems shall be installed in accordance with their listing requirements.

~~**909.20.6-2909.20.5.2 Standby power.** Mechanical vestibule and *stairway* and *ramp* shaft ventilation systems and automatic fire detection systems shall be provided with standby power in accordance with Section ~~2702-2702.~~~~

~~**909.20.6-3909.20.5.3 Acceptance and testing.** Before the mechanical equipment is *approved*, the system shall be tested in the presence of the *building official* to confirm that the system is operating in compliance with these requirements.~~

Reason:

The mechanical ventilation alternative for interior exit stairways or ramps found in Section 909.20.4 is outdated. This option was a carry-over from the legacy codes and is rarely if ever used to reduce the risk of smoke contamination of a stair or ramp enclosure. When smokeproof enclosures are required by Section 1023.11 designers typically use pressurized stairways to prevent smoke from entering the stair or ramp enclosure thus vestibules are no longer required or used. It is unlikely that a smokeproof enclosure will be required in a nonsprinklered building, which is the only reason the mechanical ventilation alternative would ever be utilized. Also, with the current design requirements of 909.20.4, there is a potential risk associated with exhausting 150% of the makeup air from the vestibule thereby creating a negative pressure in the vestibule as it relates to adjacent spaces allowing smoke to enter the enclosure & the interior exit stairway or ramp.

This provision is rarely if ever used so why keep it in the code?

Cost Impact

The code change proposal will not increase or decrease the cost of construction.

The mechanical ventilation alternative is not typically used so removing it from the code should have no financial impacts pro or con.

FS89-18

IBC: 909.20, 909.20.4, 909.20.6

Proponent: Douglas Evans, representing DHE FPE LLC (dhefpe@gmail.com)

2018 International Building Code

Revise as follows:

909.20 Smokeproof enclosures. Where required by Section 1023.11, a smokeproof enclosure shall be constructed in accordance with this section. A smokeproof enclosure shall consist of an *interior exit stairway* or *ramp* that is enclosed in accordance with the applicable provisions of Section 1023 and an open exterior balcony ~~or ventilated vestibule~~ meeting the requirements of this section. Where access to the roof is required by the International Fire Code, such access shall be from the smokeproof enclosure where a smokeproof enclosure is required.

Delete without substitution:

~~**909.20.4 Mechanical ventilation alternative.** The provisions of Sections 909.20.4.1 through 909.20.4.4 shall apply to ventilation of smokeproof enclosures by mechanical means.~~

~~**909.20.4.1 Vestibule doors.** The door assembly from the building into the vestibule shall be a *fire door assembly* complying with Section 716.2.2.1. The door assembly from the vestibule to the *stairway* or *ramp* shall not have less than a 20-minute *fire protection rating* and shall meet the requirements for a smoke door assembly in accordance with Section 716.2.2.1. The door shall be installed in accordance with NFPA 105.~~

~~**909.20.4.2 Vestibule ventilation.** The vestibule shall be supplied with not less than one air change per minute and the exhaust shall be not less than 150 percent of supply. Supply air shall enter and exhaust air shall discharge from the vestibule through separate, tightly constructed ducts used only for that purpose. Supply air shall enter the vestibule within 6 inches (152 mm) of the floor level. The top of the exhaust register shall be located at the top of the smoke trap but not more than 6 inches (152 mm) down from the top of the trap, and shall be entirely within the smoke trap area. Doors in the open position shall not obstruct duct openings. Duct openings with controlling *dampers* are permitted where necessary to meet the design requirements, but *dampers* are not otherwise required.~~

~~**909.20.4.2.1 Engineered ventilation system.** Where a specially engineered system is used, the system shall exhaust a quantity of air equal to not less than 90 air changes per hour from any vestibule in the emergency operation mode and shall be sized to handle three vestibules simultaneously. Smoke detectors shall be located at the floor side entrance to each vestibule and shall activate the system for the affected vestibule. Smoke detectors shall be installed in accordance with Section 907.3.~~

~~**909.20.4.3 Smoke trap.** The vestibule ceiling shall be not less than 20 inches (508 mm) higher than the door opening into the vestibule to serve as a smoke and heat trap and to provide an upward moving air column. The height shall not be decreased unless *approved* and justified by design and test.~~

~~**909.20.4.4 Stairway or ramp shaft air movement system.** The *stairway* or *ramp* shaft shall be provided with a dampered relief opening and supplied with sufficient air to maintain a minimum positive pressure of 0.10 inch of water (25 Pa) in the shaft relative to the vestibule with all doors closed.~~

Revise as follows:

909.20.6 Ventilating equipment. The activation of ventilating equipment required by the ~~alternatives~~ alternative in Sections 909.20.4 and Section 909.20.5 shall be by smoke detectors installed at each floor level at an *approved* location at the entrance to the smokeproof enclosure. When the closing device for the *stairway* and *ramp* shaft and vestibule doors is activated by smoke detection or power failure, the mechanical equipment shall activate and operate at the required performance levels. Smoke detectors shall be installed in accordance with Section 907.3.

Reason:

This proposal eliminates the mechanical ventilation alternative. Although the mechanical ventilation alternative has been in the IBC since inception, it seems unlikely this option is used very often, if at all. This is due to the complexity of the design and the additional equipment necessary to achieve the specified results.

There are two primary approaches to meet the mechanical ventilation option. One approach requires large supply and exhaust fans, as well as the associated ducts to serve all vestibules simultaneously. A second approach requires not

only the supply and exhaust ducts, but also one supply and one exhaust damper in each vestibule. With this approach, each damper in every vestibule will have to properly configure for the system to function.

Section 909.20.4.3 requires a minimum ceiling height of 20 inches above the door. With a minimum door opening height of 80 inches as required by Section 1010.1.1, these constraints dictate a minimum of 8 feet 4 inches from the top of one slab to the bottom of the slab above. Adding another 6 inches for a reasonable slab thickness gives almost 9 foot slab-to-slab height. Although this may not be a hardship for most multi-story buildings, this will impact some designs.

Cost Impact

The code change proposal will decrease the cost of construction .

Due to the complexity of this option, it is more expensive to design, construct, commission and maintain than other recognized approaches for smokeproof enclosures.

Internal ID: 1634

FS90-18

IBC: 909.20, 909.20.6 (New), 909.20.6.1 (New), 909.20.6.2 (New), 909.20.6.3 (New), 909.20.7

Proponent: Douglas Evans, representing DHE FPE LLC (dhefpe@gmail.com)

2018 International Building Code

Revise as follows:

909.20 Smokeproof enclosures. Where required by Section 1023.11, a smokeproof enclosure shall be constructed in accordance with this section. A smokeproof enclosure shall consist of an *interior exit stairway* or *ramp* that is enclosed in accordance with the applicable provisions of Section 1023 and an open exterior balcony or ventilated vestibule or pressurized stair and pressurized entrance vestibule meeting the requirements of this section. Where access to the roof is required by the International Fire Code, such access shall be from the smokeproof enclosure where a smokeproof enclosure is required.

Add new text as follows:

909.20.6 Pressurized stair and vestibule alternative. The provisions of Sections 909.20.6.1 through 909.20.6.3 shall apply to smokeproof enclosures using a pressurized stair and pressurized entrance vestibule.

909.20.6.1 Vestibule doors. The door assembly from the building into the vestibule shall be a fire door assembly complying with Section 716.2.2.1. The door assembly from the vestibule to the stairway shall not have less than a 20-minute fire protection rating and meet the requirements for a smoke door assembly in accordance with Section 716.2.2.1. The door shall be installed in accordance with NFPA 105.

909.20.6.2 Pressure difference. The stair enclosure shall be pressurized to a minimum of 0.05 inch of water gage (12.44 Pa) positive pressure relative to the vestibule with all stairway doors closed under the maximum anticipated stack pressures. The vestibule, with doors closed, shall have a minimum of 0.05 inch of water gage (12.44 Pa) positive pressure relative to the fire floor. The pressure difference across doors shall not exceed 30 lbs (133-N) maximum force to begin opening the door.

909.20.6.3 Dampered relief opening. A controlled relief vent capable of discharging a minimum of 2,500 cfm (1180 L/s) of air at the design pressure difference shall be located in the upper portion of the pressurized exit enclosure.

Revise as follows:

909.20.6-909.20.7 Ventilating equipment. The activation of ventilating equipment required by the alternatives in Sections 909.20.4, 909.20.5 and ~~909.20.5-909.20.6~~ shall be by smoke detectors installed at each floor level at an *approved* location at the entrance to the smokeproof enclosure. When the closing device for the *stairway* and *ramp* shaft and vestibule doors is activated by smoke detection or power failure, the mechanical equipment shall activate and operate at the required performance levels. Smoke detectors shall be installed in accordance with Section 907.3.

Reason:

This amendment will allow the use of a pressurized stair along with a pressurized entrance vestibule as one of the options for smokeproof enclosures. The pressurized stair and vestibule option has been used in Southern Nevada for over 20 years and has a proven track record. This proposal allows the existing options to remain, but also allows a pressurized stair and vestibule as another option. This proposal has been shown to work well for high-rise buildings where outdoor air temperatures cause stack effect conditions. Due to potentially excessive stack effect pressures, the stair pressurization alternative outlined in Section 909.20.5 can be difficult to implement. This proposal provides an option for designers when dealing with tall buildings.

This option essentially creates an "air lock" between the pressurized stair and normally occupied portion(s) of the building, which makes it easier to achieve the 0.10 between the stair and building without over pressurizing the stair. Leakage under/around the door separating the stair from the vestibule has been found to be sufficient to pressurize vestibules without additional ducts or fans. At times, an adjustable door sweep is used to regulate leakage and meet the associated pressure requirements.

This option is less expensive to design, construct, commission and maintain than the ventilated vestibule option. It can be a viable option for tall stairs and reduces the impact of stack effect. The stair pressurization (w/o vestibule) option is difficult to implement in tall buildings due to pressure differences created by stack effect.

Cost Impact

The code change proposal will decrease the cost of construction .

This proposal allows an additional option for smokeproof enclosures and can reduce overall cost during design, construction, commissioning and continued building maintenance.

Internal ID: 1637

FS91-18

IBC: 1402.2

Proponent: Theresa Weston, representing Air Barrier Association (theresa.a.weston@dupont.com)

2018 International Building Code

Revise as follows:

1402.2 Weather protection. *Exterior walls* shall provide the building with a weather-resistant *exterior wall envelope*. The *exterior wall envelope* shall include flashing, as described in Section 1404.4. The *exterior wall envelope* shall be designed and constructed in such a manner as to prevent the accumulation of water within the wall assembly by providing a *water-resistive barrier* behind the exterior veneer, as described in Section 1403.2, and a means for draining water that enters the assembly to the exterior. Protection against condensation in the *exterior wall* assembly shall be provided in accordance with Section 1404.3 and Section C402.5 of the International Energy Conservation Code.

Exceptions:

1. A weather-resistant *exterior wall envelope* shall not be required over concrete or masonry walls designed in accordance with Chapters 19 and 21, respectively.
2. Compliance with the requirements for a means of drainage, and the requirements of Sections 1403.2 and 1404.4, shall not be required for an *exterior wall envelope* that has been demonstrated through testing to resist wind-driven rain, including joints, penetrations and intersections with dissimilar materials, in accordance with ASTM E331 under the following conditions:
 - 2.1. *Exterior wall envelope* test assemblies shall include not fewer than one opening, one control joint, one wall/eave interface and one wall sill. Tested openings and penetrations shall be representative of the intended end-use configuration.
 - 2.2. *Exterior wall envelope* test assemblies shall be not less than 4 feet by 8 feet (1219 mm by 2438 mm) in size.
 - 2.3. *Exterior wall envelope* assemblies shall be tested at a minimum differential pressure of 6.24 pounds per square foot (psf) (0.297 kN/m²).
 - 2.4. *Exterior wall envelope* assemblies shall be subjected to a minimum test exposure duration of 2 hours.The *exterior wall envelope* design shall be considered to resist wind-driven rain where the results of testing indicate that water did not penetrate control joints in the *exterior wall envelope*, joints at the perimeter of openings or intersections of terminations with dissimilar materials.
3. *Exterior insulation and finish systems* (EIFS) complying with Section 1407.4.1.

Reason:

Air leakage control is currently dealt with in the I-codes based on energy efficiency considerations, but it is also critical to protection against moisture condensation. Air leakage can move 100x more moisture than vapor diffusion, and vapor retarders will not work properly without air leakage control. As stated in the Whole Building Design Guide:

“Moisture contributed by air leakage is a significant source and should be a serious concern in the design of the wall system. In fact, the design of the building envelope for minimizing air leakage is more critical than the design of the vapor barrier.

To illustrate this point, consider that the amount of moisture contributed to a building by the air that flows through a crack 1/16th inch thick by 1 foot long is just over 5 pints per day in a light breeze. In contrast, the amount of moisture contributed by vapor diffusion through a 10 foot by 50-foot painted block wall over the same period equals just under 1/3 of a pint (about 5 ounces).”

It is important to include air leakage control in Section 1402.2 as it will highlight its importance to moisture management and facilitate the inclusion of air leakage control in water management details.

Cost Impact

The code change proposal will increase the cost of construction .

For jurisdictions that adopt both the IBC and IECC, there will be no cost impact as this proposed provision is already in existing code provisions. For jurisdictions that do not adopt the IECC, there will be increased cost of incorporating air barriers into the construction, but that cost will be offset by reducing air infiltration related condensation moisture

issues and associated liability.

Internal ID: 2144

FS92-18

IBC: 1402.2

Proponent: Benjamin Meyer, representing self (2ben.meyer@gmail.com)

2018 International Building Code

Revise as follows:

1402.2 Weather protection. *Exterior walls* shall provide the building with a weather-resistant *exterior wall envelope*. The *exterior wall envelope* shall include flashing, as described in Section 1404.4. The *exterior wall envelope* shall be designed and constructed in such a manner as to prevent the accumulation of water within the wall assembly by providing a *water-resistive barrier* behind the exterior veneer, as described in Section 1403.2, and a means for draining water that enters the assembly to the exterior. Protection against condensation in the *exterior wall* assembly shall be provided in accordance with Section 1404.3.

Exceptions:

1. ~~A weather resistant exterior wall envelope shall not be required over concrete or masonry walls designed in accordance with Chapters 19 and 21, respectively.~~
- 2.1. Compliance with the requirements for a means of drainage, and the requirements of Sections 1403.2 and 1404.4, shall not be required for an *exterior wall envelope* that has been demonstrated through testing to resist wind-driven rain, including joints, penetrations and intersections with dissimilar materials, in accordance with ASTM E331 under the following conditions:
 - 1.1. ~~2.1.~~ *Exterior wall envelope* test assemblies shall include not fewer than one opening, one control joint, one wall/eave interface and one wall sill. Tested openings and penetrations shall be representative of the intended end-use configuration.
 - 1.2. ~~2.2.~~ *Exterior wall envelope* test assemblies shall be not less than 4 feet by 8 feet (1219 mm by 2438 mm) in size.
 - 1.3. ~~2.3.~~ *Exterior wall envelope* assemblies shall be tested at a minimum differential pressure of 6.24 pounds per square foot (psf) (0.297 kN/m²).
 - 1.4. ~~2.4.~~ *Exterior wall envelope* assemblies shall be subjected to a minimum test exposure duration of 2 hours.

The *exterior wall envelope* design shall be considered to resist wind-driven rain where the results of testing indicate that water did not penetrate control joints in the *exterior wall envelope*, joints at the perimeter of openings or intersections of terminations with dissimilar materials.
2. ~~3.~~ *Exterior insulation and finish systems* (EIFS) complying with Section 1407.4.1.

Reason:

Conformance with the material and structural requirements described in chapters 19 and 21 do not directly correspond with the water management (WRB) performance specified in 1402.2.

For example Chapter 21 contains structural requirements for Dry-Stack Masonry (2114). Compliance with these requirements in no way ensures complies with 1402.2.

Cost Impact

The code change proposal will not increase or decrease the cost of construction .

proposal doesn't add requirements

Internal ID: 2388

FS93-18

IBC: 202 (New), 1402.2, 1404.5 (New), 1404.5.1 (New), 1404.5.2 (New), Chapter 35

Proponent: Jay Crandell, P.E., ARES Consulting, representing Foam Sheathing Committee of the American Chemistry Council (jcrandell@aresconsulting.biz)

2018 International Building Code

Add new definition as follows:

WIND-DRIVEN RAIN INDEX. A representation of the combined climate effects of wind and rain which affect the magnitude and frequency of rain deposition on building exterior surfaces.

Revise as follows:

1402.2 Weather protection. *Exterior walls* shall provide the building with a weather-resistant *exterior wall envelope*. The *exterior wall envelope* shall include flashing, as described in Section 1404.4. The *exterior wall envelope* shall be designed and constructed in such a manner as to prevent the accumulation of water within the wall assembly by providing a *water-resistive barrier* behind the exterior veneer, as described in Section 1403.2, and a means for draining water that enters the assembly to the exterior. Protection against condensation in the *exterior wall* assembly shall be provided in accordance with Section 1404.3. Where required by Section 1404.5, additional provisions for weather protection shall be provided.

Exceptions:

1. A weather-resistant *exterior wall envelope* shall not be required over concrete or masonry walls designed in accordance with Chapters 19 and 21, respectively.
2. Compliance with the requirements for a means of drainage, and the requirements of Sections 1403.2 and 1404.4, shall not be required for an *exterior wall envelope* that has been demonstrated through testing to resist wind-driven rain, including joints, penetrations and intersections with dissimilar materials, in accordance with ASTM E331 under the following conditions:
 - 2.1. *Exterior wall envelope* test assemblies shall include not fewer than one opening, one control joint, one wall/eave interface and one wall sill. Tested openings and penetrations shall be representative of the intended end-use configuration.
 - 2.2. *Exterior wall envelope* test assemblies shall be not less than 4 feet by 8 feet (1219 mm by 2438 mm) in size.
 - 2.3. *Exterior wall envelope* assemblies shall be tested at a minimum differential pressure of 6.24 pounds per square foot (psf) (0.297 kN/m²).
 - 2.4. *Exterior wall envelope* assemblies shall be subjected to a minimum test exposure duration of 2 hours.

The *exterior wall envelope* design shall be considered to resist wind-driven rain where the results of testing indicate that water did not penetrate control joints in the *exterior wall envelope*, joints at the perimeter of openings or intersections of terminations with dissimilar materials.

3. *Exterior insulation and finish systems* (EIFS) complying with Section 1407.4.1.

Add new text as follows:

1404.5 Additional provisions for weather protection. The provisions of Section 1404.5.1 and 1404.5.2 shall apply in the required wind-driven rain index and climate zones and, where not required, shall be permitted.

1404.5.1 Enhanced drainage. Where the wind-driven rain index of Figure 1404.5.1 is 4 or greater, the means of drainage required by Section 1402.2 shall be satisfied by one of the following:

1. A drained air space not less than nominal 3/16-inch deep behind the cladding.
2. An open drainage material, not less than nominal 1/4-inch thick and with a cross-section area that is not less than 80 percent open, installed between the cladding and backing,
3. Hollow-backed metal or vinyl siding installed in accordance with the manufacturer's instructions, or
4. An approved drainage design with drainage performance at least equivalent to Items 1, 2, or 3, or

not less than 90 percent drainage efficiency as measured in accordance with ASTM E 2273 or Annex A2 of ASTM E 2925.



Reprinted, with permission, from ASTM STP778 Masonry: Materials, Properties, and Performance, copyright ASTM International, 100 Barr Harbor Drive, West Conshohocken, PA 19428.

1404.5.1
WIND-DRIVEN RAIN INDEX

1404.5.2 Protection against inward vapor drive. Where claddings addressed in Sections 1404.10 and 1404.15 are used in Climate Zones 1A, 2A, or 3A in accordance with Chapter 3 of the International Energy Conservation Code and installed over wood-based or gypsum-based sheathing, a ventilated air space shall be provided in accordance with Exception 2 in Section 2510.6 and drainage shall be provided in accordance with Items 1, 2, or 4 of Section 1404.5.1.

Exceptions:

1. An approved drainage and ventilation design, including vent inlets and outlets, with ventilation performance at least equivalent to Items 1 or 2 of Section 1404.5.1 as measured in accordance with Annex A1 of ASTM E 2925.
2. An air space for ventilation shall not be required where foam plastic insulating sheathing complying with ASTM C 578 or ASTM C 1289 is located between the cladding and the wood-based or gypsum-based sheathing.

Add new standard(s) follows:

CHAPTER 35 REFERENCED STANDARDS

ASTM

ASTM International
100 Barr Harbor Drive, P.O. Box
C700
West Conshohocken PA 19428-
2959

E2925-17:

Standard Specification for Manufactured Polymeric Drainage and Ventilation Materials Used to Provide a Rainscreen Function

Reason:

Proposed new Section 1404.5 is needed to provide adequate moisture performance for exterior wall coverings and vulnerable wall materials in hazardous climate conditions that are prone to cause moisture problems. In these cases, the generic minimum weather protection practices in the code are unreliable and increase the risk of moisture durability problems including material degradation, rot, and mold. This proposal will serve to address this problem and provide risk-consistent solutions in coordination with climate hazards (e.g., wind-driven rain) as they vary across the U.S. In regions of low-to-moderate hazard, this proposal requires no change in practice but permits the enhanced provisions to be used.

First, the existing exceptions in Section 1402.2 are unchanged. Therefore, where these existing exceptions apply, the enhanced requirements of proposed Section 1404.5 would not apply because the charging language for use of Section 1404.5 is located in Section 1402.2.

Second, the provisions of proposed Section 1404.5 are required only in the more extreme climates of the U.S. with regard to moisture effects on exterior walls of buildings. However, the practices employed are beneficial in all climates; therefore, they are permitted to be used in other climate conditions.

Within Section 1404.5, proposed Section 1404.5.1 addresses drainage for exterior wall coverings in climates with significant wind-driven rain hazard. In these climates, the need for enhanced drainage is well understood from experience and research. For example, these provisions are modeled very closely after provisions found in the National Building Code of Canada (Section 9.27) as applied to climates with significant wind-driven rain. The NBC provisions were necessitated by wide-spread water intrusion problems and are based on research, field studies, and expert judgment. In the U.S. similar problems are occurring, particularly with conventional stucco installations on wood frame construction. These provisions will also help mitigate risk of water intrusion damage related to normal imperfections in exterior wall covering installation.

Also within Section 1404.5, proposed Section 1404.5.2 addresses inward vapor drives which present a well-known cause of moisture problems for walls clad with "reservoir claddings" such as adhered veneer (1404.10) and stucco (1404.15). These cladding types absorb water rainwater and then while drying (particularly with impinging energy from the sun) create significant inward vapor drives, forcing water vapor through underlying layer(s), such as the water resistive barrier, and into moisture sensitive materials within the wall assembly (such as wood-based and gypsum-based sheathings). Moisture sensitive materials such as wood-based and gypsum-based sheathings backing stucco and adhered veneers are particularly vulnerable if not adequately protected. Other reservoir claddings, like anchored masonry veneer (i.e., not adhered), already comply with Section 1404.5.2 due to the presence of a nominal 1-inch or greater vented air space behind the veneer.

The proposed provisions of Section 1404.5.2 coordinate with changes made last code cycle for Section 2510.6, exception 2. However, these requirements are broadly applicable and, thus, are best located in Chapter 14 and not hidden in an incomplete exception statement back in Chapter 25. More importantly, Section 1404.5.2 ensures the ventilated air space required in Exception 2 of Section 2510.6 also complies with the drainage requirements of Section 1404.5.1 and this serves to define a minimum size or effectiveness of the ventilated air space. Additionally, the charging language for Section 1404.5 permits these enhanced practices or options to be used in any climate zone, not just those limited conditions addressed in Exception 2 of Section 2510.6.

The exceptions in Section 1404.5.2 provide useful alternative means of addressing inward vapor drives from reservoir claddings. The first exception provides a means to justify use of alternative drainage and ventilation designs. The second exception provides a means to avoid use of a ventilated air space. It works by way of blocking the inward movement of water vapor from the reservoir cladding by use of lower permeance foam plastic insulating sheathing behind the cladding. This practice has been used successfully to prevent inward vapor drives from reservoir claddings and protect underlying moisture sensitive wall materials. It is also commonly used with 1-coat stucco systems. The drainage requirements of Section 1404.5.1 would still apply where applicable.

The provisions of Section 1404.5 are supported by various sources as documented in the research report ("Moisture Control Guide") referenced in the bibliography. The wind-driven rain map provided as new Figure 1404.5.1 is based on an ASTM paper as noted as the source for the figure. It is also very consistent with a more recent wind-driven rain climatology study by the University of Georgia.

From a resiliency perspective, it is no less appropriate to consider actions to address variation of building durability climate hazards across the U.S. as it is to consider variation in structural hazards such as wind, snow, and earthquake loads as they also vary across the U.S. In fact, durability problems related to climate-driven moisture effects and associated vulnerabilities of construction materials and methods often contribute to damages from structural hazards. Thus, this proposal will help ensure intended structural performance for the service life of a building.

Bibliography:

Model Moisture Control Guidelines for Light-Frame Walls: A Building Code Supplement for Builders, Designers, and Code Officials, ABTG Research Report No. 1701-01, 2017, Applied Building Technology Group LLC, <https://www.appliedbuildingtech.com/rr/1701-01>

Cost Impact

The code change proposal will increase the cost of construction .

cdpACCESS does not provide a option to declare "The code change proposal will increase and decrease cost of construction" (which is perhaps a more appropriate description of the cost impact of this proposal for reasons that follow).

For most of the U.S. these provisions do not apply and there is no cost impact. However, proposed Section 1404.5.1 will increase costs for cladding installation on some types of construction in the more hazardous wind-driven rain climates by requiring provision of adequate drainage behind claddings. However, there is no change or cost impact for claddings that already meet the requirements (e.g., anchored brick veneer) or which are already inherently drained (e.g., vinyl siding). There also is no change or cost impact for walls of concrete or masonry construction per Section 1402.2, Exception 1, or for claddings meeting the existing performance requirement of Section 1402.2, Exception 2 (e.g., barrier EIFS).

Proposed Section 1404.5.2 would appear to increase cost for stucco and adhered veneer installations that are in hot-humid climates and which do not already address inward driven moisture, but the drainage and ventilation requirements are already vaguely required (complete in concept but not in detail) in Exception 2 of Section 2510.6 of the code. Also, Exception 1 of Section 1402.2 prevents any cost impact to installations on concrete or masonry construction. Finally, proposed Section 1404.5.2 includes additional options for compliance (e.g., exceptions) that may actually reduce cost of compliance for some stucco and adhered veneer installations.

Without robust data on the variation in construction types and cladding types by regional climate conditions, it is difficult to determine the magnitude of cost impact and whether or not it is a net increase or decrease in cost for a population of buildings representative of those built using the IBC. But, it is clear in some specific cases there could be a cost increase. In these specific cases, one conventional solution that would satisfy both Sections 1404.5.1 and 1404.5.2 would be to provide furring behind the cladding (and this is not necessarily the low-cost solution). The total cost of furring including overhead and profit per the 2017 RS Means Open Shop Building Construction Costs manual ranges from about \$0.60/SF (\$1.17/LF 1x3 wood furring pneumatically nailed to wood framing at 24"oc) to \$2.22/SF (metal furring at 16"oc). Considering the many cases where there is no cost impact, this proposal will range in cost impact of \$0/SF to as much as \$2.22/SF depending on a number of factors. It is likely that the net impact is closer to \$0/SF than \$2.22/SF.

Internal ID: 1017

FS94-18

IBC: 1402.3 (New)

Proponent: David Collins, The American Institute of Architects, representing The American Institute of Architects (dcollins@preview-group.com)

2018 International Building Code

Add new text as follows:

1402.3 Fenestration. Vertical fenestration and skylights, including windows and doors, shall comply with the International Energy Conservation Code, as applicable.

Reason:

The IECC contains detailed requirements regarding doors, windows and skylights which apply to all buildings. Primarily fenestration is located in the exterior walls of the building. Obviously skylights are located in the roof. The IBC already addresses the quantity and fire resistance of openings in Chapter 7. Chapter 14 addresses the overall integrity of exterior walls. Providing energy efficient fenestration is part of the design consideration of exterior walls. The fenestration requirements are somewhat complex and should remain in the IECC, but the existence of the IECC provisions need to be referenced in the IBC to reduce the possibility of them being overlooked.

This proposal is submitted by the ICC Fire Code Action Committee (FCAC). The FCAC was established by the ICC Board of Directors to pursue opportunities to improve and enhance assigned International Codes with regard to fire safety and hazardous materials in new and existing buildings and facilities and the protection of life and property in wildland urban interface areas. In 2017 the Fire-CAC has held 3 open meetings. In addition, there were numerous conference calls, Regional Work Group and Task Group meetings for the current code development cycle, which included members of the committees as well as any interested parties, to discuss and debate the proposed changes. Related documentation and reports are posted on the FCAC website at: <https://www.iccsafe.org/codes-tech-support/cs/fire-code-action-committee-fcac/>

Cost Impact

The code change proposal will not increase or decrease the cost of construction .

This requirement already exists in the IECC. Inclusions in the IBC doesn't result in any construction not already anticipated.

Internal ID: 1168

FS95-18

IBC: 1402.5 (New)

Proponent: Tim Earl, GBH International, representing self (tearl@gbhinternational.com)

2018 International Building Code

Add new text as follows:

1402.5 Exterior wall envelope. Exterior walls on buildings of Type I, II, III, or IV construction that are greater than 40 feet (12,192 mm) in height above grade plane where the exterior wall envelope contains a combustible material, the complete exterior wall envelope shall be tested as a system in accordance with and comply with the acceptance criteria of NFPA 285 unless compliance with NFPA 285 is specifically exempted elsewhere in this Chapter.

Exception: An exterior wall envelope where the only combustible component is a water-resistive barrier in compliance with section 1402.6.

Reason:

This code change proposal is a generic requirement that ensures that all exterior wall envelope systems containing combustible materials must be tested to NFPA 285 as a complete system (if they exceed 40 ft. in height) unless otherwise exempted by other provisions of Chapter 14.

This proposal is followed by a series of proposals addressing various issues associated with combustible materials in exterior walls. The intent of these proposals is to provide a reasonable set of code requirements to ensure fire safety and weather protection for buildings that utilize combustible materials and/or assemblies for the building exterior wall envelope. Just as at present, no testing of completely non-combustible exterior walls would be required.

An alternate proposal addresses added requirements in the case of the presence of projections or interior corners.

The issue of wind effects has been raised but no standard test (or standardized variations of a standard test) exists that can address that.

The definition of “exterior wall envelope” in the IBC makes it clear that it is the “product” that needs to be tested because the fire performance of any system is affected by the fire performance of all its components. Therefore, if each component is fire tested individually and they all meet the requirements, there is no assurance that the entire system (meaning the exterior wall envelope) will perform adequately and meet the requirements.

This was always the intent for fire performance testing and minimum fire safety requirements of the chapter, but the section as currently written is not as clear as it should be. This is intended to address concerns with current language and requirements that could ultimately lead to tragic fires like the one in Grenfell Tower(London, England).

Note: The current definition for EXTERIOR WALL ENVELOPE in the IBC follows:

A system or assembly of exterior wall components, including exterior wall finish materials, that provides protection of the building structural members, including framing and sheathing materials, and conditioned interior space, from the detrimental effects of the exterior environment.

Cost Impact

The code change proposal will increase the cost of construction .

While it was always the intent that systems be tested, if users were not testing the entire exterior wall system, they will now be required to do so.

Internal ID: 1047

FS96-18

IBC: 1402.6 (New), 1402.6.1 (New), 1402.6.2 (New), 1402.6.3 (New), 1402.6.4 (New), 1402.6.5 (New), 1402.6.6 (New), 1402.6.7 (New), 1402.6.8 (New), 1402.6.9 (New), 1402.6.10 (New), 1402.6.11 (New), 1402.6.12 (New), 1402.6.13 (New), 1402.6.14 (New), 1402.6.15 (New), 1402.6.16 (New), 1402.6.17 (New), 1402.6.18 (New), 1402.6.19 (New), 1402.6.20 (New), 1402.6.21 (New), 1402.6.22 (New), 1402.6.23 (New), Chapter 35

Proponent: Ronald Nickson, Nickson Code Consulting, representing Rockwool (nicksoncodeconsulting@gmail.com)

2018 International Building Code

Add new text as follows:

1402.6 Flame spread of wall and attic protection. Where a building is not required to comply with NFPA 285, the exterior walls, or combination of exterior walls and eaves shall comply with Section 1402.6.20 when subject to fire testing in accordance with Sections 1402.6.2 through 1402.6.23.

Exceptions:

1. When there is or no observed flame spread above the lower 8 feet of the 16-foot test assembly, the wall assembly being tested is considered to have passed the test and is acceptable for use on the exterior of buildings.
2. Where eaves are located at a height greater than 8 feet above grade, the wall includes a gable vent or the building is designed with a parapet and low sloped roof, the exterior wall system above 8 feet from grade can be constructed using any alternative approved materials, provided the assembly of the lower 8 feet above grade of the wall assembly is permitted in accordance to Exception 1 to Section 1402.6.

1402.6.1 Wall sections deemed to comply. Wall assemblies listed below are deemed to comply with Section 1402.6 when the water-resistant barrier is the only combustible component and the water-resistive barrier has a peak heat release rate of less than 150 kW/m², a total peak heat release of less than 20 MJ/m² and an effective heat of combustion of less than 18 MJ/kg as determined in accordance with ASTM E1354 and has a flame spread index of 25 or less and a smoke-developed index of 450 or less as determined in accordance with ASTM E84 or UL 723. The ASTM E1354 test shall be conducted on specimens at the thickness intended for use, in the horizontal orientation and at an incident radiant heat flux of 50 kW/m².

1. The following wall assemble is deemed to comply with Section 1402.6 and is acceptable for use on the exterior wall of buildings when the attic space, exterior wall with gable vents, or parapet with low sloped roofs are more than 16 feet above grade plane. The wall assembly is required on the lower portion of the wall to a height of 16-feet above grade plane.
 - 1.1. Vinyl siding over water-resistant barrier and 1/2 inch plywood.
2. The following wall assemblies are deemed to comply with the Exception to Section 1402.6 and are acceptable for use on all exterior walls. The wall assembly is required on the lower portion of the wall to a height of 8-feet above grade plane.
 - 2.1. Fiber cement siding over water-resistant barrier and 1-inch R-5 EPS.
 - 2.2. 3/8-inch base coat stucco over water-resistant barrier and 1/2-inch plywood.
 - 2.3. 3/8-inch base coat stucco over water-resistant barrier, 1-inch R-5 EPS and 1/2-inch plywood.
 - 2.4. EIFS with 3/16-inch base coat of fiberglass mesh w/acrylic finish over water-resistant barrier and 1/2-inch plywood.
 - 2.5. EIFS with 3/16-inch base coat of fiberglass mesh w/acrylic finish over water-resistant barrier 1.5-inches EPS and 1/2-inch plywood.
 - 2.6. Vinyl siding over water-resistant barrier, mineral wool boards and 1/2-inch OSB.

1402.6.2 Fire test. This fire-test-response procedure prescribes a method to assess the fire performance of a vertically oriented specimen, eave projection and roof that encloses an attic space, exposed to direct flame impingement in a simulated external fire. When tested in accordance with 1402.6, when present, the eave construction shall be uniform and continuous around the perimeter of the test specimen.

1402.6.3 Test assembly. The test assembly wall dimensions shall be 16 feet wide and 16 feet high and have a

supporting wall on each end that extends back 8 feet at a 90-degree angle to the 16-foot wall. The eave shall be constructed as an 18-inch projection, extending horizontally from the top of the 16-foot wall section. The roof and attic spaces shall be constructed such that the roof extends from the projection's fascia at an angle of 6:12. The roof shall be covered with 5/8-inch OSB roof sheathing and roofing materials. The roof members shall have an intermediate supporting vertical member extending from the top of the 16-foot wall as well as at the ends of the 8 foot walls.

1402.6.4 Joint detail. The test assembly shall incorporate joint detail(s) representative of actual installation.

1402.6.5 Wall detail. The wall assembly used as the test specimen shall include sheathing, weather barrier and cladding attached to the exterior surface of the structural support elements.

1402.6.6 Wall material. For wall assemblies composed of layered materials, such as sheathing, water-resistive barrier, continuous exterior insulation and siding (cladding), the installation of such layered materials shall be in accordance with the manufacturer's instructions, or in the absence of such instructions, applicable building code requirements. In the absence of manufacturer's specifications, the wall assembly shall include the following minimum components: nominal 2x4 studs spaced 16 in (410 mm) on center, and the desired exterior siding material. If sheathing is used, tests shall be run on typical 7/16 in. oriented strand board (OSB) of Exposure 1 rating. Where specified by the manufacturer, sheathing materials and installation shall be in accordance with the manufacturer's instructions. The type, thickness, and installation method of any sheathing method of any sheathing shall be included in the report.

1402.6.7 Accelerated aging/weathering and pre-test conditions of test material. When required by a regulatory or other agency a pre-test accelerated aging/weathering of the samples shall be completed. The manufacturer shall have the option to conduct such weathering. Weathering shall be conducted as specified by the regulatory agency or applicable methods as specified for the product. Details of the weathering method used, or reference to a standard test method, shall be included in the report.

1402.6.8 Test samples. Two hygroscopic samples of each materials from the same stock from which the test assembly was constructed shall be tacked to the test assembly during construction in such a manner that they are easily removed. These pieces shall be conditioned with the completed test specimen.

1402.6.9 Storage. The completed test assemblies and samples shall be stored indoors at temperatures not lower than 60°F (16°C) nor higher than 90°F (32°C) for the period of time necessary to cure the assembly components. Test assemblies are to be stored so that each will be surrounded by freely circulating air.

1402.6.10 Sample testing. Just prior to the assembly testing, the pieces of hygroscopic materials prepared in 705.2.5.2.1 shall be tested for moisture content.

1402.6.11 Moisture determination. Samples of like materials shall be reported as the average. For lumber and other wood-based materials, use Test Method ASTM D4442. Alternatively, the moisture content for lumber and other wood-based materials is permitted to be measured using a moisture meter. For other hygroscopic materials, use test methods appropriate for those materials.

1402.6.12 Lumber used in the construction of the supporting wall structure. The moisture content shall not be more than 12 percent. For wood sheathing, the moisture content shall not exceed 8%. For other hygroscopic materials, the moisture shall be within ranges specified by the manufacturer before the assembly is constructed. These specified ranges shall be typical for exposure.

1402.6.13 Burner details. The ignition source for the test shall be gas diffusion burner with a nominal 4 in. wide by 39 in. (100 mm wide by 1000 mm) long porous top surface of a refractory material. With the exception of top surface dimensions, the essential configuration of the burner is comparable to the burner design describe in Test Method E2257.

1402.6.14 Burner enclosure. The burner enclosure shall be positioned so that it is centered relative to the width of the 16-foot test wall. The distance from the bottom of the test assembly to the top surface of the burner shall be 12 plus or minus 2 inches. (300 plus or minus 50 mm). The bottom of the test assembly shall be protected from burner fire exposure by the placement of a 4 foot (1220 mm) wide thermal barrier.

1402.6.15 Procedure. The ambient temperature in the test room shall be above 60°F (15°C) and the relative humidity shall be less than 75 percent. The test room shall be draft-protected and equipped with an exhaust hood system for removal of products of combustion during the test.

1402.6.16 Horizontal air flow. The horizontal air flow, measured at a horizontal distance of 20 inches. (0.5m) from

the edge of the wall assembly, shall not exceed 1.64 feet per second (0.5 m/s).

1402.6.17 Test assembly position. Prior to testing position the test assembly under the exhaust hood and set the gas burner for the prescribed level of output.

1402.6.18 Burner output. Once the burner output is verified, position the specimen holder assembly at the desired test location under the collection hood.

1402.6.19 Burner ignition. Simultaneously ignite the gas burner and start the timer marking the beginning of the test. Control the burner to a constant 100 kw output. Control the hood duct flow to collect all products of combustion.

1402.6.20 Flame exposure. Continue the flame exposure for a period of 20 minutes, or until such time that observations of flames in the attic space have been made. The specimen will have passed the test if no flame intrusion was observed into the attic space.

1402.6.21 Documentation. Perform photographic or video documentation, or both, before, during and after each test.

1402.6.22 Report. The report shall include the following:

1. Name and address of the testing laboratory.
2. Name and address of test sponsor.
3. Description of the test assembly including construction details of the wall system, details of individual components and the manufacturer's installation details and limitations as applicable.
4. Number of specimens tested.
5. Conditioning of test assemblies.
6. Pre-test accelerated aging/weathering exposure, as applicable.
7. Moisture content of hygroscopic elements of the wall system construction at the time of testing.
8. Details of the calibration including heat supply rate.
9. Date of test, identification number and date of report.

1402.6.23 Test Results. The test results shall include:

1. A notation of the time and location of the breach of the flame into the attic space.
2. A determination of the presence of glow on the unexposed side of the assembly at the end of the 60-minute observation period.
3. Observations of the burning characteristics of the exposed surface of the test during and after the test exposure.

Add new standard(s) follows:

ASTM

ASTM International
100 Barr Harbor Drive, P.O. Box
C700
West Conshohocken PA 19428-
2959
US

D4442-16:

Standard Test method for Heat and Visible Smoke Release Rates for Materials and Products Using an Oxygen Consumption Calorimeter

E2257-17:

Standard Test Method for Room Fire Test of Wall and Ceiling Materials and Assemblies

Reason:

The proposed change establishes a material-neutral, engineering solution, that allows for a wide range of options and design solutions to address the issue of fire spreading across the exterior wall and breaching the attic space, from

fires that originate on the exterior of a building. The risks associated to exterior fires of this type have been rising dramatically due to changes in the energy code that require more wall insulation. The increased insulation can be accommodated by increasing the wall thickness and installing more insulation in the wall cavity or by adding continuous insulation to the exterior of the more typical 2x4 or 2x6 wall. The exterior insulation does not present a fire hazard if it is non-combustible or protected in a way to prevent the insulation from being involved in a fire originating near the exterior wall from fires in nearby buildings, landscaping and in some cases radiative heat from the windows of a nearby building. This code proposal incorporated into the IBC is a means to evaluate the spread of fire on the exterior of buildings that also includes testing to determine if the fire spreads into the attic. The provisions in the proposal are based on fire testing research performed at UL, Fire Service Summary Report: Study of Residential Attic Fire Mitigation Tactics and Exterior Fire Spread Hazards on Firefighter Safety, funded by the Department of Homeland Security, and UL fire test, Verification Services Project for Exterior Wall Mock-up Fire Demonstration with Comfortboard 80 Insulation Products. Work is now underway with UL/ANSI to develop a standard that can be referenced in future editions of the ICC Codes.

Section 1402.6.1 adding the list of wall configurations deemed to comply includes wall assemblies that were tested in the above referenced test by UL. Based on that testing the listed wall assemblies would comply with the test procedure proposed by this code change. The section is based on provisions in the IECC that lists materials and assemblies that are deemed to comply with the IECC requirements for air leakage.

A report from NFPA Research entitled, Residential Structure Fires Originating On Outer Walls, Spreading On Exterior Walls Or Trim, and Beginning On An Outer Wall with Plastic, January 2018, identifies the problem that now exists because of the increased use of unprotected combustible products used to meet the current energy code requirements. The report documents the number of residential fires where the item contributing most flame spread was exterior sidewall covering and surface finish. From 2005 to 2015, this type of fire occurs on average 7663 times per year, causing an annual average of 50 casualties, 345 injuries and \$539 million in property loss.

UL fire test, Verification Services Project for Exterior Wall Mock-up Fire Demonstrations with Comfortboard 80 Insulation Products has shown that a fire can reach the attic in a building through the soffit in 2-3 minutes in buildings with unprotected combustible products in the exterior wall. In buildings with light siding and non-combustible insulation, tested using the same procedure, the exterior of the building does not catch on fire and thus the issue of the fire getting into the attic never happens.

The methodology proposed for fire testing in this proposal, assess the flame spread of the exterior wall and the time it takes for a fire to breach the attic space. To have a complete solution to the spread of fire into the attic it is imperative that the exterior wall meet the criteria in Section 1405.1 concerning Combustible Materials on the Exterior Side of Exterior Walls. A companion change has been submitted to add Type V construction to the section.

Cost Impact

The code change proposal will not increase or decrease the cost of construction .

The cost impact if any is minor. Some cost will be incurred by material manufacturers to determine compliance with the required test procedure. Material and installation cost are basically natural.

Analysis: A review of the standard proposed for inclusion in the code, ASTM E2257-17 and ASTM D4442-16, with regard to the ICC criteria for referenced standards (Section 3.6 of CP#28) will be posted on the ICC website on or before April 2, 2018.

Internal ID: 1827

FS97-18

IBC: 1402.5 (New), 1402.5.1 (New)

Proponent: Marcelo Hirschler, GBH International, representing GBH International (gbhint@aol.com)

2018 International Building Code

Add new text as follows:

1402.5 Exterior wall envelope. Exterior walls on buildings of Type I, II, III or IV construction that are greater than 40 feet (12 192 mm) in height above grade plane where the exterior wall envelope contains a combustible material, the complete exterior wall envelope shall be tested as a system in accordance with and comply with the acceptance criteria of NFPA 285 unless compliance with NFPA 285 is specifically exempted elsewhere in this Chapter.

Exception:An exterior wall envelope where the only combustible component is a water-resistive barrier in compliance with Section 1402.6

1402.5.1 Projections or inside corners. Where the exterior wall contains projections or inside corners, fire testing shall be conducted to demonstrate that the projections or inside corners will not negatively affect the fire safety of the exterior wall envelope. Such testing shall be related to the actual end-use configuration and be performed on the finished manufactured assembly in the maximum thickness intended for use. Assemblies tested shall include seams, joints and other typical details used in the installation of the assembly and shall be tested in the manner intended for use.

Reason:

This code change proposal is a generic requirement that ensures that all exterior wall envelope systems containing combustible materials must be tested to NFPA 285 as a complete system (if they exceed 40 ft. in height) unless otherwise exempted by other provisions of Chapter 14.

The reason fire testing of exterior wall envelopes is needed is because they can cause high fire losses (especially in terms of victims) and some examples are shown in the bibliography.

This proposal is followed by a series of proposals addressing various issues associated with combustible materials in exterior walls. The intent of these proposals is to provide a reasonable set of code requirements to ensure fire safety and weather protection for buildings that utilize combustible materials and/or assemblies for the building exterior wall envelope. Just as at present, no testing of completely non-combustible exterior walls would be required.

An alternate proposal does not address any added requirements in the case of the presence of projections or interior corners. That provides a simpler approach, particularly in view of the fact that it is difficult to define exactly what level of projections or corners would trigger the requirement.

The issue of wind effects has been raised but no standard test (or standardized variations of a standard test) exists that can address that.

The definition of "exterior wall envelope" in the IBC makes it clear that it is the "product" that needs to be tested because the fire performance of any system is affected by the fire performance of all its components. Therefore, if each component is fire tested individually and they all meet the requirements, there is no assurance that the entire system (meaning the exterior wall envelope) will perform adequately and meet the requirements.

This was always the intent for fire performance testing and minimum fire safety requirements of the chapter, but the section as currently written is not as clear as it should be. This is intended to address concerns with current language and requirements that could ultimately lead to tragic fires like the one in Grenfell Tower (London, England) in 2017.

Note: The current definition for EXTERIOR WALL ENVELOPE in the IBC follows:

A system or assembly of exterior wall components, including exterior wall finish materials, that provides protection of the building structural members, including framing and sheathing materials, and conditioned interior space, from the detrimental effects of the exterior environment.

Evidence exists that fires in exterior wall envelopes containing projections or inside corners may present additional fire hazard and, for that reason, a section requiring specialized testing is being proposed to be added. Standard tests can be modified or specific tests can be used to investigate the effects of such constructions on fire safety.

Bibliography:

Some links to the Grenfell tower fire in 2017 (with at least 71 fire fatalities) follow:

<http://www.bbc.com/news/uk-40301289> - accessed January 10 2018

<http://www.bbc.com/news/uk-england-london-40272168> - accessed January 10, 2018

https://en.wikipedia.org/wiki/Grenfell_Tower_fire - accessed January 10, 2018

Some links to other fires in very tall buildings throughout the world follow:

<http://www.telegraph.co.uk/news/worldnews/middleeast/dubai/12076792/Dubai-skyscraper-fire-new-years-eve-2015-live.html> - accessed January 10, 2018

<http://www.bbc.com/news/world-middle-east-31562099> - accessed January 10, 2018

<https://www.nytimes.com/2017/08/03/world/middleeast/torch-tower-dubai-fire.html> - accessed January 10, 2018

<http://www.nytimes.com/2009/02/10/world/asia/10beijing.html> - accessed January 10, 2018

<https://www.thebeijinger.com/blog/2014/02/09/five-years-ago-today-cctv-hotel-tower-burns> - accessed January 10, 2018

Other high rise fires:

Mermoz Tower, Roubaix, France May 2012. (2013): "l'incendie tour mermoz pompiers de Roubaix" [Movie]. YouTube; 2013 [cited 2013 19 July 2013]. Footage of Mermoz Tower Fire, Roubaix, France]. Available from: <http://www.youtube.com/watch?v=j4mIBQnUafQ.47>. (2012) - "Spectacular High-Rise Fire in France" 2012 [cited 2013 19 July 2013]. Blog report on Mermoz Tower fire, Roubaix, France]. Available from: <http://firegeezzer.com/2012/05/15/spectacular-high-rise-fire-in-france/.48>. (2012) - "High-rise blaze in 18-storey block in Roubaix, France " 2012 [cited 2013 19 July 2013]. Blog report on Mermoz Tower fire, Roubaix]. Available from: <http://www.blog.plumis.co.uk/2012/05/high-rise-blaze-in-18-storey-block-in.html>.

web-sites accessed January 10, 2018

A fire occurred in a 7 storey apartment building in Berlin Germany on 21 April 2005 (Broemme, A. (2005) "Berlin: Verheerender Fassadenbrand". Deutsche Feuerwehr-Zeitung Brandschutz. 2005 August, 2005.;number 6.) - website accessed January 10, 2018

Cost Impact

The code change proposal will increase the cost of construction .

It is possible that some exterior wall envelopes are not being tested at present. In that case, the cost of construction would be increased.

Internal ID: 791

FS98-18

IBC: 1402.5 (New),

Proponent: Michael O'Brian, Chair, representing FCAC (FCAC@iccsafe.org)

2018 International Building Code

Add new text as follows:

1402.5 Water-resistive barriers. Exterior walls on buildings of Type I, II, III or IV construction that are greater than 40 feet (12 192 mm) in height above grade plane and contain a combustible water-resistive barrier shall be tested in accordance with and comply with the acceptance criteria of NFPA 285. For the purposes of this section, fenestration products, flashing of fenestration products and water resistive barrier flashing and accessories at other locations, including through wall flashings, shall not be considered part of the water-resistive barrier.

Exceptions:

1. Walls in which the water-resistive barrier is the only combustible component and the exterior wall has a wall covering of brick, concrete, stone, terra cotta, stucco or steel with minimum thicknesses in accordance with Table 1404.2.
2. Walls in which the water-resistive barrier is the only combustible component and the water-resistive barrier complies with the following:
 - 2.1. A peak heat release rate of less than 150 kW/m², a total heat release of less than 20 MJ/m² and an effective heat of combustion of less than 18 MJ/kg when tested, on specimens at the thickness intended for use, in accordance with ASTM E 1354, in the horizontal orientation and at an incident radiant heat flux of 50 kW/m².
 - 2.2. A flame spread index of 25 or less and a smoke-developed index of 450 or less as determined in accordance with ASTM E 84 or UL 723, with test specimen preparation and mounting in accordance with ASTM E 2404.

Delete without substitution:

~~**1402.5 Vertical and lateral flame propagation.** Exterior walls on buildings of Type I, II, III or IV construction that are greater than 40 feet (12 192 mm) in height above grade plane and contain a combustible water resistive barrier shall be tested in accordance with and comply with the acceptance criteria of NFPA 285. For the purposes of this section, fenestration products, flashing of fenestration products and water resistive barrier flashing and accessories at other locations, including through wall flashings, shall not be considered part of the water resistive barrier.~~

~~Exceptions:~~

- ~~1. Walls in which the water resistive barrier is the only combustible component and the exterior wall has a wall covering of brick, concrete, stone, terra cotta, stucco or steel with minimum thicknesses in accordance with Table 1404.2.~~
- ~~2. Walls in which the water resistive barrier is the only combustible component and the water resistive barrier has a peak heat release rate of less than 150 kW/m², a total heat release of less than 20 MJ/m² and an effective heat of combustion of less than 18 MJ/kg as determined in accordance with ASTM E1354 and has a flame spread index of 25 or less and a smoke developed index of 450 or less as determined in accordance with ASTM E84 or UL 723. The ASTM E1354 test shall be conducted on specimens at the thickness intended for use, in the horizontal orientation and at an incident radiant heat flux of 50 kW/m².~~

Reason:

The water resistive barrier needs to meet two fire tests and they are somewhat garbled in this section and the proposed wording separates them out, placing the test to ASTM E1354 first and the test to ASTM E84 separately second. Also, when testing water resistive barriers in accordance with ASTM E84 the standard practice ASTM E2404 needs to be used, as made clear in the test method with the revisions developed by ASTM for ASTM E2404. This is consistent with the way that many other uses of ASTM E84 are indicated in chapter 8, for example.

This proposal is clarification of the language in the code because the scope of ASTM E2404 was expanded since the approval of the language in the 2018 code.

This proposal is submitted by the ICC Fire Code Action Committee (FCAC). The FCAC was established by the ICC Board of Directors to pursue opportunities to improve and enhance assigned International Codes with regard to fire safety

and hazardous materials in new and existing buildings and facilities and the protection of life and property in wildland urban interface areas. In 2017 the Fire-CAC has held 3 open meetings. In addition, there were numerous conference calls, Regional Work Group and Task Group meetings for the current code development cycle, which included members of the committees as well as any interested parties, to discuss and debate the proposed changes. Related documentation and reports are posted on the FCAC website at: <https://www.iccsafe.org/codes-tech-support/cs/fire-code-action-committee-fcac/>

This proposal is one in a series of related proposals intended to address different technical changes to Chapter 14. While the Fire Code Committee will consider each proposal independently, the intent is for approval of all proposals in this package which have been submitted as a correlated set of companion code change proposals.

The FCAC analyzed several fatal fires related to exterior façade/curtain wall fires in the development of these new code requirements. The intent of these proposals is to provide a reasonable set of code requirements to ensure fire safety and weather protection for buildings that utilize combustible materials and/or assemblies for the building exterior wall envelope.

1. Grenfell fire, London England:

Buildings Across U.S. Are Wrapped in Same Panels That Fueled Deadly London Fire: <https://www.wsj.com/articles/built-to-burn-thousands-of-buildings-world-wide-are-wrapped-in-combustible-panels-1508858048>

Why Grenfell Tower Burned: Regulators Put Cost Before Safety
<https://www.nytimes.com/2017/06/24/world/europe/grenfell-tower-london-fire.html>

2. Torch Tower Fire, Dubai

https://en.wikipedia.org/wiki/The_Marina_Torch January 8th, 2018

3. Address Hotel Fire, Dubai https://en.wikipedia.org/wiki/The_Address_Downtown_Dubai January 8th, 2018

Cost Impact

The code change proposal will not increase or decrease the cost of construction .

This proposal is simply a clarification of the required testing procedures.

Internal ID: 387

FS99-18

IBC: 1402.5, 1402.5.1 (New), Table 1402.5 (New)

Proponent: Jeffrey Shapiro, Lake Travis Fire Rescue, representing Lake Travis Fire Rescue (jshapiro@ltfr.org)

2018 International Building Code

Revise as follows:

1402.5 Vertical and lateral fire testing of exterior walls for flame propagation. *Exterior walls* on buildings of Type I, II, III or IV construction that are greater than 40 feet (12 192 mm) in height above grade plane ~~and contain a combustible water-resistive barrier shall be tested~~ that include combustible components shall be tested for flame propagation in accordance with and comply with the acceptance criteria of ~~NFPA 285, the test methods in Table 1402.5.~~ The complete exterior wall envelope shall be tested. For the purposes of this section, fenestration products, flashing of fenestration products and water-resistive-barrier flashing and accessories at other locations, including through wall flashings, shall not be considered part of the water-resistive ~~barrier.~~ barrier.

Exceptions:

1. Walls in which the *water-resistive barrier* is the only combustible component and the *exterior wall* has a wall covering of brick, concrete, stone, terra cotta, stucco or steel with minimum thicknesses in accordance with Table 1404.2.
2. Walls in which the *water-resistive barrier* is the only combustible component and the *water-resistive barrier* has a peak heat release rate of less than 150 kW/m², a total heat release of less than 20 MJ/m² and an effective heat of combustion of less than 18 MJ/kg as determined in accordance with ASTM E1354 and has a flame spread index of 25 or less and a smoke-developed index of 450 or less as determined in accordance with ASTM E84 or UL 723. The ASTM E1354 test shall be conducted on specimens at the thickness intended for use, in the horizontal orientation and at an incident radiant heat flux of 50 kW/m².

Add new text as follows:

1402.5.1 Supplemental requirements for test method. Where compliance with this section is required by Table 1402.5, the following shall apply:

1. Where an exterior wall will include one or more horizontal projections, the wall assembly shall be tested in accordance with NFPA 285 using a test sample that incorporates a horizontal projection that extends 5 feet from the exterior wall surface and is located 36 inches above the window opening. The tested assembly shall be required to comply with the acceptance criteria of NFPA 285.
2. Where an exterior wall will include one or more interior corners, the wall assembly shall be tested in accordance with one of the following options:
 - 2.1 NFPA 285 using a test sample that incorporates a corner that is located at the left or right edge of the window opening and extends an exterior wall surface at a right angle to the plane of the window that creates a 5 foot deep interior corner. The tested assembly shall be required to comply with the acceptance criteria of NFPA 285.
 - 2.2 NFPA 285 using the standard wall assembly and an additional test using the 16 foot parallel panel test specified in FM 4880. The tested assembly shall be required to comply with the acceptance criteria of both NFPA 285 and FM 4880.
3. Where an exterior wall will include both horizontal projections and interior corners, the wall shall be tested in accordance with both Item 1 and Item 2.
4. Tests in Item 1 and Item 2.1 shall be conducted with wind applied at 60 second intervals, accomplished by cycling the fan or fans on and off for the duration of the test. Fans shall apply a uniformly distributed wind speed of 30 feet per second to the face of the test assembly when running at full speed.

Table 1402.5
REQUIRED EXTERIOR WALL FIRE TEST METHOD

Exterior Wall Construction ^a	Required Test Method
Flat wall surface	ASTM E119
Exterior finish or coating	See Section 1402.5.1

a. Where no projections or interior corners exceed 12 inches, measured perpendicular to the wall surface, the wall is considered to be a flat wall surface

Reason:

For the past year, I have been attempting to get the NFPA 285 committee to consider adjustments to the NFPA 285 test procedure to address the issues of building geometry and wind. My approach has been to fight attempts to expand the use of NFPA 285 to include any wall assembly until changes are made to the standard to address these concerns. The development process for NFPA 285 has been very contentious on this issue, with the committee completely reversing course from one meeting to the next, and ultimately, the NFPA Standards Council refused to issue the latest update and returned the entire document to the technical committee.

The fire service has very little voice in the NFPA 285 process compared to industry interests, and it has been very difficult to get the committee to give these concerns due consideration, and on this issue, I am representing the perspective of the fire service and a code official. Lacking the ability to get appropriate consideration from the NFPA 285 technical committee, I am seeking to get the IBC to establish parameters for exterior wall tests that would be dictated to anyone writing test protocols for IBC buildings with walls regulated by this section.

The fire service is well aware of the effects of wind driven fires and of building geometry when it comes to fire behavior, and we can ill afford the risk of catastrophic high-rise fires involving exterior walls. While it has been claimed that there have been no such documented losses involving NFPA 285 compliant panels on buildings, the lack of a bad fire does not equate to a conclusion that everything is fine. Instead, numerous catastrophic exterior fires that have occurred just happened to occur on buildings with non-compliant walls assemblies. What would have happened if NFPA 285 compliant panels were used? Nobody can say for certain.

The current NFPA 285 test method is scoped to ONLY include non-bearing geometrically flat curtain walls attached to buildings, and I have no issue with the current test method continuing for this application. However, the effectiveness of this test method for assemblies with overhangs and inside corners that can intensify the fire exposure needs to be known before these untested geometric variations should be permitted by NFPA 285 or the IBC. UL's mantra is "know by test." We haven't tested, therefore, we don't know.

The addition of a wind application to the proposed samples with overhangs and/or corners recognizes that wind turbulence is likely to further increase fire intensity. Inside corners will form a flame vortex, and overhangs are expected to concentrate heat beneath the overhang. Either could cause an assembly that might pass the basic NFPA 285 test to fail.

The suggested parameters for the depth of extensions and wind speed (which approximately equates to 20 mph) are my best estimate, as a fire protection engineer and former firefighter, at a reasonable test. I have asked a variety of individuals involved in this issue to offer suggestions or run sample tests and got nowhere.

The fire service would be unwise to accept the risk of catastrophic high-rise fires by knowingly standing by while the NFPA 285 test method is exploited. Without knowing the fire performance consequences of stretching the test method to allow assemblies that are not well represented in the test, we cannot reasonably assure public safety or firefighter safety. We must do a better job of making sure we get this issue right because Grenfell Tower was a wake up call with respect to the consequences of inadequate testing. Do we really want to allow buildings to be built with untested wall configurations only to later learn that we screwed up and created a large pool of dangerous existing buildings? The time to address these concerns is now, before NFPA 285 loses its current scoping constraints and before tall wood buildings gain access to a test method that wasn't designed for that application.

Cost Impact

The code change proposal will not increase or decrease the cost of construction .

Currently, NFPA 285's scope is limited to not include all types of wall assemblies that are being addressed by this proposal. Compliance with additional tests being proposed may or may not have an impact on the cost of construction, depending on whether existing assemblies and materials are able to pass the proposed test protocols.

Internal ID: 2346

FS100-18

IBC: 1402.5

Proponent: William Hall, Portland Cement Association, representing Alliance For Concrete Codes and Standards (jhall@cement.org); Jason Thompson, representing Masonry Alliance for Codes and Standards (jthompson@ncma.org)

2018 International Building Code

Revise as follows:

1402.5 Vertical and lateral flame propagation. *Exterior walls* on buildings of Type I, II, III or IV construction that are greater than 40 feet (12 192 mm) in height above grade plane and contain a combustible *water-resistive barrier* shall be tested in accordance with and comply with the acceptance criteria of NFPA 285. The NFPA 285 test shall be conducted with an airflow velocity of 4.5 m/s (10 mph) applied perpendicular to the exterior face of the test specimen. The airflow velocity shall be measured at the exterior surface of the test specimen and one foot above the top of the test specimen window opening. For the purposes of this section, *fenestrationfenestrationwater-resistive-barrier* of the *water-resistive barrier*.

Exceptions:

1. Walls in which the *water-resistive barrier* is the only combustible component and the *exterior wall* has a wall covering of brick, concrete, stone, terra cotta, stucco or steel with minimum thicknesses in accordance with Table 1404.2.
2. Walls in which the *water-resistive barrier* is the only combustible component and the *water-resistive barrier* has a peak heat release rate of less than 150 kW/m², a total heat release of less than 20 MJ/m² and an effective heat of combustion of less than 18 MJ/kg as determined in accordance with ASTM E1354 and has a flame spread index of 25 or less and a smoke-developed index of 450 or less as determined in accordance with ASTM E84 or UL 723. The ASTM E1354 test shall be conducted on specimens at the thickness intended for use, in the horizontal orientation and at an incident radiant heat flux of 50 kW/m².

Reason:

It is common knowledge that air movement can intensify fire effects and spread fire. Ask any Boy Scout how they help the fire grow when using a campground fire pit for cooking. Or watch the news regarding the spread of wildfires through communities. Airflow does accelerate fire. But the question is by how much? That question remains unanswered even though we rely on exterior fire testing to assure there is not fire spread up the side of the building possibly resulting in a conflagration. The requirement for NFPA 285 testing in the IBC currently begins at 40 ft. of building height. The test is performed by placing a burner inside the test apparatus compartment and another burner at a window opening in the test specimen to simulate a room fire. The combination of the burners helps form a fire plume beginning at the top of window opening. Distance of fire spread as well rate of fire spread up the exterior wall is recorded and determined whether it meets the pass-fail criteria. This proposal would require that the test also include an air velocity of 4.5 m/s (10 mph) measured on the exterior wall test specimen surface at one foot above the opening and perpendicular to the wall. This would enable the proponents of products used in exterior wall assemblies to determine if their product is negatively impacted from a wind perspective during the test.. If the assembly fails further development of the assembly would be required.

A prevailing wind at a height of 40 ft. is common in any area of the country and provides reasoning that these assemblies should be tested in an environment that more closely resembles the intended application. Until, and unless standard development organizations incorporate provisions such as this into editions of standards, providing a wind component in the building code assures proper consideration of wind effects to fire spread on exterior walls assemblies required to be tested to NFPA 285

Cost Impact

The code change proposal will increase the cost of construction .

To pin point the increased cost of construction this proposal is difficult due to the costs being very dependant on the material the user intends to use. Air velocity will not affect many materials but will affect some.

Internal ID: 1546

FS101-18

IBC: 1402.5

Proponent: Andy Williams, Metal Construction Association, representing Metal Construction Association (afwilliams@Connect2amc.com)

2018 International Building Code

Revise as follows:

1402.5 Vertical and lateral flame propagation. *Exterior walls* on buildings of Type I, II, III or IV construction that are greater than 40 feet (12 192 mm) in height above grade plane and contain a combustible *water-resistive barrier* shall be tested in accordance with and comply with the acceptance criteria of NFPA 285. For the purposes of this section, ~~fenestration:~~

1. Laminate and composite panels that are manufactured using a combustible adhesive shall be considered as a combustible exterior wall element.
2. Fenestration products, flashing of *fenestration* products and *water-resistive-barrier* flashing and accessories at other locations, including through wall flashings, shall not be considered part of the *water-resistive barrier*.

Exceptions:

1. Walls in which the *water-resistive barrier* is the only combustible component and the *exterior wall* has a wall covering of brick, concrete, stone, terra cotta, stucco or steel with minimum thicknesses in accordance with Table 1404.2.
2. Walls in which the *water-resistive barrier* is the only combustible component and the *water-resistive barrier* has a peak heat release rate of less than 150 kW/m², a total heat release of less than 20 MJ/m² and an effective heat of combustion of less than 18 MJ/kg as determined in accordance with ASTM E1354 and has a flame spread index of 25 or less and a smoke-developed index of 450 or less as determined in accordance with ASTM E84 or UL 723. The ASTM E1354 test shall be conducted on specimens at the thickness intended for use, in the horizontal orientation and at an incident radiant heat flux of 50 kW/m².

Reason:

This text is being proposed to recognize that laminate or composite panels utilizing a combustible adhesive are adding combustibles to the exterior wall cladding and should be regulated in accordance with NFPA 285 Standard Fire Test Method for Evaluation of **Fire Propagation** Characteristics of Exterior Non-Load-Bearing Wall Assemblies Containing **Combustible Components**. While not high in volume, the only material separating these combustible adhesives from a fire is the exterior metal skin which is often only a thin layer of aluminum. Once the metal skin is penetrated by fire, the concern is that flames will spread rapidly through this untested material. There is no test criteria for the flame spread performance of the combustible adhesive in 703.5.2.

This change is proposed for Chapter 14 because this is an issue specific to Exterior Walls. There is no intent to address composite and laminate materials used for other applications that are not typically limited based on performance in NFPA 285.

The motivation for this proposal is to eliminate the potential for additional high rise cladding fires for panel systems that have not been tested to NFPA 285.

The current code makes an exception for the combustibles contained in the WRB (1402.5 Exception 1 and Exception 2). This panel type adds to the level of combustibles in the wall assembly and should be tested to show that there is no additional hazard for flame spread through the exterior wall assembly.

Typical panels have a noncombustible core with a layer of metal held on by a combustible adhesive. Two examples are shown below.



Corrugated Core (End View)



Upper Section - Cut away view of honeycomb core, combustible adhesive, with exterior aluminum skin

Lower Section - Same panel with exterior aluminum skin removed.

While there are other types of panels with alternate noncombustible cores and attached facers, the performance question is regarding the ability of the combustible adhesive to spread flame in a fire situation. This can only be done through recognized testing - in this case NFPA 285.

Cost Impact

The code change proposal will not increase or decrease the cost of construction .

Cost of NFPA 285 testing would be added to the overall cost of this product. Similar cost addition as other combustible wall assemblies.

Internal ID: 1378

FS102-18

IBC: 1402.5

Proponent: Bob Zabcik, representing Metal Construction Association (bobz@ncilp.com)

2018 International Building Code

Revise as follows:

1402.5 Vertical and lateral flame propagation. *Exterior walls* on buildings of Type I, II, III or IV construction that are greater than 40 feet (12 192 mm) in height above grade plane and contain a either a combustible water-resistive barrier or a combustible adhesive shall be tested in accordance with and comply with the acceptance criteria of NFPA 285. For the purposes of this section, *fenestration* products, flashing of *fenestration* products and *water-resistive-barrier* flashing and accessories at other locations, including through wall flashings, shall not be considered part of the *water-resistive barrier*.

Exceptions:

1. Walls in which the *water-resistive barrier* is the only combustible component and the *exterior wall* has a wall covering of brick, concrete, stone, terra cotta, stucco or steel with minimum thicknesses in accordance with Table 1404.2.
2. Walls in which the *water-resistive barrier* is the only combustible component and the *water-resistive barrier* has a peak heat release rate of less than 150 kW/m², a total heat release of less than 20 MJ/m² and an effective heat of combustion of less than 18 MJ/kg as determined in accordance with ASTM E1354 and has a flame spread index of 25 or less and a smoke-developed index of 450 or less as determined in accordance with ASTM E84 or UL 723. The ASTM E1354 test shall be conducted on specimens at the thickness intended for use, in the horizontal orientation and at an incident radiant heat flux of 50 kW/m².

Reason:

Composite or laminate panels, whether assembled in the field or factory, are often made out of primary materials which are considered to be non-combustible. However, when these materials are assembled with adhesives that may contribute to the flame spread and potential heat of the wall assembly, then testing such as NFPA 285 should be required. That is exactly the purpose of this passage in the context of Weather Resistive Barriers.

Cost Impact

The code change proposal will not increase or decrease the cost of construction .

The certification and testing costs of the subject products may increase.

Internal ID: 1914

FS103-18

IBC: 1402.5

Proponent: Thomas Meyers, Building Intuition, LLC, representing Self (codeconsultant@gmail.com)

2018 International Building Code

Revise as follows:

1402.5 Vertical and lateral flame propagation. *Exterior walls* on buildings of Type I, II, III or IV construction that are greater than 40 feet (12 192 mm) in height above grade plane and contain a combustible *water-resistive barrier* shall be tested in accordance with and comply with the acceptance criteria of NFPA 285. For the purposes of this section, *fenestration* products, flashing of *fenestration* products and *water-resistive-barrier* flashing and accessories at other locations, including through wall flashings, shall not be considered part of the *water-resistive barrier*.

Exceptions:

1. Walls in which the *water-resistive barrier* is the only combustible component and the *exterior wall* has a wall covering of brick, concrete, stone, terra cotta, stucco or steel with minimum thicknesses in accordance with Table 1404.2.
2. Walls in which the *water-resistive barrier* is the only combustible component and the *water-resistive barrier* has a peak heat release rate of less than 150 kW/m², a total heat release of less than 20 MJ/m² and an effective heat of combustion of less than 18 MJ/kg as determined in accordance with ASTM E1354 and has a flame spread index of 25 or less and a smoke-developed index of 450 or less as determined in accordance with ASTM E84 or UL 723. The ASTM E1354 test shall be conducted on specimens at the thickness intended for use, in the horizontal orientation and at an incident radiant heat flux of 50 kW/m².
3. Walls in which the water-resistive barrier is applied over pressure-impregnated, fire-retardant-treated-wood complying with Section 2303.2 and the water-resistive barrier complies with Exception 1 or Exception 2.

Reason:

Recent building cladding fires, such as the Grenfell Tower fire in London, have prompted review of the application of the NFPA 285 test standard to identify potential existing conflicts and areas of needed improvement or clarification.

Section 1402.5 appears to create a conflict resulting in significant industry confusion regarding the use of fire-retardant-treated wood (FRTW) in Types I, II, III, & IV construction as allowed by Section 602 and 603. This section suggests that FRTW cannot be used with a NFPA 285 compliant water-resistive barrier beyond 40 feet in height. The code currently allows FRTW used in Type III construction to extend to 85 feet in height. As FRTW does not meet the definition of “noncombustible” per Section 703.5, Exceptions 1 and 2 cannot be applied. This change provides for the needed clarification to permit FRTW to be used as permitted in Section 602 and 603 in conjunction with a NFPA 285 compliant water-resistive barrier.

Cost Impact

The code change proposal will not increase or decrease the cost of construction .

Potential construction savings where FRTW use was denied due to existence of a combustible water-resistive barrier.

Internal ID: 2058

FS104-18

IBC: 1402.5

Proponent: Ali Fattah, City of San Diego, representing City of San Diego (afattah@sandiego.gov)

2018 International Building Code

Revise as follows:

1402.5 Vertical and lateral flame propagation. *Exterior walls* on buildings of Type I, II, III or IV construction that are greater than 40 feet (12 192 mm) in height above grade plane and contain a combustible *water-resistive barrier* shall be tested in accordance with and comply with the acceptance criteria of NFPA 285. For the purposes of this section, *fenestration* products, flashing of *fenestration* products and *water-resistive-barrier* flashing and accessories at other locations, including through wall flashings, shall not be considered part of the *water-resistive barrier*.

Exceptions:

1. Walls in which the *water-resistive barrier* is the only combustible component and the *exterior wall* has a wall covering of brick, concrete, stone, terra cotta, stucco or steel with minimum thicknesses in accordance with Table 1404.2.
2. Walls in which the *water-resistive barrier* is the only combustible component and the *water-resistive barrier* has a peak heat release rate of less than 150 kW/m², a total heat release of less than 20 MJ/m² and an effective heat of combustion of less than 18 MJ/kg as determined in accordance with ASTM E1354 and has a flame spread index of 25 or less and a smoke-developed index of 450 or less as determined in accordance with ASTM E84 or UL 723. The ASTM E1354 test shall be conducted on specimens at the thickness intended for use, in the horizontal orientation and at an incident radiant heat flux of 50 kW/m².
3. Exterior walls on buildings of Type III construction in which the water-resistive barrier is installed directly on exterior gypsum sheathing and the exterior wall has a wall covering of adhered veneer or stucco applied directly to the water-resistive barrier.

Reason:

The IBC requires that exterior walls incorporating combustible water-resistive barriers in buildings higher than 40 ft and constructed of Type I, I, III or IV construction be tested to NFPA 285. Grade building paper has not been tested, Type V buildings can have a height that exceeds 40 ft and are not addressed. All the wall assemblies listed do not incorporate wood studs. The proposed code change ensures that the ignition of the water resistive barrier will not be caused by ignition of the combustible sheathing such as OSB or plywood. Section 703.5.2 conceptually addresses this issue similarly to that where a thin material is laminated on a non-combustible material can be considered non-combustible if it meets a flame spread rating. Exception 1 in Section 1402.5 also recognizes the benefit of the combustible water resistive barrier in a non-combustible wall. Similarly this code change recognize that the ignition potential for a combustible water resistive barrier sandwiched between two non-combustible sheathing materials or plaster without flue space is very limited. While there may be drainage planes between the stucco and the water resistive barrier the flue space is small enough to be negligible.

We have received several alternate methods and materials requests to utilize Grad D paper in lieu of listed proprietary water resistive barriers since the generic legacy material has not been tested ad all the listed wall assemblies are listed on metal framing. We have also reviewed fire analysis of heat release rates, time to ignition and various other parameters comparing the legacy material to the proprietary materials and they appear to have comparable properties and as a result chose to not include Type V buildings permitted to have a height in excess of 40 ft to this code change.

Cost Impact

The code change proposal will not increase or decrease the cost of construction .

This proposed code change provides an option that does not require the use of proprietary water resistive barriers.

Internal ID: 933

FS105-18

IBC: 1402.5

Proponent: Benjamin Meyer, representing self (2ben.meyer@gmail.com)

2018 International Building Code

Revise as follows:

1402.5 Vertical and lateral flame propagation. *Exterior walls* on buildings of Type I, II, III or IV construction that are greater than 40 feet (12 192 mm) in height above grade plane and contain a combustible *water-resistive barrier* shall be tested in accordance with and comply with the acceptance criteria of NFPA 285. For the purposes of this section, *fenestration* products, flashing of *fenestration* products and *water-resistive-barrier* flashing and accessories at other locations, including through wall flashings, shall not be considered part of the *water-resistive barrier*.

Exceptions:

1. Walls in which the *water-resistive barrier* is the only combustible component and the *exterior wall* has a wall covering of brick, concrete, stone, terra cotta, stucco or steel with minimum thicknesses in accordance with Table 1404.2.
2. Walls in which the *water-resistive barrier* is the only combustible component and the *water-resistive barrier* has a peak heat release rate of less than 150 kW/m², a total heat release of less than 20 MJ/m² and an effective heat of combustion of less than 18 MJ/kg as determined in accordance with ASTM E1354 and has a flame spread index of 25 or less and a smoke-developed index of 450 or less as determined in accordance with ASTM E84 or UL 723. The ASTM E1354 test shall be conducted on specimens at the thickness intended for use, in the horizontal orientation and at an incident radiant heat flux of 50 kW/m².
3. Water-resistive barriers complying with Section 703.5.2.

Reason:

The reference code section can be applied to a WRB material on certain substrates. This exception simplifies other exceptions in the WRB section, while still meeting the stringency and intent of non-combustibility.

Cost Impact

The code change proposal will not increase or decrease the cost of construction .

Alternate compliance and testing method which already exists in the code.

Internal ID: 2391

FS106-18

IBC: 1403.2

Proponent: Jay Crandell, P.E., ARES Consulting, representing Foam Sheathing Committee of the American Chemistry Council

2018 International Building Code

Revise as follows:

1403.2 Water-resistive barrier. Not fewer than one layer of No.15 asphalt felt ,complying with ASTM D226 for Type 1 felt, or other *approved* materials, shall provide a continuous water-resistive barrier behind the exterior wall veneer. No.15 asphalt felt shall be attached to the studs or sheathing and applied horizontally with the upper layer lapped over the lower layer not less than 2 inches (51 mm). Where vertical joints occur, No.15 asphalt felt shall be lapped not less than 6 inches (152 mm). Other approved water-resistive barrier materials shall be installed in accordance with the water-resistive barrier manufacturer's installation instructions. The No.15 asphalt felt or other approved water-resistive barrier material shall be continuous to the top of walls and terminated at penetrations and building appendages with flashing as described in Section 1404.4, in such a manner as to provide a continuous-1404.4. The water-resistive barrier behind the exterior wall veneer installation shall comply with the requirements for weather protection of the exterior wall envelope as described in Section 1402.2.

Reason:

This proposal better correlates the IBC with language in the 2018 IRC (Section R703.2) that provides additional clarity of intent and requirements. In particular, IBC Section 1403.2 is missing basic minimum installation requirements for No.15 asphalt felt. In addition, the 2018 IRC recognizes that other approved materials must be installed in accordance with the manufacturer's installation instructions since they often or necessarily vary from the basic minimum installation requirements for No.15 asphalt felt. Finally, the last phrase of the existing paragraph has been incorporated in the first sentence because it relates to the overall objective of the paragraph and should not be an afterthought.

Cost Impact

The code change proposal will not increase or decrease the cost of construction .

The code change proposal clarifies the provision and correlates with similar language in the IRC with no change in requirements or cost.

Internal ID: 984

FS107-18

IBC: 1403.2

Proponent: John Woestman, Kellen Co., representing Extruded Polystyrene Foam Association (XPSA)
(jwoestman@kellencompany.com)

2018 International Building Code

Revise as follows:

1403.2 Water-resistive barrier. Not fewer than one layer of No.15 asphalt felt, complying with ASTM D226 for Type 1 felt or other *approved* materials, shall be attached to the studs or sheathing, with flashing as described in Section 1404.4, in such a manner as to provide a continuous *water-resistive barrier* behind the *exterior wall veneer*. Other approved water-resistive barrier materials shall be installed in accordance with the water-resistive barrier manufacturer's installation instructions.

Reason:

This proposal adds a sentence that was added to the 2018 IRC (Section R703.2) but was not coordinated with the 2018 IBC. The purpose is to ensure that, for alternative water-resistive barrier materials, the manufacturer's installation instructions are the basis for installation as they may necessarily vary from the typical minimum installation practice used for Type 1 felt.

Cost Impact

The code change proposal will not increase or decrease the cost of construction .

This proposal is a clarification and does not add cost.

Internal ID: 986

FS108-18

IBC: 1403.2

Proponent: Joseph Lstiburek, representing Self (joe@buildingscience.com)

2018 International Building Code

Revise as follows:

1403.2 Water-resistive barrier. Not fewer than one layer of No.15 asphalt felt, complying with ASTM D226 for Type 1 felt or other *approved* materials with a water resistance complying with ASTM E2556, Type I, shall be attached to the studs or sheathing, with flashing as described in Section 1404.4, in such a manner as to provide a continuous *water-resistive barrier* behind the *exterior wall* veneer.

Reason:

The existing code language gives insufficient guidance for other approved materials. The added language addresses this issue and provides a specific performance requirement for water resistance and provides consistency with other sections of the code that relate specifically to water-resistive barriers.

Cost Impact

The code change proposal will not increase or decrease the cost of construction .

This change gives better guidance for water resistance.

Internal ID: 1319

FS109-18

IBC: 1403.3

Proponent: William Hall, Portland Cement Association, representing Alliance For Concrete Codes and Standards (jhall@cement.org); Jason Thompson, National Concrete Masonry Association, representing Masonry Alliance for Codes and Standards (jthompson@ncma.org)

2018 International Building Code

Revise as follows:

[BS] 1403.3 Wood. *Exterior walls* of wood construction shall be designed and constructed in accordance with Chapter 23- and Section 1402.5.

Reason:

This proposal is intended to clarify the code by adding a pointer back to Section 1402.5 to require NFPA 285 testing on construction types other than Type V greater than 40ft. in height which incorporate a combustible water resistive barrier.

Cost Impact

The code change proposal will not increase or decrease the cost of construction .

This provision is currently required in the code.

Internal ID: 616

FS110-18

IBC: 1403.8

Proponent: Michael O'Brian, Chair, representing FCAC (FCAC@iccsafe.org)

2018 International Building Code

Revise as follows:

1403.8 ~~Plastics.~~ Plastic construction elements. ~~Plastic panel, apron or spandrel walls as defined in this code~~ construction elements of the exterior wall envelope, including aprons, panels and spandrels shall not be limited in thickness, provided that such plastics and their assemblies conform to the applicable requirements of Chapter 26 and are constructed of *approved* weather-resistant materials of adequate strength to resist the wind loads for cladding specified in Chapter 16. Plastic spandrel walls shall also comply with the applicable requirements of section 715.5. Light transmitting plastic wall panels shall comply with Section 2607.

Reason:

This code change proposal is intended to clarify the requirements for plastic construction elements in exterior walls. This section is confusing as currently written.

Section 1404.8 does not address plastics in general, but does contain some requirements for specific plastic construction elements on exterior walls. The following terms are not defined in the IBC code: plastic panels, plastic aprons and plastic spandrel walls. The only reference to spandrel walls (and not specifically to plastic spandrel walls) is in section 715.5. Plastic panels are not mentioned in the code, except for light transmitting plastic wall panels that are referenced in section 2607.

In view of the fact that the section as written is confusing, this proposal will serve to clarify the requirements for better understanding by designers and building code officials, without changing requirements.

This proposal is submitted by the ICC Fire Code Action Committee (FCAC). The FCAC was established by the ICC Board of Directors to pursue opportunities to improve and enhance assigned International Codes with regard to fire safety and hazardous materials in new and existing buildings and facilities and the protection of life and property in wildland urban interface areas. In 2017 the Fire-CAC has held 3 open meetings. In addition, there were numerous conference calls, Regional Work Group and Task Group meetings for the current code development cycle, which included members of the committees as well as any interested parties, to discuss and debate the proposed changes. Related documentation and reports are posted on the FCAC website at: <https://www.iccsafe.org/codes-tech-support/cs/fire-code-action-committee-fcac/>

This proposal is one in a series of related proposals intended to address different technical changes to Chapter 14. While the Fire Code Committee will consider each proposal independently, the intent is for approval of all proposals in this package which have been submitted as a correlated set of companion code change proposals.

The FCAC analyzed several fatal fires related to exterior façade/curtain wall fires in the development of these new code requirements. The intent of these proposals is to provide a reasonable set of code requirements to ensure fire safety and weather protection for buildings that utilize combustible materials and/or assemblies for the building exterior wall envelope.

1. Grenfell fire, London England:

Buildings Across U.S. Are Wrapped in Same Panels That Fueled Deadly London Fire: <https://www.wsj.com/articles/built-to-burn-thousands-of-buildings-world-wide-are-wrapped-in-combustible-panels-1508858048>

Why Grenfell Tower Burned: Regulators Put Cost Before Safety
<https://www.nytimes.com/2017/06/24/world/europe/grenfell-tower-london-fire.html>

2. Torch Tower Fire, Dubai

https://en.wikipedia.org/wiki/The_Marina_Torch January 8th, 2018

3. Address Hotel Fire, Dubai https://en.wikipedia.org/wiki/The_Address_Downtown_Dubai January 8th, 2018

Cost Impact

The code change proposal will not increase or decrease the cost of construction .

This proposal simply clarifies the section for better use and understanding.

Internal ID: 389

FS111-18

IBC: 1403.12

Proponent: Michael O'Brian, Chair, representing FCAC (FCAC@iccsafe.org)

2018 International Building Code

Revise as follows:

1403.12 Polypropylene siding. *Polypropylene siding* shall be certified and labeled as conforming to the requirements of ASTM D7254 and those of Section 1403.12.1 or 1403.12.2 by an approved quality control agency. *Polypropylene siding* shall be limited to buildings of Type VB construction and shall be installed in accordance with the requirements of Section 1404.18 and ~~in accordance with the~~ manufacturer's instructions. *Polypropylene siding* shall be secured to the building so as to provide weather protection for the *exterior walls* of the building.

Reason:

This proposal limits the use of Polypropylene siding to only buildings of Type VB construction and adds back language that was inadvertently removed during the last code cycle.

Polypropylene siding is permitted in the code by section 1403.12, which requires it to meet ASTM D7254. The fire test in ASTM D7254 is ASTM E84 and polypropylene siding typically materials melt and fall to the floor of the tunnel during the test before the flame reaches the test specimen, which means that the flame spread index determined is not a valid test result.

Polypropylene siding is a product with very poor fire performance, something that has been demonstrated time after time. For example, the heat release rate of the polypropylene material typically used for polypropylene siding is about twice as high as that of typical wood siding and over twice as high as that of vinyl siding. The heat released by a material used in the outside of a building is an indication of the radiated heat to a nearby building.

Siding tests using ASTM E1354 fire test:

Wood (cedar) siding: peak heat release rate 309 kW/m - effective heat of combustion: 13 MJ/kg

Polypropylene siding 1: peak heat release rate 546 kW/m - effective heat of combustion: 25 MJ/kg

Polypropylene siding 2: peak heat release rate 878 kW/m - effective heat of combustion: 32 MJ/kg

Material tests using ASTM E1354 fire test:

Vinyl (PVC): peak heat release rate 190 kW/m - effective heat of combustion: 9 MJ/kg

For that reason, the use of this material has been limited to Type VB construction since it was first allowed into the IBC. When polypropylene siding burns it releases much more heat than any other siding material permitted by the code.

The difference between Type VB construction and no limits on the Type of construction, allows construction with greater heights, more stories above grade plane and larger allowable areas as well as allowing in buildings of Types I through IV construction. The text proposed to be added by this proposal was deleted at the last cycle with the rationale that this section simply addresses wind speeds. However, the permission for using polypropylene siding in any type of construction applies to the entire chapter.

Note also that the fire separation distance for polypropylene siding is 10 feet (as opposed to 5 feet for other materials) due to its poorer fire performance.

This proposal is submitted by the ICC Fire Code Action Committee (FCAC). The FCAC was established by the ICC Board of Directors to pursue opportunities to improve and enhance assigned International Codes with regard to fire safety and hazardous materials in new and existing buildings and facilities and the protection of life and property in wildland urban interface areas. In 2017 the Fire-CAC has held 3 open meetings. In addition, there were numerous conference calls, Regional Work Group and Task Group meetings for the current code development cycle, which included members of the committees as well as any interested parties, to discuss and debate the proposed changes. Related documentation and reports are posted on the FCAC website at: <https://www.iccsafe.org/codes-tech-support/cs/fire-code-action-committee-fcac/>

This proposal is one in a series of related proposals intended to address different technical changes to Chapter 14. While the Fire Code Committee will consider each proposal independently, the intent is for approval of all proposals in this package which have been submitted as a correlated set of companion code change proposals.

The FCAC analyzed several fatal fires related to exterior façade/curtain wall fires in the development of these new code requirements. The intent of these proposals is to provide a reasonable set of code requirements to ensure fire safety and weather protection for buildings that utilize combustible materials and/or assemblies for the building exterior wall envelope.

1. Grenfell fire, London England:

Buildings Across U.S. Are Wrapped in Same Panels That Fueled Deadly London Fire: <https://www.wsj.com/articles/built-to-burn-thousands-of-buildings-world-wide-are-wrapped-in-combustible-panels-1508858048>

Why Grenfell Tower Burned: Regulators Put Cost Before Safety
<https://www.nytimes.com/2017/06/24/world/europe/grenfell-tower-london-fire.html>

2. Torch Tower Fire, Dubai

https://en.wikipedia.org/wiki/The_Marina_Torch January 8th, 2018

3. Address Hotel Fire, Dubai https://en.wikipedia.org/wiki/The_Address_Downtown_Dubai January 8th, 2018

Cost Impact

The code change proposal will not increase or decrease the cost of construction .

This proposal corrects the removal of the limitation to Type VB buildings that was inadvertently removed from the code the last cycle.

Internal ID: 388

FS112-18

IBC: 1403.12, 1403.12.2

Proponent: Matthew Dobson, Vinyl Siding Institute, representing Vinyl Siding Institute (mdobson@vinylsiding.org)

2018 International Building Code

Revise as follows:

1403.12 Polypropylene siding. *Polypropylene siding* shall be certified and labeled as conforming to the requirements of ASTM D7254 ~~and those of Section 1403.12.1 or 1403.12.2~~ by an approved quality control agency. Polypropylene siding shall comply with Section 1403.12.1 or 1403.12.2. *Polypropylene siding* shall be installed in accordance with the requirements of Section 1404.18 and in accordance with the manufacturer's instructions. *Polypropylene siding* shall be secured to the building so as to provide weather protection for the *exterior walls* of the building.

1403.12.2 Fire separation distance. ~~The Polypropylene siding shall not be installed on walls with a fire separation distance between a building with polypropylene siding and the adjacent building shall be not of less than 10 5 feet (3048-1524 mm).~~

Reason:

This change does not change the intent of the code but improves then language in the following ways:

-Editorial in first paragraph.

-Makes the requirement more consistent in with the language currently in the IRC.

-Makes it consistent with how the I-codes fundamentally treat fire separation distance, as a measurement to property line and requirements for wall performance. The way the code's is written is confusing and not appropriate. The code does not necessarily measure fire separation distance between buildings except in specific situations. Buildings are definitely not measured with a fire separation distance, this measurement is for walls exclusively in the I-codes.

It's worth looking at the definition:

FIRE SEPARATION DISTANCE. The distance measured from the building face to one of the following:1. The closest interior lot line.2. To the centerline of a street, an alley or public way.3. To an imaginary line between two buildings on the lot.The distance shall be measured at right angles from the face of the wall.

In general this is not a change in requirements and limitations.

Cost Impact

The code change proposal will not increase or decrease the cost of construction .

This change is a clarification of how fire separation is measured and will not have any cost impact.

Internal ID: 834

FS113-18

IBC: 1403.14 (New)

Proponent: Jay Crandell, P.E., ARES Consulting, representing Foam Sheathing Committee of the American Chemistry Council

2018 International Building Code

Add new text as follows:

1403.14 Attachments through Insulation. Exterior wall coverings attached to the building structure through foam plastic insulating sheathing shall comply with the attachment requirements of Section 2603.11, 2603.12, or 2603.13.

Reason:

In the last two code cycles, Chapter 26 was revised to address cladding attachment requirements for cases where the cladding attachments pass through a layer of foam plastic insulating sheathing. However, those revisions occurred during the structural committee hearings (Group B) and did not allow coordination with sections in Chapter 14 assigned to the fire safety committee (Group A). This proposal is a follow-up to ensure that provisions in Chapter 14 which deal with installation of wall coverings are linked to special attachment requirements in three sections of Chapter 26 for cases where cladding attachments must be integrated with use of foam plastic insulating sheathing on the exterior of buildings. The language is added to Section 1403.13 because the referenced requirements are related to use of foam plastic insulation materials and are generally applicable to many cladding types in Section 1404; therefore, this approach avoids redundant references that would otherwise need to occur for each cladding type.

Cost Impact

The code change proposal will not increase or decrease the cost of construction .

This proposal cross references and clarifies application of requirements already in the code.

Internal ID: 980

FS114-18

IBC: 202 (New), 1403.13 (New), Chapter 35

Proponent: Matthew Dobson, VSI, representing Vinyl Siding Institute (mdobson@vinylsiding.org)

2018 International Building Code

SECTION 202 DEFINITIONS

Add new definition as follows:

INSULATED VINYL SIDING. A cladding product, with manufacturer-installed foam plastic insulating material as an integral part of the cladding product, having a thermal resistance of not less than R-2.

Add new text as follows:

1403.13 Insulated vinyl siding. Insulated vinyl siding shall be certified and labeled as conforming to the requirements of ASTM D7793 by an approved quality control agency.

Add new standard(s) follows:

ASTM

ASTM International
100 Barr Harbor Drive, P.O. Box
C700
West Conshohocken PA 19428-
2959
US

D7793-17:

Standard Specification for Insulated Vinyl Siding.

Reason:

This proposal introduces a product category that has been in the market for over 20 years and was standardized over 5 years ago. During the last cycle insulated vinyl siding was not allowed in the IBC (even though it is recognized in the IRC and the Energy Code), and the main reason provided was that the product should be tested as one assembly for flame spread and smoke developed index.

Insulated vinyl siding should be treated the same as any other cladding and insulation products. According to the IBC, cladding does not require flame spread testing or smoke developed index testing, except in applications where the product might be considered an interior finish, e.g. breezeways of apartments. Of course, the foam plastic needs to meet the requirements of Chapter 26 of the IBC and the product standard requires this testing in accordance with the IBC and IRC.

The IBC has provisions in place for cladding when used in certain density settings and when used with non-combustible construction. The previous argument used is not valid because it places additional requirements on one type of cladding product when there are many other cladding systems that would not be required to be tested similarly. Additionally, when insulated vinyl siding needs to be tested as a whole assembly in high density settings, it can pass the E119 test.

Insulated vinyl siding has proven to be safe for the past twenty years, and with this proposal we submit examples of several products approved for use in higher density settings as part of an E119 1-hour rated assembly. Insulated vinyl siding has also been approved for use in urban wildland interface settings in California via the CA SFM 12-7A-1 test. Also submitted is code compliance report where it specifies insulated vinyl siding is allowed for use in the IBC, and has been for years. Information has been included as attachments.

By recognizing the product standard, developed through the ASTM standard making process in 2010-2012, the code is simply staying up-to-date with recognition of the proper standard – providing accurate information to building officials on a well-performing product that also contributes to energy efficiency.

Cost Impact

The code change proposal will decrease the cost of construction .

By adding this reference into the IBC it will help to reduce some of the additional regulatory costs associated with product standards not recognized by the building code.

Analysis: A review of the standard proposed for inclusion in the code, ASTM D7793-17, with regard to the ICC criteria for referenced standards (Section 3.6 of CP#28) will be posted on the ICC website on or before April 2, 2018.

Internal ID: 830

FS115-18

IBC: TABLE 1404.2

Proponent: Jason Thompson, National Concrete Masonry Association, representing Masonry Alliance for Codes and Standards (jthompson@ncma.org)

2018 International Building Code

Revise as follows:

**TABLE 1404.2
MINIMUM THICKNESS OF WEATHER COVERINGS**

COVERING TYPE	MINIMUM THICKNESS (inches)
Adhered masonry veneer	
Architectural cast stone	0.75
Other	0.25
Aluminum siding	0.019
Anchored masonry veneer	
Stone (natural)	2.0
Architectural cast stone	1.25 -2.5
Other	2.625
Asbestos-cement boards	0.125
Asbestos shingles	0.156
Cold-rolled copper ^d	0.0216 nominal
Copper shingles ^d	0.0162 nominal
Exterior plywood (with sheathing)	0.313
Exterior plywood (without sheathing)	See Section 2304.6
Fiber cement lap siding	0.25 ^c
Fiber cement panel siding	0.25 ^c
Fiberboard siding	0.5
Glass-fiber reinforced concrete panels	0.375
Hardboard siding ^c	0.25
High-yield copper ^d	0.0162 nominal
Lead-coated copper ^d	0.0216 nominal
Lead-coated high-yield copper	0.0162 nominal
Marble slabs	1
Particleboard (with sheathing)	See Section 2304.6
Particleboard (without sheathing)	See Section 2304.6
Porcelain tile	0.25
Steel (approved corrosion resistant)	0.0149
Structural glass	0.344
Stucco or exterior cement plaster	
Three-coat work over:	
Metal plaster base	0.875 ^b
Unit masonry	0.625 ^b
Cast-in-place or precast concrete	0.625 ^b
Two-coat work over:	
Unit masonry	0.5 ^b
Cast-in-place or precast concrete	0.375 ^b
Terra cotta (anchored)	1
Terra cotta (adhered)	0.25
Vinyl siding	0.035
Wood shingles	0.375
Wood siding (without sheathing) ^a	0.5

For SI: 1 inch = 25.4 mm, 1 ounce = 28.35 g, 1 square foot = 0.093 m².

- a. Wood siding of thicknesses less than 0.5 inch shall be placed over sheathing that conforms to Section 2304.6.
- b. Exclusive of texture.
- c. As measured at the bottom of decorative grooves.
- d. 16 ounces per square foot for cold-rolled copper and lead-coated copper, 12 ounces per square foot for copper shingles, high-yield copper and lead-coated high-yield copper.

Reason:

Industry standards and recommendations have set the minimum thickness of anchored cast stone veneer at 2.5 inches for decades. This minimum thickness is necessary to ensure there is sufficient engagement of the veneer anchor embedded in the mortar bed joint to provide later support of the veneer as well as provide the necessary cover depth for corrosion protection of the veneer anchor.

Cost Impact

The code change proposal will not increase or decrease the cost of construction .

This change will bring the IBC requirements in line with already established industry standards and practices being used.

Internal ID: 2016

FS116-18

IBC: TABLE 1404.2

Proponent: Jason Thompson, National Concrete Masonry Association, representing Masonry Alliance for Codes and Standards (jthompson@ncma.org)

2018 International Building Code

Revise as follows:

**TABLE 1404.2
MINIMUM THICKNESS OF WEATHER COVERINGS**

COVERING TYPE	MINIMUM THICKNESS (inches)
Adhered masonry veneer	0.25
Architectural cast stone	0.75
Other	0.25
Aluminum siding	0.019
Anchored masonry veneer	2.0
Stone (natural)	1.25
Architectural cast stone	2.625
Other	
Asbestos-cement boards	0.125
Asbestos shingles	0.156
Cold-rolled copper ^d	0.0216 nominal
Copper shingles ^d	0.0162 nominal
Exterior plywood (with sheathing)	0.313
Exterior plywood (without sheathing)	See Section 2304.6
Fiber cement lap siding	0.25 ^c
Fiber cement panel siding	0.25 ^c
Fiberboard siding	0.5
Glass-fiber reinforced concrete panels	0.375
Hardboard siding ^c	0.25
High-yield copper ^d	0.0162 nominal
Lead-coated copper ^d	0.0216 nominal
Lead-coated high-yield copper	0.0162 nominal
Marble slabs	1
Particleboard (with sheathing)	See Section 2304.6
Particleboard (without sheathing)	See Section 2304.6
Porcelain tile	0.25
Steel (approved corrosion resistant)	0.0149
Structural glass	0.344
Stucco or exterior cement plaster	0.875 ^b
Three-coat work over:	0.625 ^b
Metal plaster base	0.625 ^b
Unit masonry	0.5 ^b
Cast-in-place or precast concrete	0.375 ^b
Two-coat work over:	
Unit masonry	
Cast-in-place or precast concrete	
Terra cotta (anchored)	1
Terra cotta (adhered)	0.25
Vinyl siding	0.035
Wood shingles	0.375
Wood siding (without sheathing) ^a	0.5

For SI: 1 inch = 25.4 mm, 1 ounce = 28.35 g, 1 square foot = 0.093 m².

- a. Wood siding of thicknesses less than 0.5 inch shall be placed over sheathing that conforms to Section 2304.6.
- b. Exclusive of texture.
- c. As measured at the bottom of decorative grooves.
- d. 16 ounces per square foot for cold-rolled copper and lead-coated copper, 12 ounces per square foot for copper shingles, high-yield copper and lead-coated high-yield copper.

Reason:

For several years efforts have been underway to standardize the minimum thickness requirements for adhered masonry veneers. While some adhered veneers are thicker than the 0.25 in. minimum for architectural, aesthetic, or manufacturing reasons, this change brings the requirements of Chapter 14 in line with industry practices.

Cost Impact

The code change proposal will not increase or decrease the cost of construction .

This change brings the requirements of Chapter 14 in line with current industry recommendations.

Internal ID: 2017

FS117-18

IBC: 1404.3, , 1404.3(1) (New), 1404.3(2) (New), TABLE 1404.3.2, 1404.3.2, 1404.3.3, 1404.3.4

Proponent: Jay Crandell, P.E., ARES Consulting, representing Foam Sheathing Committee of the American Chemistry Council

2018 International Building Code

Delete without substitution:

~~**1404.3 Vapor retarders.** Vapor retarders as described in Section 1404.3.3 shall be provided in accordance with Sections 1404.3.1 and 1404.3.2, or an approved design using accepted engineering practice for hygrothermal analysis.~~

Revise as follows:

1404.3 Vapor retarders. Vapor retarder materials shall be classified in accordance with Table 1404.3(1). A vapor retarder shall be provided on the interior side of frame walls in accordance with Table 1404.3(2) and Table 1404.3(3), or an approved design using accepted engineering practice for hygrothermal analysis. The appropriate climate zone shall be selected in accordance with Chapter 3 of the International Energy Conservation Code.

~~**1404.3.1 Class I and II vapor retarders.** Class I and II vapor retarders shall not be provided on the interior side of frame walls in Zones 1 and 2. Class I vapor retarders shall not be provided on the interior side of frame walls in Zones 3 and 4 other than Marine 4. Class I or II vapor retarders shall be provided on the interior side of frame walls in Zones 5, 6, 7, 8 and Marine 4. The appropriate zone shall be selected in accordance with Chapter 3 [CE] of the International Energy Conservation Code Commercial Provisions.~~

Exceptions:

1. Basement walls.
2. Below-grade portion of any wall.
3. Construction where moisture accumulation, condensation, or its freezing of moisture will not damage the materials.
4. ~~Conditions where Class III vapor retarders are required in Section 1404.3.2.~~

Add new text as follows:

1404.3(1)

VAPOR RETARDER MATERIALS AND CLASSES

<u>VAPOR RETARDER CLASS</u>	<u>ACCEPTABLE MATERIALS</u>
I	<u>Sheet polyethylene, nonperforated aluminum foil, or other approved materials with a perm rating of less than or equal to 0.1</u>
II	<u>Kraft-faced fiberglass batts, paint, or other approved materials with a perm rating greater than 0.1 and less than or equal to 1.0</u>
III	<u>Latex paint, enamel paint, or other approved materials with a perm rating of greater than 1.0 and less than or equal to 10</u>

TABLE 1404.3(2)
VAPOR RETARDER OPTIONS

CLIMATE ZONE	VAPOR RETARDER CLASS		
	I	II	III ^a
<u>1, 2</u>	<u>Not permitted</u>	<u>Not Permitted</u>	<u>Permitted</u>
<u>3, 4 (except Marine 4)</u>	<u>Not permitted</u>	<u>Permitted</u>	<u>Permitted</u>
<u>Marine 4, 5, 6, 7, 8</u>	<u>Permitted</u>	<u>Permitted</u>	<u>See Table 1404.3(3)</u>

a. Only Class III vapor retarders shall be used on the interior side of frame walls where foam plastic insulating sheathing with a perm rating of less than 1 is applied in accordance with Table 1404.3(3) on the exterior side of the frame wall.

Revise as follows:

**TABLE 1404.3.2 1404.3(3)
CLASS III VAPOR RETARDERS**

ZONE	CLASS III VAPOR RETARDERS PERMITTED FOR:^{a,b}
Marine 4	Vented cladding over wood structural panels Vented cladding over fiberboard Vented cladding over gypsum Continuous insulation with <i>R</i> -value \geq R2.5 over 2 x 4 wall Continuous insulation with <i>R</i> -value \geq R3.75 over 2 x 6 wall
5	Vented cladding over wood structural panels Vented cladding over fiberboard Vented cladding over gypsum Continuous insulation with <i>R</i> -value \geq R5 over 2 x 4 wall Continuous insulation with <i>R</i> -value \geq R7.5 over 2 x 6 wall
6	Vented cladding over fiberboard Vented cladding over gypsum Continuous insulation with <i>R</i> -value \geq R7.5 over 2 x 4 wall Continuous insulation with <i>R</i> -value \geq R11.25 over 2 x 6 wall
7 and 8	Continuous insulation with <i>R</i> -value \geq R10 over 2 x 4 wall Continuous insulation with <i>R</i> -value \geq R15 over 2 x 6 wall

For SI: 1 pound per cubic foot = 16 kg/m³.

- a. Spray foam with a maximum permance of 1.5 perms at the installed thickness applied to the interior cavity side of wood structural panels, fiberboard, insulating sheathing or gypsum is deemed to meet the continuous insulation requirement where the spray foam R-value meets or exceeds the specified insulating sheathing R-value.
- b. Vented cladding shall include vinyl lap siding, polypropylene, or horizontal aluminum siding, brick veneer with clear airspace as specified in this code, and other approved vented claddings.

Delete without substitution:

~~**1404.3.2 Class III vapor retarders.** Class III vapor retarders shall be permitted where any one of the conditions in Table 1404.3.2 is met. Only Class III vapor retarders shall be used on the interior side of frame walls where foam plastic insulating sheathing with a perm rating of less than 1 is applied in accordance with Table 1404.3.2 on the exterior side of the frame wall.~~

~~**1404.3.3 Material vapor retarder class.** The vapor retarder class shall be based on the manufacturer's certified testing or a tested assembly.~~

~~The following shall be deemed to meet the class specified:~~

~~Class I: Sheet polyethylene, nonperforated aluminum foil with a perm rating of less than or equal to 0.1.~~

~~Class II: Kraft faced fiberglass batts or paint with a perm rating greater than 0.1 and less than or equal to 1.0.~~

~~Class III: Latex or enamel paint with a perm rating of greater than 1.0 and less than or equal to 10.0.~~

~~**1404.3.4 Minimum clear airspaces and vented openings for vented cladding.** For the purposes of this section, vented cladding shall include the following minimum clear airspaces:~~

1. ~~Vinyl, polypropylene or horizontal aluminum siding applied over a weather resistive barrier as specified in this chapter.~~
2. ~~Brick veneer with a clear airspace as specified in this code.~~
3. ~~Other approved vented claddings.~~

Reason:

This proposal is a non-technical change to reformat the vapor retarder provisions to make them more transparent and user-friendly. The proposal uses a "look-up" table format whereby the logic for selection of appropriate vapor retarders is more visually obvious and appropriate options are more readily selected for various climate conditions and vapor retarder classes. This proposal is intended to help bring focus on consideration of formatting and editorial improvements while technical changes are addressed in separate proposals.

Cost Impact

The code change proposal will not increase or decrease the cost of construction .

The proposal is a nontechnical format change and therefore has no cost impacts except those that might be associated with improving compliance and enforcement.

Internal ID: 1010

FS118-18

IBC: 1404.3, 1404.3.1

Proponent: Theresa Weston, DuPont, representing Air Barrier Association (theresa.a.weston@dupont.com)

2018 International Building Code

1404.3 Vapor retarders. Vapor retarders as described in Section 1404.3.3 shall be provided in accordance with Sections 1404.3.1 and 1404.3.2, or an approved design using accepted engineering practice for hygrothermal analysis.

Revise as follows:

1404.3.1 Class I and II vapor retarders. Class I and II vapor retarders shall not be provided on the interior side of frame walls in Zones 1 and 2. Class I vapor retarders shall not be provided on the interior side of frame walls in Zones 3 and 4 other than Marine 4. Class I or II vapor retarders shall be provided on the interior side of frame walls in Zones 5, 6, 7, 8 and Marine 4. The appropriate zone shall be selected in accordance with Chapter 3 [CE] of the International Energy Conservation Code-Commercial Provisions.

Exceptions:

1. Basement walls.
2. Below-grade portion of any wall.
3. Construction where moisture or its freezing will not damage the materials.
4. Class I and II vapor retarders with vapor permeability greater than 1 perm when measured by ASTM E96 water method (Procedure B) shall be allowed on the interior side of any frame wall in all climate zones.
- 4-5. Conditions where Class III vapor retarders are required in Section 1404.3.2.

Reason:

This proposal recognizes that some vapor retarders (both traditional and new materials) do not fit neatly into categories that are defined by Procedure A (dessicant method) vapor permeability measurements alone. The prohibition against the use of specific vapor retarder classes in specific climate zones is based on providing assemblies with the ability to dry to the interior. However, if a vapor retarder has vapor permeability that increases with relative humidity (RH) to a class III level, it has been shown that it allows drying. Therefore, these materials should not be prohibited. A list of references which demonstrate the improved drying using these types of materials is shown below.

Bibliography:

1. Mukhopadhyaya, P et. Al., "Accelerated Aging Performance Evaluation of "Smart Vapor Retarder"", Thermal Performance of the Exterior Envelopes of Whole Buildings International Conference XI, Clearwater, FL, December 2010
2. Gatland, Stanley D., "Vapor Retarders Play Crucial Role in Building Envelope Moisture Management Strategies", Interface, April 2010
3. Ueno, Kohta et al, "Field Monitoring of Wall Vapor Control Strategies in the Pacific Northwest", ACEEE Summer Study on Energy Efficiency in Buildings, 2008
4. Gatland Stanley D., Il e.g. all, "The Hygrothermal Performance of Wood-Framed Wall Systems Using a Relative Humidity-Dependent Vapor Retarder in the Pacific Northwest", Thermal Performance of the Exterior Envelopes of Whole Buildings International Conference XI, Clearwater, FL, December 2007
5. Overton, G.E. (2016). Vapour Control in New Zealand Walls. Study Report SR344, BRANZ Ltd, Judgeford, New Zealand.
6. Kunzel, Hartwig M., "Flexible Vapor Control Solves Moisture Problems of Building Assemblies - Smart Retarder to Replace the Conventional PE-Film", J Thermal Envelope & Building Science, Vol. 23 (July 1999), pp 95 - 102.
7. Geving, Stig, PhD. et al, "Smart Vapour Barriers in Compact Wood Frame Roofs", Thermal Performance of the Exterior Envelopes of Whole Buildings International Conference XII Clearwater, FL, December 2013
8. Kunzel, Hartwig M., "More Moisture Load Tolerance of Construction Assemblies Through the Application of a Smart Vapor Retarder", Thermal Performance of the Exterior Envelopes of Whole Buildings International Conference VII, Clearwater, FL, December 1998

Cost Impact

The code change proposal will not increase or decrease the cost of construction .

This proposal will not increase the cost of construction because it does not add any new requirements or restrictions. It provides additional options to meet the code.

Internal ID: 2045

FS119-18

IBC: 1404.3, 1404.3.1, 1404.3.2, 1404.3.3, TABLE 1404.3.3

Proponent: Kingston Chow, APA - The Engineered Wood Association, representing APA - The Engineered Wood Association (kingston.chow@apawood.org); Borjen Yeh, APA - The Engineered Wood Association, representing APA - The Engineered Wood Association (borjen.yeh@apawood.org)

2018 International Building Code

Revise as follows:

1404.3 Vapor retarders. Vapor retarders as described in Section ~~1404.3.3~~1404.3.1 shall be provided in accordance with Sections ~~1404.3.1~~1404.3.2 and ~~1404.3.2~~1404.3.3, or an approved design using accepted engineering practice for hygrothermal analysis.

~~1404.3.3~~1404.3.1 **Material vapor retarder class.** The *vapor retarder class* shall be based on the manufacturer's certified testing or a tested assembly.

The following shall be deemed to meet the class specified:

Class I: Sheet polyethylene, nonperforated aluminum foil with a perm rating of less than or equal to 0.1.

Class II: Kraft-faced fiberglass batts or paint with a perm rating greater than 0.1 and less than or equal to 1.0.

Class III: Latex or enamel paint with a perm rating of greater than 1.0 and less than or equal to 10.0.

~~1404.3.1~~1404.3.2 **Class I and II vapor retarders.** Class I and II vapor retarders shall not be provided on the interior side of frame walls in Zones 1 and 2. Class I vapor retarders shall not be provided on the interior side of frame walls in Zones 3 and 4 other than Marine 4. Class I or II vapor retarders shall be provided on the interior side of frame walls in Zones 5, 6, 7, 8 and Marine 4. The appropriate zone shall be selected in accordance with Chapter 3 [CE] of the International Energy Conservation Code-Commercial Provisions.

Exceptions:

1. Basement walls.
2. Below-grade portion of any wall.
3. Construction where moisture or its freezing will not damage the materials.
4. Conditions where Class III vapor retarders are required in Section ~~1404.3.2~~1404.3.3.

~~1404.3.2~~1404.3.3 **Class III vapor retarders.** Class III vapor retarders shall be permitted where any one of the conditions in Table ~~1404.3.2~~1404.3.3 is met. Only Class III vapor retarders shall be used on the interior side of frame walls where foam plastic insulating sheathing with a perm rating of less than 1 is applied in accordance with Table ~~1404.3.2~~1404.3.3 on the exterior side of the frame wall.

**TABLE 1404.3-21404.3.3
CLASS III VAPOR RETARDERS**

ZONE	CLASS III VAPOR RETARDERS PERMITTED FOR:^a
Marine 4	Vented cladding over wood structural panels Vented cladding over fiberboard Vented cladding over gypsum Continuous insulation with <i>R</i> -value \geq R2.5 over 2 × 4 wall Continuous insulation with <i>R</i> -value \geq R3.75 over 2 × 6 wall
5	Vented cladding over wood structural panels Vented cladding over fiberboard Vented cladding over gypsum Continuous insulation with <i>R</i> -value \geq R5 over 2 × 4 wall Continuous insulation with <i>R</i> -value \geq R7.5 over 2 × 6 wall
6	Vented cladding over fiberboard Vented cladding over gypsum Continuous insulation with <i>R</i> -value \geq R7.5 over 2 × 4 wall Continuous insulation with <i>R</i> -value \geq R11.25 over 2 × 6 wall
7 and 8	Continuous insulation with <i>R</i> -value \geq R10 over 2 × 4 wall Continuous insulation with <i>R</i> -value \geq R15 over 2 × 6 wall

For SI: 1 pound per cubic foot = 16 kg/m³.

- a. Spray foam with a maximum permanence of 1.5 perms at the installed thickness applied to the interior cavity side of wood structural panels, fiberboard, insulating sheathing or gypsum is deemed to meet the continuous insulation requirement where the spray foam *R*-value meets or exceeds the specified insulating sheathing *R*-value.

Reason:

This proposal is a non-technical change to reorder the original section 1404.3.3 Material vapor retarder class, which describes the three different vapor retarder classes before the original sections 1404.3.1 Class I and II vapor retarders and 1404.3.2 Class III vapor retarders. The proposal is intended to help bring clarity by introducing the three vapor retarder classes before outlining the restrictions in vapor retarder usage for the different climate zones as provided in the original sections 1404.3.1 and 1404.3.2.

Cost Impact

The code change proposal will not increase or decrease the cost of construction .

This change proposal is editorial with no technical change in content.

Internal ID: 1709

FS120-18

IBC: 1404.3.1, TABLE 1404.3.1 (New), 1404.3.2

Proponent: Jay Crandell, P.E., ARES Consulting, representing Foam Sheathing Committee of the American Chemistry Council (jcrandell@aresconsulting.biz); Vladimir Kochkin, representing Home Innovation Research Labs (vkochkin@homeinnovation.com)

2018 International Building Code

Revise as follows:

1404.3.1 Class I and II vapor retarders. Class I and II vapor retarders shall not be provided on the interior side of frame walls in Zones 1 and 2. Class I vapor retarders shall not be provided on the interior side of frame walls in Zones 3 and 4 other than Marine 4. Class I or II vapor retarders shall be provided on the interior side of frame walls in Zones 5, 6, 7, 8 and Marine 4. Where a Class II vapor retarder is used in combination with foam plastic insulating sheathing installed as continuous insulation on the exterior side of frame walls, the continuous insulation shall comply with Table 1404.3.1. Use of a Class I interior vapor retarder in frame walls with a Class I vapor retarder on the exterior side shall require an approved design. The appropriate zone shall be selected in accordance with Chapter 3 [CE] of the International Energy Conservation Code-Commercial Provisions.

Exceptions:

1. Basement walls.
2. Below-grade portion of any wall.
3. Construction where moisture or its freezing will not damage the materials.
4. Conditions where Class III vapor retarders are ~~required~~ permitted in Section 1404.3.2.

Add new text as follows:

**TABLE 1404.3.1
CONTINUOUS INSULATION WITH CLASS II VAPOR RETARDER**

CLIMATE ZONE	PERMITTED CONDITIONS ^a
3	Continuous insulation with R-value ≥ 2 .
4, 5, and 6	Continuous insulation with R-value ≥ 3 over 2x4 wall. Continuous insulation with R-value ≥ 5 over 2x6 wall.
7	Continuous insulation with R-value ≥ 5 over 2x4 wall. Continuous insulation with R-value ≥ 7.5 over 2x6 wall.
8	Continuous insulation with R-value ≥ 7.5 over 2x4 wall. Continuous insulation with R-value ≥ 10 over 2x6 wall.

a. In addition to the vapor retarder, spray foam with a maximum permeance of 1.5 perms at the installed thickness, applied to the interior cavity side of wood structural panels, fiberboard, insulating sheathing or gypsum is deemed to comply with the continuous insulation requirement only for the moisture control purposes of this table where the spray foam R-value plus any continuous insulation R-value provided equals or exceeds the specified continuous insulation R-value.

Revise as follows:

1404.3.2 Class III vapor retarders. ~~Class III vapor retarders shall be permitted where any one of the conditions in Table 1404.3.2 is met. Only Class III vapor retarders shall be used on the interior side of frame walls where foam plastic insulating sheathing with a perm rating of less than 1 is applied in accordance with Table 1404.3.2 on the exterior side of the frame wall.~~

Reason:

As its primary objective, this proposal restores the ability to appropriately use a Class II interior vapor retarder where foam plastic insulating sheathing is used as continuous insulation on the exterior of buildings. This was permitted in earlier editions of the IBC, but not with appropriate requirements as now included in this proposal. This proposal has two practical benefits. First, it will better coordinate the requirements for vapor retarders with typical insulation requirements found in the International Energy Conservation Code for frame wall assemblies. Second, the proposed requirements in Table 1404.3.1 are identical to the format used in in existing Table 1404.3.2 for ease of use and compliance. They provide assurance that an adequate amount of continuous insulation is used together with a Class II interior vapor retarder to keep the interior of walls sufficiently warm (temperature moderated) to control the risk of condensation and moisture accumulation.

The continuous insulation requirements of proposed Table 1404.3.1 are based on more than 20-years of successful experience in the National Building Code of Canada as well as an extensive review of research, field data, analyses, and code requirements in the U.S. and Canada (ABTG, 2015; Crandell 2017); refer to the bibliography.

Use of a Class II interior vapor retarder with foam sheathing on the exterior has been shown to provide a very stable and dry wall assembly. In addition to the research and experience mentioned above, this has been more recently confirmed in a DOE and industry sponsored research project where various wall assemblies in 22 buildings across the colder climate zones of the U.S. were monitored for moisture performance (Shah and Kochkin, 2017). Regarding the use of Class II (e.g., Kraft paper) vapor retarders, the report found "very stable moisture content levels" and that their use "does not seem to alter the ability of walls with exterior foam sheathing to dry out." Consequently, the report recommends the "combination of exterior insulation and a Class II vapor retarder show promise as a technology for increased R-value with minimal changes in construction practices."

Finally, while there is adequate experience in the colder climates of the U.S. and Canada to justify use of a Class I interior vapor retarder (e.g., 4 mil poly) with foam plastic insulating sheathing on the exterior side of an assembly, this proposal requires an approved design for the case of a double vapor barrier assembly (e.g., materials classified as a Class I vapor retarder are used on both sides of the assembly). The National Building Code of Canada does permit the use of a Class I interior vapor retarder with low-perm foam plastic exterior insulation and requires provisions similar to those provided in proposed Table 1404.3.1. Furthermore, the study mentioned above also demonstrates that use of a Class I interior vapor retarder on walls with or without exterior insulation "show stable low moisture content levels" (Shah and Kochkin, 2017). But, due to concerns with low drying potential, it is generally cautioned that walls using a double vapor barrier (Class I vapor retarder on both sides) be "accompanied with air sealing details and drainage plane details to avoid or minimize the potential for water leaks or moisture accumulation" (Shah and Kochkin, 2017). Thus, while known to work favorably in appropriate conditions of use, the use of a double vapor barrier assembly may require some additional considerations to ensure performance and this should be a matter of design as required in this proposal.

Bibliography:

- Assessment of Water Vapor Control Methods for Modern Insulated Light-Frame Wall Assemblies, ABTG Research Report No. 1410-03, 2015, Applied Building Technology Group LLC, <https://www.appliedbuildingtech.com/rrr/1410-03>
- Assessment of Hygrothermal Performance and Design Guidance for Modern Light-Frame Wall Assemblies, ASTM STP 1599, Crandell, J.H., 2017, https://www.astm.org/DIGITAL_LIBRARY/STP/PAGES/STP159920160097.htm
- Moisture Performance of High-R Wall Systems, Prepared for US DOE & NAHB by Home Innovation Research Labs, Kochkin, V. and Shah, N., 2017 (pending publication)

Cost Impact

The code change proposal will decrease the cost of construction .

Including the option to use a Class II vapor retarder with foam plastic insulating sheathing (or a Class I vapor retarder

with an approved design) will decrease cost and better enable cost-effective compliance with energy code requirements while maintaining good moisture performance.

Internal ID: 1014

FS121-18

IBC: 1404.3.1, 1404.3.2

Proponent: Mike Fischer, Kellen Company, representing The Polyisocyanurate Insulation Manufacturers Association (mfischer@kellencompany.com)

2018 International Building Code

Revise as follows:

1404.3.1 Class I and II vapor retarders. Class I and II vapor retarders shall not be provided on the interior side of frame walls in Zones 1 and 2. Class I vapor retarders shall not be provided on the interior side of frame walls in Zones 3 and 4 other than Marine 4. Class I or II vapor retarders shall be provided on the interior side of frame walls in Zones 5, 6, 7, 8 and Marine 4. The appropriate zone shall be selected in accordance with Chapter 3 [CE] of the International Energy Conservation Code-Commercial Provisions.

Exceptions:

1. Basement walls.
2. Below-grade portion of any wall.
3. Construction where moisture or its freezing will not damage the materials.
4. ~~Conditions where Class III vapor retarders are required in Section 1404.3.2.~~

1404.3.2 Class III vapor retarders. Class III vapor retarders shall be permitted ~~where for~~ any one of the conditions in Table 1404.3.2 ~~is met. Only Class III vapor retarders shall be used on the interior side of frame walls where foam plastic insulating sheathing with a perm rating of less than 1 is applied in accordance with Table 1404.3.2 on the exterior side of the frame wall walls.~~

Reason:

The clauses proposed for deletion were originally added to the code as an interim conservative measure while appropriate use of Class I and II vapor retarders on walls with foam plastic insulating sheathing were more thoroughly investigated. Now, an extensive review of data, analyses, and experience has been completed (refer to bibliography). The findings indicate that the concern with appropriate use of Class I and II vapor retarders concern is mainly a concern for walls without temperature moderation as provided by continuous insulation. Field data and analyses from several studies have demonstrated successful use of Class I and II vapor retarders on walls with exterior foam sheathing used as continuous insulation. As further confirmation, this method has been successfully used in Canada and explicitly recognized in the National Building Code of Canada since the 1995 edition. In addition, this proposal will make the IBC provisions consistent with the IRC provisions which were not changed to require use of only Class III vapor retarders with foam sheathing. Thus, this proposal will restore consistency between the IBC and IRC. It also simplifies the code.

Bibliography:

Assessment of Hygrothermal Performance and Design Guidance for Modern Light-Frame Wall Assemblies, ASTM STP1599, J. H. Crandell, 2017, pp.362-394, https://www.astm.org/DIGITAL_LIBRARY/STP/PAGES/STP159920160097.htm

Assessment of Water Vapor Control Methods for Modern Insulated Light-Frame Wall Assemblies, ABTG Research Report No. 1410-03, Applied Building Technology Group LLC, 2015, <https://www.appliedbuildingtech.com/rr/1410-03>

Cost Impact

The code change proposal will decrease the cost of construction .

This proposal will allow (actually restore) vapor retarder options that provide at least equivalent performance for water vapor control at a lower cost than would occur where Class III vapor retarders are currently required to be used.

Internal ID: 1013

FS122-18

IBC: 1404.3.2, 1404.3.2.1 (New), 1404.3.2.2 (New), 1404.3.2.2.1 (New), TABLE 1404.3.2

Proponent: Mike Fischer, Kellen Company, representing The Center for the Polyurethanes Industry of the American Chemistry Council (mfischer@kellencompany.com)

2018 International Building Code

Revise as follows:

1404.3.2 Class III vapor retarders. Class III vapor retarders shall be permitted where any one of the conditions in Table 1404.3.2 is met. ~~Only Class III vapor retarders shall be used on the interior side of frame walls where foam plastic insulating sheathing with a perm rating of less than 1 is applied in accordance with Table 1404.3.2 on the exterior side of the frame wall.~~

Add new text as follows:

1404.3.2.1 Foam plastic insulating sheathing for moisture control with Class III vapor retarders. .

Where foam plastic insulating sheathing with a perm rating of less than 1 is installed in accordance with Table 1404.3.2 on the exterior side of the frame wall, only Class III vapor retarders shall be used on the interior side of the frame wall.

1404.3.2.2 Spray foam plastic insulation for moisture control with Class III vapor retarders. . For purposes of compliance with Table 1404.3.2, spray foam with a maximum permeance of 1.5 perms at the installed thickness applied to the interior cavity side of wood structural panels, fiberboard, insulating sheathing or gypsum shall be deemed to meet the continuous insulation R-value requirement where the spray foam R-value meets or exceeds the specified continuous insulation R-value.

1404.3.2.2.1 Hybrid insulation for moisture control with Class III vapor retarders. . For the purposes of compliance with Table 1404.3.2, the combined R-values of spray foam plastic insulation and continuous insulation shall be permitted to be counted towards the continuous R-value requirement.

Revise as follows:

**TABLE 1404.3.2
CLASS III VAPOR RETARDERS**

ZONE	CLASS III VAPOR RETARDERS PERMITTED FOR:^a
Marine 4	Vented cladding over wood structural panels Vented cladding over fiberboard Vented cladding over gypsum Continuous insulation with R-value \geq R2.5 over 2 x 4 wall Continuous insulation with R-value \geq R3.75 over 2 x 6 wall
5	Vented cladding over wood structural panels Vented cladding over fiberboard Vented cladding over gypsum Continuous insulation with R-value \geq R5 over 2 x 4 wall Continuous insulation with R-value \geq R7.5 over 2 x 6 wall
6	Vented cladding over fiberboard Vented cladding over gypsum Continuous insulation with R-value \geq R7.5 over 2 x 4 wall Continuous insulation with R-value \geq R11.25 over 2 x 6 wall
7 and 8	Continuous insulation with R-value \geq R10 over 2 x 4 wall Continuous insulation with R-value \geq R15 over 2 x 6 wall

For SI: 1 pound per cubic foot = 16 kg/m³.

~~a. Spray foam with a maximum permeance of 1.5 perms at the installed thickness applied to the interior cavity side of wood structural panels, fiberboard, insulating sheathing or gypsum is deemed to meet the continuous insulation requirement where the spray foam R-value meets or exceeds the specified insulating sheathing R-value.~~

Reason:

The current Table 1404.3.2 mandates continuous insulation for moisture control but provides an exception for spray foam in the cavity. The table does not currently permit a combination of continuous and cavity; this is inconsistent with the intent of the cavity option. Additionally, with prescriptive options in the IECC including hybrid insulation systems with a combination of cavity and continuous, this will help correlate the IBC and IECC requirements. The proposal adds clarifying language that clarifies how the combination of different insulating methods can provide appropriate moisture control so that the total required R-Value can be achieved by continuous, cavity, or a combination of insulation strategies.

Cost Impact

The code change proposal will decrease the cost of construction .

By adding options for insulation used to control moisture and condensation, the proposal increases flexibility which will include lower cost options.

Internal ID: 2387

FS123-18

IBC: 1404.3.2

Proponent: Jay Crandell, P.E., ARES Consulting, representing Foam Sheathing Committee of the American Chemistry Council (jcrandell@aresconsulting.biz)

2018 International Building Code

Revise as follows:

1404.3.2 Class III vapor retarders. Class III vapor retarders shall be permitted in Climate Zones 1 through 3 and where any one of the conditions in Table 1404.3.2 is met. Only Class III vapor retarders shall be used on the interior side of frame walls where foam plastic insulating sheathing with a perm rating of less than 1 is applied in accordance with Table 1404.3.2 on the exterior side of the frame wall.

Reason:

Class III vapor retarders should be permitted for use in Climate Zones 1 through 3. Currently, the code is unclear or implies they may not be permitted. In these warmer climates, the conditions of Table 1404.3.2 are not necessary. Therefore, the inclusion of Climate Zones 1-3 is provided in the text of Section 1404.3.2. This change will also make it clear that it is OK to use latex paints (many of which could be classified as a Class III vapor retarder) as interior finishes in these climate zones, even if not declared to be a vapor retarder.

Cost Impact

The code change proposal will not increase or decrease the cost of construction .

This is a clarification of the code with no cost impact.

Internal ID: 2342

FS124-18

IBC: 1404.3.2

Proponent: Kingston Chow, APA - The Engineered Wood Association, representing APA - The Engineered Wood Association (kingston.chow@apawood.org); Borjen Yeh, APA - The Engineered Wood Association, representing APA - The Engineered Wood Association (borjen.yeh@apawood.org)

2018 International Building Code

1404.3.2 Class III vapor retarders. Class III vapor retarders shall be permitted where any one of the conditions in Table 1404.3.2 is met. Only Class III vapor retarders shall be used on the interior side of frame walls where ~~foam plastic insulating sheathing~~ continuous insulation with a perm rating of less than 1 is applied in accordance with Table 1404.3.2 on the exterior side of the frame wall.

Reason:

This proposed change ensures language is consistent with Table 1404.3.2 (i.e., continuous insulation) and applies to other types of continuous insulation with a perm rating of less than 1 other than foam plastic insulating sheathing.

The reason the IBC requires an interior Class III vapor retarder in conjunction with low perm exterior foam plastic sheathing is to ensure at least one path for walls to dry when they get wet. While exterior continuous insulation helps to minimize one source of moisture accumulation in wall assemblies (condensation), wetting due to improper flashing and detailing, leaky windows, wind driven rain, etc. necessitates that drying of wall assemblies can take place. Therefore, the current requirement for ensuring drying to the interior should apply to any exterior continuous insulation with a perm rating less than 1.

Cost Impact

The code change proposal will not increase or decrease the cost of construction .

This change proposal simply clarifies the terminology used in the provision.

Internal ID: 1693

FS125-18

IBC: TABLE 1404.3.2, 1404.3.2

Proponent: Jay Crandell, P.E., ARES Consulting, representing Foam Sheathing Committee of the American Chemistry Council

2018 International Building Code

Revise as follows:

**TABLE 1404.3.2
CLASS III VAPOR RETARDERS**

ZONE	CLASS III VAPOR RETARDERS PERMITTED FOR:^a
Marine-4	Vented cladding over wood structural panels Vented cladding over fiberboard Vented cladding over gypsum Continuous insulation with R -value $\geq R2.5$ over 2 \times 4 wall Continuous insulation with R -value $\geq R3.75$ over 2 \times 6 wall
5	Vented cladding over wood structural panels Vented cladding over fiberboard Vented cladding over gypsum Continuous insulation with R -value $\geq R5$ over 2 \times 4 wall Continuous insulation with R -value $\geq R7.5$ over 2 \times 6 wall
6	Vented cladding over fiberboard Vented cladding over gypsum Continuous insulation with R -value $\geq R7.5$ over 2 \times 4 wall Continuous insulation with R - value $\geq R11.25$ over 2 \times 6 wall
7 and 8	Continuous insulation with R -value $\geq R10$ over 2 \times 4 wall Continuous insulation with R -value $\geq R15$ over 2 \times 6 wall

For SI: 1 pound per cubic foot = 16 kg/m³.

- a. Spray foam with a maximum permanence of 1.5 perms at the installed thickness applied to the interior cavity side of wood structural panels, fiberboard, insulating sheathing or gypsum is deemed to meet the continuous insulation requirement where the spray foam R-value meets or exceeds the specified insulating sheathing R-value.

1404.3.2 Class III vapor retarders. Class III vapor retarders shall be permitted in Climate Zones 1 through 3 and where any one of the conditions in Table 1404.3.2 is met. Only Class III vapor retarders shall be used on the interior side of frame walls where foam plastic insulating sheathing with a perm rating of less than 1 is applied in accordance with Table 1404.3.2 on the exterior side of the frame wall.

Reason:

Section 1404.3.2 is revised to recognize that Class III vapor retarders also are permitted in Climate Zones 1-3 without having to comply with the conditions in Table 1404.3.2 intended for colder climate applications. This clarifies the code as intended and resolves an interpretation problem where it is unclear that Class III vapor retarders are OK to use in Climate Zones 1-3. In fact, latex paint often complies with a Class III vapor retarder and is commonly used in all climate zones for interior finish, even if not declared to be a Class III vapor retarder.

Table 1404.3.2 is revised so that the requirements for Climate Zone "Marine 4" are applied to all of Climate Zone 4. The Marine 4 climate zone is actually a warmer-in-winter climate zone than the remainder of Climate Zone 4. Thus, if conditions are necessary to control water vapor in Marine 4 it should also be required in all of Climate Zone 4 and especially in the "moist" (A) regions of Climate Zone 4. This need has been confirmed by experience, field data, testing and analysis in recent years. Refer to the bibliography for additional information and substantiation.

Bibliography:

Assessment of Hygrothermal Performance and Design Guidance for Modern Light-Frame Wall Assemblies, ASTM STP1599, J. H. Crandell, 2017, pp.362-394, https://www.astm.org/DIGITAL_LIBRARY/STP/PAGES/STP159920160097.htm

Assessment of Water Vapor Control Methods for Modern Insulated Light-Frame Wall Assemblies, ABTG Research Report No. 1410-03, Applied Building Technology Group LLC, 2015, <https://www.appliedbuildingtech.com/rr/1410-03>

Cost Impact

The code change proposal will increase the cost of construction .

While this proposal will potentially increase cost of using a Class III vapor retarder in much of Climate Zone 4 (not Marine 4), one interpretation is that this proposal actually adds the option of using a Class III vapor retarder in all of Climate Zone 4 and also in Climate Zones 1-3. In the latter case, the proposal may actually reduce costs by allowing interior latex paint to be used as the vapor retarder. From a moisture durability and risk standpoint, this proposal also should reduce associated costs after construction.

Internal ID: 1009

FS126-18

IBC: TABLE 1404.3.2

Proponent: Craig Conner, representing self (craig.conner@mac.com); Joseph Lstiburek, representing Self (joe@buildingsscience.com)

2018 International Building Code

Revise as follows:

**TABLE 1404.3.2
CLASS III VAPOR RETARDERS**

ZONE	CLASS III VAPOR RETARDERS PERMITTED FOR:^a
Marine- 4	Vented cladding over wood structural panels Vented cladding over fiberboard Vented cladding over gypsum Continuous insulation with R -value $\geq R2.5$ over 2×4 wall Continuous insulation with R -value $\geq R3.75$ over 2×6 wall
5	Vented cladding over wood structural panels Vented cladding over fiberboard Vented cladding over gypsum Continuous insulation with R -value $\geq R5$ over 2×4 wall Continuous insulation with R -value $\geq R7.5$ over 2×6 wall
6	Vented cladding over fiberboard Vented cladding over gypsum Continuous insulation with R -value $\geq R7.5$ over 2×4 wall Continuous insulation with R -value $\geq R11.25$ over 2×6 wall
7 and 8	Continuous insulation with R -value $\geq R10$ over 2×4 wall Continuous insulation with R -value $\geq R15$ over 2×6 wall

For SI: 1 pound per cubic foot = 16 kg/m³.

- a. Spray foam with a maximum permanence of 1.5 perms at the installed thickness applied to the interior cavity side of wood structural panels, fiberboard, insulating sheathing or gypsum is deemed to meet the continuous insulation requirement where the spray foam *R*-value meets or exceeds the specified insulating sheathing *R*-value.

Reason:

When Table 1405.3.2 was first added to the IBC (and IRC Table R702.7), only Climate Zone 4 Marine was addressed and not all of Climate Zone 4. Subsequent experience, field data, testing and analysis has demonstrated that these requirements should apply to all of Climate Zone 4, not just Climate Zone 4 Marine.

Cost Impact

The code change proposal will decrease the cost of construction .

This gives another option to zones 4A and 4B. Sometimes the option will be less expensive.

Internal ID: 1984

FS127-18

IBC: TABLE 1404.3.2

Proponent: Jay Crandell, P.E., ARES Consulting, representing Foam Sheathing Committee of the American Chemistry Council

2018 International Building Code

Revise as follows:

**TABLE 1404.3.2
CLASS III VAPOR RETARDERS**

ZONE	CLASS III VAPOR RETARDERS PERMITTED FOR:^a
Marine 4	Vented cladding over wood structural panels Vented cladding over fiberboard Vented cladding over gypsum Continuous insulation with R-value \geq R2.5 over 2 x 4 wall Continuous insulation with R-value \geq R3.75 over 2 x 6 wall
5	Vented cladding over wood structural panels Vented cladding over fiberboard Vented cladding over gypsum Continuous insulation with R-value \geq R5 over 2 x 4 wall Continuous insulation with R-value \geq R7.5 over 2 x 6 wall
6	Vented cladding over fiberboard Vented cladding over gypsum Continuous insulation with R-value \geq R7.5 over 2 x 4 wall Continuous insulation with R-value \geq R11.25 over 2 x 6 wall
7 and 8	Continuous insulation with R-value \geq R10 over 2 x 4 wall Continuous insulation with R-value \geq R15 over 2 x 6 wall
8	<u>Continuous insulation with R-value \geq 12.5 over 2x4 wall.</u> <u>Continuous insulation with R-value \geq 20 over 2x6 wall</u>

For SI: 1 pound per cubic foot = 16 kg/m³.

- a. Spray foam with a maximum permanence of 1.5 perms at the installed thickness applied to the interior cavity side of wood structural panels, fiberboard, insulating sheathing or gypsum is deemed to meet the continuous insulation requirement where the spray foam *R*-value meets or exceeds the specified insulating sheathing *R*-value.

Reason:

This proposal corrects an inadvertent error when Table 1404.3.2 was first included in the code. Climate Zone 8 was not intended to be included with Climate Zone 7. Climate Zone 8 is a colder climate and requires additional continuous insulation to maintain proper moisture control and equivalent performance. The proposed *R*-values for Climate Zone 8 are consistent with the experience and technical basis for provisions in the other climate zones addressed in Table 1404.3.2. Refer to the bibliography for additional information and substantiation.

Bibliography:

Assessment of Hygrothermal Performance and Design Guidance for Modern Light-Frame Wall Assemblies, ASTM STP1599, J. H. Crandell, 2017, pp.362-394, https://www.astm.org/DIGITAL_LIBRARY/STP/PAGES/STP159920160097.htm

Assessment of Water Vapor Control Methods for Modern Insulated Light-Frame Wall Assemblies, ABTG Research Report No. 1410-03, Applied Building Technology Group LLC, 2015, <https://www.appliedbuildingtech.com/rr/1410-03>

Cost Impact

The code change proposal will increase the cost of construction .

This proposed technical correction of the code will increase the cost of construction only where using a Class III vapor retarder (e.g. latex paint) in Climate Zone 8. However, other vapor retarder options and wall assembly options are unchanged so, technically, this should not increase the cost of construction where these other options are used.

Internal ID: 999

FS128-18

IBC: TABLE 1404.3.2

Proponent: Craig Conner, representing self (craig.conner@mac.com); Joseph Lstiburek, representing Self (joe@buildingsscience.com)

2018 International Building Code

Revise as follows:

**TABLE 1404.3.2
CLASS III VAPOR RETARDERS**

ZONE	CLASS III VAPOR RETARDERS PERMITTED FOR:^a
Marine 4	Vented cladding over wood structural panels Vented cladding over fiberboard Vented cladding over gypsum Continuous insulation with R-value \geq R2.5 over 2 x 4 wall Continuous insulation with R-value \geq R3.75 over 2 x 6 wall
5	Vented cladding over wood structural panels Vented cladding over fiberboard Vented cladding over gypsum Continuous insulation with R-value \geq R5 over 2 x 4 wall Continuous insulation with R-value \geq R7.5 over 2 x 6 wall
6	Vented cladding over fiberboard Vented cladding over gypsum Continuous insulation with R-value \geq R7.5 over 2 x 4 wall Continuous insulation with R-value \geq R11.25 over 2 x 6 wall
7 and 8	Continuous insulation with R-value \geq R10 over 2 x 4 wall Continuous insulation with R-value \geq R15 over 2 x 6 wall
8	<u>Continuous insulation with R-value \geq R12.5 over 2 x 4 wall</u> <u>Continuous insulation with R-value \geq R20 over 2 x 6 wall</u>

For SI: 1 pound per cubic foot = 16 kg/m³.

- a. Spray foam with a maximum permanence of 1.5 perms at the installed thickness applied to the interior cavity side of wood structural panels, fiberboard, insulating sheathing or gypsum is deemed to meet the continuous insulation requirement where the spray foam *R*-value meets or exceeds the specified insulating sheathing *R*-value.

Reason:

When Table 1404.3.2 was first added to the IBC (and IRC Table R702.7) Climate Zone 8 was inadvertently included with Climate Zone 7. This corrects that error. The technical justification for this can be found at the following link (specifically Table 2):

<https://buildingscience.com/documents/building-science-insights/bsi-100-hybrid-assemblies> as available January 10th, 2018

Cost Impact

The code change proposal will increase the cost of construction .

This change increases the insulation level, which in principal would cost more. However, the table has the incorrect value.

Internal ID: 1972

FS129-18

IBC: TABLE 1404.3.2

Proponent: Mike Fischer, Kellen Company, representing The Center for the Polyurethanes Industry of the American Chemistry Council (mfischer@kellencompany.com)

2018 International Building Code

Revise as follows:

**TABLE 1404.3.2
CLASS III VAPOR RETARDERS**

ZONE	CLASS III VAPOR RETARDERS PERMITTED FOR:^a
Marine 4	Vented cladding over wood structural panels Vented cladding over fiberboard Vented cladding over gypsum Continuous insulation with <i>R</i> -value \geq R2.5 over 2 × 4 wall Continuous insulation with <i>R</i> -value \geq R3.75 over 2 × 6 wall
5	Vented cladding over wood structural panels Vented cladding over fiberboard Vented cladding over gypsum Continuous insulation with <i>R</i> -value \geq R5 over 2 × 4 wall Continuous insulation with <i>R</i> -value \geq R7.5 over 2 × 6 wall
6	Vented cladding over fiberboard Vented cladding over gypsum Continuous insulation with <i>R</i> -value \geq R7.5 over 2 × 4 wall Continuous insulation with <i>R</i> -value \geq R11.25 over 2 × 6 wall
7 and 8	Continuous insulation with <i>R</i> -value \geq R10 over 2 × 4 wall Continuous insulation with <i>R</i> -value \geq R15 over 2 × 6 wall

For SI: 1 pound per cubic foot = 16 kg/m³.

- a. Compliance with the R-value requirement may be met by continuous insulation, spray foam, or a combination of continuous insulation and spray foam. Spray foam with shall have a maximum permeance of 1.5 perms at the installed thickness and shall be applied to the interior cavity side of wood structural panels, fiberboard, insulating sheathing or gypsum is deemed to meet the continuous insulation requirement where the spray foam R value meets or exceeds the specified insulating sheathing R value-gypsum.
- b. For the purposes of compliance with Table 1404.3.2, the combined R-values of spray foam plastic insulation and continuous insulation shall be permitted to be counted towards the continuous R-value requirement.

Reason:

The current Table 1404.3.2 mandates continuous insulation for moisture control but provides an exception for spray foam in the cavity. The table does not currently permit a combination of continuous and cavity; this is inconsistent with the intent of the cavity option. Additionally, with prescriptive options in the IECC including hybrid insulation systems with a combination of cavity and continuous, this will help correlate the IBC and IECC requirements. The proposal simply modifies the table so that the total R-Value can be achieved by continuous, cavity, or a combination of insulation strategies.

Cost Impact

The code change proposal will decrease the cost of construction .

The proposal increases options for insulation used as condensation control by adding an option for a hybrid system. It adds no mandatory requirements.

Internal ID: 2382

FS130-18

IBC: TABLE 1404.3.2

Proponent: Mike Fischer, Kellen Company, representing The Center for the Polyurethanes Industry of the American Chemistry Council (mfischer@kellencompany.com)

2018 International Building Code

Revise as follows:

**TABLE 1404.3.2
CLASS III VAPOR RETARDERS**

ZONE	CLASS III VAPOR RETARDERS PERMITTED FOR:^{a,b}
Marine 4	Vented cladding over wood structural panels Vented cladding over fiberboard Vented cladding over gypsum Continuous insulation with <i>R</i> -value \geq R2.5 over 2 x 4 wall Continuous insulation with <i>R</i> -value \geq R3.75 over 2 x 6 wall
5	Vented cladding over wood structural panels Vented cladding over fiberboard Vented cladding over gypsum Continuous insulation with <i>R</i> -value \geq R5 over 2 x 4 wall Continuous insulation with <i>R</i> -value \geq R7.5 over 2 x 6 wall
6	Vented cladding over fiberboard Vented cladding over gypsum Continuous insulation with <i>R</i> -value \geq R7.5 over 2 x 4 wall Continuous insulation with <i>R</i> -value \geq R11.25 over 2 x 6 wall
7 and 8	Continuous insulation with <i>R</i> -value \geq R10 over 2 x 4 wall Continuous insulation with <i>R</i> -value \geq R15 over 2 x 6 wall

For SI: 1 pound per cubic foot = 16 kg/m³.

a. Spray foam with a maximum permeance of 1.5 perms at the installed thickness applied to the interior cavity side of wood structural panels, fiberboard, insulating sheathing or gypsum is deemed to meet the continuous insulation moisture control requirement where the spray foam R-value meets or exceeds the specified insulating sheathing R-value.

b. The requirements in this table apply only to insulation used to control moisture in order to permit the use of Class III vapor retarders. The insulation materials used to satisfy this option also contribute to but do not supersede the thermal envelope requirements of the International Energy Conservation Code.

Reason:

The proposal clarifies that spray foam used to satisfy the continuous insulation requirements are intended to be used for moisture control. It adds an additional footnote to the table to clarify that the provisions of the IECC are not supplanted by this option.

Cost Impact

The code change proposal will not increase or decrease the cost of construction .

The proposal is editorial.

Internal ID: 1951

FS131-18

IBC: 1404.3.3

Proponent: John Woestman, Kellen Co., representing Extruded Polystyrene Foam Association (XPSA)
(jwoestman@kellencompany.com)

2018 International Building Code

Revise as follows:

1404.3.3 Material vapor retarder class. The *vapor retarder class* shall be based on the manufacturer's certified testing or a tested assembly.

The following shall be deemed to meet the class specified:

Class I: Sheet polyethylene, nonperforated aluminum foil with a perm rating of less than or equal to 0.1.

Class II: Kraft-faced fiberglass batts or vapor retarder paint applied in accordance with the manufacturer's instructions for a perm rating greater than 0.1 and less than or equal to 1.0.

Class III: Latex or enamel paint applied in accordance with the manufacturer's instructions for a perm rating of greater than 1.0 and less than or equal to 10.0.

Reason:

This proposal clarifies that where paints are used as vapor retarders they must be applied in accordance with the manufacturer's instructions to achieve the required perm rating for the vapor retarder class. Misuse or misapplication of paints that also may not be specifically recommended for use as vapor retarders has been shown to increase the risk of moisture problems in walls with Class III vapor retarders. Cases have been documented where paint applications have a water vapor permeance of more than three times greater than the maximum limit for Class III vapor retarders. As a result, walls intended to rely on Class III vapor retarders can experience an increased risk of moisture accumulation problems. This proposal will provide the ability to avoid this problem.

Cost Impact

The code change proposal will not increase or decrease the cost of construction .

This proposal clarifies the intent of the code and does not impact cost.

Internal ID: 1012

FS132-18

IBC: 1404.3.4

Proponent: Charles Clark Jr, Brick Industry Association, representing Brick Industry Association, representing the Masonry Alliance for Codes and Standards (cclark@bia.org)

2018 International Building Code

Revise as follows:

1404.3.4 Minimum ~~clear~~ airspaces and vented openings for vented cladding. For the purposes of this section, vented cladding shall include the following minimum clear airspaces:

1. Vinyl, polypropylene or horizontal aluminum siding applied over a weather-resistive barrier as specified in this chapter.
2. Brick veneer with ~~a clear~~ an airspace as specified in this code.
3. Other *approved* vented claddings.

Reason:

Although the use of the term "clear" in this text appears intended to refer to an airspace sufficiently unrestricted to permit air and water movement, this same term has been interpreted, in many cases, to mean that the presence of any mortar whatsoever within the airspace of a brick veneer cladding results in a non-code compliant condition for the entire brick veneer. Mortar fins and mortar droppings are an inherent part of masonry construction. It has been demonstrated that no matter how experienced the mason or how carefully the masonry is constructed, the brick veneer airspace will never be completely devoid of mortar.

However, empirical evidence has overwhelmingly confirmed that acceptable drainage performance exists even when the airspace contains mortar fins and mortar droppings. Removing the term "clear" from the IBC text allows respective material codes and standards to define the airspace condition in a manner appropriate to the cladding material.

Cost Impact

The code change proposal will not increase or decrease the cost of construction .

This proposed code change serves to clarify existing language and will not change the cost of construction, as it allows existing construction methods to be maintained.

Internal ID: 1598

FS133-18

IBC: 1404.4

Proponent: Mike Fischer, Kellen Company, representing The Polyisocyanurate Insulation Manufacturers Association (mfischer@kellencompany.com)

2018 International Building Code

Revise as follows:

1404.4 Flashing. Flashing shall be installed in such a manner so as to prevent moisture from entering the wall or to redirect that moisture to the ~~exterior surface of the exterior wall finish or to a water-resistive barrier complying with Section 1403.2 and that is part of a means of drainage complying with Section 1402.2.~~ Flashing shall be installed at the perimeters of exterior door and window assemblies, penetrations and terminations of *exterior wall* assemblies, *exterior wall* intersections with roofs, chimneys, porches, decks, balconies and similar projections and at built-in gutters and similar locations where moisture could enter the wall. Flashing with projecting flanges shall be installed on both sides and the ends of copings, under sills and continuously above projecting *trim*. Where self-adhered membranes are used as flashings of *fenestration* in wall assemblies, those self-adhered flashings shall comply with AAMA 711. Where fluid applied membranes are used as flashing for *exterior wall* openings, those fluid applied membrane flashings shall comply with AAMA 714.

Reason:

This proposal provides language to coordinate with similar language in the 2018 IRC Section R703.4 which appropriately recognizes that some flashing applications necessarily direct water to the water-resistive barrier surface where it is subsequently drained at flashing or weeps extending through the exterior wall covering.

Cost Impact

The code change proposal will not increase or decrease the cost of construction .

This proposal is a clarification of the code and has no cost impact.

Internal ID: 992

FS134-18

IBC: 1405.1.1

Proponent: Ronald Nickson, Nickson Code Consulting, representing Rockwool (nicksoncodeconsulting@gmail.com)

2018 International Building Code

Revise as follows:

1405.1.1 Types I, II, III, IV and ~~IV~~V construction. On buildings of Types I, II, III, IV and ~~IV~~V construction, *exterior wall coverings* shall be permitted to be constructed of combustible materials, complying with the following limitations:

1. Combustible *exterior wall coverings* shall not exceed 10 percent of an *exterior wall* surface area where the fire separation distance is 5 feet (1524 mm) or less.
2. Combustible *exterior wall coverings* shall be limited to 40 feet (12 192 mm) in height above grade plane.
3. Combustible *exterior wall coverings* constructed of fire-retardant-treated wood complying with Section 2303.2 for exterior installation shall not be limited in wall surface area where the fire separation distance is 5 feet (1524 mm) or less and shall be permitted up to 60 feet (18 288 mm) in height above grade plane regardless of the fire separation distance.
4. Wood veneers shall comply with Section 1404.5.

Exception: Combustible exterior wall covering in Type V construction is not limited to 10 percent of the exterior wall surface.

Reason:

This proposal adds Type V construction to Section 1405 Combustible Materials on The Exterior Side of Exterior Walls, to be included for what is already required for Types I, II, III and IV construction. This is a companion change to a proposed new Section 1406.2 proposing to incorporate into the code fire test procedures to determine the impact different materials will have on the spread of a fire on the exterior wall and spreading into the attic. This change addresses ignitability based on the distance from the property line. Proposal 1402.6 address the methodology to determine if the fire will reach the attic.

Energy code requirements have prompted the construction industry to include combustible exterior continuous insulation that can be easily ignited by reflection from glazing or fires in adjacent buildings. Fire separation distance requirements are predicated on historical construction materials and have been deemed to provide a sufficient distance from property lines based on the radiation thresholds provided in Table 1405.1.1.1.2. Type V buildings have not needed exterior wall fire related restrictions because product combinations such as vinyl siding over OSB have been sufficiently fire-safe. The introduction of combustible materials over the OSB board as a result of energy code requirements without any fire testing requirements presents a high risk for ignition when exposed to fires from neighbouring buildings or other burning objects.

A report from NFPA Research entitled, Residential Structure Fires Originating On Outer Walls. Spreading On Exterior Walls or Trim, and Beginning On An Outer Wall with Plastic, January 2018, identifies the problem that now exists because of the increase use of unprotected combustible products used to meet the current energy code requirements. The report documents the number of residential fires where the item contributing most to flame spread was exterior sidewall covering and surface finish. This type of fire has increased dramatically in recent years causing an annual average of 50 casualties, 345 injuries and \$539 million in property damage.

Cost Impact

The code change proposal will not increase or decrease the cost of construction .

The cost impact if any is minor. Some cost will be incurred by material manufacturers to determine compliance. Material and installation cost are basically natural.

Internal ID: 1791

FS135-18

IBC: 1405.1.1

Proponent: William Hall, Portland Cement Association, representing Alliance For Concrete Codes and Standards (jhall@cement.org); Jason Thompson, National Concrete Masonry Association, representing Masonry Alliance for Codes and Standards (jthompson@ncma.org)

2018 International Building Code

Revise as follows:

1405.1.1 Types I, II, III and IV construction. On buildings of Types I, II, III and IV construction, *exterior wall coverings* shall be permitted to be constructed of combustible materials, complying with the following limitations:

1. Combustible *exterior wall coverings* shall not exceed 10 percent of an *exterior wall* surface area where the fire separation distance is 5 feet (1524 mm) or less.
2. Combustible *exterior wall coverings* shall be limited to 40 feet (12 192 mm) in height above grade plane.
3. Combustible *exterior wall coverings* constructed of fire-retardant-treated wood complying with Section 2303.2 for exterior installation shall not be limited in wall surface area where the fire separation distance is 5 feet (1524 mm) or less and shall be permitted up to 60 feet (18 288 mm) in height above grade plane regardless of the fire separation distance. Fire-retardant-treated-wood exterior wall coverings over 40 ft. shall also comply with Section 1402.5.
4. Wood veneers shall comply with Section 1404.5. Fire-retardant-treated-wood veneers over 40-feet shall also comply with Section 1402.5.

Reason:

Fire-retardant-treated wood (FRTW) exterior wall coverings and veneers are permitted to go to a height of 60 ft. on buildings of Type I, II, III and IV construction. However, FRTW is classified as a combustible material. Testing of these combustible exterior wall materials to NFPA 285 on buildings of Type I, II, III and IV construction is required in applications over 40ft unless it meets Exception #2 of 1402.5. This proposal helps to clarify this testing requirement for FRTW.

Cost Impact

The code change proposal will not increase or decrease the cost of construction.

This proposal is clarification for what is currently required in the code.

Internal ID: 1522

FS136-18

IBC: 202, 1406.2, 1408.2, 2602.1

Proponent: Michael O'Brian, Chair, representing FCAC (FCAC@iccsafe.org)

2018 International Building Code

Revise as follows:

SECTION 202 DEFINITIONS

[BF] EXTERIOR WALL ENVELOPE. A system or assembly of exterior wall components, including exterior wall ~~finish covering~~ materials, that provides protection of the building structural members, including framing and sheathing materials, and conditioned interior space, from the detrimental effects of the exterior environment.

1406.2 Exterior wall ~~finish covering~~. MCM used as *exterior wall ~~finish covering~~* or as elements of balconies and similar projections and bay and oriel windows to provide cladding or weather resistance shall comply with Sections 1406.4 through 1406.14.

1408.2 Exterior wall ~~finish covering~~. HPL used as *exterior wall covering* or as elements of balconies and similar projections and bay and oriel windows to provide cladding or weather resistance shall comply with Sections 1408.4 through 1408.14.

2602.1 Exterior ~~finish wall covering~~ and ~~architectural trim~~. See Chapter 14 for requirements for *exterior wall ~~finish covering~~ and ~~architectural trim~~*.

Reason:

This code change proposal is basically editorial and clarification. The term exterior wall covering is defined in the code, but the term exterior wall finish is not defined. The exterior wall envelope contains exterior wall covering materials and other materials.

Chapter 14, in section 1405, deals with the requirements for combustible exterior wall coverings but there is no section dealing specifically with requirements for exterior wall finish. This may lead to concern that references to exterior wall finish refer to items that are different from those that are regulated by section 1405. The change in terminology may make it clear what is being referenced.

It is the intent of this proposal for "exterior wall covering" to be reflected as a defined term in the definition of Exterior Wall Envelope and sections 1406.2; 1408.2 and 3602.1

The only other place in ICC codes where the term exterior wall finish is used is in the residential code and that will not be addressed in group A.

The additional change in 2602.1 refers to the fact that the requirements in chapter 14 (in sections 1401.1, 1406.3, 1406.10.3, 1408.3 and 1408.10.3) all refer to architectural trim.

Note: This is the current IBC definition for **TRIM:** Picture molds, chair rails, baseboards, handrails, door and window frames and similar decorative or protective materials used in fixed applications.

This proposal is submitted by the ICC Fire Code Action Committee (FCAC). The FCAC was established by the ICC Board of Directors to pursue opportunities to improve and enhance assigned International Codes with regard to fire safety and hazardous materials in new and existing buildings and facilities and the protection of life and property in wildland urban interface areas. In 2017 the Fire-CAC has held 3 open meetings. In addition, there were numerous conference calls, Regional Work Group and Task Group meetings for the current code development cycle, which included members of the committees as well as any interested parties, to discuss and debate the proposed changes. Related documentation and reports are posted on the FCAC website at: <https://www.iccsafe.org/codes-tech-support/cs/fire-code-action-committee-fcac/>

This proposal is one in a series of related proposals intended to address different technical changes to Chapter 14. While the Fire Code Committee will consider each proposal independently, the intent is for approval of all proposals in this package which have been submitted as a correlated set of companion code change proposals.

The FCAC analyzed several fatal fires related to exterior façade/curtain wall fires in the development of these new code requirements. The intent of these proposals is to provide a reasonable set of code requirements to ensure fire safety and weather protection for buildings that utilize combustible materials and/or assemblies for the building exterior wall envelope.

1. Grenfell fire, London England:

Buildings Across U.S. Are Wrapped in Same Panels That Fueled Deadly London Fire: <https://www.wsj.com/articles/built-to-burn-thousands-of-buildings-world-wide-are-wrapped-in-combustible-panels-1508858048>

Why Grenfell Tower Burned: Regulators Put Cost Before Safety
<https://www.nytimes.com/2017/06/24/world/europe/grenfell-tower-london-fire.html>

2. Torch Tower Fire, Dubai

https://en.wikipedia.org/wiki/The_Marina_Torch January 8th, 2018

3. Address Hotel Fire, Dubai https://en.wikipedia.org/wiki/The_Address_Downtown_Dubai January 8th, 2018

Cost Impact

The code change proposal will not increase or decrease the cost of construction .

This proposal is simply editorial and clarification.

Internal ID: 391

FS137-18

IBC: 1406.8

Proponent: Michael O'Brian, Chair, representing FCAC (FCAC@iccsafe.org)

2018 International Building Code

Revise as follows:

1406.8 Fire-resistance rating. Where MCM systems are used on *exterior walls* required to have a *fire-resistance rating* in accordance with Section 705, evidence shall be submitted to the *building official* that the required *fire-resistance rating* is maintained.

Exception: MCM systems which are part of an exterior wall envelope not containing foam plastic insulation, ~~which and~~ are installed on the outer surface of a fire-resistance-rated *exterior wall* in a manner such that the attachments do not penetrate through the entire *exterior wall* assembly, shall not be required to comply with this section.

Reason:

The definition of metal composite material (MCM), shown below, does not allow MCMs to contain foam plastic insulation. The definition of metal composite material (MCM) system, also shown below, indicates that this is an exterior wall covering.

Therefore, this section needs clarification because the foam plastic insulation cannot be contained within the MCM system, but foam plastic can be part of the same exterior wall envelope that also includes the MCM system and only if the entire exterior wall envelope does not contain foam plastic insulation is this exception valid.

METAL COMPOSITE MATERIAL (MCM). A factory manufactured panel consisting of metal skins bonded to both faces of a solid plastic core.

METAL COMPOSITE MATERIAL (MCM) SYSTEM. An exterior wall covering fabricated using MCM in a specific assembly including joints, seams, attachments, substrate, framing and other details as appropriate to a particular design.

EXTERIOR WALL ENVELOPE. A system or assembly of exterior wall components, including exterior wall finish materials, that provides protection of the building structural members, including framing and sheathing materials, and conditioned interior space, from the detrimental effects of the exterior environment.

This proposal is submitted by the ICC Fire Code Action Committee (FCAC). The FCAC was established by the ICC Board of Directors to pursue opportunities to improve and enhance assigned International Codes with regard to fire safety and hazardous materials in new and existing buildings and facilities and the protection of life and property in wildland urban interface areas. In 2017 the Fire-CAC has held 3 open meetings. In addition, there were numerous conference calls, Regional Work Group and Task Group meetings for the current code development cycle, which included members of the committees as well as any interested parties, to discuss and debate the proposed changes. Related documentation and reports are posted on the FCAC website at: <https://www.iccsafe.org/codes-tech-support/cs/fire-code-action-committee-fcac/>

This proposal is one in a series of related proposals intended to address different technical changes to Chapter 14. While the Fire Code Committee will consider each proposal independently, the intent is for approval of all proposals in this package which have been submitted as a correlated set of companion code change proposals.

The FCAC analyzed several fatal fires related to exterior façade/curtain wall fires in the development of these new code requirements. The intent of these proposals is to provide a reasonable set of code requirements to ensure fire safety and weather protection for buildings that utilize combustible materials and/or assemblies for the building exterior wall envelope.

1. Grenfell fire, London England:

Buildings Across U.S. Are Wrapped in Same Panels That Fueled Deadly London Fire: <https://www.wsj.com/articles/built-to-burn-thousands-of-buildings-world-wide-are-wrapped-in-combustible-panels-1508858048>

Why	Grenfell	Tower	Burned:	Regulators	Put	Cost	Before	Safety

<https://www.nytimes.com/2017/06/24/world/europe/grenfell-tower-london-fire.html>

2. Torch Tower Fire, Dubai

https://en.wikipedia.org/wiki/The_Marina_Torch January 8th, 2018

3. Address Hotel Fire, Dubai https://en.wikipedia.org/wiki/The_Address_Downtown_Dubai January 8th, 2018

Cost Impact

The code change proposal will not increase or decrease the cost of construction .

This proposal is simply editorial and clarification.

Internal ID: 392

FS138-18

IBC: 1406.9, 1406.9.1 (New), 1406.9.2 (New)

Proponent: Michael O'Brian, Chair, representing FCAC (FCAC@iccsafe.org)

2018 International Building Code

Revise as follows:

~~1406.9 Surface burning characteristics. Fire testing.~~ Unless otherwise specified, MCM shall have a ~~flame spread index of 75 or less and a smoke developed index of 450 or less when tested in the maximum thickness intended for use in accordance with ASTM E84 or UL 723.~~ comply with Sections 1406.9.1 and 1406.9.2.

Add new text as follows:

1406.9.1 Surface burning characteristics. The MCM shall have a flame spread index of 75 or less and a smoke-developed index of 450 or less when tested in the maximum thickness intended for use in accordance with ASTM E84 or UL 723.

1406.9.2 Specifications. MCM shall be required to comply with the following:

1. MCM shall have a self-ignition temperature of 650°F (343°C) or greater where tested in accordance with ASTM D1929.
2. The MCM shall conform to a combustibility classification of CC1.

Class CC1: Plastic materials that have a burning extent of 1 inch (25 mm) or less where tested at a nominal thickness of 0.060 inch (1.5 mm), or in the thickness intended for use, in accordance with ASTM D635.

Reason:

When amendments were proposed to the requirements in the 2009 IBC for MCM (2012 code cycle) the supporting justification was based on existing allowances for light-transmitting plastics included in Chapter 26. Due to substantial losses throughout the world, it has become apparent that the correlation between MCM and Light-transmitting plastics was not a valid comparison as related to fire risk of these very different building materials.

It does not make sense then that MCMs only need to meet the flame spread and ignition test under certain circumstances. They need to meet it always and this proposal adds the requirements in the general section. The requirement for smoke based on either ASTM D2843 or ASTM E84 is not being added because they already need to meet the smoke requirement based on ASTM E84 anyway so duplicate testing would be unnecessary. Of the two requirements based on ASTM D635 (also known as UL 94 HB) used for light-transmitting plastics, the one associated with CC2 (which is much weaker) is not being proposed because it would not be meaningful for a material required to meet a Class B in ASTM E84.

This proposal is submitted by the ICC Fire Code Action Committee (FCAC). The FCAC was established by the ICC Board of Directors to pursue opportunities to improve and enhance assigned International Codes with regard to fire safety and hazardous materials in new and existing buildings and facilities and the protection of life and property in wildland urban interface areas. In 2017 the Fire-CAC has held 3 open meetings. In addition, there were numerous conference calls, Regional Work Group and Task Group meetings for the current code development cycle, which included members of the committees as well as any interested parties, to discuss and debate the proposed changes. Related documentation and reports are posted on the FCAC website at: <https://www.iccsafe.org/codes-tech-support/cs/fire-code-action-committee-fcac/>

This proposal is one in a series of related proposals intended to address different technical changes to Chapter 14. While the Fire Code Committee will consider each proposal independently, the intent is for approval of all proposals in this package which have been submitted as a correlated set of companion code change proposals.

The FCAC analyzed several fatal fires related to exterior façade/curtain wall fires in the development of these new code requirements. The intent of these proposals is to provide a reasonable set of code requirements to ensure fire safety and weather protection for buildings that utilize combustible materials and/or assemblies for the building exterior wall envelope.

1. Grenfell fire, London England:

Buildings Across U.S. Are Wrapped in Same Panels That Fueled Deadly London Fire: <https://www.wsj.com/articles/built-to-burn-thousands-of-buildings-world-wide-are-wrapped-in-combustible-panels-1508858048>

Why Grenfell Tower Burned: Regulators Put Cost Before Safety

<https://www.nytimes.com/2017/06/24/world/europe/grenfell-tower-london-fire.html>

2. Torch Tower Fire, Dubai

https://en.wikipedia.org/wiki/The_Marina_Torch January 8th, 2018

3. Address Hotel Fire, Dubai https://en.wikipedia.org/wiki/The_Address_Downtown_Dubai January 8th, 2018

Cost Impact

The code change proposal will increase the cost of construction .

The additional performance and test requirements will add minimal cost to construction for initial testing of an MCM panel.

Internal ID: 393

FS139-18

IBC: 1406.10, 1406.11, 1406.11.1, 1406.11.1.1, 1406.11.1.2, 1406.11.2, 1406.11.2.1, 1406.11.2.2, 1406.11.3, 1406.11.3.1, 1406.11.3.2, 1406.11.3.3, 1406.11.3.4, Delete in entirety,, 1406.11.3.5, 1406.11.4, 1406.11.4.1, 1406.11.4.2, 1406.11.4.3, 1406.11.4.4

Proponent: Andy Williams, Metal Construction Association, representing Metal Construction Association (afwilliams@Connect2amc.com)

2018 International Building Code

Revise as follows:

1406.10 Type I, II, III and IV construction. Where installed on buildings of Type I, II, III and IV construction, MCMs and MCM systems shall comply with Sections 1406.10.1 through 1406.10.4, or Section 1406.11.1406.10.3, for installations up to 40 feet (12 192 mm) above grade plane. Where installed on buildings of Type I, II, III and IV construction, MCMs and MCM systems shall comply with Sections 1406.10.1 through 1406.10.4, for installations greater than 40 feet (12 192 mm) above grade plane.

Delete without substitution:

~~1406.11 Alternate conditions.~~

~~MCM and MCM systems shall not be required to comply with Sections 1406.10.1 through 1406.10.4 provided that such systems comply with Section 1406.11.1, 1406.11.2, 1406.11.3 or 1406.11.4.~~

~~**1406.11.1 Installations up to 40 feet in height.** MCM shall not be installed more than 40 feet (12 190 mm) in height above grade where installed in accordance with Sections 1406.11.1.1 and 1406.11.1.2.~~

~~**1406.11.1.1 Fire separation distance of 5 feet or less.** Where the *fire separation distance* is 5 feet (1524 mm) or less, the area of MCM shall not exceed 10 percent of the *exterior wall surface*.~~

~~**1406.11.1.2 Fire separation distance greater than 5 feet.** Where the *fire separation distance* is greater than 5 feet (1524 mm), the area of *exterior wall surface coverage* using MCM shall not be limited.~~

~~**1406.11.2 Installations up to 50 feet in height.** MCM shall not be installed more than 50 feet (15 240 mm) in height above grade where installed in accordance with Sections 1406.11.2.1 and 1406.11.2.2.~~

~~**1406.11.2.1 Self-ignition temperature.** MCM shall have a self-ignition temperature of 650°F (343°C) or greater when tested in accordance with ASTM D1929.~~

~~**1406.11.2.2 Limitations.** Sections of MCM shall not exceed 300 square feet (27.9 m²) in area and shall be separated by not less than 4 feet (1219 mm) vertically.~~

~~**1406.11.3 Installations up to 75 feet in height (Option 1).** MCM shall not be installed more than 75 feet (22 860 mm) in height above grade plane where installed in accordance with Sections 1406.11.3.1 through 1406.11.3.5.~~

~~**Exception:** Buildings equipped throughout with an *automatic sprinkler system* in accordance with Section 903.3.1.1 shall be exempt from the height limitation.~~

~~**1406.11.3.1 Prohibited occupancies.** MCM shall not be permitted on buildings classified as Group A-1, A-2, H, I-2 or I-3 occupancies.~~

~~**1406.11.3.2 Nonfire-resistance-rated exterior walls.** MCM shall not be permitted on *exterior walls* required to have a *fire-resistance rating* by other provisions of this code.~~

~~1406.11.3.3 Specifications.~~

~~MCM shall be required to comply with all of the following:~~

- ~~1. MCM shall have a self-ignition temperature of 650°F (343°C) or greater when tested in accordance with ASTM D1929.~~
- ~~2. MCM shall conform to one of the following combustibility classifications when tested in accordance with ASTM D635:
Class CC1: Materials that have a burning extent of 1 inch (25 mm) or less when tested at a nominal thickness of 0.060 inch (1.5 mm) or in the thickness intended for use.~~

Class CC2: Materials that have a burning rate of $2\frac{1}{2}$ inches per minute (1.06 mm/s) or less when tested at a nominal thickness of 0.060 inch (1.5 mm) or in the thickness intended for use.

1406.11.3.4 Area limitation and separation. The maximum area of a single MCM panel and the minimum vertical and horizontal separation requirements for MCM panels shall be as provided for in Table 1406.11.3.4. The maximum percentage of *exterior wall* area of any story covered with MCM panels shall not exceed that indicated in Table 1406.11.3.4 or the percentage of unprotected openings permitted by Section 705.8, whichever is smaller.

Exception: In buildings provided with flame barriers complying with Section 705.8.5 and extending 30 inches (760 mm) beyond the *exterior wall* in the plane of the floor, a vertical separation shall not be required at the floor other than that provided by the vertical thickness of the flame barrier.

TABLE 1406.11.3.4
AREA LIMITATION AND SEPARATION REQUIREMENTS FOR MCM PANELS

For SI: 1 foot = 304.8 mm, 1 square foot = 0.0929 m².

a. For reductions in the minimum vertical separation, see Section 1406.11.3.4.

1406.11.3.5 Automatic sprinkler system increases. Where the building is equipped throughout with an *automatic sprinkler system* in accordance with Section 903.3.1.1, the maximum percentage area of *exterior wall* of any story covered with MCM panels and the maximum square footage of a single area of MCM panels in Table 1406.11.3.4 shall be increased 100 percent. The area of MCM panels shall not exceed 50 percent of the *exterior wall* area of any story or the area permitted by Section 705.8 for unprotected openings, whichever is smaller.

1406.11.4 Installations up to 75 feet in height (Option 2). MCM shall not be installed more than 75 feet (22 860 mm) in height above grade plane where installed in accordance with Sections 1406.11.4.1 through 1406.11.4.4.

Exception: Buildings equipped throughout with an *automatic sprinkler system* in accordance with Section 903.3.1.1 shall be exempt from the height limitation.

1406.11.4.1 Minimum fire separation distance. MCM shall not be installed on any wall with a fire separation distance less than 30 feet (9 144 mm).

Exception: Where the building is equipped throughout with an *automatic sprinkler system* in accordance with Section 903.3.1.1, the fire separation distance shall be permitted to be reduced to not less than 20 feet (6 096 mm).

1406.11.4.2 Specifications.

MCM shall be required to comply with all of the following:

Class CC2:

1. MCM shall have a self ignition temperature of 650°F (343°C) or greater when tested in accordance with ASTM D1929.
2. MCM shall conform to one of the following combustibility classifications when tested in accordance with ASTM D635:

Class CC1: Materials that have a burning extent of 1 inch (25 mm) or less when tested at a nominal thickness of 0.060 inch (1.5 mm), or in the thickness intended for use.

Materials that have a burning rate of 2³/₂ inches per minute (1.06 mm/s) or less when tested at a nominal thickness of 0.060 inch (1.5 mm), or in the thickness intended for use.

1406.11.4.3 Area and size limitations. The aggregate area of MCM panels shall not exceed 25 percent of the area of any *exterior wall face* of the story on which those panels are installed. The area of a single MCM panel installed above the first story above grade plane shall not exceed 16 square feet (1.5 m²) and the vertical dimension of a single MCM panel shall not exceed 4 feet (1219 mm).

Exception: Where the building is equipped throughout with an *automatic sprinkler system* in accordance with Section 903.3.1.1, the maximum aggregate area of MCM panels shall be increased to 50 percent of the *exterior wall face* of the story on which those panels are installed and there shall not be a limit on the maximum dimension or area of a single MCM panel.

1406.11.4.4 Vertical separations. Flame barriers complying with Section 705.8 and extending 30 inches (762 mm) beyond the *exterior wall* or a vertical separation of not less than 4 feet (1219 mm) in height shall be provided to separate MCM panels located on the *exterior walls* at one story intervals.

Exception: Buildings equipped throughout with an *automatic sprinkler system* in accordance with Section 903.3.1.1.

Reason:

Fire events around the world have made everyone rethink how MCM panels fit within the construction landscape. While many, if not all, of the fires have involved product and or wall assemblies that would not have been allowed under the IBC, it is clear that there are questions with the allowable use of standard core and fire resistive MCM panels. The MCM Manufacturers that are members of the Metal Construction Association agree that to simplify the application of MCM that Section 1406.11 Alternate conditions, which is based on the allowable use of other combustible exterior envelope material within the IBC, should be removed. This will help to remove questions from both designers and code compliance officials on the appropriate product to use.

The clarification of MCM and MCM systems is added because 1406.10.1 specifically applies to the MCM "panel" (referred to as MCM in the IBC). 1406.10.2 through 1406.10.4 references both MCM and MCM System.

By using the 40 feet above grade plane limit as a trigger for MCM System compliance with NFPA 285, the product decision is simplified and the IBC is made more clear.

The majority of the domestic MCM manufacturers are represented as members of the Metal Construction Association

(MCA)

Cost Impact

The code change proposal will not increase or decrease the cost of construction .

Over time, the material cost difference between standard and fire resistive core has narrowed significantly. The cost difference in the choice of material should be minimal and, in many cases there may be no negative cost impact.

Internal ID: 1273

FS140-18

IBC: 1406.11, 1406.11.1, 1406.11.2, 1406.11.2.1, 1406.11.2.2, 1406.11.3, 1406.11.3.1, 1406.11.3.2, 1406.11.3.3, 1406.11.3.4, TABLE 1406.11.3.4, 1406.11.3.5, 1406.11.4, 1406.11.4.1, 1406.11.4.2, 1406.11.4.3, 1406.11.4.4

Proponent: Michael O'Brian, representing FCAC (fcac@iccsafe.org)

2018 International Building Code

Revise as follows:

1406.11 Alternate conditions. MCM and MCM systems shall not be required to comply with ~~Sections~~ Section 1406.10.1 through or Section 1406.10.4 provided that such systems comply with ~~Section 1406.11.1, 1406.11.2, 1406.11.3 or 1406.11.4.~~

1406.11.1 Installations up to 40 feet in height. MCM ~~and MCM systems~~ shall ~~not be installed more than be~~ limited to installation up to 40 feet (12 190 mm) in height above grade plane where installed in accordance with Sections 1406.8, 1406.9, 1406.10.2, 1406.10.3 and with Sections 1406.11.1.1 and 1406.11.1.2. Such installations shall not be required to comply with Sections 1406.10.1 or 1406.10.4.

Delete without substitution:

~~**1406.11.2 Installations up to 50 feet in height.** MCM shall not be installed more than 50 feet (15 240 mm) in height above grade where installed in accordance with Sections 1406.11.2.1 and 1406.11.2.2.~~

~~**1406.11.2.1 Self-ignition temperature.** MCM shall have a self-ignition temperature of 650°F (343°C) or greater when tested in accordance with ASTM D1929.~~

~~**1406.11.2.2 Limitations.** Sections of MCM shall not exceed 300 square feet (27.9 m²) in area and shall be separated by not less than 4 feet (1219 mm) vertically.~~

~~**1406.11.3 Installations up to 75 feet in height (Option 1).** MCM shall not be installed more than 75 feet (22 860 mm) in height above grade plane where installed in accordance with Sections 1406.11.3.1 through 1406.11.3.5.~~

~~**Exception:** Buildings equipped throughout with an *automatic sprinkler system* in accordance with Section 903.3.1.1 shall be exempt from the height limitation.~~

~~**1406.11.3.1 Prohibited occupancies.** MCM shall not be permitted on buildings classified as Group A-1, A-2, H, I-2 or I-3 occupancies.~~

~~**1406.11.3.2 Nonfire-resistance-rated exterior walls.** MCM shall not be permitted on *exterior walls* required to have a *fire-resistance rating* by other provisions of this code.~~

~~**1406.11.3.3 Specifications.** MCM shall be required to comply with all of the following:~~

- ~~1. MCM shall have a self-ignition temperature of 650°F (343°C) or greater when tested in accordance with ASTM D1929.~~
- ~~2. MCM shall conform to one of the following combustibility classifications when tested in accordance with ASTM D635:
Class CC1: Materials that have a burning extent of 1 inch (25 mm) or less when tested at a nominal thickness of 0.060 inch (1.5 mm) or in the thickness intended for use.
Class CC2: Materials that have a burning rate of 2¹/₂ inches per minute (1.06 mm/s) or less when tested at a nominal thickness of 0.060 inch (1.5 mm) or in the thickness intended for use.~~

~~**1406.11.3.4 Area limitation and separation.** The maximum area of a single MCM panel and the minimum vertical and horizontal separation requirements for MCM panels shall be as provided for in Table 1406.11.3.4. The maximum percentage of *exterior wall* area of any story covered with MCM panels shall not exceed that indicated in Table 1406.11.3.4 or the percentage of unprotected openings permitted by Section 705.8, whichever is smaller.~~

~~**Exception:** In buildings provided with flame barriers complying with Section 705.8.5 and extending 30 inches (760 mm) beyond the *exterior wall* in the plane of the floor, a vertical separation shall not be required at the floor other than that provided by the vertical thickness of the flame barrier.~~

**TABLE 1406.11.3.4
AREA LIMITATION AND SEPARATION REQUIREMENTS FOR MCM PANELS**

FIRE SEPARATION DISTANCE (feet)	COMBUSTIBILITY CLASS OF MCM	MAXIMUM PERCENTAGE AREA OF EXTERIOR WALL COVERED WITH MCM PANELS	MAXIMUM SINGLE AREA OF MCM PANELS (square feet)	MINIMUM SEPARATION OF MCM PANELS (feet)	
				Vertical	Horizontal
Less than 6	—	Not Permitted	Not Permitted	—	—
6 or more but less than 11	CC1	10	50	8	4
	CC2	Not Permitted	Not Permitted	—	—
11 or more but less than or equal to 30	CC1	25	90	6	4
	CC2	15	70	8	4
More than 30	CC1	50	Not Limited	3 ^a	0
	CC2	50	100	6 ^a	3

For SI: 1 foot = 304.8 mm, 1 square foot = 0.0929 m².

- a. For reductions in the minimum vertical separation, see Section 1406.11.3.4.

1406.11.3.5 Automatic sprinkler system increases. Where the building is equipped throughout with an *automatic sprinkler system* in accordance with Section 903.3.1.1, the maximum percentage area of *exterior wall* of any story covered with MCM panels and the maximum square footage of a single area of MCM panels in Table 1406.11.3.4 shall be increased 100 percent. The area of MCM panels shall not exceed 50 percent of the *exterior wall* area of any story or the area permitted by Section 705.8 for unprotected openings, whichever is smaller.

1406.11.4 Installations up to 75 feet in height (Option 2). MCM shall not be installed more than 75 feet (22 860 mm) in height above grade plane where installed in accordance with Sections 1406.11.4.1 through 1406.11.4.4.

Exception: Buildings equipped throughout with an *automatic sprinkler system* in accordance with Section 903.3.1.1 shall be exempt from the height limitation.

1406.11.4.1 Minimum fire separation distance. MCM shall not be installed on any wall with a fire separation distance less than 30 feet (9 144 mm).

Exception: Where the building is equipped throughout with an *automatic sprinkler system* in accordance with Section 903.3.1.1, the fire separation distance shall be permitted to be reduced to not less than 20 feet (6096 mm).

1406.11.4.2 Specifications. MCM shall be required to comply with all of the following:

1. MCM shall have a self ignition temperature of 650°F (343°C) or greater when tested in accordance with ASTM D1929.
2. MCM shall conform to one of the following combustibility classifications when tested in accordance with ASTM D635:
 - **Class CC1:** Materials that have a burning extent of 1 inch (25 mm) or less when tested at a nominal thickness of 0.060 inch (1.5 mm), or in the thickness intended for use.
 - **Class CC2:** Materials that have a burning rate of 2¹/₂ inches per minute (1.06 mm/s) or less when tested at a nominal thickness of 0.060 inch (1.5 mm), or in the thickness intended for use.

1406.11.4.3 Area and size limitations. The aggregate area of MCM panels shall not exceed 25 percent of the area of any *exterior wall* face of the *story* on which those panels are installed. The area of a single MCM panel installed above the first *story* above grade plane shall not exceed 16 square feet (1.5 m²) and the vertical dimension of a single MCM panel shall not exceed 4 feet (1219 mm).

Exception: Where the building is equipped throughout with an *automatic sprinkler system* in accordance with Section 903.3.1.1, the maximum aggregate area of MCM panels shall be increased to 50 percent of the *exterior wall* face of the *story* on which those panels are installed and there shall not be a limit on the maximum dimension or area of a single MCM panel.

1406.11.4.4 Vertical separations. Flame barriers complying with Section 705.8 and extending 30 inches (762 mm) beyond the *exterior wall* or a vertical separation of not less than 4 feet (1219 mm) in height shall be provided to separate MCM panels located on the *exterior walls* at one-story intervals.

Exception: Buildings equipped throughout with an *automatic sprinkler system* in accordance with Section 903.3.1.1.

Reason:

This proposal eliminates the current code allowances for alternate fire testing for building heights above 40 feet; current code has allowances for a) installations up to 50 feet and b) installations up to 75 feet - Option1 and Option2.

When MCM systems are installed in buildings of Type I through IV construction they always need to be separated from the interior of the building by a thermal barrier, unless they have been tested by one of the special approval tests, such as a room-corner test (NFPA 286, UL 1040 or UL 1715).

This proposal clarifies that, in buildings of such low heights above grade plane (up to 40 feet), testing to NFPA 285 is not required and a Class B (75 flame spread index) in ASTM E84 is sufficient and a Class A is not needed.

The requirements regarding fire resistance rating in 1406.8 must apply also.

This proposal is submitted by the ICC Fire Code Action Committee (FCAC). The FCAC was established by the ICC Board of Directors to pursue opportunities to improve and enhance assigned International Codes with regard to fire safety and hazardous materials in new and existing buildings and facilities and the protection of life and property in wildland urban interface areas. In 2017 the Fire-CAC has held 3 open meetings. In addition, there were numerous conference

calls, Regional Work Group and Task Group meetings for the current code development cycle, which included members of the committees as well as any interested parties, to discuss and debate the proposed changes. Related documentation and reports are posted on the FCAC website at: <https://www.iccsafe.org/codes-tech-support/cs/fire-code-action-committee-fcac/>

This proposal is one in a series of related proposals intended to address different technical changes to Chapter 14. While the Fire Code Committee will consider each proposal independently, the intent is for approval of all proposals in this package which have been submitted as a correlated set of companion code change proposals.

The FCAC analyzed several fatal fires related to exterior façade/curtain wall fires in the development of these new code requirements. The intent of these proposals is to provide a reasonable set of code requirements to ensure fire safety and weather protection for buildings that utilize combustible materials and/or assemblies for the building exterior wall envelope.

1. Grenfell fire, London England:

Buildings Across U.S. Are Wrapped in Same Panels That Fueled Deadly London Fire: <https://www.wsj.com/articles/built-to-burn-thousands-of-buildings-world-wide-are-wrapped-in-combustible-panels-1508858048>

Why Grenfell Tower Burned: Regulators Put Cost Before Safety
<https://www.nytimes.com/2017/06/24/world/europe/grenfell-tower-london-fire.html>

2. Torch Tower Fire, Dubai

https://en.wikipedia.org/wiki/The_Marina_Torch January 8th, 2018

3. Address Hotel Fire, Dubai https://en.wikipedia.org/wiki/The_Address_Downtown_Dubai January 8th, 2018

Cost Impact

The code change proposal will increase the cost of construction .

The elimination of the current allowances allowing use of MCM to up to 75 on almost all buildings will lead to a more expensive fire-tested product being required for application above 40 feet.

Internal ID: 396

FS141-18

IBC: 1406.10, 1406.10.1, 1406.10.2, 1406.10.3

Proponent: Michael O'Brian, Chair, representing FCAC (fcac@iccsafe.org)

2018 International Building Code

Revise as follows:

1406.10 Type I, II, III and IV construction. Where installed on buildings of Type I, II, III and IV construction, metal composite material (MCM systems) shall comply with Sections 1406.10.1 through ~~1406.10.4~~ 1406.10.3, or Section 1406.11.

1406.10.1 Surface-burning characteristics. MCM shall have a *flame spread index* of not more than 25 and a smoke-developed index of not more than 450 when tested ~~as an assembly~~ in the maximum thickness intended for use in accordance with ASTM E84 or UL 723.

1406.10.2 Thermal barriers. MCM shall be separated from the interior of a building by an approved thermal barrier consisting of 1/2 -inch (12.7 mm) gypsum wallboard or ~~a~~ material that is tested in accordance with and meets the acceptance criteria of both the Temperature Transmission Fire Test and the Integrity Fire Test of NFPA 275.

Exceptions:

1. The MCM system is specifically approved based on tests conducted in accordance with NFPA 286 and with the acceptance criteria of Section 803.1.1.1, UL 1040 or UL 1715. Such testing shall be performed with the MCM in the maximum thickness intended for use. The MCM system shall include seams, joints and other typical details used in the installation and shall be tested in the manner intended for use.
2. The MCM is used as elements of balconies and similar projections, architectural trim or embellishments.

Delete without substitution:

~~**1406.10.3 Thermal barrier not required.** The thermal barrier specified for MCM in Section 1406.10.2 is not required where:~~

- ~~1. The MCM system is specifically approved based on tests conducted in accordance with NFPA 286 and with the acceptance criteria of Section 803.1.1.1, UL 1040 or UL 1715. Such testing shall be performed with the MCM in the maximum thickness intended for use. The MCM system shall include seams, joints and other typical details used in the installation and shall be tested in the manner intended for use.~~
- ~~2. The MCM is used as elements of balconies and similar projections, architectural trim or embellishments.~~

Revise as follows:

~~1406.10.4~~**1406.10.3 Full-scale tests.** The MCM system shall be tested in accordance with, and comply with, the acceptance criteria of NFPA 285. Such testing shall be performed on the MCM system with the MCM in the maximum thickness intended for use.

Reason:

The testing for flame spread of the MCM when installed in buildings of Type I, II, III and IV construction needs to be of the MCM itself (i.e. the sandwich panel alone) and not of the system, which includes a series of other components, per the definitions below. That is why the term MCM is being replaced by "metal composite materials" and the phrase "as an assembly" is being removed. This is also consistent with the general testing for "metal composite materials" in section 1406.9.

METAL COMPOSITE MATERIAL (MCM). A factory manufactured panel consisting of metal skins bonded to both faces of a solid plastic core.

METAL COMPOSITE MATERIAL (MCM) SYSTEM. An exterior wall covering fabricated using MCM in a specific assembly including joints, seams, attachments, substrate, framing and other details as appropriate to a particular design.

The code change also moves the requirements to exempt the need from a thermal barrier from Section 1406.10.3 to an

exception to 1406.10.2

This proposal is submitted by the ICC Fire Code Action Committee (FCAC). The FCAC was established by the ICC Board of Directors to pursue opportunities to improve and enhance assigned International Codes with regard to fire safety and hazardous materials in new and existing buildings and facilities and the protection of life and property in wildland urban interface areas. In 2017 the Fire-CAC has held 3 open meetings. In addition, there were numerous conference calls, Regional Work Group and Task Group meetings for the current code development cycle, which included members of the committees as well as any interested parties, to discuss and debate the proposed changes. Related documentation and reports are posted on the FCAC website at: <https://www.iccsafe.org/codes-tech-support/cs/fire-code-action-committee-fcac/>

This proposal is one in a series of related proposals intended to address different technical changes to Chapter 14. While the Fire Code Committee will consider each proposal independently, the intent is for approval of all proposals in this package which have been submitted as a correlated set of companion code change proposals.

The FCAC analyzed several fatal fires related to exterior façade/curtain wall fires in the development of these new code requirements. The intent of these proposals is to provide a reasonable set of code requirements to ensure fire safety and weather protection for buildings that utilize combustible materials and/or assemblies for the building exterior wall envelope.

1. Grenfell fire, London England:

Buildings Across U.S. Are Wrapped in Same Panels That Fueled Deadly London Fire: <https://www.wsj.com/articles/built-to-burn-thousands-of-buildings-world-wide-are-wrapped-in-combustible-panels-1508858048>

Why Grenfell Tower Burned: Regulators Put Cost Before Safety
<https://www.nytimes.com/2017/06/24/world/europe/grenfell-tower-london-fire.html>

2. Torch Tower Fire, Dubai

https://en.wikipedia.org/wiki/The_Marina_Torch January 8th, 2018

3. Address Hotel Fire, Dubai https://en.wikipedia.org/wiki/The_Address_Downtown_Dubai January 8th, 2018

Cost Impact

The code change proposal will not increase or decrease the cost of construction .

This proposal simply clarifies that the code is requiring the MCM panel to be tested and is editorial for better use and understanding of the requirements in this section

Internal ID: 441

FS142-18

IBC: 1406.11, 1406.11.1, 1406.11.4, 1406.11.4.1, 1406.11.4.2, 1406.11.4.3, 1406.11.4.4

Proponent: Marcelo Hirschler, GBH International, representing GBH International (gbhint@aol.com)

2018 International Building Code

Revise as follows:

1406.11 Alternate conditions. MCM and MCM systems shall ~~not~~ be required to comply with Sections 1406.10.1 through 1406.10.4 provided that such systems comply with Section 1406.11.1, 1406.11.2, 1406.11.3 or 1406.11.4 or 1406.11.3, as a function of the height of the installation.

1406.11.1 Installations up to 40 feet in height. MCM shall ~~not~~ be installed more than permitted to be installed up to 40 feet (12 190 mm) in height above grade plane where installed in accordance with Sections 1406.8, 1406.9, 1406.10.2, 1406.10.3 and with Sections 1406.11.1.1 and 1406.11.1.2.

1406.11.1.1 Fire separation distance of 5 feet or less. Where the *fire separation distance* is 5 feet (1524 mm) or less, the area of MCM shall not exceed 10 percent of the *exterior wall surface*.

1406.11.1.2 Fire separation distance greater than 5 feet. Where the *fire separation distance* is greater than 5 feet (1524 mm), the area of *exterior wall surface coverage* using MCM shall not be limited.

Delete without substitution:

~~**1406.11.4 Installations up to 75 feet in height (Option 2).** MCM shall not be installed more than 75 feet (22 860 mm) in height above grade plane where installed in accordance with Sections 1406.11.4.1 through 1406.11.4.4.~~

~~**Exception:** Buildings equipped throughout with an *automatic sprinkler system* in accordance with Section 903.3.1.1 shall be exempt from the height limitation.~~

~~**1406.11.4.1 Minimum fire separation distance.** MCM shall not be installed on any wall with a fire separation distance less than 30 feet (9 144 mm).~~

~~**Exception:** Where the building is equipped throughout with an *automatic sprinkler system* in accordance with Section 903.3.1.1, the fire separation distance shall be permitted to be reduced to not less than 20 feet (6 096 mm).~~

~~**1406.11.4.2 Specifications.** MCM shall be required to comply with all of the following:~~

- ~~1. MCM shall have a self ignition temperature of 650°F (343°C) or greater when tested in accordance with ASTM D1929.~~
- ~~2. MCM shall conform to one of the following combustibility classifications when tested in accordance with ASTM D635:
 - ~~• **Class CC1:** Materials that have a burning extent of 1 inch (25 mm) or less when tested at a nominal thickness of 0.060 inch (1.5 mm), or in the thickness intended for use.~~
 - ~~• **Class CC2:** Materials that have a burning rate of 2¹/₂ inches per minute (1.06 mm/s) or less when tested at a nominal thickness of 0.060 inch (1.5 mm), or in the thickness intended for use.~~~~

~~**1406.11.4.3 Area and size limitations.** The aggregate area of MCM panels shall not exceed 25 percent of the area of any *exterior wall face* of the *story* on which those panels are installed. The area of a single MCM panel installed above the first *story* above grade plane shall not exceed 16 square feet (1.5 m²) and the vertical dimension of a single MCM panel shall not exceed 4 feet (1219 mm).~~

~~**Exception:** Where the building is equipped throughout with an *automatic sprinkler system* in accordance with Section 903.3.1.1, the maximum aggregate area of MCM panels shall be increased to 50 percent of the *exterior wall face* of the *story* on which those panels are installed and there shall not be a limit on the maximum dimension or area of a single MCM panel.~~

~~**1406.11.4.4 Vertical separations.** Flame barriers complying with Section 705.8 and extending 30 inches (762 mm) beyond the *exterior wall* or a vertical separation of not less than 4 feet (1219 mm) in height shall be provided to separate MCM panels located on the *exterior walls* at one-story intervals.~~

~~**Exception:** Buildings equipped throughout with an *automatic sprinkler system* in accordance with Section 903.3.1.1.~~

Reason:

If the proposal to eliminate all alternate installations of MCM systems is believed to be too severe a change, a set of three proposals would provide adequate safety for use of these systems. This proposal handles all requirements for MCMs up to 40 ft in height and is followed by proposals that would handle requirements between 40 ft and 50 ft and requirements for installations between 50 ft and 75 ft.

The charging paragraph is proposed to be made into a positive requirement so that each subsection describes the requirements for such installations.

When MCM systems are installed in buildings of Type I through IV construction they always need to be separated from the interior of the building by a thermal barrier, unless they have been tested by one of the special approval tests, such as a room-corner test (NFPA 286, UL 1040 or UL 1715), as explained in sections 1406.10.2 and 1406.10.3. This proposal excludes MCM systems on buildings of such low heights above grade plane from testing to NFPA 285 and requires them to comply with a Class B (75 flame spread index) in ASTM E84 is sufficient and a Class A (as would be required in Section 1406.10.1) is not needed. The requirements regarding fire resistance rating in 1406.8 must apply also.

The revision states which sections need to be complied with and, therefore, a specific statement that MCM systems in installations up to 40 feet in height do not need to comply with NFPA 285 (section 1406.10.4) is not necessary.

The section 1406.11.4 is proposed to be deleted without substitution because both sections 1406.11.3 and 1406.11.4 deal with installations in buildings up to 75 feet in height (and even higher) and the two options need to be consolidated.

No specific information is needed about installations above 75 feet because they need to comply with the general requirements that the entire exterior wall envelope must be tested to NFPA 285 and meet the corresponding requirements.

Cost Impact

The code change proposal will increase the cost of construction .

This proposal would impose additional fire safety requirements for MCM systems.

Internal ID: 793

FS143-18

IBC: 1406.11.2, 1406.11.2.1, 1406.11.4, 1406.11.4.1, 1406.11.4.2, 1406.11.4.3, 1406.11.4.4

Proponent: Marcelo Hirschler, GBH International, representing GBH International (gbhint@aol.com)

2018 International Building Code

Revise as follows:

1406.11.2 Installations up to 50 feet in height. MCM shall ~~not be permitted to~~ be installed ~~more than up to~~ 50 feet (15 240mm) in height above grade ~~plane~~ where installed in accordance with Sections ~~1406.11.2.1 and 1406.11.2.2~~ 1406.8, 1406.9, 1406.10.1 through 1406.10.3 and with Section 1406.11.2.1. In such installations, the MCM systems on their own shall not be required to comply with Section 1406.10.4, but the entire exterior wall envelope shall be required to be tested with and comply with the acceptance criteria of NFPA 285.

Delete without substitution:

~~**1406.11.2.1 Self-ignition temperature.** MCM shall have a self-ignition temperature of 650°F (343°C) or greater when tested in accordance with ASTM D1929.~~

Revise as follows:

~~**1406.11.2.2**~~ **1406.11.2.1 Limitations.** Sections of MCM shall not exceed 300 square feet (27.9 m²) in area and shall be separated by not less than 4 feet (1219 mm) vertically.

Delete without substitution:

~~**1406.11.4 Installations up to 75 feet in height (Option 2).** MCM shall not be installed more than 75 feet (22 860 mm) in height above grade plane where installed in accordance with Sections 1406.11.4.1 through 1406.11.4.4.~~

~~**Exception:** Buildings equipped throughout with an automatic sprinkler system in accordance with Section 903.3.1.1 shall be exempt from the height limitation.~~

~~**1406.11.4.1 Minimum fire separation distance.** MCM shall not be installed on any wall with a fire separation distance less than 30 feet (9 144 mm).~~

~~**Exception:** Where the building is equipped throughout with an automatic sprinkler system in accordance with Section 903.3.1.1, the fire separation distance shall be permitted to be reduced to not less than 20 feet (6 096 mm).~~

~~**1406.11.4.2 Specifications.** MCM shall be required to comply with all of the following:~~

- ~~1. MCM shall have a self-ignition temperature of 650°F (343°C) or greater when tested in accordance with ASTM D1929.~~
- ~~2. MCM shall conform to one of the following combustibility classifications when tested in accordance with ASTM D635:~~
 - ~~• **Class CC1:** Materials that have a burning extent of 1 inch (25 mm) or less when tested at a nominal thickness of 0.060 inch (1.5 mm), or in the thickness intended for use.~~
 - ~~• **Class CC2:** Materials that have a burning rate of 2¹/₂ inches per minute (1.06 mm/s) or less when tested at a nominal thickness of 0.060 inch (1.5 mm), or in the thickness intended for use.~~

~~**1406.11.4.3 Area and size limitations.** The aggregate area of MCM panels shall not exceed 25 percent of the area of any exterior wall face of the story on which those panels are installed. The area of a single MCM panel installed above the first story above grade plane shall not exceed 16 square feet (1.5 m²) and the vertical dimension of a single MCM panel shall not exceed 4 feet (1219 mm).~~

~~**Exception:** Where the building is equipped throughout with an automatic sprinkler system in accordance with Section 903.3.1.1, the maximum aggregate area of MCM panels shall be increased to 50 percent of the exterior wall face of the story on which those panels are installed and there shall not be a limit on the maximum dimension or area of a single MCM panel.~~

~~**1406.11.4.4 Vertical separations.** Flame barriers complying with Section 705.8 and extending 30 inches (762 mm) beyond the exterior wall or a vertical separation of not less than 4 feet (1219 mm) in height shall be provided to separate MCM panels located on the exterior walls at one-story intervals.~~

Exception: Buildings equipped throughout with an *automatic sprinkler system* in accordance with Section 903.3.1.1.

Reason:

If it is believed that eliminating all alternate provisions for the use of MCM systems is too severe a change, this is the second of three proposals that provide an alternate approach to use these systems with added fire safety requirements. This proposal deals with systems to be installed at heights of 40 to 50 ft.

When MCM systems are installed in buildings of Type I through IV construction they always need to be separated from the interior of the building by a thermal barrier, unless they have been tested by one of the special approval tests, such as a room-corner test (NFPA 286, UL 1040 or UL 1715). Also, in buildings above 40 ft (and up to 50 ft) a Class A (25 flame spread index) in ASTM E84 is required but that testing to NFPA 285 is not required if there is a sufficient area limitation. The section on ignition temperature is proposed to be eliminated because it should apply to all MCM systems. The requirements regarding fire resistance rating in 1406.8 must apply also. The requirements regarding ignition temperature need to apply to all MCM, irrespective of height where they are installed.

The MCM systems themselves are not required to be tested to NFPA 285. However, the proposed wording clarifies that the entire exterior wall envelope must be tested to NFPA 285.

The alternate approach in sections 1406.11.4 is proposed to be deleted because it does not provide sufficient fire safety.

Cost Impact

The code change proposal will increase the cost of construction .

This proposal imposes additional fire safety requirements for MCM systems.

Internal ID: 795

FS144-18

IBC: 1406.11.3, 1406.11.3.1 (New), 1406.11.3.1.1, 1406.11.3.1.2, 1406.11.3.3, 1406.11.3.1.3, TABLE 1406.11.3.1.3, 1406.11.3.1.4, 1406.11.3.2 (New), 1406.11.3.2.1 (New), 1406.11.3.2.2 (New)

Proponent: Marcelo Hirschler, GBH International, representing GBH International (gbhint@aol.com)

2018 International Building Code

Revise as follows:

1406.11.3 Installations between 50 ft and up to 75 feet in height (Option 1) height. ~~MCM-MCMs shall not be installed more than be permitted to be installed between 50 feet (15 240 mm) and up to 75 feet (22 860 mm) in height above grade plane where installed in accordance with Sections 1406.11.3.1 through 1406.11.3.5.~~ **Exception:** ~~Buildings equipped throughout with an automatic sprinkler system in accordance with Section 903.3.1.1 shall be exempt from the height limitation.~~

~~1406.8, 1406.9, 1406.10.1, 1406.10.2, 1406.10.3, and also either 1406.11.3.1 or 1406.11.3.2. In such installations, the MCMs on their own shall not be required to comply with Section 1406.10.4, but the entire exterior wall envelope shall be required to be tested with, and comply with the acceptance criteria of, NFPA 285.~~

Add new text as follows:

1406.11.3.1 Fire separations not exceeding 30 ft. For buildings with fire separations not exceeding 30 feet (9 144 mm), MCMs shall be permitted up to a height of 75 feet where installed in accordance with Sections 1406.11.3.1.1 through 1406.11.3.1.4.

Revise as follows:

~~1406.11.3.1~~**1406.11.3.1.1 Prohibited occupancies.** ~~MCM-MCMs shall not be permitted on buildings classified as Group A-1, A-2, H, I-2 or I-3 occupancies.~~

~~1406.11.3.2~~**1406.11.3.1.2 Nonfire-resistance-rated exterior walls.** ~~MCM-MCMs shall not be permitted on exterior walls required to have a fire-resistance rating by other provisions of this code.~~

Delete without substitution:

~~1406.11.3.3 Specifications.~~ ~~MCM shall be required to comply with all of the following:~~

- ~~1. MCM shall have a self ignition temperature of 650°F (343°C) or greater when tested in accordance with ASTM D1929.~~
- ~~2. MCM shall conform to one of the following combustibility classifications when tested in accordance with ASTM D635:~~

~~Class CC1: Materials that have a burning extent of 1 inch (25 mm) or less when tested at a nominal thickness of 0.060 inch (1.5 mm) or in the thickness intended for use.~~

~~Class CC2: Materials that have a burning rate of 2¹/₂ inches per minute (1.06 mm/s) or less when tested at a nominal thickness of 0.060 inch (1.5 mm) or in the thickness intended for use.~~

Revise as follows:

~~1406.11.3.4~~**1406.11.3.1.3 Area limitation and separation.** ~~The maximum area of a single MCM panel system and the minimum vertical and horizontal separation requirements for MCM panels systems shall be as provided for in Table 1406.11.3.4.~~ 1406.11.3.1.3. The maximum percentage of exterior wall area on each side of any story covered with MCM panels systems shall not exceed that indicated in Table 1406.11.3.4-1406.11.3.1.3 or the percentage of unprotected openings permitted by Section 705.8, whichever is smaller.

Exception: In buildings provided with flame barriers complying with Section 705.8.5 and extending 30 inches (760 mm) beyond the exterior wall in the plane of the floor, a vertical separation shall not be required at the floor other than that provided by the vertical thickness of the flame barrier.

**TABLE 1406.11.3.4-1406.11.3.1.3
AREA LIMITATION AND SEPARATION REQUIREMENTS FOR MCM PANEL SYSTEMS**

FIRE SEPARATION DISTANCE (feet)	COMBUSTIBILITY CLASS OF MCM	MAXIMUM PERCENTAGE AREA OF EXTERIOR WALL COVERED WITH MCM SYSTEMS	MAXIMUM SINGLE AREA OF MCM SYSTEMS (square feet)	MINIMUM SEPARATION OF MCM SYSTEMS (feet)	
				Vertical	Horizontal
Less than 6	-	Not Permitted	Not Permitted	-	-
6 or more but less than 11	CC1	10	50	8	4
	CC2	Not Permitted	Not Permitted	Not Permitted	Not Permitted
11 or more but less than or equal to 30	CC1	25	90	6	4
	CC2	Not Permitted	Not Permitted	Not Permitted	Not Permitted
More than 30	CC1	50	Not Limited	3 ^a	0
	CC2	Not Permitted	Not Permitted	Not Permitted	Not Permitted

For SI: 1 foot = 304.8 mm, 1 square foot = 0.0929 m².

- a. For reductions in the minimum vertical separation, see Section ~~1406.11.3.4~~1406.11.3.1.3.

~~1406.11.3.5~~1406.11.3.1.4 **Automatic sprinkler system increases.** Where the building is equipped throughout with an *automatic sprinkler system* in accordance with Section 903.3.1.1, the maximum percentage area of *exterior wall on each side* of any story covered with MCM ~~panels~~systems and the maximum square footage of a single area of MCM ~~panels~~systems in Table ~~1406.11.3.4~~1406.11.3.1.3 shall be increased 100 percent. The area of MCM ~~panels~~systems shall not exceed 50 percent of the *exterior wall area on each side* of any story or the area permitted by Section 705.8 for unprotected openings, whichever is smaller.

Add new text as follows:

1406.11.3.2 Fire separations exceeding 30 feet.. For buildings with fire separations exceeding 30 feet (9 144 mm), MCM shall be permitted where installed in accordance with Sections 1406.11.3.2.1 and 1406.11.3.2.2.

Exception: Where the building is equipped throughout with an automatic sprinkler system in accordance with Section 903.3.1.1, the maximum aggregate area of MCM systems shall be increased to 50 percent of the exterior wall face on each side of the story on which those MCM systems are installed and there shall not be a limit on the maximum dimension or area of a single MCM system.

1406.11.3.2.1 Area and size limitations. . The aggregate area of MCM systems shall not exceed 25 percent of the area of any exterior wall face of the story on which those MCM systems are installed. The area of a single MCM system installed above the first story above grade plane shall not exceed 16 square feet (1.5 m²) and the vertical dimension of a single MCM system shall not exceed 4 feet (1219 mm).

1406.11.3.2.2 Vertical separations. Flame barriers complying with Section 705.8 and extending 30 inches (762 mm) beyond the exterior wall or a vertical separation of not less than 4 feet (1219 mm) in height shall be provided to separate MCM systems located on the exterior walls at one-story intervals.

Reason:

This proposal contains all the requirements for installation of MCMs above 50 feet, if the committee is inclined not to prohibit all such installations. It eliminates the concept of "option 1" and "option 2".

The proposal does not permit exceptions for MCM installations based purely on the use of sprinklers inside the building. The proposal eliminates sprinkler exceptions from present sections 1406.11.3, 1406.11.4, 1406.11.4.1 and 1406.11.4.4. That means that there will be no blanket sprinkler exceptions for height limitations, vertical separations or fire separation distances. The reason for this is that sprinklers inside a building will not affect flame spread along the outside of the building and therefore the presence of sprinklers inside the building should not provide exception from testing to NFPA 285 or from height limitations. Sprinklers do not control outside fires. Allowance is retained for increasing areas of MCMs when the building is fully protected by sprinklers. It seems reasonable that sprinkler protection should allow greater areas of MCM use.

The proposal requires that any time the installation exceeds 75 feet the MCM system itself must be tested to NFPA 285 (as well as testing the entire exterior wall envelope to NFPA 285).

For installations between 50 ft and 75 feet it allows two options depending on whether the separation between buildings is over or under 30 feet.

For separations below 30 feet allowances are made with much more restricted areas and MCM systems are not allowed to be used if they only comply with CC2. Also it is made clear that the area limitations apply to every side of the building. Also, there are prohibited occupancies (A-1, A-2, H, I-2 and I-3, just like in the 2018 code) and MCMs cannot be installed if a fire resistance rating is required.

For separations above 30 feet MCMs are permitted with some severe area limitations, mirroring what is allowed today, but without the excessive exceptions for sprinklers inside the building.

The full text as the code would read if this is approved is attached.

Cost Impact

The code change proposal will increase the cost of construction .

This proposal, which is the third of a group of 3 proposals on MCMs, will require more fire testing of these systems and result in better fire safety.

Internal ID: 848

FS145-18

IBC: 1406.11.3, 1406.11.4

Proponent: Michael O'Brian, Chair, representing FCAC (FCAC@iccsafe.org)

2018 International Building Code

Revise as follows:

1406.11.3 Installations up to 75 feet in height (Option 1). MCM shall not be installed more than 75 feet (22 860 mm) in height above grade plane where installed in accordance with Sections 1406.11.3.1 through 1406.11.3.5.

~~**Exception:** Buildings equipped throughout with an automatic sprinkler system in accordance with Section 903.3.1.1 shall be exempt from the height limitation.~~

1406.11.4 Installations up to 75 feet in height (Option 2). MCM shall not be installed more than 75 feet (22 860 mm) in height above grade plane where installed in accordance with Sections 1406.11.4.1 through 1406.11.4.4.

~~**Exception:** Buildings equipped throughout with an automatic sprinkler system in accordance with Section 903.3.1.1 shall be exempt from the height limitation.~~

Reason:

This code change proposal removes the height exception for sprinklered buildings

MCM systems are the only systems in Chapter 14 of the IBC where the presence of sprinklers inside the building is the reason to eliminate the height and coverage limitations associated with fires along the exterior wall envelope. Such an exception that allows buildings of unlimited height to be used with MCM systems as part of the exterior wall envelope based on the presence of sprinklers inside the building is inappropriate because there is no fire department access for those buildings above 75 feet Note that installations that comply with the 1406.11 sections are not required to be tested to NFPA 285. This proposal removes the blanket sprinkler exceptions for height limitations. The reason for this is 1) that interior sprinkler systems for high rise buildings are not intended to control outside exposure fires and 2) therefore, sprinklers inside a building have a limited affect upon flame spread along the outside of the building. the presence of sprinklers inside the building should not provide a full exception from testing to NFPA 285 or from height limitations necessary to ensure a minimum level of safety.

According to an NFPA study published in 2014 (Fire Hazards of Exterior Wall Assemblies Containing Combustible Components), slightly more than half of the exterior facade fires originated from interior ignition. Sprinklers will help restrict an interior fire from reaching the exterior facade, but will have limited effect on exterior ignition or fire spread across combustible exterior wall assemblies..

Also keep in mind that when these fires occur, occupants have little choice but to evacuate and stairs are not designed for full building evacuation. It can be expected that evacuating occupants will encounter stairs overflowing with other evacuating occupants. As observed during the 63 story Address Hotel fire in Dubai on New Year's Eve 2015, these situations increase the tendency to panic and cause crushes. In addition, most stair pressurization systems take outside air from the roof, which can be expected to bring in contaminated air, decreasing the level of comfort for evacuating occupants. And, those aren't even the worst scenarios. When occupants evacuate stair enclosures at grade, they are greeted with flaming debris raining down on them.

This proposal is submitted by the ICC Fire Code Action Committee (FCAC). The FCAC was established by the ICC Board of Directors to pursue opportunities to improve and enhance assigned International Codes with regard to fire safety and hazardous materials in new and existing buildings and facilities and the protection of life and property in wildland urban interface areas. In 2017 the Fire-CAC has held 3 open meetings. In addition, there were numerous conference calls, Regional Work Group and Task Group meetings for the current code development cycle, which included members of the committees as well as any interested parties, to discuss and debate the proposed changes. Related documentation and reports are posted on the FCAC website at: <https://www.iccsafe.org/codes-tech-support/cs/fire-code-action-committee-fcac/>

This proposal is one in a series of related proposals intended to address different technical changes to Chapter 14. While the Fire Code Committee will consider each proposal independently, the intent is for approval of all proposals in this package which have been submitted as a correlated set of companion code change proposals.

The FCAC analyzed several fatal fires related to exterior façade/curtain wall fires in the development of these new code requirements. The intent of these proposals is to provide a reasonable set of code requirements to ensure fire safety and weather protection for buildings that utilize combustible materials and/or assemblies for the building

exterior wall envelope.

1. Grenfell fire, London England:

Buildings Across U.S. Are Wrapped in Same Panels That Fueled Deadly London Fire: <https://www.wsj.com/articles/built-to-burn-thousands-of-buildings-world-wide-are-wrapped-in-combustible-panels-1508858048>

Why Grenfell Tower Burned: Regulators Put Cost Before Safety
<https://www.nytimes.com/2017/06/24/world/europe/grenfell-tower-london-fire.html>

2. Torch Tower Fire, Dubai

https://en.wikipedia.org/wiki/The_Marina_Torch January 8th, 2018

3. Address Hotel Fire, Dubai https://en.wikipedia.org/wiki/The_Address_Downtown_Dubai January 8th, 2018

Cost Impact

The code change proposal will increase the cost of construction .

The elimination of the exception allowing use of MCM to any height on a sprinklered building may lead to a more expensive fire-tested product being required for application above 75 feet.

Internal ID: 394

FS146-18

IBC: 1406.13

Proponent: Michael O'Brian, Chair, representing FCAC (FCAC@iccsafe.org)

2018 International Building Code

Revise as follows:

1406.13 Foam plastic insulation. Where MCM systems are included in an exterior wall envelope containing foam plastic insulation, the exterior wall envelope shall also comply with the requirements of Section 2603.

Reason:

This code change proposal clarifies when foam plastic insulation is permitted. By definition, foam plastic cannot be contained within the MCM system, but foam plastic can be part of the same exterior wall envelope that also includes the MCM system and the entire exterior wall envelope must then be tested appropriately as indicated in section 2603

The definition of metal composite material (MCM), shown below, does not allow MCMs to contain foam plastic insulation. The definition of metal composite material (MCM) system, also shown below, indicates that this is an exterior wall covering. However, section 2603.5 indicates that, whenever foam plastic insulation is included in exterior walls (meaning exterior wall envelopes) the exterior wall envelope must be tested to NFPA 285. Moreover, sections 2603.3 and 2603.4 indicate that the foam plastic insulation itself must meet the requirements of class B (flame spread index of 75 and smoke developed index of 450) when tested to ASTM E84, and the foam plastic insulation must be separated from the interior of the building by a thermal barrier (with some exceptions).

METAL COMPOSITE MATERIAL (MCM). A factory manufactured panel consisting of metal skins bonded to both faces of a solid plastic core.

METAL COMPOSITE MATERIAL (MCM) SYSTEM. An exterior wall covering fabricated using MCM in a specific assembly including joints, seams, attachments, substrate, framing and other details as appropriate to a particular design.

EXTERIOR WALL ENVELOPE. A system or assembly of exterior wall components, including exterior wall finish materials, that provides protection of the building structural members, including framing and sheathing materials, and conditioned interior space, from the detrimental effects of the exterior environment.

This proposal is submitted by the ICC Fire Code Action Committee (FCAC). The FCAC was established by the ICC Board of Directors to pursue opportunities to improve and enhance assigned International Codes with regard to fire safety and hazardous materials in new and existing buildings and facilities and the protection of life and property in wildland urban interface areas. In 2017 the Fire-CAC has held 3 open meetings. In addition, there were numerous conference calls, Regional Work Group and Task Group meetings for the current code development cycle, which included members of the committees as well as any interested parties, to discuss and debate the proposed changes. Related documentation and reports are posted on the FCAC website at: <https://www.iccsafe.org/codes-tech-support/cs/fire-code-action-committee-fcac/>

This proposal is one in a series of related proposals intended to address different technical changes to Chapter 14. While the Fire Code Committee will consider each proposal independently, the intent is for approval of all proposals in this package which have been submitted as a correlated set of companion code change proposals.

The FCAC analyzed several fatal fires related to exterior façade/curtain wall fires in the development of these new code requirements. The intent of these proposals is to provide a reasonable set of code requirements to ensure fire safety and weather protection for buildings that utilize combustible materials and/or assemblies for the building exterior wall envelope.

1. Grenfell fire, London England:

Buildings Across U.S. Are Wrapped in Same Panels That Fueled Deadly London Fire: <https://www.wsj.com/articles/built-to-burn-thousands-of-buildings-world-wide-are-wrapped-in-combustible-panels-1508858048>

Why	Grenfell	Tower	Burned:	Regulators	Put	Cost	Before	Safety

<https://www.nytimes.com/2017/06/24/world/europe/grenfell-tower-london-fire.html>

2. Torch Tower Fire, Dubai

https://en.wikipedia.org/wiki/The_Marina_Torch January 8th, 2018

3. Address Hotel Fire, Dubai https://en.wikipedia.org/wiki/The_Address_Downtown_Dubai January 8th, 2018

Cost Impact

The code change proposal will not increase or decrease the cost of construction .

This proposal is simply editorial and clarification.

Internal ID: 395

FS147-18

IBC: 1408.10.3

Proponent: Michael O'Brian, Chair, representing FCAC (FCAC@iccsafe.org)

2018 International Building Code

Revise as follows:

1408.10.2 Thermal barriers. HPL shall be separated from the interior of a building by an approved thermal barrier consisting of 1/2-inch (12.7 mm) gypsum wallboard or a material that is tested in accordance with and meets the acceptance criteria of both the Temperature Transmission Fire Test and the Integrity Fire Test of NFPA 275.

1408.10.3 Thermal barrier not required. The thermal barrier specified for HPL in Section 1408.10.2 is not required where:

1. The HPL system is specifically approved based on tests conducted in accordance with NFPA 286, and with the acceptance criteria of Section 803.1.2.1, or with UL 1040 or UL 1715. Such testing shall be performed with the HPL in the minimum and maximum thicknesses intended for use. The HPL system shall include seams, joints and other typical details used in the installation and shall be tested in the manner intended for use.
2. The HPL is used as elements of balconies and similar projections, architectural *trim* or embellishments.

Reason:

This code change proposal makes a revision regarding the reference to testing in accordance with UL 1040 and UL 1715. The references are retained but the option is added to use NFPA 286, with the corresponding criteria (in section 803.1.1.1), to be consistent with other references to UL 1040 and UL 1715.

NFPA 286 was developed long after UL 1040 and UL 1715 and was not therefore included in every section of the code. However, now NFPA 286 is used much more widely than UL 1040 or UL 1715. No other change is made in this proposal.

This proposal is submitted by the ICC Fire Code Action Committee (FCAC). The FCAC was established by the ICC Board of Directors to pursue opportunities to improve and enhance assigned International Codes with regard to fire safety and hazardous materials in new and existing buildings and facilities and the protection of life and property in wildland urban interface areas. In 2017 the Fire-CAC has held 3 open meetings. In addition, there were numerous conference calls, Regional Work Group and Task Group meetings for the current code development cycle, which included members of the committees as well as any interested parties, to discuss and debate the proposed changes. Related documentation and reports are posted on the FCAC website at: <https://www.iccsafe.org/codes-tech-support/cs/fire-code-action-committee-fcac/>

This proposal is one in a series of related proposals intended to address different technical changes to Chapter 14. While the Fire Code Committee will consider each proposal independently, the intent is for approval of all proposals in this package which have been submitted as a correlated set of companion code change proposals.

The FCAC analyzed several fatal fires related to exterior façade/curtain wall fires in the development of these new code requirements. The intent of these proposals is to provide a reasonable set of code requirements to ensure fire safety and weather protection for buildings that utilize combustible materials and/or assemblies for the building exterior wall envelope.

1. Grenfell fire, London England:

Buildings Across U.S. Are Wrapped in Same Panels That Fueled Deadly London Fire: <https://www.wsj.com/articles/built-to-burn-thousands-of-buildings-world-wide-are-wrapped-in-combustible-panels-1508858048>

Why	Grenfell	Tower	Burned:	Regulators	Put	Cost	Before	Safety

<https://www.nytimes.com/2017/06/24/world/europe/grenfell-tower-london-fire.html>

2. Torch Tower Fire, Dubai

https://en.wikipedia.org/wiki/The_Marina_Torch January 8th, 2018

3. Address Hotel Fire, Dubai https://en.wikipedia.org/wiki/The_Address_Downtown_Dubai January 8th, 2018

Cost Impact

The code change proposal will not increase or decrease the cost of construction .

This proposal adds a reference to NFPA 286 which is a comparable test to the existing UL tests and the rest of the

change is editorial for clarification.

Internal ID: 399

FS148-18

IBC: 1408.10.3

Proponent: Marcelo Hirschler, GBH International, representing GBH International (gbhint@aol.com)

2018 International Building Code

Revise as follows:

1408.10.3 Thermal barrier not required. The thermal barrier specified for HPL in Section 1408.10.2 is not required where:

1. The HPL system is specifically approved based on tests conducted in accordance with NFPA 286, and with the acceptance criteria of Section 803.1.2.1, or with UL 1040 or UL 1715. Such testing shall be performed with the HPL in the minimum and maximum thicknesses intended for use. The HPL system shall include seams, joints and other typical details used in the installation and shall be tested in the manner intended for use.
2. The HPL is used as elements of balconies and similar projections, architectural *trim* or embellishments.

Reason:

This proposal makes a revision regarding the reference to testing in accordance with UL 1040 and UL 1715. The references are retained but the option is added to use NFPA 286, with the corresponding criteria (in section 803.1.2.1), to be consistent with other references to UL 1040 and UL 1715. NFPA 286 was developed long after UL 1040 and UL 1715 and was not therefore included in every section of the code. However, now NFPA 286 is used much more widely than UL 1040 or UL 1715.

Cost Impact

The code change proposal will decrease the cost of construction .

This proposal offers an additional option for fire testing, which is likely to be less expensive and more modern.

Internal ID: 1171

FS149-18

IBC: 1408.10.4.1 (New), 2603.5.5.1 (New), Chapter 35

Proponent: John Harrington, FM Global, representing FM Global (john.harrington@fmglobal.com)

2018 International Building Code

1408.10.4 Full-scale tests. The HPL system shall be tested in accordance with, and comply with, the acceptance criteria of NFPA 285. Such testing shall be performed on the HPL system with the HPL in the minimum and maximum thicknesses intended for use.

Add new text as follows:

1408.10.4.1 Window Protection. Where window openings are provided within the installed wall assembly, they shall be covered as follows:

1. Where the assembly was tested per NFPA 285, provide protection as provided in the actual test.
2. Where the assembly was tested per ANSI/FM 4880, provide minimum 20 ga. (0.03595 in., 0.9 mm) steel flashing around the window opening, fastened at a maximum spacing of 16 inches. (406 mm) on center into the wall structure using minimum no. 10 (5 mm) screws.

2603.5.5 Vertical and lateral fire propagation. The exterior wall assembly shall be tested in accordance with and comply with the acceptance criteria of NFPA 285.

Exceptions:

1. One-story buildings complying with Section 2603.4.1.4.
2. Wall assemblies where the foam plastic insulation is covered on each face by not less than 1-inch (25 mm) thickness of masonry or concrete and meeting one of the following:
 - 2.1. There is no airspace between the insulation and the concrete or masonry.
 - 2.2. The insulation has a flame spread index of not more than 25 as determined in accordance with ASTM E84 or UL 723 and the maximum airspace between the insulation and the concrete or masonry is not more than 1 inch (25 mm).

2603.5.5.1 Window protection. Where window openings are provided within the installed wall assembly, they shall be covered as follows:

1. Where the assembly was tested per NFPA 285, provide protection as provided in the actual test.
2. Where the assembly was tested per ANSI/FM 4880, provide minimum 20 ga. (0.03595 in., 0.9 mm) steel flashing around the window opening, fastened at a maximum spacing of 16 in. (406 mm) on center into the wall structure using no. (5 mm) screws.

Update standard(s) as follows:

FM

FM Approvals
Headquarters Office 1151 Boston-
Providence Turnpike P.O. Box 9102
Norwood MA 02062

4880-2015~~2017~~:

Approval Standard for Class 1 Fire Rating of Building Panels or Interior Finish Materials

Reason:

Protection against fire exposure to the wall assembly cross-section around window openings must be provided in the installation to prevent fire spread within the cavity of the wall assembly.

Cost Impact

The code change proposal will increase the cost of construction .

Minimal cost increase for additional materials in walls so as to prevent fire spread within the wall cavity.

Internal ID: 1918

FS150-18

IBC: 1408.11, 1408.11.1, 1408.11.2, 1408.11.2.1, 1408.11.2.2

Proponent: Michael O'Brian, Chair, representing FCAC (FCAC@iccsafe.org)

2018 International Building Code

Revise as follows:

1408.11 Alternate conditions. HPL and HPL systems shall not be required to comply with Sections 1408.10.1 through 1408.10.4 provided that such systems comply with Section 1408.11.1 ~~or 1408.11.2.~~

1408.11.1 Installations up to 40 feet in height. HPL shall ~~not be installed more than permitted to be installed up to~~ 40 feet (12 190 mm) in height above grade plane where installed in accordance with ~~Sections 1408.11.1.1 and 1408.11.1.2.~~ Section 1408.11.1.1 or with Section 1408.11.1.2.

1408.11.1.1 Fire separation distance of 5 feet or less. Where the fire separation distance is 5 feet (1524 mm) or less, the area of HPL shall not exceed 10 percent of the *exterior wall* surface.

1408.11.1.2 Fire separation distance greater than 5 feet. Where the fire separation distance is greater than 5 feet (1524 mm), the area of *exterior wall* surface coverage using HPL shall not be limited.

Delete without substitution:

~~**1408.11.2 Installations up to 50 feet in height.** HPL shall not be installed more than 50 feet (15 240 mm) in height above grade plane where installed in accordance with Sections 1408.11.2.1 and 1408.11.2.2.~~

~~**1408.11.2.1 Self-ignition temperature.** HPL shall have a self-ignition temperature of 650°F (343°C) or greater when tested in accordance with ASTM D1929.~~

~~**1408.11.2.2 Limitations.** Sections of HPL shall not exceed 300 square feet (27.9 m²) in area and shall be separated by a minimum 4 feet (1219 mm) vertically.~~

Reason:

This proposal makes one change, consistent with the intent of ensuring that all combustible materials on the exterior walls are tested to NFPA 285 and for consistency with other sections of the code. This proposal is intended to address concerns with current language and requirements that could lead to fires like the one in Grenfell Tower (London, England).

The exception for HPL systems up to 50 ft in height to be tested to NFPA 285 is eliminated, consistent with the requirement that all combustibles exceeding 40 ft in height shall be tested. The testing for self-ignition temperature based on ASTM D1929 is not a very robust fire test and is not sufficient to provide assurance of adequate fire performance. The added criteria in the section proposed to be deleted do not ensure that there will be no flame spread upwards or sideways, as would be detected when testing to NFPA 285.

Note: Current IBC definitions:

HIGH-PRESSURE DECORATIVE EXTERIORGRADE COMPACT LAMINATE (HPL).

Panels consisting of layers of cellulose fibrous material impregnated with thermosetting resins and bonded together by a high-pressure process to form a homogeneous nonporous core suitable for exterior use.

HIGH-PRESSURE DECORATIVE EXTERIORGRADE COMPACT LAMINATE (HPL) YSTEM. An exterior wall covering fabricated using HPL in a specific assembly including

This proposal is submitted by the ICC Fire Code Action Committee (FCAC). The FCAC was established by the ICC Board of Directors to pursue opportunities to improve and enhance assigned International Codes with regard to fire safety and hazardous materials in new and existing buildings and facilities and the protection of life and property in wildland urban interface areas. In 2017 the Fire-CAC has held 3 open meetings. In addition, there were numerous conference calls, Regional Work Group and Task Group meetings for the current code development cycle, which included members of the committees as well as any interested parties, to discuss and debate the proposed changes. Related documentation and reports are posted on the FCAC website at: <https://www.iccsafe.org/codes-tech-support/cs/fire-code-action-committee-fcac/>

This proposal is one in a series of related proposals intended to address different technical changes to Chapter 14. While the Fire Code Committee will consider each proposal independently, the intent is for approval of all

proposals in this package which have been submitted as a correlated set of companion code change proposals.

The FCAC analyzed several fatal fires related to exterior façade/curtain wall fires in the development of these new code requirements. The intent of these proposals is to provide a reasonable set of code requirements to ensure fire safety and weather protection for buildings that utilize combustible materials and/or assemblies for the building exterior wall envelope.

1. Grenfell fire, London England:

Buildings Across U.S. Are Wrapped in Same Panels That Fueled Deadly London Fire: <https://www.wsj.com/articles/built-to-burn-thousands-of-buildings-world-wide-are-wrapped-in-combustible-panels-1508858048>

Why	Grenfell	Tower	Burned:	Regulators	Put	Cost	Before	Safety
https://www.nytimes.com/2017/06/24/world/europe/grenfell-tower-london-fire.html								

2. Torch Tower Fire, Dubai

https://en.wikipedia.org/wiki/The_Marina_Torch January 8th, 2018

3. Address Hotel Fire, Dubai https://en.wikipedia.org/wiki/The_Address_Downtown_Dubai January 8th, 2018

Cost Impact

The code change proposal will increase the cost of construction .

The elimination of the current allowances allowing use of HPL to up to 50 on almost all buildings will lead to a more expensive fire-tested product being required for HPL application above 40 feet as fire testing to NFPA 285 will be required.

Internal ID: 397

FS151-18

IBC: 1408.11, 1408.11.1, 1408.11.2, 1408.11.2.1, 1408.11.2.2

Proponent: Marcelo Hirschler, GBH International, representing GBH International (gbhint@aol.com)

2018 International Building Code

Revise as follows:

1408.11 Alternate conditions. HPL and HPL systems shall not be required to comply with Sections 1408.10.1 through 1408.10.4 provided that such systems comply with Section ~~1408.11.1 or 1408.11.2~~ 1408.11.1.

1408.11.1 Installations up to 40 feet in height. HPL shall ~~not be installed more than permitted to be installed up to~~ 40 feet (12 190 mm) in height above grade plane where installed in accordance with Section ~~Section~~ 1408.11.1.1 ~~and or with Section~~ 1408.11.1.2.

1408.11.1.1 Fire separation distance of 5 feet or less. Where the fire separation distance is 5 feet (1524 mm) or less, the area of HPL shall not exceed 10 percent of the *exterior wall* surface.

1408.11.1.2 Fire separation distance greater than 5 feet. Where the fire separation distance is greater than 5 feet (1524 mm), the area of *exterior wall* surface coverage using HPL shall not be limited.

Delete without substitution:

~~**1408.11.2 Installations up to 50 feet in height.** HPL shall not be installed more than 50 feet (15 240 mm) in height above grade plane where installed in accordance with Sections 1408.11.2.1 and 1408.11.2.2.~~

~~**1408.11.2.1 Self-ignition temperature.** HPL shall have a self-ignition temperature of 650°F (343°C) or greater when tested in accordance with ASTM D1929.~~

~~**1408.11.2.2 Limitations.** Sections of HPL shall not exceed 300 square feet (27.9 m²) in area and shall be separated by a minimum 4 feet (1219 mm) vertically.~~

Reason:

This proposal makes a change consistent with the intent of ensuring that all combustible materials on the exterior walls are tested to NFPA 285 and for consistency with other sections of the code. This proposal is Intended to address concerns with current language and requirements that could lead to fires like the one in Grenfell Tower (London, England). The exception for HPL systems up to 50 ft in height that allows them to avoid having to be tested to NFPA 285 is eliminated, consistent with the requirement that all combustibles exceeding 40 ft in height shall be tested. The testing for self ignition temperature based on ASTM D1929 is not a very robust fire test and is not sufficient to provide assurance of adequate fire performance. The added criteria in the section proposed to be deleted do not ensure that there will be no flame spread upwards or sideways, as would be detected when testing to NFPA 285.

This means that all installations above 40 ft in height must be tested to NFPA 285.

Cost Impact

The code change proposal will increase the cost of construction .

The proposal will require that HPL systems used in construction over 40 ft in height must be tested to NFPA 285.

Internal ID: 1170

FS152-18

IBC: 1505.9

Proponent: Jonathan Roberts, UL LLC, representing UL LLC (jonathan.roberts@ul.com)

2018 International Building Code

Revise as follows:

[BF] 1505.9 Rooftop mounted photovoltaic panel systems. Rooftop rack-mounted *photovoltaic panel systems* shall be tested, *listed* and identified with a fire classification in accordance with UL ~~1703~~ and UL-2703. The fire classification shall comply with Table 1505.1 based on the type of construction of the building.

Reason:

Fire classification for rooftop rack-mounted photovoltaic panel systems are determined in accordance with UL 2703.

UL 1703 includes partial fire testing of the photovoltaic panel, which is one of the components of the photovoltaic panel system. UL 2703 uses the results of that component testing, and includes further evaluation and testing of the photovoltaic panel system (i.e. the photovoltaic panel and the rack support system) to establish the Fire Classification for the system. UL 1703 is referenced within UL 2703.

Cost Impact

The code change proposal will not increase or decrease the cost of construction .

Fire classification of these systems are determined in accordance with UL 2703 currently.

Internal ID: 1300

FS153-18

IBC: 202, 905.3.8, 1505.10, 1507.16, 1507.16.1, TABLE 1607.1, 1607.13.3;

IFC: 317, 317.1, 317.2, 317.3, 317.4.3, 504.3, 905.3.8

Proponent: Jonathan Siu, City of Seattle Department of Construction and Inspections, representing Washington Association of Building Officials Technical Code Development Committee (Jon.Siu@seattle.gov)

2018 International Building Code

SECTION 202 DEFINITIONS

Revise as follows:

[BS] LIVE LOAD, ROOF. A load on a roof produced:

1. During maintenance by workers, equipment and materials;
2. During the life of the structure by movable objects such as planters or other similar small decorative appurtenances that are not occupancy related; or
3. By the use and occupancy of the roof such as for ~~roof gardens~~ landscaped roofs or assembly areas.

[F] 905.3.8 ~~Rooftop gardens and landscaped~~ Landscaped roofs. Buildings or structures that have ~~rooftop gardens or landscaped roofs~~ and that are equipped with a standpipe system shall have the standpipe system extended to the roof level on which the ~~rooftop garden or landscaped roof~~ is located.

[BF] 1505.10 ~~Roof gardens and landscaped~~ Landscaped roofs. ~~Roof gardens and landscaped~~ Landscaped roofs shall comply with Section 1505.1 and 1507.16 and shall be installed in accordance with ANSI/SPRI VF-~~1.1~~.

1507.16 Vegetative roofs, ~~roof gardens and landscaped roofs~~. ~~Vegetative roofs, roof gardens and landscaped roofs~~ shall comply with the requirements of this chapter, Section 1607.13.3 and the International Fire Code.

[BF] 1507.16.1 Structural fire resistance. The structural frame and roof construction supporting the load imposed on the roof by the ~~vegetative roof, roof gardens or landscaped roofs~~ shall comply with the requirements of Table ~~601.601~~.

TABLE 1607.1
MINIMUM UNIFORMLY DISTRIBUTED LIVE LOADS, L_0 , AND MINIMUM CONCENTRATED LIVE LOADS g

For SI: 1 inch = 25.4 mm, 1 square inch = 645.16 mm²,

1 square foot = 0.0929 m²,

1 pound per square foot = 0.0479 kN/m², 1 pound = 0.004448 kN,

1 pound per cubic foot = 16 kg/m³.

- a. Floors in garages or portions of buildings used for the storage of motor vehicles shall be designed for the uniformly distributed live loads of this table or the following concentrated loads: (1) for garages restricted to passenger vehicles accommodating not more than nine passengers, 3,000 pounds acting on an area of 4¹/₂ inches by 4¹/₂ inches; (2) for mechanical parking structures without slab or deck that are used for storing passenger vehicles only, 2,250 pounds per wheel.
- b. The loading applies to stack room floors that support nonmobile, double-faced library book stacks, subject to the following limitations:
 1. The nominal book stack unit height shall not exceed 90 inches.
 2. The nominal shelf depth shall not exceed 12 inches for each face.
 3. Parallel rows of double-faced book stacks shall be separated by aisles not less than 36 inches wide.
- c. Design in accordance with ICC 300.
- d. Other uniform loads in accordance with an approved method containing provisions for truck loadings shall be considered where appropriate.
- e. The concentrated wheel load shall be applied on an area of 4.5 inches by 4.5 inches.
- f. The minimum concentrated load on stair treads shall be applied on an area of 2 inches by 2 inches. This load need not be assumed to act concurrently with the uniform load.
- g. Where snow loads occur that are in excess of the design conditions, the structure shall be designed to support the loads due to the increased loads caused by drift buildup or a greater snow design determined by the building official (see Section 1608).
- h. See Section 1604.8.3 for decks attached to exterior walls.
- i. Uninhabitable attics without storage are those where the maximum clear height between the joists and rafters is less than 42 inches, or where there are not two or more adjacent trusses with web configurations capable of accommodating an assumed rectangle 42 inches in height by 24 inches in width, or greater, within the plane of the trusses. This live load need not be assumed to act concurrently with any other live load requirements.
- j. Uninhabitable attics with storage are those where the maximum clear height between the joists and rafters is 42 inches or greater, or where there are two or more adjacent trusses with web configurations capable of accommodating an assumed rectangle 42 inches in height by 24 inches in width, or greater, within the plane of the trusses.

The live load need only be applied to those portions of the joists or truss bottom chords where both of the following conditions are met:

- i. The attic area is accessible from an opening not less than 20 inches in width by 30 inches in length that is located where the clear height in the attic is not less than 30 inches.
- ii. The slopes of the joists or truss bottom chords are not greater than two units vertical in 12 units horizontal.

The remaining portions of the joists or truss bottom chords shall be designed for a uniformly distributed concurrent live load of not less than 10 pounds per square foot.

- k. Attic spaces served by stairways other than the pull-down type shall be designed to support the minimum live load specified for habitable attics and sleeping rooms.
- l. Areas of occupiable roofs, other than ~~roof gardens~~ landscaped roofs and assembly areas, shall be designed for appropriate loads as approved by the building official. Unoccupied landscaped areas of roofs shall be designed in accordance with Section 1607.13.3.
- m. Live load reduction is not permitted.
- n. Live load reduction is only permitted in accordance with Section 1607.11.1.2 or Item 1 of Section 1607.11.2.
- o. Live load reduction is only permitted in accordance with Section 1607.11.1.3 or Item 2 of Section

1607.13.3 Occupiable roofs. Areas of roofs that are occupiable, such as *vegetative roofs*, ~~roof gardens~~ landscaped roofs or for assembly or other similar purposes, and marquees are permitted to have their uniformly distributed live loads reduced in accordance with Section 1607.11.

2018 International Fire Code

Revise as follows:

~~SECTION 317 ROOFTOP GARDENS AND LANDSCAPED ROOFS~~

317.1 General. ~~Rooftop gardens and landscaped~~ Landscaped roofs shall be installed and maintained in accordance with Sections 317.2 through 317.5 and Sections 1505 and 1507.16 of the International Building Code.

317.2 Rooftop garden or landscaped Landscaped roof size. ~~Rooftop garden or landscaped~~ Landscaped roof areas shall not exceed 15,625 square feet (1450 m²) in size for any single area with a maximum dimension of 125 feet (39 m) in length or width. A minimum 6-foot-wide (1.8 m) clearance consisting of a Class A-rated roof system complying with ASTM E108 or UL 790 shall be provided between adjacent ~~rooftop gardens or landscaped~~ roof areas.

317.3 Rooftop structure and equipment clearance. For all ~~vegetated roofing systems~~ vegetative roofs abutting combustible vertical surfaces, a Class A-rated roof system complying with ASTM E108 or UL 790 shall be achieved for a minimum 6-foot-wide (1829 mm) continuous border placed around rooftop structures and all rooftop equipment including, but not limited to, mechanical and machine rooms, penthouses, skylights, roof vents, solar panels, antenna supports and building service equipment.

317.4.3 Maintenance plan. The *fire code official* is authorized to require a maintenance plan for vegetation placed on roofs due to the size of a landscaped roof garden, materials used or where a fire hazard exists to the building or exposures due to the lack of maintenance.

504.3 Stairway access to roof. New buildings four or more stories above grade plane, except those with a roof slope greater than four units vertical in 12 units horizontal (33.3-percent slope), shall be provided with a *stairway* to the roof. *Stairway* access to the roof shall be in accordance with Section 1011.12. Such *stairway* shall be marked at street and floor levels with a sign indicating that the *stairway* continues to the roof. Where roofs are used for ~~roof gardens~~ landscaped roofs or for other purposes, *stairways* shall be provided as required for such occupancy classification.

905.3.8 Rooftop gardens and landscaped Landscaped roofs. Buildings or structures that have ~~rooftop gardens or landscaped~~ roofs and that are equipped with a standpipe system shall have the standpipe system extended to the roof level on which the ~~rooftop garden or landscaped~~ roof is located.

Reason:

This proposal is purely editorial, aligning terms and replacing two undefined terms with one.

While "vegetative roof" is a defined term (essentially part of the building envelope) the I-codes usually, but not always, use the undefined terms "roof garden" and "landscaped roofs" in conjunction with each other ("roof gardens and landscaped roofs"). Occasionally, they appear in conjunction with "vegetative roof." Based on the context of use, it appears the accepted concept is roof gardens and landscaped roofs are not part of the building envelope--they do not contribute to the waterproofing of the building--but instead are plantings that are placed on top of the roof system. Since neither term is defined, this code change simply chooses "landscaped roof" over "roof garden," as we think landscaping is the more generic term.

We believe we have correctly identified every place this change is necessary across the I-codes, based on word searches for forms of "vegetative," "landscape," and "garden," but this proposal only addresses changes to be made in the Group A codes. We are planning to submit a separate code change proposal to coordinate the terms in the IECC in Group B. Note the terms appear in IBC Section 1607.13.3.1 and IECC Section CA103, but these are not being changed, as none was necessary.

The other editorial change is in IFC 317.3, where "vegetated roofing system" is replaced with the defined term, "vegetative roof."

If direction is given by the Committee, we would be willing to submit a proposal for consideration by the Admin Committee in Group B that would define "landscaped roof," but we have chosen not to at this time in order to preserve the editorial nature of the proposal.

Cost Impact

The code change proposal will not increase or decrease the cost of construction .

Because this proposal is purely editorial, there is no cost impact.

Internal ID: 242

FS154-18

IBC: 1509, 1509.1, 1509.2, 1509.3, 1509.4

Proponent: Jason Wilen AIA CDT RRO, National Roofing Contractors Association (NRCA), representing National Roofing Contractors Association (NRCA) (jwilen@nrca.net)

2018 International Building Code

Delete without substitution:

~~SECTION 1509 RADIANT BARRIERS INSTALLED ABOVE DECK~~

~~**[BF] 1509.1 General.** A *radiant barrier* installed above a deck shall comply with Sections 1509.2 through 1509.4.~~

~~**[BF] 1509.2 Fire testing.** *Radiant barriers* shall be permitted for use above decks where the *radiant barrier* is covered with an *approved* roof covering and the system consisting of the *radiant barrier* and the roof covering complies with the requirements of either FM 4450 or UL 1256.~~

~~**[BF] 1509.3 Installation.** The low emittance surface of the *radiant barrier* shall face the continuous airspace between the *radiant barrier* and the roof covering.~~

~~**[BF] 1509.4 Material standards.** A *radiant barrier* installed above a deck shall comply with ASTM C1313/1313M.~~

Reason:

The radiant barriers section was added to the 2015 edition of IBC based on a proposal from the Reflective Insulation Manufacturer Association (RIMA). After receiving a number of questions from contractors; especially about the installation requirements in section 1509.3, NRCA contacted RIMA in an effort understand the intent of their original code proposal. As part of those discussions it was agreed that Section 1509 should be removed, and revised text will be submitted by RIMA to relocate and clarify radiant barrier provisions to IBC Section 1507.3—Clay and Concrete Tile as the above-roof deck application of the material is intended to be used exclusively with this roof covering.

Cost Impact

The code change proposal will not increase or decrease the cost of construction .

The proposed change does not increase the stringency of the code.

Internal ID: 1199

FS155-18

IBC: 202 (New), 2603.1.1 (New), Chapter 35, ordinal

Proponent: Brian Tollisen, representing ICC Foam Plastic Insulation Standard Committee (Brian.Tollisen@dos.ny.gov)

2018 International Building Code

Add new definition as follows:

SPRAY-APPLIED FOAM PLASTIC. Single- and multi-component, spray-applied foam plastic insulation used in nonstructural applications which are installed at locations wherein the material is applied in a liquid or frothed state, permitted to free rise and cure in situ.

Add new text as follows:

2603.1.1 Spray-applied foam plastic. Single- and multiple-component spray-applied foam plastic insulation shall comply with the provisions of Section 2603 and ICC 1100-2018.

Add new standard(s) follows:

CHAPTER 35 REFERENCED STANDARDS

ICC

International Code Council, Inc.
500 New Jersey Ave NW 6th Floor
Washington DC 20001

1100-2018:

Standard for Spray-applied Foam Plastic Insulation

Reason:

The IBC contains requirements for thermal resistance of insulating materials but currently includes limited material standards for certain types of insulating materials. The purpose of this proposal is to introduce a performance standard for spray-applied foam plastic insulation. The standard establishes the minimum physical and performance properties as well as application requirements for spray-applied foam plastic insulations. This standard will benefit Code officials, spray-applied foam plastic insulation manufacturers, design professionals, product testing and certification agencies.

Cost Impact

The code change proposal will not increase or decrease the cost of construction .

This proposal simply adds a material performance standard to the code that reflects the current industry and construction practices.

Analysis: A review of the standard proposed for inclusion in the code, ICC 1100-2018, with regard to the ICC criteria for referenced standards (Section 3.6 of CP#28) will be posted on the ICC website on or before April 2, 2018.

Internal ID: 1347

FS156-18

IBC: 2603.4.1.5

Proponent: Bill McHugh, The McHugh Company, representing Chicago Roofing Contractors Association (Bill@mc-hugh.us)

2018 International Building Code

Revise as follows:

2603.4.1.5 Roofing. A thermal barrier is not required for foam plastic insulation that is a part of a Class A, B or C roof-covering assembly that is installed in accordance with the code and the manufacturer's instructions and is either constructed as described in Item 1 or tested as described in Item 2.

1. The roof assembly is separated from the interior of the building by an approved thermal barrier of 1/2" gypsum board or a material that is tested in accordance with and meets the acceptance criteria of both the Temperature Transmission Fire Test and the Interior Test of NFPA 275 and wood structural panel sheathing not less than 0.47 inch (11.9 mm) in thickness bonded with exterior glue, with edges supported by blocking, tongue-and-groove joints, other approved type of edge support or an equivalent material.
2. The assembly with the foam plastic insulation satisfactorily passes NFPA 276 or UL 1256.

Reason:

In Chapter 26 of the International Building Code, the addition of either a 1/2" gypsum board or materials that would also comply based on testing should be allowed. This provides equal opportunity for all types of materials to protect foam roofing insulation from fire.

Cost Impact

The code change proposal will increase the cost of construction .

This proposal will increase the cost of construction by about \$1.00 - \$1.25US per square foot of roof area.

Internal ID: 1734

FS157-18

IBC: 2603.5, 2603.5.1, 2603.5.2, 2603.5.3, 2603.5.4, 2603.5.5, 2603.5.6, 2603.5.7, 2603.5 (New), 2603.5.1 (New), 2603.5.2 (New), 2603.5.2.1 (New), 2603.5.3 (New), 2603.5.4 (New), 2603.5.4.1 (New), 2603.5.4.2 (New), 2603.5.4.3 (New), 2603.5.5 (New), 2603.5.5.1 (New), 2603.5.5.2 (New), 2603.5.5.3 (New), 2603.5.5.4 (New)

Proponent: John Woestman, Kellen Co., representing Extruded Polystyrene Foam Association (XPSA) (jwoestman@kellencompany.com)

2018 International Building Code

Delete and substitute as follows:

~~**2603.5 Exterior walls of buildings of any height.** Exterior walls of buildings of Type I, II, III or IV construction of any height shall comply with Sections 2603.5.1 through 2603.5.7. Exterior walls of cold storage buildings required to be constructed of noncombustible materials, where the building is more than one story in height, shall comply with the provisions of Sections 2603.5.1 through 2603.5.7. Exterior walls of buildings of Type V construction shall comply with Sections 2603.2, 2603.3 and 2603.4. Fireblocking shall be in accordance with Section 718.2.~~

2603.5 Exterior walls of buildings of any height.

Exterior walls of buildings of Type I, II, III or IV construction of any height shall comply with Sections 2603.5.1 through 2603.5.7. Exterior walls of cold storage buildings required to be constructed of noncombustible materials, where the building is more than one story in height, shall comply with the provisions of Sections 2603.5.1 through 2603.5.7. Exterior walls of buildings of Type V construction shall comply with Sections 2603.2, 2603.3 and 2603.4. Fireblocking shall be in accordance with Section 718.2.

Delete without substitution:

~~**2603.5.1 Fire-resistance-rated walls.** Where the wall is required to have a fire-resistance rating, data based on tests conducted in accordance with ASTM E119 or UL 263 shall be provided to substantiate that the fire-resistance rating is maintained.~~

~~**2603.5.2 Thermal barrier.** Any foam plastic insulation shall be separated from the building interior by a thermal barrier meeting the provisions of Section 2603.4, unless special approval is obtained on the basis of Section 2603.9.~~

~~**Exception:** One-story buildings complying with Section 2603.4.1.4.~~

~~**2603.5.3 Potential heat.** The potential heat of foam plastic insulation in any portion of the wall or panel shall not exceed the potential heat expressed in Btu per square foot (mj/m^2) of the foam plastic insulation contained in the wall assembly tested in accordance with Section 2603.5.5. The potential heat of the foam plastic insulation shall be determined by tests conducted in accordance with NFPA 259 and the results shall be expressed in Btu per square foot (mj/m^2).~~

~~**Exception:** One-story buildings complying with Section 2603.4.1.4.~~

~~**2603.5.4 Flame spread and smoke-developed indices.** Foam plastic insulation, exterior coatings and facings shall be tested separately in the thickness intended for use, but not to exceed 4 inches (102 mm), and shall each have a flame spread index of 25 or less and a smoke-developed index of 450 or less as determined in accordance with ASTM E84 or UL 723.~~

~~**Exception:** Prefabricated or factory-manufactured panels having minimum 0.020-inch (0.51 mm) aluminum facings and a total thickness of $\frac{1}{4}$ -inch (6.4 mm) or less are permitted to be tested as an assembly where the foam plastic core is not exposed in the course of construction.~~

~~**2603.5.5 Vertical and lateral fire propagation.** The exterior wall assembly shall be tested in accordance with and comply with the acceptance criteria of NFPA 285.~~

~~Exceptions:~~

- ~~1. One-story buildings complying with Section 2603.4.1.4.~~
- ~~2. Wall assemblies where the foam plastic insulation is covered on each face by not less than 1-inch (25 mm) thickness of masonry or concrete and meeting one of the following:~~
 - ~~2.1. There is no airspace between the insulation and the concrete or masonry.~~
 - ~~2.2. The insulation has a flame spread index of not more than 25 as determined in accordance with ASTM E84 or UL 723 and the maximum airspace between the insulation~~

and the concrete or masonry is not more than 1 inch (25 mm).

2603.5.6 Label required. The edge or face of each piece, package or container of foam plastic insulation shall bear the label of an approved agency. The label shall contain the manufacturer's or distributor's identification, model number, serial number or definitive information describing the product or materials' performance characteristics and approved agency's identification.

2603.5.7 Ignition. Exterior walls shall not exhibit sustained flaming where tested in accordance with NFPA 268. Where a material is intended to be installed in more than one thickness, tests of the minimum and maximum thickness intended for use shall be performed.

Exception: Assemblies protected on the outside with one of the following:

1. A thermal barrier complying with Section 2603.4.
2. A minimum 1-inch (25 mm) thickness of concrete or masonry.
3. Glass fiber reinforced concrete panels of a minimum thickness of $\frac{3}{8}$ inch (9.5 mm).
4. Metal faced panels having minimum 0.019 inch thick (0.48 mm) aluminum or 0.016 inch thick (0.41 mm) corrosion resistant steel outer facings.
5. A minimum $\frac{7}{8}$ inch (22.2 mm) thickness of stucco complying with Section 2510.
6. A minimum $\frac{3}{4}$ inch (6.4 mm) thickness of fiber cement lap, panel or shingle siding complying with Section 1404.16 and Section 1404.16.1 or 1404.16.2.

Add new text as follows:

2603.5 Exterior walls containing foam plastic insulation. Exterior walls containing foam plastic insulation shall comply with Section 2603.5.1, or Section 2603.5.2 or Section 2603.5.3. Fireblocking shall be in accordance with Section 718.2.

2603.5.1 Buildings of Type I, II, III or IV construction of any height. Exterior wall assemblies with foam plastic insulation of buildings of Type I, II, III or IV construction of any height shall comply with Section 2603.5.4. The foam plastic insulation component shall comply with Section 2603.5.5.

2603.5.2 Exterior walls of buildings of Type V construction of any height. Foam plastic insulation used in exterior walls of buildings of Type V construction shall comply with Sections 2603.2, 2603.3 and 2603.4.

2603.5.2.1 Fire-resistance-rated walls. Where the exterior wall is required to have a fire-resistance rating, data based on tests conducted in accordance with ASTM E119 or UL 263 shall be provided to substantiate that the fire-resistance rating is maintained.

2603.5.3 Cold storage buildings of noncombustible materials more than one story in height. Exterior wall assemblies containing foam plastic insulation on cold storage buildings required to be constructed of noncombustible materials, where the building is more than one story in height, shall comply with Section 2603.5.4. The foam plastic insulation component shall comply with Section 2603.5.5.

2603.5.4 Exterior wall test requirements. Where exterior walls of buildings are required to comply with Sections 2603.5.1 or 2603.5.3, the wall assembly shall comply with Sections 2603.5.4.1 through 2603.5.4.3.

2603.5.4.1 Fire-resistance-rated walls. Where the exterior wall is required to have a fire-resistance rating, data based on tests conducted in accordance with ASTM E119 or UL 263 shall be provided to substantiate that the fire-resistance rating is maintained.

2603.5.4.2 Vertical and lateral fire propagation. The exterior wall assembly shall be tested in accordance with and comply with the acceptance criteria of NFPA 285.

Exceptions:

1. One-story buildings complying with Section 2603.4.1.4.
2. Wall assemblies where the foam plastic insulation is covered on each face by not less than 1-inch (25 mm) thickness of masonry or concrete and meeting one of the following:
 - 2.1. There is no airspace between the insulation and the concrete or masonry.
 - 2.2. The foam plastic insulation has a flame spread index of not more than 25 as determined

in accordance with ASTM E84 or UL 723 and the maximum airspace between the insulation and the concrete or masonry is not more than 1 inch (25 mm).

2603.5.4.3 Ignition. The exterior wall assembly shall not exhibit sustained flaming where tested in accordance with NFPA 268. Where the foam plastic insulation is intended to be installed in more than one thickness, tests of the minimum and maximum thickness intended for use shall be performed.

Exceptions:

1. A thermal barrier complying with Section 2603.4.
2. A minimum 1-inch (25 mm) thickness of concrete or masonry.
3. Glass-fiber-reinforced concrete panels of a minimum thickness of 3/8 inch (9.5 mm).
4. Metal-faced panels having minimum 0.019-inch-thick (0.48 mm) aluminum or 0.016-inch-thick (0.41 mm) corrosion-resistant steel outer facings.
5. A minimum 7/8-inch (22.2 mm) thickness of stucco complying with Section 2510.
6. A minimum 1/4-inch (6.4 mm) thickness of fiber-cement lap, panel or shingle siding complying with Section 1404.16 and Section 1404.16.1 or 1404.16.2.

2603.5.5 Foam plastic insulation used in exterior walls. Where exterior walls of buildings are required to comply with Sections 2603.5.1 or 2603.5.3, the foam plastic insulation component shall comply with Sections 2603.5.5.1 through 2603.5.5.4.

2603.5.5.1 Thermal barrier. Any foam plastic insulation shall be separated from the building interior by a thermal barrier meeting the provisions of Section 2603.4, unless special approval is obtained on the basis of Section 2603.9.

Exception: One-story buildings complying with Section 2603.4.1.4...

2603.5.5.2 Potential heat. The potential heat of foam plastic insulation in any portion of the wall or panel shall not exceed the potential heat expressed in Btu per square feet (mj/m^2) of the foam plastic insulation contained in the wall assembly tested in accordance with Section 2603.5.4.2. The potential heat of the foam plastic insulation shall be determined by tests conducted in accordance with NFPA 259 and the results shall be expressed in Btu per square feet (mj/m^2).

Exception: One-story buildings complying with Section 2603.4.1.4.

2603.5.5.3 Flame spread and smoke-developed indices. Foam plastic insulation, and exterior coatings and facings shall be tested separately in the thickness intended for use, but not to exceed 4 inches (102 mm), and each shall have a flame spread index of 25 or less and a smoke-developed index of 450 or less as determined in accordance with ASTM E84 or UL 723.

Exception: Prefabricated or factory-manufactured panels having minimum 0.020-inch (0.51 mm) aluminum facings and a total thickness of 1/4 inch (6.4 mm) or less are permitted to be tested as an assembly where the foam plastic core is not exposed in the course of construction.

2603.5.5.4 Label required. The edge or face of each piece, package or container of foam plastic insulation shall bear the label of an approved agency. The label shall contain the manufacturer's or distributor's identification, model number, serial number or definitive information describing the product or materials' performance characteristics and approved agency's identification.

Reason:

With recent fire incidents, there has been increased attention on the fire performance of exterior walls containing combustible materials, such as foam plastic insulation. The 2018 IBC charging section, Section 2603.5, contains 3 different exterior walls, each with separate requirements, causing misunderstanding. Furthermore, sections related to requirements for the foam plastic component of the exterior wall are sprinkled throughout the section, causing additional confusion. This code change is a reorganization of the exterior wall section. No technical changes are included.

Separate sections are provided for

1. Exterior walls of Type I, II, III, IV construction of buildings of **any** height; (Note that the exception for one story buildings **applies only to those specifically described in Section 2603.4.1.4**)

2. Exterior walls of buildings of Type V construction has the appropriate pointers to the foam insulation requirements.
3. Exterior walls of cold storage buildings of noncombustible construction and more than one story in height;

Exterior wall assembly tests for exterior walls of Type I, II, III, IV construction of buildings of **any** height and exterior walls of cold storage buildings of noncombustible construction and more than one story in height are consolidated in Section 2603.5.4. Similarly, all testing requirements for the foam plastic insulation components for these building types are listed in Section 2603.5.5.

Cost Impact

The code change proposal will not increase or decrease the cost of construction .

No technical changes are intended to be included in this proposal.

Internal ID: 2341

FS158-18

IBC: 2606.7.4, Chapter 35, 35

Proponent: Jonathan Roberts, UL LLC, representing UL LLC (jonathan.roberts@ul.com)

2018 International Building Code

Revise as follows:

2606.7.4 Fire suppression system. In buildings that are equipped throughout with an *automatic sprinkler system* in accordance with Section 903.3.1.1, plastic light-diffusing systems shall be protected both above and below unless the sprinkler system has been specifically approved for installation only above the light-diffusing ~~system.~~system, or the light-diffusing system is listed and labeled in accordance with UL 723S. Areas of light-diffusing systems that are protected in accordance with this section shall not be limited.

Add new standard(s) follows:

CHAPTER 35 REFERENCED STANDARDS

UL

UL LLC
333 Pfingsten Road
Northbrook IL 60062-2096

723S-2006:

Drop-Out Ceilings Installed Beneath Automatic Sprinklers

Reason:

Section 2606.7.4 currently states plastic light-diffusing systems shall be protected both above and below unless the sprinkler system has been specifically approved for installation only above the light-diffusing system. This language places the burden for approving a system on the code official without providing any guidance on which to make that decision. This proposal is intended to provide the option of using a science based method for approving a drop-out light diffusing ceiling system listed and labeled for use beneath sprinkler systems.

Cost Impact

The code change proposal will not increase or decrease the cost of construction .

The use of a drop-out ceiling system listed and labeled to UL 723S is being offered as an option to the use of a specifically approved sprinkler system already permitted in this Section. In addition, although UL 723S is not currently specified in the code, such listings have been used for years to approve drop-out ceiling systems. As such, this proposal does not mandate any change in construction practices.

Analysis: A review of the standard proposed for inclusion in the code, UL 723S-2006, with regard to the ICC criteria for referenced standards (Section 3.6 of CP#28) will be posted on the ICC website on or before April 2, 2018.

Internal ID: 375

FS159-18

IBC: 2607.3, 2607.5

Proponent: Michael O'Brian, Chair, representing FCAC (FCAC@iccsafe.org)

2018 International Building Code

Revise as follows:

2607.3 Height limitation. Light-transmitting plastics shall not be installed more than 75 feet (22 860 mm) above *grade plane*, ~~except as allowed by Section 2607.5.~~

2607.5 Automatic sprinkler system. Where the building is equipped throughout with an *automatic sprinkler system* in accordance with Section 903.3.1.1, the maximum percentage area of *exterior wall* in any *story* in light-transmitting plastic wall panels and the maximum square footage of a single area given in Table 2607.4 shall be increased 100 percent, but the area of light-transmitting plastic wall panels shall not exceed 50 percent of the wall area in any story, or the area permitted by Section 705.8 for unprotected openings, whichever is smaller. These installations shall ~~be exempt from height limitations~~ not be installed more than 75 feet (22 860 mm) above grade plane.

Reason:

This proposal eliminates the permission for light transmitting wall panels to be installed in unlimited heights when the building is protected by sprinklers. This is consistent with the proposed change for MCMs in chapter 14. There should be no allowance to use light transmitting wall panels in unlimited heights simply because of sprinkler exceptions, since sprinklers do not control outside fires.

According to an NFPA study published in 2014 (Fire Hazards of Exterior Wall Assemblies Containing Combustible Components), slightly more than half of the exterior facade fires originated from interior ignition. Sprinklers will help restrict an interior fire from reaching the exterior facade, but will have limited effect on exterior ignition or fire spread across combustible assemblies.

Also keep in mind that when these fires occur, occupants have little choice but to evacuate and stairs are not designed for full building evacuation. It can be expected that evacuating occupants will encounter stairs overflowing with other evacuating occupants. As observed during the 63 story Address Hotel fire in Dubai on New Year's Eve 2015, these situations increase the tendency to panic and cause crushes. In addition, most stair pressurization systems take outside air from the roof, which can be expected to bring in contaminated air, decreasing the level of comfort for evacuating occupants. And, those aren't even the worst scenarios. When occupants evacuate stair enclosures at grade, they are greeted with flaming debris raining down on them.

This proposal is submitted by the ICC Fire Code Action Committee (FCAC). The FCAC was established by the ICC Board of Directors to pursue opportunities to improve and enhance assigned International Codes with regard to fire safety and hazardous materials in new and existing buildings and facilities and the protection of life and property in wildland urban interface areas. In 2017 the Fire-CAC has held 3 open meetings. In addition, there were numerous conference calls, Regional Work Group and Task Group meetings for the current code development cycle, which included members of the committees as well as any interested parties, to discuss and debate the proposed changes. Related documentation and reports are posted on the FCAC website at: <https://www.iccsafe.org/codes-tech-support/cs/fire-code-action-committee-fcac/>

This proposal is one in a series of related proposals intended to address different technical changes to Chapter 14. While the Fire Code Committee will consider each proposal independently, the intent is for approval of all proposals in this package which have been submitted as a correlated set of companion code change proposals.

The FCAC analyzed several fatal fires related to exterior façade/curtain wall fires in the development of these new code requirements. The intent of these proposals is to provide a reasonable set of code requirements to ensure fire safety and weather protection for buildings that utilize combustible materials and/or assemblies for the building exterior wall envelope.

1. Grenfell fire, London England:

Buildings Across U.S. Are Wrapped in Same Panels That Fueled Deadly London Fire: <https://www.wsj.com/articles/built-to-burn-thousands-of-buildings-world-wide-are-wrapped-in-combustible-panels-1508858048>

Why	Grenfell	Tower	Burned:	Regulators	Put	Cost	Before	Safety

<https://www.nytimes.com/2017/06/24/world/europe/grenfell-tower-london-fire.html>

2. Torch Tower Fire, Dubai

https://en.wikipedia.org/wiki/The_Marina_Torch January 8th, 2018

3. Address Hotel Fire, Dubai https://en.wikipedia.org/wiki/The_Address_Downtown_Dubai January 8th, 2018

Cost Impact

The code change proposal will increase the cost of construction .

The elimination of the current allowances allowing use of light transmitting plastics above 75 on almost all buildings which are equipped with fire sprinklers will lead to a more expensive fire-tested product being required for application above 40 feet.

Internal ID: 398

FS160-18

IBC: 2610.1, 2610.1.1 (New)

Proponent: Mike Fischer, Kellen Company, representing The Plastic Glazing Coalition of the American Chemistry Council (mfischer@kellencompany.com)

2018 International Building Code

Revise as follows:

2610.1 Light-transmitting plastic glazing of skylight assemblies. Skylight assemblies glazed with light-transmitting plastic shall conform to the provisions of this section and Section 2606. ~~Unit skylights glazed with light-transmitting plastic shall comply with Section 2405.5.~~

Exception: Skylights in which the light-transmitting plastic conforms to the required roof-covering class in accordance with Section 1505.

Add new text as follows:

2610.1.1 Unit skylights. Unit skylights glazed with light-transmitting plastic shall comply with Section 2405.5.

Reason:

One of the problems with exceptions to code requirements is they are often unclear. In Section 2610.1, the code contains three provisions for light-transmitting plastics in skylights - compliance with Sections 2606, 2610, and 2405.5.

The exception covers skylights that meet the roof covering classifications in Section 1505 but fails to say exactly which provisions the skylights are exempted from. Is it Section 2405.5? Would a Class A Fire rating exempt the skylight from requirements? We think not.

It seems obvious that the intent of the code is not to exempt unit skylights from the requirements found in Section 2405.5. This proposal makes that important distinction. Furthermore, the intent was also to allow materials that can meet the roof assembly fire classification requirements to avoid additional testing that is redundant to the classification testing. Code officials should not have to study the code to infer what simple code language can easily state.

Cost Impact

The code change proposal will not increase or decrease the cost of construction .

The proposal is editorial in nature and makes no technical changes to the code.

Internal ID: 2047

FS161-18

IBC: 2613.2

Proponent: Jonathan Roberts, UL LLC, representing UL LLC (jonathan.roberts@ul.com)

2018 International Building Code

Revise as follows:

2613.2 Labeling and identification. Fiber-reinforced polymers shall be listed. Packages and containers of *fiber-reinforced polymer* and their components ~~delivered to the job site~~ shall bear the label of an approved agency showing the manufacturer's name, product listing, product identification and information sufficient to determine that the end use will comply with the code requirements.

Reason:

This proposal is intended to clarify these products shall be both listed and labeled. This terminology is consistent with the definitions of these terms and their use in numerous other Sections of the code.

Cost Impact

The code change proposal will not increase or decrease the cost of construction .

The changes are editorial and do not change construction requirements.

Internal ID: 376

2018 GROUP A – PROPOSED CHANGES TO THE INTERNATIONAL BUILDING CODE – GENERAL

GENERAL CODE COMMITTEE

Gary Lewis, Chair
Chief Inspector
City of Summit
Summitt, NJ

Steven L. McDaniel, CPCA, Vice Chair
Building Official
City of Corning
Corning, NY

Matt Belcher
Rep: National Association of Home Builders
Principal
Verdatek Solutions LLC
Wildwood, MO

Brian Bishop, CBO
Deputy Building Official
City of Des Moines
Des Moines, IA

Amy T. Carpenter, AIA
Senior Designer/Project Manager-Vice President
SFCS Architects
Blue Bell, PA

John Catlett, MCP
Director of Codes & Standards
BOMA International
Washington, DC

Jenifer Gilliland, MPA
Code Development Analyst
City of Seattle
Seattle, WA

Raymond A. Grill, PE, LEED AP
Principal
Arup
Washington, DC

Ron E. Hampton, MCP, CBO
Field Inspector II
KY Department of Housing, Building & Const.
Div. Building Code Enforcement
Catlettsburg, KY

Eirene Knott, MCP, CBO, CFM
Director of Code Services
BRR Architecture
Merriam, KS

Thomas Pitchford, CBO
Chief Building Official
Greenwood, Village, CO

Michael Pokorny, PE
Firefighter/Rescuer III
Montgomery County Fire & Rescue Service
Aspen Hill, MD

Michael Shannon, PE, CBO
Development Services Director-Building Official
City of San Antonio, Development Services
Department
San Antonio, TX

Steven R. Winkel, FAIA, PE, CASp
Rep: The American Institute of Architects
Partner, West Coast Office Manager
The Preview Group, Inc.
Berkeley, CA

James M. Williams, AIA, PE, CE, SE, LEED AP
President
AE URBIA
South Jordan, UT

Staff Secretariat

Kermit Robinson
Senior Technical Staff
International Code Council
Western Regional Office
Brea, CA

Allan Bilka, RA
Senior Staff Architect
International Code Council
Central Regional Office
Country Club Hills, IL

TENTATIVE ORDER OF DISCUSSION 2018 PROPOSED CHANGES TO THE INTERNATIONAL BUILDING CODE – GENERAL

The following is the tentative order in which the proposed changes to the code will be discussed at the public hearings. Proposed changes which impact the same subject have been grouped to permit consideration in consecutive changes.

Proposed change numbers that are indented are those which are being heard out of numerical order. Indentation does not necessarily indicate that one change is related to another. Proposed changes may be grouped for purposes of discussion at the hearing at the discretion of the chair. Note that some G code change proposals may not be included on this list, as they are being heard by another committee.

G9-18	G64-18	G80-18	S12-18
G13-18	G65-18	G84-18	S13-18
G14-18	G66-18	G89-18	G137-18
G15-18 Part I	G68-18	FS5-18	G138-18
G8-18	G71-18 Part I	FS6-18	G139-18
G16-18	G72-18	FS73-18	G140-18
G17-18	G73-18	FS81-18	G141-18
G18-18	G74-18	G146-18	G143-18
G21-18	G76-18	G152-18	G142-18
G22-18	G77-18	G109-18	G144-18
G23-18 Part I	G78-18	G110-18	G145-18
G24-18	G79-18	G111-18	G147-18
G25-18	G81-18	G112-18	G148-18
G1-18	G82-18	G113-18	G149-18
G2-18	G83-18	G114-18	G150-18
G30-18	G85-18	G115-18	G151-18
G32-18	G86-18	G116-18 Part I	F262-18 Part II
G33-18	G87-18	G117-18	F267-18 Part II
G36-18	G88-18	G118-18	G153-18
G37-18	G90-18	G119-18	G154-18
G39-18	G93-18	G120-18	
G40-18	G94-18	M15-18 Part II	
G41-18	G95-18	G121-18	
G42-18	G96-18	G122-18	
G46-18	G97-18	G123-18	
G47-18	G98-18	G124-18	
G48-18	G99-18	G125-18	
G53-18	G100-18	G126-18	
G54-18	G101-18	G127-18	
G55-18	G102-18	G128-18	
G56-18	G103-18	G129-18	
G57-18	G104-18	G130-18 Part I	
G58-18	G105-18	G131-18	
G59-18	G106-18	G133-18	
G60-18	G107-18	G135-18	
G61-18	G108-18	G136-18	
G62-18	G27-18	S10-18	
G63-18	G75-18	S11-18	

G1-18

IBC: SECTION 202, 202

Proponent: Stephen Thomas, Colorado Code Consulting, LLC, representing Colorado Chapter ICC (stthomas@coloradocode.net)

2018 International Building Code

SECTION 202 DEFINITIONS

Revise as follows:

[BG] ATRIUM. An opening connecting two or more stories other than ~~enclosed stairways~~ interior exit stairways or ramps, exit access stairways or ramps, elevators, hoistways, escalators, plumbing, electrical, air-conditioning or other equipment, which is closed at the top and not defined as a mall. Stories, as used in this definition, do not include balconies within assembly groups or mezzanines that comply with Section 505.

Reason:

The terms "interior exit stairways or ramps" and "exit access stairway or ramps" referenced in Chapter 10 were added in the 2012 and 2015 IBC. However, they were not referenced in the Atrium definition. This change is only intended to clean up the language and provide consistency within the code. It may be considered to be editorial.

Cost Impact

The code change proposal will not increase or decrease the cost of construction .

The change is editorial in nature. Therefore, there is no cost implication.

Internal ID: 210

G2-18

IBC: SECTION 202, 202

Proponent: Gregory Keith, representing The Boeing Company (grkeith@mac.com)

2018 International Building Code

SECTION 202 DEFINITIONS

Revise as follows:

[BG] ATRIUM. An opening connecting two or more stories ~~other than enclosed stairways, elevators, hoistways, escalators, plumbing, electrical, air conditioning or other equipment, which is closed at the top and not defined as a mall. Stories other than those vertical openings listed at Sections 712.1.1 through 712.1.6 and Sections 712.1.8 through 712.1.14.~~ Stories, as used in this definition, do not include balconies within assembly ~~groups~~ occupancies or mezzanines that comply with Section 505.

Reason:

The current definition of ATRIUM can be confusing. It describes in simple terms what an atrium is. In an apparent attempt to provide clarification it also provides a partial list of what an atrium is not. Included in the list were enclosed stairways. Enclosed stairways could include both interior exit stairways and enclosed exit access stairways. Appropriate reference to unenclosed exit access stairways is not made. In any event, the other vertical openings list is incomplete. The present incomplete "laundry list" has been replaced with specific reference to all other applicable vertical openings listed at Section 712.1.

Fundamentally, vertical openings serve one of three purposes: utility, means of egress or architectural. This distinction is made within the proposed definition.

Additionally, an editorial correction was made to the ultimate sentence by changing assembly groups to assembly occupancies.

Approval of this proposal will provide clarification as to what constitutes an atrium for the benefit of code users.

Cost Impact

The code change proposal will not increase or decrease the cost of construction .

This proposal is essentially editorial in nature.

Internal ID: 1547

G3-18

IBC: SECTION 202, 202 (New)

Proponent: Amanda Hickman, representing RIMA International (amanda@thehickmangroup.com)

THIS CODE CHANGE WILL BE HEARD BY THE IBC FIRE SAFETY COMMITTEE. SEE THE TENTATIVE HEARING ORDER FOR THIS COMMITTEE.

2018 International Building Code

SECTION 202 DEFINITIONS

Add new definition as follows:

EMITTANCE The ratio of radiant heat flux emitted by a specimen to that emitted by a blackbody at the same temperature and under the same conditions.

Reason:

This definition is needed because the term emittance is used in various sections of the code and in the definition for radiant barrier. It is consistent with the definition found in ASHRAE and ASTM standards.

Cost Impact

The code change proposal will not increase or decrease the cost of construction .

Adding a definition of EMITTANCE will neither increase or decrease construction costs. This is only a definition and is identical to the definition found in existing ASHRAE and ASTM standards.

Internal ID: 1090

G4-18

IBC: 202

Proponent: Ed Kullik, Chair, representing ICC Building Code Action Committee (bcac@iccsafe.org)

THIS CODE CHANGE WILL BE HEARD BY THE MEANS OF EGRESS COMMITTEE. SEE THE TENTATIVE HEARING ORDER FOR THIS COMMITTEE.

2018 International Building Code

SECTION 202 DEFINITIONS

Revise as follows:

[BE] GRADE FLOOR EMERGENCY ESCAPE AND RESCUE OPENING. ~~A window or other~~ An emergency escape and rescue opening located such that the ~~sill height~~ bottom of the clear opening is not more than 44 inches (1118 mm) above or below the finished ground level adjacent to the opening.

Reason:

This is one of a series of 11 proposals to coordinate the Emergency Escape and Rescue Openings (EERO) technical criteria in the IBC and IRC. Please see the proposal for the definition of Emergency Escape and Rescue Openings for additional information. Due to the code development schedule the proposals for IBC will be proposed in Group A and the proposals for IRC will be proposed in Group B.

The phrase “grade floor emergency escape and rescue opening” is used in IBC 1030.2 and IRC R310.2.1. The definition should be for the phrase as utilized in the text. The definition for EEROs includes “windows, doors or other similar devices.” Using the defined term EERO instead of “windows and other openings” encompasses all options.

What is a ‘sill’ is not clear – the change to “bottom of the clear opening” will set a specific height for consistency with technical criteria.

There will be a Group B proposal for the IRC.

This proposal is submitted by the ICC Building Code Action Committee (BCAC). BCAC was established by the ICC Board of Directors in July 2011 to pursue opportunities to improve and enhance assigned International Codes or portions thereof. In 2017 the BCAC has held 3 open meetings. In addition, there were numerous Working Group meetings and conference calls for the current code development cycle, which included members of the committee as well as any interested party to discuss and debate the proposed changes. Related documentation and reports are posted on the BCAC website at: <https://www.iccsafe.org/codes-tech-support/codes/codedevelopment-process/building-code-action-committee-bcac>.

Cost Impact

The code change proposal will not increase or decrease the cost of construction .

This coordination of an existing definition with no technical changes to the text.

Internal ID: 455

G5-18 Part I

PART 1:IBC: 202; IFC: 202;

PART 2: IPMC: 202 (New)

Proponent: Ed Kullik, Chair, representing ICC Building Code Action Committee (bcac@iccsafe.org)

THIS IS A TWO PART CODE CHANGE. PART 1 WILL BE HEARD BY THE MEANS OF EGRESS COMMITTEE. PART 2 WILL BE HEARD BY THE PROPERTY MAINTENANCE COMMITTEE. SEE THE TENTATIVE HEARING ORDER FOR THESE COMMITTEE.

2018 International Building Code

SECTION 202 DEFINITIONS

Revise as follows:

[BE] EMERGENCY ESCAPE AND RESCUE OPENING. An operable exterior window, door or other similar device that provides for a means of escape and access for rescue in the event of an emergency.

2018 International Fire Code

SECTION 202 GENERAL DEFINITIONS

Revise as follows:

[BE] EMERGENCY ESCAPE AND RESCUE OPENING. An operable exterior window, door or other similar device that provides for a means of escape and access for rescue in the event of an emergency.

Internal ID: 454

G5-18 Part II

IPMC: SECTION 202, 202 (New)

Proponent: Ed Kullik, Chair, representing ICC Building Code Action Committee (bcac@iccsafe.org)

2018 International Property Maintenance Code

SECTION 202 GENERAL DEFINITIONS

Add new definition as follows:

EMERGENCY ESCAPE AND RESCUE OPENING. An operable window, door or other similar device that provides for a means of escape and access for rescue in the event of an emergency.

Reason:

The intent of this proposal is to coordinate the definitions for emergency escape and rescue openings (EERO) between IBC, IRC, IEBC, IPMC, IFC. The EERO is always an exterior opening, and this descriptor is in the definition in IRC. The definition should appear in all codes where there are criteria for EEROs, so the definition should be added to IPMC and IEBC.

There will be a code proposal in Group B to coordinate IRC and IEBC.

This is the start of a series of 11 proposals to coordinate the requirements for Emergency Escape and Rescue Opening (EERO) requirements, primarily in the IBC and IRC, but also in the IEBC, IPMC and IFC. Due to the code development schedule the proposals for IBC, IPMC and IFC will be proposed in Group A and the proposals for IRC and IEBC will be proposed in Group B.

So that it is clear what the result of these overall proposals will be, the following is a clean version of what the text for EERO would be if all proposals are approved. The one section in the IRC that the BCAC is not proposing to duplicate in the IBC is the allowance for a EERO to be located below a deck.

This proposal is submitted by the ICC Building Code Action Committee (BCAC). BCAC was established by the ICC Board of Directors in July 2011 to pursue opportunities to improve and enhance assigned International Codes or portions thereof. In 2017 the BCAC has held 3 open meetings. In addition, there were numerous Working Group meetings and conference calls for the current code development cycle, which included members of the committee as well as any interested party to discuss and debate the proposed changes. Related documentation and reports are posted on the BCAC website at: <https://www.iccsafe.org/codes-tech-support/codes/codedevelopment-process/building-code-action-committee-bcac>.

This is what the EERO requirements would look like if all of the proposals are approved.

IBC

EMERGENCY ESCAPE AND RESCUE OPENING. An operable exterior window, door or other similar device that provides for a means of escape and access for rescue in the event of an emergency.

GRADE FLOOR EMERGENCY ESCAPE AND RESCUE OPENING. An emergency escape and rescue opening located such that the bottom of the clear opening is not more than 44 inches (1118 mm) above or below the finished ground level adjacent to the opening.

SECTION 1030

EMERGENCY ESCAPE AND RESCUE

1030.1 Where required. In addition to the means of egress required by this chapter emergency escape and rescue openings shall be provided in the following occupancies:

1. Group R-2 occupancies located in stories with only one exit or access to only one exit as permitted by Tables 1006.3.3(1) and 1006.3.3(2)
2. Group R-3 and R-4 occupancies.

Basements and sleeping rooms below the fourth story above grade plane shall have no fewer than one emergency escape and rescue opening in accordance with this section. Where basements contain one or more sleeping rooms, an emergency escape and rescue openings shall be required in each sleeping room, but shall not be required in adjoining areas of the basement. Such openings shall open directly into a public way or to a yard or court that opens to a public way.

Exceptions:

1. Basements with a ceiling height of less than 80 inches (2032 mm) shall not be required to have emergency escape

and rescue openings.

2. Emergency escape and rescue openings are not required from basements or sleeping rooms that have an exit door or exit access door that opens directly into a public way or to a yard, court or exterior egress balcony that opens to a public way.

3. Basements used only to house mechanical equipment and having not more than 200 square feet (18.6 m²) in floor area shall not be required to have emergency escape and rescue openings.

4. Storm shelters are not required to comply with this section where the shelter is constructed in accordance with ICC 500.

5. Within individual dwelling and sleeping units in Groups R-2 and R-3, where the building is equipped throughout with an automatic sprinkler system installed in accordance with Section 903.3.1.1, 903.3.1.2 or 903.3.1.3, sleeping rooms in basements shall not be required to have emergency escape and rescue openings provided that the basement has one of the following:

5.1. One means of egress and one emergency escape and rescue opening

5.2. Two means of egress.

1030.1.1 Operational constraints and opening control devices. Emergency escape and rescue openings shall be operational from inside the room without the use of keys or tools. Window opening control devices on windows serving as a required emergency escape and rescue opening shall comply with ASTM F2090.

1030.2 Emergency escape and rescue openings. Emergency escape and rescue opening shall have minimum dimensions in accordance with Section 1030.2.1 through 1030.2.3.

1030.2.1 Minimum size. Emergency escape and rescue openings shall have a minimum net clear opening of 5.7 square feet (0.53 m²).

Exception: The minimum net clear opening for grade-floor emergency escape and rescue openings shall be 5 square feet (0.46 m²).

1030.2.2 Minimum dimensions. The minimum net clear opening height dimension shall be 24 inches (610 mm). The minimum net clear opening width dimension shall be 20 inches (508 mm). The net clear opening dimensions shall be the result of normal operation of the opening.

1030.2.3 Maximum height from floor. Where a window is provided as the Emergency escape and rescue openings, such window shall have the bottom of the clear opening not greater than 44 inches (1118 mm) measured from the floor.

1030.3 Emergency escape and rescue doors. Where a door is provided as the required emergency escape and rescue opening, it shall be a swinging door or a sliding door.

1030.4 Area wells. An emergency escape and rescue opening with the bottom of the clear opening below the adjacent grade shall be provided with an area well in accordance with Sections 1030.4.1 through 1030.4.4.

1030.4.1 Minimum size. The minimum horizontal area of the area well shall be 9 square feet (0.84 m²), with a horizontal projection and width of not less than 36 inches (914 mm). The area well shall allow the emergency escape and rescue opening to be fully opened.

Exception: The ladder or steps required by Section 1030.4.2.1 shall be permitted to encroach not more than 6 inches (152 mm) into the required dimensions of the area well.

1030.4.2 Ladders or steps. Area wells with a vertical depth of more than 44 inches (1118 mm) shall be equipped with an approved permanently affixed ladder or steps. The ladder or steps shall not be obstructed by the emergency escape and rescue opening when the window or door is in the open position. Ladders or steps required by this section shall not be required to comply with Section 1011.

1030.4.2.1 Ladders. Ladders or rungs shall have an inside width of at least 12 inches (305 mm), shall project at least 3 inches (76 mm) from the wall and shall be spaced not more than 18 inches (457 mm) on center (o.c.) vertically for the full height of the area well.

1030.4.2.2 Steps. Steps shall have an inside width of at least 12 inches (305 mm), shall have minimum treads depth of 5 inches (127 mm) and a maximum riser height of 18 inches (457 mm) for the full height of the area well.

1030.4.3 Drainage. Area wells shall be designed for proper drainage by connecting to the building's foundation drainage system required by Section 1805.

Exception: A drainage system for area wells is not required where the foundation is on well-drained soil or sand-gravel mixture soils in accordance with the United Soil Classification System, Group I Soils, in accordance with Section 1803.5.1.

1030.4.4 Bars, grilles, covers and screens. Where Bars, grilles, covers, screens or similar devices are placed

over emergency escape and rescue openings, bulkhead enclosures, or area wells that serve such openings the minimum net clear opening size shall comply with Section 1030.1.1 through 1030.2.2 and 1030.4. Such devices shall be releasable or removable from the inside without the use of a key, tool or force greater than that which is required for normal operation of the emergency escape and rescue opening.

IRC

[RB] EMERGENCY ESCAPE AND RESCUE OPENING. An operable exterior window, door or similar device that provides for a means of escape and access for rescue in the event of an emergency.

GRADE FLOOR EMERGENCY ESCAPE AND RESCUE OPENING. An emergency escape and rescue opening located such that the bottom of the clear opening is not more than 44 inches (1118 mm) above or below the finished ground level adjacent to the opening.

SECTION R310

EMERGENCY ESCAPE AND RESCUE OPENINGS

R310.1 Where required. Basements, habitable attics and every sleeping room shall have no fewer than one emergency escape and rescue opening in accordance with this section. Where basements contain one or more sleeping rooms, an emergency escape and rescue opening shall be required in each sleeping room, but shall not be required in adjoining areas of the basement. Such openings shall open directly into a public way, or to a yard or court that opens to a public way.

Exceptions:

1. Basements with a ceiling height of less than 80 inches (2032 mm) shall not be required to have emergency escape and rescue openings.
2. Emergency escape and rescue openings are not required from basements or sleeping rooms that have an exit door or exit access door that opens directly into a public way or to a yard, or that opens to a public way.
3. Basements used only to house mechanical equipment not exceeding a total floor area of 200 square feet (18.58 m²) shall not be required to have emergency escape and rescue openings.
4. Storm shelters are not required to comply with this section where the shelter is constructed in accordance with ICC 500.
5. Where the dwelling or townhouse is equipped with an automatic sprinkler system installed in accordance with Section P2904, sleeping rooms in basements shall not be required to have emergency escape and rescue openings provided that the basement has one of the following:
 - 5.1. One means of egress complying with Section R311 and one emergency escape and rescue opening.
 - 5.2. Two means of egress complying with Section R311.

R310.1.1 Operational constraints and opening control devices. Emergency escape and rescue openings shall be operational from the inside of the room without the use of keys, or tools. Window opening control devices on windows serving as a required emergency escape and rescue opening shall comply with ASTM F2090.

R310.2 Emergency escape and rescue openings. Emergency escape and rescue openings shall have minimum dimensions in accordance with Section R310.2.1 through R310.2.3.

R310.2.1 Minimum size. Emergency and escape rescue openings shall have a net clear opening of not less than 5.7 square feet (0.530 m²).

Exception: The minimum net clear opening for grade-floor emergency escape and rescue openings shall be 5 square feet (0.465 m²).

R310.2.2 Minimum dimensions. The minimum net clear opening height dimension shall be 24 inches (610 mm). The minimum net clear opening width dimension shall be 20 inches (508 mm). The net clear opening dimensions shall be the result of normal operation of the opening.

R310.2.3 Maximum height from floor. Where a window is provided as the emergency escape and rescue openings such window shall have the bottom of the clear opening not greater than 44 inches (1118 mm) above the floor.

R310.3 Emergency escape and rescue doors. Where a door is provided as the required emergency escape and rescue opening, it shall be a swinging door or a sliding door.

R310.4 Area wells. An emergency escape and rescue opening with the bottom of the clear opening below the adjacent grade shall be provided with an area well in accordance with Sections R310.4.1 through R310.4.4.

R310.4.1 Minimum size. The horizontal area of the area well shall be not less than 9 square feet (0.9 m²), with a horizontal projection and width of not less than 36 inches (914 mm). The area well shall allow the emergency escape and rescue opening to be fully opened.

Exception: The ladder or steps required by Section R310.4.2.1 shall be permitted to encroach not more than 6 inches (152 mm) into the required dimensions of the area well.

R310.4.2 Ladder and steps. Area wells with a vertical depth greater than 44 inches (1118 mm) shall be equipped with a an approved permanently affixed ladder or steps. The ladder or steps shall not be obstructed by the emergency escape and rescue opening when the window or door is in the open position. Ladders or steps required by this section shall not be required to comply with Section R311.7.

R310.4.2.1 Ladders. Ladders or rungs shall have an inside width of at least 12 inches (305 mm), shall project at least 3 inches (76 mm) from the wall and shall be spaced not more than 18 inches (457 mm) on center (o.c.) vertically for the full height of the area well.

R310.4.2.2 Steps. Steps shall have an inside width of at least 12 inches (305 mm), shall have minimum treads depth of 5 inches (127 mm) and a maximum riser height of 18 inches (457 mm) for the full height of the area well.

R310.4.3 Drainage. Area wells shall be designed for proper drainage by connecting to the building's foundation drainage system required by Section R405.1.

Exception: A drainage system for area wells is not required where the foundation is on well-drained soil or sand-gravel mixture soils in accordance with the United Soil Classification System, Group I Soils, as detailed in Table R405.1.

R310.4.4 Bars, grilles, covers and screens. Where bars, grilles, covers, screens or similar devices are placed over emergency escape and rescue openings, bulkhead enclosures, or area wells that serve such openings, the minimum net clear opening size shall comply with Sections R310.2 through R310.2.2 and R310.4.1. Such devices shall be releasable or removable from the inside without the use of a key or tool or force greater than that required for the normal operation of the escape and rescue opening.

R310.5 Emergency escape and rescue openings under decks and porches. Emergency escape and rescue openings installed under decks and porches shall be fully operable and provide a path not less than 36 inches (914 mm) in height to a yard or court.

IFC

[BE] EMERGENCY ESCAPE AND RESCUE OPENING. An operable exterior window, door or other similar device that provides for a means of escape and access for rescue in the event of an emergency.

403.10.3.6 Resident participation in drills. Emergency evacuation drills shall involve the actual evacuation of residents to a selected assembly point and shall provide residents with experience in exiting through all required exits. All required exits shall be used during emergency evacuation drills.

Exception: Actual exiting from emergency escape and rescue openings shall not be required. Opening the emergency escape and rescue openings and signaling for help shall be an acceptable alternative.

1031.7 Emergency escape and rescue openings. Required emergency escape and rescue openings shall be maintained in accordance with the code in effect at the time of construction, and both of the following:

1. Required emergency escape and rescue openings shall be operational from the inside of the room without the use of keys or tools.
2. Bars, grilles, grates or similar devices are allowed to be placed over emergency escape and rescue openings provided the minimum net clear opening size complies with the code that was in effect at the time of construction and the unit is equipped with smoke alarms installed in accordance with Section 907.2.11 of the International Building Code. Such devices shall be releasable or removable from the inside without the use of a key, tool or force greater than that which is required for normal operation of the emergency escape and rescue opening.

IEBC

[BE] EMERGENCY ESCAPE AND RESCUE OPENING. An operable exterior window, door or other similar device that provides for a means of escape and access for rescue in the event of an emergency.

IEBC (prescriptive method)

505.4 Emergency escape and rescue openings. Emergency escape and rescue openings shall be operational from the inside of the room without the use of keys or tools.

Bars, grilles, grates or similar devices are allowed to be placed over emergency escape and rescue openings provided the minimum net clear opening size complies with the code that was in effect at the time of construction and the unit is equipped with smoke alarms installed in accordance with Section 907.2.11 of the International Building Code. Such devices shall be releasable or removable from the inside without the use of a key, tool or force greater than that which is required for normal operation of the emergency escape and rescue opening.

IEBC (Alterations Level 1)

701.4 Emergency escape and rescue openings. Emergency escape and rescue openings shall be operational

from the inside of the room without the use of keys or tools.

Bars, grilles, grates or similar devices are allowed to be placed over emergency escape and rescue openings provided the minimum net clear opening size complies with the code that was in effect at the time of construction and the unit is equipped with smoke alarms installed in accordance with Section 907.2.11 of the International Building Code. Such devices shall be releasable or removable from the inside without the use of a key, tool or force greater than that which is required for normal operation of the emergency escape and rescue opening.

IPMC

[BE] EMERGENCY ESCAPE AND RESCUE OPENING. An operable exterior window, door or other similar device that provides for a means of escape and access for rescue in the event of an emergency.

[F] 702.4 Emergency escape and rescue openings. Required emergency escape and rescue openings shall be maintained in accordance with the code in effect at the time of construction, and both of the following:

1. Required emergency escape and rescue openings shall be operational from the inside of the room without the use of keys or tools.

2. Bars, grilles, grates or similar devices are permitted to be placed over emergency escape and rescue openings provided the minimum net clear opening size complies with the code that was in effect at the time of construction and the unit is equipped with smoke alarms installed in accordance with Section 907.2.11 of the International Building Code. Such devices shall be releasable or removable from the inside without the use of a key, tool or force greater than that which is required for normal operation of the escape and rescue opening.

Cost Impact

The code change proposal will not increase or decrease the cost of construction .

This coordination of an existing definition with no technical changes to the text.

Internal ID: 3406

G6-18

IBC: SECTION 202, 202 (New)

Proponent: John Woestman, Kellen Co., representing Extruded Polystyrene Foam Association (XPSA)
(jwoestman@kellencompany.com)

THIS CODE CHANGE WILL BE HEARD BY THE IBC FIRE SAFETY COMMITTEE. SEE THE TENTATIVE HEARING ORDER FOR THIS COMMITTEE.

2018 International Building Code

SECTION 202 DEFINITIONS

Add new definition as follows:

INSULATING SHEATHING A rigid panel or board insulation material having a thermal resistance of not less than R-2 of the core material with properties suitable for use on walls, floors, roofs, or foundations.

Reason:

This proposed definition is based on the similar definition in the IRC. The proposal improves the definition to better fit context of use of this term and material in the IBC and IRC. For example, the term "rigid panel" is added to recognize composite assemblies that are not homogenous. The clarification of use in walls, floors, roofs, and foundations reflects common use of foam plastic insulating sheathing materials. The current IRC definition is as follows:

INSULATING SHEATHING: An insulating board having a thermal resistance of not less than R-2 of the core material.

Cost Impact

The code change proposal will not increase or decrease the cost of construction .

The proposed definition is for a term already used in the IBC and will have no cost impact.

Internal ID: 978

G7-18

IBC: SECTION 202, 202

Proponent: Misty Guard, representing Bradley Corporation (Misty.Guard@bradleycorp.com)

THIS CODE CHANGE WILL BE HEARD BY THE IBC FIRE SAFETY COMMITTEE. SEE THE TENTATIVE HEARING ORDER FOR THIS COMMITTEE.

2018 International Building Code

SECTION 202 DEFINITIONS

Revise as follows:

[BF] INTERIOR WALL AND CEILING FINISH. The exposed interior surfaces of buildings, including but not limited to: fixed or movable walls and partitions; ~~toilet room privacy partitions~~; columns; ceilings; and interior wainscoting, paneling or other finish applied structurally or for decoration, acoustical correction, surface insulation, structural fire resistance or similar purposes, but not including trim.

Reason:

Toilet partitions and urinal partitions are regulated by Section 1209. It was incorrect to add “toilet room privacy partitions” to the interior wall and ceiling finish. The important aspect of water closet and urinal partitions is the sanitation of the wall surfaces, as well as, the cleanability. Another important aspect is privacy when using plumbing fixtures. While the privacy for using a water closet seems obvious, studies have shown the plumbing industry the need to provide privacy even when using a urinal in the men’s room. Other considerations for water closet and urinal partitions are resistance to scratching and graffiti. Manufacturers have developed high quality partitions to meet the needs of commercial buildings.

The interior finish requirements are concerned with the fire aspects of a building component. However, there is no history of a fire concern with water closet and urinal partitions. A study was completed by NFPA Research entitled, “Non-Residential Structure Fires That Originated in Lavatories, Locker Rooms or Coat Check Rooms,” dated November 2017, authored by Marty Ahrens. The report shows no issue with water closet or urinal partitions. There are no fire deaths reported from fires originating in a commercial toilet room. Hence, the perceived fire hazard does not exist with partitions in commercial toilet rooms and bathrooms. It is more important to emphasize the sanitary and health issues as identified in Section 1209.

Bibliography:

Ahrens, M. (2017). Non-Residential Structure Fires that Originated in Lavatories, Locker Rooms or Coat Check Rooms. Quincy, MA: NFPA Research.

<https://www.dropbox.com/sh/0e177098908o5up/AADoei27Mnp3XfjaA9rreawQa?dl=0>: Established 1.24.18

Cost Impact

The code change proposal will not increase or decrease the cost of construction .

There is no cost associated with this change since the code change will merely provide other options for complying with the current requirements. There are no new mandatory requirements being added.

Internal ID: 1844

G8-18

IBC: SECTION 202, 202 (New)

Proponent: James Smith, American Wood Council, representing ICC Region III Code Development Committee (jsmith@awc.org); Edward Lisinski, City of West Allis, WI, representing Self (elisinski@westalliswi.gov)

2018 International Building Code

SECTION 202 DEFINITIONS

Add new definition as follows:

MOTOR VEHICLE. A vehicle on wheels or other conveyance system, having its own motor to propel the vehicle, and not running on rails or tracks, for use on land, streets, or highways; such as an automobile, truck, bus, forklift, and which is manually operated.

Reason:

The reason for this proposal is to eliminate the confusion about what types of vehicles are applied to the code sections that regulate "MOTOR VEHICLES". There are numerous code sections that apply to MOTOR VEHICLES, but even though there is a definition for "COMMERCIAL MOTOR VEHICLE", there is no clear definition as to what a MOTOR VEHICLE is even though the term is embedded in that other definition. The same is true for the definitions of "Private Garage" and "Repair Garage". There are 15 locations in the IBC and 5 sections in the IMC that include the term. If you go with a rudimentary explanation, it is a vehicle with a motor. That could include cars, trucks, motorcycles, boats, trains, lawnmowers, children's toys, electric golf carts, electric scooters, airplanes and many more vehicles. We feel it is clear that the code does not intend children's toys to be regulated by those sections and airplanes are regulated within the sections of the code referring to aircraft, or Aircraft-Related Occupancies (Section 412) and not intended to be also regulated by the Motor-Vehicle-Related Occupancies Section (Section 406) of the code. A clear definition ensures that all provisions of the code that have requirements for MOTOR VEHICLES are applied uniformly.

In reviewing the code provisions that regulated MOTOR VEHICLES we felt they could be grouped into three basic areas:

1. Impact protection from operator error
2. Fumes related to fuel vapor accumulation related to internal combustion powered motor vehicles that are not being operated
3. Fumes related to combustion of the internal combustion engines when the motor is being operated.

We believe the proposed definition should include all vehicles with motors that are intended to be regulated by the various code sections. For that reason the proposed definition excludes any vehicle used in the air, water or on rails. The definition would only include vehicles such as cars, motorcycles, trucks, buses, recreational vehicles, forklifts and similar vehicles that are stored, repaired or operated inside a building. Although a definition could be written to exclude vehicles that are powered by electric motors and which do not produce fumes associated with fuel of the combustion process, we did not feel there were enough of those to create two definitions in this proposal.

Cost Impact

The code change proposal will not increase or decrease the cost of construction .

The addition of the definition is only being provided to assist users of the code when confronted by those code sections that regulate MOTOR VEHICLES. There are no added regulatory provisions.

Internal ID: 731

G9-18

IBC: SECTION 202, 202

Proponent: Mike Fischer, Kellen Company, representing The Plastic Glazing Coalition of the American Chemistry Council (mfischer@kellencompany.com)

2018 International Building Code

SECTION 202 DEFINITIONS

Revise as follows:

[B G] WALKWAY, PEDESTRIAN. A structure that provides a walkway used exclusively as ~~a~~ for pedestrian trafficway traffic.

Reason:

The IBC includes technical requirements for pedestrian walkways that are clearly intended for specific structures such as skybridges, elevated walkways, and similar structures. Unfortunately, the definition for pedestrian walkways is overly broad and would apply to sidewalks, paths, and similar lot features. By indicating that the walkway is an actual structure, the definition is more appropriately scoped.

Try this Google image search and see all of the different types of structures- including footpaths and sidewalks- that appear:

https://www.google.com/search?q=Pedestrian+Walkway&source=lnms&tbm=isch&sa=X&ved=0ahUKEwiohvisn9DYAhWK7IMKHRQ-BkEQ_AUICigB&biw=1536&bih=769

One such example of a code provision that is intended to apply to elevated bridges that connect two separate buildings is found in Section 3104.5.1:

3104.5.1 Fire barriers. Pedestrian walkways shall be separated from the interior of the building by not less than 2-hour fire barriers constructed in accordance with Section 707 and Sections 3104.5.1.1 through 3104.5.1.3.

The proposal cleans up the definition to ensure that provisions (such as the 2-hour rating above) for structures like skywalks or bridges aren't extended where they aren't intended to apply.

Cost Impact

The code change proposal will not increase or decrease the cost of construction .

The change is editorial in nature and makes no real technical changes to the code.

Internal ID: 2060

G10-18

IBC: 202

Proponent: Marcelo Hirschler, GBH International, representing GBH International (gbhint@aol.com); Mike Fischer, Kellen Company, representing The Plastic Glazing Coalition of the American Chemistry Council

THIS CODE CHANGE WILL BE HEARD BY THE IBC FIRE SAFETY COMMITTEE. SEE THE TENTATIVE HEARING ORDER FOR THIS COMMITTEE

2018 International Building Code

Delete without substitution:

~~**[BF] PLASTIC, APPROVED.** Any thermoplastic, thermosetting or reinforced thermosetting plastic material that conforms to combustibility classifications specified in the section applicable to the application and plastic type.~~

Reason: Hirschler

This term (plastic, approved) is not used in ICC codes.

The term "approved plastic" is also not used in isolation but always in conjunction with a specific requirement.

In the 2015 IBC code there were 3 instances of generic references to "approved plastic" and they were removed by proposals S311 and S312. Proposal S311 revised section H106.1.1 to state "approved plastic complying with the requirements of Section 2606.4", which are the requirements for light transmitting plastics. Proposal S312 deleted the references to "approved plastic" and replaced them with references to plastics complying with section H107.1.1.

The codes do not have "approved plastics" just like they do not have "approved wood" or "approved steel" but the codes have (as they should) plastics that are approved for use only when they comply with certain requirements.

Fischer

The proposal removes an unnecessary and potentially confusing definition of "approved plastics". This definition is used only once in the code; there are many more instances where it could be applied- IF that is necessary. The IBC has a definition of approved and contains clear provisions for the materials covered by Section H106.1.1 with the reference to fire testing in Section 2606.4. It is unnecessary to have a definition that is redundant to the code requirements. Italicizing the word "approved" makes it clear the IBC definition of approved applies.

Note that it is the intent of this proposal that the word "approved" be italicized in the first sentence of Section H106.1.1. cdpACCESS would not allow this change. Section H106.1.1 is as follows.

H106.1.1 Internally illuminated signs. Except as provided for in Section 2611, where internally illuminated signs have facings of wood or of approved plastic complying with the requirements of Section 2606.4, the area of such facing section shall be not more than 120 square feet (11.16 m²) and the wiring for electric lighting shall be entirely enclosed in the sign cabinet with a clearance of not less than 2 inches (51 mm) from the facing material. The dimensional limitation of 120 square feet (11.16 m²) shall not apply to sign facing sections made from flame-resistant-coated fabric (ordinarily known as "flexible sign face plastic") that weighs less than 20 ounces per square yard (678 g/m²) and that, when tested in accordance with NFPA 701, meets the fire propagation performance requirements of both Test 1 and Test 2 or that, when tested in accordance with an approved test method, exhibits an average burn time of 2 seconds or less and a burning extent of 5.9 inches (150 mm) or less for 10 specimens.

Cost Impact

The code change proposal will not increase or decrease the cost of construction .

This simply deletes an unused and misleading definition.

The proposal is editorial and changes no technical requirements.

Internal ID: 168

G11-18

IBC: SECTION 202, 202

Proponent: Mike Fischer, Kellen Company, representing The Plastic Glazing Coalition of the American Chemistry Council (mfischer@kellencompany.com)

THIS CODE CHANGE WILL BE HEARD BY THE IBC FIRE SAFETY COMMITTEE. SEE THE TENTATIVE HEARING ORDER FOR THIS COMMITTEE.

2018 International Building Code

SECTION 202 DEFINITIONS

Revise as follows:

[BF] PLASTIC GLAZING. Plastic materials that are glazed or set in a frame or sash or are otherwise supported.

Reason:

The current code indicates that plastic glazing by definition is set in a frame or sash; there are other means of supporting plastic glazing including through fastening. The revised definition acknowledges other supporting options.

Cost Impact

The code change proposal will not increase or decrease the cost of construction .

The proposal is editorial and does not alter current requirements.

Internal ID: 2035

G12-18

IBC: SECTION 202, 202

Proponent: Craig Conner, self, representing self (craig.conner@mac.com); Joseph Lstiburek, representing Self (joe@buildingsscience.com)

THIS CODE CHANGE WILL BE HEARD BY THE IBC FIRE SAFETY COMMITTEE. SEE THE TENTATIVE HEARING ORDER FOR THIS COMMITTEE.

2018 International Building Code

SECTION 202 DEFINITIONS

Revise as follows:

[BF] VAPOR PERMEABLE. The property of having a moisture vapor permeance rating of 5 perms (2.9×10^{-10} kg/Pa \times s \times m²) or greater, when tested in accordance with ~~the desiccant method using~~ Procedure A or Procedure B of ASTM E96. A vapor permeable material permits the passage of moisture vapor.

Reason:

Relying on only Procedure A is inaccurate and misleading. The existing code language limits the use of newer materials and systems such as “smart” materials that can be “tuned” to address moisture control issues in different climate zones. The existing definition applied to asphalt felts and Type D coated papers and dates back over a half a century. For Type D papers the original Federal Specification UUP-147 was issued in 1948. The technical rationale for this change can be found in the following link:

<https://buildingsscience.com/documents/building-science-insights/bsi-099-its-all-relative> (as accessed on January 10, 2018)

Cost Impact

The code change proposal will not increase or decrease the cost of construction .

This adds a test procedure that is more appropriate for some products.

Internal ID: 1316

G13-18

IBC: SECTION 303.1.5 (New), 304.2 (New), 304.3 (New), 304.4 (New), 305.3 (New), 306.2.1 (New), 308.2, 308.3.1, 308.4, 309.3 (New), 310.1, 311.1.2 (New), 311.2.1 (New), 311.2.2 (New), 311.3, 311.3.1 (New), 312.2 (New), 312.3 (New)

Proponent: Ed Kullik, Chair, representing ICC Building Code Action Committee (bcac@iccsafe.org)

2018 International Building Code

SECTION 303 ASSEMBLY GROUP A

303.1 Assembly Group A. Assembly Group A occupancy includes, among others, the use of a building or structure, or a portion thereof, for the gathering of persons for purposes such as civic, social or religious functions; recreation, food or drink consumption or awaiting transportation.

Add new text as follows:

303.1.5 Special amusement buildings. Special amusement buildings shall comply with Section 411.

SECTION 304 BUSINESS GROUP B

Revise as follows:

304.1 Business Group B. Business Group B occupancy includes, among others, the use of a building or structure, or a portion thereof, for office, professional or service-type transactions, including storage of records and accounts. Business occupancies shall include, but not be limited to, the following:

- Airport traffic control towers
- *Ambulatory care facilities*
- Animal hospitals, kennels and pounds
- Banks
- Barber and beauty shops
- Car wash
- Civic administration
- *Clinic, outpatient*
- Dry cleaning and laundries: pick-up and delivery stations and self-service
- Educational occupancies for students above the 12th grade, including higher education laboratories.
- Electronic data processing
- Food processing establishments and commercial kitchens not associated with restaurants, cafeterias and similar dining facilities not more than 2,500 square feet (232 m²) in area.
- Laboratories: testing and research
- Motor vehicle showrooms
- Post offices
- Print shops
- Professional services (architects, attorneys, dentists, physicians, engineers, etc.)
- Radio and television stations
- Telephone exchanges
- Training and skill development not in a school or academic program (this shall include, but not be limited to, tutoring centers, martial arts studios, gymnastics and similar uses regardless of the ages served, and where not classified as a Group A occupancy).

Add new text as follows:

304.2 Airport traffic control towers. Airport traffic control towers shall comply with Section 412.2.

304.3 Ambulatory care facilities. Ambulatory care facilities shall comply with Section 422.

304.4 Higher education laboratories. Higher education laboratories shall comply with Section 428.

SECTION 305 EDUCATIONAL GROUP E

305.3 Storm shelters in Group E occupancies. Storm shelters shall be provided for Group E occupancies where required by Section 423.4.

SECTION 306 FACTORY GROUP F

Revise as follows:

306.2 Moderate-hazard factory industrial, Group F-1. Factory industrial uses that are not classified as Factory Industrial F-2 Low Hazard shall be classified as F-1 Moderate Hazard and shall include, but not be limited to, the following:

- Aircraft (manufacturing, not to include repair)
- Appliances
- Athletic equipment
- Automobiles and other motor vehicles
- Bakeries
- Beverages: over 16-percent alcohol content
- Bicycles
- Boats
- Brooms or brushes
- Business machines
- Cameras and photo equipment
- Canvas or similar fabric
- Carpets and rugs (includes cleaning)
- Clothing
- Construction and agricultural machinery
- Disinfectants
- Dry cleaning and dyeing
- Electric generation plants
- Electronics
- Engines (including rebuilding)
- Food processing establishments and commercial kitchens not associated with restaurants, cafeterias and similar dining facilities more than 2,500 square feet (232 m²) in area.
- Furniture
- Hemp products
- Jute products
- Laundries
- Leather products
- Machinery
- Metals
- Millwork (sash and door)
- Motion pictures and television filming (without spectators)
- Musical instruments
- Optical goods

- Paper mills or products
- Photographic film
- Plastic products
- Printing or publishing
- Recreational vehicles
- Refuse incineration
- Shoes
- Soaps and detergents
- Textiles
- Tobacco
- Trailers
- Upholstering
- Wood; distillation
- Woodworking (cabinet)

Add new text as follows:

306.2.1 Aircraft manufacturing facilities. Aircraft manufacturing facilities shall comply with Section 412.6.

SECTION 308 INSTITUTIONAL GROUP I

Revise as follows:

308.2 Institutional Group I-1. Institutional Group I-1 occupancy shall include buildings, structures or portions thereof for more than 16 persons, excluding staff, who reside on a 24-hour basis in a supervised environment and receive custodial care. Buildings of Group I-1 shall be classified as one of the occupancy conditions specified in Section 308.2.1 or 308.2.2 ~~and shall comply with Section 420.~~ This group shall include, but not be limited to, the following:

- Alcohol and drug centers
- Assisted living facilities
- Congregate care facilities
- *Group homes*
- Halfway houses
- Residential board and care facilities
- Social rehabilitation facilities

308.3 Institutional Group I-2. Institutional Group I-2 occupancy shall include buildings and structures used for *medical care* on a 24-hour basis for more than five persons who are *incapable of self-preservation*. This group shall include, but not be limited to, the following:

- *Foster care facilities*
- *Detoxification facilities*
- *Hospitals*
- *Nursing homes*
- *Psychiatric hospitals*

308.3.1 Occupancy conditions. Buildings of Group I-2 shall be classified as one of the occupancy conditions specified in Section 308.3.1.1 or 308.3.1.2 ~~and shall comply with Section 407.~~

308.4 Institutional Group I-3. Institutional Group I-3 occupancy shall include buildings and structures that are inhabited by more than five persons who are under restraint or security. A Group I-3 facility is occupied by persons who are generally *incapable of self-preservation* due to security measures not under the occupants' control. This group shall include, but not be limited to, the following:

- Correctional centers
- Detention centers
- Jails
- Prerelease centers
- Prisons
- Reformatories

Buildings of Group I-3 shall be classified as one of the occupancy conditions specified in Sections 308.4.1 through 308.4.5 (~~see Section 408.1~~) and shall comply with Section 408.

SECTION 309 MERCANTILE GROUP M

Add new text as follows:

309.1 Mercantile Group M. Mercantile Group M occupancy includes, among others, the use of a building or structure or a portion thereof for the display and sale of merchandise, and involves stocks of goods, wares or merchandise incidental to such purposes and accessible to the public. Mercantile occupancies shall include, but not be limited to, the following:

- Department stores
- Drug stores
- Markets
- Greenhouses for display and sale of plants that provide public access.
- Motor fuel-dispensing facilities
- Retail or wholesale stores
- Sales rooms

309.3 Motor fuel-dispensing facilities. Motor fuel-dispensing facilities shall comply with Section 406.7.

SECTION 310 RESIDENTIAL GROUP R

Revise as follows:

310.1 Residential Group R. Residential Group R includes, among others, the use of a building or structure, or a portion thereof, for sleeping purposes when not classified as an Institutional Group I or when not regulated by the International Residential Code. Group R occupancies not constructed in accordance with the International Residential Code as permitted by Sections 301.4.1 and 301.4.2 shall comply with Section 420.

SECTION 311 STORAGE GROUP S

Add new text as follows:

311.1.2 Combustible storage. High-piled stock or rack storage, or attic, under-floor and concealed spaces used for storage of combustible materials, shall be in accordance with Section 413.

311.2 Moderate-hazard storage, Group S-1. Storage Group S-1 occupancies are buildings occupied for storage uses that are not classified as Group S-2, including, but not limited to, storage of the following:

- Aerosol products, Levels 2 and 3
- Aircraft hangar (storage and repair)
- Bags: cloth, burlap and paper
- Bamboos and rattan
- Baskets
- Belting: canvas and leather
- Books and paper in rolls or packs
- Boots and shoes

- Buttons, including cloth covered, pearl or bone
- Cardboard and cardboard boxes
- Clothing, woolen wearing apparel
- Cordage
- Dry boat storage (indoor)
- Furniture
- Furs
- Glues, mucilage, pastes and size
- Grains
- Horns and combs, other than celluloid
- Leather
- Linoleum
- Lumber
- Motor vehicle repair garages complying with the maximum allowable quantities of hazardous materials listed in Table 307.1(1) (see Section 406.8)
- Photo engravings
- Resilient flooring
- Self-service storage facility (mini-storage)
- Silks
- Soaps
- Sugar
- Tires, bulk storage of
- Tobacco, cigars, cigarettes and snuff
- Upholstery and mattresses
- Wax candles

311.2.1 Aircraft hangars. Aircraft hangars used for storage or repair shall comply with Section 412.3.

311.2.2 Motor vehicle repair garages. Motor vehicle repair garages shall comply with Section 406.8.

311.3 Low-hazard storage, Group S-2. Storage Group S-2 occupancies include, among others, buildings used for the storage of noncombustible materials such as products on wood pallets or in paper cartons with or without single thickness divisions; or in paper wrappings. Such products are permitted to have a negligible amount of plastic *trim*, such as knobs, handles or film wrapping. Group S-2 storage uses shall include, but not be limited to, storage of the following:

- Asbestos
- Beverages up to and including 16-percent alcohol in metal, glass or ceramic containers
- Cement in bags
- Chalk and crayons
- Dairy products in nonwaxed coated paper containers
- Dry cell batteries
- Electrical coils
- Electrical motors
- Empty cans
- Food products
- Foods in noncombustible containers
- Fresh fruits and vegetables in nonplastic trays or containers

- Frozen foods
- Glass
- Glass bottles, empty or filled with noncombustible liquids
- Gypsum board
- Inert pigments
- Ivory
- Meats
- Metal cabinets
- Metal desks with plastic tops and *trim*
- Metal parts
- Metals
- Mirrors
- Oil-filled and other types of distribution transformers
- ~~Parking~~ Public parking garages, open or enclosed
- Porcelain and pottery
- Stoves
- Talc and soapstones
- Washers and dryers

311.3.1 Public parking garages. Public parking garages shall comply with Section 406.4 and the additional requirements of Section 406.5 for open parking garages or Section 406.6 for enclosed parking garages.

SECTION 312 UTILITY AND MISCELLANEOUS GROUP U

312.2 Private garages and carports. Private garages and carports shall comply with Section 406.3.

312.3 Residential aircraft hangars. Aircraft hangars accessory to a one- or two-family residence shall comply with Section 412.4.

Reason:

During the 2015-2015 code development cycle, a series of proposals were submitted to relocate the bulk of the detailed use and occupancy requirements in Chapter 4 to other sections of the code, primarily Chapter 3. The primary justification was concern that some code users may overlook key Chapter 4 criteria that apply to their buildings. The proposals were all defeated, most of them overwhelmingly.

The concern still remains, especially as Chapter 4 remains a dumping ground for use- or occupancy-related provisions that don't have a clear home elsewhere in the code. The BCAC elected to revisit the issue, but rather than taking a chainsaw to the provisions and clearing out huge clumps opted for a more surgical approach. Primarily, the BCAC proposes to add a series of pointers from the appropriate occupancy groups in Chapter 3 to the relevant provisions in Chapter 4. Pointers to uses in Chapter 4 which can occur in a variety of different occupancy groups are added in Section 302. These changes will highlight for architects, engineers and building officials when detailed provisions in Chapter 4 apply to a building, or portion thereof, which they are designing or reviewing.

This proposal is submitted by the ICC Building Code Action Committee (BCAC). BCAC was established by the ICC Board of Directors in July 2011 to pursue opportunities to improve and enhance assigned International Codes or portions thereof. In 2017 the BCAC has held 3 open meetings. In addition, there were numerous Working Group meetings and conference calls for the current code development cycle, which included members of the committee as well as any interested party to discuss and debate the proposed changes. Related documentation and reports are posted on the BCAC website at: <https://www.iccsafe.org/codes-tech-support/codes/code-development-process/building-code-action-committee-bcac>.

Cost Impact

The code change proposal will not increase or decrease the cost of construction .

The code change proposal will not increase or decrease the cost of construction. This is an editorial reorganization to place requirements in a more appropriate location.

G14-18

IBC: 303.1, 303.1.3

Proponent: Ed Kullik, Chair, representing ICC Building Code Action Committee (bcac@iccsafe.org)

2018 International Building Code

SECTION 303 ASSEMBLY GROUP A

Revise as follows:

303.1 Assembly Group A. Assembly Group A occupancy includes, among others, the use of a building or structure, or a portion thereof, for the gathering of persons for purposes such as civic, social or religious functions; recreation, food or drink consumption or awaiting transportation.

303.1.3 Associated with Group E occupancies. A room or space used for assembly purposes that is associated with a Group E occupancy, with an occupant load of 300 or less, is not considered a separate occupancy.

Reason:

To be consistent, the exceptions for assembly spaces in Section 303.1.1 through 303.1.4 (below) seem to indicate that the exceptions are intended for small spaces. However, the language in 303.1.3 has been widely interpreted. Some people feel this should be limited to spaces just typically open to students - such as libraries, music rooms, band rooms, and cafeterias. Others have interpreted this to include large gymnasiums and auditoriums with significant seating. While a school basketball game may be a school function, there would be students from another school, as well as significant number of the public, including a high percentage of families. The same concern for large number of the public also hold true in an auditorium.

303.1.1 Small buildings and tenant spaces. A building or tenant space used for assembly purposes with an occupantload of less than 50 persons shall be classified as a Group B occupancy.

303.1.2 Small assembly spaces. The following rooms and spaces shall not be classified as Assembly occupancies:

1. A room or space used for assembly purposes with an occupant load of less than 50 persons and accessory to another occupancy shall be classified as a Group B occupancy or as part of that occupancy.
2. A room or space used for assembly purposes that is less than 750 square feet (70 m2) in area and accessory to another occupancy shall be classified as a Group B occupancy or as part of that occupancy.

303.1.3 Associated with Group E occupancies. A room or space used for assembly purposes that is associated with a Group E occupancy is not considered a separate occupancy.

303.1.4 Accessory to places of religious worship. Accessory religious educational rooms and religious auditoriums with occupant loads of less than 100 per room or space are not considered separate occupancies.

This also may be considered a conflict with Section 302.1 which states "A room or space that is intended to be occupied at different times for different purposes shall comply with all of the requirements that are applicable to each of the purposes for which the room or space will be occupied."

This proposal is submitted by the ICC Building Code Action Committee (BCAC). BCAC was established by the ICC Board of Directors in July 2011 to pursue opportunities to improve and enhance assigned International Codes or portions thereof. In 2017 the BCAC has held 3 open meetings. In addition, there were numerous Working Group meetings and conference calls for the current code development cycle, which included members of the committee as well as any interested party to discuss and debate the proposed changes. Related documentation and reports are posted on the BCAC website at: <https://www.iccsafe.org/codes-tech-support/codes/code-development-process/building-code-action-committee-bcac>.

Cost Impact

The code change proposal will increase the cost of construction .

This code change proposal will increase the cost of construction. Sprinkler system installation in new construction for a Group A can vary from \$1.00 to \$3.00 per square foot. This proposal will require larger gymnasiums and auditoriums associated with a Group E occupancy to be protected with a fire suppression system in areas where the previous interpretation was to allow these larger spaces to be considered part of the Group E occupancy.

Internal ID: 183

G15-18 Part I

PART I - IBC: 303.4, 309.1

PART II - IBC: TABLE 1004.5, (IFC[BE] TABLE 1004.5)

Proponent: Micah Chappell, representing City of Seattle (micah.chappell@seattle.gov)

THIS IS A 2 PART CODE CHANGE PROPOSAL. PART I WILL BE HEARD BY THE GENERAL CODE DEVELOPMENT COMMITTEE. PART II WILL BE HEARD BY THE MEANS OF EGRESS COMMITTEE. SEE THE TENTATIVE HEARING ORDERS FOR THESE COMMITTEES.

2018 International Building Code

Revise as follows:

303.4 Assembly Group A-3. Group A-3 occupancy includes assembly uses intended for worship, recreation or amusement and other assembly uses not classified elsewhere in Group A including, but not limited to:

- Amusement arcades
- Art galleries more than 3,000 square feet
- Bowling alleys
- Community halls
- Courtrooms
- Dance halls (not including food or drink consumption)
- Exhibition halls
- Funeral parlors
- Greenhouses for the conservation and exhibition of plants that provide public access.
- Gymnasiums (without spectator seating)
- Indoor *swimming pools* (without spectator seating)
- Indoor tennis courts (without spectator seating)
- Lecture halls
- Libraries
- Museums
- *Places of religious worship*
- Pool and billiard parlors
- Waiting areas in transportation terminals

309.1 Mercantile Group M. Mercantile Group M occupancy includes, among others, the use of a building or structure or a portion thereof for the display and sale of merchandise, and involves stocks of goods, wares or merchandise incidental to such purposes and accessible to the public. Mercantile occupancies shall include, but not be limited to, the following:

- Art galleries 3,000 square feet or less
- Department stores
- Drug stores
- Markets
- Greenhouses for display and sale of plants that provide public access.
- Motor fuel-dispensing facilities
- Retail or wholesale stores
- Sales rooms

G15-18 Part II

IBC: TABLE 1004.5 (IFC[BE] TABLE 1004.5)

Proponent: Micah Chappell, representing City of Seattle (micah.chappell@seattle.gov)

2018 International Building Code

Revise as follows:

**TABLE 1004.5
MAXIMUM FLOOR AREA ALLOWANCES PER OCCUPANT**

FUNCTION OF SPACE	OCCUPANT LOAD FACTOR^a
Accessory storage areas, mechanical equipment room	300 gross
Agricultural building	300 gross
Aircraft hangars	500 gross
Airport terminal	20 gross
Baggage claim	300 gross
Baggage handling	100 gross
Concourse Waiting areas	15 gross
Assembly	11 gross
Gaming floors (keno, slots, etc.)	30 net
Exhibit gallery and museum	
Assembly with fixed seats	See Section 1004.6
Assembly without fixed seats	7 net
Concentrated	5 net
(chairs only—not fixed)	15 net
Standing space	
Unconcentrated (tables and chairs)	
Bowling centers, allow 5 persons for each lane including 15 feet of runway, and for additional areas	7 net
Business areas	150 gross
Concentrated business use areas	See Section 1004.8
Courtrooms—other than fixed seating areas	40 net
Day care	35 net
Dormitories	50 gross
Educational	20 net
Classroom area	50 net
Shops and other vocational room areas	
Exercise rooms	50 gross
Group H-5 fabrication and manufacturing areas	200 gross
Industrial areas	100 gross
Institutional areas	240 gross
Inpatient treatment areas	100 gross
Outpatient areas	120 gross
Sleeping areas	
Kitchens, commercial	200 gross
Library	50 net
Reading rooms	100 gross
Stack area	
Locker rooms	50 gross
Mall buildings—covered and open	See Section 402.8.2
Mercantile	60 gross
<u>Art gallery</u>	<u>30 gross</u>
Storage stock, shipping areas	300 gross
Parking garages	200 gross
Residential	200 gross
Skating rinks, swimming pools	50 gross
Rink and pool	15 gross
Decks	
Stages and platforms	15 net
Warehouses	500 gross

For SI: 1 foot = 304.8 mm, 1 square foot = 0.0929 m².

- a. Floor area in square feet per occupant.

Reason:

Provides limited sized art gallery space occupancy classification and the corresponding occupant load factor alignment in the code with the common business practices of selling artistic wares and goods.

This change will allow small commercial storefronts for retail sales of unique and limited-edition items to patrons browsing displayed works, interacting with sales people and making purchases, to be classified as Mercantile Occupancies. This change is similar in concept to the current small space allowances for an Assembly Occupancy to have a classification as a Business Occupancy.

This change maintains the required standards for hazards associated with the current occupancy classification of A-3 for Art Gallery spaces greater than 3,000 square feet and large Mercantile occupancies.

Cost Impact

The code change proposal will decrease the cost of construction .

This code revision has an anticipated cost benefit to the AHJ and building owners/tenants by a reduction in overall expenditures throughout the entire process of permitting, construction, inspection, and operation of retail type businesses in small spaces where an occupancy classification change is currently required. This revision may also provide a cost benefit to the AHJ by increasing business opportunities for individuals and organizations by reducing or eliminating the cost barriers of substantial alterations in these smaller spaces that are often associated with a change in occupancy classification.

Internal ID: 3402

G16-18

IBC: 202, (New), 202, 306.2, 311.2, 406.2.4, 406.2.5, 406.5.4.1, 406.7.2, 406.8.2, 510.3, TABLE 1607.1

Proponent: James Smith, American Wood Council, representing ICC Region III Code Development Committee (jsmith@awc.org); Edward Lisinski, City of West Allis, WI, representing ICC Region III Code Development Committee (elisinski@westalliswi.gov)

2018 International Building Code

SECTION 202 DEFINITIONS

Add new definition as follows:

LIQUID FUEL OR COMPRESSED GAS POWERED MOTOR VEHICLE A vehicle on wheels or other conveyance system, having its own liquid fuel or compressed gas powered motor to propel the vehicle, and not running on rails or tracks, for use on land, streets or highways, such as an automobile, truck, bus, forklift or similar motor vehicle, and which is manually operated.

Revise as follows:

[BG] OPEN PARKING GARAGE. A structure or portion of a structure with the openings as described in Section 406.5.2 on two or more sides that is used for the parking or storage of private liquid fuel or compressed gas powered motor vehicles as described in Section 406.5.3.

[BG] PRIVATE GARAGE. A building or portion of a building in which liquid fuel or compressed gas powered motor vehicles used by the owner or tenants of the building or buildings on the premises are stored or kept, without provisions for repairing or servicing such vehicles for profit.

[BG] REPAIR GARAGE. A building, structure or portion thereof used for servicing or repairing liquid fuel or compressed gas powered motor vehicles.

SECTION 306 FACTORY GROUP F

306.2 Moderate-hazard factory industrial, Group F-1. Factory industrial uses that are not classified as Factory Industrial F-2 Low Hazard shall be classified as F-1 Moderate Hazard and shall include, but not be limited to, the following:

- Aircraft (manufacturing, not to include repair)
- Appliances
- Athletic equipment
- Automobiles and other liquid fuel or compressed gas powered motor vehicles
- Bakeries
- Beverages: over 16-percent alcohol content
- Bicycles
- Boats
- Brooms or brushes
- Business machines
- Cameras and photo equipment
- Canvas or similar fabric
- Carpets and rugs (includes cleaning)
- Clothing
- Construction and agricultural machinery
- Disinfectants
- Dry cleaning and dyeing
- Electric generation plants

- Electronics
- Engines (including rebuilding)
- Food processing establishments and commercial kitchens not associated with restaurants, cafeterias and similar dining facilities more than 2,500 square feet (232 m²) in area.
- Furniture
- Hemp products
- Jute products
- Laundries
- Leather products
- Machinery
- Metals
- Millwork (sash and door)
- Motion pictures and television filming (without spectators)
- Musical instruments
- Optical goods
- Paper mills or products
- Photographic film
- Plastic products
- Printing or publishing
- Recreational vehicles
- Refuse incineration
- Shoes
- Soaps and detergents
- Textiles
- Tobacco
- Trailers
- Upholstering
- Wood; distillation
- Woodworking (cabinet)

311.2 Moderate-hazard storage, Group S-1. Storage Group S-1 occupancies are buildings occupied for storage uses that are not classified as Group S-2, including, but not limited to, storage of the following:

- Aerosol products, Levels 2 and 3
- Aircraft hangar (storage and repair)
- Bags: cloth, burlap and paper
- Bamboos and rattan
- Baskets
- Belting: canvas and leather
- Books and paper in rolls or packs
- Boots and shoes
- Buttons, including cloth covered, pearl or bone
- Cardboard and cardboard boxes
- Clothing, woolen wearing apparel
- Cordage
- Dry boat storage (indoor)

- Furniture
- Furs
- Glues, mucilage, pastes and size
- Grains
- Horns and combs, other than celluloid
- Leather
- Linoleum
- Lumber
- ~~Motor~~ Liquid fuel or compressed gas powered motor vehicle repair garages complying with the maximum allowable quantities of hazardous materials listed in Table 307.1(1) (see Section 406.8)
- Photo engravings
- Resilient flooring
- Self-service storage facility (mini-storage)
- Silks
- Soaps
- Sugar
- Tires, bulk storage of
- Tobacco, cigars, cigarettes and snuff
- Upholstery and mattresses
- Wax candles

406.2.4 Floor surfaces. Floor surfaces shall be of concrete or similar approved noncombustible and nonabsorbent materials. The area of floor used for the parking of ~~automobiles or other~~ liquid fuel or compressed gas powered motor vehicles shall be sloped to facilitate the movement of liquids to a drain or toward the main vehicle entry doorway. The surface of vehicle fueling pads in motor fuel-dispensing facilities shall be in accordance with Section 406.7.1.

Exceptions:

1. Asphalt parking surfaces shall be permitted at ground level for public parking garages and private carports.
2. Floors of Group S-2 parking garages shall not be required to have a sloped surface.
3. Slip-resistant, nonabsorbent, interior floor finishes having a critical radiant flux not more than 0.45 W/cm², as determined by ASTM E648 or NFPA 253, shall be permitted in repair garages.

406.2.5 Sleeping rooms. Openings between a liquid fuel or compressed gas powered motor vehicle-related occupancy and a room used for sleeping purposes shall not be permitted.

406.5.4.1 Single use. Where the *open parking garage* is used exclusively for the parking or storage of private liquid fuel or compressed gas powered motor vehicles, and the building is without other uses, the area and height shall be permitted to comply with Table 406.5.4, along with increases allowed by Section 406.5.5.

Exception: The grade-level tier is permitted to contain an office, waiting and toilet rooms having a total combined area of not more than 1,000 square feet (93 m²). Such area need not be separated from the *open parking garage*.

In *open parking garages* having a spiral or sloping floor, the horizontal projection of the structure at any cross section shall not exceed the allowable area per parking tier. In the case of an *open parking garage* having a continuous spiral floor, each 9 feet 6 inches (2896 mm) of height, or portion thereof, shall be considered under these provisions to be a tier.

406.7.2 Canopies. Canopies under which fuels are dispensed shall have a clear, unobstructed height of not less than 13 feet 6 inches (4115 mm) to the lowest projecting element in the vehicle drive-through area. Canopies and their supports over pumps shall be of noncombustible materials, *fire-retardant-treated wood* complying with Chapter 23, heavy timber complying with Section 2304.11 or construction providing 1-hour *fire resistance*. Combustible materials used in or on a *canopy* shall comply with one of the following:

1. Shielded from the pumps by a noncombustible element of the *canopy*, or heavy timber complying

with Section 2304.11.

2. Plastics covered by aluminum facing having a thickness of not less than 0.010 inch (0.30 mm) or corrosion-resistant steel having a base metal thickness of not less than 0.016 inch (0.41 mm). The plastic shall have a *flame spread index* of 25 or less and a smoke-developed index of 450 or less when tested in the form intended for use in accordance with ASTM E84 or UL 723 and a self-ignition temperature of 650°F (343°C) or greater when tested in accordance with ASTM D1929.
3. Panels constructed of light-transmitting plastic materials shall be permitted to be installed in *canopies* erected over liquid fuel or compressed gas powered motor vehicle fuel-dispensing station fuel dispensers, provided that the panels are located not less than 10 feet (3048 mm) from any building on the same *lot* and face *yards* or streets not less than 40 feet (12 192 mm) in width on the other sides. The aggregate areas of plastics shall be not greater than 1,000 square feet (93 m²). The maximum area of any individual panel shall be not greater than 100 square feet (9.3 m²).

[F] 406.8.2 Gas detection system. Repair garages used for repair of liquid fuel or compressed gas powered motor vehicles fueled by nonodorized gases including but not limited to hydrogen and nonodorized LNG, shall be provided with a gas detection system that complies with Section 916. The gas detection system shall be designed to detect leakage of nonodorized gaseous fuel. Where lubrication or chassis service pits are provided in garages used for repairing nonodorized LNG-fueled vehicles, gas sensors shall be provided in such pits.

510.3 Group S-2 enclosed parking garage with Group S-2 open parking garage above. A Group S-2 enclosed parking garage with not more than one *story above grade plane* and located below a Group S-2 open *parking garage* shall be classified as a separate and distinct building for the purpose of determining the type of construction where all of the following conditions are met:

1. The allowable area of the building shall be such that the sum of the ratios of the actual area divided by the allowable area for each separate occupancy shall not exceed 1.
2. The Group S-2 enclosed parking garage is of Type I or II construction and is at least equal to the *fire-resistance* requirements of the Group S-2 *open parking garage*.
3. The height and the number of tiers of the Group S-2 *open parking garage* shall be limited as specified in Table 406.5.4.
4. The floor assembly separating the Group S-2 enclosed parking garage and Group S-2 *open parking garage* shall be protected as required for the floor assembly of the Group S-2 enclosed parking garage. Openings between the Group S-2 enclosed parking garage and Group S-2 *open parking garage*, except *exit* openings, shall not be required to be protected.
5. The Group S-2 enclosed parking garage is used exclusively for the parking or storage of private liquid fuel or compressed gas powered motor vehicles, but shall be permitted to contain an office, waiting room and toilet room having a total area of not more than 1,000 square feet (93 m²) and mechanical equipment rooms incidental to the operation of the building.

TABLE 1607.1

MINIMUM UNIFORMLY DISTRIBUTED LIVE LOADS, L_0 , AND MINIMUM CONCENTRATED LIVE LOADS⁹

Portions of table not shown remain unchanged.

For SI: 1 inch = 25.4 mm, 1 square inch = 645.16 mm²,
1 square foot = 0.0929 m²,
1 pound per square foot = 0.0479 kN/m², 1 pound = 0.004448 kN,
1 pound per cubic foot = 16 kg/m³.

- a. Floors in garages or portions of buildings used for the storage of liquid fuel or compressed gas powered motor vehicles shall be designed for the uniformly distributed live loads of this table or the following concentrated loads: (1) for garages restricted to passenger vehicles accommodating not more than nine passengers, 3,000 pounds acting on an area of 4¹/₂ inches by 4¹/₂ inches; (2) for mechanical parking structures without slab or deck that are used for storing passenger vehicles only, 2,250 pounds per wheel.
- b. The loading applies to stack room floors that support nonmobile, double-faced library book stacks, subject to the following limitations:
 1. The nominal book stack unit height shall not exceed 90 inches.
 2. The nominal shelf depth shall not exceed 12 inches for each face.
 3. Parallel rows of double-faced book stacks shall be separated by aisles not less than 36 inches wide.
- c. Design in accordance with ICC 300.
- d. Other uniform loads in accordance with an approved method containing provisions for truck loadings shall be considered where appropriate.
- e. The concentrated wheel load shall be applied on an area of 4.5 inches by 4.5 inches.
- f. The minimum concentrated load on stair treads shall be applied on an area of 2 inches by 2 inches. This load need not be assumed to act concurrently with the uniform load.
- g. Where snow loads occur that are in excess of the design conditions, the structure shall be designed to support the loads due to the increased loads caused by drift buildup or a greater snow design determined by the building official (see Section 1608).
- h. See Section 1604.8.3 for decks attached to exterior walls.
- i. Uninhabitable attics without storage are those where the maximum clear height between the joists and rafters is less than 42 inches, or where there are not two or more adjacent trusses with web configurations capable of accommodating an assumed rectangle 42 inches in height by 24 inches in width, or greater, within the plane of the trusses. This live load need not be assumed to act concurrently with any other live load requirements.
- j. Uninhabitable attics with storage are those where the maximum clear height between the joists and rafters is 42 inches or greater, or where there are two or more adjacent trusses with web configurations capable of accommodating an assumed rectangle 42 inches in height by 24 inches in width, or greater, within the plane of the trusses.

The live load need only be applied to those portions of the joists or truss bottom chords where both of the following conditions are met:

 - i. The attic area is accessible from an opening not less than 20 inches in width by 30 inches in length that is located where the clear height in the attic is not less than 30 inches.
 - ii. The slopes of the joists or truss bottom chords are not greater than two units vertical in 12 units horizontal.

The remaining portions of the joists or truss bottom chords shall be designed for a uniformly distributed concurrent live load of not less than 10 pounds per square foot.
- k. Attic spaces served by stairways other than the pull-down type shall be designed to support the minimum live load specified for habitable attics and sleeping rooms.
- l. Areas of occupiable roofs, other than roof gardens and assembly areas, shall be designed for appropriate loads as approved by the building official. Unoccupied landscaped areas of roofs shall be designed in accordance with Section 1607.13.3.
- m. Live load reduction is not permitted.
- n. Live load reduction is only permitted in accordance with Section 1607.11.1.2 or Item 1 of Section 1607.11.2.

- o. Live load reduction is only permitted in accordance with Section 1607.11.1.3 or Item 2 of Section 1607.11.2.

Reason:

A similar code change proposal was submitted for a definition of a Motor Vehicle. While researching this code change proposal, we determined that most code sections relative to motor vehicles could be broken down into three categories:

1. Code sections dealing with impact protection from operator error.
2. Code sections dealing with fumes related to fuel vapor accumulation related to internal combustion engines that are not being operated.
3. Code sections dealing with fumes related to combustion of the internal combustion engines being operated (exhaust).

We felt that a second definition may help to separate the three issues and bring more clarity into what the issue is with a motor vehicle in each situation. We tried to apply the logic that if the code section is still relevant if the vehicle used is a fully electric golf cart or forklift, then it belongs with all Motor Vehicles...but if the code section only applies if the vehicle is emitting exhaust or fumes from the internal combustion engine, then it would fall into this second proposed definition.

We tried to identify all of the code sections in the IBC where we felt this separate definition would be appropriate. There may be additional reasons to use this definition in the IMC or IFC, but for this code change proposal, we did not pursue those at this time. We feel that each section identified would not make sense if the vehicle described is an electric golf cart or forklift which produces no or minimal exhaust or fumes.

Cost Impact

The code change proposal will not increase or decrease the cost of construction .

The additional definition is only being provided to assist users of the code when confronted by those code sections that regulate Motor Vehicles, and help to define which types of motor vehicles need to be regulated by each code section. There are no added regulatory provisions.

Internal ID: 2046

G17-18

IBC: 306.2

Proponent: Ed Kullik, Chair, representing ICC Building Code Action Committee (bcac@iccsafe.org); Robert Davidson, Davidson Code Concepts, LLC, representing Tesla, USA (rjd@davidsoncodeconcepts.com)

2018 International Building Code

Revise as follows:

306.2 Moderate-hazard factory industrial, Group F-1. Factory industrial uses that are not classified as Factory Industrial F-2 Low Hazard shall be classified as F-1 Moderate Hazard and shall include, but not be limited to, the following:

- Aircraft (manufacturing, not to include repair)
- Appliances
- Athletic equipment
- Automobiles and other motor vehicles
- Bakeries
- Beverages: over 16-percent alcohol content
- Bicycles
- Boats
- Brooms or brushes
- Business machines
- Cameras and photo equipment
- Canvas or similar fabric
- Carpets and rugs (includes cleaning)
- Clothing
- Construction and agricultural machinery
- Disinfectants
- Dry cleaning and dyeing
- Electric generation plants
- Electronics
- Energy storage systems (ESS) in dedicated use buildings
- Engines (including rebuilding)
- Food processing establishments and commercial kitchens not associated with restaurants, cafeterias and similar dining facilities more than 2,500 square feet (232 m²) in area.
- Furniture
- Hemp products
- Jute products
- Laundries
- Leather products
- Machinery
- Metals
- Millwork (sash and door)
- Motion pictures and television filming (without spectators)
- Musical instruments
- Optical goods
- Paper mills or products

- Photographic film
- Plastic products
- Printing or publishing
- Recreational vehicles
- Refuse incineration
- Shoes
- Soaps and detergents
- Textiles
- Tobacco
- Trailers
- Upholstering
- Wood; distillation
- Woodworking (cabinet)

Reason:

This proposal is a correlation issue with the FCAC IFC Section 1206 ESS rewrite. The FCAC looked at the hazards associated with dedicated use utility type ESS installations covered under the following section and decided that Group F-1 was an appropriate classification. For the most part they will serve the grid scale areas of ESS deployment and large facilities.

(IFC) 1206.7.2 Dedicated use buildings. For the purpose of Table 1206.7 dedicated use ESS buildings shall be classified as Group F-1 occupancies and comply with all the following.

The building shall only be used for ESS, electrical energy generation, and other electrical grid related operations.

Occupants in the rooms and areas containing ESS are limited to personnel that operate, maintain, service, test and repair the ESS and other energy systems.

No other occupancy types shall be permitted in the building.

Administrative and support personnel shall be permitted in areas within the buildings that do not contain ESS, provided:

The areas do not occupy more than 10 percent of the building area of the story in which they are located.

A means of egress is provided from the incidental use areas to the public way that does not require occupants to traverse through areas containing ESS or other energy system equipment.

(Also the administrative support areas are separated from the ESS by a 2 hour fire separation.)

When looking at the group classifications and expected fuel loads the F-1 fits the ESS Dedicated Use Building from that standpoint, especially since Electric Generation Plants are already an F-1 Group. ESS are part of the overall electric generation and storage. If ESS is installed in a building occupied by another group it will remain that Group and be required to have the increased fire protection features for the space the ESS occupies. That does not change from how the current code addresses ESS.

This proposal is submitted by the ICC Building Code Action Committee (BCAC). BCAC was established by the ICC Board of Directors in July 2011 to pursue opportunities to improve and enhance assigned International Codes or portions thereof. In 2017 the BCAC has held 3 open meetings. In addition, there were numerous Working Group meetings and conference calls for the current code development cycle, which included members of the committee as well as any interested party to discuss and debate the proposed changes. Related documentation and reports are posted on the BCAC website at: <https://www.iccsafe.org/codes-tech-support/codes/code-development-process/building-code-action-committee-bcac>.

Cost Impact

The code change proposal will decrease the cost of construction .

This proposal provides correlation with an IFC proposal. The IFC proposal will actually decrease the cost of construction because it will allow larger ESS installations in dedicated use indoor locations to be in Group F-1 occupancies, rather than in H-2 occupancies.

G18-18

IBC: 306.3

Proponent: Stephen Thomas, Colorado Code Consulting, LLC, representing Colorado Chapter ICC (sthomas@coloradocode.net)

2018 International Building Code

Revise as follows:

306.3 Low-hazard factory industrial, Group F-2. Factory industrial uses that involve the fabrication or manufacturing of noncombustible materials that during finishing, packing or processing do not involve a significant fire hazard shall be classified as F-2 occupancies and shall include, but not be limited to, the following:

- Beverages: up to and including 16-percent alcohol content
- Brick and masonry
- Ceramic products
- Foundries
- Glass products
- Gypsum
- Ice
- Metal products (fabrication and assembly)
- Water/sewer treatment facilities

Reason:

Just about every jurisdiction has a water or sewer treatment facility in them. However, many people have difficulty determining the occupancy classification. Therefore, we are proposing that these uses be added to the Group F-2 Occupancy list. These facilities are a low hazard occupancy with the exception of some hazardous materials used in the processing. The code has provisions to handle the use of these hazardous materials. The proposal provides users a clear classification of these facilities and makes it easier to use.

Cost Impact

The code change proposal will not increase or decrease the cost of construction .

This is a clarification of the code requirements.

Internal ID: 240

G19-18

IBC: SECTION [F]307.4, [F]307.5

Proponent: Robert Davidson, Davidson Code Concepts, LLC, representing Self (rjd@davidsoncodeconcepts.com)

THIS CODE CHANGE WILL BE HEARD BY THE FIRE CODE COMMITTEE. SEE THE TENTATIVE HEARING ORDER FOR THIS COMMITTEE

2018 International Building Code

SECTION 307 HIGH-HAZARD GROUP H

[F] 307.1 High-hazard Group H. High-hazard Group H occupancy includes, among others, the use of a building or structure, or a portion thereof, that involves the manufacturing, processing, generation or storage of materials that constitute a physical or health hazard in quantities in excess of those allowed in *control areas* complying with Section 414, based on the maximum allowable quantity limits for *control areas* set forth in Tables 307.1(1) and 307.1(2). Hazardous occupancies are classified in Groups H-1, H-2, H-3, H-4 and H-5 and shall be in accordance with this section, the requirements of Section 415 and the International Fire Code. Hazardous materials stored, or used on top of roofs or canopies, shall be classified as outdoor storage or use and shall comply with the International Fire Code.

Revise as follows:

[F] 307.4 High-hazard Group H-2. Buildings and structures containing materials that pose a deflagration hazard or a hazard from accelerated burning shall be classified as Group H-2. Such materials shall include, but not be limited to, the following:

- Class I, II or IIIA flammable or combustible liquids that are used or stored in normally open containers or systems, or in closed containers or systems pressurized at more than 15 pounds per square inch gauge (103.4 kPa).
- Combustible dusts where manufactured, generated or used in such a manner that the concentration and conditions create a fire or explosion hazard based on ~~information~~ a dust hazard analysis prepared in accordance with Section ~~414.1.3.426.1~~ and NFPA 652.
- Cryogenic fluids, flammable.
- Flammable gases.
- Organic peroxides, Class I.
- Oxidizers, Class 3, that are used or stored in normally open containers or systems, or in closed containers or systems pressurized at more than 15 pounds per square inch gauge (103 kPa).
- Pyrophoric liquids, solids and gases, nondetonable.
- Unstable (reactive) materials, Class 3, nondetonable.
- Water-reactive materials, Class 3.

[F] 307.5 High-hazard Group H-3. Buildings and structures containing materials that readily support combustion or that pose a physical hazard shall be classified as Group H-3. Such materials shall include, but not be limited to, the following:

- Class I, II or IIIA flammable or combustible liquids that are used or stored in normally closed containers or systems pressurized at 15 pounds per square inch gauge (103.4 kPa) or less.
- Combustible fibers, other than densely packed baled cotton, where manufactured, generated or used in such a manner that the concentration and conditions create a fire or explosion hazard based on ~~information~~ a dust hazard analysis prepared in accordance with Section ~~414.1.3.426.1~~ and NFPA 652.
- Consumer fireworks, 1.4G (Class C, Common)
- Cryogenic fluids, oxidizing
- Flammable solids
- Organic peroxides, Class II and III
- Oxidizers, Class 2
- Oxidizers, Class 3, that are used or stored in normally closed containers or systems pressurized at 15

pounds per square inch gauge (103 kPa) or less

- Oxidizing gases
- Unstable (reactive) materials, Class 2
- Water-reactive materials, Class 2

Reason:

This proposal is follow up work correlating the IBC and IFC provisions with the work done on Chapter 22 Combustible Dust and Chapter 37 Combustible Fibers in the IFC along with Section 426 of the IBC.

With the addition of NFPA 652 specific requirements are now applicable on how to perform a Dust Hazard Analysis for the purpose of characterizing a dust hazard and identifying building or operational features that need to be addressed to properly manage the hazard.

This proposal points the Combustible Dust and Combustible Fibers hazard classification language to the appropriate standard for developing the necessary information for submittal to the code official. A key hazard of combustible fibers within a building in addition to the fibers is a dust hazard and Chapter 37 Combustible Fibers in the IFC is linked to Chapter 22 Combustible Dust-Producing Operations already at Section 3703.5.

Both IBC Section 426.1 and Chapter 22 of the IFC apply NFPA 652 as the primary standard. Chapter 7 of NFPA 652 contains the requirements for conducting a Dust Hazard Analysis.

By modifying the language it will assist designers and code officials by ensuring a detailed analysis is performed providing information relevant to the specific hazards.

Cost Impact

The code change proposal will not increase or decrease the cost of construction .

This proposal is a correlation based upon updated provisions in the codes. The cost impact should be neutral, though any time the language is improved there is a potential to eliminate unnecessary costs.

Internal ID: 1567

G20-18

IBC: [F] 307.4, [F] 307.5

Proponent: Robert Davidson, Davidson Code Concepts, LLC, representing Self (rjd@davidsoncodeconcepts.com)

THIS CODE CHANGE WILL BE HEARD BY THE FIRE CODE COMMITTEE. SEE THE TENTATIVE HEARING ORDER FOR THIS COMMITTEE

2018 International Building Code

[F] 307.1 High-hazard Group H. High-hazard Group H occupancy includes, among others, the use of a building or structure, or a portion thereof, that involves the manufacturing, processing, generation or storage of materials that constitute a physical or health hazard in quantities in excess of those allowed in *control areas* complying with Section 414, based on the maximum allowable quantity limits for *control areas* set forth in Tables 307.1(1) and 307.1(2). Hazardous occupancies are classified in Groups H-1, H-2, H-3, H-4 and H-5 and shall be in accordance with this section, the requirements of Section 415 and the International Fire Code. Hazardous materials stored, or used on top of roofs or canopies, shall be classified as outdoor storage or use and shall comply with the International Fire Code.

Revise as follows:

[F] 307.4 High-hazard Group H-2. Buildings and structures containing materials that pose a deflagration hazard or a hazard from accelerated burning shall be classified as Group H-2. Such materials shall include, but not be limited to, the following:

- Class I, II or IIIA flammable or combustible liquids that are used or stored in normally open containers or systems, or in closed containers or systems pressurized at more than 15 pounds per square inch gauge (103.4 kPa).
-
- ~~Combustible dusts where manufactured, generated or used in such a manner that the concentration and conditions create a fire or explosion hazard based on information prepared in accordance with Section 414.1.3.~~
Cryogenic fluids, flammable.
- Flammable gases.
- Organic peroxides, Class I.
- Oxidizers, Class 3, that are used or stored in normally open containers or systems, or in closed containers or systems pressurized at more than 15 pounds per square inch gauge (103 kPa).
- Pyrophoric liquids, solids and gases, nondetonable.
- Unstable (reactive) materials, Class 3, nondetonable.
- Water-reactive materials, Class 3.

[F] 307.5 High-hazard Group H-3. Buildings and structures containing materials that readily support combustion or that pose a physical hazard shall be classified as Group H-3. Such materials shall include, but not be limited to, the following:

- Class I, II or IIIA flammable or combustible liquids that are used or stored in normally closed containers or systems pressurized at 15 pounds per square inch gauge (103.4 kPa) or less.
-
- ~~Combustible fibers, other than densely packed baled cotton, where manufactured, generated or used in such a manner that the concentration and conditions create a fire or explosion hazard based on information prepared in accordance with Section 414.1.3.~~
Consumer fireworks, 1.4G (Class C, Common)
- Cryogenic fluids, oxidizing
- Flammable solids
- Organic peroxides, Class II and III
- Oxidizers, Class 2

- Oxidizers, Class 3, that are used or stored in normally closed containers or systems pressurized at 15 pounds per square inch gauge (103 kPa) or less
- Oxidizing gases
- Unstable (reactive) materials, Class 2
- Water-reactive materials, Class 2

Reason:

This proposal is follow up work correlating the IBC and IFC provisions with the work done on Chapter 22 Combustible Dust and Chapter 37 Combustible Fibers in the IFC along with Section 426 of the IBC.

The proposal seeks to delete the listing of dust and combustible fibers from IBC Table 307.1(1) and IFC Table 5003.1.1(1).

The key reason for deleting the listings is because combustible dust is typically not a hazardous material, a small percentage may be, but the dust hazard classification is not a hazardous material issue. The same for combustible fibers.

2018 IBC

“SECTION 307 HIGH-HAZARD GROUP H

[F] 307.1 High-hazard Group H. High-hazard Group H occupancy includes, among others, the use of a building or structure, or a portion thereof, that involves the manufacturing, processing, generation or storage of materials that constitute a physical or health hazard in quantities in excess of those allowed in control areas complying with Section 414, based on the maximum allowable quantity limits for control areas set forth in Tables 307.1(1) and 307.1(2). Hazardous occupancies are classified in Groups H-1, H-2, H-3, H-4 and H-5 and shall be in accordance with this section, the requirements of Section 415 and the International Fire Code. Hazardous materials stored, or used on top of roofs or canopies, shall be classified as outdoor storage or use and shall comply with the International Fire Code.”

“[F] HAZARDOUS MATERIALS. Those chemicals or substances that are physical hazards or health hazards as classified in Section 307 and the International Fire Code, whether the materials are in usable or waste condition.”

“[F] HEALTH HAZARD. A classification of a chemical for which there is statistically significant evidence that acute or chronic health effects are capable of occurring in exposed persons. The term “health hazard” includes chemicals that are toxic or highly toxic, and corrosive.”

“[F] PHYSICAL HAZARD. A chemical for which there is evidence that it is a combustible liquid, cryogenic fluid, explosive, flammable (solid, liquid or gas), organic peroxide (solid or liquid), oxidizer (solid or liquid), oxidizing gas, pyrophoric (solid, liquid or gas), unstable (reactive) material (solid, liquid or gas) or water-reactive material (solid or liquid).”

By scoping and definition, Section 307 applies to hazardous materials, chemicals. Combustible dust and combustible fiber hazards are not hazardous material or chemical hazards. So, in applying Section 307 on H Group occupancies you can only apply the requirements to those combustible dusts or combustible fibers that also happen to be chemicals.

The need for the hazardous group listings has been eliminated by work last cycle to update the combustible dust requirements of the code. Combustible fiber language was updated going into the 2015 IFC and that chapter points to the combustible dust chapter.

Previously there appeared to be an option to not mitigate a dust/fiber fire explosion hazard and default to an H Group Occupancy. That is no longer permitted. A facility, new or existing, must test to identify the hazard and then must take measures to manage the hazard.

2018 IBC

“SECTION [F] 426 COMBUSTIBLE DUSTS, GRAIN PROCESSING AND STORAGE

[F] 426.1 General. The provisions of Sections 426.1.1 through 426.1.7 shall apply to buildings in which materials that produce combustible dusts are stored or handled. Buildings that store or handle combustible dusts shall comply with NFPA 652 and the applicable provisions of NFPA 61, NFPA 85, NFPA 120, NFPA 484, NFPA 654, NFPA 655 and NFPA 664 and the International Fire Code.”

“2018 IFC

SECTION 2201

GENERAL 2201.1 Scope. The equipment, processes and operations involving dust explosion hazards shall comply with the provisions of this code and NFPA 652.”

“SECTION 2203 PRECAUTIONS

2203.1 Owner responsibility. The owner or operator of a facility with operations that manufacture, process, blend, convey, repackage, generate or handle potentially combustible dust or combustible particulate solids shall be responsible for compliance with the provisions of this code and NFPA 652.2203.2 Dust hazard analysis (DHA). The requirements of NFPA 652 apply to all new and existing facilities and operations with combustible dust hazard. Existing facilities shall have a dust hazard analysis (DHA) completed in accordance with Section 7.1.2 of NFPA 652.

The fire code official shall be authorized to order a dust hazard analysis to occur sooner if a combustible dust hazard has been identified in a facility that has not previously performed an analysis."

With the addition of the new NFPA 652 Standard on the Fundamentals of Combustible Dust as a core requirement in both the IBC and the IFC, currently written the code now requires the identified hazard to be addressed whether in a new or existing facility. This makes a H-2 or H-3 Group designation moot.

The activities will be designated appropriately as an F-1 or an S-1. Several occupancies currently listed in Groups F-1 and S-1 are occupancies that have material that require the assessment of the hazard presented.

During drafting of the proposal it was argued that the H-2 and H-3 classifications must remain because they are needed for a potential deflagration even though the codes now require the hazard to be managed because a deflagration could occur in case something goes wrong, or the code is not followed. The claim is that the H Group is a fail safe requirement. This argument is not supported by current code provisions where activities are not classified as high hazard currently in addition to the fact that the combustible dust hazards and combustible fiber hazards are not regulated by the scoping of Section 307 of the IBC or Chapter 50 of the IFC.

Section [F] 307.1.1 Uses other than Group H of the IBC has a laundry list of activities that are not to be classified as a Group H provided they comply with the codes otherwise that could present deflagration hazards if something goes wrong or the code is not complied with.

"1. Buildings and structures occupied for the application of flammable finishes, provided that such buildings or areas conform to the requirements of Section 416 and the International Fire Code."

A major hazard of flammable finishes is a deflagration. In many finish application activities you are creating the hazard by volatilizing the product. This is addressed through engineering controls and ignition hazard controls and in exchange for those code required controls they are not classified as an H-2 in case things go wrong or the code is not followed. The assumption is that the code will be followed.

"3. Closed piping system containing flammable or combustible liquids or gases utilized for the operation of machinery or equipment."

If the material is enclosed in piping we automatically exclude the H Group regardless of amounts present. Even though we know a leak can cause a deflagration hazard, (and has). We assume code compliance addresses the safety issues.

"7. Refrigeration systems."

Even if the systems utilize flammable gas as a refrigerant, (actually this exception is because of the use of flammable gas as a refrigerant), which will cause a deflagration hazard if they leak. (And there have been deflagrations). The assumption is that the code will be followed.

"14. The storage of black powder, smokeless propellant and small arms primers in Groups M and R-3 and special industrial explosive devices in Groups B, F, M and S, provided such storage conforms to the quantity limits and requirements prescribed in the International Fire Code."

Again, we assume code compliance addresses the hazard.

Laboratories are a Group B even though they can have flammable gases or liquids present sufficient to cause a deflagration hazard if released.

The quantities of materials in Tables 5003.1.1(1) and IBC Table 307.1(1) do not consider deflagration potentials. If they did, the amount of material permitted would be tied directly to the size of the space and additional levels of protection for even the smallest amounts.

Based upon analysis, a single-family garage can be destroyed by a cup of gasoline that is fully volatilized and an ignition source is introduced. Yet we permit up to 30 gallons of flammable liquid to be present in any occupancy under the MAQ tables, 60 gallons if we provide sprinkler protection even though sprinkler protection has nothing to do with preventing a deflagration or mitigating its effects other than the post fire event potential. The fire code allows flammable liquid quantities beyond that needed for a deflagration to occur even in residential occupancies.

2018 IFC

"5704.3.4.2 Occupancy quantity limits. The following limits for quantities of stored flammable or combustible liquids shall not be exceeded:...

7. Group R occupancies: Quantities in Group R occupancies shall not exceed that necessary for maintenance purposes and operation of equipment, and shall not exceed quantities set forth in Table 5003.1.1(1)."

The same analogy can be used for the amount flammable gases permitted in a given space.

The removal of the H Group designations removes language that cannot be applied in most cases because the combustible dust or combustible fiber is not a hazardous material or chemical.

Cost Impact

The code change proposal will decrease the cost of construction .

This proposal recognizes improvement of the language in the IBC and IFC that occurred the last two cycles addressing the hazards presented by these activities. The net effect would be that a reduction is possible anytime the code is clarified and correlated eliminating unnecessary designations.

Internal ID: 1557

G21-18

IBC: 310.2

Proponent: Daniel Willham, County of Fairfax, Virginia, representing Virginia Building and Code Officials Association (VBCOA) (daniel.willham@fairfaxcounty.gov)

2018 International Building Code

Revise as follows:

310.2 Residential Group R-1. Residential Group R-1 occupancies containing *sleeping units* or more than two dwelling units where the occupants are primarily *transient* in nature, including:

- *Boarding houses (transient)* with more than 10 occupants
- *Congregate living facilities (transient)* with more than 10 occupants
- *Hotels (transient)*
- *Motels (transient)*

Reason:

There appears to be a gap in the code for hotels (transient) that provide dwelling units. As currently written, neither the R-1 nor the R-2 descriptions provide clear direction on the classification of hotels (transient) that provide dwelling units. The commentary clarifies that R-1 occupancies can contain either sleeping units, dwelling units, or both, but the code as written does not explicitly address transient residential occupancies that contain (more than two) dwelling units. The key characteristic of group R-1 occupancies is the transient nature of the occupants and not the absence of dwelling units. This proposal simply adds language for dwelling units that mirrors that used in the description of R-2 non-transient occupancies. With this clarification, the difference between R-1 and R-2 occupancies will be clearly defined to depend only on the transient or non-transient nature of the occupants, respectively. For reference, an excerpt from the IBC commentary (pg3-37) follows this change proposal.

living facilities are also classified as Group R. Specifically, these facilities are classified as Group R-4. Mainstreaming people who are recovering from alcohol or drug addiction and people who are developmentally disabled is reported to have therapeutic and social benefits. A residential environment often fosters this mainstreaming.

A building or part of a building is considered to be a residential occupancy if it is intended to be used for sleeping accommodations (including assisted living facilities) and is not an institutional occupancy. Institutional occupancies are similar to residential occupancies in many ways. However, they differ from each other in that institutional occupants are in a supervised environment, and, in the case of Groups I-2 and I-3 occupancies, are under some form of restraint or physical limitation that makes them incapable of complete self-preservation. The number of these occupants who are under supervision or are incapable of self-preservation is one distinguishing factor for being classified as an institutional or residential occupancy.

The term Group R refers collectively to the four individual residential occupancy classifications: Groups R-1, R-2, R-3 and R-4. These classifications are differentiated in the code based on the following criteria: 1. Whether the occupants are transient or nontransient in nature; 2. The type and number of dwelling units or sleeping units contained in a single building; and 3. The number of occupants in the facility.

310.2 Definitions. The following terms are defined in Chapter 2:

BOARDING HOUSE.
CONGREGATE LIVING FACILITIES.
DORMITORY.
GROUP HOME.
GUEST ROOM.
LODGING HOUSE.
PERSONAL CARE SERVICE.
TRANSIENT.

◆ This section lists terms that are specifically associated with the subject matter of this section. It is important to emphasize that these terms are not exclusively related to this section but may or may not also be applicable where the term is used elsewhere in the code.

Definitions of terms can help in the understanding and application of the code requirements. The purpose for including a list within this chapter is to provide more convenient access to terms which may have a specific or limited application within this chapter. For the complete definition and associated commentary, refer back to Chapter 2. Terms that are italicized provide a visual identification throughout the code that a definition exists for that term. The use and

application of all defined terms are set forth in Section 201.

310.3 Residential Group R-1. Residential Group R-1 occupancies containing sleeping units whose the occupants are primarily transient in nature, including:

Boarding houses (transient) with more than 10 occupants
Congregate living facilities (transient) with more than 10 occupants
Hotels (transient)
Motels (transient)

◆ The key characteristic of Group R-1 that differentiates it from other Group R occupancies is that the occupants are considered transient in nature (i.e., those whose length of stay is not more than 30 days). There is an expectation that the occupants are not as familiar with the building as those residents in nontransient facilities such as apartment buildings and single-family dwellings. If occupants are unfamiliar with their surroundings, they may not recognize potential hazards or be able to use the means of egress effectively.

The most common building types classified in Group R-1 are hotels, motels and boarding houses. Facilities classified as Group R-1 occupancies may include dwelling units, sleeping units, or a combination of both. Group R-1 occupancies do not typically have cooking facilities in the unit. When a unit is not equipped with cooking facilities, it does not meet the definition of a "dwelling unit" in Section 202. When this occurs, such units are treated as sleeping units for the application of code provisions (see Commentary Figure 310.3). A recent trend in development is the construction of "extended-stay hotels." While these units may have all of the characteristics of a typical dwelling unit (i.e., cooking, living, sleeping, eating, sanitation), the length of stay is still typically not more than 30 days. As such, these buildings would still be classified as Group R-1. If the length of stay is more than 30 days, these buildings would be classified as Group R-2. If a hotel offers rooms for short-term housing (i.e., more than 30 days), the facility must comply with the provisions for both Groups R-1 and R-2 (see Section 302.1).

Other occupancies are often found in buildings classified in Group R-1. These occupancies include nightclubs (Group A-2), restaurants (Group A-2), gift shops (Group M), business offices (Group B), health clubs (Group A-3) and storage facilities (Group S-1). When this occurs, the building is a mixed occupancy and is subject to the provisions of Section 508.

Transient congregate living facilities and boarding houses with 10 or fewer occupants can be constructed to the standards of Group R-3 occupancies rather than the general category of Group R-1. The primary intent of this provision is to permit bed-and-breakfast-type facilities to be established in existing single-family (one-family) structures. In comparison to the provision under Group R-2 which permits congregate living facilities with fewer than 16 nontransient

Bibliography:

2015 IBC Code and Commentary, Volume 1, International Code Council, 2015, pg. 3-37.

Cost Impact

The code change proposal will not increase or decrease the cost of construction .

This is a clarification which will not affect construction cost.

Internal ID: 1049

G22-18

IBC: 310.4.2

Proponent: Jeffrey Shapiro, representing IRC Fire Sprinkler Coalition (jeff.shapiro@intlcodeconsultants.com)

2018 International Building Code

Revise as follows:

310.4.1 Care facilities within a dwelling. Care facilities for five or fewer persons receiving care that are within a single-family dwelling are permitted to comply with the International Residential Code provided an *automatic sprinkler system* is installed in accordance with Section 903.3.1.3 or Section P2904 of the International Residential Code.

310.4.2 Lodging houses. Owner-occupied *lodging houses* with five or fewer *guest rooms* and 10 or fewer total occupants shall be permitted to be constructed in accordance with the International Residential Code provided an automatic sprinkler system is installed in accordance with Section 903.3.1.3 or Section P2904 of the International Residential Code.

Reason:

Correlation with the format of Section 310.5.1 (which is shown without change for reference) and IRC Section 101.2 Exception 2. Application of 310.5.1 and 310.5.2 with respect to the IRC reference is identical, and it makes not sense for one section to properly include the correlating text and the other to not include it. The allowance to skip the IBC and use the IRC for small lodging houses is only applicable where sprinklers are provided, and this change will clarify that you can't go to the IRC without including sprinklers.

Cost Impact

The code change proposal will not increase or decrease the cost of construction .

Sprinklers are already required in these occupancies. The change will help to avoid misapplication of the codes and does not add a new mandate.

Internal ID: 2384

G23-18 Part I

IBC: 311.2, 311.3

Proponent: Jason Albers, representing Eden Prairie Fire Department (jalbers@edenprairie.org)

THIS IS A 2 PART CODE CHANGE PROPOSAL. PART I WILL BE HEARD BY THE GENERAL CODE DEVELOPMENT COMMITTEE. PART II WILL BE HEARD BY THE FIRE CODE COMMITTEE. SEE THE TENTATIVE HEARING ORDERS FOR THESE COMMITTEES.

2018 International Building Code

Revise as follows:

311.2 Moderate-hazard storage, Group S-1. Storage Group S-1 occupancies are buildings occupied for storage uses that are not classified as Group S-2, including, but not limited to, storage of the following:

Aerosol products, Levels 2 and 3

Aircraft repair hangar (~~storage and repair~~)

Bags: cloth, burlap and paper

Bamboos and rattan

Baskets

Belting: canvas and leather

Books and paper in rolls or packs

Boots and shoes

Buttons, including cloth covered, pearl or bone

Cardboard and cardboard boxes

Clothing, woolen wearing apparel

Cordage

Dry boat storage (indoor)

Furniture

Furs

Glues, mucilage, pastes and size

Grains

Horns and combs, other than celluloid

Leather

Linoleum

Lumber

Motor vehicle repair garages complying with the maximum allowable quantities of hazardous materials listed in Table 307.1(1) (see Section 406.8)

Photo engravings

Resilient flooring

Self-service storage facility (mini-storage)

Silks

Soaps

Sugar

Tires, bulk storage of

Tobacco, cigars, cigarettes and snuff

Upholstery and mattresses

Wax candles

311.3 Low-hazard storage, Group S-2. Storage Group S-2 occupancies include, among others, buildings used for

the storage of noncombustible materials such as products on wood pallets or in paper cartons with or without single thickness divisions; or in paper wrappings. Such products are permitted to have a negligible amount of plastic *trim*, such as knobs, handles or film wrapping. Group S-2 storage uses shall include, but not be limited to, storage of the following:

- Aircraft hangar fixed base operator (FBO)
- Asbestos
- Beverages up to and including 16-percent alcohol in metal, glass or ceramic containers
- Cement in bags
- Chalk and crayons
- Dairy products in nonwaxed coated paper containers
- Dry cell batteries
- Electrical coils
- Electrical motors
- Empty cans
- Food products
- Foods in noncombustible containers
- Fresh fruits and vegetables in nonplastic trays or containers
- Frozen foods
- Glass
- Glass bottles, empty or filled with noncombustible liquids
- Gypsum board
- Inert pigments
- Ivory
- Meats
- Metal cabinets
- Metal desks with plastic tops and *trim*
- Metal parts
- Metals
- Mirrors
- Oil-filled and other types of distribution transformers
- Parking garages, open or enclosed
- Porcelain and pottery
- Stoves
- Talc and soapstones
- Washers and dryers

G23-18 Part II

IFC: 914.8.3; IBC: [F] 412.3.6

Proponent: Jason Albers, representing Eden Prairie Fire Department (jalbers@edenprairie.org)

2018 International Fire Code

914.8.3 Fire suppression for aircraft hangars. Aircraft hangars shall be provided with a fire suppression system designed in accordance with NFPA 409, based on the classification for the hangar given in Table 914.8.3.

~~**Exception:** Where a fixed base operator has separate repair facilities on site, Group II hangars operated by a fixed base operator used for storage of transient aircraft only shall have a fire suppression system, but the system shall be exempt from foam requirements. Group II hangars as defined in NFPA 409 storing private aircraft without major maintenance or overhaul are exempt from foam suppression requirements.~~

2018 International Building Code

Revise as follows:

[F] 412.3.6 Fire suppression. Aircraft hangars shall be provided with a fire suppression system designed in accordance with NFPA 409, based on the classification for the hangar given in Table 412.3.6.

~~**Exception:** fixed base operator has separate repair facilities on site, Group II hangars operated by a fixed base operator used for storage of transient aircraft only shall have a fire suppression system, but the system is exempt from foam requirements. Group II hangars as defined in NFPA 409 storing private aircraft without major maintenance or overhaul are exempt from foam suppression requirements.~~

Reason:

If you follow the history of how we got to where we are today from the introduction of high expansion foam in airplane hangars, you will see that the original intent was to suppress fire under aircraft with expansive wing spans that would otherwise shelter the fire from overhead sprinkler heads. In 2009 there were two changes to the International fire code that directly impacted small municipal airports and the ability to build group II hangars without foam suppression.

A group II hangar as defined by NFPA 409 states the aircraft access door shall be 28 ft. or less and a single fire area between 20,000-40,000 square feet. 914.8.3 Made fixed base operators (FBO) in group II hangars require foam systems and made it exempt for hangars with transient aircraft. Prior to 2009 the language found in these sections allowed for group II hangars with fixed based operators to be exempt from foam requirements.

The occupancy classification also changed in 2009 putting all aircraft into the S-1 category. Prior to 2009 there were two separate classifications S-1 was for aircraft repair hangars and S-2 was all other aircraft hangars. It should be noted that automobile parking garages (open and closed) has remained an S-2 and did not change in 2009. The argument for changing the fixed base operator S-2 to an S-1 is due to the fuel stored in the wings of the aircraft. For comparison the auto ignition temperature of gasoline is 475 F and Jet fuel is 410 F making the fuels of concern very similar in nature, yet enclosed parking garages are protected by wet/dry fire sprinkler systems even though the fuel capacity at many parking garages far exceeds what is stored in the wings of an airplane.

Research:

Research on this subject was difficult to obtain, with that being said I could locate very little research that would have been sufficient to support change to the wording in 2009 either. Most of the research I was able to locate was over a decade old and conducted primarily by the Navy and Air Force. According to a study called Aircraft Hangar Fire Suppression Design Study by Scheffey and Wakelin (June 16, 2000) "All DoD service branches have been plagued with false activations involving foam-water deluge sprinkler systems over aircraft with open cockpits. These false activations have been caused by numerous sources including: lightning strikes which introduced transient voltage spikes into the fire alarm system; water hammers in aging underground water distribution systems; accidental releases by maintenance personnel; deliberate acts of vandalism; accidental activation of manual pull stations; failure of pressure relief valves at pumping stations; roof water leakage into overhead heat detection systems and, false activation of fire detection systems. This prompted all branches of DoD to pursue alternative fire protection designs, which would provide the desired level of protection." Furthermore the study continues to explore the cost of installing, operating, re-charging and maintaining these expensive systems.

Both the Air Force and Navy are looking for ways to remove or improve high-expansion foam in their hangars. The two services (Air Force, Navy) with highest potential for dollar loss are looking for ways to remove foam systems, yet the fire code is forcing privately owned hangars to comply with an un-necessary suppression system.



Bibliography:

Aircraft Hangar Fire Suppression Design Study Scheffey and Wakelin 2000

High Cost of Hangar System Discharge Johnson 2014 <http://thecodecoach.blogspot.com/2014/11/high-cost-of-hangar-system-discharge.html>

Cost Impact

The code change proposal will decrease the cost of construction .

Who would be impacted?

The groups that are affected by the current requirement of foam systems and the groups that will be affected if the language is changed, is significant. First, keeping foam systems as they are currently required in the IFC has a substantial impact on fixed base operators from a financial perspective as well as the employees from a safety perspective. Financially, the installation of high-expansion foam has a substantial cost, exceeding \$250,000 in many cases for the initial design and installation. I have recently been personally involved with the plan review and installation of a foam system with wet sprinklers and the cost exceeded \$400,000. The continued annual maintenance and inspections of these systems also has a substantial financial burden. The highest financial burden comes from lost business or inability to use airplanes that were affected by a discharge. Any plane that is exposed to a discharge can take up to six months to get flying again and many of the systems need to be replaced. (Johnson 11/5/14 <http://thecodecoach.blogspot.com/2014/11/high-cost-of-hangar-system-discharge.html>) Furthermore, in at least one case an employee of an FBO has died in an accidental discharge event of high-expansion foam. From the standpoint of the local municipality who has this type of hangar in their jurisdiction, there becomes a new topic that has to be trained on. This added training will add costs to the training budgets as well as additional inspections from the AHJ. In turn this becomes an additional cost to the FBO as well as the local fire department.

Internal ID: 3490

G24-18

IBC: 311.3

Proponent: Lawrence Cousin, representing Self

2018 International Building Code

Revise as follows:

311.3 Low-hazard storage, Group S-2. Storage Group S-2 occupancies include, among others, buildings used for the storage of noncombustible materials such as products on wood pallets or in paper cartons with or without single thickness divisions; or in paper wrappings. Such products are permitted to have a negligible amount of plastic *trim*, such as knobs, handles or film wrapping. Group S-2 storage uses shall include, but not be limited to, storage of the following:

- Asbestos
- Beverages up to and including 16-percent alcohol in metal, glass or ceramic containers
- Cement in bags
- Chalk and crayons
- Dairy products in nonwaxed coated paper containers
- Dry cell batteries
- Electrical coils
- Electrical motors
- Electrical room
- Empty cans
- Food products
- Foods in noncombustible containers
- Fresh fruits and vegetables in nonplastic trays or containers
- Frozen foods
- Glass
- Glass bottles, empty or filled with noncombustible liquids
- Gypsum board
- Inert pigments
- Ivory
- Meats
- Mechanical room
- Metal cabinets
- Metal desks with plastic tops and *trim*
- Metal parts
- Metals
- Mirrors
- Oil-filled and other types of distribution transformers
- Parking garages, open or enclosed
- Porcelain and pottery
- Stoves
- Talc and soapstones
- Washers and dryers

Reason:

This will ease the use of Tables in which Mechanical/Electrical room needs to be classified as Low-hazard storage (S-2) and benefit from the relief afforded by the code. A case in point is trying to increase the egress distance from Mechanical room to outside of a school building. The distance is restricted, but became generous when the Mechanical/Electrical room is interpreted as housing storage (S-2) materials.

Cost Impact

The code change proposal will not increase or decrease the cost of construction .

By adding a mechanical room and electrical room to S-2 occupancy it does not change how the room is constructed. The code still has requirements for how the room is constructed based on size or amps of equipment.

Internal ID: 1281

G25-18

IBC: 312.1

Proponent: Todd Christopher, Salt Lake City Corporation, representing self (todd.christopher@slcgov.com)

2018 International Building Code

Revise as follows:

312.1 General. Buildings and structures of an accessory character and miscellaneous structures not classified in any specific occupancy shall be constructed, equipped and maintained to conform to the requirements of this code commensurate with the fire and life hazard incidental to their occupancy. Group U shall include, but not be limited to, the following:

- Agricultural buildings
- Aircraft hangars, accessory to a one- or two-family residence (see Section 412.4)
- Barns
- Carports
- Communication equipment structures with a *gross floor area* of less than 1,500 square feet (139 m²)
- Fences more than ~~6-7~~ feet (~~1829-2134~~ mm) in height
- Grain silos, accessory to a residential occupancy
- Livestock shelters
- Private garages
- Retaining walls
- Sheds
- Stables
- Tanks
- Towers

Reason:

IBC Section 105.2 indicates that fences not over 7 feet in height are exempt from permits. IBC Section 312.1 indicates that fences more than 6 feet in height are to be considered as a Group U occupancy, therefore subject to current code requirements. It seems these two code sections should be consistent. The code requirements for a Group U occupancy cannot be enforced upon a 6 foot tall fence where fences not more than 7 feet in height are exempt.

Cost Impact

The code change proposal will not increase or decrease the cost of construction .

No perceived impact to construction cost.

Internal ID: 2026

G26-18

IBC: [F] 402.7.2

Proponent: Ed Kullik, representing ICC Building Code Action Committee (bcac@iccsafe.org)

THIS CODE CHANGE WILL BE HEARD BY THE FIRE CODE COMMITTEE. SEE THE TENTATIVE HEARING ORDER FOR THIS COMMITTEE

2018 International Building Code

SECTION 402 COVERED MALL AND OPEN MALL BUILDINGS

Revise as follows:

[F] 402.7 Emergency systems. *Covered and open mall buildings, anchor buildings and associated parking garages shall be provided with emergency systems complying with Sections 402.7.1 through 402.7.5.*

[F] 402.7.2 Smoke control. ~~Where a covered mall building contains an atrium, Atriums connecting three or more stories in covered mall buildings shall be provided with a smoke control system shall be provided in accordance with Section 909.404.5~~

~~**Exception:** A smoke control system is not required in covered mall buildings where an atrium connects only two stories.~~

Reason:

This proposal simply makes a more direct reference to the need for a smoke control system instead of sending the reader to Section 404.5 and through the exception. The technical requirements do not change. Smoke control is only required where an atrium connects 3 or more stories whether associated with a covered mall or other type of building.

This proposal is submitted by the ICC Building Code Action Committee (BCAC). BCAC was established by the ICC Board of Directors in July 2011 to pursue opportunities to improve and enhance assigned International Codes or portions thereof. In 2017 the BCAC has held 3 open meetings. In addition, there were numerous Working Group meetings and conference calls for the current code development cycle, which included members of the committee as well as any interested party to discuss and debate the proposed changes. Related documentation and reports are posted on the BCAC website at: <https://www.iccsafe.org/codes-tech-support/codes/code-development-process/building-code-action-committee-bcac>.

Cost Impact

The code change proposal will not increase or decrease the cost of construction .

This proposal simply makes the provisions more direct as to when smoke control would be required in a covered mall building.

Internal ID: 185

G27-18

Proponent: Ed Kullik, Chair, representing ICC Building Code Action Committee (bcac@iccsafe.org)

2018 International Building Code

Delete without substitution:

~~**403.2.2 Seismic considerations.** For seismic considerations, see Chapter 16.~~

Reason:

This proposal deletes the existing pointer to Chapter 16 for seismic considerations. The existing pointer was useful when Chapter 16 substantially copied seismic design requirements from ASCE 7, including direction on which seismic design methods were applicable to high-rise buildings and limitations on lateral force-resisting systems for buildings of certain heights in certain seismic design categories. All of that information with the exception of the basic information needed for a building official to verify the seismic ground motions and seismic design category has been removed from Chapter 16 and replaced with references to ASCE 7. Thus, the pointer is no longer needed.

This proposal is submitted by the ICC Building Code Action Committee (BCAC). BCAC was established by the ICC Board of Directors in July 2011 to pursue opportunities to improve and enhance assigned International Codes or portions thereof. In 2017 the BCAC has held 3 open meetings. In addition, there were numerous Working Group meetings and conference calls for the current code development cycle, which included members of the committee as well as any interested party to discuss and debate the proposed changes. Related documentation and reports are posted on the BCAC website at: <https://www.iccsafe.org/codes-tech-support/codes/code-development-process/building-code-action-committee-bcac>.

Cost Impact

The code change proposal will not increase or decrease the cost of construction.

This is an editorial clarification and will therefore not increase or decrease the cost of construction.

Internal ID: 171

G28-18

IBC: [F] 403.3.2; IFC: 914.3.1.2

Proponent: Stephen DiGiovanni, representing ICC Ad Hoc Committee on Tall Wood Buildings (TWB) (TWB@iccsafe.org)

THIS CODE CHANGE PROPOSAL WILL BE HEARD BY THE IFC COMMITTEE. PLEASE CONSULT THE AGENDA FOR THE IFC COMMITTEE.

2018 International Building Code

Revise as follows:

[F] 403.3.2 Water supply to required fire pumps. In all buildings that are more than 420 feet (128 m) in building height, and buildings of Type IVA and IVB construction that are more than 120 feet in building height, required fire pumps shall be supplied by connections to not fewer than two water mains located in different streets. Separate supply piping shall be provided between each connection to the water main and the pumps. Each connection and the supply piping between the connection and the pumps shall be sized to supply the flow and pressure required for the pumps to operate.

Exception: Two connections to the same main shall be permitted provided that the main is valved such that an interruption can be isolated so that the water supply will continue without interruption through not fewer than one of the connections.

2018 International Fire Code

914.3.1.2 Water supply to required fire pumps. In all buildings that are more than 420 feet (128 m) in building height, and buildings of Type IVA and IVB construction that are more than 120 feet in building height, required fire pumps shall be supplied by connections to not fewer than two water mains located in different streets. Separate supply piping shall be provided between each connection to the water main and the pumps. Each connection and the supply piping between the connection and the pumps shall be sized to supply the flow and pressure required for the pumps to operate.

Exception: Two connections to the same main shall be permitted provided that the main is valved such that an interruption can be isolated so that the water supply will continue without interruption through not fewer than one of the connections.

Reason:

The Ad Hoc Committee on Tall Wood Buildings (TWB) was created by the ICC Board to explore the science of tall wood buildings and take action on developing code changes for tall wood buildings. The TWB has created several code change proposals with respect to the concept of tall buildings of mass timber and the background information is at the end of this Statement. Within the statement are important links to information, including documents and videos, used in the deliberations which resulted in these proposals.

The Ad Hoc Committee has discussed a number of proposals to potentially increase the permitted height and area for Type IV structures, specifically mass timber buildings adding additional Types IVA, IVB & IVC. One of the basic requirements incorporated into these proposed increased heights and areas is the added active and passive protection features to these structures.

The Code Technology Committee, in response to the events of September 11, 2001, submitted proposals for water supply to super high-rise buildings of 420' and higher. This requirement was adopted due to the recognized importance of insuring a continuous water supply to the active fire protection systems in the event of a fire in these structures. This recommendation was highlighted in the National Institute of Standards and Technology's (NIST) report on the structural collapses on September 11th.

This code change proposal brings this same concept to Type IV structures of 120' and higher. This added protection feature would be unique to Type IVA and IVB construction (as proposed in a related code change - see table below) due to the potential contribution of the mass timber to the fuel load in the event of a fire. Due to the limitations of fire service aerial apparatus' ability to apply water to elevated floors the Ad Hoc Committee felt 120' was an appropriate height to initiate the requirement. Another consideration is that currently the code permits structures up to 85' so the committee identified the next level within the codes for additional requirements. Considerations were also given to the difficulty of fire service companies accessing elevated floors under fire conditions.

The Ad Hoc Committee has proposed greater permitted heights and areas of mass timber construction than those contained in the 2018 IBC. The Ad Hoc believes this code change proposal is an important component to these proposed increased heights and areas. If the permitted heights and areas of mass timber construction are raised it is imperative we adopt related code change proposals to insure the reliable performance of active and passive protection features to insure the safety of occupants and responding fire fighters.

Background information: The ICC Board approved the establishment of an ad hoc committee for tall wood buildings in December of 2015. The purpose of the ad hoc committee is to explore the science of tall wood buildings and to investigate the feasibility and take action on developing code changes for tall wood buildings. The committee is comprised of a balance of stakeholders with additional opportunities for interested parties to participate in the four Work Groups established by the ad hoc committee, namely: Code; Fire; Standards/Definitions; and Structural. For more information, be sure to visit the ICC website <https://www.iccsafe.org/codes-tech-support/cs/icc-ad-hoc-committee-on-tall-wood-buildings/> (link active and up to date as of 12/27/17). As seen in the “Meeting Minutes and Documents” and “Resource Documents” sections of the committee web page, the ad hoc committee reviewed a substantial amount of information in order to provide technical justification for code proposals.

The ad hoc committee developed proposals for the followings code sections. The committee believes this package of code changes will result in regulations that adequately address the fire and life safety issues of tall mass timber buildings.

IBC Code Section	Description
403.3.2	Water supply requirements for fire pumps in high rise buildings of Type IVA and IVB construction.
504.3	Allowable building height (feet) for buildings of Type IVA, IVB and IVC construction. No changes to Type IV HT construction.
504.4	Allowable building height (stories) for buildings of Type IVA, IVB and IVC construction. No changes to Type IV HT.
506.2	Allowable building area for buildings of Type IVA, IVB and IVC construction. No changes to Type IV HT.
508.4.4.1 509.4.1.1 (new)	Requirements for mass timber building elements serving as fire barriers or horizontal assemblies in buildings of Type IVB or IVC construction.
602.4	Type of Construction requirements for new proposed types of construction: Types IVA, IVB and IVC. No changes to Type IV HT construction. Includes definitions for new terms: Mass timber and Noncombustible protection (mass timber). THIS IS THE KEY CODE CHANGE PROPOSAL WHICH OUTLINES THE CONSTRUCTION REQUIREMENTS FOR THE PROPOSED NEW TYPE OF MASS TIMBER BUILDINGS. THE PROPOSAL ALSO ADDRESSES CONCEALED SPACES, ADHESIVE PERFORMANCE AND EXTERIOR WALL PROTECTION.
703.8 (new)	The performance method to determine the increase to the fire resistance rating provided by noncombustible protection applied to the mass timber building element.
703.9 (new)	Requirements for sealants and adhesives to be placed at abutting edges and intersections of mass timber building elements. The reason statement references a Group B proposal to Chapter 17 for special inspection requirements of sealants and adhesives.
718.2.1	Requirements on the use of mass timber building elements used for Fireblocking.
722.7 (new)	Requirements for the fire resistance rating of mass timber elements, including minimum required protection and gypsum board attachment requirements.
3102	Requirements for membrane structures using Type IV HT construction.
3314.7 (new)	New special precautions during construction of buildings of Types IVA, IVB and IVC construction: Standpipes; Water supply for fire department connections; Noncombustible protection required for mass timber elements as construction height increases.
Appendix	Requirements for walls, floors and roofs of Type IV HT construction in buildings located in Fire Districts.
IFC Code Section	Description
701.6	Requirements which stipulate the owner's responsibility to maintain inventory of all required fire resistance rated construction in buildings of Types IVA and IVB construction. This includes an annual inspection and proper repair where necessary.
Proposed changes to be submitted in 2019 Group B	
IBC Chapter 17	Required special inspections of mass timber construction <ul style="list-style-type: none"> • Structural • Sealants and adhesives (see IBC 703.8)
IBC Chapter 23	An update to referenced standard APA PRG 320 Standard for Performance –rated Cross-laminated Timber which is currently undergoing revision to ensure the adequacy of the adhesives under fire conditions.

In addition, fire tests designed to simulate the three new construction types (Types IVA, IVB and IVC) in the ad hoc committee proposals were conducted at the Alcohol Tobacco and Firearms test lab facility. The TWB was involved in the design of the tests, and many members witnessed the test in person or online. The results of the series of 5 fire tests provide additional support for these proposals, and validate the fire performance for each of the types of construction proposed by the committee. The fire tests consisted of one-bedroom apartments on two levels, with both apartments having a corridor leading to a stair. The purpose of the tests was to address the contribution of mass timber to a fire, the performance of connections, the performance of through-penetration fire stops, and to evaluate conditions for responding fire personnel.

To review a summary of the fire tests, please visit:

<http://bit.ly/ATF-firetestreport>

To watch summary videos of the fire tests, which are accelerated to run in 3 ½ minutes, please visit:

<http://bit.ly/ATF-firetestvideos>

Both of these links were confirmed active on 12/27/17.

Cost Impact

The code change proposal will not increase or decrease the cost of construction .

This section provides information that was not previously set forth in the code, and does not change the requirements of current code, thus there is no cost impact when compared with present requirements.

Internal ID: 959

G29-18

IBC: 403.5.6

Proponent: Ed Kullik, Chair, representing ICC Building Code Action Committee (bcac@iccsafe.org)

THIS CODE CHANGE WILL BE HEARD BY THE MEANS OF EGRESS COMMITTEE. SEE THE TENTATIVE HEARING ORDER FOR THIS COMMITTEE.

2018 International Building Code

Delete without substitution:

~~**403.5.6 Emergency escape and rescue.** Emergency escape and rescue openings specified in Section 1030 are not required.~~

Reason:

EERO not required for high-rises in Section 1030.1, so the exception not needed in the high-rise provisions in Section 403.

This is one of a series of 11 proposals to coordinate the Emergency Escape and Rescue Openings (EERO) technical criteria in the I-codes. Please see the proposal for the definition of Emergency Escape and Rescue Openings for additional information.

This proposal is submitted by the ICC Building Code Action Committee (BCAC). BCAC was established by the ICC Board of Directors in July 2011 to pursue opportunities to improve and enhance assigned International Codes or portions thereof. In 2017 the BCAC has held 3 open meetings. In addition, there were numerous Working Group meetings and conference calls for the current code development cycle, which included members of the committee as well as any interested party to discuss and debate the proposed changes. Related documentation and reports are posted on the BCAC website at: <https://www.iccsafe.org/codes-tech-support/codes/codedevelopment-process/building-code-action-committee-bcac>.

Cost Impact

The code change proposal will not increase or decrease the cost of construction .

There is no requirement or change in technical criteria for construction.

Internal ID: 457

G30-18

IBC: 404.1

Proponent: Sarah Rice, The Preview Group, representing Myself (srice@preview-group.com)

2018 International Building Code

Revise as follows:

404.1 General. In other than Group H occupancies, ~~and where permitted by Section 712.1.7~~, the provisions of Sections 404.1 through 404.10 shall apply to buildings or structures containing vertical openings defined as "Atriums."

Exception: Vertical openings that comply with Sections 712.1.1 through 712.1.3, and Sections 712.1.9 through 712.1.14.

Reason:

Regardless of the number of changes that people make to Section 404 (Atriums) and Section 712 (Vertical Openings), and the countless words the IBC Commentary uses to help the code user, numerous people still do not fully comprehend that the provisions found in Section 404 are NOT the only way allowed to protect a 2-story large "hole" in a floor/ceiling assembly in a building that only has 2 stories, i.e., a hole intended to allow daylight to move to another story.

In the IBC the construction of a floor/ceiling assembly is regulated by Section 711 (Floor and Roof Assemblies). And though not defined, in the IBC any "hole" in a floor ceiling assembly is considered to be a "vertical opening." Sorry to give a mini-seminar but it seems like people don't know that Section 711 specifically tells the code user that regardless of whether or not a floor/ceiling assembly has a fire rating, the continuity rule says "Assemblies shall be continuous without vertical openings, except as permitted by this section and Section 712.

Section 712 (Vertical Openings) contains 16 means by which "holes" in floors can be addressed. For a large "hole" in a floor/ceiling assembly that is intended to allow daylight to move to another story, Section 712 really offers only 2 options:

712.1.7 – Atriums (Section 404)

712.1.9 – Two-story openings

Even a new code user knows that if a word or term is italicized then there is a definition of the term in Chapter 2. And in reading Section 712.1.7 they will see that the term "atrium" is italicized. So off to Chapter 2 they go where they find the following definition – "**ATRIUM.** An opening connecting two or more stories other than enclosed stairways, elevators, hoistways, escalators, plumbing, electrical, air-conditioning or other equipment, which is closed at the top and not defined as a mall. Stories, as used in this definition, do not include balconies within assembly groups or mezzanines that comply with Section 505."

The "hole" outlined above meets the definition of "atrium" so hey, they are done – they know that it must be protected as outlined in Section 404. They NEVER got to the 2nd option in 712.1.9.

Several cycles ago, the 1st sentence in Section 404.1 was added to tell the code user that they only should have gotten to Section 404 through the use of Section 712.1.1, but based upon the number of questions I receive as a code consultant to architects, engineers, designers, owners, developers and even code official each year on this topic – this pointer has not worked.

Through the elimination of the pointer to Section 712.1.7 and the addition of the exception, this code change is intended to make it clear that not all 2-story vertical openings must comply with Section 404, but that the design option found in 712.1.9 IS ALWAYS another option.

Cost Impact

The code change proposal will increase the cost of construction .

If accepted the cost of construction may be decreased as not all of the provisions for an atrium will have to be included.

Internal ID: 2165

G31-18

IBC: 404.1, 404.9, 404.9.1, 404.9.2, 404.9.3, 404.10, 712.1.7, TABLE 1017.2, 1017.3.2 (New), 1017.3.2.1 (New), 1017.3.2.2 (New), 1017.3.2.3 (New), 1028.1, (IFC[BE] TABLE 1017.2, 1017.3.2 (New), 1017.3.2.1 (New), 1017.3.2.2 (New), 1017.3.2.3 (New), 1028.1)

Proponent: Ed Kullik, Chair, representing ICC Building Code Action Committee (bcac@iccsafe.org)

THIS CODE CHANGE WILL BE HEARD BY THE MEANS OF EGRESS COMMITTEE. SEE THE TENTATIVE HEARING ORDER FOR THIS COMMITTEE.

2018 International Building Code

Revise as follows:

404.1 General. ~~In other than Group H occupancies, and where permitted by Section 712.1.7, the~~ The provisions of Sections 404.1 through 404.10 shall apply to buildings containing atriums. Atriums are not permitted in buildings or structures containing vertical openings defined as "Atriums."classified as Group H.

404.9 Exit access travel distance. *Exit access* travel distance for areas open to an *atrium* shall comply with the requirements of ~~this section.~~Section 1017.

Delete without substitution:

~~**404.9.1 Egress not through the atrium.** Where required access to the exits is not through the *atrium*, *exit access* travel distance shall comply with Section 1017.~~

~~**404.9.2 Exit access travel distance at the level of exit discharge.** Where the path of egress travel is through an *atrium* space, *exit access* travel distance at the *level of exit discharge* shall be determined in accordance with Section 1017.~~

~~**404.9.3 Exit access travel distance at other than the level of exit discharge.** Where the path of egress travel is not at the *level of exit discharge* from the *atrium*, that portion of the total permitted *exit access* travel distance that occurs within the *atrium* shall be not greater than 200 feet (60 960 mm).~~

Revise as follows:

404.10 Interior exit stairways. ~~Not greater than 50 percent~~ Discharge of *interior exit stairways* are permitted to egress through an atrium ~~on the *level of exit discharge* shall be~~ in accordance with Section 1028.

712.1.7 Atriums. ~~In other than Group H occupancies, atriums complying with Section 404 shall be permitted.~~ Atriums in buildings shall comply with Section 404.

**TABLE 1017.2
EXIT ACCESS TRAVEL DISTANCE^a**

OCCUPANCY	WITHOUT SPRINKLER SYSTEM (feet)	WITH SPRINKLER SYSTEM (feet)
A, E, F-1, M, R, S-1	200 ^e	250 ^b
I-1	Not Permitted	250 ^b
B	200	300 ^c
F-2, S-2, U	300	400 ^c
H-1	Not Permitted	75 ^d
H-2	Not Permitted	100 ^d
H-3	Not Permitted	150 ^d
H-4	Not Permitted	175 ^d
H-5	Not Permitted	200 ^c
I-2, I-3	Not Permitted	200 ^c
I-4	150	200 ^c

For SI: 1 foot = 304.8 mm.

- a. See the following sections for modifications to *exit access* travel distance requirements:

Section 402.8: For the distance limitation in malls.

~~Section 404.9: For the distance limitation through an atrium space.~~

Section 407.4: For the distance limitation in Group I-2.

Sections 408.6.1 and 408.8.1: For the distance limitations in Group I-3.

Section 411.3: For the distance limitation in special amusement buildings.

Section 412.6: For the distance limitations in aircraft manufacturing facilities.

Section 1006.2.2.2: For the distance limitation in refrigeration machinery rooms.

Section 1006.2.2.3: For the distance limitation in refrigerated rooms and spaces.

Section 1006.3.3: For buildings with one exit.

Section 1017.2.2: For increased distance limitation in Groups F-1 and S-1.

Section 1029.7: For increased limitation in assembly seating.

Section 3103.4: For temporary structures.

Section 3104.9: For pedestrian walkways.

- b. Buildings equipped throughout with an *automatic sprinkler system* in accordance with Section 903.3.1.1 or 903.3.1.2. See Section 903 for occupancies where *automatic sprinkler systems* are permitted in accordance with Section 903.3.1.2.
- c. Buildings equipped throughout with an *automatic sprinkler system* in accordance with Section 903.3.1.1.
- d. Group H occupancies equipped throughout with an *automatic sprinkler system* in accordance with Section 903.2.5.1.
- e. Group R-3 and R-4 buildings equipped throughout with an *automatic sprinkler system* in accordance with Section 903.3.1.3. See Section 903.2.8 for occupancies where automatic sprinkler systems are permitted in accordance with Section 903.3.1.3.

1017.3 Measurement. *Exit access* travel distance shall be measured from the most remote point of each room, area or space along the natural and unobstructed path of horizontal and vertical egress travel to the entrance to an exit.

Exception: In open parking garages, *exit access* travel distance is permitted to be measured to the closest riser of an *exit access stairway* or the closest slope of an *exit access ramp*.

1017.3.1 Exit access stairways and ramps. Travel distance on *exit access stairways* or *ramps* shall be included in the *exit access* travel distance measurement. The measurement along *stairways* shall be made on a plane parallel and tangent to the *stair tread nosings* in the center of the *stair* and landings. The measurement along *ramps* shall be made on the walking surface in the center of the *ramp* and landings.

Add new text as follows:

1017.3.2 Atriums. Exit access travel distance for areas open to an atrium shall comply with the requirements of this section.

1017.3.2.1 Egress not through the atrium. Where required access to the exits is not through the atrium, exit access travel distance shall comply with Section 1017.2.

1017.3.2.2 Exit access travel distance at the level of exit discharge. Where the path of egress travel is through an atrium space, exit access travel distance at the level of exit discharge shall be determined in accordance with Section 1017.2.

1017.3.2.3 Exit access travel distance at other than the level exit discharge. Where the path of egress travel is not at the level of exit discharge from the atrium, that portion of the total permitted exit access travel distance that occurs within the atrium shall be not greater than 200 feet (60 960 mm).

Revise as follows:

1028.1 General. Exits shall discharge directly to the exterior of the building. The *exit discharge* shall be at grade or shall provide a direct path of egress travel to grade. The *exit discharge* shall not reenter a building. The combined use of Exceptions 1 and 2 shall not exceed 50 percent of the number and minimum width or required capacity of the required exits.

Exceptions:

1. Not more than 50 percent of the number and minimum width or required capacity of *interior exit stairways* and *ramps* is permitted to egress through areas, including atriums, on the level of discharge provided that all of the following conditions are met:
 - 1.1. Discharge of *interior exit stairways* and *ramps* shall be provided with a free and unobstructed path of travel to an exterior *exit* door and such *exit* is readily visible and identifiable from the point of termination of the enclosure.
 - 1.2. The entire area of the *level of exit discharge* is separated from areas below by construction conforming to the *fire-resistance rating* for the enclosure.
 - 1.3. The egress path from the *interior exit stairway* and *ramp* on the *level of exit discharge* is protected throughout by an *approved automatic sprinkler system*. Portions of the *level of exit discharge* with access to the egress path shall be either equipped throughout with an *automatic sprinkler system* installed in accordance with Section 903.3.1.1 or 903.3.1.2, or separated from the egress path in accordance with the requirements for the enclosure of *interior exit stairways* or *ramps*.
 - 1.4. Where a required *interior exit stairway* or *ramp* and an *exit access stairway* or *ramp* serve the same floor level and terminate at the same *level of exit discharge*, the termination of the *exit access stairway* or *ramp* and the *exit discharge* door of the *interior exit stairway* or *ramp* shall be separated by a distance of not less than 30 feet (9144 mm) or not less than one-fourth the length of the maximum overall diagonal dimension of the building, whichever is less. The distance shall be measured in a straight line between the *exit discharge* door from the *interior exit stairway* or *ramp* and the last tread of the *exit access stairway* or termination of slope of the *exit access ramp*.
2. Not more than 50 percent of the number and minimum width or required capacity of the *interior exit stairways* and *ramps* is permitted to egress through a vestibule provided that all of the following conditions are met:
 - 2.1. The entire area of the vestibule is separated from areas below by construction conforming to the *fire-resistance rating* of the *interior exit stairway* or *ramp enclosure*.
 - 2.2. The depth from the exterior of the building is not greater than 10 feet (3048 mm) and the length is not greater than 30 feet (9144 mm).
 - 2.3. The area is separated from the remainder of the *level of exit discharge* by a *fire partition* constructed in accordance with Section 708.

Exception: The maximum transmitted temperature rise is not required.

 - 2.4. The area is used only for *means of egress* and exits directly to the outside.
3. *Horizontal exits* complying with Section 1026 shall not be required to discharge directly to the exterior of the building.

Reason:

The purpose of this proposal is to relocate portions of the Section 404 atrium requirements to other appropriate portions of the IBC. As defined in Chapter 2, an atrium is a particular type of a vertical opening in a building or structure, but not the only method permitted by Chapter 7 for dealing with a vertical opening. A proposal last cycle (G51-15) attempted to relocate the entire Section 404 provisions into Section 712. While the proposal was disapproved by a vote of 8-6, there was support expressed for considering a relocation of these provisions if clarifications to the existing text were provided and at least a minimum set of provisions be retained in Chapter 4 as a starting point for addressing requirements specific to certain building features. This proposal retains Section 404 but makes some targeted relocations. In all cases, pointers are left in Section 404 so the link is not totally lost and code users still have Section 404 as a guide to all of the considerations for atriums. Requirements relative to exit access travel distance and interior exit stair discharge are also moved to Section 1017 and Section 1028 respectively. While these provisions perhaps appear specific to atriums, they are not entirely self-contained and clearly need to be evaluated as part of the general travel distance and exit discharge requirements for the building. For exit access travel distance, the

atrium-specific provisions are added under the exiting Section 1017.3 on measurement of exit access travel distance. For exit discharge, a reference to atriums is added under Exception #1 of Section 1028.1. Finally, the charging language is clarified. A circular reference between Section 404 and Section 712.1 is removed. The existing language, especially in Section 404, also makes it vague as to whether an atrium is allowed in a Group H building or structure, versus another method of treating a vertical opening. The implication (especially in Section 712.1) is that such an atrium is not permitted. The charging language in both sections is revised accordingly. In addition, an exception is added permitting a vertical opening meeting the definition of an atrium to be constructed in accordance with any of the other methods for treating a vertical opening (e.g. a shaft enclosure per Section 712.1.1 or a generic two-story opening per Section 712.1.9).

This proposal is submitted by the ICC Building Code Action Committee (BCAC). BCAC was established by the ICC Board of Directors in July 2011 to pursue opportunities to improve and enhance assigned International Codes or portions thereof. In 2017 the BCAC has held 3 open meetings. In addition, there were numerous Working Group meetings and conference calls for the current code development cycle, which included members of the committee as well as any interested party to discuss and debate the proposed changes. Related documentation and reports are posted on the BCAC website at: <https://www.iccsafe.org/codes-tech-support/codes/code-development-process/building-code-action-committee-bcac>.

Cost Impact

The code change proposal will not increase or decrease the cost of construction .

The code change proposal will not increase or decrease the cost of construction. This is an editorial reorganization to place requirements in a more appropriate location.

Internal ID: 174

G32-18

IBC: 404.5

Proponent: Sarah Rice, representing Myself (srice@preview-group.com)

2018 International Building Code

Revise as follows:

404.5 Smoke control. A smoke control system shall be installed in accordance with Section 909.

Exception-Exceptions:

1. In other than Group I-2, and Group I-1, Condition 2, smoke control is not required for *atriums* that connect only two stories.
2. A smoke control system is not required for atriums connecting more than two stories when all of the following are met:
 - 2.1. Only the 2 lowest stories shall be permitted to be open to the atrium.
 - 2.2. All stories above the lowest 2 stories shall be separated from the atrium in accordance with Section 404.6.

Reason:

As stated in Section 909, the purpose of a smoke control systems is to provide a tenable environment for the evacuation or relocation of occupants. A smoke control system is NOT intended for the preservation of contents, the timely restoration of operations or for assistance in fire suppression or overhaul activities. Smoke control systems that are required and regulated by the IBC serve a different purpose than the smoke- and heat-venting provisions found in Section 910 and they are not considered exhaust systems under Chapter 5 of the International Mechanical Code.

In an atrium that connects more than 2 stories, the smoke control systems is intended to maintained the height of the lowest horizontal surface of the smoke layer interface to at least 6 feet above any walking surface that forms a portion of a required egress system within the smoke zone for a period of not less than either 20 minutes or 1.5 times the calculated egress time, whichever is less.

But what if the only walking surfaces in the atrium are on the 2 lowest stories of the atrium? What if all the walls above the 2 lowest stories are solid without operable openings? What purpose does the smoke control system then serve? We contend none. And if the smoke control system has no real value, then why install it? See Figures 1 - 3 for examples of these spaces.

This proposed change seeks to exempt atriums that connect more than 2 stories from having to have a smoke control system when 1) there are no walking surfaces in the atrium above the 2 lowest stories and 2) there are no operable windows or doors above the 2 lowest stories in the atrium and 3) the walls of the atrium on the upper levels are constructed per Section 404.6 - atrium enclosures..





Cost Impact

The code change proposal will decrease the cost of construction .

The cost savings of not providing smoke control system in a building with an atrium will decrease the cost of construction.

Internal ID: 2381

G33-18

IBC: 404.6

Proponent: Raymond Grill, representing Self (ray.grill@arup.com)

2018 International Building Code

Revise as follows:

404.6 Enclosure of atriums. *Atrium* spaces shall be separated from adjacent spaces by a 1-hour *fire barrier* constructed in accordance with Section 707 or a *horizontal assembly* constructed in accordance with Section 711, or both.

Exceptions:

1. A *fire barrier* is not required where a glass wall forming a smoke partition is provided. The glass wall shall comply with all of the following:
 - 1.1. Automatic sprinklers are provided along both sides of the separation wall and doors, or on the room side only if there is not a walkway on the *atrium* side. The sprinklers shall be located between 4 inches and 12 inches (102 mm and 305 mm) away from the glass and at intervals along the glass not greater than 6 feet (1829 mm). The sprinkler system shall be designed so that the entire surface of the glass is wet upon activation of the sprinkler system without obstruction;
 - 1.2. The glass wall shall be installed in a gasketed frame in a manner that the framing system deflects without breaking (loading) the glass before the sprinkler system operates; and
 - 1.3. Where glass doors are provided in the glass wall, they shall be either *self-closing* or automatic-closing.
2. A *fire barrier* is not required where a glass-block wall assembly complying with Section 2110 and having a $\frac{3}{4}$ -hour *fire protection rating* is provided.
3. A *fire barrier* is not required between the *atrium* and the adjoining spaces of up to three floors of the *atrium* provided that such spaces are accounted for in the design of the smoke control system.
4. A fire barrier is not required between the atrium and the adjoining spaces where the atrium is not required to be provided with a smoke control system.
5. A horizontal assembly is not required between the atrium and openings for escalators complying with Section 712.1.3.
6. A horizontal assembly is not required between the atrium and openings for exit access stairways and ramps complying with 1019.3.4.

Reason:

Floor openings for escalators and exit access stairways and ramps meeting the sections identified in the proposal are protected. The protection consists of draft curtains around the floor opening and additional sprinklers. The size of the floor opening is also limited. The provision of the draft curtain and sprinklers limit the potential of smoke spread through the opening and that communicate via these types of openings should not be considered to be part of the atrium.

Cost Impact

The code change proposal will decrease the cost of construction .

If levels that are connected via protected escalator or access stairway or ramp openings are considered part of the atrium, there are potentially significant costs associated with providing smoke control for those levels.

Internal ID: 2277

G34-18

IBC: 202, (New), 404.6, 716.4 (New), 716.4.1 (New), 716.4.2 (New), 716.4.3 (New), Chapter 35

Proponent: Tessa Quinones, The Hickman Group, representing Smoke Guard (admin@thehickmangroup.com)

THIS CODE CHANGE WILL BE HEARD BY THE IBC FIRE SAFETY COMMITTEE. SEE THE TENTATIVE HEARING ORDER FOR THIS COMMITTEE

2018 International Building Code

SECTION 202 DEFINITIONS

FIRE PROTECTIVE CURTAIN ASSEMBLY. An assembly consisting of a fabric curtain, bottom bar, guides, coil, operating, and closing system.

404.6 Enclosure of atriums. *Atrium* spaces shall be separated from adjacent spaces by a 1-hour *fire barrier* constructed in accordance with Section 707 or a *horizontal assembly* constructed in accordance with Section 711, or both.

Exceptions:

1. A *fire barrier* is not required where a glass wall forming a smoke partition or a 20-minute fire protective curtain assembly is provided. The glass wall or fire protective curtain assembly shall comply with all of the following:
 - 1.1. Automatic sprinklers are provided along both sides of the separation wall, fire protective curtain assembly and doors, or on the room side only if there is not a walkway on the *atrium* side. The sprinklers shall be located between 4 inches and 12 inches (102 mm and 305 mm) away from the glass and at intervals along the glass or fire protective curtain assembly not greater than 6 feet (1829 mm). The sprinkler system shall be designed so that the entire surface of the glass or fire protective curtain assembly is wet upon activation of the sprinkler system without obstruction;
 - 1.2. The glass wall shall be installed in a gasketed frame in a manner that the framing system deflects without breaking (loading) the glass before the sprinkler system operates; and
 - 1.3. The fire protective curtain assembly shall be installed in accordance with Section 716.4 and shall be actuated in conjunction with the atrium smoke control system, and
 - ~~1.3.1.4.~~ Where glass doors are provided in the glass wall, they shall be either *self-closing* or automatic-closing.
2. A *fire barrier* is not required where a glass-block wall assembly complying with Section 2110 and having a $\frac{3}{4}$ -hour *fire protection rating* is provided.
3. A *fire barrier* is not required between the *atrium* and the adjoining spaces of up to three floors of the *atrium* provided that such spaces are accounted for in the design of the smoke control system.
4. A fire barrier is not required between the atrium and the adjoining spaces where the atrium is not required to be provided with a smoke control system.

Add new text as follows:

716.4 Fire protective curtain assembly. Approved fire protective curtain assemblies shall be constructed of any materials or assembly of component materials tested without hose stream in accordance with UL 10D, and shall comply with the Sections 716.4.1 through 716.4.3

716.4.1 Label. Fire protective curtain assemblies used as opening protectives in fire rated walls and smoke partitions shall be labeled in accordance with Section 716.2.9.

716.4.2 Smoke and draft control. Fire protective curtain assemblies used to protect openings where smoke and draft control assemblies are required shall comply with Section 716.2.1.4.

716.4.3 Installation. Fire protective curtain assemblies shall be installed in accordance with NFPA 80.

Add new standard(s) follows:

10D-14:

Standard for Fire Tests of Fire Protective Curtain Assemblies

Reason:

During the last cycle, FS 102-15 was disapproved at least in part on the proposed use of fabric fire protective curtain assemblies as an opening protective having a one-hour fire protection rating and to replace one hour fire barriers. This proposal allows the use of a 20-minute fire protective curtain assembly as an alternative to a non-rated glass wall when protected with sprinklers for the enclosure of an atrium. In addition, the proposal allows fire protective curtain assemblies as an opening protective as permitted by other sections of the IBC.

Both of these applications are consistent with the scope of UL 10D which reads:

These requirements cover the evaluation of fire protective curtain assemblies intended to provide supplemental passive fire protection as part of an engineered fire protection system. Fire protective curtain assemblies provide nonstructural separation only, and are not intended to be substituted for structural hourly rated partitions or opening protectives that have been tested for fire endurance and hose stream performance.

The proposed definition and uses are consistent with NFPA 80-2016 and UL 10D. Some products can also pass UL 1784 for an "S" label.

The proposed requirement that the assembly be "approved" in addition to "listed" allows the Code Official to specifically approve the proposed application.

Cost Impact

The code change proposal will not increase or decrease the cost of construction .

The use of the fire protective curtain assembly is an option and as such, atria enclosures can continue to be constructed as currently permitted.

Analysis: A review of the standard proposed for inclusion in the code, UL 10D-14, with regard to the ICC criteria for referenced standards (Section 3.6 of CP#28) will be posted on the ICC website on or before April 2, 2018.

Internal ID: 2015

G35-18

IBC: 404.10.1 (New)

Proponent: David Collins, representing The American Institute of Architects (dcollins@preview-group.com)

THIS CODE CHANGE WILL BE HEARD BY THE MEANS OF EGRESS COMMITTEE. SEE THE TENTATIVE HEARING ORDER FOR THIS COMMITTEE.

2018 International Building Code

Add new text as follows:

404.10.1 Exit stairs in an atrium. Where an atrium contains an interior exit stairway all the following shall be met:

1. The exit stair shall have access from a minimum of two directions.
2. The distance between an exit stair in an atrium, and a minimum of one exit stair enclosed in accordance with Section 1023.2 shall comply with Section 1007.1.1.
3. Exit access travel distance within the atrium shall be measured to the nosing of the landing at the top of the stair on each level served.
4. At least one exit shall not be located in the same atrium.

Reason:

An exit stair is currently permitted to be in an atrium enclosure by IBC Sections 2023.1 and 1023.2, which allows enclosure per Section 404.6. These new provisions for the conditions for use of an atrium for an exit stair adds four specific criteria for their use as an exit.

Provision 1 - Accessed from two directions

This means that the exit stair in the atrium must have two paths of travel to allow the occupants to pass by the stair.

Provision 2 - Separation distance

To make it clear that the exit stair in the atrium must be separated from at least one other exit stair meeting IBC Section 1023.2 by the minimum separation distance prescribed in Section 1007.1.1.

Provision 3 - Travel distance

The travel distance within the atrium to the exit stair in the atrium is to be measured to the nosing at the level the stair is serving.

Provision 4 - At least one exit is not in the atrium.

Requires that at least one exit is not permitted to be in the same atrium. The current provisions of Section 404.10 prohibit more than 50% of exit stairs from egressing through the atrium at the level of exit discharge.

Cost Impact

The code change proposal will decrease the cost of construction .

This change will facilitate design decisions, reduce the number of required exit enclosures in buildings with an atrium and help with review and approval, reducing the cost of construction.

Internal ID: 1694

G36-18

IBC: 406.2.4

Proponent: Stephen Skalko, representing Stephen V. Skalko, P.E. & Associates, LLC (svskalko@svskalko-pe.com); Stephen Szoke, representing American Concrete Institute (steve.szoke@concrete.org); William Hall, Portland Cement Association, representing Alliance For Concrete Codes and Standards (jhall@cement.org); Jason Krohn, representing Precast/Prestressed Concrete Institute (jkrohn@pci.org)

2018 International Building Code

406.2.4 Floor surfaces. Floor surfaces shall be of concrete or similar approved noncombustible and nonabsorbent materials. The area of floor used for the parking of automobiles or other vehicles shall be sloped to facilitate the movement of liquids to a drain or toward the main vehicle entry doorway. The surface of vehicle fueling pads in motor fuel-dispensing facilities shall be in accordance with Section 406.7.1.

Exceptions:

1. Asphalt parking surfaces shall be permitted at ground level for public parking garages and private carports.
- ~~2. Floors of Group S-2 parking garages shall not be required to have a sloped surface.~~
- 3.2. Slip-resistant, nonabsorbent, interior floor finishes having a critical radiant flux not more than 0.45 W/cm², as determined by ASTM E648 or NFPA 253, shall be permitted in repair garages.

Reason:

The charging language in Section 406.1 specifies that all motor-vehicle-related occupancies, which includes open parking garages in accordance with 406.5 and enclosed parking garages in accordance with 406.6. Further, Section 406.2.4 requires floors in motor-vehicle-related occupancies to be of concrete or similar noncombustible and nonabsorbent materials, and be provided with a slope. However, Exception No. 2 to Section 406.2.4 creates confusion for the user because it exempts Group S-2 parking garages from the sloped floor provision. Per Section 311.3 open and enclosed parking garages are an S-2 occupancy group. By exempting Group S-2 parking garages from the sloped floor provisions Exception No. 2 renders the second sentence in the subsection meaningless. In addition, exempting parking garages from the sloped floor provisions is detrimental to the structure.

Exception No. 2 was introduced into the code with code change G78-06/07. The reason given was “Many larger parking structures are constructed with prefabricated materials that are difficult if not impossible to design to slope all surfaces”. This reason statement made no reference to studies or other technical information to indicate providing sloped floors in large parking structures of prefabricated materials is problematic. In fact, in the precast concrete industry, which represents the largest segment of the prefabricated materials industry used for parking garages, sloped floors are an essential part of the design of these types of structures to insure proper durability.

In Section 3.2 of Precast Prestressed Concrete Parking Structures: Recommended Practice for Design & Construction [1] poor drainage is listed as one of the major factors detrimental to a durable parking structure. Frequently vehicles can transport deleterious materials such as oils and deicing salts into the parking structures from the streets. Sloped floors provide a means to allow these materials to be removed from the deck surface by the vertical drainage systems. This reduces the likelihood that these deleterious materials will cause damage to the concrete wearing surface and the reinforcement within. Section 3.4.2 of the Recommended Practice is devoted to providing design guidance and construction techniques with sloped floors to achieve proper drainage in support of this durable design goal.

Section 6.2 of ACI 362.1R, Guide for the Design and Construction of Durable Concrete Parking Structures [2] also recommends that sloped floors be provided for parking structures to improve durability. This Guide suggests this is especially important since ponding water can result in increased deposits of chlorides in the concrete, which can be detrimental to the long term structural integrity of the structure.

Exception No. 2 should be deleted from Section 406.2.4 to eliminate the confusion in this section and preserve the durability of parking structures.

Bibliography:

[1] Precast Prestressed Concrete Parking Structures: Recommended Practice for Design & Construction, 3rd edition, 2015, Precast Prestressed Concrete Institute, Publication MNL-129-15, www.pci.org last visited December 2015

[2] ACI 362.1R-12 Guide for the Design and Construction of Durable Concrete Parking Structures, 2012 American Concrete Institute, Farmington Hills, MI 48331

Cost Impact

The code change proposal will not increase or decrease the cost of construction .

Deletion of the exception will not have an adverse impact on cost because common design and construction practice for parking garages already includes sloped floors in the design for durability.

Internal ID: 1540

G37-18

IBC: TABLE 406.5.4

Proponent: Stephen Skalko, Stephen V. Skalko, P.E. & Associates, LLC, representing Stephen V. Skalko, P.E. & Associates, LLC (svskalko@svskalko-pe.com); Jason Krohn, representing Precast/Prestressed Concrete Institute (jkrohn@pci.org); William Hall, Portland Cement Association, representing Alliance For Concrete Codes and Standards (jhall@cement.org)

2018 International Building Code

Revise as follows:

**TABLE 406.5.4
OPEN PARKING GARAGES AREA AND HEIGHT**

TYPE OF CONSTRUCTION	AREA PER TIER (square feet)	HEIGHT (in tiers)		
		Ramp access	Mechanical access	
			Automatic sprinkler system	
			No	Yes
IA	Unlimited	Unlimited	Unlimited	Unlimited
IB	Unlimited	12 tiers	12 tiers	18 tiers
IIA	50,000 <u>75,000</u>	10 tiers	10 tiers	15 tiers
IIB	50,000	8 tiers	8 tiers	12 tiers
IV	50,000	4 tiers	4 tiers	4 tiers

For SI: 1 square foot = 0.0929 m².

Reason:

When the International Building Code (IBC) the drafting committees were developing the IBC, they commonly used the least stringent fire safety provisions from one of the legacy codes (i.e. BOCA National Building Code, Standard Building Code, Uniform Building Code) in establishing the requirements. However, for open parking garages the least stringent values in the Standard Building Code (SBC) were not used. The SBC permitted open parking structures of non-combustible construction with less fire resistance (i.e. SBC Type IV construction, IBC Type II construction) to be built up to 400,000 sqft in area per tier. This area value, which was placed in the SBC in the early 1980's, was based on the use of noncombustible materials for construction of the open parking structure, the open sided features for the parking structure which reduced the risk of adverse impact from vehicle fires and the documented low fire risk vehicles pose to the stability of open parking structures[1],[2].

Additional studies of fire experience in open parking structures in the United States since those earlier ones still supports the conclusion that vehicle fires pose a low risk of fire damage to the parking structure. The more recent analysis of parking garage structure fires (i.e. NFPA[3], Parking Market Research Company [4]) by the Fire Safety Committee of the Parking Consultants Council concluded that in about 98.7% of the fires no structural damage occurred due to the parking structure fires studied[5]. This suggests that the present values in Table 406.5.4 for Open Parking Garages of IBC Type II construction are more stringent than necessary based on the low risk of fire damage to the structural elements from vehicle fires and should be permitted to increase.

During the 2015 Group A cycle for code changes to the 2012 IBC, a similar code change was submitted by PCI for consideration (G101-15). The IBC General Code Committee recommended disapproval of the proposal at the code development hearing, suggesting there was merit to allow bigger open parking garages when constructed using buildings of fire resistive construction, however the table values proposed in G101-15 were considered too large. Based on that feedback PCI has modified the original proposal to reduce the area per tier permitted for Type IIA construction as reflected in this code change.

The area per tier proposed is based on a common open parking garage design utilizing a footprint of 240-feet X 315-feet (4 bays @ 60-ft/bay X 35 parking spaces @ 9-ft each), which totals 75,600 sf. The table value was rounded to 75,000 sf. This area per tier, based on 10 tiers, results in an aggregate parking area consistent with the aggregate allowable floor area for an enclosed sprinklered S-2 parking garage, per Tables 504.4 and 506.2.

Based on the low risk of vehicle fires and resulting damage, and the open sided features of these garages, this proposal will permit open parking garages of Type IIA construction to be built to areas like those permitted for sprinklered enclosed parking garages.

Bibliography:

[1] Harris, Dr. Leslie, Market Research Associates, Survey of Fire Experience in Automobile Parking Structures in the United States and Canada, January 31, 1972.

[2] Harris, Dr. Leslie, Market Research Associates, 1979 Update of the Survey of Fire Experience in Automobile Parking Structures in the United States and Canada, January 31, 1979.

[3] Ahrens, Marty, National Fire Protection Association, Structure and Vehicle Fires in General Vehicle Parking Garages, January 2006

[4] Dendra, Dale F., Parking Market Research Company, McLean, VA, Parking Garage Fires (A Statistical Analysis of Parking Garage Fires in the United States 1986-1988), April 1992

[5] Parking Consultants Council Fire Safety Committee, Parking Structure Fire Facts, December 2008

Cost Impact

The code change proposal will decrease the cost of construction .

Permitting larger open parking garages of Type IIA construction will result in a reduction in cost without any compromise in fire safety through savings in material and construction methods required for open parking structures that would otherwise have to meet Type IB construction.

Internal ID: 1544

G38-18

IBC: 406.5.7, 1006.3.3 (IFC[BE] 1006.3.3)

Proponent: Robert J Davidson, Davidson Code Concepts, LLC, representing Self (rjd@davidsoncodeconcepts.com)

THIS CODE CHANGE WILL BE HEARD BY THE MEANS OF EGRESS COMMITTEE. SEE THE TENTATIVE HEARING ORDER FOR THIS COMMITTEE.

2018 International Building Code

Revise as follows:

406.5.7 Means of egress. ~~Where persons other than parking attendants are permitted, open~~ Open parking garages shall meet the *means of egress* requirements of Chapter 10. ~~Where persons other than parking attendants are not permitted, there shall be not fewer than two exit stairways. Each exit stairway shall be not less than 36 inches (914 mm) in width.~~ Lifts shall be permitted to be installed for use of employees only, provided that they are completely enclosed by noncombustible materials.

1006.3.3 Single exits. A single *exit* or access to a single *exit* shall be permitted from any *story* or occupied roof where one of the following conditions exists:

1. The *occupant load*, number of *dwelling units* and common path of egress travel distance do not exceed the values in Table 1006.3.3(1) or 1006.3.3(2).
2. Rooms, areas and spaces complying with Section 1006.2.1 with *exits* that discharge directly to the exterior at the *level of exit discharge*, are permitted to have one *exit* or access to a single *exit*.
- ~~3. Parking garages where vehicles are mechanically parked shall be permitted to have one exit or access to a single exit.~~
- ~~3.4.~~ Group R-3 and R-4 occupancies shall be permitted to have one *exit* or access to a single *exit*.
- ~~4.5.~~ Individual single-story or multistory *dwelling units* shall be permitted to have a single *exit* or access to a single *exit* from the *dwelling unit* provided that both of the following criteria are met:
 - ~~4.1.5.1.~~ The *dwelling unit* complies with Section 1006.2.1 as a space with one *means of egress*.
 - ~~4.2.5.2.~~ Either the *exit* from the *dwelling unit* discharges directly to the exterior at the *level of exit discharge*, or the *exit access* outside the *dwelling unit's* entrance door provides access to not less than two *approved independent exits*.

Reason:

The purpose of this change is to address limitations in requirements for means of egress components for parking garages. Section 406.5.7 where the requirements are different for attendants than for the general public in open parking garages. And Section 1006.3.3 which allows for a single exit or exit access for parking garages with mechanical parking.

Section 406.5.7 assumes there is a lower life hazard for attendant parking than when individuals park their own vehicles. Not only are the number of exits potentially reduced depending upon the size of the parking structure, the width is allowed to be 36 inches rather than the required 44 inches.

There is no justification to assume attendant valet parking presents a lower egress need than public parking. Just as public parking can have ebbs and flows so can valet parking. Every parking garage has times when there is peak usage, in the case of valet parking the number of attendants is increased based upon when the highest in and out flows are expected. Hotels for example might have a morning rush to leave and then an afternoon rush for arrivals.

The ebbs and flows are also different for where the parking garage is, a factor the code ignores. Some facilities may have attendant parking when they open, but down the line eliminate it for self parking. A factor not considered.

The main factor not considered is where the fire may be. Open parking garages do not have automatic fire suppression, the fires generate considerable heat, smoke, toxics, all of which can move anywhere on the fire floor based upon atmospheric conditions potentially blocking the path to the limited egress paths.

The reduction in the stairway widths also ignores the fact that the fire service will use the same stairways to gain access to the fire floor hauling equipment with them.

A good example of how the reduction in protection is convoluted is that in many cases the portion for valet parking is

open to the portion for public access separated only by barriers easily overcome by occupants if they actually have physical barriers. A fire on the level shared can impact both areas and/or can force the public to climb over a potential low barrier to escape through the valet area.

Section 406.5.7 is proposed to be modified to simply point to Chapter 10 for egress requirements and leave the allowance for employee lifts.

Section 1006.3.3 Exception 3 allows parking garages utilizing mechanical parking to have a single exit. There are no qualifications on size of the space or suppression requirements. There is no technical justification for allowing a single exit condition where the exit could be blocked by a fire event. The Commentary includes:

"Item 3 allows for one exit from all stories in a parking garage where the cars are mechanically parked. This is in recognition of the extremely low occupant load in this unique type of building. The single exit would be for maintenance and service personnel who could be on the different levels...."

So because employees are not part of the public their lives are worth less? What about the single fire event taking out the single stairway at a lower level? From a practical or a fire protection standpoint this has no justification.

This exception also ignores the fact that the stairways do double duty, egress and the fire service use the stairways to access the fire floor.

Since there is no justification for the single exit allowance from a life safety perspective or from a firefighting access viewpoint Exception 3 for Section 1006.3.3 is recommended for deletion.

An additional important factor to consider is that the materials in vehicles has changed to add more combustible synthetic material, thinner/lighter metals and a growing increase of alternative fueled vehicles, GH2, CNG, LPG and Lithium-Ion batteries. Electric Vehicle charging stations have been installed within parking garages to encourage their use.

Basically, the current requirements for parking garages, open or closed, in the codes are based on old vehicle concepts and studies.

Multi-vehicle large fires can occur and have occurred. As in any multi-story building, effective firefighting actions to protect life and property involved being able to quickly apply water to the fire. The type of fire and danger presented by that fire has increased as the use of alternative fueled vehicles has increased. Access is important to suppressing the fire with hose lines.

It's time the requirements for parking garages were improved recognizing the increased fire hazards and fuel loads presented by alternative fueled vehicles and vehicles with more plastic components.

Background material.

<http://www.urbanfiretraining.com/parking-garages>.

<http://www.firerescuemagazine.com/articles/print/volume-7/issue-2/strategy-and-tactics/fighting-vehicle-fires-in-parking-garages.html>

<http://www.fireengineering.com/ap-news/2018/01/01/parking-garage-fire-destroys-hundreds-of-cars-in-uk.html>

<https://www.youtube.com/watch?v=KVx6avRTNCA>

<https://www.youtube.com/watch?v=HK0U-PKJ1NE>

Cost Impact

The code change proposal will increase the cost of construction .

This code change will increase the cost of construction for open parking garages and parking garages with mechanical parking by requiring additional enclosed exit stairs.. But the increased is over weighed by the negative safety impact potential to occupants of the increase of fuel loads in today's parking garages.

Internal ID: 2304

G39-18

IBC: 202(New), 406.6.4(New), 406.6.4.1(New), 406.6.4.2(New), 406.6.4.3(New), 406.6.4.4(New), 406.6.4.5(New), TABLE 508.4; 903.2.10.2(New), TABLE 902.3.11.6 (IFC 202(New), 903.2.10.2(New), TABLE 902.3.11.6)

Proponent: James Carver, El Segundo Fire Department, representing El Segundo Fire Department (JCarver@elsegundo.org)

2018 International Building Code

SECTION 202 DEFINITIONS

Add new definition as follows:

202 MECHANICAL-ACCESS ENCLOSED PARKING GARAGE An enclosed parking garage other than single car stacking systems which employs parking machines, lifts, elevators or other mechanical devices for vehicle moving from and to street level and in which public occupancy in the garage is prohibited in all areas except the vehicle access bay.

Add new text as follows:

406.6.4 Mechanical-access garages. Mechanical-access enclosed parking garages shall be in accordance with Sections 406.6.4.1 through 406.6.4.5.

406.6.4.1 Separation. Mechanical-access enclosed parking garages shall be separated from other occupancies and accessory uses by not less than 2-hour fire barriers constructed in accordance with Section 707 or by not less than 2-hour horizontal assemblies constructed in accordance with Section 711, or both.

406.6.4.2 Smoke removal. A mechanical smoke removal system, in accordance with Section 910.4, shall be provided for all areas containing an enclosed mechanical-access parking garage.

406.6.4.3 Fire control equipment. The fire control equipment, consisting of the fire alarm control unit, mechanical ventilation controls and emergency shut down shall be provided in a room with exterior access. The room size and location shall be approved by the fire code official.

406.6.4.4 Firefighter access. Access doors shall be provided at the ground level for firefighter access as approved by the fire code official.

406.6.4.5 Emergency shutdown switch. A manually activated emergency shutdown switch shall be provided for use by emergency personnel.

Revise as follows:

**TABLE 508.4
REQUIRED SEPARATION OF OCCUPANCIES (HOURS)^f**

OCCUPANCY	A, E		I-1 ^a , I-3, I-4		I-2		R ^a		F-2, S-2 ^b , U		B ^e , F-1, M, S-1		H-1		H-2		H-3, H-4		H-5	
	S	NS	S	NS	S	NS	S	NS	S	NS	S	NS	S	NS	S	NS	S	NS	S	NS
A, E	N	N	1	2	2	NP	1	2	N	1	1	2	NP	NP	3	4	2	3	2	NP
I-1 ^a , I-3, I-4	-	-	N	N	2	NP	1	NP	1	2	1	2	NP	NP	3	NP	2	NP	2	NP
I-2	-	-	-	-	N	N	2	NP	2	NP	2	NP	NP	NP	3	NP	2	NP	2	NP
R ^a	-	-	-	-	-	-	N	N	1 ^c	2 ^c	1	2	NP	NP	3	NP	2	NP	2	NP
F-2, S-2 ^b , U	-	-	-	-	-	-	-	-	N	N	1	2	NP	NP	3	4	2	3	2	NP
B ^e , F-1, M, S-1	-	-	-	-	-	-	-	-	-	-	N	N	NP	NP	2	3	1	2	1	NP
H-1	-	-	-	-	-	-	-	-	-	-	-	-	N	NP	NP	NP	NP	NP	NP	NP
H-2	-	-	-	-	-	-	-	-	-	-	-	-	-	-	N	NP	1	NP	1	NP
H-3, H-4	-	-	-	-	-	-	-	-	-	-	-	-	-	-	-	-	1 ^d	NP	1	NP
H-5	-	-	-	-	-	-	-	-	-	-	-	-	-	-	-	-	-	-	N	NP

S = Buildings equipped throughout with an automatic sprinkler system installed in accordance with Section 903.3.1.1.

NS = Buildings not equipped throughout with an automatic sprinkler system installed in accordance with Section 903.3.1.1.

N = No separation requirement.

NP = Not Permitted.

- a. See Section 420.
- b. The required separation from areas used only for private or pleasure vehicles shall be reduced by 1 hour but not to less than 1 hour.
- c. See Section ~~406.3.2~~ 406.3.2 and 406.6.4.
- d. Separation is not required between occupancies of the same classification.
- e. See Section 422.2 for ambulatory care facilities.
- f. Occupancy separations that serve to define fire area limits established in Chapter 9 for requiring fire protection systems shall also comply with Section 707.3.10 and Table 707.3.10 in accordance with Section 901.7.

2018 International Fire Code

SECTION 202 GENERAL DEFINITIONS

Add new definition as follows:

202 MECHANICAL-ACCESS ENCLOSED PARKING GARAGE An enclosed parking garage, other than single car stacking system, which employs parking machines, lifts, elevators or other mechanical devices for vehicle moving from and to street level and in which public occupancy in the garage is prohibited in all areas except the vehicle access bay.

Add new text as follows:

903.2.10.2 Mechanical-access enclosed parking garages. An approved automatic sprinkler system shall be provided throughout buildings used for the storage of motor vehicles in a mechanical-access enclosed parking garage. The portion of the building that contains the mechanical-access enclosed parking garage shall be protected with a performance-based design specially engineered sprinkler system.

Revise as follows:

**TABLE 903.2.11.6
ADDITIONAL REQUIRED FIRE SUPPRESSION SYSTEMS**

SECTION	SUBJECT
<u>903.2.10.2</u>	<u>Mechanical-access enclosed parking garages</u>
914.2.1	Covered and open mall buildings
914.3.1	High-rise buildings
914.4.1	Atriums
914.5.1	Underground structures
914.6.1	Stages
914.7.1	Special amusement buildings
914.8.2	Airport traffic control towers
914.8.3, 914.8.6	Aircraft hangars
914.9	Flammable finishes
914.10	Drying rooms
914.11.1	Ambulatory care facilities
1029.6.2.3	Smoke-protected assembly seating
1103.5.1	Existing Group A occupancies
1103.5.2	Pyroxylin plastic storage in existing buildings
1103.5.3	Existing Group I-2 occupancies
1103.5.4	Existing Group I-2, Condition 2 occupancies
1103.5.4	Pyroxylin plastics
2108.2	Dry cleaning plants
2108.3	Dry cleaning machines
2309.3.2.6.2	Hydrogen motor fuel-dispensing area canopies
2404.2	Spray finishing in Group A, E, I or R
2404.4	Spray booths and spray rooms
2405.2	Dip-tank rooms in Group A, I or R
2405.4.1	Dip tanks
2405.9.4	Hardening and tempering tanks
2703.10	HPM facilities
2703.10.1.1	HPM work station exhaust
2703.10.2	HPM gas cabinets and exhausted enclosures
2703.10.3	HPM exit access corridor
2703.10.4	HPM exhaust ducts
2703.10.4.1	HPM noncombustible ducts
2703.10.4.2	HPM combustible ducts
2807.3	Lumber production conveyor enclosures
2808.7	Recycling facility conveyor enclosures
3006.1	Class A and B ovens
3006.2	Class C and D ovens
Table 3206.2	Storage fire protection
3206.4	Storage
3704.5	Storage of more than 1,000 cubic feet of loose combustible fibers
5003.8.4.1	Gas rooms
5003.8.5.3	Exhausted enclosures
5004.5	Indoor storage of hazardous materials
5005.1.8	Indoor dispensing of hazardous materials
5104.4.1	Aerosol product warehouses
5106.3.2	Aerosol display and merchandising areas

5306.2.1	Exterior medical gas storage room
5306.2.2	Interior medical gas storage room
5306.2.3	Medical gas storage cabinet
5606.5.2.1	Storage of smokeless propellant
5606.5.2.3	Storage of small arms primers
5704.3.7.5.1	Flammable and combustible liquid storage rooms
5704.3.8.4	Flammable and combustible liquid storage warehouses
5705.3.7.3	Flammable and combustible liquid Group H-2 or H-3 areas
6004.1.2	Gas cabinets for highly toxic and toxic gas
6004.1.3	Exhausted enclosures for highly toxic and toxic gas
6004.2.2.6	Gas rooms for highly toxic and toxic gas
6004.3.3	Outdoor storage for highly toxic and toxic gas
6504.1.1	Pyroxylin plastic storage cabinets
6504.1.3	Pyroxylin plastic storage vaults
6504.2	Pyroxylin plastic storage and manufacturing

For SI: 1 cubic foot = 0.023 m³.

Reason:

Enclosed mechanical-access parking garages are being constructed in the United States on an increasing basis, yet there is no prescriptive code requirements for these occupancies. These occupancies are unique from the traditional open mechanical-access parking garage in that there are no openings, the entire structure is enclosed. These occupancies are more similar to automated high rack storage systems, they have no floors, no stairwells and no above ground level access, except maintenance walkways and ladders. With these being a silent occupancy type, the Code does not provide the code official with prescriptive requirements. There are fires involving parked vehicles with the vehicle parked and the ignition system off. If a fire were to occur in an enclosed mechanical-access parking garage, unless the local code authority required additional fire protection during construction, they do not have a point-setter to code requirements. Where these systems have been installed, there is not a consistent fire protection methodology to protecting these structures from a fire.

An enclosed mechanical-access parking garage offers many firefighting challenges; most are constructed in a building shell, without a floor system. The vehicles are parked in a cage/rack system, with no safe elevated access to the interior of the structure. With firefighter safety in mind and to have the ability to use fixed fire suppression to extinguish and/or control these fires, the code proposal is presented.

IFC Section 202 adds a definition for these occupancies. Open mechanical-access parking garages are defined in the Code, but do not pose the firefighting challenge as an enclosed mechanical access parking garage. An open parking garage has floors, stairwells, standpipe connections and natural ventilation. An enclosed garage is in a box, no stairwells or floors or standpipes for elevated firefighting, and no ventilation to remove the products of combustion, heat and super-heated gases.

IBC Section 406 6.1.3 is added to require a minimum 2-hour fire separation between these occupancies and other uses. If a fire were to occur in the occupancy, partitioning is needed to protect adjoining occupancies and other uses until the fire can be contained by the sprinkler system and mechanical ventilation.

IFC Section 320 is added to provide basic prescriptive requirements to provide for firefighter safety and to assist in the extinguishment of these fires, providing ground level access doors for firefighting operations, a room to consolidate the required fire control equipment, mechanical smoke removal and an emergency shut down switch. These occupancies are similar to high-piled automated storage systems. The general requirements are similar to high piled rack and automated storage requirements in Chapter 32.

IFC Section 903.2.10.2 is added to prescriptively require a performance-based designed sprinkler system. With the projected fire load in these occupancies and the inability to get water to the seat of the fire, a prescriptively designed sprinkler system is not anticipated to provide the required water for fire suppression.

Footnote c in IBC Table 508.4 is added to include the new section, 406.6.1.3.

Section 320 is being added to IFC Table 903.2.11.6 to the list of occupancies requiring additional fire suppression systems.

Cost Impact

The code change proposal will decrease the cost of construction .

This proposal is to provide prescriptive language for enclosed mechanical-access parking garages. These code requirements are being currently enforced as part of a performance-based design when approved and constructed. As the designed and builder will have prescriptive requirements, they will not be required to obtain an Alternative Materials and Methods approval for each project.

Internal ID: 1452

G40-18

IBC: 407.2.6, 407.2.7 (New); IFC: 904.13 (IBC[F] 904.13)

Proponent: John Williams, representing Healthcare Committee (AHC@iccsafe.org)

2018 International Building Code

407.2.5 Nursing home housing units. In Group I-2, Condition 1 occupancies, in areas where nursing home residents are housed, shared living spaces, group meeting or multipurpose therapeutic spaces shall be permitted to be open to the *corridor*, where all of the following criteria are met:

1. The walls and ceilings of the space are constructed as required for *corridors*.
2. The spaces are not occupied as resident sleeping rooms, treatment rooms, incidental uses in accordance with Section 509, or hazardous uses.
3. The open space is protected by an automatic fire detection system installed in accordance with Section 907.
4. The *corridors* onto which the spaces open, in the same *smoke compartment*, are protected by an automatic fire detection system installed in accordance with Section 907, or the *smoke compartment* in which the spaces are located is equipped throughout with quick-response sprinklers in accordance with Section 903.3.2.
5. The space is arranged so as not to obstruct access to the required *exits*.

Revise as follows:

407.2.6 Nursing home cooking facilities. In Group I-2, Condition 1 occupancies, rooms or spaces that contain a cooking facility with domestic cooking appliances shall be permitted to be open to the corridor where all of the following criteria are met:

1. The number of care recipients housed in the smoke compartment shall not be greater than 30.
2. The number of care recipients served by the cooking facility shall not be greater than 30.
3. Not more than one cooking facility area shall be permitted in a smoke compartment.
- ~~4. The types of domestic cooking appliances permitted shall be limited to ovens, cooktops, ranges, warmers and microwaves.~~
- ~~5.4.~~ The corridor shall be a clearly identified space delineated by construction or floor pattern, material or color.
- ~~6.5.~~ The space containing the domestic cooking facility shall be arranged so as not to obstruct access to the required exit.
- ~~7.6.~~ Domestic cooking hoods installed and constructed in accordance with Section 505 of the International Mechanical Codes shall be provided over cooktops and ranges. The cooking appliance shall comply with Section 407.2.7.
- ~~8. Cooktops and ranges shall be protected in accordance with Section 904.13.~~
- ~~9. A shut-off for the fuel and electrical power supply to the cooking equipment shall be provided in a location that is accessible only to staff.~~
- ~~10. A timer shall be provided that automatically deactivates the cooking appliances within a period of not more than 120 minutes.~~
- ~~11. A portable fire extinguisher shall be provided. Installation shall be in accordance with Section 906, and the extinguisher shall be located within a 30 foot (9144 mm) distance of travel from each domestic cooking appliance.~~

Add new text as follows:

407.2.7 Domestic cooking appliances. In Group I-2 occupancies, installation of cooking appliances used in domestic cooking facilities shall comply with all of the following:

1. The types of cooking appliances permitted shall be limited to ovens, cooktops, ranges, warmers and microwaves.
2. Domestic cooking hoods installed and constructed in accordance with Section 505 of the

International Mechanical Code shall be provided over cooktops and ranges.

3. Cooktops and ranges shall be protected in accordance with Section 904.13.
4. A shut-off for the fuel and electrical power supply to the cooking equipment shall be provided in a location that is accessible only to staff.
5. A timer shall be provided that automatically deactivates the cooking appliances within a period of not more than 120 minutes.
6. A portable fire extinguisher shall be provided. Installation shall be in accordance with Section 906, and the extinguisher shall be located within a 30-foot (9144 mm) distance of travel from each domestic cooking appliance.

2018 International Fire Code

Revise as follows:

904.13 Domestic cooking systems, facilities. Cooktops and ranges installed in the following occupancies shall be protected in accordance with Section 904.13.1:

1. In Group I-1 occupancies where domestic cooking facilities are installed in accordance with Section 420.8 of the International Building Code.
2. In Group I-2, ~~Condition 1~~ occupancies where domestic cooking facilities are installed in accordance with Section ~~407.2.6~~ 407.2.7 of the International Building Code.
3. In Group R-2 college dormitories where domestic cooking facilities are installed in accordance with Section 420.10 of the International Building Code.

Reason:

The intent of this proposal is for no technical change, but is to separate the requirements for domestic cooking appliances and exhaust from the allowance for that area to be open to the corridor in a nursing home. If someone wants to do a domestic cooking area in a room in a nursing home or hospital, such as for therapy or nutrition training purposes, they would still have to follow all the domestic cooking regulations for the equipment. This is also coordinated with the language for Group I-1 requirements in Section 420. This is not intended to change any of the provisions for the commercial cooking areas. The change in IFC is correlation only.

This proposal is submitted by the ICC Committee on Healthcare (CHC). The CHC was established by the ICC Board to evaluate and assess contemporary code issues relating to healthcare facilities. This is a joint effort between ICC and the American Society for Healthcare Engineering (ASHE), a subsidiary of the American Hospital Association, to eliminate duplication and conflicts in healthcare regulation. In 2017 the CHC held 2 open meetings and numerous conference calls, which included members of the committees as well as any interested parties, to discuss and debate the proposed changes. Information on the CHC, including: meeting agendas; minutes; reports; resource documents; presentations; and all other materials developed in conjunction with the CHC effort can be downloaded from the CHC website at: <https://www.iccsafe.org/codes-tech-support/cs/icc-committee-on-healthcare/>.

Cost Impact

The code change proposal will not increase or decrease the cost of construction .

This is an editorial separation with no technical changes for cooking facilities open to the corridor. This is a clarification of a domestic cooking appliance if it is within a room in a Group I-2 - currently some code officials would ask for commercial hoods, others would ask for domestic hoods.

Internal ID: 1291

G41-18

IBC: 407.2.6

Proponent: John Williams, representing Healthcare Committee (AHC@iccsafe.org)

2018 International Building Code

Revise as follows:

407.2.6 Nursing home cooking facilities. In Group I-2, Condition 1 occupancies, rooms or spaces that contain a cooking facility with domestic cooking appliances shall be permitted to be open to the corridor where all of the following criteria are met:

1. The number of care recipients housed in the smoke compartment shall not be greater than 30.
2. The number of care recipients served by the cooking facility shall not be greater than 30.
3. Not more than one cooking facility area shall be permitted in a smoke compartment.
4. The types of domestic cooking appliances permitted shall be limited to ovens, cooktops, ranges, warmers and microwaves.
5. The corridor shall be a clearly identified space delineated by construction or floor pattern, material or color.
6. The space containing the domestic cooking facility shall be arranged so as not to obstruct access to the required exit.
7. Domestic cooking hoods installed and constructed in accordance with Section 505 of the International Mechanical Code shall be provided over cooktops and ranges.
8. Cooktops and ranges shall be protected in accordance with Section 904.13.
9. A shut-off for the fuel and electrical power supply to the cooking equipment shall be provided in a location that is accessible only to staff.
10. A timer shall be provided that automatically deactivates the cooking appliances within a period of not more than 120 minutes.
11. A portable fire extinguisher shall be provided. Installation shall be in accordance with Section 906, and the extinguisher shall be located within a 30-foot (9144 mm) distance of travel from each domestic cooking appliance.

Exceptions:

1. Cooktops and ranges located within smoke compartments with no patient sleeping or patient care areas are not required to comply with this section.
2. Cooktops and ranges used for care recipient training or nutritional counseling are not required to comply with Item 8 of this section.

Reason:

If the proposal to split this section is also accepted, the exceptions would be applicable to the new section dealing with the cooktops and ranges.

This section was originally added to the code to allow nursing homes to have a more home like atmosphere, including small dining rooms and kitchen areas available to serve and possibly used by residents. The intent of this proposal is to allow for some exceptions for other domestic cooking.

Exception 1: The idea of this proposal for kitchens that outside of patient sleeping areas, such as a break room in the business area of a hospital, to not have to provide the protection features required to kitchens shared by care recipients. Hospitals are required to be sprinklered and separated. In these limited situations additional protection, shut offs, timers and additional portable fire extinguishers are not justified.

Exception 2: Exception 2 - The idea of this proposal for kitchens in therapy areas or for nutrition counseling is to not have to provide the UL300A hood protection features required to kitchens shared by care recipients.

This proposal is submitted by the ICC Committee on Healthcare (CHC). The CHC was established by the ICC Board to evaluate and assess contemporary code issues relating to healthcare facilities. This is a joint effort between ICC and the American Society for Healthcare Engineering (ASHE), a subsidiary of the American Hospital Association, to eliminate duplication and conflicts in healthcare regulation. In 2017 the CHC held 2 open meetings and numerous conference

calls, which included members of the committees as well as any interested parties, to discuss and debate the proposed changes. Information on the CHC, including: meeting agendas; minutes; reports; resource documents; presentations; and all other materials developed in conjunction with the CHC effort can be downloaded from the CHC website at: <https://www.iccsafe.org/codes-tech-support/cs/icc-committee-on-healthcare/>.

Cost Impact

The code change proposal will not increase or decrease the cost of construction .

Cooktops and ranges used for domestic purposes would still have to comply with the IMC for ventilation. This is a clarification for where additional protection, shut offs, timers and additional portable fire extinguishers are not needed.

Internal ID: 1295

G42-18

IBC: 407.3.1.1 (New), 710.5.2.1

Proponent: John Williams, Chair, representing Healthcare Committee (AHC@iccsafe.org)

2018 International Building Code

407.3 Corridor wall construction. Corridor walls shall be constructed as smoke partitions in accordance with Section 710.

407.3.1 Corridor doors. Corridor doors, other than those in a wall required to be rated by Section 509.4 or for the enclosure of a vertical opening or an exit, shall not have a required *fire protection rating* and shall not be required to be equipped with *self-closing* or automatic-closing devices, but shall provide an effective barrier to limit the transfer of smoke and shall be equipped with positive latching. Roller latches are not permitted. Other doors shall conform to Section 716.

Add new text as follows:

407.3.1.1 Door construction. Doors in corridors not required to have a fire protection rating shall comply with the following:

1. Solid doors shall have close fitting operational tolerances, head and jamb stops.
2. Dutch style doors shall have an astragal, rabbet or bevel at the meeting edges of the upper and lower door sections. Both the upper and lower door sections shall have latching hardware. Dutch style door shall have hardware that connects the upper and lower sections to function as a single leaf.
3. To provide make-up air for exhaust systems in accordance with Section 1020.5, Exception1, doors are permitted to have louvers or to have a clearance between the bottom of the door and the floor surface that is 2/3 inches (19.1 mm) maximum.

710.5 Openings. Openings in smoke partitions shall comply with Sections 710.5.1 and 710.5.2.

710.5.1 Windows. Windows in smoke partitions shall be sealed to resist the free passage of smoke or be automatic-closing upon detection of smoke.

710.5.2 Doors. Doors in smoke partitions shall comply with Sections 710.5.2.1 through 710.5.2.3.

Revise as follows:

710.5.2.1 Louvers. Doors in smoke partitions shall not include louvers.

Exception: Where permitted in accordance with Section 407.3.1.1.

Reason:

There are various type of doors used in corridors of care facilities. The additional language provides clarity and guidance on how these various types of doors are configured. These minimum configuration requirements are basics that have existed in other sections of the code, particularly at section 709.5, Exception 1. Therefore, they have existed in care facilities for some time, and are being specifically quantified in Chapter 4 to align with the CMS federal standard (K362).

This proposal is submitted by the ICC Committee on Healthcare (CHC). The CHC was established by the ICC Board to evaluate and assess contemporary code issues relating to healthcare facilities. This is a joint effort between ICC and the American Society for Healthcare Engineering (ASHE), a subsidiary of the American Hospital Association, to eliminate duplication and conflicts in healthcare regulation. In 2017 the CHC held 2 open meetings and numerous conference calls, which included members of the committees as well as any interested parties, to discuss and debate the proposed changes. Information on the CHC, including: meeting agendas; minutes; reports; resource documents; presentations; and all other materials developed in conjunction with the CHC effort can be downloaded from the CHC website at: <https://www.iccsafe.org/codes-tech-support/cs/icc-committee-on-healthcare/>.

Cost Impact

The code change proposal will not increase or decrease the cost of construction .

This adds requirement to explain what is required for a door to limit the transfer of smoke. However, it does not add cost to the healthcare industry because we already follow these requirements in the context of the CMS federal standard.

Internal ID: 602

G43-18

IBC: 407.4.4.1, 407.4.4.3

Proponent: John Williams, Chair, representing Healthcare Committee (AHC@iccsafe.org)

THIS CODE CHANGE WILL BE HEARD BY THE MEANS OF EGRESS COMMITTEE. SEE THE TENTATIVE HEARING ORDER FOR THIS COMMITTEE.

2018 International Building Code

Revise as follows:

407.4.4 Group I-2 care suites. *Care suites* in Group I-2 shall comply with Sections 407.4.4.1 through 407.4.4.4 and either Section 407.4.4.5 or 407.4.4.6.

407.4.4.1 Exit access through care suites. *Exit* access from all other portions of a building not classified as a *care suite* shall not pass through a *care suite*. ~~In a *care suite* required to have more than one exit, one exit access is permitted to pass through an adjacent *care suite* provided that all of the other requirements of Sections 407.4 and 1016.2 are satisfied.~~

407.4.4.2 Separation. *Care suites* shall be separated from other portions of the building, including other care suites, by a smoke partition complying with Section 710.

407.4.4.3 Access to corridor. Every suite shall have a door leading directly to an exit access corridor or horizontal exit. Movement from habitable rooms within the suite shall not require passage through more than three doors and 100 feet (30 480 mm) distance of travel within the travel within the suite to a door leading to the exit access corridor or horizontal exit. Where a caresuite is required to have more than one exit access door by Section 407.4.4.5.2 or 407.4.4.6.2, the additional door shall lead directly to an exit access corridor, horizontal exit or an adjacent suite.

Exception-Exceptions:

1. The distance of travel shall be permitted to be increased to 125 feet (38 100 mm) where an automatic smoke detection system is provided throughout the *care suite* and installed in accordance with NFPA 72.
2. Where two or more exit access doors are required by Section 407.4.4.5.2 or 407.4.4.6.2, not more than one of the doors shall be permitted to be exit door to an exit stairway, exit ramp, exit passageway, or an exterior exit door.

Reason:

Since this section was heavily edited in the 2012 version of the code, the federal rules have changed. This change reflects those changes and provides additional clarity relating to the exit access options out of a suite. The federal regulations stopped counting number of intervening rooms, instead relying on overall travel (K256 and K257).

This proposal is submitted by the ICC Committee on Healthcare (CHC). The CHC was established by the ICC Board to evaluate and assess contemporary code issues relating to healthcare facilities. This is a joint effort between ICC and the American Society for Healthcare Engineering (ASHE), a subsidiary of the American Hospital Association, to eliminate duplication and conflicts in healthcare regulation. In 2017 the CHC held 2 open meetings and numerous conference calls, which included members of the committees as well as any interested parties, to discuss and debate the proposed changes. Information on the CHC, including: meeting agendas; minutes; reports; resource documents; presentations; and all other materials developed in conjunction with the CHC effort can be downloaded from the CHC website at: <https://www.iccsafe.org/codes-tech-support/cs/icc-committee-on-healthcare/>.

Cost Impact

The code change proposal will not increase or decrease the cost of construction .

This proposal allows for one door out of a suite to be an exit door. This allows for additional design flexibility without adding any additional requirements.

Internal ID: 599

G44-18

IBC: 407.4.4.3

Proponent: John Williams, Chair, representing Healthcare Committee (AHC@iccsafe.org)

THIS CODE CHANGE WILL BE HEARD BY THE MEANS OF EGRESS COMMITTEE. SEE THE TENTATIVE HEARING ORDER FOR THIS COMMITTEE.

2018 International Building Code

Revise as follows:

407.4.4.3 Access to corridor. Movement from habitable rooms shall not require passage through more than three doors and 100 feet (30 480 mm) distance of travel within the suite.

~~**Exception:** The distance of travel shall be permitted to be increased to 125 feet (38 100 mm) where an automatic smoke detection system is provided throughout the care suite and installed in accordance with NFPA 72.~~

Reason:

Since this section was heavily edited in the 2012 version of the code, the federal rules have changed. Current federal requirements do not allow increase to 125ft travel distance (K225).

This proposal is submitted by the ICC Committee on Healthcare (CHC). The CHC was established by the ICC Board to evaluate and assess contemporary code issues relating to healthcare facilities. This is a joint effort between ICC and the American Society for Healthcare Engineering (ASHE), a subsidiary of the American Hospital Association, to eliminate duplication and conflicts in healthcare regulation. In 2017 the CHC held 2 open meetings and numerous conference calls, which included members of the committees as well as any interested parties, to discuss and debate the proposed changes. Information on the CHC, including: meeting agendas; minutes; reports; resource documents; presentations; and all other materials developed in conjunction with the CHC effort can be downloaded from the CHC website at: <https://www.iccsafe.org/codes-tech-support/cs/icc-committee-on-healthcare/>.

Cost Impact

The code change proposal will increase the cost of construction .

Limitations on travel distance will limit flexibility and potentially increase construction cost.

Internal ID: 598

G45-18

IBC: 202 (New), 407.4.5 (New), 407.4.5.1 (New), 407.4.5.2 (New), 407.4.5.3 (New), 407.4.1

Proponent: John Mengedoht, representing NBBJ (jmengedoht@nbbj.com)

THIS CODE CHANGE WILL BE HEARD BY THE MEANS OF EGRESS COMMITTEE. SEE THE TENTATIVE HEARING ORDER FOR THIS COMMITTEE.

2018 International Building Code

SECTION 202 DEFINITIONS

Add new definition as follows:

NON-PATIENT-CARE SUITE. In Group I-2 occupancies, a group of rooms or spaces not intended for patient sleeping, patient care or treatment, where the suite is in compliance with the requirements of Section 407.4.5.

Add new text as follows:

407.4.5 Group I-2 non-patient-care suites. Non-patient-care suites in Group I-2 shall comply with Sections 407.4.5.1 through 407.4.5.3.

407.4.5.1 Exit access through non-patient-care suites. Exit access from all other portions of a building not classified as a non-patient-care suite shall not pass through a non-patient-care suite. In a non-patient-care suite required to have more than one exit, one exit access is permitted to pass through an adjacent care suite or non-patient-care suite provided that all of the other requirements of Section 407.4 and 1016.2 are satisfied.

407.4.5.2 Separation. Non-patient-care suites shall be separated from other portions of the building by a smoke partition complying with Section 710.

407.4.5.3 Area. Non-patient-care suites shall have an area not greater than 22,500 square feet (2092 m²).

Revise as follows:

407.4.1 Direct access to a corridor. Habitable rooms in Group I-2 occupancies shall have an *exit access* door leading directly to a *corridor*.

Exceptions:

1. Rooms with *exit* doors opening directly to the outside at ground level.
2. Rooms arranged as *care suites* complying with Section 407.4.4.
3. Rooms arranged as non-patient-care suites complying with Section 407.4.5.

Reason:

The 2012 IBC added the requirement in Section 407.4.1 for Group I-2 occupancies to provide direct access (no intervening spaces) to a corridor from "habitable" rooms. Exceptions are provided for rooms with direct exits to the exterior and for rooms arranged as "care suites." Both the direct corridor access requirement and the concept of care suites are very similar to the requirements for hospitals in the 2012 NFPA 101, which hospitals also must comply with in order to receive Medicare or Medicaid funds.

The term "habitable rooms" is not defined in Section 202 but the Code Commentary indicates that it includes not only patient sleeping rooms but also patient treatment rooms as well as staff areas such as staff lounges and staff work areas. The exception to direct corridor access for care suites allows necessary flexibility in the arrangement of patient rooms and other patient care areas. However, by definition, a care suite excludes staff lounges or staff work areas that are not directly related to supervision of care recipients within a suite. This frequently results in inefficient layouts for staff areas. In addition, since the term "habitable rooms" is interpreted very broadly by code officials, the configuration of small waiting areas is also often impacted.

The NFPA 101 provides flexibility through the use of "non-patient-care" suites which, for whatever reason, were not included in the 2012 IBC or subsequent editions. This proposal is intended to bring the IBC into closer alignment with the NFPA 101 in this regard and to provide for more efficient layouts of staff areas with no negative impact on patient safety.

Since most hospitals are of Type I construction, it would theoretically be possible to classify staff areas and other areas as Group B rather than Group I-2 as a way to allow intervening spaces and more efficient layouts. By using the nonseparated occupancies provisions of IBC 508.3, no separations would be required between such areas and adjacent hospital spaces. However, the NFPA 101, which also applies to hospitals, requires a 2 hour separation between other occupancies per Section 18.1.3.2. Thus, hospital designers are often faced with the choice between inefficient layouts and the needless expense of a 2 hour fire barrier.

Cost Impact

The code change proposal will decrease the cost of construction .

By incorporating non-patient-care suites into the design of hospitals, construction cost will be decreased through more efficient layouts with less space dedicated to corridors. Alternatively, construction cost will be reduced by eliminating the need to classify staff areas as Group B with a 2 hour occupancy separation.

Internal ID: 2149

G46-18

IBC: 407.6.1 (New)

Proponent: John Williams, Chair, representing Healthcare Committee (AHC@iccsafe.org)

2018 International Building Code

407.6 Automatic-closing doors. Automatic-closing doors with hold-open devices shall comply with Sections 709.5 and 716.2.

Add new text as follows:

407.6.1 Activation of automatic-closing doors. Automatic-closing doors on hold-open devices in accordance with Section 716.2.6.6 shall also close upon activation of a fire alarm system, an automatic sprinkler system, or both. The automatic release of the hold open device on one door shall release all such doors within the same smoke compartment.

Reason:

This addition of this language is required in order to conform with Federal Standards and Centers for Medicaid and Medicare Services enforcement rules (K233). Doors that are required to be automatic-closing and on hold-open devices, were not clearly defined that they need to close upon all of these events, nor was it clear that all doors would need to close upon actuation of one door. This provides a higher level of life-safety for the residents and care recipients.

This proposal is submitted by the ICC Committee on Healthcare (CHC). The CHC was established by the ICC Board to evaluate and assess contemporary code issues relating to healthcare facilities. This is a joint effort between ICC and the American Society for Healthcare Engineering (ASHE), a subsidiary of the American Hospital Association, to eliminate duplication and conflicts in healthcare regulation. In 2017 the CHC held 2 open meetings and numerous conference calls

Cost Impact

The code change proposal will increase the cost of construction .

This may increase construction cost to interlock these doors with the fire alarm and sprinkler activation. This was already required to connect to the smoke detection system per Section 716.2.6.6. However, it does not add cost to the healthcare industry because certified facilities already follow these requirements in the context of the federal standards.

Internal ID: 590

G47-18

IBC: 408.9

Proponent: Raymond Grill, Arup, representing Self (ray.grill@arup.com)

2018 International Building Code

Revise as follows:

408.9 Windowless buildings. For the purposes of this section, a windowless building or portion of a building is one with nonopenable windows, windows not readily breakable or without windows. Windowless buildings shall be provided with an engineered smoke control system to provide a tenable environment for exiting from the *smoke compartment* in ~~the area of fire origin in~~ accordance with Section 909 for each windowless *smoke compartment*.

Reason:

Providing a tenable environment within the area of fire origin can be impractical to impossible depending on the fire. Take an example of a fire within a cell. If an inmate were to utilize an accelerant to ignite combustibles within the cell, it would be immediately untenable. Detention centers are required to have at least two smoke compartments on stories providing inmate housing. The number of occupants in a smoke compartment and the travel distances within the compartment are limited to facilitate evacuation. Detention centers typically provide smoke control utilizing the pressure differential method to contain smoke to the compartment of origin. The current code language is often interpreted to mandate the exhaust method which no matter what rate of exhaust is provided, it cannot provide a tenable environment in the location of the fire origin.

A smoke control system is not required if operable or breakable windows are provided. There is no criteria for size or percentage of opening. Operable windows also can't provide a tenable environment within the area of origin. Provision of a smoke control system should not require a higher standard of protection than operable windows.

Cost Impact

The code change proposal will decrease the cost of construction .

Providing very high exhaust air changes can significantly increase the cost of construction.

Internal ID: 2289

G48-18

IBC: 202, 411, 411.1, , 411.2, 411.3, 411.4, 411.5, 411.6, 411.6.1, 411.7, TABLE 1017.2;

IFC: 914.7, 914.7.1, 914.7.2, 3103.3.1;

ICCPC: A103.1.9.12

Proponent: Angie Wiese, representing self (angie.wiese@ci.stpaul.mn.us)

2018 International Building Code

SECTION 202 DEFINITIONS

Revise as follows:

[BG] SPECIAL AMUSEMENT BUILDING-AREA. A special amusement ~~building-area~~ is any temporary or permanent building or portion thereof that is occupied for amusement, entertainment or educational purposes and ~~that contains a device or system that conveys passengers or provides a walkway along, around or over a course in any direction so arranged that the means of egress path is not readily apparent due to visual or audio distractions or is intentionally confounded or is not readily available because of the nature of the attraction or mode of conveyance through the building or structure is arranged in a manner that:~~

1. Makes the means of egress path not readily apparent due to visual or audio distractions.
2. Intentionally confounds identification of the means of egress path.
3. Otherwise makes the means of egress path not readily available because of the nature of the attraction or mode of conveyance through the building or structure.

Add new definition as follows:

PUZZLE ROOM A puzzle room is a type of special amusement area in which occupants are encouraged to solve a challenge to escape from a room or series of rooms.

Revise as follows:

SECTION 411 SPECIAL AMUSEMENT BUILDINGSAREAS

411.1 General. *Special amusement ~~buildingsareas~~ having an occupant load of 50 or more shall comply with the requirements for the appropriate Group A occupancy and Sections 411.1 through ~~411.7-411.8.~~ Special amusement ~~buildingsareas~~ having an occupant load of less than 50 shall comply with the requirements for a Group B occupancy and Sections 411.1 through ~~411.7-411.8.~~*

Exception: *Special amusement ~~buildingsareas~~ or portions thereof that are without walls or a roof and constructed to prevent the accumulation of smoke need not comply with this section.*

~~For flammable decorative materials, see the International Fire Code.~~

Delete without substitution:

~~**[F] 411.2 Automatic fire detection.** *Special amusement buildings shall be equipped with an automatic fire detection system in accordance with Section 907.*~~

Revise as follows:

[F] 411.2 Automatic sprinkler system. Buildings containing special amusement areas shall be equipped throughout with an automatic sprinkler system in accordance with Section 903.3.1.1. Where the special amusement area is temporary, the sprinkler water supply shall be of an approved temporary means.

Exception: Automatic sprinklers are not required where the total floor area of a temporary special amusement area is less than 1,000 square feet (93 m²) and the exit access travel distance from any point in the special amusement area to an exit is less than 50 feet (15 240 mm).

Add new text as follows:

411.3 Fire alarm system. Buildings containing special amusement areas shall be equipped with an automatic smoke detection system in accordance with 907.2.12.

Delete without substitution:

~~[F] 411.4 Alarm.~~ Actuation of a single ~~smoke detector~~, the ~~automatic sprinkler system~~ or other automatic fire detection device shall immediately sound an alarm at the building at a ~~constantly attended location~~ from which emergency action can be initiated including the capability of manual initiation of requirements in Section 907.2.11.

Revise as follows:

~~[F] 411.5-411.4 Emergency voice/alarm communications system.~~ An emergency voice/alarm communications system shall be provided in accordance with Sections 907.2.11 and 907.5.2.2, is permitted to serve as a public address system and shall be audible throughout the entire ~~special amusement building~~.

Add new text as follows:

411.5 Puzzle room exiting. Puzzle room exiting shall comply with one of the following:

1. Exiting in accordance with Chapter 10.
2. An alternative design approved by the building official.
3. Exit shall be open and readily available upon activation by the automatic fire alarm system, automatic sprinkler system, and a manual control at a constantly attended location.

Revise as follows:

411.6 Exit marking. Exit signs shall be installed at the required ~~exit~~ or ~~exit access doorways of serving special amusement buildings areas~~ in accordance with this section and Section 1013. ~~Approved~~ directional exit markings shall be provided. Where mirrors, mazes or other designs are utilized that disguise the path of egress travel such that they are not apparent, ~~approved~~ and listed low-level exit signs that comply with Section 1013.5, and directional path markings ~~listed~~ in accordance with UL 1994, shall be provided and located not more than 8 inches (203 mm) above the walking surface and on or near the path of egress travel. Such markings shall become visible in an emergency. The directional exit marking shall be activated by the automatic ~~fire-smoke~~ detection system and the ~~automatic sprinkler system~~ in accordance with Section 907.2.11.

411.6.1 Photoluminescent exit signs. Where ~~photoluminescent exit~~ signs are installed, activating light source and viewing distance shall be in accordance with the listing and markings of the signs.

411.7 Interior finish. The ~~interior finish~~ in special amusement areas shall be Class A in accordance with Section 803.1.

**TABLE 1017.2
EXIT ACCESS TRAVEL DISTANCE^a**

OCCUPANCY	WITHOUT SPRINKLER SYSTEM (feet)	WITH SPRINKLER SYSTEM (feet)
A, E, F-1, M, R, S-1	200 ^e	250 ^b
I-1	Not Permitted	250 ^b
B	200	300 ^c
F-2, S-2, U	300	400 ^c
H-1	Not Permitted	75 ^d
H-2	Not Permitted	100 ^d
H-3	Not Permitted	150 ^d
H-4	Not Permitted	175 ^d
H-5	Not Permitted	200 ^c
I-2, I-3	Not Permitted	200 ^c
I-4	150	200 ^c

For SI: 1 foot = 304.8 mm.

- a. See the following sections for modifications to *exit access* travel distance requirements:

Section 402.8: For the distance limitation in malls.

Section 404.9: For the distance limitation through an *atrium* space.

Section 407.4: For the distance limitation in Group I-2.

Sections 408.6.1 and 408.8.1: For the distance limitations in Group I-3.

Section ~~411.3~~411.2: For the distance limitation in special amusement ~~buildings~~ areas.

Section 412.6: For the distance limitations in aircraft manufacturing facilities.

Section 1006.2.2.2: For the distance limitation in refrigeration machinery rooms.

Section 1006.2.2.3: For the distance limitation in refrigerated rooms and spaces.

Section 1006.3.3: For buildings with one exit.

Section 1017.2.2: For increased distance limitation in Groups F-1 and S-1.

Section 1029.7: For increased limitation in assembly seating.

Section 3103.4: For temporary structures.

Section 3104.9: For pedestrian walkways.

- b. Buildings equipped throughout with an *automatic sprinkler system* in accordance with Section 903.3.1.1 or 903.3.1.2. See Section 903 for occupancies where *automatic sprinkler systems* are permitted in accordance with Section 903.3.1.2.
- c. Buildings equipped throughout with an *automatic sprinkler system* in accordance with Section 903.3.1.1.
- d. Group H occupancies equipped throughout with an *automatic sprinkler system* in accordance with Section 903.2.5.1.
- e. Group R-3 and R-4 buildings equipped throughout with an *automatic sprinkler system* in accordance with Section 903.3.1.3. See Section 903.2.8 for occupancies where automatic sprinkler systems are permitted in accordance with Section 903.3.1.3.

2018 International Fire Code

914.7 Special amusement ~~buildings~~ areas. Special amusement ~~buildings~~ areas shall comply with Sections 914.7.1 and 914.7.2.

914.7.1 Automatic sprinkler system. ~~Special Buildings containing special amusement buildings areas shall be~~ Special ~~Buildings~~ containing special amusement ~~buildings areas~~ areas shall be equipped throughout with an *automatic sprinkler system* in accordance with Section 903.3.1.1. Where the special amusement ~~building area~~ area is temporary, the sprinkler water supply shall be of an *approved* temporary means.

Exception: Automatic sprinklers are not required where the total floor area of a temporary special amusement ~~building area~~ area is less than 1,000 square feet (93 m²) and the *exit access* travel distance from any point in the special amusement area to an *exit* is less than 50 feet (15 240 mm).

914.7.2 Automatic smoke detection. Special amusement ~~buildings areas~~ areas shall be equipped with an automatic smoke detection system in accordance with Section 907.2.11.

3103.3.1 Special amusement ~~building area~~ area. Tents and other membrane structures erected as a special amusement ~~building area~~ area shall be equipped with an *automatic sprinkler system* in accordance with Section 411.3 of the International Building Code.

2018 International Code Council Performance Code

[BG] A103.1.9.12 SP-12, Special amusement ~~building area~~ area. A temporary, permanent or mobile area, building or structure that is occupied for amusement, entertainment or educational purposes and that contains a device or system that conveys passengers or provides a walkway along, around or over a course, in any direction, so arranged that means of egress are not readily apparent because of visual or audible distractions, or are intentionally confounded, or are not readily available because of the nature of the attraction or the mode of conveyance through the building or structure. It shall be assumed that:

1. Occupants, visitors and employees are awake, alert, predominantly able to exit without the assistance of others and unfamiliar with the area, building or structure.
2. Risk of injury and risk to health assumed by occupants, visitors and employees during their use of the area, building or structure are predominantly involuntary and high.
3. Public expectations regarding the protection afforded those occupying, visiting or working in such a an area, building, ~~or structure or portion thereof~~ are high.

Reason:

Puzzle rooms are a new business model where people are placed in a room and asked either to find a way out of the room or to find their way to the next room in the puzzle. The rooms are typically small and might otherwise be classified as a B occupancy under the current code. Each of these are designed in a way to provide a unique experience for the customer. This unique design incorporates a number of possible features to disorient the occupants and/or disguise the exit route. Such a design is contrary to the foundations of code specified exiting provisions.

This proposal seeks to establish criteria for puzzle rooms by incorporating them into the special amusement section. Since part of the appeal of this business model is that each experience is different, there is no way to prescriptively handle every situation. The language is fairly generic but gives guidance on providing reliable exiting in an emergency.

While researching this proposal, it was recognized that the special amusement building section needed some updating. The word "building" is changed to "area" and the fire alarm provisions were rewritten to correlate with section 907 of the fire code.

Cost Impact

The code change proposal will increase the cost of construction .

Many of these rooms may be classified currently as a B occupancy as they are not specifically called out in the code. As such, there are very little requirements for fire alarm or sprinkler systems. Depending on the size and configuration of the room(s), this provision would increase the cost of construction.

Internal ID: 299

G49-18

IBC: [F]415.6, 415.6.1(New), 415.6.2(New), 415.6.3(New), 507.8.1.1.1, 507.8.1.1.2

Proponent: Tracie Dutter, Livermore-Pleasanton Fire Department, representing California Fire Chief's Association

THIS CODE CHANGE WILL BE HEARD BY THE FIRE CODE COMMITTEE. SEE THE TENTATIVE HEARING ORDER FOR THIS COMMITTEE

2018 International Building Code

Revise as follows:

[F] 415.6 Fire separation distance. Group H occupancies shall be located on property in accordance with the other provisions of this chapter. In Groups H-2 and H-3, not less than 25 percent of the perimeter wall of the occupancy shall be an *exterior wall*.

Exceptions:

1. ~~Liquid use, dispensing and mixing rooms having a floor area of not more than 500 square feet (46.5 m²) need not be located on the outer perimeter of the building where they are in accordance with the International Fire Code and NFPA 30.~~
2. ~~Liquid storage rooms having a floor area of not more than 1,000 square feet (93 m²) need not be located on the outer perimeter where they are in accordance with the International Fire Code and NFPA 30.~~
3. ~~Spray paint booths that comply with the International Fire Code need not be located on the outer perimeter.~~

Add new text as follows:

415.6.1 Liquid use, dispensing and mixing rooms and rooms for flammable or combustible liquid use, dispensing or mixing in open systems. Liquid use, dispensing and mixing rooms and rooms for flammable or combustible liquid use, dispensing or mixing in open systems, where vapors are emitted, having a floor area of not more than 500 square feet (46.5 m²) need not be located on the outer perimeter of the building where they are in accordance with the International Fire Code and NFPA 30.

415.6.2 Liquid storage rooms and rooms for flammable or combustible liquid use in closed systems. Liquid storage rooms and rooms for flammable or combustible liquid use in closed systems, where no vapors are emitted, having a floor area of not more than 1,000 square feet (93 m²) need not be located on the outer perimeter where they are in accordance with the International Fire Code and NFPA 30.

415.6.3 Spray paint booths. Spray paint booths that comply with the International Fire Code need not be located on the outer perimeter.

Revise as follows:

507.8.1.1.1 Liquid use, dispensing and mixing ~~rooms,~~ rooms and rooms for flammable or combustible liquid use dispensing or mixing in open systems. Liquid use, dispensing and mixing ~~rooms and~~ rooms for flammable or combustible liquid use, dispensing or mixing in open systems, where vapors are emitted, and having a floor area of not more than 500 square feet (46.5 m²) need not be located on the outer perimeter of the building where they are in accordance with the International Fire Code and NFPA 30.

507.8.1.1.2 Liquid storage ~~rooms,~~ rooms and rooms for flammable or combustible liquid use in closed systems. Liquid storage ~~rooms and~~ rooms for flammable or combustible liquid use in closed systems, where no vapors are emitted, having a floor area of not more than 1,000 square feet (93 m²) need not be located on the outer perimeter where they are in accordance with the International Fire Code and NFPA 30.

Reason:

The code currently addresses liquid use, dispensing and mixing rooms with open containers and storage rooms with closed containers, but it is silent on rooms with closed systems. The intent of this code change proposal is to limit the size of rooms with flammable or combustible liquid use in closed systems, when the rooms do not have 25 percent of their perimeter on an exterior wall.

Liquid use, dispensing and mixing room is defined in Chapter 2 as a room in which Class I, II and IIIA flammable or combustible liquids are used, dispensed or mixed in open containers. Liquid storage room is defined in Chapter 2 as a room classified as a Group H-3 occupancy used for the storage of flammable or combustible liquids in a closed condition.

A closed system is defined in Chapter 2 as the use of a solid or liquid hazardous material involving a closed vessel or system that remains closed during normal operations where vapors emitted by the product are not liberated outside of the vessel or system and the product is not exposed to the atmosphere during normal operations; and all uses of compressed gases. Examples of closed systems for solids and liquids include product conveyed through a piping system into a closed vessel, system or piece of equipment.

Recent projects have highlighted the fact that this code section currently only places limits on the size of rooms not on an exterior wall if they have open use, dispensing or mixing and if they have closed containers in storage. However, it does not address flammable or combustible liquid use in rooms with closed systems. Some applicants do not want to have 25 percent of the perimeter of a large H-3 occupancy with a closed system on an exterior wall. According to an ICC technical opinion about an unlimited area building: As discussed earlier, the code is silent about the extent of use-closed (process) systems involving flammable liquids in an unlimited area building when 25% of exterior wall access along the perimeter is not available. Admittedly, in your case, some perimeter access was still available but less than 25%. In addition, the proposed overall area of the "interior" Group H occupancy (process system) was within the permitted 25% allowed for interior Group H occupancies. With that being said, we also discussed the relative hazard of the proposed process system and the lack of a specific direct correlation with the requirements for inside storage and dispensing rooms. As such, final evaluation of the proposed operation is subject to the code official.

The hazard of flammable or combustible liquids in closed use is between open use and closed storage. In general it is more similar to closed storage, although sometimes flammable or combustible liquids in closed systems are pressurized, which can increase the hazard. This code change proposal would limit the size of rooms with flammable or combustible liquids in closed use systems, in the same way it limits the size of liquid storage rooms. This is consistent with the International Fire Code Chapter 50, Table 5003.1.1(1) which limits the amounts of flammable and combustible liquids in closed systems the same way it limits the amounts of flammable and combustible liquids in storage.

Specifying the limitations for rooms with flammable or combustible liquids in closed use will allow for better customer service. It will eliminate uncertainty for the code official and provide better consistency for applicants.

As part of this code change proposal, the code language in IBC 415.6 was made the rule instead of the exception, as in IBC 507.8.1.1.2.

Cost Impact

The code change proposal will not increase or decrease the cost of construction .

The code is not clear in this area, so this code change proposal is to clarify the requirements to what it most closely resembles and what most jurisdictions enforce.

Internal ID: 1018

G50-18

IBC: 415.7 (New), 415.7.1 (New), 415.7.2 (New), 415.7.3 (New), 415.7.4 (New), 415.7.5 (New), 415.7.6 (New)

Proponent: Tracie Dutter, Livermore-Pleasanton Fire Department, representing California Fire Chief's Association

THIS CODE CHANGE WILL BE HEARD BY THE FIRE CODE COMMITTEE. SEE THE TENTATIVE HEARING ORDER FOR THIS COMMITTEE

2018 International Building Code

Add new text as follows:

415.7 Fire department access doors. Fire department access doors shall be provided in Group H occupancies in accordance with Sections 415.7.1 through 415.7.6

415.7.1 General. Grade level Group H occupancies required to have not less than 25 percent of the perimeter of the occupancy on an exterior wall shall have at least one exterior door in an approved location for fire department access.

415.7.2 Access to doors. Fire department access doors shall be able to be accessed without the use of a ladder.

415.7.3 Labeled. Fire department access doors shall be labeled on the exterior side with a sign that reads: "FIRE DEPARTMENT ACCESS DOOR DO NOT BLOCK" or other approved sign. Letters shall be a minimum height of 2 inches (51 mm) with a minimum stroke of 3/8 inch (10 mm) and on a contrasting background.

415.7.4 Door size and type. Fire department access doors shall be not less than 3 feet (914 mm) in width and 6 feet 8 inches (2032 mm) in height. Roll up doors shall not be considered fire department access doors unless approved.

415.7.5 Locking devices. Locking devices on fire department access doors shall be approved.

415.7.6 Key box. Where fire department access doors are required, a key box shall be installed in accordance with Section 506.1 of the International Fire Code. The key box shall contain keys or devices to allow for entry through the fire department access doors.

Reason:

This section specifies when Group H occupancies are required to have their perimeter on an exterior wall. According to the International Building Code Commentary, Section 415.6, this is "in order to provide adequate access for fire-fighting operations and venting of the products of combustion..." Also, Section 507.8.2 states "more ready access to the high-hazard occupancy from the exterior of the building gives the fire department the opportunity to respond more effectively to an incident." Applicants with large H occupancies don't always plan for an exterior door in the H room. Or if there is a door, it's not always in a location that allows for fire department access. Designers have pointed out that although the code requires the H occupancy to be on an exterior wall, the code does not require a door for fire department access. Since the intent of this section is to give the fire department access to the high-hazard occupancy from the exterior of the building, the fire code official should have the ability to require an exterior door in a location approved for fire department access. One of the legacy codes required an exterior access door for Liquid Use, Dispensing and Mixing Rooms and Liquid Storage Rooms over 500 square feet, but that requirement did not make the transition to the International Building Code. The code commentary does not address why it was not included in the International Building Code. This code change proposal would re-establish that requirement.

To be consistent with other parts of the code, the requirements for the fire department access door are consistent with the requirements for fire department access doors in the International Fire Code, Chapter 32, Section 3206.7.

Cost Impact

The code change proposal will increase the cost of construction .

If the applicant did not already plan to install an exterior door in the H occupancy room, this code change proposal will increase the cost of construction by the cost to install an exterior door. If the applicant is moving into an existing building, there may be an existing door that would work for fire department access. So in some cases there would be no change in the cost of construction and in other cases there would be a minimal cost increase.

Internal ID: 1015

G51-18

IBC: [F]415.9, [F]415.9.1, [F]415.9.1.1, [F]415.9.1.1.1, [F]415.9.1.2, [F]415.9.1.3, [F]415.9.1.4, [F]415.9.1.5, [F]415.9.1.6, [F]415.9.1.7, [F]415.9.1.8, [F]415.9.1.9, [F]415.9.2, [F]415.9.3, [F]415.10, [F]415.10.1, [F]415.10.2, [F]415.10.3, [F]415.10.4

Proponent: Ellie Klausbruckner, Klausbruckner & Associates Inc., representing Klausbruckner & Associates, Inc. (ek@klausbruckner.com)

THIS CODE CHANGE WILL BE HEARD BY THE FIRE CODE COMMITTEE. SEE THE TENTATIVE HEARING ORDER FOR THIS COMMITTEE

2018 International Building Code

Revise as follows:

[F] 415.9 Group H-2, H-3 and H-4. Occupancies in Group H-2, H-3 and H-4 shall be constructed in accordance with Sections 415.9.1 through 415.9.3 the applicable provisions of this code, the International Mechanical Code and the International Fire Code.

[F] 415.9.1 Flammable and combustible liquids. The storage, handling, processing and transporting of flammable and combustible liquids in Group H-2 and H-3 occupancies shall be in accordance with Sections 415.9.1.1 through 415.9.1.9 the applicable provisions of this chapter, the International Mechanical Code and the International Fire Code.

Add new text as follows:

415.9.1.1 Flammable and combustible liquid tanks. The storage of flammable and combustible liquids in stationary tanks utilized for associated operations of building equipment or machinery in Group H-2 and H-3 occupancies, where the storage tank is located in a building of two or more occupancies, is not subject to height limitations of Section 504 where the following conditions exist:

1. The H-2 or H-3 use is separated from adjacent occupancies in accordance with the requirements of Section 508.4.
2. Where the storage tank is located within not more than one story of the building.
3. Where the tank and the room is designed, installed and protected in accordance with Sections 415.9.1.1.1 through 415.9.1.1.8.

Delete without substitution:

[F] 415.9.1.1 Mixed occupancies. ~~Where the storage tank area is located in a building of two or more occupancies and the quantity of liquid exceeds the maximum allowable quantity for one control area, the use shall be completely separated from adjacent occupancies in accordance with the requirements of Section 508.4.~~

[F] 415.9.1.1.1 Height exception. ~~Where storage tanks are located within a building not more than one story above grade plane, the height limitation of Section 504 shall not apply for Group H.~~

Revise as follows:

[F] 415.9.1.2 415.9.1.1.1 Tank protection. Storage tanks shall be noncombustible and protected from physical damage. *Fire barriers or horizontal assemblies* or both around the storage tanks shall be permitted as the method of protection from physical damage.

[F] 415.9.1.3 415.9.1.1.2 Tanks. Storage tanks shall be approved tanks conforming to the requirements of the International Fire Code.

[F] 415.9.1.4 415.9.1.1.3 Leakage containment. A liquid-tight containment area compatible with the stored liquid shall be provided. The method of spill control, drainage control and secondary containment shall be in accordance with the International Fire Code.

Exception: Rooms where only double-wall storage tanks conforming to Section 415.9.1.3 are used to store Class I, II and IIIA flammable and combustible liquids shall not be required to have a leakage containment area.

[F] ~~415.9.1.5~~ 415.9.1.1.4 Leakage alarm. An *approved* automatic alarm shall be provided to indicate a leak in a storage tank and room. The alarm shall sound an audible signal, 15 dBA above the ambient sound level, at every point of entry into the room in which the leaking storage tank is located. An *approved* sign shall be posted on every entry door to the tank storage room indicating the potential hazard of the interior room environment, or the sign shall state: WARNING, WHEN ALARM SOUNDS, THE ENVIRONMENT WITHIN THE ROOM MAY BE HAZARDOUS. The leakage alarm shall be supervised in accordance with Chapter 9 to transmit a trouble signal.

[F] ~~415.9.1.6~~ 415.9.1.1.5 Tank vent. Storage tank vents for Class I, II or IIIA liquids shall terminate to the outdoor air in accordance with the International Fire Code.

[F] ~~415.9.1.7~~ 415.9.1.1.6 Room ventilation. Storage tank areas storing Class I, II or IIIA liquids shall be provided with mechanical *ventilation*. The mechanical *ventilation system* shall be in accordance with the International Mechanical Code and the International Fire Code.

[F] ~~415.9.1.8~~ 415.9.1.1.7 Explosion venting. Where Class I liquids are being stored, explosion venting shall be provided in accordance with the International Fire Code.

[F] ~~415.9.1.9~~ 415.9.1.1.8 Tank openings other than vents. Tank openings other than vents from tanks inside buildings shall be designed to ensure that liquids or vapor concentrations are not released inside the building.

[F] 415.9.2 Liquefied petroleum gas facilities. The construction and installation of liquefied petroleum gas facilities shall be in accordance with the requirements of this code, the International Fire Code, the International Mechanical Code, the International Fuel Gas Code and NFPA 58.

[F] 415.9.3 Dry cleaning plants. The construction and installation of dry cleaning plants shall be in accordance with the requirements of this code, the International Mechanical Code, the International Plumbing Code and NFPA 32. Dry cleaning solvents and systems shall be classified in accordance with the International Fire Code.

Delete without substitution:

~~[F] 415.10 Groups H-3 and H-4.~~ Groups H-3 and H-4 shall be constructed in accordance with the applicable provisions of this code and the International Fire Code.

~~[F] 415.10.1 Flammable and combustible liquids.~~ The storage, handling, processing and transporting of flammable and combustible liquids in Group H-3 occupancies shall be in accordance with Section 415.9.1.

Revise as follows:

[F] ~~415.10.2~~ 415.9.4 Gas rooms. Where gas rooms are provided, such rooms shall be separated from other areas by not less than 1-hour *fire barriers* constructed in accordance with Section 707 or *horizontal assemblies* constructed in accordance with Section 711, or both.

[F] ~~415.10.3~~ 415.9.5 Floors in storage rooms. Floors in storage areas for corrosive liquids and highly toxic or toxic materials shall be of liquid-tight, noncombustible construction.

[F] ~~415.10.4~~ 415.9.6 Separation of highly toxic solids and liquids. Highly toxic solids and liquids not stored in *approved* hazardous materials storage cabinets shall be isolated from other hazardous materials storage by not less than 1-hour fire barriers constructed in accordance with Section 707 or *horizontal assemblies* constructed in accordance with Section 711, or both.

Reason:

The original code sections in 415.9.1 came from the BOCA Building Code. It is our understanding that the intent was to allow tanks inside the building at a time when they were not allowed by NFPA 30. As an example a generator or fire pump, along with the associated diesel fuel tank could be allowed in the basement of a building. The room housing the tank would not be subject to height limitations if the tank and the room housing the tank was only one story tall. Please see attached original BOCA Building Code language. At some point, a decision was made to replace language such as "one story" to "one story above grade plane" throughout the code for other reasons such as consistency (e.g. in allowable area sections in Chapter 5). The language in this section accidentally changed from "one story" meaning the tank is only on a single floor to "one story above grade" in 415.9.1.1.1. The proposed code change clarifies the original intent of this code section. Also the language used to imply that the H-Occupancy is allowed on the different floors regardless of what else may be in the room. It is intended for tanks used for servicing building equipment. The

language as it is currently written implies facilities (such as major chemical manufacturing, etc.) with tanks can be on upper floors which is not the intent of this section.

418.2.1 Construction: Occupancies in Use Group H-1 shall not be located in buildings that are more than one story in height, have basements or other spaces below grade, or which are attached to other buildings. The minimum fire separation distance for all exterior walls of occupancies in Use Group H-1 shall be in accordance with the fire prevention code listed in Chapter 35. All floor surfaces shall be spark resistant.

418.2.2 Number of exits: There shall not be less than two exits from any area or space wherein Use Group H-1 materials are utilized or stored. All required exits shall discharge directly to the exterior of the building or structure.

418.3 Use Group H-2: Occupancies in Use Group H-2 shall be constructed in accordance with Sections 418.3.1 through 418.3.4 and the fire prevention code listed in Chapter 35.

418.3.1 Combustible dusts, grain processing and storage: The provisions of Sections 418.3.1.1 through 418.3.1.6 shall apply to all buildings in which materials that produce combustible dusts are stored or handled. Buildings which store or handle combustible dusts shall comply with the applicable provisions of NFPA 61, 65, 120, 651, 654, 655, 664 and 8503 and the fire prevention code listed in Chapter 35.

418.3.1.1 Type of construction and height exceptions: All buildings shall be of Type 1, Type 2 or Type 4 construction, within the height and area limitations of Table 503 for Use Group H-2; except that where erected of Type 1 or Type 2 construction, the heights and areas of grain elevators and similar structures shall be unlimited, and where of Type 4 construction, the maximum height shall be 65 feet (19812 mm) and except further that, in isolated areas, the maximum height of Type 4 structures shall be increased to 85 feet (25908 mm).

418.3.1.2 Grinding rooms: Every room or space occupied for grinding or other operations that produce combustible dusts shall be enclosed with floors and walls that have not less than a 2-hour fire-resistance rating where the area is not more than 3,000 square feet (279 m²), and not less than a 4-hour fire-resistance rating where the area is greater than 3,000 square feet (279 m²).

418.3.1.3 Conveyors: All conveyors, chutes, piping and similar equipment passing through the enclosures of rooms or spaces shall be constructed fire tight and vapor tight, and be of approved noncombustible materials complying with Section 3010.0.

418.3.1.4 Explosion relief: Means for explosion relief shall be provided as specified in Section 417.5.1, or spaces shall be equipped with the equivalent mechanical ventilation complying with the mechanical code listed in Chapter 35.

418.3.1.5 Grain elevators: Grain elevators, tank houses and buildings for similar occupancies shall not be located within 30 feet (9144 mm) of interior lot lines or structures on the same lot, except where erected along a railroad right-of-way.

418.3.1.6 Coal pockets: Coal pockets located less than 30 feet (9144 mm) from interior lot lines or from structures on the same lot shall be constructed of not less than Type

2A construction. Where more than 30 feet (9144 mm) from interior lot lines, or where erected along a railroad right-of-way, the minimum type of construction of such structures not more than 65 feet (19812 mm) in height shall be Type 4.

418.3.2 Flammable and combustible liquids: The storage, handling, processing and transporting of flammable and combustible liquids shall be in accordance with the mechanical code and the fire prevention code listed in Chapter 35. Where a Class I, II or IIIA flammable or combustible liquid is stored in tanks inside the building, the installation shall conform to Sections 418.3.2.1 through 418.3.2.10 and NFPA 30 listed in Chapter 35. The requirements shall only apply where tanks have an individual storage capacity that exceeds the exempt amounts specified in Tables 307.8(1) and 307.8(2). The fire area containing the tank(s) shall be classified as Use Group H-2.

418.3.2.1 Mixed use groups: Where the storage tank area is located in a building of two or more use groups, the Use Group H-2 fire area shall be completely separated from adjacent fire areas in accordance with the requirements of Section 313.1.2.

418.3.2.1.1 Height exception: Where storage tanks are located within only a single story, the height limitation of Section 503.3 shall not apply for the Use Group H-2 fire area.

418.3.2.2 Tank protection: All storage tanks shall be noncombustible and protected from physical damage. A fire separation assembly around the storage tank(s) shall be permitted to be classified as the method of protection from physical damage.

418.3.2.3 Tanks for Class I flammable liquid: All storage tanks for Class I flammable liquid shall be double-walled tanks. A double-walled tank shall consist of an approved tank conforming to the requirements of the fire prevention code listed in Chapter 35, installed within a completely enclosed noncombustible containment structure. The containment structure shall prevent the stored liquid from escaping into the room or area in which the tank is located. A leak detection alarm shall be provided to identify a leak of the primary wall of the tank. The alarm shall conform to Section 418.3.2.6.

418.3.2.4 Suppression: The Use Group H-2 fire area shall be equipped throughout with an approved automatic fire sprinkler system, installed in accordance with Section 906.2.1, or with a foam-extinguishing system. The automatic fire suppression system shall be supervised by method 1 of Section 924.1.

418.3.2.5 Leakage containment: A liquid-tight containment area compatible with the stored liquid shall be provided to retain 110 percent of the entire capacity of all the storage liquid in the event of a leak in a tank plus the capacity of the automatic fire suppression system activated for a period of 30 minutes. The storage tanks and the leakage containment area shall be provided with an ap-

proved method to drain manually the flammable or combustible liquid.

Exception: Rooms where only double-wall storage tanks conforming to Section 418.3.2.3 are used to store Class I, II and IIIA flammable and combustible liquids shall not be required to have a leakage containment area.

418.3.2.6 Leakage alarm: An approved automatic alarm shall be provided to indicate a leak in a storage tank and room. The alarm shall sound an audible signal, 15 dBA above the ambient sound level, at every point of entry into the room in which the leaking storage tank is located. An approved sign shall be posted on every entry door to the tank storage room indicating the potential hazard of the interior room environment, or the sign shall state, "Warning, when alarm sounds, the environment within the room may be hazardous." The leakage alarm shall also be supervised in accordance with Section 924.2 to transmit a trouble signal.

418.3.2.7 Tank vent: Storage tank vents shall terminate to the outdoor air. The vent termination shall be in an approved location a minimum of 12 feet (3658 mm) above adjacent ground level and 10 feet (3048 mm) from a door, window, ventilation intake opening, operable window or door.

418.3.2.8 Room ventilation: Storage tank areas storing Class I liquids, or Class II or IIIA liquids at temperatures above flash point, shall be ventilated at a rate sufficient to maintain the concentration of vapors within the area at or below 25 percent of the lower explosive limit. Ventilation requirements shall be determined by either calculations based on anticipated fugitive emissions or by sampling of the actual vapor concentration levels under normal operating conditions. The sampling shall be conducted at a 5-foot radius from each potential vapor source in the storage area. Provision shall be made for make-up air to avoid short-circuiting the ventilation.

418.3.2.9 Explosion venting: Where Class I liquids are being stored, explosion venting shall be provided in accordance with Section 417.5.

418.3.2.10 Tank openings other than vents: Tank openings other than vents from tanks inside buildings shall be designed to ensure that liquids or vapor concentrations are not released inside the building and shall conform to Sections 418.3.2.10.1 through 418.3.2.10.5.

418.3.2.10.1 Liquid tight: All tank openings at the maximum liquid level or below shall be liquid tight.

418.3.2.10.2 Closed: All tank openings above the maximum liquid level shall be normally closed.

418.3.2.10.3 External valve: Each connection through which liquid is capable of gravity flow from a tank inside a building shall be provided with an external valve located as close as practical to, but not more than 2 feet from, the shell of the tank.

418.3.2.10.4 Valves on transfer connections: Tanks storing Class I or Class II liquids shall be provided with

either a normally closed, remotely activated valve or an automatic-closing, heat-activated valve or other approved device on each liquid transfer connection below the liquid level, except for connections utilized for emergency disposal.

418.3.2.10.5 Overflow protection: Tanks shall be equipped with a device, or other means provided, to prevent overflow into the building.

418.3.3 Liquefied petroleum gas distribution facilities: The design and construction of propane, butane, propylene, butylene and other liquefied petroleum gas distribution facilities shall conform to the applicable provisions of Sections 418.3.3.1 through 418.3.3.2. The storage and handling of liquefied petroleum gas systems shall conform to the fire prevention code listed in Chapter 35. The design and installation of piping, equipment and systems which utilize liquefied petroleum gas shall be in accordance with the mechanical code listed in Chapter 35. Liquefied petroleum gas distribution facilities shall be ventilated in accordance with the mechanical code listed in Chapter 35 and Section 418.3.3.1.

418.3.3.1 Air movement: Liquefied petroleum gas distribution facilities shall be provided with air inlets and outlets arranged so that air movement across the floor of the facility will be uniform. The total area of both inlet and outlet openings shall be at least 1 square inch (645 mm²) for each 1 square foot (0.093 m²) of floor area. The bottom of such openings shall not be more than 6 inches (152 mm) above the floor.

418.3.3.2 Construction: Liquefied petroleum gas distribution facilities shall be constructed in accordance with Section 418.3.3.3 for separate buildings, Section 418.3.3.4 for attached buildings or Section 418.3.3.5 for rooms within buildings.

418.3.3.3 Separate buildings: Where located in separate buildings, liquefied petroleum gas distribution facilities shall be occupied exclusively for that purpose or for other purposes having similar hazards. Such buildings shall be limited to one story in height and shall conform to Sections 418.3.3.3.1 and 418.3.3.3.2.

418.3.3.3.1 Floors: The floor shall not be located below ground level and any spaces beneath the floor shall be solidly filled or shall be left unenclosed.

418.3.3.3.2 Materials: Walls, floors, ceilings, columns and roofs shall be constructed of noncombustible materials. Exterior walls, ceilings and roofs shall be constructed of material designed for explosion venting or, if of heavy construction such as solid brick masonry, concrete block or concrete, explosion-venting windows or panels in walls or roofs shall be provided having an explosion-venting area of at least 1 square foot (0.093 m²) for each 50 cubic feet (1.40 m³) of enclosed volume.

418.3.3.4 Attached buildings: Where liquefied petroleum gas distribution facilities are located in an attached structure, the attached perimeter shall not exceed 50 percent of the perimeter of the space enclosed and the facility shall comply with Sections 418.3.3.3 and 418.3.3.4.1. Where

Cost Impact

The code change proposal will not increase or decrease the cost of construction.

This is an editorial change to clean up the language and clarify what was intended by the code sections.

Internal ID: 1776

G52-18

IBC: [F]415.11.3.5, [F]415.11.3.5.1, [F]415.11.3.5.2, [F]415.11.3.5.3, [F]415.11.3.5.4, [F]415.11.3.5.5

Proponent: Patrick McLaughlin, representing Self (pmclaugma@aol.com)

THIS CODE CHANGE WILL BE HEARD BY THE FIRE CODE COMMITTEE. SEE THE TENTATIVE HEARING ORDER FOR THIS COMMITTEE

2018 International Building Code

Revise as follows:

[F] ~~415.11.3.5~~ **415.11.4 Emergency alarm system.** *Emergency alarm systems* shall be provided in accordance with this section and Sections 415.5.1 and ~~415.5.2~~ 415.5.2. The maximum allowable quantity per *control area* provisions shall not apply to *emergency alarm systems* required for HPM.

[F] ~~415.11.3.5.1~~ **415.11.4.1 Service corridors.** An *emergency alarm system* shall be provided in *service corridors*, with not fewer than one alarm device in each *service corridor*.

[F] ~~415.11.3.5.2~~ **415.11.4.2 Corridors and interior exit stairways and ramps.** Emergency alarms for *corridors*, *interior exit stairways* and *ramps* and *exit passageways* shall comply with Section ~~415.5.2~~ 415.5.2.

[F] ~~415.11.3.5.3~~ **415.11.4.3 Liquid storage rooms, HPM rooms and gas rooms.** Emergency alarms for liquid storage rooms, HPM rooms and gas rooms shall comply with Section ~~415.5.1~~ 415.5.1.

[F] ~~415.11.3.5.4~~ **415.11.4.4 Alarm-initiating devices.** An *approved* emergency telephone system, local alarm manual pull stations, or other *approved* alarm-initiating devices are allowed to be used as emergency alarm-initiating devices.

[F] ~~415.11.3.5.5~~ **415.11.4.5 Alarm signals.** Activation of the *emergency alarm system* shall sound a local alarm and transmit a signal to the emergency control station.

Reason:

This proposal simply pulls the emergency alarm requirements for semi-conductors out of the section on Service corridors. This is simply an editorial change as the emergency alarm system requirements should stand on their own.

Cost Impact

The code change proposal will not increase or decrease the cost of construction .

This truly is a clarification and clean up of the code to properly place emergency alarm systems in their own subsection outside of the requirements for service corridors.

Internal ID: 282

G53-18

IBC: 420.4 (New)

Proponent: Sarah Rice, representing Myself (srice@preview-group.com)

2018 International Building Code

Add new text as follows:

420.4 Fire-resistance rating. Fire partitions and horizontal assemblies separating dwelling or sleeping units in the same building, and dwelling or sleeping units from other occupancies shall have a fire-resistance rating of not less than 1 hour.

Exception: Dwelling unit and sleeping unit separations in buildings of Types IIB, IIIB and VB construction shall have fire-resistance ratings of not less than 1/2 hour in buildings equipped throughout with an automatic sprinkler system in accordance with Section 903.3.1.1.

Reason:

Section 420 is where the requirement for dwelling and sleeping units to be separated from each other and other occupancies is found. Currently it tells the code user that the walls must be fire partitions and the floors must be horizontal assemblies, but in order to know what the fire ratings are to these assemblies you are forced to go to Sections 708.3 and 711.2.3. This code change proposes to bring the fire ratings into Section 420.

708.3 Fire-resistance rating. Fire partitions shall have a fire-resistance rating of not less than 1 hour.

Exceptions:

1. Corridor walls permitted to have a 1/2-hour fire resistance rating by Table 1020.1.
2. Dwelling unit and sleeping unit separations in buildings of Types IIB, IIIB and VB construction shall have fire-resistance ratings of not less than 1/2 hour in buildings equipped throughout with an automatic sprinkler system in accordance with Section 903.3.1.1.

Dwelling unit and sleeping unit separations in buildings of Types IIB, IIIB and VB construction shall have fire-resistance ratings of not less than 1/2 hour in buildings equipped throughout with an automatic sprinkler system in accordance with Section 903.3.1.1.

711.2.3 Supporting construction. The supporting construction shall be protected to afford the required fire resistance rating of the horizontal assembly supported.

Exception: In buildings of Type IIB, IIIB or VB construction, the construction supporting the horizontal assembly is not required to be fire-resistance rated at the following:

1. Horizontal assemblies at the separations of incidental uses as specified by Table 509 provided that the required fire-resistance rating does not exceed 1 hour.
2. Horizontal assemblies at the separations of dwelling units and sleeping units as required by Section 420.3.
3. Horizontal assemblies at smoke barriers constructed in accordance with Section 709.

Cost Impact

The code change proposal will not increase or decrease the cost of construction .

This is simply a correlative code change, duplicating information found in another section of the code.

Internal ID: 2376

G54-18

IBC: 420.2, 705.3

Proponent: Micah Chappell, representing City of Seattle (micah.chappell@seattle.gov)

2018 International Building Code

Revise as follows:

420.2 Separation walls. Walls separating *dwelling units* in the same building, walls separating *sleeping units* in the same building and walls separating *dwelling* or *sleeping units* from other occupancies contiguous to them in the same building shall be constructed as *fire partitions* in accordance with Section 708. Exterior walls separating units shall comply with Section 705.3.

Exceptions:

1. Where sleeping units include private bathrooms, walls between bedrooms and the associated private bathrooms are not required to be constructed as fire partitions.
2. Where sleeping units are constructed as suites, walls between bedrooms within the sleeping unit and the walls between the bedrooms and associated living spaces are not required to be constructed as fire partitions.
3. In Group R-3 and R-4 facilities, walls within the dwelling units or sleeping units are not required to be constructed as fire partitions.

705.3 Buildings on the same lot. For the purposes of determining the required wall and opening protection, projections and roof-covering requirements, buildings on the same lot and portions of the same building requiring dwelling or sleeping unit separation shall be assumed to have an imaginary line between them. Section 705.3 Exception 1 shall not be used where dwelling or sleeping unit separation is required.

Where a new building is to be erected on the same lot as an existing building, the location of the assumed imaginary line with relation to the existing building shall be such that the *exterior wall* and opening protection of the existing building meet the criteria as set forth in Sections 705.5 and 705.8.

Exceptions:

1. Two or more buildings on the same lot shall be either regulated as separate buildings or shall be considered as portions of one building if the aggregate area of such buildings is within the limits specified in Chapter 5 for a single building. Where the buildings contain different occupancy groups or are of different types of construction, the area shall be that allowed for the most restrictive occupancy or construction.
2. Where an S-2 parking garage of Construction Type I or IIA is erected on the same lot as a Group R-2 building, and there is no *fire separation distance* between these buildings, then the adjoining *exterior walls* between the buildings are permitted to have occupant use openings in accordance with Section 706.8. However, opening protectives in such openings shall only be required in the exterior wall of the S-2 parking garage, not in the exterior wall openings in the R-2 building, and these opening protectives in the exterior wall of the S-2 parking garage shall be not less than 1¹/₂-hour *fire protection rating*.

Reason:

The code requires fire-rated construction between dwelling units, but does not specifically address the situation where the separating wall is exterior. The provisions of 705.3 establish a means to determine the required fire rating and allowable openings for exterior walls of two buildings on the same lot. The same principles should be applied to the requirements for dwelling unit separation.

Dwelling unit separation is intended to prevent a fire in one unit from spreading to other units in a building. If adjacent units have unprotected openings in close proximity, fire can more readily spread between units, and to exterior balconies, cladding and roof.

With increasing demand for greater density housing, architects are designing more multifamily residential buildings with smaller units, often with windows on opposite sides of courts.

The provisions of Section 1206 control the minimum sizes of courts, but are silent on the fire-rating requirements, as this section is focused on light and ventilation.

This revision will provide greater clarity for designers and increased safety and privacy for building residents.

Plan Review Calculations DPD

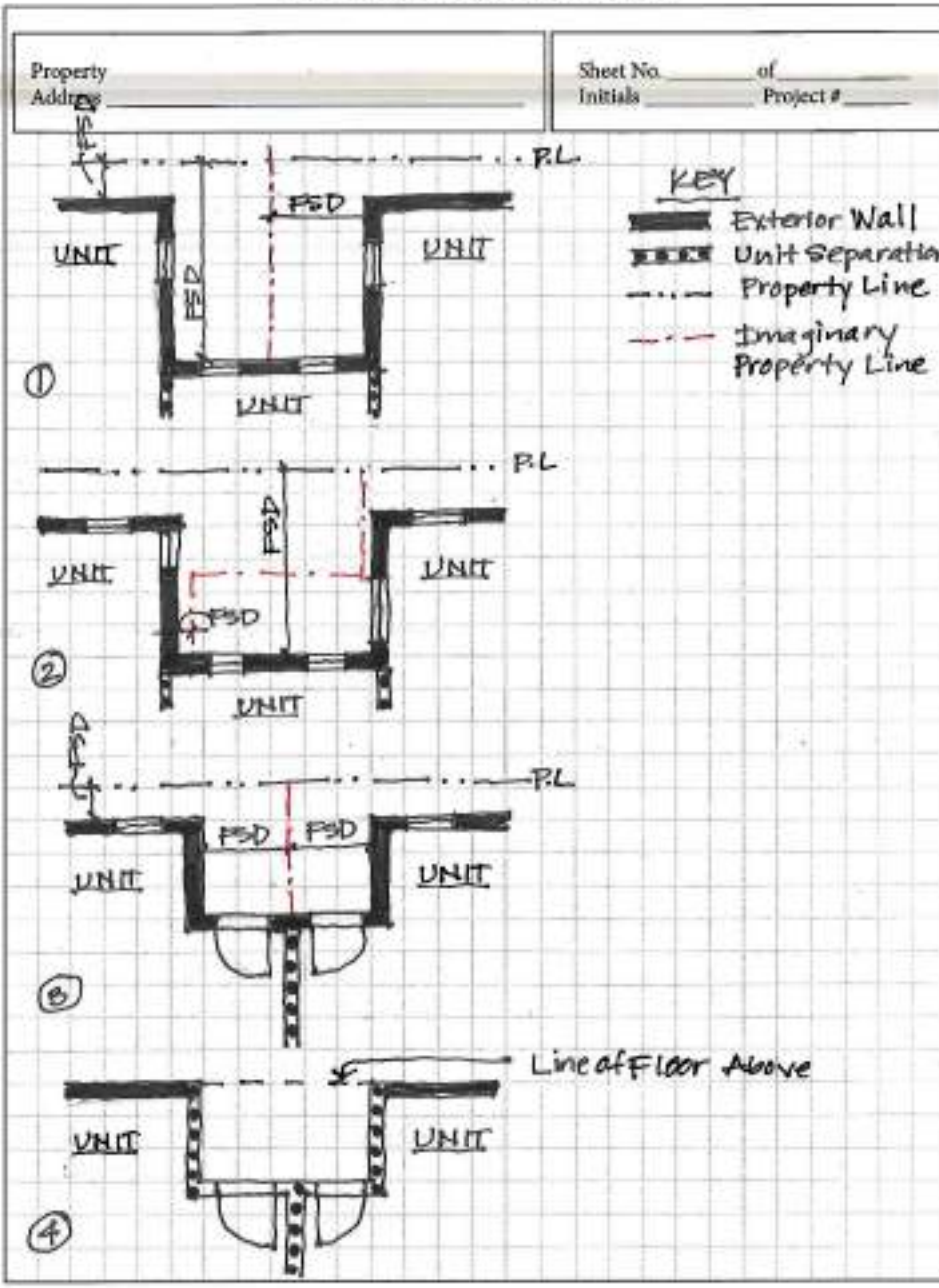

03.11

Plan Review Calculations DPD

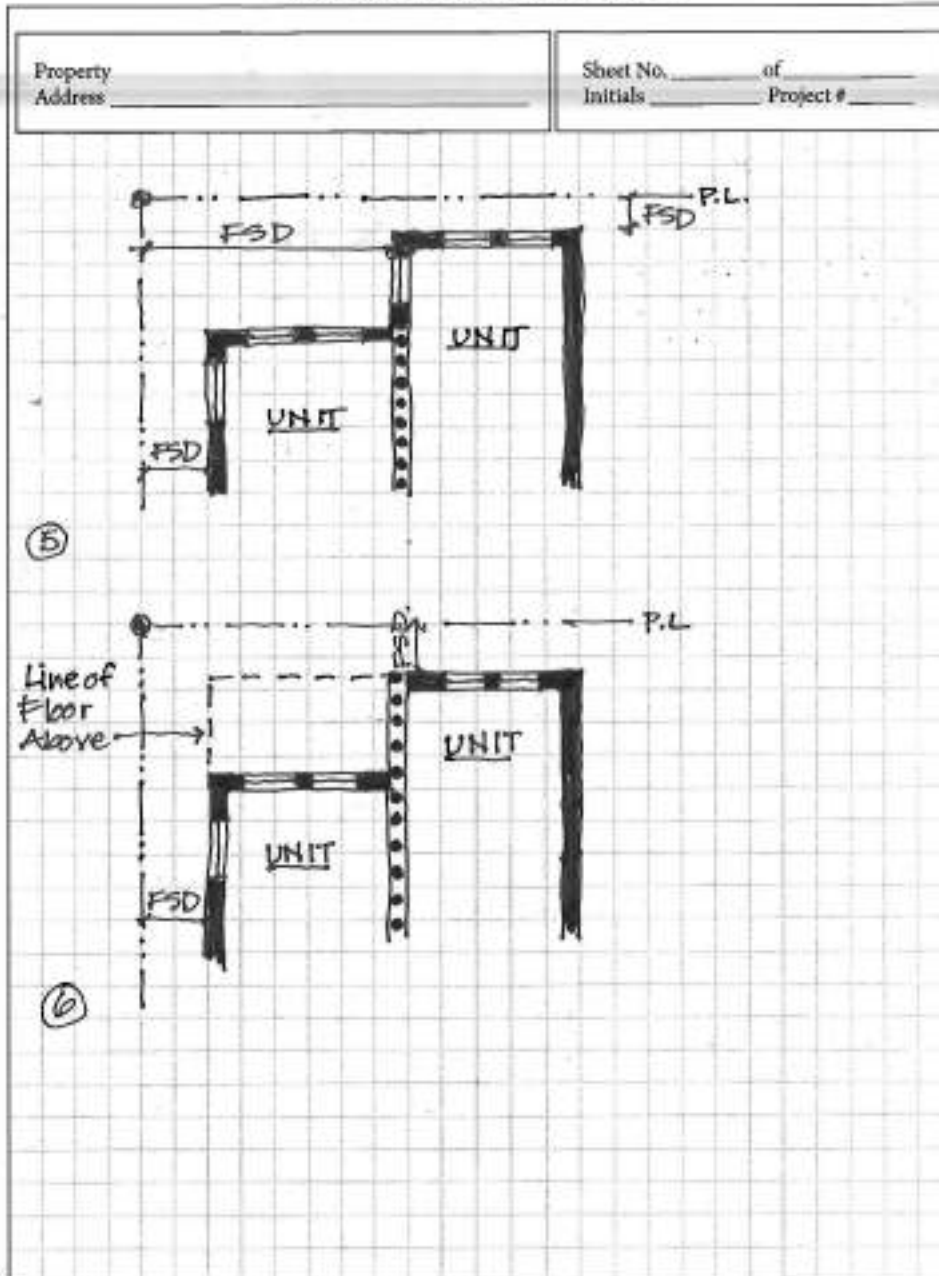

Cost Impact

The code change proposal will not increase or decrease the cost of construction .

Minimal cost implications for construction. Potential property damage and life savings as fires are more likely to be limited to the unit of origin.

Internal ID: 1658

G55-18

IBC: 420.8, 420.8.1, 420.9 (New);

IFC: 904.13 (IBC[F] 904.13)

Proponent: John Williams, Chair, representing Healthcare Committee (AHC@iccsafe.org)

2018 International Building Code

420.7 Group I-1 assisted living housing units. In Group I-1 occupancies, where a fire-resistance corridor is provided in areas where assisted living residents are housed, shared living spaces, group meeting or multipurpose therapeutic spaces open to the corridor shall be in accordance with all of the following criteria:

1. The walls and ceilings of the space are constructed as required for corridors.
2. The spaces are not occupied as resident sleeping rooms, treatment rooms, incidental uses in accordance with Section 509, or hazardous uses.
3. The open space is protected by an automatic fire detection system installed in accordance with Section 907.
4. In Group I-1, Condition 1, the corridors onto which the spaces open are protected by an automatic fire detection system installed in accordance with Section 907, or the spaces are equipped throughout with quick-response sprinklers in accordance with Section 903.3.2.
5. In Group I-1, Condition 2, the corridors onto which the spaces open, in the same smoke compartment, are protected by an automatic fire detection system installed in accordance with Section 907, or the *smoke compartment* in which the spaces are located is equipped throughout with quick-response sprinklers in accordance with Section 903.3.2.
6. The space is arranged so as not to obstruct access to the required *exits*.

Revise as follows:

420.8 Group I-1 cooking facilities. In Group I-1 occupancies, rooms or spaces that contain a cooking facilities facility with domestic cooking appliances shall ~~be in accordance with~~ be permitted to be open to the corridor where all of the following criteria are met:

1. In Group I-1, Condition 1 occupancies, the number of care recipients served by one cooking facility shall not be greater than 30.
2. In Group I-1, Condition 2 occupancies, the number of care recipients served by one cooking facility and within the same smoke compartment shall not be greater than 30.
- ~~3. The types of domestic cooking appliances permitted shall be limited to ovens, cooktops, ranges, warmers and microwaves.~~
- ~~4.3. The space containing the domestic cooking facilities shall be arranged so as not to obstruct access to the required exit.~~
- ~~5.4. Domestic cooking hoods installed and constructed in accordance with Section 505 of the International Mechanical Code shall be provided over cooktops or ranges. The cooking appliances shall comply with Section 420.9.~~
- ~~6. Cooktops and ranges shall be protected in accordance with Section 904.13.~~
- ~~7. A shutoff for the fuel and electrical supply to the cooking equipment shall be provided in a location that is accessible only to staff.~~
- ~~8. A timer shall be provided that automatically deactivates the cooking appliances within a period of not more than 120 minutes.~~
- ~~9. A portable fire extinguisher shall be provided. Installation shall be in accordance with Section 906 and the extinguisher shall be located within a 30 foot (9144 mm) distance of travel from each domestic cooking appliance.~~

Delete without substitution:

~~**420.8.1 Cooking facilities open to the corridor.** Cooking facilities located in a room or space open to a corridor, aisle or common space shall comply with Section 420.8.~~

420.9 Domestic cooking appliances. In Group I-1 occupancies, installation of cooking appliance used in domestic cooking facilities shall comply with all of the following:

1. The types of cooking appliances permitted shall be limited to ovens, cooktops, ranges, warmers and microwaves.
2. Domestic cooking hoods installed and constructed in accordance with Section 505 of the International Mechanical Code shall be provided over cooktops or ranges.
3. Cooktops and ranges shall be protected in accordance with Section 904.13.
4. A shutoff for the fuel and electrical supply to the cooking equipment shall be provided in a location that is accessible only to staff.
5. A timer shall be provided that automatically deactivates the cooking appliances within a period of not more than 120 minutes.
6. A portable fire extinguisher shall be provided. Installation shall be in accordance with Section 906 and the extinguisher shall be located within a 30-foot (9144 mm) distance of travel from each domestic cooking appliance.

2018 International Fire Code

Revise as follows:

904.13 Domestic cooking systems facilities. Cooktops and ranges installed in the following occupancies shall be protected in accordance with Section 904.13.1:

1. In Group I-1 occupancies where domestic cooking facilities are installed in accordance with Section ~~420.8~~ 420.9 of the International Building Code.
2. In Group I-2, Condition 1 occupancies where domestic cooking facilities are installed in accordance with Section 407.2.6 of the International Building Code.
3. In Group R-2 college dormitories where domestic cooking facilities are installed in accordance with Section 420.10 of the International Building Code.

Reason:

The intent of this proposal is for no technical change, but is to separate the requirements for domestic cooking appliances and exhaust from the allowance for that area to be open to the corridor in an assisted living facility. If someone wants to do a domestic cooking area in a room, such as for therapy or nutrition counseling purposes, they would still have to follow all the domestic cooking regulations for the equipment. This is also coordinated with the language for Group I-2, Condition 2 requirements in Section 407. This is not intended to change any of the provisions for the commercial cooking areas. The change in IFC is correlation only.

This proposal is submitted by the ICC Committee on Healthcare (CHC). The CHC was established by the ICC Board to evaluate and assess contemporary code issues relating to healthcare facilities. This is a joint effort between ICC and the American Society for Healthcare Engineering (ASHE), a subsidiary of the American Hospital Association, to eliminate duplication and conflicts in healthcare regulation. In 2017 the CHC held 2 open meetings and numerous conference calls, which included members of the committees as well as any interested parties, to discuss and debate the proposed changes. Information on the CHC, including: meeting agendas; minutes; reports; resource documents; presentations; and all other materials developed in conjunction with the CHC effort can be downloaded from the CHC website at: <https://www.iccsafe.org/codes-tech-support/cs/icc-committee-on-healthcare/>.

Cost Impact

The code change proposal will not increase or decrease the cost of construction .

This is an editorial separation with no technical changes for cooking facilities open to the corridor. This is a clarification of a domestic cooking appliance if it is within a room in a Group I-1 (assisted living). Currently some code officials would ask for commercial hoods, others would ask for domestic hoods.

Internal ID: 1296

G56-18

IBC: 420.8

Proponent: John Williams, Chair, representing Healthcare Committee (AHC@iccsafe.org)

2018 International Building Code

Revise as follows:

420.8 Group I-1 cooking facilities. In Group I-1 occupancies, rooms or spaces that contain cooking facilities with domestic cooking appliances shall be in accordance with all of the following criteria:

1. In Group I-1, Condition 1 occupancies, the number of care recipients served by one cooking facility shall not be greater than 30.
2. In Group I-1, Condition 2 occupancies, the number of care recipients served by one cooking facility and within the same smoke compartment shall not be greater than 30.
3. The types of domestic cooking appliances permitted shall be limited to ovens, cooktops, ranges, warmers and microwaves.
4. The space containing the domestic cooking facilities shall be arranged so as not to obstruct access to the required exit.
5. Domestic cooking hoods installed and constructed in accordance with Section 505 of the International Mechanical Code shall be provided over cooktops or ranges.
6. Cooktops and ranges shall be protected in accordance with Section 904.13.
7. A shutoff for the fuel and electrical supply to the cooking equipment shall be provided in a location that is accessible only to staff.
8. A timer shall be provided that automatically deactivates the cooking appliances within a period of not more than 120 minutes.
9. A portable fire extinguisher shall be provided. Installation shall be in accordance with Section 906 and the extinguisher shall be located within a 30-foot (9144 mm) distance of travel from each domestic cooking appliance.

Exceptions:

1. Cooking facilities provided within care recipient's individual dwelling units are not required to comply with this section.
2. Cooktops and ranges used for care recipient training or nutritional counseling are not required to comply with Item 6 of this section.

Reason:

If the proposal to split this section is also accepted, the exceptions would be applicable to the new section dealing with the cooktops and ranges.

This section was originally added to the code to allow assisted living facilities to have a more home like atmosphere, including small dining rooms and kitchen areas available to serve and possibly used by residents. The intent of this proposal is to allow for some exceptions for other domestic cooking.

Exception 1 - In Group I-1, Condition 1, sometimes there is limited cooking permitted within the units. In these limited situations additional protection, shut offs, timers and additional portable fire extinguishers are not justified.

Exception 2 - The idea of this proposal for kitchens in therapy areas or for nutrition counseling to not have to provide the UL300A hood protection features required to kitchens shared by care recipients.

This proposal is submitted by the ICC Committee on Healthcare (CHC). The CHC was established by the ICC Board to evaluate and assess contemporary code issues relating to healthcare facilities. This is a joint effort between ICC and the American Society for Healthcare Engineering (ASHE), a subsidiary of the American Hospital Association, to eliminate duplication and conflicts in healthcare regulation. In 2017 the CHC held 2 open meetings and numerous conference calls, which included members of the committees as well as any interested parties, to discuss and debate the proposed changes. Information on the CHC, including: meeting agendas; minutes; reports; resource documents; presentations; and all other materials developed in conjunction with the CHC effort can be downloaded from the CHC website at: <https://www.iccsafe.org/codes-tech-support/cs/icc-committee-on-healthcare/>.

Cost Impact

The code change proposal will not increase or decrease the cost of construction .

Cooktops and ranges used for domestic purposes would still have to comply with the IMC for ventilation. This is a clarification for where additional protection, shut offs, timers and additional portable fire extinguishers are not needed.

Internal ID: 1303

G57-18

IBC: 422.2

Proponent: Drew Dorrance, South Salt Lake City, representing South Salt Lake City (drd_007@hotmail.com)

2018 International Building Code

Revise as follows:

422.2 Separation. Ambulatory care facilities where the potential for four or more care recipients are to be incapable of self-preservation at any time shall be separated from adjacent spaces, corridors or tenants with a fire partition and a fire-rated horizontal assembly installed in accordance with ~~Section~~Sections 708 and 711.2

Reason:

Currently IBC section 422.2 addresses the vertical separation between ambulatory and non ambulatory care spaces. This section does not address a horizontal separation, when the same situation arises.

Cost Impact

The code change proposal will increase the cost of construction .

The cost for this change is directly impacted by the cost of a fire rated horizontal assembly, to include supporting construction.

Internal ID: 1471

G58-18

IBC: 422.1, 422.7 (New)

Proponent: John Williams, Chair, representing Healthcare Committee (AHC@iccsafe.org)

2018 International Building Code

Revise as follows:

422.1 General. Occupancies classified as *ambulatory care facilities* shall comply with the provisions of Sections 422.1 through ~~422.6~~422.7 and other applicable provisions of this code.

Add new text as follows:

422.7 Domestic cooking. Installation of cooking appliances used in domestic cooking facilities shall comply with all of the following:

1. The types of cooking appliances permitted are limited to ovens, cooktops, ranges, warmers and microwaves
2. Domestic cooking hoods installed and constructed in accordance with Section 505 of the International Mechanical Code shall be provided over cooktops or ranges.
3. A shutoff for the fuel and electrical supply to the cooking equipment shall be provided in a location that is accessible only to staff.
4. A timer shall be provided that automatically deactivates the cooking appliances within a period of not more than 120 minutes.
5. A portable fire extinguisher shall be provided. Installation shall be in accordance with Section 906 and the extinguisher shall be located within a 30-foot (9144 mm) distance of travel from each domestic cooking appliance.

Reason:

Physical therapy areas sometimes have kitchens to train patients in how to operate safely when they are cooking at home or as part of nutrition counseling. If a domestic cooking facility is set up in an ambulatory care facility for physical therapy or training, it should be treated the same as in Group I-1 and I-2 for similar areas.

This proposal is submitted by the ICC Committee on Healthcare (CHC). The CHC was established by the ICC Board to evaluate and assess contemporary code issues relating to healthcare facilities. This is a joint effort between ICC and the American Society for Healthcare Engineering (ASHE), a subsidiary of the American Hospital Association, to eliminate duplication and conflicts in healthcare regulation. In 2017 the CHC held 2 open meetings and numerous conference calls, which included members of the committees as well as any interested parties, to discuss and debate the proposed changes. Information on the CHC, including: meeting agendas; minutes; reports; resource documents; presentations; and all other materials developed in conjunction with the CHC effort can be downloaded from the CHC website at: <https://www.iccsafe.org/codes-tech-support/cs/icc-committee-on-healthcare/>.

Cost Impact

The code change proposal will increase the cost of construction .

Where someone wanted a cooking appliance for therapy or nutritional training, this would be an increase in requirements for the range and associated hood.

Internal ID: 1307

G59-18

IBC: 423.1, 423.2, 423.3 (New), 423.3.1 (New), 423.3.2 (New)

Proponent: Ed Kullik, Chair, representing ICC Building Code Action Committee (bcac@iccsafe.org)

2018 International Building Code

SECTION 423 STORM SHELTERS

Revise as follows:

423.1 General. This section applies to the construction of storm shelters constructed as separate detached buildings or constructed as rooms or spaces within buildings for the purpose of providing protection from storms that produce high winds, such as tornadoes and hurricanes during the storm. ~~Such structures shall be designated to be hurricane shelters, tornado shelters, or combined hurricane and tornado.~~ This section specifies where storm shelters are required and provides requirements for the design and construction of storm shelters. Design of facilities for use as emergency shelters after the storm are outside the scope of ICC 500 and shall comply with Table 1604.5 as a Risk Category IV Structure.

423.2 Construction. ~~In addition to other applicable requirements in this code, storm~~ Storm shelters shall be constructed in accordance with this code and ICC 500, and shall be designated as hurricane shelters, tornado shelters, or combined hurricane and tornado shelters. Buildings or structures that are also designated as emergency shelters shall also comply with Table 1604.5 as Risk Category IV structures. Any storm shelter not required by this section shall be permitted to be constructed provided such structures meet the requirements of this code and ICC 500.

Add new text as follows:

423.3 Occupancy classification. The occupancy classification for a storm shelter shall be determined in accordance with this section.

423.3.1 Dedicated storm shelters. A facility designed to be occupied solely as a storm shelter shall be classified as Group A-3 for the determination of requirements other than those covered in ICC 500.

Exceptions:

1. The occupancy category for dedicated storm shelters with an occupant load of less than 50 persons as determined in accordance with ICC 500 shall be in accordance with Section 303.
2. The occupancy category for a dedicated residential storm shelter shall be the Group R occupancy served.

423.3.2 Storm shelters within host buildings. Where designated storm shelters are constructed as a room or space within a host building which will normally be occupied for other purposes, the requirements of this code for the occupancy of the building, or the individual rooms or spaces thereof, shall apply unless otherwise required by ICC 500.

Reason:

ICC 500 contains specific requirements for determining the occupancy classification of storm shelters, whether constructed as a standalone building or as a room or space inside a host building which will normally be occupied for other purposes (e.g. a multi-purpose room in a Group E school or a conference room in a Group B office building). This code change adapts the occupancy language from ICC 500 and adds it to Section 423 where it will be directly accessible to all code users.

Occupancy classifications for storm shelters are broken down into four categories:

Dedicated storm shelters: Large community storm shelters may house hundreds of occupants. Thus, the ICC 500 committee deemed it appropriate to classify these shelters as Assembly Group A-3.

Small dedicated storm shelters: Some community shelters may only serve a small number of occupants. The ICC 500 committee deemed it appropriate to permit these smaller shelters to be classified as Group B as allowed by IBC Section 303.1.1

Shelters in a host building: Storm shelters constructed within a larger building as a room or space which will be used for other purposes under normal conditions (e.g. a multi-purpose room in a Group E school or a conference room in a Group B office building) are permitted to be classified using the occupancy category applicable to the space as it is normally used.

Residential storm shelters. Currently under ICC 500 these would be classified as Group B since they are limited to a maximum of 16 occupants, thus could use the Section 303.1.1 allowance. It is more appropriate that they be classified as Group R since that is the occupancy to which they are an accessory structure.

In addition, Sections 423.1 (General) and 423.2 (Construction) are revised to provide better scoping and charging language for storm shelters. The General paragraph is amended to highlight that Section 423 contains language requiring the installation of storm shelters in critical facilities such as fire stations, ambulance stations, and emergency operations centers (existing Section 423.3) and in Group E occupancies (existing Section 423.4). The requirement to classify storm shelters as hurricane, tornado, or both is relocated to the Construction provision, and a new paragraph is added to clarify that a storm shelter may be constructed in, or accessory to, any other buildings or structures governed by the IBC, where they would not otherwise be required, as long as the shelter complies with the appropriate requirements of the IBC and ICC 500. This is similar to language that exists in Section 901.2 for fire protection systems.

This proposal is submitted by the ICC Building Code Action Committee (BCAC). BCAC was established by the ICC Board of Directors in July 2011 to pursue opportunities to improve and enhance assigned International Codes or portions thereof. In 2017 the BCAC has held 3 open meetings. In addition, there were numerous Working Group meetings and conference calls for the current code development cycle, which included members of the committee as well as any interested party to discuss and debate the proposed changes. Related documentation and reports are posted on the BCAC website at: <https://www.iccsafe.org/codes-tech-support/codes/code-development-process/building-code-action-committee-bcac>.

Cost Impact

The code change proposal will not increase or decrease the cost of construction .

This proposal clarifies the occupancy classifications of storm shelters by adding the requirements from ICC 500 to Section 423.

Internal ID: 2261

G60-18

IBC: 423.3, 423.4, 423.4.1, 423.4.2

Proponent: Benchmark Harris, representing self (bharris@huckabee-inc.com)

2018 International Building Code

Revise as follows:

423.3 Critical emergency operations. In areas where the shelter design wind speed for tornados in accordance with Figure 304.2(1) of ICC 500 is 250 mph, 911 call stations, emergency operation centers and fire, rescue, ambulance and police stations shall comply with Table 1604.5 as a Risk Category IV structure and shall be provided with a tornado storm shelter constructed in accordance with ICC 500.

423.4 Group E occupancies. In areas where the shelter design wind speed for tornados is 250 mph in accordance with Figure 304.2(1) of ICC 500, all Group E occupancies with an occupant load of 50 or more shall have a tornado storm shelter constructed in accordance with ICC 500.

Exceptions:

1. Group E day care facilities.
2. Group E occupancies accessory to places of religious worship.
3. Buildings meeting the requirements for tornado storm shelter design in ICC 500.

423.4.1 Required occupant capacity. The required occupant capacity of the tornado storm shelter shall include all of the buildings on the site and shall be the greater of the following:

1. The total occupant load of the classrooms, vocational rooms and offices in the Group E occupancy.
2. The occupant load of any indoor assembly space that is associated with the Group E occupancy.

Exceptions:

1. Where a new building is being added on an existing Group E site, and where the new building is not of sufficient size to accommodate the required occupant capacity of the storm shelter for all of the buildings on the site, the storm shelter shall at a minimum accommodate the required occupant capacity for the new building.
2. Where approved by the code official, the required occupant capacity of the shelter shall be permitted to be reduced by the occupant capacity of any existing tornado storm shelters on the site.

423.4.2 Location. Storm shelters shall be located within the buildings they serve or shall be located where the maximum distance of travel from not fewer than one exterior door of each building to a door of the tornado storm shelter serving that building does not exceed 1,000 feet (305 m).

Reason:

A storm shelter can be a tornado shelter, hurricane shelter or both. The design wind speed and debris impact criteria are less for hurricane shelters than for tornado shelters with a design wind speed of 250 mph. The intent of this provision is to require tornado storm shelters, not hurricane storm shelters.

For example, Guam is located in a region in which the design wind speed is 250 mph but they are also in a hurricane prone region where the design wind speed for hurricane shelters is less than 250 mph. This proposed change clarifies that it is not acceptable for a location like Guam to simply construct a hurricane storm shelter for E occupancy buildings with greater than 50 occupants; it is required to construct either a tornado storm shelter or a combined tornado and hurricane storm shelter.

Substantiation to support proposed change:

The following is an excerpt from “**Chapter 2: Definitions**” of THE 2018 IBC:

STORM SHELTER. A building, structure or portions thereof, constructed in accordance with ICC 500 and designated for use during a severe wind storm event, such as a hurricane or tornado.

Community storm shelter. A storm shelter not defined as a “Residential storm shelter.”

Residential storm shelter. A storm shelter servicing occupants of dwelling units and having an occupant load not exceeding 16 persons.

Cost Impact

The code change proposal will not increase or decrease the cost of construction .

This proposal is to clarify the original code intent.

Internal ID: 2163

G61-18

IBC: 423.4

Proponent: Benchmark Harris, representing Self (bharris@huckabee-inc.com)

2018 International Building Code

Revise as follows:

423.4 Group E occupancies. In areas where the shelter design wind speed for tornados is 250 mph in accordance with Figure 304.2(1) of ICC 500, all Group E occupancies with an occupant load of 50 or more shall have a storm shelter constructed in accordance with ICC 500.

Exceptions:

1. Group E day care facilities that do not function as a school in which attendance by children is required by state law.
2. Group E occupancies accessory to places of religious worship.
3. Buildings meeting the requirements for shelter design in ICC 500.

Reason:

The purpose of the exception is to allow construction of a “day care” without a storm shelter. Day cares provide care to pre-school age children while parents are working and often provide care for Elementary or Middle School students before or after regular school hours. The intent of this exception is to not require tornado shelters for the children that are not required by state law to attend a public school or an equivalent education program. State Laws in all 50 States require attendance by children at a public school or equivalent educational program. Where children are in a day care at the choice of their parents or guardians, the parents or guardians have direct control over whether or not it is acceptable for their children to be in a facility without a tornado shelter.

However, because the IBC does not establish a maximum age limit on day care students, one could misinterpret the language in the 2018 IBC to allow considering an Elementary school as a day care so as to avoid requiring a tornado shelter.

Substantiation to support proposed change:

The following is Section 305 of the 2018 IBC. Section 305.2 does not establish a maximum age limit on day care students.

“SECTION 305

EDUCATIONAL GROUP E

305.1 Educational Group E.

Educational Group E occupancy includes, among others, the use of a building or structure, or a portion thereof, by six or more persons at any one time for educational purposes through the 12th grade.

305.1.1 Accessory to places of religious worship.

Religious educational rooms and religious auditoriums, which are accessory to places of religious worship in accordance with Section 303.1.4 and have occupant loads of less than 100 per room or space, shall be classified as Group A-3 occupancies.

Section 305.2 Group E, day care facilities.

This group includes buildings and structures or portions thereof occupied by more than five children older than 2 ½ years of age who receive educational, supervision or personal care services for fewer than 24 hours per day.

305.2.1 Within places of religious worship.

Rooms and spaces within places of religious worship providing such day care during religious functions shall be classified as part of the primary occupancy.

305.2.2 Five or fewer children.

A facility having five or fewer children receiving such day care shall be classified as part of the primary occupancy.

305.2.3 Five or fewer children in a dwelling unit.

A facility such as the above within a dwelling unit and having five or fewer children receiving such day care shall be classified as a Group R-3 occupancy or shall comply with the International Residential Code.”

Also, attached is a report on Compulsory School Age Requirements by the Education Commission of the States, which shows that all 50 States have minimum mandatory ages, which vary from State to State, generally from 5 to 8 years old but more commonly either 6 or 7 years old. This information was obtained for free online at

<http://www.ncsl.org/documents/educ/ECSCompulsoryAge.pdf> This link was established January 8, 2018

Cost Impact

The code change proposal will not increase or decrease the cost of construction .

This proposal clarifies original code intent.

Internal ID: 2167

G62-18

IBC: 423.4

Proponent: Benchmark Harris, representing Self (bharris@huckabee-inc.com)

2018 International Building Code

Revise as follows:

423.4 Group E occupancies. In areas where the shelter design wind speed for tornados is 250 mph in accordance with Figure 304.2(1) of ICC 500, all Group E occupancies with an occupant load of 50 or more shall have a storm shelter constructed in accordance with ICC 500.

Exceptions:

1. Group E day care facilities.
2. ~~Group E occupancies~~ Religious educational rooms and religious auditoriums, which are accessory to places of religious worship.
3. Buildings meeting the requirements for shelter design in ICC 500.

Reason:

The phrase “religious educational rooms and religious auditoriums, which are accessory to places of religious worship” the appropriate phrase to identify building areas with a primarily religious function which should not be required to have shelters. The original language, on the other hand, could be incorrectly interpreted to waive the requirements for shelters in any private school as long as they simply have a religious affiliation. This incorrect interpretation would be discriminatory as it would not permit a waiver for private schools that do not have a religious affiliation.

Substantiation to support proposed change:

The following is Section 305 of the 2018 IBC. Section 305.1.1 uses the phrase “religious educational rooms and religious auditoriums, which are accessory to places of religious worship” (similar to the language used in Section 303.1.4).

“SECTION 305

EDUCATIONAL GROUP E

305.1 Educational Group E. Educational Group E occupancy includes, among others, the use of a building or structure, or a portion thereof, by six or more persons at any one time for educational purposes through the 12th grade.

305.1.1 Accessory to places of religious worship. Religious educational rooms and religious auditoriums, which are accessory to places of religious worship in accordance with Section 303.1.4 and have occupant loads of less than 100 per room or space, shall be classified as Group A-3 occupancies.

Section 305.2 Group E, day care facilities. This group includes buildings and structures or portions thereof occupied by more than five children older than 2 ½ years of age who receive educational, supervision or personal care services for fewer than 24 hours per day.

305.2.1 Within places of religious worship. Rooms and spaces within places of religious worship providing such day care during religious functions shall be classified as part of the primary occupancy.

305.2.2 Five or fewer children. A facility having five or fewer children receiving such day care shall be classified as part of the primary occupancy.

305.2.3 Five or fewer children in a dwelling unit. A facility such as the above within a dwelling unit and having five or fewer children receiving such day care shall be classified as a Group R-3 occupancy or shall comply with the International Residential Code.”

Cost Impact

The code change proposal will not increase or decrease the cost of construction .

This proposal is simply clarifying the original code intent.

Internal ID: 2212

G63-18

IBC: 423.4.1

Proponent: Daniel Dain, representing Self (daniel.dain@stantec.com)

2018 International Building Code

Revise as follows:

423.4.1 Required occupant capacity. The required occupant capacity of the storm shelter shall include all of the ~~buildings~~ Group E occupancies on the site and shall be the greater of the following:

1. The total occupant ~~load~~ capacity of the classrooms, vocational rooms and offices in the Group E occupancy.
2. The occupant ~~load~~ capacity of any indoor assembly space that is associated with the Group E occupancy.

Exceptions:

1. Where a new building is being added on an existing Group E site, and where the new building is not of sufficient size to accommodate the required occupant capacity of the storm shelter for all of the buildings on the site, the storm shelter shall at a minimum accommodate the required occupant capacity for the new building.
2. Where approved by the code official, the required occupant capacity of the shelter shall be permitted to be reduced by the occupant capacity of any existing storm shelters on the site.

Reason:

Below is the explanation for what IBC says regarding determining the **“Occupant Capacity”** for storm shelter. The suggestion would be to define this and use in lieu of “Occupant Load” because AHJ’s are having trouble distinguishing the difference. Code and fire officials are hung up on Chapter 10 Egress “occupant load” calculations for determining required shelter capacity.

2015 IBC

2015 IBC requires a storm shelter for E occupancies per Section 423. The section does not indicate or reference how to determine the occupant load. It does not reference anything in regards to egress, i.e. Chapter 10 or table 1004. Identifying the number of building occupants on a typical average school day has nothing to do with egress, it's not about fire exiting. It's about how much sf do we need to fit the building occupants. Section 1004.1 Design Occupant Load states “In determining means of egress requirements, the number of occupants for whom means of egress facilities are provided shall be determined in accordance with this section.”

The commentary in Section 423 states “Once the number of occupants to be accommodated is decided, ICC 500 provides details for the design and construction of the shelter”. It continues to state “It is not the intent to require the shelter to be designed for the total occupant load of the building that is used for means of egress. Where there is a situation where the classrooms would be empty if the gymnasium was full, such as an all-school assembly, or after-hours sporting event, the storm shelter can be designed to accommodate that occupant load.”

You will not find any reference in IBC 423, ICC 500, or FEMA P-361 to Chapter 10 of the IBC, it does not exist, that was never the intent. Keep in mind up until the 2015 IBC storm shelters were not required by occupancy type. If we designed a storm shelter at a rec center we would work with the owner to determine an appropriate capacity. For example, we may only have 5,000sf of usable space at $5/sf = 1,000$ occupants.

2018 IBC

Refer to text of EB 68-15, Dave Bowman ICC email, and 2015 IBC Storm Shelters AMENDED (which was issued by City of McKinney, TX).

The explanation of the ADDED Provisions states “Worse case occupant load is used for all spaces for fire exiting, but total occupant load for the building is excessive for storm shelter design. The determination for the required capacity of the shelter is based on the number of staff and students that will be in the school during a typical school day or any indoor assembly space that would be fully utilized outside school hours, whichever is greater. Thus, rather than the total occupant load of the building, the capacity of the shelter is appropriately based on occupant load described in the two scenarios described in Item 1 and 2.”

School districts may rely on enrollment data, fore Texas TEA capacity limits, and any other data or documentation they determine to identify the number of staff and students that will be in the school during a typical school day.

423.4.1 Required occupant capacity. The required occupant capacity of the storm shelter shall include all the buildings on the site, and shall be the greater of the following:

1. The total occupant load of the classrooms, vocational rooms and offices in the Group E occupancy.
2. The occupant load of any indoor assembly space that is associated with the Group E occupancy.

ICC 500

Chapter 5 of the ICC 500 requires 5 sf per person. A 35% reduction on top of that is significant to consider furniture, walls, etc and our calculation still gives us more sf than we need (xx sf required vs xx sf usable). Reversing the calculation we have enough sf after the reductions to hold xx people (divide usable sf by 5). Keep in mind they will put as many people as they can safely fit and the requirement is only for 2 hours. The redundancy and worst case is built into the calculations.

ICC 500 should be updated also:

202 Definitions

Storm Shelter Occupant Load Capacity. The occupant load capacity intended for a room or space when that space is in use as a storm shelter.

[https://www.dropbox.com/scl/fo/35k4h0ub1654e3oeq8x61/AAAVLyk4PiU0DBo7qxP0ch8ca?](https://www.dropbox.com/scl/fo/35k4h0ub1654e3oeq8x61/AAAVLyk4PiU0DBo7qxP0ch8ca?dl=0&oref=e&r=AAmvqDhg6vcJDcl69Qfy36u-1vU-Z8CArzb_b_fyfwMcCMrbW8uKG4QhxkkMltn9aiOhtf4DptukbvurSm-WwOYjkE6PKtAZO1VwTwO7KfSKMte8N2T7GvbL95D1NW2p7JrqMqf8YeirjZmbx3fj_zsMSP75ugwL5RZLB6VTUWkUtL2IQqKFEpgHKAuE&sm=1)

[dl=0&oref=e&r=AAmvqDhg6vcJDcl69Qfy36u-1vU-Z8CArzb_b_fyfwMcCMrbW8uKG4QhxkkMltn9aiOhtf4DptukbvurSm-WwOYjkE6PKtAZO1VwTwO7KfSKMte8N2T7GvbL95D1NW2p7JrqMqf8YeirjZmbx3fj_zsMSP75ugwL5RZLB6VTUWkUtL2IQqKFEpgHKAuE&sm=1](https://www.dropbox.com/scl/fo/35k4h0ub1654e3oeq8x61/AAAVLyk4PiU0DBo7qxP0ch8ca?dl=0&oref=e&r=AAmvqDhg6vcJDcl69Qfy36u-1vU-Z8CArzb_b_fyfwMcCMrbW8uKG4QhxkkMltn9aiOhtf4DptukbvurSm-WwOYjkE6PKtAZO1VwTwO7KfSKMte8N2T7GvbL95D1NW2p7JrqMqf8YeirjZmbx3fj_zsMSP75ugwL5RZLB6VTUWkUtL2IQqKFEpgHKAuE&sm=1)

Link established 2.19.18

Cost Impact

The code change proposal will decrease the cost of construction .

The intent of this language is to clarify the commentary from the 2018 code proposed language that the intent when determining the occupant "capacity" of the storm shelter is not to use the building occupant "load" used for egress, which would result in shelters being over sized and higher construction costs.

Internal ID: 446

G64-18

IBC: 423.4.1

Proponent: Benchmark Harris, representing National Storm Shelter Association (bharris@huckabee-inc.com)

2018 International Building Code

Revise as follows:

423.4.1 Required occupant capacity. The required occupant capacity of the storm shelter shall include all of the buildings on the site and shall be the ~~greater of the following:~~

1. The total occupant load of the classrooms, vocational rooms and offices in the Group E occupancy.
2. ~~The occupant load of any indoor assembly space that is associated with the Group E occupancy.~~

Exceptions:

1. Where a new building is being added on an existing Group E site, and where the new building is not of sufficient size to accommodate the required occupant capacity of the storm shelter for all of the buildings on the site, the storm shelter shall at a minimum accommodate the required occupant capacity for the new building.
2. Where approved by the code official, the required occupant capacity of the shelter shall be permitted to be reduced by the occupant capacity of any existing storm shelters on the site.

Reason:

During normal daily use, there should not be more than the regular population of the school. If there is an assembly with more people than are regularly in the school, then adults have chosen to create that event and those adults have the ability to gauge the safety of venturing out and assembling. It should not be necessary to size the tornado shelter for indoor assembly events.

Cost Impact

The code change proposal will not increase or decrease the cost of construction .

This proposed code change simply clarifies the intent of the original code language.

Internal ID: 2124

G65-18

IBC: 423.4.1

Proponent: Benchmark Harris, representing self (bharris@huckabee-inc.com)

2018 International Building Code

Revise as follows:

423.4.1 Required occupant capacity. The required occupant capacity of the storm shelter shall include all of the buildings on the site and shall be the greater of the following:

1. The total occupant load of the classrooms, vocational rooms and offices in the Group E occupancy.
2. The occupant load of ~~any~~ the largest indoor assembly space that is associated with the Group E occupancy.

Exceptions:

1. Where a new building is being added on an existing Group E site, and where the new building is not of sufficient size to accommodate the required occupant capacity of the storm shelter for all of the buildings on the site, the storm shelter shall at a minimum accommodate the required occupant capacity for the new building.
2. Where approved by the code official, the required occupant capacity of the shelter shall be permitted to be reduced by the occupant capacity of any existing storm shelters on the site.

Reason:

The original language could be misinterpreted to indicate that item 2 of 423.4.1 refers to the occupant load of the sum of any indoor assembly spaces, whereas this provision should only require shelters accommodate the largest indoor assembly space because it is extremely unlikely that all indoor assembly spaces would be occupied to the maximum permitted fire egress limit and a significant tornado would strike the building.

Cost Impact

The code change proposal will not increase or decrease the cost of construction .

This proposal simply clarifies the code intent.

Internal ID: 2255

G66-18

IBC: 402.6.3, 424.1, 424.2, 424.3, 424.4, 424.5, 424.5.1 (New), [F] TABLE 903.2.11.6 IFC TABLE 903.2.11.6

Proponent: Ed Kullik, representing ICC Building Code Action Committee (bcac@iccsafe.org)

2018 International Building Code

Revise as follows:

402.6.3 Children's play-Play structures. ~~Children's play-Play~~ structures located within the ~~mall~~ of a ~~covered mall~~ building or within the perimeter line of an *open mall building* shall comply with Section 424. The horizontal separation between ~~children's~~ play structures, kiosks and similar structures within the *mall* shall be not less than 20 feet (6096 mm).

SECTION 424 CHILDREN'S PLAY STRUCTURES

424.1 General. ~~Children's play-Play~~ structures installed inside all occupancies covered by this code that exceed 10 feet (3048 mm) in height or 150 square feet (14 m²) in area shall comply with Sections 424.2 through 424.5.

424.2 Materials. ~~Children's play-Play~~ structures shall be constructed of noncombustible materials or of combustible materials that comply with the following:

1. *Fire-retardant-treated* wood complying with Section 2303.2.
2. Light-transmitting plastics complying with Section 2606.
3. Foam plastics (including the pipe foam used in soft-contained play equipment structures) having a maximum heat-release rate not greater than 100 kilowatts when tested in accordance with UL 1975 or when tested in accordance with NFPA 289, using the 20 kW ignition source.
4. Aluminum composite material (ACM) meeting the requirements of Class A *interior finish* in accordance with Chapter 8 when tested as an assembly in the maximum thickness intended for use.
5. Textiles and films complying with the fire propagation performance criteria contained in Test Method 1 or Test Method 2, as appropriate, of NFPA 701.
6. Plastic materials used to construct rigid components of soft-contained play equipment structures (such as tubes, windows, panels, junction boxes, pipes, slides and decks) exhibiting a peak rate of heat release not exceeding 400 kW/ m² when tested in accordance with ASTM E1354 at an incident heat flux of 50 kW/m² in the horizontal orientation at a thickness of 6 mm.
7. Ball pool balls, used in soft-contained play equipment structures, having a maximum heat-release rate not greater than 100 kilowatts when tested in accordance with UL 1975 or when tested in accordance with NFPA 289, using the 20 kW ignition source. The minimum specimen test size shall be 36 inches by 36 inches (914 mm by 914 mm) by an average of 21 inches (533 mm) deep, and the balls shall be held in a box constructed of galvanized steel poultry netting wire mesh.
8. Foam plastics shall be covered by a fabric, coating or film meeting the fire propagation performance criteria contained in Test Method 1 or Test Method 2, as appropriate, of NFPA 701.
9. The floor covering placed under the children's play structure shall exhibit a Class I interior floor finish classification, as described in Section 804, when tested in accordance with ASTM E648 or NFPA 253.
10. Interior finishes for structures exceeding 300 square feet (28 m²) in area or 10 feet (3048 mm) in height shall have a flame spread index not greater than that specified in Table 803.13 for the occupancy group and location designated. Interior wall and ceiling finish materials tested in accordance with NFPA 286 and meeting the acceptance criteria of Section 803.1.1.1, shall be permitted to be used where a Class A classification in accordance with ASTM E84 or UL 723 is required.

[F] 424.3 Fire protection. ~~Children's play-Play~~ structures shall be provided with the same level of *approved* fire suppression and detection devices required for other structures in the same occupancy.

424.4 Separation. ~~Children's play-Play~~ structures shall have a horizontal separation from building walls, partitions and from elements of the *means of egress* of not less than 5 feet (1524 mm). Children's playground structures shall have a horizontal separation from other children's play structures of not less than 20 feet (6090 mm).

424.5 Area limits. ~~Children's play~~ Play structures shall be not greater than 300 square feet (28 m²) in area, unless a special investigation, acceptable to the building official, has demonstrated adequate fire safety.

Add new text as follows:

424.5.1 Design. Play structures exceeding 300 square feet (28 m²) in area or 10 feet (3048 mm) in height shall be designed in accordance with Section 1601.1.

Revise as follows:

**[F] TABLE 903.2.11.6
ADDITIONAL REQUIRED SUPPRESSION SYSTEMS**

SECTION	SUBJECT
402.5, 402.6.2	Covered and open mall buildings
403.3	High-rise buildings
404.3	Atriums
405.3	Underground structures
407.6	Group I-2
410.7	Stages
411.4	Special amusement buildings
412.3.6	Airport traffic control towers
412.4.6, 412.4.6.1, 412.6.5	Aircraft hangars
415.11.11	Group H-5 HPM exhaust ducts
416.5	Flammable finishes
417.4	Drying rooms
419.5	<i>Live/work units</i>
424.3	Children's Play structures
427	Buildings containing laboratory suites
507	Unlimited area buildings
509.4	Incidental uses
1029.6.2.3	Smoke-protected assembly seating
IFC	Sprinkler system requirements as set forth in Section 903.2.11.6 of the International Fire Code

Reason:

Indoor play structures can cover a wide range of activities and are not limited to children’s play structures. Some examples of these are; indoor skydiving, permanent haunted houses, very large and tall rock climbing walls in gymnasiums of schools and universities, laser tag facilities with elevated and large structures having massive concealed spaces, Indoor archery ranges with foam 3d targets and any number of other indoor activities with recreational structures located within a building. A growing number of “I” Occupancy structures are now adding adult playgrounds. A climbing or skydiving facility may be well over 1000 sf in area/footprint and I have recently reviewed one over 42’ in height. The structure in many cases needs to be designed per IBC Chapter 16 and ASCE 7, in a seismic zone it may be considered a “nonbuilding structure or attachment” with special design considerations needed. There are often unique structural stability and anchorage requirements, plus many potential fire safety issues dealing with concealed spaces and flame spread requirements. I think this change will not clutter the section nor create confusion as 424.1 already calls out “Children’s Play Structures installed inside all occupancies. I have not altered the term “Children’s” in section 424.4 as I believe that is a very unique requirement applicable to children’s playground equipment and would not apply to other larger play structures where they meet the design and FLS requirements for finishes and fire protection by submitting a special Investigation to the building Official as noted in section 424.5.

This proposal is submitted by the ICC Building Code Action Committee (BCAC). BCAC was established by the ICC Board of Directors in July 2011 to pursue opportunities to improve and enhance assigned International Codes or portions thereof. In 2017 the BCAC has held 3 open meetings. In addition, there were numerous Working Group meetings and conference calls for the current code development cycle, which included members of the committee as well as any interested party to discuss and debate the proposed changes. Related documentation and reports are posted on the BCAC website at: <https://www.iccsafe.org/codes-tech-support/codes/code-development-process/building-code-action-committee-bcac>.

Cost Impact

The code change proposal will increase the cost of construction .

This proposal is primarily a revision that clarifies that play structures are not necessarily just used by children. The requirements apply regardless of this designation. I one were to interpret the code as meaning that this is an expansion of requirements, then this could be taken to be that the cost of construction is increased. Since the requirements for larger play structures is expanded somewhat, the cost of construction may increase.

G67-18

IBC: [F] 424.3

Proponent: Jeffrey Hugo, representing National Fire Sprinkler Association (hugo@nfsa.org)

THIS CODE CHANGE WILL BE HEARD BY THE FIRE CODE COMMITTEE. SEE THE TENTATIVE HEARING ORDER FOR THIS COMMITTEE

2018 International Building Code

[F] 424.3 Fire protection. Children's play structures shall be provided with ~~the same level of approved fire suppression and detection devices~~ fire protection systems required for other structures in the same occupancy.

Reason:

The term suppression is used in several ways throughout the IFC. Suppression is not a defined term, but it means to extinguish the fire or is commonly used as a fire department response term. The IFC uses suppression in ways that are not related to fire extinguishment or fire department response. This proposal adjusts lists, and charging sections to hone in to the intent of the section and replaces with a more exclusive and defined term of fire protection system. A fire protection system is a sprinkler system, an alarm system, a standpipe system and on and on. It is a better term. This proposal is consistent with an FCAC proposal that revises this terminology throughout the IFC and IBC in Chapter 9 and other locations.

Cost Impact

The code change proposal will decrease the cost of construction .

Using defined terms in the code will save on mis-interpretation and mis-application of the code.

Internal ID: 1863

G68-18

IBC: 424.5

Proponent: Marcelo Hirschler, GBH International, representing GBH International (gbhint@aol.com)

2018 International Building Code

Revise as follows:

424.5 Area limits. Children's play structures complying with Section 424.2 shall be not greater than ~~300~~600 square feet (~~28~~56 m²) in area, unless a special investigation, acceptable to the building official, has demonstrated adequate fire safety.

Reason:

The requirements contained in sections 424.2 are sufficiently adequate for fire safety that it is unnecessary to limit the area to which they apply simply to the range of 150 square feet up to 300 square feet. Note that, also, there is a requirement, in 424.3, for including active fire protection in the compartment where the structure is installed (not in the children's play structure itself).

Cost Impact

The code change proposal will decrease the cost of construction .

This code proposal will make it unnecessary to conduct a fire hazard assessment for children play structures that are between 300 and 600 square feet in area, if they meet the requirements of 424.2.

Internal ID: 1028

G69-18

IBC: [F]426.1

Proponent: Ellie Klausbruckner, Klausbruckner & Associates Inc., representing Klausbruckner & Associates, Inc. (ek@klausbruckner.com)

THIS CODE CHANGE WILL BE HEARD BY THE FIRE CODE COMMITTEE. SEE THE TENTATIVE HEARING ORDER FOR THIS COMMITTEE

2018 International Building Code

Revise as follows:

[F] 426.1 General. The provisions of Sections 426.1.1 through 426.1.7 shall apply to buildings in which materials that produce combustible dusts are stored or handled. Buildings that store or handle combustible dusts shall comply with the applicable provisions of the International Fire Code. Where required by the fire code official, NFPA 652 and the applicable provisions of NFPA 61, NFPA 85, NFPA 120, NFPA 484, NFPA 654, NFPA 655 and NFPA 664 ~~and the International Fire Code shall apply.~~

Reason:

A complete revision of Chapter 22 of the IFC has been proposed. The chapter is intended to address many of the issues that concern fire departments (sources of ignition, duct collection, housekeeping, etc). NFPA 652 is a very useful standard and has been referenced in the new chapter should the fire code official require additional analysis. However it is no longer the only option for compliance. Therefore the language is revised to allow for the fire code official to require this analysis for more complicated uses and facilities, without the need to require it for every single facility that has or produces combustible dust.

Cost Impact

The code change proposal will decrease the cost of construction .

The proposed code change will decrease the cost for complicated analysis during plan submittals and inspections phase of a construction project.

Internal ID: 1618

G70-18

IBC: [F]426.1, [F]426.1.1, [F]426.1.2, [F]426.1.3, [F]426.1.4, [F]426.1.5, [F]426.1.6, [F]426.1.7

Proponent: Robert Davidson, Davidson Code Concepts, LLC, representing Self (rjd@davidsoncodeconcepts.com)

THIS CODE CHANGE WILL BE HEARD BY THE FIRE CODE COMMITTEE. SEE THE TENTATIVE HEARING ORDER FOR THIS COMMITTEE

2018 International Building Code

SECTION [F] 426 COMBUSTIBLE DUSTS, COMBUSTIBLE FIBERS, GRAIN PROCESSING AND STORAGE

Revise as follows:

[F] 426.1 General. ~~The provisions of Sections 426.1.1 through 426.1.7 shall apply to buildings in which materials that produce combustible dusts are stored or handled.~~ Buildings that store or handle combustible dusts or combustible fibers shall comply with NFPA 652 and the applicable provisions of NFPA 61, NFPA 85, NFPA 120, NFPA 484, NFPA 654, NFPA 655 and NFPA 664 and the International Fire Code. The provisions of Sections 426.2 through 426.8 shall apply as appropriate to buildings in which materials that produce combustible dusts are stored or handled.

[F] 426.1.1-426.2 Type of construction and height exceptions. Buildings shall be constructed in compliance with the height, number of stories and area limitations specified in Sections 504 and 506; except that where erected of Type I or II construction, the heights and areas of grain elevators and similar structures shall be unlimited, and where of Type IV construction, the maximum building height shall be 65 feet (19 812 mm) and except further that, in isolated areas, the maximum building height of Type IV structures shall be increased to 85 feet (25 908 mm).

[F] 426.1.2-426.3 Grinding rooms. Every room or space occupied for grinding or other operations that produce combustible dusts in such a manner that the ~~room or space is classified as a Group H-2 occupancy concentration and conditions create a fire or explosion hazard based a dust hazard analysis prepared in accordance with Section 426.1 and NEPA 652~~ shall be enclosed with fire barriers constructed in accordance with Section 707 or horizontal assemblies constructed in accordance with Section 711, or both. The fire-resistance rating of the enclosure shall be not less than 2 hours where the area is not more than 3,000 square feet (279 m²), and not less than 4 hours where the area is greater than 3,000 square feet (279 m²).

[F] 426.1.3-426.4 Conveyors. Conveyors, chutes, piping and similar equipment passing through the enclosures of rooms or spaces shall be constructed dirt tight and vapor tight, and be of *approved* noncombustible materials complying with Chapter 30.

[F] 426.1.4-426.5 Explosion control. Explosion control shall be provided as specified in the International Fire Code, ~~or spaces shall be equipped with the equivalent mechanical ventilation complying with the International Mechanical Code.~~

[F] 426.1.5-426.6 Grain elevators. Separation distance. Grain elevators, malt houses and buildings for ~~similar occupancies other operations that produce combustible dusts in such a manner that the concentration and conditions create a fire or explosion hazard based on a dust hazard analysis prepared in accordance with Section 426.1 and NFPA 652~~ shall not be located within 30 feet (9144 mm) of interior *lot lines* or structures on the same *lot*, except where erected along a railroad right-of-way.

[F] 426.1.6-426.7 Coal pockets. Coal pockets located less than 30 feet (9144 mm) from interior lot lines or from structures on the same lot shall be constructed of not less than Type IB construction. Where more than 30 feet (9144 mm) from interior *lot lines*, or where erected along a railroad right-of-way, the minimum type of construction of such structures not more than 65 feet (19 812 mm) in *building height* shall be Type IV.

[F] 426.1.7-426.8 Tire rebuilding. Buffing operations shall be located in a room separated from the remainder of the building housing the tire rebuilding or tire recapping operation by a 1-hour *fire barrier*.

Exception: Buffing operations are not required to be separated where all of the following conditions are met:

1. Buffing operations are equipped with an *approved* continuous automatic water-spray system directed at the point of cutting action.
2. Buffing machines are connected to particle-collecting systems providing a minimum air movement of 1,500 cubic feet per minute (cfm) (0.71 m³/s) in volume and 4,500 feet per minute

(fpm) (23 m/s) in-line velocity.

3. The collecting system shall discharge the rubber particles to an *approved* outdoor noncombustible or fire-resistant container, which is emptied at frequent intervals to prevent overflow.

Reason:

This proposal is follow up work correlating the IBC and IFC provisions with the work done on Chapter 22 Combustible Dust and Chapter 37 Combustible Fibers in the IFC along with Section 426 of the IBC. Last cycle IBC Section 426 and IFC Chapter 22 were updated to incorporate NFPA 652 Standard on the Fundamentals of Combustible Dust.

An editorial change has been made with the numbering of the subsections. They are not a running subsection to 426.1, each covers a topic that an occupancy with a combustible dust hazard might have to comply with. The numbering scheme is a holdover from when the requirements were buried within another portion of the code.

The section title is modified to add "Combustible Fibers". A key hazard of combustible fibers can be combustible dust. The addition will highlight the need to apply this section to designers and code officials.

Section 426.1 is modified by switching the order of the sentences and adding "combustible fibers". This is to ensure this section and the dust hazard analysis in NFPA 652 is applied across the board to combustible dust and combustible fiber occupancies.

Section 426.1.2 (New 426.3) is modified to replace the Group H-2 trigger with one that refers to conditions that create a fire or explosion hazard based upon a dust hazard analysis.

Section 426.1.4 (New 426.5) is modified by eliminating the explosion control alternative reference to the IMC. Ventilation can be a form of explosion control, but the correct path is through Section 911 of the IFC and its referenced standard NFPA 69.

Section 426.1.5 (New 426.6) has been re-titled to "Separation distance" to correctly identify the subject matter and in place of similar occupancies which is subjective the wording "other operations that produce combustible dusts in such a manner that the concentration and conditions create a fire or explosion hazard based on a Dust Hazard Analysis prepared in accordance with Section 426.1 and NFPA 652" has been inserted.

Cost Impact

The code change proposal will not increase or decrease the cost of construction .

The intent of these changes is not to change the cost of construction, simply to clean up and correlate language to other changes in the codes. Any time correlation is improved the cost of construction can be reduced.

Internal ID: 1619

G71-18 Part I

Part I: IBC: 202 (New), 802.8 (New), 429 (New), 429.1 (New), 429.2 (New), 429.3 (New), 429.4 (New), 429.5 (New), 429.6 (New), 429.7 (New), 429.8 (New); IFC: 202 (New), 801.2 (New), 802.1

Part II: IFC: 202 (New), 801.2 (New), 802.1

Proponent: Homer Maiel, representing ICC Tri-Chapter (Peninsula, East Bay, Monterey Bay) (hmaiel@gmail.com)

THIS IS A 2 PART CODE CHANGE PROPOSAL. PART I WILL BE HEARD BY THE GENERAL CODE DEVELOPMENT COMMITTEE. PART II WILL BE HEARD BY THE FIRE CODE COMMITTEE. SEE THE TENTATIVE HEARING ORDERS FOR THESE COMMITTEES.

2018 International Building Code

SECTION 202 DEFINITIONS

Add new definition as follows:

INDOOR HORTICULTURAL GROW STRUCTURE. An enclosed structure installed within buildings that creates a controlled environment for enhanced horticultural growing conditions utilizing an artificial light source.

Add new text as follows:

429 INDOOR HORTICULTURAL GROW STRUCTURES

429.1 General. Indoor horticultural grow structures installed and operated inside all occupancies covered by this code that exceed 5 feet (1524mm) in height and 32 square feet (3.0 m²) in floor area shall comply with Sections 429.2 through 429.8.

429.2 Materials.

Horticultural grow structures shall be constructed of noncombustible materials or of combustible materials that comply with the following:

1. Textiles and films complying with Test Method 2 of NFPA 701.
2. Foam plastics having a maximum heat-release rate not greater than 100 kilowatts when tested in accordance with UL 1975 or when tested in accordance with NFPA 289, using the 20 kW ignition source.
3. Solid plastic materials used to construct rigid components exhibiting a peak rate of heat release not exceeding 400 kW/ m² when tested in accordance with ASTM E1354 at an incident heat flux, of 50 kW/m²; in the horizontal orientation at a thickness of 6 mm.
4. Fire-retardant-treated wood complying with Section 2303.2.
5. Light-transmitting plastics complying with Section 2606.
6. Aluminum composite material (ACM) meeting the requirements meeting the requirements of Class A interior finish in accordance with Chapter 8 when tested as an assembly in the maximum thickness intended for use.

429.3 Electrical wiring and equipment. Electrical wiring, luminaires and equipment shall be listed and labeled for the intended use and installed in accordance with the manufacturer's instructions and NFPA 70.

429.4 Carbon dioxide enrichment systems. Where provided, carbon dioxide enrichment systems shall comply with Section 5307.4 of the International Fire Code.

429.5 Heating appliances. Where heating appliances are installed, these devices shall be installed in accordance with the manufacturer's instructions and the requirements found in Chapter 9 of the International Mechanical Code.

429.6 Fire protection systems. All required fire protection systems shall be in accordance with section 901.2 of this Code. Clearance shall be maintained between automatic sprinklers and the top of horticultural grow structures in accordance with NFPA 13.

429.7 Clearance from ignition sources. Clearance between indoor horticultural grow structures and ignition sources such as luminaires, heaters and grow lamps shall be maintained in an approved manner.

429.8 Area limits. Indoor horticultural grow structures shall not exceed an aggregate 200 square feet (18.6 m²) of floor area per fire area, unless a special investigation, acceptable to the code official, has demonstrated adequate fire safety.

802.8 Indoor horticultural grow structures. The materials used to construct indoor horticultural grow structures shall comply with Section 429.

Internal ID: 1053

G71-18 Part II

IFC: SECTION 202, 202 (New), 801.2 (New), 802.1

Proponent: Homer Maiel, representing ICC Tri-Chapter (Peninsula, East Bay, Monterey Bay) (hmaiel@gmail.com)

2018 International Fire Code

SECTION 202 GENERAL DEFINITIONS

Add new definition as follows:

INDOOR HORTICULTURAL GROW STRUCTURE An enclosed structure installed within buildings that creates a controlled environment for enhanced horticultural growing conditions utilizing an artificial light source.

Add new text as follows:

801.2 Indoor horticultural grow structures. The materials used to construct horticultural grow structures in new and existing buildings shall comply with Section 429 of the International Building Code.

802.1 Definitions. INDOOR HORTICULTURAL GROW STRUCTURE.

Reason:

The definition of an Indoor Horticultural Grow Structure includes the use of an artificial light source to help differentiate it from a greenhouse operation which utilizes a sunlit environment.

Horticultural grow structures constructed of combustible materials are increasingly being used indoors in commercial and residential occupancies, and sizes vary from 2 ft. by 2 ft. to over 10 ft. by 20 ft. Examples of these products and related accessories can be found at:

[https://www.amazon.com/s/ref=sr_st_price-desc-rank?](https://www.amazon.com/s/ref=sr_st_price-desc-rank?keywords=Indoor+Grow+Tents&rh=i%3Aaps%2Ck%3AIndoor+Grow+Tents&qid=1514996452&sort=price-desc-rank)

[keywords=Indoor+Grow+Tents&rh=i%3Aaps%2Ck%3AIndoor+Grow+Tents&qid=1514996452&sort=price-desc-rank](https://www.amazon.com/s/ref=sr_st_price-desc-rank?keywords=Indoor+Grow+Tents&rh=i%3Aaps%2Ck%3AIndoor+Grow+Tents&qid=1514996452&sort=price-desc-rank)

There are several safety concerns that need to be addressed to ensure adequate safety is provided, which are addressed in the proposal and described as follows. The proposed requirements are similar to those included in IBC Section 424 for indoor children's play structures. Specific comments on the proposal include the following:

IFC Section 801.2 - The reference to IBC Section 429 is provided as a convenience to the user, and to clarify that the requirements apply to installations in new and existing buildings.

IBC Section 802.7 - This reference is provided for users who are looking for fabric and material flammability requirements for these structures.

Section 429.1 - Threshold size limitations are proposed to exclude smaller horticultural grow structures that represent less of a fire hazard compared to larger structures.

Section 429.2 - Requirements are similar to those in Section 424.2.

Section 429.4 - Carbon dioxide enrichment systems are sometimes sold as accessories for horticultural grow structures. A reference is provided to the IFC requirements covering these systems as a convenience to the code user.

Section 429.8 - The area limit concept is similar to that in Section 424, and allows the code official to address fire hazards with larger areas without having to invoke imminent hazard or hazard abatement requirements in the code.

Cost Impact

The code change proposal will increase the cost of construction .

This action will increase the cost of construction. There may be an additional cost of materials used to comply with Section 429.2, and to comply with the additional safety requirements.

Internal ID: 3509

G72-18

IBC: 202, 308.1.1(New), 429 (New), Chapter 35

Proponent: Dave Frable, U.S. General Services Administration, representing U.S. General Services Administration

2018 International Building Code

SECTION 202 DEFINITIONS

Add new definition as follows:

LOCK-UP An area located within a building or structure having a predominant occupancy classification other than Group I-3, and where the occupants for penal or correctional purposes are detained for less than 24 hours by the use of security measures not under the occupants' control.

Add new text as follows:

308.1.1 Lock-ups. Lock-ups located within a building or structure having a predominant occupancy classification other than Group I-3, where the area has capacity for not more than 50 detainees, and where no individual is detained for 24 hours or more, shall comply with the requirements of the predominant occupancy of the building or structure in which the lock-up is located and with the requirements of Section 429. Lock-ups having a capacity for more than 50 detainees or where any individual is detained for 24 hours or more shall be classified as Group I-3 occupancy and shall comply with the other applicable requirements in this code.

429 LOCK-UPS

429.1 General. Lock-ups located within a building or structure having a predominant occupancy classification other than Group I-3, where the area has capacity for not more than 50 detainees, and where no individual is detained for 24 hours or more, shall comply with the provisions in Sections 429.1 through 429.5 and other applicable provisions of this code.

429.2 Automatic Sprinkler System. Buildings and structures where lock-ups are located shall be equipped throughout with an automatic sprinkler system in accordance with Section 903.3.1.1.

429.3 Fire Alarm System. Buildings and structures where lock-ups are located shall be equipped with a fire alarm system that initiates the occupant notification signal installed in accordance with Section 907.6.

429.4 Lock-up Criteria. The lock-up shall comply with the requirements for the predominant occupancy of the building in which the lockup is located, and the following criteria:

1. Doors and other physical restraints to free egress by detainees can be readily released by staff within 2-minutes of the onset of a fire or similar emergency.
2. Staff is in sufficient proximity to the lock-up so as to be able to cause the 2-minute release required by Item1 whenever detainees occupy the lockup.

Exception:Where staff is not in sufficient proximity to the lock-up so as to be able to cause the 2-minute release required by Item 2, an automatic smoke detection system shall be installed throughout the lock-up area installed in accordance with the requirements in NFPA 72.
3. Staff is authorized to cause the release required by Item 1.
4. Staff is trained and practiced in effecting the release required by Item1.
5. Where the release required by Item1 is caused by means of remote release, detainees are not to be restrained from evacuating without the assistance of others.
6. Where security operations necessitate the locking of required means of egress, the following shall apply:
 - 6.1. Detention-grade hardware complying with ASTM F 1577 shall be provided on swinging doors within the required means of egress.
 - 6.2. Sliding doors within the required means of egress shall be designed and engineered for detention and correctional use, and lock cylinders shall meet the cylinder test requirements of ASTM F 1577.

429.5 Fire department notification. The building owner/manager shall notify the fire department with responsibility to respond to the building or structure of the presence of the lockup.

Add new standard(s) follows:

ASTM

ASTM International
100 Barr Harbor Drive, P.O. Box
C700
West Conshohocken PA 19428-
2959
US

F1577-05 (2012):

Standard Test Methods for Detention locks for Swinging Doors

Analysis: A review of the standard proposed for inclusion in the code, [INSERT STANDARD], with regard to the ICC criteria for referenced standards (Section 3.6 of CP#28) will be posted on the ICC website on or before April 2, 2018.

Reason:

The intent of this code change proposal is to address the subject matter of ‘lock-ups” where the occupants for penal or correctional purposes are detained for less than 24 hours by the use of security measures not under the occupants’ control. A lock-up is basically a holding area in which persons are detained with some degree of security imposed on them that are commonly located in different types of occupancies. For example, lockups are typically located in U.S. Customs and Border Protection facilities at border crossings, airports and seaports; prisoner holding facilities at courthouses; local police departments; security offices at sports stadia; security offices at shopping mall complexes; etc. Currently, the requirements within the IBC require “lock-ups” to meet the rigorous defend in place requirements applicable to Institutional Group I-3 occupancies. This code change proposal provides requirements specifically for lock-ups located in building and structures having a predominant occupancy classification other than Institutional Group I-3 occupancy and provides a reasonable set of safe guards applicable to the predominant occupancy of the building in which the lock-up is located. The subject provisions for lock-ups are meant to apply to holding areas having a capacity of not more than 50 detainees, in which no individual is detained for 24 hours or more. The threshold for the holding area to limit the capacity to not more than 50 detainees is based on the requirements in NFPA 101, Life Safety Code, and seems reasonable for processing/holding areas for facilities at border crossings, airports and seaports and prisoner holding facilities at courthouses.

Section 202 has been revised to include a new definition for a lock-up. Section 308 has also been revised to include a new sub-section 308.1 on lock-ups

A new Section 429, Lock-Ups has been created to provide a reasonable set of safe guards applicable for when a predominant occupancy of the building or structure has an occupancy classification other than Institutional Group I-3 occupancy in which the lock-up is located. For example, safe guards include, but are not limited to: an automatic sprinkler system throughout the building or structure, a fire alarm system, a 2-minute timeframe for trained staff to release the detainees or an option for the installation of a smoke detection system within the lock-up area if the 2-minute timeframe for trained staff to release the detainees cannot be met, detention-grade door hardware to improve reliability, and building owner/manager notification of the local responding fire department of the presence of the lock-up.

Please note that the subject code change proposal is based on the requirements for lock-ups in the National Fire Protection Association 101, Life Safety Code (2018 edition).

The intent of this proposal is to reference ASTM Standard F 1577-05 (2012), Standard Test Methods for Detention Locks for Swinging Doors to improve the reliability of detention-grade hardware for lock-ups.

Cost Impact

The code change proposal will not increase or decrease the cost of construction .

We believe the subject code change proposal to include lock-ups will not affect the cost of construction either way.

Requiring lock cylinders of detention door hardware to meet the cylinder test requirements of ASTM F 1577 may increase construction costs.

Analysis: A review of the standard proposed for inclusion in the code, ASTM F1577-05 (2012), with regard to the ICC criteria for referenced standards (Section 3.6 of CP#28) will be posted on the ICC website on or before April 2, 2018.

G73-18

IBC 503.1.4

Proponent: Lee Kranz, City of Bellevue, WA, representing Washington Association of Building Officials Technical Code Development Committee (lkranz@bellevuewa.gov)

2018 International Building Code

Revise as follows:

503.1.4 Occupied roofs. A roof level or portion thereof shall be permitted to be used as an occupied roof provided the occupancy of the roof is an occupancy that is permitted by Table 504.4 for the story immediately below the roof. The area of the occupied roofs shall not be included in the *building area* as regulated by Section 506.

Exceptions:

1. The occupancy located on an occupied roof shall not be limited to the occupancies allowed on the *story* immediately below the roof where the building is equipped throughout with an *automatic sprinkler system* in accordance with Section 903.3.1.1 or 903.3.1.2 and occupant notification ~~in accordance with Section 907.5~~ where required by Section 907.2 is provided in the area of the occupied roof.
2. Assembly occupancies shall be permitted on roofs of open parking spaces of Type I or Type II construction, in accordance with the exception to Section 903.2.1.6.

503.1.4.1 Enclosures over occupied roof areas. Elements or structures enclosing the occupied roof areas shall not extend more than 48 inches (1220 mm) above the surface of the occupied roof.

Exception: Penthouses constructed in accordance with Section 1510.2 and towers, domes, spires and cupolas constructed in accordance with Section 1510.5.

Reason:

This code change is needed to clarify exactly what is required for exception #1 of Section 503.1.4 in terms of providing occupant notification in the area of the occupied roof. This is done by replacing the reference to 907.5 with 907.2 which provides scoping for fire alarms based on the occupancy served on the occupied roof. Section 907.5 is referenced from 907.2 so once the scope of the fire alarm system is determined in 907.2 designers will then go to 907.5 to determine installation requirements.

Cost Impact

The code change proposal will not increase or decrease the cost of construction .

This is simply a clarification of the requirements. There will be no cost impact.

Internal ID: 85

G74-18

IBC: 503.1.4.1

Proponent: Jay Hyde, representing Sacramento Valley Association of Building Officials (jhyde@mogaveroarchitects.com)

2018 International Building Code

Revise as follows:

503.1.4.1 Enclosures surrounding occupied roof areas. Elements or structures enclosing occupied roof areas shall not extend more than 48 inches (1220 mm) above the surface of the occupied roof.

~~Exception~~**Exceptions:**

1. Penthouses constructed in accordance with Section 1510.2 and towers, domes, spires and cupolas constructed in accordance with Section 1510.5.
2. Exterior walls or fire walls of adjacent buildings in conformance with the following:
 - 2.1. The exterior sides of the occupied roof not surrounded by adjacent buildings, penthouses, towers, domes spires and cupolas shall have uniformly distributed parapets with a sill height not greater than 48 inches (1220 mm).
 - 2.2. The aggregate length of the parapets shall not be less than 40 percent of the total exterior wall.
 - 2.2.1. Parapets are not required to be distributed over 40 percent of the occupied roof perimeter where they are uniformly distributed over two opposing sides of the occupied roof.

Reason:

Buildings with occupied roofs may be located between two adjacent buildings restricting openness, access and ventilation. This proposal considers that the open side/ventilation requirements for open parking garages contained in IBC Section 406.5.2 will provide the necessary openness and ventilation for occupied roofs.

Cost Impact

The code change proposal will not increase or decrease the cost of construction .

This code change proposal will not increase or decrease the cost of construction because this exception is permissive, not mandatory: it permits a designer to locate an occupied roof on a building which is not freestanding.

Internal ID: 1417

G75-18

IBC: TABLE 504.3

Proponent: Stephen DiGiovanni, representing ICC Ad Hoc Committee on Tall Wood Buildings (TWB) (TWB@iccsafe.org)

2018 International Building Code

Revise as follows:

**TABLE 504.3
ALLOWABLE BUILDING HEIGHT IN FEET ABOVE GRADE PLANE^a**

OCCUPANCY CLASSIFICATION	TYPE OF CONSTRUCTION											TYPE OF CONSTRUCTION	TYPE OF CONSTRUCTION
	SEE FOOTNOTES	TYPE I		TYPE II		TYPE III		TYPE IV				TYPE V	
		A	B	A	B	A	B	A	B	C	HT	A	B
A, B, E, F, M, S, U	NS ^b	UL	160	65	55	65	55	<u>65</u>	<u>65</u>	<u>65</u>	65	50	40
	S	UL	180	85	75	85	75	<u>270</u>	<u>180</u>	<u>85</u>	85	70	60
H-1, H-2, H-3, H-5	NS ^{c, d}	UL	160	65	55	65	55	<u>120</u>	<u>90</u>	<u>65</u>	65	50	40
	S												
H-4	NS ^{c, d}	UL	160	65	55	65	55	<u>65</u>	<u>65</u>	<u>65</u>	65	50	40
	S	UL	180	85	75	85	75	<u>140</u>	<u>100</u>	<u>85</u>	85	70	60
I-1 Condition 1, I-3	NS ^{d, e}	UL	160	65	55	65	55	<u>65</u>	<u>65</u>	<u>65</u>	65	50	40
	S	UL	180	85	75	85	75	<u>180</u>	<u>120</u>	<u>85</u>	85	70	60
I-1 Condition 2, I-2	NS ^{d, e, f}	UL	160	65	55	65	55	<u>65</u>	<u>65</u>	<u>65</u>	65	50	40
	S	UL	180	85									
I-4	NS ^{d, g}	UL	160	65	55	65	55	<u>65</u>	<u>65</u>	<u>65</u>	65	50	40
	S	UL	180	85	75	85	75	<u>270</u>	<u>180</u>	<u>85</u>	85	70	60
R ^h	NS ^d	UL	160	65	55	65	55	<u>65</u>	<u>65</u>	<u>65</u>	65	50	40
	S13D	60	60	60	60	60	60	<u>60</u>	<u>60</u>	<u>60</u>	60	50	40
	S13R	60	60	60	60	60	60	<u>60</u>	<u>60</u>	<u>60</u>	60	60	60
	S	UL	180	85	75	85	75	<u>270</u>	<u>180</u>	<u>85</u>	85	70	60

For SI: 1 foot = 304.8 mm.

UL = Unlimited; NS = Buildings not equipped throughout with an automatic sprinkler system; S = Buildings equipped throughout with an automatic sprinkler system installed in accordance with Section 903.3.1.1; S13R = Buildings equipped throughout with an automatic sprinkler system installed in accordance with Section 903.3.1.2; S13D = Buildings equipped throughout with an automatic sprinkler system installed in accordance with Section 903.3.1.3.

- a. See Chapters 4 and 5 for specific exceptions to the allowable height in this chapter.
- b. See Section 903.2 for the minimum thresholds for protection by an automatic sprinkler system for specific occupancies.
- c. New Group H occupancies are required to be protected by an automatic sprinkler system in accordance with Section 903.2.5.
- d. The NS value is only for use in evaluation of existing building height in accordance with the International Existing Building Code.
- e. New Group I-1 and I-3 occupancies are required to be protected by an automatic sprinkler system in accordance with Section 903.2.6. For new Group I-1 occupancies Condition 1, see Exception 1 of Section 903.2.6.
- f. New and existing Group I-2 occupancies are required to be protected by an automatic sprinkler system in accordance with Section 903.2.6 and Section 1103.5 of the *International Fire Code*.
- g. For new Group I-4 occupancies, see Exceptions 2 and 3 of Section 903.2.6.
- h. New Group R occupancies are required to be protected by an automatic sprinkler system in accordance with Section 903.2.8.

Reason:

The Ad Hoc Committee on Tall Wood Buildings (TWB) was created by the ICC Board to explore the science of tall wood buildings and take action on developing code changes for tall wood buildings. The TWB has created several code change proposals with respect to the concept of tall buildings of mass timber and the background information is at the end of this Statement. Within the statement are important links to information, including documents and videos, used in the deliberations which resulted in these proposals.

The TWB and its various WGs held meetings, studied issues and sought input from various expert sources around the world. The TWB has posted those documents and input on its website for interested parties to follow its progress and to allow those parties to, in turn, provide input to the TWB.

At its first meeting, the TWB discussed a number of performance objectives to be met with the proposed criteria for tall wood buildings:

No collapse under reasonable scenarios of complete burn-out of fuel without automatic sprinkler protection being considered.

No unusually high radiation exposure from the subject building to adjoining properties to present a risk of ignition under reasonably severe fire scenarios.

No unusual response from typical radiation exposure from adjacent properties to present a risk of ignition of the subject building under reasonably severe fire scenarios.

No unusual fire department access issues.

Egress systems designed to protect building occupants during the design escape time, plus a factor of safety.

Highly reliable fire suppression systems to reduce the risk of failure during reasonably expected fire scenarios. The degree of reliability should be proportional to evacuation time (height) and the risk of collapse.

The comprehensive package of proposals from the TWB meet these performance objectives. The TWB also determined that fire testing was necessary to validate these concepts. At its first meeting, members discussed the nature and intention of fire testing so as to ensure meaningful results for the TWB and, more specifically, for the fire service. Subsequently a test plan was developed. The fire tests consisted of one-bedroom apartments on two levels, with both apartments having a corridor leading to a stair. The purpose of the tests was to address the contribution of mass timber to a fire, the performance of connections, the performance of joints, and to evaluate conditions for responding fire personnel. The Fire WG then refined the test plan, which was implemented with a series of five, full-scale, multiple-story building tests at the Alcohol, Tobacco and Firearms (ATF) laboratories in Beltsville, MD. The results of those tests, as well as testing conducted by others, helped form the basis upon which the Codes WG developed its code change proposals. This code change proposal is one of those developed by the Codes WG and approved by the TWB.

To review a summary of the fire tests, please visit:

<http://bit.ly/ATF-firetestreport>

To watch summary videos of the fire tests, which are accelerated to run in 3-1/2 minutes each, please visit:

<http://bit.ly/ATF-firetestvideos>.

Both of these links were confirmed active on 12/27/17

Allowable Height

This proposal addresses the allowable building height, in terms of feet, for the three new construction types proposed by the TWB. As set forth in the proposal to Section 602.4, the three new types of construction are Types IV-A, IV-B, and IV-C. The Committee examined each proposed type of construction for its safety and efficacy with regard to each occupancy type.

The following approach was used to develop proposed allowable heights of the new construction types, based on the conclusions of the Committee:

Based upon TWB review of fire safety and structural integrity performance, Type IV-B is equated to Type I-B for height (in feet). A noteworthy item to remember is that, per Section 403.2.1.1 of the IBC, Type IB construction is permitted to be reduced to 1-hour Fire Resistance rating; however, the TWB does not propose to allow the same reduction for Type IV-B. As a result, the comparison is between 2-hr mass timber construction that is partially exposed, versus 1-hr Type IB construction, and the Committee believes that 2-hr mass timber construction that is partially exposed per the limits of proposed Section 602.4 warrants the same heights as allowed for 1-hr Type I-B construction. It should be noted that the unprotected mass timber also needs to meet the 2 hour FRR, thus the protected area will likely be conservatively higher FRR than actually required;

Type IV-A should be somewhat larger than IV-B, as Type IV-A construction is entirely protected (no exposed mass timber permitted) and the required rating of the structure is equivalent to those required of Type I-A construction (3-hr rating for structural frame). However, the Committee did not find it acceptable to allow the unlimited heights of Type I-A to be applied to Type IV-A. Instead, the Committee applied a multiplier of 1.5 to the heights proposed for Type IV-B construction, in order to propose reasonable height allowances for IV-A construction;

The Committee viewed Type IV-C as similar to existing HT construction with the exception that IV-C has a 2 hour FRR where HT is acceptably fire resistant based on the large sizes of the members. As such, the height in feet is proposed to be equal to the height in feet of Type IV-HT. In terms of stories, however, the Committee proposed an additional number of stories for IV-C in recognition of its greater FRR.

4. While the base code seems to allow significant heights for buildings without sprinklers (e.g., Table 504.3 currently allows a height of 160 feet for NS Type I-B construction for many occupancy classifications), the Committee believes that no additional heights over what is already permitted for Type IV-HT would be proposed for the NS (non sprinklered) rows. As such, where separate rows are provided for heights for the NS situation, the proposed heights for Types IV-A, IV-B, and IV-C are the same as those heights already permitted for Type IV for the NS condition.

This methodology explains the majority of the recommendations here. Specifically, for occupancy groups A, B, E, F, I-4, M, R, S, U, the methodology described above accurately reflects how the height proposals were developed.

After undergoing this methodology to develop initial height recommendations, the Committee then applied professional judgment (from both a fire safety and a structural perspective), to develop a working draft table, cell by cell, for all occupancy types.

The exercise for establishing the allowable number of stories for the three new types of construction started with setting Type I-B allowances equivalent to Type IV-B. The tabular fire resistance ratings of building elements for these two types of construction is identical (not including the reduction permitted by 403.2.1.1), so the identical number of stories was deemed a reasonable starting point. From this point, the TWB Committee reviewed each occupancy classification to see if the Type I-B story allowance required adjustment.

Following is a summary of how allowable number of stories for sprinklered I-B were adjusted for IV-B:

A-1, A-2, A-3, A-4, A-5, B, E, H-1, H-5, I-1(1), I-1(2), I-2, I-3, I-4, R-1, R-2, R-3, R-4, U: no adjustment, same number of allowable stories as Type I-B.

F-1 and S-1: reduced from 12 to 7 (2 story increase from Type IV-HT)

F-2, M, S-2: reduced from 12 to 8 (2 story increase from Type IV-HT)

H-2: reduced from 3 to 2 (same as Type IV-HT)

H-3: reduced from 6 to 4 (same as IV-Type HT)

H-4: reduced from 8 to 7 (1 story increase from Type IV-HT)

Similarly, to establish the height in feet for Type IV-B:

A-1, A-2, A-3, A-4, A-5, B, E, F-1, F-2, I-4, M, R-1, R-2, R-3, R-4, S-1, S-2, U: same allowable height as I-B.

H-1, H-2, H-3: reduced from 180' to 90'

H-4: reduced from 180' to 100'

H-5: reduced from 160' to 90'

I-1(1): reduced from 180' to 120'

I-1(2): reduced from 180' to 65'

I-2: reduced from 180' to 65'

I-3: reduced from 180' to 120'

Adjusting IV-B up to IV-A for allowable number of stories:

A-1, A-2, A-3, A-4, A-5, B, E, F-2, I-4, M, R-1, R-2, R-3, R-4, S-1, S-2, U - 1.5 x IV-B number of stories

F-1, S-1 increase by 3 stories

H-1, H-3 same as IV-HT

H-2, H-4, H-5 increase by 1 story

I-1(1), I-1(2), I-2, I-3 increase by 2 stories

H-3 reduced from 6 to 4 (same as IV-HT)

H-4 reduced from 8 to 7 (1 story increase from IV-HT)

I-1(1), I-1(2), I-2, I-3, same as IV-HT

Adjusting IV-B to IV-A for building height:

A-1, A-2, A-3, A-4, A-5, B, E, F-1, F-2, H-1, H-5, I-1(1), I-3, I-4, M, R-1, R-2, R-3, R-4, S-1, S-2, U: multiply 1.5 x Type IV-B (180 ft.)

H-1, H-2 H-3, H-5: increase by 30 ft.

H-4: increase by 40 ft.

I-1(2), I-2: same as Type IV-HT

For instance, for Groups H-1, H-2, H-3, and H-5, while the table allows 160 feet for Type I-B construction, the Committee proposed a height of 90 feet for Type IV-B construction, and is using a multiplier of 1.33 to propose a height for Type IV-A construction of 120 feet height, intentionally made equal to the existing Heavy Timber heights.

For H-4, corrosives represent a health hazard (but not necessarily a fire hazard) to building occupants and first responders, the Committee believed that reduced heights were warranted. These are slightly greater than discussed above for the H-occupancy groups (140 feet versus 120 feet for IV-A construction, and 100 feet versus 90 feet for IV-B construction), but these still are far below what is permitted for Type I-B construction (180 feet permitted for the sprinklered condition), and is in recognition of the particular type of Hazardous occupancy covered by the H-4 occupancy group.

For Group I occupancies, there are two rows in the table, one being a row that includes I-1 Condition 1 and I-3 occupants (more capable of self-preservation) and the other being a row that includes I-1 Condition 2 and I-2 occupants (less capable of self-preservation). For I-1 Condition 1 and I-3 occupants, the Committee proposed a height of 120 feet for Type IV-B (versus 180 feet from the general methodology summarized above) and a height of 180 feet for Type IV-A (versus 270 feet from the general methodology summarized above). For those I-1 Condition 2 and I-2 occupants, the Committee took a very conservative approach and will only allow the heights that are already permitted by code for traditional Type IV construction.

Background information: The ICC Board approved the establishment of an ad hoc committee for tall wood buildings in December of 2015. The purpose of the ad hoc committee is to explore the science of tall wood buildings and to investigate the feasibility and take action on developing code changes for tall wood buildings. The committee is comprised of a balance of stakeholders with additional opportunities for interested parties to participate in the four Work Groups established by the ad hoc committee, namely: Code; Fire; Standards/Definitions; and Structural. For more information, be sure to visit the ICC website <https://www.iccsafe.org/codes-tech-support/cs/icc-ad-hoc-committee-on-tall-wood-buildings/> (link active and up to date as of 12/27/17). As seen in the "Meeting Minutes and Documents" and "Resource Documents" sections of the committee web page, the ad hoc committee reviewed a substantial amount of information in order to provide technical justification for code proposals.

The ad hoc committee developed proposals for the followings code sections. The committee believes this package of code changes will result in regulations that adequately address the fire and life safety issues of tall mass timber buildings.

IBC Code Section	Description
403.3.2	Water supply requirements for fire pumps in high rise buildings of Type IVA and IVB construction.
504.3	Allowable building height (feet) for buildings of Type IVA, IVB and IVC construction. No changes to Type IV HT construction.
504.4	Allowable building height (stories) for buildings of Type IVA, IVB and IVC construction. No changes to Type IV HT.
506.2	Allowable building area for buildings of Type IVA, IVB and IVC construction. No changes to Type IV HT.
508.4.4.1 509.4.1.1 (new)	Requirements for mass timber building elements serving as fire barriers or horizontal assemblies in buildings of Type IVB or IVC construction.
602.4	Type of Construction requirements for new proposed types of construction: Types IVA, IVB and IVC. No changes to Type IV HT construction. Includes definitions for new terms: Mass timber and Noncombustible protection (mass timber). THIS IS THE KEY CODE CHANGE PROPOSAL WHICH OUTLINES THE CONSTRUCTION REQUIREMENTS FOR THE PROPOSED NEW TYPE OF MASS TIMBER BUILDINGS. THE PROPOSAL ALSO ADDRESSES CONCEALED SPACES, ADHESIVE PERFORMANCE AND EXTERIOR WALL PROTECTION.
703.8 (new)	The performance method to determine the increase to the fire resistance rating provided by noncombustible protection applied to the mass timber building element.
703.9 (new)	Requirements for sealants and adhesives to be placed at abutting edges and intersections of mass timber building elements. The reason statement references a Group B proposal to Chapter 17 for special inspection requirements of sealants and adhesives.
718.2.1	Requirements on the use of mass timber building elements used for Fireblocking.
722.7 (new)	Requirements for the fire resistance rating of mass timber elements, including minimum required protection and gypsum board attachment requirements.
3102	Requirements for membrane structures using Type IV HT construction.
3314.7 (new)	New special precautions during construction of buildings of Types IVA, IVB and IVC construction: Standpipes; Water supply for fire department connections; Noncombustible protection required for mass timber elements as construction height increases.
Appendix	Requirements for walls, floors and roofs of Type IV HT construction in buildings located in Fire Districts.
IFC Code Section	Description
701.6	Requirements which stipulate the owner's responsibility to maintain inventory of all required fire resistance rated construction in buildings of Types IVA and IVB construction. This includes an annual inspection and proper repair where necessary.
Proposed changes to be submitted in 2019 Group B	
IBC Chapter 17	Required special inspections of mass timber construction <ul style="list-style-type: none"> • Structural • Sealants and adhesives (see IBC 703.8)
IBC Chapter 23	An update to referenced standard APA PRG 320 Standard for Performance –rated Cross-laminated Timber which is currently undergoing revision to ensure the adequacy of the adhesives under fire conditions.

In addition, fire tests designed to simulate the three new construction types (Types IVA, IVB and IVC) in the ad hoc committee proposals were conducted at the Alcohol Tobacco and Firearms test lab facility. The TWB was involved in the design of the tests, and many members witnessed the test in person or online. The results of the series of 5 fire tests provide additional support for these proposals, and validate the fire performance for each of the types of construction proposed by the committee. The fire tests consisted of one-bedroom apartments on two levels, with both apartments having a corridor leading to a stair. The purpose of the tests was to address the contribution of mass timber to a fire, the performance of connections, the performance of through-penetration fire stops, and to evaluate conditions for responding fire personnel.

To review a summary of the fire tests, please visit:

<http://bit.ly/ATF-firetestreport>

To watch summary videos of the fire tests, which are accelerated to run in 3 ½ minutes, please visit:

<http://bit.ly/ATF-firetestvideos>

Both of these links were confirmed active on 12/27/17.

Cost Impact

The code change proposal will not increase or decrease the cost of construction .

This section provides information that was not previously set forth in the code, and does not change the requirements of current code, thus there is no cost impact when compared with present requirements.

Internal ID: 844

G76-18

IBC: TABLE 504.3, TABLE 504.4

Proponent: Stephen Skalko, Stephen V. Skalko, P.E. & Associates, LLC, representing Masonry Alliance for Codes and Standards (svskalko@svskalko-pe.com); Jason Krohn, representing Precast/Prestressed Concrete Institute (jkrohn@pci.org); William Hall, Portland Cement Association, representing Alliance For Concrete Codes and Standards (jhall@cement.org)

2018 International Building Code

Revise as follows:

**TABLE 504.3
ALLOWABLE BUILDING HEIGHT IN FEET ABOVE GRADE PLANE^a**

OCCUPANCY CLASSIFICATION	TYPE OF CONSTRUCTION									
	SEE FOOTNOTES	TYPE I		TYPE II		TYPE III		TYPE IV	TYPE V	
		A	B	A	B	A	B	HT	A	B
A, B, E, F, M, S, U	NS ^b	UL	160	65	55	65	55	65	50	40
	S	UL	180	85	75	85	75	85	70	60
<u>B</u>	<u>NS</u>	<u>UL</u>	<u>160</u>	<u>80</u>	<u>55</u>	<u>65</u>	<u>55</u>	<u>65</u>	<u>50</u>	<u>40</u>
	<u>S</u>	<u>UL</u>	<u>180</u>	<u>100</u>	<u>75</u>	<u>85</u>	<u>75</u>	<u>85</u>	<u>70</u>	<u>60</u>
H-1, H-2, H-3, H-5	NS ^{c, d}	UL	160	65	55	65	55	65	50	40
	S									
H-4	NS ^{c, d}	UL	160	65	55	65	55	65	50	40
	S	UL	180	85	75	85	75	85	70	60
I-1 Condition 1, I-3	NS ^{d, e}	UL	160	65	55	65	55	65	50	40
	S	UL	180	85	75	85	75	85	70	60
I-1 Condition 2, I-2	NS ^{d, e, f}	UL	160	65	55	65	55	65	50	40
	S	UL	180	85						
I-4	NS ^{d, g}	UL	160	65	55	65	55	65	50	40
	S	UL	180	85	75	85	75	85	70	60
R ^h	NS ^d	UL	160	65 <u>80</u>	55	65	55	65	50	40
	S	UL	180	85 <u>100</u>	75	85	75	85	70	60

For SI: 1 foot = 304.8 mm.

UL = Unlimited; NS = Buildings not equipped throughout with an automatic sprinkler system; S = Buildings equipped throughout with an automatic sprinkler system installed in accordance with Section 903.3.1.1; S13R = Buildings equipped throughout with an automatic sprinkler system installed in accordance with

- a. See Chapters 4 and 5 for specific exceptions to the allowable height in this chapter.
- b. See Section 903.2 for the minimum thresholds for protection by an automatic sprinkler system for specific occupancies.
- c. New Group H occupancies are required to be protected by an automatic sprinkler system in accordance with Section 903.2.5.
- d. The NS value is only for use in evaluation of existing building height in accordance with the International Existing Building Code.
- e. New Group I-1 and I-3 occupancies are required to be protected by an automatic sprinkler system in accordance with Section 903.2.6. For new Group I-1 occupancies Condition 1, see Exception 1 of Section 903.2.6.
- f. New and existing Group I-2 occupancies are required to be protected by an automatic sprinkler system in accordance with Section 903.2.6 and Section 1103.5 of the *International Fire Code*.
- g. For new Group I-4 occupancies, see Exceptions 2 and 3 of Section 903.2.6.
- h. New Group R occupancies are required to be protected by an automatic sprinkler system in accordance with Section 903.2.8.

**TABLE 504.4
ALLOWABLE NUMBER OF STORIES ABOVE GRADE PLANEa, b**

OCCUPANCY CLASSIFICATION	TYPE OF CONSTRUCTION									
	SEE FOOTNOTES	TYPE I		TYPE II		TYPE III		TYPE IV	TYPE V	
		A	B	A	B	A	B	HT	A	B
A-1	NS	UL	5	3	2	3	2	3	2	1
	S	UL	6	4	3	4	3	4	3	2
A-2	NS	UL	11	3	2	3	2	3	2	1
	S	UL	12	4	3	4	3	4	3	2
A-3	NS	UL	11	3	2	3	2	3	2	1
	S	UL	12	4	3	4	3	4	3	2
A-4	NS	UL	11	3	2	3	2	3	2	1
	S	UL	12	4	3	4	3	4	3	2
A-5	NS	UL	UL	UL	UL	UL	UL	UL	UL	UL
	S	UL	UL	UL	UL	UL	UL	UL	UL	UL
B	NS	UL	11	5 6	3	5	3	5	3	2
	S	UL	12	6 7	4	6	4	6	4	3
E	NS	UL	5	3	2	3	2	3	1	1
	S	UL	6	4	3	4	3	4	2	2
F-1	NS	UL	11	4	2	3	2	4	2	1
	S	UL	12	5	3	4	3	5	3	2
F-2	NS	UL	11	5	3	4	3	5	3	2
	S	UL	12	6	4	5	4	6	4	3
H-1	NS ^{c, d}	1	1	1	1	1	1	1	1	NP
	S									
H-2	NS ^{c, d}	UL	3	2	1	2	1	2	1	1
	S									
H-3	NS ^{c, d}	UL	6	4	2	4	2	4	2	1
	S									
H-4	NS ^{c, d}	UL	7	5	3	5	3	5	3	2
	S	UL	8	6	4	6	4	6	4	3
H-5	NS ^{c, d}	4	4	3	3	3	3	3	3	2
	S									
I-1 Condition 1	NS ^{d, e}	UL	9	4	3	4	3	4	3	2
	S	UL	10	5	4	5	4	5	4	3
I-1 Condition 2	NS ^{d, e}	UL	9	4	3	4	3	4	3	2
	S	UL	10	5						
I-2	NS ^{d, f}	UL	4	2	1	1	NP	1	1	NP
	S	UL	5	3						
I-3	NS ^{d, e}	UL	4	2	1	2	1	2	2	1
	S	UL	5	3	2	3	2	3	3	2
I-4	NS ^{d, g}	UL	5	3	2	3	2	3	1	1
	S	UL	6	4	3	4	3	4	2	2
M	NS	UL	11	4	2	4	2	4	3	1
	S	UL	12	5	3	5	3	5	4	2
R-1 ^h	NS ^d	UL	11	4	4	4	4	4	3	2
	S	UL	12	5 6	5	5	5	5	4	3
R-2 ^h	NS ^d	UL	11	4	4	4	4	4	3	2

	S	UL	12	<u>5 6</u>	5	5	5	5	4	3
R-3 ^h	NS ^d	UL	11	4	4	4	4	4	3	3
	S	UL	12	<u>5 6</u>	5	5	5	5	4	4
R-4 ^h	NS ^d	UL	11	4	4	4	4	4	3	2
	S	UL	12	<u>5 6</u>	5	5	5	5	4	3
S-1	NS	UL	11	4	2	3	2	4	3	1
	S	UL	12	5	3	4	3	5	4	2
S-2	NS	UL	11	5	3	4	3	4	4	2
	S	UL	12	6	4	5	4	5	5	3
U	NS	UL	5	4	2	3	2	4	2	1
	S	UL	6	5	3	4	3	5	3	2

UL = Unlimited; NP = Not Permitted; NS = Buildings not equipped throughout with an automatic sprinkler system; S = Buildings equipped throughout with an automatic sprinkler system installed in accordance with Section 903.3.1.1; S13R = Buildings equipped throughout with an automatic sprinkler system installed in accordance with Section 903.3.1.2; S13D = Buildings equipped throughout with an automatic sprinkler system installed in accordance with Section 903.3.1.3.

- a. See Chapters 4 and 5 for specific exceptions to the allowable height in this chapter.
- b. See Section 903.2 for the minimum thresholds for protection by an automatic sprinkler system for specific occupancies.
- c. New Group H occupancies are required to be protected by an automatic sprinkler system in accordance with Section 903.2.5.
- d. The NS value is only for use in evaluation of existing building height in accordance with the International Existing Building Code.
- e. New Group I-1 and I-3 occupancies are required to be protected by an automatic sprinkler system in accordance with Section 903.2.6. For new Group I-1 occupancies, Condition 1, see Exception 1 of Section 903.2.6.
- f. New and existing Group I-2 occupancies are required to be protected by an automatic sprinkler system in accordance with Section 903.2.6 and 1103.5 of the International Fire Code.
- g. For new Group I-4 occupancies, see Exceptions 2 and 3 of Section 903.2.6.
- h. New Group R occupancies are required to be protected by an automatic sprinkler system in accordance with Section 903.2.8.

Reason:

Since development of the early building codes, and even with the International Building Code today, building size has typically been determined based on a combination of factors; (a) the occupancy type for the building; (b) the materials used to construct the building; and (c), the presence of automatic sprinkler protection. Regarding occupancy types, the fire loads associated with contents found in a particular occupancy group and the relative risk of danger to the occupants from fire because of the occupancy characteristics are considered. For the materials used to construct the building the presence of combustible materials used in the construction of the building structure itself are key. As the quantity of combustible materials decreases the relative risk of fire size, spread of fire to adjacent properties, and danger to the fire service are less such that the building sizes are allowed to increase. Another factor considered from a building materials aspect is the degree of fire resistance provided. When structural fire resistance is provided to the load carrying structural members the risk of damage to the structure or potential for collapse is also considered reduced. Finally, sprinkler protection has been utilized as a factor in allowing increases in the size of buildings. A good discussion of these concepts can be found in the report "Fire-Resistance Classifications of Building Construction", Report BMS92, National Bureau of Standards, October 7, 1942.

One thing of importance in the report is that buildings constructed of noncombustible materials and provided with at least 1-hour of fire resistance (classified as Fireproof construction in the report) were considered to be a much lower risk to the safety of the occupants and fire service, and to the spread of fire, than buildings constructed of noncombustible materials with little or no fire resistance (classified as Incombustible construction in the report). The same was said for buildings constructed with a combination of noncombustible exterior walls and interior combustible structural materials (classified as Exterior-Protected construction in the report). Hence the report advised that these noncombustible buildings with at least 1-hour fire resistance could be built to taller heights due to the lack of combustible materials in the structural systems combined with some level of fire resistance.

Unfortunately, when you look at Tables 504.3 and 504.4 in the 2018 International Building Code, building occupancies with low internal fire loads such as Group B, Business and Group R, Residential, when constructed of one-hour fire rated noncombustible construction (i.e. Type IIA), are not given due credit for the enhanced fire risk attributes when compared to buildings of one-hour fire resistance construction using a combination of noncombustible exterior walls and interior combustible structural materials (i.e. Types IIIA and Type IV). This is especially apparent when comparing these Group B and R occupancies to Group F, Factory and Group S, Storage Occupancies in Table 504.4.

Recognizing the lower fire risk of Type IIA construction compared to Type IIIA and Type IV construction, this code change proposes permitting Group B and Group R buildings of Type IIA construction to be built one story and 15-feet higher. These increases are attributed to elimination of the fire load present in the structural components, combined with the 1-hour fire resistance for these noncombustible structural elements, consistent with the fire safety premises for building construction types in BMS92. The new story heights are increased in proportion to the story heights/number of stories for existing buildings of Type IIA Group B and Group R, with rounding to be consistent with other values in Table 504.3.

Cost Impact

The code change proposal will decrease the cost of construction .

Presently Group B and R occupancy buildings of noncombustible construction with 1-hour fire resistance (i.e. Type IIA) are only allowed to be built to the same story height as buildings of Group B and R occupancy with a combination combustible/noncombustible construction and a 1-hour fire resistance (i.e. Type IIIA and IV). However, to build Group B or R occupancy buildings of noncombustible construction taller, the fire resistance of the structural elements (i.e. columns and floors) are required to be increased to 2-hours (i.e. Type IB construction).

This proposal recognizes the improved fire safety of Group B and R occupancy buildings of Type IIA construction, compared to Types IIIA and IV construction of the same occupancy groups, since Type IIA buildings have a reduced fire load associated with the reduced use of combustible structural components. Allowing one additional story height of Group B and R occupancy buildings without having to increase the fire resistance of columns and floors will reduce the cost of construction of these noncombustible buildings Group B and R occupancies.

Internal ID: 1541

G77-18

IBC: 504.4

Proponent: Micah Chappell, representing City of Seattle (micah.chappell@seattle.gov)

2018 International Building Code

Revise as follows:

504.4 Number of stories. The maximum number of *stories* above grade plane of a building shall not exceed the limits specified in Table 504.4.

Reason:

This very simple change matches the language of Section 504.4 to the language of Table 504.4. Absent this correction any “limit specified in the Table” could be misconstrued as the “number of stories of a building” by Section 504.4, and thereby include basement story(s).

Cost Impact

The code change proposal will not increase or decrease the cost of construction .

The change is a simple clarification of existing code requirements. No cost impact.

Internal ID: 1660

G78-18

IBC: TABLE 504.4

Proponent: Andrew Klein, representing Self Storage Association (andrew@asklein.com)

2018 International Building Code

Revise as follows:

TABLE 504.4
ALLOWABLE NUMBER OF STORIES ABOVE GRADE PLANE^a PLANE^{a, b}

OCCUPANCY CLASSIFICATION	TYPE OF CONSTRUCTION									
	SEE FOOTNOTES	TYPE I		TYPE II		TYPE III		TYPE IV	TYPE V	
		A	B	A	B	A	B	HT	A	B
A-1	NS	UL	5	3	2	3	2	3	2	1
	S	UL	6	4	3	4	3	4	3	2
A-2	NS	UL	11	3	2	3	2	3	2	1
	S	UL	12	4	3	4	3	4	3	2
A-3	NS	UL	11	3	2	3	2	3	2	1
	S	UL	12	4	3	4	3	4	3	2
A-4	NS	UL	11	3	2	3	2	3	2	1
	S	UL	12	4	3	4	3	4	3	2
A-5	NS	UL	UL	UL	UL	UL	UL	UL	UL	UL
	S	UL	UL	UL	UL	UL	UL	UL	UL	UL
B	NS	UL	11	5	3	5	3	5	3	2
	S	UL	12	6	4	6	4	6	4	3
E	NS	UL	5	3	2	3	2	3	1	1
	S	UL	6	4	3	4	3	4	2	2
F-1	NS	UL	11	4	2	3	2	4	2	1
	S	UL	12	5	3	4	3	5	3	2
F-2	NS	UL	11	5	3	4	3	5	3	2
	S	UL	12	6	4	5	4	6	4	3
H-1	NS ^{c, d}	1	1	1	1	1	1	1	1	NP
	S									
H-2	NS ^{c, d}	UL	3	2	1	2	1	2	1	1
	S									
H-3	NS ^{c, d}	UL	6	4	2	4	2	4	2	1
	S									
H-4	NS ^{c, d}	UL	7	5	3	5	3	5	3	2
	S	UL	8	6	4	6	4	6	4	3
H-5	NS ^{c, d}	4	4	3	3	3	3	3	3	2
	S									
I-1 Condition 1	NS ^{d, e}	UL	9	4	3	4	3	4	3	2
	S	UL	10	5	4	5	4	5	4	3
I-1 Condition 2	NS ^{d, e}	UL	9	4	3	4	3	4	3	2
	S	UL	10	5						
I-2	NS ^{d, f}	UL	4	2	1	1	NP	1	1	NP
	S	UL	5	3						
I-3	NS ^{d, e}	UL	4	2	1	2	1	2	2	1
	S	UL	5	3	2	3	2	3	3	2
I-4	NS ^{d, g}	UL	5	3	2	3	2	3	1	1
	S	UL	6	4	3	4	3	4	2	2
M	NS	UL	11	4	2	4	2	4	3	1
	S	UL	12	5	3	5	3	5	4	2
R-1 ^h	NS ^d	UL	11	4	4	4	4	4	3	2
	S13R	4	4						4	3
	S	UL	12	5	5	5	5	5	4	3

R-2 ^h	NS ^d	UL	11	4	4	4	4	4	3	2
	S13R	4	4	4					4	3
	S	UL	12	5	5	5	5	5	4	3
R-3 ^h	NS ^d	UL	11	4	4	4	4	4	3	3
	S13D	4	4						3	3
	S13R	4	4						4	4
	S	UL	12	5	5	5	5	5	4	4
R-4 ^h	NS ^d	UL	11	4	4	4	4	4	3	2
	S13D	4	4						3	2
	S13R	4	4						4	3
	S	UL	12	5	5	5	5	5	4	3
S-1	NS	UL	11	4	2	3	2	4	3	1
	S	UL	12	5	3 4	4	3	5	4	2
S-2	NS	UL	11	5	3	4	3	4	4	2
	S	UL	12	6	4	5	4	5	5	3
U	NS	UL	5	4	2	3	2	4	2	1
	S	UL	6	5	3	4	3	5	3	2

Footnotes of the table are unchanged.

Reason:

This code change proposal returns the maximum number of stories of sprinklered S-1 buildings to the 2006 IBC value of 4 stories. In 2009, the Code Technology Committee Balanced Fire Protection Features Study Group reduced the maximum number of stories permitted in some occupancies for unprotected construction (IIB & IIIB). The justification was that the I-Codes permitted only a single-story sprinkler height increase, so in order to match the permitted number of stories in the legacy codes for sprinklered buildings, unsprinklered buildings exceeded what was allowed. At the time, the study group chose not to propose modifying the sprinkler increase in the IBC. With the reformatting of the height-and-area provisions of the Code in 2015, we are now able to return to the 2006 maximum number of stories for a sprinklered building without affecting unsprinklered buildings.

This proposal seeks only to return to the 2006 story limit for sprinklered, S-1 noncombustible Type IIB buildings. These buildings were commonly constructed prior to the adoption by jurisdictions of the 2009 IBC, and we have seen no adverse effect on life safety or property protection.

Unsprinklered IBC Table 503 Values

Use Group	IBC	IBC
B	3	5
M	2	2
S-1	2	2
S-2	3	3
R* (13)	3	3

* - Applies for R-1, R-2 and R-3 Use Groups

In essence, these reductions would eliminate the anomalies created by the multi-story SBC sprinkler increase and drop the IBC value back to the next least restrictive legacy code (in these cases, the NBC).

The study group noted that the motivation for these recommendations was to address anomalies associated with unsprinklered 4 and 5 story buildings of nonrated construction. No evidence was submitted to suggest that the existing sprinklered height allowances for these buildings in either the IBC or the legacy codes had created an unsafe condition that requires correction.

Cost Impact: The code change proposal will increase the cost of construction.

Public Hearing: Committee: AS AM D
Assembly: ASF AMF DF

G119-07/08

Table 503

Proponent: Kate Dargan and David Collins, Co-Chairs, Code Technology Committee (CTC) Balanced Fire Protection Features Study Group

Revise table as follows:

**TABLE 503
 ALLOWABLE HEIGHT AND BUILDING AREAS^a
 Height limitations shown as stories and feet above grade planes.
 Area limitations as determined by the definition of "Area, building," per story**

GROUP	HGT(feet)	TYPE OF CONSTRUCTION								
		TYPE I		TYPE II		TYPE III		TYPE IV	TYPE V	
		A	B	A	B	A	B	HT	A	B
	HGT(S)	UL	160	65	55	65	55	65	50	40
S-1	S	UL	11	4	3-2	3	3-2	4	3	1
	A	UL	48,000	26,000	17,500	26,000	17,500	25,500	14,000	8,000

(Portions of table and footnotes not shown remain unchanged)

Reason: One area of concern identified for study by the Height and Area Task Group was 4 and 5 story buildings of unrated construction. The table below shows the occupancies in the IBC where that condition exists for sprinklered construction. In addition, the table shows the sprinklered height allowances for these occupancies in the legacy codes.

**Type IIB, Type IIB (Unprotected Construction)
 Story Comparison (w/ NFPA 13 Sprinklers)**

	SBC	NBC	UBC	2006 IBC
B	5	4	2	5
F-2	4	4	2	4
M	5	3	2	5
S-1	4	3	2	4
S-2	4	4	2	5
R* (13)	5	4	4	5
R(13R)	4	4	3	4

NA- Not Applicable NP- Not Permitted
 * - Applies for R-1, R-2 and R-3 Use Groups

The study group noted that for Use Group B, M, S-1, and R buildings of Type IIB or Type IIB construction, the allowance for 4 or 5 stories in the IBC was premised on the story heights allowed in the SBC. In all these instances, the SBC sprinklered height allowance for these Use Groups relied on a multiple story sprinkler increase. For example, for Use Group B, the SBC allowed 2 stories for unsprinklered construction and 5 stories for sprinklered construction. This exceeds the consistent one story sprinkler height increase incorporated in the IBC height and area provisions. Based on this review, the study group identified two anomalies from what was permitted by the legacy codes. First, the story height allowance for S-

2 use groups is not based on any of the legacy code allowances. Second, for Use Group B, M, S-1, and R (Type IIB and IIB construction), the IBC story height allowance for unsprinklered construction exceeds what was allowed by any of the legacy codes. For example, the maximum height for an unsprinklered Type IIB office building in any of the legacy codes was the NBC allowance for 3 stories. Currently, the IBC allows 4 stories for this condition. Rather than modify the sprinkler increase in the IBC, the study group suggested the following recommended story height changes:

Unsprinklered IBC Table 503 Values

Use Group	IIB	IIB
B	3	3
M	2	2
S-1	2	2
S-2	3	3
R* (13)	3	3

* - Applies for R-1, R-2 and R-3 Use Groups

In essence, these reductions would eliminate the anomalies created by the multi-story SBC sprinkler increase and drop the IBC value back to the next least restrictive legacy code (in these cases, the NBC).

The study group noted that the motivation for these recommendations was to address anomalies associated with unsprinklered 4 and 5 story buildings of nonrated construction. No evidence was submitted to suggest that the existing sprinklered height allowances for these buildings in either the IBC or the legacy codes had created an unsafe condition that requires correction.

Cost Impact: The code change proposal will increase the cost of construction.

Public Hearing: Committee: AS AM D
 Assembly: ASF AMF DF

G120-07/08

Table 503

Proponent: Kate Dargan and David Collins, Co-Chairs, Code Technology Committee (CTC) Balanced Fire Protection Features Study Group

Revise table as follows:

**TABLE 503
 ALLOWABLE HEIGHT AND BUILDING AREAS^a
 Height limitations shown as stories and feet above grade plane.
 Area limitations as determined by the definition of "Area, building," per story**

GROUP	HGT(feet)	TYPE OF CONSTRUCTION									
		TYPE I		TYPE II		TYPE III		TYPE IV	TYPE V		
		A	B	A	B	A	B	HT	A	B	
	HGT(S)	UL	160	85	55	85	55	85	50	40	
S-2 ^{a, c}	S	UL	11	5	4-3	4	4-3	5	4	2	
	A	UL	79,000	39,000	26,000	39,000	26,000	38,500	21,000	13,500	

(Portions of table and footnotes not shown remain unchanged)

Reason: One area of concern identified for study by the Height and Area Task Group was 4 and 5 story buildings of unrated construction. The table below shows the occupancies in the IBC where that condition exists for sprinklered construction. In addition, the table shows the sprinklered height allowances for these occupancies in the legacy codes.

**Type IIB, Type IIB (Unprotected Construction)
 Story Comparison (w/ NFPA 13 Sprinklers)**

	SBC	NBC	UBC	2006 IBC
B	5	4	2	5
F-2	4	4	2	4
M	5	3	2	5
S-1	4	3	2	4
S-2	4	4	2	5
R* (13)	5	4	4	5
R(13R)	4	4	3	4

NA- Not Applicable NP- Not Permitted

* - Applies for R-1, R-2 and R-3 Use Groups

Cost Impact

The code change proposal will decrease the cost of construction .

For S-1 buildings, this code change proposal allows a 4-story building to be Type IIB instead of having to be IIA, thus reducing the cost of requiring fire-rated construction.

G79-18

IBC: 504.4

Proponent: Keith Flanders, Cosentini Associates, representing self (kflanders@cosentini.com)

2018 International Building Code

Revise as follows:

504.4 Number of stories. The maximum number of *stories* of a building shall not exceed the limits specified in Table 504.4. An occupied roof is considered a story above grade unless otherwise specified as a portion of the story below by the provisions of this code.

Reason:

There is often a debate when an occupied roof may exceed the prescribed number of stories above grade plane. Adding this language seeks to clarify that an occupied roof should be considered a story above grade when determining the allowable number of stories for a building based on the type of construction.

If an occupied roof can be considered a mezzanine, it is not required to be considered a story above grade for the purposes of determining the allowable number of stories.

Cost Impact

The code change proposal will not increase or decrease the cost of construction .

This proposal simply provides clarification and is not intended as a change.

Internal ID: 1021

G80-18

IBC: TABLE 504.4

Proponent: Stephen DiGiovanni, representing ICC Ad Hoc Committee on Tall Wood Buildings (TWB) (TWB@iccsafe.org)

2018 International Building Code

Revise as follows:

**TABLE 504.4
ALLOWABLE NUMBER OF STORIES ABOVE GRADE PLANE^{a, b}**

OCCUPANCY CLASSIFICATION	TYPE OF CONSTRUCTION									TYPE OF CONSTRUCTION	TYPE OF CONSTRUCTION	TYP COM	
	SEE FOOTNOTES	TYPE I		TYPE II		TYPE III		TYPE IV		TYPE IV	TYPE IV	TYPE V	
		A	B	A	B	A	B	A	B			C	HT
A-1	NS	UL	5	3	2	3	2	<u>3</u>	<u>3</u>	<u>3</u>	3	2	1
	S	UL	6	4	3	4	3	<u>9</u>	<u>6</u>	<u>4</u>	4	3	2
A-2	NS	UL	11	3	2	3	2	<u>3</u>	<u>3</u>	<u>3</u>	3	2	1
	S	UL	12	4	3	4	3	<u>18</u>	<u>12</u>	<u>6</u>	4	3	2
A-3	NS	UL	11	3	2	3	2	<u>3</u>	<u>3</u>	<u>3</u>	3	2	1
	S	UL	12	4	3	4	3	<u>18</u>	<u>12</u>	<u>6</u>	4	3	2
A-4	NS	UL	11	3	2	3	2	<u>3</u>	<u>3</u>	<u>3</u>	3	2	1
	S	UL	12	4	3	4	3	<u>18</u>	<u>12</u>	<u>6</u>	4	3	2
A-5	NS	UL	UL	UL	UL	UL	UL	<u>1</u>	<u>1</u>	<u>1</u>	UL	UL	UL
	S	UL	UL	UL	UL	UL	UL	<u>UL</u>	<u>UL</u>	<u>UL</u>	UL	UL	UL
B	NS	UL	11	5	3	5	3	<u>5</u>	<u>5</u>	<u>5</u>	5	3	2
	S	UL	12	6	4	6	4	<u>18</u>	<u>12</u>	<u>9</u>	6	4	3
E	NS	UL	5	3	2	3	2	<u>3</u>	<u>3</u>	<u>3</u>	3	1	1
	S	UL	6	4	3	4	3	<u>9</u>	<u>6</u>	<u>4</u>	4	2	2
F-1	NS	UL	11	4	2	3	2	<u>3</u>	<u>3</u>	<u>3</u>		2	1
	S	UL	12	5	3	4	3	<u>10</u>	<u>7</u>	<u>5</u>	5	3	2
F-2	NS	UL	11	5	3	4	3	<u>5</u>	<u>5</u>	<u>5</u>	5	3	2
	S	UL	12	6	4	5	4	<u>12</u>	<u>8</u>	<u>6</u>	6	4	3
H-1	NS ^{c, d}	1	1	1	1	1	1	<u>NP</u>	<u>NP</u>	<u>NP</u>	1	1	NP
	S							<u>1</u>	<u>1</u>	<u>1</u>			
H-2	NS ^{c, d}	UL	3	2	1	2	1	<u>1</u>	<u>1</u>	<u>1</u>	2	1	1
	S							<u>2</u>	<u>2</u>	<u>2</u>			
H-3	NS ^{c, d}	UL	6	4	2	4	2	<u>3</u>	<u>3</u>	<u>3</u>	4	2	1
	S							<u>4</u>	<u>4</u>	<u>4</u>			
H-4	NS ^{c, d}	UL	7	5	3	5	3	<u>5</u>	<u>5</u>	<u>5</u>	5	3	2
	S	UL	8	6	4	6	4	<u>8</u>	<u>7</u>	<u>6</u>	6	4	3
H-5	NS ^{c, d}	4	4	3	3	3	3	<u>2</u>	<u>2</u>	<u>2</u>	3	3	2
	S							<u>3</u>	<u>3</u>	<u>3</u>			
I-1 Condition 1	NS ^{d, e}	UL	9	4	3	4	3	<u>4</u>	<u>4</u>	<u>4</u>	4	3	2
	S	UL	10	5	4	5	4	<u>10</u>	<u>7</u>	<u>5</u>	5	4	3
I-1 Condition 2	NS ^{d, e}	UL	9	4	3	4	3	<u>3</u>	<u>3</u>	<u>3</u>	4	3	2
	S	UL	10	5				<u>10</u>	<u>6</u>	<u>4</u>			
I-2	NS ^{d, f}	UL	4	2	1	1	NP	<u>NP</u>	<u>NP</u>	<u>NP</u>	1	1	NP
	S	UL	5	3				<u>7</u>	<u>5</u>	<u>1</u>			
I-3	NS ^{d, e}	UL	4	2	1	2	1	<u>2</u>	<u>2</u>	<u>2</u>	2	2	1
	S	UL	5	3	2	3	2	<u>7</u>	<u>5</u>	<u>3</u>	3	3	2
I-4	NS ^{d, g}	UL	5	3	2	3	2	<u>3</u>	<u>3</u>	<u>3</u>	3	1	1
	S	UL	6	4	3	4	3	<u>9</u>	<u>6</u>	<u>4</u>	4	2	2
M	NS	UL	11	4	2	4	2	<u>4</u>	<u>4</u>	<u>4</u>	4	3	1
	S	UL	12	5	3	5	3	<u>12</u>	<u>8</u>	<u>6</u>	5	4	2
R-1 ^h	NS ^d	UL	11	4	4	4	4	<u>4</u>	<u>4</u>	<u>4</u>	4	3	2
	S13R	4	4									4	3

	S	UL	12	5	5	5	5	<u>18</u>	<u>12</u>	<u>8</u>	5	4	3
R-2 ^h	NS ^d	UL	11	4	4	4	4	<u>4</u>	<u>4</u>	<u>4</u>	4	3	2
	S13R	4	4	4								4	3
	S	UL	12	5	5	5	5	<u>18</u>	<u>12</u>	<u>8</u>	5	4	3
R-3 ^h	NS ^d	UL	11	4	4	4	4	<u>4</u>	<u>4</u>	<u>4</u>	4	3	3
	S13D	4	4									3	3
	S13R	4	4									4	4
	S	UL	12	5	5	5	5	<u>18</u>	<u>12</u>	<u>5</u>	5	4	4
R-4 ^h	NS ^d	UL	11	4	4	4	4	<u>4</u>	<u>4</u>	<u>4</u>	4	3	2
	S13D	4	4									3	2
	S13R	4	4									4	3
	S	UL	12	5	5	5	5	<u>18</u>	<u>12</u>	<u>5</u>	5	4	3
S-1	NS	UL	11	4	2	3	2	<u>4</u>	<u>4</u>	<u>4</u>	4	3	1
	S	UL	12	5	3	4	3	<u>10</u>	<u>7</u>	<u>5</u>	5	4	2
S-2	NS	UL	11	5	3	4	3	<u>4</u>	<u>4</u>	<u>4</u>	4	4	2
	S	UL	12	6	4	5	4	<u>12</u>	<u>8</u>	<u>5</u>	5	5	3
U	NS	UL	5	4	2	3	2	<u>4</u>	<u>4</u>	<u>4</u>	4	2	1
	S	UL	6	5	3	4	3	<u>9</u>	<u>6</u>	<u>5</u>	5	3	2

~~UL-TUL~~ = Unlimited; NP = Not Permitted; NS = Buildings not equipped throughout with an automatic sprinkler system; S = Buildings equipped throughout with an automatic sprinkler system installed in accordance with Section 903.3.1.1; S13R = Buildings equipped throughout with an automatic sprinkler system installed in accordance with Section 903.3.1.2; S13D = Buildings equipped throughout with an automatic sprinkler system installed in accordance with Section 903.3.1.3.

- a. See Chapters 4 and 5 for specific exceptions to the allowable height in this chapter.
- b. See Section 903.2 for the minimum thresholds for protection by an automatic sprinkler system for specific occupancies.
- c. New Group H occupancies are required to be protected by an automatic sprinkler system in accordance with Section 903.2.5.
- d. The NS value is only for use in evaluation of existing building height in accordance with the International Existing Building Code.
- e. New Group I-1 and I-3 occupancies are required to be protected by an automatic sprinkler system in accordance with Section 903.2.6. For new Group I-1 occupancies, Condition 1, see Exception 1 of Section 903.2.6.
- f. New and existing Group I-2 occupancies are required to be protected by an automatic sprinkler system in accordance with Section 903.2.6 and 1103.5 of the International Fire Code.
- g. For new Group I-4 occupancies, see Exceptions 2 and 3 of Section 903.2.6.
- h. New Group R occupancies are required to be protected by an automatic sprinkler system in accordance with Section 903.2.8.

Reason:

The Ad Hoc Committee on Tall Wood Buildings (TWB) was created by the ICC Board to explore the science of tall wood buildings and take action on developing code changes for tall wood buildings. The TWB has created several code change proposals with respect to the concept of tall buildings of mass timber and the background information is at the end of this Statement. Within the statement are important links to information, including documents and videos, used in the deliberations which resulted in these proposals.

The TWB and its various WGs held meetings, studied issues and sought input from various expert sources around the world. The TWB has posted those documents and input on its website for interested parties to follow its progress and to allow those parties to, in turn, provide input to the TWB.

At its first meeting, the TWB discussed a number of performance objectives to be met with the proposed criteria for tall wood buildings:

No collapse under reasonable scenarios of complete burn-out of fuel without automatic sprinkler protection being considered.

No unusually high radiation exposure from the subject building to adjoining properties to present a risk of ignition under reasonably severe fire scenarios.

No unusual response from typical radiation exposure from adjacent properties to present a risk of ignition of the subject building under reasonably severe fire scenarios.

No unusual fire department access issues.

Egress systems designed to protect building occupants during the design escape time, plus a factor of safety.

Highly reliable fire suppression systems to reduce the risk of failure during reasonably expected fire scenarios. The degree of reliability should be proportional to evacuation time (height) and the risk of collapse.

The comprehensive package of proposals from the TWB meet these performance objectives.

The TWB also determined that fire testing was necessary to validate these concepts. At its first meeting, members discussed the nature and intention of fire testing so as to ensure meaningful results for the TWB and, more specifically, for the fire service. Subsequently a test plan was developed. The fire tests consisted of one-bedroom apartments on two levels, with both apartments having a corridor leading to a stair. The purpose of the tests was to address the contribution of mass timber to a fire, the performance of connections, the performance of joints, and to evaluate conditions for responding fire personnel. The Fire WG then refined the test plan, which was implemented with a series of five, full-scale, multiple-story building tests at the Alcohol, Tobacco and Firearms (ATF) laboratories in Beltsville, MD. The results of those tests, as well as testing conducted by others, helped form the basis upon which the Codes WG developed its code change proposals. This code change proposal is one of those developed by the Codes WG and approved by the TWB.

To review a summary of the fire tests, please visit:

<http://bit.ly/ATF-firetestreport>

To watch summary videos of the fire tests, which are accelerated to run in 3-1/2 minutes each, please visit: <http://bit.ly/ATF-firetestvideos>.

Both of these links were confirmed active on 12/27/17.

Number of Stories

This proposal addresses the building height, in terms of the number of stories, for the three new construction types proposed by the TWB. As set forth in the proposal to Section 602.4, the three new types of construction are Types IV-A, IV-B, and IV-C. The Committee examined each proposed type of construction for its safety and efficacy with regard to each occupancy.

The following approach was considered appropriate for the heights of the new construction types, based on the conclusions of the Committee:

Based upon TWB review of fire safety and structural integrity performance, Type IV-B is equated to Type I-B for height (in number of stories). A noteworthy item is that, per Section 403.2.1.1 of the IBC, Type I-B construction is permitted to be reduced to 1-hour Fire Resistance Rating (FRR); however, the TWB does not propose to allow the same reduction for Type IV-B. As a result, the comparison is between 2-hr mass timber construction that is permitted to be partially unprotected, versus 1-hr Type IB construction, and the Committee believes that 2-hr mass timber construction that is partially exposed per the limits of proposed Section 602.4 warrants the same heights as allowed for 1-hr Type I-B construction;

Type IV-A should be somewhat larger than IV-B, as Type IV-A construction is entirely protected (no exposed mass timber permitted) and the required rating of the structure is equivalent to those required of Type I-A construction (3-hr rating for structural frame). However, the Committee did not find it acceptable to allow the scale of heights (many of which are unlimited) of Type I-A to be applied to Type IV-A. Instead, the Committee applied a multiplier of 1.5 to the heights proposed for Type IV-B construction (rounded up or down based on judgment) in order to propose reasonable height allowances for IV-A construction;

The Committee viewed Type IV-C as sufficiently similar to existing HT construction, especially in terms of the percentage of exposed wood (it is permitted to be entirely unprotected), and the resulting contribution to fire. While the height in feet for Type IV-C is proposed to be equal to the height in feet of Type IV-HT, the Committee felt that additional stories was warranted in some cases. Therefore, in terms of stories, the Committee proposes additional number of stories for Type IV-C construction when compared to traditional Type IV heavy timber construction. The Committee feels that some recognition is warranted for the fire resistance rating requirements (Type IV-C has 2-hour rating on structural elements, whereas traditional Type IV Heavy Timber used dimensional wood, which is understood to yield an approximate fire resistance rating equivalent to about 1-hour construction) and provided that flexibility when developing height, in terms of stories, for Type IV-C construction. A multiplier of 1.5 was applied from the Type IV-HT heights to develop reasonable numbers of stories for Type IV-C construction.

While the base code seems to allow significant heights for buildings without sprinklers (e.g., Table 504.4 currently allows 11 stories for NS Type I-B construction for many occupancy classifications), the Committee believes that no additional heights over what is already permitted for Type IV should be proposed for the NS (non sprinklered) rows. As such, where separate rows are provided for heights for the NS condition, the proposed heights for Types IV-A, IV-B, and IV-C are the same as those heights already permitted for Type IV for the NS condition.

This methodology explains the majority of the recommendations included in this proposal. Specifically, for occupancy groups A, B, E, R, and U, the methodology described above accurately reflects how the height proposals were developed.

The Committee applied professional judgment (from both a fire safety and a structural perspective) to develop a draft table, cell by cell, for all occupancy types. After further examination, reduced heights were proposed for F, H, I, M, and S occupancy classifications.

For F-1 occupancies, the Committee proposed a height of 7 stories for Type IV-B construction (versus the 12 stories currently permitted for I-B construction). A multiplier of 1.5 was used to propose a height of 10 stories for Type IV-A construction (when rounded down). No additional height was proposed for Type IV-C construction (Type IV-C proposed at 5 stories, and 5 stories is already permitted by code for Type IV-HT).

For F-2 occupancies, again the Committee is proposing a reduced number of stories, with 8 stories for Type IV-B construction (versus 12 stories that would be derived from the methodology). Again, a multiplier of 1.5 was used to propose a height of 12 stories for Type IV-A construction. No additional height is proposed for Type IV-C construction (Type IV-C proposed at 6 stories, and 6 stories is already permitted by code for Type IV-HT).

A conservative approach also explains the proposed heights for Group H occupancies. For Group H-1, only 1 story buildings are permitted by Table 504.4 for all construction types, so the proposal was adjusted to also limit all of the new Type IV construction types to 1 story as well.

For Groups H-2, H-3, and H-5, heights were intentionally made equal to the existing Heavy Timber heights. In other words, there is no proposal to any increased heights over what is already allowed by code for these use groups.

Group H-4, being corrosives which represents a health hazard (but not necessarily a fire hazard) to occupants and first responders, was also reduced, slightly. The TWB proposes 7 stories for Type IV-B construction (equivalency to Type I-B would have yielded 8 stories). The proposal allows only 8 stories for Type IV-A construction. No additional height is proposed for Type IV-C construction (Type IV-C proposed at 6 stories, and 6 stories is already permitted by code for Type IV-HT).

For Group I, the Committee took a more conservative approach and proposed an equivalent number of stories for Type IV-A construction, as is provided for Type I-B construction (10 stories for both construction types and occupancy types). The allowable heights for Type IV-B construction were selected to fall between the 10 stories for Type IV-A and the number of stories for Type IV-C construction. The Committee proposed a height of 7 stories for I-1, and 6 stories for I-2. No additional height was proposed for Type IV-C construction (IV-C construction heights in floors is equal to the number of floors already allowed for Type IV-HT, 5 stories for I-1, 4 stories for I-2).

For Group M occupancies, the Committee again took a conservative approach, and proposed an equivalent number of stories for Type IV-A construction, as is provided for Type I-B construction (12 stories for both construction types). The proposal for Type IV-B construction is 8 stories which is based on the use of the multiplier of 1.5 with respect to the Type IV-A proposal. A modest increase (from 5 to 6 stories) is proposed for Type IV-C construction due to the higher requirement for structural fire-resistance.

For Group S, while the base code does not differentiate between S-1 and S-2 in Type I-B construction (both 12 stories), the Committee recognized that the base code does provide a difference for Group F (10 stories for F-1, 12 stories for F-2). As explained above, this led the Committee to propose lower heights for F-1, than for F-2. The Committee felt this was appropriate with respect to the hazard differences between F-1 and F-2. Rather than basing our proposal for S occupancies on the same starting point of 12 stories, the Committee decided to simply copy the proposed heights for Group F into the rows for Group S for both IV-A and IV-B construction types. No additional height is proposed for IV-C construction (IV-C proposed at 5 stories for both S-1 and S-2, same as existing Type IV-HT heights).

Background information: The ICC Board approved the establishment of an ad hoc committee for tall wood buildings in December of 2015. The purpose of the ad hoc committee is to explore the science of tall wood buildings and to investigate the feasibility and take action on developing code changes for tall wood buildings. The committee is comprised of a balance of stakeholders with additional opportunities for interested parties to participate in the four Work Groups established by the ad hoc committee, namely: Code; Fire; Standards/Definitions; and Structural. For more information, be sure to visit the ICC website <https://www.iccsafe.org/codes-tech-support/cs/icc-ad-hoc-committee-on-tall-wood-buildings/> (link active and up to date as of 12/27/17). As seen in the "Meeting Minutes and Documents" and "Resource Documents" sections of the committee web page, the ad hoc committee reviewed a substantial amount of information in order to provide technical justification for code proposals.

The ad hoc committee developed proposals for the followings code sections. The committee believes this package of code changes will result in regulations that adequately address the fire and life safety issues of tall mass timber buildings

IBC Code Section	Description
403.3.2	Water supply requirements for fire pumps in high rise buildings of Type IVA and IVB construction.
504.3	Allowable building height (feet) for buildings of Type IVA, IVB and IVC construction. No changes to Type IV HT construction.
504.4	Allowable building height (stories) for buildings of Type IVA, IVB and IVC construction. No changes to Type IV HT.
506.2	Allowable building area for buildings of Type IVA, IVB and IVC construction. No changes to Type IV HT.
508.4.4.1 509.4.1.1 (new)	Requirements for mass timber building elements serving as fire barriers or horizontal assemblies in buildings of Type IVB or IVC construction.
602.4	Type of Construction requirements for new proposed types of construction: Types IVA, IVB and IVC. No changes to Type IV HT construction. Includes definitions for new terms: Mass timber and Noncombustible protection (mass timber). THIS IS THE KEY CODE CHANGE PROPOSAL WHICH OUTLINES THE CONSTRUCTION REQUIREMENTS FOR THE PROPOSED NEW TYPE OF MASS TIMBER BUILDINGS. THE PROPOSAL ALSO ADDRESSES CONCEALED SPACES, ADHESIVE PERFORMANCE AND EXTERIOR WALL PROTECTION.
703.8 (new)	The performance method to determine the increase to the fire resistance rating provided by noncombustible protection applied to the mass timber building element.
703.9 (new)	Requirements for sealants and adhesives to be placed at abutting edges and intersections of mass timber building elements. The reason statement references a Group B proposal to Chapter 17 for special inspection requirements of sealants and adhesives.
718.2.1	Requirements on the use of mass timber building elements used for Fireblocking.
722.7 (new)	Requirements for the fire resistance rating of mass timber elements, including minimum required protection and gypsum board attachment requirements.
3102	Requirements for membrane structures using Type IV HT construction.
3314.7 (new)	New special precautions during construction of buildings of Types IVA, IVB and IVC construction: Standpipes; Water supply for fire department connections; Noncombustible protection required for mass timber elements as construction height increases.
Appendix	Requirements for walls, floors and roofs of Type IV HT construction in buildings located in Fire Districts.
IFC Code Section	Description
701.6	Requirements which stipulate the owner's responsibility to maintain inventory of all required fire resistance rated construction in buildings of Types IVA and IVB construction. This includes an annual inspection and proper repair where necessary.
Proposed changes to be submitted in 2019 Group B	
IBC Chapter 17	Required special inspections of mass timber construction <ul style="list-style-type: none"> • Structural • Sealants and adhesives (see IBC 703.8)
IBC Chapter 23	An update to referenced standard APA PRG 320 Standard for Performance –rated Cross-laminated Timber which is currently undergoing revision to ensure the adequacy of the adhesives under fire conditions.

In addition, fire tests designed to simulate the three new construction types (Types IVA, IVB and IVC) in the ad hoc committee proposals were conducted at the Alcohol Tobacco and Firearms test lab facility. The TWB was involved in the design of the tests, and many members witnessed the test in person or online. The results of the series of 5 fire tests provide additional support for these proposals, and validate the fire performance for each of the types of construction proposed by the committee. The fire tests consisted of one-bedroom apartments on two levels, with both apartments having a corridor leading to a stair. The purpose of the tests was to address the contribution of mass timber to a fire, the performance of connections, the performance of through-penetration fire stops, and to evaluate conditions for responding fire personnel.

To review a summary of the fire tests, please visit:

<http://bit.ly/ATF-firetestreport>

To watch summary videos of the fire tests, which are accelerated to run in 3 ½ minutes, please visit:

<http://bit.ly/ATF-firetestvideos>

Both of these links were confirmed active on 12/27/17.

Cost Impact

The code change proposal will not increase or decrease the cost of construction .

This section provides information that was not previously set forth in the code, and does not change the requirements of current code, thus there is no cost impact when compared with present requirements.

Internal ID: 846

G81-18

IBC: TABLE 504.4, TABLE 506.2

Proponent: Ed Kullik, representing ICC Building Code Action Committee (bcac@iccsafe.org)

2018 International Building Code

Revise as follows:

TABLE 504.4
ALLOWABLE NUMBER OF STORIES ABOVE GRADE PLANE^a PLANE^{a, b}

OCCUPANCY CLASSIFICATION	TYPE OF CONSTRUCTION									
	SEE FOOTNOTES	TYPE I		TYPE II		TYPE III		TYPE IV	TYPE V	
		A	B	A	B	A	B	HT	A	B
A-1	NS	UL	5	3	2	3	2	3	2	1
	S	UL	6	4	3	4	3	4	3	2
A-2	NS	UL	11	3	2	3	2	3	2	1
	S	UL	12	4	3	4	3	4	3	2
A-3	NS	UL	11	3	2	3	2	3	2	1
	S	UL	12	4	3	4	3	4	3	2
A-4	NS	UL	11	3	2	3	2	3	2	1
	S	UL	12	4	3	4	3	4	3	2
A-5	NS	UL	UL	UL	UL	UL	UL	UL	UL	UL
	S	UL	UL	UL	UL	UL	UL	UL	UL	UL
B	NS	UL	11	5	3	5	3	5	3	2
	S	UL	12	6	4	6	4	6	4	3
E	NS	UL	5	3	2	3	2	3	1	1
	S	UL	6	4	3	4	3	4	2	2
F-1	NS	UL	11	4	2	3	2	4	2	1
	S	UL	12	5	3	4	3	5	3	2
F-2	NS	UL	11	5	3	4	3	5	3	2
	S	UL	12	6	4	5	4	6	4	3
H-1	NS ^{c, d}	1	1	1	1	1	1	1	1	NP
	S									
H-2	NS ^{c, d}	UL	3	2	1	2	1	2	1	1
	S									
H-3	NS ^{c, d}	UL	6	4	2	4	2	4	2	1
	S									
H-4	NS ^{c, d}	UL	7	5	3	5	3	5	3	2
	S	UL	8	6	4	6	4	6	4	3
H-5	NS ^{c, d}	4	4	3	3	3	3	3	3	2
	S									
I-1 Condition 1	NS ^{d, e}	UL	9	4	3	4	3	4	3	2
	S	UL	10	5	4	5	4	5	4	3
I-1 Condition 2	NS ^{d, e}	UL	9	4	3	4	3	4	3	2
	S	UL	10	5						
I-2	NS ^{d, f}	UL	4	2	1	1	NP	1	1	NP
	S	UL	5	3						
I-3	NS ^{d, e}	UL	4	2	1	2	1	2	2	1
	S	UL	5	3	2	3	2	3	3	2
I-4	NS ^{d, g}	UL	5	3	2	3	2	3	1	1
	S	UL	6	4	3	4	3	4	2	2
M	NS	UL	11	4	2	4	2	4	3	1
	S	UL	12	5	3	5	3	5	4	2
R-1 ^h	NS ^d	UL	11	4	4	4	4	4	3	2
	S	UL	12	5	5	5	5	5	4	3
R-2 ^h	NS ^d	UL	11	4	4	4	4	4	3	2

	S	UL	12	5	5	5	5	5	4	3
R-3 ^h	NS ^d	UL	11	4	4	4	4	4	3	3
	S	UL	12	5	5	5	5	5	4	4
R-4 ^h	NS ^d	UL	11	4	4	4	4	4	3	2
	S	UL	12	5	5	5	5	5	4	3
S-1	NS	UL	11	4	2	3	2	4	3	1
	S	UL	12	5	3	4	3	5	4	2
S-2	NS	UL	11	5	3	4	3	4 ₅	4	2
	S	UL	12	6	4	5	4	5 ₆	5	3
U	NS	UL	5	4	2	3	2	4	2	1
	S	UL	6	5	3	4	3	5	3	2

UL = Unlimited; NP = Not Permitted; NS = Buildings not equipped throughout with an automatic sprinkler system; S = Buildings equipped throughout with an automatic sprinkler system installed in accordance with Section 903.3.1.1; S13R = Buildings equipped throughout with an automatic sprinkler system installed in accordance with Section 903.3.1.2; S13D = Buildings equipped throughout with an automatic sprinkler system installed in accordance with Section 903.3.1.3.

- a. See Chapters 4 and 5 for specific exceptions to the allowable height in this chapter.
- b. See Section 903.2 for the minimum thresholds for protection by an automatic sprinkler system for specific occupancies.
- c. New Group H occupancies are required to be protected by an automatic sprinkler system in accordance with Section 903.2.5.
- d. The NS value is only for use in evaluation of existing building height in accordance with the International Existing Building Code.
- e. New Group I-1 and I-3 occupancies are required to be protected by an automatic sprinkler system in accordance with Section 903.2.6. For new Group I-1 occupancies, Condition 1, see Exception 1 of Section 903.2.6.
- f. New and existing Group I-2 occupancies are required to be protected by an automatic sprinkler system in accordance with Section 903.2.6 and 1103.5 of the International Fire Code.
- g. For new Group I-4 occupancies, see Exceptions 2 and 3 of Section 903.2.6.
- h. New Group R occupancies are required to be protected by an automatic sprinkler system in accordance with Section 903.2.8.

TABLE 506.2
ALLOWABLE AREA FACTOR (At = NS, S1, S13R, S13D or SM, as applicable) IN SQUARE FEET^a FEET^{a, b}

OCCUPANCY CLASSIFICATION	SEE FOOTNOTES	TYPE OF CONSTRUCTION							
		TYPE I		TYPE II		TYPE III		TYPE IV	TYPE V
		A	B	A	B	A	B	HT	A
A-1	NS	UL	UL	15,500	8,500	14,000	8,500	15,000	11,500
	S1	UL	UL	62,000	34,000	56,000	34,000	60,000	46,000
	SM	UL	UL	46,500	25,500	42,000	25,500	45,000	34,500
A-2	NS	UL	UL	15,500	9,500	14,000	9,500	15,000	11,500
	S1	UL	UL	62,000	38,000	56,000	38,000	60,000	46,000
	SM	UL	UL	46,500	28,500	42,000	28,500	45,000	34,500
A-3	NS	UL	UL	15,500	9,500	14,000	9,500	15,000	11,500
	S1	UL	UL	62,000	38,000	56,000	38,000	60,000	46,000
	SM	UL	UL	46,500	28,500	42,000	28,500	45,000	34,500
A-4	NS	UL	UL	15,500	9,500	14,000	9,500	15,000	11,500
	S1	UL	UL	62,000	38,000	56,000	38,000	60,000	46,000
	SM	UL	UL	46,500	28,500	42,000	28,500	45,000	34,500
A-5	NS	UL	UL	UL	UL	UL	UL	UL	UL
	S1								
	SM								
B	NS	UL	UL	37,500	23,000	28,500	19,000	36,000	18,000
	S1	UL	UL	150,000	92,000	114,000	76,000	144,000	72,000
	SM	UL	UL	112,500	69,000	85,500	57,000	108,000	54,000
E	NS	UL	UL	26,500	14,500	23,500	14,500	25,500	18,500
	S1	UL	UL	106,000	58,000	94,000	58,000	102,000	74,000
	SM	UL	UL	79,500	43,500	70,500	43,500	76,500	55,500
F-1	NS	UL	UL	25,000	15,500	19,000	12,000	33,500	14,000
	S1	UL	UL	100,000	62,000	76,000	48,000	134,000	56,000
	SM	UL	UL	75,000	46,500	57,000	36,000	100,500	42,000
F-2	NS	UL	UL	37,500	23,000	28,500	18,000	50,500	21,000
	S1	UL	UL	150,000	92,000	114,000	72,000	202,000	84,000
	SM	UL	UL	112,500	69,000	85,500	54,000	151,500	63,000
H-1	NS ^c	21,000	16,500	11,000	7,000	9,500	7,000	10,500	7,500
	S1								
H-2	NS ^c	21,000	16,500	11,000	7,000	9,500	7,000	10,500	7,500
	S1								
	SM								
H-3	NS ^c	UL	60,000	26,500	14,000	17,500	13,000	25,500	10,000
	S1								
	SM								
H-4	NS ^{c, d}	UL	UL	37,500	17,500	28,500	17,500	36,000	18,000
	S1	UL	UL	150,000	70,000	114,000	70,000	144,000	72,000
	SM	UL	UL	112,500	52,500	85,500	52,500	108,000	54,000
H-5	NS ^{c, d}	UL	UL	37,500	23,000	28,500	19,000	36,000	18,000
	S1	UL	UL	150,000	92,000	114,000	76,000	144,000	72,000
	SM	UL	UL	112,500	69,000	85,500	57,000	108,000	54,000
I-1	NS ^{d, e}	UL	55,000	19,000	10,000	16,500	10,000	18,000	10,500
	S1	UL	220,000	76,000	40,000	66,000	40,000	72,000	42,000

	SM	UL	165,000	57,000	30,000	49,500	30,000	54,000	31,500
I-2	NS ^{d, f}	UL	UL	15,000	11,000	12,000	NP	12,000	9,500
	S1	UL	UL	60,000	44,000	48,000	NP	48,000	38,000
	SM	UL	UL	45,000	33,000	36,000	NP	36,000	28,500
I-3	NS ^{d, e}	UL	UL	15,000	10,000	10,500	7,500	12,000	7,500
	S1	UL	UL	45,000 60,000	40,000	42,000	30,000	48,000	30,000
	SM	UL	UL	45,000	30,000	31,500	22,500	36,000	22,500
I-4	NS ^{d, g}	UL	60,500	26,500	13,000	23,500	13,000	25,500	18,500
	S1	UL	121,000	106,000	52,000	94,000	52,000	102,000	74,000
	SM	UL	181,500	79,500	39,000	70,500	39,000	76,500	55,500
M	NS	UL	UL	21,500	12,500	18,500	12,500	20,500	14,000
	S1	UL	UL	86,000	50,000	74,000	50,000	82,000	56,000
	SM	UL	UL	64,500	37,500	55,500	37,500	61,500	42,000
R-1 ^h	NS ^d	UL	UL	24,000	16,000	24,000	16,000	20,500	12,000
	S13R								
	SM	UL	UL	72,000	48,000	72,000	48,000	61,500	36,000
R-2 ^h	NS ^d	UL	UL	24,000	16,000	24,000	16,000	20,500	12,000
	S13R								
	SM	UL	UL	72,000	48,000	72,000	48,000	61,500	36,000
R-3 ^h	NS ^d	UL	UL	UL	UL	UL	UL	UL	UL
	S1								
R-4 ^h	NS ^d	UL	UL	24,000	16,000	24,000	16,000	20,500	12,000
	S1	UL	UL	96,000	64,000	96,000	64,000	82,000	48,000
S-1	SM	UL	UL	72,000	48,000	72,000	48,000	61,500	36,000
	NS	UL	48,000	26,000	17,500	26,000	17,500	25,500	14,000
	S1	UL	192,000	104,000	70,000	104,000	70,000	102,000	56,000
S-2	SM	UL	144,000	78,000	52,500	78,000	52,500	76,500	42,000
	NS	UL	79,000	39,000	26,000	39,000	26,000	38,500	21,000
	S1	UL	316,000	156,000	104,000	156,000	104,000	154,000	84,000
U	SM	UL	237,000	117,000	78,000	117,000	78,000	115,500	63,000
	NS ⁱ	UL	35,500	19,000	8,500	14,000	8,500	18,000	9,000
	S1	UL	142,000	76,000	34,000	56,000	34,000	72,000	36,000
	SM	UL	106,500	57,000	25,500	42,000	25,500	54,000	27,000

For SI: 1 square foot = 0.0929 m².

UL = Unlimited; NP = Not Permitted; NS = Buildings not equipped throughout with an automatic sprinkler system; S1 = Buildings a maximum of one story above grade plane equipped throughout with an automatic sprinkler system installed in accordance with Section 903.3.1.1; SM = Buildings two or more stories above grade plane equipped sprinkler system installed in accordance with Section 903.3.1.2; S13D = Buildings equipped throughout with an automatic sprinkler system installed in accordance with Section 903.3.1.3.

- a. See Chapters 4 and 5 for specific exceptions to the allowable height in this chapter.
- b. See Section 903.2 for the minimum thresholds for protection by an automatic sprinkler system for specific occupancies.
- c. New Group H occupancies are required to be protected by an automatic sprinkler system in accordance with Section 903.2.5.
- d. The NS value is only for use in evaluation of existing building area in accordance with the International Existing Building Code.
- e. New Group I-1 and I-3 occupancies are required to be protected by an automatic sprinkler system in accordance with Section 903.2.6. For new Group I-1 occupancies, Condition 1, see Exception 1 of Section 903.2.6.
- f. New and existing Group I-2 occupancies are required to be protected by an automatic sprinkler system in accordance with Section 903.2.6 and Section 1103.5 of the International Fire Code.
- g. New Group I-4 occupancies see Exceptions 2 and 3 of Section 903.2.6.
- h. New Group R occupancies are required to be protected by an automatic sprinkler system in accordance with Section 903.2.8.
- i. The maximum allowable area for a single-story nonsprinklered Group U greenhouse is permitted to be 9,000 square feet, or the allowable area shall be permitted to comply with Table C102.1 of Appendix C.

Reason:

Tables 504.4 and 506.2 were introduced into the code by code change G101-12, submitted by the ICC Building Code Action Committee (BCAC), as part of a substantial overhaul of the height and area provisions. The new tables replaced Table 503. It was not the intent of G101-12 to make any changes to allowable building height or area rendered by these provisions, compared to what was previously allowed. This proposed change corrects two tabular value errors that went undetected in the original code change until after the completion of the 2012 cycle: the tabular story height numbers for Type IV Group S-2, and the allowable area factor for Type II-A Group I-3. The following is taken from the 2012 edition of the IBC which shows the height and areas for S-2 and I-3 as shown in Table 503, from which Tables 504.4 and 506.2 were derived.

This proposal is submitted by the ICC Building Code Action Committee (BCAC). BCAC was established by the ICC Board of Directors in July 2011 to pursue opportunities to improve and enhance assigned International Codes or portions thereof. In 2017 the BCAC has held 3 open meetings. In addition, there were numerous Working Group meetings and conference calls for the current code development cycle, which included members of the committee as well as any interested party to discuss and debate the proposed changes. Related documentation and reports are posted on the BCAC website at: <https://www.iccsafe.org/codes-tech-support/codes/code-development-process/building-code-action-committee-bcac>.

Cost Impact

The code change proposal will decrease the cost of construction .

This is a correction to the height and area tables based upon an error in previous code change submittals. The proposal will restore these values to the correct values. Will actually decrease the cost of construction compared to the current code because more lenient limitations are imposed.

Internal ID: 1548

G82-18

IBC: 505.2.1

Proponent: Todd Snider, West Coast Code Consultants (WC3), representing Self (Todd@KimballEng.com)

2018 International Building Code

Revise as follows:

505.2.1 Area limitation. The aggregate area of a *mezzanine* or *mezzanines* within a room shall be not greater than one-third of the floor area of ~~that a single room or space in which they are located, from which that mezzanine is accessed.~~ The enclosed portion of a room shall not be included in a determination of the floor area of the room in which the *mezzanine* is located. In determining the allowable *mezzanine* area, the area of the *mezzanine* shall not be included in the floor area of the room.

Exceptions:

1. The aggregate area of *mezzanines* in buildings and structures of Type I or II construction for special industrial occupancies in accordance with Section 503.1.1 shall be not greater than two-thirds of the floor area of the room.
2. The aggregate area of *mezzanines* in buildings and structures of Type I or II construction shall be not greater than one-half of the floor area of the room in buildings and structures equipped throughout with an *approved automatic sprinkler system* in accordance with Section 903.3.1.1 and an *approved emergency voice/alarm communication system* in accordance with Section 907.5.2.2.
3. The aggregate area of a *mezzanine* within a *dwelling unit* that is located in a building equipped throughout with an *approved automatic sprinkler system* in accordance with Section 903.3.1.1 or 903.3.1.2 shall not be greater than one-half of the floor area of the room, provided that:
 - 3.1. Except for enclosed closets and bathrooms, the *mezzanine* shall be open to the room in which such *mezzanine* is located;
 - 3.2. The opening to the room shall be unobstructed except for walls not more than 42 inches (1067 mm) in height, columns and posts; and
 - 3.3. Exceptions to Section 505.2.3 shall not be permitted.

Reason:

Proposed revision to add clarification to the room or space in which a mezzanine is located. The intent of mezzanines is that they are intended to be open to a room and it is no more hazardous to be located within the mezzanine of a room or space than to be in that room or space. Often times, however, this option is being used for mezzanines which are said to be located in one room the only egress is through a different room. For example in grocery floors they will use 1/3 the area of the sales floor but the access to the mezzanine is through the stock room.

Cost Impact

The code change proposal will not increase or decrease the cost of construction .

The cost of this clarification is impossible to value. It will, at times, change design or layout that could increase or decrease cost.

Internal ID: 1175

G83-18

IBC: 505.2.3

Proponent: Ronald Clements Jr, Chesterfield County Building Inspection Department, representing Chesterfield County Building Inspection Department (clementsro@chesterfield.gov); Lee Kranz, City of Bellevue, WA Representing the Washington Association of Building Officials Technical Code Development Committee (lkranz@bellevuewa.gov); Keith Flanders, representing self (kflanders@cosentini.com); Todd Snider (Todd@KimballEng.com)

2018 International Building Code

Revise as follows:

505.2.3 Openness. A *mezzanine* shall be open and unobstructed to the room in which such *mezzanine* is located except for walls not more than 42 inches (1067 mm) in height, columns and posts.

Exceptions:

1. Mezzanines or portions thereof are not required to be open to the room in which the *mezzanines* are located, provided that the *occupant load* of the aggregate area of the enclosed space is not greater than 10.
2. A *mezzanine* having two or more exits or access to exits is not required to be open to the room in which the *mezzanine* is located.
3. Mezzanines or portions thereof are not required to be open to the room in which the *mezzanines* are located, provided that the aggregate floor area of the enclosed space is not greater than 10 percent of the *mezzanine* area.
4. In industrial facilities, *mezzanines* used for control equipment are permitted to be glazed on all sides.
5. ~~In occupancies other than Groups II and I, which are no more than two stories above grade plane and equipped throughout with an automatic sprinkler system in accordance with Section 903.3.1.1, a *mezzanine* having two or more exits or access to exits shall not be required to be open to the room in which the *mezzanine* is located.~~

Reason:

Ron Clements

Per exception 2 to section 505.2.3, which was revised in the 2015 IBC, a mezzanine is not required to be open to the room in which the mezzanine is located if the mezzanine has two exits or access to two exits. Exception two has no qualifiers; therefore, exception two would always apply in the conditions listed for exception five. Since exception two will always apply without the sprinkler, story or occupancy group qualifiers required for use of exception five, exception five is no longer needed.

Keith Flanders

Exception 5 is no longer necessary as exception 2 was modified in previous cycles and is less restrictive. Per exception 2, a mezzanine having two or more exits or access to exits is not required to be open to the room in which the mezzanine is located. This is the same as the second part of exception 5, without the occupancy limitations or requirements for a sprinkler system.

Lee Kranz

Exception #5 of Section 505.2.3 is not needed because it is more restrictive and exception #2 in this section will govern in every case.

Todd Snider

Proposed revision to remove Exception 5, because it is redundant to Exception 2.

Cost Impact

The code change proposal will not increase or decrease the cost of construction .

There is no cost impact because the exception five that is proposed for deletion is obsolete.

Internal ID: 678

G84-18

IBC: TABLE 506.2

Proponent: Stephen DiGiovanni, representing ICC Ad Hoc Committee on Tall Wood Buildings (TWB) (TWB@iccsafe.org)

2018 International Building Code

Revise as follows:

TABLE 506.2
ALLOWABLE AREA FACTOR (A_t = NS, S1, S13R, S13D or SM, as applicable) IN SQUARE FEET ^{a, b}

OCCUPANCY CLASSIFICATION	SEE FOOTNOTES	TYPE OF CONSTRUCTION							
		TYPE I		TYPE II		TYPE III		TYPE IV	
		A	B	A	B	A	B	A	B
A-1	NS	UL	UL	15,500	8,500	14,000	8,500	<u>45,000</u>	<u>30,000</u>
	S1	UL	UL	62,000	34,000	56,000	34,000	<u>180,000</u>	<u>120,000</u>
	SM	UL	UL	46,500	25,500	42,000	25,500	<u>135,000</u>	<u>90,000</u>
A-2	NS	UL	UL	15,500	9,500	14,000	9,500	<u>45,000</u>	<u>30,000</u>
	S1	UL	UL	62,000	38,000	56,000	38,000	<u>180,000</u>	<u>120,000</u>
	SM	UL	UL	46,500	28,500	42,000	28,500	<u>135,000</u>	<u>90,000</u>
A-3	NS	UL	UL	15,500	9,500	14,000	9,500	<u>45,000</u>	<u>30,000</u>
	S1	UL	UL	62,000	38,000	56,000	38,000	<u>180,000</u>	<u>120,000</u>
	SM	UL	UL	46,500	28,500	42,000	28,500	<u>135,000</u>	<u>90,000</u>
A-4	NS	UL	UL	15,500	9,500	14,000	9,500	<u>45,000</u>	<u>30,000</u>
	S1	UL	UL	62,000	38,000	56,000	38,000	<u>180,000</u>	<u>120,000</u>
	SM	UL	UL	46,500	28,500	42,000	28,500	<u>135,000</u>	<u>90,000</u>
A-5	NS	UL	UL	UL	UL	UL	UL	<u>UL</u>	<u>UL</u>
	S1								
	SM								
B	NS	UL	UL	37,500	23,000	28,500	19,000	<u>108,000</u>	<u>72,000</u>
	S1	UL	UL	150,000	92,000	114,000	76,000	<u>432,000</u>	<u>288,000</u>
	SM	UL	UL	112,500	69,000	85,500	57,000	<u>324,000</u>	<u>216,000</u>
E	NS	UL	UL	26,500	14,500	23,500	14,500	<u>76,500</u>	<u>51,000</u>
	S1	UL	UL	106,000	58,000	94,000	58,000	<u>306,000</u>	<u>204,000</u>
	SM	UL	UL	79,500	43,500	70,500	43,500	<u>229,500</u>	<u>153,000</u>
F-1	NS	UL	UL	25,000	15,500	19,000	12,000	<u>100,500</u>	<u>67,000</u>
	S1	UL	UL	100,000	62,000	76,000	48,000	<u>402,000</u>	<u>268,000</u>
	SM	UL	UL	75,000	46,500	57,000	36,000	<u>301,500</u>	<u>201,000</u>
F-2	NS	UL	UL	37,500	23,000	28,500	18,000	<u>151,500</u>	<u>101,000</u>
	S1	UL	UL	150,000	92,000	114,000	72,000	<u>606,000</u>	<u>404,000</u>
	SM	UL	UL	112,500	69,000	85,500	54,000	<u>454,500</u>	<u>303,000</u>
H-1	NS ^c	21,000	16,500	11,000	7,000	9,500	7,000	<u>10,500</u>	<u>10,500</u>
	S1								
H-2	NS ^c	21,000	16,500	11,000	7,000	9,500	7,000	<u>10,500</u>	<u>10,500</u>
	S1								
	SM								
H-3	NS ^c	UL	60,000	26,500	14,000	17,500	13,000	<u>25,500</u>	<u>25,500</u>
	S1								
	SM								
H-4	NS ^{c, d}	UL	UL	37,500	17,500	28,500	17,500	<u>72,000</u>	<u>54,000</u>
	S1	UL	UL	150,000	70,000	114,000	70,000	<u>288,000</u>	<u>216,000</u>
	SM	UL	UL	112,500	52,500	85,500	52,500	<u>216,000</u>	<u>162,000</u>
H-5	NS ^{c, d}	UL	UL	37,500	23,000	28,500	19,000	<u>72,000</u>	<u>54,000</u>
	S1	UL	UL	150,000	92,000	114,000	76,000	<u>288,000</u>	<u>216,000</u>
	SM	UL	UL	112,500	69,000	85,500	57,000	<u>216,000</u>	<u>162,000</u>
I-1	NS ^{d, e}	UL	55,000	19,000	10,000	16,500	10,000	<u>54,000</u>	<u>36,000</u>
	S1	UL	220,000	76,000	40,000	66,000	40,000	<u>216,000</u>	<u>144,000</u>

	SM	UL	165,000	57,000	30,000	49,500	30,000	<u>162,000</u>	<u>108,000</u>
I-2	NS ^{d, f}	UL	UL	15,000	11,000	12,000	NP	<u>36,000</u>	<u>24,000</u>
	S1	UL	UL	60,000	44,000	48,000	NP	<u>144,000</u>	<u>96,000</u>
	SM	UL	UL	45,000	33,000	36,000	NP	<u>108,000</u>	<u>72,000</u>
I-3	NS ^{d, e}	UL	UL	15,000	10,000	10,500	7,500	<u>36,000</u>	<u>24,000</u>
	S1	UL	UL	45,000	40,000	42,000	30,000	<u>144,000</u>	<u>96,000</u>
	SM	UL	UL	45,000	30,000	31,500	22,500	<u>108,000</u>	<u>72,000</u>
I-4	NS ^{d, g}	UL	60,500	26,500	13,000	23,500	13,000	<u>76,500</u>	<u>51,000</u>
	S1	UL	121,000	106,000	52,000	94,000	52,000	<u>306,000</u>	<u>204,000</u>
	SM	UL	181,500	79,500	39,000	70,500	39,000	<u>229,500</u>	<u>153,000</u>
M	NS	UL	UL	21,500	12,500	18,500	12,500	<u>61,500</u>	<u>41,000</u>
	S1	UL	UL	86,000	50,000	74,000	50,000	<u>246,000</u>	<u>164,000</u>
	SM	UL	UL	64,500	37,500	55,500	37,500	<u>184,500</u>	<u>123,000</u>
R-1 ^h	NS ^d	UL	UL	24,000	16,000	24,000	16,000	<u>61,500</u>	<u>41,000</u>
	S13R								
	S1	UL	UL	96,000	64,000	96,000	64,000	<u>246,000</u>	<u>164,000</u>
	SM	UL	UL	72,000	48,000	72,000	48,000	<u>184,500</u>	<u>123,000</u>
R-2 ^h	NS ^d	UL	UL	24,000	16,000	24,000	16,000	<u>61,500</u>	<u>41,000</u>
	S13R								
	S1	UL	UL	96,000	64,000	96,000	64,000	<u>246,000</u>	<u>164,000</u>
	SM	UL	UL	72,000	48,000	72,000	48,000	<u>184,500</u>	<u>123,000</u>
R-3 ^h	NS ^d	UL	UL	UL	UL	UL	UL	<u>UL</u>	<u>UL</u>
	S13D								
	S13R								
	S1								
	SM								
R-4 ^h	NS ^d	UL	UL	24,000	16,000	24,000	16,000	<u>61,500</u>	<u>41,000</u>
	S13D								
	S13R								
	S1	UL	UL	96,000	64,000	96,000	64,000	<u>246,000</u>	<u>164,000</u>
	SM	UL	UL	72,000	48,000	72,000	48,000	<u>184,500</u>	<u>123,000</u>
S-1	NS	UL	48,000	26,000	17,500	26,000	17,500	<u>76,500</u>	<u>51,000</u>
	S1	UL	192,000	104,000	70,000	104,000	70,000	<u>306,000</u>	<u>204,000</u>
	SM	UL	144,000	78,000	52,500	78,000	52,500	<u>229,500</u>	<u>153,000</u>
S-2	NS	UL	79,000	39,000	26,000	39,000	26,000	<u>115,500</u>	<u>77,000</u>
	S1	UL	316,000	156,000	104,000	156,000	104,000	<u>462,000</u>	<u>308,000</u>
	SM	UL	237,000	117,000	78,000	117,000	78,000	<u>346,500</u>	<u>231,000</u>
U	NS ⁱ	UL	35,500	19,000	8,500	14,000	8,500	<u>54,000</u>	<u>36,000</u>
	S1	UL	142,000	76,000	34,000	56,000	34,000	<u>216,000</u>	<u>144,000</u>
	SM	UL	106,500	57,000	25,500	42,000	25,500	<u>162,000</u>	<u>108,000</u>

For SI: 1 square foot = 0.0929 m².

UL = Unlimited; NP = Not Permitted; NS = Buildings not equipped throughout with an automatic sprinkler system; S1 = Buildings a maximum of one story above grade plane equipped throughout with an automatic sprinkler system installed in accordance with Section 903.3.1.1; SM = Buildings two or more stories above grade plane equipped throughout with an automatic sprinkler system installed in accordance with Section 903.3.1.1; S13R = Buildings equipped throughout with an automatic sprinkler system installed in accordance with Section 903.3.1.2; S13D = Buildings equipped throughout with an automatic sprinkler system installed in accordance with Section 903.3.1.3.

- a. See Chapters 4 and 5 for specific exceptions to the allowable height in this chapter.
- b. See Section 903.2 for the minimum thresholds for protection by an automatic sprinkler system for specific occupancies.
- c. New Group H occupancies are required to be protected by an automatic sprinkler system in accordance with Section 903.2.5.
- d. The NS value is only for use in evaluation of existing building area in accordance with the International Existing Building Code.
- e. New Group I-1 and I-3 occupancies are required to be protected by an automatic sprinkler system in accordance with Section 903.2.6. For new Group I-1 occupancies, Condition 1, see Exception 1 of Section 903.2.6.
- f. New and existing Group I-2 occupancies are required to be protected by an automatic sprinkler system in accordance with Section 903.2.6 and Section 1103.5 of the International Fire Code.
- g. New Group I-4 occupancies see Exceptions 2 and 3 of Section 903.2.6.
- h. New Group R occupancies are required to be protected by an automatic sprinkler system in accordance with Section 903.2.8.
- i. The maximum allowable area for a single-story nonsprinklered Group U greenhouse is permitted to be 9,000 square feet, or the allowable area shall be permitted to comply with Table C102.1 of Appendix C.

Reason:

The Ad Hoc Committee on Tall Wood Buildings (TWB) was created by the ICC Board to explore the science of tall wood buildings and take action on developing code changes for tall wood buildings. The TWB has created several code change proposals with respect to the concept of tall buildings of mass timber and the background information is at the end of this Statement. Within the statement are important links to information, including documents and videos, used in the deliberations which resulted in these proposals.

The TWB and its various WGs held meetings, studied issues and sought input from various expert sources around the world. The TWB has posted those documents and input on its website for interested parties to follow its progress and to allow those parties to, in turn, provide input to the TWB.

At its first meeting, the TWB discussed a number of performance objectives to be met with the proposed criteria for tall wood buildings:

No collapse under reasonable scenarios of complete burn-out of fuel without automatic sprinkler protection being considered.

No unusually high radiation exposure from the subject building to adjoining properties to present a risk of ignition under reasonably severe fire scenarios.

No unusual response from typical radiation exposure from adjacent properties to present a risk of ignition of the subject building under reasonably severe fire scenarios.

No unusual fire department access issues.

Egress systems designed to protect building occupants during the design escape time, plus a factor of safety.

Highly reliable fire suppression systems to reduce the risk of failure during reasonably expected fire scenarios. The degree of reliability should be proportional to evacuation time (height) and the risk of collapse.

The comprehensive package of proposals from the TWB meet these performance objectives.

Allowable Area

In addressing this topic, it was necessary to develop height and area criteria to address each new type of construction being proposed. Relying upon each new type of construction proposed for tall wood buildings (Types IV-A, IV-B and IV-C), the committee examined each type of construction for its safety and efficacy with regard to each occupancy type. This proposal on allowable areas should be considered as a companion proposal to the height proposals. The three proposals were developed with regard to one another as well as with regard to the new types of construction.

The TWB also determined that fire testing was necessary to validate these concepts. At its first meeting, members discussed the nature and intention of fire testing so as to ensure meaningful results for the TWB and, more specifically, for the fire service. Subsequently a test plan was developed. The fire tests consisted of one-bedroom apartments on two levels, with both apartments having a corridor leading to a stairway. The purpose of the tests was to address the contribution of mass timber to a fire, the performance of connections, the performance of joints, and to evaluate conditions for responding fire personnel. The Fire WG then refined the test plan, which was implemented with a series of five full-scale, multiple-story building tests at the Alcohol, Tobacco and Firearms (ATF) laboratories in Beltsville, MD. The results of those tests, as well as testing conducted by others, helped the Committee form the basis upon which the Codes WG developed its code change proposals. This code change proposal is one of those developed by the Codes WG and adopted by the TWB.

To review a summary of the fire tests, please visit:

<http://bit.ly/ATF-firetestreport>

To watch summary videos of the fire tests, which are accelerated to run in 3-1/2 minutes each, please visit: <http://bit.ly/ATF-firetestvideos>.

Both of these links were confirmed active on 12/27/17.

Each proposed new type of construction was examined for its fire safety characteristics and compared to the existing, long-standing type of construction known as Heavy Timber. The committee found that it was reasonable to develop a multiplier which could be applied to the traditional HT areas. This was done for each new type of construction. Thus, the proposed new Type IV-C was 1.25 times the HT allowable area, IV-B was 2.00 times the HT allowable area and IV-A was 3.00 times the HT allowable area.

These multipliers were examined in terms of relative performance compared to traditional HT. They were reexamined on a case-by-case basis based upon relative hazard and occupancy classification. Some hazards were perceived to be greater and, thus, areas were adjusted downward to reflect the hazard. Other situations were similarly considered. For example, Hazardous and Institutional occupancies do not fully follow the multiplier method, as most areas for those occupancies were reduced from what the multiplier method would suggest.

Also, the committee reconsidered this proposal with respect to the companion height proposal. This review was to be sure that allowable areas were commensurate with the risk posed by being allowed on some particular story or at some height above grade plane.

Background information: The ICC Board approved the establishment of an ad hoc committee for tall wood buildings in December of 2015. The purpose of the ad hoc committee is to explore the science of tall wood buildings and to investigate the feasibility and take action on developing code changes for tall wood buildings. The committee is comprised of a balance of stakeholders with additional opportunities for interested parties to participate in the four Work Groups established by the ad hoc committee, namely: Code; Fire; Standards/Definitions; and Structural. For more information, be sure to visit the ICC website <https://www.iccsafe.org/codes-tech-support/cs/icc-ad-hoc-committee-on-tall-wood-buildings/> (link active and up to date as of 12/27/17). As seen in the "Meeting Minutes and Documents" and "Resource Documents" sections of the committee web page, the ad hoc committee reviewed a substantial amount of information in order to provide technical justification for code proposals.

The ad hoc committee developed proposals for the followings code sections. The committee believes this package of code changes will result in regulations that adequately address the fire and life safety issues of tall mass timber buildings.

IBC Code Section	Description
403.3.2	Water supply requirements for fire pumps in high rise buildings of Type IVA and IVB construction.
504.3	Allowable building height (feet) for buildings of Type IVA, IVB and IVC construction. No changes to Type IV HT construction.
504.4	Allowable building height (stories) for buildings of Type IVA, IVB and IVC construction. No changes to Type IV HT.
506.2	Allowable building area for buildings of Type IVA, IVB and IVC construction. No changes to Type IV HT.
508.4.4.1 509.4.1.1 (new)	Requirements for mass timber building elements serving as fire barriers or horizontal assemblies in buildings of Type IVB or IVC construction.
602.4	Type of Construction requirements for new proposed types of construction: Types IVA, IVB and IVC. No changes to Type IV HT construction. Includes definitions for new terms: Mass timber and Noncombustible protection (mass timber). THIS IS THE KEY CODE CHANGE PROPOSAL WHICH OUTLINES THE CONSTRUCTION REQUIREMENTS FOR THE PROPOSED NEW TYPE OF MASS TIMBER BUILDINGS. THE PROPOSAL ALSO ADDRESSES CONCEALED SPACES, ADHESIVE PERFORMANCE AND EXTERIOR WALL PROTECTION.
703.8 (new)	The performance method to determine the increase to the fire resistance rating provided by noncombustible protection applied to the mass timber building element.
703.9 (new)	Requirements for sealants and adhesives to be placed at abutting edges and intersections of mass timber building elements. The reason statement references a Group B proposal to Chapter 17 for special inspection requirements of sealants and adhesives.
718.2.1	Requirements on the use of mass timber building elements used for Fireblocking.
722.7 (new)	Requirements for the fire resistance rating of mass timber elements, including minimum required protection and gypsum board attachment requirements.
3102	Requirements for membrane structures using Type IV HT construction.
3314.7 (new)	New special precautions during construction of buildings of Types IVA, IVB and IVC construction: Standpipes; Water supply for fire department connections; Noncombustible protection required for mass timber elements as construction height increases.
Appendix	Requirements for walls, floors and roofs of Type IV HT construction in buildings located in Fire Districts.
IFC Code Section	Description
701.6	Requirements which stipulate the owner's responsibility to maintain inventory of all required fire resistance rated construction in buildings of Types IVA and IVB construction. This includes an annual inspection and proper repair where necessary.
Proposed changes to be submitted in 2019 Group B	
IBC Chapter 17	Required special inspections of mass timber construction <ul style="list-style-type: none"> • Structural • Sealants and adhesives (see IBC 703.8)
IBC Chapter 23	An update to referenced standard APA PRG 320 Standard for Performance –rated Cross-laminated Timber which is currently undergoing revision to ensure the adequacy of the adhesives under fire conditions.

In addition, fire tests designed to simulate the three new construction types (Types IVA, IVB and IVC) in the ad hoc committee proposals were conducted at the Alcohol Tobacco and Firearms test lab facility. The TWB was involved in the design of the tests, and many members witnessed the test in person or online. The results of the series of 5 fire tests provide additional support for these proposals, and validate the fire performance for each of the types of construction proposed by the committee. The fire tests consisted of one-bedroom apartments on two levels, with both apartments having a corridor leading to a stair. The purpose of the tests was to address the contribution of mass timber to a fire, the performance of connections, the performance of through-penetration fire stops, and to evaluate conditions for responding fire personnel.

To review a summary of the fire tests, please visit:

<http://bit.ly/ATF-firetestreport>

To watch summary videos of the fire tests, which are accelerated to run in 3 ½ minutes, please visit:

<http://bit.ly/ATF-firetestvideos>

Both of these links were confirmed active on 12/27/17.

Cost Impact

The code change proposal will not increase or decrease the cost of construction .

This section provides information that was not previously set forth in the code, and does not change the requirements of current code, thus there is no cost impact when compared with present requirements.

Internal ID: 849

G85-18

IBC: 506.2.1, 506.2.3, 506.2.2, 506.2.4

Proponent: David Collins, representing The American Institute of Architects (dcollins@preview-group.com)

2018 International Building Code

Revise as follows:

506.2.1 Single-occupancy buildings. ~~The allowable area of each story of a single-occupancy building with no more than one story above grade plane shall be determined in accordance with Equation 5-1:~~

where:

A_a = Allowable area (square feet).

A_t = Tabular allowable area factor (NS, S1, S13R or S13D value, as applicable) in accordance with Table 506.2.

NS = Tabular allowable area factor in accordance with Table 506.2 for nonsprinklered building (regardless of whether the building is sprinklered).

I_f = Area factor increase due to frontage (percent) as calculated in accordance with Section 506.3.

The allowable area per story of a single-occupancy building with a maximum of three stories above grade shall be determined by Equation 5-1. The allowable area per story of a single-occupancy building more than three stories above grade plane shall be determined in accordance with Equation 5-2:

$$A_a = [A_t + (NS \times I_f)] \times S_a \quad \text{(Equation 5-2)}$$

where:

A_a = Allowable area (square feet).

A_t = Tabular allowable area factor (NS, S13R, S13D or SM value, as applicable) in accordance with Table 506.2.

NS = Tabular allowable area factor in accordance with Table 506.2 for a nonsprinklered building (regardless of whether the building is sprinklered).

I_f = Area factor increase due to frontage (percent) as calculated in accordance with Section 506.3.

S_a = 3 where the actual number of stories above grade plane, exceeds three, or

S_a = 4 where the building is equipped throughout with an automatic sprinkler system installed in accordance with Section 903.3.1.2.

The actual area of any individual floor shall not exceed the allowable area per Equation 5-1.

Delete without substitution:

506.2.3 Single-occupancy, multistory buildings. ~~The allowable area of a single-occupancy building with more than one story above grade plane shall be determined in accordance with Equation 5-2:~~

$$A_a = [A_t + (NS \times I_f)] \times S_a \quad \text{(Equation 5-2)}$$

where:

A_a = Allowable area (square feet):

A_t = Tabular allowable area factor (NS, S13R, S13D or SM value, as applicable) in accordance with Table 506.2.

NS = Tabular allowable area factor in accordance with Table 506.2 for a nonsprinklered building (regardless of whether the building is sprinklered).

I_f = Area factor increase due to frontage (percent) as calculated in accordance with Section 506.3.

S_a = Actual number of building stories above grade plane, not to exceed three. For buildings equipped throughout with an automatic sprinkler system installed in accordance with Section 903.3.1.2, use the actual number of building stories above grade plane, not to exceed four.

No individual story shall exceed the allowable area (A_a) as determined by Equation 5-2 using the value of $S_a = 1$.

Revise as follows:

506.2.2 Mixed-occupancy one-story buildings. The allowable area of a floor of a mixed-occupancy building with not more than one story above grade plane shall be determined in accordance with the applicable provisions of Section 508.1 based on Equation 5-1 for each applicable occupancy Section 508.3.2 for non separated occupancies and 508.4.2 for separated occupancies.

For buildings with more than three stories above grade plane, the total building area shall be such that the aggregate sum of the ratios of the actual area of each story divided by the allowable area of such stories, determined in accordance with Equation 5-3 based on the applicable provisions of Section 508.1, shall not exceed three.

$A_a = [A_t + (NS \times I_f)]$ (Equation 5-3)

where:

A_a = Allowable area (square feet).

A_t = Tabular allowable area factor (NS, S13R, S13D or SM value, as applicable) in accordance with Table 506.2.

NS = Tabular allowable area factor in accordance with Table 506.2 for a nonsprinklered building, regardless of whether the building is sprinklered.

I_f = Area factor increase due to frontage (percent) as calculated in accordance with Section 506.3.

Exception: For buildings designed as separated occupancies under Section 508.4 and equipped throughout with an automatic sprinkler system installed in accordance with Section 903.3.1.2, the total building area shall be such that the aggregate sum of the ratios of the actual area of each story divided by the allowable area of such stories determined in accordance with Equation 5-3 based on the applicable provisions of Section 508.1, shall not exceed four.

Delete without substitution:

506.2.4 Mixed-occupancy, multistory buildings. Each story of a mixed-occupancy building with more than one story above grade plane shall individually comply with the applicable requirements of Section 508.1. For buildings with more than three stories above grade plane, the total building area shall be such that the aggregate sum of the ratios of the actual area of each story divided by the allowable area of such stories, determined in accordance with Equation 5-3 based on the applicable provisions of Section 508.1, shall not exceed three.

-

{Equation 5-3}

where:

A_a = Allowable area (square feet).

A_t = Tabular allowable area factor (NS, S13R, S13D or SM value, as applicable) in accordance with Table 506.2.

NS = Tabular allowable area factor in accordance with Table 506.2 for a nonsprinklered building (regardless of whether the building is sprinklered).

I_f = Area factor increase due to frontage (percent) as calculated in accordance with Section 506.3.

Exception: For buildings designed as separated occupancies under Section 508.4 and equipped throughout with an automatic sprinkler system installed in accordance with Section 903.3.1.2, the total building area shall be such that the aggregate sum of the ratios of the actual area of each story divided by the allowable area of such stories determined in accordance with Equation 5-3 based on the applicable

Reason:

Several changes have been made to simplify the process of determining the maximum area of buildings since the 2012 edition of the IBC. However, the provisions for how to address the actual calculation and maximum building areas has not been modified.

This change attempts to follow the lead of those that put together the changes to consolidate the increases for area and height into tables removing the requirement to do the actual calculations for those adjustments. Users of the code often become confused with the provisions for single story buildings and multiple story buildings and then it becomes even more complicated with the application of multiple occupancies, accessory occupancies and incidental occupancies. The new language will remove some of that confusion.

506.2.1 currently only appears to address the area of a one-story building. In reality it affects the allowable area of any story of any building of any height. This change has simplified Section 506.2.1 to indicate that the allowable area of a story must be determined by equation 501. Then the requirements for the allowable area for the building that is over three stories must be calculated to determine the proportional limit.

By eliminating Section 506.2.3 the criteria for the allowable area of a single-occupancy building with more than one story can be found as part. In reality, it only controls single-occupancy buildings that are more than 3 stories. The first,

second and third story of any building is controlled by the allowed area in Equation 5-1. This change has directed the code user to apply Equation 5-2 to single-occupancy buildings with more than three stories. Finally, the language regarding an "individual story" is changed to be the actual area of an individual floor being limited by the area allowed by Equation 5-1 as allowed in 506.2.1.

506.2.2 currently parallels 506.2.1 and indicates that it only limits the allowable area of a one-story building, when in fact it also covers the allowed area of any story of any building of any height. It also implies that it is limited by Equation 5-1. In reality the requirements of Section 508.3.2 and 508.4.2 set the limits for mixed use unseparated and mixed use separated conditions. This change directs the code user to those sections for mixed-occupancy buildings.

506.2.4 duplicates the requirements for mixed-occupancy buildings but in lieu of going to the specific provisions in 508.1 for mixed-occupancy buildings it simply references 508.1. With the change to 506.2.2, this provision is not necessary as it has already been covered.

Cost Impact

The code change proposal will not increase or decrease the cost of construction .

There is no change or impact from this change because it is simply an editorial reorganization of existing text

Internal ID: 1705

G86-18

IBC: 506.3.2, 506.3.3, 506.3.3 (New), Table 506.3.3 (New)

Proponent: Stephen Thomas, Colorado Code Consulting, LLC, representing Colorado Chapter ICC (stthomas@coloradocode.net)

2018 International Building Code

Revise as follows:

506.3 Frontage increase. Every building shall adjoin or have access to a *public way* to receive an area factor increase based on frontage. Area factor increase shall be determined in accordance with Sections 506.3.1 through 506.3.3.

506.3.1 Minimum percentage of perimeter. To qualify for an area factor increase based on frontage, a building shall have not less than 25 percent of its perimeter on a *public way* or open space. Such open space shall be either on the same lot or dedicated for public use and shall be accessed from a street or approved *fire lane*.

506.3.2 Minimum frontage distance. To qualify for an area factor increase based on frontage, the *public way* or open space adjacent to the building perimeter shall have a minimum distance ~~(W)~~ of 20 feet (6096 mm) measured at right angles from the building face to any of the following:

1. The closest interior lot line.
2. The entire width of a street, alley or public way.
3. The exterior face of an adjacent building on the same property.

~~Where the value of W is greater than 30 feet (9144 mm), a value of 30 feet (9144 mm) shall be used in calculating the building area increase based on frontage, regardless of the actual width of the *public way* or open space. Where the value of W varies along the perimeter of the building, the calculation performed in accordance with Equation 5-5 shall be based on the weighted average calculated in accordance with Equation 5-4.~~

~~Equ5_4.jpg~~

~~(Equation 5-4)~~

~~where:~~

~~W (Width: weighted average) = Calculated width of *public way* or open space (feet).~~

~~L_p = Length of a portion of the exterior perimeter wall.~~

~~w_p = Width (≥ 20 feet) of a *public way* or open space associated with that portion of the exterior perimeter wall.~~

~~F = Building perimeter that fronts on a *public way* or open space having a width of 20 feet (6096 mm) or more.~~

~~**Exception:** Where a building meets the requirements of Section 507, as applicable, except for compliance with the minimum 60-foot (18 288 mm) *public way* or yard requirement, and the value of W is greater than 30 feet (9144 mm), the value of W shall not exceed 60 feet (18 288 mm).~~

~~The frontage increase shall be based on the smallest *public way* or open space that is 20 feet (6096 mm) or greater, and the percentage of building perimeter having a minimum 20 feet (6096 mm) *public way* or open space.~~

506.3.3 Amount of increase. The area factor increase based on frontage shall be determined in accordance with Equation 5-5:

~~$I_f = [F/P - 0.25]W/30$~~

~~$I_f = [F/P - 0.25]W/30$~~

~~(Equation 5-5)~~

~~where:~~

~~I_f = Area factor increase due to frontage.~~

~~F = Building perimeter that fronts on a *public way* or open space having minimum distance of 20 feet (6096 mm).~~

~~P = Perimeter of entire building (feet).~~

~~W = Width of *public way* or open space (feet) in accordance with Section 506.3.2.~~

~~Table 506.3.3.~~

~~$I_f = [F/P - 0.25]W/30$~~

Add new text as follows:

**Table 506.3.3
FRONTAGE INCREASE FACTOR**

<u>Percentage (%) of Perimeter</u>	<u>Open Space</u>			
	<u>0 to less than 20 Feet</u>	<u>20 to less than 25 Feet</u>	<u>25 to less than 30 Feet</u>	<u>30 Feet or greater</u>
<u>0 to less than 25</u>	<u>0</u>	<u>0</u>	<u>0</u>	<u>0</u>
<u>25 to less than 50</u>	<u>0</u>	<u>0.17</u>	<u>0.21</u>	<u>0.25</u>
<u>50 to less than 75</u>	<u>0</u>	<u>0.33</u>	<u>0.42</u>	<u>0.50</u>
<u>75 to 100</u>	<u>0</u>	<u>0.5</u>	<u>0.63</u>	<u>0.75</u>

Reason:

Calculating the frontage increase is a confusing process for little benefit. This proposal simplifies the process by creating a table outlining the increase based on the percentage of open space around the building and the distance of that open space. It still uses the concept of the percentage of open space around the building. The values in the table are based on the calculations using Equation 5-5. The proposal also deletes the confusing weighted average calculation that most people do not use.

For example, if you have a building that has a perimeter of open space of 63% and the smallest open space is 25 feet, the increase would be 0.42. Using the calculation in Equation 5-5, it would be 0.32. This is a 10% difference. The total increase for a Group B Occupancy of Type VB Construction would be 2,790 square feet using the equation and 3,780 using the table. This is a difference of 990 square feet. This is negligible in the overall scheme of allowable area calculations.

Cost Impact

The code change proposal will not increase or decrease the cost of construction .

This is a simplification of an existing calculation in the code. It should not affect the cost of construction.

Internal ID: 1071

G87-18

IBC: 508.3.1.2

Proponent: John Williams, Chair, representing Healthcare Committee (AHC@iccsafe.org)

2018 International Building Code

Revise as follows:

508.3.1.2 Group I-2, Condition 2 occupancies. Where one of the nonseparated occupancies is Group I-2, Condition 2, the ~~most restrictive~~ requirements of Sections 407, 509 and 712 shall apply throughout the fire area containing the Group I-2 occupancy. The ~~most restrictive~~ requirements of Chapter 10 for Group I-2, Condition 2 shall apply to the path of egress from the Group I-2, Condition 2 occupancy up to and including the exit discharge.

Reason:

This section relates to the use of non-separated mixed uses in hospitals. Historically a hospital building has broadly been considered as an I-2 occupancy. However, designs are increasingly using this non-separated option to create situations that adversely impact the I-2 occupancy. This language was added in the previous cycle to with the intent to require certain non-separated facility designs to follow some of the basic requirements for Group I-2, Condition 2 hospitals. The goal was to point designers and code officials to four key components to consider when designing non-separated uses: Section 407 which contains specific healthcare requirements, Section 509 for incidental uses, Section 712 for vertical openings and Chapter 10 for egress. Failure to follow these could have adverse impacts on patients and staff. For example, unprotected floor openings allowed by 712 are prohibited in Group I-2, they are not prohibited in Group B. Without this section, a design would be allowed to punch a hole in the floor that adversely affects the I-2 patients on that floor.

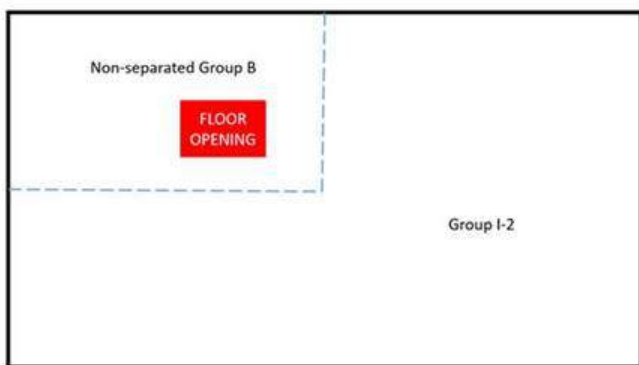

An unintended consequence of the language is that by referencing the “most restrictive” requirements, the section prohibits the use of any exception permissible for Group I-2. It also doesn’t clearly identify which requirements should be considered. For example, we did not intend to apply Group H restrictions on these conditions just because they are more restrictive. There are several exceptions that should be maintained for these parts of the building, especially in Chapter 10. This change clarifies that all of the I-2 specific requirements apply, whether they are more or less restrictive.

This proposal is submitted by the ICC Committee on Healthcare (CHC). The CHC was established by the ICC Board to evaluate and assess contemporary code issues relating to healthcare facilities. This is a joint effort between ICC and the American Society for Healthcare Engineering (ASHE), a subsidiary of the American Hospital Association, to eliminate duplication and conflicts in healthcare regulation. In 2017 the CHC held 2 open meetings and numerous conference calls, which included members of the committees as well as any interested parties, to discuss and debate the proposed changes. Information on the CHC, including: meeting agendas; minutes; reports; resource documents; presentations; and all other materials developed in conjunction with the CHC effort can be downloaded from the CHC website at: <https://www.iccsafe.org/codes-tech-support/cs/icc-committee-on-healthcare/>.

Cost Impact

The code change proposal will decrease the cost of construction .

This clarification would remove requirements for more restrictive provisions where hospital provisions apply.

Internal ID: 1288

G88-18

IBC: TABLE 508.4

Proponent: Ed Kullik, Chair, representing ICC Building Code Action Committee (bcac@iccsafe.org)

2018 International Building Code

Revise as follows:

**TABLE 508.4
REQUIRED SEPARATION OF OCCUPANCIES (HOURS)^f**

OCCUPANCY	A, E		I-1 ^a , I-3, I-4		I-2		R ^a		F-2, S-2 ^b , U		B ^e , F-1, M, S-1		H-1		H-2		H-3, H-4		H-5	
	S	NS	S	NS	S	NS	S	NS	S	NS	S	NS	S	NS	S	NS	S	NS	S	NS
A, E	N	N	1	2	2	NP	1	2	N	1	1	2	NP	NP	3	4	2	3	2	NP
I-1 ^a , I-3, I-4	<u>1</u>	<u>2</u>	N	N	2	NP	1	NP	1	2	1	2	NP	NP	3	NP	2	NP	2	NP
I-2	<u>2</u>	<u>NP</u>	<u>2</u>	<u>NP</u>	N	N	2	NP	2	NP	2	NP	NP	NP	3	NP	2	NP	2	NP
R ^a	<u>1</u>	<u>2</u>	<u>N</u>	<u>N</u>	<u>2</u>	<u>NP</u>	N	N	1 ^c	2 ^c	1	2	NP	NP	3	NP	2	NP	2	NP
F-2, S-2 ^b , U	<u>N</u>	<u>1</u>	<u>1</u>	<u>2</u>	<u>N</u>	<u>N</u>	<u>1^c</u>	<u>2^c</u>	N	N	1	2	NP	NP	3	4	2	3	2	NP
B ^e , F-1, M, S-1	<u>1</u>	<u>2</u>	<u>1</u>	<u>2</u>	<u>2</u>	<u>NP</u>	<u>N</u>	<u>N</u>	<u>1</u>	<u>2</u>	N	N	NP	NP	2	3	1	2	1	NP
H-1	<u>NP</u>	<u>NP</u>	<u>NP</u>	<u>NP</u>	<u>NP</u>	<u>NP</u>	<u>NP</u>	<u>NP</u>	<u>NP</u>	<u>NP</u>	<u>NP</u>	<u>NP</u>	N	NP	NP	NP	NP	NP	NP	NP
H-2	<u>3</u>	<u>4</u>	<u>3</u>	<u>NP</u>	<u>3</u>	<u>NP</u>	<u>3</u>	<u>NP</u>	<u>3</u>	<u>4</u>	<u>2</u>	<u>3</u>	<u>NP</u>	<u>NP</u>	N	NP	1	NP	1	NP
H-3, H-4	<u>2</u>	<u>3</u>	<u>2</u>	<u>NP</u>	<u>2</u>	NP	<u>2</u>	<u>NP</u>	<u>2</u>	<u>3</u>	<u>1</u>	<u>2</u>	<u>NP</u>	<u>NP</u>	<u>1</u>	<u>NP</u>	1 ^d	NP	1	NP
H-5	2	NP	2	NP	2	NP	2	NP	2	NP	1	NP	NP	NP	1	NP	1	NP	N	NP

S = Buildings equipped throughout with an automatic sprinkler system installed in accordance with Section 903.3.1.1.

NS = Buildings not equipped throughout with an automatic sprinkler system installed in accordance with Section 903.3.1.1.

N = No separation requirement.

NP = Not Permitted.

- a. See Section 420.
- b. The required separation from areas used only for private or pleasure vehicles shall be reduced by 1 hour but not to less than 1 hour.
- c. See Section 406.3.2.
- d. Separation is not required between occupancies of the same classification.
- e. See Section 422.2 for ambulatory care facilities.
- f. Occupancy separations that serve to define fire area limits established in Chapter 9 for requiring fire protection systems shall also comply with Section 707.3.10 and Table 707.3.10 in accordance with Section 901.7.

Reason:

Filling in the balance of Table 508.4 will avoid confusion and make the table more clear and functional.

Cost Impact

The code change proposal will not increase or decrease the cost of construction .

This proposal is an editorial change and adds no new requirements to the code.

Internal ID: 3018

G89-18

IBC: 508.4.4.1, 509.4.1.1 (New)

Proponent: Stephen DiGiovanni, representing ICC Ad Hoc Committee on Tall Wood Buildings (TWB) (TWB@iccsafe.org)

2018 International Building Code

508.4.4 Separation. Individual occupancies shall be separated from adjacent occupancies in accordance with Table 508.4.

Revise as follows:

508.4.4.1 Construction. Required separations shall be *fire barriers* constructed in accordance with Section 707 or *horizontal assemblies* constructed in accordance with Section 711, or both, so as to completely separate adjacent occupancies. Mass timber elements serving as fire barriers or horizontal assemblies to separate occupancies in Type IV-B or IV-C construction shall be separated from the interior of the building with an approved thermal barrier consisting of a minimum of $\frac{1}{2}$ inch (12.7 mm) gypsum board or a noncombustible equivalent.

Add new text as follows:

509.4.1.1 Type IV-B and IV-C construction. Where Table 509 specifies a fire-resistance-rated separation, mass timber elements serving as fire barriers or a horizontal assembly in Type IV-B or IV-C construction shall be separated from the interior of the incidental use with an approved thermal barrier consisting of a minimum of $\frac{1}{2}$ inch (12.7 mm) gypsum board or a noncombustible equivalent.

Reason:

The Ad Hoc Committee on Tall Wood Buildings (TWB) was created by the ICC Board to explore the science of tall wood buildings and take action on developing code changes for tall wood buildings. The TWB has created several code change proposals with respect to the concept of tall buildings of mass timber and the background information is at the end of this Statement. Within the statement are important links to information, including documents and videos, used in the deliberations which resulted in these proposals.

This code change proposal represents one of many submitted designed to address a new type of construction called mass timber (e.g. new construction types IV-A, IV-B, and IV-C).

On this subject of “fire barriers,” the committee determined that additional measures were necessary to address cases where mass timber is serving as a fire barrier or horizontal assembly. Section 508.4 describes the third option for separating mixed occupancies within a building. Section 509.4 discusses the fire-resistance rated separation that is required for incidental uses within a larger use group. Section 509 also permits, when stated, protection by an automatic sprinkler system without fire barriers, however the construction enclosing the incidental use must resist the passage of smoke in accordance with Section 509.4.2.

The concern is that without any modifications to these provisions regulating separated occupancies and incidental uses, a fire barrier or horizontal assembly could be designed using mass timber that would comply with the fire resistance rating, but which would allow any exposed mass timber to contribute to the fuel load. This can occur in Types IV-B and IV-C construction.

The committee applied professional judgment by choosing to emulate the existing thermal barrier requirements by applying those requirements to these two sections. The intent of this proposal is to have the thermal barrier delay or prevent the ignition of the mass timber, thus delaying or preventing the mass timber’s contribution to the fuel load. This will also allow additional time for fire and life safety measures to be executed as well as allow first responders additional time to perform their services.

The committee’s intent is that the thermal barrier only needs to cover an exposed wood surface. The thermal barrier is not required in addition to any noncombustible protection that is required in Section 602.4, nor does it add to the fire resistance rating of the mass timber.

Mass timber walls or floors serving as fire barriers for separated uses (Section 508.4) would need to have a thermal barrier on both faces of the assembly.

For Section 509.4 (incidental use separations) the intent is to provide the thermal barrier only on the side where the hazard exists, that is, the side facing the incidental use. For example, if a mass timber floor assembly of the incidental use contains a noncombustible topping this provision would not require the addition of a thermal barrier on mass timber surfaces not facing the incidental use area. In addition, the thermal barrier would not be required if the sprinkler option is exercised.

It should be noted that this proposal is only addressing the contribution of exposed mass timber's face to the fuel load of a fire, and is not recommending any modifications to the fire resistance requirements of Sections 508 or 509 or to the other mass timber provisions.

Background information: The ICC Board approved the establishment of an ad hoc committee for tall wood buildings in December of 2015. The purpose of the ad hoc committee is to explore the science of tall wood buildings and to investigate the feasibility and take action on developing code changes for tall wood buildings. The committee is comprised of a balance of stakeholders with additional opportunities for interested parties to participate in the four Work Groups established by the ad hoc committee, namely: Code; Fire; Standards/Definitions; and Structural. For more information, be sure to visit the ICC website <https://www.iccsafe.org/codes-tech-support/cs/icc-ad-hoc-committee-on-tall-wood-buildings/> (link active and up to date as of 12/27/17). As seen in the "Meeting Minutes and Documents" and "Resource Documents" sections of the committee web page, the ad hoc committee reviewed a substantial amount of information in order to provide technical justification for code proposals.

The ad hoc committee developed proposals for the followings code sections. The committee believes this package of code changes will result in regulations that adequately address the fire and life safety issues of tall mass timber buildings.

IBC Code Section	Description
403.3.2	Water supply requirements for fire pumps in high rise buildings of Type IVA and IVB construction.
504.3	Allowable building height (feet) for buildings of Type IVA, IVB and IVC construction. No changes to Type IV HT construction.
504.4	Allowable building height (stories) for buildings of Type IVA, IVB and IVC construction. No changes to Type IV HT.
506.2	Allowable building area for buildings of Type IVA, IVB and IVC construction. No changes to Type IV HT.
508.4.4.1 509.4.1.1 (new)	Requirements for mass timber building elements serving as fire barriers or horizontal assemblies in buildings of Type IVB or IVC construction.
602.4	Type of Construction requirements for new proposed types of construction: Types IVA, IVB and IVC. No changes to Type IV HT construction. Includes definitions for new terms: Mass timber and Noncombustible protection (mass timber). THIS IS THE KEY CODE CHANGE PROPOSAL WHICH OUTLINES THE CONSTRUCTION REQUIREMENTS FOR THE PROPOSED NEW TYPE OF MASS TIMBER BUILDINGS. THE PROPOSAL ALSO ADDRESSES CONCEALED SPACES, ADHESIVE PERFORMANCE AND EXTERIOR WALL PROTECTION.
703.8 (new)	The performance method to determine the increase to the fire resistance rating provided by noncombustible protection applied to the mass timber building element.
703.9 (new)	Requirements for sealants and adhesives to be placed at abutting edges and intersections of mass timber building elements. The reason statement references a Group B proposal to Chapter 17 for special inspection requirements of sealants and adhesives.
718.2.1	Requirements on the use of mass timber building elements used for Fireblocking.
722.7 (new)	Requirements for the fire resistance rating of mass timber elements, including minimum required protection and gypsum board attachment requirements.
3102	Requirements for membrane structures using Type IV HT construction.
3314.7 (new)	New special precautions during construction of buildings of Types IVA, IVB and IVC construction: Standpipes; Water supply for fire department connections; Noncombustible protection required for mass timber elements as construction height increases.
Appendix	Requirements for walls, floors and roofs of Type IV HT construction in buildings located in Fire Districts.
IFC Code Section	Description
701.6	Requirements which stipulate the owner's responsibility to maintain inventory of all required fire resistance rated construction in buildings of Types IVA and IVB construction. This includes an annual inspection and proper repair where necessary.
Proposed changes to be submitted in 2019 Group B	
IBC Chapter 17	Required special inspections of mass timber construction <ul style="list-style-type: none"> • Structural • Sealants and adhesives (see IBC 703.8)
IBC Chapter 23	An update to referenced standard APA PRG 320 Standard for Performance –rated Cross-laminated Timber which is currently undergoing revision to ensure the adequacy of the adhesives under fire conditions.

In addition, fire tests designed to simulate the three new construction types (Types IVA, IVB and IVC) in the ad hoc committee proposals were conducted at the Alcohol Tobacco and Firearms test lab facility. The TWB was involved in the design of the tests, and many members witnessed the test in person or online. The results of the series of 5 fire tests provide additional support for these proposals, and validate the fire performance for each of the types of construction proposed by the committee. The fire tests consisted of one-bedroom apartments on two levels, with both apartments having a corridor leading to a stair. The purpose of the tests was to address the contribution of mass timber to a fire, the performance of connections, the performance of through-penetration fire stops, and to evaluate conditions for responding fire personnel.

To review a summary of the fire tests, please visit:

<http://bit.ly/ATF-firetestreport>

To watch summary videos of the fire tests, which are accelerated to run in 3 ½ minutes, please visit:

<http://bit.ly/ATF-firetestvideos>

Both of these links were confirmed active on 12/27/17.

Cost Impact

The code change proposal will not increase or decrease the cost of construction .

This section provides information that was not previously set forth in the code, and does not change the requirements of current code, thus there is no cost impact when compared with present requirements.

Internal ID: 960

G90-18

IBC: 508.1, 508.5, 508.5.1, 508.5.2, 508.5.3, 508.5.4, 508.5.5, 508.5.6, 508.5.7, 508.5.8, 508.5.9, 508.5.10, 508.5.11

Proponent: Ed Kullik, Chair, representing ICC Building Code Action Committee (bcac@iccsafe.org)

2018 International Building Code

Delete without substitution:

~~SECTION 419 LIVE/WORK UNITS~~

Revise as follows:

508.1 General. Each portion of a building shall be individually classified in accordance with Section 302.1. Where a building contains more than one occupancy group, the building or portion thereof shall comply with the applicable provisions of Section 508.2, 508.3 ~~or~~, 508.4, 508.5, or a combination of these sections.

Exceptions:

1. Occupancies separated in accordance with Section 510.
2. Where required by Table 415.6.2, areas of Group H-1, H-2 and H-3 occupancies shall be located in a *detached building* or structure.
3. ~~Uses within live/work units, complying with Section 419, are not considered separate occupancies.~~

~~419.1-508.5~~ **General/Live/Work Units.** A *live/work unit* shall comply with Sections ~~419.1-508.5~~ through ~~419.9-508.5.11~~.

Exception: Dwelling or sleeping units that include an office that is less than 10 percent of the area of the *dwelling unit* are permitted to be classified as *dwelling units* with accessory occupancies in accordance with Section 508.2.

~~419.1-1508.5.1~~ **Limitations.** All of the following shall apply to live/work areas:

1. The *live/work unit* is permitted to be not greater than 3,000 square feet (279 m²) in area.
2. The nonresidential area is permitted to be not more than 50 percent of the area of each *live/work unit*.
3. The nonresidential area function shall be limited to the first or main floor only of the *live/work unit*.
4. Not more than five nonresidential workers or employees are allowed to occupy the nonresidential area at any one time.

~~419.2-508.5.2~~ **Occupancies.** *Live/work units* shall be classified as a Group R-2 occupancy. Separation requirements found in Sections 420 and 508 shall not apply within the *live/work unit* where the *live/work unit* is in compliance with Section ~~419-508.5~~. Nonresidential uses that would otherwise be classified as either a Group H or S occupancy shall not be permitted in a *live/work unit*.

Exception: Storage shall be permitted in the *live/work unit* provided that the aggregate area of storage in the nonresidential portion of the *live/work unit* shall be limited to 10 percent of the space dedicated to nonresidential activities.

~~419.3-508.5.3~~ **Means of egress.** Except as modified by this section, the *means of egress* components for a *live/work unit* shall be designed in accordance with Chapter 10 for the function served.

~~419.3-1508.5.4~~ **Egress capacity.** The egress capacity for each element of the *live/work unit* shall be based on the occupant load for the function served in accordance with Table 1004.5.

~~419.3-2508.5.5~~ **Spiral stairways.** *Spiral stairways* that conform to the requirements of Section 1011.10 shall be permitted.

~~419.4-508.5.6~~ **Vertical openings.** Floor openings between floor levels of a *live/work unit* are permitted without enclosure.

[F] ~~419.5-508.5.7~~ **Fire protection.** The *live/work unit* shall be provided with a monitored *fire alarm* system where

required by Section 907.2.9 and an *automatic sprinkler system* in accordance with Section 903.2.8.

419-6508.5.8 Structural. Floors within a *live/work unit* shall be designed for the live loads in Table 1607.1, based on the function within the space.

419-7508.5.9 Accessibility. Accessibility shall be designed in accordance with Chapter 11 for the function served.

419-8508.5.10 Ventilation. The applicable *ventilation* requirements of the International Mechanical Code shall apply to each area within the *live/work unit* for the function within that space.

419-9508.5.11 Plumbing facilities. The nonresidential area of the *live/work unit* shall be provided with minimum plumbing facilities as specified by Chapter 29, based on the function of the nonresidential area. Where the nonresidential area of the *live/work unit* is required to be *accessible* by Section 1107.6.2.1, the plumbing fixtures specified by Chapter 29 shall be *accessible*.

Reason:

Relocating Section 419 on Live/Work Units to Section 508 Mixed Occupancies provides a clearer description under Mixed Use Occupancies since the unit is not only residential nor business use. An example is a doctor's office occupying part of a detached dwelling, or townhouses with an office, store or restaurant on the first floor and a residence occupying parts or all of upper floors.

This proposal is submitted by the ICC Building Code Action Committee (BCAC). BCAC was established by the ICC Board of Directors in July 2011 to pursue opportunities to improve and enhance assigned International Codes or portions thereof. In 2017 the BCAC has held 3 open meetings. In addition, there were numerous Working Group meetings and conference calls for the current code development cycle, which included members of the committee as well as any interested party to discuss and debate the proposed changes. Related documentation and reports are posted on the BCAC website at: <https://www.iccsafe.org/codes-tech-support/codes/code-development-process/building-code-action-committee-bcac>.

Cost Impact

The code change proposal will not increase or decrease the cost of construction .

This is an editorial relocation of existing requirements.

Internal ID: 2257

G91-18

IBC: [F] TABLE 509

Proponent: Ed Kullik, Chair, representing ICC Building Code Action Committee (BCAC@iccsafe.org)

THIS CODE CHANGE WILL BE HEARD BY THE FIRE CODE COMMITTEE. SEE THE TENTATIVE HEARING ORDER FOR THIS COMMITTEE

2018 International Building Code

Revise as follows:

**[F] TABLE 509
INCIDENTAL USES**

ROOM OR AREA	SEPARATION AND/OR PROTECTION
Furnace room where any piece of equipment is over 400,000 Btu per hour input ^a	1 hour or provide automatic sprinkler system
Rooms with boilers where the largest piece of equipment is over 15 psi and 10 horsepower ^a	1 hour or provide automatic sprinkler system
Refrigerant machinery room ^a	1 hour or provide automatic sprinkler system
Hydrogen fuel gas rooms, not classified as Group H	1 hour in Group B, F, M, S and U occupancies; 2 hours in Group A, E, I and R occupancies.
Incinerator rooms ^a	2 hours and provide automatic sprinkler system
Paint shops, not classified as Group H, located in occupancies other than Group F	2 hours; or 1 hour and provide automatic sprinkler system
In Group E occupancies, laboratories and vocational shops not classified as Group H	1 hour or provide automatic sprinkler system
In Group I-2 occupancies, laboratories not classified as Group H	1 hour and provide automatic sprinkler system
In ambulatory care facilities, laboratories not classified as Group H	1 hour or provide automatic sprinkler system
Laundry rooms over 100 square feet	1 hour or provide automatic sprinkler system
In Group I-2, laundry rooms over 100 square feet	1 hour
Group I-3 cells and Group I-2 patient rooms equipped with padded surfaces	1 hour
In Group I-2, physical plant maintenance shops	1 hour
In ambulatory care facilities or Group I-2 occupancies, waste and linen collection rooms with containers that have an aggregate volume of 10 cubic feet or greater	1 hour
In other than ambulatory care facilities and Group I-2 occupancies, waste and linen collection rooms over 100 square feet	1 hour or provide automatic sprinkler system
In ambulatory care facilities or Group I-2 occupancies, storage rooms greater than 100 square feet	1 hour
Stationary storage battery systems having an energy capacity greater than the threshold quantity specified in Table 1206.2 of the International Fire Code	1 hour in Group B, F, M, S and U occupancies; 2 hours in Group A, E, I and R occupancies.
Electrical installations and transformers ^a	See Sections 110.26 through 110.34 and Sections 450.8 through 450.48 of NFPA 70 for protection and separation requirements.

For SI: 1 square foot = 0.0929 m², 1 pound per square inch (psi) = 6.9 kPa, 1 British thermal unit (Btu) per hour = 0.293 watts, 1 horsepower = 746 watts, 1 gallon = 3.785 L, 1 cubic foot = 0.0283 m³.

a. See Chapter 6 of the International Fire Code for additional construction related requirements.

Reason:

This proposal is submitted by the ICC Building Code Action Committee (BCAC). BCAC was established by the ICC Board of Directors in July 2011 to pursue opportunities to improve and enhance assigned International Codes or portions thereof. In 2017 the BCAC has held 3 open meetings. In addition, there were numerous Working Group meetings and conference calls for the current code development cycle, which included members of the committee as well as any interested party to discuss and debate the proposed changes. Related documentation and reports are posted on the BCAC website at: <https://www.iccsafe.org/codes-tech-support/codes/code-development-process/building-code-action-committee-bcac>.

This is a simple footnote pointer so designers are aware of additional construction and/or installation requirements for these incidental use building systems that are located in Chapter 6 of the International Fire Code.

This proposal is part of a comprehensive update to IFC Chapter 6 by the F-CAC. F-CAC fully supports this proposal.

Cost Impact

The code change proposal will not increase or decrease the cost of construction .

This proposal adds a pointer to existing requirements in the IFC. No new or additional construction requirements are being introduced into the IBC.

Internal ID: 347

G92-18

IBC: [F] TABLE 509

Proponent: Ed Kullik, Chair, representing ICC Building Code Action Committee (bcac@iccsafe.org); Robert Davidson, Davidson Code Concepts, LLC, representing Tesla, USA (rjd@davidsoncodeconcepts.com)

THIS CODE CHANGE WILL BE HEARD BY THE FIRE CODE COMMITTEE. SEE THE TENTATIVE HEARING ORDER FOR THIS COMMITTEE

2018 International Building Code

Revise as follows:

**[F] TABLE 509
INCIDENTAL USES**

ROOM OR AREA	SEPARATION AND/OR PROTECTION
Furnace room where any piece of equipment is over 400,000 Btu perhour input	1 hour or provide automatic sprinkler system
Rooms with boilers where the largest piece of equipment is over 15psi and 10 horsepower	1 hour or provide automatic sprinkler system
Refrigerant machinery room	1 hour or provide automatic sprinkler system
Hydrogen fuel gas rooms, not classified as Group H	1 hour in Group B, F, M, S and U occupancies; 2 hours in Group A, E,I and R occupancies.
Incinerator rooms	2 hours and provide automatic sprinkler system
Paint shops, not classified as Group H, located in occupancies otherthan Group F	2 hours; or 1 hour and provide automatic sprinkler system
In Group E occupancies, laboratories and vocational shops notclassified as Group H	1 hour or provide automatic sprinkler system
In Group I-2 occupancies, laboratories not classified as Group H	1 hour and provide automatic sprinkler system
In ambulatory care facilities, laboratories not classified as Group H	1 hour or provide automatic sprinkler system
Laundry rooms over 100 square feet	1 hour or provide automatic sprinkler system
In Group I-2, laundry rooms over 100 square feet	1 hour
Group I-3 cells and Group I-2 patient rooms equipped with padded surfaces	1 hour
In Group I-2, physical plant maintenance shops	1 hour
In ambulatory care facilities or Group I-2 occupancies, waste and linen collection rooms with containers that have an aggregate volume of 10 cubic feet or greater	1 hour
In other than ambulatory care facilities and Group I-2 occupancies, waste and linen collection rooms over 100 square feet	1 hour or provide automatic sprinkler system
In ambulatory care facilities or Group I-2 occupancies, storage rooms greater than 100 square feet	1 hour
Stationary storage battery systems having an energy capacity greater than the threshold quantity specified in Table 1206.2 of the International Fire Code	1 hour in Group B, F, M, S and U occupancies; 2 hours in Group A, E, I and R occupancies.
Electrical installations and transformers	See Sections 110.26 through 110.34 and Sections 450.8 through 450.48 of NFPA 70 for protection and separation requirements.

For SI: 1 square foot = 0.0929 m², 1 pound per square inch (psi) = 6.9 kPa, 1 British thermal unit (Btu) per hour = 0.293 watts, 1 horsepower = 746 watts, 1 gallon = 3.785 L, 1 cubic foot = 0.0283 m³.

Reason:

This proposal eliminates stationary storage battery systems as incidental use from Table 509. A rewrite of the IFC Section 1206 has added extensive protection features to such installations including detection, suppression, fire separation, and explosion control, along with large scale testing to document the effectiveness of chosen protection levels. With the increased level of protection mandated by the IFC, there is no longer a need to limit such uses to 10% of a floor area as an incidental use.

This proposal is submitted by the ICC Building Code Action Committee (BCAC). BCAC was established by the ICC Board of Directors in July 2011 to pursue opportunities to improve and enhance assigned International Codes or portions thereof. In 2017 the BCAC has held 3 open meetings. In addition, there were numerous Working Group meetings and conference calls for the current code development cycle, which included members of the committee as well as any interested party to discuss and debate the proposed changes. Related documentation and reports are posted on the BCAC website at: <https://www.iccsafe.org/codes-tech-support/codes/code-development-process/building-code-action-committee-bcac>.

Cost Impact

The code change proposal will decrease the cost of construction .

Eliminating the incidental use 10% floor area restriction can reduce the cost of providing energy storage systems in mixed use buildings.

Internal ID: 251

G93-18

IBC: 509.3

Proponent: David Collins, representing The American Institute of Architects (dcollins@preview-group.com); Stephen Thomas, Colorado Code Consulting, LLC, representing Colorado Chapter ICC (sthomas@coloradocode.net)

2018 International Building Code

**[F] TABLE 509
INCIDENTAL USES**

ROOM OR AREA	SEPARATION AND/OR PROTECTION
Furnace room where any piece of equipment is over 400,000 Btu per hour input	1 hour or provide automatic sprinkler system
Rooms with boilers where the largest piece of equipment is over 15 psi and 10 horsepower	1 hour or provide automatic sprinkler system
Refrigerant machinery room	1 hour or provide automatic sprinkler system
Hydrogen fuel gas rooms, not classified as Group H	1 hour in Group B, F, M, S and U occupancies; 2 hours in Group A, E, I and R occupancies.
Incinerator rooms	2 hours and provide automatic sprinkler system
Paint shops, not classified as Group H, located in occupancies other than Group F	2 hours; or 1 hour and provide automatic sprinkler system
In Group E occupancies, laboratories and vocational shops not classified as Group H	1 hour or provide automatic sprinkler system
In Group I-2 occupancies, laboratories not classified as Group H	1 hour and provide automatic sprinkler system
In ambulatory care facilities, laboratories not classified as Group H	1 hour or provide automatic sprinkler system
Laundry rooms over 100 square feet	1 hour or provide automatic sprinkler system
In Group I-2, laundry rooms over 100 square feet	1 hour
Group I-3 cells and Group I-2 patient rooms equipped with padded surfaces	1 hour
In Group I-2, physical plant maintenance shops	1 hour
In ambulatory care facilities or Group I-2 occupancies, waste and linen collection rooms with containers that have an aggregate volume of 10 cubic feet or greater	1 hour
In other than ambulatory care facilities and Group I-2 occupancies, waste and linen collection rooms over 100 square feet	1 hour or provide automatic sprinkler system
In ambulatory care facilities or Group I-2 occupancies, storage rooms greater than 100 square feet	1 hour
Stationary storage battery systems having an energy capacity greater than the threshold quantity specified in Table 1206.2 of the International Fire Code	1 hour in Group B, F, M, S and U occupancies; 2 hours in Group A, E, I and R occupancies.
Electrical installations and transformers	See Sections 110.26 through 110.34 and Sections 450.8 through 450.48 of NFPA 70 for protection and separation requirements.

For SI: 1 square foot = 0.0929 m², 1 pound per square inch (psi) = 6.9 kPa, 1 British thermal unit (Btu) per hour = 0.293 watts, 1 horsepower = 746 watts, 1 gallon = 3.785 L, 1 cubic foot = 0.0283 m³.

509.2 Occupancy classification. Incidental uses shall not be individually classified in accordance with Section 302.1. Incidental uses shall be included in the building occupancies within which they are located.

Delete without substitution:

~~**509.3 Area limitations.** Incidental uses shall not occupy more than 10 percent of the *building area* of the story in which they are located.~~

Reason:

We submitted changes to eliminate the 10% area limitation on incidental uses over the last two code cycles. Each of those proposals were disapproved by the committee and the membership. We were told by the opponents, the way to fix the problem is to require incidental uses over 10% of the story area to be classified as an occupancy. Independently we each drafted a proposed change to say that if one incidental use; or an aggregate of incidental uses on a story exceeds the 10% limit that they would be classified as a distinct occupancy. The more we tried to provide rationale for such a change, to more the construct came crashing down.

The original purpose of incidental uses that are all specifically listed in Table 509 is to address a hazard of one type or another. Each of the uses in Table 509 poses a hazard to the balance of the primary use of the building or story. The solutions to address those risks are rated separations, automatic sprinkler system or both. The hazard exists whether the use is 5% of a story, 15% or a story or 50% of a story. The protection needs to be provided regardless of the area of the incidental use(s). The 10% limit is particularly impractical and onerous if strictly enforced on the health care industry. Laboratories, laundry rooms, maintenance shops, storage rooms; waste and linen collection - going over 10% is a frequent design issue.

The solution urged on us is to say things that are an incidental use when limited to 10% of the story (and part of the primary occupancy) are to be called a different occupancy when they get larger doesn't work either way you try to wrap the code around it.

A. Distinct uses - no longer incidental uses. If we say that these uses exceeding 10% of story are something else and no longer an incidental use, then the protections required by Table 509 disappear. If we assign other occupancies then we are left to rely on Section 508 mixed occupancies to provide protections. But often the protections will be less. In a non-separated approach you may get a fully sprinklered building, but you won't get rated separations. In a separated mixed occupancy approach you might get sprinklers; you might get rated separations; and sometimes you might get both, but you aren't going to be assured of the protections required for the smaller things allowed under incidental uses.

B. Distinct uses - but still incidental uses. If we say that these uses exceeding 10% are another occupancy AND remain an incidental use in order to preserve the protections. What have we done? We've proved that the 10% limit is meaningless because you are still getting the protections of incidental uses regardless of size.

A final point about assigning other occupancy categories to these uses (when exceeding 10%) is that the application of the code will be inconsistent from jurisdiction to jurisdiction; from project to project.

Eliminating the 10% limit makes sure that each of these uses in Table 509 will be consistently protected from project to project; jurisdiction to jurisdiction.

Cost Impact

The code change proposal will not increase or decrease the cost of construction .

This is intended to clarify the code language.

Internal ID: 239

G94-18

IBC: 510.2

Proponent: Lawrence Lincoln, Salt Lake City Corporation, representing Self (larry.lincoln@slcgov.com)

2018 International Building Code

510.2 Horizontal building separation allowance. A building shall be considered as separate and distinct buildings for the purpose of determining area limitations, continuity of *fire walls*, limitation of number of *stories* and type of construction where all of the following conditions are met:

1. The buildings are separated with a *horizontal assembly* having a *fire-resistance rating* of not less than 3 hours. Where vertical offsets are provided as part of a *horizontal assembly*, the vertical offset and the structure supporting the vertical offset shall have a *fire-resistance rating* of not less than 3 hours.
2. The building below, including the *horizontal assembly*, is of Type IA construction.
3. *Shaft, stairway, ramp* and escalator enclosures through the *horizontal assembly* shall have not less than a 2-hour *fire-resistance rating* with opening protectives in accordance with Section 716.

Exception: Where the enclosure walls below the *horizontal assembly* have not less than a 3-hour *fire-resistance rating* with opening protectives in accordance with Section 716, the enclosure walls extending above the *horizontal assembly* shall be permitted to have a 1-hour *fire-resistance rating*, provided:

1. The building above the *horizontal assembly* is not required to be of Type I construction;
 2. The enclosure connects fewer than four *stories*; and
 3. The enclosure opening protectives above the *horizontal assembly* have a *fire protection rating* of not less than 1 hour.
4. Where buildings above the horizontal assembly are of Type III, IV or V construction, stairways within enclosures specified in Item 3 shall be constructed of either noncombustible materials or fire retardant treated wood.

~~5.4-~~The building or buildings above the *horizontal assembly* shall be permitted to have multiple Group A occupancy uses, each with an *occupant load* of less 300, or Group B, M, R or S occupancies.

~~6.5-~~ The building below the *horizontal assembly* shall be protected throughout by an approved *automatic sprinkler system* in accordance with Section 903.3.1.1, and shall be permitted to be any occupancy allowed by this code except Group H.

~~7.6-~~The maximum *building height* in feet (mm) shall not exceed the limits set forth in Section 504.3 for the building having the smaller allowable height as measured from the *grade plane*.

Reason:

IBC section 1011.7 requires that Stairway construction be built of materials consistent with the types permitted for the type of construction of the building. Buildings designed in accordance with section 510.2 are inherently of two different types of construction where the horizontal assembly is the dividing line. When taking into consideration the materials that would be consistent with the type of construction of the stairway construction within a fire-rated stair enclosure, the transition from combustible materials (above the horizontal assembly) to noncombustible materials (below the horizontal assembly) makes no sense within the fire-rated stair enclosure when the type of construction above the horizontal assembly is of type III, IV or V and the type of construction below the horizontal assembly is type I-A (required by section 510.2). In other words, it makes no sense to transition from combustible materials to noncombustible materials when you are within the same environment (the fire-rated stair enclosure). Please note that this code proposal would allow fire-retardant-treated wood as a construction material within that portion of the fire-rated stair enclosure that is part of the type I-A construction. Since fire is never anticipated to originate within a fire-rated stair enclosure, this allowance seems reasonable.

Cost Impact

The code change proposal will decrease the cost of construction .

The proposed code change will decrease the cost of construction as this code change would lessen a code requirement.

Internal ID: 2337

G95-18

IBC: 510.2, 1011.7, 1023.2 (IFC[BE] 1011.7, 1023.2)

Proponent: Lee Kranz, representing City of Bellevue, WA (lkranz@bellevuewa.gov)

2018 International Building Code

Revise as follows:

510.2 Horizontal building separation allowance. A building shall be considered as separate and distinct buildings for the purpose of determining area limitations, continuity of *fire walls*, limitation of number of *stories* and type of construction where all of the following conditions are met:

1. The buildings are separated with a *horizontal assembly* having a *fire-resistance rating* of not less than 3 hours. Where vertical offsets are provided as part of a *horizontal assembly*, the vertical offset and the structure supporting the vertical offset shall have a *fire-resistance rating* of not less than 3 hours.
2. The building below, including the *horizontal assembly*, is of Type IA construction.
3. *Shaft, stairway, ramp* and escalator enclosures through the *horizontal assembly* shall have not less than a 2-hour *fire-resistance rating* with opening protectives in accordance with Section 716.

Exception: Where the enclosure walls below the *horizontal assembly* have not less than a 3-hour *fire-resistance rating* with opening protectives in accordance with Section 716, the enclosure walls extending above the *horizontal assembly* shall be permitted to have a 1-hour *fire-resistance rating*, provided:

1. The building above the *horizontal assembly* is not required to be of Type I construction;
 2. The enclosure connects fewer than four *stories*; and
 3. The enclosure opening protectives above the *horizontal assembly* have a *fire protection rating* of not less than 1 hour.
4. Interior exit stairways located within the Type IA building are permitted to be of combustible materials where both of the following requirements are met:
 - 4.1. The building above the Type IA building is of Type III, IV, or V construction.
 - 4.2. The stairway located in the Type IA building is enclosed by 3-hour fire-resistance rated construction with opening protectives in accordance with Section 716.
 5. The building or buildings above the *horizontal assembly* shall be permitted to have multiple Group A occupancy uses, each with an *occupant load* of less than 300, or Group B, M, R or S occupancies.
 - 5-6. The building below the *horizontal assembly* shall be protected throughout by an approved *automatic sprinkler system* in accordance with Section 903.3.1.1, and shall be permitted to be any occupancy allowed by this code except Group H.
 - 6-7. The maximum *building height* in feet (mm) shall not exceed the limits set forth in Section 504.3 for the building having the smaller allowable height as measured from the *grade plane*.

1011.7 Stairway construction. *Stairways* shall be built of materials consistent with the types permitted for the type of construction of the building, ~~except that wood handrails shall be permitted for all types of construction.~~

Exceptions:

1. Wood handrails shall be permitted in all types of construction.
2. Interior exit stairway in accordance with Section 510.2

1023.2 Construction. Enclosures for interior exit *stairways* and *ramps* shall be constructed as *fire barriers* in accordance with Section 707 or *horizontal assemblies* constructed in accordance with Section 711, or both. *Interior exit stairway* and *ramp* enclosures shall have a *fire-resistance rating* of not less than 2 hours where connecting four stories or more and not less than 1 hour where connecting less than four stories. The number of stories connected by the interior exit *stairways* or *ramps* shall include any *basements*, but not any *mezzanines*. *Interior exit stairways* and *ramps* shall have a *fire-resistance rating* not less than the floor assembly penetrated, but need not exceed 2 hours.

Exceptions:

1. *Interior exit stairways* and *ramps* in Group I-3 occupancies in accordance with the provisions of

Section 408.3.8.

2. *Interior exit stairways* within an *atrium* enclosed in accordance with Section 404.6.
3. Interior exit stairway in accordance with Section 510.2.

Reason:

In podium buildings utilizing a 3-hour fire-resistance rated horizontal assembly constructed in accordance with Section 510.2 it is very common for the building above the horizontal assembly to be of combustible construction, including the landings, stair stringers and treads. The code currently requires that a transition be made from wood to metal, or some other non-combustible materials, within the stair enclosure at the point where the stair goes from being located in a combustible building to the Type IA non-combustible building. This is not practical or warranted. Fires do not typically start within the fire-resistance rated stair enclosure. Exception #4.2 of this proposal provides additional protection by requiring that the stair shaft be of not less than a 3-hour fire resistance rating with 3-hour rated door assemblies as required by Section 716. This essentially creates a vertical offset of the 3-hour horizontal assembly which is currently allowed by Section 510.2. This section states that "Where vertical offsets are provided as part of a horizontal assembly, the vertical offset and the structure supporting the vertical offset shall have a fire-resistance rating of not less than 3 hours."

We have also included two 'pointer' exceptions in Chapter 10. Without the pointer exceptions someone might argue that these Chapter 10 provisions are more restrictive and override the exception in 510.2. The exemption for wood handrails currently found in the text of Section 1011.7 has been reformatted by placing it into exception #1.

Cost Impact

The code change proposal will decrease the cost of construction .

Allowing stairs to be of combustible construction will be less expensive than if they were required to be of non-combustible materials. Also, the cost to design the stair will be reduced because a transition from wood to steel (or other non-combustible materials) will no longer be required.

Internal ID: 83

G96-18

IBC: 510.3

Proponent: David Collins, The American Institute of Architects, representing The American Institute of Architects (dcollins@preview-group.com)

2018 International Building Code

Revise as follows:

510.3 Group S-2 enclosed parking garage with Group S-2 open parking garage above. A Group S-2 enclosed parking garage with not more than one *story above grade plane* and located below a Group S-2 open *parking garage* shall be classified as a separate and distinct building for the purpose of determining the type of construction where all of the following conditions are met:

1. The allowable area of the building shall be such that the sum of the ratios of the actual area divided by the allowable area for each separate occupancy shall not exceed 1.
2. The Group S-2 enclosed parking garage is of Type I or II construction and is at least equal to the *fire-resistance* requirements of the Group S-2 *open parking garage*.
3. The height and the number of tiers of the Group S-2 *open parking garage* shall be limited as specified in Table 406.5.4.
4. The floor assembly separating the Group S-2 enclosed parking garage and Group S-2 *open parking garage* shall be protected as required for the floor assembly of the Group S-2 enclosed parking garage. Openings between the Group S-2 enclosed parking garage and Group S-2 *open parking garage*, except *exit* openings, shall not be required to be protected.
5. The Group S-2 enclosed parking garage is used exclusively for the parking or storage of private motor vehicles, but shall be permitted to contain an office, waiting room and toilet room having a total area of not more than 1,000 square feet (93 m²) and mechanical equipment rooms ~~incidental to associated with~~ the operation of the building.

Reason:

The use of the term incidental can be confused with Section 509 and the list in Table 509. Office, waiting room and toilet rooms are not "incidental" per Section 509.

Cost Impact

The code change proposal will decrease the cost of construction .

Reducing the confusion over what is permitted within a garage will reduce the time required for design, review and approval of projects and will thus reduce costs.

Internal ID: 1748

G97-18

IBC: 510.4

Proponent: David Collins, representing The American Institute of Architects (dcollins@preview-group.com)

2018 International Building Code

Revise as follows:

510.4 Parking beneath Group R. Where a ~~maximum one story above grade plane~~ Group S-2 parking garage, ~~one story above grade plane~~, enclosed or open, or combination thereof, of Type I construction or open of Type IV construction, with a grade entrance, is ~~provided under~~ located below a building of Group R building, the ~~Group S-2 parking garage and Group R building shall be considered separate and distinct buildings~~. The number of *stories* to be used in determining the minimum type of construction ~~of the Group R building~~ shall be measured from the floor above ~~such a the parking area garage~~. The floor assembly between the parking garage and the Group R above shall comply with the type of construction required for the parking garage and shall also provide a *fire-resistance rating* not less than the mixed occupancy separation required in Section 508.4. The maximum building height in feet shall not exceed the limits set forth in Section 504.3 for the building having the smaller allowable height as measured from the grade plane.

Reason:

The current language in this section is confusing and awkward. This section addresses the upper height limit in stories, but does not address it in feet.

Cost Impact

The code change proposal will decrease the cost of construction .

By clarifying the intent of the code the cost of design, review and approval of projects should be simplified and reduce the overall cost of construction.

Internal ID: 1749

G98-18

IBC: 510.5

Proponent: Lee Kranz, City of Bellevue, WA, representing City of Bellevue, WA (lkranz@bellevuewa.gov)

2018 International Building Code

Revise as follows:

510.5 Group R-1 and R-2 buildings of Type IIIA construction. ~~The height limitation for~~ For buildings of Type IIIA construction in Groups R-1 and R-2 the maximum allowable height in Table 504.3 shall be increased to six stories and 75 feet (22 860 mm) by 10 feet and the maximum allowable number of stories in Table 504.4 shall be increased by one where the first floor assembly above the *basement* has a *fire-resistance rating* of not less than 3 hours and the floor area is subdivided by 2-hour fire-resistance-rated *fire walls* into areas of not more than 3,000 square feet (279 m2).

Reason:

The 20 foot increase in building height and one additional story specified in Section 504.2 of the 2012 IBC was deleted and replaced by Tables 504.3 and 504.4 in the 2015 IBC. Tables 504.3 and 504.4 include the increases that used to be specified in Section 504.2 of the 2012 IBC. This created an anomaly in Section 510.5 for height in the current code. Section 510.5 now specifies that the height for Group R-1 and R-2 of Type III-A construction shall be increased to 75' if the building complies with the conditions indicated in this section. Since the Tables already include the pre-calculated increases for sprinklers the increase indicated in Section 510.5 is lost in the translation. This proposal clarifies what the increases are in Section 510.5 and creates consistency with the height and story increases that were previously specified in Section 504.2 of the 2012 IBC. There are no substantive changes from the original provisions of Section 504.2 of the 2012 IBC proposed.

Cost Impact

The code change proposal will not increase or decrease the cost of construction .

This is a correction to add clarity in the code. It will not impact the cost of construction.

Internal ID: 1127

G99-18

IBC: 510.8

Proponent: David Collins, The American Institute of Architects, representing The American Institute of Architects (dcollins@preview-group.com)

2018 International Building Code

Revise as follows:

510.8 Group B or M buildings with Group S-2 open parking garage above. Group B or M occupancies located below a Group S-2 *open parking garage* of a lesser type of construction shall be considered as a separate and distinct building from the Group S-2 *open parking garage* for the purpose of determining the type of construction where all of the following conditions are met:

1. The buildings are separated with a *horizontal assembly* having a *fire-resistance rating* of not less than 2 hours.
2. The occupancies in the building below the *horizontal assembly* are limited to Groups B and M.
3. The occupancy above the *horizontal assembly* is limited to a Group S-2 *open parking garage*.
4. The building below the *horizontal assembly* is of Type IA construction.

Exception: The building below the *horizontal assembly* shall be permitted to be of Type IB or II construction, but not less than the type of construction required for the Group S-2 *open parking garage* above, where the building below is not greater than *one story* in height above grade plane.

5. The height and area of the building below the *horizontal assembly* does not exceed the limits set forth in Section 503.
6. The height and area of the Group S-2 *open parking garage* does not exceed the limits set forth in Section 406.5. The height, in both feet and *stories*, of the Group S-2 *open parking garage* shall be measured from *grade plane* and shall include the building below the *horizontal assembly*.
7. Exits serving the Group S-2 open parking garage discharge directly shall discharge at grade with direct and unobstructed access to a street or public way and are separated from the building below the *horizontal assembly* by 2-hour *fire barriers* constructed in accordance with Section 707 or 2-hour horizontal assemblies constructed in accordance with Section 711, or both.

Reason:

This section requires discharge from the parking garage directly to a street or public way which seems overly restrictive. This will allow an unobstructed path to be used to get access to the street or public way.

Cost Impact

The code change proposal will decrease the cost of construction .

The ambiguity in the code should be reduced by this change that will save money in the design of buildings, as well as the review and approval process.

Internal ID: 1751

G100-18

IBC: 602.1, 602.2 (New), 602.2.1, 602.2.2, 602.2.3, , 602.2.4, 602.3 (New), , 602.3.1, 602.3.2, 602.3.3

Proponent: Gregory Keith, representing The Boeing Company (grkeith@mac.com)

2018 International Building Code

602.1 General. Buildings and structures erected or to be erected, altered or extended in height or area shall be classified in one of the five construction types defined in Sections ~~602.2-602.2.1~~ through ~~602.5-602.2.4~~. The building elements shall have a *fire-resistance rating* not less than that specified in Table 601 ~~and exterior and shall be constructed of materials as required by Sections 602.2 and 602.3 for the applicable type of construction.~~ Exterior walls shall have a *fire-resistance rating* not less than that specified in Table 602. Where required to have a *fire-resistance rating* by Table 601, building elements shall comply with the applicable provisions of Section 703.2. The protection of openings, ducts and air transfer openings in building elements shall not be required unless required by other provisions of this code.

602.2 Building element construction materials. Building elements listed in Table 601 shall be constructed of materials in accordance with the provisions of this section.

~~602.2.1~~ **Types I and II construction.** All building elements in buildings of Types I and II construction are those types of construction in which the building elements listed in Table 601 are of noncombustible materials, except as permitted in Section 603 and elsewhere in this code shall be constructed of noncombustible materials.

Exception: Combustible materials are permitted to be used as listed below and elsewhere in this code.

1. Fire-retardant-treated wood framing complying with Section 2303.2 shall be permitted as follows:
 - 1.1. Nonbearing partitions where the required fire-resistance rating is 2 hours or less.
 - 1.2. Nonbearing exterior walls where fire-resistance rated construction is not required.
 - 1.3. Roof construction, including girders, trusses, framing and decking. In buildings of Type IA construction exceeding two stories above grade plane, fire-retardant-treated wood is not permitted in roof construction where the vertical distance from the upper floor to the roof is less than 20 feet (6096 mm).
2. Partitions dividing portions of stores, offices or similar places occupied by one tenant only and that do not establish a corridor serving an occupant load of 30 or more shall be permitted to be constructed of fire-retardant-treated wood, 1-hour fire-resistance-rated construction or of wood panels or similar light construction up to 6 feet (1829 mm) in height.
3. Stages and platforms constructed in accordance with Sections 410.3 and 410.4, respectively.
4. Wall construction of freezers and coolers of less than 1000 square feet (92.9 m²), in size, lined on both sides with noncombustible materials where the building is protected throughout with an automatic sprinkler system in accordance with Section 903.3.1.1.

Materials used on or within building elements in buildings of Type I or II construction shall comply with Section 602.3.

~~602.3~~ **602.2.2 Type III construction.** Exterior walls in buildings of Type III construction is that type of construction in which the exterior walls are of noncombustible materials and the interior building elements are of any material permitted by this code shall be constructed of materials complying with Section 602.2.1.

Exception:  Fire-retardant-treated wood framing and sheathing complying with Section 2303.2 shall be permitted within exterior wall assemblies of having a 2-hour fire-resistance-rating or less. Interior building elements in buildings of Type III construction shall be of any material permitted by this code.



~~602.4~~ **602.2.3 Type IV (Heavy Timber, HT) construction.** Exterior walls in buildings of Type IV construction is that type of construction in which the exterior walls are of noncombustible materials and the interior building elements are (Heavy Timber, HT) construction shall be constructed of materials complying with Section 602.2.1.

Exceptions:

1. Fire-retardant-treated wood framing and sheathing complying with Section 2303.2 shall be permitted within exterior wall assemblies not less than 6 inches (152 mm) in thickness and having a fire-resistance rating of 2-hours or less.
2. Cross-laminated timber complying with Section 2303.1.4 shall be permitted within exterior wall

assemblies not less than 6 inches (152 mm) in thickness and having a 2-hour fire-resistance rating or less, provided the exterior surface of the cross-laminated timber is protected by one the following:

- 2.1. Fire-retardant-treated wood sheathing complying with Section 2303.2 and not less than $\frac{15}{32}$ inch (12 mm) thick;
 - 2.2. Gypsum board not less than $\frac{1}{2}$ inch (12.7 mm) thick; or
 - 2.3. A noncombustible material.
3. Where a fire separation distance of 20 feet (6096 mm) or more is provided, wood columns and arches conforming to heavy timber sizes complying with Section 2304.11 shall be permitted.

Interior building elements shall be of solid wood, laminated wood, heavy timber (HT) or structural composite lumber (SCL) without concealed spaces. The minimum dimensions for permitted materials including solid timber, glued-laminated timber, structural composite lumber (SCL), and cross-laminated timber and details of Type IV construction shall comply with the provisions of this section and Section 2304.11. Exterior walls complying with Section 602.4.1 or 602.4.2 shall be permitted.

Exception: Interior walls and partitions having not less than a 1-hour fire-resistance rating or heavy timber complying with Section 2304.11.2.2 shall be permitted.

~~**602.4.1 Fire-retardant-treated wood in exterior walls.** *Fire-retardant treated wood framing and sheathing complying with Section 2303.2 shall be permitted within exterior wall assemblies not less than 6 inches (152 mm) in thickness with a 2-hour rating or less.*~~

~~**602.4.2 Cross-laminated timber in exterior walls.** *Cross-laminated timber complying with Section 2303.1.4 shall be permitted within exterior wall assemblies not less than 6 inches (152 mm) in thickness with a 2-hour rating or less, provided the exterior surface of the cross-laminated timber is protected by one the following:*~~

- ~~1. *Fire-retardant-treated wood sheathing complying with Section 2303.2 and not less than $\frac{15}{32}$ inch (12 mm) thick;*~~
- ~~2. *Gypsum board not less than $\frac{1}{2}$ inch (12.7 mm) thick; or*~~
- ~~3. *A noncombustible material.*~~

~~**602.4.3 Exterior structural members.** *Where a horizontal separation of 20 feet (6096 mm) or more is provided, wood columns and arches conforming to heavy timber sizes complying with Section 2304.11 shall be permitted to be used externally.*~~

~~**602.5602.2.4 Type V-V construction.** *All building elements in buildings of Type V construction is that type of construction in which the structural elements, exterior walls and interior walls are shall be constructed of any materials permitted by this code.*~~

602.3 Materials used on or within building elements. All construction materials used on or within building elements listed in Table 601 for buildings of Type I or II construction and exterior walls in Type III or IV (HT) construction shall be noncombustible, except that combustible materials are permitted to be used as listed below and elsewhere in this code.

1. Blocking such as for handrails, millwork, cabinets and window and door frames.
2. Millwork such as doors, door frames, window sashes and frames.
3. Trim installed in accordance with Section 806.
4. Nailing or furring strips in accordance with Section 803.15.
5. Where not installed greater than 15 feet (4572 mm) above grade, show windows, nailing or furring strips and wooden bulkheads below show windows, including their frames, aprons and show cases.
6. Combustible exterior wall coverings, balconies and similar projections and bay or oriel windows in accordance with Chapter 14 and Section 705.2.3.1.
7. Exterior plastic veneer installed in accordance with Section 2605.2.
8. Interior wall and ceiling finishes installed in accordance with Section 803.

9. Interior floor finish and floor covering materials installed in accordance with Section 804.
10. Finish flooring installed in accordance with Section 805.
11. Roof coverings that have an A, B or C classification.
12. Heavy timber as permitted by Note c to Table 601 and Sections 602.4.3 and 705.2.3.1.
13. Thermal and acoustical insulation, other than foam plastics, having a flame spread index of not more than 25.

Exceptions:

1. Insulation placed between two layers of noncombustible materials without an intervening airspace shall be allowed to have a flame spread index of not more than 100.
 2. Insulation installed between a finished floor and solid decking without intervening airspace shall be allowed to have a flame spread index of not more than 200.
14. Foam plastics in accordance with Chapter 26.
 15. Light-transmitting plastics as permitted by Chapter 26.
 16. Mastics and caulking materials applied to provide flexible seals between components of exterior wall construction.
 17. Aggregates, component materials and admixtures as permitted by Section 703.2.2.
 18. Sprayed fire-resistant materials and intumescent and mastic fire-resistant coatings, determined on the basis of fire-resistance tests in accordance with Section 703.2 and installed in accordance with Sections 1705.14 and 1705.15 respectively.
 19. Materials used to protect penetrations in fire-resistance-rated assemblies in accordance with Section 714.
 20. Materials used to protect joints in fire-resistance-rated assemblies in accordance with Section 715.
 21. Materials allowed in the concealed spaces of buildings of Types I and II construction in accordance with Section 718.5.
 22. Materials exposed within plenums complying with Section 602 of the International Mechanical Code.
 23. Wall construction of freezers and coolers of less than 1,000 square feet (92.9 m²), in size, lined on both sides with noncombustible materials and the building is protected throughout with an automatic sprinkler system in accordance with Section 903.3.1.1.

SECTION 603 COMBUSTIBLE MATERIAL IN TYPES I AND II CONSTRUCTION

603.1 Allowable materials. Combustible materials shall be permitted in buildings of Type I or II construction in the following applications and in accordance with Sections 603.1.1 through 603.1.3:

1. *Fire-retardant-treated wood* shall be permitted in:
 - 1.1: *Nonbearing partitions where the required fire-resistance rating is 2 hours or less.*
 - 1.2: *Nonbearing exterior walls where fire-resistance-rated construction is not required.*
 - 1.3: *Roof construction, including girders, trusses, framing and decking.*

Exception: In buildings of Type IA construction exceeding two stories above grade plane, *fire-retardant-treated wood* is not permitted in roof construction where the vertical distance from the upper floor to the roof is less than 20 feet (6096 mm).
 - 1.4: *Balconies, porches, decks and exterior stairways not used as required exits on buildings three stories or less above grade plane.*
2. Thermal and acoustical insulation, other than foam plastics, having a *flame spread index* of not more than 25:

Exceptions:

1. Insulation placed between two layers of noncombustible materials without an intervening airspace shall be allowed to have a *flame spread index* of not more than 100.
2. Insulation installed between a finished floor and solid decking without intervening airspace shall be allowed to have a *flame spread index* of not more than 200.

3. ~~Foam plastics in accordance with Chapter 26.~~
4. ~~Roof coverings that have an A, B or C classification.~~
5. ~~Interior floor finish and floor covering materials installed in accordance with Section 804.~~
6. ~~Millwork such as doors, door frames, window sashes and frames.~~
7. ~~Interior wall and ceiling finishes installed in accordance with Section 803.~~
8. ~~Trim installed in accordance with Section 806.~~
9. ~~Where not installed greater than 15 feet (4572 mm) above grade, show windows, nailing or furring strips and wooden bulkheads below show windows, including their frames, aprons and show cases.~~
10. ~~Finish flooring installed in accordance with Section 805.~~
11. ~~Partitions dividing portions of stores, offices or similar places occupied by one tenant only and that do not establish a corridor serving an occupant load of 30 or more shall be permitted to be constructed of fire-retardant-treated wood, 1-hour fire-resistance-rated construction or of wood panels or similar light construction up to 6 feet (1829 mm) in height.~~
12. ~~Stages and platforms constructed in accordance with Sections 410.2 and 410.3, respectively.~~
13. ~~Combustible exterior wall coverings, balconies and similar projections and bay or oriel windows in accordance with Chapter 14 and Section 705.2.3.1.~~
14. ~~Blocking such as for handrails, millwork, cabinets and window and door frames.~~
15. ~~Light-transmitting plastics as permitted by Chapter 26.~~
16. ~~Mastics and caulking materials applied to provide flexible seals between components of exterior wall construction.~~
17. ~~Exterior plastic veneer installed in accordance with Section 2605.2.~~
18. ~~Nailing or furring strips as permitted by Section 803.15.~~
19. ~~Heavy timber as permitted by Note c to Table 601 and Sections 602.4.3 and 705.2.3.1.~~
20. ~~Aggregates, component materials and admixtures as permitted by Section 703.2.2.~~
21. ~~Sprayed fire-resistant materials and intumescent and mastic fire-resistant coatings, determined on the basis of fire resistance tests in accordance with Section 703.2 and installed in accordance with Sections 1705.14 and 1705.15, respectively.~~
22. ~~Materials used to protect penetrations in fire-resistance-rated assemblies in accordance with Section 714.~~
23. ~~Materials used to protect joints in fire-resistance-rated assemblies in accordance with Section 715.~~
24. ~~Materials allowed in the concealed spaces of buildings of Types I and II construction in accordance with Section 718.5.~~
25. ~~Materials exposed within plenums complying with Section 602 of the International Mechanical Code.~~
26. ~~Wall construction of freezers and coolers of less than 1,000 square feet (92.9 m²), in size, lined on both sides with noncombustible materials and the building is protected throughout with an automatic sprinkler system in accordance with Section 903.3.1.1.~~

~~603.1-1602.3.1 Ducts.~~ The use of nonmetallic ducts shall be permitted where installed in accordance with the limitations of the International Mechanical Code.

~~603.1-2602.3.2 Piping.~~ The use of combustible piping materials shall be permitted where installed in accordance with the limitations of the International Mechanical Code and the International Plumbing Code.

~~603.1-3602.3.3 Electrical.~~ The use of electrical wiring methods with combustible insulation, tubing, raceways and related components shall be permitted where installed in accordance with the limitations of this code.

Reason:

During the last code development cycle the ICC Building Code Action Committee (BCAC) submitted a proposal that reorganized the combustible materials allowances presently contained in Section 603.1. The General Code Committee disapproved the proposal. The published statement explaining the committee action included, "the committee appreciated the effort to reorganize these provisions, but there were concerns that it was incomplete."

The Boeing Company agreed with the concept, but felt that the proposal was not as comprehensive as it should be.

Boeing rewrote the proposal and submitted it as a public comment. The public comment was approved by a 2/3 majority of those voting members in attendance at the public comment hearings. Subsequent to that action it was discovered that an exception relating to the use of fire-retardant materials in Type III buildings had been omitted. The Boeing Company contacted voting members to urge them to vote for disapproval of the public comment during the remote voting phase. The public comment was disapproved as a final action.

Based on the positive reaction to the concept of the public comment, a similar proposal is being submitted for this code development cycle. Necessarily, the proposal is updated so as to be based on 2018 IBC provisions. The major flaw with the BCAC proposal was that it redistributed the current items at Section 603.1 throughout the code. Although many dislike "laundry lists," in this case a "one stop shop" for the various combustible construction materials allowances greatly benefits building designers and code enforcement officials alike.

This proposal accomplishes two things. It rewords Section 602 provisions so that the construction materials provisions are easily understood. Currently, several provisions that represent exceptions to the base requirement for noncombustible materials are contained within the text. Those allowances are now appropriately identified as exceptions. Secondly, the proposal reorganizes the Section 603.1 items in a hierarchy based on their likelihood of use.

The provision is largely editorial. Some language has been clarified for functionality. For instance, current Section 602.4.3 states, "Where a horizontal separation of 20 feet or more is provided,..." Horizontal separation is a nebulous term with no defined end points. That term has been replaced by the more appropriate term "fire separation distance." Also, currently Section 603.1 indicates that the following items are applicable to Types I and II construction.

Literally interpreted, this would not allow for those items applicable to exterior wall construction to be permitted in buildings of Type III and IV construction. This proposal corrects that oversight.

What follows is a listing of the former and proposed locations for each of the Section 603.1 items.

<u>Former Section 603.1</u>	<u>Proposed Location</u>
1.)	602.2.1, Item 1
2.)	602.3, Item 13
3.)	602.3, Item 14
4.)	602.3, Item 11
5.)	602.3, Item 9
6.)	602.3, Item 2
7.)	602.3, Item 8
8.)	602.3, Item 3
9.)	602.3, Item 5
10.)	602.3, Item 10
11.)	602.2.1, Item 2
12.)	602.2.1, Item 3
13.)	602.3, Item 6
14.)	602.3, Item 1
15.)	602.3, Item 15
16.)	602.3, Item 16
17.)	602.3, Item 7
18.)	602.3, Item 4
19.)	602.3, Item 12
20.)	602.3, Item 17
21.)	602.3, Item 18
22.)	602.3, Item 19
23.)	602.3, Item 20
24.)	602.3, Item 21
25.)	602.3, Item 22
26.)	602.2.1, Item 4

This proposal essentially represents an overhaul of the Sections 602 and 603 construction materials provisions.

Approval of this proposal will result in more uniform interpretations of these fundamental code provisions by providing users with requirements that are in technical context with their given application based on the specific type of construction, exterior or interior wall, etc.

Cost Impact

The code change proposal will not increase or decrease the cost of construction .

This is essentially an editorial revision that changes no current requirements.

Internal ID: 1577

G101-18

IBC: TABLE 601

Proponent: Homer Maiel, representing ICC Tri-Chapter (Peninsula, East Bay, Monterey Bay) (hmaiel@gmail.com)

2018 International Building Code

Revise as follows:

**TABLE 601
FIRE-RESISTANCE RATING REQUIREMENTS FOR BUILDING ELEMENTS (HOURS)**

BUILDING ELEMENT	TYPE I		TYPE II		TYPE III		TYPE IV	TYPE V	
	A	B	A	B	A	B	HT	A	B
Primary structural frame ^f (see Section 202)	3 ^{a, b}	2 ^{a, b}	1 ^b	0	1 ^b	0	HT	1 ^b	0
Bearing walls Exterior ^{e, f} Interior	3 3 ^a	2 2 ^a	1 1 ^a	0 0	2 1	2 0	2 1/HT ^g	1 1	0 0
Nonbearing walls and partitions Exterior	See Table 602								
Nonbearing walls and partitions Interior ^d	0	0	0	0	0	0	See Section 2304.11.2	0	0
Floor construction and associated secondary members (see Section 202)	2	2	1	0	1	0	HT	1	0
Roof construction and associated secondary members (see Section 202)	1 ^{1/2} ^b	1 ^{b, c}	1 ^{b, c}	0 ^c	1 ^{b, c}	0	HT	1 ^{b, c}	0

For SI: 1 foot = 304.8 mm.

- a. Roof supports: Fire-resistance ratings of primary structural frame and bearing walls are permitted to be reduced by 1 hour where supporting a roof only.
- b. Except in Group F-1, H, M and S-1 occupancies, fire protection of structural members in roof construction shall not be required, including protection of primary structural frame members, roof framing and decking where every part of the roof construction is 20 feet or more above any floor immediately below. Fire-retardant-treated wood members shall be allowed to be used for such unprotected members.
- c. In all occupancies, heavy timber complying with Section 2304.11 shall be allowed where a 1-hour or less fire-resistance rating is required.
- d. Not less than the fire-resistance rating required by other sections of this code.
- e. Not less than the fire-resistance rating based on fire separation distance (see Table 602).
- f. Not less than the fire-resistance rating as referenced in Section 704.10.
- g. Heavy timber bearing walls supporting more than two floors or more than a floor and a roof shall have a fire resistance rating of not less than 1 hour.

Reason:

Cross laminated timber was introduced into the 2015 IBC. Section 2304.11.2.2 and table 601 permit 4 inch heavy timber walls that do not have a fire resistance rating to serve as bearing walls in structures that could be as many as 6 stories tall for a group B occupancy building. Generally heavy timber dimensions for vertical elements result in building elements that have a fire resistance rating in the ballpark of 45 minutes to 1 hour or more. CLT walls as thin as 4 inches can support the tributary loads from floors of 5 stories but when a 4 inch thick CLT wall is fully loaded and exposed without protection, it may have an intrinsic structural fire resistance rating of less than 30 minutes. This is not a problem for columns because they tend to grow bigger with a commensurate intrinsic fire resistance as buildings get taller.

This proposal modifies Table 601 to require heavy timber bearing walls supporting more than two floors or a floor and a roof to be of 1-hour fire resistance rating or greater which is appropriate for vertical elements in mid-rise multi-story buildings. If a designer desires to have an exposed CLT bearing wall supporting multiple stories they may need to increase the thickness of the wall to provide 1 hour fire resistance rating. This may be calculated in accordance with Chapter 16 of the National Design Specification as allowed in Section 722.1 or they may need to utilize a tested wall.

Cost Impact

The code change proposal will increase the cost of construction .

This proposal will increase the cost of construction in certain instances of tall non-residential Type IV buildings. This proposal will not increase the cost of construction for Type IV residential occupancy groups because Section 420, Section 508.3.3 exception 2, and Section 711 already require bearing walls of Type IV construction to be a minimum of one hour fire resistance rated for R occupancy groups with no exceptions for sprinklers.

Internal ID: 1960

G102-18

IBC: TABLE 601

Proponent: Dennis Richardson, American Wood Council, representing American Wood Council (drichardson@awc.org)

2018 International Building Code

Revise as follows:

**TABLE 601
FIRE-RESISTANCE RATING REQUIREMENTS FOR BUILDING ELEMENTS (HOURS)**

BUILDING ELEMENT	TYPE I		TYPE II		TYPE III		TYPE IV	TYPE V	
	A	B	A	B	A	B	HT	A	B
Primary structural frame ^f (see Section 202)	3 ^{a, b}	2 ^{a, b, c}	1 ^{b, c}	0 ^c	1 ^{b, c}	0	HT	1 ^{b, c}	0
Bearing walls Exterior ^{e, f} Interior	3 3 ^a	2 2 ^a	1 1	0 0	2 1	2 0	2 1/HT	1 1	0 0
Nonbearing walls and partitions Exterior	See Table 602								
Nonbearing walls and partitions Interior ^d	0	0	0	0	0	0	See Section 2304.11.2	0	0
Floor construction and associated secondary members (see Section 202)	2	2	1	0	1	0	HT	1	0
Roof construction and associated secondary members (see Section 202)	1 ^{1/2} ^b	1 ^{b, c}	1 ^{b, c}	0 ^c	1 ^{b, c}	0	HT	1 ^{b, c}	0

For SI: 1 foot = 304.8 mm.

- a. Roof supports: Fire-resistance ratings of primary structural frame and bearing walls are permitted to be reduced by 1 hour where supporting a roof only.
- b. Except in Group F-1, H, M and S-1 occupancies, fire protection of structural members in roof construction shall not be required, including protection of primary structural frame members, roof framing and decking where every part of the roof construction is 20 feet or more above any floor immediately below. Fire-retardant-treated wood members shall be allowed to be used for such unprotected members.
- c. In all occupancies, heavy timber complying with Section 2304.11 shall be allowed for roof construction, including primary structural frame members, where a 1-hour or less fire-resistance rating is required.
- d. Not less than the fire-resistance rating required by other sections of this code.
- e. Not less than the fire-resistance rating based on fire separation distance (see Table 602).
- f. Not less than the fire-resistance rating as referenced in Section 704.10.

Reason:

The exception in footnote **c** for using heavy timber in roof construction has in the past been applied to all roof elements, including those that may fit within the definition of Primary Structural Frame, which came into the code later. However, some code officials have not permitted the use of footnote **c** for roof members that fit the definition of primary structural frame, since there is a separate row for primary structural frame in the table. We believe the correct interpretation is to allow the footnote to apply to all roof construction, including structural members that are part of the primary structural frame.

In the last cycle, a similar phrase, “including protection of primary structural frame members” and the qualifier “in roof construction” was approved for footnote **b**, which permits roof construction, including roof members that are part of the primary structural frame, to be unprotected when every part of the roof construction is more than 20 feet above the floor below (G167-15, AS). In a similar manner, this code change will clarify that footnote **c** is intended to permit all roof construction with a required rating of one hour or less to be heavy timber.

Cost Impact

The code change proposal will not increase or decrease the cost of construction .

This code change clarifies interpretation of existing language giving more options to designers. Because of that it will not increase or decrease the cost of construction.

Internal ID: 1787

G103-18

IBC: 202, TABLE 601, 704.4

Proponent: Ed Kullik, Chair, representing ICC Building Code Action Committee (bcac@iccsafe.org); Michael O'Brian, Chair, representing FCAC (fcac@iccsafe.org)

2018 International Building Code

Revise as follows:

[BG] PRIMARY STRUCTURAL FRAME. The primary structural frame shall include all of the following structural members:

1. The columns.
2. Structural members having direct connections to the columns, including girders, beams, trusses and spandrels.
3. Members of the floor construction and roof construction having direct connections to the columns.
4. ~~Bracing members—Members that are essential to the vertical stability of the primary structural frame under gravity loading shall be considered part of the primary structural frame whether or not the bracing member carries gravity loads.~~loading.

[BG] SECONDARY STRUCTURAL MEMBERS. The following structural members shall be considered secondary members and not part of the primary structural frame:

1. Structural members not having direct connections to the columns.
2. Members of the floor construction and roof construction not having direct connections to the columns.
3. Bracing members ~~other than those that are~~ not designated as part of the a primary structural frame of bearing wall.

**TABLE 601
FIRE-RESISTANCE RATING REQUIREMENTS FOR BUILDING ELEMENTS (HOURS)**

BUILDING ELEMENT	TYPE I		TYPE II		TYPE III		TYPE IV	TYPE V	
	A	B	A	B	A	B	HT	A	B
Primary structural frame ^f (see Section 202)	3 ^{a, b}	2 ^{a, b}	1 ^b	0	1 ^b	0	HT	1 ^b	0
Bearing walls Exterior ^{e, f} Interior	3 3 ^a	2 2 ^a	1 1	0 0	2 1	2 0	2 1/HT	1 1	0 0
Nonbearing walls and partitions Exterior	See Table 602								
Nonbearing walls and partitions Interior ^d	0	0	0	0	0	0	See Section 2304.11.2	0	0
Floor construction and associated secondary structural members (see Section 202)	2	2	1	0	1	0	HT	1	0
Roof construction and associated secondary structural members (see Section 202)	1 ^{1/2} ^b	1 ^{b, c}	1 ^{b, c}	0 ^c	1 ^{b, c}	0	HT	1 ^{b, c}	0

For SI: 1 foot = 304.8 mm.

- a. Roof supports: Fire-resistance ratings of primary structural frame and bearing walls are permitted to be reduced by 1 hour where supporting a roof only.
- b. Except in Group F-1, H, M and S-1 occupancies, fire protection of structural members in roof construction shall not be required, including protection of primary structural frame members, roof framing and decking where every part of the roof construction is 20 feet or more above any floor immediately below. Fire-retardant-treated wood members shall be allowed to be used for such unprotected members.
- c. In all occupancies, heavy timber complying with Section 2304.11 shall be allowed where a 1-hour or less fire-resistance rating is required.
- d. Not less than the fire-resistance rating required by other sections of this code.
- e. Not less than the fire-resistance rating based on fire separation distance (see Table 602).
- f. Not less than the fire-resistance rating as referenced in Section 704.10.

704.4 Protection of secondary structural members. Secondary structural members that are required to have protection to achieve a *fire-resistance rating* shall be protected by individual encasement protection.

Reason:

The definitions for the terms “primary structural frame” and “secondary members” are proposed to be modified so as to:

- update the terms to adequately address new technologies,
- to remove parts of the definition which could be considered archaic, and
- to remove what was viewed as redundant language.

The new technologies being addressed is mass timber (e.g. glu-laminated, structural composite, cross laminated). The proposed cleanup of this language will allow designers and code officials to better identify the structural characteristics, such as when an entire building is constructed of mass timber panels (e.g. no columns). This will also benefit the same parties when other new materials technologies enter the market.

The proposal focuses on modifying the “bracing members” subcategories where over time with modifications the current language has become difficult to distinguish between the two. One example being when a lateral support member does not act as an element that part of the vertical stability of the structure, what is it? When reviewed multiple responses were received suggesting the language in the definitions needed greater clarity.

The proposal also have removed language from “Primary Structural Frame” that was felt to be redundant (e.g. the term “bracing”)

These terms are used in Chapter 6 “Types of Construction,” Chapter 7 “Smoke and Fire Protection Features,” and Appendix L “Requirements for Fire Fighting Air Replenishing Systems,” and focus on the fire resistance characteristics of those structural elements. These terms are not used in Chapter 16 “Structural” nor the materials chapters of the IBC.

Adding the word “structural” to the term “Secondary structural member” clarifies the intent and link to the definition for “primary structural members”. The word “structural” is also added to the applicable portions of Table 601.

This proposal is submitted by the ICC Building Code Action Committee (BCAC) and the ICC Fire Code Action Committee (FCAC). The BCAC was established by the ICC Board of Directors in July 2011 to pursue opportunities to improve and enhance assigned International Codes or portions thereof. In 2017 the BCAC has held 3 open meetings. In addition, there were numerous Working Group meetings and conference calls for the current code development cycle, which included members of the committee as well as any interested party to discuss and debate the proposed changes. Related documentation and reports are posted on the BCAC website at: <https://www.iccsafe.org/codes-tech-support/codes/code-development-process/building-code-action-committee-bcac>. The FCAC was established by the ICC Board of Directors to pursue opportunities to improve and enhance assigned International Codes with regard to fire safety and hazardous materials in new and existing buildings and facilities and the protection of life and property in wildland urban interface areas. In 2017 the Fire-CAC has held 3 open meetings. In addition, there were numerous conference calls, Regional Work Group and Task Group meetings for the current code development cycle, which included members of the committees as well as any interested parties, to discuss and debate the proposed changes. Related documentation and reports are posted on the FCAC website at: <https://www.iccsafe.org/codes-tech-support/cs/fire-code-action-committee-fcac/>.

Cost Impact

The code change proposal will not increase or decrease the cost of construction .

This proposal represents a clarification of the definitions to more clearly align with the original intent of the terms.

G104-18

IBC: TABLE 601

Proponent: Andrew Klein, representing Self Storage Association (andrew@asklein.com)

2018 International Building Code

Revise as follows:

**TABLE 601
FIRE-RESISTANCE RATING REQUIREMENTS FOR BUILDING ELEMENTS (HOURS)**

BUILDING ELEMENT	TYPE I		TYPE II		TYPE III		TYPE IV HT	TYPE V	
	A	B	A ^a	B	A ^a	B		A ^a	B
Primary structural frame ^f (see Section 202)	3 ^{a, b}	2 ^{a, b}	1 ^b	0	1 ^b	0	HT	1 ^b	0
Bearing walls Exterior ^{e, f} Interior	3 3 ^a	2 2 ^a	1 1	0 0	2 1	2 0	2 1/HT	1 1	0 0
Nonbearing walls and partitions Exterior	See Table 602								
Nonbearing walls and partitions Interior ^d	0	0	0	0	0	0	See Section 2304.11.2	0	0
Floor construction and associated secondary members (see Section 202)	2	2	1	0	1	0	HT	1	0
Roof construction and associated secondary members (see Section 202)	1 ^{1/2} ^b	1 ^{b, c}	1 ^{b, c}	0 ^c	1 ^{b, c}	0	HT	1 ^{b, c}	0

For SI: 1 foot = 304.8 mm.

- a. Roof supports: Fire-resistance ratings of primary structural frame and bearing walls are permitted to be reduced by 1 hour where supporting a roof only.
- b. Except in Group F-1, H, M and S-1 occupancies, fire protection of structural members in roof construction shall not be required, including protection of primary structural frame members, roof framing and decking where every part of the roof construction is 20 feet or more above any floor immediately below. Fire-retardant-treated wood members shall be allowed to be used for such unprotected members.
- c. In all occupancies, heavy timber complying with Section 2304.11 shall be allowed where a 1-hour or less fire-resistance rating is required.
- d. Not less than the fire-resistance rating required by other sections of this code.
- e. Not less than the fire-resistance rating based on fire separation distance (see Table 602).
- f. Not less than the fire-resistance rating as referenced in Section 704.10.
- g. Except in Group H, I and R occupancies where an automatic sprinkler system in accordance with Section 903.3.1.1 is required by Section 903.2, such system shall be allowed to be substituted for 1-hour fire-resistance-rated construction provided that the height and tabular allowable area factor of buildings are limited to the values specified in the NS rows of Tables 506.2 and Table 504.3. This substitution shall not be permitted for exterior walls.

Reason:

This proposal reinstates an exception that that was taken out in the 2015 IBC due to concerns over enforcement. It was argued that the previous language, which allowed a reduction in fire resistance ratings when a full NFPA 13 sprinkler system was installed but not needed, could not be accurately enforced because there are so many exceptions and reductions to the provisions of the code that are permitted by the installation of a sprinkler system.

It was further argued that there was no cost increase by taking out the footnote since those projects that are taking the one-hour reduction along with non-allowed trade-offs are non-compliant anyway. The footnote was taken out with the justification that it removed an unnecessary level of complication.

The deletion of the footnote provides a disincentive to sprinkler small buildings where sprinklers are not mandatory. Fire sprinklers are very effective in controlling fires in such buildings. Furthermore, this proposal provides easily enforceable language that is more consistent with the way in which the footnote had been successfully used since the first edition of the IBC and within the UBC legacy code prior to the IBC. Group H, I, and R occupancies that are required to have a full NFPA 13 sprinkler system may not take advantage of this footnote.

Cost Impact

The code change proposal will decrease the cost of construction .

This proposal allows a reduction in the fire-resistance rating of construction in some cases if automatic sprinklers are provided. Because the footnote is optional, it reasonable to assume it only be utilized to take advantage of the cost savings.

Internal ID: 1685

G105-18

IBC: TABLE 602

Proponent: Christopher Athari, Hoover Treated Wood Products, representing Hoover Treated Wood Products (cathari@frtw.com)

2018 International Building Code

Revise as follows:

TABLE 602**FIRE-RESISTANCE RATING REQUIREMENTS FOR EXTERIOR WALLS BASED ON FIRE SEPARATION DISTANCE^a,
d, g**

FIRE SEPARATION DISTANCE =X (feet)	TYPE OF CONSTRUCTION	OCCUPANCY GROUP H^e	OCCUPANCY GROUP F-1, M, S-1^f	OCCUPANCY GROUP A, B, E, F-2, I, Rⁱ, S-2, U^h
X < 5 ^b	All	3	2	1
5 ≤ X < 10	IA	3	2	1
	Others	2	1	1
10 ≤ X < 30	IA, IB	2	1	1 ^c
	IIA, VBA, IIIA	1	0	0
	Others	1	1	1 ^c
X ≥ 30	All	0	0	0

For SI: 1 foot = 304.8 mm.

- a. Load-bearing exterior walls shall also comply with the fire-resistance rating requirements of Table 601.
- b. See Section 706.1.1 for party walls.
- c. Open parking garages complying with Section 406 shall not be required to have a fire-resistance rating.
- d. The fire-resistance rating of an exterior wall is determined based upon the fire separation distance of the exterior wall and the story in which the wall is located.
- e. For special requirements for Group H occupancies, see Section 415.6.
- f. For special requirements for Group S aircraft hangars, see Section 412.3.1.
- g. Where Table 705.8 permits nonbearing exterior walls with unlimited area of unprotected openings, the required fire-resistance rating for the exterior walls is 0 hours.
- h. For a building containing only a Group U occupancy private garage or carport, the exterior wall shall not be required to have a fire-resistance rating where the fire separation distance is 5 feet (1523 mm) or greater.
- i. For a Group R-3 building of Type II-B or Type V-B construction, the exterior wall shall not be required to have a fire-resistance rating where the fire separation distance is 5 feet (1523 mm) or greater.

Reason:

It is inconsistent to require Type IIIB to have one hour fire resistance on the exterior of a wall but permit Type IIB and Type VB to have zero hour rating. Consider:

1. Type IIIB and IIB have the same allowable heights indicating they are considered equivalent. See table 504.3
2. Type IIIB has either small allowable areas or equal to Type IIB indicating they are considered nearly equivalent for protection from fire based on the occupancy. Table 506.2
3. The number of stories permitted for Type IIB and Type IIIB are the same. Exception: I-2 occupancies. See table 504.4
4. Both type IIB and IIIB construction a non-combustible exterior finish or cladding. See section 602.2 and 602.3
5. While no fire rating is assigned, it is recognized that the wall will have a rating less than one hour based on typical construction practices, Type IIIB with zero rating on the exterior side of the wall will perform as well or better than a zero hour rated Type IIB wall.
6. The fire rating from the interior side of a Type IIIB wall will have a two-hour rating or more in all cases. A Type IIB wall from the interior side can have no rating in some cases.

Cost Impact

The code change proposal will not increase or decrease the cost of construction .

It adds an option to the code to include IIIB. All other types of building are not modified, no option is being subtracted and thus I would suggest no cost impact.

If one were building IIB, VB, etc construction prior to code change, they may still do so after the code change. It remains the same. No one will be forced to use IIIB.

Internal ID: 880

G106-18

IBC: 602.3

Proponent: Micah Chappell, representing City of Seattle (micah.chappell@seattle.gov)

2018 International Building Code

Revise as follows:

602.3 Type III. Type III construction is that type of construction in which the exterior walls are of noncombustible materials and the interior building elements are of any material permitted by this code. *Fire-retardant-treated wood* framing and sheathing complying with Section 2303.2 shall be permitted within *exterior wall* assemblies of a 2-hour rating or less. Where a floor or roof assembly creates a membrane penetration in the exterior wall assembly of Type III construction, the materials within the penetration shall be noncombustible or fire-retardant-treated wood framing as permitted by this section.

Reason:

This addition of language provides clarification of what is considered part of the exterior wall assembly of Type III construction. Specifically, assemblies penetrating the exterior wall assembly in Type III construction are considered part of the exterior wall assembly.

Cost Impact

The code change proposal will not increase or decrease the cost of construction .

There is no anticipated cost increase or decrease for this clarification.

Internal ID: 1664

G107-18

IBC: 602.3, 602.4.1, 602.4.2

Proponent: Stephen Skalko, Stephen V. Skalko, P.E. & Associates, LLC, representing Masonry Alliance for Codes and Standards (svskalko@svskalko-pe.com); William Hall, Portland Cement Association, representing Alliance For Concrete Codes and Standards (jhall@cement.org)

2018 International Building Code

Revise as follows:

602.3 Type III. Type III construction is that type of construction in which the exterior walls are of noncombustible materials and the interior building elements are of any material permitted by this code. ~~Nonbearing fire-retardant-treated wood framing within exterior wall assemblies of a 2-hour rating or less less provided the required fire resistance is maintained and the exposed outer and inner faces of such walls are noncombustible.~~

602.4.1 Fire-retardant-treated wood in exterior walls. ~~Fire~~Nonbearing fire-retardant-treated wood with Section 2303.2 shall be permitted within exterior wall assemblies not less than 6-inches in thickness with a 2-hour rating provided the required fire resistance is maintained and the exposed outer and inner faces of such walls are noncombustible.

602.4.2 Cross-laminated timber in exterior walls. Cross-laminated timber complying with Section 2303.1.4 or less, provided the exterior ~~surface and interior surfaces~~ of the cross-laminated timber ~~is~~are protected by one the following and the required fire resistance rating is maintained:

1. ~~Fire-retardant-treated wood sheathing complying with Section 2303.2 and not less than $1\frac{5}{32}$ inch (12 mm) thick;~~
2. Gypsum board not less than $\frac{1}{2}$ inch (12.7 mm) thick; or
3. A noncombustible material.

Reason:

Historically building construction types in older building codes and the previous legacy codes are described based on noncombustible and/or combustible materials utilized in the building structural elements. The construction types range from buildings with no combustible structural framing, to those with noncombustible exterior walls and some combustible structural framing on the interior of the building, to buildings where the majority of the structural framing is combustible. This concept of describing the building construction type based on these combinations of noncombustible and/or combustible materials is reflected in the types of construction found in the International Building Code.

Changes to the building code that allow the use of fire retardant treated wood for Types III and IV construction and cross-laminated lumber for Type IV construction have reduced the clarity in the code that these two types of construction are required to have the exterior load-bearing portions of the structure to be noncombustible materials. This is evident by the requirements in the first sentence to both 602.3 Type III and 602.4 Type IV specifying exterior walls to be noncombustible materials. It is implied, but not as clear by the language in the last sentence of 602.3 for Type III construction and in 602.4.1 and 602.4.2 of Type IV construction, where fire retardant treated wood and cross-laminated lumber are permitted to be used "within" the exterior wall. This term "within" indicates the combustible materials are permitted for use as a component in the exterior wall but the structural exterior wall is still required to be noncombustible.

For Types III and IV construction, the use of fire retardant treated wood (FRTW) in exterior walls of noncombustible construction embodied in the IBC language is presumed to come from the last edition of the Uniform Building Code (UBC). In the 1997 UBC edition, upon which portions of the IBC were based, Section 503.4.3 stated "In Types III and IV construction, approved fire-retardant treated wood framing may be used within the assembly of exterior walls when Table 5-A allows a fire resistive rating of 2-hours or less provided the required fire resistance is maintained and the exposed outer and inner faces of such walls are noncombustible". The 1997 UBC is presumed to be the source of this provision since the last editions of the BOCA National Building Code - NBBC (1996) and the Standard Building Code - SBC (1997) were consistent and did not permit FRTW, whether bearing or non-bearing, in exterior walls of Types III or IV construction.

This change will make clear that the bearing portion of the exterior walls in Types III and IV construction, with FRTW "within" the wall, must be noncombustible to qualify for that type of construction. In addition to the FRTW being "within" the exterior wall, the previous language whereby the fire resistance rating of any exterior wall is maintained and that the exposed outer and inner surfaces of such walls are noncombustible have been included for these and CLT

exterior walls, consistent with the original provisions in the 1997 UBC.

Cost Impact

The code change proposal will not increase or decrease the cost of construction .

There is no cost impact from this change. It only clarifies the intent of the code.

Internal ID: 1588

G108-18

IBC: 202, 602.4, 602.4.1, 602.4.1.1 (New), 604.2.4.1.2(New), 602.4.1.2.1 (New), 602.4.1.3 (New), 602.4.1.4 (New), 602.4.1.5 (New), 602.4.1.6 (New), 602.4.2, 602.4.2.1 (New), 602.4.2.2 (New), 602.4.2.2.1 (New), 602.4.2.2.2 (New), 602.4.2.2.3 (New), 602.4.2.2.4 (New), 602.4.2.3 (New), 602.4.2.4 (New), 602.4.2.5 (New), 602.4.2.6 (New), 602.4.3, 602.4.3.1 (New), 602.4.3.2 (New), 602.4.3.3 (New), 602.4.3.4 (New), 602.4.3.5 (New), 602.4.3.6 (New), 602.4.4(New), , TABLE 601, TABLE 602

Proponent: Stephen DiGiovanni, representing ICC Ad Hoc Committee on Tall Wood Buildings (TWB) (TWB@iccsafe.org)

2018 International Building Code

SECTION 202 DEFINITIONS

Revise as follows:

[BS] WALL, LOAD-BEARING. Any wall meeting either of the following classifications:

1. Any metal or wood stud wall that supports more than 100 pounds per linear foot (1459 N/m) of vertical load in addition to its own weight.
2. Any *masonry* or concrete, or mass timber wall that supports more than 200 pounds per linear foot (2919 N/m) of vertical load in addition to its own weight.

Add new definition as follows:

MASS TIMBER. Structural elements of Type IV construction primarily of solid, built-up, panelized or engineered wood products that meet minimum cross section dimensions of Type IV construction.

NONCOMBUSTIBLE PROTECTION (FOR MASS TIMBER).

Noncombustible material, in accordance with Section 703.5, designed to increase the fire-resistance rating and delay the combustion of mass timber.

Revise as follows:

602.4 Type IV. ~~Type IV construction is that type of construction in which the exterior walls are of noncombustible materials and the interior building elements are of solid wood, laminated wood, heavy timber (HT) or structural composite lumber (SCL) without concealed spaces. The minimum dimensions for permitted materials including solid timber, glued-laminated timber, structural composite lumber (SCL), and cross-laminated timber and details of Type IV construction shall comply with the provisions of this section and Section 2304.11. Exterior walls complying with Section 602.4.1 or 602.4.2 shall be permitted. Interior walls and partitions not less than 1-hour fire-resistance rating or heavy timber complying with Section 2304.11.2.2 shall be permitted.~~

Type IV construction is that type of construction in which the building elements are mass timber or noncombustible materials and have fire resistance ratings in accordance with Table 601. Mass timber elements shall meet the fire resistance rating requirements of this section based on either the fire resistance rating of the noncombustible protection, the mass timber, or a combination of both and shall be determined in accordance with Section 703.2 or 703.3. The minimum dimensions and permitted materials for building elements shall comply with the provisions of this section and Section 2304.11. Mass timber elements of Types IV A, IV B and IV C construction shall be protected with noncombustible protection applied directly to the mass timber in accordance with Sections 602.4.1 through 602.4.3. The time assigned to the noncombustible protection shall be determined in accordance with Section 703.8 and comply with 722.7.

Cross-laminated timber shall be labeled as conforming to the heat performance requirements of Section 6.1.3.4 of DOC PS1 and have no delamination in any specimen, except where occurring at a localized characteristic when permitted in the product standard.

Exterior load-bearing walls and nonload-bearing walls shall be mass timber construction, or shall be of noncombustible construction.

Exception: Exterior load-bearing walls and nonload-bearing walls of Type IV-HT Construction in accordance with Section 602.4.4.

The interior building elements, including nonload-bearing walls and partitions, shall be of mass timber construction or of noncombustible construction.

Exception: Interior building elements and nonload-bearing walls and partitions of Type IV-HT Construction in

accordance with Section 602.4.4.

Combustible concealed spaces are not permitted except as otherwise indicated in Sections 602.4.1 through 602.4.4. Combustible stud spaces within light frame walls of Type IV-HT construction shall not be considered concealed spaces, but shall comply with Section 718.

In buildings of Type IV-A, B, and C, construction with an occupied floor located more than 75 feet above the lowest level of fire department access, up to and including 12 stories or 180 feet above grade plane, mass timber interior exit and elevator hoistway enclosures shall be protected in accordance with Section 602.4.1.2. In buildings greater than 12 stories or 180 feet above grade plane, interior exit and elevator hoistway enclosures shall be constructed of non-combustible materials.

Add new text as follows:

602.4.1 Type IV-A. Building elements in Type IV-A construction shall be protected in accordance with Sections 602.4.1.1 through 602.4.1.6. The required fire resistance rating of noncombustible elements and protected mass timber elements shall be determined in accordance with Section 703.2 or Section 703.3.

602.4.1.1 Exterior protection. The outside face of exterior walls of mass timber construction shall be protected with noncombustible protection with a minimum assigned time of 40 minutes as determined in Section 722.7.1(a). All components of the exterior wall covering, shall be of noncombustible material except water resistive barriers having a peak heat release rate of less than 150kW/m², a total heat release of less than 20 MJ/m² and an effective heat of combustion of less than 18MJ/kg as determined in accordance with ASTM E1354 and having a flame spread index of 25 or less and a smoke-developed index of 450 or less as determined in accordance with ASTM E 84 or UL 723. The ASTM E 1354 test shall be conducted on specimens at the thickness intended for use, in the horizontal orientation and at an incident radiant heat flux of 50 kW/m².

602.4.1.2 Interior protection. Interior faces of all mass timber elements, including the inside faces of exterior mass timber walls and mass timber roofs, shall be protected with materials complying with Section 703.5

602.4.1.2.1 Protection time. Noncombustible protection shall contribute a time equal to or greater than times assigned in Table 722.7.1(a), but not less than 80 minutes. The use of materials and their respective protection contributions listed in Table 722.7.1(b) shall be permitted to be used for compliance with Section 722.7.1.

602.4.1.3 Floors. The floor assembly shall contain a noncombustible material not less than one inch in thickness above the mass timber. Floor finishes in accordance with Section 804 shall be permitted on top of the noncombustible material. The underside of floor assemblies shall be protected in accordance with 602.4.1.2.

602.4.1.4 Roofs. The interior surfaces of roof assemblies shall be protected in accordance with Section 602.4.1.2. Roof coverings in accordance with Chapter 15 shall be permitted on the outside surface of the roof assembly.

602.4.1.5 Concealed spaces. Concealed spaces shall not contain combustibles other than electrical, mechanical, fire protection, or plumbing materials and equipment permitted in plenums in accordance with Section 602 of the International Mechanical Code, and shall comply with all applicable provisions of Section 718. Combustible construction forming concealed spaces shall be protected in accordance with Sections 602.4.1.2.

602.4.1.6 Shafts. Shafts shall be permitted in accordance with Sections 713 and Section 718. Both the shaft side and room side of mass timber elements shall be protected in accordance with Section 602.4.1.2.

602.4.2 Type IV-B. Building elements in Type IV-B construction shall be protected in accordance with Sections 602.4.2.1 through 602.4.2.6. The required fire resistance rating of noncombustible elements or mass timber elements shall be determined in accordance with Section 703.2 or Section 703.3.

602.4.2.1 Exterior protection. The outside face of exterior walls of mass timber construction shall be protected with non-combustible protection with a minimum assigned time of 40 minutes as determined in Section 722.7.1(a). All components of the exterior wall covering shall be of noncombustible material except water resistive barriers having a peak heat release rate of less than 150kW/m², a total heat release of less than 20 MJ/m² and an effective heat of combustion of less than 18MJ/kg as determined in accordance with ASTM E1354, and having a flame spread index of 25 or less and a smoke-developed index of 450 or less as determined in accordance with ASTM E 84 or UL 723. The ASTM E 1354 test shall be conducted on specimens at the thickness intended for use, in the horizontal orientation and at an incident radiant heat flux of 50 kW/m².

602.4.2.2 Interior protection. Interior faces of all mass timber elements, including the inside face of exterior mass timber walls and mass timber roofs, shall be protected, as required by this section, with materials complying with Section 703.5.

602.4.2.2.1 Protection time. Noncombustible protection shall contribute a time equal to or greater than times assigned in Table 722.7.1(a), but not less than 80 minutes. The use of materials and their respective protection contributions listed in Table 722.7.1(b) shall be permitted to be used for compliance with Section 722.7.1.

602.4.2.2.2 Protected area. All interior faces of all mass timber elements shall be protected in accordance with Section 602.4.2.2.1, including the inside face of exterior mass timber walls and mass timber roofs.

Exceptions: Unprotected portions of mass timber ceilings and walls complying with Section 602.4.2.2.4 and the following:

1. Unprotected portions of mass timber ceilings, including attached beams, shall be permitted and shall be limited to an area equal to 20% of the floor area in any dwelling unit or fire area; or
2. Unprotected portions of mass timber walls, including attached columns, shall be permitted and shall be limited to an area equal to 40% of the floor area in any dwelling unit or fire area; or
3. Unprotected portions of both walls and ceilings of mass timber, including attached columns and beams, in any dwelling unit or fire area shall be permitted in accordance with section 602.4.2.2.3.
4. Mass timber columns and beams which are not an integral portion of walls or ceilings, respectively, shall be permitted to be unprotected without restriction of either aggregate area or separation from one another.

602.4.2.2.3 Mixed unprotected areas. In each dwelling unit or fire area, where both portions of ceilings and portions of walls are unprotected, the total allowable unprotected area shall be determined in accordance with Equation 6-1.

$(U_{tc}/U_{ac}) + (U_{tw}/U_{aw}) \leq 1$ (Equation 6-1) where:

U_{tc} = Total unprotected mass timber ceiling areas

U_{ac} = Allowable unprotected mass timber ceiling area conforming to Section 602.4.2.2.2, Exception 1

U_{tw} = Total unprotected mass timber wall areas

U_{aw} = Allowable unprotected mass timber wall area conforming to Section 602.4.2.2.2, Exception 2

602.4.2.2.4 Separation distance between unprotected mass timber elements. In each dwelling unit or fire area, unprotected portions of mass timber walls and ceilings shall be not less than 15 feet from unprotected portions of other walls and ceilings, measured horizontally along the ceiling and from other unprotected portions of walls measured horizontally along the floor.

602.4.2.3 Floors. The floor assembly shall contain a noncombustible material not less than one inch in thickness above the mass timber. Floor finishes in accordance with Section 804 shall be permitted on top of the noncombustible material. The underside of floor assemblies shall be protected in accordance with Section 602.4.1.2.

602.4.2.4 Roofs. The interior surfaces of roof assemblies shall be protected in accordance with 602.4.2.2 except, in nonoccupiable spaces, they shall be treated as a concealed space with no portion left unprotected. Roof coverings in accordance with Chapter 15 shall be permitted on the outside surface of the roof assembly.

602.4.2.5 Concealed spaces. Concealed spaces shall not contain combustibles other than electrical, mechanical, fire protection, or plumbing materials and equipment permitted in plenums in accordance with Section 602 of the International Mechanical Code, and shall comply with all applicable provisions of Section 718. Combustible construction forming concealed spaces shall be protected in accordance with Section 602.4.1.2.

602.4.2.6 Shafts. Shafts shall be permitted in accordance with Section 713 and Section 718. Both the shaft side and room side of mass timber elements shall be protected in accordance with Section 602.4.1.2.

602.4.3 Type IV-C. Building elements in Type IV-C construction shall be protected in accordance with Sections 602.4.3.1 through 602.4.3.6. The required fire resistance rating of building elements shall be determined in accordance with Section 703.2 or Section 703.3.

602.4.3.1 Exterior protection. The exterior side of walls of combustible construction shall be protected with non-

combustible protection with a minimum assigned time of 40 minutes as determined in Section 722.7.1(a). All components of the exterior wall covering, shall be of noncombustible material except water resistive barriers having a peak heat release rate of less than 150kW/m², a total heat release of less than 20 MJ/m² and an effective heat of combustion of less than 18MJ/kg as determined in accordance with ASTM E1354 and having a flame spread index of 25 or less and a smoke-developed index of 450 or less as determined in accordance with ASTM E 84 or UL 723. The ASTM E 1354 test shall be conducted on specimens at the thickness intended for use, in the horizontal orientation and at an incident radiant heat flux of 50 kW/m².

602.4.3.2 Interior protection. Mass timber elements are permitted to be unprotected.

602.4.3.3 Floors. Floor finishes in accordance with Section 804 shall be permitted on top of the floor construction.

602.4.3.4 Roofs. Roof coverings in accordance with Chapter 15 shall be permitted on the outside surface of the roof assembly.

602.4.3.5 Concealed spaces. Concealed spaces shall not contain combustibles other than electrical, mechanical, fire protection, or plumbing materials and equipment permitted in plenums in accordance with Section 602 of the International Mechanical Code, and shall comply with all applicable provisions of Section 718. Combustible construction forming concealed spaces shall be protected with noncombustible protection with a minimum assigned time of 40 minutes as determined in Section 722.7.1(a).

602.4.3.6 Shafts. Shafts shall be permitted in accordance with Section 713 and Section 718. Shafts and elevator hoistway and interior exit stairway enclosures shall be protected with noncombustible protection with a minimum assigned time of 40 minutes as determined in Section 722.7.1(a), on both the inside of the shaft and the outside of the shaft.

602.4.4 Type IV-HT. Type IV construction (Heavy Timber, HT) is that type of construction in which the exterior walls are of noncombustible materials and the interior building elements are of solid wood, laminated heavy timber or structural composite lumber (SCL), without concealed spaces. The minimum dimensions for permitted materials including solid timber, glued-laminated timber, structural composite lumber (SCL) and cross laminated timber (CLT) and details of Type IV construction shall comply with the provisions of this section and Section 2304.11. Exterior walls complying with Section 602.4.4.1 or 602.4.4.2 shall be permitted. Interior walls and partitions not less than one hour fire resistance rating or heavy timber conforming with Section 2304.11.2.2 shall be permitted.

Revise as follows:

~~602.4.1~~602.4.4.1 Fire-retardant-treated wood in exterior walls. *Fire-retardant-treated wood* framing and sheathing complying with Section 2303.2 shall be permitted within exterior wall assemblies not less than 6 inches (152 mm) in thickness with a 2-hour rating or less.

~~602.4.2~~602.4.4.2 Cross-laminated timber in exterior walls. *Cross-laminated timber* complying with Section 2303.1.4 shall be permitted within exterior wall assemblies not less than 6 inches (152 mm) in thickness with a 2-hour rating or less, provided the exterior surface of the cross-laminated timber is protected by one the following:

1. *Fire-retardant-treated wood* sheathing complying with Section 2303.2 and not less than ¹⁵/₃₂ inch (12 mm) thick;
2. *Gypsum board* not less than ¹/₂ inch (12.7 mm) thick; or
3. A noncombustible material.

~~602.4.3~~602.4.4.3 Exterior structural members. Where a horizontal separation of 20 feet (6096 mm) or more is provided, wood columns and arches conforming to heavy timber sizes complying with Section 2304.11 shall be permitted to be used externally.

**TABLE 601
FIRE-RESISTANCE RATING REQUIREMENTS FOR BUILDING ELEMENTS (HOURS)**

BUILDING ELEMENT	TYPE I		TYPE II		TYPE III		TYPE IV				TYPE V	
	A	B	A	B	A	B	A	B	C	HT	A	B
Primary structural frame ^f (see Section 202)	3 ^{a, b}	2 ^{a, b}	1 ^b	0	1 ^b	0	3 ^a	2 ^a	2 ^a	HT	1 ^b	0
Bearing walls Exterior ^{e, f} Interior	3 3 ^a	2 2 ^a	1 1	0 0	2 1	2 0	3 3	2 2	2 2	2 1/HT	1 1	0 0
Nonbearing walls and partitions Exterior	See Table 602											
Nonbearing walls and partitions Interior ^d	0	0	0	0	0	0	0	0	0	See Section 2304.11.2	0	0
Floor construction and associated secondary members (see Section 202)	2	2	1	0	1	0	2	2	2	HT	1	0
Roof construction and associated secondary members (see Section 202)	1 ^{1/2} ^b	1 ^{b, c}	1 ^{b, c}	0 ^c	1 ^{b, c}	0	1 1/2	1	1	HT	1 ^{b, c}	0

For SI: 1 foot = 304.8 mm.

- a. Roof supports: Fire-resistance ratings of primary structural frame and bearing walls are permitted to be reduced by 1 hour where supporting a roof only.
- b. Except in Group F-1, H, M and S-1 occupancies, fire protection of structural members in roof construction shall not be required, including protection of primary structural frame members, roof framing and decking where every part of the roof construction is 20 feet or more above any floor immediately below. Fire-retardant-treated wood members shall be allowed to be used for such unprotected members.
- c. In all occupancies, heavy timber complying with Section 2304.11 shall be allowed where a 1-hour or less fire-resistance rating is required.
- d. Not less than the fire-resistance rating required by other sections of this code.
- e. Not less than the fire-resistance rating based on fire separation distance (see Table 602).
- f. Not less than the fire-resistance rating as referenced in Section 704.10.

TABLE 602
FIRE-RESISTANCE RATING REQUIREMENTS FOR EXTERIOR WALLS BASED ON FIRE SEPARATION DISTANCE^a,
d, g

FIRE SEPARATION DISTANCE =X (feet)	TYPE OF CONSTRUCTION	OCCUPANCY GROUP H^e	OCCUPANCY GROUP F-1, M, S-1^f	OCCUPANCY GROUP A, B, E, F-2, I, Rⁱ, S-2, U^h
X < 5 ^b	All	3	2	1
5 ≤ X < 10	IA, <u>IVA</u>	3	2	11
	Others	2	1	
10 ≤ X < 30	IA, IB, <u>IVA, IVB</u>	2	1	1 ^c
	IIB, VB	1	0	0
	Others	1	1	1 ^c
X ≥ 30	All	0	0	0

For SI: 1 foot = 304.8 mm.

- a. Load-bearing exterior walls shall also comply with the fire-resistance rating requirements of Table 601.
- b. See Section 706.1.1 for party walls.
- c. Open parking garages complying with Section 406 shall not be required to have a fire-resistance rating.
- d. The fire-resistance rating of an exterior wall is determined based upon the fire separation distance of the exterior wall and the story in which the wall is located.
- e. For special requirements for Group H occupancies, see Section 415.6.
- f. For special requirements for Group S aircraft hangars, see Section 412.3.1.
- g. Where Table 705.8 permits nonbearing exterior walls with unlimited area of unprotected openings, the required fire-resistance rating for the exterior walls is 0 hours.
- h. For a building containing only a Group U occupancy private garage or carport, the exterior wall shall not be required to have a fire-resistance rating where the fire separation distance is 5 feet (1523 mm) or greater.
- i. For a Group R-3 building of Type II-B or Type V-B construction, the exterior wall shall not be required to have a fire-resistance rating where the fire separation distance is 5 feet (1523 mm) or greater.

Reason:

The Ad Hoc Committee on Tall Wood Buildings (TWB) was created by the ICC Board to explore the science of tall wood buildings and take action on developing code changes for tall wood buildings. The TWB has created several code change proposals with respect to the concept of tall buildings of mass timber and the background information is at the end of this Statement. Within the statement are important links to information, including documents and videos, used in the deliberations which resulted in these proposals.

The TWB and its various WGs held meetings, studied issues and sought input from various expert sources around the world. The TWB has posted those documents and input on its website for interested parties to follow its progress and to allow those parties to, in turn, provide input to the TWB.

At its first meeting, the TWB discussed a number of performance objectives to be met with the proposed criteria for tall wood buildings:

No collapse under reasonable scenarios of complete burn-out of fuel without automatic sprinkler protection being considered.

No unusually high radiation exposure from the subject building to adjoining properties to present a risk of ignition under reasonably severe fire scenarios.

No unusual response from typical radiation exposure from adjacent properties to present a risk of ignition of the subject building under reasonably severe fire scenarios.

No unusual fire department access issues.

Egress systems designed to protect building occupants during the design escape time, plus a factor of safety.

Highly reliable fire suppression systems to reduce the risk of failure during reasonably expected fire scenarios. The degree of reliability should be proportional to evacuation time (height) and the risk of collapse.

The comprehensive package of proposals from the TWB meet these performance objectives.

Definitions

Included in the proposal for Section 602.4 are three new/revised definitions; Wall, Load-Bearing; Mass Timber; and Noncombustible protection (for mass timber). They are important to understanding the subsequent proposed change to Section 602.4.

Load-bearing wall: The modification to the term “load-bearing wall” has been updated to include “mass timber” as a category equivalent to that of masonry or concrete. Based on the research done by the wood trade associations, mass timber walls (e.g. sawn, glued-laminated, cross-laminated timbers) have the ability to support the minimum 200 pounds per linear foot vertical load requirement.

Mass Timber: The term “mass timber” is being proposed to represent both the legacy heavy timber (a.k.a. Type IV construction) and the three (3) new construction types that are proposed for Chapter 6 of the IBC. The purpose of creating this term and definition was to establish a single term which represented the various sawn and engineered timber products that are referenced in IBC Chapter 23 (Wood) and in PRG-320 “Standard for Performance-rated Cross-laminated Timber.”

“Noncombustible Protection (For Mass Timber): The definition of “Noncombustible Protection (For Mass Timber)” is

created to address the passive fire protection of mass timber. Mass timber is permitted to have its own fire-resistance rating (e.g., Mass Timber only) or have a fire resistance rating based on the fire resistance through a combination of the mass timber fire-resistance plus protection by non-combustible materials as defined in Section 703.5 (e.g., additional materials that delay the combustion of mass timber, such as gypsum board). While it is not common to list a code section number within a definition it was felt necessary in this case to ensure that the user was able to understand the intent. The protection by a non-combustible material will act to delay the combustion of the Mass Timber.

Types of Construction

The Committee recognized that tall, mass timber buildings around the world generally fell into three categories: one in which the mass timber was fully protected by noncombustible protection, a second type in which the protection was permitted to be omitted to expose the wood in certain limited amounts of walls or ceilings, and a third type in which the mass timber for the structure was permitted to be unprotected.

The TWB also determined that fire testing was necessary to validate these concepts. At its first meeting, members discussed the nature and intention of fire testing so as to ensure meaningful results for the TWB and, more specifically, for the fire service. Subsequently a test plan was developed. The fire tests consisted of one-bedroom apartments on two levels, with both apartments having a corridor leading to a stairway. The purpose of the tests was to address the contribution of mass timber to a fire, the performance of connections, the performance of joints, and to evaluate conditions for responding fire personnel. The Fire WG then refined the test plan, which was implemented with a series of five, full-scale, multiple-story building tests at the Alcohol, Tobacco and Firearms (ATF) laboratories in Beltsville, MD. The results of those tests, as well as testing conducted by others, helped form the basis upon which the Codes WG developed its code change proposals. This code change proposal is one of those developed by the Codes WG and approved by the TWB.

To review a summary of the fire tests, please visit:

<http://bit.ly/ATF-firetestreport>

To watch summary videos of the fire tests, which are accelerated to run in 3-1/2 minutes each, please visit: <http://bit.ly/ATF-firetestvideos>.

Both of these links were confirmed active on 12/27/17.

The completely protected type of construction, as noted above, is identified as Type IV-A. The protection is defined by a new section, 722.7, proposed in a separate code change. Testing has shown that mass timber construction protected with noncombustible protection, primarily multiple layers of 5/8-inch Type X gypsum board, can survive a complete burnout of a residential fuel load without engaging the mass timber in the fire. (See video or report above.) In considering this type of construction and its potential height and/or allowable area, the TWB wanted to make sure that code users realize that the protection specified in the text applies to all building elements. Thus, the text clearly requires protection for the floor surface, all wall and ceiling surfaces, the inside roof surfaces, the underside of floor surfaces, and shafts. In addition, Type IV-A construction is proposed to have the same fire resistance rating requirements as the existing Type I-A construction, which sets forth requirements for 2-hour and 3-hour structural elements. The specified fire resistance rating for Type IV-A construction is conservative in that the fire resistance rating of the structural elements was selected to be able to passively sustain the fuel loads associated with the various occupancies without the benefit of automatic sprinkler protection, and without involving the contribution of the structural members, similar to the strategy employed in the IBC for Type I construction.

Type IV-B allows some exposed wood surfaces of the ceiling, the walls or columns and beams. The amount of exposed surface permitted to be installed, as well as the required separation between unprotected portions, is clearly specified to limit the contribution of the structure in an interior fire. For example, two different walls may share the unprotected area but the two walls must be separated by a distance of 15 feet. Type IV-B has been subjected to the same fire tests under the same conditions as Type IV-A and the results demonstrate that a predictable char layer develops on mass timber in the same fashion as traditional sawn lumber, provided that substantial delamination is avoided. (See video or report above.) It should be noted that, while portions of the mass timber may be unprotected, concealed spaces, shafts and other specified areas are required to be fully protected by noncombustible protection. Type IV-B is provided with the same base fire resistance requirements as the existing Type I-B construction, which sets forth requirements for 2-hour structural elements. Please note that the allowance per IBC Section 403.2.1.1 to reduce I-B construction to 1-hour structural elements is not proposed for Type IV-B construction. Essentially, where a building is permitted to be constructed of I-B construction and has 1-hour protection, that same building will still require 2-hour structural elements for Type IV-B construction.

Type IV-C construction permits fully exposed mass timber. Important caveats are that concealed spaces, shafts, elevator hoistways, and interior exit stairway enclosures are not permitted to be exposed, but instead are required to have noncombustible protection. The IV-C construction is differentiated from traditional Heavy Timber construction in that Type IV-C construction is required to be 2-hour fire rated. While the added fire rating is required, the committee

does not propose any additional height, in terms of feet, for Type IV-C buildings; in other words, the height in feet for Type IV-C and Type IV-HT are identical. However, due to the added fire resistance ratings, the committee has proposed added floors for some occupancy groups of Type IV-C construction.

Tables 601 and 602: Included in the proposal are modification of Tables 601 and 602. This is necessary to set the performance requirement for these new types of construction based upon mass timber. It should be noted that these Fire Resistance Ratings are set to have the requirements similar to those of Type I construction. In other words, IV-A has the same FRR as I-A; IV-B has the same FRR as I-B. Because there is no Type I corollary to IV-C, it was set the same as IV-B. The IV-C has to achieve all its fire resistance by the performance of the mass timber itself because no noncombustible protection is required. This is reflected in greatly reduced permitted height, in both feet and stories, in other TWB proposals to Table 504.3, 504.4 and 506.2.

Background information: The ICC Board approved the establishment of an ad hoc committee for tall wood buildings in December of 2015. The purpose of the ad hoc committee is to explore the science of tall wood buildings and to investigate the feasibility and take action on developing code changes for tall wood buildings. The committee is comprised of a balance of stakeholders with additional opportunities for interested parties to participate in the four Work Groups established by the ad hoc committee, namely: Code; Fire; Standards/Definitions; and Structural. For more information, be sure to visit the ICC website <https://www.iccsafe.org/codes-tech-support/cs/icc-ad-hoc-committee-on-tall-wood-buildings/> (link active and up to date as of 12/27/17). As seen in the “Meeting Minutes and Documents” and “Resource Documents” sections of the committee web page, the ad hoc committee reviewed a substantial amount of information in order to provide technical justification for code proposals.

The ad hoc committee developed proposals for the followings code sections. The committee believes this package of code changes will result in regulations that adequately address the fire and life safety issues of tall mass timber buildings.

IBC Code Section	Description
403.3.2	Water supply requirements for fire pumps in high rise buildings of Type IVA and IVB construction.
504.3	Allowable building height (feet) for buildings of Type IVA, IVB and IVC construction. No changes to Type IV HT construction.
504.4	Allowable building height (stories) for buildings of Type IVA, IVB and IVC construction. No changes to Type IV HT.
506.2	Allowable building area for buildings of Type IVA, IVB and IVC construction. No changes to Type IV HT.
508.4.4.1 509.4.1.1 (new)	Requirements for mass timber building elements serving as fire barriers or horizontal assemblies in buildings of Type IVB or IVC construction.
602.4	Type of Construction requirements for new proposed types of construction: Types IVA, IVB and IVC. No changes to Type IV HT construction. Includes definitions for new terms: Mass timber and Noncombustible protection (mass timber). THIS IS THE KEY CODE CHANGE PROPOSAL WHICH OUTLINES THE CONSTRUCTION REQUIREMENTS FOR THE PROPOSED NEW TYPE OF MASS TIMBER BUILDINGS. THE PROPOSAL ALSO ADDRESSES CONCEALED SPACES, ADHESIVE PERFORMANCE AND EXTERIOR WALL PROTECTION.
703.8 (new)	The performance method to determine the increase to the fire resistance rating provided by noncombustible protection applied to the mass timber building element.
703.9 (new)	Requirements for sealants and adhesives to be placed at abutting edges and intersections of mass timber building elements. The reason statement references a Group B proposal to Chapter 17 for special inspection requirements of sealants and adhesives.
718.2.1	Requirements on the use of mass timber building elements used for Fireblocking.
722.7 (new)	Requirements for the fire resistance rating of mass timber elements, including minimum required protection and gypsum board attachment requirements.
3102	Requirements for membrane structures using Type IV HT construction.
3314.7 (new)	New special precautions during construction of buildings of Types IVA, IVB and IVC construction: Standpipes; Water supply for fire department connections; Noncombustible protection required for mass timber elements as construction height increases.
Appendix	Requirements for walls, floors and roofs of Type IV HT construction in buildings located in Fire Districts.
IFC Code Section	Description
701.6	Requirements which stipulate the owner's responsibility to maintain inventory of all required fire resistance rated construction in buildings of Types IVA and IVB construction. This includes an annual inspection and proper repair where necessary.
Proposed changes to be submitted in 2019 Group B	
IBC Chapter 17	Required special inspections of mass timber construction <ul style="list-style-type: none"> • Structural • Sealants and adhesives (see IBC 703.8)
IBC Chapter 23	An update to referenced standard APA PRG 320 Standard for Performance –rated Cross-laminated Timber which is currently undergoing revision to ensure the adequacy of the adhesives under fire conditions.

In addition, fire tests designed to simulate the three new construction types (Types IVA, IVB and IVC) in the ad hoc committee proposals were conducted at the Alcohol Tobacco and Firearms test lab facility. The TWB was involved in the design of the tests, and many members witnessed the test in person or online. The results of the series of 5 fire tests provide additional support for these proposals, and validate the fire performance for each of the types of construction proposed by the committee. The fire tests consisted of one-bedroom apartments on two levels, with both apartments having a corridor leading to a stair. The purpose of the tests was to address the contribution of mass timber to a fire, the performance of connections, the performance of through-penetration fire stops, and to evaluate conditions for responding fire personnel.

To review a summary of the fire tests, please visit:

<http://bit.ly/ATF-firetestreport>

To watch summary videos of the fire tests, which are accelerated to run in 3 ½ minutes, please visit:

<http://bit.ly/ATF-firetestvideos>

Both of these links were confirmed active on 12/27/17.

Cost Impact

The code change proposal will not increase or decrease the cost of construction .

This section provides information that was not previously set forth in the code, and does not change the requirements of current code, thus there is no cost impact when compared with present requirements.

Analysis: The standards referenced in the changes in this proposal, DOC PS1, ASTM E1354, ASTM E84 and UL 723, are already referenced in the International Codes.

Internal ID: 852

G109-18

IBC: 602.4, 602.4.3 (New), 2304.11.3, 2304.11.4

Proponent: Dennis Richardson, American Wood Council, representing American Wood Council (drichardson@awc.org)

2018 International Building Code

Revise as follows:

602.4 Type IV. Type IV construction is that type of construction in which the exterior walls are of noncombustible materials and the interior building elements are of solid wood, laminated wood, heavy timber (HT) or structural composite lumber (SCL) without concealed spaces, spaces or with concealed spaces complying with Section 602.4.3. The minimum dimensions for permitted materials including solid timber, glued-laminated timber, structural composite lumber (SCL), and cross-laminated timber and details of Type IV construction shall comply with the provisions of this section and Section 2304.11. Exterior walls complying with Section 602.4.1 or 602.4.2 shall be permitted. Interior walls and partitions not less than 1-hour fire-resistance rating-rated or heavy timber complying with Section 2304.11.2.2 shall be permitted.

602.4.1 Fire-retardant-treated wood in exterior walls. *Fire-retardant-treated wood* framing and sheathing complying with Section 2303.2 shall be permitted within exterior wall assemblies not less than 6 inches (152 mm) in thickness with a 2-hour rating or less.

602.4.2 Cross-laminated timber in exterior walls. *Cross-laminated timber* complying with Section 2303.1.4 shall be permitted within exterior wall assemblies not less than 6 inches (152 mm) in thickness with a 2-hour rating or less, provided the exterior surface of the cross-laminated timber is protected by one the following:

1. *Fire-retardant-treated wood* sheathing complying with Section 2303.2 and not less than $15/32$ inch (12 mm) thick;
2. *Gypsum board* not less than $1/2$ inch (12.7 mm) thick; or
3. A noncombustible material.

Add new text as follows:

602.4.3 Concealed spaces. Concealed spaces shall not contain combustible materials other than building elements and electrical, mechanical, fire protection, or plumbing materials and equipment. Concealed spaces shall comply with applicable provisions of Section 718. Concealed spaces shall be protected in accordance with one or more of the following:

1. The building shall be sprinklered throughout in accordance with Section 903.3.1.1 and automatic sprinklers shall also be provided in the concealed space.
2. The concealed space shall be completely filled with noncombustible insulation.
3. Surfaces within the concealed space shall be fully sheathed with not less than 5/8 inch Type X gypsum board.

Exception: Concealed spaces within interior walls and partitions with a one hour or greater fire resistance rating complying Section 2304.11.2.2 shall not require additional protection.

Revise as follows:

2304.11.3 Floors. Floors shall be without concealed spaces, spaces or with concealed spaces complying with Section 602.4.3. Wood floors shall be constructed in accordance with Section 2304.11.3.1 or 2304.11.3.2.

2304.11.4 Roof decks. Roofs shall be without concealed spaces and roof or with concealed spaces complying with Section 602.4.3. Roof decks shall be constructed in accordance with Section 2304.11.4.1 or 2304.11.4.2. Other types of decking shall be an alternative that provides equivalent fire resistance and structural properties. Where supported by a wall, roof decks shall be anchored to walls to resist forces determined in accordance with Chapter 16. Such anchors shall consist of steel bolts, lags, screws or *approved* hardware of sufficient strength to resist prescribed forces.

Reason:

The option of having protected concealed spaces in Type IV buildings is important to encourage the adaptive re-use of existing heavy timber buildings as well as to provide for the installation of mechanicals in Type IV cross laminated timber (CLT) construction. In addition to the current requirements for all concealed spaces in combustible construction, this change would require additional protection of the concealed spaces with sprinkler coverage, or eliminating all air space with noncombustible insulation, or covering all combustible surfaces with gypsum. These alternatives are the same protection required for concealed spaces in NFPA 13, except they are slightly more restrictive since 5/8-inch Type X gypsum is required in the one case. In addition, because the provisions are taken from NFPA 13, in order to use these provisions, the entire building must be protected by a sprinkler system complying with NFPA 13.

A similar change was recently successful in NFPA 220 and NFPA 5000. This proposal is more conservative in that it requires 5/8-inch Type X gypsum instead of 1/2 -inch gypsum in the alternative for sheathing combustible concealed spaces with gypsum in proposed section 602.4.3.

The change from “rating” to “rated” in Section 602.4 is editorial for good grammar.

Cost Impact

The code change proposal will not increase or decrease the cost of construction .

Will not increase the cost of construction. The code change provides the option of having protected concealed spaces in Type IV HT buildings, therefore does not increase the cost of construction.

Internal ID: 1706

G110-18

IBC: 602.4.1, 602.4.2

Proponent: James Smith, American Wood Council, representing American Wood Council (jsmith@awc.org); Sam Francis, representing American Wood Council (sfrancis@awc.org)

2018 International Building Code

Revise as follows:

602.4.1 Fire-retardant-treated wood in exterior walls. *Fire-retardant-treated wood* framing and sheathing complying with Section 2303.2 shall be permitted within exterior wall assemblies ~~not less than 6 inches (152 mm) in thickness~~ with a 2-hour rating or less.

602.4.2 Cross-laminated timber in exterior walls. *Cross-laminated timber* ~~not less than 4 inches (102 mm) in thickness~~ complying with Section 2303.1.4 shall be permitted within exterior wall assemblies ~~not less than 6 inches (152 mm) in thickness~~ with a 2-hour rating or less, provided the exterior surface of the cross-laminated timber is protected by one the following:

1. *Fire-retardant-treated wood* sheathing complying with Section 2303.2 and not less than $1\frac{5}{32}$ inch (12 mm) thick;
2. *Gypsum board* not less than $\frac{1}{2}$ inch (12.7 mm) thick; or
3. A noncombustible material.

Reason:

This code change corrects a correlation issue that was the result of two conflicting code changes that were both approved in the last cycle.

Code change 184-15, Approved as Submitted, eliminated the minimum thickness dimension of the exterior wall assembly for both Cross Laminated Timber (CLT) and Fire Retardant Treated Wood (FRTW) exterior walls, and introduced a minimum thickness for the CLT itself. G179-15, also Approved as Submitted, re-introduced the minimum wall assembly thickness into these sections in order to provide a re-organization of provisions without making any technical changes to the existing requirements. Correlation was made in favor of G179-15, having the effect of nullifying the action of G184-15, which was not anticipated.

The previous action on G184-15 should be affirmed by approval of this proposal for the same reasons it was originally approved: a minimum thickness for the CLT is a better parameter for structural integrity than an overall thickness of wall, since overall thickness could include exterior sheathing, cladding, and exterior insulation. This proposal will provide the thickness required for the CLT. In regard to FRTW exterior walls, the thickness of the assembly is not a significant factor, rather the required fire resistance rating is. A minimum thickness for the entire exterior wall assembly is unnecessary.

Cost Impact

The code change proposal will not increase or decrease the cost of construction .

This is a correlation issue regarding two separate proposals Approved as Submitted. There are no technical changes that were not already approved in 2015.

Internal ID: 722

G111-18

IBC: 602.4.2

Proponent: Dennis Richardson, American Wood Council, representing American Wood Council (drichardson@awc.org)

2018 International Building Code

Revise as follows:

602.4.2 Cross-laminated timber in exterior walls. *Cross-laminated timber* complying with Section 2303.1.4 shall be permitted within exterior wall assemblies not less than 6 inches (152 mm) in thickness with a 2-hour rating or ~~less; provided the less.~~ ~~Heavy timber structural members appurtenant to the CLT exterior wall shall meet the requirements of Table 2304.11 and be fire-resistance rated as required for the exterior wall.~~ The exterior surface of the cross-laminated ~~timber is timber~~ and heavy timber elements shall be protected by one the following:

1. *Fire-retardant-treated wood* sheathing complying with Section 2303.2 and not less than $1\frac{5}{32}$ inch (12 mm) thick;
2. *Gypsum board* not less than $\frac{1}{2}$ inch (12.7 mm) thick; or
3. A noncombustible material.

Reason:

The code currently does not recognize that heavy timber members could be used as a beam, header, column or other boundary element within a wall of CLT. Glued laminated, SCL, or solid sawn heavy timber elements having the same rating, thickness, and protection as required for the CLT will have no significant difference in fire performance. This is a common sense approach to the current code, but should be made explicit.

Cost Impact

The code change proposal will not increase or decrease the cost of construction .

This code change clarifies that additional heavy timber elements may be required as part of a CLT wall and they are permitted as part of the solid timber built up assembly. This clarifies the application of existing language and neither increases or decreases the cost of construction. It merely clarifies options that are currently used under common sense interpretation by the code official.

Internal ID: 1786

G112-18

IBC: 603.1

Proponent: John Williams, Chair, representing Healthcare Committee (AHC@iccsafe.org)

2018 International Building Code

Revise as follows:

603.1 Allowable materials. Combustible materials shall be permitted in buildings of Type I or II construction in the following applications and in accordance with Sections 603.1.1 through 603.1.3:

1. *Fire-retardant-treated wood* shall be permitted in:
 - 1.1. Nonbearing partitions where the required *fire-resistance rating* is 2 hours or ~~less~~ less except in shaft enclosures within Group I-2 and ambulatory care facilities.
 - 1.2. Nonbearing *exterior walls* where fire-resistance-rated construction is not required.
 - 1.3. Roof construction, including girders, trusses, framing and decking.

Exception: In buildings of Type IA construction exceeding two *stories above grade plane*, *fire-retardant-treated wood* is not permitted in roof construction where the vertical distance from the upper floor to the roof is less than 20 feet (6096 mm).
 - 1.4. Balconies, porches, decks and exterior stairways not used as required exits on buildings three *stories* or less above grade plane.
2. Thermal and acoustical insulation, other than foam plastics, having a *flame spread index* of not more than 25.

Exceptions:

 1. Insulation placed between two layers of noncombustible materials without an intervening airspace shall be allowed to have a *flame spread index* of not more than 100.
 2. Insulation installed between a finished floor and solid decking without intervening airspace shall be allowed to have a *flame spread index* of not more than 200.
3. Foam plastics in accordance with Chapter 26.
4. Roof coverings that have an A, B or C classification.
5. *Interior floor finish* and floor covering materials installed in accordance with Section 804.
6. Millwork such as doors, door frames, window sashes and frames.
7. *Interior wall and ceiling finishes* installed in accordance with Section 803.
8. *Trim* installed in accordance with Section 806.
9. Where not installed greater than 15 feet (4572 mm) above grade, show windows, nailing or furring strips and wooden bulkheads below show windows, including their frames, aprons and show cases.
10. Finish flooring installed in accordance with Section 805.
11. Partitions dividing portions of stores, offices or similar places occupied by one tenant only and that do not establish a *corridor* serving an *occupant load* of 30 or more shall be permitted to be constructed of *fire-retardant-treated wood*, 1-hour fire-resistance-rated construction or of wood panels or similar light construction up to 6 feet (1829 mm) in height.
12. Stages and platforms constructed in accordance with Sections 410.2 and 410.3, respectively.
13. Combustible *exterior wall coverings*, balconies and similar projections and bay or oriel windows in accordance with Chapter 14 and Section 705.2.3.1.
14. Blocking such as for handrails, millwork, cabinets and window and door frames.
15. Light-transmitting plastics as permitted by Chapter 26.
16. Mastics and caulking materials applied to provide flexible seals between components of *exterior wall* construction.
17. Exterior plastic veneer installed in accordance with Section 2605.2.
18. Nailing or furring strips as permitted by Section 803.15.

19. Heavy timber as permitted by Note c to Table 601 and Sections 602.4.3 and 705.2.3.1.
20. Aggregates, component materials and admixtures as permitted by Section 703.2.2.
21. Sprayed fire-resistant materials and intumescent and mastic fire-resistant coatings, determined on the basis of *fire resistance* tests in accordance with Section 703.2 and installed in accordance with Sections 1705.14 and 1705.15, respectively.
22. Materials used to protect penetrations in fire-resistance-rated assemblies in accordance with Section 714.
23. Materials used to protect joints in fire-resistance-rated assemblies in accordance with Section 715.
24. Materials allowed in the concealed spaces of buildings of Types I and II construction in accordance with Section 718.5.
25. Materials exposed within plenums complying with Section 602 of the International Mechanical Code.
26. Wall construction of freezers and coolers of less than 1,000 square feet (92.9 m²), in size, lined on both sides with noncombustible materials and the building is protected throughout with an *automatic sprinkler system* in accordance with Section 903.3.1.1.

Reason:

This new language is required in order to conform with Federal Standards and CMS enforcement rules (K163). Fire-retardant (FRT) wood has previously not been considered equivalent to a non-combustible material, however codes have recently changed to permit FRT in certain locations. Centers for Medicaid and Medicare Services does not accept this material in shaft construction.

This proposal is submitted by the ICC Committee on Healthcare (CHC). The CHC was established by the ICC Board to evaluate and assess contemporary code issues relating to healthcare facilities. This is a joint effort between ICC and the American Society for Healthcare Engineering (ASHE), a subsidiary of the American Hospital Association, to eliminate duplication and conflicts in healthcare regulation. In 2017 the CHC held 2 open meetings and numerous conference calls, which included members of the committees as well as any interested parties, to discuss and debate the proposed changes. Information on the CHC, including: meeting agendas; minutes; reports; resource documents; presentations; and all other materials developed in conjunction with the CHC effort can be downloaded from the CHC website at: <https://www.iccsafe.org/codes-tech-support/cs/icc-committee-on-healthcare/>.

Cost Impact

The code change proposal will increase the cost of construction .

This proposal will increase cost based on the replacement of fire retardant treated (FRT) wood with metal studs or other construction. However, it does not add cost to the healthcare industry because certified facilities already follow these requirements in the context of the CMS federal standards.

Internal ID: 579

G113-18

IBC: 603.1

Proponent: John Williams, Chair, representing Healthcare Committee (AHC@iccsafe.org)

2018 International Building Code

Revise as follows:

603.1 Allowable materials. Combustible materials shall be permitted in buildings of Type I or II construction in the following applications and in accordance with Sections 603.1.1 through 603.1.3:

1. *Fire-retardant-treated wood* shall be permitted in:
 - 1.1. Nonbearing partitions where the required *fire-resistance rating* is 2 hours or less.
 - 1.2. Nonbearing *exterior walls* where fire-resistance-rated construction is not required.
 - 1.3. Roof construction, including girders, trusses, framing and decking.

Exception-Exceptions:

 1. In buildings of Type IA construction exceeding two *stories above grade plane*, *fire-retardant-treated wood* is not permitted in roof construction where the vertical distance from the upper floor to the roof is less than 20 feet (6096 mm).
 2. Group I-2, combustible roof construction shall be covered by minimum of a Class A roof covering or roof assembly, and shall be separated from the story below by a horizontal assembly with a fire-resistance rating of not less than 2 hours.
 - 1.4. Balconies, porches, decks and exterior stairways not used as required exits on buildings three *stories* or less above grade plane.
2. Thermal and acoustical insulation, other than foam plastics, having a *flame spread index* of not more than 25.

Exceptions:

 1. Insulation placed between two layers of noncombustible materials without an intervening airspace shall be allowed to have a *flame spread index* of not more than 100.
 2. Insulation installed between a finished floor and solid decking without intervening airspace shall be allowed to have a *flame spread index* of not more than 200.
3. Foam plastics in accordance with Chapter 26.
4. Roof coverings that have an A, B or C classification.
5. *Interior floor finish* and floor covering materials installed in accordance with Section 804.
6. Millwork such as doors, door frames, window sashes and frames.
7. *Interior wall and ceiling finishes* installed in accordance with Section 803.
8. *Trim* installed in accordance with Section 806.
9. Where not installed greater than 15 feet (4572 mm) above grade, show windows, nailing or furring strips and wooden bulkheads below show windows, including their frames, aprons and show cases.
10. Finish flooring installed in accordance with Section 805.
11. Partitions dividing portions of stores, offices or similar places occupied by one tenant only and that do not establish a *corridor* serving an *occupant load* of 30 or more shall be permitted to be constructed of *fire-retardant-treated wood*, 1-hour fire-resistance-rated construction or of wood panels or similar light construction up to 6 feet (1829 mm) in height.
12. Stages and platforms constructed in accordance with Sections 410.2 and 410.3, respectively.
13. Combustible *exterior wall coverings*, balconies and similar projections and bay or oriel windows in accordance with Chapter 14 and Section 705.2.3.1.
14. Blocking such as for handrails, millwork, cabinets and window and door frames.
15. Light-transmitting plastics as permitted by Chapter 26.

16. Mastics and caulking materials applied to provide flexible seals between components of *exterior wall* construction.
17. Exterior plastic veneer installed in accordance with Section 2605.2.
18. Nailing or furring strips as permitted by Section 803.15.
19. Heavy timber as permitted by Note c to Table 601 and Sections 602.4.3 and 705.2.3.1.
20. Aggregates, component materials and admixtures as permitted by Section 703.2.2.
21. Sprayed fire-resistant materials and intumescent and mastic fire-resistant coatings, determined on the basis of *fire resistance* tests in accordance with Section 703.2 and installed in accordance with Sections 1705.14 and 1705.15, respectively.
22. Materials used to protect penetrations in fire-resistance-rated assemblies in accordance with Section 714.
23. Materials used to protect joints in fire-resistance-rated assemblies in accordance with Section 715.
24. Materials allowed in the concealed spaces of buildings of Types I and II construction in accordance with Section 718.5.
25. Materials exposed within plenums complying with Section 602 of the International Mechanical Code.
26. Wall construction of freezers and coolers of less than 1,000 square feet (92.9 m²), in size, lined on both sides with noncombustible materials and the building is protected throughout with an *automatic sprinkler system* in accordance with Section 903.3.1.1.

Reason:

This proposal creates conformance with more restrictive federal certification requirements (K162). The goal here is to create a complete two hour assembly below the lowest combustible member. This creates added layers of protection for protect in place environment from fires originating in mechanical equipment, embers from adjacent fires, etc.

This proposal is submitted by the ICC Committee on Healthcare (CHC). The CHC was established by the ICC Board to evaluate and assess contemporary code issues relating to healthcare facilities. This is a joint effort between ICC and the American Society for Healthcare Engineering (ASHE), a subsidiary of the American Hospital Association, to eliminate duplication and conflicts in healthcare regulation. In 2017 the CHC held 2 open meetings and numerous conference calls, which included members of the committees as well as any interested parties, to discuss and debate the proposed changes. Information on the CHC, including: meeting agendas; minutes; reports; resource documents; presentations; and all other materials developed in conjunction with the CHC effort can be downloaded from the CHC website at: <https://www.iccsafe.org/codes-tech-support/cs/icc-committee-on-healthcare/>.

Cost Impact

The code change proposal will increase the cost of construction .

This proposal will increase cost based on the added 2-hour horizontal separation and potentially higher roof cover rating. However, it does not add cost to the healthcare industry because certified facilities already follow these requirements in the context of the CMS federal standards.

Internal ID: 575

G114-18

IBC: 603.1

Proponent: Carl Martin, representing self (carl.martin@ncdoi.gov)

2018 International Building Code

Revise as follows:

603.1 Allowable materials. Combustible materials shall be permitted in buildings of Type I or II construction in the following applications and in accordance with Sections 603.1.1 through 603.1.3:

1. *Fire-retardant-treated wood* shall be permitted in:
 - 1.1. Nonbearing partitions where the required *fire-resistance rating* is 2 hours or less.
 - 1.2. Nonbearing *exterior walls* where fire-resistance-rated construction is not required.
 - 1.3. Roof construction, including girders, trusses, framing and decking.

Exception: In buildings of Type IA construction exceeding two *stories above grade plane*, *fire-retardant-treated wood* is not permitted in roof construction where the vertical distance from the upper floor to the roof is less than 20 feet (6096 mm).
 - 1.4. Balconies, porches, decks and exterior stairways not used as required exits on buildings three *stories* or less above grade plane.
2. Thermal and acoustical insulation, other than foam plastics, having a *flame spread index* of not more than 25.

Exceptions:

 1. Insulation placed between two layers of noncombustible materials without an intervening airspace shall be allowed to have a *flame spread index* of not more than 100.
 2. Insulation installed between a finished floor and solid decking without intervening airspace shall be allowed to have a *flame spread index* of not more than 200.
3. Foam plastics in accordance with Chapter 26.
4. Roof coverings that have an A, B or C classification.
5. *Interior floor finish* and floor covering materials installed in accordance with Section 804.
6. Millwork such as doors, door frames, window sashes and frames.
7. *Interior wall and ceiling finishes* installed in accordance with Section 803.
8. *Trim* installed in accordance with Section 806.
9. Where not installed greater than 15 feet (4572 mm) above grade, show windows, nailing or furring strips and wooden bulkheads below show windows, including their frames, aprons and show cases.
10. Finish flooring installed in accordance with Section 805.
11. Partitions dividing portions of stores, offices or similar places occupied by one tenant only and that do not establish a *corridor* serving an *occupant load* of 30 or more shall be permitted to be constructed of *fire-retardant-treated wood*, 1-hour fire-resistance-rated construction or of wood panels or similar light construction up to 6 feet (1829 mm) in height.
12. Stages and platforms constructed in accordance with Sections 410.2 and 410.3, respectively.
13. Combustible *exterior wall coverings*, balconies and similar projections and bay or oriel windows in accordance with Chapter 14 and Section 705.2.3.1.
14. Blocking such as for handrails, millwork, cabinets and window and door frames.
15. Light-transmitting plastics as permitted by Chapter 26.
16. Mastics and caulking materials applied to provide flexible seals between components of *exterior wall* construction.
17. Exterior plastic veneer installed in accordance with Section 2605.2.
18. Nailing or furring strips as permitted by Section 803.15.

19. Heavy timber as permitted by Note c to Table 601 and Sections 602.4.3 and 705.2.3.1.
20. Aggregates, component materials and admixtures as permitted by Section 703.2.2.
21. Sprayed fire-resistant materials and intumescent and mastic fire-resistant coatings, determined on the basis of *fire resistance* tests in accordance with Section 703.2 and installed in accordance with Sections 1705.14 and 1705.15, respectively.
22. Materials used to protect penetrations in fire-resistance-rated assemblies in accordance with Section 714.
23. Materials used to protect joints in fire-resistance-rated assemblies in accordance with Section 715.
24. Materials allowed in the concealed spaces of buildings of Types I and II construction in accordance with Section 718.5.
25. Materials exposed within plenums complying with Section 602 of the International Mechanical Code.
26. Wall construction of freezers and coolers of less than 1,000 square feet (92.9 m²), in size, lined on both sides with noncombustible materials and the building is protected throughout with an *automatic sprinkler system* in accordance with Section 903.3.1.1. 27.
27. Wood nailers for parapet flashing and roof cants.

Reason:

Wood nailers used for roof parapets and cants are necessary for properly fastening roof materials and does not provide a significant amount of combustible material to the construction type.

Cost Impact

The code change proposal will not increase or decrease the cost of construction .

This change addresses common construction practice.

Internal ID: 570

G115-18

IBC: 603.1

Proponent: Misty Guard, Bradley Corporation, representing Bradley Corporation

2018 International Building Code

Revise as follows:

603.1 Allowable materials. Combustible materials shall be permitted in buildings of Type I or II construction in the following applications and in accordance with Sections 603.1.1 through 603.1.3:

1. *Fire-retardant-treated wood* shall be permitted in:
 - 1.1. Nonbearing partitions where the required *fire-resistance rating* is 2 hours or less.
 - 1.2. Nonbearing *exterior walls* where fire-resistance-rated construction is not required.
 - 1.3. Roof construction, including girders, trusses, framing and decking.

Exception: In buildings of Type IA construction exceeding two *stories above grade plane*, *fire-retardant-treated wood* is not permitted in roof construction where the vertical distance from the upper floor to the roof is less than 20 feet (6096 mm).
 - 1.4. Balconies, porches, decks and exterior stairways not used as required exits on buildings three *stories* or less above grade plane.
2. Thermal and acoustical insulation, other than foam plastics, having a *flame spread index* of not more than 25.

Exceptions:

 1. Insulation placed between two layers of noncombustible materials without an intervening airspace shall be allowed to have a *flame spread index* of not more than 100.
 2. Insulation installed between a finished floor and solid decking without intervening airspace shall be allowed to have a *flame spread index* of not more than 200.
3. Foam plastics in accordance with Chapter 26.
4. Roof coverings that have an A, B or C classification.
5. *Interior floor finish* and floor covering materials installed in accordance with Section 804.
6. Millwork such as doors, door frames, window sashes and frames.
7. *Interior wall and ceiling finishes* installed in accordance with Section 803.
8. *Trim* installed in accordance with Section 806.
9. Where not installed greater than 15 feet (4572 mm) above grade, show windows, nailing or furring strips and wooden bulkheads below show windows, including their frames, aprons and show cases.
10. Finish flooring installed in accordance with Section 805.
11. Partitions dividing portions of stores, offices or similar places occupied by one tenant only and that do not establish a *corridor* serving an *occupant load* of 30 or more shall be permitted to be constructed of *fire-retardant-treated wood*, 1-hour fire-resistance-rated construction or of wood panels or similar light construction up to 6 feet (1829 mm) in height.
12. Stages and platforms constructed in accordance with Sections 410.2 and 410.3, respectively.
13. Combustible *exterior wall coverings*, balconies and similar projections and bay or oriel windows in accordance with Chapter 14 and Section 705.2.3.1.
14. Blocking such as for handrails, millwork, cabinets and window and door frames.
15. Light-transmitting plastics as permitted by Chapter 26.
16. Mastics and caulking materials applied to provide flexible seals between components of *exterior wall* construction.
17. Exterior plastic veneer installed in accordance with Section 2605.2.
18. Nailing or furring strips as permitted by Section 803.15.

19. Heavy timber as permitted by Note c to Table 601 and Sections 602.4.3 and 705.2.3.1.
20. Aggregates, component materials and admixtures as permitted by Section 703.2.2.
21. Sprayed fire-resistant materials and intumescent and mastic fire-resistant coatings, determined on the basis of *fire resistance* tests in accordance with Section 703.2 and installed in accordance with Sections 1705.14 and 1705.15, respectively.
22. Materials used to protect penetrations in fire-resistance-rated assemblies in accordance with Section 714.
23. Materials used to protect joints in fire-resistance-rated assemblies in accordance with Section 715.
24. Materials allowed in the concealed spaces of buildings of Types I and II construction in accordance with Section 718.5.
25. Materials exposed within plenums complying with Section 602 of the International Mechanical Code.
26. Wall construction of freezers and coolers of less than 1,000 square feet (92.9 m²), in size, lined on both sides with noncombustible materials and the building is protected throughout with an *automatic sprinkler system* in accordance with Section 903.3.1.1.
27. Toilet and urinal partitions installed in accordance with Section 1209.
28. Combustible lockers complying with Section 808.4 of the International Fire Code.

Reason:

Section 603.1 attempts to list all of the combustible materials installed in noncombustible buildings. However, there are two items not currently listed that are permitted by the code, partitions for plumbing fixtures and lockers. Both items are available in both combustible and noncombustible materials. Combustible partitions and lockers are currently permitted in the Building Code and Fire Code.

The proposed text will add reference to the appropriate sections of code. Toilet and urinal partitions are regulated by Section 1209. Lockers are listed in Section 808.4 of the International Fire Code.

This change will clarify the acceptance of combustible toilet and urinal partitions and lockers in noncombustible buildings.

Bibliography:

Ahrens, M. (2017). Non-Residential Structure Fires that Originated in Lavatories, Locker Rooms or Coat Check Rooms. Quincy, MA: NFPA Research.

<https://www.dropbox.com/sh/0e177098908o5up/AADoei27Mnp3XfjaA9rreawQa?dl=0> Established 1.24.18

Cost Impact

The code change proposal will not increase or decrease the cost of construction .

There is no cost associated with this change since the code change will merely provide other options for complying with the current requirements. There are no new mandatory requirements being added.

Internal ID: 1850

G116-18 Part I

IBC: 1202.1, 1202.1.1 (New), 1202.1.2 (New)

Proponent: Keith Flanders, Cosentini Associates, representing self (kflanders@cosentini.com)

THIS IS A 2 PART CODE CHANGE PROPOSAL. PART I WILL BE HEARD BY THE GENERAL CODE DEVELOPMENT COMMITTEE. PART II WILL BE HEARD BY THE MECHANICAL CODE COMMITTEE. SEE THE TENTATIVE HEARING ORDERS FOR THESE COMMITTEES.

2018 International Building Code

Revise as follows:

1202.1 General. Buildings shall be provided with natural ventilation in accordance with Section 1202.5, or mechanical ventilation in accordance with the International Mechanical Code. ~~Where the air infiltration rate in a dwelling unit is less than 5 air changes per hour where tested with a blower door at a pressure 0.2 inch w.c. (50 Pa) in accordance with Section R402.4.1.2 of the International Energy Conservation Code Residential Provisions, the dwelling unit~~ Dwelling units shall be ventilated by mechanical means in accordance with Section 403 of the International Mechanical Code. in accordance with Section 1202.1.1 or Section 1202.1.2. *Ambulatory care facilities* and Group I-2 occupancies shall be ventilated by mechanical means in accordance with Section 407 of the International Mechanical Code.

Add new text as follows:

1202.1.1 Natural Ventilation. Dwelling units provided with natural ventilation in accordance with Section 1202.5 shall have an air infiltration rate of not less than 5 air changes per hour. The air infiltration rate shall be tested with a blower door at a pressure of 0.2 inch w.c. (50 Pa) in accordance with Section R402.4.1.2 of the International Energy Conservation Code.

1202.1.2 Mechanical Ventilation. Dwelling units provided with mechanical ventilation shall be in accordance with Section 403 of the International Mechanical Code.

Internal ID: 1042

G116-18 Part II

IMC: 401.2, 401.2.1 (New), 401.2.2 (New)

Proponent: Keith Flanders, Cosentini Associates, representing self (kflanders@cosentini.com)

2018 International Mechanical Code

Revise as follows:

401.2 Ventilation required. Every occupied space shall be ventilated by natural means in accordance with Section 402 or by mechanical means in accordance with Section 403. ~~Where the air infiltration rate in a dwelling unit is less than 5 air changes per hour when tested with a blower door at a pressure of 0.2 inch water column (50 Pa) in accordance with Section R402.4.1.2 of the International Energy Conservation Code, the dwelling unit shall be ventilated by mechanical means in accordance with Section 403.~~ Dwelling units shall be ventilated in accordance with the ventilation method specified in Section 401.2.1 or 401.2.2. Ambulatory care facilities and Group I-2 occupancies shall be ventilated by mechanical means in accordance with Section 407.

Add new text as follows:

401.2.1 Natural Ventilation. Dwelling units shall be provided with natural ventilation in accordance with Section 402 and shall have an air infiltration rate of not less than 5 air changes per hour. The air infiltration rate shall be tested with a blower door at a pressure of 0.2 inch w.c. (50 Pa) in accordance with Section R402.4.1.2 of the International Energy Conservation Code.

401.2.2 Mechanical Ventilation. Dwelling units shall be provided with mechanical ventilation in accordance with Section 403.

Reason:

The provisions for ventilation from dwelling units has been modified in recent editions of the code creating unnecessary confusion among the building industry. Accordingly, this proposal seeks to clarify the requirements.

It is understood the intent is that all dwelling units must have mechanical ventilation unless they can meet the blower door test requirements of the IECC. This is not always how this section has been interpreted and therefore this proposal is sought as a clarification. See attached previous code change proposal for the original intent. Additionally, the 2012 IBC Significant Code Change documentation regarding the subject matter. Both attachments substantiate that the provisions are intended to apply to all dwelling units, not just dwelling units in residential buildings (3 stories or less) as defined by the IECC.

Also note that a formal interpretation regarding this matter was requested; however, it remained unresolved. See attached comments regarding the request.

1203.1

Mechanical Ventilation Required

CHANGE TYPE: Addition

CHANGE SUMMARY: The option of natural ventilation rather than mechanical ventilation is now unavailable when a dwelling unit is tested using a blower door test and it is determined that an adequate number of air changes are not provided.

2012 CODE: 1203.1 General. Buildings shall be provided with natural ventilation in accordance with Section 1203.4, or mechanical ventilation in accordance with the *International Mechanical Code*.

Where the air infiltration rate in a dwelling unit is less than 5 air changes per hour when tested with a blower door at a pressure 0.2 inch w.c. (50 Pa) in accordance with Section 402.4.1.2 of the *International Energy Conservation Code*, the dwelling unit shall be ventilated by mechanical means in accordance with Section 403 of the *International Mechanical Code*.

CHANGE SIGNIFICANCE: As the building's thermal envelope gets tighter resulting in less outdoor air leaking into the building's interior, mechanical ventilation may be necessary to maintain the indoor air quality. For dwelling units, a measured cutoff point is provided and a reference is made to the applicable provisions of the *International Mechanical Code* for providing the necessary ventilation. It should be noted that the new text in the IBC does not require that a blower door test be conducted, but rather, acts on the results of any such test that is conducted. However, code users should be aware that Section 402.4.1.2 of the 2012 *International Energy Conservation Code* (IECC) does require that residential buildings conduct a blower door test to determine the amount of air leakage. Therefore, in jurisdictions that have adopted the IECC those blower door test results will be used to determine if the IBC requirement for a mechanical ventilation system is to be imposed. Because the IECC requires a maximum air leakage rate of 5 air changes per hour, any building other than those in Climate Zones 1 and 2 that have exactly 5 air changes per hour would need a mechanical ventilation system based on IBC Section 1203.1.

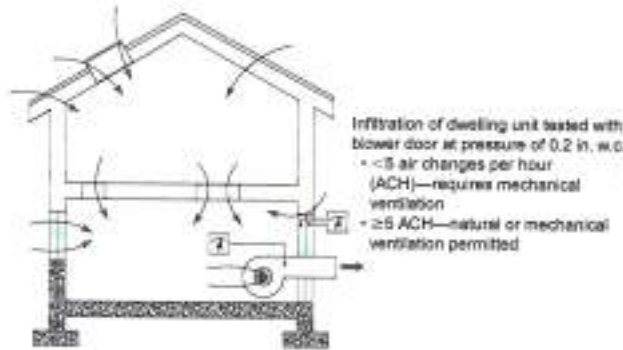

Blower door test determines air infiltration rate

Generally, the designer has a choice of either providing natural ventilation or mechanical ventilation. The option of using natural ventilation instead of mechanical ventilation is no longer permitted when the dwelling unit is tested using the blower door test and the infiltration level is below 5 air changes per hour (ACH). As building construction practices have improved, buildings have become tighter; as buildings become tighter, mechanical ventilation must be introduced to provide sufficient levels of ventilation to ensure indoor air quality. This 5-air-change requirement at the specified pressure provides a clear point to determine when infiltration is not adequate and must be supplemented by a mechanical system.

The 5 ACH limit was selected even though it is less than would generally be obtained by the IMC's requirement for 0.35 ACH of outdoor airflow for a dwelling using a mechanical ventilation system. By following the calculation procedures of the ASHRAE 136 standard, it can be shown that a natural infiltration rate of 0.35 ACH is equivalent to somewhere between 7 to 10 ACH at the specified pressure, depending on the local climatic conditions of the building. As fewer air changes are provided, the reliance on window operation is not sufficient and the concern for the effect on indoor air quality goes up. An additional source of justification for the 5 ACH limit is the National Association of Home Builder's (NAHB's) *National Green Building Standard* that requires whole-house mechanical ventilation when the infiltration rate falls below the 5 ACH value.

The actual effect of this change may be less than what it would first appear because most dwelling units do provide a mechanical ventilation system and do not rely on natural ventilation. If the dwelling unit is using a mechanical system, the IMC requires the necessary 0.35 ACH of outdoor airflow which is adequate for providing the proper ventilation.

Bibliography:

Significant Changes to the International Building Code, 2012 edition; Page 212

Cost Impact

The code change proposal will not increase or decrease the cost of construction .

This is a clarification and not a change, therefore, it will not increase nor decrease the cost of construction.

Internal ID: 3418

G117-18

IBC: 1202.1

Proponent: Daniel buck, JRS Engineering, representing Air Barrier Association of America (dbuck@jrseengineering.com)

2018 International Building Code

Revise as follows:

1202.1 General. Buildings shall be provided with natural ventilation in accordance with the International Mechanical Code.

~~Where the air infiltration rate in a *dwelling unit* is less than 5 air changes per hour where tested with a blower door at a pressure 0.2 inch w.c. (50 Pa) in accordance with Section R402.4.1.2 of the International Energy Conservation Code - Residential Provisions, the *dwelling unit*~~*Dwelling units* shall be ventilated by mechanical means in accordance with Section 403 of the International Mechanical Code. *Ambulatory care facilities* and Group I-2 occupancies shall be ventilated by mechanical means in accordance with Section 407 of the International Mechanical Code.

Reason:

This change clarifies the implications of the existing code language. Under current code, Dwelling Units in multi-unit buildings, to which this commercial code would apply, are not required to be tested in accord with the referenced Section R402.4.1.2 of the International Energy Conservation Code - Residential Provisions. It is therefore impossible for design professionals or code officials to determine if the Dwelling Unit must be vented mechanically, unless additional voluntary testing is conducted. This testing also comes after construction is completed and adding additional mechanical ventilation at that phase could be very costly. However, if dwelling units are required to be tested in accord with section R402.4.1.2, they must have a resulting air infiltration rate of less than 5 air changes per hour. Therefore, the existing code language requirement for mechanical ventilation applies to all Dwelling Units that would meet the residential code. Eliminating this language all together would preserve the effect of the code, while clarifying the intent, and eliminating the reference to testing which is not required.

Cost Impact

The code change proposal will not increase or decrease the cost of construction .

For jurisdictions that adopt both the IBC and IECC, there will be no cost impact from this proposed change to existing code provisions.

Internal ID: 1570

G118-18

IBC: 202 (New), 1202.3

Proponent: Mike Fischer, Kellen Company, representing The Asphalt Roofing Manufacturers Association (mfischer@kellencompany.com)

2018 International Building Code

Add new definition as follows:

VAPOR DIFFUSION PORT.

An assembly constructed or installed within a roof assembly at an opening in the roof deck to convey water vapor from an unvented attic to the outside atmosphere.

Revise as follows:

1202.3 Unvented attic and unvented enclosed rafter assemblies. Unvented attics and unvented enclosed roof framing assemblies created by ceilings applied directly to the underside of the roof framing members/rafters and the structural roof sheathing at the top of the roof framing members shall be permitted where all of the following conditions are met:

1. The unvented attic space is completely within the *building thermal envelope*.
2. No interior Class I vapor retarders are installed on the ceiling side (*attic floor*) of the unvented attic assembly or on the ceiling side of the unvented enclosed roof framing assembly.
3. Where wood shingles or shakes are used, not less than a 1/4-inch (6.4 mm) vented airspace separates the shingles or shakes and the roofing underlayment above the structural sheathing.
4. In Climate Zones 5, 6, 7 and 8, any air-impermeable insulation shall be a Class II vapor retarder or shall have a Class II vapor retarder coating or covering in direct contact with the underside of the insulation.
5. ~~Insulation shall be located in accordance with the following~~comply with Item 5.1 or 5.2, and additionally Item 5.3:
 - 5.1. Item 5.1.1, 5.1.2, 5.1.3 or 5.1.4 shall be met, depending on the air permeability of the insulation directly under the structural roof sheathing.
 - 5.1.1. Where only air-impermeable insulation is provided, it shall be applied in direct contact with the underside of the structural roof sheathing.
 - 5.1.2. Where air-permeable insulation is provided inside the building thermal envelope, it shall be installed in accordance with Item 5.1.1. In addition to the air-permeable insulation installed directly below the structural sheathing, rigid board or sheet insulation shall be installed directly above the structural roof sheathing in accordance with the R-values in Table 1202.3 for condensation control.
 - 5.1.3. Where both air-impermeable and air-permeable insulation are provided, the *air-impermeable insulation* shall be applied in direct contact with the underside of the structural roof sheathing in accordance with Item 5.1.1 and shall be in accordance with the R-values in Table 1202.3 for condensation control. The *air-permeable insulation* shall be installed directly under the *air-impermeable insulation*.
 - 5.1.4. Alternatively, sufficient rigid board or sheet insulation shall be installed directly above the structural roof sheathing to maintain the monthly average temperature of the underside of the structural roof sheathing above 45°F (7°C). For calculation purposes, an interior air temperature of 68°F (20°C) is assumed and the exterior air temperature is assumed to be the monthly average outside air temperature of the three coldest months.
 - 5.2. In climate zones 1, 2, and 3 where air-permeable insulation is installed in unvented attics it shall meet the following requirements: 1) An approved vapor diffusion port shall be installed not more than 12 inches (305mm) from the highest point of the roof, measured within the plane of the roof from the highest point of the roof to the lower edge of the port. 2) The port area shall be ≥ 1:600 of the ceiling area. Where there are multiple ports in the attic, the sum of the port areas shall be greater than or equal to the area requirement. The ports

shall be distributed equally throughout the attic space. 3) The vapor diffusion port shall include an approved vapor permeable and water-resistive membrane that is open to the outside air. The vapor permeable membrane in the vapor diffusion port shall have a vapor permeance rating of ≥ 20 perms when tested in accordance with Procedure A of ASTM E96. 4) The vapor diffusion port shall serve as an air barrier between the attic and the exterior of the building. 5) The vapor diffusion port shall protect the attic against the entrance of rain and snow. 6) Framing members and blocking shall not block the free flow of water vapor to the port. Not less than a 2-inch (50 mm) space shall be provided between any blocking and the roof sheathing. Air permeable insulation shall be permitted within that space. 7) The roof slope shall be $\geq 3:12$ (vertical/horizontal). 8) Where only air-permeable insulation is used, it shall be installed directly below the structural roof sheathing. 9) Air-impermeable insulation, if any, shall be directly above or below the structural roof sheathing and is not required to meet the R-value in Table 806.5. Where directly below the structural roof sheathing, there shall be no space between the air-impermeable and air-permeable insulation. 10) The air shall be supplied at a flow rate ≥ 50 CFM (23.6 L/s) per 1000 square foot of ceiling. The air shall be supplied from ductwork providing supply air to the occupiable space when the conditioning system is operating. Alternatively, the air shall be supplied by a supply fan when the conditioning system is operating.

5.3. Where preformed insulation board is used as the *air-impermeable insulation* layer, it shall be sealed at the perimeter of each individual sheet interior surface to form a continuous layer.

Exceptions:

1. Section 1202.3 does not apply to special use structures or enclosures such as swimming pool enclosures, data processing centers, hospitals or art galleries.
2. Section 1202.3 does not apply to enclosures in Climate Zones 5 through 8 that are humidified beyond 35 percent during the three coldest months.

Reason:

This proposal is the same as PC1 to RB 327-16, which was approved as submitted for the IRC. ARMA is concerned with the lack of detail regarding the vapor diffusion port in the IRC, and submitted this proposal to provide an option to improve the language for inclusion in the IBC with the thought to modify the IRC during group B. The risk of moisture damage to the roof deck, and subsequent issues with roof covering attachment should be addressed.

The proposal differs from the IRC as follows:

1. Modifies the definition of vapor diffusion port to clarify that it is an element of the attic space and is installed within the roof deck.
2. Provides guidance on the location of the vapor diffusion ports within the roof assembly.
3. States clearly that the vapor diffusion port contains a membrane material that is both vapor permeable and water resistive.

These modifications are consistent with the research report used as justification for the IRC provisions for air-permeable insulation in unvented attics. Without this change, the provisions lack appropriate detail to ensure proper performance.

Cost Impact

The code change proposal will decrease the cost of construction .

The proposal adds an optional insulation strategy to the IBC; it does not add any mandatory provisions.

Analysis: The standard referenced in this proposal, ASTM E96, is already referenced in the IBC.

Internal ID: 2390

G119-18

IBC: 202 (New), 1202.3

Proponent: Craig Conner, representing self (craig.conner@mac.com); Joseph Lstiburek, representing Self (joe@buildingsscience.com)

2018 International Building Code

Add new definition as follows:

VAPOR DIFFUSION PORT. An assembly constructed or installed within a roof assembly at an opening in the roof deck to convey water vapor from an unvented attic to the outside atmosphere.

Revise as follows:

1202.3 Unvented attic and unvented enclosed rafter assemblies. Unvented *attics* and unvented enclosed roof framing assemblies created by ceilings applied directly to the underside of the roof framing members/rafters and the structural roof sheathing at the top of the roof framing members shall be permitted where all of the following conditions are met:

1. The unvented *attic* space is completely within the *building thermal envelope*.
2. No interior Class I vapor retarders are installed on the ceiling side (*attic* floor) of the unvented *attic* assembly or on the ceiling side of the unvented enclosed roof framing assembly.
3. Where wood shingles or shakes are used, not less than a 1/4-inch (6.4 mm) vented airspace separates the shingles or shakes and the roofing underlayment above the structural sheathing.
4. In Climate Zones 5, 6, 7 and 8, any air-impermeable insulation shall be a Class II vapor retarder or shall have a Class II vapor retarder coating or covering in direct contact with the underside of the insulation.
5. ~~Insulation shall be located in accordance with the following:~~ Insulation shall comply with either Item 5.1 or 5.2, and additionally Item 5.3
 - 5.1. Item 5.1.1, 5.1.2, 5.1.3 or 5.1.4 shall be met, depending on the air permeability of the insulation directly under the structural roof sheathing.
 - 5.1.1. Where only air-impermeable insulation is provided, it shall be applied in direct contact with the underside of the structural roof sheathing.
 - 5.1.2. Where air-permeable insulation is provided inside the building thermal envelope, it shall be installed in accordance with Item 5.1.1. In addition to the air-permeable insulation installed directly below the structural sheathing, rigid board or sheet insulation shall be installed directly above the structural roof sheathing in accordance with the *R*-values in Table 1202.3 for condensation control.
 - 5.1.3. Where both air-impermeable and air-permeable insulation are provided, the *air-impermeable insulation* shall be applied in direct contact with the underside of the structural roof sheathing in accordance with Item 5.1.1 and shall be in accordance with the *R*-values in Table 1202.3 for condensation control. The *air-permeable insulation* shall be installed directly under the *air-impermeable insulation*.
 - 5.1.4. Alternatively, sufficient rigid board or sheet insulation shall be installed directly above the structural roof sheathing to maintain the monthly average temperature of the underside of the structural roof sheathing above 45°F (7°C). For calculation purposes, an interior air temperature of 68°F (20°C) is assumed and the exterior air temperature is assumed to be the monthly average outside air temperature of the three coldest months.
 - 5.2. In climate zones 1, 2, and 3 air-permeable insulation installed in unvented attics shall meet the following requirements:
 - 5.2.1. A vapor diffusion port shall be installed not more than 12 inches (305mm) from the highest point of the roof, measured vertically from the highest point of the roof to the lower edge of the port.
 - 5.2.2. The port area shall be \geq 1:600 of the ceiling area. Where there are multiple ports in the attic, the sum of the port areas shall be greater than or equal to the area

requirement.

- 5.2.3. The vapor permeable membrane in the vapor diffusion port shall have a vapor permeance rating of ≥ 20 perms when tested in accordance with Procedure A of ASTM E96.
 - 5.2.4. The vapor diffusion port shall serve as an air barrier between the attic and the exterior of the building.
 - 5.2.5. The vapor diffusion port shall protect the attic against the entrance of rain and snow.
 - 5.2.6. Framing members and blocking shall not block the free flow of water vapor to the port. Not less than a 2-inch (50 mm) space shall be provided between any blocking and the roof sheathing. Air-permeable insulation shall be permitted within that space.
 - 5.2.7. The roof slope shall be $\geq 3:12$ (vertical/horizontal).
 - 5.2.8. Where only air-permeable insulation is used, it shall be installed directly below the structural roof sheathing, on top the attic floor, or on top of the ceiling.
 - 5.2.9. Where only air-permeable insulation is used and is installed directly below the structural roof sheathing, air shall be supplied at a flow rate ≥ 50 CFM (23.6 L/s) per 1000 ft² of ceiling.
- 5.3. The air shall be supplied from ductwork providing supply air to the occupiable space when the conditioning system is operating. Alternatively, the air shall be supplied by a supply fan when the conditioning system is operating. Where preformed insulation board is used as the *air-impermeable insulation* layer, it shall be sealed at the perimeter of each individual sheet interior surface to form a continuous layer.

Exceptions:

1. Section 1202.3 does not apply to special use structures or enclosures such as swimming pool enclosures, data processing centers, hospitals or art galleries.
2. Section 1202.3 does not apply to enclosures in Climate Zones 5 through 8 that are humidified beyond 35 percent during the three coldest months.

Reason:

Unvented attic assemblies have a record of success. Airtight attics also benefit energy efficiency. Unvented attic assemblies are most commonly constructed with spray polyurethane foam applied directly to the underside of the roof deck. This is a historically successful method of construction with over 20 years of experience. Another approach to unvented attic assemblies is to insulate over the top of the roof deck with rigid insulation boards.

The proposed code change allows the use of lower cost alternatives. Specifically, the proposed code change allows the use of blown cellulose, fiberglass batts, and blown fiberglass to construct unvented attic assemblies. The approach is limited to Climate Zones 1, 2 and 3 based on research and historic experience over the past decade. The proposed code change adds a vapor diffusion port/vent. The port acts as a moisture control measure, allowing moisture in the attic to be removed by vapor diffusion rather than by air change. This allows the attic assembly to remain airtight while providing a path for vapor moisture via vapor diffusion.

This allows alternatives to rigid board and spray polyurethane foam. Alternatives provides more material choices for designers, builders and consumers and may provide less expensive options for unvented attics. This same change was approved for the IRC last code cycle. This also allows insulation to be above the ceiling or on the attic floor. With air permeable insulation the insulation can be installed directly to the underside of the roof deck or at the floor or ceiling level of an attic assembly as moisture laden air is more buoyant than dry air and therefore the moisture will accumulate at the ridge and exit via the vapor diffusion port.

This proposal improves upon the 2018 IRC text by adding additional detail on the vapor diffusion port, consistent with the research used as substantiation for the original IRC code change. It modifies the definition of vapor diffusion port to clarify that it is an element of the attic space and is installed within the roof deck. It also provides guidance on the location of the vapor diffusion ports within the roof assembly, and clarifies that the vapor diffusion port contains a membrane material that is both vapor permeable and water resistive.

Adding new unvented attic options to the existing options provides additional benefits. In high wildfire regions the elimination of eave vents and air sealing the upper attic vents at ridges reduces the entry of embers. In hurricane zones the elimination of roof vents reduces the entry of rainwater during hurricane events.

The research work supporting this code change is an outgrowth of the original research work supporting unvented attic assemblies started in 1995 under the Department of Energy's Building America Program. The same technical team and the same technical rigor that supported the original code changes for unvented attics in the early 2000's are behind this proposed code change.

The technical rationale and research behind this code change can be found at Venting Vapor:

<http://buildingscience.com/documents/insights/bsi-088-venting-vapor?topic=doctypes/insights>

For a history of conditioned attics, see Cool Hand Luke Meets Attics

<http://buildingscience.com/documents/insights/bsi-077-cool-hand-luke-meets-attics>

Additional technical data can be found at:

<https://buildingscience.com/documents/building-america-reports/ba-1511-fieldtesting-unvented-roof-fibrous-insulation-tiles-and>

And:

<https://buildingscience.com/documents/building-america-reports/ba-1409-field-testing-unvented-roofs-asphalt-shingles-cold-and>

Links to two full research reports are at the bottom of the pages on the web sites.

Cost Impact

The code change proposal will decrease the cost of construction .

This provides a new option for using additional insulation materials. In some cases those materials would reduce costs.

Analysis: The standard referenced in this proposal, ASTM E96, is already referenced in the IBC.

Internal ID: 1185

G120-18

IBC: SECTION 202, 202 (New), 1202.3

Proponent: Charles Haack, representing North American Insulation Manufacturers Association (chaack@naima.org)

2018 International Building Code

SECTION 202 DEFINITIONS

Add new text as follows:

VAPOR DIFFUSION PORT. A passageway for conveying water vapor from an unvented attic to the outside atmosphere.

Revise as follows:

1202.3 Unvented attic and unvented enclosed rafter assemblies. Unvented *attics* and unvented enclosed roof framing assemblies created by ceilings applied directly to the underside of the roof framing members/rafters and the structural roof sheathing at the top of the roof framing members shall be permitted where all of the following conditions are met:

1. The unvented *attic* space is completely within the *building thermal envelope*.
2. No interior Class I vapor retarders are installed on the ceiling side (*attic* floor) of the unvented *attic* assembly or on the ceiling side of the unvented enclosed roof framing assembly.
3. Where wood shingles or shakes are used, not less than a 1/4-inch (6.4 mm) vented airspace separates the shingles or shakes and the roofing underlayment above the structural sheathing.
4. In Climate Zones 5, 6, 7 and 8, any air-impermeable insulation shall be a Class II vapor retarder or shall have a Class II vapor retarder coating or covering in direct contact with the underside of the insulation.
5. Insulation shall ~~be located in accordance with the following~~ comply with Item 5.3 and either Item 5.1 or 5.2:
 - 5.1. Item 5.1.1, 5.1.2, 5.1.3 or 5.1.4 shall be met, depending on the air permeability of the insulation directly under the structural roof sheathing.
 - 5.1.1. Where only air-impermeable insulation is provided, it shall be applied in direct contact with the underside of the structural roof sheathing.
 - 5.1.2. Where air-permeable insulation is provided inside the building thermal envelope, it shall be installed in accordance with Item 5.1.1. In addition to the air-permeable insulation installed directly below the structural sheathing, rigid board or sheet insulation shall be installed directly above the structural roof sheathing in accordance with the *R-values* in Table 1202.3 for condensation control.
 - 5.1.3. Where both air-impermeable and air-permeable insulation are provided, the *air-impermeable insulation* shall be applied in direct contact with the underside of the structural roof sheathing in accordance with Item 5.1.1 and shall be in accordance with the *R-values* in Table 1202.3 for condensation control. The *air-permeable insulation* shall be installed directly under the *air-impermeable insulation*.
 - 5.1.4. Alternatively, sufficient rigid board or sheet insulation shall be installed directly above the structural roof sheathing to maintain the monthly average temperature of the underside of the structural roof sheathing above 45°F (7°C). For calculation purposes, an interior air temperature of 68°F (20°C) is assumed and the exterior air temperature is assumed to be the monthly average outside air temperature of the three coldest months.
 - 5.2. In Climate Zones 1, 2, and 3, air-permeable insulation installed in unvented attics shall meet the following requirements:
 - 5.2.1. An approved vapor diffusion port shall be installed not more than 12 inches (305 mm) from the highest point of the roof, measured vertically from the highest point of the roof to the lower edge of the port.
 - 5.2.2. The port area shall be greater than or equal to 1:600 of the ceiling area. Where there are multiple ports in the attic, the sum of the port areas shall be greater than

or equal to the area requirement.

- 5.2.3. The vapor-permeable membrane in the vapor diffusion port shall have a vapor permeance rating of greater than or equal to 20 perms when tested in accordance with Procedure A of ASTM E96.
- 5.2.4. The vapor diffusion port shall serve as an air barrier between the attic and the exterior of the building.
- 5.2.5. The vapor diffusion port shall protect the attic against the entrance of rain and snow.
- 5.2.6. Framing members and blocking shall not block the free flow of water vapor to the port. Not less than a 2-inch (51 mm) space shall be provided between any blocking and the roof sheathing. Air-permeable insulation shall be permitted within the space.
- 5.2.7. The roof slope shall be greater than or equal to 3:12 (vertical/horizontal).
- 5.2.8. Where only air-permeable insulation is used, it shall be installed directly below the structural roof sheathing.
- 5.2.9. Air-impermeable insulation, if any, shall be directly above or below the structural roof sheathing and is not required to meet the R-value in Table 806.5. Where directly below the structural roof sheathing, there shall be no space between the air-impermeable insulation and air-permeable insulation.
- 5.2.10. The air shall be supplied at a flow rate greater than or equal to 50 CFM (23.6 L/s) per 1,000 square feet (93 m²) of ceiling. The air shall be supplied from ductwork providing supply air to the occupiable space when the conditioning system is operating. Alternatively, the air shall be supplied by a supply fan when the conditioning system is operating.

- 5.3. Where preformed insulation board is used as the *air-impermeable insulation* layer, it shall be sealed at the perimeter of each individual sheet interior surface to form a continuous layer.

Exceptions:

- 1. Section 1202.3 does not apply to special use structures or enclosures such as swimming pool enclosures, data processing centers, hospitals or art galleries.
- 2. Section 1202.3 does not apply to enclosures in Climate Zones 5 through 8 that are humidified beyond 35 percent during the three coldest months.



Reason:

This exact code change has been approved and included in the 2018 International Residential Code and this proposal extends the same language to the International Building Code.

This proposal would expand the ability to use air-permeable insulation materials in Climate Zones 1, 2, and 3 supported by research and field testing during the past 10 years. The proposed code change allows the use of lower cost alternatives, including permitting the use of fiber glass, rock wool, or cellulose to construct unvented attic assemblies.

Unvented attic assemblies already have a record of success and unvented attic assemblies are most commonly constructed with spray polyurethane foam applied directly to the underside of the roof deck. This method of construction has over 20 years of documented successful implementation and experience. Another, but less common, approach to unvented attic assemblies is to insulate over the top of the roof deck with rigid insulation boards.

Unvented assemblies offer several benefits to builders and homebuyers including increased home energy efficiency, lower cost alternatives, and design flexibility. Unvented attic assemblies can reduce energy costs for homes with HVAC systems located in the attic by lowering the temperature of the air surrounding the system and reducing the loss of conditioned air to areas outside the conditioned space. Expanding the ability to use other materials including fiber glass, rock wool, and cellulose will increase competition and likely lower construction costs for unvented attic assemblies.

This proposed code change adds a vapor diffusion port/vent to the roof system. The port acts as a moisture control

measure, allowing moisture in the attic to be removed by vapor diffusion rather than by air change. This allows the attic assembly to remain airtight while providing a path for vapor moisture via vapor diffusion.

Adding new unvented attic options to the existing options provides additional benefits. In high wildfire regions, the elimination of eave vents and air sealing the upper attic vents at the ridges reduces the entry of embers. In hurricane zones, the elimination of roof vents reduces the entry of rainwater during hurricane events.

The research work supporting this code change is an outgrowth of the original research work supporting unvented attic assemblies started in 1995 under the Department of Energy's Building America program. The same technical team and the same technical rigor that supported the original code changes for unvented attics in the early 2000s are behind this proposed code change.

Bibliography:

Following is a list links to research reports and information for this code proposal: <http://www.buildingscience.com/documents/insights/bsi-088-venting-vapor?topic=doctypes/insights>

For a history of conditioned attics, see "Cool Hand Luke Does Attics": <http://buildingscience.com/documents/insights/bsi-077-cool-hand-luke-meets-attics>

For the technical data see: <http://buildingscience.com/documents/building-america-reports/ba-1409-field-testing-unvented-roofs-asphalt-shingles-cold-and> (NOTE: The link to the research report above is at the lower right of this webpage.)

http://buildingscience.com/sites/default/files/document/ba-1511_field_testing_of_unvented_roof_with_fibrous_insulation_tiles_and_vapor_diffusion_venting.pdf

Cost Impact

The code change proposal will not increase or decrease the cost of construction .

This proposal will not increase the cost of construction and will provide options to builders and designers.

Analysis: The standard referenced in this proposal, ASTM E96, is already referenced in the IBC.

Internal ID: 1237

G121-18

IBC: 1204.1

Proponent: Peter Valkov, City of Fargo, ND, representing City of Fargo, North Dakota (pvalkov@cityoffargo.com); Christine Rose, City of Fargo, representing City of Fargo (crose@cityoffargo.com)

2018 International Building Code

Revise as follows:

1204.1 General. Every space intended for human occupancy shall be provided with natural light by means of exterior glazed openings in accordance with Section 1204.2 or shall be provided with artificial light in accordance with Section 1204.3. Exterior glazed openings shall open directly onto a *public way* or onto a *yard* or *court* in accordance with Section 1205.

In Group E and I-4 occupancies, rooms intended to be used as classrooms or day care rooms shall be provided with natural light. Artificial light shall not be substituted for such required natural light.

Reason:

I am driven to propose this change on behalf of all little members of our society who cannot propose this change themselves.

Through my profession, I am reviewing many day care and school plans. Every time I see a classroom without windows, every time I see day care using an old building purposed for store or storage and hastily re-purposed for day care without any regard for the need of natural light (and this happens too often), I feel extremely sad. I am also very concerned that we as a society force our kids to places that have no natural light. We force them as they do not have choice, or say, or option to make a decision.

Researching the importance of natural light for the health and the intellectual development in little children gives me hope such a change is more than needed and possible, it is long overdue.

Having discussed my idea with colleagues in the City of Fargo and design professionals from the area also provided me with positive feedback. Architects, I have spoken to, also confirmed this change is possible from a design standpoint and it won't provide burden on the schools and day care facilities alike.

Therefore, today, I state my hope this change is made integral part of the building code as a part of our constant quest for healthier and safer buildings. Buildings that promote better and more natural environment for those amongst us that need it the most!

Bibliography:

1. <http://www.bristolite.com/blog/natural-light-and-education-the-benefits-of-daylighting-for-schools-and-colleges/>
2. <https://www.corbettinc.com/blog/2017/4/26/our-top-3-reasons-natural-light-benefits-students-schools>
3. <https://www.aia.org/articles/19541-six-design-decisions-that-will-entice-client:31>
4. <https://www.aia.org/press-releases/80866-aia-selects-2016-upjohn-research-initiative->
5. <http://www.healthyschools.org/downloads/Daylighting.pdf>
6. <https://globaldigitalcitizen.org/healthy-classrooms-infographic>
7. <http://www.sunlightinside.com/light-and-health/natural-light-improves-student-performance/>
8. <https://aia.aia.org/courses/aia2030-online-series-course-6-daylighting-and-integrated-lighting-design>
9. <https://www.google.com/search?safe=strict&biw=1381&bih=796&tbm=isch&sa=1&ei=aPITWsiIMqucjwTa5bHoCg&q=natural+light+schools&oq=natural+ab.3...33783.35478.0.36292.6.5.1.0.0.0.96.419.5.5.0....0...1c.1.64.psy-ab..0.0.0....0.EFczITCz0e8>
10. Bellia, L., A. Pedace, and G. Barbato, "Lighting in Educational Environments: An Example of A Complete Analysis of The Effecys of Daylighting and Electric Light on Occupants." Building and Environment 68 (2013): 50-65
11. Day, Christopher, and Anita Midjber. Environment and Children: Passive Lessons From the Everyday Environment. Oxford, UK: Architectural Press, 2007.
12. Demir, Ayse. "Impact of Daylighting on Student and Teacher Performance." Journal of Educational Instructional Studies in the World 3, no.1 (2013)
13. Heschong, Lisa, Roger L. Wright, and Stacia Okura. "Daylighting Impacts on Human Performance in School." Journal of the Illuminating Engineering Society 31, no.2 (2002): 101-114.

<http://www.tandfonline.com/doi/pdf/10.1080/00994480.2002.10748396#.UokrsG TF2TI>

14. <https://www.corbettinc.com/blog/2017/4/26/our-top-3-reasons-natural-light-benefits-students-schools>

Cost Impact

The code change proposal will not increase or decrease the cost of construction .

The need and requirement for windows is already a part of the International Building Code. Therefore, I do not foresee any changes in construction cost as a result from such a change.

Internal ID: 1578

G122-18

IBC: 1206.1

Proponent: Lee Kranz, representing Washington Association of Building Officials Technical Code Development Committee (lkranz@bellevuewa.gov)

2018 International Building Code

Revise as follows:

1206.1 Scope. This section shall apply to common interior walls, partitions and floor/ceiling assemblies between adjacent *dwelling units* and *sleeping units* or between *dwelling units* and *sleeping units* and adjacent public areas. ~~such as halls, corridors, stairways or service areas.~~

Reason:

There are building designs where a dwelling unit or sleeping unit in a mixed occupancy building may be adjacent to a commercial space where airborne and structure-borne sound is significant and may interrupt the occupants of the dwelling or sleeping unit unless the common interior walls, partitions and floor/ceiling assemblies are designed to limit sound transmissions to an acceptable level. This proposal deletes the examples currently listed at the end of Section 1206.1 which effectively broadens the scope of uses where sound abatement requirements can be enforced and provides the building official with authority to require sound abatement when appropriate. Occupants of the affected dwelling units and sleeping units may not realize that additional sound abatement has been provided but the quality of their lives will improve as a result.

Cost Impact

The code change proposal will increase the cost of construction .

This code change has the potential to increase the cost of construction because there may be a need to provide sound abatement between dwelling units or sleeping units and adjacent public areas.

Internal ID: 86

G123-18

IBC: 1206.2, Chapter 35

Proponent: Tim Earl, representing The Gypsum Association (tearl@gbhinternational.com)

2018 International Building Code

Revise as follows:

1206.2 Airborne sound. Walls, partitions and floor-ceiling assemblies separating *dwelling units* and *sleeping units* from each other or from public or service areas shall have a sound transmission class of not less than 50 where tested in accordance with ASTM E90, or not less than 45 if field tested ~~, for airborne noise where tested in accordance with ASTM E90.~~ ASTM E336, for airborne noise. Alternatively, the sound transmission class of walls, partitions and floor-ceiling assemblies shall be established by engineering analysis based on a comparison of walls, partitions and floor-ceiling assemblies having sound transmission class ratings as determined by the test procedures set forth in ASTM ~~E90.~~ E90. Penetrations or openings in construction assemblies for piping; electrical devices; recessed cabinets; bathtubs; soffits; or heating, ventilating or exhaust ducts shall be sealed, lined, insulated or otherwise treated to maintain the required ratings. This requirement shall not apply to entrance doors; however, such doors shall be tight fitting to the frame and sill.

ASTM

ASTM International
100 Barr Harbor Drive, P.O. Box
C700
West Conshohocken PA 19428-
2959
US

E336-17a:

Standard Test Method for Measurement of Airborne Sound Attenuation between Rooms in Buildings

Reason:

This change clarifies the appropriate ASTM test methods for airborne sound transmission. ASTM E90 is a laboratory measurement, and ASTM E336 is a field test. This proposal clarifies which test method to use.

Cost Impact

The code change proposal will not increase or decrease the cost of construction .

This change simply clarifies which test to use, with no impact on cost.

Analysis: A review of the standard proposed for inclusion in the code, ASTM E336 -17a, with regard to the ICC criteria for referenced standards (Section 3.6 of CP#28) will be posted on the ICC website on or before April 2, 2018.

Internal ID: 222

G124-18

IBC: 1206.2

Proponent: Michael Schmeida, Gypsum Association, representing Gypsum Association (mschmeida@gypsum.org)

2018 International Building Code

Revise as follows:

1206.2 Airborne sound. Walls, partitions and floor-ceiling assemblies separating *dwelling units* and *sleeping units* from each other or from public or service areas shall have a sound transmission class of not less than 50, or not less than 45 if field tested, for airborne noise where tested in accordance with ASTM E90. Alternatively, the sound transmission class of walls, partitions and floor-ceiling assemblies shall be established by an engineering analysis either conducted or reviewed by an approved acoustical professional based on a comparison of walls, partitions and floor-ceiling assemblies having sound transmission class ratings as determined by the test procedures set forth in ASTM E90. Penetrations or openings in construction assemblies for piping; electrical devices; recessed cabinets; bathtubs; soffits; or heating, ventilating or exhaust ducts shall be sealed, lined, insulated or otherwise treated to maintain the required ratings. This requirement shall not apply to entrance doors; however, such doors shall be tight fitting to the frame and sill.

Reason:

There are several engineering analysis tools for sound performance on the market. However, if the design professional is unfamiliar with acoustical engineering, they can be very misleading and therefore lead to a building performing under the expected performance levels. And as acoustical considerations are something most design professionals are not very familiar with at this point in time, the opportunity for error is above average. This change is intended to make sure that systems specified using the engineering analysis option are properly scrutinized by experts in acoustics and therefore are most likely going to perform as expected.

Cost Impact

The code change proposal will increase the cost of construction .

The estimated cost impact would be \$500. However, it should be pointed out that the engineering analysis is an option - there are other ways to meet the criteria of this section already mandated by the code where no additional cost would be incurred.

Internal ID: 565

G125-18

IBC: 1206.2, Chapter 35

Proponent: Michael Schmeida, representing Gypsum Association (mschmeida@gypsum.org)

2018 International Building Code

Revise as follows:

1206.2 Airborne sound. Walls, partitions and floor-ceiling assemblies separating *dwelling units* and *sleeping units* from each other or from public or service areas shall have a sound transmission class of not less than 50, or not less than 45 if field tested, for airborne noise where tested in accordance with ASTM E90. Alternatively, the sound transmission class of walls, partitions and floor-ceiling assemblies shall be established by engineering analysis based on a comparison of walls, partitions and floor-ceiling assemblies having sound transmission class ratings as determined by the test procedures set forth in ASTM E90. Penetrations or openings in construction assemblies for piping; electrical devices; recessed cabinets; bathtubs; soffits; or heating, ventilating or exhaust ducts shall be sealed, lined, insulated or otherwise treated to maintain the required ratings. Intersections between walls and floors and wall-to-wall intersections shall be sealed or otherwise treated in accordance to ASTM C919. This requirement shall not apply to entrance doors; however, such doors shall be tight fitting to the frame and sill.

Add new standard(s) follows:

ASTM

ASTM International
100 Barr Harbor Drive, P.O. Box
C700
West Conshohocken PA 19428-
2959
US

C919-12(2017):

Standard Practice for Use of Sealants in Acoustical Applications

Reason:

This change addresses sound flanking paths not previously addressed, requiring intersections to be sealed. If unsealed, these paths can reduce the effectiveness of walls by at least 5 STC points versus the tested systems. A differential of 3 STC points becomes perceptible by humans and 5 points is the threshold at which it becomes a nuisance. Sound intrusion via these unsealed intersections can cause noticeable deterioration in sound isolation performance.

Nuisance noise has a measurable impact on human health. A report by the World Health Organization on noise effects and morbidity linked "noise annoyance" (as it was called in the report) to increased risk for several health issues including arthritic symptoms, hypertension, and migraines.

The code already contains requirements for sound transmission, but by not addressing intersections, it leaves a sound transmission path which can negate the effects of other measures taken to reduce sound transmission.

The handbook of sound engineers states that "an acoustical sealant is required to caulk all joints of a partition if the highest TL (transmission loss) is to be attained."

This simple and relatively inexpensive step will ensure sound transmission performance in actual installations lives up to the expectations set by laboratory testing.

Bibliography:

WHO LARES Final Report, Noise Effects on Morbidity, Niemann and Maschke, Berlin Center for Public Health

Handbook for Sound Engineers, Jones, D. (2008), pp. 77-78

Noise Control Manual for Residential Buildings, Harris, D.A., (1997), pp. 73-76.

Cost Impact

The code change proposal will increase the cost of construction .

This proposal is estimated to add approximately \$20 per room requiring sealing to construction costs, for sealant and labor.

Analysis: A review of the standard proposed for inclusion in the code, ASTM C919-12(2017), with regard to the ICC

criteria for referenced standards (Section 3.6 of CP#28) will be posted on the ICC website on or before April 2, 2018.

Internal ID: 763

G126-18

IBC: 1206.3, Chapter 35

Proponent: Tim Earl, representing The Gypsum Association (tearl@gbhinternational.com)

2018 International Building Code

Revise as follows:

1206.3 Structure-borne sound. Floor-ceiling assemblies between *dwelling units* and *sleeping units* or between a *dwelling unit* or *sleeping unit* and a public or service area within the structure shall have an impact insulation class rating of not less than 50 where tested in accordance with ASTM E492, or have an apparent IIC (AIIIC) of not less than 45 if field tested, ~~where tested in accordance with ASTM E492-E1007~~. Alternatively, the impact insulation class of floor-ceiling assemblies shall be established by engineering analysis based on a comparison of floor-ceiling assemblies having impact insulation class ratings as determined by the test procedures in ASTM ~~E492-E492~~.

Add new standard(s) follows:

ASTM

ASTM International
100 Barr Harbor Drive, P.O. Box
C700
West Conshohocken PA 19428-
2959
US

E1007-16:

Test Method for Field Measurement of Tapping Machine Impact Sound Transmission Through Floor-Ceiling Assemblies and Associated Support Structures

Reason:

This change clarifies the appropriate ASTM test methods for airborne sound transmission. ASTM E492 is a laboratory measurement, and ASTM E1007 is a field test. This proposal clarifies which test method to use.

Cost Impact

The code change proposal will not increase or decrease the cost of construction .

This change simply clarifies which test to use, with no impact on cost.

Analysis: A review of the standard proposed for inclusion in the code, ASTM E1007-16, with regard to the ICC criteria for referenced standards (Section 3.6 of CP#28) will be posted on the ICC website on or before April 2, 2018.

Internal ID: 223

G127-18

IBC: 1207 (New), 1207.1 (New), 1207.2 (New), Chapter 35

Proponent: Dawn Anderson, representing self (gonedawning@yahoo.com); Dan Buuck, representing National Association of Home Builders (dbuuck@nahb.org); David Collins, representing the American Institute of Architects (dcollins@preview-group.com); Marsha Mazz, representing U.S. Access Board (mazz@Access-Board.gov); Dominic Marinelli, representing United Spinal Association (DMarinelli@accessibility-services.com)

2018 International Building Code

Add new text as follows:

SECTION 1207 ENHANCED CLASSROOM ACOUSTICS

1207.1 General. Enhanced classroom acoustics, where required in this section, shall comply with Section 808 of ICC A117.1.

1207.2 Where required. In Group E occupancies, enhanced classroom acoustics shall be provided in all classrooms with a volume of 20,000 cubic feet or less.

ICC

International Code Council, Inc.
500 New Jersey Ave NW 6th Floor
Washington DC 20001
US

ICC A117.1-092017:

Accessible and Usable Buildings and Facilities

Reason:

This proposal sets up a new section in the Chapter for Interior Environments; next to the section for sound transmission in residential occupancies. This section is proposed here and not in Chapter 11 because of the benefits of these provisions for all young children – thus following the codes history of mainstreaming’ requirements that may be related to accessibility, but apply broadly.

Research shows that good classroom acoustics are essential to support language acquisition and learning for all children, particularly younger children. For children who have hearing loss and those who use cochlear implants there is no substitute for a good acoustic environment. Assistive technologies typically only amplify the teacher and do not amplify discussions among children or between the teacher and individual child. Children with disabilities not related to hearing, such as autism and learning disabilities may be adversely affected by high ambient noise levels. Students that use a different language at home will also be able to listen more closely to fully understand the teacher and benefit from conversation among peers. Teachers report that a good acoustic environment actually assists in controlling the classroom, reducing the need to raise their voices, and promotes more civil behavior among students. Thus, good acoustic and low background noise in a classroom benefits everyone!

The standard size elementary classroom in the United States holds 25 to 30 students. Many states specify the minimum size at 700 sq.ft. – assuming 20 children in a room. The recommended size for a self-contained classroom is 800 to 960 sq.ft. for grade school; 700 to 840 sq.ft. for secondary school. Some researchers recommend up to 54 sq.ft. per child as optimum – 1620 sq.ft. for a 30 child classroom. Classrooms that are used for activities such as band, orchestra, choir or gym are significantly larger. Some lecture rooms in colleges are large enough to accommodate several hundred students.

The new technical criteria for classroom acoustics in the 2017 ICC A117.1 are limited to classrooms with a size under 20,000 cubic feet; assuming a 10 foot ceiling height, classrooms that are 2000 sq.ft. or less. While acoustics may be important to these larger classrooms, the criteria in ICC A117.1 Section 808 are intended to be applicable to standard size self-contained classrooms. This criteria are also not intended to apply to ancillary learning spaces, such as individual tutoring spaces, or other spaces where students may be, such as corridors or cafeterias.

Technical criteria includes a maximum reverberation time – achieved through either a performance or prescriptive method. The criteria also considers other sound sources – ambient sound and sound sources inside and outside the classrooms.

Cost Impact

The code change proposal will increase the cost of construction .

There will be acoustic requirements for classrooms, but not all spaces in new schools. Since this encompasses such a

broad range of options to comply, the cost may be limited to design choices. The work group intends to propose an exception for existing classrooms during Group B cycle.

Analysis: The 2009 edition of the ICC A117.1 standard is referenced in Chapter 35.

Internal ID: 554

G128-18

IBC: 1207.4

Proponent: Micah Chappell, representing City of Seattle (micah.chappell@seattle.gov)

2018 International Building Code

Revise as follows:

1207.4 Efficiency dwelling units. An efficiency living unit shall conform to the requirements of the code except as modified herein:

1. The unit shall have a living room of not less than 220 square feet (20.4 m²) of floor area. ~~An additional 100 square feet (9.3 m²) of floor area shall be provided for each occupant of such unit in excess of two.~~
2. The unit shall be provided with a separate closet.
3. The unit shall be provided with a kitchen sink, cooking appliance and refrigeration facilities, each having a clear working space of not less than 30 inches (762 mm) in front. Light and *ventilation* conforming to this code shall be provided.
4. The unit shall be provided with a separate bathroom containing a water closet, lavatory and bathtub or shower.

Reason:

Since there is no code path that calculates an occupant load exceeding two occupants unless the gross square footage of the efficiency dwelling unit exceeds 400 square feet, this language is not needed or enforceable.

Cost Impact

The code change proposal will not increase or decrease the cost of construction .

No cost impact.

Internal ID: 1836

G129-18

IBC: 1207.4

Proponent: Micah Chappell, representing City of Seattle (micah.chappell@seattle.gov)

2018 International Building Code

Revise as follows:

1207.4 Efficiency dwelling units. An efficiency living unit shall conform to the requirements of the code except as modified herein:

1. The unit shall have a living room of not less than ~~220~~190 square feet (~~20.4~~17.7 m²) of floor area. An additional 100 square feet (9.3 m²) of floor area shall be provided for each occupant of such unit in excess of two.
2. The unit shall be provided with a separate closet.
3. The unit shall be provided with a kitchen sink, cooking appliance and refrigeration facilities, each having a clear working space of not less than 30 inches (762 mm) in front. Light and *ventilation* conforming to this code shall be provided.
4. The unit shall be provided with a separate bathroom containing a water closet, lavatory and bathtub or shower.

Reason:

This proposal changes the living room/habitable space requirement of an efficiency dwelling unit to 190 square feet of floor area, so it is aligned and consistent with the requirements of a dwelling unit's net floor area per IBC Section 1207.3.

An efficiency dwelling unit is required to have more habitable space, more amenities, and a limit on occupants without providing additional floor area compared to a dwelling unit, when the only difference is the area configuration. When the occupant load of an efficiency dwelling unit is calculated indicating an excess of two occupants triggering the additional floor area requirement, there are no corresponding requirements for a dwelling unit of smaller square footage to provide additional space.

IBC Unit Standards:

Unit Type	Single Room	Other Habitable Rooms	Natural Light	Cooking	Sanitation Facility	Closet
Dwelling Unit	≥ 120 SF net floor area	≥ 70 SF* net floor area	Yes*	Yes Cooking facility/not defined	Yes	No
Efficiency Dwelling Unit	≥ 220 SF	N/A	Yes*	Yes Kitchen sink, cooking appliance, and refrigeration facilities	Yes required to be separate	Yes

*IBC allows an exception.

Cost Impact

The code change proposal will not increase or decrease the cost of construction .

This proposal will provide a cost benefit by reducing construction expense through allowing smaller square footage standards for efficiency dwelling units.

Internal ID: 1806

G130-18 Part I

IBC: 1207.4

Proponent: Ed Kullik, representing ICC Building Code Action Committee (bcac@iccsafe.org)

THIS IS A 2 PART CODE CHANGE PROPOSAL. PART I WILL BE HEARD BY THE GENERAL CODE DEVELOPMENT COMMITTEE. PART II WILL BE HEARD BY THE PROPERTY MAINTENANCE CODE COMMITTEE. SEE THE TENTATIVE HEARING ORDERS FOR THESE COMMITTEES.

2018 International Building Code

Revise as follows:

1207.4 Efficiency dwelling units. An efficiency ~~living-dwelling~~ unit shall conform to the requirements of the code except as modified herein:

1. The unit shall have a living room of not less than ~~220-190~~ square feet (~~20.4-17.6~~ m²) of floor area. An additional ~~100-70~~ square feet (~~9.3-6.5~~ m²) of floor area shall be provided for each occupant of such unit in excess of two.
2. The unit shall be provided with a separate closet.
3. ~~The~~ For other than Accessible, Type A and Type B dwelling units, the unit shall be provided with a kitchen sink, cooking appliance and ~~refrigeration facilities~~ refrigerator, each having a clear working space of not less than 30 inches (762 mm) in front. Light and *ventilation* conforming to this code shall be provided.
4. The unit shall be provided with a separate bathroom containing a water closet, lavatory and bathtub or shower.

Internal ID: 1579

G130-18 Part II

IPMC: 404.6

Proponent: Ed Kullik, representing ICC Building Code Action Committee (bcac@iccsafe.org)

2018 International Property Maintenance Code

Revise as follows:

404.6 Efficiency unit. Nothing in this section shall prohibit an efficiency ~~living~~ dwelling unit from meeting the following requirements:

1. A unit occupied by not more than one occupant shall have a minimum clear floor area of 120 square feet (11.2 m²). A unit occupied by not more than two *occupants* shall have a minimum clear floor area of ~~220-190~~ square feet (~~20.4-17.6~~ m²). A unit occupied by three *occupants* shall have a minimum clear floor area of ~~320-260~~ square feet (~~29.7-24.1~~ m²). These required areas shall be exclusive of the areas required by Items 2 and 3.
2. The unit shall be provided with a kitchen sink, cooking appliance and refrigeration facilities, each having a minimum clear working space of ~~30-40~~ inches (~~762-990~~ mm) in front. Light and *ventilation* conforming to this code shall be provided.

Exception:Dwelling units not required to be Accessible units, Type A units and Type B units shall have a clear working space of not less than 30 inches (762 mm) in front of the kitchen sink, cooking appliacne and refrigerator.
3. The unit shall be provided with a separate *bathroom* containing a water closet, lavatory and bathtub or shower.
4. The maximum number of *occupants* shall be three.

Reason:

The market is trending toward smaller living areas in multi-family R-2 structures particularly in urban areas. US Census statistics show that in 2000, app. 46,000 rental units built were less than 1,000 sq.ft. In 2015, 114,000 units and in 2016, 99,000 units were less than 1,000 sq.ft. The Urban Land Institute reported in 2013 that major Municipalities including New York City, San Francisco, Boston, Dallas and Philadelphia are allowing smaller apartments with Seattle and Portland (OR) having no minimum sizes. The proposed reduction allows for a modest decrease (13.6%) in the required living room area and (30%) in the floor area for each occupant of such unit in excess of two. Code Professionals are receiving proposals for dwelling units in R2 structures that are nonconforming with the minimum standards in the IBC.

The Room Area standard for dwelling units in BOCA and SBBC as well as the 2000 edition of IBC required that one room must have a minimum floor area of 150 sq.ft. This was reduced to 120 sq.ft in the 2003 IBC and remains today. The minimum living room area for efficiency units in the 2000 IBC is the same as the 2018 IBC. No reduction has been proposed even though the overall dwelling unit room area standard has been reduced. The proposal complies with the current language in IBC Section 1207.3. which requires that habitable rooms be at least 120 sq.ft.

IBC 1207.4: The change from "living unit" to "dwelling unit" is to use a defined term to describe these efficiency apartments. The change in Item 3 corrects potential existing conflicts with Chapter 10 of ICC A117.1. which requiring a clear working space of 40 inches in front of the kitchen sink, cooking appliance and refrigerator for Accessible, Type A or B units. The change from "refrigeration facilities" to "refrigerator" is to use a more clearly understood term, and eliminate someone believing that another type of fixture, such as a beer cooler, would be sufficient.

IPC 404.6: The changes to the IPC are for coordination with the revisions to the IBC for efficiency apartments.

This proposal is submitted by the ICC Building Code Action Committee (BCAC). BCAC was established by the ICC Board of Directors in July 2011 to pursue opportunities to improve and enhance assigned International Codes or portions thereof. In 2017 the BCAC has held 3 open meetings. In addition, there were numerous Working Group meetings and conference calls for the current code development cycle, which included members of the committee as well as any interested party to discuss and debate the proposed changes. Related documentation and reports are posted on the BCAC website at: <https://www.iccsafe.org/codes-tech-support/codes/code-development-process/building-code-action-committee-bcac>.

Cost Impact

The code change proposal will decrease the cost of construction .

This proposal could decrease the cost of construction where efficiency apartments are built to the lower minimum sizes required by the text that is proposed.

Internal ID: 3398

G131-18

IBC: SECTION 202, 202 (New), 1207.4

Proponent: Lee Kranz, representing Washington Association of Building Officials Technical Code Development Committee (lkranz@bellevuewa.gov)

2018 International Building Code

SECTION 202 DEFINITIONS

Add new definition as follows:

DWELLING UNIT, EFFICIENCY. A dwelling unit where all permanent provisions for living, sleeping, eating and cooking are contained in a single room.

Revise as follows:

1207.4 Efficiency dwelling units. ~~An efficiency living unit~~ Efficiency dwelling units shall conform to the requirements of the code except as modified herein:

1. The unit shall have a living room of not less than 220 square feet (20.4 m²) of floor area. An additional 100 square feet (9.3 m²) of floor area shall be provided for each occupant of such unit in excess of two.
2. The unit shall be provided with a separate closet.
3. The unit shall be provided with a kitchen sink, cooking appliance and refrigeration facilities, each having a clear working space of not less than 30 inches (762 mm) in front. Light and *ventilation* conforming to this code shall be provided.
4. The unit shall be provided with a separate bathroom containing a water closet, lavatory and bathtub or shower.

Reason:

Efficiency dwelling units are regulated in IBC Section 1207.4. Currently there is no definition of efficiency dwelling unit found in the code which may create inconsistency in the enforcement of these provisions. Many design professionals and building officials have assumed that efficiency dwelling units are studio apartments having only one habitable room, a closet, restroom and facilities for cooking. This code change will provide the needed definition so consistent enforcement and understanding will be achieved. There are no substantive changes proposed other than adding this definition.

Cost Impact

The code change proposal will not increase or decrease the cost of construction .

Clarrification only; no substantive changes are proposed so cost will remain the same as the current code.

Internal ID: 235

G132-18

IBC: [P]1209.3

Proponent: Gary Schenk, City of SeaTac, WA, representing Washington Association of Building Officials (gschenk@ci.seatac.wa.us); Lee Kranz, City of Bellevue, representing Washington Association of Building Officials Technical Code Development Committee (LKranz@bellevuewa.gov)

THIS PROPOSAL WILL BE HEARD BY THE INTERNATIONAL PLUMBING CODE COMMITTEE. SEE THE IPC-IPSDC HEARING ORDER.

2018 International Building Code

Revise as follows:

[P] 1209.3 Privacy. Public restrooms shall be visually screened from outside entry or exit doorways to ensure user privacy within the restroom. This provision shall also apply where mirrors would compromise personal privacy. Privacy at water closets and urinals shall be provided in accordance with Sections 1209.3.1 and 1209.3.2.

Exception: Visual screening shall not be required for single-occupant toilet rooms with a lockable door.

Reason:

Although this section currently has provisions for sidewall or partition urinal privacy within the restrooms, it does not address privacy from viewing the user at the fixture from outside of the restroom. It also addresses the placement of mirror reflection from the outside.

Cost Impact

The code change proposal will not increase or decrease the cost of construction .

This would be a design feature and would not increase the cost of construction. Minimal design should be necessary.

Internal ID: 1961

G133-18

IBC: 1209.3.1, 1209.3.1.1 (New)

Proponent: Eirene Knott, representing Metropolitan Kansas City Chapter of the ICC (Eirene.Knott@brrarch.com)

2018 International Building Code

[P] 1209.3.1 Water closet compartment. Each water closet utilized by the public or employees shall occupy a separate compartment with walls or partitions and a door enclosing the fixtures to ensure privacy.

Exceptions:

1. Water closet compartments shall not be required in a single-occupant toilet room with a lockable door.
2. Toilet rooms located in child day care facilities and containing two or more water closets shall be permitted to have one water closet without an enclosing compartment.
3. This provision is not applicable to toilet areas located within Group I-3 occupancy housing areas.

Add new text as follows:

1209.3.1.1 Water closet compartment size. Where a compartment is provided, the compartment shall be not less than 30 inches (762 mm) in width and not less than 60 inches (1524 mm) in depth for floor-mounted water closets and not less than 30 inches (762 mm) in width and 56 inches (1422) in depth for wall-hung water closets. The compartment shall provide not less than 21 inches (533 mm) of clearance in front of the water closet to any wall, fixture or door.

Reason:

This proposal is bringing language from the IPC into the IBC where designers that utilize the IBC can find this information more readily. Most architectural firms do not have an IPC in their office, but rather rely upon the IBC to provide the information needed for the design aspect of the project. This code change brings language directly from the IPC with specifics that will be utilized by a designer so that the toilet room layout will comply with the requirements of the IPC.

There is specific information in the IBC on the requirements for urinal partitions, so bringing language in specific to the toilet partitions would be a natural supplement to the information already provided

Cost Impact

The code change proposal will not increase or decrease the cost of construction .

This is just adding language that already exists in the IPC so this will not impact the construction cost.

Analysis: This is a [P] controlled section. This is a matter of IBC-G Committee deciding whether it is appropriate to have the same language contained in the IPC placed in the IBC. Technical changes to this section should not be made by IBC-G.

Internal ID: 490

G134-18

IBC: 1209.3.1

Proponent: Todd Snider, West Coast Code Consultants (WC3), representing Self (Todd@KimballEng.com)

THIS PROPOSAL WILL BE HEARD BY THE INTERNATIONAL PLUMBING CODE COMMITTEE. SEE THE IPC-IPSDC HEARING ORDER.

2018 International Building Code

[P] 1209.3.1 Water closet compartment. Each water closet utilized by the public or employees shall occupy a separate compartment with walls or partitions and a door enclosing the fixtures to ensure privacy. The walls or partitions shall begin at a height not more than 12 inches from and extend not less than 72 inches above the finished floor surface.

Exceptions:

1. Water closet compartments shall not be required in a single-occupant toilet room with a lockable door.
2. Toilet rooms located in child day care facilities and containing two or more water closets shall be permitted to have one water closet without an enclosing compartment.
3. This provision is not applicable to toilet areas located within Group I-3 occupancy housing areas.

Reason:

Proposed revision to clarify privacy requirements for water closet compartment walls. Urinal partition walls have minimum dimensions but no dimensions have been provided for water closet partitions. This proposes to add requirements which will mirror the requirements for urinal partitions.

Cost Impact

The code change proposal will not increase or decrease the cost of construction .

This new requirement should not add cost. It seems that often this requirement is followed, but seems important to add as a requirement.

Internal ID: 1302

G135-18

IBC: Chapter 12, 1201.1, SECTION 1210 (New), 1210.1 (New), 1210.2 (New), 1210.2.1 (New), 1210.2.2 (New), 1210.2.3 (New), 1210.2.4 (New), 1210.2.5 (New), 1210.2.6 (New), 1210.2.7 (New), 1210.2.8 (New), 2010.2.9 (New), 1210.2.10 (New), 1210.2.11 (New), 1210.3 (New), 1210.3.1 (New), 1210.3.2 (New), 1210.3.3 (New), 1210.3.4 (New), 1210.3.5 (New), TABLE 1210.3 (New), 1210.3.6 (New), 1210.3.7 (New)

Proponent: Craig Conner, representing self (craig.conner@mac.com); Jani Palmer, representing Environmental Protection Agency (Palmer.Janise@epa.gov)

2018 International Building Code

CHAPTER 12 INTERIOR ENVIRONMENT

Revise as follows:

1201.1 Scope. The provisions of this chapter shall govern ventilation, temperature control, lighting, *yards* and *courts*, sound transmission, room dimensions, surrounding materials ~~and~~, rodentproofing associated with the interior spaces of ~~buildings~~buildings, and radon.

Add new text as follows:

SECTION 1210 RADON

1210.1 Applicability. Section 1210 shall apply to use groups E and I located in radon zone 1 as defined in IRC Table AF101(1).

Exception:Compliance with Section 1210 shall not be required where the authority having jurisdiction has defined the radon zone as Zone 2 or 3.

1210.2 Radon testing. Radon testing shall be performed in accordance with Sections 1210.2.1 through 1210.2.11.

1210.2.1 Airtightness. Testing shall be performed after the building passes its airtightness test.

1210.2.2 Fan. Where the system includes a fan, testing shall be performed after the radon control system installation is complete and operating with the fan.

1210.2.3 Lowest level. Testing shall be performed at the lowest level that will be occupied, inclusive of unfinished spaces. Spaces that are physically separated and severed by different HVAC systems shall be tested separately.

1210.2.4 Spaces not tested. Testing shall not be performed in a closet, hallway, stairway, laundry room, furnace room, bathroom or kitchen.

1210.2.5 Test kits and monitors. Testing shall be performed with a commercially available test kit or with a continuous radon monitor that can be calibrated. Testing with test kits shall include two tests, which shall be averaged. Testing shall be in accordance with the testing device manufacturer's instructions.

1210.2.6 Testing agency. Testing shall be performed by the builder, a registered design professional or an approved third party.

1210.2.7 Time period. Testing shall extend at least 48 hours or to the minimum specified by the testing device manufacturer, which ever is longer. This initial testing shall be permitted to extend past occupancy.

1210.2.8 Test results. Test results shall be provided directly to the owner by the test lab or testing party. The test results shall be delivered before or after occupancy.

2010.2.9 Additional test kit. An additional pre-paid test kit shall be provided to the owner to use when they choose. The test kit shall include mailing, or emailing the results from the testing lab to the owner. The builder shall also be permitted to receive the test results.

1210.2.10 Test result. This section does not require a specific test result, rather it requires the test be performed and the results be provided to the registered design professional or owner.

1210.2.11 Test result report. The registered design professional or owner shall be informed prior to occupancy and in writing that "A radon test result of 4 pCi/L or above is the 'action level' set by the U.S. Environmental Protection Agency (EPA. EPA recommends radon reduction measures to lower radon levels below 4 pCi/L." Or "For a radon test result of 4 pCi/L or above [name of builder or jurisdiction having authority] recommends radon reduction measures to lower radon levels below 4 pCi/L."

1210.3 Radon reduction measures. Radon reduction measures shall be in accordance with Sections 1210.3.1 through 1210.3.6 and Table 1210.3.

1210.3.1 Soil-gas barriers and base course. A base course in accordance with Section 1805.4.1 shall be installed below slabs and foundations. There shall be a continuous base course under each soil-gas retarder that is separated by foundation walls or footings. Foundation walls and floors in contact with the soil shall be damp proofed or waterproofed in accordance with Section 1805. Punctures, tears and gaps around penetrations of the soil-gas retarder shall be repaired or covered with an additional soil-gas retarder. The soil-gas retarder shall be a continuous 6-mil (0.15 mm) polyethylene or an approved equivalent. Approved alternative soil gas collection areas, such as sealed crawlspaces, shall be permitted.

1210.3.2 Soil gas collection. There shall be an unobstructed path for soil gas flow within the base course and out through the vent in the roof. Soil gases below the foundation shall be collected by a perforated pipe with a diameter of not less than 4 inches (10 cm) and not less than 10 ft (3 m) in total length that is mechanically fastened to a tee with two horizontal openings within the base course for radon collection or an equivalent method. The tee fitting connection within the base course and the soil gas vent pipe that extends to the roof shall be designed to prevent clogging of the radon collection path. Alternately the soil gas collection shall be by approved radon collection mats or an equivalent approved method.

1210.3.3 Soil gas entry routes. Openings in slabs, soil-gas retarders, and joints such as plumbing, ground water control systems, soil-gas vent pipes, piping and structural supports, shall be sealed against air leakage at the penetrations with a polyurethane caulk, expanding foam or other approved sealing method. Gaps, seams and joints below grade in walls and footings that surround soil gas collection areas shall be closed with cementitious materials, damp proofing, or other approved products. Closure shall be provided to prevent air migration between the base course that serves soil gas collection and exterior foundation drain systems located outside of the walls or footings that surround the soil gas collection areas. Masonry unit walls below grade shall provide a barrier between soil gas and interior spaces, including but not limited to, barriers within the hollow masonry units, full grouting, solid masonry units or other approved method. Sumps intended for ground water control shall have gasketed lids or be otherwise sealed and shall not be connected to the soil-gas exhaust system.

1210.3.4 Soil gas vent. A gas-tight vent pipe not less than 3 to 4 inches in diameter shall extend from the soil-gas permeable layer through the roof. Alternately, the vent shall extend from the soil-gas permeable layer to at least 30 feet above grade and shall not be less than 4 feet vertically above or 10 feet horizontally away from operable windows, doors or skylights. The vent pipe shall be sloped to avoid collecting condensate or rainwater. The vent pipe size shall not be reduced at any location as it goes from gas collection to the roof. Exposed and visible interior vent pipes shall be identified with not less than one label reading "Radon Reduction System" on each floor and in habitable attics.

1210.3.5 Vent pipe diameter. The minimum vent pipe diameter shall be as specified in Table 1210.3.5.

TABLE 1210.3.5
Maximum Vented Foundation Area

Maximum Area Vented	Minimum Pipe Diameter
<u>2,500 ft² (232 m²)</u>	<u>3 inch (7.6 cm)</u>
<u>4,000 ft² (372 m²)</u>	<u>4 inch (10 cm)</u>
<u>Unlimited</u>	<u>6 inch (15.2 cm)</u>

1210.3.6 Multiple vented areas. In dwellings where interior footings or other barriers separate the soil- gas permeable layer, each area shall be fitted with an individual vent pipe. Vent pipes shall connect to a single vent that terminates above the roof or individual vent pipes shall terminate separately above the roof.

1210.3.7 Fan. Each sub-slab soil-gas exhaust system shall include a fan, or dedicated space for the post-construction installation of a fan. The electrical supply for the fan shall be located within 6 feet (1.8 m) of the fan.

Reason:

Radon in schools presents a significant health risk. Thousands of schools are affected by radon. EPA found that 41% of schools that had high radon were located geographically within Zone 1 (high radon potential), It is common knowledge that there is no way to know your building's radon level unless you test. Post-construction mitigation is very expensive; preventative measures, such as adding radon reducing features during construction, can save future costs and lives.

Cost Impact

The code change proposal will increase the cost of construction .

The cost of three test kits with prepaid analysis and prepaid postage is less than \$80, probably less than \$50 in builder quantity including tax. Where there were multiple spaces that are physically separated and served by different HVAC systems each space would incur that cost.

The cost of the measures in the building varies widely with building size. Many elements of the radon resistant features are already required by code; for example, the base coarse under the foundation, and air tightness for the building; these would not add cost for the radon system.

Internal ID: 1794

G136-18

IBC: 202, 503.1.4, 1510.2.2

Proponent: Ed Kullik, Chair, representing ICC Building Code Action Committee (bcac@iccsafe.org)

2018 International Building Code

SECTION 202 DEFINITIONS

Revise as follows:

[BG] PENTHOUSE. An enclosed, unoccupied rooftop structure used for sheltering mechanical and electrical equipment, tanks, elevators and related machinery, stairways and vertical shaft openings.

503.1.4 Occupied roofs. A roof level or portion thereof shall be permitted to be used as an occupied roof provided the occupancy of the roof is an occupancy that is permitted by Table 504.4 for the story immediately below the roof. The area of the occupied roofs shall not be included in the *building area* as regulated by Section 506. An occupied roof shall not be included in the building height or number of stories as regulated by Section 504 provided the penthouses and other enclosed roof structures comply with Section 1510.

Exceptions:

1. The occupancy located on an occupied roof shall not be limited to the occupancies allowed on the *story* immediately below the roof where the building is equipped throughout with an *automatic sprinkler system* in accordance with Section 903.3.1.1 or 903.3.1.2 and occupant notification in accordance with Section 907.5 is provided in the area of the occupied roof.
2. Assembly occupancies shall be permitted on roofs of open parking spaces of Type I or Type II construction, in accordance with the exception to Section 903.2.1.6.

SECTION 1510 ROOFTOP STRUCTURES

[BG] 1510.1 General. The provisions of this section shall govern the construction of rooftop structures.

1510.1.1 Area limitation. The aggregate area of penthouses and other enclosed rooftop structures shall not exceed one-third the area of the supporting roof deck. Such penthouses and other enclosed rooftop structures shall not be required to be included in determining the building area or number of stories as regulated by Section 503.1. The area of such penthouses shall not be included in determining the fire area specified in Section 901.7.

[BG] 1510.2 Penthouses. Penthouses in compliance with Sections 1510.2.1 through 1510.2.5 shall be considered as a portion of the story directly below the roof deck on which such penthouses are located. Other penthouses shall be considered as an additional story of the building.

[BG] 1510.2.1 Height above roof deck. Penthouses constructed on buildings of other than Type I construction shall not exceed 18 feet (5486 mm) in height above the roof deck as measured to the average height of the roof of the penthouse. Penthouses located on the roof of buildings of Type I construction shall not be limited in height.

Exception: Where used to enclose tanks or elevators that travel to the roof level, penthouses shall be permitted to have a maximum height of 28 feet (8534 mm) above the roof deck.

[BG] 1510.2.2 Use limitations. Penthouses shall not be used for purposes other than the shelter of mechanical or electrical equipment, tanks, elevators and related machinery, stairways or vertical shaft openings in the roof ~~assembly~~ assembly, including ancillary spaces used to access elevators and stairways.

Reason:

This is part of a series of 3 proposals dealing with occupied roofs. See BCAC proposals to Section 1006 and 1009.

Although it was felt the original intent of the egress associated with occupied roofs was clear, we felt there were a few remaining provisions that left doubt as to what was intended. It had been reported that some code officials had interpreted the existing code provision to treat an unoccupied roof as an additional story so as to decrease the actual allowable stories in Chapter 5. To clarify that occupied roofs are not considered stories and are permitted to be used provide that egress is provided in accordance with all applicable sections of the IBC and IFC purposes in a manner “as if they were a story” without applying other “story” requirements like those associated with height and area limitations in Chapter 5 or fire area provisions of Chapter 9, we propose the above modifications as summarized below:

In Section 202, the definition of “PENTHOUSE” is proposed to be modified by adding the word “stairway”. This reinforces the existing and proposed language in Section 1510 that excludes certain allowable rooftop structures from being considered additional stories. The definition was not modified to include vestibule type areas as this is addressed in the proposed change to Section 1510.2.2.

The proposal in Section 503.1.4 Occupied roofs, adds a clarifying statement to support the concept that occupied roofs and other enclosed structures in Section 1510 are not an additional story.

Proposed modifications to Section 1510 Rooftop Structures include the additions of the word “Stairways” and the term, including ancillary spaces used to access elevators and stairways.” to Section 1510.2.2. Use Limitations.

As flat/ low-slope rooftops are increasingly, and intentionally, being designed and utilized for occupancies similar to those on occupied floor levels below, modifications to the current code are necessary to define rooftop structures that are occupied and ancillary to approved occupied roof uses and to clarify that these structures must comply with means of egress requirements, but are not a story for height and area limitations. In addition, the proposed modifications described above align the limitations for Occupied roof ancillary structures with those for penthouses as a reasonable approach based upon the shared characteristics of the two structure types.

This proposal is submitted by the ICC Building Code Action Committee (BCAC). BCAC was established by the ICC Board of Directors in July 2011 to pursue opportunities to improve and enhance assigned International Codes or portions thereof. In 2017 the BCAC has held 3 open meetings. In addition, there were numerous Working Group meetings and conference calls for the current code development cycle, which included members of the committee as well as any interested party to discuss and debate the proposed changes. Related documentation and reports are posted on the BCAC website at: <https://www.iccsafe.org/codes-tech-support/codes/codedevelopment-process/building-code-action-committee-bcac>.

Cost Impact

The code change proposal will not increase or decrease the cost of construction .

This proposal is a clarification reminder of the scope of requirements included in the identified sections.

Internal ID: 516

G137-18

IBC: 2703 (New), 2703.1 (New), 2703.2 (New), 2703.3 (New), 2703.4 (New), Chapter 35

Proponent: Jonathan Roberts, UL LLC, representing UL LLC (jonathan.roberts@ul.com)

2018 International Building Code

Add new text as follows:

SECTION 2703 LIGHTNING PROTECTION SYSTEMS

2703.1 General. Where provided, lightning protection systems shall comply with Sections 2703.2 through 2703.4

2703.2 Installation. Lightning protection systems for all new buildings and additions shall be installed in accordance with one of the following methods:

1. NFPA 780.
2. UL 96A.
3. Other approved methods.

UL 96A shall not be utilized for structures used for the production, handling, or storage of ammunition, explosives, flammable liquids or gases, and other explosive ingredients including dust.

2703.3 Additions to existing systems. Where additions are constructed to a building containing a lightning protection system and the existing building's lightning protection system is connected to the new lightning protection system, the entire system shall be inspected and brought into compliance with current standards.

2703.4 Surge protection. Surge protection devices shall be installed for all normal and emergency electrical systems and all communications systems in accordance with Section 2703.2 and NFPA 70.

Add new standard(s) follows:

UL

UL LLC
333 Pfingsten Road
Northbrook IL 60062-2096

96A-2016:

Standard for Installation Requirements for Lightning Protection Systems

NFPA

National Fire Protection Association
1 Batterymarch Park
Quincy MA 02169-7471

780-17:

Standard for the Installation of Lightning Protection Systems

Reason:

Requirements pertaining to Lightning Protection Systems are not currently found within the building code. This code change does not require the installation of lightning protection systems, but simply provides guidance to those that are installing and inspecting lightning protection. NFPA 780 and UL 96A are two standards that are widely used within the industry, but are not very well known to code officials. These standards are in harmony with the provisions of the National Electrical Code, NFPA 70. UL 96A can be used for the installation and inspection of many lightning protection systems but the standard has limitations that are identified in this proposal. This proposal also recognizes the existence of other approved methods currently used, and thus this proposal is not intended to limit these installations. This proposal is intended to provide the code official with help in addressing the installation of these types of systems.

Cost Impact

The code change proposal will not increase or decrease the cost of construction .

The cost will not increase since these requirements are being used today to install and inspect lightning protection systems.

Analysis: A review of the standards proposed for inclusion in the code, NFPA 780-17 and UL 96A-2016, with regard to the ICC criteria for referenced standards (Section 3.6 of CP#28) will be posted on the ICC website on or before April 2, 2018.

Internal ID: 234

G138-18

IBC: 3001.2

Proponent: Andrew Cid, Barrier Free Solutions For The Deaf and Hard of Hearing, representing Barrier Free Solutions For The Deaf and Hard of Hearing

2018 International Building Code

Revise as follows:

3001.2 Emergency elevator communication systems for the deaf, hard of hearing and speech

impaired. An emergency two-way communication system shall be ~~provided~~provided. The system shall provide visible text and audible modes that:

1. ~~Is a visual and text based and a video based 24/7 live interactive system.~~When operating in each mode, includes a live interactive system that allows back and forth conversation between the elevator occupants and emergency personnel;
2. ~~Is fully accessible by the deaf, hard of hearing and speech impaired, and shall include voice only options for hearing individuals. Has the ability to communicate with emergency personnel utilizing existing video conferencing technology, chat/text software or other approved technology.~~operational when the elevator is operational; and
3. Allows elevator occupants to select the text-based or audible mode depending on their communication needs to interact with emergency personnel.

Reason:

This proposal is submitted as there is no new standard published, as of this writing, under the ASME a17 in support of IBC 2018 3001.2. This code proposal also provides additional direction and clarification for industry. Underlined wording is added text to capture the intent of the proposal. This proposal clarifies as to what type of feature and assistance is required and shall be provided regards to the utilization of a text-based system (consisting of keyboard, visual indicators and button indicators) by an entrapped Deaf or Hard of Hearing passenger(s).

I have been working with a dedicated group of industry professionals who have been working hard to develop an a17 standard for 3001.2. My participation in these ASME efforts for the past 3 years have been exciting and productive in attempting to improve the standard to include criteria for these systems. However, the ASME a17 EOC reviews are not yet completed and finalized to my satisfaction to the current code.

It is unfortunate that due to code hearing revision schedules between the ICC and the A17 Emergency Operations Committee where the ICC has a 1/8/18 proposal closing date and the A17 committee may have some possible revisions to 2.27 of A17.1 later this year reflecting provisions addressing two-way communication incorporating video means. It is hopeful that work continues on proposed revisions to 2.27 satisfying the intent of the original provisions of 3001.2. It is recognized that as a general practice that the applicable standard as referenced by the IBC contain the necessary text and provisions and it is the intent that once the A17 committee has developed the necessary language that incorporates the provisions of 3001.2 that this section could be removed. But until such time, recognizing that the A17.1 document revision schedule may not permit inclusion for the 2021 IBC edition, the provisions of 3001.2 need to be maintained.

Unfortunately, I have been the target of recent threats, bullying and intimidation by some individuals who are attempting to discredit me or disrupt our standard language efforts. As a result, I fear for my safety and well being. However, I will continue working to provide assistance to industry, to Fire/Life Safety and First Responders in their jobs in helping others, and to provide access to 50M Deaf & Hard of Hearing citizens.

I hope the IBC committee, industry representatives, and the ICC voters, especially the professional First Responders, agree with this proposal. If approved, this will be effective 2021 and the a17 will hopefully be in place by then to support 3001.2.

Cost Impact

The code change proposal will increase the cost of construction .

The code change proposal may increase the cost of construction by a minimum of less than \$250 (the approximate cost of a keyboard component and several visual indicators)..

Internal ID: 808

G139-18

IBC: 3001.2, DOJ (New)

Proponent: Kevin Brinkman, representing National Elevator Industry, Inc. (klbrinkman@neii.org)

2018 International Building Code

Revise as follows:

3001.2 Emergency elevator communication systems for the deaf, hard of hearing and speech impaired. ~~An emergency two-way communication system shall be provided that:~~

- ~~1. Is a visual and text based and a video based 24/7 live interactive system.~~
- ~~2. Is fully The elevator emergency communication shall provide effective communication as required by Section 36.303 of ADA Title III. The emergency communication shall be installed in accordance with the provisions of ASME A17.1/CSA B44 and NFPA 72 and shall be accessible by the deaf, hard of hearing and speech impaired, and shall include voice-only options for hearing individuals.~~
- ~~3. Has the ability to communicate with emergency personnel utilizing existing video conferencing technology, chat/text software or other approved technology available twenty-four hours a day, seven days a week, as a live interactive system.~~

Add new standard(s) follows:

DOJ United States Department of Justice Civil Rights Division

ADA Title III Regulations - Americans with Disabilities Act, Public Accommodations and Commercial Facilities

Reason:

Section 3001 defines the scope and reference standards for elevator Emergency Communication design requirements. This proposal removes an elevator design requirements from the building code, restoring it to the reference standards. The added reference to the ADA Title III is the regulation specifically for effective communication with the deaf, hard of hearing and speech impaired.

Cost Impact

The code change proposal will not increase or decrease the cost of construction .

The proposal will neither increase or decrease the cost of construction because it is simply restoring the technical requirements to the reference standards as opposed to including them in the IBC.

Analysis:

A review of DOJ ADA Title III Regulations, as proposed for inclusion in the code, with regard to the ICC criteria for referenced standards (Section 3.6 of CP#28) will be posted on the ICC website on or before April 2, 2018.

ASME A17.1/CSA B44 and NFPA 72, as referenced in this proposal, are currently referenced in the code.

Internal ID: 1274

G140-18

IBC: 3002.3, 3002.3.1 (New)

Proponent: Ed Kullik, Chair, representing ICC Building Code Action Committee (bcac@iccsafe.org)

2018 International Building Code

Revise as follows:

3002.3 Emergency signs for other than occupant evacuation elevators... Where other than occupant evacuation elevators are provided, an *approved* pictorial sign of a standardized design shall be posted adjacent to each elevator call station on all floors instructing occupants to use the ~~exit stairways~~ exits and not to use the elevators in case of fire. The sign shall read: IN CASE OF FIRE, ELEVATORS ARE OUT OF SERVICE. USE EXIT STAIRS.

~~Exceptions~~ **Exception:**

- ~~1.~~ The emergency sign shall not be required for elevators that are part of an accessible *means of egress* complying with Section 1009.4.
- ~~2.~~ The emergency sign shall not be required for elevators that are used for occupant self-evacuation in accordance with Section 3008.

Add new text as follows:

3002.3.1 Emergency signs for occupant evacuation elevators. Where occupant evacuation elevators are provided, an approved pictorial sign of a standardized design shall be posted adjacent to each elevator call station on all floors instructing occupants to use occupant evacuation elevators in the event of fire. The sign shall read: IN CASE OF FIRE, THIS OCCUPANT EVACUATION ELEVATOR IS AVAILABLE FOR EXITING THE BUILDING.

Analysis: Duplicated text in the International Fire Code not shown for brevity.

Reason:

This is one of 17 proposals being submitted as a package relating to technical and organizational changes proposed for Chapter 6 of the Fire Code. While the Code Committees will consider each proposal independently, the intent is for approval of all proposals in this package which have been submitted as a correlated set of companion code change proposals.

This proposal correlates with the series of proposals to the IFC Chapter 6 submitted by the F-CAC for correlation of Elevator requirements and specification of required signage for all elevators.

This proposal addresses the emergency signage for the elevators in the IBC and the IFC. The changes are reflected in the IBC as these are the parent sections for these requirements. If approved this language will be duplicated in Chapter 6 of the IFC. This also correlates with the signage requirements in ASME A17.1. Exit stairways were changed to "exits" because there could be ramps instead of stairways.

Two distinct sections are established between occupant evacuation elevators and other than those elevators.

This proposal also adds standardized language to both the IBC and the IFC for occupant evacuation elevator signage to ensure consistency between codes and to provide clear and concise building occupant instruction for their use.

This proposal is submitted by the ICC Building Code Action Committee (BCAC) in support of the FCAC's efforts. BCAC was established by the ICC Board of Directors in July 2011 to pursue opportunities to improve and enhance assigned International Codes or portions thereof. In 2017 the BCAC has held 3 open meetings. In addition, there were numerous Working Group meetings and conference calls for the current code development cycle, which included members of the committee as well as any interested party to discuss and debate the proposed changes. Related documentation and reports are posted on the BCAC website at: <https://www.iccsafe.org/codes-tech-support/codes/code-development-process/building-code-action-committee-bcac>.

Cost Impact

The code change proposal will decrease the cost of construction.

By providing standardized language for the emergency signs for occupant evacuation elevators, and correlating for consistency the standardized language for other elevators.

Internal ID: 407

G141-18

IBC: 3003.1 (New)

Proponent: Keith Flanders, Cosentini Associates, representing self (kflanders@cosentini.com)

2018 International Building Code

Add new text as follows:

3003.1 Elevator Power. Upon loss of power, elevators shall be relocated to the lobby or the nearest floor level and the hoistway doors shall be opened.

Reason:

The applicable codes for elevators and vertical lifts do not currently require a means to lower to the nearest floor or lobby upon loss of power. Where the elevators are not provided with standby power, this leads to occupants becoming entrapped and require assistance from a responding fire department. There is often confusion as to whether this is required, and many may think it is common sense. However, there is nothing in the codes that explicitly requires such an action upon loss of power. Accordingly, this code change proposal includes the specific language to avoid any further confusion and to limit the possibility of occupants becoming entrapped.

Cost Impact

The code change proposal will increase the cost of construction .

This may have a slight impact on the cost of construction; however, it is often included regardless and therefore may not have an impact.

Internal ID: 1019

G142-18

IBC: 3007.1

Proponent: Kevin Brinkman, representing National Elevator Industry, Inc. (klbrinkman@neii.org)

2018 International Building Code

3007.1 General. Where required by Section 403.6.1, every floor above and including the lowest level of fire department vehicle access of the building shall be served by fire service access elevators complying with Sections 3007.1 through 3007.9. Except as modified in this section, fire service access elevators shall be installed in accordance with this chapter and ASME A17.1/CSA B44.

~~Exception~~ Exceptions:

1. Elevators that only service an open or enclosed parking garage and the lobby of the building shall not be required to serve as fire service access elevators.
2. The elevator shall not be required to serve the top floor of a building where that floor is utilized only for equipment for building systems.

Reason:

To align with Section 403.6.1 which addresses occupied floors.

Cost Impact

The code change proposal will decrease the cost of construction .

This would decrease the cost of construction because it would not require an extension on top of the roof of the building so that the elevator could serve an unoccupied floor.

Internal ID: 1449

G143-18

IBC: 3005.4

Proponent: Kevin Brinkman, representing National Elevator Industry, Inc. (klbrinkman@neii.org)

2018 International Building Code

3005.4 Machine rooms, control rooms, machinery spaces, and control spaces. ~~Elevator machine rooms, control rooms, control spaces and machinery spaces outside of but attached to a hoistway that have openings into the hoistway.~~ The following rooms and spaces shall be enclosed with fire barriers constructed in accordance with Section 707 or horizontal assemblies constructed in accordance with Section 711, or ~~both~~ both:

1. Machine rooms
2. Control rooms
3. Control spaces
4. Machinery spaces outside of the hoistway enclosure

The *fire-resistance rating* shall be not less than the required rating of the hoistway enclosure served by the machinery. Openings in the *fire barriers* shall be protected with assemblies having a fire protection rating not less than that required for the hoistway enclosure doors.

Exceptions:

1. For other than fire service access elevators and occupant evacuation elevators, where machine rooms, machinery spaces, control rooms and control spaces do not abut and do not have openings to the hoistway enclosure they serve, the *fire barriers* constructed in accordance with Section 707 or horizontal assemblies constructed in accordance with Section 711, or both, shall be permitted to be reduced to a 1-hour *fire-resistance rating*.
2. For other than fire service access elevators and occupant evacuation elevators, in buildings four *stories* or less above *grade plane* where machine room, machinery spaces, control rooms and control spaces do not abut and do not have openings to the hoistway enclosure they serve, the machine room, machinery spaces, control rooms and control spaces are not required to be fire-resistance rated.

Reason:

There was some confusion with the current wording that the phrase " outside of but attached to a hoistway that have openings into the hoistway" as to how it relates to machine rooms. Essentially this could be possibly interpreted that if no openings to the hoistway exist that a fire resistance rated enclosure would not be required. Control rooms and control spaces should be treated no differently for separation requirements so the added phrase is not necessary. This section is essentially an extension of the hoistway protection.

Cost Impact

The code change proposal will not increase or decrease the cost of construction .

There is no impact since this is just a clarification of the language.

Internal ID: 1451

G144-18

IBC: 3007.3

Proponent: John Mengedoht, representing NBBJ (jmengedoht@nbbj.com)

2018 International Building Code

Revise as follows:

3007.3 Water protection. Water from the operation of an automatic sprinkler system outside the enclosed lobby shall be prevented from infiltrating into the hoistway enclosure by means of a curb and elevator entrance floor levels not less than 1 inch (25.4 mm) above floor areas outside of the lobby area or in accordance with ~~an~~ other approved method-methods.

Reason:

2018 IBC Section 3007.3 does not establish any criteria for an approved method of preventing water from entering the hoistway for fire service access elevators. Establishing a 1 inch height as a minimum for a curb at the hoistway and for the floor at the elevator entrances provides criteria for one approach without the need for floor drains or trench drains, which are an infection risk in high rise hospitals and generally not preferred in high rise office buildings. The 1 inch height is more than necessary to prevent water intrusion into a hoistway but allows for buildings where floors may not be particularly level and might slope downward toward the building core.

Cost Impact

The code change proposal will not increase or decrease the cost of construction .

Establishing one reasonable method of compliance does not rule out other approved solutions and does not increase cost unless a lower height than 1 inch has been widely accepted by code officials previously.

Internal ID: 2290

G145-18

IBC: 3007.8.1, 3008.8.2

Proponent: Lee Kranz, City of Bellevue, WA, representing Washington Association of Building Officials Technical Code Development Committee (lkranz@bellevuewa.gov)

2018 International Building Code

Revise as follows:

3007.8.1 Protection of ~~wiring or cables~~ equipment, control wiring, power wiring and ductwork.

Equipment control wiring, power wiring and ductwork shall be independent of other building ventilation or pressurization systems and shall be protected in accordance with Section 909.20.6.1.

~~Wires or cables that are located outside of the elevator hoistway and machine room and that provide normal or standby power, control signals, communication with the car, lighting, heating, air conditioning, ventilation and fire-detecting systems to fire service access elevators shall be protected using one of the following methods:~~

- ~~1. Cables used for survivability of required critical circuits shall be listed in accordance with UL 2196 and shall have a *fire-resistance rating* of not less than 2 hours.~~
- ~~2. Electrical circuit protective systems shall have a *fire-resistance rating* of not less than 2 hours. Electrical circuit protective systems shall be installed in accordance with their listing requirements.~~
- ~~3. Construction having a *fire-resistance rating* of not less than 2 hours.~~

Exception: Wiring and cables to control signals are not required to be protected provided that wiring and cables do not serve Phase II emergency in-car operations.

3008.8.2 Protection of ~~wiring or cables~~ equipment, control wiring, power wiring and ductwork.

Equipment, control wiring, power wiring and ductwork shall be independent of other building ventilation or pressurization systems and shall be protected in accordance with Section 909.20.6.1.

~~Wires or cables that are located outside of the elevator hoistway, machine room, control room and control space and that provide normal or standby power, control signals, communication with the car, lighting, heating, air conditioning, ventilation and fire-detecting systems to occupant evacuation elevators shall be protected using one of the following methods:~~

- ~~1. Cables used for survivability of required critical circuits shall be listed in accordance with UL 2196 and shall have a *fire-resistance rating* of not less than 2 hours.~~
- ~~2. Electrical circuit protective systems shall have a *fire-resistance rating* of not less than 2 hours. Electrical circuit protective systems shall be installed in accordance with their listing requirements.~~
- ~~3. Construction having a *fire-resistance rating* of not less than 2 hours.~~

Exception: Wiring and cables to control signals are not required to be protected provided that wiring and cables do not serve Phase II emergency in-car operation.

Reason:

The scope of this proposal adds "equipment" and "ductwork" to the list of items needing fire-resistance rated protection for Fire Service Access Elevators and Occupant Evacuation Elevators. It replaces the current text with a reference to Section 909.20.6.1. These established protection measures for pressurized stair enclosures will create a consistent approach for pressurized hoistways. This proposal references Section 909.20.6.1 which includes not only the wiring but also the equipment and ductwork associated the pressurization of the shaft and are critical components of this life-safety system. The exception related to protection of wiring and cables for control signals is maintained in both subsections.

Cost Impact

The code change proposal will increase the cost of construction .

There will be additional cost associated with protection of the pressurization fan and ductwork which are not currently required in the code.

Internal ID: 89

G146-18

IBC: 3102.3, 3102.6.1.1

Proponent: Stephen DiGiovanni, representing ICC Ad Hoc Committee on Tall Wood Buildings (TWB) (TWB@iccsafe.org)

2018 International Building Code

Revise as follows:

3102.3 Type of construction. Noncombustible membrane structures shall be classified as Type IIB construction. Noncombustible frame or cable-supported structures covered by an *approved* membrane in accordance with Section 3102.3.1 shall be classified as Type IIB construction. Heavy timber frame-supported structures covered by an *approved* membrane in accordance with Section 3102.3.1 shall be classified as Type IV-HT construction. Other membrane structures shall be classified as Type V construction.

Exception: Plastic less than 30 feet (9144 mm) above any floor used in greenhouses, where occupancy by the general public is not authorized, and for aquaculture pond covers is not required to meet the fire propagation performance criteria of Test Method 1 or Test Method 2, as appropriate, of NFPA 701.

3102.6.1.1 Membrane. A membrane meeting the fire propagation performance criteria of Test Method 1 or Test Method 2, as appropriate, of NFPA 701 shall be permitted to be used as the roof or as a skylight on buildings of Type IIB, III, IV-HT and V construction, provided that the membrane is not less than 20 feet (6096 mm) above any floor, balcony or gallery.

Reason:

The Ad Hoc Committee on Tall Wood Buildings (TWB) was created by the ICC Board to explore the science of tall wood buildings and take action on developing code changes for tall wood buildings. The TWB has created several code change proposals with respect to the concept of tall buildings of mass timber and the background information is at the end of this Statement. Within the statement are important links to information, including documents and videos, used in the deliberations which resulted in these proposals.

This code change will result in consistency with the purpose and scope which was to leave intact the current Type IV heavy timber provisions. The HT category was created to differentiate the three (3) new categories of “mass timber”, where HT represents the long established heavy timber category that has been in the ICC family of codes, and the predecessor legacy codes, for decades.

Background information: The ICC Board approved the establishment of an ad hoc committee for tall wood buildings in December of 2015. The purpose of the ad hoc committee is to explore the science of tall wood buildings and to investigate the feasibility and take action on developing code changes for tall wood buildings. The committee is comprised of a balance of stakeholders with additional opportunities for interested parties to participate in the four Work Groups established by the ad hoc committee, namely: Code; Fire; Standards/Definitions; and Structural. For more information, be sure to visit the ICC website <https://www.iccsafe.org/codes-tech-support/cs/icc-ad-hoc-committee-on-tall-wood-buildings/> (link active and up to date as of 12/27/17). As seen in the “Meeting Minutes and Documents” and “Resource Documents” sections of the committee web page, the ad hoc committee reviewed a substantial amount of information in order to provide technical justification for code proposals.

The ad hoc committee developed proposals for the followings code sections. The committee believes this package of code changes will result in regulations that adequately address the fire and life safety issues of tall mass timber buildings.

IBC Code Section	Description
403.3.2	Water supply requirements for fire pumps in high rise buildings of Type IVA and IVB construction.
504.3	Allowable building height (feet) for buildings of Type IVA, IVB and IVC construction. No changes to Type IV HT construction.
504.4	Allowable building height (stories) for buildings of Type IVA, IVB and IVC construction. No changes to Type IV HT.
506.2	Allowable building area for buildings of Type IVA, IVB and IVC construction. No changes to Type IV HT.
508.4.4.1 509.4.1.1 (new)	Requirements for mass timber building elements serving as fire barriers or horizontal assemblies in buildings of Type IVB or IVC construction.
602.4	Type of Construction requirements for new proposed types of construction: Types IVA, IVB and IVC. No changes to Type IV HT construction. Includes definitions for new terms: Mass timber and Noncombustible protection (mass timber). THIS IS THE KEY CODE CHANGE PROPOSAL WHICH OUTLINES THE CONSTRUCTION REQUIREMENTS FOR THE PROPOSED NEW TYPE OF MASS TIMBER BUILDINGS. THE PROPOSAL ALSO ADDRESSES CONCEALED SPACES, ADHESIVE PERFORMANCE AND EXTERIOR WALL PROTECTION.
703.8 (new)	The performance method to determine the increase to the fire resistance rating provided by noncombustible protection applied to the mass timber building element.
703.9 (new)	Requirements for sealants and adhesives to be placed at abutting edges and intersections of mass timber building elements. The reason statement references a Group B proposal to Chapter 17 for special inspection requirements of sealants and adhesives.
718.2.1	Requirements on the use of mass timber building elements used for Fireblocking.
722.7 (new)	Requirements for the fire resistance rating of mass timber elements, including minimum required protection and gypsum board attachment requirements.
3102	Requirements for membrane structures using Type IV HT construction.
Appendix	Requirements for walls, floors and roofs of Type IV HT construction in buildings located in Fire Districts.
IFC Code Section	Description
701.6	Requirements which stipulate the owner's responsibility to maintain inventory of all required fire resistance rated construction in buildings of Types IVA and IVB construction. This includes an annual inspection and proper repair where necessary.
3308.4 (new)	New special precautions during construction of buildings of Types IVA, IVB and IVC construction: Standpipes; Water supply for fire department connections; Noncombustible protection required for mass timber elements as construction height increases.
Proposed changes to be submitted in 2019 Group B	
IBC Chapter 17	Required special inspections of mass timber construction <ul style="list-style-type: none"> • Structural • Sealants and adhesives (see IBC 703.8)
IBC Chapter 23	An update to referenced standard APA PRG 320 Standard for Performance –rated Cross-laminated Timber which is currently undergoing revision to ensure the adequacy of the adhesives under fire conditions.

In addition, fire tests designed to simulate the three new construction types (Types IVA, IVB and IVC) in the ad hoc committee proposals were conducted at the Alcohol Tobacco and Firearms test lab facility. The TWB was involved in the design of the tests, and many members witnessed the test in person or online. The results of the series of 5 fire tests provide additional support for these proposals, and validate the fire performance for each of the types of construction proposed by the committee. The fire tests consisted of one-bedroom apartments on two levels, with both apartments having a corridor leading to a stair. The purpose of the tests was to address the contribution of mass timber to a fire, the performance of connections, the performance of through-penetration fire stops, and to evaluate conditions for responding fire personnel.

To review a summary of the fire tests, please visit <http://bit.ly/ATF-firetestreport>

To watch summary videos of the fire tests, please visit <http://bit.ly/ATF-firetestvideos>

Both of these links were confirmed active on 12/27/17.

Cost Impact

The code change proposal will not increase or decrease the cost of construction .

This section provides information that was not previously set forth in the code, and does not change the requirements of current code, thus there is no cost impact when compared with present requirements.

Internal ID: 949

G147-18

IBC: SECTION 202, 202 (New), 3103.1

Proponent: Richard Nix, representing Entertainment Services & Technology Association/Event Safety Alliance (rnix@zoomtown.com)

2018 International Building Code

SECTION 202 DEFINITIONS

Add new definition as follows:

SPECIAL EVENT STRUCTURE. Any ground-supported structure, platform, stage, stage scaffolding or rigging, canopy, tower or similar structure supporting entertainment-related equipment or signage.

Revise as follows:

3103.1 General. The provisions of Sections 3103.1 through 3103.4 shall apply to structures erected for a period of less than 180 days. ~~Tents~~Special event structures, tents, umbrella structures and other membrane structures erected for a period of less than 180 days shall also comply with the International Fire Code. ~~Those erected for a longer period of time shall comply with applicable sections of this code.~~

Reason:

These structures are covered under the scope of IBC Chapter 31, Special Construction. IBC Section 3103 addresses installations <180 days, which are considered "temporary". Temporary tents, any type of membrane covered structure and special events structures are therefore within the scope of IBC Chapter 31, section 3102 and/or section 3103. All of these structures except special event structures are referred to IFC Chapter 31. The IFC has added new requirements in Chapter 31 for special events structures, therefore special event structures must also be referred from IBC Chapter 31 to IFC Chapter 31.

Building Code Officials and others using the IBC as a primary code reference require the proper guidance and direction to IFC Chapter 31. In the last code change cycle, F308-16 replaced the IFC term temporary stage canopy with the term temporary special events structure. Therefore, Temporary special events structures are now covered under the purview of IFC Chapter 31. Coordination with IBC Chapter 31 was both implied and intended to occur as a result of F308-16, due to the special construction and temporary characteristics of these structures. However, that coordination did not occur. This CCP ensures proper coordination between IFC and IBC as intended in the last code change cycle.

This proposed definition for Special Events Structures in IBC is slightly different than that used in IFC, because the word "temporary" is implied by the corresponding IBC section 3103, where these structures are currently mentioned.

Cost Impact

The code change proposal will not increase or decrease the cost of construction .

The proposed change adds a definition for clarity along with a pointer for code coordination.

Internal ID: 311

G148-18

IBC: 3111.1.1, 3111.2, 3111.3.2, 3111.3.3

Proponent: Joseph Cain, Solar Energy Industries Association (SEIA), representing Solar Energy Industries Association (JoeCainPE@gmail.com)

2018 International Building Code

Revise as follows:

3111.1.1 Wind resistance. Rooftop-mounted photovoltaic ~~panels and modules~~ (PV) panel systems and solar thermal collectors shall be designed in accordance with Section 1609.

3111.2 Solar thermal systems. Solar thermal systems shall be designed and installed in accordance with ~~Section 2606.12~~ this section, the International Plumbing Code, the International Mechanical Code and the International Fire Code. Where light-transmitting plastic covers are used, solar thermal collectors shall be designed in accordance with Section 2606.12.

3111.3.2 Fire classification. Rooftop-mounted photovoltaic (PV) panel systems shall have a fire classification in accordance with Section 1505.9. ~~Building-integrated photovoltaic systems~~ BIPV systems installed as the roof covering shall have a fire classification in accordance with Section 1505.8.

3111.3.3 Building-integrated photovoltaic (BIPV) systems. ~~Building-integrated photovoltaic systems that serve as roof coverings~~ BIPV systems installed as the roof covering shall be designed and installed in accordance with Section ~~1507.18-1507.~~

Reason:

Section 3111.1.1 Wind resistance is modified to use the defined term "photovoltaic (PV) panel systems" including the abbreviation PV, and to clarify it is the system designed in accordance with Section 1609, not just PV panels and modules.

Section 3111.2 Solar thermal systems is modified to consider that not all solar thermal collectors incorporate light transmitting plastics.

Section 3111.3.2 Fire classification is modified to use the defined term "photovoltaic (PV) panel systems, including the abbreviation "PV." It is also modified to clarify that the reference to section 1505.8 applies only to BIPV systems installed as the roof covering.

Section 3111.3.3 Building-integrated photovoltaic (BIPV) systems is modified to include the BIPV abbreviation/acronym. It is also modified to include the language "installed as the roof covering," consistent with Section 1505.8 language. The reference to Chapter 15 is corrected to Section 1507, as requirements for BIPV roof covering products are found throughout Section 1507, not just in 1507.18, which is specific to photovoltaic (BIPV) shingles.

Cost Impact

The code change proposal will not increase or decrease the cost of construction .

Editorial changes only. No changes to technical requirements.

Internal ID: 2003

G149-18

IBC: 3112 (New), 3112.1 (New), 3112.2 (New)

Proponent: Steve Martin, Florida Division of Emergency Management, representing Florida Division of Emergency Management (steve.martin@em.myflorida.com); Douglas Wise, Building Officials Association of Florida, representing Building Officials Association of Florida (douglaswise@att.net)

2018 International Building Code

Add new text as follows:

3112 PUBLIC USE RESTROOM BUILDINGS IN FLOOD HAZARD AREAS

3112.1 General. Public use restroom buildings that contain toilet rooms, bathrooms, showers and changing rooms, and those portions of buildings that contain toilet rooms, bathrooms, showers and changing rooms, and where such buildings and portions of buildings are intended for public use and located on publicly owned lands in flood hazard areas, shall comply with the requirements of this section. Public use restrooms that are not elevated or dry floodproofed in accordance with Section 1612 shall comply with Section 3112.2. Portions of buildings that include uses other than public use toilet rooms, bathrooms, showers and changing rooms shall comply with Section 1612.

3112.2 Flood resistance. Public use restrooms that are located in flood hazard areas shall comply with the requirements of ASCE 24, except for elevation requirements, and shall comply with all of the following criteria:

1. The building footprint is not more than 1,500 square feet.
2. Located, designed and constructed to resist the effects of flood hazards and flood loads to minimize flood damage from a combination of wind and water loads associated with the base flood.
3. Anchored to prevent flotation, collapse or lateral movement resulting from hydrodynamic and hydrostatic loads, including the effects of buoyancy during conditions of the base flood.
4. Constructed of flood damage-resistant materials.
5. Where enclosed by walls, the walls have flood openings.
6. Mechanical and electrical systems are located above the base flood elevation.
7. Plumbing fixtures and plumbing connections are located above the base flood elevation.
8. An emergency plan, approved by the jurisdiction, is submitted to the building official where the building design specifies implementation of protection measures prior to the onset of flooding conditions.

Exceptions:

1. Minimum electric service required to address life safety and electric code requirements is permitted below the base flood elevation.
2. Plumbing fixtures and connections are permitted below the base flood elevation provided the fixtures and connections are designed and installed to minimize or eliminate infiltration of floodwaters into the sanitary sewage system and discharges from sanitary sewage systems into floodwaters.

Reason:

Thousands of communities and state agencies have public open space and parks along rivers and shorelines. Many communities experience economic value from tourism and public access to areas that feature water resources. Under the current requirements of the IBC, restrooms for public use that are located in flood hazard areas must meet the same requirements as residential and commercial buildings. In flood hazard areas other than coastal high hazard areas and Coastal A Zones (i.e., in flood zones identified on Federal Emergency Management Agency Flood Insurance Rate Maps with the letter "A"), restroom buildings must either be elevated or dry floodproofed to or above the elevations required by the IBC/ASCE 24. In coastal high hazard areas (flood Zone V) and Coastal A Zones, restroom buildings must be elevated to or above the elevations required by the IBC/ASCE 24.

In Florida and other coastal states, this has resulted in construction of public use restrooms as high as 6 to 18 feet above grade. This poses many challenges, not the least of which is access. Figures 1, 2, 3 and 4 (below) illustrate

elevated restrooms with long ramps. While ramps can be built to meet ADA requirements, to reach some heights required in some flood hazard areas the ramps may be as long as 300 feet. In coastal high hazard areas, such ramps likely conflict with the NFIP requirements that elevated buildings be “free of obstruction,” and the presence of such ramps would likely interfere with the ability of walls around enclosures to break away under flood conditions. Those same provisions are required by IBC Section 1612, Flood Loads, which references ASCE 24, Flood Resistant Design and Construction.

Long ramps defeat accessibility when the distance of travel still renders restroom facilities inaccessible to many persons with disabilities or limited mobility. Although the IBC (and FEMA) permits elevators to extend below the base flood elevation, installing elevators to provide access to elevated public use restrooms is expensive and creates many maintenance issues, and a high rate of failure to function, especially in beach areas where blowing sand and windborne salt aerosols create corrosive conditions.

This proposal creates a new section in IBC Chapter 31, Special Construction to limit the scope to public use restrooms that include public use toilet rooms, bathrooms, showers and changing rooms and spaces. Portions of such buildings that include other uses would have to fully comply with the elevation and other flood resistant requirements of IBC Section 1612, Flood Loads, which references ASCE 24, Flood Resistant Design and Construction.

In recognition that most public use restrooms are built on public land using public funds, the proposal is to limit the potential financial losses associated with flooded public facilities in two ways: by limiting the footprint to not more than 1,500 square feet and by specifying design requirements that minimize or eliminate physical damage when flooding occurs. Enabling public use restrooms to be designed to withstand the hydrodynamic and hydrostatic loads below the base flood elevation is an appropriate alternative to the extremely high cost for design, construction and maintenance of highly elevated public restrooms and their required access ramps or elevators.

Although the proposed design requirements are intended to preclude significant damage during flood conditions up to and including conditions of the design flood (e.g., the base or 100-year flood), more severe floods can and do occur. Figure 5 (below) illustrates one modest design option that demonstrates the feasibility of the proposal. It shows a small masonry restroom on a beach after Hurricane Irma pushed onshore. The drawings for the building show below-grade piling support and it appears the masonry units were filled. Despite approximately 6-8 feet of flooding (including waves), there is no evidence of structural damage and the non-structural damage appears readily repairable.

The proposal includes requirements for flood resistance similar to those found in IBC Appendix G, Section G1001 for Utility and Miscellaneous Group U and similar to the requirements of ASCE 24-14 for Flood Design Class 1 (which is essentially equivalent to Structure/Risk Category I). Those requirements effectively are the same as the NFIP requirements in 44 Code of Federal Regulations Section 60.3(a)(3)(ii), (iii), and (iv). FEMA deems the flood provisions of the I-Codes, with reference to ASCE 24, to meet or exceed the requirements of the National Flood Insurance Program (NFIP).

The intent is to allow public use restrooms to be at-grade or above-grade but below the base flood (partially elevated), provided they meet the design requirements listed in 3112.2. The proponent acknowledges that, at present, FEMA guidance states that restroom buildings and comfort stations in coastal high hazard areas must be elevated and meet the same design and construction requirements as other buildings. This proposal is intended to meet the intent of all NFIP requirements, except elevation requirements, to minimize flood damage, while acknowledging the special needs and access required or appropriate for public use restrooms. The Florida Floodplain Management Association prepared a white paper on this subject: Policy and Design Options for Public Restrooms in Special Flood Hazard Areas (2014), www.FLfloods.org/ffmawhitepaper.



Figure 1. Florida, flood Zone V. Ramp wraps around entire building. Has composting toilets, battery and solar electric system, emergency plan requires pumping out tank and filling with clean water.



Figure 2. Coastal Mississippi, flood Zone V. This facility cost \$1.1 million.



Figure 3. Florida, Gulf Coast, flood Zone V. Ramp built after original elevator determined to be unsustainable due to significant maintenance problems.



Figure 4. Southwest Florida, flood Zone V. Extensive ramp wraps around three sides.



Figure 5. Florida, after Hurricane Irma, flood Zone V. No evidence of structural damage after estimated 5 ft stillwater plus waves. From upper left: facing beach, side, interior, rear.

Bibliography:

Policy and Design Options for Public Restrooms in Special Flood Hazard Areas, Florida Floodplain Management Associations, 2014. 55 pages. www.FLfloods.org/ffmawhitepaper

Cost Impact

The code change proposal will decrease the cost of construction .

The proposal will lower the initial cost of construction and lower routine and long-term facility maintenance. The cost to construct as specified in this proposal to resist the effects of flood hazards and flood loads may be somewhat higher than a typical non-elevated restroom building that is not designed to resist flood loads and flood damage (not currently allowed). However, the cost for construction under the proposal will be less than the cost to elevate and provide and maintain elevators and extensive ramp systems (current method of compliance).

Internal ID: 1094

G150-18

IBC: 3112.4, 3112.5

Proponent: Mike Fischer, Kellen Company, representing The Plastic Glazing Coalition of the American Chemistry Council (mfischer@kellencompany.com)

2018 International Building Code

3112.4 Glass and glazing. Glass and glazing used in *greenhouses* shall comply with Section 2405.

Revise as follows:

3112.5 Light-transmitting plastics. Light-transmitting ~~plastics shall be permitted in lieu of plain glass~~ plastic used as glazing in greenhouses ~~and~~ shall comply with Section 2405 and Section 2606.

Reason:

The current section 3112.5 for light transmitting plastics in greenhouses reads almost as an exception to Section 3112.4 for glass in greenhouses when in fact they contain separate provisions. This change clarifies that the glazing provisions in Section 2405 apply to light-transmitting plastics used as glazing, and maintains the reference to Section 2606.

Cost Impact

The code change proposal will not increase or decrease the cost of construction .

The proposal is editorial and changes no technical provisions.

Internal ID: 2012

G151-18

IBC: (New), 3101.1, 3114 (New), 3114.1 (New), 3114.2 (New), 3114.3 (New), 3114.4 (New), 3114.5 (New), 3114.6 (New), 3114.7 (New), 3114.8 (New), 3114.8.1 (New), 3114.8.1.1 (New), 3114.8.2 (New), 3114.8.3 (New), 3114.8.4 (New), 3114.8.4.1 (New), 3114.8.4.2 (New), 3114.8.4.3 (New), 3114.8.5 (New), 3114.8.5.1 (New), 3114.8.5.2 (New), 3114.8.5.3 (New), 3114.8.5.3(1) (New), 3114.8.5.3(2) (New), 3114.8.5.3(4) (New), 3114.8.5.3(3) (New), 3114.8.5.3 (New), Chapter 35

Proponent: Ed Kullik, representing ICC Building Code Action Committee (bcac@iccsafe.org)

2018 International Building Code

Add new definition as follows:

INTERMODAL SHIPPING CONTAINER. A six-sided steel unit originally constructed as a general cargo container used for the transport of goods and materials.

Revise as follows:

3101.1 Scope. The provisions of this chapter shall govern special building construction including *membrane structures*, temporary structures, *pedestrian walkways* and tunnels, automatic vehicular gates, awnings and *canopies*, marquees, signs, towers, antennas, relocatable buildings, swimming pool enclosures and safety devices, ~~and solar energy systems.~~ ~~systems~~ and intermodal shipping containers.

Add new text as follows:

SECTION 3114 INTERMODAL SHIPPING CONTAINERS

3114.1 General. The provisions of Section 3114 and other applicable sections of this code, shall apply to intermodal shipping containers that are repurposed for use as buildings or structures or as a part of buildings or structures.

Exceptions:

1. Intermodal shipping containers previously approved as existing relocatable buildings complying with Chapter 14 of the International Existing Building Code.
2. Stationary storage battery arrays located in intermodal shipping containers complying with Chapter 12 of the International Fire Code.
3. Intermodal shipping containers that are listed as equipment complying with the standard for equipment, such as air chillers, engine generators, modular data centers, and other similar equipment.

3114.2 Construction Documents. The construction documents shall contain information to verify the dimensions and establish the physical properties of the steel components, and wood floor components, of the intermodal shipping container in addition to the information required by Sections 107 and 1603.

3114.3 Intermodal shipping container information. Intermodal shipping containers shall bear an existing data plate containing the following information as required by ISO 6346 and verified by an approved agency. A report of the verification process and findings shall be provided to the building owner.

1. Manufacturer's name or identification number
2. Date manufactured.
3. Safety approval number.
4. Identification number.
5. Maximum operating gross mass (kg) (Lbs)
6. Allowable stacking load for 1.8G (kg) (lbs)
7. Transverse racking test force (Newtons)
8. Valid maintenance examination date

Where approved by the building official, the markings and existing data plate are permitted to be removed from the intermodal shipping containers before they are repurposed for use as buildings or structures or as a part of buildings or structures.

3114.4 Protection against decay and termites. Wood structural floors of intermodal shipping containers shall be protected from decay and termites in accordance with the applicable provisions of Section 2304.12.1.1.

3114.5 Under-floor ventilation. The space between the bottom of the floor joists and the earth under any intermodal shipping container, except spaces occupied by basements and cellars, shall be provided with ventilation in accordance with Section 1202.4.

3114.6 Roof assemblies. Intermodal shipping container roof assemblies shall comply with the applicable requirements of Chapter 15.

Exception: Single-unit stand-alone intermodal shipping containers not attached to, or stacked vertically over, other intermodal shipping containers, buildings or structures.

3114.7 Joints and voids. Joints and voids that create concealed spaces between intermodal shipping containers, that are connected or stacked, at fire-resistance-rated walls, floor or floor/ceiling assemblies and roofs or roof/ceiling assemblies shall be protected by an approved fire-resistant joint system in accordance with Section 715.

3114.8 Structural. Intermodal shipping containers which conform to ISO 1496-1 that are repurposed for use as buildings or structures, or as a part of buildings or structures, shall be designed in accordance with Chapter 16 and this section.

3114.8.1 Foundations. Intermodal shipping containers repurposed for use as a permanent building or structure shall be supported on foundations or other supporting structures designed and constructed in accordance with Chapters 16 through 23 of this code.

3114.8.1.1 Anchorage. Intermodal shipping containers shall be anchored to foundations or other supporting structures as necessary to provide a continuous load path for all applicable design and environmental loads in accordance with Chapter 16.

3114.8.2 Welds. All new welds and connections shall be equal to or greater than the original connections.

3114.8.3 Structural design. The structural design for the intermodal shipping containers repurposed for use as a building or structure, or as part of a building or structure, shall comply with Section 3114.8.4 or 3114.8.5.

3114.8.4 Detailed design procedure. A structural analysis meeting the requirements of this section shall be provided to the building official to demonstrate the structural adequacy of the intermodal shipping containers.

Exception: Intermodal shipping containers designed in accordance with Section 3114.8.5.

3114.8.4.1 Material properties. Structural material properties for existing intermodal shipping container steel components shall be established by material testing where the steel grade and composition cannot be identified by the manufacturer's designation as to manufacture and mill test.

3114.8.4.2 Seismic design parameters. The appropriate detailing requirements of ASCE 7; response modification coefficient, R ; overstrength factor, Ω_0 ; deflection amplification factor, C_d ; and limits on structural height, h_n , for the corrugated shear wall is permitted to be developed in accordance with generally accepted procedures where approved by the building official in accordance with Section 104.11.

3114.8.4.3 Allowable shear value. The allowable shear values for the intermodal shipping container corrugated steel sheet panel side walls and end walls shall be demonstrated by testing and analysis accordance with Section 104.11. Where penetrations are made in the side walls or end walls designated as part of the lateral force-resisting system, the penetrations shall be substantiated by rational analysis.

3114.8.5 Simplified structural design of single-unit containers. Single-unit intermodal shipping containers conforming to the limitations of Section 3114.8.5.1 shall be permitted to be designed in accordance with the simplified structural design provisions of Section 3114.8.5.

3114.8.5.1 Limitations. Use of Section 3114.8.5 is subject to all the following limitations:

1. The intermodal shipping container shall be a single-unit, stand-alone unit supported on a foundation and shall not be in contact with or supporting any other shipping container or other structure.
2. The intermodal shipping container top and bottom rails, corner castings, and columns or any portion thereof shall not be notched, cut, or removed in any manner.

3. The intermodal shipping container shall be erected in a level and horizontal position with the floor located at the bottom.
4. The intermodal shipping container shall be located in Seismic Design Category A, B, C or D.

3114.8.5.2 Simplified structural design. Where permitted by Section 3114.8.5.1, single-unit, stand-alone intermodal shipping containers shall be designed using the following assumptions for the corrugated steel shear walls:

1. The appropriate detailing requirements contained in Chapters 16 through 23.
2. Response modification coefficient, $R=2$,
3. Overstrength factor, $\Omega_0=2.5$,
4. Deflection amplification factor, $C_d = 2$, and
5. Limits on structural height, $h_n = 9.5$ feet (2,900 mm).

3114.8.5.3 Allowable shear. The allowable shear for the corrugated steel side walls (longitudinal) and end walls (transverse) for wind design and for seismic design using the coefficients of Section 3114.8.5.2 shall be permitted to have the allowable shear values set forth in Table 3114.8.5.3 provided that all of the following conditions are met:

1. The total linear length of all openings in any individual side walls or end walls shall be limited to not more than 50% of the length of that side walls or end walls, as shown in Figure 3114.8.5.3(1).
2. Any full height wall length, or portion thereof, less than 4 feet (305 mm) long shall not be considered as a portion of the lateral force-resisting system, as shown in Figure 3114.8.5.3(2).
3. All side walls or end walls used as part of the lateral force-resisting system shall have an existing or new boundary element on all sides to form a continuous load path, or paths, with adequate strength and stiffness to transfer all forces from the point of application to the final point of resistance, as shown in Figure 3114.8.5.3(3).
4. Where openings are made in container walls, floors, or roofs for doors, windows and other openings:
 - 4.1 The openings shall be framed with steel elements that are designed in accordance with Chapter 16 and Chapter 22.
 - 4.2. The cross section and material grade of any new steel element shall be equal to or greater than the steel element removed.
5. A maximum of one penetration not greater than a 6-inch (152 mm) diameter hole for conduits, pipes, tubes or vents, or not greater than 16 square inches (10,322 sq mm) for electrical boxes, is permitted for each individual 8 foot length (2,438 mm) lateral force resisting wall. Penetrations located in walls that are not part of the wall lateral force resisting system shall not be limited in size or quantity. Existing intermodal shipping container vents shall not be considered a penetration, as shown in Figure 3114.8.5.3(4).
6. End wall door or doors designated as part of the lateral force-resisting system shall be welded closed.

•

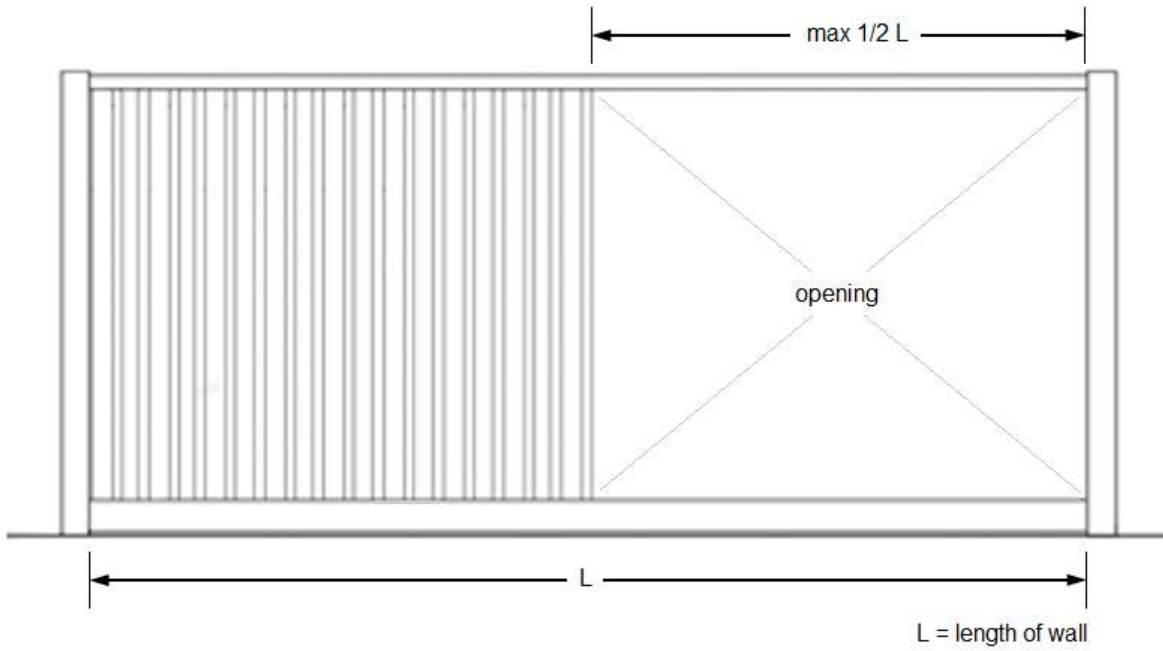

3114.8.5.3(1)
Bracing Unit Distribution--Maximum Linear Length

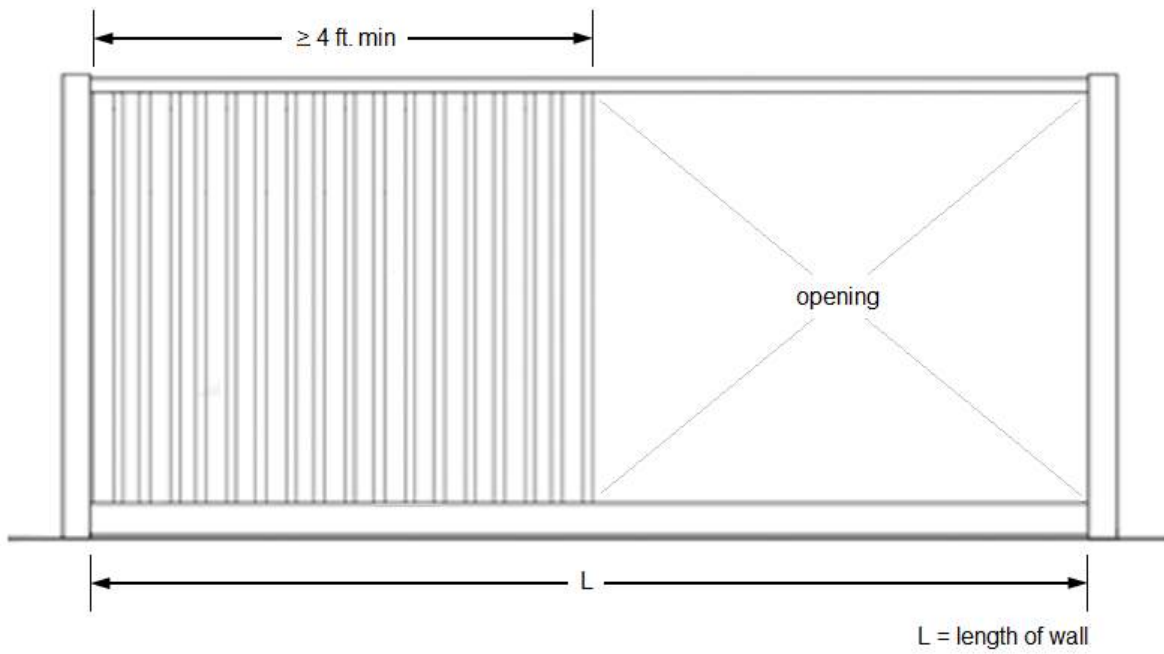

3114.8.5.3(2)
Bracing Unit Distribution -- Minimum Linear Length

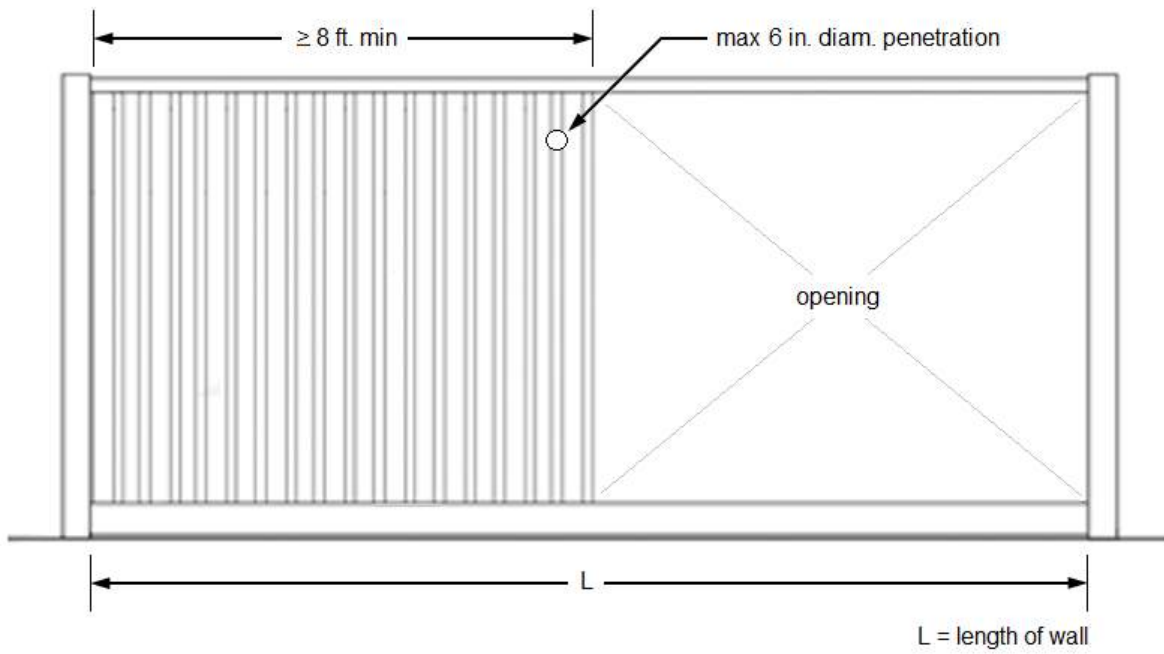

3114.8.5.3(4)
Bracing Unit Distribution -- Penetration Limitations

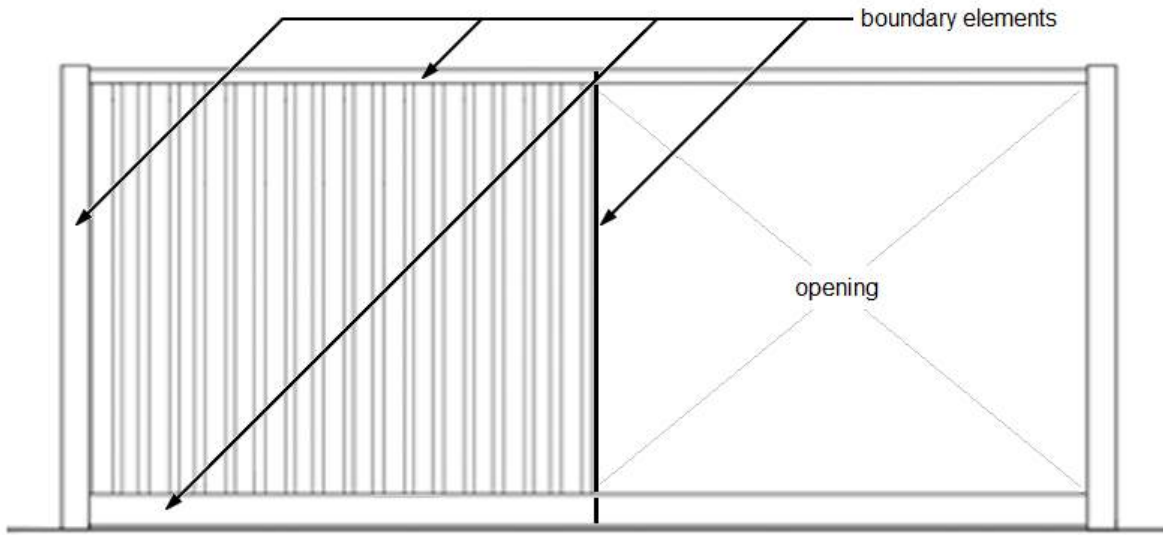

3114.8.5.3(3)
Bracing Unit Distribution -- Boundary Elements

TABLE 3114.8.5.3**Allowable Strength Values for Intermodal Shipping Container Corrugated Steel Siding Shear Walls for Wind or Seismic Loading**

CONTAINER DESIGNATION ²	CONTAINER DIMENSION (Nominal Length)	CONTAINER DIMENSION (Nominal Height)	ALLOWABLE SHEAR VALUES (PLF) ^{1,3}	
			Side Wall	End Wall
1EEE	45 feet (13.7 M)	9.5 feet (2896 mm)	75	843
1EE		8.6 feet (2591 mm)		
1AAA	40 feet (12.2 M)	9.5 feet (2896 mm)	84	
1AA		8.5 feet (2592 mm)		
1A		8.0 feet (2438 mm)		
1AX				
1BBB	30 feet (9.1 M)	9.5 feet (2896 mm)	112	
1BB		8.5 feet (2591 mm)		
1B		8.0 feet (2438 mm)		
1BX				
1CC	20 feet (9.1 M)	8.5 feet (2591 mm)	168	
1C		8.0 feet (2438 mm)		
1CX				
1D	10 feet (3.0 M)	8.0 feet (2438 mm)	337	
1DX				

1. The allowable strength shear for the side walls and end walls of the intermodal shipping containers are derived from ISO 1496-1 and reduced by a factor of safety of 5.
2. Container designation type is derived from ISO 668.
3. Limitations of Sections 3114.8.5.1 shall apply

Add new standard(s) follows:

ISO

International Organization for
Standardization
Chemin de Blandonnet 8 CP 401
1214 Vernier
Geneva Switzerland

ISO 668: 2013:

Series 1 Freight Containers - Classifications, dimensions and ratings

ISO 1496-1: 2013:

Series 1 Freight Containers - Specification and Testing - Part 1: General Cargo Containers for General Purposes

ISO 6346: 1995, with Amendment 3: 2012:

Freight Containers - Coding, Identification and marking

Reason:

This code change purpose is to introduce intermodal shipping containers into the International Building Code based on requests by code officials in the U.S. Prior to this proposal, several jurisdictions had created their own individual regulations or ordinances, or had administered additional requirements beyond the code (e.g. Section 104.11 "Alternative materials, design and methods of construction and equipment") so as to be comfortable to ensure a safe structure. This code change proposal is in response to those requests to develop a set of consistent code provisions which cover the minimum safety requirements, but which do not duplicate existing code provisions.

This proposal covers:

Creation of a new definition in order to separate the container from other I-code sections which refer to, but intentionally do not define, shipping containers,

Creating exceptions so to differentiate the intermodal shipping container from other code sections which could be interpreted as applying to intermodal shipping containers under other applications (e.g. temporary storage, relocatable buildings, energy storage facilities, and listed equipment),

Verification of containers construction, condition, and structural integrity to assist the structural engineer in the evaluation for building construction,

References to other sections concerning foundations, decay and termite control, crawlspace ventilation, roof assemblies, interior finishes, and joints/intersections.

Introduction of structural provisions unique to intermodal shipping containers and which do not duplicate the existing structural requirements, and

Addition of three ISO standards for reference.

Chapter 2 - New definition - A new definition has been created in order that these provisions can be adequately enforced and not confused the other multiple varieties of definitions of containers currently in the market.

Section 3114.1 - This represents the charging statement that outlines the requirements for containers, and list the appropriate exceptions with the I-codes in order to coordinate with other provisions that may appear similar in nature and where intermodal shipping containers could possibly be used in those other applications.

Section 3114.2 - Construction documents - These provision emphasize the material requirements as specified in this section.

Section 3114.3 - Verification - These provisions focus on the characteristics of the intermodal shipping container prior to it being repurposed. In this case the provisions require a straight forward inspection by an approved agency, and verification of the data plate which is normally found on intermodal shipping containers. There was an intent not to specify who the approved agency would be for two reasons; 1) so as to allow the code official or state law(s) to handle this aspect recognizing that in each jurisdiction their requirements may be different, and 2) to avoid dictating an international agreement onto jurisdictions that are currently employed by the shipping and container manufacturers worldwide today. In this case, the standards are regulated by the International Convention of Safe Containers (CSC) that have policies and procedures for inspecting containers worldwide. These procedures include policies for Approved

Continuous Examination Program (ACEP) at the time the container is used in production, and policies for third party inspection agencies. The list shown in this section is a extract from the ISO standard and serves as a reference of items to be verified in order to validate the type of container.

3114.4 through 3114.6 - While we have strived to focus on only those provisions that recognize the unique aspects of intermodal shipping containers, we felt that some direction references were appropriate. In this case specific pointers are provided to foundations, decay and termite control, crawlspace ventilation, and roof requirements addressing drainage and weather protection.

3114.7 - Joints and voids - This provision is provided to address the interstitial spaces that may be created when multiple intermodal shipping containers are connected or stacked, whereby that concealed space between the containers is protected to prevent fire and hot gasses from passing between containers.

Section 3114.8 - Structural - The structural provisions are divided into multiple categories, as follows: 1) the general characteristics for all containers; 2) engineered structural design; and 3) simplified method for single-unit stand-alone container.

3114.8.1 - Foundations or supports - Provisions have been included to outline the two options for securing the container; a foundation or the connection to another structure. This provision makes it clear that the load path anchorage is required for all containers and to ensure the designed performance provided by the remainder of the structural provisions.

3114.8.2 - Welds - An additional provision has been added to require that any new welds be designed and installed with welds of greater structural capabilities.

Section 3114.8.4 - Detailed structural analysis - The detailed analysis engineering approach represents the general engineering practice allowed for all other types of building constructions. For this section the engineer of record is allowed to practice as they normally would for any other building type. As may be noted much of this section requires submission through the alternative means and methods provisions in order to obtain a permit as information about intermodal shipping containers is not readily listed in the IBC provisions or referenced standards.

Section 3114.8.5 - Simplified analysis - The concept for the single container approach is to make the design and construction process simpler. The provisions include a strict listing of limitations for use of these provisions. The proposal also provides structural design information, and pre-established shear wall information that is contained in the ISO 1496-1 standard, which is used to design and construct intermodal shipping containers. The shear wall values were obtained from the ISO 1496-1 standard through engineering analysis using a factor of safety of 5. In addition, a provision was installed to limit the number and size of openings and service holes within the container, as well as to prevent building owners or designers from embellishing the size to something most engineers would define as an opening. This method is intended to address the simple structure approach and provide available information for use by the structural engineer to supplement their work.

Chapter 35 - Referenced Standards - Included with this proposal are three ISO standards which are relevant to the intermodal shipping container's construction. These standards are part of the industry standards regulated by the International Convention of Safe Containers (CSC) that have policies and procedures for inspecting containers worldwide.

BCAC - The International Code Council's Building Code Action Committee (BCAC) was established by the ICC Board of Directors to pursue opportunities to improve and enhance an assigned International Code or portion thereof. This includes both the technical aspects of the codes as well as the code content in terms of scope and application of referenced standards. Since its inception in July, 2011, the BCAC has held open meetings and numerous workgroup calls which included members of the BCAC as well as any interested party to discuss and debate the proposed changes and the public comments. Related documentation and reports are posted on the BCAC website at: <http://www.iccsafe.org/cs/BCAC/Pages/default.aspx>.

The ICC Building Code Action Committee created a task group to facilitate the development of this proposal. Members of the assigned task group included representatives from: City of Long Beach, CA; County of Mecklenburg, NC; Modular Building Institute; American Iron and Steel Institute; Underwriters Laboratories; and the Portland Cement Association. Additional contacts included the State of California (Division of State Architect, Housing and Community Development), City of San Diego; City of Los Angeles, CA; City of Seattle; Clark County, NV; Falcon Structures, RADCO a Twining Company, SEABOX Company, FEMA ATC Seismic Code Support Committee, and other guests who provided their individual expertise.

Cost Impact

The code change proposal will decrease the cost of construction .

The code change proposal will decrease the cost of construction. This new code section will provide clarity on how to consistently design with, permit, and field inspect shipping containers that are repurposed for building construction. Current use of repurposed intermodal shipping containers requires the building owner or designee to submit through

the alternative means and methods administrative provisions.

Analysis: A review of the standards proposed for inclusion in the code, ISO 668, ISO 1496-1 and ISO 6346, with regard to the ICC criteria for referenced standards (Section 3.6 of CP#28) will be posted on the ICC website on or before April 2, 2018.

Internal ID: 1586

G152-18

IBC: D102.2.5

Proponent: Stephen DiGiovanni, representing ICC Ad Hoc Committee on Tall Wood Buildings (TWB) (TWB@iccsafe.org)

2018 International Building Code

Revise as follows:

D102.2.5 Structural fire rating. Walls, floors, roofs and their supporting structural members shall be not less than 1-hour fire-resistance-rated construction.

Exceptions:

1. Buildings of Type IV-HT construction.
2. Buildings equipped throughout with an *automatic sprinkler system* in accordance with Section 903.3.1.1.
3. Automobile parking structures.
4. Buildings surrounded on all sides by a permanently open space of not less than 30 feet (9144 mm).
5. Partitions complying with Section 603.1, Item 11.

Reason:

The Ad Hoc Committee on Tall Wood Buildings (TWB) was created by the ICC Board to explore the science of tall wood buildings and take action on developing code changes for tall wood buildings. The TWB has created several code change proposals with respect to the concept of tall buildings of mass timber and the background information is at the end of this Statement. Within the statement are important links to information, including documents and videos, used in the deliberations which resulted in these proposals.

This code change proposal will result in consistency with the purpose and scope which was to leave intact the current Type IV heavy timber provisions. The HT category was created to differentiate the three (3) new categories of “mass timber”, where HT represents the long established heavy timber category that has been in the ICC family of codes, and the predecessor legacy codes for decades.

Background information: The ICC Board approved the establishment of an ad hoc committee for tall wood buildings in December of 2015. The purpose of the ad hoc committee is to explore the science of tall wood buildings and to investigate the feasibility and take action on developing code changes for tall wood buildings. The committee is comprised of a balance of stakeholders with additional opportunities for interested parties to participate in the four Work Groups established by the ad hoc committee, namely: Code; Fire; Standards/Definitions; and Structural. For more information, be sure to visit the ICC website <https://www.iccsafe.org/codes-tech-support/cs/icc-ad-hoc-committee-on-tall-wood-buildings/> (link active and up to date as of 12/27/17). As seen in the “Meeting Minutes and Documents” and “Resource Documents” sections of the committee web page, the ad hoc committee reviewed a substantial amount of information in order to provide technical justification for code proposals.

The ad hoc committee developed proposals for the followings code sections. The committee believes this package of code changes will result in regulations that adequately address the fire and life safety issues of tall mass timber buildings.

IBC Code Section	Description
403.3.2	Water supply requirements for fire pumps in high rise buildings of Type IVA and IVB construction.
504.3	Allowable building height (feet) for buildings of Type IVA, IVB and IVC construction. No changes to Type IV HT construction.
504.4	Allowable building height (stories) for buildings of Type IVA, IVB and IVC construction. No changes to Type IV HT.
506.2	Allowable building area for buildings of Type IVA, IVB and IVC construction. No changes to Type IV HT.
508.4.4.1 509.4.1.1 (new)	Requirements for mass timber building elements serving as fire barriers or horizontal assemblies in buildings of Type IVB or IVC construction.
602.4	Type of Construction requirements for new proposed types of construction: Types IVA, IVB and IVC. No changes to Type IV HT construction. Includes definitions for new terms: Mass timber and Noncombustible protection (mass timber). THIS IS THE KEY CODE CHANGE PROPOSAL WHICH OUTLINES THE CONSTRUCTION REQUIREMENTS FOR THE PROPOSED NEW TYPE OF MASS TIMBER BUILDINGS. THE PROPOSAL ALSO ADDRESSES CONCEALED SPACES, ADHESIVE PERFORMANCE AND EXTERIOR WALL PROTECTION.
703.8 (new)	The performance method to determine the increase to the fire resistance rating provided by noncombustible protection applied to the mass timber building element.
703.9 (new)	Requirements for sealants and adhesives to be placed at abutting edges and intersections of mass timber building elements. The reason statement references a Group B proposal to Chapter 17 for special inspection requirements of sealants and adhesives.
718.2.1	Requirements on the use of mass timber building elements used for Fireblocking.
722.7 (new)	Requirements for the fire resistance rating of mass timber elements, including minimum required protection and gypsum board attachment requirements.
3102	Requirements for membrane structures using Type IV HT construction.
Appendix	Requirements for walls, floors and roofs of Type IV HT construction in buildings located in Fire Districts.
IFC Code Section	Description
701.6	Requirements which stipulate the owner's responsibility to maintain inventory of all required fire resistance rated construction in buildings of Types IVA and IVB construction. This includes an annual inspection and proper repair where necessary.
3308.4 (new)	New special precautions during construction of buildings of Types IVA, IVB and IVC construction: Standpipes; Water supply for fire department connections; Noncombustible protection required for mass timber elements as construction height increases.
Proposed changes to be submitted in 2019 Group B	
IBC Chapter 17	Required special inspections of mass timber construction <ul style="list-style-type: none"> • Structural • Sealants and adhesives (see IBC 703.8)
IBC Chapter 23	An update to referenced standard APA PRG 320 Standard for Performance –rated Cross-laminated Timber which is currently undergoing revision to ensure the adequacy of the adhesives under fire conditions.

In addition, fire tests designed to simulate the three new construction types (Types IVA, IVB and IVC) in the ad hoc committee proposals were conducted at the Alcohol Tobacco and Firearms test lab facility. The TWB was involved in the design of the tests, and many members witnessed the test in person or online. The results of the series of 5 fire tests provide additional support for these proposals, and validate the fire performance for each of the types of construction proposed by the committee. The fire tests consisted of one-bedroom apartments on two levels, with both apartments having a corridor leading to a stair. The purpose of the tests was to address the contribution of mass timber to a fire, the performance of connections, the performance of through-penetration fire stops, and to evaluate conditions for responding fire personnel.

To review a summary of the fire tests, please visit <http://bit.ly/ATF-firetestreport>

To watch summary videos of the fire tests, please visit <http://bit.ly/ATF-firetestvideos>

Both of these links were confirmed active on 12/27/17.

Cost Impact

The code change proposal will not increase or decrease the cost of construction .

This section provides information that was not previously set forth in the code, and does not change the requirements of current code, thus there is no cost impact when compared with present requirements.

Internal ID: 951

G153-18

IBC: SECTION H102, H102.1, 202, H105.2, H105.3, H105.4, H105.5, H109.2

Proponent: Richard Milne, representing self

2018 International Building Code

SECTION H102 DEFINITIONS

H102.1 General. The following words and terms shall, for the purposes of this appendix, have the meanings shown herein. Refer to Chapter 2 of this code for general definitions.

Delete without substitution:

~~**COMBINATION SIGN.** A sign incorporating any combination of the features of pole, projecting and roof signs.~~

~~**DISPLAY SIGN.** The area made available by the sign structure for the purpose of displaying the advertising message.~~

Revise as follows:

~~**GROUND SIGN, MONUMENT OR ENCLOSED PYLON SIGN, also defined as a ground sign.** A billboard or similar type of sign that is supported by one or more uprights, poles or braces in or upon the ground other than a combination sign or pole sign, as defined by this code.~~ sign that is supported by an internal structure embedded in the ground, but has a full fascia covering or is created to rest entirely upon the ground. Definition to include all pre-fabricated EPS structures and similar prefabricated monument style signs. Ground signs are defined as a fully fabricated sign that extended to the ground. Ground signs can include EPS structures that rest upon the ground but are supported and anchored internally by embedded poles, or signs that are supported by an external structure that is clad or built to be an integral part of the sign design (a rock pillar on either side supporting the sign structure in between, so long as the sign structure touches the ground, as an example). Ground signs shall not exceed 10 feet in overall height. Internal or external supports shall be embedded into the ground to required local code depth.

~~**POLE SIGN-SIGN (Freestanding sign)** A sign wholly supported by a sign structure in the ground. Pole signs shall have visible supports to the main message area. Pole signs shall be no less than 36" from grade to bottom of sign or as local code dictates within sight triangles.~~

~~**ROOF SIGN.** A sign erected on or above a roof or parapet of a building or structure. Roof sign structures are to be supported entirely by an approved structure fastened to the roof deck or surrounding parapet.~~

H105.2 Permits, drawings and specifications. Where a permit is required, as provided in Chapter 1, construction documents shall be required. These documents shall show the dimensions, material and required details of construction, including loads, stresses and anchors.
All signs are required to be permitted where required.

Ground signs 32 square feet and under are not required to provide engineer drawings for load and stresses.

Pole signs 32 square feet and under and less than 12 feet to the top of the sign are not required to provide engineer drawings for load and stresses.

H105.3 Wind load. Signs shall be designed and constructed to withstand wind pressure as provided for in Chapter ~~16.16.~~

Ground signs 32 square feet and under and fully supported by an internal structure and resting on the ground are exempt from this section.

Pole signs 32 square feet and under and 12 feet or less to the top of the sign are exempt from this section.

Delete without substitution:

~~**H105.4 Seismic load.** Signs designed to withstand wind pressures shall be considered capable of withstanding earthquake loads, except as provided for in Chapter 16.16.~~

Revise as follows:

H105.5 Working stresses. In outdoor advertising display signs (billboards, freestanding signs or projecting signs over 32 square feet and above 20 feet from grade), the allowable working stresses shall conform to the requirements

of Chapter ~~16-16~~. The working stresses of wire rope and its fastenings shall not exceed 25 percent of the ultimate strength of the rope or fasteners.

Exceptions:

1. The allowable working stresses for steel and wood shall be in accordance with the provisions of Chapters 22 and ~~23-23~~.
2. The working strength of chains, cables, guys or steel rods shall not exceed one-fifth of the ultimate strength of such chains, cables, guys or steel.

H109.2 Required clearance. The bottom coping of every ~~ground~~ freestanding sign shall be not less than 3 feet (914 mm) above the ground or street level, ~~which space can be filled with platform decorative trim or light wooden construction or as defined by local codes within a working sight triangle.~~

Reason:

Inaccurate or overlapping definitions.



Pylon,
Freestanding,
Pole



Ground,
Monument



Cost Impact

The code change proposal will decrease the cost of construction .

For small sign shops (5 employees and under or under \$100K gross annual revenue) the current codes as defined require substantial investments with outside engineering firms for engineered drawings for signage that should not

require such drawings. As the current code stands, for example, I would need an engineered drawing for wind load, stresses and concrete psi ratings for something as small as 4 square feet on a single pole 6 feet from grade.

Internal ID: 137

G154-18

IBC: APPENDIX P (New), SECTION P101 (New), P101.1 (New), SECTION P102 (New), P102.1 (New), SECTION P103 (New), P103.1 (New), TABLE P103.1(1) (New), TABLE P103.1(2) (New), SECTION P104 (New), P104.1 (New), TABLE P104.1(1) (New), SECTION P105 (New), P105.1 (New), P105.1.1 (New), SECTION P106 (New), P106.1 (New), P106.1.1 (New), SECTION P107 (New), P107.1 (New), SECTION P108 (New), P108.1 (New), UL (New), CDPH (New)

Proponent: Ed Kullik (bcac@iccsafe.org)

2018 International Building Code

Add new text as follows:

APPENDIX P MATERIAL EMISSIONS

SECTION P101 GENERAL

P101.1 Scope. Site applied or installed adhesives and sealants, architectural coatings, floor, ceiling and wall assemblies and systems and insulation that are located on the interior side of the building envelope shall comply with Sections P102 through P107. Emission testing shall be performed by an ISO/IEC 17025 accredited laboratory that has the CDPH/EHLB/Standard Method v1.2, USEPA Method TO-17 and ASTM Standard Method D5197 within the scope of its accreditation. Approved agencies that are deeming products compliant with the product emission requirements shall be accredited to ISO/IEC 17065 and have the relevant certification program in the scope of their accreditation.

SECTION P102 DEFINITIONS

P102.1 General. The following words and terms shall, for the purposes of this appendix, have the following meanings shown herein.

VOLATILE ORGANIC COMPOUND (VOC). A chemical compound based on carbon chains or rings that typically contain hydrogen and sometimes contain oxygen, nitrogen and other elements, and that has a boiling point in the range from (50°C to 100°C) to (240°C to 260°C).

SECTION P103 ADHESIVES AND SEALANTS

P103.1 General. Not less than 85 percent by weight or volume, of site-applied adhesives and sealants shall comply with the VOC content limits specified in Table P103.1(1) or the VOC emissions limits specified in Table P103.1(2). The VOC content adhesives, sealants and sealant primers shall be determined and limited in accordance with SCAQMD Rule 1168. HVAC duct sealants shall be classified as "Other" category within the SCAQMD Rule 1168 sealants table. The provisions of this section shall not apply to adhesives and sealants subject to state or federal consumer product VOC regulations. HVAC duct sealants shall be classified as "Other" category within the SCAQMD Rule 1168 sealants table.

Compliance with Table P103.1(2) shall be determined utilizing test methodology incorporated by reference in the CDPH/EHLB/Standard Method v1.2 and shall comply with the limit requirements for either office or classroom spaces, regardless of the space type.

Exceptions: The following solvent welding and sealant products are not required to comply with the emissions or the VOC content requirements of this section

1. Cleaners, solvent cements and primers used with plastic piping and conduit in plumbing, fire suppression and electrical systems.
2. HVAC air duct sealants where the air temperature of the space in which they are applied is less than 40°F (4.5°C).

TABLE P103.1(1)
SITE APPLIED ADHESIVE AND SEALANT VOC LIMITS ^{a, b}

Adhesive	VOC Limit g/l
Indoor carpet adhesives	50
Carpet Pad adhesives	50
Outdoor carpet adhesives	150
Wood flooring adhesive	100
Rubber floor adhesive	60
Subfloor adhesives	50
Ceramic tile adhesives	65
VCT and asphalt tile adhesives	50
Dry wall and panel adhesives	50
cove base adhesives	50
Multipurpose construction adhesives	70
Structural glazing adhesives	100
Single ply roof membrane adhesives	250
Architectural sealants	250
Architectural Sealant Primer	
Non-porous	250
Porous	775
Modified bituminous sealant primer	500
Other sealant primers	750
CPVC solvent cement	490
PVC solvent cement	510
ABS solvent cement	325
Plastic cement welding	250
Adhesive primer for plastic	550
Contact Adhesive	80

<u>Special Purpose Contact Adhesive</u>	<u>250</u>
<u>Structural wood member adhesive</u>	<u>140</u>

a. VOC limit less water and less exempt compounds in grams/liter (g/l)

b. For low-solid adhesives and sealants, the VOC limit is expressed in grams/liter of material as specified in SCAQMD Rule 1168. For all other adhesives and sealants, the VOC limits are expressed as grams of VOC per liter of adhesive or sealant less water and less exempt compounds as specified in Rule 1168.

TABLE P103.1(2)
VOC EMISSION LIMITS

VOC	LIMIT
Individual VOC's	<1/2 CA chronic REL ^a
Formaldehyde	< 9 µg/m ³ or < 7 ppb

a. CDPH/EHLB/Standard Method v1.2 Chronic Reference Exposure Level (CREL).

SECTION P104 ARCHITECTURAL COATINGS

P104.1 General. Not less than 85 percent of the weight or volume of site-applied architectural coatings specified in this section shall comply with either VOC content limits established in Table P104.1(1) or the VOC emissions limits in Table P103.1(2)

1. Anticorrosive coatings.
2. Basement specialty coatings.
3. Concrete/masonry sealers.
4. Concrete curing compounds.
5. Dry fog coatings.
6. Faux finish coatings.
7. Fire-resistive coatings.
8. Flat and non-flat topcoats.
9. Floor coatings.
10. Graphic arts (sign) coatings.
11. High-temperature coatings.
12. Industrial maintenance coatings.
13. Low solids coatings
14. Mastic texture coatings
15. Metallic pigmented coatings.
16. Multicolor coatings.
17. Pretreatment wash primers.
18. Primers
19. Reactive penetrating sealers.
20. Recycled coatings.
21. Shellacs, clear and opaque.
22. Specialty primers.
23. Stains
24. Stone consolidants.
25. Swimming pool coatings.
26. Tub- and tile-refining coatings.
27. Under coaters.
28. Waterproofing membranes.
29. Wood coatings including clear wood finishes.
30. Wood preservatives.
31. Zinc primers.

Compliance with Table P103.1(2) shall be determined utilizing test methodology incorporated by reference in the CDPH/EHLB/Standard Method v1.2 and shall comply with the limit requirements for either office or classroom spaces of the space type.

TABLE P104.1(1)
VOC CONTENT LIMITS FOR ARCHITECTURAL COATINGS ^{a,b}

Coating Category	Limit ^c g/l
Flat coatings	50
Non-flat coatings	100-
Non-flat high gloss coatings	250
Aluminum roof coatings	400
Basement specialty coatings	400
Bituminous roof coatings	50
Bituminous roof primers	350
Bond breakers	350
Concrete curing compounds	350
Concrete/masonry sealers	100
Driveway sealers	50
Dry fog coatings	150
Faux finishing coatings	350
Fire resistive coatings	350
Floor coatings	100
Form-release compounds	250
Graphic arts (sign) coatings	500
High temperature coatings	420
Industrial maintenance coatings	250
Low solids coatings	120 ^d
Magnesite cement coatings	450
Mastic texture coatings	100
Metallic pigmented coatings	500
Multi-color coatings	250
Pre-treatment wash primers	420
Primers, sealers and undercoaters	100
Reactive penetrating sealers	350
Recycled coatings	250
Roof coatings	50
Rust Preventative Coatings	250
Shellacs, clear	730
Shellacs, opaque	550
Specialty primers and sealers	100
Stains	250
Stone Consolidants	450
Swimming pool coatings	340
Traffic marking coatings	100
Tub and tile refinish coatings	420
Waterproof membranes	250
Wood coatings	275
Wood preservatives	350
Zinc-rich primers	340

- a. The specified limits remain in effect unless revised limits are provided in subsequent columns of the table.
- b. Table P104.1(1) architectural coating regulatory category and VOC content compliance determination shall conform to the California Air Resources Board Suggested Control Measure for Architectural Coatings.
- c. Limits are expressed as VOC Regulatory (except as noted) thinned to the manufacturer's maximum thinning recommendation, excluding any colorant added to tint bases.
- d. Limit is expressed as VOC actual.

SECTION P105 FLOORING

P105.1 General. A minimum of 85 percent of the total area of flooring installed within the interior of the building shall comply with the VOC limits in Table P103.1(2). Where flooring with more than one distinct product layer is installed, the emissions from each layer shall comply with these requirements. Compliance with Table P103.1(2) shall be determined utilizing test methodology incorporated by reference in the CDPH/EHLB/Standard Method v1.2 and shall comply with the limit requirements for either office or classroom spaces regardless of the space type.

P105.1.1 Deemed to comply. Floor covering materials that are composed of the following materials shall be deemed to comply with the VOC emission limits in Table P103.1(2). Where these products include integral organic-based surface coatings, binders or sealants or are installed using adhesives, sealants, paints or coatings, those products shall be subject to other requirements of this appendix.

1. Ceramic and concrete tile.
2. Natural stone.
3. Gypsum plaster.
4. Concrete masonry.
5. Clay masonry.
6. Metal.

SECTION P106 CEILING AND WALL ASSEMBLIES AND SYSTEMS

P106.1 General. A minimum of 85 percent of the total area of ceiling and wall assemblies and systems installed shall comply with VOC limits in Table P103.1(2). Where assemblies and systems have more than one distinct product layer are installed, the emissions from each layer shall comply with these requirements. Compliance with Table P103.1(2) shall be determined utilizing test methodology incorporated by reference in the CDPH/EHLB/Standard Method v1.2 and shall comply with the limit requirements for either office or classroom spaces regardless of the space type.

P106.1.1 Deemed to comply. Ceiling and wall assembly and system materials that are composed of the following materials shall be deemed to comply with the VOC limits in Table P103.1(2). Where these products include integral organic-based surface coatings, binders or sealants or are installed using adhesives, sealants, paints or coatings, those products shall be subject to other requirements of this appendix.

1. Ceramic and concrete tile.
2. Natural stone.
3. Gypsum plaster.
4. Concrete masonry.
5. Clay masonry.
6. Metal.

SECTION P107 INSULATION

P107.1 General. Not less than 85 percent of insulation, by square feet, installed shall comply with the VOC limits in Table P103.1(2). Compliance with Table P103.1(2) shall be determined utilizing test methodology incorporated by reference in the CDPH/EHLB/Standard Method v1.2 and shall comply with the limit requirements for either office or classroom spaces regardless of the space type.

Add new standard(s) follows:

SECTION P108 REFERENCED STANDARDS CDPH

California Department of Public Health, 850 Marina Bay Parkway, Richmond, CA 94804

CDPH/EHLB/Standard Method v1.2' Standard Method for the Testing and Evaluation of Volatile Organic Chemical Emissions from Indoor Sources Using Environmental Chambers Version 1.2"; January 2017, California Department of Public Health.

ISO

International Organization for Standardization, Chemin de Blandonnet 8, CP401, 1214 Vernier, Geneva, Switzerland

ISO/IEC 17025-05 General Requirements for the Competence of Testing and Calibration Laboratories.

ISO/IEC 17065-12 Requirements for bodies certifying products, processes and services.

EPA

U.S. Environmental Protection Agency, Stationary Source Compliance Divisions, Washington D.C.

US EPA Method TO-17 (issued 1/1999) Determination of Volatile Organic Compounds in Ambient Air Using Active Sampling on to Sorbent Tubes.

ASTM

ASTM D5197-16 Standard Method for Determination of Formaldehyde and Other Carbonyl Compounds in Air (Active Sampler Methodology)

SCAQMD

South Coast Air Quality Management District, 21865 Copley Drr. Diamond Bar, CA 91765

Rule 1168-1989 Adhesive and Sealant Applications, with amendments through January 7, 2005.

CEPA

California Environmental Protection Agency, Air Resources Board, 1001 I Street, Sacramento, CA 95814

Suggested Control Measures for Architectural Coatings, February 1, 2008.

P108.1 General.

UL Underwriters Laboratories 36y8082130231- the standard title

CDPH California Department of Public Health, 850 Marina Bay Parkway, Richmond, CA 94804
CDPH California Department of Public Health, 850 Marina Bay Parkway, Richmond, CA 94804

CDPH/EHLB/Standard Method v1.2' Standard Method for the Testing and Evaluation of Volatile Organic Chemical Emissions from Indoor Sources Using Environmental Chambers Version 1.2"; January 2017, California Department of Public Health.

Reason:

In the last couple of decades our building codes have pushed for tighter building envelopes, more efficient and mechanical ventilation, with the goal of conserving energy and preserving water tightness. But this changes the indoor environment to a potentially adverse environment for occupants. Good indoor air quality (IAQ) is predicated on three factors, correct ventilation, correct filtration, and source control. As our codes have evolved we've done well to focus on the first two (correct ventilation and filtration), but have not sufficiently addressed source control. Various materials we regularly use in the construction and fit out of our buildings have emissions of volatile organic compounds (VOC). Limiting the emissions to an acceptable level has been established as the method for source control.

The material emission requirements detailed in this proposal are based on commonly found VOC in our indoor environment that can come off of products. The California Office of Environmental Health Hazard Assessment (CA OEHHA) and California Department of Public Health (CDPH) developed the list of 35 individual VOC that are in each requirement. Numerous studies from around the globe show that exposure to high levels of some of the commonly found VOC detailed in these requirements can cause not only severe discomfort, but headaches, nose bleeds, increased asthma attacks, the onset of asthma, and potential long-term health effects. Some of these studies even show that continued exposure to some of these VOC can lead to an increase in C-reactive protein levels in human subjects, which is the body's response to inflammation.

Section 101.3 of the IBC, states, "The purpose of this code is to establish the minimum requirements to provide a reasonable level of safety, public health and general welfare...". With the potential issues indoor occupants can receive due to poor indoor air quality, the intent of the IBC implores us to put source control in to protect public health and general welfare. Chapter 12 of the IBC governs the Interior Environment and has provisions for ventilation and

surrounding materials associated with the interior spaces of buildings.

Many different stakeholder groups, including but not limited to, researchers, health officials, manufacturers, laboratories, and governmental representatives, have been involved in the development of the referenced test methods, many of the studies, and in the codification of these requirements previously. North American and many global manufacturers have embraced the lowering of emissions in the name of source control and there are thousands of product that have proven to satisfy the proposed criteria in this section, at competitive prices, which ensures there is enough supply to satisfy the demand. With these thousands of products available the cost of development and purchase has steadily come down to levels that are on par with other products. Code officials, designers, installers, and building owners have many free resources to find compliant products and manufacturers even have ways to prove compliance to these requirements on their own.

Builders will be able to show compliance in much the same way as they show compliance to many other fire, electrical, and other safety requirements in the codes. As with those other requirements, there are numerous laboratories around the globe that meet the qualifications to perform the tests required in this proposal. Numerous ISO 17065 accredited third-parties around the globe also supply certifications that prove compliance to these requirements as well, so code officials have approved agencies that they already use and trust to help them prove compliance to these parameters.

These requirements have been in the International Green Construction Code (IgCC) and ASHRAE 189.1 since their inception and hundreds of authorities having jurisdictions already have these requirements in place, from large cities such as Washington DC, Dallas, TX, or Baltimore, MD to smaller jurisdictions such as Merced, CA, Scottsdale, AZ, Carbondale, CO, North Bend, WA, and Boynton Beach, FL. Products are available throughout the nation and builders are aware of how to find these products and show compliance to these requirements. As these types of requirements have been in green building codes and ratings systems for over a decade most North American manufacturers have many if not all of their products compliant with the requirements detailed above.

The 85% level detailed in the requirements was originally put in to the other code documents in recognition of the nature of construction. Some of the products in the requirements are products that are common from project to project and sometimes construction teams will utilize a little of the left over product from previous projects to complete a new project. While this is not ideal for the potential emissions emitted into the indoor environment, the overall impact of having to rip out all of the potentially impacted products for the small potential amount of emissions from the up to 15% of non-compliance products.

Some of the products detailed below are deemed not to need permits in the IBC and therefore may not be seen by the code official, but IBC 105.2 states, "Exemptions from permit requirements of this code shall not be deemed to grant authorization for any work to be done in any manner in violation of the provisions of this code or any other laws or ordinances of this jurisdiction." If there is a potential issue for indoor occupants the code should still cover it even if an AHJ decides that it doesn't want to require documentation to detail compliance as the Intent detailed in Section 101.3 of the IBC brings us back to ensure health and general welfare. Including these minimum material emission restrictions in the IBC will ensure that all building occupants, not just those fortunate enough to be in a 'sustainable' building will be protected from harmful chemicals and pollutants.

The proposal adds new reference standard to Chapter 35 which have been previously referenced in the International Green Construction Code and they have been proven to be appropriate and acceptable for making the evaluations of VOC content and emissions that are detailed in the proposal.

In closing, the reasons for these requirements are:

As our building and energy codes require tighter and tighter buildings with less and less air changes, we need to ensure that all three pillars of good indoor air quality are addressed in codes.

Almost all North American manufacturers have products that already show compliance to these requirements, but some of our most recent issues have come with some products brought in from overseas.

Providing a reasonable level of safety, public health and general welfare is the stated purpose of this code. With the availability of products, ease of compliance review, and potential improvements in the indoor environment, these requirements fit the purpose of the IBC without extraordinary burden to any of the levels of building.

This proposal is submitted by the ICC Building Code Action Committee (BCAC). The proposal was brought to the BCAC by the ICC Sustainability, Energy, High Performance Code Action Committee (SEHPCAC). Both CACs were established by the ICC Board of Directors in July 2011 to pursue opportunities to improve and enhance assigned International Codes or portions thereof. In 2017 the BCAC and SEHPCAC have each held 3 open meetings. In addition, there were numerous Working Group meetings and conference calls for the current code development cycle, which included members of the committee as well as any interested party to discuss and debate the proposed changes. Related documentation and reports are posted on the BCAC website at: <https://www.iccsafe.org/codes-tech-support/codes/code-development-process/building-code-action-committee-bcac>.

Bibliography:

Studies or Statements:

http://oem.bmj.com/content/52/6/388.abstract?ijkey=a259a5df5523262ebc77dbf9c265a51aa6d71686&keytype2=tf_ipsecsha
http://erj.ersjournals.com/content/20/2/403.abstract?ijkey=0fa737bd14c56216d6cda0c24409c8f3b4686dc7&keytype2=tf_ipsecsha
<http://www.bioportfolio.com/resources/pmarticle/76147/Volatile-Organic-Compounds-Exposure-And-Cardiovascular-Effects-In-Hair-Salons.html>
<http://onlinelibrary.wiley.com/doi/10.1111/j.1600-0668.2010.00673.x/abstract>
<https://www.epa.gov/indoor-air-quality-iaq/volatile-organic-compounds-impact-indoor-air-quality>
<http://www.health.state.mn.us/divs/eh/indoorair/voc/>
<https://www.healthlinkbc.ca/healthlinkbc-files/air-quality-VOCs>
<https://www.cdph.ca.gov/Programs/CCDPHP/DEODC/OHB/WRAPP/CDPH%20Document%20Library/full-disclosure-required-a-strategy-to-prevent-asthma-through-building-product-selection.pdf#search=%E2%80%9CStandard%20Method%20for%20the%20Testing%20and%20Evaluation%20of%20Vo>
Standards

California Department of Public Health

850 Marina Bay Parkway

Richmond, CA 94804

CDPH/EHLB/Standard Method V1.2 “Standard Method for the Testing and Evaluation of Volatile Organic Chemical Emissions from Indoor Sources Using Environmental Chambers Version 1.2” dated January 2017, California Department of Public Health

(http://berkeleyanalytical.com/sites/default/files/CDPH-IAQ_StandardMethod_V1_2_2017.pdf)

ISO

ISO/IEC 17025-2005 General Requirements for the Competence of Testing and Calibration Laboratories...(<https://www.iso.org/standard/39883.html>)

ISO/IEC 17065:2012 Requirements for bodies certifying products, processes and services
(<https://www.iso.org/standard/46568.html>)

U. S. Environmental Protection Agency

Stationary Source Compliance Division

Washington, D.C.

US EPA Method TO-17 (issued 1/1999) Determination of Volatile Organic Compounds in Ambient Air Using Active Sampling Onto Sorbent Tubes (<https://www3.epa.gov/ttnamti1/files/ambient/airtox/to-17r.pdf>)

ASTM

ASTM D5197-16 - Standard Method for Determination of Formaldehyde and Other Carbonyl Compounds in Air (Active Sampler Methodology) (<https://www.astm.org/Standards/D5197.htm>)

South Coast Air Quality Management District

21865 Copley Dr

Diamond Bar, CA 91765

Rule 1168-1989 Adhesive and Sealant Applications, with amendments through January 7, 2005.....
(<http://www.aqmd.gov/docs/default-source/rule-book/reg-xi/rule-1168.pdf>)

California Environmental Protection Agency

Air Resources Board

1001 I Street

Sacramento, CA 95814

California Air Resources Board Suggested Control Measure for Architectural Coatings, February 1, 2008
(https://www.arb.ca.gov/coatings/arch/Approved_2007_SCM.pdf)

Cost Impact

The code change proposal will not increase or decrease the cost of construction .

No impact should happen as these requirements have been in building codes and rating systems for over a decade. Due to this most manufacturers have products that meet these requirements already. In fact numerous manufacturers don't make a product that doesn't meet these requirements.

Analysis: A review of the new standards proposed for inclusion in the code, ISO/IEC 17065-12 and USEPA Method TO-17, with regard to the ICC criteria for referenced standards (Section 3.6 of CP#28) will be posted on the ICC website on or before April 2, 2018.

The other standards referenced in the changes by this proposal, ISO/IEC 17025, CDPH/EHLB Standard Method v1.2, ASTM D5197, SCAQMD Rule 1168 and CEPA Suggested Control Measures for Architectural Coatings, are currently referenced in other I-Codes.

Internal ID: 1062

IBC Structural Code Change Proposals

The following code change proposals are labeled as structural code change proposals because they are proposals for changes to sections in chapters of the International Building Code that are designated as the responsibility of the IBC-Structural Code Development Committee (see page ix of the Introductory pages of this monograph), which meets in the Group B cycle in 2019. However the changes included in this Group A code development cycle are to sections of the code that have been prefaced with a [BF] or [BG], meaning that they are the responsibility of a different IBC Code Development Committee—either the IBC-Fire Safety Committee [BF] or the IBC-General Committee [BG].

The committee assigned for each code change proposal is indicated in a banner statement near the beginning of the proposal. Both the IBC-Fire Safety and the IBC-General hearing orders are include here for your reference.

2018 GROUP A – PROPOSED CHANGES TO THE INTERNATIONAL BUILDING CODE – FIRE SAFETY

FIRE SAFETY CODE COMMITTEE

Kenneth E. Bush, Chair

Rep: National Association of State Fire Marshals
Chief Fire Protection Engineer
Maryland State Fire Marshal's Office
Easton, MD

Joseph McElvaney, Jr., PE, Vice Chair

Lead Fire Protection Engineer
City of Phoenix Fire Department
Phoenix, AZ

Nelson Bryner

Chief, Fire Research Division
National Institute of Standards and Technology
Gaithersburg, MD

Matthew Dobson

Rep: National Association of Home Builders
Vice President, Regulatory and Advocacy
Vinyl Siding Institute
Burlington, NC

Kevin Duerr-Clark, PE

Assistant Director for Technical Support,
Professional Engineer II
NY Department of State, Division of Building
Standards and Codes
Albany, NY

Kara Gerczynski

Rep: Fire Marshal's Association of Colorado
Fire Marshal
Elizabeth Fire Protection District
Kiowa, CO

Robert M. Longo, AIA

Rep: AIA New Jersey
Partner
Cornerstone Architectural Group LLC
South Plainfield, NJ

John Mengedoht, AIA

Senior Associate
NBBJ
Seattle, WA

Bob D. Morgan, PE, CPCU

Senior Fire Protection Engineer
Fort Worth Fire Department
Fort Worth, TX

Dennis Richardson, PE, CBO

Western Regional Manager
American Wood Council
Santa Rosa, CA

Richard A. Soltis, Jr.

Fire SubCode Official
Lawrence Township
Lawrence, NJ

John Swanson

Deputy State Fire Marshal-Inspector/Plans
Examiner
Minnesota State Fire Marshal Division
Lakeville, MN

Michael Tomaselli, PE, M. Eng

Fire Protection Engineer
Anne Arundel County
Annapolis, MD

Richard N. Walke

Senior Regulatory Engineer
Underwriters Laboratories
Northbrook, IL

Mang sum Mercy Wong, RA

Code Development Architect-Technical Affairs
and Code Development
New York Department of Buildings
New York, NY

Staff Secretariat

Kermit Robinson

Senior Technical Staff
International Code Council
Western Regional Office
Brea, CA

Michelle Britt, LEED AP

Director, Energy Programs
Technical Services
International Code Council
Central Regional Office
Country Club Hills, IL

2018 GROUP A – PROPOSED CHANGES TO THE INTERNATIONAL BUILDING CODE – GENERAL

GENERAL CODE COMMITTEE

Gary Lewis, Chair
Chief Inspector
City of Summit
Summitt, NJ

Steven L. McDaniel, CPCA, Vice Chair
Building Official
City of Corning
Corning, NY

Matt Belcher
Rep: National Association of Home Builders
Principal
Verdatek Solutions LLC
Wildwood, MO

Brian Bishop, CBO
Deputy Building Official
City of Des Moines
Des Moines, IA

Amy T. Carpenter, AIA
Senior Designer/Project Manager-Vice President
SFCS Architects
Blue Bell, PA

John Catlett, MCP
Director of Codes & Standards
BOMA International
Washington, DC

Jenifer Gilliland, MPA
Code Development Analyst
City of Seattle
Seattle, WA

Raymond A. Grill, PE, LEED AP
Principal
Arup
Washington, DC

Ron E. Hampton, MCP, CBO
Field Inspector II
KY Department of Housing, Building & Const.
Div. Building Code Enforcement
Catlettsburg, KY

Eirene Knott, MCP, CBO, CFM
Director of Code Services
BRR Architecture
Merriam, KS

Thomas Pitchford, CBO
Chief Building Official
Greenwood, Village, CO

Michael Pokorny, PE
Firefighter/Rescuer III
Montgomery County Fire & Rescue Service
Aspen Hill, MD

Michael Shannon, PE, CBO
Development Services Director-Building Official
City of San Antonio, Development Services
Department
San Antonio, TX

Steven R. Winkel, FAIA, PE, CASp
Rep: The American Institute of Architects
Partner, West Coast Office Manager
The Preview Group, Inc.
Berkeley, CA

James M. Williams, AIA, PE, CE, SE, LEED AP
President
AE URBIA
South Jordan, UT

Staff Secretariat

Kermit Robinson
Senior Technical Staff
International Code Council
Western Regional Office
Brea, CA

Allan Bilka, RA
Senior Staff Architect
International Code Council
Central Regional Office
Country Club Hills, IL

TENTATIVE ORDER OF DISCUSSION 2018 PROPOSED CHANGES TO THE INTERNATIONAL PROPERTY MAINTENANCE CODE

The following is the tentative order in which the proposed changes to the code will be discussed at the public hearings. Proposed changes which impact the same subject have been grouped to permit consideration in consecutive changes.

Proposed change numbers that are indented are those which are being heard out of numerical order. Indentation does not necessarily indicate that one change is related to another. Proposed changes may be grouped for purposes of discussion at the hearing at the discretion of the chair. Note that some FS code change proposals may not be included on this list, as they are being heard by another committee.

F4-18, Part II	FS38-18	FS75-18	FS112-18
G7-18	FS39-18	FS76-18	FS113-18
G12-18	FS40-18	FS77-18	FS114-18
FS1-18	FS41-18	FS78-18	FS115-18
FS2-18	FS42-18	FS79-18	FS116-18
FS3-18	FS43-18	FS80-18	G6-18
FS4-18	FS44-18	F92-18 Part II	FS117-18
FS7-18	FS45-18	FS82-18	FS118-18
FS8-18	FS46-18	FS83-18	FS119-18
FS9-18	FS47-18	FS84-18	FS120-18
FS10-18	FS48-18	FS85-18	FS121-18
FS11-18	FS49-18	FS86-18	FS122-18
FS12-18	FS50-18	FS87-18	FS123-18
FS13-18	FS51-18	FS88-18	FS124-18
FS14-18	FS52-18	FS89-18	FS125-18
FS15-18	FS53-18	FS90-18	FS126-18
FS16-18	FS54-18	E97-18	FS127-18
FS17-18	FS55-18	FS91-18	FS128-18
FS18-18	FS56-18	FS92-18	FS129-18
FS19-18	FS57-18	FS93-18	FS130-18
FS20-18	FS58-18	FS94-18	FS131-18
FS21-18	FS59-18	FS95-18	FS132-18
FS22-18	FS60-18	FS96-18	FS133-18
FS23-18	FS61-18	FS97-18	FS134-18
FS24-18	G34-18	FS98-18	FS135-18
FS25-18	FS62-18	FS99-18	FS136-18
FS26-18	FS63-18	FS100-18	FS137-18
FS27-18	FS64-18	FS101-18	FS138-18
FS28-18	FS65-18	FS102-18	FS139-18
FS29-18	FS66-18	FS103-18	FS140-18
FS30-18	FS67-18	FS104-18	FS141-18
FS31-18	FS68-18	FS105-18	FS142-18
FS32-18	FS69-18	FS106-18	FS143-18
FS33-18	FS70-18	FS107-18	FS144-18
FS34-18	FS71-18	FS108-18	FS145-18
FS35-18	M72-18	FS109-18	FS146-18
FS36-18	FS72-18	FS110-18	FS147-18
FS37-18	FS74-18	FS111-18	FS148-18

FS149-18
FS150-18
FS151-181
 S2-18
 S3-18
 S4-18
FS152-18
 S5-18
 S6-18
 S7-18
 S8-18
 S9-18
FS153-18
 G3-18
 S6-18
FS154-18
 S14-18
 S15-18
 S16-18
 S17-18
 S18-18
 S19-18
 S20-18
 S21-18
 G10-18
 G11-18
FS155-18
FS156-18
FS157-18
FS158-18
FS159-18
FS160-18
FS161-18

TENTATIVE ORDER OF DISCUSSION 2018 PROPOSED CHANGES TO THE INTERNATIONAL BUILDING CODE – GENERAL

The following is the tentative order in which the proposed changes to the code will be discussed at the public hearings. Proposed changes which impact the same subject have been grouped to permit consideration in consecutive changes.

Proposed change numbers that are indented are those which are being heard out of numerical order. Indentation does not necessarily indicate that one change is related to another. Proposed changes may be grouped for purposes of discussion at the hearing at the discretion of the chair. Note that some G code change proposals may not be included on this list, as they are being heard by another committee.

G9-18	G64-18	G80-18	S12-18
G13-18	G65-18	G84-18	S13-18
G14-18	G66-18	G89-18	G137-18
G15-18 Part I	G68-18	FS5-18	G138-18
G8-18	G71-18 Part I	FS6-18	G139-18
G16-18	G72-18	FS73-18	G140-18
G17-18	G73-18	FS81-18	G141-18
G18-18	G74-18	G146-18	G143-18
G21-18	G76-18	G152-18	G142-18
G22-18	G77-18	G109-18	G144-18
G23-18 Part I	G78-18	G110-18	G145-18
G24-18	G79-18	G111-18	G147-18
G25-18	G81-18	G112-18	G148-18
G1-18	G82-18	G113-18	G149-18
G2-18	G83-18	G114-18	G150-18
G30-18	G85-18	G115-18	G151-18
G32-18	G86-18	G116-18 Part I	F262-18 Part II
G33-18	G87-18	G117-18	F267-18 Part II
G36-18	G88-18	G118-18	G153-18
G37-18	G90-18	G119-18	G154-18
G39-18	G93-18	G120-18	
G40-18	G94-18	M15-18 Part II	
G41-18	G95-18	G121-18	
G42-18	G96-18	G122-18	
G46-18	G97-18	G123-18	
G47-18	G98-18	G124-18	
G48-18	G99-18	G125-18	
G53-18	G100-18	G126-18	
G54-18	G101-18	G127-18	
G55-18	G102-18	G128-18	
G56-18	G103-18	G129-18	
G57-18	G104-18	G130-18 Part I	
G58-18	G105-18	G131-18	
G59-18	G106-18	G133-18	
G60-18	G107-18	G135-18	
G61-18	G108-18	G136-18	
G62-18	G27-18	S10-18	
G63-18	G75-18	S11-18	

S1-18

IBC: [P]1502.1, [P]1502.2

Proponent: Jason Wilen AIA CDT RRO, National Roofing Contractors Association (NRCA), representing National Roofing Contractors Association (NRCA) (jwilen@nrca.net)

THIS PROPOSAL WILL BE HEARD BY THE INTERNATIONAL PLUMBING CODE COMMITTEE. SEE THE IPC-IPSDC HEARING AGENDA.

2018 International Building Code

Revise as follows:

[P] 1502.1 General. Design and installation of roof drainage systems shall comply with this Section and Section 1611 of this code ~~and Sections 1106 and 1108, as applicable, and Chapter 11~~ of the International Plumbing Code.

[P] 1502.2 Secondary (emergency overflow) drains or scuppers. Where roof drains are required, secondary (emergency overflow) roof drains or scuppers shall be provided where the roof perimeter construction extends above the roof in such a manner that water will be entrapped if the primary drains allow buildup for any reason. The installation and sizing of secondary emergency overflow drains, leaders and conductors shall comply with ~~Sections 1106 and 1108, as applicable, Section 1611 of this code and Chapter 11~~ of the International Plumbing Code.

Reason:

The proposed change provides a pointer to IBC Section 1611—Rain Loads. This pointer makes sure a designer considers the structural-related requirements for roof drainage system design that are currently in the structural section of the code. Additionally, we proposed to modify the references to sections in the International Plumbing Code. Currently, only Section 1106—Size of Conductors, Leaders and Storms Drains and Section 1108—Secondary (Emergency) Roof Drains are referenced where other sections in Chapter 11 may be relevant for a particular project. This problem is remedied by referencing IPC Chapter 11 as opposed to specific subsections.

Cost Impact

The code change proposal will not increase or decrease the cost of construction .

The proposed change does not increase the stringency of the code.

Internal ID: 1215

S2-18

IBC: 1505.2

Proponent: Jason Wilen AIA CDT RRO, National Roofing Contractors Association (NRCA), representing National Roofing Contractors Association (NRCA) (jwilen@nrca.net)

THIS PROPOSAL WILL BE HEARD BY THE IBC FIRE SAFETY CODE COMMITTEE. SEE THE IBC-FS HEARING AGENDA.

2018 International Building Code

[BF] 1505.2 Class A roof assemblies. Class A roof assemblies are those that are effective against severe fire test exposure. Class A roof assemblies and roof coverings shall be *listed* and identified as Class A by an *approved* testing agency. Class A roof assemblies shall be permitted for use in buildings or structures of all types of construction.

Exceptions:

1. Class A roof assemblies include those with coverings of brick, masonry or an exposed concrete roof deck.
2. Class A roof assemblies also include ferrous or copper shingles or sheets, metal sheets and shingles, clay or concrete roof tile or slate installed on noncombustible decks or ferrous, copper or metal sheets installed without a roof deck on noncombustible framing.
3. Class A roof assemblies include minimum 16 ounce per square foot (0.0416 kg/m²) copper sheets installed over combustible decks.
4. Class A roof assemblies include slate installed over ASTM ~~D226~~-D4869, Type ~~II~~ underlayment over combustible decks.

Reason:

Currently a ASTM D226, Type II underlayment is listed as an underlayment for slate as part of exception 4 but its use as an underlayment is not included in the scope of ASTM D226. An identical underlayment for slate roofing listed in Table 1507.1.1(1) underlayment Types is ASTM D4869, Type IV. ASTM D4869's scope includes the use of the material as an underlayment, so we propose changing the reference in exception 4 to ASTM D4869, Type IV as referenced in Table 1507.1.1(1). It is our intent to submit a code change in Group B to remove the reference to ASTM D226, Type II from Table 1507.1.1(1).

Cost Impact

The code change proposal will not increase or decrease the cost of construction .

Adding an equivalent option for an underlayment already listed in the code does not change the stringency of the existing exception.

Staff Analysis: The referenced standard in this proposal, ASTM D4869, is currently referenced in the I-Codes.

Internal ID: 1197

S3-18

IBC: 1505.8, 1505.9

Proponent: Joseph Cain, Solar Energy Industries Association (SEIA), representing Solar Energy Industries Association (JoeCainPE@gmail.com)

THIS PROPOSAL WILL BE HEARD BY THE IBC FIRE SAFETY CODE COMMITTEE. SEE THE IBC-FS HEARING AGENDA.

2018 International Building Code

Revise as follows:

[BF] 1505.8 Building-integrated photovoltaic (BIPV) products. *Building-integrated photovoltaic-BIPV products* installed as the roof covering shall be tested, *listed* and *labeled* for fire classification in accordance with Section 1505.1.

[BF] 1505.9 Rooftop-mounted photovoltaic (PV) panel systems. Rooftop ~~rack-mounted~~ *photovoltaic (PV) panel systems* shall be tested, *listed* and identified with a fire classification in accordance with UL 1703 and UL 2703. The fire classification shall comply with Table 1505.1 based on the type of construction of the building.

Reason:

This proposal includes editorial changes only, and does not change technical requirements.

The definition of Building-Integrated Photovoltaic (BIPV) Products in Chapter 2 already includes the shortened acronym BIPV. As BIPV products become more popular, the code can be made easier to read by moving toward use of the abbreviation/acronym "BIPV" instead of the 11-syllable long term. By using the full term and abbreviation/acronym in the title of Section 1505.8 (as in the Chapter 2 definition), the reader will understand the meaning of BIPV.

Similarly, the abbreviation "PV" entered the 2018 IFC in Section 1204.1. Even though the abbreviation "PV" is not yet included in IBC Chapter 2 definitions, language can be clear if both "photovoltaic" and "PV" terms are used. The definitions themselves cannot be revised until Group B, as they are preceded by [BS]. This usage will set up the code for a transition to greater use of the abbreviation.

In Section 1505.9, the language "Rooftop rack-mounted" is revised to "Rooftop-mounted" because there are an increasing number of rooftop mounted systems that are "rail-less" or "rail-free." These systems use the module frame as the bending member, and do not appear to be installed on a "rack." This proposed language improves Section 1505.9 by using language consistent with other sections of these codes, and consistent with a growing number of mounting systems in the marketplace.

Cost Impact

The code change proposal will not increase or decrease the cost of construction .

The proposal includes editorial changes only, and does not change technical requirements.

Internal ID: 1996

S4-18

IBC: 1505.9

Proponent: Jason Wilen AIA CDT RRO, National Roofing Contractors Association (NRCA), representing National Roofing Contractors Association (NRCA) (jwilen@nrca.net)

THIS PROPOSAL WILL BE HEARD BY THE IBC FIRE SAFETY CODE COMMITTEE. SEE THE IBC-FS HEARING AGENDA.

2018 International Building Code

Revise as follows:

[BF] 1505.9 Rooftop mounted photovoltaic panel systems. Rooftop rack-mounted *photovoltaic panel systems* shall be tested, *listed* and identified with a fire classification in accordance with UL 1703 and UL 2703. Listed systems shall include roof-mounting hardware. The fire classification shall comply with Table 1505.1 based on the type of construction of the building.

Reason:

The purpose of this change is to remedy a potential unintended consequence of adopted reference standards. It is important that roof mounting hardware be part of tested rooftop mounted photovoltaic panel system listings required by IBC Section 1505.9. If such hardware is not included in listings such hardware would be unregulated and mounting methods such as pieces of untreated lumber could potentially be used with unknown impacts on fire-related performance. There is lack of consensus within the roofing industry regarding systems listed according to UL 2703, "Standard for Mounting Systems, Mounting Devices, Clamping/Retention Devices, and Ground Lugs for Use with Flat-Plate Photovoltaic Modules and Panels." UL 2703 is not clear regarding the inclusion of roof-mounting hardware. NRCA has requested and UL has established a work group to issue an official interpretation, but the issue date of the interpretation is open-ended. It seems prudent to add a clarifying statement to code text as we believe it makes clear the intent of the code section.

Cost Impact

The code change proposal will increase the cost of construction .

The magnitude of cost impact cannot be determined until UL issues their interpretation. It is possible some systems may need to be retested with roof-mounting hardware and that some hardware may need to be improved to obtain desired test results.

Internal ID: 1218

S5-18

IBC: 1505.10

Proponent: Jason Wilen AIA CDT RRO, National Roofing Contractors Association (NRCA), representing National Roofing Contractors Association (NRCA) (jwilen@nrca.net)

THIS PROPOSAL WILL BE HEARD BY THE IBC FIRE SAFETY CODE COMMITTEE. SEE THE IBC-FS HEARING AGENDA.

2018 International Building Code

Revise as follows:

[BF] 1505.10 Roof gardens and landscaped roofs. Roof gardens and landscaped roofs shall ~~comply be~~ classified in accordance with Section 1505.1 and comply with Section 1507.16 and shall be installed in accordance with ANSI/SPRI VF-1, Section 317 of the International Fire Code.

Reason:

The purpose of this change is to simplify and to better cross-reference related I-Code sections. IFC Section 317—Rooftop Gardens and Landscaped Roofs references IBC Sections 1505.1 and 1507.16 as does IBC Section 1505.10 where the change is being proposed. The reference to IFC Section 317 makes users aware of related I-Code provisions already on the books. Deleting the reference to ANSI/SPRI VF-1 makes sense because IFC Section 317 contains provisions with the same scope as ANSI/SPRI VF-1, therefore VF-1 is not needed. Additionally, VF-1 is problematic because the portion of the documents subject to a consensus process (2 pages of text) contains multiple references to a 4-page commentary that is not subject to public review.

Cost Impact

The code change proposal will not increase or decrease the cost of construction .

The proposed change does not increase the stringency of the code.

Internal ID: 1221

S6-18

IBC: 1507.3.10 (New), 1507.3.10.1 (New), 1507.3.10.2 (New), 1507.3.10.3 (New), 1507.3.10.4 (New)

Proponent: Amanda Hickman, The Hickman Group, representing RIMA International (amanda@thehickmangroup.com)

THIS PROPOSAL WILL BE HEARD BY THE IBC FIRE SAFETY CODE COMMITTEE. SEE THE IBC-FS HEARING AGENDA.

2018 International Building Code

Delete without substitution:

~~SECTION 1509 RADIANT BARRIERS INSTALLED ABOVE DECK~~

~~**[BF] 1509.1 General.** A *radiant barrier* installed above a deck shall comply with Sections 1509.2 through 1509.4.~~

~~**[BF] 1509.2 Fire testing.** *Radiant barriers* shall be permitted for use above decks where the *radiant barrier* is covered with an *approved* roof covering and the system consisting of the *radiant barrier* and the roof covering complies with the requirements of either FM 4450 or UL 1256.~~

~~**[BF] 1509.3 Installation.** The low emittance surface of the *radiant barrier* shall face the continuous airspace between the *radiant barrier* and the roof covering.~~

~~**[BF] 1509.4 Material standards.** A *radiant barrier* installed above a deck shall comply with ASTM C1313/1313M.~~

Add new text as follows:

1507.3.10 Radiant barrier. Where a radiant barrier is installed above a roof deck under clay or concrete tile, it shall comply with Sections 1507.3.10.1 through 1507.3.10.4

1507.3.10.1 Installation. Radiant barriers shall only be installed between a batten and a counter batten. A low-emittance surface of the radiant barrier shall face the airspace between the radiant barrier and roof deck.

1507.3.10.2 Material fire testing. The radiant barrier material shall have a flame spread index of 25 or less and a smoke-developed index of 450 or less as determined in accordance with ASTM E84 or UL 723, with test specimen preparation and mounting in accordance with ASTM E2599.

1507.3.10.3 Assembly fire testing. The roof assembly, including the radiant barrier, shall comply with the requirements of a Class A, B, or C roof assembly when classified as required by Section 1505.1.

1507.3.10.4 Material standards. Radiant barrier materials shall comply with ASTM C1313/C1313M.

Reason:

This proposal is submitted as a compromise between RIMA International and National Roofing Contractors Association (NRCA). NRCA approached RIMA with an interest to move section 1509 to 1507. The current language in 1509 is adequate; however, in the spirit of consensus, and because radiant barriers are often used in conjunction with concrete or clay tile, the proposed move of the radiant barrier language from 1509 to a new section in section 1507 Clay and Concrete Tile was developed.

The proposed new section 1507.3.10.2 was drafted based on the requirements in Chapter 14 for water resistive barriers: testing the radiant barrier (on its own) to both ASTM E1354 and ASTM E84 test standards. ASTM E2599 test standard is recommended as the test specimen preparation and mounting method since it is specific to radiant barriers (and some other materials); ASTM E2404 is applicable to water resistive barriers.

A fire classification is required for all roof assemblies per Section 1505. Adding the proposed Section 1507.3.10.3 requires assembly testing of the entire roof covering system. Therefore, the addition of the radiant barrier to any roof assembly will result in a fire classification for the roof assembly as required by Section 1505, just like all other roof assemblies.

Cost Impact

The code change proposal will not increase or decrease the cost of construction .

This will neither increase or decrease construction costs as radiant barriers are not mandatory, the proposal only moves 1509 language to 1507; and the revisions are minor.

Staff Analysis: The referenced standards within this proposal are currently referenced in the I-Codes.

Internal ID: 1110

S7-18

IBC: [BF] 1508.1

Proponent: Bill McHugh, The McHugh Company, representing Chicago Roofing Contractors Association (Bill@mc-hugh.us)

THIS PROPOSAL WILL BE HEARD BY THE IBC FIRE SAFETY CODE COMMITTEE. SEE THE IBC-FS HEARING AGENDA.

2018 International Building Code

Revise as follows:

[BF] 1508.1 General. The use of above-deck thermal insulation shall be permitted provided that such insulation is covered with an approved roof covering and passes the tests of NFPA 276 or UL 1256 when tested as an assembly.

Exceptions:

1. Foam plastic roof insulation shall conform to the material and installation requirements of Chapter 26 and separated by an assembly having a minimum 30 minute fire-resistance rating.
2. Where a concrete roof deck is used and the above-deck thermal insulation is covered with an approved roof covering.

Reason:

The purpose of this proposal is to add safety for when foam plastic insulation is allowed to be used on roof assemblies. Foam plastic insulation is a great product but needs additional protection from fire, especially in roofing configurations. It seems in Chapter 26 that there is an exception that allows foam plastic insulation to be direct applied to wood sheathing but not metal decking. Regardless of roof deck type, it is important to protect the building with a 30 minute fire-resistance rated assembly as a thermal barrier.

Cost Impact

The code change proposal will increase the cost of construction .

This proposal will increase the cost of construction by about \$1.00 - \$1.25US per square foot of roofing area.

Internal ID: 1723

S8-18

IBC: [BF] 1508.1

Proponent: Bill McHugh, The McHugh Company, representing Chicago Roofing Contractors Association (Bill@mc-hugh.us)

THIS PROPOSAL WILL BE HEARD BY THE IBC FIRE SAFETY CODE COMMITTEE. SEE THE IBC-FS HEARING AGENDA.

2018 International Building Code

[BF] 1508.1 General. The use of above-deck thermal insulation shall be permitted provided that such insulation is covered with an approved roof covering and passes the tests of NFPA 276 or UL 1256 when tested as an assembly.

Exceptions:

1. Foam plastic roof insulation shall conform to the material and installation requirements of Chapter 26 and be separated from the interior of the building by 1/2-inch gypsum board.
2. Where a concrete roof deck is used and the above-deck thermal insulation is covered with an approved roof covering.

Reason:

The purpose of this proposal is to add safety for when foam plastic roof insulation is allowed to be used on roof assemblies. Foam plastic insulation is a great product but needs additional protection from fire, especially in roofing configurations. It seems in Chapter 26, there is an exception that allows foam plastic insulation to be direct applied to wood sheathing, but not to metal decks. Regardless of the deck type, there can be fire transmitted to the plastic roof insulation, hence the addition of 1/2" gypsum board in cases where the plastic insulation is used.

Cost Impact

The code change proposal will increase the cost of construction .

This proposal will increase the cost of the roof by \$1.00US - \$1.25US per square foot of roof area when mechanically fastened.

Internal ID: 1702

S9-18

IBC: 1508.1

Proponent: Bill McHugh, representing Chicago Roofing Contractors Association (billmchugh-jr@att.net)

THIS PROPOSAL WILL BE HEARD BY THE IBC FIRE SAFETY CODE COMMITTEE. SEE THE IBC-FS HEARING AGENDA.

2018 International Building Code

Revise as follows:

[BF] 1508.1 General. The use of above-deck thermal insulation shall be permitted provided that such insulation is covered with an approved roof covering and passes the tests of NFPA 276 or UL 1256 when tested as an assembly.

Exceptions:

1. Foam plastic roof insulation shall conform to the material and installation requirements of Chapter 26.
2. Where a concrete or composite metal and concrete roof deck is used and the above-deck thermal insulation is covered with an approved roof covering.

Reason:

The purpose of this proposal is to add an option to the allowable exceptions in the code. Currently the exception is limited to concrete roof deck and does not include a composite metal and concrete roof deck.

Cost Impact

The code change proposal will not increase or decrease the cost of construction .

This proposal does not increase the cost of construction as it provides an alternative to the type of concrete roof deck used for foam plastic insulation.

Internal ID: 1720

S10-18

IBC: 1510.1.1, 1510.2, 1510.2.1, 1510.2.2

Proponent: Jay Hyde, representing Sacramento Valley Association of Building Officials
(jhyde@mogaveroarchitects.com)

THIS PROPOSAL WILL BE HEARD BY THE IBC GENERAL CODE COMMITTEE. SEE THE IBC-G HEARING AGENDA.

2018 International Building Code

Revise as follows:

1510.1.1 Area limitation. The aggregate area of penthouses and other enclosed rooftop structures shall not exceed one-third the area of the supporting roof deck. The aggregate area of Occupied Rooftop Structures and Penthouses in conformance with Section 1502.2 shall not exceed ten percent of the area of the roof. Such penthouses and other enclosed rooftop structures shall not be required to be included in determining the building area or number of stories as regulated by Section 503.1. The area of such penthouses shall not be included in determining the fire area specified in Section 901.7.

[BG] 1510.2 Penthouses and Occupied Rooftop Structures.. Penthouses and Occupied Rooftop Structures in compliance with Sections 1510.2.1 through 1510.2.5 shall be considered as a portion of the story directly below the roof deck on which such penthouses are located. Other penthouses shall be considered as an additional story of the building.

[BG] 1510.2.1 Height above roof deck. Penthouses and occupied rooftop structures constructed on buildings of other than Type I construction shall not exceed 18 feet (5486 mm) in height above the roof deck as measured to the average height of the roof of the penthouse. Penthouses located on the roof of buildings of Type I construction shall not be limited in height.

Exception: Where used to enclose tanks or elevators that travel to the roof level, penthouses shall be permitted to have a maximum height of 28 feet (8534 mm) above the roof deck.

[BG] 1510.2.2 Use limitations.

1. Penthouses shall not be used for purposes other than the shelter of mechanical or electrical equipment, tanks, elevators and related machinery, or vertical shaft openings in the roof assembly.
2. Occupied rooftop structures shall be accessory to the adjacent occupied roof in conformance with Section 508.2.

Reason:

Occupied roofs generally require some support space for functionality. The IBC recognizes the importance of limited area accessory occupancies within a building. This code change proposal would allow similar reasoning to be applied to occupied roofs. The 10% limitation is the same limitation for accessory occupancies in IBC Section 508.2.3.

Cost Impact

The code change proposal will not increase or decrease the cost of construction .

This proposal is permissive, it permits a designer to include a limited-scope occupied penthouse as an accessory to an adjacent roof but it does not require an accessory occupied penthouse. If a designer chooses to include an occupied penthouse, the cost of construction will increase but the designer may not choose to include a occupied penthouse in the project, in which instance there would be no change in cost.

Internal ID: 1406

S11-18

IBC: 1510.2.4

Proponent: Homer Maiel, representing ICC Tri-Chapter (Peninsula, East Bay, Monterey Bay) (hmaiel@gmail.com)

THIS PROPOSAL WILL BE HEARD BY THE IBC GENERAL CODE COMMITTEE. SEE THE IBC-G HEARING AGENDA.

2018 International Building Code

[BG] 1510.2.4 Type of construction. Penthouses shall be constructed ~~with walls, floors and roofs of building elements~~ as required for the type of construction of the building on which such penthouses are built.

Exceptions:

1. On buildings of Type I construction, the exterior walls and roofs of penthouses with a *fire separation distance* greater than 5 feet (1524 mm) and less than 20 feet (6096 mm) shall be permitted to have not less than a 1-hour fire-resistance rating. The exterior walls and roofs of penthouses with a fire separation distance of 20 feet (6096 mm) or greater shall not be required to have a fire-resistance rating.
2. On buildings of Type I construction two stories or less in height above grade plane or of Type II construction, the exterior walls and roofs of penthouses with a *fire separation distance* greater than 5 feet (1524 mm) and less than 20 feet (6096 mm) shall be permitted to have not less than a 1-hour fire-resistance rating or a lesser fire-resistance rating as required by Table 602 and be constructed of *fire-retardant-treated wood*. The exterior walls and roofs of penthouses with a *fire separation distance* of 20 feet (6096 mm) or greater shall be permitted to be constructed of fire-retardant-treated wood and shall not be required to have a fire-resistance rating. Interior framing and walls shall be permitted to be constructed of *fire-retardant-treated wood*.
3. On buildings of Type III, IV or V construction, the exterior walls of penthouses with a *fire separation distance* greater than 5 feet (1524 mm) and less than 20 feet (6096 mm) shall be permitted to have not less than a 1-hour fire-resistance rating or a lesser fire-resistance rating as required by Table 602. On buildings of Type III, IV or VA construction, the exterior walls of penthouses with a *fire separation distance* of 20 feet (6096 mm) or greater shall be permitted to be of heavy timber construction complying with Sections 602.4 and 2304.11 or noncombustible construction or *fire-retardant-treated wood* and shall not be required to have a fire-resistance rating.

Reason:

The addition of "Building element" is more fitting. See Table 601.

Cost Impact

The code change proposal will not increase or decrease the cost of construction .

This proposal will not increase or decrease the cost of construction because the proposal simply substitutes terms to more clearly reflect the intent of the code.

Internal ID: 1481

S12-18

IBC: 1510.7.2

Proponent: Jason Wilen AIA CDT RRO, National Roofing Contractors Association (NRCA), representing National Roofing Contractors Association (NRCA) (jwilen@nrca.net)

THIS PROPOSAL WILL BE HEARD BY THE IBC GENERAL CODE COMMITTEE. SEE THE IBC-G HEARING AGENDA.

2018 International Building Code

Revise as follows:

[BG] 1510.7.2 Photovoltaic panels and modules. Rooftop-mounted *photovoltaic panels* and *modules* shall be *listed* and labeled in accordance with UL 1703 and UL 2703 and shall be installed in accordance with the manufacturer's instructions.

Reason:

Last code cycle a reference to UL 2703 was added to IBC Section 1505.9—Rooftop mounted photovoltaic panel systems. A reference to UL 2703 should also be added to IBC 1510.7.2—Photovoltaic panels and modules to be consistent with the requirements in IBC Section 1505 as both sections are dealing with the same topic.

Cost Impact

The code change proposal will not increase or decrease the cost of construction .

The proposed change does not increase the stringency of the code.

Staff Analysis: The standard referenced in this proposal, UL 2703, is currently referenced in the I-Codes.

Internal ID: 1198

S13-18

IBC: 1510.7, 1510.7.1, 1510.7.2, 1512, 1512.1

Proponent: Joseph Cain, Solar Energy Industries Association (SEIA), representing Solar Energy Industries Association (JoeCainPE@gmail.com)

THIS PROPOSAL WILL BE HEARD BY THE IBC GENERAL CODE COMMITTEE. SEE THE IBC-G HEARING AGENDA.

2018 International Building Code

Delete without substitution:

~~**[BG] 1510.7 Photovoltaic panels and modules.** Rooftop-mounted *photovoltaic panels* and *modules* shall be designed in accordance with this section.~~

~~**[BG] 1510.7.1 Fire classification.** Rooftop-mounted *photovoltaic panels* and *modules* shall have the fire classification in accordance with Section 1505.9.~~

~~**[BG] 1510.7.2 Photovoltaic panels and modules.** Rooftop-mounted *photovoltaic panels* and *modules* shall be *listed* and labeled in accordance with UL 1703 and shall be installed in accordance with the manufacturer's instructions.~~

~~**SECTION 1512 PHOTOVOLTAIC PANELS AND MODULES**~~

~~**1512.1 Photovoltaic panels and modules.** *Photovoltaic panels* and *modules* installed on a roof or as an integral part of a roof assembly shall comply with the requirements of this code and the International Fire Code.~~

Reason:

This proposal seeks to strike out IBC Sections 1510.7 and 1512, as they are entirely redundant with corresponding portions of IBC Section 3111. Section 3111 was expanded and improved during the 2018 IBC development cycle, with the intent of providing and improved and consolidated "road map" of requirements for solar energy systems. There is nothing unique in Section 1510.7 or 1512. In fact, these sections fall short of the improved language in Section 3111.

Section 1510.7 is redundant with IBC Section 3111.3:

1510.7 Photovoltaic panels and modules. Rooftop-mounted photovoltaic panels and modules shall be designed in accordance with this section.

3111.3 Photovoltaic solar energy systems. Photovoltaic solar energy systems shall be designed and installed in accordance with this section, the International Fire Code, NFPA 70 and the manufacturers installation instructions.

Section 1510.7.1 is redundant with IBC Section 3111.3.2:

1510.7.1 Fire classification. Rooftop-mounted photovoltaic panels and modules shall have the fire classification in accordance with Section 1505.9.

3111.3.2 Fire classification. Rooftop-mounted photovoltaic systems shall have a fire classification in accordance with Section 1505.9. Building-integrated photovoltaic systems shall have a fire classification in accordance with Section 1505.8.

Section 1510.7.2 is redundant with IBC Section 3111.3.1:

1510.7.2 Photovoltaic panels and modules. Rooftop-mounted photovoltaic panels and modules shall be listed and labeled in accordance with UL 1703 and shall be installed in accordance with manufacturer's instructions.

3111.3.1 Equipment. Photovoltaic panels and modules shall be listed and labeled in accordance with UL 1703. Inverters shall be listed and labeled in accordance with UL 1741. Systems connected to the utility grid shall use inverters listed for utility interaction.

IBC Section 1512 is redundant with IBC Section 3111.3:

1512.1 Photovoltaic panels and modules. Photovoltaic panels and modules installed on a roof or as an integral part of a roof assembly shall comply with the requirements of this code and the International Fire Code.

3111.3 Photovoltaic solar energy systems. Photovoltaic solar energy systems shall be designed and installed in accordance with this section, the International Fire Code, NFPA 70 and the manufacturers installation instructions.

In each case, IBC Section 3111 does a better job of listing requirements in a cohesive manner. Sections 1510.7 and 1512 fall short of the guidance provided in the "road map" of Section 3111. The important technical requirements in Sections 1505.8 and 1505.9 remain in Chapter 15, and they are referenced in Section 3111.

Cost Impact

The code change proposal will not increase or decrease the cost of construction .

This proposals only removes redundant language from the IBC, and does not change any technical requirement.

Internal ID: 1999

S14-18

IBC: 1705.14

Proponent: Bill McHugh, The McHugh Company, representing National Fireproofing Contractors Association (Bill@mc-hugh.us)

THIS PROPOSAL WILL BE HEARD BY THE IBC FIRE SAFETY CODE COMMITTEE. SEE THE IBC-FS HEARING AGENDA.

2018 International Building Code

Revise as follows:

[BF] 1705.14 Sprayed fire-resistant materials. *Special inspections* and tests of sprayed fire-resistant materials applied to floor, roof and wall assemblies and structural members shall be performed in accordance with Sections 1705.14.1 through 1705.14.6. *Special inspections* shall be based on the fire-resistance design as designated in the *approved construction documents*. The tests set forth in this section shall be based on samplings from specific floor, roof and wall assemblies and structural members. *Special inspections* and tests shall be performed after the rough installation of electrical, automatic sprinkler, mechanical and plumbing systems and suspension systems for ceilings, and before concealed, where applicable.

Reason:

The installation of SFRM fireproofing takes place early in the project when there is clear access to the beams, columns, trusses and horizontal assemblies. This installation to the manufacturers installation instructions and the listing needs to take place before the installation of the mechanical, electrical, plumbing (MEP) and ceilings takes place. SFRM fireproofing application does not take place while the MEP or ceiling contractors are working. It's not efficient.

This proposal aims to clarify that the fireproofing inspection takes place while the SFRM fireproofing application takes place rather than after. It is much more costly to repair any areas that are not in compliance with the listing if the MEP and ceilings contractors have mobilized.

Cost Impact

The code change proposal will not increase or decrease the cost of construction .

This proposal makes the code reflect the way that SFRM Fireproofing is inspected currently. If the inspection is to take lace after the SFRM contractor has demobilized, cost of construction will increase.

Internal ID: 1974

S15-18

IBC: 1705.14

Proponent: Bill McHugh, The McHugh Company, representing National Fireproofing Contractors Association (billmchugh-jr@att.net)

THIS PROPOSAL WILL BE HEARD BY THE IBC FIRE SAFETY CODE COMMITTEE. SEE THE IBC-FS HEARING AGENDA.

2018 International Building Code

Revise as follows:

[BF] 1705.14 Sprayed fire-resistant materials. *Special inspections* and tests of sprayed fire-resistant materials applied to floor, roof and wall assemblies and structural members shall be performed in accordance with Sections 1705.14.1 through 1705.14.6. *Special inspections* shall be based on the fire-resistance design as designated in the *approved construction documents*. The tests set forth in this section shall be based on samplings from specific floor, roof and wall assemblies and structural members. *Special inspections* and tests shall be performed during construction with an addition visual inspection after the rough installation of electrical, automatic sprinkler, mechanical and plumbing systems and suspension systems for ceilings, where applicable.

Reason:

The way the current language reads is confusing and contrary to the way that fireproofing is currently inspected. The special inspection process for sprayed fire-resistive materials (SFRM) fireproofing has been conducted during the SFRM installation process for decades. The code seems to imply that the inspection not take place during construction and instead be performed at a much later time in the project. The code states that the inspection shall take place after the installation of the "rough in" of Mechanical, Electrical and Plumbing (MEP) and ceilings with very strong language.

The purpose of this code proposal is to clarify that the SFRM inspection takes place at the installation phase as is commonly practiced today on jobsites. The proposal also states that an additional visual inspection takes place before the "rough in" as stated in the code. This is to find any areas where the MEP or ceiling contractors might have unintentionally removed SFRM fireproofing and repair those areas.

The inspection after rough installation of various mechanical, electrical and plumbing (MEP), ceiling assembly items as stated in the code is more expensive and not practical. Should it be determined that the complete inspection only be performed after the MEP "rough in", the repairs made to deficiencies would increase the cost of construction significantly. The fireproofing applicator is usually demobilized once this MEP and ceiling "rough in" has started. This means another mobilization. It also makes repairs, if required, difficult or impossible to access due to pipes, cables, ductwork, and ceilings blocking the ability to get to those places to spray fire-resistive materials.

Cost Impact

The code change proposal will not increase or decrease the cost of construction .

Should it be determined that the SFRM Special inspection take place only after the "rough in" of the mechanical, electrical and plumbing and or ceilings, cost of construction will increase.

Internal ID: 1970

S16-18

IBC: 1705.14

Proponent: Bill McHugh, The McHugh Company, representing National Fireproofing Contractors Association (Bill@mc-hugh.us)

THIS PROPOSAL WILL BE HEARD BY THE IBC FIRE SAFETY CODE COMMITTEE. SEE THE IBC-FS HEARING AGENDA.

2018 International Building Code

Revise as follows:

[BF] 1705.14 Sprayed fire-resistant materials. *Special inspections* and tests of sprayed fire-resistant materials applied to floor, roof and wall assemblies and structural members shall be performed in accordance with Sections 1705.14.1 through 1705.14.6. *Special inspections* shall be based on the fire-resistance design as designated in the *approved construction documents*. The tests set forth in this section shall be based on samplings from specific floor, roof and wall assemblies and structural members. *Special inspections* and tests shall be performed after the rough installation of electrical, automatic sprinkler, mechanical and plumbing systems and suspension systems for ceilings, where applicable. The required sample size shall not exceed 110% of that specified by the referenced standards in Sections 1705.14.4.1 through 1704.14.4.9.

Reason:

The code states that a minimum amount of inspection is to take place but not a maximum. The inspection agency has no limit to the amount of inspection that can be conducted, which seems unreasonable. As such, this code proposal brings a degree of reason and prevents "over-inspection" to the special inspection process and undue cost to the building owner and manager.

Cost Impact

The code change proposal will not increase or decrease the cost of construction .

This code proposal changes a variable expense with an unknown maximum into a more fixed amount due to the limits of inspection.

Internal ID: 1967

S17-18

IBC: 1705.14, 1705.14.1, 1705.14.2, 1705.14.3, 1705.14.4, 1705.14.4.1, 1705.14.4.2, 1705.14.4.3, 1705.14.4.4, 1705.14.4.5, 1705.14.4.6, 1705.14.4.7, 1705.14.4.8, 1705.14.4.9, 1705.14.5, 1705.14.6, 1705.14.6.1, 1705.14.6.2, 1705.14.6.3, Chapter 35, ordinal

Proponent: Bill McHugh, The McHugh Company, representing National Fireproofing Contractors Association (Bill@mc-hugh.us)

THIS PROPOSAL WILL BE HEARD BY THE IBC FIRE SAFETY CODE COMMITTEE. SEE THE IBC-FS HEARING AGENDA.

2018 International Building Code

Revise as follows:

[BF] 1705.14 Sprayed fire-resistant materials. *Special inspections* and tests of sprayed fire-resistant materials applied to floor, roof and wall assemblies and structural members shall be performed in accordance with Sections 1705.14.1 through 1705.14.6. *Special inspections* shall be based on the fire-resistance design as designated in the *approved construction documents*. The tests set forth in this section shall be based on samplings from specific floor, roof and wall assemblies and structural members. *Special inspections* and tests shall be performed in accordance with ASTM XXXX after the rough installation of electrical, automatic sprinkler, mechanical and plumbing systems and suspension systems for ceilings, where applicable.

Delete without substitution:

~~**[BF] 1705.14.1 Physical and visual tests.** The *special inspections* and tests shall include the following to demonstrate compliance with the listing and the *fire resistance rating*:~~

- ~~1. Condition of substrates.~~
- ~~2. Thickness of application.~~
- ~~3. Density in pounds per cubic foot (kg/m³).~~
- ~~4. Bond strength adhesion/cohesion.~~
- ~~5. Condition of finished application.~~

~~**[BF] 1705.14.2 Structural member surface conditions.** The surfaces shall be prepared in accordance with the *approved fire resistance design* and the written instructions of *approved manufacturers*. The prepared surface of structural members to be sprayed shall be inspected by the special inspector before the application of the sprayed fire-resistant material.~~

~~**[BF] 1705.14.3 Application.** The substrate shall have a minimum ambient temperature before and after application as specified in the written instructions of *approved manufacturers*. The area for application shall be ventilated during and after application as required by the written instructions of *approved manufacturers*.~~

~~**[BF] 1705.14.4 Thickness.** Not more than 10 percent of the thickness measurements of the sprayed fire-resistant materials applied to floor, roof and wall assemblies and structural members shall be less than the thickness required by the *approved fire resistance design*, and none shall be less than the minimum allowable thickness required by Section 1705.14.4.1.~~

~~**[BF] 1705.14.4.1 Minimum allowable thickness.** For design thicknesses 1 inch (25 mm) or greater, the minimum allowable individual thickness shall be the design thickness minus 1/4 inch (6.4 mm). For design thicknesses less than 1 inch (25 mm), the minimum allowable individual thickness shall be the design thickness minus 25 percent. Thickness shall be determined in accordance with ASTM E605. Samples of the sprayed fire-resistant materials shall be selected in accordance with Sections 1705.14.4.2 and 1705.14.4.3.~~

~~**[BF] 1705.14.4.2 Floor, roof and wall assemblies.** The thickness of the sprayed fire-resistant material applied to floor, roof and wall assemblies shall be determined in accordance with ASTM E605, making not less than four measurements for each 1,000 square feet (93 m²) of the sprayed area, or portion thereof, in each story.~~

~~**[BF] 1705.14.4.3 Cellular decks.** Thickness measurements shall be selected from a square area, 12 inches by 12 inches (305 mm by 305 mm) in size. Not fewer than four measurements shall be made, located symmetrically within the square area.~~

[BF] 1705.14.4.4 Fluted decks. Thickness measurements shall be selected from a square area, 12 inches by 12 inches (305 mm by 305 mm) in size. Not fewer than four measurements shall be made, located symmetrically within the square area, including one each of the following: valley, crest and sides. The average of the measurements shall be reported.

[BF] 1705.14.4.5 Structural members. The thickness of the sprayed fire resistant material applied to structural members shall be determined in accordance with ASTM E605. Thickness testing shall be performed on not less than 25 percent of the structural members on each floor.

[BF] 1705.14.4.6 Beams and girders. At beams and girders thickness measurements shall be made at nine locations around the beam or girder at each end of a 12-inch (305 mm) length.

[BF] 1705.14.4.7 Joists and trusses. At joists and trusses, thickness measurements shall be made at seven locations around the joist or truss at each end of a 12-inch (305 mm) length.

[BF] 1705.14.4.8 Wide-flanged columns. At wide flanged columns, thickness measurements shall be made at 12 locations around the column at each end of a 12-inch (305 mm) length.

[BF] 1705.14.4.9 Hollow structural section and pipe columns. At hollow structural section and pipe columns, thickness measurements shall be made at not fewer than four locations around the column at each end of a 12-inch (305 mm) length.

[BF] 1705.14.5 Density. The density of the sprayed fire resistant material shall be not less than the density specified in the approved fire resistance design. Density of the sprayed fire resistant material shall be determined in accordance with ASTM E605. The test samples for determining the density of the sprayed fire resistant materials shall be selected as follows:

1. From each floor, roof and wall assembly at the rate of not less than one sample for every 2,500 square feet (232 m²) or portion thereof of the sprayed area in each story.
2. From beams, girders, trusses and columns at the rate of not less than one sample for each type of structural member for each 2,500 square feet (232 m²) of floor area or portion thereof in each story.

[BF] 1705.14.6 Bond strength. The cohesive/adhesive bond strength of the cured sprayed fire resistant material applied to floor, roof and wall assemblies and structural members shall be not less than 150 pounds per square foot (psf) (7.18 kN/m²). The cohesive/adhesive bond strength shall be determined in accordance with the field test specified in ASTM E736 by testing in-place samples of the sprayed fire resistant material selected in accordance with Sections 1705.14.6.1 through 1705.14.6.3.

[BF] 1705.14.6.1 Floor, roof and wall assemblies. The test samples for determining the cohesive/adhesive bond strength of the sprayed fire resistant materials shall be selected from each floor, roof and wall assembly at the rate of not less than one sample for every 2,500 square feet (232 m²) of the sprayed area, or portion thereof, in each story.

[BF] 1705.14.6.2 Structural members. The test samples for determining the cohesive/adhesive bond strength of the sprayed fire resistant materials shall be selected from beams, girders, trusses, columns and other structural members at the rate of not less than one sample for each type of structural member for each 2,500 square feet (232 m²) of floor area or portion thereof in each story.

[BF] 1705.14.6.3 Primer, paint and encapsulant bond tests. Bond tests to qualify a primer, paint or encapsulant shall be conducted where the sprayed fire resistant material is applied to a primed, painted or encapsulated surface for which acceptable bond strength performance between these coatings and the fire resistant material has not been determined. A bonding agent approved by the SFRM manufacturer shall be applied to a primed, painted or encapsulated surface where the bond strengths are found to be less than required values.

Add new standard(s) follows:

CHAPTER 35 REFERENCED STANDARDS

ASTM

ASTM International
100 Barr Harbor Drive, P.O. Box
C700
West Conshohocken PA 19428-

Draft Standard WK54567 - 2018:

Practice for the On-Site Inspection of Installed Fire Resistive Material with Annex and Appendix

Reason:

Special inspection for sprayed fire-resistive materials (SFRM) fireproofing has been in the International Building Code for many years. To date, the requirements have been prescriptive and in the IBC, Chapter 17. Over the past few years, the contractors, manufacturers and consultants of SFRM Fireproofing have come together to build an inspection standard at ASTM. The document is the result of the industry efforts to come to consensus with this new standard. We respectfully submit this document for insertion into the 2021 IBC.

Cost Impact

The code change proposal will not increase or decrease the cost of construction .

The reason the proposal will not increase the cost of construction is that the methods used for inspection are the same as is in Chapter 17 of the IBC currently.

Analysis: A review of the standard proposed for inclusion in the code, ASTM - WK54567-2018, with regard to the ICC criteria for referenced standards (Section 3.6 of CP#28) will be posted on the ICC website on or before April 2, 2018.

Internal ID: 1934

S18-18

IBC: 1705.15, Chapter 35, ordinal

Proponent: Bill McHugh, The McHugh Company, representing National Fireproofing Contractors Association (Bill@mc-hugh.us)

THIS PROPOSAL WILL BE HEARD BY THE IBC FIRE SAFETY CODE COMMITTEE. SEE THE IBC-FS HEARING AGENDA.

2018 International Building Code

Revise as follows:

[BF] 1705.15 Mastic and intumescent fire-resistant coatings. *Special inspections* and tests for mastic and intumescent fire-resistant coatings applied to structural elements and decks shall be performed in accordance with ~~AWCI-12-B. Draft ASTM Standard WK54767. Draft ASTM Standard WK54567.~~ *Special inspections* and tests shall be based on the fire-resistance design as designated in the *approved construction documents*.

Add new standard(s) follows:

CHAPTER 35 REFERENCED STANDARDS

ASTM

ASTM International
100 Barr Harbor Drive, P.O. Box
C700
West Conshohocken PA 19428-
2959
US

Draft Standard WK54567 - 2018:

Practice for the On-Site Inspection of Installed Fire Resistive Material with Annex and Appendix

Reason:

The Intumescent fire-resistant coatings industry - contractors, manufacturers and consultants - worked together at ASTM to build a new consensus standard for special inspection of mastic and intumescent fire-resistant coatings. We respectfully submit this standard for insertion into the International Building Code, Chapter 17.

Cost Impact

The code change proposal will not increase or decrease the cost of construction .

This proposal takes a new standard and improves on existing documents in the code resulting in uniform special inspection of fire-resistant coatings.

Analysis: A review of the standard proposed for inclusion in the code, ASTM - WK54567-2018, with regard to the ICC criteria for referenced standards (Section 3.6 of CP#28) will be posted on the ICC website on or before April 2, 2018.

Internal ID: 1958

S19-18

IBC: 1705.15

Proponent: Bill McHugh, The McHugh Company, representing National Fireproofing Contractors Association (Bill@mc-hugh.us)

THIS PROPOSAL WILL BE HEARD BY THE IBC FIRE SAFETY CODE COMMITTEE. SEE THE IBC-FS HEARING AGENDA.

2018 International Building Code

Revise as follows:

[BF] 1705.15 Mastic and intumescent fire-resistant coatings. *Special inspections* and tests for mastic and intumescent fire-resistant coatings applied to structural elements and decks shall be performed in accordance with AWCI 12-B. *Special inspections* and tests shall be based on the fire-resistance design as designated in the *approved construction documents*. Special Inspections and tests shall be performed after the rough installation of electrical, automatic sprinkler, mechanical and plumbing systems and suspension systems for ceilings, and before concealed, where applicable.

Reason:

The special inspection of fireproofing needs to take place before the mechanical, electrical and plumbing, sprinkler, suspension systems and ceilings are 'roughed in' or installed. This proposal is to clarify in the code when the inspection is to take place, which is both as the fireproofing is installed and also visually after the rough in takes place.

Cost Impact

The code change proposal will not increase or decrease the cost of construction .

This proposal clarifies that inspection of fireproofing takes place as it currently does now meaning no increase in cost.

Internal ID: 2142

S20-18

IBC: 1705.15

Proponent: Bill McHugh, The McHugh Company, representing National Fireproofing Contractors Association (Bill@mc-hugh.us)

THIS PROPOSAL WILL BE HEARD BY THE IBC FIRE SAFETY CODE COMMITTEE. SEE THE IBC-FS HEARING AGENDA.

2018 International Building Code

Revise as follows:

[BF] 1705.15 Mastic and intumescent fire-resistant coatings. *Special inspections* and tests for mastic and intumescent fire-resistant coatings applied to structural elements and decks shall be performed in accordance with AWCI 12-B. *Special inspections* and tests shall be based on the fire-resistance design as designated in the *approved construction documents*. Additional inspections and tests shall not exceed an additional amount of 10 percent than required in AWCI-12-B.

Reason:

The code states that a minimum amount of inspection is to take place but not a maximum amount of inspection. The inspection agency has no limit to the amount of inspection that can be conducted if this is not added to this section on special inspections. The maximum number comes from another standard that has been in the IBC Special Inspection Section for the past code cycles, ASTM E 2174 for Firestop Special Inspection.

Cost Impact

The code change proposal will not increase or decrease the cost of construction .

This proposal limits the amount of inspection to a reasonable amount of maximum inspection to the code. It changes a variable expense to the building owner into a more fixed cost item.

Staff Analysis:The referenced standard within this proposal, AWCI 12-B, is currently referenced in the I-codes.

Internal ID: 2130

S21-18

IBC: 1705.17

Proponent: William Koffel, representing Firestop Contractors International Association (wkoffel@koffel.com)

THIS PROPOSAL WILL BE HEARD BY THE IBC FIRE SAFETY CODE COMMITTEE. SEE THE IBC-FS HEARING AGENDA.

2018 International Building Code

Revise as follows:

[BF] 1705.17 Fire-resistant penetrations and joints. In high-rise buildings ~~or~~ in buildings assigned to *Risk Category III or IV, or fire areas containing Group R occupancies with an occupant load greater than 250, special inspections for through-penetrations, membrane penetration firestops, fire-resistant joint systems and perimeter fire barrier systems that are tested and listed* in accordance with Sections 714.4.1.2, 714.5.1.2, 715.3 and 715.4 shall be in accordance with Section 1705.17.1 or 1705.17.2.

Reason:

Fire resistance rated compartmentation is a critical fire protection feature in many buildings with Group R occupancies. When through penetration firestop systems and fire resistant joint systems are not properly installed, the integrity of the compartmentation is compromised. The existing requirement for special inspections is proposed to be expanded to include larger buildings with Group R occupancies. The occupant load of 250 is consistent with what is used to define Group E occupancies that are Category III. Without this change, the special inspection requirement would only apply to Group R occupancies in high-rise buildings.

Cost Impact

The code change proposal will increase the cost of construction .

The addition of this special inspection requirement does increase the cost of construction which will vary based on the quality management system of the firestop contractor.

Internal ID: 2361

S22-18

IBC: 1705.19 (New)

Proponent: Brian Tollisen, Division of Building Standards and Codes, NYS Dept. of State, representing Division of Building Standards and Codes, New York State Department of State (Brian.Tollisen@dos.ny.gov)

THIS PROPOSAL WILL BE HEARD BY THE INTERNATIONAL FIRE CODE COMMITTEE. SEE THE IFC HEARING AGENDA.

2018 International Building Code

Add new text as follows:

1705.19 Electrical Construction. Electrical components, appliances, equipment and systems governed by NFPA 70 shall be inspected by an approved special inspector with expertise in NFPA 70 and electrical construction.

Reason:

The inspection of electrical construction is an activity that many building officials do not have the expertise to complete. This type of inspection should be included as a special inspection in Chapter 17.

Cost Impact

The code change proposal will increase the cost of construction .

Since this is a new requirement, it is assumed that it will add cost to a construction project.

Staff Analysis: The referenced standard in this proposal, NFPA 70, is currently referenced in the I-Codes.

Internal ID: 1419

2018 GROUP A – PROPOSED CHANGES TO THE INTERNATIONAL FIRE CODE

FIRE CODE COMMITTEE

Dan Weed, CBO, Chair

Rep: City of Victor, CO
Building Official
Colorado Code Consulting, LLC
Denver, CO

Michael E. Whalen, Vice Chair

Construction Official
New Jersey Department of Community Affairs
Codes and Standards
Trenton, NJ

Michael W. Evans

Rep: International Association of Fire Chiefs
Deputy Fire Chief
Brighton Area Fire Authority
Brighton, MI

Sam Francis

National Programs Director
American Wood Council
West Grove, PA

Barry Grieve, CBO

Bldg. Regulatory & Strategy Lead
Target Corporation
Minneapolis, MN

Howard Hopper, FPE

Regulatory Services Program Manager
UL LLC
Fremont, CA

Randall Metz

Rep: Southern California Fire Prevention
Officers Association-ICC Chapter
Fire Marshal
Carlsbad Fire Department
Carlsbad, CA

Derek Murgatroyd, PE

Rep: National Association of State Fire
Marshals
Fire Protection Engineer
Office of the Maryland State Fire Marshal/
Southern Regional Office
Prince Frederick, MD

David R. Owens, CBO, C. I.

Rep: National Association of Home Builders
Managing Member
Owens Inspection Services, LLC
Palmer, AK

Sarah A. Rice, CBO

Project Manager/Partner
The Preview Group Inc.
Cincinnati, OH

Greg Rogers, FMD

Rep: International Association of Fire Chiefs
Fire Marshal
Division Chief/Fire Marshal
Spokane Valley Fire Department
Spokane Valley, WA

Stephen Rondinelli, AIA

Rondinelli Life Safety
Lakewood, CO

Heather Roth, PE

Rep: National Association of State Fire
Marshals
Fire Protection Engineer 2
NYS Office of Fire Prevention and Control
Rochester, NY

Marc Sampson

Assistant Fire Marshal
Longmont Fire Department
Longmont, CO

Scott Stookey

Engineer A-Hazardous Materials
Austin Fire Department
Austin, TX

Staff Secretariats:

Beth Tubbs, PE, FSFPE

Senior Staff Engineer
Codes and Standards Development
ICC - Boston Field Office
Boston, MA

Keith Enstrom, PE
Staff Engineer
International Code Council
Central Regional Office
Country Club Hills, IL

TENTATIVE ORDER OF DISCUSSION 2018 PROPOSED CHANGES TO THE INTERNATIONAL FIRE CODE

The following is the tentative order in which the proposed changes to the code will be discussed at the public hearings. Proposed changes which impact the same subject have been grouped to permit consideration in consecutive changes.

Proposed change numbers that are indented are those which are being heard out of numerical order. Indentation does not necessarily indicate that one change is related to another. Proposed changes may be grouped for purposes of discussion at the hearing at the discretion of the chair. Note that some F code change proposals may not be included on this list, as they are being heard by another committee.

Numbers Not Used

F255-18

F257-18

WUIC

WUIC1-18	F22-18	F53-18	F84-18
WUIC2-18	F23-18	F54-18	F85-18
WUIC3-18	PM8-18 Part II	F55-18	F86-18
WUIC4-18	F24-18	F56-18	F87-18
WUIC5-18	F25-18	G91-18	F88-18
WUIC6-18	F26-18	F57-18	F89-18
WUIC7-18	F27-18	F58-18	F90-18
WUIC8-18	F28-18	F59-18	F91-18
WUIC9-18	F29-18	F60-18	G71-18 Part II
WUIC10-18	F30-18	F61-18	F21-18
WUIC11-18	F31-18	F62-18	F92-18 Part I
WUIC12-18	F32-18	F63-18	F93-18
WUIC13-18	F33-18	F64-18	F94-18
WUIC14-18	F34-18	F65-18	F95-18
WUIC15-18	F35-18	F66-18	F96-18
WUIC16-18	F36-18	F67-18	G67-18

IFC

F1-18	F37-18	S22-18	F97-18
F8-18	F38-18	F68-18	F4-18 Part I
F9-18	F39-18	F69-18	F98-18
F10-18	F40-18	F70-18	F99-18
F6-18	F41-18	F71-18	F100-18
F11-18	F42-18	F72-18	F101-18
F12-18	F43-18	F73-18	F102-18
F13-18	F44-18	F74-18	F103-18
F14-18 Part I	F2-18	F75-18	F104-18
F15-18	F45-18	F76-18	F105-18
F16-18	F46-18	F77-18	F106-18
F17-18	F47-18	F78-18	F107-18
F18-18	F48-18	F79-18 Part I	F108-18
F19-18	F49-18	F80-18	F109-18
F20-18	F50-18	F81-18	F110-18
	F51-18	F82-18	F111-18
	F52-18	F83-18 Part I	F112-18

F113-18	F168-18	F215-18	F267-18 Part I
F114-18	F169-18	F216-18	F271-18
F115-18	F170-18	F217-18	F272-18
F116-18	F171-18	F218-18	F273-18
F117-18	F172-18	F219-18	F274-18
F118-18	F173-18	F220-18	F275-18
F119-18	F174-18	F221-18	F276-18
F120-18	G28-18	F222-18	F277-18
F121-18	F175-18	F223-18	G50-18
F122-18 Part I	F176-18	F224-18	F278-18
F123-18	G23-18 Part II	F225-18	F279-18
F124-18	F177-18	F226-18	F280-18
F125-18	F178-18	F227-18	F281-18
F126-18	F179-18	F228-18	F282-18
F127-18	F180-18	F229-18	F283-18
F128-18	F181-18	F230-18	F284-18
F129-18	F182-18	F231-18	F285-18
F130-18	F183-18	G52-18	F286-18
F131-18	F184-18	F232-18	F287-18
F132-18	F186-18	F233-18	F288-18
F133-18	F187-18	F234-18	F289-18
F134-18	F188-18	F235-18	F290-18
F135-18	F189-18	F236-18	F291-18
F136-18	F190-18	F237-18	F292-18
F138-18	F191-18	F238-18	F293-18
F139-18	F192-18	F239-18	F294-18
F140-18	F193-18	F240-18	F295-18
F185-18	F194-18	F241-18	F296-18
F141-18	F195-18	F242-18	F297-18 Part I
F142-18	F196-18	F243-18	F297-18 Part II
F143-18	F197-18	F244-18	F298-18
F144-18	F198-18	F7-18	F299-18
F145-18	F199-18	F245-18	F300-18
F146-18	F200-18	F246-18	F301-18
F147-18	F201-18	F247-18	F302-18
F148-18	F202-18	F248-18	F303-18
F149-18	F203-18	F249-18	F304-18
F150-18	G92-18	F5-18	G49-18
F151-18	F204-18	F250-18	G51-18
F152-18	F205-18	F251-18	F305-18
F153-18	F206-18	F252-18	F306-18
F154-18	F207-18	F253-18	F307-18
F155-18	F137-18	F254-18	F308-18
F156-18	F208-18	F256-18	F309-18
F157-18	F209-18	F258-18	F310-18
F158-18	F210-18	F259-18	F311-18
F159-18	F3-18	F260-18	F312-18
G26-18	F211-18	F261-18	F313-18
F160-18	G69-18	F262-18 Part I	F314-18
F161-18	G70-18	F263-18	F315-18
F162-18	F212-18	F264-18	F316-18
F163-18	F213-18	F265-18	F317-18
F164-18	G19-18	F266-18	F318-18
F165-18	G20-18	F268-18	F319-18
F166-18	F214-18	F269-18	F320-18
F167-18	FG22-18	F270-18	F321-18

F322-18
F323-18
F324-18
F325-18
F326-18
F327-18
F328-18

F1-18

IFC: 105.6.3 (New)

Proponent: Bruce Kral, West Metro Fire Protection District, representing West Metro Fire Protection District (bkral@westmetrofire.org)

2018 International Fire Code

Add new text as follows:

105.6.3 Assisted Living. An operational permit is required to operate an assisted living facility.

Reason:

With the increasing complexity of the definitions for I-1 and R-4 occupancies and the associated mobility criteria it is vital to ensure that the requirements for resident mobility, staffing levels and the emergency planning elements of Chapter 4 are complied with in assisted living facilities on an ongoing basis. The elderly population is growing quickly and with the desire for “aging in place” many people are now living in facilities not designed or managed in a way that addresses their declining mobility. Assisted living facilities must be assessed regularly to ensure the features of the building occupancy type and capabilities of the staff are in line with the needs of the residents. An operational permit creates the vehicle for fire departments to evaluate the conditions within the facility and enforce compliance based on the facility’s occupancy type.

Cost Impact

The code change proposal will not increase or decrease the cost of construction .

No increase in construction costs would be created with this proposal as this is related to an operational permit only and is not related to construction.

Internal ID: 1266

F2-18

IFC: 202 (New)

Proponent: Michael O'Brian, Chair, representing FCAC (fcac@iccsafe.org)

2018 International Fire Code

Add new definition as follows:

ACTIVE RF EMITTING DEVICE. Any type of circuit component that requires an AC or DC power source with the ability to electrically control electron flow and/or amplification of RF signal, including but not limited to signal boosters, repeaters, Bi-directional amplifiers, Fiber Distributed Antenna Systems.

DELIVERED AUDIO QUALITY (DAQ). A measure of audio quality over a transmission medium. This metric is often used to quantify the quality of audio heard over a radio system. DAQ levels are defined by the following scale: DAQ 1 = Unusable. Speech is present but not understandable. DAQ 2 = Speech is understandable with considerable effort. Requires frequent repartition due to noise or distortion. DAQ 3 = Speech understandable with slight effort. Requires occasional repetition due to noise or distortion. DAQ 3.4 = Speech understandable without repetition. Some noise or distortion present. DAQ 4 = Speech easily understandable. Little noise or distortion. DAQ 5 = Perfect. No distortion or noise discernible.

RF RADIO FREQUENCY(RF). A measurement representing the oscillation rate of electromagnetic radiation spectrum, or electromagnetic radio waves, from Public Safety frequency bands as specified by the fire code official.

PASSIVE RF EMITTING DEVICE. A device that does not require an external AC or DC source of power for its operation, and does not provide amplification of the RF signal including but not limited to coax, couplers, splitters and passive antennas.

Reason:

This is one of 10 proposals being submitted as a package relating to technical changes proposed for Section 510. While the Fire Code Committee will consider each proposal independently, the intent is for approval of all proposals in this package which have been submitted as a correlated set of companion code change proposals.

This proposal is submitted by the ICC Fire Code Action Committee (FCAC). The FCAC was established by the ICC Board of Directors to pursue opportunities to improve and enhance assigned International Codes with regard to fire safety and hazardous materials in new and existing buildings and facilities and the protection of life and property in wildland urban interface areas. In 2017 the Fire-CAC has held 3 open meetings. In addition, there were numerous conference calls, Regional Work Group and Task Group meetings for the current code development cycle, which included members of the committees as well as any interested parties, to discuss and debate the proposed changes. Related documentation and reports are posted on the FCAC website at: <https://www.iccsafe.org/codes-tech-support/cs/fire-code-action-committee-fcac/>

During training sessions with code officials throughout the US there have been numerous discussions about what these terms as used within the code actually mean. This proposal does not change any of the technical provisions of Section 510 but simply provides definitions to clarify the intent of terms utilized within the code language related to in-building public safety communications.

Cost Impact

The code change proposal will not increase or decrease the cost of construction .

This proposal does not change any of the technical provisions of Section 510 but simply provides definitions to clarify the intent of terms utilized within the code language related to in-building public safety communications. Since it is simply clarification cost will not increase.

Internal ID: 977

F3-18

IFC: 202

Proponent: Richard Kluge, Ericsson Inc., representing Alliance for Telecommunications Industry Solutions (richard.kluge@ericsson.com)

2018 International Fire Code

BATTERY TYPES.

Flow battery. A type of storage battery that includes chemical components dissolved in two different liquids. Ion exchange, which provides the flow of electrical current, occurs through the membrane while both liquids circulate in their respective spaces.

Lead-acid battery. A storage battery that is comprised of lead electrodes immersed in a solution of water and sulphuric acid electrolyte.

Lithium-ion battery. A storage battery with lithium ions serving as the charge carriers of the battery. The electrolyte is a polymer mixture of carbonates with an inorganic salt and can be in a liquid or a gelled polymer form. Lithiated metal oxide is typically a cathode and forms of carbon or graphite typically form the anode.

Nickel-cadmium (Ni-Cd) battery. An alkaline storage battery in which the positive active material is nickel oxide, the negative contains cadmium and the electrolyte is a solution of water and potassium hydroxide.

Preengineered stationary storage battery system. An energy storage system consisting of batteries, a battery management system, components and modules that are produced in a factory, designed to comprise the system when assembled on the job site.

Prepackaged stationary storage battery system. An energy storage system consisting of batteries, a battery management system, components and modules that is factory assembled and shipped as a complete unit for installation at the job site.

Sodium-beta storage battery. A storage battery, also referred to as a Na-beta battery or NBB, which uses a solid beta-alumina electrolyte membrane that selectively allows sodium ion transport between a positive electrode such as metal halide and a negative sodium electrode.

Stationary storage battery. A group of electrochemical cells interconnected to supply a nominal voltage of DC power to a suitably connected electrical load, designed for service in a permanent location.

Reason:

Lead acid batteries need water to operate. Only about 30% of the electrolyte is sulfuric acid. The balance is water.

Nickel Cadmium batteries require water to operate. Only about 30% of the electrolyte is comprised of potassium hydroxide. The balance is water.

Cost Impact

The code change proposal will not increase or decrease the cost of construction .

This change simply adds information to 2 definitions.

Internal ID: 1900

F4-18 Part I

IFC: 202 (New)

Proponent: Dave Frable, U.S. General Services Administration, representing U.S. General Services Administration

THIS IS A 2 PART CODE CHANGE PROPOSAL. PART I WILL BE HEARD THE IFC COMMITTEE, PART II WILL BE HEARD BY THE IBC-FS COMMITTEE. PLEASE SEE THE TENTATIVE HEARING ORDERS FOR THE RESPECTIVE COMMITTEES.

2018 International Fire Code

Add new definition as follows:

LIFE SAFETY SYSTEMS. Systems, devices, and equipment that enhance or facilitates evacuation, smoke control, compartmentation, and/or isolation.

Internal ID: 1861

F4-18 Part II

IBC: 202 (New)

Proponent: Dave Frable, U.S. General Services Administration, representing U.S. General Services Administration

2018 International Building Code

Add new definition as follows:

LIFE SAFETY SYSTEMS. Systems, devices, and equipment that enhance or facilitates evacuation, smoke control, compartmentation, and/or isolation.

Reason:

The intent of this code change proposal is to define the term “life safety system”. The subject term is used in the title of IFC and IBC Chapter 9, Fire Protection and Life Safety Systems and throughout Chapter 9 but is not defined. In addition, the term “fire protection system” is defined; however, “life safety system is not.

Cost Impact

The code change proposal will not increase or decrease the cost of construction .

This is a definition and will not affect the cost of construction and is simply a clarification of intent.

Internal ID: 3486

F5-18

IFC: 202

Proponent: Bob Morgan, Fort Worth Fire Department, representing Fort Worth Fire Department

2018 International Fire Code

Revise as follows:

HIGH-PILED COMBUSTIBLE STORAGE. Storage of combustible materials in closely packed piles or combustible materials on pallets, in racks or on shelves where the top of storage is greater than 12 feet (3658 mm) in height. Where required by the fire code official, high-piled combustible storage also includes certain high-hazard commodities, such as rubber tires, Group A plastics, flammable liquids, idle pallets and similar commodities, where the top of storage is greater than 6 feet (1829 mm) in height. Any Group S occupancy exceeding 12,000 sq. ft. that has a clear height in excess of 14 feet, making it possible to be used for storage in excess of 12 feet, shall be considered to be high-piled storage.

Reason:

We have had this amendment regionally in the North Texas for many years. The primary issue was construction of facilities proposing to not store high-piled, then later Fire Inspections discovered high-piled storage resulting in retroactive requirements to comply with high-piled storage requirements due to the change of use. This became an enforcement nightmare for the subject jurisdiction. Requiring compliance with the high-piled storage provisions up front results in ease of flexibility of use of the building in the future in this regard.

Cost Impact

The code change proposal will increase the cost of construction .

There is a potential to increase the cost of construction by requiring compliance with Chapter 32 for high-piled storage. In excess of 12,000 sq. ft., the occupancy should already require sprinkler protection, but the additional requirements of Chapter 32 would now apply as well as the High-piled storage permit in 105.7.

Internal ID: 920

F6-18

IFC: 202 (New), 302, 302.1

Proponent: Bo Manalo, EcoSmart Inc., representing EcoSmart Inc. (bo@ecosmartfire.com)

2018 International Fire Code

Add new definition as follows:

OPEN FLAME. A flame that is generated by any material or device in a sustained and controlled manner and that is not securely enclosed by non-combustible material, such as a candle that is unenclosed or enclosed in a globe or lantern, or a gas light lantern, but not a flame contained in a furnace or other similar approved device, equipment or system.

Add new text as follows:

SECTION 302 DEFINITIONS

302.1 Definitions.

The following terms are defined in Chapter 2:

BONFIRE.

HI-BOY.

HIGH-VOLTAGE TRANSMISSION LINE.

OPEN BURNING.

OPEN FLAME.

PORTABLE OUTDOOR FIREPLACE.

POWERED INDUSTRIAL TRUCK.

RECREATIONAL FIRE.

SKY LANTERN.

Reason:

Section 308 of the Fire Code shows the provisions for Open Flames but without definition, unlike the other provisions in Section 307 for Open Burning, Recreational Fires, and Portable Outdoor Fireplace (all defined in Chapter 2). This proposal gives consistency and definition to the frequently used term and helps provide better guidance to the user. The definition is derived from the FDNY Fire Code definition of Open Flame.

Cost Impact

The code change proposal will not increase or decrease the cost of construction .

This will not increase the cost of construction or compliance as it is simply a clarification of what constitutes an “open flame.”

Internal ID: 1928

F7-18

IFC: 202

Proponent: Ken Brouillette, representing Seattle Fire Department (ken.brouillette@seattle.gov)

2018 International Fire Code

Revise as follows:

OUTDOOR ASSEMBLY EVENT. ~~An outdoor gathering of persons for any purpose.~~ Private or public event conducted outdoors and having a planned attendance of 500 or more or confines 100 or more attendees by permanent or temporary installations of barriers or fencing. This definition does not include events held at Group R-3 occupancies.

Reason:

The current definition was too broad and by adding a projected occupant load of 500 or more would help to reduce the all encompassing existing definition.

The 500 threshold was chosen as it is the threshold for requiring a crowd manager in 403.12.3. The 100 or more when the attendees are restricted in movement was based on the occupant load necessary for a Place of Assembly permit in the City of Seattle.

Cost Impact

The code change proposal will not increase or decrease the cost of construction .

This proposal is regarding outdoor assemblies and would not require any changes to existing construction or require any new construction to occur.

Internal ID: 1461

F8-18

IFC: 304, 304.4 (New)

Proponent: Matthew Dobson, Vinyl Siding Institute, representing Suburban Exterior Fire Work Group (mdobson@vinylsiding.org); Richard Swan, International Association of Fire Fighters, representing International Association of Fire Fighters (rswan@iaff.org)

2018 International Fire Code

Revise as follows:

SECTION 304 COMBUSTIBLE WASTE AND LANDSCAPING MATERIAL

Add new text as follows:

304.4 Mulch. Combustible landscaping mulch shall not be placed within 3 feet of combustible walls, roofs, or other combustible components of Group R buildings of Type V construction.

Reason:

Over the past code cycles there has been concern over smoker habits, combustible mulch, and the potential hazard they pose with combustion of exterior walls. The Suburban Exterior Fire Work Group, a group of fire service members, UL fire fighter safety institute, and other material stakeholders has been focused on this issue over the past 18 months.

The problem identified is the spread of fire from the exterior into to the unprotected attic space and then spreading quickly to other parts of the building.

The group has taken a 3 prong approach to address the issue:

1. Regulate the human risk by prohibiting smoking near exterior doors.
2. Remove combustible material/mulch from near the outside of combustible wall assemblies.
3. Create a block to slow down any fires that occur in the above described setting.

Over the decade, fire departments in the Washington, DC region have been confronted with structure fires which have demonstrated a consistent pattern of starting on the outside. These fires have the potential for rapid loss of structural integrity and catastrophic collapse before occupants are alerted. As attention has grown locally, it is apparent that this type of fire is becoming common on a national basis.

These fires tend to follow a distinct pattern. These fires start at a low point on the exterior and spread vertically along the exterior wall producing flammable gases, which are readily admitted into the attic area through ventilation soffits. If not cooled, these heated gases accumulate and combust, creating rapidly spreading fire conditions in the attic area, often without occupant awareness. The unchecked fire often results in full roof involvement, creating a dangerous and difficult situation for occupants and fire fighters.

The group examined a number of structure fires which have exhibited the pattern described above. There is agreement over 3 common aspects. First, these fires often result from careless smoking habits. Second, when the smoking materials are not properly disposed of, they often come into contact with combustible materials adjacent to a building and, very commonly, this is mulch. And, last, the combustible exterior wall is a factor in the the growth of these fires into the attic space.

The careless smoker is an impediment to effective fire prevention efforts. The fire service has consistently provided data that shows smoking is the leading cause of fatal fires in the United States. Public fire and life safety efforts have been reasonably effective at communicating the message to not smoke in bed, and various medical organizations have demonstrated the health risk associated with "second hand" smoke. We now see that people are routinely smoking outside, at or near the entrance to a building, which increases the possibility of an accidental ignition of outside combustibles. If one were to chronicle the actions of today's smoker, it would likely show the last action they take when exiting a building is to "light up." When returning inside, they often drop the cigarette near the entrance. Many smokers seem to believe that dropping a match or cigarette onto the ground or into a flower pot is an effective method of extinguishment, however, this behavior often places the smoking material directly into the mulch, initiating the low fire described earlier.

Mulch has become a common exterior decorative material which aids in suppressing weed growth while enhancing a building's curb appeal. However, most mulch is a dead organic material, comprised of chipped wood, tree bark or pine needles. Mulch is most effective when it is maintained in a moist state, however it can dry out very quickly and become a readily ignitable fuel source. Because of its relatively small mass in comparison to its surface area, when ignited, it

will progress and sustain open flame.

The group discussed a method in which to proceed, the interest being to address, in the quickest manner, industrial and social changes which could reduce the possibility of a fire on the outside of a building. Each aspect presents unique challenges for fire prevention efforts:

1. Changing the behavior of the smoker is an ongoing and difficult challenge, especially as social pressures have resulted in regulatory changes to require people to smoke outside of a building. Further development of the “fire safe” cigarette, by way of testing using mulch, could be deemed too costly for the industry, and would have no effect on improper disposal of matches. Thus, the quickest and most practical strategy for this aspect of the problem is to expand public fire and life safety education to focus on the hazards of improper disposal of smoking materials, coupled with enforcement of applicable requirements for regulation of smoking and disposal of products. However, in this age of “information overflow” it is questionable if this would result in widespread behavioral changes for smokers.
2. Regulating the use and placement of mulch, that the study group believes could have the quickest and most significant impact toward reducing the exterior fire problem, while additional strategies to address the other problems noted are pursued.

The use of wood and wood related mulch for building decoration is purely optional. It is not a required construction component under current building codes. Therefore, regulations to curtail its use or require that it be separated from a building’s combustible exterior are reasonable and could be codified on a national basis. On a large scale, the mere action of creating separation of combustible materials has been a wildland fire tactic for years. Several states and local jurisdictions have already employed this theory by either recommending or requiring that wood-based mulch be separated from exterior combustible walls:

1. The Virginia Department of Forestry recommends to “provide a minimum of an 18 inch clearance between landscaping mulch beds and combustible building materials” and to “ensure proper clearance to electric devices, such as decorative lights, by following the manufacturer’s instructions;”
2. In Raleigh, NC, following a disastrous fire in a multi-family building, the city passed a pine straw mulch ordinance that bans the use of pine straw as ground cover within 10 feet of multi-family dwellings. The ordinance exempts 1 and 2-family dwellings, however, the city strongly encourages these homeowners to comply with the pine straw restrictions;
3. The Commonwealth of Massachusetts prohibits the new application of mulch within 18 inches around combustible exteriors of buildings, such as wood or vinyl but not brick or concrete. Residential buildings with six units or less are exempted from this regulation, but it is recommended that all homeowners adopt these safety practices. The regulation applies to all other buildings including commercial properties.
4. Ventura County, CA prohibits mulch and wood chips within the required “defensible space” zone (which ranges from 0’ to 30’ from the exterior of a building).

This small sampling of jurisdictions has produced enough evidence to lead the study group to suggest the possible introduction of a code proposal to require separation, or non-application, of wood-based mulch in proximity to combustible exterior walls.

The proposed protected soffit approach will require a form of blocking outside of exterior doorways and garage doors. These proposed material have been required in North Carolina for over 5 years and are accepted to provide some form of blocking that will slow down the movement of fire from the outside to the attic space, effectively helping to address the issue and allow fire service more time put out the fire.

We think this approach is effective, efficient, and cost effective.

Cost Impact

The code change proposal will not increase or decrease the cost of construction .

This change should not impact the cost of construction as this requirement is addressing only the placement of landscape materials.

Internal ID: 1093

F9-18

IFC: 304.1.3, 304.1.3.1, 903.2.1.4, 903.2.1.5, 903.2.1.5.1, [BE] 1029.1.1, [BE]1029.1.1.1; IBC: [F] 903.2.1.4, [F] 903.2.1.5, [F]903.2.1.5.1, 1029.1.1, 1029.1.1.1

Proponent: Gene Boecker, Code Consultants, Inc., representing Code Consultants, Inc. (geneb@codeconsultants.com)

2018 International Fire Code

304.1.3 Space underneath seats. Spaces underneath grandstand and bleacher seats shall be kept free from combustible and flammable materials. Except where enclosed in not less than 1-hour fire-resistance-rated construction in accordance with the International Building Code.

Revise as follows:

304.1.3.1 Spaces underneath grandstands and bleachers. ~~Spaces~~ Enclosed spaces underneath grandstands and bleachers shall not be occupied ~~or utilized for purposes other than means of egress~~ except where equipped with an *automatic sprinkler system* in accordance with Section 903.2.1.5.1, or separated with fire barriers and horizontal assemblies in accordance with Section 1029.1.1.1.

903.2.1.4 Group A-4. An *automatic sprinkler system* shall be provided throughout stories containing Group A-4 occupancies and throughout all stories from the Group A-4 occupancy to and including the levels of exit discharge serving that occupancy where one of the following conditions exists:

1. The *fire area* exceeds 12,000 square feet (1115 m²).
2. The *fire area* has an *occupant load* of 300 or more.
3. The *fire area* is located on a floor other than a *level of exit discharge* serving such occupancies.

903.2.1.5 Group A-5. An *automatic sprinkler system* shall be provided for all enclosed Group A-5 accessory use areas in excess of 1,000 square feet (93 m²).

903.2.1.5.1 Spaces under grandstands or bleachers. Enclosed spaces under *grandstands* or *bleachers* shall be equipped with an *automatic sprinkler system* in accordance with Section 903.3.1.1 where either of the following exist:

1. The enclosed area is 1,000 square feet (93 m²) or less and is not ~~constructed~~ separated in accordance with Section 1029.1.1.1.
2. The enclosed area exceeds 1,000 square feet (93 m²).

Exception: Toilet rooms and ticket booths complying with Section 1029.1.1.1 are not required to comply with this section.

[BE] 1029.1.1 Bleachers. *Bleachers, grandstands* and *folding and telescopic seating*, that are not building elements, shall comply with ICC 300.

[BE] 1029.1.1.1 Spaces under grandstands and bleachers. Spaces under *grandstands* or *bleachers* shall be separated by *fire barriers* complying with Section 707 of the International Building Code and *horizontal assemblies* complying with Section 711 of the International Building Code with not less than 1-hour fire-resistance-rated construction.

Exceptions:

1. Ticket booths less than 100 square feet (9 m²) in area.
2. Toilet rooms.
3. Other accessory use areas 1,000 square feet (93 m²) or less in area and equipped with an automatic sprinkler system in accordance with Section 903.3.1.1.
4. In Group A-4 where an automatic sprinkler system is not required in accordance with Section 903.2.1.4.

Reason:

F153-16 AM, from FCAC made some revisions for bleachers and grandstands that ended up pointing out some inconsistencies.

Bleachers can be in Group A-4 and A-5 occupancies. The current language is written only for Group A-5. Exception 4 is added to 1029.1.1.1 for consistency with 903.2.1.4.

By changing all the relevant sections to 'enclosed' areas under bleachers there is consistency across all the requirements for under bleachers. It is not the intent to prohibit an open air vomitory system of egress under large bleacher systems. Also, then if the means of egress is open, it does not have to be considered in the sprinkler requirements. If the means of egress is enclosed, it should be included.

Section 1029.1.1.1 currently allows for bathrooms under the grandstands to not be sprinklered. These could be larger than 1,000 sq.ft. so Section 903.2.1.5.1 and 1029.1.1.1 are not aligned.

Cost Impact

The code change proposal will not increase or decrease the cost of construction .

This is a clarification and alignment of requirements. There are no new requirements.

Internal ID: 732

F10-18

IFC: 304.3.2, 304.3.4, 808.1, 808.1.1, 808.1.2, 808.2, Chapter 80

Proponent: William Freer, representing New York State Office of Fire Prevention and Control (wfreer@dhses.ny.gov)

2018 International Fire Code

Revise as follows:

304.3.2 Capacity exceeding 5.33 cubic feet. Containers with a capacity exceeding 5.33 cubic feet (40 gallons) (0.15 m³) shall be provided with lids. Containers and lids shall be constructed of noncombustible materials or of combustible materials with a peak rate of heat release not exceeding 300 kW/m² where tested in accordance with ASTM E1354 at an incident heat flux of 50 kW/m² in the horizontal orientation

Exception: ~~Wastebaskets complying with Section 808.1 or listed and labeled in accordance with FM 6921.~~

304.3.4 Capacity of 1 cubic yard or more. Dumpsters with an individual capacity of 1.0 cubic yard [200 gallons (0.76 m³)] or more shall not be stored in buildings or placed within 5 feet (1524 mm) of combustible walls, openings or combustible roof eave lines unless the dumpsters are constructed of noncombustible materials or of combustible materials with a peak rate of heat release not exceeding 300 kW/m² where tested in accordance with ASTM E1354 at an incident heat flux of 50 kW/m² in the horizontal orientation. orientation or listed and labeled in accordance with FM 6921.

Exceptions:

1. Dumpsters in areas protected by an *approved automatic sprinkler system* installed throughout in accordance with Section 903.3.1.1, 903.3.1.2 or 903.3.1.3.
2. Storage in a structure shall not be prohibited where the structure is of Type I or IIA construction, located not less than 10 feet (3048 mm) from other buildings and used exclusively for dumpster or container storage.

~~808.1.1304.3.5~~ **Wastebaskets and linen containers in Group I-1, I-2 and I-3 occupancies and Group B ambulatory care facilities.** ~~Wastebaskets, Waste and linen containers and other waste containers, including their lids, located in Group I-1, I-2 and I-3 occupancies and Group B ambulatory care facilities shall be constructed of noncombustible materials or of materials that meet a peak rate of heat release not exceeding 300 kW/m² when tested in accordance with ASTM E1354 at an incident heat flux of 50 kW/m² in the horizontal orientation. Metal wastebaskets and other metal orientation or listed and labeled in accordance with FM 6921. Metal waste containers with a capacity of 20 gallons (75.7 L) or more shall be listed in accordance with UL 1315 and shall be provided with a noncombustible lid. Portable containers exceeding 32 gallons (121 L) shall be stored in an area classified as a waste and linen collection room and constructed in accordance with Table 509 of the International Building Code.~~

Exception: Recycling containers complying with Section 808.1.2 are not required to be stored in waste and linen collection rooms.

~~808.1.1304.3.5.1~~ **Capacity density.** The average capacity density of containers located in an individual room or space, other than waste and linen collection rooms, shall not be greater than 0.5 gal/ft² (20.4 L/m²).

~~808.1.2304.3.5.2~~ **Recycling clean waste containers.** Recycling clean waste containers, including their lids, shall not exceed an individual capacity of 96 gallons (363 L).

~~808.2305.3.6~~ **Waste containers with a capacity of 20 gallons or more in Group R-2 college and university dormitories.** Waste containers, including their lids, located in Group R-2 college and university dormitories, and with a capacity of 20 gallons (75.7 L) or more, shall be constructed of noncombustible materials or of materials that meet a peak rate of heat release not exceeding 300 kW/m² when tested in accordance with ASTM E1354 at an incident heat flux of 50 kW/m² in the horizontal orientation. Metal wastebaskets and other metal orientation or listed and labeled in accordance with FM 6921. Metal waste containers with a capacity of 20 gallons (75.7 L) or more shall be listed in accordance with UL 1315 and shall be provided with a noncombustible lid. Portable containers exceeding 32 gallons (121 L) shall be stored in an area classified as a waste and linen collection room constructed in accordance with Table 509 of the International Building Code.

Add new standard(s) follows:

FM

FM Approvals
Headquarters Office 1151 Boston-
Providence Turnpike P.O. Box 9102
Norwood MA 02062

FM 6921- 2014:

Containers for Combustible Waste

Reason:

This code change puts all all of the waste container requirements into the same section and makes it easier on the CEO to enforce. It also eliminates the term wastebasket which is not defined in the code and replaces it with waste container.

This code change also allows an alternative compliance method, using FM 6921. The FM test is a performance based design method, while the current UL test is based on heat release rates.

Cost Impact

The code change proposal will not increase or decrease the cost of construction .

This code change clarifies the requirements of the code and allows for other options for compliance which may decrease the cost of construction.

Analysis: A review of the standard proposed for inclusion in the code, FM 6921-2014 Containers for Combustible Waste, with regard to the ICC criteria for referenced standards (Section 3.6 of CP#28) will be posted on the ICC website on or before April 2, 2018.

Internal ID: 1060

F11-18

IFC: 105.6.15 (New), 202 (New), 308.3.2

Proponent: Ken Brouillette, Seattle Fire Department, representing Seattle Fire Department
(ken.brouillette@seattle.gov)

2018 International Fire Code

Add new text as follows:

105.6.15 Flame effects before an audience. An operational permit is required to use flame effects before an audience in connection with Group A, B or E occupancies, covered malls and outdoor assembly events.

Add new definition as follows:

FLAME EFFECT. The combustion of solids, liquids, or gases to produce thermal, physical, visual, or audible phenomena before an audience.

Revise as follows:

308.3.2 ~~Theatrical performances.~~ Performances before an audience. Where *approved*, open-flames, open-flame devices and flame effects used in conjunction with ~~theatrical performances~~ before an audience are allowed to be used in venues protected by an approved automatic sprinkler systems in accordance with Section 903.3.1.1 and where adequate safety precautions have been taken in accordance with NFPA 160.

Reason:

Flame performances are being conducted throughout the United States. The IFC did not have any direct regulations. This language in this proposal was adopted in the City of Seattle to give guidance to performers and others conducting this activity inside of venues. The additional requirement of only allowing this activity inside of a venue that is protected with an approved automatic fire sprinkler system is just a common sense approach.

Cost Impact

The code change proposal will not increase or decrease the cost of construction .

This proposal will not increase or decrease the cost of construction because it pertains to existing buildings that could be used for the presentation of flame effects before an audience.

Internal ID: 1393

F12-18

IFC: 310.2, 310.2.1 (New), 310.3, 310.6

Proponent: John Williams, Chair, representing Healthcare Committee (AHC@iccsafe.org)

2018 International Fire Code

Revise as follows:

310.2 Prohibited areas. Smoking shall be prohibited where conditions are such as to make smoking a hazard, and in spaces where flammable or combustible materials are stored or handled.

Exception: In Group I-2 occupancies, patients shall be permitted to smoke in designated patient care areas, based on clinical needs of the patient.

Add new text as follows:

310.2.1 Group I-2. In Group I-2 occupancies smoking shall be prohibited in patient care areas, or where oxygen is used, stored or handled.

Revise as follows:

310.3 "No Smoking" signs. The *fire code official* is authorized to order the posting of "No Smoking" signs or the international symbol for no smoking in a conspicuous location in each structure or location in which smoking is prohibited. The content, lettering, size, color and location of required "No Smoking" signs shall be *approved*.

Exception: ~~In Group I-2 occupancies where smoking is prohibited,~~ "No Smoking" signs are not required in interior locations of the facility where signs are displayed at all major entrances into the facility.

310.6 Ash trays. Where smoking is permitted, suitable noncombustible ash trays or match receivers shall be provided on each table and at other appropriate locations. In Group I-2 occupancies, non-combustible, metal containers with self-closing covers, shall be provide in areas where smoking is permitted.

Reason:

The signage exception from the 2015 cycle is moved to a dedicated paragraph for I-2 occupancies. Certain allowances for smoking by patients or residents are added to the K-Tag, so breaking out the occupancy into its own paragraph makes sense. Psychiatric allowances are also needed to manage smoking, particularly among behavioral health addiction patients. Use of the term "designated" enables the facility to establish specific, limited areas for this function, and enables the care provider to put the patient in the correct environment.

This proposal is submitted by the ICC Committee on Healthcare (CHC). The CHC was established by the ICC Board to evaluate and assess contemporary code issues relating to healthcare facilities. This is a joint effort between ICC and the American Society for Healthcare Engineering (ASHE), a subsidiary of the American Hospital Association, to eliminate duplication and conflicts in healthcare regulation. In 2017 the CHC held 2 open meetings and numerous conference calls, which included members of the committees as well as any interested parties, to discuss and debate the proposed changes. Information on the CHC, including: meeting agendas; minutes; reports; resource documents; presentations; and all other materials developed in conjunction with the CHC effort can be downloaded from the CHC website at: <https://www.iccsafe.org/codes-tech-support/cs/icc-committee-on-healthcare/>.

Cost Impact

The code change proposal will not increase or decrease the cost of construction .

This is an operational requirement only, with no technical changes for construction.

Internal ID: 691

F13-18

IFC: 310.9 (New)

Proponent: Matthew Dobson, Vinyl Siding Institute, representing Suburban Exterior Fire Work Group (mdobson@vinylsiding.org); Richard Swan, representing International Association of Fire Fighters (rswan@iaff.org)

2018 International Fire Code

Add new text as follows:

310.9 Group R. Smoking shall be prohibited within 25 feet of any exterior door of Group R buildings of Type V construction.

Reason:

Over the past code cycles there has been concern over smoker habits, combustible mulch, and the potential hazard they pose with combustion of exterior walls. The Suburban Exterior Fire Work Group, a group of fire service members, UL fire fighter safety institute, and other material stakeholders has been focused on this issue over the past 18 months.

The problem identified is the spread of fire from the exterior into to the unprotected attic space and then spreading quickly to other parts of the building.

The group has taken a 3 prong approach to address the issue:

Regulate the human risk by prohibiting smoking near exterior doors.

Remove combustible material/mulch from near the outside of combustible wall assemblies.

Create a block to slow down any fires that occur in the above described setting.

The proposed protected soffit approach, contained in a proposal for the IBC, will require a form of blocking outside of exterior doorways and garage doors in the soffit area. These proposed material have been required in North Carolina for over 5 years and are accepted to provide some form of blocking that will slow down the movement of fire from the outside to the attic space, effectively helping to address the issue and allow fire service more time put out the fire. Testing on these protected soffits are currently underway to show the effectiveness of these assemblies both vented and unvented.

Over the decade, fire departments in the Washington, DC region have been confronted with structure fires which have demonstrated a consistent pattern of starting on the outside. These fires have the potential for rapid loss of structural integrity and catastrophic collapse before occupants are alerted. As attention has grown locally, it is apparent that this type of fire is becoming common on a national basis.

These fires tend to follow a distinct pattern. These fires start at a low point on the exterior and spread vertically along the exterior wall producing flammable gases, which are readily admitted into the attic area through ventilation soffits. If not cooled, these heated gases accumulate and combust, creating rapidly spreading fire conditions in the attic area, often without occupant awareness. The unchecked fire often results in full roof involvement, creating a dangerous and difficult situation for occupants and fire fighters.

The group examined a number of structure fires which have exhibited the pattern described above. There is agreement over 3 common aspects. First, these fires often result from careless smoking habits. Second, when the smoking materials are not properly disposed of, they often come into contact with combustible materials adjacent to a building and, very commonly, this is mulch. And, last, the combustible exterior wall is a factor in the the growth of these fires into the attic space.

The careless smoker is an impediment to effective fire prevention efforts. The fire service has consistently provided data that shows smoking is the leading cause of fatal fires in the United States. Public fire and life safety efforts have been reasonably effective at communicating the message to not smoke in bed, and various medical organizations have demonstrated the health risk associated with "second hand" smoke. We now see that people are routinely smoking outside, at or near the entrance to a building, which increases the possibility of an accidental ignition of outside combustibles. If one were to chronicle the actions of today's smoker, it would likely show the last action they take when exiting a building is to "light up." When returning inside, they often drop the cigarette near the entrance. Many smokers seem to believe that dropping a match or cigarette onto the ground or into a flower pot is an effective method of extinguishment, however, this behavior often places the smoking material directly into the mulch, initiating the low fire described earlier.

Mulch has become a common exterior decorative material which aids in suppressing weed growth while enhancing a building's curb appeal. However, most mulch is a dead organic material, comprised of chipped wood, tree bark or pine needles. Mulch is most effective when it is maintained in a moist state, however it can dry out very quickly and become a readily ignitable fuel source. Because of its relatively small mass in comparison to its surface area, when ignited, it

will progress and sustain open flame.

The group discussed a method in which to proceed, the interest being to address, in the quickest manner, industrial and social changes which could reduce the possibility of a fire on the outside of a building. Each aspect presents unique challenges for fire prevention efforts:

1. Changing the behavior of the smoker is an ongoing and difficult challenge, especially as social pressures have resulted in regulatory changes to require people to smoke outside of a building. Further development of the “fire safe” cigarette, by way of testing using mulch, could be deemed too costly for the industry, and would have no effect on improper disposal of matches. Thus, the quickest and most practical strategy for this aspect of the problem is to expand public fire and life safety education to focus on the hazards of improper disposal of smoking materials, coupled with enforcement of applicable requirements for regulation of smoking and disposal of products. However, in this age of “information overflow” it is questionable if this would result in widespread behavioral changes for smokers;
2. Regulating the use and placement of mulch, that the study group believes could have the quickest and most significant impact toward reducing the exterior fire problem, while additional strategies to address the other problems noted are pursued.

The use of wood and wood related mulch for building decoration is purely optional. It is not a required construction component under current building codes. Therefore, regulations to curtail its use or require that it be separated from a building’s combustible exterior are reasonable and could be codified on a national basis. On a large scale, the mere action of creating separation of combustible materials has been a wildland fire tactic for years. Several states and local jurisdictions have already employed this theory by either recommending or requiring that wood-based mulch be separated from exterior combustible walls:

1. The Virginia Department of Forestry recommends to “provide a minimum of an 18 inch clearance between landscaping mulch beds and combustible building materials” and to “ensure proper clearance to electric devices, such as decorative lights, by following the manufacturer’s instructions;”
2. In Raleigh, NC, following a disastrous fire in a multi-family building, the city passed a pine straw mulch ordinance that bans the use of pine straw as ground cover within 10 feet of multi-family dwellings. The ordinance exempts 1 and 2-family dwellings, however, the city strongly encourages these homeowners to comply with the pine straw restrictions;
3. The Commonwealth of Massachusetts prohibits the new application of mulch within 18 inches around combustible exteriors of buildings, such as wood or vinyl but not brick or concrete. Residential buildings with six units or less are exempted from this regulation, but it is recommended that all homeowners adopt these safety practices. The regulation applies to all other buildings including commercial properties.
4. Ventura County, CA prohibits mulch and wood chips within the required “defensible space” zone (which ranges from 0’ to 30’ from the exterior of a building).

This small sampling of jurisdictions has produced enough evidence for a code proposal to require separation, or non-application, of wood-based mulch in proximity to combustible exterior walls.

We think this approach is effective, efficient, and cost effective.

Cost Impact

The code change proposal will not increase or decrease the cost of construction .

This change is intended to modify human behavior and will not impact the cost of construction.

Internal ID: 1099

F14-18 Part I

IFC: 311.2.2, 403.11.1.2, [BE]1010.3.2;

IBC: [F]428.3.9, 506.2.2.1, 506.2.4.1, 1705.12.6, 2603.3, 2606.7.4, 3104.5.3

IEBC: 1203.4

Proponent: Jeffrey Hugo, representing National Fire Sprinkler Association (hugo@nfsa.org)

THIS IS A 2 PART CODE CHANGE PROPOSAL. PART I WILL BE HEARD BY THE IFC COMMITTEE. PART II WILL BE HEARD BY THE IRC-PLUMBING COMMITTEE. SEE THE TENTATIVE HEARING ORDERS FOR THESE COMMITTEES.

2018 International Fire Code

Add new text as follows:

311.2.2 Fire protection. Fire alarm, automatic sprinkler systems and stand-pipe systems shall be maintained in an operable condition at all times.

Exceptions:

1. Where the premises have been cleared of all combustible materials and debris and, in the opinion of the *fire code official*, the type of construction, *fire separation distance* and security of the premises do not create a fire hazard.
2. Where *approved* by the *fire code official*, buildings that will not be heated and where *fire protection systems* will be exposed to freezing temperatures, fire alarm and automatic sprinkler systems are permitted to be placed out of service and standpipes are permitted to be maintained as dry systems (without an automatic water supply), provided that the building does not have contents or storage, and windows, doors and other openings are secured to prohibit entry by unauthorized persons.
3. Where *approved* by the *fire code official*, fire alarm and automatic sprinkler systems are permitted to be placed out of service in seasonally occupied buildings: that will not be heated; where fire protection systems will be exposed to freezing temperatures; where *fire areas* do not exceed 12,000 square feet (1115 m²); and that do not store motor vehicles or hazardous materials.

403.11.1.2 Lease plan. In addition to the requirements of Section 404.2.2, a lease plan that includes the following information shall be prepared for each covered and open mall building:

1. Each occupancy, including identification of tenant.
2. Exits from each tenant space.
3. Fire protection features, including the following:
 - 3.1. Fire department connections.
 - 3.2. Fire command center.
 - 3.3. Smoke management system controls.
 - 3.4. Elevators, elevator machine rooms and controls.
 - 3.5. Hose valve outlets.
 - 3.6. Sprinkler and standpipe control valves.
 - 3.7. Automatic Areas protected with automatic sprinkler systems and automatic fire-extinguishing system areas systems.
 - 3.8. Automatic fire detector zones.
 - 3.9. Fire ~~barriers-walls~~, fire barriers, fire partitions

[BE] 1010.3.2 Security access turnstiles. Security access turnstiles that inhibit travel in the direction of egress utilizing a physical barrier shall be permitted to be considered as a component of the means of egress, provided that all of the following criteria are met:

1. The building is protected throughout by an ~~approved, supervised~~ automatic sprinkler system in accordance with Section 903.3.1.1.

2. Each security access turnstile lane configuration has a minimum clear passage width of 22 inches (559 mm).
3. Any security access turnstile lane configuration providing a clear passage width of less than 32 inches (810 mm) shall be credited with a maximum egress capacity of 50 persons.
4. Any security access turnstile lane configuration providing a clear passage width of 32 inches (810 mm) or more shall be credited with a maximum egress capacity as calculated in accordance with Section 1005.
5. Each secured physical barrier shall automatically retract or swing to an unobstructed open position in the direction of egress, under each of the following conditions:
 - 5.1. Upon loss of power to the turnstile or any part of the access control system that secures the physical barrier.
 - 5.2. Upon actuation of a clearly identified manual release device with ready access that results in direct interruption of power to each secured physical barrier, after which such barriers remain in the open position for not less than 30 seconds. The manual release device shall be positioned at one of the following locations:
 - 5.2.1. On the egress side of each security access turnstile lane.
 - 5.2.2. At an approved location where it can be actuated by an employee assigned to the area at all times that the building is occupied.
 - 5.3. Upon actuation of the building fire alarm system, if provided, after which the physical barrier remains in the open position until the fire alarm system is manually reset.

Exception: Actuation of a manual fire alarm box.
 - 5.4. Upon actuation of the building automatic sprinkler system or fire detection system, after which the physical barrier remains in the open position until the fire alarm system is manually reset.

2018 International Building Code

[F] 428.3.9 Automatic fire-extinguishing sprinkler systems. Buildings containing laboratory suites shall be equipped throughout with an ~~approved~~ *approved automatic sprinkler system* in accordance with Section 903.3.1.1.

506.2.2.1 Group H-2 or H-3 mixed occupancies. For a building containing Group H-2 or H-3 occupancies, the allowable area shall be determined in accordance with Section 508.4.2, with the automatic sprinkler system increase applicable only to the portions of the building not classified as Group H-2 or H-3.

506.2.4.1 Group H-2 or H-3 mixed occupancies. For a building containing Group H-2 or H-3 occupancies, the allowable area shall be determined in accordance with Section 508.4.2, with the automatic sprinkler system increase applicable only to the portions of the building not classified as Group H-2 or H-3.

1705.12.6 Plumbing, mechanical and electrical components. Periodic special inspection of plumbing, mechanical and electrical components shall be required for the following:

1. Anchorage of electrical equipment for emergency and standby power systems in structures assigned to *Seismic Design Category C, D, E or F*.
2. Anchorage of other electrical equipment in structures assigned to *Seismic Design Category E or F*.
3. Installation and anchorage of piping systems designed to carry hazardous materials and their associated mechanical units in structures assigned to *Seismic Design Category C, D, E or F*.
4. Installation and anchorage of ductwork designed to carry hazardous materials in structures assigned to *Seismic Design Category C, D, E or F*.
5. Installation and anchorage of vibration isolation systems in structures assigned to *Seismic Design Category C, D, E or F* where the *approved construction documents* require a nominal clearance of $\frac{1}{4}$ inch (6.4 mm) or less between the equipment support frame and restraint.
6. Installation of mechanical and electrical equipment, including duct work, piping systems and their structural supports, where automatic ~~fire~~-sprinkler systems are installed in structures assigned to *Seismic Design Category C, D, E or F* to verify one of the following:
 - 6.1. Minimum clearances have been provided as required by Section 13.2.3 ASCE/SEI 7.

- 6.2. A nominal clearance of not less than 3 inches (76 mm) has been provided between ~~fire protection~~ automatic sprinkler system drops and sprigs and: structural members not used collectively or independently to support the sprinklers; equipment attached to the building structure; and other systems' piping.

Where flexible sprinkler hose fittings are used, special inspection of minimum clearances is not required.

2603.3 Surface-burning characteristics. Unless otherwise indicated in this section, foam plastic insulation and foam plastic cores of manufactured assemblies shall have a flame spread index of not more than 75 and a smoke-developed index of not more than 450 where tested in the maximum thickness intended for use in accordance with ASTM E84 or UL 723. Loose fill-type foam plastic insulation shall be tested as board stock for the flame spread and smoke-developed indices.

Exceptions:

1. Smoke-developed index for interior *trim* as provided for in Section 2604.2.
2. In cold storage buildings, ice plants, food plants, food processing rooms and similar areas, foam plastic insulation where tested in a thickness of 4 inches (102 mm) shall be permitted in a thickness up to 10 inches (254 mm) where the building is equipped throughout with an automatic ~~fire~~ sprinkler system in accordance with Section 903.3.1.1. The approved *automatic sprinkler system* shall be provided in both the room and that part of the building in which the room is located.
3. Foam plastic insulation that is a part of a Class A, B or C roof-covering assembly provided that the assembly with the foam plastic insulation satisfactorily passes NFPA 276 or UL 1256. The smoke-developed index shall not be limited for roof applications.
4. Foam plastic insulation greater than 4 inches (102 mm) in thickness shall have a maximum flame spread index of 75 and a smoke-developed index of 450 where tested at a minimum thickness of 4 inches (102 mm), provided that the end use is approved in accordance with Section 2603.9 using the maximum thickness and density intended for use.
5. Flame spread and smoke-developed indices for foam plastic interior signs in *covered and open mall buildings* provided that the signs comply with Section 402.6.4.

3104.5.3 Open sides on walkway. Where the distance between the connected buildings is more than 10 feet (3048 mm), the walls at the intersection of the *pedestrian walkway* and each building need not be fire-resistance rated provided that both sidewalls of the *pedestrian walkway* are not less than 50 percent open with the open area uniformly distributed to prevent the accumulation of smoke and *toxic* gases. The roof of the walkway shall be located not more than 40 feet (12 160 mm) above *grade plane*, and the walkway shall only be permitted to connect to the third or lower story of each building.

Exception: Where the *pedestrian walkway* is protected with a ~~an~~ automatic sprinkler system in accordance with Section 903.3.1.1, the roof of the walkway shall be located not more than 55 feet (16 764 mm) above *grade plane* and the walkway shall only be permitted to connect to the fifth or lower story of each building.

2606.7.4 ~~Fire suppression~~ Automatic sprinkler system. In buildings that are equipped throughout with an *automatic sprinkler system* in accordance with Section 903.3.1.1, plastic light-diffusing systems shall be protected both above and below unless the sprinkler system has been specifically approved for installation only above the light-diffusing system. Areas of light-diffusing systems that are protected in accordance with this section shall not be limited.

2018 International Existing Building Code

1203.4 Transoms. In ~~fully sprinklered~~ buildings with automatic sprinkler systems of Group R-1, R-2 or R-3 occupancy, existing transoms in corridors and other fire-resistance-rated walls may be maintained if fixed in the closed position. A sprinkler shall be installed on each side of the transom.

F14-18 Part II

IRC: R101.2, R302.2.2, R313, R313.1, R313.1.1, R313.2, R313.2.1, R325.3, TABLE P2902.3, P2902.5.4.1, P2902.5.4, P2904.1

IPC: TABLE 608.1, 608.17.4, 608.17.4.1

Proponent: Jeffrey Hugo, representing National Fire Sprinkler Association (hugo@nfsa.org)

2018 International Residential Code

Revise as follows:

R101.2 Scope. The provisions of this code shall apply to the construction, *alteration*, movement, enlargement, replacement, repair, *equipment*, use and occupancy, location, removal and demolition of detached one- and two-family dwellings and *townhouses* not more than three stories above *grade plane* in height with a separate means of egress and their *accessory structures* not more than three stories above *grade plane* in height.

Exception: The following shall be permitted to be constructed in accordance with this code where provided with a ~~residential fire~~ an automatic sprinkler system complying with Section P2904:

1. Live/work units located in *townhouses* and complying with the requirements of Section 419 of the International Building Code.
2. Owner-occupied lodging houses with five or fewer guestrooms.
3. A care facility with five or fewer persons receiving custodial care within a dwelling unit.
4. A care facility with five or fewer persons receiving medical care within a dwelling unit.
5. A care facility for five or fewer persons receiving care that are within a single-family dwelling.

R302.2.2 Common walls. Common walls separating *townhouses* shall be assigned a fire-resistance rating in accordance with Item 1 or 2. The common wall shared by two *townhouses* shall be constructed without plumbing or mechanical equipment, ducts or vents in the cavity of the common wall. The wall shall be rated for fire exposure from both sides and shall extend to and be tight against exterior walls and the underside of the roof sheathing. Electrical installations shall be in accordance with Chapters 34 through 43. Penetrations of the membrane of common walls for electrical outlet boxes shall be in accordance with Section R302.4.

1. Where a ~~fire~~ an automatic sprinkler system in accordance with Section P2904 is provided, the common wall shall be not less than a 1-hour fire-resistance-rated wall assembly tested in accordance with ASTM E119, UL 263 or Section 703.3 of the International Building Code.
2. Where a ~~fire~~ an automatic sprinkler system in accordance with Section P2904 is not provided, the common wall shall be not less than a 2-hour fire-resistance-rated wall assembly tested in accordance with ASTM E119, UL 263 or Section 703.3 of the International Building Code.

SECTION R313 AUTOMATIC FIRE-SPRINKLER SYSTEMS

R313.1 Townhouse automatic fire sprinkler systems. An automatic ~~residential fire~~ sprinkler system shall be installed in *townhouses*.

Exception: An automatic ~~residential fire~~ sprinkler system shall not be required where *additions* or *alterations* are made to existing *townhouses* that do not have an automatic ~~residential fire~~ sprinkler system installed.

R313.1.1 Design and installation. Automatic ~~residential fire~~ sprinkler systems for *townhouses* shall be designed and installed in accordance with Section P2904 or NFPA 13D.

R313.2 One- and two-family dwellings automatic fire sprinkler systems. An automatic ~~residential fire~~ sprinkler system shall be installed in one- and two-family *dwellings*.

Exception: An automatic ~~residential fire~~ sprinkler system shall not be required for *additions* or *alterations* to existing buildings that are not already provided with an automatic ~~residential~~ sprinkler system.

R313.2.1 Design and installation. Automatic ~~residential fire~~ sprinkler systems shall be designed and installed in accordance with Section P2904 or NFPA 13D.

R325.3 Area limitation. The aggregate area of a mezzanine or mezzanines shall be not greater than one-third of the floor area of the room or space in which they are located. The enclosed portion of a room shall not be included in a

determination of the floor area of the room in which the *mezzanine* is located.

Exception: The aggregate area of a mezzanine located within a dwelling unit equipped with ~~a fire~~ an automatic sprinkler system in accordance with Section P2904 shall not be greater than one-half of the floor area of the room, provided that the mezzanine meets all of the following requirements:

1. Except for enclosed closets and bathrooms, the mezzanine is open to the room in which such mezzanine is located.
2. The opening to the room is unobstructed except for walls not more than 42 inches (1067 mm) in height, columns and posts.
3. The exceptions to Section R325.5 are not applied.

**TABLE P2902.3
APPLICATION FOR BACKFLOW PREVENTERS**

DEVICE	DEGREE OF HAZARD^a	APPLICATION^b	APPLICABLE STANDARDS
Backflow Prevention Assemblies			
Double-check backflow prevention assembly and double-check fire protection backflow prevention assembly	Low hazard	Backpressure or back siphonage Sizes $\frac{3}{8}$ " - 16"	ASSE 1015, AWWA C510, CSA B64.5, CSA B64.5.1
Double-check detector fire protection backflow prevention assemblies	Low hazard	Backpressure or back siphonage Sizes 2" - 16"	ASSE 1048
Pressure vacuum breaker assembly	High or low hazard	Back siphonage only Sizes $\frac{1}{2}$ " - 2"	ASSE 1020, CSA B64.1.2
Reduced pressure principle backflow prevention assembly and reduced pressure principle fire protection backflow prevention assembly	High or low hazard	Backpressure or back siphonage Sizes $\frac{3}{8}$ " - 16"	ASSE 1013, AWWA C511, CSA B64.4, CSA B64.4.1
Reduced pressure detector fire protection backflow prevention assemblies	o	Back siphonage or backpressure (Automatic fire-sprinkler systems)	ASSE 1047
Spill-resistant vacuum breaker	High or low hazard	Back siphonage only Sizes $\frac{1}{4}$ " - 2"	ASSE 1056, CSA B64.1.3
Backflow Preventer Plumbing Devices			
Anti siphon-type fill valves for gravity water closet flush tanks	High hazard	Back siphonage only	ASSE 1002/ASME A112.1002/CSA B125.12, CSA B125.3
Backflow preventer with intermediate atmospheric vents	Low hazard	Backpressure or back siphonage Sizes $\frac{1}{4}$ " - $\frac{3}{8}$ "	ASSE 1012, CSA B64.3
Dual-check-valve-type backflow preventers	Low hazard	Backpressure or back siphonage Sizes $\frac{1}{4}$ " - 1"	ASSE 1024, CSA B64.6
Hose-connection backflow preventer	High or low hazard	Low head backpressure, rated working pressure backpressure or back siphonage Sizes $\frac{1}{2}$ " - 1"	ASSE 1052, CSA B64.2.1.1
Hose-connection vacuum breaker	High or low hazard	Low head backpressure or back siphonage Sizes $\frac{1}{2}$ ", $\frac{3}{4}$ ", 1"	ASSE 1011, CSA B64.2, CSA B64.2.1
Laboratory faucet	High or low hazard	Low head backpressure	ASSE 1035, CSA B64.7

backflow preventer		and backsiphonage	
Pipe-applied atmospheric-type vacuum breaker	High or low hazard	Backsiphonage only Sizes 1/4" - 4"	ASSE 1001, CSA B64.1.1
Vacuum breaker wall hydrants, frost-resistant, automatic-draining type	High or low hazard	Low head backpressure or backsiphonage Sizes 3/4" - 1"	ASSE 1019, CSA B64.2.2
Other Means Or Methods			
Air gap	High or low hazard	Backsiphonage only	ASME A112.1.2
Air gap fittings for use with plumbing fixtures, appliances and appurtenances	High or low hazard	Backsiphonage or backpressure	ASME A112.1.3

For SI: 1 inch = 25.4 mm.

- a. Low hazard—See Pollution (Section R202).
- b. High hazard—See Contamination (Section R202).

P2902.5.4.1 Additives or nonpotable source. Where systems contain chemical additives or antifreeze, or where systems are connected to a nonpotable secondary water supply, the potable water supply shall be protected against backflow by a reduced pressure principle backflow prevention assembly or a reduced pressure principle fire protection backflow prevention assembly. Where chemical additives or antifreeze is added to only a portion of an automatic fire sprinkler system or standpipe system, the reduced pressure principle fire protection backflow preventer shall be permitted to be located so as to isolate that portion of the system.

P2902.5.4 Connections to automatic fire sprinkler systems. The potable water supply to automatic fire sprinkler systems shall be protected against backflow by a double-check backflow prevention assembly, a double-check fire protection backflow prevention assembly, a reduced pressure principle backflow prevention assembly or a reduced pressure principle fire protection backflow prevention assembly.

Exception: Where sprinkler systems are installed in accordance with Section P2904.1, backflow protection for the water supply system shall not be required.

P2904.1 General. The design and installation of residential fire automatic sprinkler systems shall be in accordance with NFPA 13D or Section P2904, which shall be considered to be equivalent to NFPA 13D. Partial residential sprinkler systems shall be permitted to be installed only in buildings not required to be equipped with a residential sprinkler system. Section P2904 shall apply to stand-alone and multipurpose wet-pipe sprinkler systems that do not include the use of antifreeze. A multipurpose fire sprinkler system shall provide domestic water to both fire sprinklers and plumbing fixtures. A stand-alone sprinkler system shall be separate and independent from the water distribution system. A backflow preventer shall not be required to separate a sprinkler system from the water distribution system, provided that the sprinkler system complies with all of the following:

1. The system complies with NFPA 13D or Section P2904.
2. The piping material complies with Section P2906.
3. The system does not contain antifreeze.
4. The system does not have a fire department connection.

2018 International Plumbing Code

**TABLE 608.1
APPLICATION OF BACKFLOW PREVENTERS**

DEVICE	DEGREE OF HAZARD^a	APPLICATION^b	APPLICABLE STANDARDS
Backflow prevention assemblies:			
Double check backflow prevention assembly and double check fire protection backflow prevention assembly	Low hazard	Backpressure or backsiphonage Sizes 3/8" - 16"	ASSE 1015, AWWA C510, CSA B64.5, CSA B64.5.1
Double check detector fire protection backflow prevention assemblies	Low hazard	Backpressure or backsiphonage Sizes 2" - 16"	ASSE 1048
Pressure vacuum breaker assembly	High or low hazard	Backsiphonage only Sizes 1/2" - 2"	ASSE 1020, CSA B64.1.2
Reduced pressure principle backflow prevention assembly and reduced pressure principle fire protection backflow assembly	High or low hazard	Backpressure or backsiphonage Sizes 3/8" - 16"	ASSE 1013, AWWA C511, CSA B64.4, CSA B64.4.1
Reduced pressure detector fire protection backflow prevention assemblies	High or low hazard	Backsiphonage or backpressure (automatic fire sprinkler systems)	ASSE 1047
Spill-resistant vacuum breaker assembly	High or low hazard	Backsiphonage only Sizes 1/4" - 2"	ASSE 1056; CSA B64.1.3
Backflow preventer plumbing devices:			
Antisiphon-type fill valves for gravity water closet flush tanks	High hazard	Backsiphonage only	ASSE 1002/ASME A112.1002/CSA B125.12, CSA B125.3
Backflow preventer for carbonated beverage machines	Low hazard	Backpressure or backsiphonage Sizes 1/4" - 3/8"	ASSE 1022
Backflow preventer with intermediate atmospheric vents	Low hazard	Backpressure or backsiphonage Sizes 1/4" - 3/4"	ASSE 1012, CSA B64.3
Dual-check-valve-type backflow preventer	Low hazard	Backpressure or backsiphonage Sizes 1/4" - 1"	ASSE 1024, CSA B64.6
Hose connection backflow preventer	High or low hazard	Low head backpressure, rated working pressure, backpressure or backsiphonage Sizes 1/2" - 1"	ASME A112.21.3, ASSE 1052, CSA B64.2.1.1
Hose connection vacuum breaker	High or low hazard	Low head backpressure or backsiphonage Sizes 1/2", 3/4", 1"	ASME A112.21.3, ASSE 1011, CSA B64.2, CSA B64.2.1
Laboratory faucet backflow preventer	High or low hazard	Low head backpressure and backsiphonage	ASSE 1035, CSA B64.7
Pipe-applied atmospheric-type vacuum breaker	High or low hazard	Backsiphonage only Sizes 1/4" - 4"	ASSE 1001, CSA B64.1.1
Vacuum breaker wall hydrants, frost-resistant, automatic-draining-type	High or low hazard	Low head backpressure or backsiphonage Sizes 3/4", 1"	ASME A112.21.3, ASSE 1019, CSA B64.2.2
Other means or methods:			
Air gap	High or low hazard	Backsiphonage or backpressure	ASME A112.1.2
Air gap fittings for use with plumbing fixtures, appliances and appurtenances	High or low hazard	Backsiphonage or backpressure	ASME A112.1.3
Barometric loop	High or low hazard	Backsiphonage only	(See Section 608.14.4)

For SI: 1 inch = 25.4 mm.

- a. Low hazard—See Pollution (Section 202).
- b. High hazard—See Contamination (Section 202).

608.17.4 Connections to automatic fire-sprinkler systems and standpipe systems. The potable water supply to automatic fire-sprinkler systems and standpipe systems shall be protected against backflow by a double check backflow prevention assembly, a double check fire protection backflow prevention assembly or a reduced pressure principle fire protection backflow prevention assembly.

Exceptions:

1. Where systems are installed as a portion of the water distribution system in accordance with the requirements of this code and are not provided with a fire department connection, isolation of the water supply system shall not be required.
2. Isolation of the water distribution system is not required for deluge, preaction or dry pipe systems.

608.17.4.1 Additives or nonpotable source. Where systems under continuous pressure contain chemical additives or antifreeze, or where systems are connected to a nonpotable secondary water supply, the potable water supply shall be protected against backflow by a reduced pressure principle backflow prevention assembly or a reduced pressure principle fire protection backflow prevention assembly. Where chemical additives or antifreeze are added to only a portion of an automatic fire-sprinkler system or standpipe system, the reduced pressure principle backflow prevention assembly or the reduced pressure principle fire protection backflow prevention assembly shall be permitted to be located so as to isolate that portion of the system. Where systems are not under continuous pressure, the potable water supply shall be protected against backflow by an air gap or an atmospheric vacuum breaker conforming to ASSE 1001 or CSA B64.1.1.

Reason:

Across the I codes there are varying ways to describe an automatic sprinkler system. This proposal correlates several of the I codes to use the defined term of automatic sprinkler system. This allows for a better understanding of the term and application. Other proposals have been submitted to make several sprinkler and fire protection correlations and improvements.

Each section noted in this proposal has been changed to clarify what type of system is installed. In many cases, it is a simple deletion of the word "fire" or an added "automatic" and changes are to refer to the italicized term of automatic sprinkler system as is defined. Some sections are technical changes to reflect the intent of the code, for example the term "suppression" is used when clearly a sprinkler system is meant. Some areas a suppression and sprinkler system are meant for the fire protection.

In the IRC, several "residential" terms are removed and "automatic" inserted. The IRC, just as the other codes, use multiple ways to require the same system. It is appropriate to use the same italicized defined term of automatic sprinkler system.

Cost Impact

The code change proposal will not increase or decrease the cost of construction .

Correlation

Internal ID: 3514

F15-18

IFC: 314.4

Proponent: Stephen DiGiovanni, Clark County, representing self (sdigiovanni@clarkcountynv.gov)

2018 International Fire Code

Revise as follows:

314.4 Vehicles. Liquid-fueled or gaseous-fueled vehicles, aircraft, boats or other motorcraft shall not be located indoors except as follows:

1. The engine starting system is made inoperable or batteries are disconnected except where the *fire code official* requires that the batteries remain connected to maintain safety features.
2. Fuel in fuel tanks does not exceed one-quarter tank or 5 gallons (19 L) (whichever is least).
3. Fuel tanks and fill openings are closed and sealed to prevent tampering.
4. Vehicles, aircraft, boats or other motorcraft equipment are not fueled or defueled within the building.

Reason:

There are two instances of past experience that have driven this code change in Southern Nevada. First, there are temporary displays of aircraft that have occurred, and the proposal intends to ensure that these aircraft are defueled prior to being located indoors for the purpose of display. Second, there are conventions that are almost entirely to show off accessories in vehicles, which require electrical power from the car battery. By allowing the battery to remain connected, while disabling the starting system, the accessories can be displayed, while mitigating the hazard of running vehicles in an assembly space.

Cost Impact

The code change proposal will not increase or decrease the cost of construction .

This proposal does not address building construction. It may cause a complication (which may require added expenses) for anyone that previously displayed aircraft indoors without following these requirements. With respect to the part about the engine starting system, that is only an option that is being provided, so there is no required increase in cost due to that change.

Internal ID: 937

F16-18

IFC: 315.1, 315.1.1 (New)

Proponent: Marcelo Hirschler, GBH International, representing GBH International (gbhint@aol.com)

2018 International Fire Code

Revise as follows:

315.1 General. Storage shall be in accordance with Sections 315.2 through 315.6. Outdoor pallet storage shall be in accordance with Sections 315.2 and 315.7.

~~**Exception:** Wood and wood composite pallets stored outdoors at pallet manufacturing and recycling facilities and complying with Section 2810.~~

Add new text as follows:

315.1.1 Outdoor storage. When stored outdoors, at pallet manufacturing and recycling facilities, plastic and plastic composite pallets listed and labeled in accordance with FM 4996, and wood and wood composite pallets, shall be permitted to comply with Section 2810.

Reason:

Many plastic pallets are constructed with materials that exhibit excellent fire performance, namely it is possible that they perform better than wood pallets. This is the case for pallets that have been made with plastics which have inherently good fire performance or with plastics that have been fire retarded. Both UL and FM label and list plastic pallets that meet a very severe fire test that involves full scale stacks of pallets. The FM standard, namely FM 4996, has been designed so that plastic pallets that meet the test are considered by FM as equivalent to wood pallets, both indoors and outdoors.

Testing using the tests above and using heat release tests has demonstrated that some plastic pallets can have not only equivalent fire performance to wood pallets but maybe even better fire performance. Several manufacturers of plastic pallets offer pallets that have been listed and labeled to the above standards. See some links below.

<http://www.orbiscorporation.com/products/plastic-pallets/fire-retardant-pallets#.WQkWZty1u70>

<http://www.rehrigpacific.com/products/supply-chain/plastic-pallets/fire-retardant-plastic-pallets>

<http://oneway-solutions.com/shop-plastic-pallets/fire-retardant-pallets>

<http://prostack.com/products/plastic-pallets/fm-approved-plastic-pallets/>

<http://packagingrevolution.net/plastic-pallet-manufacturer-receives-fm-approval-for-halogen-free-pallets/>

<http://www.rpmpasticpallets.com/products/fire-retardant-pallets/>

The IFC contains a section (3206.4.1.1) which states that "Plastic pallets listed and labeled in accordance with UL 2335 or FM 4996 shall be treated as wood pallets for determining required sprinkler protection." In view of this section and the listing and labeling by FM, plastic pallets listed and labeled to FM 4996 should be treated the same as wood pallets for outside storage in manufacturing and recycling facilities also, without changing the new section 2810 which is specific to wood pallets. The recommendation is simply that the same storage requirements should apply.

Concerns have been expressed that the fire performance of the plastic pallets that have been listed and labeled to FM 4996 may decrease over time. It is important to note two issues with regard to that:

(1) plastic materials used for manufacturing plastic pallets are not coated to achieve the appropriate fire performance in the fire test but are compounded so that the pallet material is homogeneous. The additives (if any are used) are incorporated into the material and mixed in before the material is made into the product (such as the pallet). Therefore this is different than the effect of treating fabrics or wood with fire retardant additives, which is done after the fabric is woven or spun and is typically superficial. Similarly the treatment to wood products is made after the wood is harvested and is not an integral portion of the wood.

(2) facilities that manufacture or recycle pallets are unlikely to store their products for long periods before sale and, therefore, the storage of these plastic pallets outdoors is likely to be of a relatively short duration.

Note that the plastic pallets to which this proposal applies will have to be labeled to indicate that they have been listed to FM 4996.

Bibliography:

FM 4996 - Approval Standard for Classification of Pallets and Other Material Handling Products as Equivalent to Wood Pallets - available at FM Global web site

Cost Impact

The code change proposal will decrease the cost of construction .

The proposal would allow more leeway for storage of plastic pallets listed and labeled to FM 4996 in facilities that manufacture or recycle them, without affecting fire safety.

Internal ID: 882

F17-18

IFC: 315.3.2, 1031.2, 3311.3 (New)

Proponent: Robert J Davidson, Davidson Code Concepts, LLC, representing Self (rjd@davidsoncodeconcepts.com)

2018 International Fire Code

Revise as follows:

315.3.2 Means of egress. Combustible materials shall not be stored in *exits*, fire-resistance-rated corridors or enclosures for *stairways* and *ramps*. Combustible materials in the means of egress during construction, demolition, remodeling or alterations shall comply with Section 3311.3.

1031.2 Reliability. Required *exit accesses*, *exits* and *exit discharges* shall be continuously maintained free from obstructions or impediments to full instant use in the case of fire or other emergency where the building area served by the *means of egress* is occupied. An *exit*, fire-resistance-rated corridor or *exit passageway* shall not be used for any purpose that interferes with a *means of egress*.

3311.3 Storage. Combustible materials associated with construction, demolition, remodeling or alterations to an occupied structure shall not be stored in exits, fire-resistance-rated corridors, enclosures for stairways and ramps, or exit access corridors serving an occupant load of 30 or more.

Exceptions:

1. Where the only occupants are construction workers.
2. Combustible materials that are temporarily accumulated to support work being performed when workers are present.

Reason:

This proposal is intended to correct an anomaly that occurred when two unrelated proposals by different submitters collided in impact when the 2012 codes were printed and causes some to believe fire-resistance-rated corridors are not "exits".

I had submitted a proposal that included modifying then Section 1030.2, (now 1031.2), by taking language that existed in other portions of Chapter 10 and adding them to 1030.2 since the requirements were ones that not only applied at the time of construction, but must be maintained for the life of the building or structure. (Proposal F151-09/10 attached).

The International Fire Code Development Committee approved the proposal.

The main premise was protecting "exits" and including existing language that stated "An exit or exit passageway shall not be used for any purpose other than as a means of egress."

Note that though Section 3311.3 was not part of the code when the anomaly occurred, it has been added to this submittal because it includes all fire-resistance rated paths of travel and additionally includes exit access corridors which could be non-rated paths of travel

At the time my proposal (F151-09/10) was submitted and approved the definition of exit in the code was:

"EXIT. That portion of a means of egress system which is separated from other interior spaces of a building or structure by fire-resistance-rated construction and opening protectives as required to provide a protected path of egress travel between the exit access and the exit discharge . Exits include exterior exit doors at the level of exit discharge , vertical exit enclosures , exit passageways , exterior exit stairways , exterior exit ramps and horizontal exits.

That definition included fire-resistance-rated corridors by virtue of the first sentence and represented what historically was considered an exit.

Unfortunately during that cycle a separate proposal in front of another committee included a proposal that changed the definition of an exit to:

"EXIT. That portion of a means of egress system between the exit access and the exit discharge or public way. Exit components include exterior exit doors at the level of exit discharge, interior exit stairways, interior exit ramps, exit passageways, exterior exit stairways and exterior exit ramps and horizontal exits."

The definition currently reads:

"[BE] EXIT. That portion of a means of egress system between the exit access and the exit discharge or public way. Exit components include exterior exit doors at the level of exit discharge, interior exit stairways and ramps, exit

passageways, exterior exit stairways and ramps and horizontal exits.

[BE] EXIT ACCESS. That portion of a means of egress system that leads from any occupied portion of a building or structure to an exit."

Because of the new definition and some language in the commentary generically referring to corridors as exit access, it is no longer clear if a fire-resistance-rated corridor is included in the two fire code sections addressing exits as intended by the proposal approved by the committee. The need to protect a fire-resistant-rated corridor is as important as protecting an exit passageway and other types of exits as documented by the following section:

"[BE] 1020.6 Corridor continuity. Fire-resistance-rated corridors shall be continuous from the point of entry to an exit, and shall not be interrupted by intervening rooms. Where the path of egress travel within a fire-resistance-rated corridor to the exit includes travel along unenclosed exit access stairways or ramps, the fire-resistance-rating shall be continuous for the length of the stairway or ramp and for the length of the connecting corridor on the adjacent floor leading to the exit.

Exceptions:

1. Foyers, lobbies or reception rooms constructed as required for corridors shall not be construed as intervening rooms.
2. Enclosed elevator lobbies as permitted by Item 1 of Section 1016.2 shall not be construed as intervening rooms."

By adding the wording "fire-resistance-rated corridor" to the two sections in this proposal the intent of the committee approval of F151-09/10 will be met.

F151-09/10

1030.2, 1030.2.1, 1030.6, 1030.9 (New)

Proponent: Robert J Davidson, Code Consultant/Alan Shuman, President, representing the National Association of State Fire Marshals (NASFM)

1. Revise as follows:

1030.2 Reliability. Required exit accesses, exits or exit discharges shall be continuously maintained free from obstructions or impediments to full instant use in the case of fire or other emergency when the areas served by such exits are occupied. An exit or exit passageway shall not be used for any purpose other than as a means of egress.

1030.2.1 Security devices and egress locks. Security devices affecting means of egress shall be subject to approval of the fire code official. Special locking arrangements including, but not limited to access-controlled egress doors, security grills, locks and latches, and delayed egress locks shall be installed and maintained as required by this chapter.

1030.6 Finishes, furnishings and decorations. Means of egress doors shall be readily maintained in such a manner as to be distinguishable from the adjacent construction and finishes such that the doors are easily recognizable as doors. Furnishings, decorations or other objects shall not be placed so as to obstruct exits, access thereto, egress therefrom, or visibility thereof. Hangings and draperies shall not be placed over exit doors or otherwise be located to conceal or obstruct an exit. Mirrors shall not be placed on exit doors. Mirrors shall not be placed in or adjacent to any exit in such a manner as to confuse the direction of exit.

2. Add new text as follows:

1030.9 Floor identification signs. The floor identification signs required by Sections 1022.8 and 4504.22 shall be maintained in an approved manner.

Reason: The proposed modification Section 1030.2 has taken language that currently exists in Sections 1020.1 and 1023.1 and added it to this section since the requirement is one that not only applies at the time of construction, but must be maintained for the life of the building or structure.

1020.1 General. Exits shall comply with Sections 1020 through 1026 and the applicable requirements of Section 1003 through 1012. An exit shall not be used for any purpose that interferes with its function as a means of egress. Once a given level of exit protection is achieved, such level of protection shall not be reduced until arrival of the exit discharge.

1023.1 Exit passageway. Exit passageways serving as an exit component in a means of egress system shall comply with the requirements of this section. An exit passageway shall not be used for any purpose other than as a means of egress.

The last sentence of Section 1030.2 addressing "security" is a special topic and has been separated out and designated as 1030.2.1. Language has been added to make it clear any of a number of methods used to control the use of or secure egress doors must be done in compliance with Chapter 10, which has specific provisions governing the installations when approved.

The proposed change to 1030.6 takes a restriction found in Section 1008.1 that equally applies to new construction, but also must be addressed through the life of the building or structure. It is not uncommon for a building owner to refinish the inside of an occupancy and paint or otherwise apply a matching finish to a door and the surrounding wall making the door indistinguishable. This commonly occurs with murals that are painted on walls of corridors.

1008.1 Doors. Means of egress doors shall meet the requirements of this section. Doors serving a means of egress system shall meet the requirements of this section and Section 1017.2. Doors provided for egress purposes in numbers greater than required by this code shall meet the requirements of this section.

Means of egress doors shall be readily distinguishable from the adjacent construction and finishes such that the doors are easily recognizable as doors. Mirrors or similar reflecting materials shall not be used on means of egress doors. Means of egress doors shall not be concealed by curtains, drapes, decorations or similar materials.

A new Section 1030.9 is proposed which references the language found in existing Section 1022.8. The requirement for the maintenance of signs designating floor levels in interior stairway exit enclosures has equal importance in existing buildings.

Cost Impact: The code change proposal will not increase the cost of construction other than the signs needed for compliance with proposed Section 1022.8.

Public Hearing:	Committee:	AS	AM	D
	Assembly:	ASF	AMF	DF

ICCFLENAME: DAVIDSON-SHUMAN-F3-1030.2.DOC

Cost Impact

The code change proposal will not increase or decrease the cost of construction .

Since this proposal addresses a topic that deals with maintenance of a exit path during day to day activities, it does not impact the cost of construction.

Analysis: Note that this proposal includes sections that are part of an errata to the 2018 IFC. Section 315.3.2 the second sentence is new and Section 3311.3 is a new section to the 2018 that was inadvertently missed during publication.

F18-18

IFC: 315.8 (New); IBC: [F] 307.1, [F]307.4

Proponent: Robert Davidson, Davidson Code Concepts, LLC, representing Tesla, USA
(rjd@davidsoncodeconcepts.com)

2018 International Fire Code

Add new text as follows:

315.8 Used or Off Specification Lithium-Ion Batteries. The storage of used or off specification lithium-ion batteries shall comply with the following as appropriate:

1. Gathering locations in occupancies other than those involving Mercantile occupancy battery recycling activities shall comply with Section 315.8.1.
2. Mercantile occupancy battery sale recycling activities shall comply with Section 315.8.2.
3. Indoor collection and storage activities exceeding the limitations of Sections 315.8.1 or Section 315.8.2 occurring in mixed occupancy buildings shall comply with Section 315.8.3.
4. Indoor storage and recycling activities in detached buildings shall comply with Section 315.8.4.
5. Outdoor storage shall comply with Section 315.8.5.

315.8.1 Gathering locations. Indoor storage of used and off specification lithium-ion batteries being gathered for shipment to recycling facilities shall be in rooms or spaces protected by an automatic sprinkler system complying with Section 903.3.1.1. Batteries quantities shall not exceed one cubic ft. (0.03 m³) per fire area, and the batteries shall be stored in open top noncombustible containers spaced a minimum 3 ft. (914 mm) from combustible materials and a minimum 10 feet (3048 mm) from exits from the room, space or building.

315.8.2 Mercantile battery sale recycling locations. Rooms or spaces associated with mercantile battery sale recycling activities shall not exceed 100 sq. ft. in size. The rooms or spaces shall be separated from the remainder of the building areas by two-hour fire barriers constructed in accordance with Section 707 of the International Building Code and two-hour horizontal assemblies constructed in accordance with Section 711 of the International Building Code, as appropriate. The room or space shall be protected by a radiant-energy detection system installed in accordance with NFPA 72 and shall be protected by an automatic sprinkler system designed and installed in accordance with Section 903.3.1.1.

315.8.3 Indoor storage in mixed occupancies. Mixed occupancy indoor storage and recycling activities not meeting the limitations of Section 315.8.1 or Section 315.8.2 shall be classified as a Group H-2 occupancy and shall be in rooms or spaces not exceeding 5000 sq. ft. (464 m²) in area separated from the remainder of the building areas by three-hour fire barriers constructed in accordance with Section 707 of the International Building Code and three-hour horizontal assemblies constructed in accordance with Section 711 of the International Building Code, as appropriate.

Individual pile sizes shall be limited to sixty-four cubic ft. (1.81 m³) with a 5 foot separation to the next pile. Piles shall not be located within 10 feet of exits from the room, space or building.

315.8.3.1 Prevention and Mitigation. Occupancies storing used or off specification lithium-ion batteries shall have a plan approved by the fire code official that provides for the prevention of fire incidents and includes early detection mitigation measures.

315.8.3.2 Fire detection. The room or space shall be protected by a radiant-energy detection system installed in accordance with Section 907.

315.8.3.3 Fire suppression. The building the battery storage is located in shall be provided with an automatic fire suppression system installed in accordance with Section 903.1.1. The Group H-2 battery storage room or space shall be protected by a NFPA 15 water spray automatic suppression system installed in accordance with Section 904.12 with a density based on large scale fire testing complying with Section 1206.2.11.

315.8.3.4 Explosion protection. Explosion protection shall be installed in accordance with Section 911.

315.8.4 Detached buildings. Indoor storage and recycling activities shall be permitted in Group H-2 detached buildings located more than 100 feet (30.5 M) from buildings, lot lines, public ways, stored combustible materials, hazardous materials, high piled stock and other exposure hazards. The storage shall comply with the following:

1. Individual rooms or areas inside the building shall not exceed 7,000 sq ft (650 m²) and shall be are separated from other areas by three hour fire barriers constructed in accordance with Section 707 of the International Building Code and three-hour horizontal assemblies constructed in accordance with Section 711 of the International Building Code, as appropriate.
2. The building shall be protected by a radiant-energy detection system installed in accordance with Section 907.
3. Any area containing lithium-ion batteries shall be protected by a NFPA 15 water spray automatic suppression system installed in accordance with Section 904.12 with a density based on large scale fire testing complying with Section 1206.2.11.
4. Explosion protection shall be installed in accordance with Section 911.
5. Individual pile sizes shall be limited to sixty-four cubic ft. (1.81 m³) with a 5 foot separation to other piles, walls, appliances and equipment. Piles shall not be located within 10 feet of exits from the room, space or building. There shall be no more than 64 piles per room or space.
6. A plan approved by the fire code official that provides for the prevention of fire incidents and includes early detection mitigation measures.

315.8.5 Outdoor storage. Outdoor storage shall comply with the following:

1. Individual pile sizes shall be limited to sixty-four cubic ft. (1.81 m³).
2. Piles located outdoors shall be separated by a minimum 100 feet (30.5 M) from the following exposures:
 - 2.1 Lot lines
 - 2.2 Public ways
 - 2.3 Buildings
 - 2.4 Stored combustible materials
 - 2.5 Hazardous materials
 - 2.6 High-piled stock
 - 2.7 Other exposure hazards

Exception: Clearances are permitted to be reduced to 3 ft. (914 mm) when a 3-hour free standing fire barrier, suitable for exterior use, and extending 15 ft. (1.5 m) above and extending 15 ft (1.5 m) beyond the physical boundary of the pile is provided to protect the exposure.

2018 International Building Code

[F] 307.1 High-hazard Group H. High-hazard Group H occupancy includes, among others, the use of a building or structure, or a portion thereof, that involves the manufacturing, processing, generation or storage of materials that constitute a physical or health hazard in quantities in excess of those allowed in *control areas* complying with Section 414, based on the maximum allowable quantity limits for *control areas* set forth in Tables 307.1(1) and 307.1(2). Hazardous occupancies are classified in Groups H-1, H-2, H-3, H-4 and H-5 and shall be in accordance with this section, the requirements of Section 415 and the International Fire Code. Hazardous materials stored, or used on top of roofs or canopies, shall be classified as outdoor storage or use and shall comply with the International Fire Code.

Revise as follows:

[F] 307.4 High-hazard Group H-2. Buildings and structures containing materials that pose a deflagration hazard or a hazard from accelerated burning shall be classified as Group H-2. Such materials shall include, but not be limited to, the following:

- Class I, II or IIIA flammable or combustible liquids that are used or stored in normally open containers or systems, or in closed containers or systems pressurized at more than 15 pounds per square inch gauge (103.4 kPa).
- Combustible dusts where manufactured, generated or used in such a manner that the concentration and conditions create a fire or explosion hazard based on information prepared in accordance with Section 414.1.3.

- Cryogenic fluids, flammable.
- Flammable gases.
- Organic peroxides, Class I.
- Oxidizers, Class 3, that are used or stored in normally open containers or systems, or in closed containers or systems pressurized at more than 15 pounds per square inch gauge (103 kPa).
- Pyrophoric liquids, solids and gases, nondetonable.
- Storage of used or off specification lithium-ion batteries in mixed use or detached buildings shall be in accordance with Section 315.8 of the International Fire Code.
- Unstable (reactive) materials, Class 3, nondetonable.
- Water-reactive materials, Class 3.

Reason:

Lithium-ion batteries have significant fire and explosion hazards and there have been some serious fires and explosions associated with storage of used batteries in recycling and disposal facilities, including a serious event in Hilden Germany that seriously injured three fire fighters.

This proposal adds requirements for protecting storage of lithium-ion batteries being stored on premise prior to sending to recycling or disposal facilities, and for storage at recycling or disposal facilities. The requirements are broken down to address those with a small collection area, mercantile occupancies that have collection areas for returned batteries, storage at recycling or disposal facilities in mixed use buildings and storage at recycling or disposal facilities in detached buildings. The hazard is addressed by adding requirements for fire protection features, amounts that can be present, and fire-resistant construction separation. The larger areas permitted for storage at recycling or disposal facilities in mixed use and detached buildings will be classified as an H-2 Group. The outdoor storage setback requirements are consistent with setback requirements for outdoor electrochemical energy storage system installations.

This proposal is submitted by the ICC Fire Code Action Committee (FCAC). The FCAC was established by the ICC Board of Directors to pursue opportunities to improve and enhance assigned International Codes with regard to fire safety and hazardous materials in new and existing buildings and facilities and the protection of life and property in wildland urban interface areas. In 2017 the Fire-CAC has held 3 open meetings. In addition, there were numerous conference calls, Regional Work Group and Task Group meetings for the current code development cycle, which included members of the committees as well as any interested parties, to discuss and debate the proposed changes. Related documentation and reports are posted on the FCAC website at: <https://www.iccsafe.org/codes-tech-support/cs/fire-code-action-committee-fcac/>

Cost Impact

The code change proposal will not increase or decrease the cost of construction .

However this will limit the facilities where used or off specification lithium-ion batteries can be stored.

Internal ID: 315

F19-18

IFC: 317.2

Proponent: Jason Wilen AIA CDT RRO, National Roofing Contractors Association (NRCA), representing National Roofing Contractors Association (NRCA) (jwilen@nrca.net)

2018 International Fire Code

Revise as follows:

317.2 Rooftop garden or landscaped roof size. Rooftop garden or landscaped roof areas shall not exceed 15,625 square feet (1450 m²) in size for any single area with a maximum dimension of 125 feet (39 m) in length or width. A minimum 6-foot-wide (1.8 m) clearance consisting of a listed Class A ~~rated roof system complying roof assembly~~ tested in accordance with ASTM E108 or UL 790 shall be provided between adjacent rooftop gardens or landscaped roof areas.

Reason:

The purpose of this change is to improve the consistency of similar text noted in multiple I-Codes. The reference to a “Class A rated roof system” in Section 317.2 is similar to text in IBC Section 1505.1; the IBC section that establishes how Class A roof assemblies are determined. The proposed change borrows text from IBC Section 1505.1 improving consistency and making clear an assembly (not a system) evaluation is necessary as per ASTM E108 and UL 790—the test methods referenced in both IFC section 317.2 and IBC section 1505.1.

Cost Impact

The code change proposal will not increase or decrease the cost of construction .

The proposed change does not change the stringency of the code.

Internal ID: 1224

F20-18

IFC: 319.9.1.3, Chapter 80, CSA Group (New)

Proponent: Michael O'Brian, Chair, representing FCAC (fcac@iccsafe.org)

2018 International Fire Code

319.9.1.3 CNG container construction. CNG containers shall be an NGV-2 cylinder.

Add new standard(s) follows:

CHAPTER 80 REFERENCED STANDARDS

CSA Group

CSA/ANSI NGV 2-2016

Compressed natural gas vehicle fuel containers

Reason:

During the development cycle for 2018 IFC Section 319 was added to address requirements for mobile food preparation vehicles. Section 319.3.1.3 required that natural gas supply be from containers listed as NGV-2 containers. However, the NGV-2 reference standard was not included with the reference standards of Chapter 80. This proposal attempts to fix the oversight by referencing the latest edition of the standard.

This proposal is submitted by the ICC Fire Code Action Committee (FCAC). The FCAC was established by the ICC Board of Directors to pursue opportunities to improve and enhance assigned International Codes with regard to fire safety and hazardous materials in new and existing buildings and facilities and the protection of life and property in wildland urban interface areas. In 2017 the Fire-CAC has held 3 open meetings. In addition, there were numerous conference calls, Regional Work Group and Task Group meetings for the current code development cycle, which included members of the committees as well as any interested parties, to discuss and debate the proposed changes. Related documentation and reports are posted on the FCAC website at: <https://www.iccsafe.org/codes-tech-support/cs/fire-code-action-committee-fcac/>

Cost Impact

The code change proposal will not increase or decrease the cost of construction .

This is simply adding the appropriate referenced standard and will have no cost impact. The standard is already referenced.

Analysis: A review of the standard proposed for inclusion in the code, CSA/ANSI NGV 2-2016, with regard to the ICC criteria for referenced standards (Section 3.6 of CP#28) will be posted on the ICC website on or before April 2, 2018.

Internal ID: 289

F21-18

IFC: SECTION 320 (New), 320.1 (New)

Proponent: Marcelo Hirschler, representing GBH International (gbhint@aol.com)

2018 International Fire Code

Add new text as follows:

SECTION 320 ARTIFICIAL DECORATIVE VEGETATION

320.1 General. Artificial decorative vegetation placed outdoors, either within 30 feet (9140 mm) of a building, or on an occupied roof of a building, shall comply with Sections 807.4.1 and 807.4.2

Reason:

There is abundant evidence that combustible materials outdoors can cause severe fires that can spread to a nearby building. One example is artificial decorative vegetation. The recent fire at the Cosmopolitan Hotel in Las Vegas (which involved unregulated decorative vegetation) has demonstrated that combustible materials in occupiable roofs can also cause significant fire damage. The distance of 30 feet was chosen because it is considered the distance beyond which accessory structures in wildland areas cease being a serious fire safety concern. The fire testing recommended (807.4.1) is the same as for indoor artificial vegetation, namely either NFPA 701 (test methods 1 or 2, as appropriate, based on the type of material) or NFPA 289, with a 20 kW ignition source. The additional requirement (807.4.2) is that no unlisted electrical wiring or lighting is permitted on the decorative vegetation item.

Cost Impact

The code change proposal will increase the cost of construction .

Artificial decorative vegetation used outdoors near a building or on a roof will have to be fire tested.

Internal ID: 2327

F22-18

IFC: 105.6.1 (New), 202(New), 301.2, 302.1, 320 (New), Chapter 80

Proponent: Michael O'Brian, Chair, representing FCAC (fcac@iccsafe.org)

2018 International Fire Code

Add new text as follows:

105.6.1 Additive Manufacturing. An operational permit is required to conduct additive manufacturing operations as covered in Section 320.3.

3D PRINTER. A machine used in the additive manufacturing process for fabricating objects through the deposition of a material using a print head, nozzle, or another printer technology.

ADDITIVE MANUFACTURING. A process of joining materials to make objects from 3D model data, usually layer upon layer, sometimes referred to as 3D printing. The Code recognizes two types of additive manufacturing:

Industrial additive manufacturing. 3D printing that uses equipment external to the 3D printer for feed of powders or dust collection.

Non-industrial additive manufacturing. 3D printing which exclusively uses self-contained 3D printing equipment without external powder supply, dust collection system, or inert gas supply.

Revise as follows:

301.2 Permits. Permits shall be required as set forth in Section 105.6 for the activities or uses regulated by Sections 306, 307, 308, 315 and ~~315-320~~.

302.1 Definitions. The following terms are defined in Chapter 2:

3D PRINTER.

ADDITIVE MANUFACTURING.

BONFIRE.

HI-BOY.

HIGH-VOLTAGE TRANSMISSION LINE.

OPEN BURNING.

PORTABLE OUTDOOR FIREPLACE.

POWERED INDUSTRIAL TRUCK.

RECREATIONAL FIRE.

SKY LANTERN.

Add new text as follows:

SECTION 320 ADDITIVE MANUFACTURING (3D PRINTING)

320.1 General. Additive manufacturing equipment and operations shall comply with Section 320.

320.1.1 Scope. Additive manufacturing shall comply with one of the following:

1. Non-industrial additive manufacturing shall comply with Section 320.2.
2. Industrial additive manufacturing shall comply with Section 320.3.

320.2 Non-industrial additive manufacturing. Non-industrial additive manufacturing equipment and operations shall comply with Section 320.2.1 through 320.2.5.

320.2.1 Industrial manufacturing. Non-industrial additive manufacturing equipment and operations shall comply

with Section 320.2. Additive manufacturing equipment and operations that do not comply with 320.2.1 through 320.2.5 shall comply with Section 320.3.

320.2.2 Listing. 3D printers used in non-industrial additive manufacturing shall be listed and labeled in accordance with UL 60950-1 or UL 62368-1. The listing shall also verify:

1. The 3D printers are self-contained and do not utility ancillary equipment, other than pre-packaged production materials.
2. The operation of the 3D printers will not create a hazardous (classified) environment outside of the unit's outer enclosure as defined in NFPA 70, Article 500.
3. The 3D printers are only intended for use with maximum 30 liter prepackaged production materials, which are investigated with the 3D printer and identified in the manufacturer's instruction.

320.2.3 Installation, operation and maintenance. 3D printers shall be installed, operated and maintained in accordance with this Code, the listing and the manufacturer's instructions.

320.2.4 Installation limitations. Non-industrial additive manufacturing shall be limited to installations and operations that comply with all of the following:

1. Do not utilize external dust collection systems.
2. Do not utilize external inert gas supplies for creating an inert environment.
3. Do not utilize automated external powder feed or sieve features.
4. Do not utilize hazardous materials in excess of the maximum allowable quantities regulated by Chapter 50.

320.2.5 Occupancies. Non-industrial additive manufacturing shall be permitted in all occupancy groups.

320.3 Industrial additive manufacturing. Industrial additive manufacturing equipment and operations shall comply with Section 320.3.1 through 320.3.9.

320.3.1 Additive manufacturing operations and equipment. Additive manufacturing operations and equipment that do not comply with Section 320.2 shall comply with Section 320.3.

320.3.2 Permits required. Permits shall be obtained from the fire code official in accordance with Section 105.6 prior to engaging in industrial additive manufacturing operations.

320.3.3 Listing. 3D printers used in industrial additive manufacturing shall be listed and labeled in accordance with UL 2011 or approved for the application based on a field evaluation conducted by an approved agency.

320.3.4 Installation, operation and maintenance. Industrial additive manufacturing equipment shall be installed, operated and maintained in accordance with this code, the manufacturer's instructions and where applicable the listing.

320.3.5 Combustible dusts and metals. Industrial additive manufacturing operations that use or generate combustible dust or combustible metals shall comply with Chapter 22, Chapter 50 and this section.

320.3.5.1 Powder evaluation. Printing powders used in industrial additive manufacturing operations shall be tested for combustibility in accordance with NFPA 484 or 654 as applicable. A copy of test reports shall be provided to the fire code official upon request.

320.3.5.2 Combustible (non-metallic) dusts. Industrial additive manufacturing that uses combustible (non-metallic) dusts shall comply with NFPA 654.

320.3.5.3 Combustible metals. Industrial additive manufacturing operations that use combustible metals shall also comply with NFPA 484.

320.3.5.4 Ancillary equipment. Ancillary equipment provided for recycling, sieving, vacuuming or handling combustible powders shall be designed and approved for such use.

320.3.6 Hazardous materials. Industrial additive manufacturing operations that use hazardous materials exceeding the maximum allowable quantities shall comply with Chapter 50.

320.3.7 Technical assistance. Where required by the fire code official, a report evaluating the acceptability of technologies, processes, products, facilities, materials and uses associated with the operation shall be provided in accordance with 104.7.2 and approved.

320.3.8 Performance based design alternative. Where approved by the fire code official, buildings and facilities where industrial additive manufacturing is performed shall be permitted to comply with the performance based design options in Section 5001.3 as an alternative to compliance with the other requirements set forth in this Section.

320.2.9 Occupancies. Industrial additive manufacturing shall only be conducted in the occupancy groups associated with manufacturing operation, and permitted by the Chapter 50 maximum allowable quantity tables. Where approved, the requirements in Section 320.3.6 shall be permitted to provide the technical basis for determining compliance with Table 5003.1.1(1), footnote q.

Add new standard(s) follows:

UL

Underwriters Laboratories LLC
333 Pfingsten Road
Northbrook IL 60062

2011-06:

Factory Automation Equipment

60950-1—14:

Information Technology Equipment - Safety Requirements

62368-1—14:

Audio/video, Information and Communication Technology Equipment - Safety Requirements

Reason:

The use of additive manufacturing, often referred to as 3D printing, is becoming more prevalent in industrial and non-industrial applications. This proposal introduces basic safety requirements for these operations.

Non-industrial additive manufacturing - 3D printers are available for less than \$500 and are being used in classrooms, offices and businesses for producing customized products and prototypes. Section 320.2 establishes basic safety requirements for this self-contained equipment, which includes pre-packaged production materials. The product listing is being relied upon to verify that the equipment operates safely and does not create a hazardous (classified) area outside of the unit.

Industrial use additive manufacturing - Section 320.3 covers 3D additive manufacturing operations, which includes all operations that aren't covered by Section 320.2. These are typically industrial operations using external powder feed supplies, dust collection systems and/or inert gas supplies. Some of the requirements for industrial operations are as follows:

320.3.3 requires the industrial 3D printer to be listed to UL 2011, but includes an option for non-listed equipment to be approved based on a field evaluation.

320.3.6 was added due to the new unique challenges some jurisdictions may face in approving industrial additive manufacturing operations. Among other resources they can use is a risk assessment conducted in accordance with the UL 3400 Outline of Investigation for Additive Manufacturing Facility Safety Management, which is applicable where parts are manufactured using powder-based additive manufacturing techniques.

This section also includes a pointer to the Section 5001.3 performance based design option, which has been used in some industrial additive manufacturing operations.

An operational permit is required for industrial additive operations.

This proposal is submitted by the ICC Fire Code Action Committee (FCAC). The FCAC was established by the ICC Board of Directors to pursue opportunities to improve and enhance assigned International Codes with regard to fire safety and hazardous materials in new and existing buildings and facilities and the protection of life and property in wildland urban interface areas. In 2017 the Fire-CAC has held 3 open meetings. In addition, there were numerous conference calls, Regional Work Group and Task Group meetings for the current code development cycle, which included members of the committees as well as any interested parties, to discuss and debate the proposed changes. Related documentation and reports are posted on the FCAC website at: <https://www.iccsafe.org/codes-tech-support/cs/fire-code-action-committee-fcac/>

Cost Impact

The code change proposal will increase the cost of construction .

There is no significant cost increase for non-industrial additive manufacturing covered by Section 320.2, unless the price of listed equipment is higher than non-listed equipment. There are increased costs for industrial additive manufacturing operations that might be related to obtaining listed equipment, and the operational permit fees.

Analysis: A review of the standard proposed for inclusion in the code, UL 2011-06, UL 60950-1-14, and UL 62368-1—14, with regard to the ICC criteria for referenced standards (Section 3.6 of CP#28) will be posted on the ICC website on or before April 2, 2018.

Internal ID: 306

F23-18

IFC: SECTION 320 (New), 320.1 (New), 320.2 (New), 320.3 (New), 320.4 (New), 320.5 (New), 320.6 (New)

Proponent: Marcelo Hirschler, GBH International, representing GBH International (gbhint@aol.com)

2018 International Fire Code

Add new text as follows:

SECTION 320 OUTDOOR FURNITURE AFFIXED OUTSIDE BUILDINGS

320.1 General. Outdoor furniture, such as benches, that are affixed outside buildings, shall be considered storage and shall comply with section 315 and this section.

Exception: Outdoor furniture placed beneath overhead projections from buildings where automatic sprinklers are installed under such projections in accordance with Section 315.4.1.

320.2 Distance from buildings. Furniture placed outdoors shall not be affixed within 5 feet (1524 mm) of any building, except if it is labeled as having complied with any one of Sections 320.3 through 320.6.

320.3 Traditional materials. The furniture shall be constructed entirely of wood, identified for outdoor use, and non-combustible materials, complying with Section 703.5.1 of the International Building Code.

320.4 Plastic composites. The furniture shall be constructed entirely of materials that meet all the requirements for plastic composite deck boards, in accordance with section 2612 of the International Building Code.

320.5 Heat release. The furniture shall be constructed entirely of materials intended for outdoor use that exhibit a peak rate of heat release not exceeding 300 kW/m² when tested in accordance with ASTM E 1354 at an incident heat flux of 50 kW/m² in the horizontal orientation.

320.6 Full scale testing. The furniture shall be constructed entirely of materials intended for outdoor use and the entire item of furniture shall exhibit a maximum rate of heat release not exceeding 100 kW when tested in accordance with NFPA 289, using the 20 kW ignition source.

Reason:

Section 315 of the IFC addresses storage, including, particularly, storage beneath overhead projections from buildings (Section 315.4.1). However, storage is defined as something intended for future use. The IFC code does not make it clear whether items placed permanently (for example by being secured or screwed in place) near a building (or against a building) for their immediate use are necessarily considered to be “stored” and whether the storage section applies.

It has been found that when plastic benches are attached to buildings and placed underneath overhead projections, they can result in severe fires that can destroy the overhang and then continue to destroy the building itself. ATF conducted tests on several plastic lumber benches simulating an actual incident. In the incident, a plastic lumber bench attached to a brick wall, from the outside, at a school and under an overhang, was ignited with a small ignition source (child’s coat) and the entire school was destroyed soon after ignition. Tests conducted by GBH International showed that a Southern Yellow Pine (standard park bench lumber) would have performed much better and that even some plastic lumber materials could have done much better. The maximum heat release rate of plastic lumber bench ignited in this type of scenario is very high and can be above 4 MW, while the wood bench did not ignite the overhang. An attached set of pictures and information shows key results.

It is interesting that the IFC does an excellent job in regulating garbage cans and laundry carts placed near buildings (even if they are not secured in place) but it does not regulate park benches, or other park furniture.

It has been explained that the practice of placing park benches under an overhang is a common feature in areas where rain is frequent, for protection.

The code proposal would allow benches, or other outdoor furniture, constructed of wood or of non-combustible materials without further requirements (traditional materials).

If plastic benches (or plastic composite benches) are proposed to be placed near buildings, the proposal states that they need to comply with one of the following: (a) the same requirements as plastic composites used for deck boards (i.e. section 2612 of the IBC), (b) the same heat release results from ASTM E1354 that materials used for garbage cans or laundry carts are required to meet (i.e. section 304.3 or 318.1) or the same heat release results as decorative

materials (i.e. section 807.3) or foam plastic exhibit booths (i.e. section 807.5.1) are required to meet.

At the same time the code proposal clarifies that combustible products placed for immediate use outside buildings must comply with the same storage requirements as those stored for future use, in section 315. This means that if the furniture is placed beneath overhead projections, automatic sprinklers must be installed under such projections, per 315.4.1, as shown below.

315.4.1 Storage beneath overhead projections from buildings. Where buildings are protected by an automatic sprinkler system, the outdoor storage, display and handling of combustible materials under eaves, canopies or other projections or overhangs are prohibited except where automatic sprinklers are installed under such eaves, canopies or other projections or overhangs.

Cost Impact

The code change proposal will increase the cost of construction .

This code proposal will require that outdoor furniture affixed near a building must have improved fire performance, which will improve fire safety.

Internal ID: 1016

F24-18

IFC: 403.3, 403.3.1, 403.3.2, 403.3.3, 403.3.4, 403.8.2

Proponent: John Williams, Chair, representing Healthcare Committee (AHC@iccsafe.org); Michael O'Brian, Chair, representing FCAC (fcac@iccsafe.org)

2018 International Fire Code

403.4 Group B occupancies. An *approved* fire safety and evacuation plan in accordance with Section 404 shall be prepared and maintained for buildings containing a Group B occupancy where the Group B occupancy has an *occupant load* of 500 or more persons or more than 100 persons above or below the lowest *level of exit discharge* and for buildings having an ambulatory care facility.

Revise as follows:

~~403.3.4~~**403.4.1 Ambulatory care facilities.** Ambulatory care facilities shall comply with the requirements of Sections 401, 403.3.1 through 403.3.4 and 404 through 406.

~~403.3.14~~**403.4.1.1 Fire evacuation plan.** The fire safety and evacuation plan required by Section 404 shall include a description of special staff actions. This shall include procedures for stabilizing patients in a defend-in-place response, staged evacuation, or full evacuation in conjunction with the entire building if part of a multitenant facility.

~~403.3.24~~**403.4.1.1.1 Fire safety plan.** A copy of the plan shall be maintained at the facility at all times. The plan shall include all of the following in addition to the requirements of Section 404:

1. Locations of patients who are rendered incapable of self-preservation.
2. Maximum number of patients rendered incapable of self-preservation.
3. Area and extent of each ambulatory care facility.
4. Location of adjacent smoke compartments or refuge areas, where required.
5. Path of travel to adjacent smoke compartments.
6. Location of any special locking, delayed egress or access control arrangements.

~~403.3.34~~**403.4.1.2 Staff training.** Employees shall be periodically instructed and kept informed of their duties and responsibilities under the plan. Records of instruction shall be maintained. Such instruction shall be reviewed by the staff not less than every two months. A copy of the plan shall be readily available at all times within the facility.

~~403.3.44~~**403.4.1.3 Emergency evacuation drills.** Emergency evacuation drills shall comply with Section 405.

Exception: The movement of patients to safe areas or to the exterior of the building is not required.

403.8 Group I occupancies. An *approved* fire safety and evacuation plan in accordance with Section 404 shall be prepared and maintained for Group I occupancies. Group I occupancies shall comply with Sections 403.8.1 through 403.8.3.4.

403.8.1 Group I-1 occupancies. Group I-1 occupancies shall comply with Sections 403.8.1.1 through 403.8.1.7.

403.8.2 Group I-2 occupancies. Group I-2 occupancies shall comply with Sections ~~401,~~403.8.2.1 through 403.8.2.3 and ~~404~~ through 406.

403.8.3 Group I-3 occupancies. Group I-3 occupancies shall comply with Sections 403.8.3.1 through 403.8.3.4.

403.10 Group R occupancies. Group R occupancies shall comply with Sections 403.10.1 through 403.10.3.6.

403.10.3 Group R-4 occupancies. An *approved* fire safety and evacuation plan in accordance with Section 404 shall be prepared and maintained for Group R-4 occupancies. Group R-4 occupancies shall comply with Sections 403.10.3.1 through 403.10.3.6.

Reason:

This is a series of proposal to coordinate the fire safety, evacuation and lock down plans between Groups I-1, I-2, I-3, R-4 and ambulatory care facilities. The FCAC and Healthcare committees worked together to address all situations where a staged evacuation or defend-in-place is utilized. At the end of this reason is a clean version of what these

sections would look like if all the proposals pass.

This proposal moves specific ambulatory care facility criteria so that it is a subset of Group B. Per the last phrase in Section 403.4 – so this is where it belongs. In Section 403.8.2, the reference to 401 and 404 through 406 is inconsistent and not necessary – These sections would already be required where applicable.

This proposal is submitted by the ICC Fire Code Action Committee (FCAC), and ICC Committee on Healthcare (CHC).

The FCAC was established by the ICC Board of Directors to pursue opportunities to improve and enhance assigned International Codes with regard to fire safety and hazardous materials in new and existing buildings and facilities and the protection of life and property in wildland urban interface areas. In 2017 the Fire-CAC has held 3 open meetings. In addition, there were numerous conference calls, Regional Work Group and Task Group meetings for the current code development cycle, which included members of the committees as well as any interested parties, to discuss and debate the proposed changes. Related documentation and reports are posted on the FCAC website at: <https://www.iccsafe.org/codes-tech-support/cs/fire-code-action-committee-fcac/>

The CHC was established by the ICC Board to evaluate and assess contemporary code issues relating to healthcare facilities. This is a joint effort between ICC and the American Society for Healthcare Engineering (ASHE), a subsidiary of the American Hospital Association, to eliminate duplication and conflicts in healthcare regulation. In 2017 the CHC held 2 open meetings and numerous conference calls, which included members of the committees as well as any interested parties, to discuss and debate the proposed changes. Information on the CHC, including: meeting agendas; minutes; reports; resource documents; presentations; and all other materials developed in conjunction with the CHC effort can be downloaded from the CHC website at: <https://www.iccsafe.org/codes-tech-support/cs/icc-committee-on-healthcare/>.

The following is the Fire and Safety Evacuation plans for ambulatory care, Group I-1, I-2, I-3 and R-4 if all proposals pass.

403.4 Group B occupancies. An approved fire safety and evacuation plan in accordance with Section 404 shall be prepared and maintained for buildings containing a Group B occupancy where the Group B occupancy has an occupant load of 500 or more persons or more than 100 persons above or below the lowest level of exit discharge and for buildings having an ambulatory care facility.

403.4.1 Ambulatory care facilities. Ambulatory care facilities shall comply with the requirements of Sections 403.3.1 through 403.3.4.

403.4.1.1 Fire safety and evacuation plan. The fire safety and evacuation plan required by Section 404 shall include a description of special staff actions. This shall include procedures for stabilizing care recipients in a defend-in-place response, staged evacuation, or full evacuation in conjunction with the entire building if part of a multitenant facility.

403.4.1.1.1 Fire safety plan. A copy of the fire safety plan shall be maintained at the facility at all times. The plans shall include all of the following in addition to the requirements of Section 404.2.2:

1. Locations of care recipients who are rendered incapable of self-preservation.
2. Maximum number of care recipients rendered incapable of self-preservation.
3. Area and extent of each ambulatory care facility.
4. Location of any special locking-arrangements.

403.4.1.2 Staff training. Staff shall be periodically instructed and kept informed of their duties and responsibilities under the plan. Records of instruction shall be maintained. Such instruction shall be reviewed by the staff at intervals not exceeding three months. Training of new staff shall be provided promptly upon entrance to duty.

Staff shall be instructed in the proper use of portable fire extinguishers and other manual fire suppression equipment.

403.8 Group I occupancies. An approved fire safety and evacuation plan in accordance with Section 404 shall be prepared and maintained for Group I occupancies. Group I occupancies shall comply with Sections 403.8.1 through 403.8.3.4.

403.8.1 Group I-1 occupancies. Group I-1 occupancies shall comply with Sections 403.8.1.1 through 403.8.1.7.

403.8.1.1 Fire safety and evacuation plan. The fire safety and evacuation plan required by Section 404 shall include a description of special staff actions. The plans shall include all of the following in addition to the requirements of Section 404.

Procedures for full evacuation of care recipients

In Group I-1, Condition 2, procedures for staged evacuation of care recipients through a refuge area in an adjacent smoke compartment and then to an exterior assembly point.

Shall be amended or revised upon admission of any care recipients with unusual needs.

403.8.1.1.2 Fire safety plan. A copy of the fire safety plan shall be maintained at the facility at all times. The plans shall include the following in addition to the requirements of Section 404.2.2:

1. Location and number of care recipients sleeping rooms.
2. Location of special locking or egress control arrangements.

403.8.1.2 Staff training. Staff shall be periodically instructed and kept informed of their duties and responsibilities under the plan. Records of instruction shall be maintained. Such instruction shall be reviewed by staff at intervals not exceeding three months. Training of new staff shall be provided promptly upon entrance to duty.

Staff shall be instructed in the proper use of portable fire extinguishers and other manual fire suppression equipment.

403.8.1.3 Resident training. Residents capable of assisting in their own evacuation shall be trained in the proper actions to take in the event of a fire. In Group I-1, Condition 2 occupancies, training shall include evacuation through an adjacent smoke compartment and then to an exterior assembly point. The training shall include actions to take if the primary escape route is blocked. Residents shall be trained to assist each other in case of fire to the extent their physical and mental abilities permit them to do so without additional personal risk.

403.8.1.4 Drill frequency. In addition to the evacuation drills required in Section 405.2, staff shall participate in drills an additional two times a year on each shift. Twelve drills with all occupants shall be conducted in the first year of operation.

403.8.2 Group I-2 occupancies. Group I-2 occupancies shall comply with Sections 403.8.2.1 through 403.8.2.3.

403.8.2.1 Fire safety and evacuation plan. The fire safety and evacuation plans required by Section 404 shall include a description of special staff actions. The plans shall include all of the following in addition to the requirements of Section 404.

1. Procedures for evacuation for care recipients with needs for containment or restraint and post-evacuation containment, where present.
2. A written plan for maintenance of the means of egress.
3. Procedure for a defend-in-place strategy.
4. Procedures for a full-floor or building evacuation, where necessary.

In Group I-2, Condition 2, shall be amended or revised upon admission of any care recipients with unusual needs.

403.8.2.1.1 Fire safety plan. A copy of the plan shall be maintained at the facility at all times. Plans shall include all of the following in addition to the requirements of Section 404.2.2:

1. Location and number of care recipients sleeping rooms and operating rooms.
2. Location of special locking, ~~delayed egress or access control~~ arrangements.

403.8.2.2 Staff training. Staff shall be periodically instructed and kept informed of their duties and responsibilities under the plan. Records of instruction shall be maintained. Such instruction shall be reviewed by staff at intervals not exceeding three months. Training of new staff shall be provided promptly upon entrance to duty.

Staff shall be instructed in the proper use of portable fire extinguishers and other manual fire suppression equipment.

403.8.3 Group I-3 occupancies. Group I-3 occupancies shall comply with Sections 403.8.3.1 through 403.8.3.4.

403.8.3.1 Fire safety and evacuation plan. The fire safety and evacuation plans required by Section 404 shall include a description of special staff actions. Plans shall include all of the following in addition to the requirements of Section 404.

1. Procedures for evacuation for detainees with needs for containment or restraint and post-evacuation containment, where present.
2. Procedure for a defend-in-place strategy.
3. Procedures for a full-floor or building evacuation, where necessary.

403.8.3.1.1 Fire safety plan. A copy of the fire safety plan shall be maintained at the facility at all times. Plans shall include the following in addition to the requirements of Section 404.2.2:

1. Location and number of cells.
2. Location of special locking arrangements.

403.8.3.2 Staff training. Staff shall be periodically instructed and kept informed of their duties and responsibilities under the plan. Records of instruction shall be maintained. Such instruction shall be reviewed by staff at intervals not exceeding three months. Training of new staff shall be provided promptly upon entrance to duty.

Staff shall be instructed in the proper use of portable fire extinguishers and other manual fire suppression equipment.

403.8.3.3 Staffing. Group I-3 occupancies shall be provided with 24-hour staffing. A staff person shall be within three floors or 300 feet (91 440 mm) horizontal distance of the access door of each resident housing area. In Group I-3 Conditions 3, 4 and 5, as defined in Chapter 2, the arrangement shall be such that the staff involved can start release

of locks necessary for emergency evacuation or rescue and initiate other necessary emergency actions within 2 minutes of an alarm.

Exception: A staff person shall not be required to be within three floors or 300 feet (91 440 mm) horizontal distance of the access door of each resident housing area in areas in which all locks are unlocked remotely and automatically in accordance with Section 408.4 of the International Building Code.

403.8.3.4 Notification. Provisions shall be made for residents in Group I-3 Conditions 3, 4 and 5, as defined in Chapter 2, to readily notify staff of an emergency.

403.8.3.5 Keys. Keys necessary for unlocking doors installed in a means of egress shall be individually identifiable by both touch and sight.

403.10 Group R occupancies. Group R occupancies shall comply with Sections 403.10.1 through 403.10.3.6.

403.10.3 Group R-4 occupancies. An approved fire safety and evacuation plan in accordance with Section 404 shall be prepared and maintained for Group R-4 occupancies. Group R-4 occupancies shall comply with Sections 403.10.3.1 through 403.10.3.6.

403.10.3.1 Fire safety and evacuation plan. The fire safety and evacuation plan required by Section 404 shall include a description of special staff actions. The plans shall include the procedures necessary for full evacuation of care recipients, and shall be amended or revised upon admission of a care recipients with unusual needs.

403.10.3.1.1 Fire safety plan. A copy of the fire safety plan shall be maintained at the facility at all times. The plan shall include the following in addition to the requirements of Section 404.2.2:

1. Location and number of ~~resident~~ care recipients sleeping rooms.
2. Location of special locking or ~~egress control~~ arrangements.

403.10.3.2 Staff training. Staff shall be periodically instructed and kept informed of their duties and responsibilities under the plan. Records of instruction shall be maintained. Such instruction shall be reviewed by staff at intervals not exceeding three months. Training of new staff shall be provided promptly upon entrance to duty.

Staff shall be instructed in the proper use of portable fire extinguishers and other manual fire suppression equipment.

403.10.3.3 Resident training. Residents capable of assisting in their own evacuation shall be trained in the proper actions to take in the event of a fire. The training shall include actions to take if the primary escape route is blocked. Residents shall be trained to assist each other in case of fire to the extent their physical and mental abilities permit them to do so without additional personal risk.

403.10.3.4 Drill frequency. In addition to the evacuation drills required in Section 405.2, staff shall participate in drills an additional two times a year on each shift . Twelve drills with all occupants shall be conducted in the first year of operation.

SECTION 404

FIRE SAFETY, EVACUATION AND LOCKDOWN PLANS

404.3 Maintenance. Fire safety and evacuation plans and lockdown plans shall be reviewed or updated annually or as necessitated by changes in staff assignments, occupancy or the physical arrangement of the building.

404.4 Availability. Fire safety and evacuation plans and lockdown plans shall be available in the workplace for reference and review by employees, and copies shall be furnished to the fire code official for review on request.

404.4.1 Distribution. The fire safety and evacuation plans and lockdown plans shall be distributed to the tenants and building service employees by the owner or owner's agent. Tenants shall distribute to their employees applicable parts of the fire safety plan and lockdown plans affecting the employees' actions in the event of a fire or other emergency.

SECTION 405

EMERGENCY DRILLS

405.1 General. Emergency fire and evacuation drills complying with Sections 405.2 through 405.9 shall be conducted not less than annually where fire safety and evacuation plans are required by Section 403 or where required by the fire code official. Lockdown plan drills shall be conducted in accordance with the approved plan. Such drills shall not be substituted for fire and evacuation drills required by Section 405.2. Drills shall be designed in cooperation with the local authorities.

405.2 Occupant participation. Emergency fire and evacuation drills shall involve the actual evacuation of occupants to a selected assembly point and shall provide occupants with experience in exiting through all required exits. All required exits shall be used during emergency evacuation drills.

Exceptions:

In Ambulatory Care Facilities and Group I-2 the movement of care recipients to a safe area or to the exterior of the building is not required.

In Group I-1, Condition 2 the assembly point for residents is permitted to be within an adjacent smoke compartment.

In Group R-4, actual exiting from emergency escape and rescue openings shall not be required. Opening the emergency escape and rescue opening and signaling for help shall be an acceptable alternative.

In Group I-3, Conditions 2 through 5 where a defend-in-place response is permitted, the assembly point for detainees is permitted to be within an adjacent smoke compartment.

In Group I-3, Conditions 2 through 5, movement of detainees to an assembly point is not required where there are security concerns.

405.2 Frequency. Required emergency evacuation drills shall be held at the intervals specified in Table 405.2 or more frequently where necessary to familiarize all occupants with the drill procedure.

TABLE 405.2

FIRE AND EVACUATION DRILL FREQUENCY AND PARTICIPATION

□Insert table image

a. Emergency evacuation drills are required in Group B buildings required to have fire and safety evacuation plans in accordance with Section 403.4.

b. Emergency evacuation drills in Group R-2 college and university buildings shall be in accordance with Section 403.10.2.1. Other Group R-2 occupancies shall be in accordance with Section 403.10.2.2.

c. In Groups I-1 and R-4, see Section 403.8.1.4 and 403.10.3.4 for additional drills for staff.

405.3 Leadership. Responsibility for the planning and conduct of drills shall be assigned to competent persons designated to exercise leadership.

405.4 Time. Drills shall be held at unexpected times and under varying conditions to simulate the unusual conditions that occur in case of fire.

Exceptions:

In severe climates, the fire code official shall have the authority to modify the emergency evacuation drill termination points and frequency.

In Groups I-1, I-2, I-3 and R-4, where staff only emergency evacuation drills are conducted after visiting hours or where care recipients are expected to be asleep, a coded announcement shall be an acceptable alternative to audible alarms.

405.5 Record keeping. Records shall be maintained of required emergency evacuation drills and include the following information:

1. Identity of the person conducting the drill.
2. Date and time of the drill.
3. Notification method used.
4. Employees on duty and participating.
5. Number of occupants evacuated.
6. Special conditions simulated.
7. Problems encountered.
8. Weather conditions when occupants were evacuated.
9. Time required to accomplish complete evacuation.

405.6 Notification. Where required by the fire code official, prior notification of emergency evacuation drills shall be given to the fire code official.

405.7 Initiation. Where a fire alarm system is provided, emergency evacuation drills shall be initiated by activating the fire alarm system.

405.8 Accountability. As building occupants arrive at the assembly point, efforts shall be made to determine if all occupants have been successfully evacuated or have been accounted for.

Exception: In Group I-2 and ambulatory care facilities, the movement of care recipients to safe areas or to the exterior of the building is not required.

405.9 Recall and reentry. An electrically or mechanically operated signal used to recall occupants after an evacuation shall be separate and distinct from the signal used to initiate the evacuation. The recall signal initiation means shall be manually operated and under the control of the person in charge of the premises or the official in charge of the incident. Persons shall not reenter the premises until authorized to do so by the official in charge.

Group A	Quarterly	Employees
Group B ^a	Annually	All occupants
Group B (Ambulatory care facilities)	Quarterly on each shift	Staff
Group B ^b (Clinic, outpatient)	Annually	Staff
Group E	Monthly	All occupants
Group F	Annually	Employees
Group I-1 ^c	Semiannually on each shift	All occupants
Group I-2	Quarterly on each shift	Staff
Group I-3	Quarterly on each shift	Staff
Group I-4	Monthly on each shift	All occupants
Group R-1	Quarterly on each shift	Employees
Group R-2 ^d	Four annually	All occupants
Group R-4 ^e	Semiannually on each shift	All occupants

Cost Impact

The code change proposal will not increase or decrease the cost of construction .

These are operational requirements for emergency responders, resident and staff safety.

Internal ID: 638

F25-18

IFC: 403.3.1, 403.8.1.1, 403.8.1.1.1, 403.8.2.1, 403.8.3.1 (New), 403.10.3.1

Proponent: John Williams, Chair, representing Healthcare Committee (AHC@iccsafe.org); Michael O'Brian, Chair, representing FCAC (fcac@iccsafe.org)

2018 International Fire Code

Revise as follows:

403.3.1 Fire safety and evacuation plan. The fire safety and evacuation plan required by Section 404 shall include a description of special staff actions. This shall include procedures for stabilizing ~~patients~~care recipients in a defend-in-place response, staged evacuation, or full evacuation in conjunction with the entire building if part of a multitenant facility.

403.8.1.1 Fire safety and evacuation plan. The fire safety and evacuation plan required by Section 404 shall include ~~special employee actions, including fire protection procedures necessary for residents, and shall a description~~of special staff actions. Plans shall include all fo the following in addition to the requirements of Section 404.

1. Procedures for full evacuation of care recipients.
2. In Group I-1, Condition 2, procedures for staged evacuation of care recipients through a refuge area in an adjacent smoke compartment and then to an exterior assembly point.
3. Shall be amended or revised upon admission of any resident~~care recipient~~ with unusual needs.

Delete without substitution:

~~**403.8.1.1.1 Fire evacuation plan.** The fire evacuation plan required by Section 404 shall include a description of special staff actions. In addition to the requirements of Section 404, plans in Group I-1, Condition 2 occupancies shall include procedures for evacuation through a refuge area in an adjacent smoke compartment and then to an exterior assembly point.~~

403.8.2.1 Fire safety and evacuation plans, plan. The fire safety and evacuation plans required by Section 404 shall include a description of special staff *actions*. Plans shall include all of the following in addition to the requirements of Section 404.

1. Procedures for evacuation for ~~patients~~care recipients with needs for containment or restraint and post-evacuation containment, where present.
2. A written plan for maintenance of the means of egress.
3. Procedure for a defend-in-place strategy.
4. Procedures for a full-floor or building evacuation, where necessary.
5. In Group I-2, Condition 2, shall be amended or revised upon admission of any care recipients with unusual needs.

Add new text as follows:

403.8.3.1 Fire safety and evacuation plans.. The fire safety and evacuation plans required by Section 404 shall include a description of special staff actions. Plans shall include all of the following in addition to the requirements of Section 404.

1. Procedures for evacuation for detainees with needs for containment or restraint and post-evacuation containment, where present.
2. Procedure for a defend-in-place strategy.
3. Procedures for a full-floor or building evacuation, where necessary.

Revise as follows:

403.10.3.1 Fire safety and evacuation plan. The fire safety and evacuation plan required by Section 404 shall include ~~special employee actions, including fire protection~~a description of special staff actions. Plans shall include procedures necessary for residents~~full evacuation of care recipients~~, and shall be amended or revised upon admission of a residentcare recipients ~~with unusual needs.~~

Reason:

This is a series of proposal to coordinate the fire safety, evacuation and lock down plans between Groups I-1, I-2, I-3, R-4 and ambulatory care facilities. The FCAC and Healthcare committees worked together to address all situations where a staged evacuation or defend-in-place is utilized.

In Group I-1, Condition 2 and Group R-4, Condition 2 have separation, but this is a staged evacuation, not a defend-in place like a nursing home or hospital, therefore the items specific to defend in place are not included.

This proposal addresses consistent use of the term “employee” vs. “staff” because everyone in the building may not be an employee – example: doctors, interns, security – but still have responsibilities during an emergency. All patients and residents have been changed to care recipients to be consistent with the definitions for these types of facilities.

This proposal is submitted by the ICC Fire Code Action Committee (FCAC) and ICC Committee on Healthcare (CHC).

The FCAC was established by the ICC Board of Directors to pursue opportunities to improve and enhance assigned International Codes with regard to fire safety and hazardous materials in new and existing buildings and facilities and the protection of life and property in wildland urban interface areas. In 2017 the Fire-CAC has held 3 open meetings. In addition, there were numerous conference calls, Regional Work Group and Task Group meetings for the current code development cycle, which included members of the committees as well as any interested parties, to discuss and debate the proposed changes. Related documentation and reports are posted on the FCAC website at: <https://www.iccsafe.org/codes-tech-support/cs/fire-code-action-committee-fcac/>

The CHC was established by the ICC Board to evaluate and assess contemporary code issues relating to healthcare facilities. This is a joint effort between ICC and the American Society for Healthcare Engineering (ASHE), a subsidiary of the American Hospital Association, to eliminate duplication and conflicts in healthcare regulation. In 2017 the CHC held 2 open meetings and numerous conference calls, which included members of the committees as well as any interested parties, to discuss and debate the proposed changes. Information on the CHC, including: meeting agendas; minutes; reports; resource documents; presentations; and all other materials developed in conjunction with the CHC effort can be downloaded from the CHC website at: <https://www.iccsafe.org/codes-tech-support/cs/icc-committee-on-healthcare/>.

Cost Impact

The code change proposal will not increase or decrease the cost of construction .

These are operational requirements for emergency responders, resident and staff safety.

Internal ID: 643

F26-18

IFC: 403.3.2, 403.8.1.1.2, 403.8.2.2, 403.8.3.1 (New), 403.10.3.1.1

Proponent: John Williams, Chair, representing Healthcare Committee (AHC@iccsafe.org); Michael O'Brian, Chair, representing FCAC (fcac@iccsafe.org)

2018 International Fire Code

Revise as follows:

403.3.2 Fire safety plan. A copy of the fire safety plan shall be maintained at the facility at all times. The plan shall include all of the following in addition to the requirements of Section 404:

1. Locations of ~~patients-care recipients~~ who are rendered incapable of self-preservation.
2. Maximum number of ~~patients-care recipients~~ rendered incapable of self-preservation.
3. Area and extent of each ambulatory care facility.
4. ~~Location of adjacent smoke compartments or refuge areas, where required.~~
5. ~~Path of travel to adjacent smoke compartments.~~
6. Location of any special locking ~~, delayed egress or access control~~ arrangements.

403.8.1.1.2 Fire safety plans-plan. A copy of the fire safety plan shall be maintained at the facility at all times. ~~Plans-The plan~~ shall include the following in addition to the requirements of Section 404.2.2:

1. Location and number of ~~resident-care recipient~~ sleeping rooms.
2. Location of special locking or egress control arrangements.

403.8.2.2 Fire safety plans-plan. A copy of the plan shall be maintained at the facility at all times. ~~Plans-The plan~~ shall include all of the following in addition to the requirements of Section 404.2.2:

1. Location and number of ~~patient-care recipients~~ sleeping rooms and operating rooms.
2. ~~Location of adjacent smoke compartments or refuge areas.~~
3. ~~Path of travel to adjacent smoke compartments.~~
4. Location of special locking ~~, delayed egress or access control~~ arrangements.
5. ~~Location of elevators utilized for patient movement in accordance with the fire safety plan, where provided.~~

Add new text as follows:

403.8.3.1 Fire safety plan. A copy of the fire safety plan shall be maintained at the facility at all times. The plan shall include the following in addition to the requirements of Section 404.2.2:

1. Location and number of cells.
2. Location of special locking arrangements.

Revise as follows:

403.10.3.1.1 Fire safety plans. A copy of the fire safety plan shall be maintained at the facility at all times. ~~Plans-The plan~~ shall include the following in addition to the requirements of Section 404.2.2:

1. Location and number of ~~resident-care recipient~~ sleeping rooms.
2. Location of special locking ~~or egress control~~ arrangements.

Reason:

This is a series of proposal to coordinate the fire safety, evacuation and lock down plans between Groups I-1, I-2, I-3, R-4 and ambulatory care facilities. The FCAC and Healthcare committees worked together to address all situations where a staged evacuation or defend-in-place is utilized. See the proposal to IFC Section 403.3 for information on what these changes will look like if all pass.

Group I-1, Condition 2 includes smoke compartments. When looking at adding smoke compartments, refuge area and

path of travel, it was noted that this is already stated in 404.2.1 Item 1 and 404.2.2 Items 2.2 and 4.5. Therefore it is proposed to remove form Ambulatory care and Group I-2. Assisted evacuation is addressed in 404.2.1 Item 4 and 404.2.2 Item 2.3.

All patients and residents have been changed to care recipients to be consistent with the definitions for these types of facilities.

Last cycle there was a lot of work on the different locking systems. There should be a consistent and generic reference for these locking systems - "location of special locking arrangements". This will eliminate a laundry list and improve coordination over time as locking arrangements for ingress and egress are added.

This proposal is submitted by the ICC Fire Code Action Committee (FCAC) and the ICC Committee on Healthcare (CHC).

The FCAC was established by the ICC Board of Directors to pursue opportunities to improve and enhance assigned International Codes with regard to fire safety and hazardous materials in new and existing buildings and facilities and the protection of life and property in wildland urban interface areas. In 2017 the Fire-CAC has held 3 open meetings. In addition, there were numerous conference calls, Regional Work Group and Task Group meetings for the current code development cycle, which included members of the committees as well as any interested parties, to discuss and debate the proposed changes. Related documentation and reports are posted on the FCAC website at: <https://www.iccsafe.org/codes-tech-support/cs/fire-code-action-committee-fcac/>

The CHC was established by the ICC Board to evaluate and assess contemporary code issues relating to healthcare facilities. This is a joint effort between ICC and the American Society for Healthcare Engineering (ASHE), a subsidiary of the American Hospital Association, to eliminate duplication and conflicts in healthcare regulation. In 2017 the CHC held 2 open meetings and numerous conference calls, which included members of the committees as well as any interested parties, to discuss and debate the proposed changes. Information on the CHC, including: meeting agendas; minutes; reports; resource documents; presentations; and all other materials developed in conjunction with the CHC effort can be downloaded from the CHC website at: <https://www.iccsafe.org/codes-tech-support/cs/icc-committee-on-healthcare/>.

Cost Impact

The code change proposal will not increase or decrease the cost of construction .

These are operational requirements for emergency responders, resident and staff safety

Internal ID: 654

F27-18

IFC: 403.3.3, 403.8.1.2, 403.8.2.3 (New), 403.8.3.1, 403.8.3.2, 403.8.3.3, 403.10.3.2

Proponent: John Williams, Chair, representing Healthcare Committee (AHC@iccsafe.org); Michael O'Brian, Chair, representing FCAC (fcac@iccsafe.org)

2018 International Fire Code

Revise as follows:

403.3.3 Staff training. ~~Employees-Staff~~ shall be periodically instructed and kept informed of their duties and responsibilities under the plan. Records of instruction shall be maintained. Such instruction shall be reviewed by the staff ~~not less than every two months. A copy of the plan shall be readily available at all times within the facility.~~ at intervals not exceeding three months. Training of new staff shall be provided promptly upon entrance to duty. Staff shall be instructed in the proper use of portable fire extinguishers and other manual fire suppression equipment.

403.8.1.2 Employee-Staff training. ~~Employees-Staff~~ shall be periodically instructed and kept informed of their duties and responsibilities under the plan. Records of instruction shall be maintained. Such instruction shall be reviewed by ~~employees-staff~~ at intervals not exceeding ~~two-three~~ months. ~~A copy of the plan shall be readily available at all times within the facility.~~ Training of new staff shall be provided promptly upon entrance to duty. Staff shall be instructed in the proper use of portable fire extinguishers and other manual fire suppression equipment.

Add new text as follows:

403.8.2.3 Staff training. Staff shall be periodically instructed and kept informed of their duties and responsibilities under the plan. Records of instruction shall be maintained. Such instruction shall be reviewed by staff at intervals not exceeding three months. Training of new staff shall be provided promptly upon entrance to duty. Staff shall be instructed in the proper use of portable fire extinguishers and other manual fire suppression equipment.

Revise as follows:

403.8.3.1 Employee-Staff training. ~~Employees-Staff~~ shall be instructed in the proper use of portable fire extinguishers and other manual fire suppression equipment. Training of new employees periodically instructed and kept informed of their duties and responsibilities under the plan. Records of instruction shall be maintained. Such instruction shall be reviewed by staff at intervals not exceeding three months. Training of new staff shall be provided promptly upon entrance to duty. Refresher training shall be provided not less than annually. Staff shall be instructed in the proper use of portable fire extinguishers and other manual fire suppression equipment.

403.8.3.2 Employee-staffing-Staffing. ~~Group I-3 occupancies shall be provided with 24-hour staffing. An employee-A staff person~~ shall be within three floors or 300 feet (91 440 mm) horizontal distance of the access door of each resident housing area. In Group I-3 Conditions 3, 4 and 5, as defined in Chapter 2, the arrangement shall be such that the ~~employee-staff~~ involved can start release of locks necessary for emergency evacuation or rescue and initiate other necessary emergency actions within 2 minutes of an alarm.

Exception: ~~An employee-A staff person~~ shall not be required to be within three floors or 300 feet (91 440 mm) horizontal distance of the access door of each resident housing area in areas in which all locks are unlocked remotely and automatically in accordance with Section 408.4 of the International Building Code.

403.8.3.3 Notification. Provisions shall be made for residents in Group I-3 Conditions 3, 4 and 5, as defined in Chapter 2, to readily notify ~~an employee-staff~~ of an emergency.

403.10.3.2 Employee-Staff training. ~~Employees-Staff~~ shall be periodically instructed and kept informed of their duties and responsibilities under the plan. Records of instruction shall be maintained. Such instruction shall be reviewed by ~~employees-staff~~ at intervals not exceeding ~~two-three~~ months. ~~A copy of the plan shall be readily available at all times within the facility.~~ Training of new staff shall be provided promptly upon entrance to duty. Staff shall be instructed in the proper use of portable fire extinguishers and other manual fire suppression equipment.

Reason:

This is a series of proposal to coordinate the fire safety, evacuation and lock down plans between Groups I-1, I-2, I-3, R-4 and ambulatory care facilities. The FCAC and Healthcare committees worked together to address all situations where a staged evacuation or defend-in-place is utilized. See the proposal to IFC Section 403.3 for information on what

these changes will look like if all pass.

The criteria is not consistent is using the term “employee” or “staff”. Consistent use of the term “employee” vs. “staff” because everyone in the building may not be an employee – example: doctors, interns, security – but still have responsibilities during an emergency.

It is important for employees within these facilities to be trained, including training for new employees and review of the plan. The language is revised to be consistent, and added to Group I-2 and I-3. Currently ambulatory care facilities, Group I-1 and R-4 requires review of the evacuation plans every two months. If the review is every three months, the fire drills required can be considered part of the review. The current requirement is not clear on what would meet the requirements and we could find no technical justification for the two months.

The sentence about a copy of the plan being available is deleted because it is already stated in Section 404.4.

Where fire extinguishers are provided, the staff should be trained in their use.

This proposal is submitted by the ICC Fire Code Action Committee (FCAC) and the ICC Committee on Healthcare (CHC).

The FCAC was established by the ICC Board of Directors to pursue opportunities to improve and enhance assigned International Codes with regard to fire safety and hazardous materials in new and existing buildings and facilities and the protection of life and property in wildland urban interface areas. In 2017 the Fire-CAC has held 3 open meetings. In addition, there were numerous conference calls, Regional Work Group and Task Group meetings for the current code development cycle, which included members of the committees as well as any interested parties, to discuss and debate the proposed changes. Related documentation and reports are posted on the FCAC website at: <https://www.iccsafe.org/codes-tech-support/cs/fire-code-action-committee-fcac/>

The CHC was established by the ICC Board to evaluate and assess contemporary code issues relating to healthcare facilities. This is a joint effort between ICC and the American Society for Healthcare Engineering (ASHE), a subsidiary of the American Hospital Association, to eliminate duplication and conflicts in healthcare regulation. In 2017 the CHC held 2 open meetings and numerous conference calls, which included members of the committees as well as any interested parties, to discuss and debate the proposed changes. Information on the CHC, including: meeting agendas; minutes; reports; resource documents; presentations; and all other materials developed in conjunction with the CHC effort can be downloaded from the CHC website at: <https://www.iccsafe.org/codes-tech-support/cs/icc-committee-on-healthcare/>.

Cost Impact

The code change proposal will not increase or decrease the cost of construction .

These are operational requirements for emergency responders, resident and staff safety so will not affect construction costs.

Internal ID: 677

F28-18

IFC: 403.3.4, 403.8.1.6, 403.8.2.3, 403.10.3.6, 405.1, 405.2 (New)

Proponent: John Williams, Chair, representing Healthcare Committee (AHC@iccsafe.org); Michael O'Brian, Chair, representing FCAC (fcac@iccsafe.org)

2018 International Fire Code

Delete without substitution:

~~403.3.4 Emergency evacuation drills.~~ Emergency evacuation drills shall comply with Section 405.

~~Exception:~~ The movement of patients to safe areas or to the exterior of the building is not required.

~~403.8.1.6 Resident participation in drills.~~ Emergency evacuation drills shall involve the actual evacuation of residents to a selected assembly point and shall provide residents with experience in exiting through all required exits. All required exits shall be used during emergency evacuation drills.

Revise as follows:

403.8.2.3 Emergency evacuation drills. Emergency evacuation drills shall comply with Section 405.

Exceptions Exception:

- ~~1. The movement of patients to safe areas or to the exterior of the building is not required.~~
- ~~2. Where emergency evacuation drills are conducted after visiting hours or where patients or residents are expected to be asleep, a coded announcement shall be an acceptable alternative to audible alarms.~~

Delete without substitution:

~~403.10.3.6 Resident participation in drills.~~ Emergency evacuation drills shall involve the actual evacuation of residents to a selected assembly point and shall provide residents with experience in exiting through all required exits. All required exits shall be used during emergency evacuation drills.

~~Exception:~~ Actual exiting from emergency escape and rescue windows shall not be required. Opening the emergency escape and rescue window and signaling for help shall be an acceptable alternative.

Revise as follows:

405.1 General. Emergency fire and evacuation drills complying with Sections 405.2 through 405.9 shall be conducted not less than annually where fire safety and evacuation plans are required by Section 403 or where required by the *fire code official*. Drills shall be designed in cooperation with the local authorities.

Add new text as follows:

405.2 Occupant participation. Emergency fire and evacuation drills shall involve the actual evacuation of occupants to a selected assembly point and shall provide occupants with experience in exiting through all required exits. All required exits shall be used during emergency evacuation drills.

Exceptions:

1. In Ambulatory Care Facilities and Group I-2 the movement of care recipients to a safe area or to the exterior of the building is not required.
2. In Group I-1, Condition 2 the assembly point for residents is permitted to be within an adjacent smoke compartment.
3. In Group R-4, actual exiting from emergency escape and rescue openings shall not be required. Opening the emergency escape and rescue opening and signaling for help shall be an acceptable alternative.
4. In Group I-3, Conditions 2 through 5 where a defend-in-place response is permitted, the assembly point for detainees is permitted to be within an adjacent smoke compartment.

5. In Group I-3, Conditions 2 through 5, movement of detainees is not required to an assembly point is not required where there are security concerns.

Reason:

This is a series of proposal to coordinate the fire safety, evacuation and lock down plans between Groups I-1, I-2, I-3, R-4 and ambulatory care facilities. The FCAC and Healthcare committees worked together to address all situations where a staged evacuation or defend-in-place is utilized. See the proposal to IFC Section 403.3 for information on what these changes will look like if all pass.

The requirements for drills in Section 405 never really say where you move to during a drill. It is only implied in IFC 405.8 when it mentions accountability at assembly points.

How to leave and get to an assembly point is stated for Group I-1 and R-4, but does not recognize the new requirements for smoke compartments in Group I-1, Condition 2. It is implied by the exceptions in ambulatory care and Group I-2 that drills are for moving to smoke compartments by having exception for movement of patients in beds. This should be stated at the beginning of the drill requirements for all facilities.

The exceptions for drills should be in the drill section specifically. The exceptions could stay in the specific requirements, but only if Section 405 included a description of what was supposed to happen for drills, otherwise the reference to Section 405 does not make sense.

Exception 4 ad 5 are in recognition of detainee participation in drills for jails.

Note: If both exceptions to 403.8.2.3 are removed (exception 1 is addressed under a different proposal), the whole section is redundant text and should be removed.

This proposal is submitted by the ICC Fire Code Action Committee (FCAC) and the ICC Committee on Healthcare (CHC).

The FCAC was established by the ICC Board of Directors to pursue opportunities to improve and enhance assigned International Codes with regard to fire safety and hazardous materials in new and existing buildings and facilities and the protection of life and property in wildland urban interface areas. In 2017 the Fire-CAC has held 3 open meetings. In addition, there were numerous conference calls, Regional Work Group and Task Group meetings for the current code development cycle, which included members of the committees as well as any interested parties, to discuss and debate the proposed changes. Related documentation and reports are posted on the FCAC website at: <https://www.iccsafe.org/codes-tech-support/cs/fire-code-action-committee-fcac/>

The CHC was established by the ICC Board to evaluate and assess contemporary code issues relating to healthcare facilities. This is a joint effort between ICC and the American Society for Healthcare Engineering (ASHE), a subsidiary of the American Hospital Association, to eliminate duplication and conflicts in healthcare regulation. In 2017 the CHC held 2 open meetings and numerous conference calls, which included members of the committees as well as any interested parties, to discuss and debate the proposed changes. Information on the CHC, including: meeting agendas; minutes; reports; resource documents; presentations; and all other materials developed in conjunction with the CHC effort can be downloaded from the CHC website at: <https://www.iccsafe.org/codes-tech-support/cs/icc-committee-on-healthcare/>.

Cost Impact

The code change proposal will not increase or decrease the cost of construction .

These are operational requirements for emergency responders, resident and staff safety and will not affect construction costs.

Internal ID: 688

F29-18

IFC: 403.7.1, 403.7.1.1, 403.7.1.2, 403.7.1.3, 403.7.1.4

Proponent: Joe McElvaney, representing self (joe.mcelvaney@gmail.com)

2018 International Fire Code

Revise as follows:

403.7.1 Group H-5 occupancies. Emergency plan. ~~An emergency plan shall be established for Group H-5 occupancies shall comply in accordance with Sections 403.7.1.1 through 403.7.1.4.~~

403.7.1.1 Plans and diagrams. In addition to the requirements of Section 404 and Section 407.6, plans and diagrams shall be maintained in approved locations indicating the approximate plan for each area, the amount and type of ~~HPM hazardous material's~~ stored, handled and used, locations of shutoff valves for ~~HPM hazardous materials~~ supply piping, emergency telephone locations and locations of exits.

403.7.1.2 Plan updating. The plans and diagrams required by Sections 404, 403.7.1.1 and 407.6 shall be maintained up to date and the *fire code official* and fire department shall be informed of major changes.

403.7.1.3 Emergency response team. Responsible persons shall be designated as an on-site emergency response team and trained to be liaison personnel for the fire department. These persons shall aid the fire department in ~~preplanning pre-planning~~ emergency responses, identifying locations where ~~HPM is hazardous materials are stored~~, handled and used, and be familiar with the chemical nature of such material. An adequate number of personnel for each work shift shall be designated.

403.7.1.4 Emergency drills. Emergency drills of the on-site emergency response team shall be conducted on a regular basis but not less than once every three months. Records of drills conducted shall be maintained.

Reason:

The current code allow requires plans and emergency response team/liasion person and drills for H-5 occupancies. this proposal would now required these items within section 403.7.1.1 - 403.7.1.4 for all H occupancies.

These H occupancies are high hazard occupancies that have a direct impact to the employees working in a H occupancies, the public and the first responders. By having these requirements would could say that life and property loss may be reduce if an event s would occur by having these plans and emergency response teams/liasion person.

One should remember that H-1 are those site that can have a detonation, H-2 are those site that can have a deflagration or accelerated burning, H-3 are those sate that have physical hazards, H-4 are those site that have health hazards.

All these H occupancies exceed the MAQ for the Physical and/or Health hazard and the number of control areas allowed by the fire code.

Cost Impact

The code change proposal will increase the cost of construction .

The current code only requires this information and response team/liasion person for H- 5 occupancies which are semiconductor fabrication facilities.

This code change would require this to all H occupancies that have exceeded the allow amount of physical and /or health hazards and the number of control areas allowed by the fire code.

This cost should be small since these occupancies should have plans and diagrams of theirs site and new item's for them would be drills and emergency response team/liasion person

Internal ID: 769

F30-18

IFC: 403.8.1.3, 403.10.3.3

Proponent: John Williams, Chair, representing Healthcare Committee (AHC@iccsafe.org); Michael O'Brian, Chair, representing FCAC (fcac@iccsafe.org)

2018 International Fire Code

Revise as follows:

403.8.1.3 Resident training. Residents capable of assisting in their own evacuation shall be trained in the proper actions to take in the event of a fire. In Group I-1, Condition 2 occupancies, training shall include evacuation through an adjacent smoke compartment and then to an exterior assembly point. The training shall include actions to take if the primary escape route is blocked. ~~Where the resident is given rehabilitation or habilitation training, methods of fire prevention and actions to take in the event of a fire shall be a part of the rehabilitation training program.~~ Residents shall be trained to assist each other in case of fire to the extent their physical and mental abilities permit them to do so without additional personal risk.

403.10.3.3 Resident training. Residents capable of assisting in their own evacuation shall be trained in the proper actions to take in the event of a fire. The training shall include actions to take if the primary escape route is blocked. ~~Where the resident is given rehabilitation or habilitation training, methods of fire prevention and actions to take in the event of a fire shall be a part of the rehabilitation training program.~~ Residents shall be trained to assist each other in case of fire to the extent their physical and mental abilities permit them to do so without additional personal risk.

Reason:

This is a series of proposal to coordinate the fire safety, evacuation and lock down plans between Groups I-1, I-2, I-3, R-4 and ambulatory care facilities. The FCAC and Healthcare committees worked together to address all situations where a staged evacuation or defend-in-place is utilized. See the proposal to IFC Section 403.3 for information on what these changes will look like if all pass.

The sentence proposed to be struck is unclear as to application. It is ineffective to train someone for something outside of the environment they are in.

This proposal is submitted by the ICC Fire Code Action Committee (FCAC) and the ICC Committee on Healthcare (CHC).

The FCAC was established by the ICC Board of Directors to pursue opportunities to improve and enhance assigned International Codes with regard to fire safety and hazardous materials in new and existing buildings and facilities and the protection of life and property in wildland urban interface areas. In 2017 the Fire-CAC has held 3 open meetings. In addition, there were numerous conference calls, Regional Work Group and Task Group meetings for the current code development cycle, which included members of the committees as well as any interested parties, to discuss and debate the proposed changes. Related documentation and reports are posted on the FCAC website at: <https://www.iccsafe.org/codes-tech-support/cs/fire-code-action-committee-fcac/>

The CHC was established by the ICC Board to evaluate and assess contemporary code issues relating to healthcare facilities. This is a joint effort between ICC and the American Society for Healthcare Engineering (ASHE), a subsidiary of the American Hospital Association, to eliminate duplication and conflicts in healthcare regulation. In 2017 the CHC held 2 open meetings and numerous conference calls, which included members of the committees as well as any interested parties, to discuss and debate the proposed changes. Information on the CHC, including: meeting agendas; minutes; reports; resource documents; presentations; and all other materials developed in conjunction with the CHC effort can be downloaded from the CHC website at: <https://www.iccsafe.org/codes-tech-support/cs/icc-committee-on-healthcare/>.

Cost Impact

The code change proposal will not increase or decrease the cost of construction .

This is a deletion of a requirement for resident training therefore the cost of compliance will not increase.

Internal ID: 680

F31-18

IFC: 403.8.1.4, 403.10.3.4, 405.2, TABLE 405.2

Proponent: John Williams, Chair, representing Healthcare Committee (AHC@iccsafe.org); Michael O'Brian, Chair, representing FCAC (fcac@iccsafe.org)

2018 International Fire Code

403.8.1.4 Drill frequency. In addition to the evacuation drills required in Section 405.2, ~~employees-staff~~ shall participate in drills an additional two times a year on each shift. Twelve drills with all occupants shall be conducted in the first year of operation. Drills are not required to comply with the time requirements of Section 405.4.

403.10.3.4 Drill frequency. In addition to the evacuation drills required in Section 405.2, ~~employees-staff~~ shall participate in drills an additional two times a year on each shift. Twelve drills with all occupants shall be conducted in the first year of operation.

405.2 Frequency. Required emergency evacuation drills shall be held at the intervals specified in Table 405.2 or more frequently where necessary to familiarize all occupants with the drill procedure.

**TABLE 405.2
FIRE AND EVACUATION DRILL FREQUENCY AND PARTICIPATION**

GROUP OR OCCUPANCY	FREQUENCY	PARTICIPATION
Group A	Quarterly	Employees-Staff
Group B ^b	Annually	All occupants
Group B ^c (Ambulatory care facilities)	Quarterly on each shift ^a	Employees-Staff
Group B ^b (Clinic, outpatient)	Annually	Employees-Staff
Group E	Monthly ^a	All occupants
Group F	Annually	Employees
Group I-1	Semiannually on each shift ^a	All occupants
Group I-2	Quarterly on each shift ^a	Employees-Staff
Group I-3	Quarterly on each shift ^a	Employees-Staff
Group I-4	Monthly on each shift ^a	All occupants
Group R-1	Quarterly on each shift	Employees
Group R-2 ^d	Four annually	All occupants
Group R-4	Semiannually on each shift ^a	All occupants

- a. In severe climates, the fire code official shall have the authority to modify the emergency evacuation drill frequency.
- b. Emergency evacuation drills are required in Group B buildings required to have fire and safety evacuation plans in accordance with Section 403.4.
- c. Emergency evacuation drills are required in ambulatory care facilities in accordance with Section 403.3.
- d. Emergency evacuation drills in Group R-2 college and university buildings shall be in accordance with Section 403.10.2.1. Other Group R-2 occupancies shall be in accordance with Section 403.10.2.2.
- e. In Groups I-1 and R-4, see Section 403.8.1.4 and 403.10.3.4 for additional drills for staff.

Reason:

This is a series of proposal to coordinate the fire safety, evacuation and lock down plans between Groups I-1, I-2, I-3, R-4 and ambulatory care facilities. The FCAC and Healthcare committees worked together to address all situations where a staged evacuation or defend-in-place is utilized. See the proposal to IFC Section 403.3 for information on what these changes will look like if all pass.

In healthcare facilities, often doctors, interns or nurses are by contract – so they are not all employees. However, they must be trained and act during any emergencies. Therefore, the term staff is more relevant than employees. Footnotes are added for Group I-1 and R-4 so that there is a pointer for additional drills required for staff only.

Group B – In footnote b, the reference back to fire and safety evacuation plans will keep the same threshold for requirements, and will reduce the chance that over time the numbers could be changed in one place and not the other.

This proposal is submitted by the ICC Fire Code Action Committee (FCAC) and the ICC Committee on Healthcare (CHC).

The FCAC was established by the ICC Board of Directors to pursue opportunities to improve and enhance assigned International Codes with regard to fire safety and hazardous materials in new and existing buildings and facilities and the protection of life and property in wildland urban interface areas. In 2017 the Fire-CAC has held 3 open meetings. In addition, there were numerous conference calls, Regional Work Group and Task Group meetings for the current code development cycle, which included members of the committees as well as any interested parties, to discuss and debate the proposed changes. Related documentation and reports are posted on the FCAC website at: <https://www.iccsafe.org/codes-tech-support/cs/fire-code-action-committee-fcac/>

The CHC was established by the ICC Board to evaluate and assess contemporary code issues relating to healthcare facilities. This is a joint effort between ICC and the American Society for Healthcare Engineering (ASHE), a subsidiary of the American Hospital Association, to eliminate duplication and conflicts in healthcare regulation. In 2017 the CHC held 2 open meetings and numerous conference calls, which included members of the committees as well as any interested parties, to discuss and debate the proposed changes. Information on the CHC, including: meeting agendas; minutes; reports; resource documents; presentations; and all other materials developed in conjunction with the CHC effort can be downloaded from the CHC website at: <https://www.iccsafe.org/codes-tech-support/cs/icc-committee-on-healthcare/>.

Cost Impact

The code change proposal will not increase or decrease the cost of construction .

These are operational requirements for emergency responders, resident and staff safety and will not affect the cost of construction.

Internal ID: 682

F32-18

IFC: 403.8.1.4, 403.8.1.5, 403.8.1.7, 403.8.2.3, 403.10.3.5, 405.2, TABLE 405.2, 405.4, 405.8

Proponent: John Williams, Chair, representing Healthcare Committee (AHC@iccsafe.org); Michael O'Brian, Chair, representing FCAC (fcac@iccsafe.org)

2018 International Fire Code

Revise as follows:

403.8.1.4 Drill frequency. In addition to the evacuation drills required in Section 405.2, employees shall participate in drills an additional two times a year on each shift. Twelve drills with all occupants shall be conducted in the first year of operation. ~~Drills are not required to comply with the time requirements of Section 405.4.~~

Delete without substitution:

~~**403.8.1.5 Drill times.** Drill times are not required to comply with Section 405.4.~~

~~**403.8.1.7 Emergency evacuation drill deferral.** In severe climates, the *fire code official* shall have the authority to modify the emergency evacuation drill frequency specified in Section 405.2.~~

Revise as follows:

403.8.2.3 Emergency evacuation drills. Emergency evacuation drills shall comply with Section 405.

Exceptions Exception:

1. The movement of patients to safe areas or to the exterior of the building is not required.
2. ~~Where emergency evacuation drills are conducted after visiting hours or where patients or residents are expected to be asleep, a coded announcement shall be an acceptable alternative to audible alarms.~~

Delete without substitution:

~~**403.10.3.5 Drill times.** Drill times are not required to comply with Section 405.4.~~

405.2 Frequency. Required emergency evacuation drills shall be held at the intervals specified in Table 405.2 or more frequently where necessary to familiarize all occupants with the drill procedure.

Revise as follows:

**TABLE 405.2
FIRE AND EVACUATION DRILL FREQUENCY AND PARTICIPATION**

GROUP OR OCCUPANCY	FREQUENCY	PARTICIPATION
Group A	Quarterly	Employees
Group B ^b	Annually	All occupants
Group B ^c (Ambulatory care facilities)	Quarterly on each shift ^a	Employees
Group B ^b (Clinic, outpatient)	Annually	Employees
Group E	Monthly ^a	All occupants
Group F	Annually	Employees
Group I-1	Semiannually on each shift ^a	All occupants
Group I-2	Quarterly on each shift ^a	Employees
Group I-3	Quarterly on each shift ^a	Employees
Group I-4	Monthly on each shift ^a	All occupants
Group R-1	Quarterly on each shift	Employees
Group R-2 ^d	Four annually	All occupants
Group R-4	Semiannually on each shift ^a	All occupants

- ~~a. In severe climates, the fire code official shall have the authority to modify the emergency evacuation drill frequency.~~
- ~~b. a. Emergency evacuation drills are required in Group B buildings having an occupant load of 500 or more persons or more than 100 persons above or below the lowest level of exit discharge.~~
- ~~c. Emergency evacuation drills are required in ambulatory care facilities in accordance with Section 403.3.~~
- ~~d. b. Emergency evacuation drills in Group R-2 college and university buildings shall be in accordance with Section 403.10.2.1. Other Group R-2 occupancies shall be in accordance with Section 403.10.2.2.~~

405.4 Time. Drills shall be held at unexpected times and under varying conditions to simulate the unusual conditions that occur in case of fire.

Exceptions:

1. In severe climates, the fire code official shall have the authority to modify the emergency evacuation drill termination points and frequency.
2. In Groups I-1, I-2, I-3 and R-4, where staff only emergency evacuation drills are conducted after visiting hours or where care recipients are expected to be asleep, a coded announcement shall be an acceptable alternative to audible alarms.

405.8 Accountability. As building occupants arrive at the assembly point, efforts shall be made to determine if all occupants have been successfully evacuated or have been accounted for.

Exception: In Group I-2 and ambulatory care facilities, the movement of care recipients to safe areas or to the exterior of the building is not required.

Reason:

There are no technical changes, this is a reorganization. This is a series of proposal to coordinate the fire safety, evacuation and lock down plans between Groups I-1, I-2, I-3, R-4 and ambulatory care facilities. The FCAC and Healthcare committees worked together to address all situations where a staged evacuation or defend-in-place is utilized. See the proposal to IFC Section 403.3 for information on what these changes will look like if all pass.

Group I-1 and R-4 allow for the timing to not be “unexpected time and under varying conditions”. We believe this was to not startle patients at night while they are sleeping. However, both types of facilities require additional drills for staff at all shifts. It seems more appropriate to follow the exception under Group I-2, Exception 2 as well as also allow this for jails.

The exception for severe weather is stated only for Group I-1, in Section 403.8.1.7. However, Table 405 foot note a, allows the fire department to make a similar call for Ambulatory Care, Group E, all Group I-1 and R-4. It seems more appropriate just to make a general statement in Section 405.2 since the fire department could always make this call for any drill.

Section 403.8.2.3 Exception 1 is addressed in another proposal. If both proposal's are accepted, this section can be deleted. The reference in the main text to Section 405 if redundant.

This proposal is submitted by the ICC Fire Code Action Committee (FCAC) and the ICC Committee on Healthcare (CHC).

The FCAC was established by the ICC Board of Directors to pursue opportunities to improve and enhance assigned International Codes with regard to fire safety and hazardous materials in new and existing buildings and facilities and the protection of life and property in wildland urban interface areas. In 2017 the Fire-CAC has held 3 open meetings. In addition, there were numerous conference calls, Regional Work Group and Task Group meetings for the current code development cycle, which included members of the committees as well as any interested parties, to discuss and debate the proposed changes. Related documentation and reports are posted on the FCAC website at: <https://www.iccsafe.org/codes-tech-support/cs/fire-code-action-committee-fcac/>

The CHC was established by the ICC Board to evaluate and assess contemporary code issues relating to healthcare facilities. This is a joint effort between ICC and the American Society for Healthcare Engineering (ASHE), a subsidiary of the American Hospital Association, to eliminate duplication and conflicts in healthcare regulation. In 2017 the CHC held 2 open meetings and numerous conference calls, which included members of the committees as well as any interested parties, to discuss and debate the proposed changes. Information on the CHC, including: meeting agendas; minutes; reports; resource documents; presentations; and all other materials developed in conjunction with the CHC effort can be downloaded from the CHC website at: <https://www.iccsafe.org/codes-tech-support/cs/icc-committee-on-healthcare/>.

Cost Impact

The code change proposal will not increase or decrease the cost of construction .

These are operational requirements for emergency responders, resident and staff safety therefore will not affect the cost of construction.

Internal ID: 685

F33-18

IFC: 403.8.2.4 (New)

Proponent: John Williams, Chair, representing Healthcare Committee (AHC@iccsafe.org)

2018 International Fire Code

Add new text as follows:

403.8.2.4 Fire loss prevention in operating rooms. Fire protection features and procedures for fire loss prevention in surgical operating rooms shall comply with NFPA 99, Section 15.13.

Reason:

Adding a reference to NFPA 99 for fire loss prevention in operating rooms ensure capturing the intent of the concepts to be used in this setting. These concepts outlined in the reference document describe material and source segregation. Specific reference to 'fire loss prevention' in the proposed sentence makes the purpose of the requirement clearer. Operating rooms are subject to potential fires if flammable materials are exposed to accelerants ignited by cautery or surgical procedures. NFPA 99 is the standard for systems and procedures to be used in I-2, Condition 2 hospitals. Chapter 4 of the IFC is the appropriate location to address fire prevention in this setting. This code change is proposed to align with federal standards (K933).

This proposal is submitted by the ICC Committee on Healthcare (CHC). The CHC was established by the ICC Board to evaluate and assess contemporary code issues relating to healthcare facilities. This is a joint effort between ICC and the American Society for Healthcare Engineering (ASHE), a subsidiary of the American Hospital Association, to eliminate duplication and conflicts in healthcare regulation. In 2017 the CHC held 2 open meetings and numerous conference calls, which included members of the committees as well as any interested parties, to discuss and debate the proposed changes. Information on the CHC, including: meeting agendas; minutes; reports; resource documents; presentations; and all other materials developed in conjunction with the CHC effort can be downloaded from the CHC website at: <https://www.iccsafe.org/codes-tech-support/cs/icc-committee-on-healthcare/>.

Cost Impact

The code change proposal will increase the cost of construction .

This may require additional fire protection devices in operating rooms for patient safety. However, it does not add cost to the healthcare industry because we already follow these requirements in the context of the federal standard.

Internal ID: 699

F34-18

IFC: 403.10.2.3

Proponent: William Freer, New York State Office of Fire Prevention and Control, representing New York State Office of Fire Prevention and Control (wfreer@dhses.ny.gov)

2018 International Fire Code

Revise as follows:

403.10.2.3 Evacuation diagrams for dormitories. A diagram depicting two evacuation routes shall be posted on or immediately adjacent to every required egress door from each dormitory *sleeping or dwelling unit*. Evacuation diagrams shall be reviewed and updated as needed to maintain accuracy.

Reason:

This code change is to help clarify the requirement for purposes of compliance and enforcement. The current code states uses the term sleeping unit but doesn't take into account that many dormitories now include dwelling units as well. Based on the definition of sleeping unit, it is confusing whether or not evacuation diagrams would be required in suite style dormitories and therefore not consistently applied.

This change will also allow the code enforcement official the ability to require the diagram on the door to the corridor as compared to the door from the sleeping unit.

Cost Impact

The code change proposal will decrease the cost of construction .

This code proposal may decrease the cost of construction where a diagram is required at the dwelling unit door as compared to the sleeping unit door, less diagrams would be required.

Internal ID: 1057

F35-18

IFC: 403.10.3.6

Proponent: Michael O'Brian, Chair, representing FCAC (fcac@iccsafe.org)

2018 International Fire Code

Revise as follows:

403.10.3.6 Resident participation in drills. Emergency evacuation drills shall involve the actual evacuation of residents to a selected assembly point and shall provide residents with experience in exiting through all required exits. All required exits shall be used during emergency evacuation drills.

Exception: Actual exiting from emergency escape and rescue ~~windows-openings~~ shall not be required. Opening the emergency escape and rescue ~~window-openings~~ and signaling for help shall be an acceptable alternative.

Reason:

This is one of a series of 11 proposals to coordinate the Emergency Escape and Rescue Openings (EERO) technical criteria in the I-codes. Please see the proposal for the definition of Emergency Escape and Rescue Openings for additional information.

This section is only applicable under fire and safety plans for Group R-4. IFC 403.10.3.6 says "window" instead of opening. This should be revised to use the defined term. This also addresses situations such as balcony doors instead of windows.

This proposal is submitted by the ICC Fire Code Action Committee (FCAC). The FCAC was established by the ICC Board of Directors to pursue opportunities to improve and enhance assigned International Codes with regard to fire safety and hazardous materials in new and existing buildings and facilities and the protection of life and property in wildland urban interface areas. In 2017 the Fire-CAC has held 3 open meetings. In addition, there were numerous conference calls, Regional Work Group and Task Group meetings for the current code development cycle, which included members of the committees as well as any interested parties, to discuss and debate the proposed changes. Related documentation and reports are posted on the FCAC website at: <https://www.iccsafe.org/codes-tech-support/cs/fire-code-action-committee-fcac/>

Cost Impact

The code change proposal will not increase or decrease the cost of construction .

This proposal addresses an operational/practice drill and is not a construction requirement.

Internal ID: 456

F36-18

IFC: 403.12.2, 403.12.3.1, 403.12.3.3

Proponent: Richard Nix, representing Entertainment Services & Technology Association/Event Safety Alliance (rnix@zoomtown.com)

2018 International Fire Code

Revise as follows:

403.12.2 Public safety plan for gatherings. Where the *fire code official* determines that an indoor or outdoor gathering of persons has an adverse impact on public safety through diminished access to buildings, structures, fire hydrants and fire apparatus access roads or where such gatherings adversely affect public safety services of any kind, the *fire code official* shall have the authority to order the development of or prescribe a public safety plan that provides an *approved* level of public safety and addresses the following items:

1. Emergency vehicle ingress and egress.
2. Fire protection.
3. Emergency egress or escape routes.
4. Emergency medical services.
5. Public assembly areas.
6. The directing of both attendees and vehicles, including the parking of vehicles.
7. Vendor and food concession distribution.
8. The need for the presence of law enforcement.
9. The need for fire and emergency medical services personnel.
10. The need for a weather monitoring person designated person(s) to monitor weather, and to implement emergency procedures in accordance with the event public safety plan.

403.12.3.1 Number of crowd managers. Not fewer than two trained crowd managers, and not fewer than one trained crowd manager for each 250 persons or portion thereof, shall be provided for the gathering.

Exceptions:

1. ~~Outdoor events with fewer than 1,000 persons in attendance shall not require crowd managers.~~
- ~~2.1.~~ Assembly occupancies used exclusively for religious worship with an occupant load not exceeding 1,000 shall not require crowd managers.
- ~~3.2.~~ The number of crowd managers shall be reduced where, in the opinion of the *fire code official*, the fire protection provided by the facility and the nature of the event warrant a reduction.

403.12.3.3 Duties. The duties of crowd managers shall include, but not be limited to:

1. Conduct an inspection of the area of responsibility and identify and address any egress barriers.
2. Conduct an inspection of the area of responsibility to identify and mitigate any fire hazards.
3. Verify compliance with all permit conditions, including those governing pyrotechnics and other special effects.
4. Establish and maintain open communication with the event designated person(s) at all times during the event
- ~~5.~~ Direct and assist the event attendees in evacuation during an emergency.
- ~~5-6.~~ Assist emergency response personnel where requested.
- ~~6-7.~~ Other duties required by the *fire code official*.
- ~~7-8.~~ Other duties as specified in the fire safety plan.

Reason:

The first change, in 403.12.2 item 10, clarifies that a designated weather monitoring person is an important consideration for an approved level of public safety. This correlates with Section 3106.4.2, which already requires a weather monitoring person upon request of the FCO. If the FCO determines such a person is needed, then that person

has one of the most important tasks potentially occurring at an outdoor assembly event: evacuation in accordance with the public safety plan.

403.12.3.1 currently allows an exception to the trained crowd management requirement for outdoor assembly events with occupancy less than 1,000. This is inconsistent with the basic requirement established by 403.12.3.1, and the exception places an undue burden on the designated (weather monitoring) person, if so required by the FCO under 403.12.2. The second proposed change, in 403.12.3.1, removes the exception for outdoor assembly events, such that anytime a designated (weather monitoring) person is required by the FCO, that designated person will also have support personnel should an evacuation become necessary. The minimum number of trained crowd managers required is already established at one per 250 persons by 403.12.3.1.

Accordingly, the third proposed change, in section 403.12.3.3, adds a communication requirement to the list of trained crowd manager responsibilities.

Recent event tragedies in the US and around the world (Wood Dale Festival tent collapse; New Hampshire Circus Tent collapse, Brazil EDM festival and others) have proven the importance of weather monitoring, and of trained personnel to properly direct the public. Weather monitoring is a critically important prevention tool. Trained Crowd Managers are critically important to incident mitigation.

Cost Impact

The code change proposal will not increase or decrease the cost of construction .

The first proposed change has no direct impact on cost of construction. Since the proposed change modifies an existing risk assessment item in the FCO's public safety plan checklist of requirements, any cost impact is directly related to the FCO's risk assessment and reduction requirements, and not to the requirement itself.

The second proposed change has no impact on cost of construction. Removing the exception for outdoor events maintains consistency with the existing requirement, which is irrespective of indoor or outdoor events. The net staff increase for events <1,000 persons is 1 or 2 additional staff. The cost of additional staff is inconsequential compared to the overall monetary cost of event production.

The third proposed change has no impact on cost of construction, as it clarifies an implied reasonable requirement for staff responsibilities when such staff is already required per the event public safety plan.

Internal ID: 1158

F37-18

IFC: 404.1

Proponent: Joe McElvaney, self, representing Self (joemcelvaney@gmail.com)

2018 International Fire Code

Revise as follows:

404.1 General. ~~Where required by Section 403, fire~~ Fire safety, evacuation and lockdown plans shall comply with Sections 404.2 through 404.4.1.

Reason:

As currently written section 404 would only apply to those occupancies in section 403 to have fire safety, evacuation and/or lockdown plans.

However section 403 does not required any occupancies to have a lockdown plan.

Plus if an owner wishes to have a fire safety, evacuation plan and/or lockdownplan, it would make sense to use the same requirement/format for those occupancies as outline in section 404

Cost Impact

The code change proposal will increase the cost of construction .

This code change will increase the cost of construction, by requiring all occupancies that are required or not required to have a fire safety, evacuation and/or lockdown plan to use the same outline/format as called out in IFC section 404.

Internal ID: 433

F38-18

IFC: 404.2.2

Proponent: Robert Davidson, Davidson Code Concepts, LLC, representing Self (rjd@davidsoncodeconcepts.com); William Kramer, School District of Philadelphia, representing School District of Philadelphia (wkramer@philasd.org)

2018 International Fire Code

Revise as follows:

404.2.2 Fire safety plans. Fire safety plans shall include the following:

1. The procedure for reporting a fire or other emergency.
2. The life safety strategy including the following:
 - 2.1. Procedures for notifying occupants, including areas with a private mode alarm system.
 - 2.2. Procedures for occupants under a defend-in-place response.
 - 2.3. Procedures for evacuating occupants, including those who need evacuation assistance.
3. Site plans indicating the following:
 - 3.1. The occupancy assembly point.
 - 3.2. The locations of fire hydrants.
 - 3.3. The normal routes of fire department vehicle access.
4. Floor plans identifying the locations of the following:
 - 4.1. Exits.
 - 4.2. Primary evacuation routes.
 - 4.3. Secondary evacuation routes.
 - 4.4. Accessible egress routes.
 - 4.4.1. Areas of refuge.
 - 4.4.2. Exterior areas for assisted rescue.
 - 4.5. Refuge areas associated with *smoke barriers* and *horizontal exits*.
 - 4.6. Manual fire alarm boxes.
 - 4.7. Portable fire extinguishers.
 - 4.8. Occupant-use hose stations.
 - 4.9. Fire alarm annunciators and controls.
5. A list of major fire hazards associated with the normal use and occupancy of the premises, including maintenance and housekeeping procedures.
6. Identification and assignment of personnel responsible for maintenance of systems and equipment installed to prevent or control fires.
7. Identification and assignment of personnel responsible for maintenance, housekeeping and controlling fuel hazard sources.
8. Exterior doors shall be identified on plans with the exposure side alphabetical prefix that coincides with the National Incident Management System exterior Incident command system (ICS) division designation coupled with sequential numeric door number assignments.

Reason:

The IFC does not include recommendations for exterior door numbering that is in compliance with incident management procedures. Due to the lack this being addressed in the IFC for emergency planning purposes a number of agencies have developed recommendations that are not in compliance with NIMS. The most common recommendation starts with the main entrance door being labeled as 1, and then sequentially clockwise around the building.

In an emergency situation, especially one that requires mutual aid, it is imperative that we know where our assignments are. In addition, should we run into an emergency inside a building we need to be able to quickly identify where the person in need is located. By failing to utilize the geographic locations of ICS we have failed to ensure a

quick, effective and safe response.

A simple fix is to require that a prefix be utilized that coincides with the exterior ICS division designations. Therefore, the main entrance would be Door A1. From a response perspective if I am responding to an active shooter situation, or other emergency, in a school and I am ordered to report to Door 4, I have no idea where that is. However, if I am ordered to report to Door C4 I know it is in the rear of the building. Likewise, if I am an officer in need of assistance from inside a building and can see an exit door that is labeled from the inside, if it is Door 5, no one except those familiar with the building will know where that is. If however, that same door is labeled D5, everyone knows it is on the right side of the building.

The adoption of a nationwide system of managing incidents and events starts with the basic knowledge that everyone is speaking the same language. That starts with the geographic divisions of an incident. Therefore, the simple addition of adding a prefix and number for exterior doors of a building and requiring them to be labeled inside and outside, is paramount for officer and occupant safety. I am requesting that the ICC consider adding these requirements to the IFC.

This proposal adds a requirement that in preparing fire safety plans the exterior doors be designated and indicated utilizing alphanumeric designations coinciding with the ICS division side and the sequential door number.

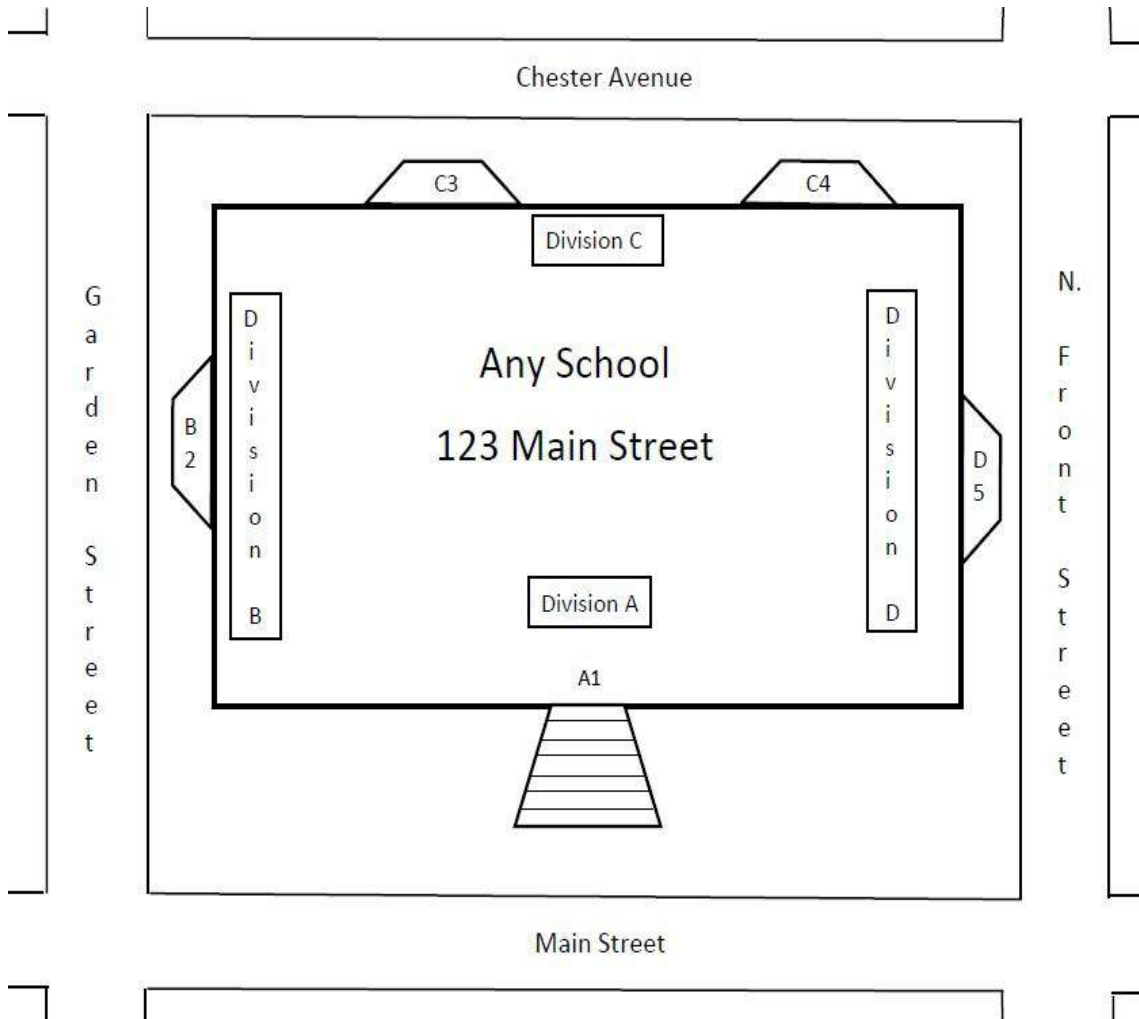

Cost Impact

The code change proposal will not increase or decrease the cost of construction .

This proposal has no impact on the cost of construction. It has a minimal cost impact on the preparation of fire safety plans.

Internal ID: 1692

F39-18

IFC: 404.2.3, 404.3, 404.4, 404.4.1, 405, 405.1

Proponent: John Williams, Chair, representing Healthcare Committee (AHC@iccsafe.org); Michael O'Brian, Chair, representing FCAC (fcac@iccsafe.org)

2018 International Fire Code

Delete without substitution:

~~**404.2.3 Lockdown plans.** Lockdown plans shall only be permitted where such plans are approved by the *fire code official* and are in compliance with Sections 404.2.3.1 and 404.2.3.2.~~

Revise as follows:

404.3 Maintenance. Fire safety and evacuation plans and lockdown plans shall be reviewed or updated annually or as necessitated by changes in staff assignments, occupancy or the physical arrangement of the building.

404.4 Availability. Fire safety and evacuation plans and lockdown plans shall be available in the workplace for reference and review by employees, and copies shall be furnished to the fire code official for review on request.

404.4.1 Distribution. The fire safety and evacuation plans and lockdown plans shall be distributed to the tenants and building service employees by the owner or owner's agent. Tenants shall distribute to their employees applicable parts of the fire safety plan and lockdown plans affecting the employees' actions in the event of a fire or other emergency.

SECTION 405 EMERGENCY EVACUATION DRILLS

405.1 General. Emergency fire and evacuation drills complying with Sections 405.2 through 405.9 shall be conducted not less than annually where fire safety and evacuation plans are required by Section 403 or where required by the *fire code official*. Lockdown plan drills shall be conducted in accordance with the approved plan. Such drills shall not be substituted for fire and evacuation drills required by Section 405.2. Drills shall be designed in cooperation with the local authorities.

Reason:

This is a series of proposal to coordinate the fire safety, evacuation and lock down plans between Groups I-1, I-2, I-3, R-4 and ambulatory care facilities. The FCAC and Healthcare committees worked together to address all situations where a staged evacuation or defend-in-place is utilized. See the proposal to IFC Section 403.3 for information on what these changes will look like if all pass.

A hospital can have lock down plans related to a possible infant or child abduction. There are similar situation where there are concerns patient's wandering or leaving the facility - such as dementia, addition recovery or psychiatric wards.

The current list of information seems appropriate for lock down plans in hospitals. However, it was noted that the requirements were not carried through into the provisions for maintenance, availability, distribution and drills.

Section 405 is labeled emergency evacuation drills, but does not mention the drills required for lockdowns - which, while they may start with locking-down, still include eventual directed evacuation. The last section of the lock-down plans, which mentions drills, is moved to the general section under emergency drills to clarify this.

This proposal is submitted by the ICC Fire Code Action Committee (FCAC) and the ICC Committee on Healthcare (CHC).

The FCAC was established by the ICC Board of Directors to pursue opportunities to improve and enhance assigned International Codes with regard to fire safety and hazardous materials in new and existing buildings and facilities and the protection of life and property in wildland urban interface areas. In 2017 the Fire-CAC has held 3 open meetings. In addition, there were numerous conference calls, Regional Work Group and Task Group meetings for the current code development cycle, which included members of the committees as well as any interested parties, to discuss and debate the proposed changes. Related documentation and reports are posted on the FCAC website at: <https://www.iccsafe.org/codes-tech-support/cs/fire-code-action-committee-fcac/>

The CHC was established by the ICC Board to evaluate and assess contemporary code issues relating to healthcare facilities. This is a joint effort between ICC and the American Society for Healthcare Engineering (ASHE), a subsidiary of the American Hospital Association, to eliminate duplication and conflicts in healthcare regulation. In 2017 the CHC held 2 open meetings and numerous conference calls, which included members of the committees as well as any interested

parties, to discuss and debate the proposed changes. Information on the CHC, including: meeting agendas; minutes; reports; resource documents; presentations; and all other materials developed in conjunction with the CHC effort can be downloaded from the CHC website at: <https://www.iccsafe.org/codes-tech-support/cs/icc-committee-on-healthcare/>.

Cost Impact

The code change proposal will not increase or decrease the cost of construction .

These are operational requirements for emergency responders, resident and staff safety

Internal ID: 689

F40-18

IFC: 503.1.1, 507.5.1, 805.1.1.2, 805.1.2.2, 805.2.1.2, 805.2.2.2, 805.4.1.2, 805.4.2.2, 806.1.1, 807.2, 807.4, 807.5.2.1, 807.5.3.1, 807.5.3.4, 807.5.3.3, 807.5.3.2, 807.5.5.1, 903.1.1, 903.2, 903.2.11.1.3, 903.2.11.1.2, 903.2.11.2, 903.3.1, 903.5, 904.12.5.3, 905.4.1, 907.2.3, 907.2.9.1, 910.2, 910.4.1, 914.4.1, [BE]1006.2.2.3, [BE]1010.3.2, [BE]1028.1, [BE]1029.6.2.3, 1103.4.9.3, 1103.5.3, 1103.5.4, 1103.7.6, [BE]1104.16.2, 1104.17, 1104.17.1, 2309.3.1.5.2, 2404.2, 2404.4, 2404.5.2, 2405.2, 2405.4.1, 2405.4.1.1, 2405.9.4, 2407.4, 2703.10, 2703.10.2, 2703.10.3, 2703.10.4, 2703.10.4.1, 2703.10.4.4.1, 2703.10.4.2, 2807.3, 2808.7, TABLE 3206.2, 3207.2, 3208.2, 3209.2, 3803.1.7, 3804.1.1.9, TABLE 5003.1.1(1), TABLE 5003.1.1(2), TABLE 5003.11.1, 5004.5, TABLE 5104.3.1, TABLE 5104.3.2, 5104.5.2, 5704.2.9.2.3, TABLE 5704.3.4.1, 5704.3.6.2, 5705.3.6.2.3, 5705.3.7.3, 5705.5, 6003.2.5, 6004.1.2, 6004.1.3, 6004.2.2.6, 6004.3.3, 6504.1.1, 6504.2, 6704.1.3, B105.3, TABLE C102.1, D104.2, D106.1, D106.2, D107.1, K102.5.3, N105.4, N106.1;

IBC: [F] TABLE 307.1(2), 402.6.2, 413.2, [F]415.11.11, [F] TABLE 414.2.5(2), [F] 415.11.2, [F] 415.11.11.1, [F] 415.8.5, [F] 428.3.9, 505.2.1, 510.2, 713.11, 713.13.6, [F] 806.2, [F] 903.2.11.1.2, [F]903.2.11.1.3, [F] 903.2, [F] 905.4.1, [F] 907.2.3, [F] 907.2.9.1, [F] 910.2, 910.4.1, 1006.2.2.3, 1028.1, 1029.6.2.3, 2603.3, C102.3;

IEBC: 504.5, 802.2.1, 803.1.1, 805.3.1.2.1, 805.5.1, 1011.7.3, 1204.4

Proponent: Jeffrey Hugo, representing National Fire Sprinkler Association (hugo@nfsa.org)

2018 International Fire Code

503.1.1 Buildings and facilities. *Approved* fire apparatus access roads shall be provided for every facility, building or portion of a building hereafter constructed or moved into or within the jurisdiction. The fire apparatus access road shall comply with the requirements of this section and shall extend to within 150 feet (45 720 mm) of all portions of the facility and all portions of the *exterior walls* of the first story of the building as measured by an *approved* route around the exterior of the building or facility.

Exceptions:

1. The *fire code official* is authorized to increase the dimension of 150 feet (45 720 mm) where any of the following conditions occur:
 - 1.1. The building is equipped throughout with an ~~approved~~ *automatic sprinkler system* installed in accordance with Section 903.3.1.1, 903.3.1.2 or ~~903.3.1.3~~ 903.3.1.3.
 - 1.2. Fire apparatus access roads cannot be installed because of location on property, topography, waterways, nonnegotiable grades or other similar conditions, and an *approved* alternative means of fire protection is provided.
 - 1.3. There are not more than two Group R-3 or Group U occupancies.
2. Where approved by the *fire code official*, fire apparatus access roads shall be permitted to be exempted or modified for solar photovoltaic power generation facilities.

507.5.1 Where required. Where a portion of the facility or building hereafter constructed or moved into or within the jurisdiction is more than 400 feet (122 m) from a hydrant on a fire apparatus access road, as measured by an *approved* route around the exterior of the facility or building, on-site fire hydrants and mains shall be provided where required by the *fire code official*.

Exceptions:

1. For Group R-3 and Group U occupancies, the distance requirement shall be 600 feet (183 m).
2. For buildings equipped throughout with an ~~approved~~ *automatic sprinkler system* installed in accordance with Section 903.3.1.1 or 903.3.1.2, the distance requirement shall be 600 feet (183 m).

805.1.1.2 Heat release rate. Newly introduced upholstered furniture shall have limited rates of heat release when tested in accordance with ASTM E1537 or California Technical Bulletin 133, as follows:

1. The peak rate of heat release for the single upholstered furniture item shall not exceed 80 kW.

Exception: Upholstered furniture in rooms or spaces protected by an ~~approved~~ *automatic sprinkler system* installed in accordance with Section ~~903.3.1.1~~ 903.3.1.1.
2. The total heat released by the single upholstered furniture item during the first 10 minutes of the test shall not exceed 25 megajoules (MJ).

Exception: Upholstered furniture in rooms or spaces protected by an ~~approved~~ *automatic*

sprinkler system installed in accordance with Section ~~903.3.1.1~~903.3.1.1.

805.1.2.2 Heat release rate. Newly introduced mattresses shall have limited rates of heat release when tested in accordance with ASTM E1590 or California Technical Bulletin 129, as follows:

1. The peak rate of heat release for the single mattress shall not exceed 100 kW.
Exception: Mattresses in rooms or spaces protected by an ~~approved-automatic sprinkler~~ system installed in accordance with Section ~~903.3.1.1~~903.3.1.1.
2. The total heat released by the single mattress during the first 10 minutes of the test shall not exceed 25 MJ.
Exception: Mattresses in rooms or spaces protected by an ~~approved-automatic sprinkler~~ system installed in accordance with Section ~~903.3.1.1~~903.3.1.1.

805.2.1.2 Heat release rate. Newly introduced upholstered furniture shall have limited rates of heat release when tested in accordance with ASTM E1537 or California Technical Bulletin 133, as follows:

1. The peak rate of heat release for the single upholstered furniture item shall not exceed 80 kW.
Exception: Upholstered furniture in rooms or spaces protected by an ~~approved-automatic sprinkler~~ system installed in accordance with Section ~~903.3.1.1~~903.3.1.1.
2. The total heat released by the single upholstered furniture item during the first 10 minutes of the test shall not exceed 25 MJ.
Exception: Upholstered furniture in rooms or spaces protected by an ~~approved-automatic sprinkler~~ system installed in accordance with Section ~~903.3.1.1~~903.3.1.1.

805.2.2.2 Heat release rate. Newly introduced mattresses shall have limited rates of heat release when tested in accordance with ASTM E1590 or California Technical Bulletin 129, as follows:

1. The peak rate of heat release for the single mattress shall not exceed 100 kW.
Exception: Mattresses in rooms or spaces protected by an ~~approved-automatic sprinkler~~ system installed in accordance with Section ~~903.3.1.1~~903.3.1.1.
2. The total heat released by the single mattress during the first 10 minutes of the test shall not exceed 25 MJ.
Exception: Mattresses in rooms or spaces protected by an ~~approved-automatic sprinkler~~ system installed in accordance with Section ~~903.3.1.1~~903.3.1.1.

805.4.1.2 Heat release rate. Newly introduced upholstered furniture shall have limited rates of heat release when tested in accordance with ASTM E1537 or California Technical Bulletin 133, as follows:

1. The peak rate of heat release for the single upholstered furniture item shall not exceed 80 kW.
Exception: Upholstered furniture in rooms or spaces protected by an ~~approved-automatic sprinkler~~ system installed in accordance with Section ~~903.3.1.1~~903.3.1.1.
2. The total heat released by the single upholstered furniture item during the first 10 minutes of the test shall not exceed 25 MJ.
Exception: Upholstered furniture in rooms or spaces protected by an ~~approved-automatic sprinkler~~ system installed in accordance with Section ~~903.3.1.1~~903.3.1.1.

805.4.2.2 Heat release rate. Newly introduced mattresses shall have limited rates of heat release when tested in accordance with ASTM E1590 or California Technical Bulletin 129, as follows:

1. The peak rate of heat release for the single mattress shall not exceed 100 kW.
Exception: Mattresses in rooms or spaces protected by an ~~approved-automatic sprinkler~~ system installed in accordance with Section ~~903.3.1.1~~903.3.1.1.
2. The total heat released by the single mattress during the first 10 minutes of the test shall not exceed 25 MJ.
Exception: Mattresses in rooms or spaces protected by an ~~approved-automatic sprinkler~~ system installed in accordance with Section ~~903.3.1.1~~903.3.1.1.

806.1.1 Restricted occupancies. Natural cut trees shall be prohibited within ambulatory care facilities and Group A, E, I-1, I-2, I-3, I-4, M, R-1, R-2 and R-4 occupancies.

Exceptions:

1. Trees located in areas protected by an ~~approved~~ *automatic sprinkler* system installed in accordance with Section 903.3.1.1 or 903.3.1.2 shall not be prohibited in Groups A, E, M, R-1 and R-2.
2. Trees shall be allowed within *dwelling units* in Group R-2 occupancies.

807.2 Combustible decorative materials. In Groups A, B, E, I, M and R-1 and in dormitories in Group R-2, curtains, draperies, fabric hangings and other similar combustible decorative materials suspended from walls or ceilings shall comply with Section 807.3 and shall not exceed 10 percent of the specific wall or ceiling area to which such materials are attached.

Fixed or movable walls and partitions, paneling, wall pads and crash pads applied structurally or for decoration, acoustical correction, surface insulation or other purposes shall be considered to be *interior finish*, shall comply with Section 803 and shall not be considered *decorative materials* or furnishings.

Exceptions:

1. In auditoriums in Group A, the permissible amount of curtains, draperies, fabric hangings and similar combustible decorative material suspended from walls or ceilings shall not exceed 75 percent of the aggregate wall area where the building is equipped throughout with an ~~approved~~ *automatic sprinkler* system in accordance with Section 903.3.1.1, and where the material is installed in accordance with Section 803.15 of the International Building Code Code.
2. In Group R-2 dormitories, within sleeping units and dwelling units, the permissible amount of curtains, draperies, fabric hangings and similar decorative materials suspended from walls or ceilings shall not exceed 50 percent of the aggregate wall areas where the building is equipped throughout with an ~~approved~~ *automatic sprinkler system* installed in accordance with Section ~~903.3.1~~ 903.3.1.
3. In Group B and M occupancies, the amount of combustible fabric partitions suspended from the ceiling and not supported by the floor shall comply with Section 807.3 and shall not be limited.
4. The 10-percent limit shall not apply to curtains, draperies, fabric hangings and similar combustible decorative materials used as window coverings.

807.4 Artificial decorative vegetation. Artificial decorative vegetation shall comply with this section and the requirements of Sections 806.2 and ~~806.3~~ 806.3. Natural decorative vegetation shall comply with Section ~~806~~ 806.

Exception: Testing of artificial vegetation is not required in Group I-1; Group I-2, Condition 1; Group R-2; Group R-3; or Group R-4 occupancies equipped throughout with an ~~approved~~ *automatic sprinkler* system installed in accordance with Section 903.3.1, where such artificial vegetation complies with the following:

1. Wreaths and other decorative items on doors shall not obstruct the door operation and shall not exceed 50 percent of the surface area of the door.
2. Decorative artificial vegetation shall be limited to not more than 30 percent of the wall area to which it is attached.
3. Decorative artificial vegetation not on doors or walls shall not exceed 3 feet (914 mm) in any dimension.

807.5.2.1 Storage in corridors and lobbies. Clothing and personal effects shall not be stored in *corridors* and lobbies.

Exceptions:

1. *Corridors* protected by an ~~approved~~ *automatic sprinkler* system installed in accordance with Section ~~903.3.1.1~~ 903.3.1.1.
2. *Corridors* protected by an *approved* fire alarm system installed in accordance with Section ~~907~~ 907.
3. Storage in metal lockers, provided the minimum required egress width is maintained.

807.5.3.1 Group I-1 and I-2 Condition 1 within units. In Group I-1 and Group I-2 Condition 1 occupancies, equipped throughout with an ~~approved~~ *automatic sprinkler* system installed in accordance with Section 903.3.1.1, within

sleeping units and dwelling units, combustible decorative materials placed on walls shall be limited to not more than 50 percent of the wall area to which they are attached.

807.5.3.4 Other areas in Groups I-1 and I-2. In Group I-1 and I-2 occupancies, in areas not equipped throughout with an ~~approved~~ automatic sprinkler system, combustible decorative materials shall be of such limited quantities that a hazard of fire development or spread is not present.

807.5.3.3 In Group I-2, Condition 2. In Group I-2, Condition 2 occupancies, equipped throughout with an ~~approved~~ automatic sprinkler system installed in accordance with Section 903.3.1.1, combustible decorative materials placed on walls shall be limited to not more than 30 percent of the wall area to which they are attached.

807.5.3.2 In Group I-1 and I-2, Condition 1 for areas other than within units. In Group I-1 and Group I-2, Condition 1 occupancies, equipped throughout with an ~~approved~~ automatic sprinkler system installed in accordance with Section 903.3.1.1, combustible decorative materials placed on walls in areas other than within dwelling and sleeping units shall be limited to not more than 30 percent of the wall area to which they are attached.

807.5.5.1 Storage in corridors and lobbies. Clothing and personal effects shall not be stored in corridors and lobbies.

Exceptions:

1. Corridors protected by an ~~approved~~ automatic sprinkler system installed in accordance with Section ~~903.3.1.1~~ 903.3.1.1.
2. Corridors protected by an approved fire alarm system installed in accordance with Section ~~907.907~~.
3. Storage in metal lockers, provided the minimum required egress width is maintained.

903.1.1 Alternative protection. Alternative automatic fire-extinguishing systems complying with Section 904 shall be permitted instead of automatic sprinkler system protection where recognized by the applicable standard and approved by the fire code official.

903.2 Where required. ~~Approved~~ Automatic automatic sprinkler systems in new buildings and structures shall be provided in the locations described in Sections 903.2.1 through ~~903.2.12~~ 903.2.12.

Exception: Spaces or areas in telecommunications buildings used exclusively for telecommunications equipment, associated electrical power distribution equipment, batteries and standby engines, provided that those spaces or areas are equipped throughout with an automatic smoke detection system in accordance with Section 907.2 and are separated from the remainder of the building by not less than 1-hour fire barriers constructed in accordance with Section 707 of the International Building Code or not less than 2-hour horizontal assemblies constructed in accordance with Section 711 of the International Building Code, or both.

903.2.11.1.3 Basements. Where any portion of a basement is located more than 75 feet (22 860 mm) from openings required by Section 903.2.11.1, or where walls, partitions or other obstructions are installed that restrict the application of water from hose streams, the basement shall be equipped throughout with an ~~approved~~ automatic sprinkler system.

903.2.11.1.2 Openings on one side only. Where openings in a story are provided on only one side and the opposite wall of such story is more than 75 feet (22 860 mm) from such openings, the story shall be equipped throughout with an ~~approved~~ automatic sprinkler system, or openings shall be provided on not fewer than two sides of the story.

903.2.11.2 Rubbish and linen chutes. An automatic sprinkler system shall be installed at the top of rubbish and linen chutes and in their terminal rooms. Chutes shall have additional ~~sprinkler heads~~ sprinklers installed at alternate floors and at the lowest intake. Where a rubbish chute extends through a building more than one floor below the lowest intake, the extension shall have sprinklers installed that are recessed from the drop area of the chute and protected from freezing in accordance with Section ~~903.3.1.1~~ 903.3.1.1. Such sprinklers shall be installed at alternate floors, beginning with the second level below the last intake and ending with the floor above the discharge. Access to sprinklers in chutes shall be provided for servicing.

903.3.1 Standards. ~~Sprinkler~~ Automatic sprinkler systems shall be designed and installed in accordance with Section 903.3.1.1, unless otherwise permitted by Sections 903.3.1.2 and 903.3.1.3 and other chapters of this code, as applicable.

903.5 Testing and maintenance. ~~Sprinkler~~ Automatic sprinkler systems shall be tested and maintained in accordance with Section ~~901.901~~.

904.12.5.3 Fusible link and sprinkler head replacement. Fusible links and automatic ~~sprinkler heads~~ ~~sprinklers~~ shall be replaced annually, and other protection devices shall be serviced or replaced in accordance with the manufacturer's instructions.

Exception: Frangible bulbs are not required to be replaced annually.

905.4.1 Protection. Risers and laterals of Class I standpipe systems not located within an *interior exit stairway* shall be protected by a degree of *fire resistance* equal to that required for vertical enclosures in the building in which they are located.

Exception: In buildings equipped throughout with an ~~approved~~ ~~automatic~~ automatic sprinkler system, laterals that are not located within an *interior exit stairway* are not required to be enclosed within fire-resistance-rated construction.

907.2.3 Group E. A manual fire alarm system that initiates the occupant notification signal utilizing an emergency voice/alarm communication system meeting the requirements of Section 907.5.2.2 and installed in accordance with Section 907.6 shall be installed in Group E occupancies. Where *automatic sprinkler systems* or smoke detectors are installed, such systems or detectors shall be connected to the building fire alarm system.

Exceptions:

1. A manual fire alarm system is not required in Group E occupancies with an *occupant load* of 50 or less.
2. Emergency voice/alarm communication systems meeting the requirements of Section 907.5.2.2 and installed in accordance with Section 907.6 shall not be required in Group E occupancies with occupant loads of 100 or less, provided that activation of the manual fire alarm system initiates an *approved* occupant notification signal in accordance with Section 907.5.
3. Manual fire alarm boxes are not required in Group E occupancies where all of the following apply:
 - 3.1. Interior *corridors* are protected by smoke detectors.
 - 3.2. Auditoriums, cafeterias, gymnasiums and similar areas are protected by *heat detectors* or other *approved* detection devices.
 - 3.3. Shops and laboratories involving dusts or vapors are protected by *heat detectors* or other *approved* detection devices.
4. Manual fire alarm boxes shall not be required in Group E occupancies where all of the following apply:
 - 4.1. The building is equipped throughout with an *approved automatic sprinkler system* installed in accordance with Section 903.3.1.1.
 - 4.2. The emergency voice/alarm communication system will activate on sprinkler water flow.
 - 4.3. Manual activation is provided from a normally occupied location.

907.2.9.1 Manual fire alarm system. A manual fire alarm system that activates the occupant notification system in accordance with Section 907.5 shall be installed in Group R-2 occupancies where any of the following conditions apply:

1. Any *dwelling unit* or *sleeping unit* is located three or more stories above the lowest *level of exit discharge*.
2. Any *dwelling unit* or *sleeping unit* is located more than one story below the highest *level of exit discharge* of exits serving the *dwelling unit* or *sleeping unit*.
3. The building contains more than 16 *dwelling units* or *sleeping units*.

Exceptions:

1. A fire alarm system is not required in buildings not more than two stories in height where all *dwelling units* or *sleeping units* and contiguous attic and crawl spaces are separated from each other and public or common areas by not less than 1-hour *fire partitions* and each *dwelling unit* or *sleeping unit* has an *exit* directly to a *public way*, *egress court* or yard.
2. Manual fire alarm boxes are not required where the building is equipped throughout with an *automatic sprinkler system* installed in accordance with Section 903.3.1.1 or 903.3.1.2 and the occupant notification appliances will automatically activate throughout the notification zones upon a sprinkler water flow.
3. A fire alarm system is not required in buildings that do not have interior *corridors* serving *dwelling*

units and are protected by an *approved automatic sprinkler system* installed in accordance with Section 903.3.1.1 or 903.3.1.2, provided that *dwelling units* either have a *means of egress* door opening directly to an exterior *exit access* that leads directly to the *exits* or are served by open-ended *corridors* designed in accordance with Section 1027.6, Exception 3.

910.2 Where required. Smoke and heat vents or a mechanical smoke removal system shall be installed as required by Sections 910.2.1 and 910.2.2.

Exceptions:

1. Frozen food warehouses used solely for storage of Class I and II commodities where protected by an ~~approved~~ *automatic sprinkler system*.
2. Smoke and heat removal shall not be required in areas of buildings equipped with early suppression fast-response (ESFR) sprinklers.

910.4.1 Automatic sprinklers required. The building shall be equipped throughout with an ~~approved automatic sprinkler system~~ in accordance with Section ~~903.3.1.1~~ 903.3.1.1.

914.4.1 Automatic sprinkler system. An ~~approved automatic sprinkler system~~ shall be installed throughout the entire building.

Exceptions:

1. That area of a building adjacent to or above the atrium need not be sprinklered, provided that portion of the building is separated from the atrium portion by not less than a 2-hour *fire barrier* constructed in accordance with Section 707 of the International Building Code or *horizontal assemblies* constructed in accordance with Section 711 of the International Building Code, or both.
2. Where the ceiling of the atrium is more than 55 feet (16 764 mm) above the floor, sprinkler protection at the ceiling of the atrium is not required.

[BE] 1006.2.2.3 Refrigerated rooms or spaces. Rooms or spaces having a floor area larger than 1,000 square feet (93 m²), containing a refrigerant evaporator and maintained at a temperature below 68°F (20°C), shall have access to not less than two *exits* or *exit access doorways*.

Exit access travel distance shall be determined as specified in Section 1017.1, but all portions of a refrigerated room or space shall be within 150 feet (45 720 mm) of an *exit* or *exit access doorway* where such rooms are not protected by an ~~approved automatic sprinkler system~~. Egress is allowed through adjoining refrigerated rooms or spaces.

Exception: Where using refrigerants in quantities limited to the amounts based on the volume set forth in the International Mechanical Code.

[BE] 1010.3.2 Security access turnstiles. Security access turnstiles that inhibit travel in the direction of egress utilizing a physical barrier shall be permitted to be considered as a component of the means of egress, provided that all of the following criteria are met:

1. The building is protected throughout by an ~~approved, supervised automatic sprinkler system~~ in accordance with Section 903.3.1.1.
2. Each security access turnstile lane configuration has a minimum clear passage width of 22 inches (559 mm).
3. Any security access turnstile lane configuration providing a clear passage width of less than 32 inches (810 mm) shall be credited with a maximum egress capacity of 50 persons.
4. Any security access turnstile lane configuration providing a clear passage width of 32 inches (810 mm) or more shall be credited with a maximum egress capacity as calculated in accordance with Section 1005.
5. Each secured physical barrier shall automatically retract or swing to an unobstructed open position in the direction of egress, under each of the following conditions:
 - 5.1. Upon loss of power to the turnstile or any part of the access control system that secures the physical barrier.
 - 5.2. Upon actuation of a clearly identified manual release device with ready access that results

in direct interruption of power to each secured physical barrier, after which such barriers remain in the open position for not less than 30 seconds. The manual release device shall be positioned at one of the following locations:

- 5.2.1. On the egress side of each security access turnstile lane.
- 5.2.2. At an approved location where it can be actuated by an employee assigned to the area at all times that the building is occupied.
- 5.3. Upon actuation of the building fire alarm system, if provided, after which the physical barrier remains in the open position until the fire alarm system is manually reset.

Exception: Actuation of a manual fire alarm box.

- 5.4. Upon actuation of the building automatic sprinkler or fire detection system, after which the physical barrier remains in the open position until the fire alarm system is manually reset.

Revise as follows:

[BE] 1028.1 General. Exits shall discharge directly to the exterior of the building. The *exit discharge* shall be at grade or shall provide a direct path of egress travel to grade. The *exit discharge* shall not reenter a building. The combined use of Exceptions 1 and 2 shall not exceed 50 percent of the number and minimum width or required capacity of the required *exits*.

Exceptions:

1. Not more than 50 percent of the number and minimum width or required capacity of *interior exit stairways* and *ramps* is permitted to egress through areas on the *level of discharge* provided that all of the following conditions are met:
 - 1.1. Discharge of *interior exit stairways* and *ramps* shall be provided with a free and unobstructed path of travel to an exterior exit door and such *exit* is readily visible and identifiable from the point of termination of the enclosure.
 - 1.2. The entire area of the *level of exit discharge* is separated from areas below by construction conforming to the *fire-resistance rating* for the enclosure.
 - 1.3. The egress path from the *interior exit stairway* and *ramp* on the *level of exit discharge* is protected throughout by an ~~approved~~ *automatic sprinkler system*. Portions of the *level of exit discharge* with access to the egress path shall either be equipped throughout with an *automatic sprinkler system* installed in accordance with Section 903.3.1.1 or 903.3.1.2, or separated from the egress path in accordance with the requirements for the enclosure of *interior exit stairways* or *ramps*.
 - 1.4. Where a required *interior exit stairway* or *ramp* and an *exit access stairway* or *ramp* serve the same floor level and terminate at the same *level of exit discharge*, the termination of the *exit access stairway* or *ramp* and the exit discharge door of the *interior exit stairway* or *ramp* shall be separated by a distance of not less than 30 feet (9144 mm) or not less than one-fourth the length of the maximum overall diagonal dimension of the building, whichever is less. The distance shall be measured in a straight line between the exit discharge door from the *interior exit stairway* or *ramp* and the last tread of the *exit access stairway* or termination of slope of the *exit access ramp*.
2. Not more than 50 percent of the number and minimum width or required capacity of the interior *exit stairways* and *ramps* is permitted to egress through a vestibule provided that all of the following conditions are met:
 - 2.1. The entire area of the vestibule is separated from areas below by construction conforming to the *fire-resistance rating* of the *interior exit stairway* or *ramp* enclosure.
 - 2.2. The depth from the exterior of the building is not greater than 10 feet (3048 mm) and the length is not greater than 30 feet (9144 mm).
 - 2.3. The area is separated from the remainder of the *level of exit discharge* by a *fire partition* constructed in accordance with Section 708 of the International Building Code.

Exception: The maximum transmitted temperature rise is not required.
 - 2.4. The area is used only for *means of egress* and *exits* directly to the outside.
3. *Horizontal exits* complying with Section 1026 shall not be required to discharge directly to the

exterior of the building.

[BE] 1029.6.2.3 Automatic sprinklers. Enclosed areas with walls and ceilings in buildings or structures containing *smoke-protected assembly seating* shall be protected with an ~~approved~~ *automatic sprinkler system* in accordance with Section ~~903.3.1.1-903.3.1.1~~.

Exceptions:

1. The floor area used for contests, performances or entertainment provided that the roof construction is more than 50 feet (15 240 mm) above the floor level and the use is restricted to low fire hazard uses.
2. Press boxes and storage facilities less than 1,000 square feet (93 m²) in area.
3. Outdoor seating facilities where seating and the *means of egress* in the seating area are essentially open to the outside.

1103.4.9.3 Automatic sprinkler system. Chutes shall be equipped with an ~~approved~~ *automatic sprinkler system* in accordance with Section ~~903.2.11.2-903.2.11.2~~.

1103.5.3 Group I-2, Condition 2. In addition to the requirements of Section 1103.5.2, existing buildings of Group I-2, Condition 2 occupancy shall be equipped throughout with an ~~approved~~ *automatic sprinkler system* in accordance with Section ~~903.3.1.1-903.3.1.1~~. The *automatic sprinkler system* shall be installed as established by the adopting ordinance. [DATE BY WHICH SPRINKLER SYSTEM MUST BE INSTALLED].

1103.5.4 Pyroxylin plastics. An *automatic sprinkler system* shall be provided throughout existing buildings where cellulose nitrate film or pyroxylin plastics are manufactured, stored or handled in quantities exceeding 100 pounds (45 kg). Vaults located within buildings for the storage of raw pyroxylin shall be protected with an ~~approved~~ *automatic sprinkler system* capable of discharging 1.66 gallons per minute per square foot (68 L/min/m²) over the area of the vault.

1103.7.6 Group R-2. A manual fire alarm system that activates the occupant notification system in accordance with Section 907.5 shall be installed in existing Group R-2 occupancies more than three stories in height or with more than 16 *dwelling or sleeping units*.

Exceptions:

1. Where each living unit is separated from other contiguous living units by *fire barriers* having a *fire-resistance rating* of not less than ³/₄ hour, and where each living unit has either its own independent *exit* or its own independent stairway or ramp discharging at grade.
2. A separate fire alarm system is not required in buildings that are equipped throughout with an ~~approved~~ *supervised automatic sprinkler system* installed in accordance with Section 903.3.1.1 or 903.3.1.2 and having a local alarm to notify all occupants.
3. A fire alarm system is not required in buildings that do not have interior *corridors* serving *dwelling units* and are protected by an *approved automatic sprinkler system* installed in accordance with Section 903.3.1.1 or 903.3.1.2, provided that *dwelling units* either have a *means of egress* door opening directly to an exterior *exit* access that leads directly to the *exits* or are served by open-ended *corridors* designed in accordance with Section 1027.6, Exception 3.
4. A fire alarm system is not required in buildings that do not have interior *corridors* serving *dwelling units*, do not exceed three stories in height and comply with both of the following:
 - 4.1. Each *dwelling unit* is separated from other contiguous *dwelling units* by *fire barriers* having a *fire-resistance rating* of not less than ³/₄ hour.
 - 4.2. Each *dwelling unit* is provided with hard-wired, interconnected smoke alarms as required for new construction in Section ~~907.2.10-907.2.10~~.

[BE] 1104.16.2 Opening protectives. Doors and windows within 10 feet (3048 mm) of fire escape *stairways* shall be protected with ³/₄-hour opening protectives.

Exception: Opening protectives shall not be required in buildings equipped throughout with an ~~approved~~ *automatic sprinkler system*.

1104.17 Corridor construction. Corridors serving an occupant load greater than 30 and the openings therein shall provide an effective barrier to resist the movement of smoke. Transoms, louvers, doors and other openings shall be kept closed or be self-closing. In Group I-2, corridors in areas housing patient sleeping or care rooms shall comply with

Section ~~1105.5~~, 1105.5.

Exceptions:

1. *Corridors* in occupancies other than in Group H, that are equipped throughout with an ~~approved~~ *automatic sprinkler system*.
2. *Corridors* in occupancies in Group E where each room utilized for instruction or assembly has not less than one-half of the required *means of egress* doors opening directly to the exterior of the building at ground level.
3. *Corridors* that are in accordance with the International Building Code.

1104.17.1 Corridor openings. Openings in *corridor* walls shall comply with the requirements of the International Building Code.

Exceptions:

1. Where 20-minute fire door assemblies are required, solid wood doors not less than 1.75 inches (44 mm) thick or insulated steel doors are allowed.
2. Openings protected with fixed wire glass set in steel frames.
3. Openings covered with 0.5-inch (12.7 mm) gypsum wallboard or 0.75-inch (19.1 mm) plywood on the room side.
4. Opening protection is not required where the building is equipped throughout with an ~~approved~~ *automatic sprinkler system*.

2309.3.1.5.2 Fire-extinguishing-Automatic sprinkler systems. Fuel-dispensing areas under canopies shall be equipped throughout with an ~~approved~~ *automatic sprinkler system* in accordance with Section ~~903.3.1.1~~, 903.3.1.1. The design of the sprinkler system shall be not less than that required for Extra Hazard Group 2 occupancies. Operation of the sprinkler system shall activate the emergency functions of Sections 2309.3.1.5.3 and ~~2309.3.1.5.4~~, 2309.3.1.5.4.

2404.2 Location of spray-finishing operations. Spray-finishing operations conducted in buildings used for Group A, E, I or R occupancies shall be located in a spray room protected with an ~~approved~~ *automatic sprinkler system* installed in accordance with Section 903.3.1.1 and separated vertically and horizontally from the remainder of the building by *fire barrier* walls and horizontal assemblies with not less than a 1-hour *fire-resistance rating* in accordance with the International Building Code. In other occupancies, spray-finishing operations shall be conducted in a spray room, spray booth or limited spraying space *approved* for such use.

Exceptions:

1. Automobile undercoating spray operations and spray-on automotive lining operations conducted in areas with *approved* natural or mechanical ventilation shall be exempt from the provisions of Section 2404 when *approved* and where utilizing Class IIIA or IIIB *combustible liquids*.
2. In buildings other than Group A, E, I or R occupancies, *approved* limited spraying space in accordance with Section ~~2404.9~~, 2404.9.
3. Resin application areas used for manufacturing of reinforced plastics complying with Section 2409 shall not be required to be located in a spray room, spray booth or spraying space.

2404.4 Fire protection. Spray booths and spray rooms shall be protected by an ~~approved~~ *automatic fire-extinguishing* ~~a fire protection~~ system complying with Chapter ~~9-9~~, 9-9. Protection shall extend to exhaust plenums, exhaust ducts and both sides of dry filters where such filters are used.

2404.5.2 Protection of sprinklers. Automatic sprinklers installed in *flammable vapor areas* shall be protected from the accumulation of residue from spraying operations in an *approved* manner. Bags used as a protective covering shall be 0.003-inch-thick (0.076 mm) ~~polyethylene or cellophane or shall be~~ thin paper. Automatic sprinklers contaminated by overspray particles shall be replaced with new automatic sprinklers.

2405.2 Location of dip-tank operations. Dip-tank operations conducted in buildings used for Group A, I or R occupancies shall be located in a room designed for that purpose, equipped with an ~~approved~~ *automatic sprinkler system* and separated vertically and horizontally from other areas in accordance with the International Building Code.

2405.4.1 Fixed fire -extinguishing-protection equipment. An ~~approved~~ *automatic fire -extinguishing-protection* system or dip-tank cover in accordance with Section 2405.3.4 shall be provided for the following dip tanks:

1. Dip tanks less than 150 gallons (568 L) in capacity or 10 square feet (0.93 m²) in liquid surface area.
2. Dip tanks containing a liquid with a *flash point* below 110°F (43°C) used in such manner that the liquid temperature could equal or be greater than its *flash point* from artificial or natural causes, and having both a capacity of more than 10 gallons (37.9 L) and a liquid surface area of more than 4 square feet (0.37 m²).

2405.4.1.1 Fire ~~extinguishing~~ protection system. An ~~approved automatic fire extinguishing protection system~~ shall be provided for dip tanks with a 150-gallon (568 L) or more capacity or 10 square feet (0.93 m²) or larger in a liquid surface area. Fire-extinguishing system design shall be in accordance with NFPA ~~34-34~~.

2405.9.4 Fire protection. Hardening and tempering tanks greater than 500 gallons (1893 L) in capacity or 25 square feet (2.3 m²) in liquid surface area shall be protected by an ~~approved automatic fire extinguishing protection system~~ complying with Chapter ~~9-9~~.

2407.4 Fire protection. Areas used for electrostatic spray finishing with fixed equipment shall be protected with an ~~approved automatic fire extinguishing protection system~~ complying with Chapter 9 and Section ~~2407.4.1-2407.4.1~~.

2703.10 Automatic sprinkler system. An ~~approved automatic sprinkler system~~ shall be provided in accordance with Sections 2703.10.1 through 2703.10.5 and Chapter 9.

2703.10.2 Gas cabinets and exhausted enclosures. An ~~approved automatic sprinkler system~~ shall be provided in gas cabinets and exhausted enclosures containing HPM *compressed gases*.

Exception: Gas cabinets located in an HPM room other than those cabinets containing pyrophoric gases.

2703.10.3 Pass-throughs in existing exit access corridors. Pass-throughs in existing *exit access corridors* shall be protected by an ~~approved automatic sprinkler system~~.

2703.10.4 Exhaust ducts for HPM. An ~~approved automatic sprinkler system~~ shall be provided in exhaust ducts conveying gases, vapors, fumes, mists or dusts generated from HPM in accordance with this section and the International Mechanical Code.

2703.10.4.1 Metallic and noncombustible nonmetallic exhaust ducts. An ~~approved automatic sprinkler system~~ shall be provided in metallic and noncombustible nonmetallic exhaust ducts where all of the following conditions apply:

1. Where the largest cross-sectional diameter is equal to or greater than 10 inches (254 mm).
2. The ducts are within the building.
3. The ducts are conveying flammable gases, vapors or fumes.

2703.10.4.1.1 Sprinkler head locations. Automatic sprinklers shall be installed at 12-foot (3658 mm) intervals in horizontal ducts and at changes in direction. In vertical runs, automatic sprinklers shall be installed at the top and at alternate floor levels.

2703.10.4.2 Combustible nonmetallic exhaust ducts. An ~~approved automatic sprinkler system~~ shall be provided in combustible nonmetallic exhaust ducts where the largest cross-sectional diameter of the duct is equal to or greater than 10 inches (254 mm).

Exceptions:

1. Ducts *listed or approved* for applications without *automatic sprinkler system* protection.
2. Ducts not more than 12 feet (3658 mm) in length installed below ceiling level.

2807.3 Pile fire protection. Automatic sprinkler protection shall be provided in conveyor tunnels and combustible enclosures that pass under a pile. Combustible or enclosed conveyor systems shall be equipped with an ~~approved automatic sprinkler system~~.

2808.7 Pile fire protection. Automatic sprinkler protection shall be provided in conveyor tunnels and combustible enclosures that pass under a pile. Combustible conveyor systems and enclosed conveyor systems shall be equipped with an ~~approved automatic sprinkler system~~.

**TABLE 3206.2
GENERAL FIRE PROTECTION AND LIFE SAFETY REQUIREMENTS**

COMMODITY CLASS	SIZE OF HIGH-PILED STORAGE AREA ^a (square feet) (see Sections 3206.2 and 3206.3)	ALL STORAGE AREAS (See Sections 3206, 3207 and 3208) ^b				SOLID-PILED STORAGE, SHELF STORAGE AND PALLETIZED STORAGE (see Section 3207.3)		
		Automatic fire-extinguishing system (see Section 3206.4)	Fire detection system (see Section 3206.5)	Fire department access doors (see Section 3206.7)	Smoke and heat removal (see Section 3206.8)	Maximum pile dimension ^c (feet)	Maximum permissible storage height ^d (feet)	Maximum pile volume (cubic feet)
HV	0-500	Not Required ^e	Not Required	Not Required	Not Required	Not Required	Not Required	Not Required
	501-2,500	Not Required ^e	Yes ^g	Not Required	Not Required	120	40	100,000
	2,501-12,000 Open to the public	Yes	Not Required	Not Required	Not Required	120	40	400,000
	2,501-12,000 Not open to the public (Option 1)	Yes	Not Required	Not Required ^h	Not Required	120	40	400,000
	2,501-12,000 Not open to the public (Option 2)	Not Required ^e	Yes	Yes	Yes ^{h, i}	120	30 ^e	200,000
	12,001-500,000	Yes	Not Required	Yes	Yes ^{h, i}	120	40	400,000
	Greater than 500,000	Yes	Not Required	Yes	Yes ^{h, i}	120	40	400,000
High hazard	0-500	Not Required ^e	Not Required	Not Required ^c	Not Required	60	Not Required	Not Required
	501-2,500 Open to the public	Yes	Not Required	Not Required ^e	Not Required	60	30	75,000
	501-2,500 Not open to the public (Option 1)	Yes	Not Required	Not Required ^c	Not Required	60	30	75,000
	501-2,500 Not open to the public (Option 2)	Not Required ^e	Yes ^g	Yes	Yes ^{h, i}	60	20	50,000
	2,501-300,000	Yes	Not Required	Yes	Yes ^{h, i}	60	30	75,000
	Greater than 300,000 ^f	Yes	Not Required	Yes	Yes ^{h, i}	60	30	75,000

For SI: 1 foot = 304.8 mm, 1 cubic foot = 0.02832 m³, 1 square foot = 0.0929 m².

- a. Where automatic sprinklers are required for reasons other than those in Chapter 32, the portion of the sprinkler system protecting the high-piled storage area shall be designed and installed in accordance with Sections 3207 and 3208.
- b. For aisles, see Section 3206.10.
- c. Piles shall be separated by aisles complying with Section 3206.10.
- d. For storage in excess of the height indicated, special fire protection shall be provided in accordance with Note f where required by the fire code official. See Chapters 51 and 57 for special limitations for aerosols and flammable and combustible liquids, respectively.
- e. For storage exceeding 30 feet in height, Option 1 shall be used.
- f. Special fire protection provisions including, but not limited to, fire protection of exposed steel columns; increased sprinkler density; additional in-rack sprinklers, without associated reductions in ceiling sprinkler density; or additional fire department hose connections shall be provided where required by the fire code official.
- g. Not required where an automatic fire-extinguishing system is designed and installed to protect the high-piled storage area in accordance with Sections 3207 and 3208.
- h. Not required where storage areas are protected by either early suppression fast response (ESFR) sprinkler systems or control mode special application sprinklers with a response time index of 50 (m • s)^{1/2} or less that are listed to control a fire in the stored commodities with 12 or fewer sprinklers, installed in accordance with NFPA 13.
- i. Not required in frozen food warehouses used solely for storage of Class I and II commodities where protected by an ~~approved~~ automatic sprinkler system.

3207.2 Fire protection. Where automatic sprinklers are required by Table 3206.2, an ~~approved~~ automatic sprinkler system shall be installed throughout the building or to 1-hour fire barriers constructed in accordance with Section 707 of the International Building Code. Openings in such *fire barriers* shall be protected by opening protectives having a 1-hour *fire protection rating*. The design and installation of the *automatic sprinkler system* and other applicable fire protection shall be in accordance with the International Building Code and NFPA 13.

3208.2 Fire protection. Where automatic sprinklers are required by Table 3206.2, an ~~approved~~ automatic sprinkler system shall be installed throughout the building or to 1-hour *fire barriers* constructed in accordance with Section 707 of the International Building Code. Openings in such *fire barriers* shall be protected by opening protectives having a 1-hour *fire protection rating*. The design and installation of the *automatic sprinkler system* and other applicable fire protection shall be in accordance with Section 903.3.1.1 and the International Building Code.

3209.2 Automatic ~~sprinklers~~ sprinkler system. Where automatic sprinklers are required by Table 3206.2, the building shall be equipped throughout with an ~~approved~~ automatic sprinkler system in accordance with Section 903.3.1.1.

3803.1.7 Automatic ~~fire-extinguishing~~ sprinkler systems. New laboratories in new or existing buildings that increase maximum allowable quantities of hazardous materials based on the requirements in this chapter shall be equipped throughout with an ~~approved~~ automatic sprinkler system in accordance with Section 903.3.1.1.

3804.1.1.9 Automatic ~~fire-extinguishing~~ sprinkler systems. Buildings containing laboratory suites shall be equipped throughout with an ~~approved~~ automatic sprinkler system in accordance with Section 903.3.1.1.

TABLE 5003.1.1(1)
MAXIMUM ALLOWABLE QUANTITY PER CONTROL AREA OF HAZARDOUS MATERIALS POSING A PHYSICAL HAZARDa, j, m, n, p

MATERIAL	CLASS	GROUP WHEN THE MAXIMUM ALLOWABLE QUANTITY IS EXCEEDED	STORAGE ^b			USE-CLOSED SYSTEMS ^b			USE-OPEN SYSTEMS ^b	
			Solid pounds(cubic feet)	Liquid gallons (pounds)	Gas (cubic feet at NTP)	Solid pounds(cubic feet)	Liquid gallons (pounds)	Gas (cubic feet at NTP)	Solid pounds(cubic feet)	Liquid gallons (pounds)
Combustible dust	NA	H-2	See Note q	NA	NA	See Note q	NA	NA	See Note q	NA
Combustible fibers ^q	Loose	H-3	(100)	NA	NA	(100)	NA	NA	(20)	NA
	Baled ^r		(1,000)			(1,000)			(200)	
Combustible liquid ^{r, t}	I	H-2 or H-3	NA	120 ^{u, v}	NA	NA	120 ^u	NA	NA	30 ^u
	II	H-2 or H-3		330 ^{u, v}			330 ^u			80 ^u
	III	NA		13,200 ^{u, v}			13,200 ^u			3,300 ^u
Cryogenic Flammable	NA	H-2	NA	45 ^u	NA	NA	45 ^u	NA	NA	10 ^u
Cryogenic Inert	NA	NA	NA	NA	NL	NA	NA	NL	NA	NA
Cryogenic Oxidizing	NA	H-3	NA	45 ^u	NA	NA	45 ^u	NA	NA	10 ^u
Explosives	Division 1.1	H-1	1 ^{u, v}	(1) ^{u, v}	NA	0.25 ^u	(0.25) ^u	NA	0.25 ^u	(0.25) ^u
	Division 1.2	H-1	1 ^{u, v}	(1) ^{u, v}		0.25 ^u	(0.25) ^u		0.25 ^u	(0.25) ^u
	Division 1.3	H-1 or H-2	5 ^{u, v}	(5) ^{u, v}		1 ^u	(1) ^u		1 ^u	(1) ^u
	Division 1.4	H-3	50 ^{u, v}	(50) ^{u, v}		50 ^u	(50) ^u		NA	NA
	Division 1.4G	H-3	125 ^{u, v}	NA		NA	NA		NA	NA
	Division 1.5	H-1	1 ^{u, v}	(1) ^{u, v}		0.25 ^u	(0.25) ^u		0.25 ^u	(0.25) ^u
	Division 1.6	H-1	1 ^{u, v}	NA		NA	NA		NA	NA
Flammable Gas	Gaseous	H-2	NA	NA	1,000 ^{u, v}	NA	NA	1,000 ^{u, v}	NA	NA
	Liquefied			(150) ^{u, v}	NA		(150) ^{u, v}	NA		
Flammable liquid ^u	I	H-2 or H-3	NA	30 ^{u, v}	NA	NA	30 ^u	NA	NA	10 ^u
	II and III			120 ^{u, v}			120 ^u			30 ^u
Flammable liquid, combination (I, II, III)	NA	H-2 or H-3	NA	120 ^{u, v, w}	NA	NA	120 ^{u, v, w}	NA	NA	30 ^{u, v, w}
Flammable solid	NA	H-3	125 ^{u, v}	NA	NA	125 ^u	NA	NA	25 ^u	NA
Inert Gas	Gaseous	NA	NA	NA	NL	NA	NA	NL	NA	NA
	Liquefied	NA	NA	NA	NL	NA	NA	NL	NA	NA
Organic peroxide	UD	H-1	1 ^{u, v}	(1) ^{u, v}	NA	0.25 ^u	(0.25) ^u	NA	0.25 ^u	(0.25) ^u
	I	H-2	5 ^{u, v}	(5) ^{u, v}		1 ^u	(1) ^u		1 ^u	(1) ^u
	II	H-3	50 ^{u, v}	(50) ^{u, v}		50 ^u	(50) ^u		10 ^u	(10) ^u
	III	H-3	125 ^{u, v}	(125) ^{u, v}		125 ^u	(125) ^u		25 ^u	(25) ^u
	IV	NA	NL	NL		NL	NL		NL	NL
	V	NA	NL	NL		NL	NL		NL	NL
Oxidizer	4	H-1	1 ^u	(1) ^{u, v}	NA	0.25 ^u	(0.25) ^u	NA	0.25 ^u	(0.25) ^u
	3 ^u	H-2 or H-3	10 ^{u, v}	(10) ^{u, v}		2 ^u	(2) ^u		2 ^u	(2) ^u
	2	H-3	250 ^{u, v}	(250) ^{u, v}		250 ^u	(250) ^u		50 ^u	(50) ^u
	1	NA	4,000 ^{u, v}	(4,000) ^{u, v}		4,000 ^u	(4,000) ^u		1,000 ^u	(1,000) ^u
Oxidizing Gas	Gaseous	H-3	NA	NA	1,500 ^{u, v}	NA	NA	1,500 ^{u, v}	NA	NA
	Liquefied			(150) ^{u, v}	NA		(150) ^{u, v}	NA		
Pyrophoric	NA	H-2	4 ^{u, v}	(4) ^{u, v}	50 ^{u, v}	1 ^u	(1) ^u	10 ^{u, v}	0	0
Unstable (reactive)	4	H-1	1 ^{u, v}	(1) ^{u, v}	10 ^{u, v}	0.25 ^u	(0.25) ^u	2 ^{u, v}	0.25 ^u	(0.25) ^u
	3	H-1 or H-2	5 ^{u, v}	(5) ^{u, v}	50 ^{u, v}	1 ^u	(1) ^u	10 ^{u, v}	1 ^u	(1) ^u
	2	H-3	50 ^{u, v}	(50) ^{u, v}	750 ^{u, v}	50 ^u	(50) ^u	750 ^{u, v}	10 ^u	(10) ^u
	1	NA	NL	NL	NL	NL	NL	NL	NL	NL
Water reactive	3	H-2	5 ^{u, v}	(5) ^{u, v}	NA	5 ^u	(5) ^u	NA	1 ^u	(1) ^u
	2	H-3	50 ^{u, v}	(50) ^{u, v}		50 ^u	(50) ^u		10 ^u	(10) ^u
	1	NA	NL	NL		NL	NL		NL	NL

For SI: 1 cubic foot = 0.02832 m³, 1 pound = 0.454 kg, 1 gallon = 3.785 L.

NA = Not Applicable, NL = Not Limited, UD = Unclassified Detonable.

- a. For use of control areas, see Section 5003.8.3.
- b. The aggregate quantity in use and storage shall not exceed the quantity listed for storage.
- c. The quantities of alcoholic beverages in retail and wholesale sales occupancies shall not be limited providing the liquids are packaged in individual containers not exceeding 1.3 gallons. In retail and wholesale sales occupancies, the quantities of medicines, foodstuff or consumer products and cosmetics containing not more than 50 percent by volume of water-miscible liquids with the remainder of the solutions not being flammable shall not be limited, provided that such materials are packaged in individual containers not exceeding 1.3 gallons.
- d. Maximum allowable quantities shall be increased 100 percent in buildings equipped throughout with a ~~non-approved~~ automatic sprinkler system in accordance with Section 903.3.1.1. Where Note e applies, the increase for both notes shall be applied accumulatively.
- e. Maximum allowable quantities shall be increased 100 percent where stored in approved storage cabinets, day boxes, gas cabinets, gas rooms, exhausted enclosures or in listed safety cans in accordance with Section 5003.9.10. Where Note d applies, the increase for both notes shall be applied accumulatively.
- f. Quantities shall not be limited in a building equipped throughout with an ~~approved~~ automatic sprinkler system in accordance with Section 903.3.1.1.
- g. Allowed only in buildings equipped throughout with an ~~approved~~ automatic sprinkler system.
- h. Containing not more than the maximum allowable quantity per control area of Class IA, Class IB or Class IC flammable liquids.
- i. The maximum allowable quantity shall not apply to fuel oil storage complying with Section 603.3.2.
- j. Quantities in parenthesis indicate quantity units in parenthesis at the head of each column.
- k. A maximum quantity of 220 pounds of solid or 22 gallons of liquid Class 3 oxidizers is allowed where such materials are necessary for maintenance purposes, operation or sanitation of equipment where the storage containers and the manner of storage are approved.
- l. Net weight of pyrotechnic composition of the fireworks. Where the net weight of the pyrotechnic composition of the fireworks is not known, 25 percent of the gross weight of the fireworks including packaging shall be used.
- m. For gallons of liquids, divide the amount in pounds by 10 in accordance with Section 5003.1.2.
- n. For storage and display quantities in Group M and storage quantities in Group S occupancies complying with Section 5003.11, see Table 5003.11.1.
- o. Densely-packed baled cotton that complies with the packing requirements of ISO 8115 shall not be included in this material class.
- p. The following shall not be included in determining the maximum allowable quantities:
 1. Liquid or gaseous fuel in fuel tanks on vehicles.
 2. Liquid or gaseous fuel in fuel tanks on motorized equipment operated in accordance with this code.
 3. Gaseous fuels in piping systems and fixed appliances regulated by the International Fuel Gas Code.
 4. Liquid fuels in piping systems and fixed appliances regulated by the International Mechanical Code.
 5. Alcohol-based hand rubs classified as Class I or II liquids in dispensers that are installed in accordance with Sections 5705.5 and 5705.5.1. The location of the alcohol-based hand rub (ABHR) dispensers shall be provided in the construction documents.
- q. Where manufactured, generated or used in such a manner that the concentration and conditions create a fire or explosion hazard based on information prepared in accordance with Section 104.7.2.

**TABLE 5003.1.1(2)
 MAXIMUM ALLOWABLE QUANTITY PER CONTROL AREA OF HAZARDOUS MATERIAL POSING A HEALTH
 HAZARD^{a, c, f, h, i}**

MATERIAL	STORAGE ^b			USE-CLOSED SYSTEMS ^b			USE-OPEN SYSTEMS ^b	
	Solid pounds ^c	Liquid gallons(pounds) ^c	Gas cubic feet at NTP(pounds) ^c	Solid pounds ^c	Liquid gallons(pounds) ^c	Gas cubic feet at NTP(pounds) ^c	Solid pounds ^d	Liquid gallons(pounds) ^d
Corrosives	5,000	500	Gaseous 810 ^e Liquefied (150)	5,000	500	Gaseous 810 ^e Liquefied (150)	1,000	100
Highly Toxics	10	(10)	Gaseous 20 ^e Liquefied (4) ^e	10	(10)	Gaseous 20 ^e Liquefied (4) ^e	3	(3)
Toxics	500	(500)	Gaseous 810 ^e Liquefied (150) ^e	500	(500)	Gaseous 810 ^e Liquefied (150) ^e	125	(125)

For SI: 1 cubic foot = 0.02832 m³, 1 pound = 0.454 kg, 1 gallon = 3.785 L.

- a. For use of control areas, see Section 5003.8.3.
- b. The aggregate quantity in use and storage shall not exceed the quantity listed for storage.
- c. In retail and wholesale sales occupancies, the quantities of medicines, foodstuff or consumer products and cosmetics, containing not more than 50 percent by volume of water-miscible liquids and with the remainder of the solutions not being flammable, shall not be limited, provided that such materials are packaged in individual containers not exceeding 1.3 gallons.
- d. Maximum allowable quantities shall be increased 100 percent in buildings equipped throughout with an ~~approved~~ automatic sprinkler system in accordance with Section 903.3.1.1. Where Note e also applies, the increase for both notes shall be applied accumulatively.
- e. Maximum allowable quantities shall be increased 100 percent where stored in approved storage cabinets, gas cabinets or exhausted enclosures. Where Note d applies, the increase for both notes shall be applied accumulatively.
- f. For storage and display quantities in Group M and storage quantities in Group S occupancies complying with Section 5003.11, see Table 5003.11.1.
- g. Allowed only where stored in approved exhausted gas cabinets or exhausted enclosures.
- h. Quantities in parentheses indicate quantity units in parentheses at the head of each column.
- i. For gallons of liquids, divide the amount in pounds by 10 in accordance with Section 5003.1.2.

TABLE 5003.11.1
MAXIMUM ALLOWABLE QUANTITY PER INDOOR AND OUT DOOR CONTROL AREA IN GROUP M AND S
~~**OCCUPANCIES—NONFLAMMABLE OCCUPANCIES—NONFLAMMABLE SOLIDS, NONFLAMMABLE AND**~~
NONCOMBUSTIBLE LIQUIDS^{d, e, f}

CONDITION		MAXIMUM ALLOWABLE QUANTITY PER CONTROL AREA	
Material^a	Class	Solids (pounds)	Liquids (gallons)
A. HEALTH-HAZARD MATERIALS—NONFLAMMABLE AND NONCOMBUSTIBLE SOLIDS AND LIQUIDS			
1. Corrosives ^{b, c}	Not Applicable	9,750	975
2. Highly Toxics	Not Applicable	20 ^{b, c}	2 ^{b, c}
3. Toxics ^{b, c}	Not Applicable	1,000	100
B. PHYSICAL-HAZARD MATERIALS—NONFLAMMABLE AND NONCOMBUSTIBLE SOLIDS AND LIQUIDS			
1. Oxidizers ^{b, c}	4	Not Allowed	Not Allowed
	3	1,350 ^g	135
	2	2,250 ^h	225
	1	18,000 ^{i, j}	1,800 ^{i, j}
2. Unstable (Reactives) ^{b, c}	4	Not Allowed	Not Allowed
	3	550	55
	2	1,150	115
	1	Not Limited	Not Limited
3. Water Reactives	3 ^{b, c}	550	55
	2 ^{b, c}	1,150	115
	1	Not Limited	Not Limited

For SI: 1 pound = 0.454 kg, 1 gallon = 3.785 L, 1 cubic foot = 0.02832 m³.

- a. Hazard categories are as specified in Section 5001.2.2.
- b. Maximum allowable quantities shall be increased 100 percent in buildings equipped throughout with an ~~approved~~ automatic sprinkler system in accordance with Section 903.3.1.1. Where Note c applies, the increase for both notes shall be applied accumulatively.
- c. Maximum allowable quantities shall be increased 100 percent where stored in approved storage cabinets in accordance with Section 5003.8. Where Note b applies, the increase for both notes shall be applied accumulatively.
- d. See Table 5003.8.3.2 for design and number of control areas.
- e. Maximum allowable quantities for other hazardous material categories shall be in accordance with Section 5003.1.
- f. Maximum allowable quantities shall be increased 100 percent in outdoor control areas.
- g. Maximum allowable quantities shall be increased to 2,250 pounds where individual packages are in the original sealed containers from the manufacturer or packager and do not exceed 10 pounds each.
- h. Maximum allowable quantities shall be increased to 4,500 pounds where individual packages are in the original sealed containers from the manufacturer or packager and do not exceed 10 pounds each.
- i. Quantities are unlimited where protected by an automatic sprinkler system.
- j. Quantities are unlimited in an outdoor control area.

5004.5 Automatic sprinkler systems. Indoor storage areas and storage buildings shall be equipped throughout with an ~~approved~~ *automatic sprinkler system* in accordance with Section 903.3.1.1. The design of the sprinkler system shall be not less than that required for Ordinary Hazard Group 2 with a minimum design area of 3,000 square feet (279 m²). Where the materials or storage arrangement are required by other regulations to be provided with a higher level of sprinkler system protection, the higher level of sprinkler system protection shall be provided.

TABLE 5104.3.1**NONSEGREGATED STORAGE OF LEVEL 2 AND 3 AEROSOL PRODUCTS IN GENERAL PURPOSE WAREHOUSES^b**

AEROSOL LEVEL	MAXIMUM NET WEIGHT PER FLOOR (pounds)^b			
	Palletized or solid-pile storage		Rack storage	
	Unprotected	Protected^a	Unprotected	Protected^a
2	2,500	12,000	2,500	24,000
3	1,000	12,000	1,000	24,000
Combination 2 and 3	2,500	12,000	2,500	24,000

For SI: 1 foot = 304.8 mm, 1 pound = 0.454 kg, 1 square foot = 0.0929 m².

- a. ~~Approved automatic~~ Automatic sprinkler system protection and storage arrangements shall comply with NFPA 30B. Sprinkler system protection shall extend 20 feet beyond the storage area containing the aerosol products.
- b. Storage quantities indicated are the maximum permitted in any 50,000- square-foot area.

**TABLE 5104.3.2
SEGREGATED STORAGE OF LEVEL 2 AND 3 AEROSOL PRODUCTS IN GENERAL PURPOSE WAREHOUSES**

STORAGE SEPARATION	MAXIMUM SEGREGATED STORAGE AREA ^a		SPRINKLER REQUIREMENTS
	Percentage of building area (percent)	Area limitation (square feet)	
Separation area ^{e, f}	15	20,000	Notes b, c
Chain-link fence enclosure ^d	20	20,000	Notes b, c
1-hour fire-resistance-rated interior walls	20	30,000	Note b
2-hour fire-resistance-rated interior walls	25	40,000	Note b
3-hour fire-resistance-rated interior walls	30	50,000	Note b

For SI: 1 foot = 304.8 mm, 1 square foot = 0.0929 m².

- a. The maximum segregated storage area shall be limited to the smaller of the two areas resulting from the percentage of building area limitation and the area limitation.
- b. Automatic sprinkler system protection in aerosol product storage areas shall comply with NFPA 30B and be approved. Building areas not containing aerosol product storage shall be equipped throughout with an ~~approved~~ automatic sprinkler system in accordance with Section 903.3.1.1.
- c. Automatic sprinkler system protection in aerosol product storage areas shall comply with NFPA 30B and be approved. Sprinkler system protection shall extend a minimum 20 feet beyond the aerosol storage area.
- d. Chain-link fence enclosures shall comply with Section 5104.3.2.1.
- e. A separation area shall be defined as an area extending outward from the periphery of the segregated aerosol product storage area as follows.
 1. The limits of the aerosol product storage shall be clearly marked on the floor.
 2. The separation distance shall be not less than 25 feet and maintained clear of all materials with a commodity classification greater than Class III in accordance with Section 903.3.1.1.
- f. Separation areas shall only be permitted where approved.

5104.5.2 Storage rooms greater than 500 square feet. The storage of aerosol products in flammable liquid storage rooms greater than 500 square feet (46 m²) in area shall not exceed the following quantities:

1. A net weight of 2,500 pounds (1135 kg) of Level 2 aerosol products.
2. A net weight of 1,000 pounds (454 kg) of Level 3 aerosol products.
3. A combined net weight of 2,500 pounds (1135 kg) of Level 2 and 3 aerosol products.

The maximum aggregate storage quantity of Level 2 and 3 aerosol products permitted in separate inside storage rooms protected by an ~~approved~~ automatic sprinkler system in accordance with NFPA 30B shall be 5,000 pounds (2270 kg).

5704.2.9.2.3 Fire protection of supports. Supports or pilings for above-ground tanks storing Class I, II or IIIA liquids elevated more than 12 inches (305 mm) above grade shall have a *fire-resistance rating* of not less than 2 hours in accordance with the fire exposure criteria specified in ASTM E1529.

Exceptions:

1. Structural supports tested as part of a protected above-ground tank in accordance with UL 2085.
2. Stationary tanks located outside of buildings where protected by an *approved* water-spray system designed in accordance with Chapter 9 and NFPA 15.
3. Stationary tanks located inside of buildings equipped throughout with an ~~approved~~ automatic sprinkler system designed in accordance with Section 903.3.1.1.

**TABLE 5704.3.4.1
 MAXIMUM ALLOWABLE QUANTITY PER CONTROL AREA OF FLAMMABLE AND COMBUSTIBLE LIQUIDS IN
 WHOLESALE AND RETAIL SALES OCCUPANCIES^a**

TYPE OF LIQUID	MAXIMUM ALLOWABLE QUANTITY PER CONTROL AREA (gallons)		
	Sprinklered^b in accordance with footnote densities and arrangements	Sprinklered in accordance with Tables 5704.3.6.3(4) through 5704.3.6.3(8) and Table 5704.3.7.5.1	Nonsprinklered
Class IA	60	60	30
Class IB, IC, II and IIIA	7,500 ^c	15,000 ^c	1,600
Class IIIB	Unlimited	Unlimited	13,200

For SI: 1 foot = 304.8 mm, 1 square foot = 0.0929 m², 1 gallon = 3.785 L, 1 gallon per minute per square foot = 40.75 L/min/m².

- a. Control areas shall be separated from each other by not less than a 1-hour fire barrier.
- b. To be considered as sprinklered, a building shall be equipped throughout with an ~~approved~~ automatic sprinkler system with a design providing minimum densities as follows:
 1. For uncartoned commodities on shelves 6 feet or less in height where the ceiling height does not exceed 18 feet, quantities are those allowed with a minimum sprinkler design density of Ordinary Hazard Group 2.
 2. For cartoned, palletized or racked commodities where storage is 4 feet 6 inches or less in height and where the ceiling height does not exceed 18 feet, quantities are those allowed with a minimum sprinkler design density of 0.21 gallon per minute per square foot over the most remote 1,500-square-foot area.
- c. Where wholesale and retail sales or storage areas exceed 50,000 square feet in area, the maximum allowable quantities are allowed to be increased by 2 percent for each 1,000 square feet of area in excess of 50,000 square feet, up to not more than 100 percent of the table amounts. A control area separation is not required. The cumulative amounts, including amounts attained by having an additional control area, shall not exceed 30,000 gallons.

5704.3.6.2 Container capacity. Containers for Class I liquids shall not exceed a capacity of 5 gallons (19 L).

Exception: Metal containers not exceeding 55 gallons (208 L) are allowed to store up to 240 gallons (908 L) of the *maximum allowable quantity per control area* of Class IB and IC liquids in a *control area*. The building shall be equipped throughout with an ~~approved~~ automatic sprinkler system in accordance with Table 5704.3.4.1. The containers shall be provided with plastic caps without cap seals and shall be stored upright. Containers shall not be stacked or stored in racks and shall not be located in areas open to the public.

5705.3.6.2.3 Solvent quantity limits. Solvent quantities shall be limited as follows:

1. Machines without remote solvent reservoirs shall be limited to quantities set forth in Section 5705.3.5.
2. Machines with remote solvent reservoirs using Class I liquids shall be limited to quantities set forth in Section 5705.3.5.
3. Machines with remote solvent reservoirs using Class II liquids shall be limited to 35 gallons (132 L) per machine. The total quantities shall not exceed an aggregate of 240 gallons (908 L) per *control area* in buildings not equipped throughout with an ~~approved~~ automatic sprinkler system and an aggregate of 480 gallons (1817 L) per *control area* in buildings equipped throughout with an ~~approved~~ automatic sprinkler system in accordance with Section 903.3.1.1.
4. Machines with remote solvent reservoirs using Class IIIA liquids shall be limited to 80 gallons (303 L) per machine.

5705.3.7.3 Fire protection. Rooms or buildings classified in accordance with the International Building Code as Group H-2 or H-3 occupancies shall be equipped with an ~~approved automatic fire-extinguishing~~ approved automatic sprinkler system in accordance with Chapter 9.

5705.5 Alcohol-based hand rubs classified as Class I or II liquids. The use of wall-mounted dispensers containing alcohol-based hand rubs classified as Class I or II liquids shall be in accordance with all of the following:

1. The maximum capacity of each dispenser shall be 68 ounces (2 L).
2. The minimum separation between dispensers shall be 48 inches (1219 mm).
3. The dispensers shall not be installed above, below, or closer than 1 inch (25 mm) to an electrical receptacle, switch, appliance, device or other ignition source. The wall space between the dispenser and the floor or intervening counter top shall be free of electrical receptacles, switches, appliances, devices or other ignition sources.
4. Dispensers shall be mounted so that the bottom of the dispenser is not less than 42 inches (1067 mm) and not more than 48 inches (1219 mm) above the finished floor.
5. Dispensers shall not release their contents except when the dispenser is manually activated. Facilities shall be permitted to install and use automatically activated ~~"touch-free"~~ "touch free" alcohol-based hand-rub dispensing devices with the following requirements:

- 5.1. The facility or persons responsible for the dispensers shall test the dispensers each time a new refill is installed in accordance with the manufacturer's care and use instructions.
- 5.2. Dispensers shall be designed and must operate in a manner that ensures accidental or malicious activations of the dispensing device are minimized. At a minimum, all devices subject to or used in accordance with this section shall have the following safety features:
 - 5.2.1. Any activations of the dispenser shall only occur when an object is placed within 4 inches (98 mm) of the sensing device.
 - 5.2.2. The dispenser shall not dispense more than the amount required for hand hygiene consistent with label instructions as regulated by the United States Food and Drug Administration (USFDA).
 - 5.2.3. An object placed within the activation zone and left in place will cause only one activation.
6. Storage and use of alcohol-based hand rubs shall be in accordance with the applicable provisions of Sections 5704 and 5705.
7. Dispensers installed in occupancies with carpeted floors shall only be allowed in smoke compartments or *fire areas* equipped throughout with an ~~approved~~ automatic sprinkler system in accordance with Section 903.3.1.1 or 903.3.1.2.

6003.2.5 Weather protection for highly toxic liquids and ~~solids—outdoor~~ solids—outdoor storage or use. Where overhead weather protection is provided for outdoor storage or use of highly toxic liquids or solids, and the weather protection is attached to a building, the storage or use area shall either be equipped throughout with an ~~approved~~ automatic sprinkler system in accordance with Section 903.3.1.1, or storage or use vessels shall be fire resistive. Weather protection shall be provided in accordance with Section 5004.13 for storage and Section 5005.3.9 for use.

6504.1.1 Storage of incoming material. Where raw material in excess of 25 pounds (11 kg) is received in a building or *fire area*, an ~~approved~~ vented cabinet or approved vented vault equipped with an ~~approved~~ automatic sprinkler system shall be provided for the storage of material.

6004.1.2 Gas cabinets. Gas cabinets containing highly toxic or toxic *compressed gases* shall comply with Section 5003.8.6 and the following requirements:

1. The average ventilation velocity at the face of gas cabinet access ports or windows shall be not less than 200 feet per minute (1.02 m/s) with not less than 150 feet per minute (0.76 m/s) at any point of the access port or window.
2. Gas cabinets shall be connected to an exhaust system.
3. Gas cabinets shall not be used as the sole means of exhaust for any room or area.
4. The maximum number of cylinders located in a single gas cabinet shall not exceed three, except that cabinets containing cylinders not exceeding 1 pound (0.454 kg) net contents are allowed to contain up to 100 cylinders.
5. Gas cabinets required by Section 6004.2 or 6004.3 shall be equipped with an ~~approved~~ automatic sprinkler system in accordance with Section 903.3.1.1. Alternative fire-extinguishing systems shall not be used.

6004.1.3 Exhausted enclosures. Exhausted enclosures containing highly toxic or toxic *compressed gases* shall comply with Section 5003.8.5 and the following requirements:

1. The average ventilation velocity at the face of the enclosure shall be not less than 200 feet per minute (1.02 m/s) with not less than 150 feet per minute (0.76 m/s).
2. Exhausted enclosures shall be connected to an exhaust system.
3. Exhausted enclosures shall not be used as the sole means of exhaust for any room or area.
4. Exhausted enclosures required by Section 6004.2 or 6004.3 shall be equipped with an ~~approved~~ automatic sprinkler system in accordance with Section 903.3.1.1. Alternative fire-extinguishing systems shall not be used.

6004.2.2.6 Gas rooms. Gas rooms shall comply with Section 5003.8.4 and both of the following requirements:

1. The exhaust ventilation from gas rooms shall be directed to an exhaust system.
2. Gas rooms shall be equipped with an ~~approved~~ automatic sprinkler system. Alternative fire-extinguishing systems shall not be used.

6004.3.3 Outdoor storage weather protection for portable tanks and cylinders. Weather protection in accordance with Section 5004.13 shall be provided for portable tanks and cylinders located outdoors and not within gas cabinets or exhausted enclosures. The storage area shall be equipped with an ~~approved~~ automatic sprinkler system in accordance with Section 903.3.1.1.

Exception: An automatic sprinkler system is not required where:

1. All materials under the weather protection structure, including hazardous materials and the containers in which they are stored, are non-combustible.
2. The weather protection structure is located not less than 30 feet (9144 mm) from combustible materials or structures or is separated from such materials or structures using a fire barrier complying with Section 6004.3.2.1.1.

6504.2 Fire protection. The manufacture or storage of articles of cellulose nitrate (pyroxylin) plastic in quantities exceeding 100 pounds (45 kg) shall be located in a building or portion thereof equipped throughout with an ~~approved~~ automatic sprinkler system in accordance with Section 903.3.1.1.

6704.1.3 Waterproof room. Rooms or areas used for the storage of water-reactive solids and liquids shall be constructed in a manner that resists the penetration of water through the use of waterproof materials. Piping carrying water for other than ~~approved~~ automatic sprinkler systems shall not be within such rooms or areas.

B105.3 Water supply for buildings equipped with an automatic sprinkler system. For buildings equipped with an ~~approved~~ automatic sprinkler system, the water supply shall be capable of providing the greater of:

1. The automatic sprinkler system demand, including hose stream allowance.
2. The required fire flow.

**TABLE C102.1
REQUIRED NUMBER AND SPACING OF FIRE HYDRANT Sh**

FIRE-FLOW REQUIREMENT (gpm)	MINIMUM NUMBER OF HYDRANTS	AVERAGE SPACING BETWEEN HYDRANTS^{a, b, c, f, g}(feet)	MAXIMUM DISTANCE FROM ANY POINT ON STREET OR ROAD FRONTAGE TO A HYDRANT^{d, f, g}
1,750 or less	1	500	250
1,751-2,250	2	450	225
2,251-2,750	3	450	225
2,751-3,250	3	400	225
3,251-4,000	4	350	210
4,001-5,000	5	300	180
5,001-5,500	6	300	180
5,501-6,000	6	250	150
6,001-7,000	7	250	150
7,001 or more	8 or more ^e	200	120

For SI: 1 foot = 304.8 mm, 1 gallon per minute = 3.785 L/m.

- a. Reduce by 100 feet for dead-end streets or roads.
- b. Where streets are provided with median dividers that cannot be crossed by fire fighters pulling hose lines, or where arterial streets are provided with four or more traffic lanes and have a traffic count of more than 30,000 vehicles per day, hydrant spacing shall average 500 feet on each side of the street and be arranged on an alternating basis.
- c. Where new water mains are extended along streets where hydrants are not needed for protection of structures or similar fire problems, fire hydrants shall be provided at spacing not to exceed 1,000 feet to provide for transportation hazards.
- d. Reduce by 50 feet for dead-end streets or roads.
- e. One hydrant for each 1,000 gallons per minute or fraction thereof.
- f. A 50-percent spacing increase shall be permitted where the building is equipped throughout with an ~~approved~~ automatic sprinkler system in accordance with Section 903.3.1.1 of the International Fire Code.
- g. A 25-percent spacing increase shall be permitted where the building is equipped throughout with an ~~approved~~ automatic sprinkler system in accordance with Section 903.3.1.2 or 903.3.1.3 of the International Fire Code or Section P2904 of the International Residential Code.
- h. The fire code official is authorized to modify the location, number and distribution of fire hydrants based on site-specific constraints and hazards.

D104.2 Buildings exceeding 62,000 square feet in area. Buildings or facilities having a gross *building area* of more than 62,000 square feet (5760 m²) shall be provided with two separate and *approved* fire apparatus access roads.

Exception: Projects having a gross *building area* of up to 124,000 square feet (11 520 m²) that have a single *approved* fire apparatus access road where all buildings are equipped throughout with ~~approved~~ automatic sprinkler systems.

D106.1 Projects having more than 100 dwelling units. Multiple-family residential projects having more than 100 *dwelling units* shall be equipped throughout with two separate and *approved* fire apparatus access roads.

Exception: Projects having up to 200 *dwelling units* shall have not fewer than one *approved* fire apparatus access road where all buildings, including nonresidential occupancies, are equipped throughout with ~~approved~~ automatic sprinkler systems installed in accordance with Section 903.3.1.1 or 903.3.1.2.

D106.2 Projects having more than 200 dwelling units. Multiple-family residential projects having more than 200 *dwelling units* shall be provided with two separate and *approved* fire apparatus access roads regardless of whether they are equipped with an ~~approved~~ automatic sprinkler system.

D107.1 One- or two-family dwelling residential developments. Developments of one- or two-family *dwelling* where the number of *dwelling units* exceeds 30 shall be provided with two separate and *approved* fire apparatus access roads.

Exceptions:

1. Where there are more than 30 *dwelling units* on a single public or private fire apparatus access road and all *dwelling units* are equipped throughout with an ~~approved~~ automatic sprinkler system in accordance with Section 903.3.1.1, 903.3.1.2 or 903.3.1.3, access from two directions shall not be required.
2. The number of *dwelling units* on a single fire apparatus access road shall not be increased unless fire apparatus access roads will connect with future development, as determined by the *fire code official*.

K102.5.3 Automatic sprinkler system. Chutes shall be equipped with an ~~approved~~ automatic sprinkler system in accordance with Section 903.2.11.2.

N105.4 Automatic sprinkler systems. An ~~approved~~ automatic sprinkler system in accordance with Section 903.3.1.1 shall be provided in multiple-level booths exceeding 400 square feet (37.2 m²) in floor area per level.

N106.1 Automatic sprinkler systems. An ~~approved~~ automatic sprinkler system in accordance with Section 903.3.1.1 of this code shall be provided in covered booths exceeding 100 square feet (9.3 m²) in floor area per level.

[F] TABLE 307.1(2)

MAXIMUM ALLOWABLE QUANTITY PER CONTROL AREA OF HAZARDOUS MATERIALS POSING A HEALTH HAZARD^{a, c, f, h, i}

MATERIAL	STORAGE ^b			USE-CLOSED SYSTEMS ^b		
	Solid pounds ^{d, e}	Liquid gallons (pounds) ^{d, e}	Gas cubic feet at NTP (pounds) ^d	Solid pounds ^d	Liquid gallons (pounds) ^d	Gas cubic feet at NTP (pounds)
Corrosives	5,000	500	Gaseous 810 ^e Liquefied (150)	5,000	500	Gaseous 810 ^e Liquefied (150)
Highly Toxic	10	(10)	Gaseous 20 ^g Liquefied (4) ^g	10	(10)	Gaseous 20 ^g Liquefied (4) ^g
Toxic	500	(500)	Gaseous 810 ^e Liquefied (150) ^e	500	(500)	Gaseous 810 ^e Liquefied (150) ^e

For SI: 1 cubic foot = 0.028 m³, 1 pound = 0.454 kg, 1 gallon = 3.785 L.

- a. For use of control areas, see Section 414.2.
- b. The aggregate quantity in use and storage shall not exceed the quantity listed for storage.
- c. In retail and wholesale sales occupancies, the quantities of medicines, foodstuffs or consumer products, and cosmetics containing not more than 50 percent by volume of water-miscible liquids and with the remainder of the solutions not being flammable, shall not be limited, provided that such materials are packaged in individual containers not exceeding 1.3 gallons.
- d. Maximum allowable quantities shall be increased 100 percent in buildings equipped throughout with an ~~approved~~ automatic sprinkler system in accordance with Section 903.3.1.1. Where Note e also applies, the increase for both notes shall be applied accumulatively.
- e. Maximum allowable quantities shall be increased 100 percent where stored in approved storage cabinets, gas cabinets or exhausted enclosures as specified in the International Fire Code. Where Note d also applies, the increase for both notes shall be applied accumulatively.
- f. For storage and display quantities in Group M and storage quantities in Group S occupancies complying with Section 414.2.5, see Tables 414.2.5(1) and 414.2.5(2).
- g. Allowed only where stored in approved exhausted gas cabinets or exhausted enclosures as specified in the International Fire Code.
- h. Quantities in parentheses indicate quantity units in parentheses at the head of each column.
- i. For gallons of liquids, divide the amount in pounds by 10 in accordance with Section 5003.1.2 of the International Fire Code.

402.6.2 Kiosks. Kiosks and similar structures (temporary or permanent) located within the *mall* of a *covered mall building* or within the perimeter line of an *open mall building* shall meet the following requirements:

1. Combustible kiosks or other structures shall not be located within a *covered* or *open mall* unless constructed of any of the following materials:
 - 1.1. *Fire-retardant-treated* wood complying with Section 2303.2.
 - 1.2. Foam plastics having a maximum heat release rate not greater than 100 kW (105 Btu/h) when tested in accordance with the exhibit booth protocol in UL 1975 or when tested in accordance with NFPA 289 using the 20 kW ignition source.
 - 1.3. Aluminum composite material (ACM) meeting the requirements of Class A *interior finish* in accordance with Chapter 8 when tested as an assembly in the maximum thickness intended.
2. Kiosks or similar structures located within the mall shall be provided with ~~approved~~ automatic *sprinkler system* and detection devices.
3. The horizontal separation between kiosks or groupings thereof and other structures within the *mall* shall be not less than 20 feet (6096 mm).
4. Each kiosk or similar structure or groupings thereof shall have an area not greater than 300 square feet (28 m²).

413.2 Attic, under-floor and concealed spaces. *Attic*, under-floor and concealed spaces used for storage of combustible materials shall be protected on the storage side as required for 1-hour fire-resistance-rated construction. Openings shall be protected by assemblies that are *self-closing* and are of noncombustible construction or solid wood core not less than 1³/₄ inch (45 mm) in thickness.

Exception: Neither fire-resistance-rated construction nor opening protectives are required in any of the following locations:

1. Areas protected by ~~approved~~ automatic *sprinkler systems*.
2. Group R-3 and U occupancies.

[F] TABLE 414.2.5(2)

MAXIMUM ALLOWABLE QUANTITY OF FLAMMABLE AND COMBUSTIBLE LIQUIDS IN WHOLESALE AND RETAIL SALES OCCUPANCIES PER CONTROL AREA^a

TYPE OF LIQUID	MAXIMUM ALLOWABLE QUANTITY PER CONTROL AREA (gallons)		
	Sprinklered in accordance with note b densities and arrangements	Sprinklered in accordance with Tables 5704.3.6.3(4) through 5704.3.6.3(8) and 5704.3.7.5.1 of the International Fire Code	Nonsprinklered
Class IA	60	60	30
Class IB, IC, II and IIIA	7,500 ^c	15,000 ^c	1,600
Class IIIB	Unlimited	Unlimited	13,200

For SI: 1 foot = 304.8 mm, 1 square foot = 0.0929 m², 1 gallon = 3.785 L, 1 gallon per minute per square foot = 40.75 L/min/m².

- a. Control areas shall be separated from each other by not less than a 1-hour fire barrier wall.
- b. To be considered as sprinklered, a building shall be equipped throughout with an ~~approved~~ automatic sprinkler system with a design providing minimum densities as follows:
 1. For uncartoned commodities on shelves 6 feet or less in height where the ceiling height does not exceed 18 feet, quantities are those permitted with a minimum sprinkler design density of Ordinary Hazard Group 2.
 2. For cartoned, palletized or racked commodities where storage is 4 feet 6 inches or less in height and where the ceiling height does not exceed 18 feet, quantities are those permitted with a minimum sprinkler design density of 0.21 gallon per minute per square foot over the most remote 1,500-square-foot area.
- c. Where wholesale and retail sales or storage areas exceed 50,000 square feet in area, the maximum allowable quantities are allowed to be increased by 2 percent for each 1,000 square feet of area in excess of 50,000 square feet, up to not more than 100 percent of the table amounts. A control area separation is not required. The cumulative amounts, including amounts attained by having an additional control area, shall not exceed 30,000 gallons.

[F] 415.11.11 Automatic sprinkler system protection in exhaust ducts for HPM. An ~~approved~~ automatic sprinkler system shall be provided in exhaust ducts conveying gases, vapors, fumes, mists or dusts generated from HPM in accordance with Sections 415.11.11.1 through 415.11.11.3 and the International Mechanical Code.

[F] 415.11.11.1 Metallic and noncombustible nonmetallic exhaust ducts. An ~~approved~~ automatic sprinkler system shall be provided in metallic and noncombustible nonmetallic exhaust ducts where all of the following conditions apply:

1. Where the largest cross-sectional diameter is equal to or greater than 10 inches (254 mm).
2. The ducts are within the building.
3. The ducts are conveying flammable gases, vapors or fumes.

[F] 415.11.2 Corridors. *Corridors* shall comply with Chapter 10 and shall be separated from *fabrication areas* as specified in Section 415.11.1.2. *Corridors* shall not contain HPM and shall not be used for transporting such materials except through closed piping systems as provided in Section 415.11.6.4.

Exception: Where existing *fabrication areas* are altered or modified, HPM is allowed to be transported in existing *corridors*, subject to the following conditions:

1. Nonproduction HPM is allowed to be transported in *corridors* if utilized for maintenance, lab work and testing.
2. Where existing *fabrication areas* are altered or modified, HPM is allowed to be transported in existing *corridors*, subject to the following conditions:
 - 2.1. *Corridors.* *Corridors* adjacent to the *fabrication area* where the alteration work is to be done shall comply with Section 1020 for a length determined as follows:
 - 2.1.1. The length of the common wall of the *corridor* and the *fabrication area*; and
 - 2.1.2. For the distance along the *corridor* to the point of entry of HPM into the *corridor* serving that *fabrication area*.
 - 2.2. *Emergency alarm system.* There shall be an emergency telephone system, a local manual alarm station or other *approved* alarm-initiating device within *corridors* at not more than 150-foot (45 720 mm) intervals and at each exit and doorway. The signal shall be relayed to an *approved* central, proprietary or remote station service or the emergency control station and shall initiate a local audible alarm.
 - 2.3. *Pass-throughs.* *Self-closing* doors having a *fire protection rating* of not less than 1 hour shall separate pass-throughs from existing *corridors*. Pass-throughs shall be constructed as required for the *corridors* and protected by an ~~approved~~ automatic sprinkler system.

[F] 415.8.5 Waterproof room. Rooms or areas used for the storage of water-reactive solids and liquids shall be constructed in a manner that resists the penetration of water through the use of waterproof materials. Piping carrying

water for other than ~~approved~~ *automatic sprinkler systems* shall not be within such rooms or areas.

[F] 428.3.9 Automatic fire-extinguishing sprinkler systems. Buildings containing laboratory suites shall be equipped throughout with an ~~approved~~ *automatic sprinkler system* in accordance with Section 903.3.1.1.

505.2.1 Area limitation. The aggregate area of a *mezzanine* or *mezzanines* within a room shall be not greater than one-third of the floor area of that room or space in which they are located. The enclosed portion of a room shall not be included in a determination of the floor area of the room in which the *mezzanine* is located. In determining the allowable *mezzanine* area, the area of the *mezzanine* shall not be included in the floor area of the room.

~~approved~~

Exceptions:

1. The aggregate area of *mezzanines* in buildings and structures of Type I or II construction for special industrial occupancies in accordance with Section 503.1.1 shall be not greater than two-thirds of the floor area of the room.
2. The aggregate area of *mezzanines* in buildings and structures of Type I or II construction shall be not greater than one-half of the floor area of the room in buildings and structures equipped throughout with an

~~approved~~

1. The aggregate area of *mezzanines* in buildings and structures of Type I or II construction for special industrial occupancies in accordance with Section 503.1.1 shall be not greater than two-thirds of the floor area of the room.
2. The aggregate area of *mezzanines* in buildings and structures of Type I or II construction shall be not greater than one-half of the floor area of the room in buildings and structures equipped throughout with an

1. The aggregate area of *mezzanines* in buildings and structures of Type I or II construction for special industrial occupancies in accordance with Section 503.1.1 shall be not greater than two-thirds of the floor area of the room.
2. The aggregate area of *mezzanines* in buildings and structures of Type I or II construction shall be not greater than one-half of the floor area of the room in buildings and structures equipped throughout with an

automatic sprinkler system in accordance with Section 903.3.1.1 and a n *approved emergency voice/alarm communication system* in accordance with Section 907.5.2.2.

automatic sprinkler system in accordance with Section 903.3.1.1 or 903.3.1.2 shall not be greater than one-half of the floor area of the room, provided that:

automatic sprinkler system in accordance with Section 903.3.1.1 and a n *approved emergency voice/alarm communication system* in accordance with Section 907.5.2.2.

automatic sprinkler system in accordance with Section 903.3.1.1 and a n *approved emergency voice/alarm communication system* in accordance with Section 907.5.2.2.

510.2 Horizontal building separation allowance. A building shall be considered as separate and distinct buildings for the purpose of determining area limitations, continuity of *fire walls*, limitation of number of *stories* and type of construction where all of the following conditions are met:

1. The buildings are separated with a *horizontal assembly* having a *fire-resistance rating* of not less than 3 hours. Where vertical offsets are provided as part of a *horizontal assembly*, the vertical offset and the structure supporting the vertical offset shall have a *fire-resistance rating* of not less than 3 hours.
2. The building below, including the *horizontal assembly*, is of Type IA construction.
3. *Shaft, stairway, ramp* and escalator enclosures through the *horizontal assembly* shall have not less than a 2-hour *fire-resistance rating* with opening protectives in accordance with Section 716.

Exception: Where the enclosure walls below the *horizontal assembly* have not less than a 3-hour *fire-resistance rating* with opening protectives in accordance with Section 716, the enclosure walls extending above the *horizontal assembly* shall be permitted to have a 1-hour *fire-resistance rating*, provided:

1. The building above the *horizontal assembly* is not required to be of Type I construction;

2. The enclosure connects fewer than four *stories*; and
3. The enclosure opening protectives above the *horizontal assembly* have a *fire protection rating* of not less than 1 hour.
4. The building or buildings above the *horizontal assembly* shall be permitted to have multiple Group A occupancy uses, each with an *occupant load* of less than 300, or Group B, M, R or S occupancies.
5. The building below the *horizontal assembly* shall be protected throughout by an approved *automatic sprinkler system* in accordance with Section 903.3.1.1, and shall be permitted to be any occupancy allowed by this code except Group H.
6. The maximum *building height* in feet (mm) shall not exceed the limits set forth in Section 504.3 for the building having the smaller allowable height as measured from the *grade plane*.

713.11 Enclosure at the bottom. Shafts that do not extend to the bottom of the building or structure shall comply with one of the following:

1. They shall be enclosed at the lowest level with construction of the same *fire-resistance rating* as the lowest floor through which the shaft passes, but not less than the rating required for the shaft enclosure.
2. They shall terminate in a room having a use related to the purpose of the shaft. The room shall be separated from the remainder of the building by *fire barriers* constructed in accordance with Section 707 or *horizontal assemblies* constructed in accordance with Section 711, or both. The *fire-resistance rating* and opening protectives shall be not less than the protection required for the shaft enclosure.
3. They shall be protected by *approved fire dampers* installed in accordance with their listing at the lowest floor level within the shaft enclosure.

Exceptions:

1. The fire-resistance-rated room separation is not required, provided that the only openings in or penetrations of the shaft enclosure to the interior of the building occur at the bottom. The bottom of the shaft shall be closed off around the penetrating items with materials permitted by Section 718.3.1 for draftstopping, or the room shall be provided with an ~~approved~~ *automatic sprinkler system*.
2. A shaft enclosure containing a waste or linen chute shall not be used for any other purpose and shall discharge in a room protected in accordance with Section 713.13.4.
3. The fire-resistance-rated room separation and the protection at the bottom of the shaft are not required provided that there are no combustibles in the shaft and there are no openings or other penetrations through the shaft enclosure to the interior of the building.

713.13.6 Automatic sprinkler system. An ~~approved~~ *automatic sprinkler system* shall be installed in accordance with Section 903.2.11.2.

[F] 806.2 Combustible decorative materials. In Groups A, B, E, I, M and R-1 and in dormitories in Group R-2, curtains, draperies, fabric hangings and similar combustible decorative materials suspended from walls or ceilings shall comply with Section 806.4 and shall not exceed 10 percent of the specific wall or ceiling area to which such materials are attached.

Fixed or movable walls and partitions, paneling, wall pads and crash pads applied structurally or for decoration, acoustical correction, surface insulation or other purposes shall be considered to be *interior finish*, shall comply with Section 803 and shall not be considered to be *decorative materials* or furnishings.

Exceptions:

1. In auditoriums in Group A, the permissible amount of curtains, draperies, fabric hangings and similar combustible decorative materials suspended from walls or ceilings shall not exceed 75 percent of the aggregate wall area where the building is equipped throughout with an ~~approved~~ *automatic sprinkler system* in accordance with Section 903.3.1.1, and where the material is installed in accordance with Section 803.15 of this code.
2. In Group R-2 dormitories, within sleeping units and dwelling units, the permissible amount of curtains, draperies, fabric hangings and similar decorative materials suspended from walls or ceiling shall not exceed 50 percent of the aggregate wall areas where the building is equipped throughout with an ~~approved~~ *automatic sprinkler system* installed in accordance with Section

903.3.1.

3. In Group B and M occupancies, the amount of combustible fabric partitions suspended from the ceiling and not supported by the floor shall comply with Section 806.4 and shall not be limited.
4. The 10-percent limit shall not apply to curtains, draperies, fabric hangings and similar combustible decorative materials used as window coverings.

[F] 903.2 Where required. ~~Approved Automatic~~ *automatic sprinkler systems* in new buildings and structures shall be provided in the locations described in Sections 903.2.1 through 903.2.12.

Exception: Spaces or areas in telecommunications buildings used exclusively for telecommunications equipment, associated electrical power distribution equipment, batteries and standby engines, provided that those spaces or areas are equipped throughout with an *automatic smoke detection system* in accordance with Section 907.2 and are separated from the remainder of the building by not less than 1-hour *fire barriers* constructed in accordance with Section 707 or not less than 2-hour *horizontal assemblies* constructed in accordance with Section 711, or both.

[F] 903.2.11.1.2 Openings on one side only. Where openings in a *story* are provided on only one side and the opposite wall of such *story* is more than 75 feet (22 860 mm) from such openings, the *story* shall be equipped throughout with an ~~approved automatic~~ *sprinkler system*, or openings shall be provided on not fewer than two sides of the *story*.

[F] 903.2.11.1.3 Basements. Where any portion of a *basement* is located more than 75 feet (22 860 mm) from openings required by Section 903.2.11.1, or where walls, partitions or other obstructions are installed that restrict the application of water from hose streams, the *basement* shall be equipped throughout with an ~~approved automatic~~ *sprinkler system*.

[F] 905.4.1 Protection. Risers and laterals of Class I standpipe systems not located within an *interior exit stairway* shall be protected by a degree of *fire resistance* equal to that required for vertical enclosures in the building in which they are located.

Exception: In buildings equipped throughout with an ~~approved automatic~~ *sprinkler system*, laterals that are not located within an *interior exit stairway* are not required to be enclosed within fire-resistance-rated construction.

[F] 907.2.3 Group E. A manual fire alarm system that initiates the occupant notification signal utilizing an emergency voice/alarm communication system meeting the requirements of Section 907.5.2.2 and installed in accordance with Section 907.6 shall be installed in Group E occupancies. Where *automatic sprinkler systems* or smoke detectors are installed, such systems or detectors shall be connected to the building fire alarm system.

Exceptions:

1. A manual fire alarm system is not required in Group E occupancies with an *occupant load* of 50 or less.
2. Emergency voice/alarm communication systems meeting the requirements of Section 907.5.2.2 and installed in accordance with Section 907.6 shall not be required in Group E occupancies with occupant loads of 100 or less, provided that activation of the manual fire alarm system initiates an *approved* occupant notification signal in accordance with Section 907.5.
3. Manual fire alarm boxes are not required in Group E occupancies where all of the following apply:
 - 3.1. Interior *corridors* are protected by smoke detectors.
 - 3.2. Auditoriums, cafeterias, gymnasiums and similar areas are protected by *heat detectors* or other *approved* detection devices.
 - 3.3. Shops and laboratories involving dusts or vapors are protected by *heat detectors* or other *approved* detection devices.
4. Manual fire alarm boxes shall not be required in Group E occupancies where all of the following apply:
 - 4.1. The building is equipped throughout with an ~~approved automatic~~ *sprinkler system* installed in accordance with Section 903.3.1.1.
 - 4.2. The emergency voice/alarm communication system will activate on sprinkler waterflow.
 - 4.3. Manual activation is provided from a normally occupied location.

[F] 907.2.9.1 Manual fire alarm system. A manual fire alarm system that activates the occupant notification system in accordance with Section 907.5 shall be installed in Group R-2 occupancies where any of the following

conditions apply:

1. Any *dwelling unit* or *sleeping unit* is located three or more *stories* above the lowest *level of exit discharge*.
2. Any *dwelling unit* or *sleeping unit* is located more than one story below the highest *level of exit discharge* of *exits* serving the *dwelling unit* or *sleeping unit*.
3. The building contains more than 16 *dwelling units* or *sleeping units*.

Exceptions:

1. A fire alarm system is not required in buildings not more than two stories in height where all *dwelling units* or *sleeping units* and contiguous *attic* and crawl spaces are separated from each other and public or common areas by not less than 1-hour *fire partitions* and each *dwelling unit* or *sleeping unit* has an *exit* directly to a *public way*, *egress court* or *yard*.
2. Manual fire alarm boxes are not required where the building is equipped throughout with an *automatic sprinkler system* installed in accordance with Section 903.3.1.1 or 903.3.1.2 and the occupant notification appliances will automatically activate throughout the notification zones upon a sprinkler water flow.
3. A fire alarm system is not required in buildings that do not have interior *corridors* serving dwelling units and are protected by an ~~approved~~ *automatic sprinkler system* installed in accordance with Section 903.3.1.1 or 903.3.1.2, provided that *dwelling units* either have a *means of egress* door opening directly to an exterior *exit access* that leads directly to the exits or are served by open-ended *corridors* designed in accordance with Section 1027.6, Exception 3.

[F] 910.2 Where required. Smoke and heat vents or a mechanical smoke removal system shall be installed as required by Sections 910.2.1 and 910.2.2.

Exceptions:

1. Frozen food warehouses used solely for storage of Class I and II commodities where protected by an *approved automatic sprinkler system*.
2. Smoke and heat removal shall not be required in areas of buildings equipped with early suppression fast-response (ESFR) sprinklers.
3. Smoke and heat removal shall not be required in areas of buildings equipped with control mode special application sprinklers with a response time index of 50 (m · s)^{1/2} or less that are listed to control a fire in stored commodities with 12 or fewer sprinklers.

910.4.1 Automatic sprinklers required. The building shall be equipped throughout with an ~~approved~~ *automatic sprinkler system* in accordance with Section 903.3.1.1.

1006.2.2.3 Refrigerated rooms or spaces. Rooms or spaces having a floor area larger than 1,000 square feet (93 m²), containing a refrigerant evaporator and maintained at a temperature below 68°F (20°C), shall have access to not less than two *exits* or *exit access doorways*.

Exit access travel distance shall be determined as specified in Section 1017.1, but all portions of a refrigerated room or space shall be within 150 feet (45 720 mm) of an *exit* or *exit access doorway* where such rooms are not protected by an ~~approved~~ *automatic sprinkler system*. Egress is allowed through adjoining refrigerated rooms or spaces.

Exception: Where using refrigerants in quantities limited to the amounts based on the volume set forth in the International Mechanical Code.

1010.3.2 Security access turnstiles. Security access turnstiles that inhibit travel in the direction of egress utilizing a physical barrier shall be permitted to be considered as a component of the *means of egress*, provided that all of the following criteria are met:

1. The building is protected throughout by an *automatic sprinkler system* in accordance with Section 903.3.1.1.
2. Each security access turnstile lane configuration has a minimum clear passage width of 22 inches (559 mm).
3. Any security access turnstile lane configuration providing a clear passage width of less than 32 inches (810 mm) shall be credited with a maximum egress capacity of 50 persons.
4. Any security access turnstile lane configuration providing a clear passage width of 32 inches (810

mm) or more shall be credited with a maximum egress capacity as calculated in accordance with Section 1005.

5. Each secured physical barrier shall automatically retract or swing to an unobstructed open position in the direction of egress, under each of the following conditions:
 - 5.1. Upon loss of power to the turnstile or any part of the access control system that secures the physical barrier.
 - 5.2. Upon actuation of a clearly identified manual release device with ready access that results in direct interruption of power to each secured physical barrier, after which such barriers remain in the open position for not less than 30 seconds. The manual release device shall be positioned at one of the following locations:
 - 5.2.1. On the egress side of each security access turnstile lane.
 - 5.2.2. At an *approved* location where it can be actuated by an employee assigned to the area at all times that the building is occupied.
 - 5.3. Upon actuation of the building *fire alarm system*, if provided, after which the physical barrier remains in the open position until the *fire alarm system* is manually reset.

Exception: Actuation of a manual fire alarm box.
 - 5.4. Upon actuation of the building automatic sprinkler or fire detection system, after which the physical barrier remains in the open position until the *fire alarm system* is manually reset.

1028.1 General. *Exits* shall discharge directly to the exterior of the building. The *exit discharge* shall be at grade or shall provide a direct path of egress travel to grade. The *exit discharge* shall not reenter a building. The combined use of Exceptions 1 and 2 shall not exceed 50 percent of the number and minimum width or required capacity of the required *exits*.

Exceptions:

1. Not more than 50 percent of the number and minimum width or required capacity of *interior exit stairways* and *ramps* is permitted to egress through areas on the level of discharge provided that all of the following conditions are met:
 - 1.1. Discharge of *interior exit stairways* and *ramps* shall be provided with a free and unobstructed path of travel to an exterior *exit* door and such *exit* is readily visible and identifiable from the point of termination of the enclosure.
 - 1.2. The entire area of the *level of exit discharge* is separated from areas below by construction conforming to the *fire-resistance rating* for the enclosure.
 - 1.3. The egress path from the *interior exit stairway* and *ramp* on the *level of exit discharge* is protected throughout by an ~~approved~~ *automatic sprinkler system*. Portions of the *level of exit discharge* with access to the egress path shall be either equipped throughout with an *automatic sprinkler system* installed in accordance with Section 903.3.1.1 or 903.3.1.2, or separated from the egress path in accordance with the requirements for the enclosure of *interior exit stairways* or *ramps*.
 - 1.4. Where a required *interior exit stairway* or *ramp* and an *exit access stairway* or *ramp* serve the same floor level and terminate at the same *level of exit discharge*, the termination of the *exit access stairway* or *ramp* and the *exit discharge* door of the *interior exit stairway* or *ramp* shall be separated by a distance of not less than 30 feet (9144 mm) or not less than one-fourth the length of the maximum overall diagonal dimension of the building, whichever is less. The distance shall be measured in a straight line between the *exit discharge* door from the *interior exit stairway* or *ramp* and the last tread of the *exit access stairway* or termination of slope of the *exit access ramp*.
2. Not more than 50 percent of the number and minimum width or required capacity of the *interior exit stairways* and *ramps* is permitted to egress through a vestibule provided that all of the following conditions are met:
 - 2.1. The entire area of the vestibule is separated from areas below by construction conforming to the *fire-resistance rating* of the *interior exit stairway* or *ramp enclosure*.
 - 2.2. The depth from the exterior of the building is not greater than 10 feet (3048 mm) and the length is not greater than 30 feet (9144 mm).
 - 2.3. The area is separated from the remainder of the *level of exit discharge* by a *fire partition*

constructed in accordance with Section 708.

Exception: The maximum transmitted temperature rise is not required.

- 2.4. The area is used only for *means of egress* and *exits* directly to the outside.
3. *Horizontal exits* complying with Section 1026 shall not be required to discharge directly to the exterior of the building.

1029.6.2.3 Automatic sprinklers. Enclosed areas with walls and ceilings in buildings or structures containing *smoke-protected assembly seating* shall be protected with an ~~approved~~ *automatic sprinkler system* in accordance with Section 903.3.1.1.

Exceptions:

1. The floor area used for contests, performances or entertainment provided that the roof construction is more than 50 feet (15 240 mm) above the floor level and the use is restricted to low fire hazard uses.
2. Press boxes and storage facilities less than 1,000 square feet (93 m²) in area.
3. Outdoor seating facilities where seating and the *means of egress* in the seating area are essentially open to the outside.

2603.3 Surface-burning characteristics. Unless otherwise indicated in this section, foam plastic insulation and foam plastic cores of manufactured assemblies shall have a flame spread index of not more than 75 and a smoke-developed index of not more than 450 where tested in the maximum thickness intended for use in accordance with ASTM E84 or UL 723. Loose fill-type foam plastic insulation shall be tested as board stock for the flame spread and smoke-developed indices.

Exceptions:

1. Smoke-developed index for interior *trim* as provided for in Section 2604.2.
2. In cold storage buildings, ice plants, food plants, food processing rooms and similar areas, foam plastic insulation where tested in a thickness of 4 inches (102 mm) shall be permitted in a thickness up to 10 inches (254 mm) where the building is equipped throughout with an automatic fire sprinkler system in accordance with Section 903.3.1.1. The ~~approved~~ *automatic sprinkler system* shall be provided in both the room and that part of the building in which the room is located.
3. Foam plastic insulation that is a part of a Class A, B or C roof-covering assembly provided that the assembly with the foam plastic insulation satisfactorily passes NFPA 276 or UL 1256. The smoke-developed index shall not be limited for roof applications.
4. Foam plastic insulation greater than 4 inches (102 mm) in thickness shall have a maximum flame spread index of 75 and a smoke-developed index of 450 where tested at a minimum thickness of 4 inches (102 mm), provided that the end use is approved in accordance with Section 2603.9 using the maximum thickness and density intended for use.
5. Flame spread and smoke-developed indices for foam plastic interior signs in *covered and open mall buildings* provided that the signs comply with Section 402.6.4.

C102.3 Two-story unlimited area. The area of a two-story Group U agricultural building shall not be limited if the building is surrounded and adjoined by *public ways* or *yards* not less than 60 feet (18 288 mm) in width and is provided with an ~~approved~~ *automatic sprinkler system* throughout in accordance with Section 903.3.1.1.

2018 International Existing Building Code

504.5 Opening protectives. Doors and windows within 10 feet (3048 mm) of fire escape stairways shall be protected with ³/₄-hour opening protectives.

Exception: Opening protection shall not be required in buildings equipped throughout with an ~~approved~~ automatic sprinkler system.

802.2.1 Existing vertical openings. Existing interior vertical openings connecting two or more floors shall be enclosed with *approved* assemblies having a fire-resistance rating of not less than 1 hour with *approved* opening protectives.

Exceptions:

1. Where vertical opening enclosure is not required by the International Building Code or the International Fire Code.
2. Interior vertical openings other than stairways may be blocked at the floor and ceiling of the *work area* by installation of not less than 2 inches (51 mm) of solid wood or equivalent construction.
3. The enclosure shall not be required where:
 - 3.1. Connecting the main floor and mezzanines; or
 - 3.2. All of the following conditions are met:
 - 3.2.1. The communicating area has a low-hazard occupancy or has a moderate-hazard occupancy that is protected throughout by an automatic sprinkler system.
 - 3.2.2. The lowest or next-to-the-lowest level is a street floor.
 - 3.2.3. The entire area is open and unobstructed in a manner such that it is reasonable to assume that a fire in any part of the interconnected spaces will be readily obvious to all of the occupants.
 - 3.2.4. Exit capacity is sufficient to provide egress simultaneously for all occupants of all levels by considering all areas to be a single floor area for the determination of required exit capacity.
 - 3.2.5. Each floor level, considered separately, has not less than one-half of its individual required exit capacity provided by an exit or exits leading directly out of that level without having to traverse another communicating floor level or be exposed to the smoke or fire spreading from another communicating floor level.
4. In Group A occupancies, a minimum 30-minute enclosure shall be provided to protect all vertical openings not exceeding three stories.
5. In Group B occupancies, a minimum 30-minute enclosure shall be provided to protect all vertical openings not exceeding three stories. This enclosure, or the enclosure specified in Section 802.2.1, shall not be required in the following locations:
 - 5.1. Buildings not exceeding 3,000 square feet (279 m²) per floor.
 - 5.2. Buildings protected throughout by an *approved* automatic fire sprinkler system.
6. In Group E occupancies, the enclosure shall not be required for vertical openings not exceeding three stories where the building is protected throughout by an *approved* automatic fire sprinkler system.
7. In Group F occupancies, the enclosure shall not be required in the following locations:
 - 7.1. Vertical openings not exceeding three stories.
 - 7.2. Special-purpose occupancies where necessary for manufacturing operations and direct access is provided to not fewer than one protected stairway.
 - 7.3. Buildings protected throughout by an *approved* automatic sprinkler system.
8. In Group H occupancies, the enclosure shall not be required for vertical openings not exceeding three stories where necessary for manufacturing operations and every floor level has direct access to not fewer than two remote enclosed stairways or other *approved* exits.
9. In Group M occupancies, a minimum 30-minute enclosure shall be provided to protect all vertical openings not exceeding three stories. This enclosure, or the enclosure specified in Section 802.2.1, shall not be required in the following locations:
 - 9.1. Openings connecting only two floor levels.
 - 9.2. Occupancies protected throughout by an *approved* automatic sprinkler system.
10. In Group R-1 occupancies, the enclosure shall not be required for vertical openings not exceeding three stories in the following locations:
 - 10.1. Buildings protected throughout by an *approved* automatic sprinkler system.
 - 10.2. Buildings with less than 25 dwelling units or sleeping units where every sleeping room above the second floor is provided with direct access to a fire escape or other *approved* second exit by means of an *approved* exterior door or window having a sill height of not greater than 44 inches (1118 mm) and where both of the following conditions are met:

- 10.2.1. Any exit access corridor exceeding 8 feet (2438 mm) in length that serves two means of egress, one of which is an unprotected vertical opening, shall have not fewer than one of the means of egress separated from the vertical opening by a 1-hour fire barrier.
- 10.2.2. The building is protected throughout by an automatic fire alarm system, installed and supervised in accordance with the International Building Code.
- 11. In Group R-2 occupancies, a minimum 30-minute enclosure shall be provided to protect all vertical openings not exceeding three stories. This enclosure, or the enclosure specified in Section 802.2.1, shall not be required in the following locations:
 - 11.1. Vertical openings not exceeding two stories with not more than four dwelling units per floor.
 - 11.2. Buildings protected throughout by an *approved* automatic sprinkler system.
 - 11.3. Buildings with not more than four dwelling units per floor where every sleeping room above the second floor is provided with direct access to a fire escape or other *approved* second exit by means of an *approved* exterior door or window having a sill height of not greater than 44 inches (1118 mm) and the building is protected throughout by an automatic fire alarm system complying with Section 803.4.
- 12. One- and two-family dwellings.
- 13. Group S occupancies where connecting not more than two floor levels or where connecting not more than three floor levels and the structure is equipped throughout with an *approved* automatic sprinkler system.
- 14. Group S occupancies where vertical opening protection is not required for open parking garages and ramps.

803.1.1 Corridor ratings. Where an ~~approved~~ automatic sprinkler system is installed throughout the story, the required fire-resistance rating for any corridor located on the story shall be permitted to be reduced in accordance with the International Building Code. In order to be considered for a corridor rating reduction, such system shall provide coverage for the stairway landings serving the floor and the intermediate landings immediately below.

805.3.1.2.1 Fire escape access and details. Fire escapes shall comply with all of the following requirements:

- 1. Occupants shall have unobstructed access to the fire escape without having to pass through a room subject to locking.
- 2. Access to a new fire escape shall be through a door, except that windows shall be permitted to provide access from single dwelling units or sleeping units in Group R-1, R-2 and I-1 occupancies or to provide access from spaces having a maximum occupant load of 10 in other occupancy classifications.
 - 2.1. The window shall have a minimum net clear opening of 5.7 square feet (0.53 m²) or 5 square feet (0.46 m²) where located at grade.
 - 2.2. The minimum net clear opening height shall be 24 inches (610 mm) and net clear opening width shall be 20 inches (508 mm).
 - 2.3. The bottom of the clear opening shall not be greater than 44 inches (1118 mm) above the floor.
 - 2.4. The operation of the window shall comply with the operational constraints of the International Building Code.
- 3. Newly constructed fire escapes shall be permitted only where exterior stairways cannot be utilized because of lot lines limiting the stairway size or because of the sidewalks, alleys, or roads at grade level.
- 4. Openings within 10 feet (3048 mm) of fire escape stairways shall be protected by fire assemblies having minimum ³/₄-hour fire-resistance ratings.

Exception: Opening protection shall not be required in buildings equipped throughout with an ~~approved~~ automatic sprinkler system.
- 5. In all buildings of Group E occupancy, up to and including the 12th grade, buildings of Group I occupancy, rooming houses and childcare centers, ladders of any type are prohibited on fire escapes used as a required means of egress.

805.5.1 Corridor doors. Corridor doors in the *work area* shall not be constructed of hollow core wood and shall not contain louvers. Dwelling unit or sleeping unit corridor doors in *work areas* in buildings of Groups R-1, R-2, and I-1 shall be not less than 1³/₈-inch (35 mm) solid core wood or *approved* equivalent and shall not have any glass panels, other than *approved* wired glass or other *approved* glazing material in metal frames. Dwelling unit or sleeping unit corridor doors in *work areas* in buildings of Groups R-1, R-2, and I-1 shall be equipped with *approved* door closers. Replacement doors shall be 1³/₄-inch (44 mm) solid bonded wood core or *approved* equivalent, unless the existing frame will accommodate only a 1³/₈-inch (35 mm) door.

Exceptions:

1. Corridor doors within a dwelling unit or sleeping unit.
2. Existing doors meeting the requirements of *Guidelines on Fire Ratings of Archaic Materials and Assemblies* (IEBC Resource A) for a rating of 15 minutes or more shall be accepted as meeting the provisions of this requirement.
3. Existing doors in buildings protected throughout with an *approved* automatic sprinkler system shall be required only to resist smoke, be reasonably tight fitting, and shall not contain louvers.
4. In group homes with not more than 15 occupants and that are protected with an *approved* automatic detection system, closing devices are not required.
5. Door assemblies having a fire protection rating of not less than 20 minutes.

1011.7.3 Other vertical shafts. Interior vertical shafts other than stairways, including but not limited to elevator hoistways and service and utility shafts, shall be enclosed as required by the International Building Code where there is a change of use to a higher-hazard category as specified in Table 1011.4.

Exceptions:

1. Existing 1-hour interior shaft enclosures shall be accepted where a higher rating is required.
2. Vertical openings, other than stairways, in buildings of other than Group I occupancy and connecting less than six stories shall not be required to be enclosed if the entire building is provided with an ~~*approved*~~ automatic sprinkler system.

1204.4 Occupancy separation. Required occupancy separations of 1 hour may be omitted where the building is provided with an ~~*approved*~~ automatic sprinkler system throughout.

Reason:

The I codes define that an automatic sprinkler system (*italicized*) is installed according to a referenced standard. The installation standards, NFPA 13, NFPA 13R, and NFPA 13D, are all referenced by the code and are all enforced. Having *approved* (*italicized*) as a defined term in front of another defined term, automatic sprinkler system (*italicized*) implies another level or step for approval. When the I code text states, "approved automatic sprinkler system" , it appears that the installation standard or actual installation has to be approved again by the code official. Removing *approved* in front of another defined term does not remove any authority from the code official, furthermore, the code is inconsistent in the use of *approved* automatic sprinkler system and automatic sprinkler system throughout all of the I codes. This proposal seeks to make the I code documents consistent.

Cost Impact

The code change proposal will decrease the cost of construction .

Removing *approved* decreases the cost of construction as it saves time when interpreting the code.

Internal ID: 196

F41-18

IFC: 503.2.2

Proponent: Kevin Duerr-Clark, representing New York State Department of State (kevin.duerr-clark@dos.ny.gov)

2018 International Fire Code

Revise as follows:

503.2.2 Authority. The *fire code official* shall have the authority to ~~require or permit modifications~~ modify the required access widths of fire apparatus access roads in accordance with one of the following:

1. To require an increase to the required access widths where they are inadequate for fire or rescue operations or where necessary to meet the public safety objectives of the jurisdiction.
2. To permit a decrease to the required access widths where necessary provided that any such decreased access width is sufficient for fire or rescue operations.

Reason:

The 2015 codes changed “increase” to “modifications” and added the “or where necessary to meet the public safety objectives of the jurisdiction.” Additionally, the 2015 commentary states:

“Fire departments respond to many types of emergency situations and the jurisdictions they serve may have traffic safety criteria that impact the design of access roadways used by emergency response vehicles. This section authorizes the fire code official to require greater, or to allow lesser, access-width dimensions based on the size and maneuverability of the anticipated emergency response apparatus, including mutual-aid apparatus from neighboring communities or agencies, among other considerations.”

This proposal is intended to clarify the changes made to this code section in 2015. By changing it to specifically allow an increase or decrease, it makes it clear the intent was to now allow a decrease as well as an increase. The change also ensures the overall goal is to maintain sufficient access to the buildings, regardless of whether the change is an increase or a decrease. Lastly, to meet the public safety objectives was isolated to the increase option only as the proposed change now simply permits the decrease for any reason provided access is still sufficient. This minimizes the chances of misusing this exception by decreasing the fire safety and access to a building in lieu of some other public safety provision.

The example used to defend this proposed change was a jurisdiction wanting to decrease the width of the access road to allow for sidewalks and a tree lawn. The way the code is currently written, one could argue that the jurisdiction has a public safety objective to provide sidewalks, therefore, is justified in the decrease. It does not require them to verify the fire safety objectives are maintained or that access is still sufficient. With this change, however, the jurisdiction will need to justify that the decrease will still provide sufficient access and the fire safety objectives

Cost Impact

The code change proposal will not increase or decrease the cost of construction .

This proposal simply clarifies a provision that already existed.

Internal ID: 1640

F42-18

IFC: 508.1, 508.1.1, 508.1.3, 508.1.7 (New); IBC: [F]911.1, [F]911.1.1, [F]911.1.3, [F] 911.7 (New)

Proponent: Adria Reinertson, Riverside County Fire Department, representing Riverside County Fire Department, California Fire Chiefs Association (adriar@moval.org)

2018 International Fire Code

Revise as follows:

508.1 General. Where required by other sections of this code and in all buildings classified as high-rise buildings by the International Building Code and in all F-1 and S-1 Occupancies with a building footprint of over 500,000 square feet, a fire command center for fire department operations shall be provided and shall comply with Sections 508.1.1 through ~~508.1.6-508.1.7~~

508.1.1 Location and access. ~~The location and accessibility of the fire command center shall be approved by the fire code official.~~ shall be provided with access from fire apparatus access roads and shall have direct access from the building exterior at the lowest level of fire department access.

508.1.3 Size. The fire command center shall be not less than 0.015 percent of the total building area of the facility served or 200 square feet (19 m²) in area, whichever is greater, with a minimum dimension of 0.7 times the square root of the room area or 10 feet (3048 mm), whichever is greater.

Where a fire command is required for Group F-1 and S-1 occupancies with a building footprint greater than 500,000 square feet in area the fire command center shall have a minimum size of 96 square feet (9 m²) with a minimum dimension of 8 feet (2348 mm) where approved by the fire code official.

Add new text as follows:

508.1.7 Fire command center identification. The fire command center shall be identified by a permanent easily visible sign stating "Fire Command Center" located on the door to the fire command center.

2018 International Building Code

[F] 911.1 General. Where required by other sections of this code and in buildings classified as high-rise buildings by this code and in all F-1 and S-1 Occupancies with a building footprint of over 500,000 square feet a fire command center for fire department operations shall be provided and shall comply with Sections 911.1.1 through ~~911.1.6-911.1.7~~.

[F] 911.1.1 Location and access. ~~The location and accessibility of the fire command center shall be approved by the fire code official.~~ provided with access from fire apparatus access roads and shall have direct access from the building exterior at the lowest level of fire department access.

[F] 911.1.3 Size. The room shall be not less than 200 square feet (19 m²) with a minimum dimension of 10 feet (3048 mm).

Where a fire command is required for Group F-1 and S-1 occupancies with a building footprint greater than 500,000 square feet in area the fire command center shall have a minimum size of 96 square feet (9 m²) with a minimum dimension of 8 feet (2348 mm) where approved by the fire code official.

[F] 911.7 Fire command center identification. The fire command center shall be identified by a permanent easily visible sign stating "Fire Command Center" located on the door to the fire command center.

Reason:

Fire Operations at large, horizontal buildings in excess of 500,000 square feet can be just as challenging for firefighters as operating at high-rise buildings. Adding a fire control room to these types of buildings will allow the incident commander to see at a glance, in one protected location, where the fire is, the building layout, and any active fire protection to provide the best strategy possible to mitigate the problem and protect the lives of firefighters. The items required in the fire control room in Section 508.1.6 would be limited to those already in the building and would not require items otherwise not required by the construction of the building.

Section 508.1, 508.1.3, and 508.1.6: These sections have been amended to require fire command centers for structures larger than 500,000 square feet in size. To put into context, the Fire Command Center would be triggered when the buildings are approximately 5 times the typical Costco Warehouse store and approximately 3 times the size of a typical Walmart Supercenter. Large structures of this size pose numerous challenges to emergency responders due to

the large amounts of fuel loads from the storage, manufacturing and/or processing of flammable/combustible commodities and other processes within the building. Challenges include wide distribution of smoke throughout the structure, difficulty for firefighters to locate and reach the fire and difficulty in search and evacuation of the public, employees and firefighters. These structures typically require numerous fire protection, early suppression and detection systems that may include, but are not limited to, fire pumps, multiple fire sprinkler systems, advanced fire alarm systems, smoke control systems, and refrigeration gas detection system(s). During a fire, the incident commander must have the ability to readily identify the status of the various suppression and detection systems and have access to other building information details that may include, but are not limited to, building floor plans, high-pile/rack storage details, smoke control/ventilation systems, fire sprinkler zoning details, mechanical refrigeration equipment and piping details, and hazardous materials data sheets along with quantities and storage/use locations. A fire command center provides a centralized location for the incident commander to review details about the building and the incident and to effectively coordinate emergency responders and suppression activities with increased efficiency and speed. The Riverside County Fire Department has experienced several incidents in buildings with and without Fire Command Centers. Incident Commanders found that having detailed information on built in fire protection systems and controls, building schematics and hazardous materials storage plans were vital towards mitigating the event. When this information was not available, firefighting personnel were forced to operate upon assumptions and much less information. In addition, this increased efficiency and speed results in facilities returning to operation more expeditiously after incidents or false alarms thereby reducing loss of revenue for the business.

Section 508.1.1 & 508.1.8: These sections are added to identify the approved location of the fire command center and to indicate signage requirements for the entrance door.

Cost Impact

The code change proposal will increase the cost of construction .

This proposal would require that a 96 square foot rated room be added to the building, an estimated .06% increase to the cost of construction, utilizing 500,000 square feet as the model. The applicable items listed in 508.1.6 will already be in the building so the cost to locate them in the fire command center rather than throughout the building will not increase costs.

Internal ID: 672

F43-18

IFC: 508.1.6; IBC: 911.1.6

Proponent: Kevin Brinkman, representing National Elevator Industry, Inc. (klbrinkman@neii.org)

2018 International Fire Code

Revise as follows:

508.1.6 Required features. The *fire command center* shall comply with NFPA 72 and shall contain the following features:

1. The emergency voice/alarm communication system control unit.
2. The fire department communications system.
3. Fire detection and alarm system annunciator.
4. Annunciator unit visually indicating the location of the elevators and whether they are operational.
5. Status indicators and controls for air distribution systems.
6. The fire fighter's control panel required by Section 909.16 for smoke control systems installed in the building.
7. Controls for unlocking *interior exit stairway* doors simultaneously.
8. Sprinkler valve and water-flow detector display panels.
9. Emergency and standby power status indicators.
10. A telephone for fire department use with controlled access to the public telephone system.
11. Fire pump status indicators.
12. Schematic building plans indicating the typical floor plan and detailing the building core, *means of egress, fire protection systems, fire-fighter air-replenishment systems, fire-fighting equipment and fire department access, and the location of fire walls, fire barriers, fire partitions, smoke barriers and smoke partitions.*
13. An *approved* Building Information Card that includes, but is not limited to, all of the following information:
 - 13.1. General building information that includes: property name, address, the number of floors in the building above and below grade, use and occupancy classification (for mixed uses, identify the different types of occupancies on each floor) and the estimated building population during the day, night and weekend;
 - 13.2. Building emergency contact information that includes: a list of the building's emergency contacts including but not limited to building manager, building engineer and their respective work phone number, cell phone number and e-mail address;
 - 13.3. Building construction information that includes: the type of building construction including but not limited to floors, walls, columns and roof assembly;
 - 13.4. *Exit access stairway* and *exit stairway* information that includes: number of *exit access stairways* and *exit stairways* in building; each *exit access stairway* and *exit stairway* designation and floors served; location where each *exit access stairway* and *exit stairway* discharges, *interior exit stairways* that are pressurized; *exit stairways* provided with emergency lighting; each *exit stairway* that allows reentry; *exit stairways* providing roof access; elevator information that includes: number of elevator banks, elevator bank designation, elevator car numbers and respective floors that they serve; location of elevator machine rooms, control rooms and control spaces; location of sky lobby; and location of freight elevator banks;
 - 13.5. Building services and system information that includes: location of mechanical rooms, location of building management system, location and capacity of all fuel oil tanks, location of emergency generator and location of natural gas service;
 - 13.6. *Fire protection system* information that includes: location of standpipes, location of fire pump room, location of fire department connections, floors protected by automatic sprinklers and location of different types of *automatic sprinkler systems* installed including but not limited to dry, wet and pre-action;

- 13.7. Hazardous material information that includes: location and quantity of hazardous material.
14. Work table.
15. Generator supervision devices, manual start and transfer features.
16. Public address system, where specifically required by other sections of this code.
17. Elevator fire recall switch in accordance with ASME A17.1/CSA B44.
18. Elevator emergency or standby power selector switch(es) (labelled "elevator emergency power"), where emergency or standby building power is provided and the emergency or standby building power is provided-not sufficient to operate all elevators and associated equipment simultaneously.

2018 International Building Code

Revise as follows:

[F] 911.1.6 Required features. The fire command center shall comply with NFPA 72 and shall contain all of the following features:

1. The emergency voice/alarm communication system control unit.
2. The fire department communications system.
3. Fire detection and alarm system annunciator.
4. Annunciator unit visually indicating the location of the elevators and whether they are operational.
5. Status indicators and controls for air distribution systems.
6. The fire fighter's control panel required by Section 909.16 for smoke control systems installed in the building.
7. Controls for unlocking *interior exit stairway* doors simultaneously.
8. Sprinkler valve and waterflow detector display panels.
9. Emergency and standby power status indicators.
10. A telephone for fire department use with controlled access to the public telephone system.
11. Fire pump status indicators.
12. Schematic building plans indicating the typical floor plan and detailing the building core, *means of egress*, fire protection systems, fire fighter air replenishment system, fire-fighting equipment and fire department access and the location of *fire walls, fire barriers, fire partitions, smoke barriers* and smoke partitions.
13. An *approved* Building Information Card that contains, but is not limited to, the following information:
 - 13.1. General building information that includes: property name, address, the number of floors in the building above and below grade, use and occupancy classification (for mixed uses, identify the different types of occupancies on each floor), and the estimated building population during the day, night and weekend.
 - 13.2. Building emergency contact information that includes: a list of the building's emergency contacts including but not limited to building manager and building engineer and their respective work phone number, cell phone number, e-mail address.
 - 13.3. Building construction information that includes: the type of building construction including but not limited to floors, walls, columns, and roof assembly.
 - 13.4. *Exit access* and *exit stairway* information that includes: number of *exit access* and *exit stairways* in the building, each *exit access* and *exit stairway* designation and floors served, location where each *exit access* and *exit stairway* discharges, *interior exit stairways* that are pressurized, *exit stairways* provided with emergency lighting, each *exit stairway* that allows reentry, *exit stairways* providing roof access; elevator information that includes: number of elevator banks, elevator bank designation, elevator car numbers and respective floors that they serve; location of elevator machine rooms, control rooms and control spaces; location of sky lobby, location of freight elevator banks.
 - 13.5. Building services and system information that includes: location of mechanical rooms, location of building management system, location and capacity of all fuel oil tanks, location of emergency generator, location of natural gas service.

- 13.6. Fire protection system information that includes: location of standpipes, location of fire pump room, location of fire department connections, floors protected by automatic sprinklers, location of different types of *automatic sprinkler systems* installed including, but not limited to, dry, wet and pre-action.
- 13.7 Hazardous material information that includes: location of hazardous material, quantity of hazardous material.
14. Work table.
15. Generator supervision devices, manual start and transfer features.
16. Public address system, where specifically required by other sections of this code.
17. Elevator fire recall switch in accordance with ASME A17.1/BSA 44.
18. Elevator emergency or standby power selector switch(es) (labelled "elevator emergency power"), where emergency or standby building power is provided.~~provided and the emergency or standby building power is provided~~ not sufficient to operate all elevators and associated equipment simultaneously.

Reason:

To clarify that no switch is needed if the emergency or standby power is sufficient to operate all elevators and associated equipment simultaneously.

Cost Impact

The code change proposal will not increase or decrease the cost of construction .

No change to cost since it is a clarification

Internal ID: 1448

F44-18

IFC: 508.1.6; IBC: 911.1.6

Proponent: David Kerr, Knox Company, representing Knox Company

2018 International Fire Code

Revise as follows:

508.1.6 Required features. The *fire command center* shall comply with NFPA 72 and shall contain the following features:

1. The emergency voice/alarm communication system control unit.
2. The fire department communications system.
3. Fire detection and alarm system annunciator.
4. Annunciator unit visually indicating the location of the elevators and whether they are operational.
5. Status indicators and controls for air distribution systems.
6. The fire fighter's control panel required by Section 909.16 for smoke control systems installed in the building.
7. Controls for unlocking *interior exit stairway* doors simultaneously.
8. Sprinkler valve and water-flow detector display panels.
9. Emergency and standby power status indicators.
10. A telephone for fire department use with controlled access to the public telephone system.
11. Fire pump status indicators.
12. Schematic building plans indicating the typical floor plan and detailing the building core, *means of egress, fire protection systems, fire-fighter air-replenishment systems, fire-fighting equipment and fire department access, and the location of fire walls, fire barriers, fire partitions, smoke barriers and smoke partitions.*
13. An *approved* Building Information Card that includes, but is not limited to, all of the following information:
 - 13.1. General building information that includes: property name, address, the number of floors in the building above and below grade, use and occupancy classification (for mixed uses, identify the different types of occupancies on each floor) and the estimated building population during the day, night and weekend;
 - 13.2. Building emergency contact information that includes: a list of the building's emergency contacts including but not limited to building manager, building engineer and their respective work phone number, cell phone number and e-mail address;
 - 13.3. Building construction information that includes: the type of building construction including but not limited to floors, walls, columns and roof assembly;
 - 13.4. *Exit access stairway* and *exit stairway* information that includes: number of *exit access stairways* and *exit stairways* in building; each *exit access stairway* and *exit stairway* designation and floors served; location where each *exit access stairway* and *exit stairway* discharges, *interior exit stairways* that are pressurized; *exit stairways* provided with emergency lighting; each *exit stairway* that allows reentry; *exit stairways* providing roof access; elevator information that includes: number of elevator banks, elevator bank designation, elevator car numbers and respective floors that they serve; location of elevator machine rooms, control rooms and control spaces; location of sky lobby; and location of freight elevator banks;
 - 13.5. Building services and system information that includes: location of mechanical rooms, location of building management system, location and capacity of all fuel oil tanks, location of emergency generator and location of natural gas service;
 - 13.6. *Fire protection system* information that includes: location of standpipes, location of fire pump room, location of fire department connections, floors protected by automatic sprinklers and location of different types of *automatic sprinkler systems* installed including but not limited to dry, wet and pre-action;

- 13.7. Hazardous material information that includes: location and quantity of hazardous material.
- 14. Work table.
- 15. Generator supervision devices, manual start and transfer features.
- 16. Public address system, where specifically required by other sections of this code.
- 17. Elevator fire recall switch in accordance with ASME A17.1/CSA B44.
- 18. Elevator emergency or standby power selector switch(es), where emergency or standby power is provided.
- 19. A locking document storage cabinet of an approved type listed in accordance with UL 1037 to safely secure the required plans and Building Information Card outlined above.

2018 International Building Code

[F] 911.1.6 Required features. The fire command center shall comply with NFPA 72 and shall contain all of the following features:

- 1. The emergency voice/alarm communication system control unit.
- 2. The fire department communications system.
- 3. Fire detection and alarm system annunciator.
- 4. Annunciator unit visually indicating the location of the elevators and whether they are operational.
- 5. Status indicators and controls for air distribution systems.
- 6. The fire fighter's control panel required by Section 909.16 for smoke control systems installed in the building.
- 7. Controls for unlocking *interior exit stairway* doors simultaneously.
- 8. Sprinkler valve and waterflow detector display panels.
- 9. Emergency and standby power status indicators.
- 10. A telephone for fire department use with controlled access to the public telephone system.
- 11. Fire pump status indicators.
- 12. Schematic building plans indicating the typical floor plan and detailing the building core, *means of egress*, fire protection systems, fire fighter air replenishment system, fire-fighting equipment and fire department access and the location of *fire walls*, *fire barriers*, *fire partitions*, *smoke barriers* and smoke partitions.
- 13. An *approved* Building Information Card that contains, but is not limited to, the following information:
 - 13.1. General building information that includes: property name, address, the number of floors in the building above and below grade, use and occupancy classification (for mixed uses, identify the different types of occupancies on each floor), and the estimated building population during the day, night and weekend.
 - 13.2. Building emergency contact information that includes: a list of the building's emergency contacts including but not limited to building manager and building engineer and their respective work phone number, cell phone number, e-mail address.
 - 13.3. Building construction information that includes: the type of building construction including but not limited to floors, walls, columns, and roof assembly.
 - 13.4. *Exit access* and *exit stairway* information that includes: number of *exit access* and *exit stairways* in the building, each *exit access* and *exit stairway* designation and floors served, location where each *exit access* and *exit stairway* discharges, *interior exit stairways* that are pressurized, *exit stairways* provided with emergency lighting, each *exit stairway* that allows reentry, *exit stairways* providing roof access; elevator information that includes: number of elevator banks, elevator bank designation, elevator car numbers and respective floors that they serve; location of elevator machine rooms, control rooms and control spaces; location of sky lobby, location of freight elevator banks.
 - 13.5. Building services and system information that includes: location of mechanical rooms, location of building management system, location and capacity of all fuel oil tanks, location of emergency generator, location of natural gas service.

- 13.6. Fire protection system information that includes: location of standpipes, location of fire pump room, location of fire department connections, floors protected by automatic sprinklers, location of different types of *automatic sprinkler systems* installed including, but not limited to, dry, wet and pre-action.
- 13.7 Hazardous material information that includes: location of hazardous material, quantity of hazardous material.
14. Work table.
15. Generator supervision devices, manual start and transfer features.
16. Public address system, where specifically required by other sections of this code.
17. Elevator fire recall switch in accordance with ASME A17.1/BSA 44.
18. Elevator emergency or standby power selector switch(es), where emergency or standby power is provided.
19. A locking document storage cabinet of an approved type listed in accordance with UL 1037 to safely secure the required plans and Building Information Card outlined above.

Reason:

This section requires immediate access to certain plans and documents necessary for use by responding emergency personnel. The securing of these documents is currently not required by the code. Once the documents are given to the owner, they either never make it to the command center or they are lost within the first year of operation. As building owners and plant engineers change, plans can all most never be replaced and thus cannot be relied upon to be available to responding emergency personnel. The document storage cabinet can also house important keys necessary to operate control features within the fire command center such as smoke control and elevator control systems. Material safety data sheets are often needed immediately upon arrival. Relying on computer systems has in some cases proven to be unreliable. In most cases fire service personnel do not have passwords or often time access rights to the system or the ability to navigate the system in a timely manor. Most buildings of this nature do not have 24 hour plant engineers on site to assist with gathering this critical information. The document storage cabinet shall be of an approved type listed in accordance with UL 1037 to provide antitheft protection for the documents.

Cost Impact

The code change proposal will increase the cost of construction .

The estimated cost of a document storage cabinet is \$900.00

Internal ID: 1447

F45-18

IFC: 105.7.6, 510, 510.1, 510.2, 510.3, 510.4, 510.4.1, 510.4.2, 510.4.2.1, 510.4.2.2, 510.4.2.3, 510.4.2.4, 510.4.2.5, 510.4.2.6, 510.4.2.7, 510.4.2.8, 510.5, 510.5.3, 510.5.4, 510.6, 510.6.1, 510.6.2, 510.6.3, 907.2.12.2, 914.3.6, 1103.2, 1203.2.3; IBC: [F]403.4.5, [F]907.2.12.2, [F]918, [F]918.1, [F]2702.2.3

Proponent: Kevin Scott, representing KH Scott & Associates LLC (khscottassoc@gmail.com)

2018 International Fire Code

Revise as follows:

SECTION 510 EMERGENCY RESPONDER RADIO COMMUNICATION COVERAGE

510.1 Emergency responder radio communication coverage in new buildings. ~~New buildings shall have approved radio~~ Emergency communication coverage for emergency responders shall be provided in all new buildings. Emergency communication coverage within the building shall be based on the existing coverage levels of the public safety communication systems utilized by the jurisdiction, measured at the exterior of the building. This section shall not require improvement of the existing public safety communication systems.

Exceptions:

1. Where *approved* by the building official and the *fire code official*, a wired communication system in accordance with Section 907.2.12.2 shall be permitted to be installed or maintained instead of an *approved* radio coverage system.
2. Where it is determined by the *fire code official* that the radio coverage system is not needed.
3. In facilities where emergency responder radio coverage is required and such systems, components or equipment required could have a negative impact on the normal operations of that facility, the *fire code official* shall have the authority to accept an automatically activated emergency responder radio coverage system.

510.2 Emergency responder radio communication coverage in existing buildings. Existing buildings shall be provided with ~~approved radio~~ emergency communication coverage for emergency responders as required in Chapter 11.

510.3 Permit required. A construction permit for the installation of or modification to emergency ~~responder radio~~ communication coverage systems and related equipment is required as specified in Section 105.7.6. Maintenance performed in accordance with this code is not considered a modification and does not require a permit.

510.4 Technical requirements. Systems, components and equipment required to provide the emergency ~~responder radio~~ communication coverage system shall comply with Sections 510.4.1 through 510.4.2.8.

510.4.1 Emergency responder communication enhancement coverage system signal strength. The building shall be considered to have acceptable emergency ~~responder communications enhancement~~ communication system coverage when signal strength measurements in 95 percent of all areas on each floor of the building meet the signal strength requirements in Sections 510.4.1.1 through 510.4.1.3.

510.4.2 System design. The emergency ~~responder radio~~ communication coverage system shall be designed in accordance with Sections 510.4.2.1 through 510.4.2.8 and NFPA 1221.

510.4.2.1 Amplification systems and components. Buildings and structures that cannot support the required level of ~~radio~~ emergency communication coverage shall be equipped with systems and components to enhance the ~~public safety~~ radio signals and achieve the required level of ~~radio~~ emergency communication coverage specified in Sections 510.4.1 through 510.4.1.3. ~~Public safety communications enhancement~~ Emergency communication systems utilizing radio-frequency-emitting devices and cabling shall be approved by the *fire code official*. Prior to installation, all RF-emitting devices shall have the certification of the radio licensing authority and be suitable for public safety use.

510.4.2.2 Technical criteria. The *fire code official* shall maintain a document providing the specific technical information and requirements for the emergency ~~responder communications~~ communication coverage system. This document shall contain, but not be limited to, the various frequencies required, the location of radio sites, the effective radiated power of radio sites, the maximum propagation delay in microseconds, the applications being used and other supporting technical information necessary for system design.

510.4.2.3 Standby power. Emergency ~~responder radio communication coverage~~ systems shall be provided with dedicated standby batteries or provided with 2-hour standby batteries and connected to the facility generator power system in accordance with Section 1203. The standby power supply shall be capable of operating the emergency ~~responder radio communication coverage~~ system at 100-percent system capacity for a duration of not less than 12 hours.

510.4.2.4 Signal booster requirements. If used, signal boosters shall meet the following requirements:

1. All signal booster components shall be contained in a National Electrical Manufacturer's Association (NEMA) 4-type waterproof cabinet.
2. Battery systems used for the emergency power source shall be contained in a NEMA 3R or higher-rated cabinet.
3. Equipment shall have FCC or other radio licensing authority certification and be suitable for public safety use prior to installation.
4. Where a donor antenna exists, isolation shall be maintained between the donor antenna and all inside antennas to not less than 20dB greater than the system gain under all operating conditions.
5. Bi-Directional Amplifiers (BDAs) used in emergency ~~responder radio communication coverage~~ systems shall have oscillation prevention circuitry.
6. The installation of amplification systems or systems that operate on or provide the means to cause interference on any emergency ~~responder radio communication coverage networks-network~~ shall be coordinated and approved by the *fire code official*.

510.4.2.5 System monitoring. The emergency ~~responder radio enhancement communication coverage~~ system shall be monitored by a listed *fire alarm control unit*, or where approved by the *fire code official*, shall sound an audible signal at a constantly attended on-site location. Automatic supervisory signals shall include the following:

1. Loss of normal AC power supply.
2. System battery charger(s) failure.
3. Malfunction of the donor antenna(s).
4. Failure of active RF-emitting device(s).
5. Low-battery capacity at 70-percent reduction of operating capacity.
6. Failure of critical system components.
7. The communications link between the *fire alarm system* and the emergency ~~responder radio enhancement communication coverage~~ system.

510.4.2.6 Additional frequencies and change of frequencies. The emergency ~~responder radio communication coverage~~ system shall be capable of modification or expansion in the event frequency changes are required by the FCC or other radio licensing authority, or additional frequencies are made available by the FCC or other radio licensing authority.

510.4.2.7 Design documents. The *fire code official* shall have the authority to require "as built" design documents and specifications for emergency ~~responder communications communication coverage~~ systems. The documents shall be in a format acceptable to the *fire code official*.

510.4.2.8 Radio communication antenna density. Systems shall be engineered to minimize the near-far effect. ~~Radio enhancement~~ Emergency communication coverage system designs shall include sufficient antenna density to address reduced gain conditions.

Exceptions:

1. Class A narrow band signal booster devices with independent AGC/ALC circuits per channel.
2. Systems where all portable devices within the same band use active power control features.

510.5 Installation requirements. The installation of the ~~public safety radio emergency communication coverage~~ system shall be in accordance with NFPA 1221 and Sections 510.5.1 through 510.5.4.

510.5.3 Acceptance test procedure. Where an emergency ~~responder radio communication coverage~~ system is required, and upon completion of installation, the building *owner* shall have the radio system tested to verify that two-

way coverage on each floor of the building is not less than 95 percent. The test procedure shall be conducted as follows:

1. Each floor of the building shall be divided into a grid of 20 approximately equal test areas.
2. The test shall be conducted using a calibrated portable radio of the latest brand and model used by the agency talking through the agency's radio communications system or equipment approved by the fire code official.
3. Failure of more than one test area shall result in failure of the test.
4. In the event that two of the test areas fail the test, in order to be more statistically accurate, the floor shall be permitted to be divided into 40 equal test areas. Failure of not more than two nonadjacent test areas shall not result in failure of the test. If the system fails the 40-area test, the system shall be altered to meet the 95-percent coverage requirement.
5. A test location approximately in the center of each test area shall be selected for the test, with the radio enabled to verify two-way communications to and from the outside of the building through the public agency's radio communications system. Once the test location has been selected, that location shall represent the entire test area. Failure in the selected test location shall be considered to be a failure of that test area. Additional test locations shall not be permitted.
6. The gain values of all amplifiers shall be measured and the test measurement results shall be kept on file with the building *owner* so that the measurements can be verified during annual tests. In the event that the measurement results become lost, the building *owner* shall be required to rerun the acceptance test to reestablish the gain values.
7. As part of the installation, a spectrum analyzer or other suitable test equipment shall be utilized to ensure spurious oscillations are not being generated by the subject signal booster. This test shall be conducted at the time of installation and at subsequent annual inspections.
8. Systems incorporating Class B signal-booster devices or Class B broadband fiber remote devices shall be tested using two portable radios simultaneously conducting subjective voice quality checks. One portable radio shall be positioned not greater than 10 feet (3048 mm) from ~~the~~an indoor antenna. The second portable radio shall be positioned at a distance that represents the farthest distance from any indoor antenna. With both portable radios simultaneously keyed up on different frequencies within the same band, subjective audio testing shall be conducted and comply with DAQ levels as specified in Sections 510.4.1.1 and 510.4.1.2.

510.5.4 FCC compliance. The emergency ~~responder radio communication~~ coverage system installation and components shall comply with all applicable federal regulations including, but not limited to, FCC 47 CFR Part 90.219.

510.6 Maintenance. The emergency ~~responder radio communication~~ coverage system shall be maintained operational at all times in accordance with Sections 510.6.1 through 510.6.4.

510.6.1 Testing and proof of compliance. The owner of the building or owner's authorized agent shall have the emergency ~~responder radio communication~~ coverage system shall be inspected and tested annually or where structural changes occur including additions or remodels that could materially change the original field performance tests. Testing shall consist of the following:

1. In-building coverage test as described in Section 510.5.3.
2. Signal boosters shall be tested to verify that the gain is the same as it was upon initial installation and acceptance or set to optimize the performance of the system.
3. Backup batteries and power supplies shall be tested under load of a period of 1 hour to verify that they will properly operate during an actual power outage. If within the 1-hour test period the battery exhibits symptoms of failure, the test shall be extended for additional 1-hour periods until the integrity of the battery can be determined.
4. ~~Other~~All active components shall be checked to verify operation within the manufacturer's specifications. ~~5.~~

At the conclusion of the testing, a report, which shall verify compliance with Section 510.5.3, shall be submitted to the *fire code official*.

510.6.2 Additional frequencies. The building *owner* shall modify or expand the emergency ~~responder radio communication~~ coverage system at his or her expense in the event frequency changes are required by the FCC or

other radio licensing authority, or additional frequencies are made available by the FCC or other radio licensing authority. Prior approval of a ~~public safety radio~~ an emergency communication coverage system on previous frequencies does not exempt this section.

510.6.3 Nonpublic safety system. Where other nonpublic safety amplification systems installed in buildings reduce the performance or cause interference with the emergency ~~responder communications~~ communication coverage system, the nonpublic safety amplification system shall be corrected or removed.

[A] 105.7.6 Emergency ~~responder radio~~ communication coverage system. A construction permit is required for installation of or modification to emergency ~~responder radio~~ communication coverage systems and related equipment. Maintenance performed in accordance with this code is not considered to be a modification and does not require a construction permit.

907.2.12.2 Fire department communication system. Where a wired communication system is *approved* in lieu of an emergency ~~responder radio~~ communication coverage system in accordance with Section 510, the wired fire department communication system shall be designed and installed in accordance with NFPA 72 and shall operate between a *fire command center* complying with Section 508, elevators, elevator lobbies, emergency and standby power rooms, fire pump rooms, areas of refuge and inside *interior exit stairways*. The fire department communication device shall be provided at each floor level within the *interior exit stairway*.

914.3.6 Emergency ~~responder radio~~ communication coverage. Emergency ~~responder radio~~ communication coverage shall be provided in accordance with Section 510.

1103.2 Emergency ~~responder radio~~ communication coverage in existing buildings. Existing buildings other than Group R-3, that do not have approved ~~radio~~ communication coverage for emergency responders in the building based on existing coverage levels of the public safety communication systems, shall be equipped with such coverage according to one of the following:

1. Where an existing wired communication system cannot be repaired or is being replaced, or where not approved in accordance with Section 510.1, Exception 1.
2. Within a time frame established by the adopting authority.

Exception: Where it is determined by the fire code official that the ~~radio~~ emergency communication coverage system is not needed.

1203.2.3 Emergency ~~responder radio~~ communication coverage systems. Standby power shall be provided for emergency ~~responder radio~~ communication coverage systems as required in Section 510.4.2.3. The standby power supply shall be capable of operating the emergency ~~responder radio~~ communication coverage system for a duration of not less than 24 hours.

2018 International Building Code

Revise as follows:

[F] 403.4.5 Emergency ~~responder radio~~ communication coverage. Emergency ~~responder radio~~ communication coverage shall be provided in accordance with Section 510 of the International Fire Code.

[F] 907.2.12.2 Fire department communication system. Where a wired communication system is *approved* in lieu of an emergency ~~responder radio~~ communication coverage system in accordance with Section 510 of the International Fire Code, the wired fire department communication system shall be designed and installed in accordance with NFPA 72 and shall operate between a fire command center complying with Section 911, elevators, elevator lobbies, emergency and standby power rooms, fire pump rooms, *areas of refuge* and inside *interior exit stairways*. The fire department communication device shall be provided at each floor level within the *interior exit stairway*.

SECTION 918 EMERGENCY RESPONDER RADIO COMMUNICATION COVERAGE

[F] 918.1 General. Emergency ~~responder radio~~ communication coverage shall be provided in all new buildings in accordance with Section 510 of the International Fire Code.

[F] 2702.2.3 Emergency ~~responder radio~~ communication coverage systems. Standby power shall be provided for emergency ~~responder radio~~ communication coverage systems required in Section 918 and the International Fire Code. The standby power supply shall be capable of operating the emergency ~~responder radio~~ communication coverage system for a duration of not less than 24 hours.

communication coverage system for a duration of not less than 12 hours at 100-percent system operation capacity.

Reason:

This proposal is editorial in nature. Section 510 in the 2018 IFC uses several different terms to describe the communication system required. It could be:

1. Emergency responder radio coverage system - Section 510.1
2. Emergency responder communication enhancement - Section 510.4.1
3. Emergency communications enhancement system - Section 510.4.1
4. Public safety communications enhancement system - Section 510.4.2.1
5. Radio enhancement system - Section 510.4.2.8
6. Public safety radio coverage system - Section 510.5

This proposal replaces all of these various terms with "emergency communication coverage system".

This will eliminate confusion and provide consistency in understanding the requirements which will improve consistent application of the requirements.

Other minor editorial revisions occur in Section 510.4.2.4 Item 6, Section 510.5.3 Item 8 and Section 510.4.6.1 Item 4.

References to the emergency communication system requirements are correlated in other sections of the IFC and IBC.

Cost Impact

The code change proposal will not increase or decrease the cost of construction .

This is editorial and will not change application of the requirements.

Internal ID: 2107

F46-18

IFC: 202 (New), 510.1, 510.1.1 (New), 510.2 (New), 510.2.2 (New), 510.2.3 (New), 510.2.4 (New), 510.2.5 (New), 510.4.1.1, 510.4.1.2, 510.4.1.3, 510.4.2.2, 510.5.1, 510.5.2, 510.5.4, 510.6.4, 1103.2

Proponent: Mark Chubb, Telgian Corp., representing Telgian Corp. (mchubb@telgian.com)

2018 International Fire Code

Add new definition as follows:

FIRE SERVICE ACCESS POINT.

A location inside or outside a building that is protected from conditions considered immediately dangerous to life and health from which firefighters have access to a reliable water supply for firefighting and other resources necessary to engage in firefighting or rescue operations. Such locations outside a building include a place not less than 100 sq ft in area and not less than 10-ft nor more than 30-ft from an exterior door opening that is adjacent to a fire apparatus access road. Such locations inside buildings include stairway landings in smokeproof enclosures located one level below a fire-involved floor and areas of refuge equipped with standpipe outlets.

CHAPTER 5 FIRE SERVICE FEATURES

510 EMERGENCY RESPONDER RADIO COVERAGE

510.1 Where required. Emergency responder radio coverage systems shall be installed in new and existing buildings where required by this section.

Add new text as follows:

510.1.1 New buildings. Emergency responder radio coverage systems satisfying the technical criteria specified in 510.4.1 shall be provided in all new high-rise buildings, buildings in which portions of the floor area are located more than 250-ft from the nearest fire service access point measured along the normal route of travel, and buildings in which areas of refuge are provided for occupants that require a defend-in-place strategy or rescue assistance due to age, infirmity, involuntary confinement or supervision.

Revise as follows:

~~**510.2 510.1.2 Emergency responder radio coverage in existing Existing buildings.** Existing high-rise buildings and underground buildings in which any portion of the floor area is located more than 250-ft from the nearest fire service access point when measured along the normal route of travel shall be provided with approved radio coverage for emergency responders as required in Chapter 11.~~

Add new text as follows:

510.2 Where not required. Emergency responder radio coverage systems are not required in the buildings or circumstances listed in this section and where determined by the fire code official that such systems are not needed.

Revise as follows:

~~**510.1 510.2.1 Emergency responder radio coverage in new buildings. Two-way firefighter communication systems.**~~

~~New buildings shall have approved radio coverage for emergency responders within the building based on the existing coverage levels of the public safety communication systems utilized by the jurisdiction, measured at the exterior of the building. This section shall not require improvement of the existing public safety communication systems.~~

Exceptions:

- ~~1. Where approved by the building official and the fire code official, a wired communication system in accordance with Section 907.2.12.2 shall be permitted to be installed or maintained instead of an approved radio coverage system.~~
- ~~2. Where it is determined by the fire code official that the radio coverage system is not needed.~~
- ~~3. In facilities where emergency responder radio coverage is required and such systems, components or equipment required could have a negative impact on the normal operations of that facility, the fire code official shall have the authority to accept an automatically activated~~

emergency responder radio coverage system.

Add new text as follows:

510.2.2 Inadequate public safety radio network coverage. Where the existing public safety radio network provides incomplete, inconsistent or inadequate radio coverage outside a building, the building owner shall not be required to install an emergency responder radio coverage system or invest in other improvements to the public safety communication system. For purposes of this section, a transmitted or received signal strength of less than -75 dBm to and from the nearest fixed transmitter or repeater and a handheld portable radio located at a point outside the building consistent with the location of an incident command post shall constitute inadequate radio system coverage. In addition, an adequate signal shall provide a Delivered Audio Quality (DAQ) of 3.0 or an equivalent Signal-to-Interference-plus-Noise-Ratio (SINR) applicable to the technology for either analog or digital signals.

510.2.3 Cellular voice and data service access not required. This section does not require building owners to provide access to cellular telephone or mobile data services to public safety agencies or the general public, including services on Band 14 of the Evolved Universal Mobile Telecommunications System Terrestrial Radio Access (E-UTRA or LTE) spectrum.

510.2.4 Alternative means of compliance. Where fixed or mobile repeaters operated and maintained by the responding public safety agencies are provided or added to improve mobile and portable radio coverage.

510.2.5 Unacceptable interference. In facilities where emergency responder radio coverage is required and such systems, components or equipment could have a negative impact on the normal operations of that facility, the fire code official shall have the authority to accept an automatically activated emergency responder radio coverage system.

510.3 Permit required. A construction permit for the installation of or modification to emergency responder radio coverage systems and related equipment is required as specified in Section 105.7.6. Maintenance performed in accordance with this code is not considered a modification and does not require a permit.

510.4 Technical requirements. Systems, components and equipment required to provide the emergency responder radio coverage system shall comply with Sections 510.4.1 through 510.4.2.8.

510.4.1 Emergency responder communication enhancement system signal strength. The building shall be considered to have acceptable emergency responder communications enhancement system coverage when signal strength measurements in 95 percent of all areas on each floor of the building meet the signal strength requirements in Sections 510.4.1.1 through 510.4.1.3.

Revise as follows:

510.4.1.1 Minimum signal strength into the building. ~~The minimum inbound signal strength shall be sufficient to provide usable voice communications throughout the coverage area as specified by the fire code official, measured from a point outside the building consistent with the location of an incident command post using a portable transmitter operating in simplex mode having a power output not greater than that of a handheld radio of the type used by the public safety agency to points inside the building consistent with the method described in Section 510.5.3.~~ The inbound signal level shall be sufficient to provide not less than a Delivered Audio Quality (DAQ) of 3.0 or an equivalent Signal-to-Interference-Plus-Noise Ratio (SINR) applicable to the technology for either analog or digital signals.

510.4.1.2 Minimum signal strength out of the building. ~~The minimum outbound signal strength shall be sufficient to provide usable voice communications throughout the coverage area as specified by the fire code official, measured from points inside the building as specified in Section 510.5.3 to a point outside the building consistent with the location of an incident command post using a portable transmitter operating in simplex mode having a power output not greater than that of a handheld radio of the type used by the public safety agency.~~ The outbound signal level shall be sufficient to provide not less than a DAQ of 3.0 or an equivalent SINR applicable to the technology for either analog or digital signals.

Delete without substitution:

~~**510.4.1.3 System performance.** Signal strength shall be sufficient to meet the audibility and intelligibility requirements of the applications being utilized by public safety for emergency operations through the coverage area as specified by the fire code official in Section 510.4.2.2.~~

510.4.2 System design. The emergency responder radio coverage system shall be designed in accordance with Sections 510.4.2.1 through 510.4.2.8 and NFPA 1221.

510.4.2.1 Amplification systems and components. Buildings and structures that cannot support the required level of radio coverage shall be equipped with systems and components to enhance the public safety radio signals and achieve the required level of radio coverage specified in Sections 510.4.1 through 510.4.1.3. Public safety communications enhancement systems utilizing radio-frequency-emitting devices and cabling shall be approved by the *fire code official*. Prior to installation, all RF-emitting devices shall have the certification of the radio licensing authority and be suitable for public safety use.

Revise as follows:

510.4.2.2 Technical criteria. The *fire code official* shall maintain a document providing the specific technical information and requirements for the emergency responder communications coverage system. This document shall contain, but not be limited to, the various frequencies required, the location of radio sites, the effective radiated power of radio sites, the maximum propagation delay in microseconds, the ~~applications-modes being used, incident-ground communication practices, including accountability, situation reporting, and mayday procedures, as well as other~~ supporting technical information necessary for system design.

510.4.2.3 Standby power. Emergency responder radio coverage systems shall be provided with dedicated standby batteries or provided with 2-hour standby batteries and connected to the facility generator power system in accordance with Section 1203. The standby power supply shall be capable of operating the emergency responder radio coverage system at 100-percent system capacity for a duration of not less than 12 hours.

510.4.2.4 Signal booster requirements. If used, signal boosters shall meet the following requirements:

1. All signal booster components shall be contained in a National Electrical Manufacturer's Association (NEMA) 4-type waterproof cabinet.
2. Battery systems used for the emergency power source shall be contained in a NEMA 3R or higher-rated cabinet.
3. Equipment shall have FCC or other radio licensing authority certification and be suitable for public safety use prior to installation.
4. Where a donor antenna exists, isolation shall be maintained between the donor antenna and all inside antennas to not less than 20dB greater than the system gain under all operating conditions.
5. Bi-Directional Amplifiers (BDAs) used in emergency responder radio coverage systems shall have oscillation prevention circuitry.
6. The installation of amplification systems or systems that operate on or provide the means to cause interference on any emergency responder radio coverage networks shall be coordinated and approved by the *fire code official*.

510.4.2.5 System monitoring. The emergency responder radio enhancement system shall be monitored by a listed *fire alarm control unit*, or where approved by the *fire code official*, shall sound an audible signal at a constantly attended on-site location. Automatic supervisory signals shall include the following:

1. Loss of normal AC power supply.
2. System battery charger(s) failure.
3. Malfunction of the donor antenna(s).
4. Failure of active RF-emitting device(s).
5. Low-battery capacity at 70-percent reduction of operating capacity.
6. Failure of critical system components.
7. The communications link between the *fire alarm system* and the emergency responder radio enhancement system.

510.4.2.6 Additional frequencies and change of frequencies. The emergency responder radio coverage system shall be capable of modification or expansion in the event frequency changes are required by the FCC or other radio licensing authority, or additional frequencies are made available by the FCC or other radio licensing authority.

510.4.2.7 Design documents. The *fire code official* shall have the authority to require "as-built" design documents

and specifications for emergency responder communications coverage systems. The documents shall be in a format acceptable to the *fire code official*.

510.4.2.8 Radio communication antenna density. Systems shall be engineered to minimize the near-far effect. Radio enhancement system designs shall include sufficient antenna density to address reduced gain conditions.

Exceptions:

1. Class A narrow band signal booster devices with independent AGC/ALC circuits per channel.
2. Systems where all portable devices within the same band use active power control features.

510.5 Installation requirements. The installation of the public safety radio coverage system shall be in accordance with NFPA 1221 and Sections 510.5.1 through 510.5.4.

510.5.1 Approval prior to installation. Amplification systems capable of operating on frequencies licensed to any public safety agency by the FCC or other radio licensing authority shall not be installed without prior coordination and approval of the ~~fire code official~~licensee.

510.5.2 Minimum qualifications of personnel. The ~~minimum qualifications of the system designer and lead installation personnel shall include both of the following:~~

- ~~1. A valid FCC issued general radio operators license.~~
- ~~2. Certification of in building system training issued by an approved organization or approved school, or a certificate issued by the manufacturer of the equipment being installed.~~

~~These qualifications shall not be required where demonstration of adequate skills and experience satisfactory to the fire code official is provided.~~ possess valid Type PG General Radiotelephone Operator licenses issued by the FCC.

510.5.3 Acceptance test procedure. Where an emergency responder radio coverage system is required, and upon completion of installation, the building *owner* shall have the radio system tested to verify that two-way coverage on each floor of the building is not less than 95 percent. The test procedure shall be conducted as follows:

1. Each floor of the building shall be divided into a grid of 20 approximately equal test areas.
2. The test shall be conducted using a calibrated portable radio of the latest brand and model used by the agency talking through the agency's radio communications system or equipment approved by the fire code official.
3. Failure of more than one test area shall result in failure of the test.
4. In the event that two of the test areas fail the test, in order to be more statistically accurate, the floor shall be permitted to be divided into 40 equal test areas. Failure of not more than two nonadjacent test areas shall not result in failure of the test. If the system fails the 40-area test, the system shall be altered to meet the 95-percent coverage requirement.
5. A test location approximately in the center of each test area shall be selected for the test, with the radio enabled to verify two-way communications to and from the outside of the building through the public agency's radio communications system. Once the test location has been selected, that location shall represent the entire test area. Failure in the selected test location shall be considered to be a failure of that test area. Additional test locations shall not be permitted.
6. The gain values of all amplifiers shall be measured and the test measurement results shall be kept on file with the building *owner* so that the measurements can be verified during annual tests. In the event that the measurement results become lost, the building *owner* shall be required to rerun the acceptance test to reestablish the gain values.
7. As part of the installation, a spectrum analyzer or other suitable test equipment shall be utilized to ensure spurious oscillations are not being generated by the subject signal booster. This test shall be conducted at the time of installation and at subsequent annual inspections.
8. Systems incorporating Class B signal-booster devices or Class B broadband fiber remote devices shall be tested using two portable radios simultaneously conducting subjective voice quality checks. One portable radio shall be positioned not greater than 10 feet (3048 mm) from the indoor antenna. The second portable radio shall be positioned at a distance that represents the farthest distance from any indoor antenna. With both portable radios simultaneously keyed up on different frequencies within the same band, subjective audio testing shall be conducted and comply with DAQ levels as specified in Sections 510.4.1.1 and 510.4.1.2.

510.5.4 FCC compliance. The emergency responder radio coverage system installation and components shall comply with all applicable federal regulations, including, but not limited to, FCC 47 CFR Part 90.219.

510.6 Maintenance. The emergency responder radio coverage system shall be maintained operational at all times in accordance with Sections 510.6.1 through 510.6.4.

510.6.1 Testing and proof of compliance. The owner of the building or owner's authorized agent shall have the emergency responder radio coverage system shall be inspected and tested annually or where structural changes occur including additions or remodels that could materially change the original field performance tests. Testing shall consist of the following:

1. In-building coverage test as described in Section 510.5.3.
2. Signal boosters shall be tested to verify that the gain is the same as it was upon initial installation and acceptance or set to optimize the performance of the system.
3. Backup batteries and power supplies shall be tested under load of a period of 1 hour to verify that they will properly operate during an actual power outage. If within the 1-hour test period the battery exhibits symptoms of failure, the test shall be extended for additional 1-hour periods until the integrity of the battery can be determined.
4. Other active components shall be checked to verify operation within the manufacturer's specifications.
5. At the conclusion of the testing, a report, which shall verify compliance with Section 510.5.3, shall be submitted to the *fire code official*.

510.6.2 Additional frequencies. The building owner shall modify or expand the emergency responder radio coverage system at his or her expense in the event frequency changes are required by the FCC or other radio licensing authority, or additional frequencies are made available by the FCC or other radio licensing authority. Prior approval of a public safety radio coverage system on previous frequencies does not exempt this section.

510.6.3 Nonpublic safety system. Where other nonpublic safety amplification systems installed in buildings reduce the performance or cause interference with the emergency responder communications coverage system, the nonpublic safety amplification system shall be corrected or removed.

Delete without substitution:

~~**510.6.4 Field testing.** Agency personnel shall have the right to enter onto the property at any reasonable time to conduct field testing to verify the required level of radio coverage.~~

Revise as follows:

1103.2 Emergency responder radio coverage in existing buildings. Existing high-rise buildings, underground buildings, institutional buildings in which all or part of the occupant load requires a defined-in-place strategy, and buildings in which any portion of the floor area is located more than 250-ft from the nearest fire service access opening when measured along the normal route of travel. Existing high-rise buildings and buildings other than Group R-3 that do not have approved radio coverage for emergency responders in the building based on existing coverage levels of the public safety communication systems, shall be equipped with such coverage according to one of the following:

1. Where an existing wired communication system cannot be repaired or is being replaced, or where not approved in accordance with Section 510.1, Exception 1.
2. Within a time frame established by the adopting authority.

Exception: Where it is determined by the fire code official that the radio coverage system is not needed.

Reason:

The scope of existing requirements to install emergency responder radio coverage systems in new buildings introduces an unacceptable degree of uncertainty in the design and construction process. Radio signal propagation in proposed buildings cannot be predicted accurately due to uncertainties regarding the influence of construction, building contents, and operating features [8]. As such, tests to determine whether radio coverage meets jurisdictional requirements must occur late in the construction process, often days before completion and intended occupancy. Failure to achieve the coverage requirements specified in Section 510 can result in unexpected additional costs of tens to hundreds of thousands of dollars at the very end of a construction program [1,7].

Many, if not most, fire and emergency services agencies report routine difficulties communicating from handheld portable radios inside buildings. In many, if not most of the instances in which such problems occur, operators are attempting to transmit signals to fixed repeaters that rebroadcast their messages to other users on the public safety radio network. Although such difficulties are unfortunate and may be distressing to public safety users, they are also inconsistent with the design of most public safety radio systems. Very few public radio systems are designed, specified, installed, operated, and maintained to ensure consistent coverage inside buildings.

Reliance on the use of handheld radios by firefighters has expanded considerably in recent years, often with little or no regard to the added demands such users place on the radio systems hosting these transceivers. The reliance on handheld radios operating in multiplex mode through remote repeaters is not recommended as a primary much less sole means of ensuring fireground communications and accountability for firefighters operating in immediately dangerous to life and health environments. The use of simplex communication between incident commanders and firefighters operating inside buildings provides greater reliability.

The introduction of Section 510 requirements in 2009 recognized the inherent dangers faced by firefighters operating in high-rise buildings and similarly complex structures. In the past, the code required two-way firefighters' phone systems in such premises. In many, if not most cases, improved radio coverage provides a more reliable and cost-effective approach to ensuring firefighter communication and safety in such circumstances.

As currently presented, Section 510's requirements apply to a wide range of buildings not previously considered candidates for firefighter communication systems. As such, the requirements have come to be applied to situations in which reliable firefighter communications seems to be more of an end itself than a means to other ends.

Although software for modeling radio propagation does exist, it does not yield reliable results when attempting to predict public safety radio system coverage inside buildings. These programs do provide a means of designing such systems efficiently and reliably when it is clear that they are required.

Clearly, firefighters require reliable and efficient means of communication in buildings where they must operate for extended periods of time in locations remote from support resources and rapid-intervention teams, where they must support the protection, relocation, or evacuation of defend-in-place occupants, or where escape or evacuation during firefighting is unusually difficult, confusing, or time-consuming.

The proposed change introduces greater certainty into the application of these requirements by specifying building heights and travel distances related to firefighter access and safety. New exclusions clarify the intent by ensuring not only that the requirements are not applied to require the jurisdiction to improve public safety radio coverage outside new buildings, but also ensures that building owners do not bear undue cost burdens to correct deficiencies in the design, operation or maintenance of existing public safety radio systems. A new section recognizing alternative means of compliance through fixed or mobile repeaters is added to afford fire code officials, public safety agencies, and owners of large building complexes or campuses an opportunity to negotiate cost-effective remedies to providing enhanced radio coverage in multiple similarly situated buildings.

Provisions clarifying performance and test parameters are added to recognize that portable handheld radios do not provide reliable means of transmitting signals to public safety network repeaters in many, if not most, circumstances. Best-practice incident ground operating procedures employ simplex communication between firefighters and rescuers entering environments immediately dangerous to life and health and those outside the environment responsible for their safety, extrication, or rescue under exigent circumstances.

Reports from the investigation of firefighter line-of-duty deaths indicate communication failures contribute to but do not cause most serious injuries and deaths, and rarely if ever involve propagation failures. The most common communication failures reported in firefighter casualty investigations involve

1. Not reporting situations of difficulty or distress,
2. Not conveying conditions, actions, and intentions,
3. Inaccurately or incorrectly reporting positions or locations,
4. Missing critical messages due to distractions or interference (in the recipient's environment), and
5. Incorrect operation of equipment, such as using the wrong channel or talkgroup.

No firefighter line of duty death has been reported in a fully-sprinklered building.[3]

In addition to rescoping the provisions to improve certainty of application and intentions related to firefighter and rescuer operations, the proposed change also limits the application of these requirements to radiotelephone communication systems by clearly and unambiguously stating that the provisions do not require improvements to facilitate cellular voice and data service access, including Band 14 of the E-UTRA/LTE spectrum. This band has been designated for public safety broadband data services, which do not include emergency voice communications [5]. (No current or proposed public safety devices or applications that use broadband service have been identified that directly facilitate emergency responder safety while operating in an environment considered immediately dangerous to

life and health [6]. Radio-over-IP [RoIP] and push-to-talk [PTT] applications are not currently recognized or accepted for use in high-risk environments.)

Requirements for designers and installers of emergency responder radio coverage systems beyond those specified by the Federal Communications Commission are deleted in accordance with the pre-emption doctrine [10].

Likewise, the authority of the fire code official to authorize installations and operation on specific frequencies is amended to conform to federal regulations requiring the explicit authorization of licensees to operate in-building radio systems on existing public safety frequencies [11]. (It should be noted that the fire code official may or may not be employed by the same jurisdiction or agency licensed to operate radios and repeaters on public safety radio frequencies installed.)

Right of entry is already afforded by the administrative provisions of the code, and reiteration of that authority here is unnecessary. Language in the section authorizing agency personnel to conduct field testing to verify the required level of radio coverage suggest these personnel possess the equipment and experience necessary to perform such tests, which is rarely the case. Even in those rare instances where personnel possess such qualifications and equipment, the authority to conduct tests is already afforded by the administrative provisions of the code.

In summary, the proposed changes recognize the primary responsibility for firefighter safety and health during emergency response operations rests on emergency services. Reliable communication is but one means of ensuring firefighter safety during firefighting and rescue operations. Effective communication under such circumstances requires much more than a reliable communication path. It also requires carefully-written and well-practiced procedures for operating in environments considered immediately dangerous to life and health, which includes incident-ground communication procedures and robust equipment maintenance.

Bibliography:

[1] "Bi-Directional Amplifiers (BDA) vs. Distributed Antenna Systems (DAS)." SignalBooster.com, Sept. 18, 2017. <https://www.signalboosters.com/blog/news/bi-directional-amplifiers-bda-vs-das-distributed-antenna-systems>.

[2] "Do police and firefighters die young?" Encore Blog, MarketWatch, July 31, 2014. <https://blogs.marketwatch.com/encore/2014/07/31/do-police-and-firefighters-die-young/>.

[3] Firefighter Fatalities in the United States - 2016. National Fire Protection Association, June 2017. <http://www.nfpa.org/-/media/Files/News-and-Research/Fire-statistics/Fire-service/osFFF.pdf>[5] Firefighter Fatalities in the United States - 2016. National Fire Protection Association, June 2017. <http://www.nfpa.org/-/media/Files/News-and-Research/Fire-statistics/Fire-service/osFFF.pdf>

[4] Fire Fighter Fatality Investigation and Prevention. National Institute of Occupational Safety and Health, U.S. Centers for Disease Control and Prevention, 2017. <https://www.cdc.gov/niosh/fire.default.html>.

[5] FirstNet and Fire Services. First Responder Network Authority, 2017. <https://www.firstnet.gov/resources/firstnet-and-fire-services>.

[6] FirstNet Fire Fact Sheet. First Responder Network Authority, June 2, 2017. <https://www.firstnet.gov/sites/default/files/FirstNet-Fire-Factsheet-06-02-2017.pdf>.

[7] "How much does a DAS system cost?" Day Wireless Blog, Sep. 11, 2015. <https://www.daywireless.com/blog/index.php/2017/09/11/how-much-does-a-das-cost/>.

[8] Indoor radio propagation. Spread Spectrum Scene, Jan. 6. 2001. <https://www.sss-mag.com/indoor.html>.

[9] Occupational Employment and Wages, 33-2011 Firefighters. Bureau of Labor Statistics, U.S. Department of Labor, May 2016. <https://www.bls.org/oes/current/oes332011.htm>.

[10] The Supremacy Clause and the Doctrine of Preemption. FindLaw. <https://litigation.findlaw.com/legal-system/the-supremacy-clause-and-the-doctrine-of-preemption.html?version=2>.

[11] Use of signal boosters, 47 CFR 90.219. Federal Communications Commission. U.S. Government Printing Office. <https://www.gpo.gov/fdsys/granule/CFR-2010-title47-vol5/CFR-2010-title47-vol5-sec90-219>.

[12] USFA Publications. U.S. Fire Administration, Federal Emergency Management Agency, Department of Homeland Security, 2017. <https://apps.usfa.fema.gov/publications/>.

[13] Volunteer Fire Service Fact Sheet, National Volunteer Fire Council. 2017. <https://www.nvfc.org/wp-content/uploads/2016/02/NVFC-Fact-Sheet-2017.pdf>

Cost Impact

The code change proposal will decrease the cost of construction .

The unnecessary or inappropriate application of emergency responder radio coverage system requirements to new and existing buildings adds tens to hundreds of thousands of dollars in costs to construction of individual buildings. Benefits from reducing preventable injuries or deaths to emergency responders can save hundreds of thousands to millions of dollars.

A single firefighter line-of-duty results in direct and indirect costs to the public to pay death benefits; hire, train and equip [13] a replacement firefighter; and conduct a thorough investigation into the circumstances surrounding the incident. These costs could be estimated as follows:

1. Death benefits paid to survivor(s): \$2.6 million (based on annual compensation at median firefighter salary [9] adjusted for inflation over 35-year life expectancy [2] beyond median firefighter age at time of death [3])
2. Succession costs: \$250,000
3. Investigation costs: \$150,000

Experienced installers of bi-directional amplifiers and distributed antenna systems (BDA/DAS) for emergency responder radio coverage systems estimate costs varying between \$0.50 to \$5.00 per square foot of occupied floor area depending upon construction type, building configuration, and power output [1,7]. At a median cost per square foot of floor area of \$2.75 per square foot, a floor area of approximately 11,000,000 sq ft could be protected. This is comparable to approximately 10 new single-story supermarkets or retail stores of the typical footprint.

Emergency responder injuries and deaths in such occupancies are exceedingly rare events. In a typical year, less than five firefighter line-of-duty deaths occur during interior operations in occupancies other than one or two family dwellings [3]. Studies of such incidents by the National Institutes of Occupational Safety and Health [4] and the U.S. Fire Administration major fires investigation program [12] do not suggest communication failures due to signal propagation are a proximate cause of these deaths.

Communication failures contributing to serious injuries and deaths during firefighting operations typically involve failure to develop, implement, and adhere to standard operating practices governing operations in conditions immediately dangerous to life and health.

The rate of serious injuries is not known, but could be conservatively estimated not to exceed 25 serious injuries requiring hospitalization and lost work time per reported death.

At these rates, the existing requirements have a significant negative benefit-to-cost ratio. The proposed code change reduces but does not eliminate the negative benefit-to-cost ratio related to the application of these requirements to new and existing buildings.

Based on this analysis, the deployment of mobile public safety repeaters to incidents by fire and emergency services would be a far more economical and efficient method of ensuring reliable communication in many if not most situations.

Internal ID: 139

F47-18

IFC: 510.1.1 (New), 510.1.1.1 (New)

Proponent: Adria Reinertson, Riverside County Fire Department, representing Riverside County Fire Department, California Fire Chiefs Association (adriar@moval.org)

2018 International Fire Code

Add new text as follows:

510.1.1 Building conduit and pathway survivability. All new buildings shall be constructed with not less than a two-inch (2") dedicated conduit raceway or other method approved by the fire code official for future expandability, or the installation of an Emergency Responder Radio Coverage System. The raceway shall meet pathway survivability requirements in NFPA 1221 and shall be installed from the lowest floor level to the roof.

510.1.1.1 Identification. The raceway and junction boxes shall be labeled "Emergency Responder Radio Coverage System use only".

Reason:

Communications are key to a successful response to an emergency incident. When emergency responder radio coverage systems are installed in a new building they are tested and approved for the conditions present at the time. Often times, as additional buildings and infrastructure are built in the immediate and adjacent vicinity, the original radio coverage system will no longer function as approved due to interference, etc. This proposal requires a dedicated raceway to be installed at time of construction to allow for future expandability and/ or the installation of a radio coverage system. This proposal would allow for easy expansion and/or installations without the additional cost of invasive retrofits to the original system.

Cost Impact

The code change proposal will increase the cost of construction .

This code change will increase the cost of construction due the requirement to install conduit for future use, however, it will greatly reduce the cost of future installations and/or retrofits for expandability.

Internal ID: 982

F48-18

IFC: 510.4, 80

Proponent: Michael O'Brian, Chair, representing FCAC (FCAC@iccsafe.org)

2018 International Fire Code

Revise as follows:

510.4 Technical requirements. Equipment required to provide emergency responder radio coverage shall be listed in accordance with UL 2524. Systems, components and equipment required to provide the emergency responder radio coverage system shall comply with Sections 510.4.1 through 510.4.2.8.

Add new standard(s) follows:

UL

Underwriters Laboratories LLC
333 Pfingsten Road
Northbrook IL 60062

UL 2524 -2018:

Outline of Investigation for In-building 2-Way Emergency Radio Communication Enhancement Systems

Reason:

This is one of 10 proposals being submitted as a package relating to technical changes proposed for Section 510. While the Fire Code Committee will consider each proposal independently, the intent is for approval of all proposals in this package which have been submitted as a correlated set of companion code change proposals.

This proposal adds a requirement to test and list equipment installed to enhance emergency responder radio coverage in buildings to ensure fire and shock safety and compliance with the performance requirements specified in IFC Section 510 and NFPA 1221.

This proposal is submitted by the ICC Fire Code Action Committee (FCAC). The FCAC was established by the ICC Board of Directors to pursue opportunities to improve and enhance assigned International Codes with regard to fire safety and hazardous materials in new and existing buildings and facilities and the protection of life and property in wildland urban interface areas. In 2017 the Fire-CAC has held 3 open meetings. In addition, there were numerous conference calls, Regional Work Group and Task Group meetings for the current code development cycle, which included members of the committees as well as any interested parties, to discuss and debate the proposed changes. Related documentation and reports are posted on the FCAC website at: <https://www.iccsafe.org/codes-tech-support/cs/fire-code-action-committee-fcac/>

Cost Impact

The code change proposal will increase the cost of construction .

The requirement to test and list equipment will add to the cost for required equipment installed in new or existing buildings. The cost to test and certify safe equipment should not add more than 1/2% to the total cost of this equipment.

Internal ID: 377

F49-18

IFC: 202 (New), 510.4.1

Proponent: Michael O'Brian, Chair, representing FCAC (FCAC@iccsafe.org)

2018 International Fire Code

Add new definition as follows:

CRITICAL AREAS. Areas that are designated for emergency responder radio coverage including exit stairs, exit passageways, elevator lobbies, fire protection equipment room and control valve locations, fire command centers and other areas identified by the fire code official.

Revise as follows:

510.4.1 Emergency responder communication enhancement system signal strength. The building shall be considered to have acceptable emergency responder communications enhancement system coverage when signal strength measurements in 95 percent of all areas and 99 percent in critical areas on each floor of the building meet the signal strength requirements in Sections 510.4.1.1 through 510.4.1.3.

Reason:

This is one of 10 proposals being submitted as a package relating to technical changes proposed for Section 510. While the Fire Code Committee will consider each proposal independently, the intent is for approval of all proposals in this package which have been submitted as a correlated set of companion code change proposals.

This proposal is submitted by the ICC Fire Code Action Committee (FCAC). The FCAC was established by the ICC Board of Directors to pursue opportunities to improve and enhance assigned International Codes with regard to fire safety and hazardous materials in new and existing buildings and facilities and the protection of life and property in wildland urban interface areas. In 2017 the Fire-CAC has held 3 open meetings. In addition, there were numerous conference calls, Regional Work Group and Task Group meetings for the current code development cycle, which included members of the committees as well as any interested parties, to discuss and debate the proposed changes. Related documentation and reports are posted on the FCAC website at: <https://www.iccsafe.org/codes-tech-support/cs/fire-code-action-committee-fcac/>

This proposal clarifies existing requirements within the 2018 edition of Section 510 through a reference to NFPA 1221 by placing the language related to 99% in critical areas within the technical provisions of 510.4.1. Covering critical areas of a building is vital to the operations of public safety responders. A definition for "critical areas" has been included to clarify what is intended by that term. As the definition notes critical areas include such areas as exit stairways, elevator lobbies, fire pump rooms, etc.

Cost Impact

The code change proposal will not increase or decrease the cost of construction .

This is already required in NFPA 1221. Section 510.4.2 requires compliance with NFPA 1221.

Internal ID: 967

F50-18

IFC: 510.4.1.1

Proponent: Michael O'Brian, Chair, representing FCAC (fcac@iccsafe.org)

2018 International Fire Code

Revise as follows:

510.4.1.1 Minimum signal strength into the building. The minimum inbound signal strength shall be sufficient to provide usable voice communications throughout the coverage area as specified by the *fire code official*. The inbound signal level shall be a minimum of -95dBm throughout the coverage area and sufficient to provide not less than a Delivered Audio Quality (DAQ) of 3.0 or an equivalent Signal-to-Interference-Plus-Noise Ratio (SINR) applicable to the technology for either analog or digital signals.

Reason:

This is one of 10 proposals being submitted as a package relating to technical changes proposed for Section 510. While the Fire Code Committee will consider each proposal independently, the intent is for approval of all proposals in this package which have been submitted as a correlated set of companion code change proposals.

This proposal is submitted by the ICC Fire Code Action Committee (FCAC). The FCAC was established by the ICC Board of Directors to pursue opportunities to improve and enhance assigned International Codes with regard to fire safety and hazardous materials in new and existing buildings and facilities and the protection of life and property in wildland urban interface areas. In 2017 the Fire-CAC has held 3 open meetings. In addition, there were numerous conference calls, Regional Work Group and Task Group meetings for the current code development cycle, which included members of the committees as well as any interested parties, to discuss and debate the proposed changes. Related documentation and reports are posted on the FCAC website at: <https://www.iccsafe.org/codes-tech-support/cs/fire-code-action-committee-fcac/>

This proposal is intended to put the minimum design criteria of -95dBm back into the code for the inbound signal also know as the downlink and clarify it is intended to apply throughout the coverage area while at the same time providing a DAQ of 3.0. dBm is an abbreviation for the power ratio in decibels (dB) of the measured power referenced to one milliwatt (mW). It is used in radio, microwave and fiber-optical communication networks as a convenient measure of absolute power because of its capability to express both very large and very small values in a short form. Specifying the minimum design criteria for the downlink provides a benchmark for system designers to utilize when designing a system and the DAQ 3.0 provision provides testing criteria.

Cost Impact

The code change proposal will not increase or decrease the cost of construction .

Industry practice is to utilize a design parameter somewhere around -95dBm to determine if their design will work properly therefore this is simply a clarification..

Internal ID: 968

F51-18

IFC: 510.4.2.2

Proponent: Michael O'Brian, Chair, representing FCAC (fcac@iccsafe.org)

2018 International Fire Code

Revise as follows:

510.4.2.2 Technical criteria. The *fire code official* shall maintain a document available to approved system designers, providing the specific technical information and requirements for the emergency responder communications coverage system. This document shall contain, but not be limited to, the various frequencies required, the location of radio sites, the effective radiated power of radio sites, the maximum propagation delay in microseconds, the applications being used and other supporting technical information necessary for system design.

Reason:

This is one of 10 proposals being submitted as a package relating to technical changes proposed for Section 510. While the Fire Code Committee will consider each proposal independently, the intent is for approval of all proposals in this package which have been submitted as a correlated set of companion code change proposals.

This proposal is submitted by the ICC Fire Code Action Committee (FCAC). The FCAC was established by the ICC Board of Directors to pursue opportunities to improve and enhance assigned International Codes with regard to fire safety and hazardous materials in new and existing buildings and facilities and the protection of life and property in wildland urban interface areas. In 2017 the Fire-CAC has held 3 open meetings. In addition, there were numerous conference calls, Regional Work Group and Task Group meetings for the current code development cycle, which included members of the committees as well as any interested parties, to discuss and debate the proposed changes. Related documentation and reports are posted on the FCAC website at: <https://www.iccsafe.org/codes-tech-support/cs/fire-code-action-committee-fcac/>

This proposal is intended to clarify that the technical criteria listed within this code section shall be shared with industry in-building public safety communications system designers. Some code officials have expressed concern about sharing information related to their organizations public safety communications system with industry designers. However, without the information listed within this code section, a designer cannot properly design a system.

Cost Impact

The code change proposal will not increase or decrease the cost of construction .

The intention of this section is to provide this information to designers but this has not always been understood. This clarifies who this information needs to be provided to and that it needs to be made available. This is simply a clarification of that intent.

Internal ID: 970

F52-18

IFC: 510.4.2.4

Proponent: Michael O'Brian, Chair, representing FCAC (fcac@iccsafe.org)

2018 International Fire Code

Revise as follows:

510.4.2.4 Signal booster requirements. If used, signal boosters shall meet the following requirements:

1. All signal booster components shall be contained in a National Electrical Manufacturer's Association (NEMA) 4-type waterproof cabinet.
2. Battery systems used for the emergency power source shall be contained in a NEMA 3R or higher-rated cabinet.
3. Equipment shall have FCC or other radio licensing authority certification and be suitable for public safety use prior to installation.
4. Where a donor antenna exists, isolation shall be maintained between the donor antenna and all inside antennas to not less than 20dB greater than the system gain under all operating conditions.
5. ~~Bi-Directional Amplifiers (BDAs)~~ Active RF emitting devices used in emergency responder radio coverage systems shall have ~~oscillation prevention~~ built-in oscillation detection and control circuitry.
6. The installation of amplification systems or systems that operate on or provide the means to cause interference on any emergency responder radio coverage networks shall be coordinated and approved by the *fire code official*.

Reason:

This is one of 10 proposals being submitted as a package relating to technical changes proposed for Section 510. While the Fire Code Committee will consider each proposal independently, the intent is for approval of all proposals in this package which have been submitted as a correlated set of companion code change proposals.

This proposal is submitted by the ICC Fire Code Action Committee (FCAC). The FCAC was established by the ICC Board of Directors to pursue opportunities to improve and enhance assigned International Codes with regard to fire safety and hazardous materials in new and existing buildings and facilities and the protection of life and property in wildland urban interface areas. In 2017 the Fire-CAC has held 3 open meetings. In addition, there were numerous conference calls, Regional Work Group and Task Group meetings for the current code development cycle, which included members of the committees as well as any interested parties, to discuss and debate the proposed changes. Related documentation and reports are posted on the FCAC website at: <https://www.iccsafe.org/codes-tech-support/cs/fire-code-action-committee-fcac/>

This proposal is intended to clarify that only active RF emitting devices utilized in emergency responder radio coverage systems shall have circuitry built into their design that both detects and controls oscillation. When oscillation occurs it can create significant interference on public safety radio frequencies rendering them inoperable. Therefore, it is not sufficient to just detect oscillation is occurring but that the equipment have the capability to control it when it occurs by reducing the gain or shutting itself down also known as self-healing.

A separate code proposal for Section 510 being submitted will require that public safety in-building communications equipment be listed and tested to perform their intended function. Oscillation detection and control is a factor in that process. Additionally, the ability to detect and control oscillation is an industry best-practice by the majority of manufacturers.

Cost Impact

The code change proposal will not increase or decrease the cost of construction .

This proposal will not increase construction cost as the requirement was already within the code. This proposal clarifies that it applies to active RF emitting devices.

Internal ID: 971

F53-18

IFC: 510.4.2.5

Proponent: Michael O'Brian, Chair, representing FCAC (fcac@iccsafe.org)

2018 International Fire Code

Revise as follows:

510.4.2.5 System monitoring. The emergency responder radio enhancement system shall be monitored by a listed *fire alarm control unit*, or where approved by the *fire code official*, shall sound an audible signal at a constantly attended on-site location. Automatic supervisory signals shall include the following:

1. Loss of normal AC power supply.
2. System battery charger(s) failure.
3. Malfunction of the donor antenna(s).
4. Failure of active RF-emitting device(s).
5. Low-battery capacity at 70-percent reduction of operating capacity.
6. Failure of critical system components.
7. The communications link between the *fire alarm system* and the emergency responder radio enhancement system.
8. Oscillation of active RF-emitting device(s)

Reason:

This is one of 10 proposals being submitted as a package relating to technical changes proposed for Section 510. While the Fire Code Committee will consider each proposal independently, the intent is for approval of all proposals in this package which have been submitted as a correlated set of companion code change proposals.

This proposal is submitted by the ICC Fire Code Action Committee (FCAC). The FCAC was established by the ICC Board of Directors to pursue opportunities to improve and enhance assigned International Codes with regard to fire safety and hazardous materials in new and existing buildings and facilities and the protection of life and property in wildland urban interface areas. In 2017 the Fire-CAC has held 3 open meetings. In addition, there were numerous conference calls, Regional Work Group and Task Group meetings for the current code development cycle, which included members of the committees as well as any interested parties, to discuss and debate the proposed changes. Related documentation and reports are posted on the FCAC website at: <https://www.iccsafe.org/codes-tech-support/cs/fire-code-action-committee-fcac/>

IFC Section 510.4.2.4 requires that active RF emitting public safety in-building communications equipment detect and control oscillation because it can impact the public safety radio system operations. As such, public safety in-building communications systems should monitor when oscillation has or is occurring in order to provide detailed documentation of system stability and necessary data for system performance evaluation. Detailed data related to system performance is vital when troubleshooting system issues. Additionally, it can assist jurisdictions in identifying public safety radio system interference.

Cost Impact

The code change proposal will increase the cost of construction .

This proposal may increase the cost of construction if the building owner chooses equipment that does not already provide sufficient dry contacts for system monitoring. Many system components produced by industry have the ability to monitor the functions required by the code.

Internal ID: 973

F54-18

IFC: 510.4.2.8

Proponent: Michael O'Brian, Chair, representing FCAC (fcac@iccsafe.org)

2018 International Fire Code

Revise as follows:

510.4.2.8 Radio communication antenna density. Systems shall be engineered to minimize the near-far effect. Radio enhancement system designs shall include sufficient antenna density to address reduced gain conditions.

~~Exceptions-Exception:~~

- ~~1: Class A narrow band signal booster devices with independent AGC/ALC circuits per channel.~~
- ~~2: Systems where all portable devices within the same band use active power control features.~~

Reason:

This is one of 10 proposals being submitted as a package relating to technical changes proposed for Section 510. While the Fire Code Committee will consider each proposal independently, the intent is for approval of all proposals in this package which have been submitted as a correlated set of companion code change proposals.

This proposal is submitted by the ICC Fire Code Action Committee (FCAC). The FCAC was established by the ICC Board of Directors to pursue opportunities to improve and enhance assigned International Codes with regard to fire safety and hazardous materials in new and existing buildings and facilities and the protection of life and property in wildland urban interface areas. In 2017 the Fire-CAC has held 3 open meetings. In addition, there were numerous conference calls, Regional Work Group and Task Group meetings for the current code development cycle, which included members of the committees as well as any interested parties, to discuss and debate the proposed changes. Related documentation and reports are posted on the FCAC website at: <https://www.iccsafe.org/codes-tech-support/cs/fire-code-action-committee-fcac/>

Antenna density is critical to the design and functionality of public safety in-building communications systems. As Exception 1 is currently worded, some might perceive that if a Channelized Bi-Directional Amplifier (BDA) installed at the headend was feeding a fiber Distributed Antenna System (DAS) that they have met the intent of the code. While utilizing a Channelized BDA feeding a fiber DAS is not as bad as a Class B feeding a passive DAS, the fact is that near-far can still occur unless a fiber remote also has Class A capabilities. Near-far prohibits a second responder such as an EMS or fire crew working in another area of the structure communicating on a different talk group from being able to transmit on their radios thereby creating a life safety issue. Therefore, it is recommended that Exception 1 be deleted and require that system designers address near-far conditions regardless of equipment type.

Cost Impact

The code change proposal will not increase or decrease the cost of construction .

To properly design a public safety in-building communications system, antenna density must be considered because the potential for overdriving the uplink amplifiers is basically a given. Therefore, this code change proposal does not in and of itself increase construction cost.

Internal ID: 969

F55-18

IFC: 510.5, 510.5.1 (New)

Proponent: Michael O'Brian, Chair, representing FCAC (fcac@iccsafe.org)

2018 International Fire Code

Revise as follows:

510.5 Installation requirements. The installation of the public safety radio coverage system shall be in accordance with NFPA 1221 and Sections 510.5.1 through ~~510.5.4-510.5.5.~~

Add new text as follows:

510.5.1 Mounting of the donor antenna(s). To maintain proper alignment with the system designed donor site, donor antennas shall be permanently affixed on the building or where approved, mounted on a movable sled with a clearly visible sign stating "Movement or repositioning of this antenna is prohibited without approval from the fire code official". The antenna installation shall be in accordance with the applicable requirements in the International Building Code for weather protection of the building envelope.

Reason:

This is one of 10 proposals being submitted as a package relating to technical changes proposed for Section 510. While the Fire Code Committee will consider each proposal independently, the intent is for approval of all proposals in this package which have been submitted as a correlated set of companion code change proposals.

This proposal is submitted by the ICC Fire Code Action Committee (FCAC). The FCAC was established by the ICC Board of Directors to pursue opportunities to improve and enhance assigned International Codes with regard to fire safety and hazardous materials in new and existing buildings and facilities and the protection of life and property in wildland urban interface areas. In 2017 the Fire-CAC has held 3 open meetings. In addition, there were numerous conference calls, Regional Work Group and Task Group meetings for the current code development cycle, which included members of the committees as well as any interested parties, to discuss and debate the proposed changes. Related documentation and reports are posted on the FCAC website at: <https://www.iccsafe.org/codes-tech-support/cs/fire-code-action-committee-fcac/>

The location and direction the donor antenna is positioned is critical to the successful operation of a public safety in-building communications system. There are two basic methods of mounting donor antennas, either fixed or on an antenna sled held down by weights. Mounting the donor antenna in a fixed position limits the amount of movement that may occur. Although antenna sleds are common practice for mounting various types of antennas on a roof, for those utilized for public safety in-building communications systems they should be approved by the fire code official. Adding signage about the public safety use alerts others such as roofers, HVAC repair personnel to their importance and the need to make notification prior to moving them and rendering the public safety in-building communications system inoperable.

Cost Impact

The code change proposal will not increase or decrease the cost of construction .

This proposal does not add any new requirements to what is already required for the components of these systems. This proposal simply clarifies the location of installed donor antennas must be static to ensure system performance and reliability.

Internal ID: 975

F56-18

IFC: 510.5.3

Proponent: Michael O'Brian, Chair, representing FCAC (fcac@iccsafe.org)

2018 International Fire Code

Revise as follows:

510.5.3 Acceptance test procedure. Where an emergency responder radio coverage system is required, and upon completion of installation, the building *owner* shall have the radio system tested to verify that two-way coverage on each floor of the building is not less than 95 percent. The test procedure shall be conducted as follows:

1. Each floor of the building shall be divided into a grid of 20 approximately equal test areas.
2. The test shall be conducted using a calibrated portable radio of the latest brand and model used by the agency talking through the agency's radio communications system or equipment approved by the fire code official.
3. Failure of more than one test area shall result in failure of the test.
4. In the event that two of the test areas fail the test, in order to be more statistically accurate, the floor shall be permitted to be divided into 40 equal test areas. Failure of not more than two nonadjacent test areas shall not result in failure of the test. If the system fails the 40-area test, the system shall be altered to meet the 95-percent coverage requirement.
5. A test location approximately in the center of each test area shall be selected for the test, with the radio enabled to verify two-way communications to and from the outside of the building through the public agency's radio communications system. Once the test location has been selected, that location shall represent the entire test area. Failure in the selected test location shall be considered to be a failure of that test area. Additional test locations shall not be permitted.
6. The gain values of all amplifiers shall be measured and the test measurement results shall be kept on file with the building *owner* so that the measurements can be verified during annual tests. In the event that the measurement results become lost, the building *owner* shall be required to rerun the acceptance test to reestablish the gain values.
7. As part of the installation, a spectrum analyzer or other suitable test equipment shall be utilized to ensure spurious oscillations are not being generated by the subject signal booster. This test shall be conducted at the time of installation and at subsequent annual inspections.
8. ~~Systems incorporating Class B signal booster devices or Class B broadband fiber remote devices~~ shall be tested using two portable radios simultaneously conducting subjective voice quality checks. One portable radio shall be positioned not greater than 10 feet (3048 mm) from the indoor antenna. The second portable radio shall be positioned at a distance that represents the farthest distance from any indoor antenna. With both portable radios simultaneously keyed up on different frequencies within the same band, subjective audio testing shall be conducted and comply with DAQ levels as specified in Sections 510.4.1.1 and 510.4.1.2.

Reason:

This is one of 10 proposals being submitted as a package relating to technical changes proposed for Section 510. While the Fire Code Committee will consider each proposal independently, the intent is for approval of all proposals in this package which have been submitted as a correlated set of companion code change proposals.

This proposal is submitted by the ICC Fire Code Action Committee (FCAC). The FCAC was established by the ICC Board of Directors to pursue opportunities to improve and enhance assigned International Codes with regard to fire safety and hazardous materials in new and existing buildings and facilities and the protection of life and property in wildland urban interface areas. In 2017 the Fire-CAC has held 3 open meetings. In addition, there were numerous conference calls, Regional Work Group and Task Group meetings for the current code development cycle, which included members of the committees as well as any interested parties, to discuss and debate the proposed changes. Related documentation and reports are posted on the FCAC website at: <https://www.iccsafe.org/codes-tech-support/cs/fire-code-action-committee-fcac/>

Removing the code language "incorporating Class B signal-booster devices or Class B broadband fiber remote devices" is intended to clarify that the near-far effect should be a factor when testing each in-building public safety communications system. As currently worded, some might perceive that if using a channelized BDA (Bi-Directional Amplifier) at the headend feeding a fiber DAS (Distributed Antenna System), then they have met code. While

channelized feeding a fiber DAS is not as bad as class B feeding a passive DAS, the fact is that near-far is still a problem unless the fiber remote also has class A and the system should be tested.

Cost Impact

The code change proposal will not increase or decrease the cost of construction .

As the reason statement noted it might be perceive that if using a channelized BDA (Bi-Directional Amplifier) at the head-end feeding a fiber DAS (Distributed Antenna System), then they have met code. While channelized feeding a fiber DAS is not as bad as class B feeding a passive DAS, the fact is that near-far is still a problem unless the fiber remote also has class A and the system should be tested. Therefore this is simply clarifying what is intended by this section by removing this language therefore the cost should not be increased.

Internal ID: 974

F57-18

IFC: SECTION 601, SECTION 602, 603, 604, 605, 606, 607, 608, SECTION 609

Proponent: Michael O'Brian, Chair, representing FCAC (fcac@iccsafe.org)

2018 International Fire Code

SECTION 601 GENERAL

SECTION 602 DEFINITIONS

Revise as follows:

SECTION ~~604~~603 ELECTRICAL EQUIPMENT, WIRING AND HAZARDSSYSTEMS

SECTION ~~606~~ ~~604~~ ELEVATOR OPERATION, MAINTENANCE AND FIRE SERVICE KEYS ~~ELEVATORS~~

SECTION ~~603~~605 FUEL-FIRED APPLIANCES AND SYSTEMS

SECTION ~~607~~606 COMMERCIAL KITCHEN HOODS COOKING EQUIPMENT AND SYSTEMS

SECTION ~~608~~607 COMMERCIAL KITCHEN COOKING COOKING OIL STORAGE

SECTION ~~605~~608 MECHANICAL REFRIGERATION

SECTION 609 HYPERBARIC FACILITIES

Reason:

This is one of 17 proposals being submitted as a package relating to technical and organizational changes proposed for Chapter 6. While the Fire Code Committee will consider each proposal independently, the intent is for approval of all proposals in this package which have been submitted as a correlated set of companion code change proposals.

The Sections are reorganized within the Chapter to follow a more logical sequence addressing building systems and their construction and/or installation, operation, inspection and maintenance requirements and associated hazard mitigation requirements.

The order of requirements within each section are reorganized as part of the "technical" changes for each section through separate code proposals. The goal is to have a "general" or "scope" subsection followed by hazard mitigation requirements, as these requirements are most important to the fire code official. The construction, inspection, testing, operation, and maintenance requirements should follow a logical order for each respective system. In addition to creating a more logical order within both this Chapter and each section, the titles for individual sections are revised to more accurately reflect what is covered within each section.

Electrical equipment, wiring and systems - Hazards are covered in all sections, and is not needed in the title. This section not only includes equipment and wiring, but also full systems.

Elevators - Operation and maintenance are covered in all sections, and is part of the overall scope of the entire Chapter. Fire service keys are one of several components of elevators, and is not necessary to be included in the title.

Fuel-fired appliances and systems - This section not only includes appliances, but also full systems, including chimneys, vents, fuel piping, and fuel storage.

Commercial cooking equipment and systems - This section not only includes hoods, but also grease filters, cooking appliances, and grease ducts.

Commercial cooking oil storage - The storage of cooking oil is not limited to the kitchen area.

This proposal is submitted by the ICC Fire Code Action Committee (FCAC). The FCAC was established by the ICC Board of Directors to pursue opportunities to improve and enhance assigned International Codes with regard to fire safety and hazardous materials in new and existing buildings and facilities and the protection of life and property in wildland urban interface areas. In 2017 the Fire-CAC has held 3 open meetings. In addition, there were numerous conference calls, Regional Work Group and Task Group meetings for the current code development cycle, which included members of the committees as well as any interested parties, to discuss and debate the proposed changes. Related documentation and reports are posted on the FCAC website at: <https://www.iccsafe.org/codes-tech-support/cs/fire-code-action-committee-fcac/>

Cost Impact

The code change proposal will not increase or decrease the cost of construction .

No technical changes are proposed. This proposal reorders Chapter 6, and the changes to titles clarifies the contents of each section.

Internal ID: 513

F58-18

IFC: 601.1, 601.3 (New), 601.3.1 (New), 602.1

Proponent: Michael O'Brian, Chair, representing FCAC (fcac@iccsafe.org)

2018 International Fire Code

Revise as follows:

601.1 Scope. The provisions of this chapter shall apply to the installation, operation and maintenance of ~~fuel of the~~ following building services and systems:

1. Electrical systems, equipment and wiring;
2. Information technology server rooms;
3. Elevator systems, emergency operation and recall;
4. Fuel-fired appliances and heating systems, electrical systems and equipment, mechanical refrigeration systems, elevator recall and commercial kitchen equipment, chimneys and fuel oil storage;
5. Commercial cooking equipment and systems;
6. Commercial cooking oil storage;
7. Mechanical refrigeration systems; and
8. Hyperbaric facilities.

Add new text as follows:

601.3 Hazard abatement. Operations or conditions deemed unsafe or hazardous by the fire code official shall be abated. Equipment, appliances, materials, and systems that are modified or damaged and constitutes an electrical shock or fire hazard shall not be used.

601.3.1 Correction of unsafe conditions. The fire code official shall be authorized to require the owner, the owner's authorized agent, operator or occupant of a building or premises to abate or cause to be abated or corrected such unsafe operations or conditions either by repair, rehabilitation, demolition or other approved corrective action in compliance with this code.

Revise as follows:

602.1 Definitions. The following terms are defined in Chapter 2:

COMMERCIAL COOKING APPLIANCES.

~~CRITICAL CIRCUIT.~~

HOOD.

- **Type I.**
- ~~Type II.~~
-

REFRIGERANT .

REFRIGERATING (REFRIGERATION) SYSTEM.

Reason:

This is one of 17 proposals being submitted as a package relating to technical and organizational changes proposed for Chapter 6. While the Fire Code Committee will consider each proposal independently, the intent is for approval of all proposals in this package which have been submitted as a correlated set of companion code change proposals.

Section 601.1 is expanded, and presented in a numbered format, to clarify what building services and systems are covered by Chapter 6. Electrical systems also include wiring. Information technology server rooms are proposed in a separate proposal to address the unique requirements. Besides elevator recall, systems and emergency operations are covered. Besides fuel-fired appliances and systems, chimneys and fuel oil storage are covered. The section for commercial kitchens also includes requirements for the exhaust system and the cooking equipment.

A new section is added to address general abatement of hazards and unsafe conditions for all building services and systems. The new Section 601.3 is based on the existing Section 604.1. The new Section 601.3.1 is based on the existing Section 110.4. The purpose of these sections is to establish the fire code official's authority, to identify who is doing the correction of the unsafe conditions, and to establish what criteria is to be followed for the corrections.

The terms "critical circuit" and "Hood Type II" are proposed to be removed from Section 602 because these terms were removed from Chapter 6 in the 2018 code edition.

This proposal is submitted by the ICC Fire Code Action Committee (FCAC). The FCAC was established by the ICC Board of Directors to pursue opportunities to improve and enhance assigned International Codes with regard to fire safety and hazardous materials in new and existing buildings and facilities and the protection of life and property in wildland urban interface areas. In 2017 the Fire-CAC has held 3 open meetings. In addition, there were numerous conference calls, Regional Work Group and Task Group meetings for the current code development cycle, which included members of the committees as well as any interested parties, to discuss and debate the proposed changes. Related documentation and reports are posted on the FCAC website at: <https://www.iccsafe.org/codes-tech-support/cs/fire-code-action-committee-fcac/>

Cost Impact

The code change proposal will not increase or decrease the cost of construction .

This proposal provides clarity regarding the scope of Chapter 6, and removes definitions of terms not used in the Chapter. This proposal provides clarity on hazard abatement and addressing unsafe conditions.

Internal ID: 404

F59-18

IFC: 605.2

Proponent: Michael O'Brian, Chair, representing FCAC (fcac@iccsafe.org)

2018 International Fire Code

Delete without substitution:

~~**601.2 Permits.** Permits shall be obtained for refrigeration systems, battery systems and solar photovoltaic power systems as set forth in Sections 105.6 and 105.7.~~

Add new text as follows:

605.2 Permits. Permits shall be obtained for refrigeration systems as set forth in Sections 105.6 and 105.7.

Reason:

This is one of 17 proposals being submitted as a package relating to technical and organizational changes proposed for Chapter 6. While the Fire Code Committee will consider each proposal independently, the intent is for approval of all proposals in this package which have been submitted as a correlated set of companion code change proposals.

The requirements for battery systems and solar photovoltaic power systems were relocated to a new Chapter 12 in the last code cycle. The only remaining requirement for specific operational and construction permits are for refrigeration systems. Those requirements for refrigeration system permits are proposed to be relocated into the mechanical refrigeration Section 605.

This proposal is submitted by the ICC Fire Code Action Committee (FCAC). The FCAC was established by the ICC Board of Directors to pursue opportunities to improve and enhance assigned International Codes with regard to fire safety and hazardous materials in new and existing buildings and facilities and the protection of life and property in wildland urban interface areas. In 2017 the Fire-CAC has held 3 open meetings. In addition, there were numerous conference calls, Regional Work Group and Task Group meetings for the current code development cycle, which included members of the committees as well as any interested parties, to discuss and debate the proposed changes. Related documentation and reports are posted on the FCAC website at: <https://www.iccsafe.org/codes-tech-support/cs/fire-code-action-committee-fcac/>

Cost Impact

The code change proposal will not increase or decrease the cost of construction .

There are no changes to the requirements for permits. The requirements are simply relocated to the sections that apply.

Internal ID: 405

F60-18

IFC: 603.1, 603.1.1, 603.1.2, 603.1.3, 603.1.4, 603.1.5, 603.1.5.1, 603.1.5.2, 603.1.6

Proponent: Michael O'Brian, Chair, representing FCAC (fcac@iccsafe.org)

2018 International Fire Code

Revise as follows:

603.1 Installation-General. ~~The design, construction, installation, operation, alteration, repair, and maintenance of nonportable gas-fired appliances and systems shall comply with the provisions of this section and the International Fuel Gas Code. The design, construction, installation of nonportable liquid fuel-fired, operation, alteration, repair, and maintenance of nonportable solid-fuel-fired and oil-fired appliances and systems shall comply with the provisions of this section and the International Mechanical Code. The installation of all other construction and use of portable fuel-fired appliances, other than portable internal combustion engines, oil lamps and other portable devices not connected to a fixed fuel piping system, such as blow torches, melting pots and weed burners, shall comply with this section and the International Mechanical Code section.~~

603.1.1 Manufacturer's instructions-Installation of nonportable fuel-fired appliances. ~~The installation of nonportable fuel-fired appliances shall be made in accordance with the manufacturer's installation instructions and applicable federal, state and local rules and regulations. Where it becomes necessary to change, modify or alter a manufacturer's instructions in any way, written approval shall first be obtained from the manufacturer.~~

Delete without substitution:

603.1.2 Approval. ~~The design, construction and installation of fuel-fired appliances shall be in accordance with the International Fuel Gas Code and the International Mechanical Code.~~

Revise as follows:

~~603.1.3~~ **603.1.2 Electrical wiring and equipment.** Electrical wiring and equipment used in connection with ~~oil fuel-burning-fired appliances and~~ equipment shall be installed and maintained in accordance with Section 604 and NFPA 70.

~~603.1.4~~ **603.1.3 Fuel oil.** The grade of fuel oil used in ~~a~~ an oil burner shall be that for which the oil burner is *approved* and as stipulated by the oil burner manufacturer's instructions. Oil containing gasoline shall not be used. Waste crankcase oil shall be an acceptable fuel in Group F, M and S occupancies where utilized in equipment *listed and labeled* for use with waste oil and where such equipment is installed in accordance with the manufacturer's instructions and the terms of its listing.

~~603.1.5~~ **603.1.4 Access.** The installation of fuel fired equipment shall be provided with access to equipment for cleaning hot surfaces; removing burners; replacing motors, controls, air filters, chimney and vent connectors, draft regulators and other working parts; and for adjusting, cleaning and lubricating parts.

~~603.1.6~~ **603.1.5 Testing, diagrams and instructions.** After installation of the ~~oil fuel-burning-fired~~ equipment, operation and combustion performance tests shall be conducted to determine that the burner equipment is in proper operating condition and that all accessory equipment, controls, and safety devices function properly.

~~603.1.6.1~~ **603.1.5.1 Diagrams.** Contractors installing industrial oil-burning systems shall furnish not less than two copies of diagrams showing the main oil lines and controlling valves, one copy of which shall be posted at the oil-burning equipment and another at an *approved* location that will be available in case of emergency.

~~603.1.6.2~~ **603.1.5.2 Instructions-Operating instructions.** After completing the installation, the installer shall instruct the *owner* or operator in the proper operation of the equipment. The installer shall furnish the *owner* or operator with the ~~name and telephone number of persons to contact for technical information or assistance and routine or emergency services~~ manufacturer's operating instructions.

~~603.1.7~~ **603.1.6 Clearances.** Working clearances between ~~oil~~ fuel-fired appliances and electrical panelboards and equipment shall be in accordance with NFPA 70. Clearances between oil-fired equipment and oil supply tanks shall be in accordance with NFPA 31.

Reason:

This is one of 17 proposals being submitted as a package relating to technical and organizational changes proposed for Chapter 6. While the Fire Code Committee will consider each proposal independently, the intent is for approval of all proposals in this package which have been submitted as a correlated set of companion code change proposals.

The following changes are proposed:

1. Scoping and general installation requirements - Provides a general scoping section, aligning the scoping of the International Fuel Gas Code and international Mechanical Code with the Fire Code. The scope is expanded to include operation, repairs, and maintenance, besides the existing installation requirements. The scope of the section is expanded to include solid-fuel-fired appliances (only gas-fired and oil-fired appliances are covered in the existing code)
2. Installation instructions - Approval is from the fire code official, not the manufacturer.
3. Approval - Delete existing Section 603.1.2 because this is a repeat of Section 603.1.
4. Electrical wiring and equipment, access, testing diagrams and instructions and clearances expanded to also apply to solid-fuel fired and gas-fired appliances and equipment. These general requirements apply to all types of fuel-fired appliances and equipment, not just oil-fired.
5. Instructions (604.1.6.2) - the installer should be leaving the operating instructions for the owner or operator of the equipment.

Cost Impact

The code change proposal will not increase or decrease the cost of construction .

The proposal aligns the provisions of this section with already existing requirements in other codes, and provides clarity on the scope of this section.

Internal ID: 500

F61-18

IFC: 603.2

Proponent: Michael O'Brian, Chair, representing FCAC (fcac@iccsafe.org)

2018 International Fire Code

Revise as follows:

603.2 Chimneys. ~~Chimneys and vents.~~ Masonry chimneys shall be constructed in accordance with the International Building Code. Factory-built chimneys and vent systems shall be installed in accordance with the International Mechanical Code. Metal chimneys shall be constructed and installed in accordance with ~~NFPA 211, the~~ International Mechanical Code. Gas vents serving gas-fired appliances shall be installed in accordance with the International Fuel Gas Code.

Reason:

This is one of 17 proposals being submitted as a package relating to technical and organizational changes proposed for Chapter 6. While the Fire Code Committee will consider each proposal independently, the intent is for approval of all proposals in this package which have been submitted as a correlated set of companion code change proposals.

Vent systems, such as Type B, BW, and L, need to also be included for fuel-fired appliances and equipment. This proposal aligns the chimney and vent provisions with the IMC and IFGC.

This proposal is submitted by the ICC Fire Code Action Committee (FCAC). The FCAC was established by the ICC Board of Directors to pursue opportunities to improve and enhance assigned International Codes with regard to fire safety and hazardous materials in new and existing buildings and facilities and the protection of life and property in wildland urban interface areas. In 2017 the Fire-CAC has held 3 open meetings. In addition, there were numerous conference calls, Regional Work Group and Task Group meetings for the current code development cycle, which included members of the committees as well as any interested parties, to discuss and debate the proposed changes. Related documentation and reports are posted on the FCAC website at: <https://www.iccsafe.org/codes-tech-support/cs/fire-code-action-committee-fcac/>

Cost Impact

The code change proposal will not increase or decrease the cost of construction .

Aligns the requirements for chimneys and vents with already existing requirements.

Internal ID: 504

F62-18

IFC: 603.2, 603.2.1, 603.2.1.1, 603.2.1.2, 603.2.1.3, 603.2.1.4, 603.2.1.5

Proponent: Michael O'Brian, Chair, representing FCAC (fcac@iccsafe.org)

2018 International Fire Code

Revise as follows:

~~603.7~~ **603.2 Discontinuing operation-Abatement of unsafe heating appliances-conditions.** The *fire code official* is authorized to order that measures be taken to prevent the operation of any existing stove, oven, furnace, incinerator, boiler or any other heat-producing device or appliance found to be defective or in violation of code requirements for existing appliances after giving notice to this effect to any person, *owner*, firm or agent or operator in charge of the same. The *fire code official* is authorized to take measures to prevent the operation of any device or appliance without notice when inspection shows the existence of an immediate fire hazard or when imperiling human life. The defective device shall remain withdrawn from service until all necessary repairs or *alterations* have been made or replaced in accordance with Section 603.1.

~~603.6~~ **603.2.1 Chimneys and appliances.** Chimneys, vents, incinerators, smokestacks or similar devices for conveying smoke or hot gases to the outer air and the appliances, such as stoves, furnaces, fireboxes or boilers to which such devices are connected, shall be maintained so as not to create a fire hazard.

~~603.6.1~~ **603.2.1.1 Masonry chimneys.** Masonry chimneys that, upon inspection, are found to be without a flue liner and that have open mortar joints which will permit smoke or gases to be discharged into the building, or which are cracked as to be dangerous, shall be repaired or relined with a *listed* chimney liner system installed in accordance with the manufacturer's instructions and the International Mechanical Code, or a flue lining system installed in accordance with the requirements of the International Building Code and appropriate for the intended class of chimney service.

~~603.6.2~~ **603.2.1.2 Metal chimneys.** Metal chimneys that are corroded or improperly supported shall be repaired or replaced in accordance with the International Mechanical Code.

~~603.6.3~~ **603.2.1.3 Decorative shrouds.** Decorative shrouds installed at the termination of factory-built chimneys or vents shall be removed except where such shrouds are *listed* and *labeled* for use with the specific factory-built chimney system and are installed in accordance with the chimney or vent manufacturer's instructions and the International Mechanical Code or International Fuel Gas Code.

~~603.6.4~~ **603.2.1.4 Factory-built chimneys-chimneys and vent systems.** Existing factory-built chimneys and vent systems that are damaged, corroded or improperly supported shall be repaired or replaced in accordance with the International Mechanical Code.

~~603.6.5~~ **603.2.1.5 Connectors.** Existing chimney and vent connectors that are damaged, corroded or improperly supported shall be repaired or replaced in accordance with the International Mechanical Code.

Reason:

This is one of 17 proposals being submitted as a package relating to technical and organizational changes proposed for Chapter 6. While the Fire Code Committee will consider each proposal independently, the intent is for approval of all proposals in this package which have been submitted as a correlated set of companion code change proposals.

The existing sections for Discontinuing operation of unsafe heating appliances (Section 603.7) and Chimneys and appliances (Section 603.6) are relocated to directly follow the general installation requirements in Section 603.1, to provide a logical order for enforcement of the code. The requirements in Chimneys and appliances (Section 603.6) are relocated as subsections to the section on unsafe conditions, because these requirements are about recognizing and abating specific unsafe conditions. These requirements are expanded to include vent systems, and to direct the repairs in accordance with the IMC and the IFGC.

This proposal is submitted by the ICC Fire Code Action Committee (FCAC). The FCAC was established by the ICC Board of Directors to pursue opportunities to improve and enhance assigned International Codes with regard to fire safety and hazardous materials in new and existing buildings and facilities and the protection of life and property in wildland urban interface areas. In 2017 the Fire-CAC has held 3 open meetings. In addition, there were numerous conference calls, Regional Work Group and Task Group meetings for the current code development cycle, which included members of the committees as well as any interested parties, to discuss and debate the proposed changes. Related documentation and reports are posted on the FCAC website at: <https://www.iccsafe.org/codes-tech-support/cs/fire->

code-action-committee-fcac/

Cost Impact

The code change proposal will not increase or decrease the cost of construction .

No technical changes to already existing requirements.

Internal ID: 512

F63-18

IFC: 603.3, 603.3.1, 603.3.1.1 (New), 603.3.2, 603.3.2.1, 603.3.2.2, 603.3.2.3, 603.3.2.4, 603.3.2.5, 603.3.2.6, 603.3.2.7, 603.3.3, Chapter 80

Proponent: Michael O'Brian, Chair, representing FCAC (fcac@iccsafe.org)

2018 International Fire Code

Revise as follows:

603.3 Fuel oil storage systems. Fuel oil storage systems for building heating systems shall be installed and maintained in accordance with this code. ~~Fuel tanks and fuel-oil piping systems~~ shall be installed in accordance with Chapter 13 of the International Mechanical Code.

603.3.1 Fuel oil storage in outside, above-ground tanks. Where connected to a fuel-oil piping system, the maximum amount of fuel oil storage allowed outside above ground without additional protection shall be 660 gallons (2498 L). The storage of fuel oil above ground in quantities exceeding 660 gallons (2498 L) shall comply with NFPA 31.

Add new text as follows:

603.3.1.1 Approval. Outside Fuel oil storage tanks shall be in accordance with UL142 or UL 2085.

Revise as follows:

603.3.2 Fuel oil storage inside buildings. Fuel oil storage inside buildings shall comply with Sections 603.3.2.1 through 603.3.2.5 or Chapter 57: of this code.

Add new text as follows:

603.3.2.1 Approval. Inside Fuel oil storage tanks shall be in accordance with UL 80, UL 142, UL 443, or UL 2085.

Revise as follows:

~~603.3.2.1~~ **603.3.2.2 Quantity limits.** One or more fuel oil storage tanks containing Class II or III *combustible liquid* shall be permitted in a building. The aggregate capacity of all tanks shall not exceed the following:

1. 660 gallons (2498 L) in unsprinklered buildings, where stored in a tank complying with UL 80, UL 142, UL 443, or UL 2085.
2. 1,320 gallons (4996 L) in buildings equipped with an *automatic sprinkler* system in accordance with Section 903.3.1.1, where stored in a tank complying with UL 142.
3. 3,000 gallons (11 356 L) in buildings equipped with an automatic sprinkler system in accordance with Section 903.3.1.1, where stored in protected above-ground tanks complying with UL 2085 and Section 5704.2.9.7 ~~and the room is protected by an automatic sprinkler system in accordance with Section 903.3.1.1. of this code.~~

603.3.2.2 Restricted use and connection. Tanks installed in accordance with Section 603.3.2 shall be used only to supply fuel oil to fuel-burning equipment, generators or fire pumps installed in accordance with Section 603.3.2.4. Connections between tanks and equipment supplied by such tanks shall be made using closed piping ~~systems~~ systems in accordance with the International Mechanical Code.

603.3.2.3 Applicability of maximum allowable quantity and control area requirements. The quantity of *combustible liquid* stored in tanks complying with Section 603.3.2 shall not be counted towards the maximum allowable quantity set forth in Table 5003.1.1(1), and such tanks shall not be required to be located in a *control area*.

603.3.2.4 Installation. Tanks and piping systems shall be installed in accordance with Section 915 and Chapter 13, both of the International Mechanical Code, as applicable.

603.3.2.5 Separation. Rooms containing fuel oil tanks for internal combustion engines shall be separated from the remainder of the building by *fire barriers, horizontal assemblies*, or both, with a minimum 1-hour fire-resistance rating with 1-hour fire-protection-rated *opening protectives* constructed in accordance with the International Building Code.

Exception: Rooms containing protected above-ground tanks complying with Section 5704.2.9.7 of this code shall

not be required to be separated from surrounding areas.

603.3.2.6 Spill containment. Tanks exceeding ~~55-60~~ gallon (~~208-227~~ L) capacity or an aggregate capacity of 1,000 gallons (3785 L) that are not provided with integral secondary containment shall be provided with spill containment sized to contain a release from the largest tank.

603.3.2.7 Tanks in basements. Tanks in *basements* shall be in accordance with UL 80 and shall be located not more than two stories below grade plane.

603.3.3 ~~Underground storage of fuel oil.~~ Fuel oil storage in underground tanks. The storage of fuel oil in underground storage tanks shall comply with UL 58 or UL 1316 and installed in accordance with NFPA 31.

Add new standard(s) follows:

UL

Underwriters Laboratories LLC
333 Pfingsten Road
Northbrook IL 60062

443-06:

Steel Auxiliary Tanks for Oil-Burner Fuel (with revisions through March 8, 2013)

Reason:

This is one of 17 proposals being submitted as a package relating to technical and organizational changes proposed for Chapter 6. While the Fire Code Committee will consider each proposal independently, the intent is for approval of all proposals in this package which have been submitted as a correlated set of companion code change proposals.

This proposal provides the following clarity:

1. The scope of these sections is for fuel oil storage systems for building heating systems, not for generators or fire pumps.
2. These sections cover both installation and maintenance.
3. Both tanks and fuel oil piping systems are covered in Chapter 13 of the IMC.
4. Identifies what standards that the fuel oil storage tanks located outside, inside, and underground are required to comply.
5. Adds UL 443, UL 58, and UL 1316 as additional alternative standards for tanks to comply.
6. Correlates in Section 603.3.2.6 the technical requirements with the definitions of containers (a vessel of 60 gallons or less) and tanks (a vessel more than 60 gallons).

CONTAINER. A vessel of 60 gallons (227 L) or less in capacity used for transporting or storing hazardous materials. Pipes, piping systems, engines and engine fuel tanks are not considered to be containers.

TANK. A vessel containing more than 60 gallons (227 L).

This proposal is submitted by the ICC Fire Code Action Committee (FCAC). The FCAC was established by the ICC Board of Directors to pursue opportunities to improve and enhance assigned International Codes with regard to fire safety and hazardous materials in new and existing buildings and facilities and the protection of life and property in wildland urban interface areas. In 2017 the Fire-CAC has held 3 open meetings. In addition, there were numerous conference calls, Regional Work Group and Task Group meetings for the current code development cycle, which included members of the committees as well as any interested parties, to discuss and debate the proposed changes. Related documentation and reports are posted on the FCAC website at: <https://www.iccsafe.org/codes-tech-support/cs/fire-code-action-committee-fcac/>

Cost Impact

The code change proposal will not increase or decrease the cost of construction .

Clarifies existing requirements, and provides additional alternative compliance paths for the tanks.

Analysis: A review of the standard proposed for inclusion in the code, UL 443-06 with revisions through March 8, 2013, with regard to the ICC criteria for referenced standards (Section 3.6 of CP#28) will be posted on the ICC website on or before April 2, 2018.

Internal ID: 409

F64-18

IFC: 603.3.2.1

Proponent: Bob Morgan, Fort Worth Fire Department, representing Fort Worth Fire Department

2018 International Fire Code

Revise as follows:

603.3.2.1 Quantity limits. One or more fuel oil storage tanks containing Class II or III *combustible liquid* shall be permitted in a building. The aggregate capacity of all tanks shall not exceed the following:

1. 660 gallons (2498 L) in unsprinklered buildings, where stored in a tank complying with UL 80, UL 142 or UL 2085.
2. 1,320 gallons (4996 L) in buildings equipped with an *automatic sprinkler* system in accordance with Section 903.3.1.1, where stored in a tank complying with UL 142- as a listed secondary containment tank. Secondary containment shall be monitored visually or automatically.
3. 3,000 gallons (11 356 L) where stored in protected above-ground tanks complying with UL 2085 and Section 5704.2.9.7 and the room is protected by an *automatic sprinkler system* in accordance with Section 903.3.1.1. Secondary containment shall be monitored visually or automatically.

Reason:

The current allowance of 1,320 gallons in a single wall tank in a non-Group H occupancy area is simply not consistent with historical practice for such installations and is not equivalent to what is required in Chapter 50 relative to maximum allowable quantities, which would normally only allow up to 240 gallons in a fully sprinklered non-Group H occupancy in a use-closed system.

Additionally, the vast majority of these tanks presently installed inside and outside buildings are of the double-wall type for permanent installations.

Primary concern is the exposure of 1,320 gallons of spilled diesel (fuel oil - Class II combustible liquid) inside a building, resulting in much greater involvement in a fire condition than in the vented interstitial space of a double-wall tank.

The double-wall tank provides an added layer of protection at a reasonable cost and is common industry practice currently, especially when located inside a building.

Cost Impact

The code change proposal will increase the cost of construction .

The vast majority of fuel tanks associated with generators and fire pumps are of the double-wall type presently; however, being that the code currently allows these to be of the single wall type for the maximum 1,320 gallon designated quantity, the requirement of double-wall would be an increase in the cost of construction as a result.

Internal ID: 438

F65-18

IFC: 603.4, 603.4.2.1, 603.4.2.1.1, 603.4.2.2, 603.4.2.2.1, 603.4.2.2.2, 603.4.2.2.3, 603.4.2.2.4, Chapter 80

Proponent: Michael O'Brian, Chair, representing FCAC (fcac@iccsafe.org)

2018 International Fire Code

603.4 Portable unvented heaters. Portable unvented fuel-fired heating equipment shall be prohibited in occupancies in Groups A, E, I, R-1, R-2, R-3 and R-4 and ambulatory care facilities.

Exceptions:

1. ~~In one- and two-family dwellings portable~~ Portable unvented fuel-fired heaters, ~~where approved and listed in accordance with UL 647~~ are permitted to be used in one- and two-family dwellings, where operated and maintained in accordance with the manufacturer's instructions.
2. Portable outdoor gas-fired heating appliances in accordance with Section 603.4.2.

Revise as follows:

603.4.2.1 Location. Portable outdoor gas-fired heating appliances shall be used and located in accordance with Sections 603.4.2.1.1 through 603.4.2.1.4.

603.4.2.1.1 Prohibited locations. The storage or use of portable outdoor gas-fired heating appliances is prohibited in any of the following locations:

1. Inside of any occupancy where connected to the fuel gas container.
2. Inside of tents, canopies and membrane structures.
3. On exterior balconies.

Exception: ~~As allowed permitted in Section 6.22 of NFPA 58 Chapter 61 of this code.~~

603.4.2.2 Installation Use and operation. Portable outdoor gas-fired heating appliances shall be ~~installed~~ used and operated in accordance with Sections 603.4.2.2.1 through 603.4.2.2.4.

603.4.2.2.1 Listing and approval. Only *listed* and *approved* portable outdoor gas-fired heating appliances utilizing a fuel gas container that is integral to the appliance shall be used. Portable outdoor gas-fired heating appliances shall be listed and labeled in accordance with ANSI Z83.26/CSA 2.37 or ANSI Z21.58/CSA 1.6.

603.4.2.2.2 Installation Use and maintenance. Portable outdoor gas-fired heating appliances shall be ~~installed~~ used and maintained in accordance with the manufacturer's instructions.

Delete without substitution:

~~**603.4.2.2.3 Tip-over switch.** Portable outdoor gas-fired heating appliances shall be equipped with a tilt or tip-over switch that automatically shuts off the flow of gas if the appliance is tilted more than 15 degrees (0.26 rad) from the vertical.~~

~~**603.4.2.2.4 Guard against contact.** The heating element or combustion chamber of portable outdoor gas-fired heating appliances shall be permanently guarded so as to prevent accidental contact by persons or material.~~

Add new standard(s) follows:

ANSI

American National Standards
Institute
25 West 43rd Street, 4th Floor
New York NY 10036

ANSI Z83.26/CSA 2.37-2014:

Gas-Fired Outdoor Infrared Patio Heaters

ANSI Z21.58/CSA 1.6-2015:

Outdoor Cooking Gas Appliances

Reason:

This is one of 17 proposals being submitted as a package relating to technical and organizational changes proposed for Chapter 6. While the Fire Code Committee will consider each proposal independently, the intent is for approval of all proposals in this package which have been submitted as a correlated set of companion code change proposals.

This proposal addresses the following for portable unvented heaters and outdoor gas-fired heating appliances:

1. Replaces "installed" with "used", because these are portable products.
2. For listed portable unvented heaters in one- and two-family dwellings, the fire code official will not be present to approve the use. The requirements have been expanded to also require these heaters to be operated and maintained in accordance with the manufacturer's instructions, which are part of the listing of the heater.
3. Adds specific standards for the portable outdoor gas-fired heating appliances.
4. Removes the tip-over switch requirement (Section 603.4.2.2.3) because this is already a requirement in ANSI Z83.26/CSA 2.37 (Section 5.19). The listing standard includes a performance test to determine.
5. Removes the guard requirement (Section 603.4.2.2.4) because this is already a requirement in ANSI Z83.26/CSA 2.37 (Section 5.14). The listing standard includes requirements addressing accessibility to any heated surface (Section 5.14).

This proposal is submitted by the ICC Fire Code Action Committee (FCAC). The FCAC was established by the ICC Board of Directors to pursue opportunities to improve and enhance assigned International Codes with regard to fire safety and hazardous materials in new and existing buildings and facilities and the protection of life and property in wildland urban interface areas. In 2017 the Fire-CAC has held 3 open meetings. In addition, there were numerous conference calls, Regional Work Group and Task Group meetings for the current code development cycle, which included members of the committees as well as any interested parties, to discuss and debate the proposed changes. Related documentation and reports are posted on the FCAC website at: <https://www.iccsafe.org/codes-tech-support/cs/fire-code-action-committee-fcac/>

Cost Impact

The code change proposal will not increase or decrease the cost of construction .

Clarifies already existing requirements.

Analysis: A review of the standards proposed for inclusion in the code, ANSI Z83.26/CSA 2.37-2014 and ANSI Z21.58/CSA 1.6-2015, with regard to the ICC criteria for referenced standards (Section 3.6 of CP#28) will be posted on the ICC website on or before April 2, 2018.

Internal ID: 510

F66-18

IFC: 603.8.1, Chapter 80

Proponent: Michael O'Brian, Chair, representing FCAC (fcac@iccsafe.org)

2018 International Fire Code**Revise as follows:**

603.8.1 Residential incinerators. Residential incinerators shall be ~~of an approved type, listed and labeled in accordance with UL 791.~~

Add new standard(s) follows:**UL**

Underwriters Laboratories LLC
333 Pfingsten Road
Northbrook IL 60062

791-06:

Residential Incinerators - with revisions through November 2014

Reason:

This is one of 17 proposals being submitted as a package relating to technical and organizational changes proposed for Chapter 6. While the Fire Code Committee will consider each proposal independently, the intent is for approval of all proposals in this package which have been submitted as a correlated set of companion code change proposals.

This aligns with the International Mechanical Code, which requires, in Section 907.1, listing for residential incinerators to UL 791.

This proposal is submitted by the ICC Fire Code Action Committee (FCAC). The FCAC was established by the ICC Board of Directors to pursue opportunities to improve and enhance assigned International Codes with regard to fire safety and hazardous materials in new and existing buildings and facilities and the protection of life and property in wildland urban interface areas. In 2017 the Fire-CAC has held 3 open meetings. In addition, there were numerous conference calls, Regional Work Group and Task Group meetings for the current code development cycle, which included members of the committees as well as any interested parties, to discuss and debate the proposed changes. Related documentation and reports are posted on the FCAC website at: <https://www.iccsafe.org/codes-tech-support/cs/fire-code-action-committee-fcac/>

Cost Impact

The code change proposal will not increase or decrease the cost of construction .

Aligns the Fire code with already existing requirements in the IMC.

Internal ID: 509

F67-18

IFC: 603.10 (New), 603.10.1 (New), 603.10.2 (New)

Proponent: Richard Boisvert, Brighton Area Fire Authority, representing Michigan Fire Inspector's Society
(rboisvert@brightonareafire.com)

2018 International Fire Code

Add new text as follows:

603.10 Clothes dryer exhaust ducts. Clothes dryer exhaust ducts shall be in accordance with Sections 603.10.1 and 603.10.2.

603.10.1 Installation. Clothes dryer vent ducts shall be installed and maintained in accordance with the International Mechanical Code and the manufacturer's installation instructions.

603.10.2 Maintenance. The lint trap, mechanical and heating components, and the exhaust duct system of a clothes dryer shall be maintained to prevent the accumulation of lint or debris that prevents the exhaust of air, products of combustion or that creates a fire hazard.

Reason:

Th IFC does not specifically address clothes dryer exhaust duct system installation and maintenance. The addition of this section creates a clear code path to ensure these duct systems are maintained to prevent fires.

Cost Impact

The code change proposal will not increase or decrease the cost of construction .

This change will not affect the cost of construction, however, it will require additional maintenance costs to maintain them following installation.

Internal ID: 1086

F68-18

IFC: 604.1 (New), , 604.7

Proponent: Michael O'Brian, Chair, representing FCAC (fcac@iccsafe.org)

2018 International Fire Code

Add new text as follows:

604.1 General. Electrical equipment, wiring and systems required by this code or the International Building Code shall be installed, used and maintained in accordance with NFPA 70 and Sections 604.2 through 604.11.

Revise as follows:

~~**604.7604.1.1 Equipment and fixtures-wiring.** Electrical equipment and fixtures~~ All electrical equipment, wiring, devices, and appliances shall be tested and listed by an approved agency and labeled, and installed, used and maintained in accordance with NFPA 70 and all instructions included as part of such listing.

Reason:

This is one of 17 proposals being submitted as a package relating to technical and organizational changes proposed for Chapter 6. While the Fire Code Committee will consider each proposal independently, the intent is for approval of all proposals in this package which have been submitted as a correlated set of companion code change proposals.

This proposal provides scoping for the section for electrical equipment, wiring and systems, which are installed, used, and maintained in accordance with NFPA 70 and this section. The installation and listing of electrical equipment and wiring is relocated to the beginning of this section. The terms for all electrical products to be listed are updated to the current terms used and defined in NFPA 70.

This proposal is submitted by the ICC Fire Code Action Committee (FCAC). The FCAC was established by the ICC Board of Directors to pursue opportunities to improve and enhance assigned International Codes with regard to fire safety and hazardous materials in new and existing buildings and facilities and the protection of life and property in wildland urban interface areas. In 2017 the Fire-CAC has held 3 open meetings. In addition, there were numerous conference calls, Regional Work Group and Task Group meetings for the current code development cycle, which included members of the committees as well as any interested parties, to discuss and debate the proposed changes. Related documentation and reports are posted on the FCAC website at: <https://www.iccsafe.org/codes-tech-support/cs/fire-code-action-committee-fcac/>

Cost Impact

The code change proposal will not increase or decrease the cost of construction .

Proposal clarifies the scoping of this section. No technical requirements are added.

Internal ID: 464

F69-18

IFC: 604.1.1 (New)

Proponent: John Williams, Chair, representing Healthcare Committee (AHC@iccsafe.org)

2018 International Fire Code

Add new text as follows:

604.1.1 Healthcare facilities. In Group I-2 facilities, ambulatory care facilities and outpatient clinics, the electrical systems and equipment shall be maintained and tested in accordance with NFPA 99.

Reason:

In order to meet federal conditions of participation health care facilities must comply with the electrical systems and equipment maintenance and testing requirements listed in NFPA 99, Health Care Facilities Code (K913). This change will align the electrical systems maintenance and testing requirements for Outpatient Clinics, Group B Ambulatory Care and Group I-2 facilities.

This proposal is submitted by the ICC Committee on Healthcare (CHC). The CHC was established by the ICC Board to evaluate and assess contemporary code issues relating to healthcare facilities. This is a joint effort between ICC and the American Society for Healthcare Engineering (ASHE), a subsidiary of the American Hospital Association, to eliminate duplication and conflicts in healthcare regulation. In 2017 the CHC held 2 open meetings and numerous conference calls, which included members of the committees as well as any interested parties, to discuss and debate the proposed changes. Information on the CHC, including: meeting agendas; minutes; reports; resource documents; presentations; and all other materials developed in conjunction with the CHC effort can be downloaded from the CHC website at: <https://www.iccsafe.org/codes-tech-support/cs/icc-committee-on-healthcare/>.

Cost Impact

The code change proposal will not increase or decrease the cost of construction .

This change is an operational change regarding maintenance and testing. This will not increase the cost of construction on the healthcare industry.

Internal ID: 694

F70-18

IFC: 604.1, 604.2.1 (New), 604.6

Proponent: Michael O'Brian, Chair, representing FCAC (fcac@iccsafe.org)

2018 International Fire Code

Revise as follows:

~~**604.1604.2 Abatement of unsafe conditions and electrical hazards.** Identified electrical hazards shall be abated. Identified hazardous electrical conditions in permanent wiring shall be brought to the attention of the responsible code official. Electrical wiring, devices, appliances and other equipment that is modified or damaged and constitutes Conditions that constitute an electrical shock or fire hazard shall not be used.~~

Add new text as follows:

604.2.1 Modified or damaged. Electrical wiring, devices, appliances and equipment that are modified or damaged, and constitutes an electrical shock or fire hazard, shall not be used until repaired or replaced in accordance with this code and NFPA 70.

Revise as follows:

~~**604.6 604.2.2 Unapproved conditions. Open electrical terminations.**~~ Open junction boxes and open-wiring splices shall be prohibited. *Approved* covers shall be provided for all switch and electrical outlet boxes.

Reason:

This is one of 17 proposals being submitted as a package relating to technical and organizational changes proposed for Chapter 6. While the Fire Code Committee will consider each proposal independently, the intent is for approval of all proposals in this package which have been submitted as a correlated set of companion code change proposals.

This proposal relocates all the requirements regarding unsafe conditions together, and provides direction on the abatement of the unsafe conditions.

This proposal is submitted by the ICC Fire Code Action Committee (FCAC). The FCAC was established by the ICC Board of Directors to pursue opportunities to improve and enhance assigned International Codes with regard to fire safety and hazardous materials in new and existing buildings and facilities and the protection of life and property in wildland urban interface areas. In 2017 the Fire-CAC has held 3 open meetings. In addition, there were numerous conference calls, Regional Work Group and Task Group meetings for the current code development cycle, which included members of the committees as well as any interested parties, to discuss and debate the proposed changes. Related documentation and reports are posted on the FCAC website at: <https://www.iccsafe.org/codes-tech-support/cs/fire-code-action-committee-fcac/>

Cost Impact

The code change proposal will not increase or decrease the cost of construction .

Provides clarity on the abatement of unsafe conditions, and clarifies the existing requirements.

Internal ID: 466

F71-18

IFC: 604.3

Proponent: Michael O'Brian, Chair, representing FCAC (fcac@iccsafe.org)

2018 International Fire Code

Revise as follows:

604.3 Working space and ~~clearance, clearances.~~ ~~A working space of not less than~~ Working space around electrical equipment shall be provided in accordance with Section 110.26 of NFPA 70 for electrical equipment rated 1000V or less, and Section 110.33 of NFPA 70 for electrical equipment rated over 1000V. The minimum required working space shall not be less than 30 inches (762 mm) in width, 36 inches (914 mm) in depth and 78 inches (1981 mm) in height shall be provided in front of electrical service equipment. Where the electrical service equipment is wider than 30 inches (762 mm), the minimum working space shall be not less than the width of the equipment. Storage of materials shall not be located within the designated working space.

Exceptions:

- ~~1. Where other dimensions are required or allowed by NFPA 70.~~
- ~~2. Access openings into attics or under floor areas that provide a minimum clear opening of 22 inches (559 mm) by 30 inches (762 mm).~~

Reason:

This is one of 17 proposals being submitted as a package relating to technical and organizational changes proposed for Chapter 6. While the Fire Code Committee will consider each proposal independently, the intent is for approval of all proposals in this package which have been submitted as a correlated set of companion code change proposals.

This proposal aligns the working space and clearances requirements for electrical equipment with the requirements in NFPA 70.

This proposal is submitted by the ICC Fire Code Action Committee (FCAC). The FCAC was established by the ICC Board of Directors to pursue opportunities to improve and enhance assigned International Codes with regard to fire safety and hazardous materials in new and existing buildings and facilities and the protection of life and property in wildland urban interface areas. In 2017 the Fire-CAC has held 3 open meetings. In addition, there were numerous conference calls, Regional Work Group and Task Group meetings for the current code development cycle, which included members of the committees as well as any interested parties, to discuss and debate the proposed changes. Related documentation and reports are posted on the FCAC website at: <https://www.iccsafe.org/codes-tech-support/cs/fire-code-action-committee-fcac/>

Cost Impact

The code change proposal will not increase or decrease the cost of construction .

Clarifies already existing requirements, and ensures no conflict with NFPA 70.

Internal ID: 467

F72-18

IFC: 202 (New), 604.4, 604.4.1, 604.4.2, 604.4.3, 604.4.4 (New), 604.4.5 (New), Chapter 80

Proponent: Michael O'Brian, Chair, representing FCAC (fcac@iccsafe.org)

2018 International Fire Code

Add new definition as follows:

CURRENT TAP An electrical device that, where connected to a permanently installed receptacle outlet, provides multiple receptacle outlet configurations.

RELOCATABLE POWER TAP A relocatable electrical enclosure that provides one or more receptacle outlets and that is provided with an attached power supply cord and attachment plug for connection to a permanently installed receptacle outlet (also called a "multiplug adaptor").

Revise as follows:

~~**604.4 Multiplug adapters, Relocatable power taps and current taps.** Multiplug adapters, such as cube adapters, unfused plug strips or any other device not complying with NFPA 70 shall be prohibited. The construction and use of current taps and relocatable taps shall be in accordance with NFPA 70 and this code.~~

~~**604.4.1 Power tap design, Listing.** Relocatable power taps shall be of the polarized or grounded type, equipped with overcurrent protection, and shall be listed in accordance with UL 1363. Current taps shall be listed and labeled in accordance with UL 498A~~

~~**604.4.2 Power supply, Application and use.** Relocatable power taps and current taps shall be directly connected to a permanently installed receptacle.~~

Exceptions:

1. Where used in a meeting room in a Group B Occupancy, no more than five relocatable power taps shall be permitted to be connected together for temporary use to supply power to electronic equipment.
2. Current taps and relocatable power taps shall not be required to connect directly to a permanently installed receptacle outlet where used for 90 days or less for the purpose of testing the performance of such devices.

~~**604.4.3 Installation.** Relocatable power tap cords shall not extend through walls, ceilings, floors, under doors or floor coverings, or be subject to environmental or physical damage.~~

Add new text as follows:

~~**604.4.4 Maintenance.** Relocatable power taps and current taps shall be maintained in a safe condition without splices, deterioration or damage~~

~~**604.4.5 Grounding.** Relocatable power taps and current taps shall be grounded where serving grounded portable appliances.~~

Add new standard(s) follows:

UL

Underwriters Laboratories LLC
333 Pfingsten Road
Northbrook IL 60062

498A-08:

Current Taps and Adapters - with revisions thru June 10, 2016

Reason:

This is one of 17 proposals being submitted as a package relating to technical and organizational changes proposed for Chapter 6. While the Fire Code Committee will consider each proposal independently, the intent is for approval of all proposals in this package which have been submitted as a correlated set of companion code change proposals.

This proposal addresses the following:

1. Uses the correct industry terms for these devices - relocatable power taps and current taps - and provides definitions.
2. Adds the proper standard for current taps, UL 498A..
3. Removes the prescriptive construction requirements for relocatable power taps, which are already included in the required standard, UL 1363.
4. Permits the use of connecting multiple relocatable power taps together for temporary use in conference rooms with specific limitations. Expands the allowance of current taps and relocatable power taps to be used in temporary situations, with specific limitations, in accordance with the National Electrical Code, NFPA 70.
5. Adds maintenance and grounding requirements that are the same as the requirements for extension cords.

This proposal is submitted by the ICC Fire Code Action Committee (FCAC). The FCAC was established by the ICC Board of Directors to pursue opportunities to improve and enhance assigned International Codes with regard to fire safety and hazardous materials in new and existing buildings and facilities and the protection of life and property in wildland urban interface areas. In 2017 the Fire-CAC has held 3 open meetings. In addition, there were numerous conference calls, Regional Work Group and Task Group meetings for the current code development cycle, which included members of the committees as well as any interested parties, to discuss and debate the proposed changes. Related documentation and reports are posted on the FCAC website at: <https://www.iccsafe.org/codes-tech-support/cs/fire-code-action-committee-fcac/>

Cost Impact

The code change proposal will not increase or decrease the cost of construction .

Clarifies already existing requirements, and uses current terminology. Provides for more flexible use of relocatable power taps.

Analysis: A review of the standard proposed for inclusion in the code, UL 498A-08, with regard to the ICC criteria for referenced standards (Section 3.6 of CP#28) will be posted on the ICC website on or before April 2, 2018.

Internal ID: 410

F73-18

IFC: 604.4.1.1 (New), Chapter 80

Proponent: John Williams, Chair, representing Healthcare Committee (AHC@iccsafe.org); Michael O'Brian, Chair, representing FCAC (fcac@iccsafe.org)

2018 International Fire Code

Add new text as follows:

604.4.1.1 Listing in Group I-2 occupancies and ambulatory care facilities. . In Group I-2 occupancies and ambulatory care facilities, relocatable power taps shall be listed in accordance with UL 1363 except under the following conditions.

1. In Group I-2, Condition 2 occupancies, relocatable power taps providing power to patient care-related electrical equipment in the patient care vicinity as defined by NFPA 99 shall be listed in accordance with UL 1363A or UL 60601-1.
2. In Group I-2, Condition 1 facilities, in care recipient rooms using line-operated patientcare-related electrical equipment, relocatable power taps in the patient care vicinity as defined by NFPA 99 shall be listed in accordance with UL 1363A or UL 60601-1.
3. In ambulatory care facilities, relocatable power taps providing power to patient care-related electrical equipment in the patient care vicinity as defined by NFPA 99 shall be listed in accordance with UL 1363A or UL 60601-1.

Add new standard(s) follows:

UL

Underwriters Laboratories LLC
333 Pfingsten Road
Northbrook IL 60062

1363A-2014:

Standard for Relocatable Power Taps

60601-2003:

Medical Electrical Equipment, Part i: General Requirements for Safety

Reason:

Due to the potential for electrical shock to patients and care recipients the need for a higher standard for relocatable power taps within the patient care vicinity and resident rooms using line-operating patientcare related electrical equipment is needed (K920).

Patient care vicinity is defined in NFPA 99 as an area that is a 6'-0" space around a care recipient exam or treatment location.

This proposal is submitted by the ICC Fire Code Action Committee (FCAC) and the ICC Committee on Healthcare (CHC).

The FCAC was established by the ICC Board of Directors to pursue opportunities to improve and enhance assigned International Codes with regard to fire safety and hazardous materials in new and existing buildings and facilities and the protection of life and property in wildland urban interface areas. In 2017 the Fire-CAC has held 3 open meetings. In addition, there were numerous conference calls, Regional Work Group and Task Group meetings for the current code development cycle, which included members of the committees as well as any interested parties, to discuss and debate the proposed changes. Related documentation and reports are posted on the FCAC website at: <https://www.iccsafe.org/codes-tech-support/cs/fire-code-action-committee-fcac/>

The CHC was established by the ICC Board to evaluate and assess contemporary code issues relating to healthcare facilities. This is a joint effort between ICC and the American Society for Healthcare Engineering (ASHE), a subsidiary of the American Hospital Association, to eliminate duplication and conflicts in healthcare regulation. In 2017 the CHC held 2 open meetings and numerous conference calls, which included members of the committees as well as any interested parties, to discuss and debate the proposed changes. Information on the CHC, including: meeting agendas; minutes; reports; resource documents; presentations; and all other materials developed in conjunction with the CHC effort can be downloaded from the CHC website at: <https://www.iccsafe.org/codes-tech-support/cs/icc-committee-on-healthcare/>.

Cost Impact

The code change proposal will not increase or decrease the cost of construction .

This change is an operational change regarding the use of relocatable power taps and will not increase the cost of construction in the healthcare industry.

Analysis: A review of the standards proposed for inclusion in the code, UL 1363A-2014 and UL 60601-2003, with regard to the ICC criteria for referenced standards (Section 3.6 of CP#28) will be posted on the ICC website on or before April 2, 2018.

Internal ID: 696

F74-18

IFC: 604.5, 604.5.1

Proponent: Michael O'Brian, Chair, representing FCAC (fcac@iccsafe.org)

2018 International Fire Code

Revise as follows:

604.5 Extension cords. Extension cords ~~and flexible cords~~ shall not be a substitute for permanent wiring and shall be listed and labeled in accordance with UL 817. Extension cords and flexible cords shall not be affixed to structures, extended through walls, ceilings or floors, or under doors or floor coverings, nor shall such cords be subject to environmental damage or physical impact. Extension cords shall be used only with portable appliances. Extension cords marked for indoor use shall not be used outdoors.

604.5.1 ~~Power supply.~~ Application and use. Extension cords shall be plugged directly into an *approved* receptacle, relocatable power tap or multiplug adapter current tap, and, except for *approved* multiplug extension cords, shall serve only one portable appliance.

Reason:

This is one of 17 proposals being submitted as a package relating to technical and organizational changes proposed for Chapter 6. While the Fire Code Committee will consider each proposal independently, the intent is for approval of all proposals in this package which have been submitted as a correlated set of companion code change proposals.

The National Electrical Code (NFPA 70) permits in Article 400 the use of flexible cords for permanent wiring in a variety of conditions, including wiring of luminaires, elevators, cranes and hoists, connection of utilization equipment to facilitate frequent interchange, to prevent the transmission of noise or vibration. UL 817 is used for listing extension cords, but not for listing flexible cords.

The terms "relocatable power tap" and "current tap" are more current than the term "multiplug adapter".

This proposal is submitted by the ICC Fire Code Action Committee (FCAC). The FCAC was established by the ICC Board of Directors to pursue opportunities to improve and enhance assigned International Codes with regard to fire safety and hazardous materials in new and existing buildings and facilities and the protection of life and property in wildland urban interface areas. In 2017 the Fire-CAC has held 3 open meetings. In addition, there were numerous conference calls, Regional Work Group and Task Group meetings for the current code development cycle, which included members of the committees as well as any interested parties, to discuss and debate the proposed changes. Related documentation and reports are posted on the FCAC website at: <https://www.iccsafe.org/codes-tech-support/cs/fire-code-action-committee-fcac/>

Cost Impact

The code change proposal will not increase or decrease the cost of construction .

The requirements in NFPA 70 are not changed, which establish the requirements for use of flexible cords. This proposal removes a conflict with NFPA 70.

Internal ID: 411

F75-18

IFC: 604.9, 604.9.1

Proponent: Michael O'Brian, Chair, representing FCAC (fcac@iccsafe.org)

2018 International Fire Code

Revise as follows:

604.9 Temporary wiring. ~~Temporary~~ ~~The use of temporary~~ wiring for electrical power and lighting installations is ~~allowed for~~ shall not exceed a period ~~not to exceed of~~ 90 days. Temporary wiring methods shall meet the applicable provisions of NFPA 70.

Exception: Temporary wiring for electrical power and lighting installations ~~is allowed~~ complying with the applicable provisions of NFPA 70 is permitted during periods of construction, remodeling, repair or demolition of buildings, structures, equipment or similar activities.

604.9.1 Attachment to structures. Temporary wiring attached to a structure shall be ~~attached in an approved~~ manner protected from physical damage and supported on insulators spaced not more than 10 ft. (3.0 m) apart

Reason:

This is one of 17 proposals being submitted as a package relating to technical and organizational changes proposed for Chapter 6. While the Fire Code Committee will consider each proposal independently, the intent is for approval of all proposals in this package which have been submitted as a correlated set of companion code change proposals.

This proposal aligns the requirements for temporary wiring with NFPA 70, and provides specific criteria regarding the attachment of temporary wiring to structures.

This proposal is submitted by the ICC Fire Code Action Committee (FCAC). The FCAC was established by the ICC Board of Directors to pursue opportunities to improve and enhance assigned International Codes with regard to fire safety and hazardous materials in new and existing buildings and facilities and the protection of life and property in wildland urban interface areas. In 2017 the Fire-CAC has held 3 open meetings. In addition, there were numerous conference calls, Regional Work Group and Task Group meetings for the current code development cycle, which included members of the committees as well as any interested parties, to discuss and debate the proposed changes. Related documentation and reports are posted on the FCAC website at: <https://www.iccsafe.org/codes-tech-support/cs/fire-code-action-committee-fcac/>

Cost Impact

The code change proposal will not increase or decrease the cost of construction .

Clarifies existing requirements for temporary wiring and is will not affect construction cost.

Internal ID: 468

F76-18

IFC: 605.1.2, Chapter 80

Proponent: Jeffrey Shapiro, representing International Institute of Ammonia Refrigeration
(jeff.shapiro@intlcodeconsultants.com)

2018 International Fire Code

Revise as follows:

605.1.2 Ammonia refrigeration. Refrigeration systems using ammonia refrigerant and the buildings in which such systems are installed shall comply with IIAR-2 for system design and installation, IIAR 6 for maintenance and inspection, and IIAR-7 for operating procedures. Decommissioning of ammonia refrigeration systems shall comply with IIAR-8.

Update standard(s) as follows:

IIAR

International Institute of Ammonia
Refrigeration
1001 N. Fairfax Street, Suite 503
Alexandria VA 22314
US

IIAR - 2-2014:

Safe Design of Closed-circuit Ammonia ~~Refrigerating~~ Refrigeration Systems

IIAR - 8-2015:

Decommissioning of Closed-circuit Ammonia ~~Refrigerating~~ Refrigeration Systems

IIAR 6-2018:

Standard for Inspection, Testing, and Maintenance of Closed-Circuit Ammonia Refrigeration Systems

Reason:

IIAR 6 is a newly developed standard, being produced in accordance with ANSI requirements. It will provide comprehensive model regulations for maintenance and inspection of ammonia refrigeration systems and is part of a comprehensive set of IIAR standards for such systems that have been adopted by the IFC, IMC and other model codes. The first public comment period for this document has been completed, and it is anticipated that the document will be finished in time for adoption by the ICC membership in 2018.

Cost Impact

The code change proposal will not increase or decrease the cost of construction .

IIAR 6 is a maintenance and inspection standard for existing ammonia refrigeration systems.

Analysis: A review of the standard proposed for inclusion in the code, IIAR 6—2018, with regard to the ICC criteria for referenced standards (Section 3.6 of CP#28) will be posted on the ICC website on or before April 2, 2018.

Internal ID: 1511

F77-18

IFC: 605.1.2

Proponent: Jeffrey Shapiro, representing International Institute of Ammonia Refrigeration
(jeff.shapiro@intlcodeconsultants.com)

2018 International Fire Code

Revise as follows:

605.1.2 Ammonia refrigeration. Refrigeration systems using ammonia refrigerant and the buildings in which such systems are installed shall comply with IIAR – 2 for system design and installation and IIAR – 7 for operating procedures. Decommissioning of ammonia refrigeration systems shall comply with IIAR – 8.

Reason:

Installation requirements have been migrating out of IIAR 2 and into IIAR 4, "Installation of Closed-Circuit Ammonia Refrigeration Systems," which is referenced by the IMC since installation of systems is scoped to that code. This proposal corrects the reference to IIAR 2.

Cost Impact

The code change proposal will not increase or decrease the cost of construction .

Simply correlating with the scope of the referenced standard.

Internal ID: 578

F78-18

IFC: 605.1.2, Chapter 80

Proponent: Jeffrey Shapiro, representing International Institute of Ammonia Refrigeration
(jeff.shapiro@intlcodeconsultants.com)

2018 International Fire Code

Revise as follows:

605.1.2 Ammonia refrigeration. Refrigeration systems using ammonia refrigerant and the buildings in which such systems are installed shall comply with IIAR-2 for system design and installation and IIAR-7 for operating procedures. Decommissioning of ammonia refrigeration systems shall comply with IIAR 8, and engineering practices for existing ammonia refrigeration systems shall be in accordance with IIAR 9.

Add new standard(s) follows:

IIAR

International Institute of Ammonia
Refrigeration
1001 N. Fairfax Street, Suite 503
Alexandria VA 22314

IIAR 9-2018:

Standard for Recognized and Generally Accepted Good Engineering Practices (RAGAGEP) for Existing Closed-circuit Ammonia Refrigeration Systems

Reason:

IIAR 9 is a newly developed standard, being produced in accordance with ANSI requirements. It will provide comprehensive model regulations for minimum retroactive safety requirements applicable to ammonia refrigeration systems. It is part of a comprehensive set of IIAR standards for such systems that have been adopted by the IFC, IMC and other model codes. It is anticipated that the document will be finished in time for adoption by the ICC membership in 2018.

Cost Impact

The code change proposal will not increase or decrease the cost of construction .

The proposed standard does not affect construction. It applies to existing ammonia refrigeration systems.

Analysis: A review of the standard proposed for inclusion in the code, IIAR 9-2018, with regard to the ICC criteria for referenced standards (Section 3.6 of CP#28) will be posted on the ICC website on or before April 2, 2018.

Internal ID: 1901

F79-18 Part I

IFC: 202, (New), 605.8, 605.8.1, 605.8.1.1 (New), 605.8.1.2 (New), 605.17.1; IMC: [F]1106.5.1

Proponent: Connor Barbaree, ASHRAE, representing ASHRAE (cbarbaree@ashrae.org)

THIS IS A 2 PART CODE CHANGE PROPOSAL. PART I WILL BE HEARD THE IFC COMMITTEE, PART II WILL BE HEARD BY THE IMC COMMITTEE. PLEASE SEE THE TENTATIVE HEARING ORDERS FOR THE RESPECTIVE COMMITTEES.

2018 International Fire Code

CHAPTER 2 DEFINITIONS

SECTION 202 GENERAL DEFINITIONS

Add new definition as follows:

REFRIGERANT DETECTOR. A device that is capable of sensing the presence of refrigerant vapor.

CHAPTER 6 BUILDING SERVICES AND SYSTEMS

SECTION 605 MECHANICAL REFRIGERATION

[M] 605.1 Scope. Refrigeration systems shall be installed in accordance with the International Mechanical Code.

605.5 Access. Access to refrigeration systems having a refrigerant circuit containing more than 220 pounds (100 kg) of Group A1 or 30 pounds (14 kg) of any other group refrigerant shall be provided for the fire department at all times as required by the *fire code official*.

605.6 Testing of equipment. Refrigeration equipment and systems having a refrigerant circuit containing more than 220 pounds (100 kg) of Group A1 or 30 pounds (14 kg) of any other group refrigerant shall be subject to periodic testing in accordance with Section 605.6.1. Records of tests shall be maintained. Tests of emergency devices or systems required by this chapter shall be conducted by persons trained and qualified in refrigeration systems.

605.6.1 Periodic testing. The following emergency devices or systems shall be periodically tested in accordance with the manufacturer's instructions and as required by the *fire code official*.

1. Treatment and flaring systems.
2. Valves and appurtenances necessary to the operation of emergency refrigeration control boxes.
3. Fans and associated equipment intended to operate emergency ventilation systems.
4. Detection and alarm systems.

Revise as follows:

605.8 Refrigerant detection. Machinery rooms shall be provided with ~~a refrigerant detector~~ one or more refrigerant detectors capable of detecting the specific refrigerant(s) utilized in the machinery room, with an audible and visible alarm. Where ammonia is used as the refrigerant, detection shall comply with IIAR 2. For refrigerants other than ammonia, refrigerant detection shall comply with Section 605.8.1.

605.8.1 Refrigerants other than ammonia.

A detector, or a sampling tube that draws air to a detector, shall be provided at ~~an one or more approved location~~ locations where refrigerant from a leak is expected to accumulate. ~~The system shall be designed to initiate audible and visible alarms inside of and outside each entrance to the refrigerating machinery room and transmit a signal to an approved location where the concentration of refrigerant detected exceeds the lesser of the following:~~

1. ~~The corresponding TLV-TWA values shown in the International Mechanical Code for the refrigerant classification.~~
2. ~~Twenty five percent of the lower flammable limit (LFL).~~

~~Detection of a refrigerant concentration exceeding the upper detection limit or 25 percent of the lower flammable limit (LFL), whichever is lower, shall stop refrigerant equipment in the machinery room in accordance with Section 605.9.1.~~ detection, signaling and control circuits shall be supervised. The detection system shall be designed in

accordance with Sections 605.8.1.1 and 605.8.1.2.

Add new text as follows:

605.8.1.1 Low level response. The system shall be designed to perform the following actions when the concentration of refrigerant detected exceeds the smallest value of Occupational Exposure Limit (OEL) and does not exceed the smallest value of Refrigerant Concentration Level (RCL), as listed in the International Mechanical Code for any refrigerant utilized in the machinery room:

1. Initiate audible and visible alarms inside of and outside each entrance to the refrigerating machinery room and transmit a signal to an approved location.
2. The ventilation system shall provide a flow rate not less than the highest of the following values for any refrigerant utilized in the machinery room: for Group A1 and B1 refrigerants 100% of the normal ventilation quantity, and for Group A2L, A2, A3, B2L, B2, and B3 refrigerants, 50% of the emergency conditions quantity, as required by the International Mechanical Code.
3. After initiation of alarms and ventilation system, it is permissible to utilize automatic reset of alarms and ventilation system after the refrigerant concentration has reduced below the OEL and maintained below the OEL for a minimum of 15 minutes.

605.8.1.2 High level response. The system shall be designed to perform the following actions when the concentration of refrigerant detected exceeds the refrigerant concentration limit (RCL), or 25 percent of the lower flammable limit (LFL), or upper detection limit of the detector, whichever is lower, for any refrigerant utilized in the machinery room:

1. Initiate audible and visible alarms inside of and outside each entrance to the refrigerating machinery room and transmit a signal to an approved location.
2. The ventilation system shall provide a flow rate not less than 100% of the emergency conditions quantity required by the International Mechanical Code.
3. For Group A2L, A2, A3, B2L, B2, and B3 refrigerants, stop refrigerant equipment in the machinery room in accordance with Section 605.9.1.
4. After initiation, alarms and ventilation system shall continue until manually reset at a location within the machinery room.

Delete without substitution:

605.17.1 Refrigerant detection system. ~~The machinery room shall be provided with a refrigerant detection system. The refrigerant detection system shall be in accordance with Section 605.8 and all of the following:~~

- ~~1. The detectors shall activate at or below a refrigerant concentration of 25 percent of the LFL.~~
- ~~2. Upon activation, the detection system shall activate the emergency ventilation system in Section 605.17.3.~~
- ~~3. The detection, signaling and control circuits shall be supervised.~~

2018 International Mechanical Code

Delete and substitute as follows:

[F] 1106.5.1 Refrigerant detection system. ~~The machinery room shall be provided with a refrigerant detection system. The refrigerant detection system shall be in accordance with Section 605.8 of the International Fire Code and all of the following:~~

- ~~1. The detectors shall activate at or below a refrigerant concentration of 25% of the LFL.~~
- ~~2. Upon activation, the detection system shall activate the emergency ventilation system required by Section 1106.5.2.~~
- ~~3. The detection, signaling and control circuits shall be supervised.~~

[F] 1106.5.1 Refrigerant detection system. The machinery room shall be provided with a refrigerant detection system. The refrigerant detection system shall be in accordance with Section 605.8 of the International Fire Code.

F79-18 Part II

IFC: [M]605.16, [M]605.17, [M]605.17.2, TABLE [M] 605.17.2, [M]605.17.3; IMC: 202(New), 1103.1, TABLE 1103.1, 1106.4, 1106.5.2, TABLE 1106.5.2

Proponent: Connor Barbaree, ASHRAE, representing ASHRAE (cbarbaree@ashrae.org)

2018 International Fire Code

Revise as follows:

[M] 605.16 Electrical equipment. Where *refrigerant* of Groups A2L, A2, A3, B2L, B2 and B3, as defined in the International Mechanical Code, are used, refrigeration machinery rooms shall conform to the Class I, Division 2 hazardous location classification requirements of NFPA 70.

Exceptions:

1. Ammonia machinery rooms that are provided with ventilation in accordance with Section 1106.3 of the International Mechanical Code.
2. Machinery rooms for systems containing Group A2L *refrigerants* that are provided with ventilation in accordance with Section 605.17, or Group B2L refrigerants that are provided with ventilation in accordance with Section 605.17. Sections 605.12.3 and Section 1106.3 of the International Mechanical Code.

[M] 605.17 Special requirements for Group A2L refrigerant machinery rooms. Machinery rooms with systems containing Group A2L refrigerants shall comply with Sections 605.17.1 through 605.17.3. Section 1106.4 of the International Mechanical Code.

Exception: Machinery rooms conforming to the Class 1, Division 2 hazardous location classification requirements of NFPA 70.

Delete without substitution:

~~**[M] 605.17.2 Emergency ventilation system.** An emergency ventilation system shall be provided at the minimum exhaust rate specified in ASHRAE 15 or Table 605.17.2. Shut down of the emergency ventilation system shall be by manual means.~~

**TABLE [M] 605.17.2
MINIMUM EXHAUST RATE**

REFRIGERANT	Q (m ³ /sec)	Q (cfm)
R32	15.4	32,600
R143a	13.6	28,700
R444A	6.46	13,700
R444B	10.6	22,400
R445A	7.83	16,600
R446A	23.9	50,700
R447A	23.8	50,400
R451A	7.04	15,000
R451B	7.05	15,000
R1234yf	7.80	16,600
R1234ze(E)	5.92	12,600

~~**[M] 605.17.3 Emergency ventilation system discharge.** The point of discharge to the atmosphere shall be located outside of the structure at not less than 15 feet (4572 mm) above the adjoining grade level and not less than 20 feet (6096 mm) from any window, ventilation opening or exit.~~

2018 International Mechanical Code

CHAPTER 2 DEFINITIONS

SECTION 202 GENERAL DEFINITIONS

Delete and substitute as follows:

~~**FLAMMABILITY CLASSIFICATION.** Refrigerants shall be assigned to one of the three classes—1, 2 or 3—in accordance with ASHRAE 34. For Classes 2 and 3, the heat of *combustion* shall be calculated assuming that *combustion* products are in the gas phase and in their most stable state.~~

~~**Class 1.** Refrigerants that do not show flame propagation when tested in air at 14.7 psia (101 kPa) and 140°F (60°C).~~

~~**Class 2.** Refrigerants having a lower flammability limit (LFL) of more than 0.00625 pound per cubic foot (0.10 kg/m³) at 140°F (60°C) and 14.7 psia (101 kPa) and a heat of combustion of less than 8169 Btu/lb (19 000 kJ/kg).~~

~~**Class 3.** Refrigerants that are highly flammable, having a LFL of less than or equal to 0.00625 pound per cubic foot (0.10 kg/m³) at 140°F (60°C) and 14.7 psia (101 kPa) or a heat of combustion greater than or equal to 8169 Btu/lb (19 000 kJ/kg).~~

~~**FLAMMABILITY CLASSIFICATION (REFRIGERANT).** The alphabetical/numerical designation used to identify the flammability of refrigerants. Class 1 indicates a refrigerant with no flame propagation. Class 2L indicates a refrigerant with lower flammability and lower burning velocity. Class 2 indicates a refrigerant with lower flammability. Class 3 indicates a refrigerant with higher flammability.~~

Add new definition as follows:

~~**REFRIGERANT CONCENTRATION LIMIT (REFRIGERANT) (RCL)** The refrigerant concentration limit, in air, intended to reduce the risks of acute toxicity, asphyxiation, and flammability hazards in normally occupied, enclosed spaces.~~

Delete and substitute as follows:

~~**REFRIGERANT SAFETY CLASSIFICATIONS.** Groupings that indicate the toxicity and flammability classes in accordance with Section 1103.1. The classification group is made up of a letter (A or B) that indicates the toxicity class, followed by a number (1, 2 or 3) that indicates the flammability class. Refrigerant blends are similarly classified, based on the compositions at their worst cases of fractionation, as separately determined for toxicity and flammability. In some cases, the worst case of fractionation is the original formulation.~~

~~**Flammability.** See “Flammability classification.”~~

~~**Toxicity.** See “Toxicity classification.”~~

REFRIGERANT SAFETY GROUP CLASSIFICATION. The alphabetical/numerical designation that indicates both toxicity and flammability classifications of refrigerants.

Toxicity. See "Toxicity classification (Refrigerant)."

Flammability. See "Flammability classification (Refrigerant)."

~~**TOXICITY CLASSIFICATION.** Refrigerants shall be classified for toxicity in one of two classes in accordance with ASHRAE 34:~~

~~**Class A.** Refrigerants that have an occupational exposure limit (OEL) of 400 parts per million (ppm) or greater.~~

~~**Class B.** Refrigerants that have an OEL of less than 400 ppm.~~

TOXICITY CLASSIFICATION (REFRIGERANT). An alphabetical designation used to identify the toxicity of refrigerants. Class A indicates a refrigerant with lower toxicity. Class B indicates a refrigerant with higher toxicity.

CHAPTER 11 REFRIGERATION

SECTION 1103 REFRIGERATION SYSTEM CLASSIFICATION

Revise as follows:

1103.1 Refrigerant classification. Refrigerants shall be classified in accordance with ASHRAE 34 as listed in Table 1103.1. Each refrigerant shall be assigned to one of the following refrigerant safety group classifications: A1, A2L, A2, A3, B1, B2L, B2, or B3. For refrigerants that do not have values in Table 1103.1, the safety group, RCL value, and OEL value shall be determined in accordance with ASHRAE 34 and approved by the code official.

TABLE 1103.1

REFRIGERANT CLASSIFICATION, AMOUNT AND OEL

CHEMICAL REFRIGERANT	FORMULA	CHEMICAL NAME OF BLEND	REFRIGERANT SAFETY GROUP CLASSIFICATION	AMOUNT OF REFRIGERANT PER OCCUPIED SPACE				[F] DEGREES OF HAZARD ^a
				RCL			OEL ^c	
				lb per 1,000 ft ³ Pounds per 1,000 cubic feet	ppm	g/m ³	ppm	
R-11 ^d	CCl ₃ F	trichlorofluoromethane	A1	0.39	1,100	6.2	1,000	2-0-0 ^b
R-12 ^d	CCl ₂ F ₂	dichlorodifluoromethane	A1	5.6	18,000	90	1,000	2-0-0 ^b
R-13 ^d	CCIF ₃	chlorotrifluoromethane	A1	—	—	—	1,000	2-0-0 ^b
R-13B1 ^d	CBrF ₃	bromotrifluoromethane	A1	—	—	—	1,000	2-0-0 ^b
R-14	CF ₄	tetrafluoromethane (carbon tetrafluoride)	A1	25	110,000	400	1,000	2-0-0 ^b
R-22	CHClF ₂	chlorodifluoromethane	A1	13	59,000	210	1,000	2-0-0 ^b
R-23	CHF ₃	trifluoromethane (fluoroform)	A1	7.3	41,000	120	1,000	2-0-0 ^b
R-30	CH ₂ Cl ₂	dichloromethane (methylene chloride)	B1	—	—	—	—	—
R-32	CH ₂ F ₂	difluoromethane (methylene fluoride)	A2L, A2 ^f	4.8	36,000	77	1,000	1-4-0
R-40	CH ₃ Cl	chloromethane (methyl chloride)	B2	—	—	—	—	—
R-50	CH ₄	methane	A3	—	—	—	1,000	—
R-113 ^d	CCl ₂ CClF ₂	1,1,2-trichloro-1,1,2-trifluoroethane	A1	1.2	2,600	20	1,000	2-0-0 ^b
R-114 ^{ff}	CClF ₂ CClF ₂	1,2-dichloro-1,1,2,2-tetrafluoroethane	A1	8.7	20,000	140	1,000	2-0-0 ^b
R-115	CClF ₂ CF ₃	chloropentafluoroethane	A1	47	120,000	760	1,000	—
R-116	CF ₃ CF ₃	hexafluoroethane	A1	34	97,000	550	1,000	1-0-0
R-123	CHCl ₂ CF ₃	2,2-dichloro-1,1,1-trifluoroethane	B1	3.5	9,100	57	50	2-0-0 ^b
R-124	CHClFCF ₃	2-chloro-1,1,1,2-tetrafluoroethane	A1	3.5	10,000	56	1,000	2-0-0 ^b
R-125	CHF ₂ CF ₃	pentafluoroethane	A1	23	75,000	370	1,000	2-0-0 ^b
R-134a	CH ₂ FCF ₃	1,1,1,2-tetrafluoroethane	A1	13	50,000	210	1,000	2-0-0 ^b
R-141b	CH ₃ CCl ₂ F	1,1-dichloro-1-fluoroethane	—	0.78	2,600	12	500	2-1-0
R-142b	CH ₃ CClF ₂	1-chloro-1, 1-difluoroethane	A2	5.1	20,000	83	1,000	2-4-0
R-143a	CH ₃ CF ₃	1,1,1-trifluoroethane	A2L, A2 ^f	4.5	21,000	70	1,000	2-0-0 ^b
R-152a	CH ₃ CHF ₂	1,1-difluoroethane	A2	2.0	12,000	32	1,000	1-4-0
R-170	CH ₃ CH ₃	ethane	A3	0.54	7,000	8.7	1,000	2-4-0
R-E170	CH ₃ OCH ₃	Methoxymethane (dimethyl ether)	A3	1.0	8,500	16	1,000	—
R-218	CF ₃ CF ₂ CF ₃	octafluoropropane	A1	43	90,000	690	1,000	2-0-0 ^b
R-227ea	CF ₃ CHFCF ₃	1,1,1,2,3,3,3-heptafluoropropane	A1	36	84,000	580	1,000	—
R-236fa	CF ₃ CH ₂ CF ₃	1,1,1,3,3,3-hexafluoropropane	A1	21	55,000	340	1,000	2-0-0 ^b
R-245fa	CHF ₂ CH ₂ CF ₃	1,1,1,3,3-pentafluoropropane	B1	12	34,000	190	300	2-0-0 ^b
R-290	CH ₃ CH ₂ CH ₃	propane	A3	0.56	5,300	9.5	1,000	2-4-0
R-C318	-(CF ₂) ₄ -	octafluorocyclobutane	A1	41	80,000	660	1,000	—
R-400 ^d	zeotrope	R-12/114 (50.0/50.0)	A1	10	28,000	160	1,000	2-0-0 ^b
R-400 ^{ff}	zeotrope	R-12/114 (60.0/40.0)	A1	11	30,000	170	1,000	—
R-401A	zeotrope	R-22/152a/124 (53.0/13.0/34.0)	A1	6.6	27,000	110	1,000	2-0-0 ^b
R-401B	zeotrope	R-22/152a/124 (61.0/11.0/28.0)	A1	7.2	30,000	120	1,000	2-0-0 ^b
R-401C	zeotrope	R-22/152a/124 (33.0/15.0/52.0)	A1	5.2	20,000	84	1,000	2-0-0 ^b
R-402A	zeotrope	R-125/290/22 (60.0/2.0/38.0)	A1	17	66,000	270	1,000	2-0-0 ^b
R-402B	zeotrope	R-125/290/22 (38.0/2.0/60.0)	A1	15	63,000	240	1,000	2-0-0 ^b
R-403A	zeotrope	R-290/22/218 (5.0/75.0/20.0)	A2	7.6	33,000	120	1,000	2-0-0 ^b
R-403B	zeotrope	R-290/22/218 (5.0/56.0/39.0)	A1	18	70,000	290	1,000	2-0-0 ^b

R-404A	zeetrope	R-125/143a/134a (44.0/52.0/4.0)	A1	31	130,000	500	1,000	2-0-0 ^b
R-405A	zeetrope	R-22/152a/142b/C 318 (45.0/7.0/5.5/2.5)	—	16	57,000	260	1,000	—
R-406A	zeetrope	R-22/600a/142b (55.0/4.0/41.0)	A2	4.7	21,000	25	1,000	—
R-407A	zeetrope	R-32/125/134a (20.0/40.0/40.0)	A1	19	83,000	300	1,000	2-0-0 ^b
R-407B	zeetrope	R-32/125/134a (10.0/70.0/20.0)	A1	21	79,000	330	1,000	2-0-0 ^b
R-407C	zeetrope	R-32/125/134a (23.0/25.0/52.0)	A1	18	81,000	290	1,000	2-0-0 ^b
R-407D	zeetrope	R-32/125/134a (15.0/15.0/70.0)	A1	16	68,000	250	1,000	2-0-0 ^b
R-407E	zeetrope	R-32/125/134a (25.0/15.0/60.0)	A1	17	80,000	280	1,000	2-0-0 ^b
R-407F	zeetrope	R-32/125/134a (30.0/30.0/40.0)	A1	20	95,000	320	1,000	—
R-408A	zeetrope	R-125/143a/22 (7.0/46.0/47.0)	A1	21	95,000	340	1,000	2-0-0 ^b
R-409A	zeetrope	R-22/124/142b (60.0/25.0/15.0)	A1	7.1	29,000	110	1,000	2-0-0 ^b
R-409B	zeetrope	R-22/124/142b (65.0/25.0/10.0)	A1	7.3	30,000	120	1,000	2-0-0 ^b
R-410A	zeetrope	R-32/125 (50.0/50.0)	A1	26	140,000	420	1,000	2-0-0 ^b
R-410B	zeetrope	R-32/125 (45.0/55.0)	A1	27	140,000	430	1,000	2-0-0 ^b
R-411A	zeetrope	R-127/22/152a (1.5/87.5/11.0)	A2	2.9	14,000	46	990	—
R-411B	zeetrope	R-1270/22/152a (3.0/94.0/3.0)	A2	2.8	13,000	45	980	—
R-412A	zeetrope	R-22/218/142b (70.0/5.0/25.0)	A2	5.1	22,000	82	1,000	—
R-413A	zeetrope	R-218/134a/600a (9.0/88.0/3.0)	A2	5.8	22,000	94	1,000	—
R-414A	zeetrope	R-22/124/600a/142b (51.0/28.5/4.0/16.5)	A1	6.4	26,000	100	1,000	—
R-414B	zeetrope	R-22/124/600a/142b (50.0/39.0/1.5/9.5)	A1	6.0	23,000	95	1,000	—
R-415A	zeetrope	R-22/152a (82.0/18.0)	A2	2.9	14,000	47	1,000	—
R-415B	zeetrope	R-22/152a (25.0/75.0)	A2	2.1	12,000	34	1,000	—
R-416A	zeetrope	R-134a/124/600 (59.0/39.5/1.5)	A1	3.9	14,000	62	1,000	2-0-0 ^b
R-417A	zeetrope	R-125/134a/600 (46.6/50.0/3.4)	A1	3.5	13,000	56	1,000	2-0-0 ^b
R-417B	zeetrope	R-125/134a/600 (79.0/18.3/2.7)	A1	4.3	15,000	70	1,000	—
R-417C	zeetrope	R-125/134a/600 (19.5/78.8/1.7)	A1	5.4	21,000	87	1,000	—
R-418A	zeetrope	R-290/22/152a (1.5/96.0/2.5)	A2	4.8	22,000	77	1,000	—
R-419A	zeetrope	R-125/134a/E170 (77.0/19.0/4.0)	A2	4.2	15,000	67	1,000	—
R-419B	zeetrope	R-125/134a/E170 (48.5/48.0/3.5)	A2	4.6	17,000	74	1,000	—
R-420A	zeetrope	R-134a/142b (88.0/12.0)	A1	12	45,000	190	1,000	2-0-0 ^b
R-421A	zeetrope	R-125/134a (58.0/42.0)	A1	17	61,000	280	1,000	2-0-0 ^b
R-421B	zeetrope	R-125/134a (85.0/15.0)	A1	21	69,000	330	1,000	2-0-0 ^b
R-422A	zeetrope	R-125/134a/600a (85.1/11.5/3.4)	A1	18	63,000	290	1,000	2-0-0 ^b
R-422B	zeetrope	R-125/134a/600a (55.0/42.0/3.0)	A1	16	56,000	250	1,000	2-0-0 ^b
R-422C	zeetrope	R-125/134a/600a (82.0/15.0/3.0)	A1	18	62,000	290	1,000	2-0-0 ^b
R-422D	zeetrope	R-125/134a/600a (65.1/31.5/3.4)	A1	16	58,000	260	1,000	2-0-0 ^b
R-422E	zeetrope	R-125/134a/600a (58.0/39.3/2.7)	A1	16	57,000	260	1,000	—
R-423A	zeetrope	R-134a/227ea (52.5/47.5)	A1	19	59,000	310	1,000	2-0-0 ^c
R-424A	zeetrope	R-125/134a/600a/600/601a (50.5/47.0/0.9/1.0/0.6)	A1	6.2	23,000	100	970	2-0-0 ^b
R-425A	zeetrope	R-32/134a/227ea (18.5/69.5/12.0)	A1	16	72,000	260	1,000	2-0-0 ^b
R-426A	zeetrope	R-125/134a/600a/601a (5.1/93.0/1.3/0.6)	A1	5.2	20,000	83	990	—

R-427A	zeotrope	R-32/125/143a/134a (15.0/25.0/10.0/50.0)	A1	18	79,000	290	1,000	2-1-0
R-428A	zeotrope	R-125/143a/290/600a (77.5/20.0/0.6/1.9)	A1	23	83,000	370	1,000	—
R-429A	zeotrope	R-E170/152a/600a (60.0/10.0/30.0)	A3	0.81	6,300	13	1,000	—
R-430A	zeotrope	R-152a/600a (76.0/24.0)	A3	1.3	8,000	21	1,000	—
R-431A	zeotrope	R-290/152a (71.0/29.0)	A3	0.69	5,500	11	1,000	—
R-432A	zeotrope	R-1270/E170 (80.0/20.0)	A3	0.13	1,200	2.1	700	—
R-433A	zeotrope	R-1270/290 (30.0/70.0)	A3	0.34	3,100	5.5	880	—
R-433B	zeotrope	R-1270/290 (5.0-95.0)	A3	0.51	4,500	8.1	950	—
R-433C	zeotrope	R-1270/290 (25.0-75.0)	A3	0.41	3,600	6.6	790	—
R-434A	zeotrope	R-125/143a/600a (63.2/18.0/16.0/2.8)	A1	20	73,000	320	1,000	—
R-435A	zeotrope	R-E170/152a (80.0/20.0)	A3	1.1	8,500	17	1,000	—
R-436A	zeotrope	R-290/600a (56.0/44.0)	A3	0.50	4,000	8.1	1,000	—
R-436B	zeotrope	R-290/600a (52.0/48.0)	A3	0.51	4,000	8.1	1,000	—
R-437A	zeotrope	R-125/134a/600/601 (19.5/78.5/1.4/0.6)	A1	5.0	19,000	82	990	—
R-438A	zeotrope	R-32/125/134a/600/601a (8.5/45.0/44.2/1.7/0.6)	A1	4.9	20,000	79	990	—
R-439A	zeotrope	R-32/125/600a (50.0/47.0/3.0)	A2	4.7	26,000	76	990	—
R-440A	zeotrope	R-290/134a/152a (0.6/1.6/97.8)	A2	1.9	12,000	31	1,000	—
R-441A	zeotrope	R-170/290/600a/600 (3.1/54.8/6.0/36.1)	A3	0.39	3,200	6.3	1,000	—
R-442A	zeotrope	R-32/125/134a/152a/227ea (31.0/31.0/30.0/3.0/5.0)	A1	21	100,000	330	1,000	—
R-443A	zeotrope	R-1270/290/600a (55.0/40.0/5.0)	A3	0.19	1,700	3.1	580	—
R-444A	zeotrope	R-32/152a/1234ze(E) (12.0/5.0/83.0)	A2L A2 ^f	5.1	21,000	81	850	—
R-444B	zeotrope	R-32/152a/1234ze(E) (41.5/10.0/48.5)	A2L A2 ^f	4.3	23,000	69	890	—
R-445A	zeotrope	R-744/134a/1234ze(E) (6.0/9.0/85.0)	A2L A2 ^f	4.2	16,000	67	930	—
R-446A	zeotrope	R-32/1234ze(E)/600 (68.0/29.0/3.0)	A2L A2 ^f	2.5	16,000	39	960	—
R-447A	zeotrope	R-32/125/1234ze(E) (68.0/3.5/28.5)	A2L A2 ^f	2.6	16,000	42	900	—
R-448A	zeotrope	R-32/125/1234yf/134a/1234ze(E) (26.0/26.0/20.0/21.0/7.0)	A1	24	110,000	390	890	—
R-449A	zeotrope	R-32/125/1234yf/134a (24.3/24.7/25.3/25.7)	A1	23	100,000	370	830	—
R-450A	zeotrope	R-134a/1234ze(E) (42.0/58.0)	A1	20	72,000	320	880	—
R-451A	zeotrope	R-1234yf/134a (89.8/10.2)	A2L A2 ^f	5.3	18,000	81	520	—
R-451B	zeotrope	R-1234yf/134a (88.8/11.2)	A2L A2 ^f	5.3	18,000	81	530	—
R-452A	zeotrope	R-32/125/1234yf (11.0/59.0/30.0)	A1	27	100,000	440	780	—
R-500 ^e	azeotrope	R-12/152a (73.8/26.2)	A1	7.6	30,000	120	1,000	2-0-0 ^h
R-501 ^d	azeotrope	R-22/12 (75.0/25.0)	A1	13	54,000	210	1,000	—
R-502 ^e	azeotrope	R-22/115 (48.8/51.2)	A1	21	73,000	330	1,000	2-0-0 ^h
R-503 ^e	azeotrope	R-23/13 (40.1/59.9)	—	—	—	—	1,000	2-0-0 ^h
R-504 ^d	azeotrope	R-32/115 (48.2/51.8)	—	28	140,000	450	1,000	—
R-507A	azeotrope	R-125/143a (50.0/50.0)	A1	32	130,000	520	1,000	2-0-0 ^h
R-508A	azeotrope	R-23/116 (39.0/61.0)	A1	14	55,000	220	1,000	2-0-0 ^h
R-508B	azeotrope	R-23/116 (46.0/54.0)	A1	13	52,000	200	1,000	2-0-0 ^h
R-509A	azeotrope	R-22/218 (44.0/56.0)	A1	24	75,000	390	1,000	2-0-0 ^h
R-510A	azeotrope	R-E170/600a (88.0/12.0)	A3	0.87	7,300	14	1,000	—
R-511A	azeotrope	R-290/E170 (95.0/5.0)	A3	0.59	5,300	9.5	1,000	—
R-512A	azeotrope	R-134a/152a (5.0/95.0)	A2	1.9	11,000	31	1,000	—
R-513A	azeotrope	R-1234yf/134a (56.0/44.0)	A1	20	72,000	320	650	—
R-600	CH ₃ CH ₂ CH ₂ CH ₃	butane	A3	0.15	1,000	2.4	1,000	1-4-0
R-600a	CH(CH ₃) ₂ CH ₃	2-methylpropane (isobutane)	A3	0.59	4,000	9.6	1,000	2-4-0

R-601	$\text{CH}_3\text{CH}_2\text{CH}_2\text{CH}_2\text{CH}_3$	pentane	A3	0.18	1,000	2.9	600	—
R-601a	$(\text{CH}_3)_2\text{CHCH}_2\text{CH}_3$	2-methylbutane (isopentane)	A3	0.18	1,000	2.9	600	—
R-610	ethoxyethane (ethyl ether)	$\text{CH}_3\text{CH}_2\text{OCH}_2\text{CH}_3$	—	—	—	—	400	—
R-611	methyl formate	HCOOCH_3	B2	—	—	—	100	—
R-717	NH_3	ammonia	B2L, B2 ^f	0.014	320	0.22	25	3-3-0 ^c
R-718	H_2O	water	A1	—	—	—	—	0-0-0
R-744	CO_2	carbon dioxide	A1	4.5	40,000	72	5,000	2-0-0 ^b
R-1150	$\text{CH}_2=\text{CH}_2$	ethene (ethylene)	A3	—	—	—	200	1-4-2
R-1233zd(E)	$\text{CF}_3\text{CH}=\text{CHCl}$	trans-1-chloro-3,3,3-trifluoro-1-propene	A1	5.3	16,000	85	800	—
R-1234yf	$\text{CF}_3\text{CF}=\text{CH}_2$	2,3,3,3-tetrafluoro-1 propene	A2L, A2 ^f	4.7	16,000	75	500	—
R-1234ze(E)	$\text{CF}_3\text{CH}=\text{CHF}$	trans-1,3,3,3-tetrafluoro-1-propene	A2L, A2 ^f	4.7	16,000	75	800	—
R-1270	$\text{CH}_3\text{CH}=\text{CH}_2$	Propene (propylene)	A3	0.1	1,000	1.7	500	1-4-1

For SI: 1 pound = 0.454 kg, 1 cubic foot = 0.0283m³

- a. Degrees of hazard are for health, fire, and reactivity, respectively, in accordance with NFPA 704.
- b. Reduction to 1-0-0 is allowed if analysis satisfactory to the code official shows that the maximum concentration for a rupture or full loss of refrigerant charge would not exceed the IDLH, considering both the refrigerant quantity and room volume.
- c. For installations that are entirely outdoors, use 3-1-0.
- d. Class I ozone depleting substance; prohibited for new installations.
- e. Occupational Exposure Limit based on the OSHA PEL, ACGIH TLV-TWA, the TERA WEEL or consistent value on a time-weighted average (TWA) basis (unless noted C for ceiling) for an 8 hr/d and 40 hr/wk.
- f. ~~The ASHRAE Standard 34 flammability classification for this refrigerant is 2L, which is a subclass of Class 2.~~

1106.4 Flammable refrigerants. Where refrigerants of Groups A2L, A2, A3, B2L, B2 and B3 are used in one or more refrigerating systems, the *machinery room* shall conform to the Class 1, Division 2, *hazardous location* classification requirements of NFPA 70.

Exceptions:

1. Ammonia *machinery rooms* that are provided with *ventilation* in accordance with Section 1106.3.
2. Machinery rooms for systems containing in which the refrigerating system(s) that contain(s) flammable refrigerants utilize only Group A2L refrigerants that refrigerant(s), and are in accordance with Section 1106.5.

1106.5.2 Emergency ventilation system. An emergency ventilation system shall be provided at the minimum exhaust rate specified in ASHRAE ~~15 or Table 1106.5.2-15~~. Shutdown of the emergency ventilation system shall be by manual means.

Delete without substitution:

**TABLE 1106.5.2
MINIMUM EXHAUST RATES**

REFRIGERANT	Q(m/sec)	Q(cfm)
R32	15.4	32,600
R143	13.6	28,700
R444A	6.46	13,700
R444B	10.6	22,400
R445A	7.83	16,600
R446A	23.9	50,700
R447A	23.8	50,400
R451A	7.04	15,000
R451B	7.05	15,000
R1234yf	7.80	16,600
R1234ze(E)	5.92	12,600

Reason:

The proposed code changes include technical content based on ASHRAE Standard 34-2016 with Addendum G and ASHRAE Standard 15-2016 with Addendum H. The revisions in these two ASHRAE addenda are dependent and must be correlated as shown in this code change proposal. Upon publication, these addenda will be incorporated into the 2019 editions of ASHRAE 34 and ASHRAE 15.

There was a considerable amount of industry research into the use of flammable refrigerants that occurred in 2016 and 2017, following the announcement in June 2016 of a collaborative research effort between ASHRAE, AHRI, and US DOE. ASHRAE SSPC15 relied upon this body of knowledge, extended upon prior ASHRAE research from 2012, in drafting the addenda to the 2016 edition of Standard 15.

The refrigerant safety group classification is an alphabetical/numerical designation that is used to identify both the toxicity and flammability classifications of a given refrigerant. There are two new safety group classifications added to ASHRAE 34: A2L and B2L. Previously 2L was a sub-class of class 2 as an interim measure to implement changes to refrigerant flammability classification into ASHRAE 34 prior to making associated changes to a future edition of ASHRAE 15; but now 2L is a separate class and safety requirements must be revised to distinguish between class 2 and class 2L.

The current definitions of “flammability classification” and “toxicity classification” are improper since both contain mandatory code requirements. The definitions should only define the term, not contain code requirements with the use of the word “shall.” The current definition of refrigerant safety classifications is incorrect due to revisions to ASHRAE 34. The attempt to define the technical requirements of flammability are not correct. ASHRAE 34 goes into extensive requirements as to how to test and classify a refrigerant regarding flammability. The code should leave the technical requirements to ASHRAE 34 which is accomplished in Section 1103.1. The definition only has to identify the meanings of the classification categories. These terms used are found in the body of ASHRAE 34. The addition of “refrigerant” to the term “flammability classification” and “toxicity classification” clarify that the definitions only apply to refrigerants. Flammability and toxicity are terms also used in the ventilation sections of the code. These definitions do not apply to the use of those terms in Chapter 5.

Bibliography:

(AHRI) Final Report - AHRI 8005 "Risk Assessment of Class 2L Refrigerants in Chiller Systems", prepared by Bill Goetzler, Matt Guernsey, & Collin Weber (July 2013).

<http://www.ahrinet.org/Resources/Research.aspx>

(ASHRAE 2012) ASHRAE Research Project TRP-1448, "Final Report: Ventilation Requirements for Refrigerating Machinery Rooms", July 2012.

(ASHRAE 2016a) ASHRAE Standard 15-2016 "Safety Standard for Refrigeration Systems" (2016).

(ASHRAE 2016b) ASHRAE Standard 34-2016 "Designation and Safety Classification of Refrigerants" (2016).

(Papas et. al. 2016) Paul Papas, Shiling Zhang, Hai Jiang, Parmesh Verma, Ivan Rydkin, Richard Lord & Larry Burns (2016) Computational fluid dynamics modeling of flammable refrigerant leaks inside machine rooms: Evaluation of ventilation mitigation requirements, Science and Technology for the Built Environment, 22:4, 463-471, DOI:10.1080/23744731.2016.1163240

Cost Impact

The code change proposal will not increase or decrease the cost of construction .

This code change proposal addresses a new safety group of refrigerants, with no precedent on the construction costs.

Internal ID: 3460

F80-18

IFC: 605.10

Proponent: Jeffrey Shapiro, representing International Institute of Ammonia Refrigeration
(jeff.shapiro@intlcodeconsultants.com)

2018 International Fire Code

Revise as follows:

605.10 Emergency pressure control system. Permanently installed refrigeration systems in machinery rooms containing more than 6.6 pounds (3 kg) of flammable, toxic or highly toxic refrigerant or ammonia shall be provided with an emergency pressure control system in accordance with Sections 605.10.1 and 605.10.2.

Reason:

The original concept of emergency pressure control systems (EPCS) was as a substitute for cross-over valves in manual emergency control boxes. Emergency control boxes were previously required, only by the UFC, with an expectation that ammonia could be transferred to another pressure zone or released to a water tank, treatment system or atmosphere to reduce system pressure in the event of a building fire that exposed the system to high temperatures. Whatever risk may occur is limited to large equipment that would be found in a machinery room, and this is recognized by the IMC, which limits EPCS requirements to machinery rooms in Section 1105.9 (Section 1105 is machinery rooms). This proposal correlates the IFC requirement with the IMC and appropriately recognizes that the risk of a major fire exposure to outdoor ammonia refrigeration equipment isn't sufficient to warrant the need for an EPCS. Such systems are already provided with normal operation pressure limits, overpressure sensors on compressors to stop compressors in the event of continued overpressure, and relief vents to maintain systems in a safe operating pressure range, and the EPCS is an unnecessary fourth-level safety feature for outdoor systems.

Cost Impact

The code change proposal will decrease the cost of construction .

Additional requirement to provide EPCS for outdoor equipment, and associated cost, would no longer be required.

Internal ID: 2104

F81-18

IFC: 605.12.2, 605.12.2.1 (New), 605.12.4

Proponent: Julius Ballanco, JB Engineering and Code Consulting, P.C., representing Daikin US (JBEngineer@aol.com)

2018 International Fire Code

Revise as follows:

605.12.2 Flammable refrigerants. Systems containing more than 6.6 pounds (3 kg) of ~~flammable Group A2, A3, B2, or B3~~ refrigerants having a density equal to or greater than the density of air shall discharge vapor to the atmosphere only through an *approved* treatment system in accordance with Section 605.12.5 or a flaring system in accordance with Section 605.12.6. Systems containing more than 6.6 pounds (3 kg) of ~~flammable Group A2, A3, B2, or B3~~ refrigerants having a density less than the density of air shall be permitted to discharge vapor to the atmosphere provided that the point of discharge is located outside of the structure at not less than 15 feet (4572 mm) above the adjoining grade level and not less than 20 feet (6096 mm) from any window, ventilation opening or *exit*.

Add new text as follows:

605.12.2.1 Group A2L refrigerant. Systems containing more than 6.6 pounds (3 kg) of Group A2L refrigerant shall discharge vapor directly to atmosphere where the fire code official determines, on review of an engineering analysis prepared in accordance with Section 104.7.2, that a fire hazard would not result from atmospheric discharge of Group A2L refrigerant.

Revise as follows:

605.12.4 Ammonia and Group B2L refrigerant. Systems containing more than 6.6 pounds (3 kg) of ammonia or Group B2L refrigerant shall discharge vapor to the atmosphere in accordance with one of the following methods:

1. Directly to atmosphere where the *fire code official* determines, on review of an engineering analysis prepared in accordance with Section 104.7.2, that a fire, health or environmental hazard would not result from atmospheric discharge of ammonia or B2L refrigerant.
2. Through an *approved* treatment system in accordance with Section 605.12.5.
3. Through a flaring system in accordance with Section 605.12.6.
4. ~~Through~~ For ammonia, through an *approved* ammonia diffusion system in accordance with Section 605.12.7.
5. By other *approved* means.

Exception: Ammonia/water absorption systems containing less than 22 pounds (10 kg) of ammonia and for which the ammonia circuit is located entirely outdoors.

Reason:

ASHRAE 34 changed the grouping of refrigerants adding two new categories, A2L and B2L. These refrigerants are lower flammable refrigerants. The refrigerants do not readily ignite and do not pose the same hazard as A2, A3, B2, and B3 refrigerants. With the addition of these new refrigerants, revisions are necessary to these section. Ammonia is a Group B2L refrigerant, hence, there are already special requirements. The modification will allow other B2L refrigerants to meet the same requirements.

A2L refrigerants have similar flammability characteristics to ammonia. Hence, allowance for the evaluation of ignition should apply similar to ammonia. The text in Section 606.12.3.1 is similar to item 1 in Section 606.12.5. Item 1 of Section 606.12.5 also includes an evaluation of the health or environmental hazard which would not apply to A2L refrigerants.

Cost Impact

The code change proposal will decrease the cost of construction .

Group A2L refrigerants will be treated similar to ammonia regarding the flammability.

Internal ID: 1317

F82-18

IFC: 605.12.4

Proponent: Jeffrey Shapiro, representing International Institute of Ammonia Refrigeration
(jeff.shapiro@intlcodeconsultants.com)

2018 International Fire Code

Revise as follows:

605.12.4 Ammonia refrigerant. Systems containing more than 6.6 pounds (3 kg) of ammonia refrigerant shall discharge vapor to the atmosphere in accordance with one of the following methods:

1. Directly to atmosphere where the *fire code official* determines, on review of an ~~engineering~~ analysis prepared in accordance with Section 104.7.2, that a ~~fire, health or environmental~~ hazard would not result from atmospheric discharge of ammonia.
2. Through an *approved* treatment system in accordance with Section 605.12.5.
3. Through a flaring system in accordance with Section 605.12.6.
4. Through an *approved* ammonia diffusion system in accordance with Section 605.12.7.
5. By other *approved* means.

Exception: Ammonia/water absorption systems containing less than 22 pounds (10 kg) of ammonia and for which the ammonia circuit is located entirely outdoors.

Reason:

Although an engineer may perform release modeling and analysis associated with 605.12.4 Item 1, that's not always the case. Individuals with expertise in dispersion modeling may or may not be engineers. Inclusion of the word "engineering" in this provision suggests that an engineer is necessary to perform the analysis, which seems to preclude selection of a qualified individual as specified in Section 104.7.2 and to supersede state engineering practice acts, which may or may not require an engineer for this work.

Elimination of the fire and environmental analysis is based on experience with this section indicating that neither will result from an emergency relief vent installed and located in accordance with code requirements. Ammonia's lower flammability limit is in the range of 160,000 ppm (16% in air), and it becomes too rich to burn in the range of 250,000 ppm (25% in air). Achieving a stable mix of these concentrations in open air from a vent release isn't reasonably possible, and the difficulty of ammonia ignition in an outdoor environment is recognized by UN/DOT, which does not classify ammonia as flammable for shipping purposes. I'm only aware of rare cases of outdoor ignitions when large liquid spills have occurred outside, and this section is specifically scoped to vapor-only releases. With respect to the environmental analysis, ammonia is a natural refrigerant consisting of nitrogen and hydrogen, which are readily dissipated into the atmosphere upon release. While the release may be noxious, ammonia vapor released into open air will not cause an environmental risk.

Cost Impact

The code change proposal will decrease the cost of construction .

The proposed change will provide additional options with respect to selecting a suitable design professional and will eliminate the need to perform some aspects of release analysis where the results are known before the analysis is performed.

Internal ID: 576

F83-18 Part I

IFC: 605.17.1; IMC: [F] 1106.5.1)

Proponent: Jeffrey Shapiro, representing Self (jeff.shapiro@intlcodeconsultants.com)

THIS IS A 2 PART CODE CHANGE PROPOSAL. PART I WILL BE HEARD THE IFC COMMITTEE, PART II WILL BE HEARD BY THE IMC COMMITTEE. PLEASE SEE THE TENTATIVE HEARING ORDERS FOR THE RESPECTIVE COMMITTEES.

2018 International Fire Code

Revise as follows:

605.17.1 Refrigerant detection system. Ventilation system activation. ~~The machinery room Ventilation shall be provided with a refrigerant detection system. The refrigerant detection system activated by the refrigerant detection system in the machinery room.~~ Refrigerant detection shall be in accordance with Section 605.8 and all of the following:

1. The detectors shall activate at or below a refrigerant concentration of 25 percent of the LFL.
2. Upon activation, the detection system shall activate the emergency ventilation system in Section 605.17.3.
3. The detection, signaling and control circuits shall be supervised.

2018 International Mechanical Code

Revise as follows:

[F] 1106.5.1 Refrigerant detection system. Ventilation system activation. ~~The machinery room Ventilation shall be provided with a refrigerant detection system. The refrigerant detection system activated by the refrigerant detection system in the machinery room.~~ Refrigerant detection shall be in accordance with Section 605.8 of the International Fire Code and all of the following:

1. The detectors shall activate at or below a refrigerant concentration of 25% of the LFL.
2. Upon activation, the detection system shall activate the emergency ventilation system required by Section 1106.5.2.
3. The detection, signaling and control circuits shall be supervised.

Internal ID: 2024

F83-18 Part II

IMC: 1106.4, 1106.5; IFC: [M]605.17

Proponent: Jeffrey Shapiro, representing Self (jeff.shapiro@intlcodeconsultants.com)

2018 International Mechanical Code

Revise as follows:

1106.4 Flammable refrigerants. Where refrigerants of Groups A2, A3, B2 and B3 are used, the *machinery room* shall conform to the Class 1, Division 2, *hazardous location* classification requirements of NFPA 70.

Exceptions:

1. Ammonia *machinery rooms* that are provided with *ventilation* in accordance with Section 1106.3.
2. *Machinery rooms* for systems containing Group A2L *refrigerants* that are provided with ventilation in accordance with Section 1106.5.

1106.5 Special requirements for Group A2L refrigerant machinery rooms. Machinery rooms ~~for with~~ systems containing Group A2L refrigerants ~~shall comply with Sections 1106.5.1 through 1106.5.3.~~ **Exception:** ~~Machinery rooms conforming to the Class 1 that do not conform with the Class I, Division 2, hazardous location classification electrical requirements of NFPA 70 are not required to, as permitted by Section 1106.4 Exception 2, shall comply with Sections 1106.5.1 and 1106.5.2 through 1106.5.3.~~

2018 International Fire Code

Revise as follows:

[M] 605.17 Special requirements for Group A2L refrigerant machinery rooms. Machinery rooms with systems containing Group A2L refrigerants ~~shall comply with Sections 605.17.1 through 605.17.3.~~ **Exception:** ~~Machinery rooms conforming to the Class 1 that do not conform with the Class I, Division 2 hazardous location classification electrical requirements of NFPA 70, as permitted by Section 605.16 Exception 2, shall comply with Sections 605.17.1 through 605.17.3.~~

Reason:

Editorial clarification. The current exception format of IFC Section 605.17 gives this section the appearance of being a circular requirement with Section 605.16 (IMC section are similarly structured). No technical change is intended by this proposal. The revision to Section 605.17.1 is for correlation with Section 605.16 Exception 2, which references Section 605.17 as a "ventilation" requirement only. Leak detection is already required, and the purpose of 605.17.1 is to specify activation of ventilation by the detection system, not to create another requirement to have a detection system. IMC changes are proposed to make the sections consistent. For disclosure, I represent IAR, which has an interest in the refrigeration industry, but this proposal is not being submitted on IAR's behalf. I am submitting the proposal based on my personal interest and expertise in the refrigeration industry and my interest in clarity of refrigeration related requirements as a consultant to the ASHRAE 15 Committee.

Cost Impact

The code change proposal will not increase or decrease the cost of construction .

Editorial clarification.

Internal ID: 3464

F84-18

IFC: 606.1 (New), 606.2, 606.3, 606.3.1, 606.3.2, 606.3.3, 606.3.4, 606.4, 606.5 (New), 606.5.1, 606.5.2, 606.5.3, 606.6 (New), 606.6.1, 606.6.2, 606.6.2.1, 606.6.2.2, 606.6.2.3, 606.6.2.4

Proponent: Michael O'Brian, Chair, representing FCAC (fcac@iccsafe.org)

2018 International Fire Code

Add new text as follows:

606.1 General. Elevators and conveying systems required by this code or the International Building Code shall comply with Chapter 30 of the International Building Code and Sections 606.2 through 606.6

Revise as follows:

~~606.1~~**606.2 Emergency operation.** Existing elevators with a travel distance of 25 feet (7620 mm) or more shall comply with the requirements in Chapter 11 ~~of this code.~~ New elevators shall be provided with Phase I emergency recall operation and Phase II emergency in-car operation in accordance with ASME A17.1/CSA B44.

~~606.2~~**606.3 Standby power.** In buildings and structures where standby power is required or furnished to operate an elevator, standby power shall be provided in accordance with Section 1203 ~~of this code.~~ Operation of the system shall be in accordance with Sections ~~606.2.1~~**606.3.1** through ~~606.2.4~~ **606.3.4**.

~~606.2.1~~**606.3.1 Manual transfer.** Standby power shall be manually transferable to all elevators in each bank.

~~606.2.2~~**606.3.2 One elevator.** Where only one elevator is installed, the elevator shall automatically transfer to standby power within 60 seconds after failure of normal power.

~~606.2.3~~**606.3.3 Two or more elevators.** Where two or more elevators are controlled by a common operating system, all elevators shall automatically transfer to standby power within 60 seconds after failure of normal power where the standby power source is of sufficient capacity to operate all elevators at the same time. Where the standby power source is not of sufficient capacity to operate all elevators at the same time, all elevators shall transfer to standby power in sequence, return to the designated landing and disconnect from the standby power source. After all elevators have been returned to the designated level, not less than one elevator shall remain operable from the standby power source.

~~606.2.4~~**606.3.4 Machine room ventilation.** Where standby power is connected to elevators, the machine room ventilation or air conditioning shall be connected to the standby power source.

[BE] 606.3~~606.4~~ **Emergency signs.** An *approved* pictorial sign of a standardized design shall be posted adjacent to each elevator call station on all floors instructing occupants to use the exit stairways and not to use the elevators in case of fire. The sign shall read: IN FIRE EMERGENCY, DO NOT USE ELEVATOR. USE EXIT STAIRS.

Exceptions:

1. The emergency sign shall not be required for elevators that are part of an accessible *means of egress* complying with Section 1009.4.
2. The emergency sign shall not be required for elevators that are used for occupant self-evacuation in accordance with Section 3008 of the International Building Code.

Add new text as follows:

606.5 Maintenance of elevators. Elevator features and lobbies required by Section 3006 of the International Building Code shall be maintained and in accordance with Sections 606.5.1 thru 606.5.3

Revise as follows:

~~606.4~~**606.5.1 Fire service access elevator elevators and lobbies.** Where fire service access elevators are required by Section 3007 of the International Building Code, the fire service access elevator fire protection and safety features required by Section 3007 of the International Building Code shall be maintained and lobbies shall be maintained free of storage and furniture.

~~606.5~~**606.5.2 Occupant evacuation elevator elevators and lobbies.** Where occupant evacuation elevators

are provided in accordance with Section 3008 of the International Building Code, the occupant evacuation elevator fire protection and safety features and lobbies required by Section 3008 of the International Building Code shall be maintained and maintained free of storage and furniture.

~~606.6~~606.5.3 Water protection of hoistway enclosures. Methods to prevent water from infiltrating into a hoistway enclosure required by Section 3007.3 and Section 3008.3 of the International Building Code shall be maintained.

Add new text as follows:

606.6 Elevator keys. All elevators shall be provided with elevator car door and fire-fighter service keys in accordance with Sections 606.6.1 thru 606.6.2.4

Revise as follows:

~~606.7~~606.6.1 Elevator key location. Keys for the elevator car doors and fire-fighter service keys shall be kept in an *approved* location for immediate use by the fire department.

~~606.8~~606.6.2 Standardized fire service elevator keys. Buildings with elevators equipped with Phase I emergency recall, Phase II emergency in-car operation, or a fire service access elevator shall be equipped to operate with a standardized fire service elevator key approved by the *fire code official*.

Exception: The owner shall be permitted to place the building's nonstandardized fire service elevator keys in a key box installed in accordance with Section 506.1.2.

~~606.8.1~~606.6.2.1 Requirements for standardized fire service elevator keys. Standardized fire service elevator keys shall comply with all of the following:

1. All fire service elevator keys within the jurisdiction shall be uniform and specific for the jurisdiction. Keys shall be cut to a uniform key code.
2. Fire service elevator keys shall be of a patent-protected design to prevent unauthorized duplication.
3. Fire service elevator keys shall be factory restricted by the manufacturer to prevent the unauthorized distribution of key blanks. Uncut key blanks shall not be permitted to leave the factory.
4. Fire service elevator keys subject to these rules shall be engraved with the words "~~DO NOT~~ DO NOT DUPLICATE."

~~606.8.2~~606.6.2.2 Access to standardized fire service keys. Access to standardized fire service elevator keys shall be restricted to the following:

1. Elevator owners or their authorized agents.
2. Elevator contractors.
3. Elevator inspectors of the jurisdiction.
4. *Fire code officials* of the jurisdiction.
5. The fire department and other emergency response agencies designated by the *fire code official*.

~~606.8.3~~606.6.2.3 Duplication or distribution of keys. A person shall not duplicate a standardized fire service elevator key or issue, give, or sell a duplicated key unless in accordance with this code.

~~606.8.4~~606.6.2.4 Responsibility to provide keys. The building owner shall provide up to three standardized fire service elevator keys where required by the *fire code official*, upon installation of a standardized fire service key switch or switches in the building.

Reason:

This is one of 17 proposals being submitted as a package relating to technical and organizational changes proposed for Chapter 6. While the Fire Code Committee will consider each proposal independently, the intent is for approval of all proposals in this package which have been submitted as a correlated set of companion code change proposals.

The new scoping section for elevators correlates Section 606 with Chapter 30 of the International Building Code.

Clarity is provided regarding the maintenance of not only the elevator lobbies, but also the fire protection and safety features of the elevator. Clarity is also provided in grouping together the sections for maintenance of elevators and lobbies (the new Section 606.5) and the sections for elevator keys (the new Section 606.6)

It is the intention of F-CAC that this proposal correlate with the B-CAC Proposal being heard by the IBC-E Technical Committee to match the elevator signage requirements for standard and occupant evacuation elevators in both IBC Chapter 30 and IFC Chapter 6.

This proposal is submitted by the ICC Fire Code Action Committee (FCAC). The FCAC was established by the ICC Board of Directors to pursue opportunities to improve and enhance assigned International Codes with regard to fire safety and hazardous materials in new and existing buildings and facilities and the protection of life and property in wildland urban interface areas. In 2017 the Fire-CAC has held 3 open meetings. In addition, there were numerous conference calls, Regional Work Group and Task Group meetings for the current code development cycle, which included members of the committees as well as any interested parties, to discuss and debate the proposed changes. Related documentation and reports are posted on the FCAC website at: <https://www.iccsafe.org/codes-tech-support/cs/fire-code-action-committee-fcac/>

Cost Impact

The code change proposal will not increase or decrease the cost of construction .

This proposal clarifies already existing requirements.

Internal ID: 406

F85-18

IFC: 606.6 (New)

Proponent: Adria Reinertson, Riverside County Fire Department, representing Riverside County Fire Department, California Fire Chiefs Association (adriar@moval.org)

2018 International Fire Code

Add new text as follows:

606.6 Storage within elevator lobbies. Where hoistway opening protection is required by Section 3006.2 of the International Building code, elevator lobbies shall be maintained free of storage.

Reason:

There are existing provisions to prohibit storage of furniture and combustibles in fire service and occupant evacuation elevators. This proposal addresses combustible storage in other elevator lobbies requiring hoistway protection.

Cost Impact

The code change proposal will not increase or decrease the cost of construction .

This proposal clarifies that storage is not permitted in any protected hoistway and does not have an impact on construction costs.

Internal ID: 979

F86-18

IFC: 606.8, 606.8.1

Proponent: Kevin Brinkman, representing National Elevator Industry, Inc. (klbrinkman@neii.org)

2018 International Fire Code

Revise as follows:

606.8 Standardized fire service elevator keys. Buildings with elevators equipped with Phase I emergency recall, Phase II emergency in-car operation, or a fire service access elevator shall be equipped to operate with a standardized fire service elevator key approved by the *fire code official* or a standardized key in accordance with ASME A17.1/CSA B44.

Exception: The owner shall be permitted to place the building's nonstandardized fire service elevator keys in a key box installed in accordance with Section 506.1.2.

606.8.1 Requirements for standardized fire service elevator keys. Standardized fire service elevator keys shall comply with all of the following:

1. All fire service elevator keys within the jurisdiction shall be uniform and ~~specific for the jurisdiction.~~ approved in accordance with Section 606.8. Keys shall be cut to a uniform key code.
2. Fire service elevator keys shall be of a patent-protected design to prevent unauthorized duplication.
3. Fire service elevator keys shall be factory restricted by the manufacturer to prevent the unauthorized distribution of key blanks. Uncut key blanks shall not be permitted to leave the factory.
4. Fire service elevator keys subject to these rules shall be engraved with the words "DO NOT DUPLICATE."

Reason:

To eliminate a potential conflict with ASME A17.1/CSA B44 and all jurisdictions more flexibility in selection of a standardized keys.

Cost Impact

The code change proposal will not increase or decrease the cost of construction .

This change will not impact cost since it allows more options and eliminates a potential conflict.

Internal ID: 1443

F87-18

IFC: 606.8.5 (New), 315.3.3

Proponent: Michael O'Brian, Chair, representing FCAC (fcac@iccsafe.org)

2018 International Fire Code

Add new text as follows:

606.8.5 Storage. Furniture, materials or combustible waste shall not be stored in elevator cars or elevator machine rooms.

Exception: Blankets used for protection of elevator cab walls during construction or renovation.

Revise as follows:

315.3.3 Equipment rooms. Combustible material shall not be stored in boiler rooms, mechanical rooms, elevator machine rooms, electrical equipment rooms or in *fire command centers* as specified in Section 508.1.5.

Reason:

This is one of 17 proposals being submitted as a package relating to technical and organizational changes proposed for Chapter 6. While the Fire Code Committee will consider each proposal independently, the intent is for approval of all proposals in this package which have been submitted as a correlated set of companion code change proposals.

These changes will clarify that elevator cars and machine rooms are not to be used for storage. An exception is provided for blankets that are used for protecting the elevator cab walls.

This proposal is submitted by the ICC Fire Code Action Committee (FCAC). The FCAC was established by the ICC Board of Directors to pursue opportunities to improve and enhance assigned International Codes with regard to fire safety and hazardous materials in new and existing buildings and facilities and the protection of life and property in wildland urban interface areas. In 2017 the Fire-CAC has held 3 open meetings. In addition, there were numerous conference calls, Regional Work Group and Task Group meetings for the current code development cycle, which included members of the committees as well as any interested parties, to discuss and debate the proposed changes. Related documentation and reports are posted on the FCAC website at: <https://www.iccsafe.org/codes-tech-support/cs/fire-code-action-committee-fcac/>

Cost Impact

The code change proposal will not increase or decrease the cost of construction .

These areas are currently not permitted to be used for storage purposes.

Internal ID: 408

F88-18

IFC: 701.6

Proponent: Stephen DiGiovanni, representing ICC Ad Hoc Committee on Tall Wood Buildings (TWB) (TWB@iccsafe.org)

2018 International Fire Code

Revise as follows:

701.6 Owner's responsibility. The owner shall maintain an inventory of all required *fire-resistance-rated* construction, construction installed to resist the passage of smoke and the construction included in Sections 703 through 707 and Sections 602.4.1 and 602.4.2 of the International Building Code. Such construction shall be visually inspected by the *owner* annually and properly repaired, restored or replaced where damaged, altered, breached or penetrated. Records of inspections and repairs shall be maintained. Where concealed, such elements shall not be required to be visually inspected by the *owner* unless the concealed space is accessible by the removal or movement of a panel, access door, ceiling tile or similar movable entry to the space.

Reason:

The Ad Hoc Committee on Tall Wood Buildings (TWB) was created by the ICC Board to explore the science of tall wood buildings and take action on developing code changes for tall wood buildings. The TWB has created several code change proposals with respect to the concept of tall buildings of mass timber and the background information is at the end of this Statement. Within the statement are important links to information, including documents and videos, used in the deliberations which resulted in these proposals.

The Ad Hoc Committee has discussed a number of proposals to potentially increase the permitted height and area for Type IV structures, specifically mass timber buildings. One of the basic requirements incorporated into these proposed increased heights and areas is the added active and passive protection features to these structures.

Specific to this code change proposal, in the related code change proposals for Type IV-A and Type IV-B, mass timber walls and ceilings, except where permitted, will be required to meet a fire-resistance performance with a specified amount provided with gypsum board or its equivalent.

The greater permitted heights and areas are being proposed based on the requirement of this added level of passive protection. It would seem obvious that we should incorporate a methodology to insure this passive protection remains in place.

This is not an undue burden to the building owner or management. Section 701.6 of the International Fire Code permits these inspections to be done by current building staff. Local jurisdictions may or may not require the annual inspection to be reported. The managing authority simply must keep a record of such inspections and take steps to correct any deficiencies identified.

Some have suggested that we do not require other types of construction to inspect the gypsum board annually to insure it has not been compromised. Other forms of construction do not contribute to the fuel load in the manner mass timber construction potentially will do. If we are going to permit mass timber construction to greater heights than previously permitted it means we are relying on the performance of active and passive protection to protect the occupants of the building in the event of a fire. We currently require the active protection to be inspected for performance it is time we require the same for the passive.

Background information: The ICC Board approved the establishment of an ad hoc committee for tall wood buildings in December of 2015. The purpose of the ad hoc committee is to explore the science of tall wood buildings and to investigate the feasibility and take action on developing code changes for tall wood buildings. The committee is comprised of a balance of stakeholders with additional opportunities for interested parties to participate in the four Work Groups established by the ad hoc committee, namely: Code; Fire; Standards/Definitions; and Structural. For more information, be sure to visit the ICC website <https://www.iccsafe.org/codes-tech-support/cs/icc-ad-hoc-committee-on-tall-wood-buildings/> (link active and up to date as of 12/27/17). As seen in the "Meeting Minutes and Documents" and "Resource Documents" sections of the committee web page, the ad hoc committee reviewed a substantial amount of information in order to provide technical justification for code proposals.

The ad hoc committee developed proposals for the followings code sections. The committee believes this package of code changes will result in regulations that adequately address the fire and life safety issues of tall mass timber buildings.

IBC Code Section	Description
403.3.2	Water supply requirements for fire pumps in high rise buildings of Type IVA and IVB construction.
504.3	Allowable building height (feet) for buildings of Type IVA, IVB and IVC construction. No changes to Type IV HT construction.
504.4	Allowable building height (stories) for buildings of Type IVA, IVB and IVC construction. No changes to Type IV HT.
506.2	Allowable building area for buildings of Type IVA, IVB and IVC construction. No changes to Type IV HT.
508.4.4.1 509.4.1.1 (new)	Requirements for mass timber building elements serving as fire barriers or horizontal assemblies in buildings of Type IVB or IVC construction.
602.4	Type of Construction requirements for new proposed types of construction: Types IVA, IVB and IVC. No changes to Type IV HT construction. Includes definitions for new terms: Mass timber and Noncombustible protection (mass timber). THIS IS THE KEY CODE CHANGE PROPOSAL WHICH OUTLINES THE CONSTRUCTION REQUIREMENTS FOR THE PROPOSED NEW TYPE OF MASS TIMBER BUILDINGS. THE PROPOSAL ALSO ADDRESSES CONCEALED SPACES, ADHESIVE PERFORMANCE AND EXTERIOR WALL PROTECTION.
703.8 (new)	The performance method to determine the increase to the fire resistance rating provided by noncombustible protection applied to the mass timber building element.
703.9 (new)	Requirements for sealants and adhesives to be placed at abutting edges and intersections of mass timber building elements. The reason statement references a Group B proposal to Chapter 17 for special inspection requirements of sealants and adhesives.
718.2.1	Requirements on the use of mass timber building elements used for Fireblocking.
722.7 (new)	Requirements for the fire resistance rating of mass timber elements, including minimum required protection and gypsum board attachment requirements.
3102	Requirements for membrane structures using Type IV HT construction.
3314.7 (new)	New special precautions during construction of buildings of Types IVA, IVB and IVC construction: Standpipes; Water supply for fire department connections; Noncombustible protection required for mass timber elements as construction height increases.
Appendix	Requirements for walls, floors and roofs of Type IV HT construction in buildings located in Fire Districts.
IFC Code Section	Description
701.6	Requirements which stipulate the owner's responsibility to maintain inventory of all required fire resistance rated construction in buildings of Types IVA and IVB construction. This includes an annual inspection and proper repair where necessary.
Proposed changes to be submitted in 2019 Group B	
IBC Chapter 17	Required special inspections of mass timber construction <ul style="list-style-type: none"> • Structural • Sealants and adhesives (see IBC 703.8)
IBC Chapter 23	An update to referenced standard APA PRG 320 Standard for Performance –rated Cross-laminated Timber which is currently undergoing revision to ensure the adequacy of the adhesives under fire conditions.

In addition, fire tests designed to simulate the three new construction types (Types IVA, IVB and IVC) in the ad hoc committee proposals were conducted at the Alcohol Tobacco and Firearms test lab facility. The TWB was involved in the design of the tests, and many members witnessed the test in person or online. The results of the series of 5 fire tests provide additional support for these proposals, and validate the fire performance for each of the types of construction proposed by the committee. The fire tests consisted of one-bedroom apartments on two levels, with both apartments having a corridor leading to a stair. The purpose of the tests was to address the contribution of mass timber to a fire, the performance of connections, the performance of through-penetration fire stops, and to evaluate conditions for responding fire personnel.

To review a summary of the fire tests, please visit:

<http://bit.ly/ATF-firetestreport>

To watch summary videos of the fire tests, which are accelerated to run in 3 ½ minutes, please visit:

<http://bit.ly/ATF-firetestvideos>

Both of these links were confirmed active on 12/27/17.

Cost Impact

The code change proposal will not increase or decrease the cost of construction .

This section provides information that was not previously set forth in the code, and does not change the requirements of current code, thus there is no cost impact when compared with present requirements.

Internal ID: 962

F89-18

IFC: 703.2 (New), 704.2 (New)

Proponent: Michael O'Brian, Chair, representing FCAC (fcac@iccsafe.org)

2018 International Fire Code

Add new text as follows:

703.2 Repair of Penetrations. Where damaged, materials used to protect membrane- and through-penetrations shall be replaced or restored with materials or systems that meet or exceed the code requirements applicable at the time when the assembly was constructed, remodeled or altered.

704.2 Repair of Joints and Voids. Where damaged, materials used to protect joints and voids shall be replaced or restored with materials or systems that meet or exceed the code requirements applicable at the time when the assembly was constructed, remodeled or altered.

Reason:

This proposal compliments the work of the Fire Code Action Committee during the 2015-2017 Code Development Cycle on expanding the maintenance requirements in Chapter 7 of the IFC.

While the current language in Section 703.1 of the IFC addresses maintenance of fire-resistance-rated construction, it is not very specific. Clearly, the intent of Section 703.1 is that when protection of penetrations and joints has been damaged, they need to be repaired, not simply "maintained" in a damaged condition. The language proposed here clarifies that requirement.

This proposal recognizes that penetrations and joints that were protected in accordance with previous code editions may not have used the types of tested systems that are mandated by today's building codes. Consequently, the wording proposed here continues the allowance to grandfather installed penetration and joint seals when they are damaged, but requires that they be repaired to meet the requirements that were applicable when the penetration or joint protection was installed.

Conversely, where the current IBC requirements differ from those in effect at the time of construction, the IEBC already provides a procedure for complying with current IBC requirements in Section 803.6.

This proposal is submitted by the ICC Fire Code Action Committee (FCAC). The FCAC was established by the ICC Board of Directors to pursue opportunities to improve and enhance assigned International Codes with regard to fire safety and hazardous materials in new and existing buildings and facilities and the protection of life and property in wildland urban interface areas. In 2017 the Fire-CAC has held 3 open meetings. In addition, there were numerous conference calls, Regional Work Group and Task Group meetings for the current code development cycle, which included members of the committees as well as any interested parties, to discuss and debate the proposed changes. Related documentation and reports are posted on the FCAC website at: <https://www.iccsafe.org/codes-tech-support/cs/fire-code-action-committee-fcac>

Cost Impact

The code change proposal will not increase or decrease the cost of construction .

The assumption of the current code is when damaged, the materials or systems used to protect penetrations and joints will be replaced or restored. This proposal simply clarifies the requirements for replacing or restoring the materials or systems.

Internal ID: 317

F90-18

IFC: 704.1

Proponent: William Koffel, representing Firestop Contractors International Association (wkoffel@koffel.com)

2018 International Fire Code

Revise as follows:

704.1 Maintaining protection. Where required when the building was originally constructed, materials and systems used to protect joints and voids in the following locations shall be maintained. The materials and systems shall be securely attached to or bonded to the adjacent construction, without openings visible through the construction.

1. Joints in or between *fire-resistance-rated* walls, floors or floor/ceiling assemblies and roof or roof/ceiling assemblies.
2. Joints in *smoke barriers*.
3. Voids at the intersection of a horizontal floor assembly and an exterior curtain wall.
4. Voids at the intersection of a horizontal smoke barrier and an exterior curtain wall.
5. Voids at the intersection of a nonfire-resistance-rated floor assembly and an exterior curtain wall.
6. Voids at the intersection of a vertical *fire barrier* and an exterior curtain wall.
7. Voids at the intersection of a vertical *fire barrier* and a nonfire-resistance-rated roof assembly.

Unprotected joints and voids do not need to be protected where such joints and voids were not required to be protected when the building was originally constructed. Where the system design number is known, the system shall be inspected to the listing criteria and manufacturer's installation instructions.

Reason:

During the 2018 Code Development Cycle this language was added to the through penetration firestop section but not the section covering fire resistant joint systems. This was apparently was an oversight on our part as the proponent and was not identified during the hearing process. For the same reasons that it is appropriate for through penetration firestop systems, it is appropriate for joint systems. The listing information, where available, allows one to identify the maintenance requirements provided by the manufacturer. Therefore, we've added this to bring consistency to the code sections so that all firestopping, penetrations and joints, have the same requirements.

Cost Impact

The code change proposal will not increase or decrease the cost of construction .

The fire-resistive joints are to be maintained anyway. Therefore, this should not increase nor decrease the cost of construction.

Internal ID: 2266

F91-18

IFC: SECTION 708 (New), 708.1 (New)

Proponent: Bill McHugh, The McHugh Company, representing National Fireproofing Contractors Association (billmchugh-jr@att.net)

2018 International Fire Code

Add new text as follows:

SECTION 708 SPRAY FIRE-RESISTIVE MATERIALS AND INTUMESCENT FIRE-RESISTIVE COATINGS

708.1 Maintaining Protection. The fire-resistance ratings of building elements, components or assemblies shall be maintained. The materials shall be securely bonded, not exhibit cracks, voids, spalls, delamination or any exposure to the substrate and be in accordance with the permitted fireproofing thicknesses. The materials shall be maintained in accordance with the listing and manufacturers instructions, where known.

Reason:

We compliment the work of the Fire Code Action Committee and its successful F-113 proposal that resulted in new sections for maintaining assemblies in the IFC Chapter 7, Fire and Smoke Protection Features. There were several needed sections added to the International Fire Code through the F-113 Proposal. However, there was no section submitted at the time by the industry for sprayed fire-resistive materials (SFRM) or intumescent fire-resistive materials (IFRM) Fireproofing. This proposal adds the section to add a section on maintaining protection of building elements, structural members or assemblies receiving SFRM and IFRM Fireproofing.

Cost Impact

The code change proposal will not increase or decrease the cost of construction .

This code proposal does not increase the cost of construction because all Fire and Smoke Protection Features are supposed to be maintained currently.

Internal ID: 1977

F92-18 Part I

IFC: Chapter 8, SECTION 801, 801.1, 808 (New), 808.1 (New), 808.2 (New), 808.3 (New), 808.4 (New), 808.5 (New)

Proponent: Ali Fattah, City of San Diego, representing Self

2018 International Fire Code

CHAPTER 8 INTERIOR FINISH, DECORATIVE MATERIALS AND FURNISHINGS

SECTION 801 GENERAL

801.1 Scope. The provisions of this chapter shall govern interior finish, interior trim, furniture, furnishings, decorative materials and decorative vegetation ~~in~~ on the interior and exterior of buildings. Existing buildings shall comply with Sections 803 through 808. New buildings shall comply with Sections 804 through ~~808~~809, and Section 803 of the International Building Code.

808 OUTDOOR ARTIFICIAL DECORATIVE VEGETATION

808.1 General. Artificial decorative vegetation placed outdoors, within 30 feet (9140 mm) of a building, or on an occupied roof of a building shall comply with this section.

808.2 Testing. Artificial decorative vegetation shall meet the flame propagation performance criteria of Test Method 1 or Test Method 2, as appropriate, of NFPA 701. Meeting such criteria shall be documented and certified by the manufacturer in an approved manner. Alternatively, the artificial decorative vegetation shall be tested in accordance with NFPA 289, using the 20 kW ignition source, and shall have a maximum heat release rate of 100 kW.

808.3 Electrical fixtures and wiring. The use of unlisted electrical wiring and lighting on artificial decorative

vegetation shall be prohibited. The use of electrical wiring and lighting on artificial trees constructed entirely of metal shall be prohibited

808.4 Candles and open flames. Candles and open flames shall not be used on or within 5 feet of artificial decorative vegetation.

808.5 Maintenance. Artificial decorative vegetation shall be tested to demonstrate that the flame propagation performance criterion or the heat release criterion from Section 808.2, as appropriate, remains effective for the period for which the artificial decorative vegetation remains in service, as approved by the fire code official. Materials tested to Chapter 16 of NFPA 701 that retain the flame propagation performance shall be deemed acceptable.

Internal ID: 927

F92-18 Part II

IBC: Chapter 8, SECTION 801, 801.1, 802.3, 807 (New), 807.1 (New), 807.2 (New), 807.3 (New), 807.4 (New)

Proponent: Ali Fattah, City of San Diego, representing Self

2018 International Building Code

CHAPTER 8 INTERIOR FINISHES AND DECORATIVE MATERIALS

SECTION 801 SCOPE

801.1 Scope. The provisions of this chapter shall govern the use of materials used as *interior finishes, trim* and *decorative materials*.

[F] 802.3 Decorative materials and trim. *Decorative materials* and *trim* shall be restricted by combustibility, fire performance or flame propagation performance criteria in accordance with Section 806 for the interior of the building and Section 807 for the exterior of the building.

807 ARTIFICIAL DECORATIVE VEGETATION ON BUILDINGS AND IN OUTDOOR OCCUPANCIES

807.1 General. Fixed artificial decorative vegetation placed in outdoor occupancies or on an occupied roof of a building shall comply with this section.

807.2 Testing. Artificial decorative vegetation shall meet the flame propagation performance criteria of Test Method 1 or Test Method 2, as appropriate, of NFPA 701. Meeting such criteria shall be documented and certified by the manufacturer in an approved manner. Alternatively, the artificial decorative vegetation shall be tested in accordance with NFPA 289, using the 20 kW ignition source, and shall have a maximum heat release rate of 100 kW.

807.3 Electrical fixtures and wiring. The use of unlisted electrical wiring and lighting on artificial decorative vegetation shall be prohibited. The use of electrical wiring and lighting on artificial trees constructed entirely of metal shall be prohibited.

807.4 Ignition sources and maintenance. Ignition sources and maintenance of outdoor artificial vegetation shall be in accordance with Section 808.4 and 808.5 of the IFC.

Reason:

The proposed code change is in response to the increased use of decorative artificial vegetation on occupied roofs, within interior courts in buildings and outdoor occupancies such as Group A-5 stadiums. In the event that plastics in the decorative combustible vegetation ignites it can spread fire to surrounding buildings and this potential was very visible when artificial palm trees on the pool deck at the Las Vegas Cosmopolitan Hotel ignited in July of 2015. The IBC and IFC presently only specifically regulate decorative artificial vegetation in buildings through the requirements in Section 807.4 that was added in the last code cycle. The hazards are just as important in outdoor occupancies as they are in indoor occupancies.

Occupied roofs typically are classified as Group A-2 or A-3 occupancies and outdoor stadiums are classified as Group A-5 both of which accommodate large numbers of people. Additionally, when placed in close proximity to a building they can spread fire to a building if ignited.

Outdoor use poses weathering problems due to moisture, UV exposure or cleaning chemicals necessary to freshen up the vegetation. As a result, testing is required after weathering conditioning per the requirements of Chapter 16 in NFPA 701. Since there are no specific standards and tests done for this specific type of outdoor plastic compliance with the weathering accelerated weathering testing per ASTM D4329 and ASTM D4587 where fire retardant coating is used is not being required to allow the fire code official flexibility.





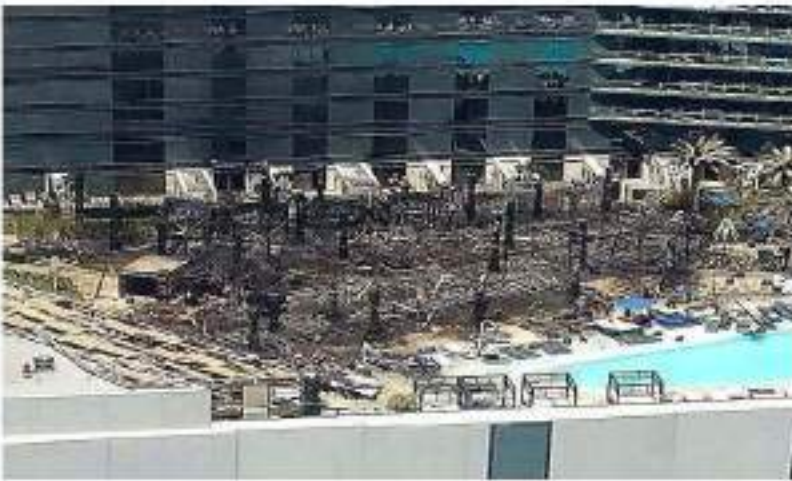

Cost Impact

The code change proposal will increase the cost of construction .

Artificial decorative vegetation protected with fire retardants need to be tested for outdoor weathering. This testing which is seen as necessary will increase the cost of these materials.

Internal ID: 2319

F93-18

IFC: 806.1.4 (New), Chapter 80

Proponent: Marcelo Hirschler, GBH International, representing GBH International (gbhint@aol.com)

2018 International Fire Code

Add new text as follows:

806.1.4 Fire retardant treatments for natural cut trees. Fire retardant treatments applied to natural cut trees shall be tested by an approved agency and shall comply with one of the following:

1. Both Test Method 1 and Test Method 2 of ASTM E3082.
2. Exhibit a maximum rate of heat release not exceeding 100 kW when applied in accordance with the manufacturer's recommendations and tested in accordance with section 5.5 of NFPA 289.

Add new standard(s) follows:

ASTM

ASTM International
100 Barr Harbor Drive, P.O. Box
C700
West Conshohocken PA 19428-
2959
US

E3082-17:

Standard Test Methods for Determining the Effectiveness of Fire Retardant Treatments for Natural Christmas Trees

Reason:

It has been found that many treatments are offered for sale that are said to improve the fire performance of natural Christmas trees. The Natural Christmas Tree Association has been very worried for some time about the efficacy of some of these products. It has been found that the use of poorly formulated and untested fire retardant treatments can accelerate the drying out of the Christmas tree and actually worsen the fire danger. The Natural Christmas Tree Association approached both ASTM (committee E05 on fire standards) and individual members off the NFPA Fire Tests committee to develop a test method for assessing whether the treatments offered for sale are actually doing as claimed by manufacturers. The state of California has a fire test that it uses to approve such treatments, based on a small scale fire test, but other states do not.

As a result of these concerns, ASTM has now developed and published ASTM E3082 for that purpose. It contains both a small scale test (Test Method 1) and a full scale test (Test Method 2). In order to comply with the requirements of ASTM E3082 a treatment must comply with both tests, and then it will be said to have "passed" the test. Test Method 1 is similar to the test used by the state of California for its requirements. Test Method 2 is a full scale heat release test largely based on UL Outline of Investigation 2358, "Fire Tests of Pre-Lit Artificial Seasonal Use Trees and Other Seasonal Decorative Items".

NFPA has developed a procedure within NFPA 289 (a heat release test for full scale individual fuel items) to also test Christmas tree treatments. The test in NFPA 289 (section 5.5) is similar (but not identical) to the full scale test in ASTM E3082 (Test Method 2) and does not have pass fail criteria. Therefore the pass fail criteria recommended are those used when testing to NFPA 289 in more than one section of the IFC (807.3, 807.4.1, 807.5.1.1, etc.), which are a heat release rate not exceeding 100 kW.

NFPA statistics show that, between 2011 and 2015, U.S. fire departments responded to an estimated 200 structure fires, per year, caused by Christmas trees resulting in an annual average of 6 deaths, 16 injuries and \$14.8 million in property damage. When comparing Christmas tree fires to other reported home fires, 1 out of every 32 home fires that began with a Christmas tree resulted in a death compared to 1 death out of every 143 reported home fires.

The use of an appropriate fire retardant treatment is a passive means or protection, which adds fire safety to the active means in 806.1.1 and 806.1.3.

Cost Impact

The code change proposal will increase the cost of construction .

This will provide added fire safety but it will require manufacturers of fire retardant treatments to conduct some fire testing to demonstrate the effectiveness of their products.

Analysis: A review of the standard proposed for inclusion in the code, ASTM E3082-17 Standard Test Methods for Determining the Effectiveness of Fire Retardant Treatments for Natural Christmas Trees, with regard to the ICC criteria for referenced standards (Section 3.6 of CP#28) will be posted on the ICC website on or before April 2, 2018.

Internal ID: 912

F94-18

IFC: 808.4

Proponent: Julius Ballanco, JB Engineering and Code Consulting, P.C., representing Bradley Corporation (JBENGINEER@aol.com)

2018 International Fire Code

Revise as follows:

808.4 Combustible lockers. Where lockers constructed of combustible materials are used, the lockers shall be considered to be interior finish and shall comply with Section 803.

Exception:

Lockers constructed entirely of wood and noncombustible materials shall be permitted to be used wherever interior finish materials are required to meet a Class C classification in accordance with Section 803.1.2.

Reason:

The current section is poorly worded. What is attempting to be required is for combustible lockers to comply with the interior finish requirements of Table 803.3. The proposed change clearly states the requirement.

The exception is not an exception to the requirements, it is simply an additional requirement. The exception would become the second sentence in the section stating the allowance of wood lockers without the need to be subjected to an ASTM E84 test.

Cost Impact

The code change proposal will not increase or decrease the cost of construction .

The change will clarify the requirements in the code.

Internal ID: 1503

F95-18

IFC: 808.4

Proponent: Misty Guard, representing Bradley Corporation (Misty.Guard@bradleycorp.com)

2018 International Fire Code

Revise as follows:

808.4 Combustible lockers. Where lockers constructed of combustible materials are used, the lockers shall be considered to be interior finish and shall comply with ~~Section 803~~Table 803.3.

Exception: Lockers constructed entirely of wood and noncombustible materials shall be permitted to be used wherever interior finish materials are required to meet a Class C classification in accordance with Section 803.1.2.

Reason:

The current requirement references all of Section 803, whereas the intent is to apply Table 803.3 for interior finish. Combustible lockers are made of different materials, including wood, ABS, and HDPE. If the material meets the interior finish requirements of Table 803.3 then they should be permitted.

The current Section 803 would appear to apply different requirements for wood, ABS, and HDPE lockers. The exception to allow any wood to be classified as Class C is acceptable. There is an implication that HDPE would be regulated differently than ABS. Section 803.9 could be incorrectly interpreted as applying to HDPE lockers. However, this section was never intended to apply to lockers. The original change adding this section addressed large areas of HDPE panels as an interior finish. No mention was made in the code change of lockers.

HDPE lockers have been installed for the last 25 years, as have ABS lockers. Many fire stations, schools, and health club like the added benefits of HDPE and ABS lockers. From a cleanliness and sanitation standpoints, HDPE and ABS lockers are superior to many metal lockers.

A study was completed by NFPA Research entitled, "Non-Residential Structure Fires That Originated in Lavatories, Locker Rooms or Coat Check Rooms," dated November 2017, authored by Marty Ahrens. The report shows no fire issue with HDPE or ABS lockers. There are no fire deaths reported from fires originating in a locker room. Hence, the perceived fire hazard does not exist with lockers in commercial building that meet the interior finish requirements of Table 803.3. This change is needed for clarification.

Bibliography:

Ahrens, M. (2017). Non-Residential Structure Fires that Originated in Lavatories, Locker Rooms or Coat Check Rooms. Quincy, MA: NFPA Research.

Cost Impact

The code change proposal will not increase or decrease the cost of construction .

The code change proposal will not increase or decrease the cost of construction.

Internal ID: 1852

F96-18

IFC: 808.5 (New)

Proponent: Marcelo Hirschler, GBH International, representing GBH International (gbhint@aol.com)

2018 International Fire Code

Add new text as follows:

808.5 Children's play structures added to existing buildings. Where children's play structures that exceed 10 feet (3048 mm) in height or 150 square feet (14 m²) in area are added inside an existing building they shall comply with Section 424 of the International Building Code.

Reason:

This is simply a pointer from the IFC to the IBC for children's play structures incorporated into existing occupancies. The fire testing that led to its inclusion into the IBC showed that these children's playground structures or play structures can release very large amounts of heat when they burn and need to be regulated.

The IBC (in Section 424) already regulates these structures for new buildings. However, the IBC deals with play structures at the time of construction of the entire building but play structures are often added, into malls or restaurants, after the certificate of occupancy has been granted. This proposal simply sends a pointer. Moreover as play structures age they are often removed and replaced and the IBC would normally not apply. Similarly, the IEBC would also not apply.

This section is both within the scope of the IFC and of its chapter 8, as follows:

IFC: 101.2 Scope. This code establishes regulations affecting or relating to structures, processes, premises and safeguards regarding all of the following:

1. The hazard of fire and explosion arising from the storage, handling or use of structures, materials or devices.
2. Conditions hazardous to life, property or public welfare in the occupancy of structures or premises.
3. Fire hazards in the structure or on the premises from occupancy or operation.
4. Matters related to the construction, extension, repair, alteration or removal of fire suppression or alarm systems.
5. Conditions affecting the safety of fire fighters and emergency responders during emergency operations.

IFC Chapter 8:

About this chapter: Chapter 8 provides requirements for interior finishes, decorative materials and furnishings in new and existing buildings so that they do not significantly add to or create fire hazards in buildings. The provisions tend to focus on occupancies with specific risk characteristics, such as vulnerability of occupants, density of occupants, lack of familiarity with the building and societal expectations of importance. This chapter is consistent with Chapter 8 of the International Building Code, which regulates the interior finishes and decorative materials of new buildings.

Cost Impact

The code change proposal will increase the cost of construction .

This code proposal has the potential effect of applying to children's play structures installed (or renewed) after the building has been occupied. They are potentially excluded from complying with the requirements now.

Internal ID: 1029

F97-18

IFC: 202, 901.1, 901.2, 901.2.1, 901.4, 901.4.1, 901.4.2, 901.4.3 (New) (IBC: 202, [F] 901.1, [F] 901.2, [F] 901.2.1, [F] 901.4, 901.4.1, 901.4.2, 901.4.3 (New))

Proponent: Dave Frable, U.S General Services Administration, representing U.S. General Services Administration (dave.frable@gsa.gov)

2018 International Fire Code

SECTION 901 GENERAL

Revise as follows:

901.1 Scope. The provisions of this chapter shall specify where fire protection and life safety systems are required and shall apply to the design, installation, inspection, operation, testing and maintenance of all *fire protection and life safety systems*.

901.2 Construction documents. The *fire code official* shall have the authority to require *construction documents* and calculations for all *fire protection and life safety systems* and to require permits be issued for the installation, rehabilitation or modification of any *fire protection and life safety system*. *Construction documents for fire protection and life safety systems* shall be submitted for review and approval prior to system installation.

901.2.1 Statement of compliance. Before requesting final approval of the installation, where required by the *fire code official*, the installing contractor shall furnish a written statement to the *fire code official* that the subject *fire protection and life safety system* has been installed in accordance with *approved* plans and has been tested in accordance with the manufacturer's specifications and the appropriate installation standard. Any deviations from the design standards shall be noted and copies of the approvals for such deviations shall be attached to the written statement.

901.3 Permits. Permits shall be required as set forth in Sections 105.6 and 105.7.

Delete and substitute as follows:

~~**901.4 Installation.** *Fire protection systems* shall be maintained in accordance with the original installation standards for that system. Required systems shall be extended, altered or augmented as necessary to maintain and continue protection where the building is altered, remodeled or added to. *Alterations to fire protection systems* shall be done in accordance with applicable standards.~~

901.4 Fire Protection and Life Safety Systems. *Fire protection and life safety systems shall be installed, repaired, operated, and maintained in accordance with this code and the International Building Code.*

Revise as follows:

901.4.1 Required fire protection and life safety systems. *Fire protection and life safety systems required by this code or the International Building Code shall be installed, repaired, operated, tested and maintained in accordance with this code. A fire protection system or life safety system for which a design option, exception or reduction to the provisions of this code or the International Building Code has been granted shall be considered to be a required system.*

901.4.2 Nonrequired fire protection and life safety systems. ~~A *fire protection system*~~ *Fire protection and life safety systems* or portion thereof not required by this code or the International Building Code shall be allowed to be furnished for partial or complete protection provided that such installed system meets the applicable requirements of this code and the International Building Code.

Add new text as follows:

901.4.3 Alterations in Buildings and Structures. For any alteration within a building or structure, the fire protection and life safety systems shall be extended, altered, or augmented to maintain and continue protection within the building or structure. Persons shall not remove or modify any fire protection or life safety system installed or maintained under the provisions of this code or the International Building Code without approval by the fire code official.

Reason:

The intent of this proposal is to address the need to acknowledge “life safety systems” (see Title of Chapter) with a defined term and to reference life safety systems when referencing “fire protection systems”. The subject term is used in the title of IFC Chapter 9, Fire Protection and Life Safety Systems and throughout Chapter 9 but is not defined. The term “fire protection system” is defined; however, “life safety system” is not. In addition, a new Section 901.4.3, Alterations in Buildings and Structures has also been proposed to address alterations in buildings and structures that is currently located within existing Section 901.4, Installation, which we believe is an incorrect location for this subject matter, therefore a new Section was created.

Cost Impact

The code change proposal will not increase or decrease the cost of construction .

The revisions to this section should not increase or decrease the cost of construction as it is simply to align the text with the title of the chapter and place provisions related to alterations independent of installations.

Internal ID: 1866

F98-18

IFC: 901.1, 901.5, 901.6

Proponent: Jeffrey Shapiro, representing Self (jeff.shapiro@intlcodeconsultants.com)

2018 International Fire Code

Revise as follows:

901.1 Scope. The provisions of this chapter shall specify where fire protection and life safety systems and equipment are required and shall apply to the design, installation, inspection, operation, testing and maintenance of all ~~fire protection systems~~ such systems and equipment.

901.5 Installation acceptance testing. Fire detection and alarm systems, emergency alarm systems, gas detection systems, fire-extinguishing systems, fire hydrant systems, ~~fire~~ standpipe systems, fire pump systems, private fire service mains ~~and all other~~, mechanical smoke exhaust systems, smoke and heat vents, and other fire protection systems and appurtenances thereto shall be subject to acceptance tests as contained in the installation standards and as *approved* by the *fire code official*. The *fire code official* shall be notified before any required acceptance testing.

901.6 Inspection, testing and maintenance. Fire detection and alarm systems, emergency alarm systems, gas detection systems, fire-extinguishing systems, fire hydrant systems, standpipe systems, fire pump systems, private fire service mains, mechanical smoke exhaust systems ~~and~~, smoke and heat vents, and other fire protection systems and appurtenances thereto shall be maintained in an operative condition at all times, and shall be replaced or repaired where defective. Nonrequired *fire protection systems* and equipment shall be inspected, tested and maintained or removed.

Reason:

Cleanup to correlate with systems and equipment covered in Chapter 9 that have been omitted from scoping and ITM sections. And, for 901.6, to 901.5 correlate the text with Section 901.5 and vice versa. These sections should have the same scoping.

Cost Impact

The code change proposal will not increase or decrease the cost of construction .

Not anticipated as changing how the code is applied.

Internal ID: 2209

F99-18

IFC: 901.2.1

Proponent: Lynn Nielson, representing Self

2018 International Fire Code

901.2 Construction documents. The *fire code official* shall have the authority to require *construction documents* and calculations for all *fire protection systems* and to require permits be issued for the installation, rehabilitation or modification of any *fire protection system*. *Construction documents for fire protection systems* shall be submitted for review and approval prior to system installation.

Add new text as follows:

901.2.1 Fire protection system plans and calculations. Jurisdictions that review construction documents and perform inspections for fire protection systems shall use qualified personnel, approved agencies or individuals as determined by the fire code official.

Revise as follows:

~~901.2.1~~**901.2.2 Statement of compliance.** Before requesting final approval of the installation, where required by the *fire code official*, the installing contractor shall furnish a written statement to the *fire code official* that the subject *fire protection system* has been installed in accordance with *approved* plans and has been tested in accordance with the manufacturer's specifications and the appropriate installation standard. Any deviations from the design standards shall be noted and copies of the approvals for such deviations shall be attached to the written statement.

Reason:

The review and inspection of fire protection systems is essential to ensure these life safety and property protection systems achieve their desired objectives. Requiring staff (or those designated) to be qualified to perform these reviews and inspections helps achieve this goal. ICC is one example of an agency that provides certification for plans examiners and inspectors that allows them to demonstrate professionalism, knowledge and skill with fire protection systems.

At the Fire Service Membership Council's (FSMC) request, in 2014 ICC developed five certification examinations to assess code officials' professional competence in fire alarm and sprinkler system plan review and inspection.

The FSMC is working on co-branding the program with the Society of Fire Protection Engineers, American Fire Sprinkler Association, National Fire Sprinkler Association and Automatic Fire Alarm Association and the National Institute for Certification in Engineering Technologies (NICET), as stated in the FSMC Annual Report 2016-17.

Cost Impact

The code change proposal will increase the cost of construction .

Additional cost of construction could be incurred if the jurisdiction passes on the cost of education, training and certification or if the jurisdiction identifies more construction document and installation deficiencies as a result of using qualified personnel.

Internal ID: 2303

F100-18

IFC: 901.4.4, 901.5, 901.5.1, 901.6, 901.8

Proponent: Michael O'Brian, Chair, representing FCAC (fcac@iccsafe.org)

2018 International Fire Code

Revise as follows:

901.4.4 Additional fire protection systems. In occupancies of a hazardous nature, where special hazards exist in addition to the normal hazards of the occupancy, or where the *fire code official* determines that access for fire apparatus is unduly difficult, the *fire code official* shall have the authority to require additional ~~safeguards~~. ~~Such safeguards include, but shall not be limited to, the following: automatic fire detection systems, fire alarm systems, automatic fire-extinguishing systems, standpipe systems, or portable or fixed extinguishers.~~ Fire protection equipment ~~safeguards and fire protection systems~~. Fire protection systems required under this section shall be installed in accordance with this code and the applicable referenced standards.

901.5 Installation acceptance testing. ~~Fire detection and alarm systems, emergency alarm systems, gas detection systems, fire-extinguishing systems, fire hydrant systems, fire standpipe systems, fire pump systems, private fire service mains and all other fire~~ *Fire protection systems* and appurtenances thereto shall be subject to acceptance tests as contained in the installation standards and as *approved* by the *fire code official*. The *fire code official* shall be notified before any required acceptance testing.

901.5.1 Occupancy. It shall be unlawful to occupy any portion of a building or structure until the required fire ~~detection, alarm and suppression~~ *protection systems* have been tested and *approved*.

901.6 Inspection, testing and maintenance. ~~Fire detection and alarm systems, emergency alarm systems, gas detection systems, fire-extinguishing systems, mechanical smoke exhaust systems and smoke and heat vents~~ *protection systems* shall be maintained in an operative condition at all times, and shall be replaced or repaired where defective. Nonrequired *fire protection systems* and equipment shall be inspected, tested and maintained or removed in accordance with Section 901.8.

901.8 Removal of or tampering with equipment. It shall be unlawful for any person to remove, tamper with or otherwise disturb any fire ~~hydrant, fire detection and alarm system, fire suppression system or other fire appliance~~ *protection system* required by this code except for the purposes of extinguishing fire, training, recharging or making necessary repairs or where *approved* by the *fire code official*.

Reason:

Section 901.1 through 901.4.3 uses "Fire Protection System" and the remainder of 901 uses a list of multiple systems, many times leaving out sprinkler systems and other types of systems.

This proposal is submitted by the ICC Fire Code Action Committee (FCAC). The FCAC was established by the ICC Board of Directors to pursue opportunities to improve and enhance assigned International Codes with regard to fire safety and hazardous materials in new and existing buildings and facilities and the protection of life and property in wildland urban interface areas. In 2017 the Fire-CAC has held 3 open meetings. In addition, there were numerous conference calls, Regional Work Group and Task Group meetings for the current code development cycle, which included members of the committees as well as any interested parties, to discuss and debate the proposed changes. Related documentation and reports are posted on the FCAC website at: <https://www.iccsafe.org/codes-tech-support/cs/fire-code-action-committee-fcac/>

Cost Impact

The code change proposal will not increase or decrease the cost of construction .

Language clarifies and encompasses all systems that meet the definition. No cost involved.

Internal ID: 190

F101-18

IFC: 901.7

Proponent: John Williams, Chair, representing Healthcare Committee (AHC@iccsafe.org); Michael O'Brian, Chair, representing FCAC (fcac@iccsafe.org)

2018 International Fire Code

Revise as follows:

901.7 Systems out of service. Where a required *fire protection system* is out of service, the fire department and the *fire code official* shall be notified immediately and, where required by the *fire code official*, the building shall be either evacuated or an *approved* fire watch shall be provided for all occupants left unprotected by the shutdown until the *fire protection system* has been returned to service.

Where utilized, fire watches shall be provided with not less than one *approved* means for notification of the fire department and their only duty shall be to perform constant patrols of the protected premises and keep watch for fires.

Exception: Facilities with an approved notification and impairment management procedure complying with NFPA 25 or NFPA 72.

Reason:

The primary purpose of the proposed exception is to address the word “immediately.” In addition to periodic maintenance and testing, the extent of construction activity in existing Group I-2 buildings would result in the fire department and fire code official being constantly notified of fire protection systems being placed out of service and then needing to make a determination as to whether a fire watch or building evacuation are required. In many instances, the duration of the system being out of service is relatively short. For example, a dry pipe sprinkler system is impaired at the conclusion of every trip test for the time period necessary to reset the system.

NFPA 25 and NFPA 72 address these situations and allow either 10 hours in a 24 hour period (NFPA 25) or 4 hours in a 24 hour period (NFPA 72) of time before the building is required to be evacuated or a fire watch is implemented. Both documents still require the fire department, code official, and other parties (such as the insurance carrier) to be notified. The NFPA documents also address issues such as:

Designating an impairment coordinator (NFPA 25)

Responsibilities of the impairment coordinator (NFPA 25)

Tagging system (NFPA 25)

Restoring the system to service and the resultant notifications (Both NFPA 25 and NFPA 72)

Supervising station notification requirements (NFPA 72)

Risk mitigation (NFPA 25 and NFPA 72)

Record keeping (NFPA 25 and NFPA 72)

The list of responsibilities in Sections 901.7.4 and 901.7.6 are essentially the same as the lists in NFPA 25. As such, the primary impact of this change is to establish an acceptable time period prior to establishing the requirement for a fire watch or building evacuation. The established time period also results in uniformity and allows for proper planning when a preplanned impairment is anticipated. It also relieves the code official from being required to establish when a fire watch or building evacuation is required.

This proposal is submitted by the ICC Fire Code Action Committee (FCAC) and the ICC Committee on Healthcare (CHC).

The FCAC was established by the ICC Board of Directors to pursue opportunities to improve and enhance assigned International Codes with regard to fire safety and hazardous materials in new and existing buildings and facilities and the protection of life and property in wildland urban interface areas. In 2017 the Fire-CAC has held 3 open meetings. In addition, there were numerous conference calls, Regional Work Group and Task Group meetings for the current code development cycle, which included members of the committees as well as any interested parties, to discuss and debate the proposed changes. Related documentation and reports are posted on the FCAC website at: <https://www.iccsafe.org/codes-tech-support/cs/fire-code-action-committee-fcac/>.

The CHC was established by the ICC Board to evaluate and assess contemporary code issues relating to healthcare facilities. This is a joint effort between ICC and the American Society for Healthcare Engineering (ASHE), a subsidiary of the American Hospital Association, to eliminate duplication and conflicts in healthcare regulation. In 2017 the CHC held 2 open meetings and numerous conference calls, which included members of the committees as well as any interested parties, to discuss and debate the proposed changes. Information on the CHC, including: meeting agendas; minutes;

reports; resource documents; presentations; and all other materials developed in conjunction with the CHC effort can be downloaded from the CHC website at: <https://www.iccsafe.org/codes-tech-support/cs/icc-committee-on-healthcare/>.

Cost Impact

The code change proposal will not increase or decrease the cost of construction .

This is an operational option with no construction requirements.

Internal ID: 601

F102-18

IFC: 903.2.4, 903.2.4.2 (New) , 903.2.7, 903.2.7.2 (New), 903.2.9, 903.2.9.3 (New) (IBC: [F] 903.2.4, [F]903.2.4.2 (New) , [F]903.2.7, [F]903.2.7.2 (New), [F]903.2.9, [F]903.2.9.3 (New))

Proponent: Michael O'Brian (FCAC@iccsafe.org); Andrew Klein, Self Storage Association (andrew@asklein.com)

2018 International Fire Code

903.1 General. *Automatic sprinkler systems* shall comply with this section.

903.2 Where required. *Approved automatic sprinkler systems* in new buildings and structures shall be provided in the locations described in Sections 903.2.1 through 903.2.12.

Exception: Spaces or areas in telecommunications buildings used exclusively for telecommunications equipment, associated electrical power distribution equipment, batteries and standby engines, provided that those spaces or areas are equipped throughout with an automatic smoke detection system in accordance with Section 907.2 and are separated from the remainder of the building by not less than 1-hour *fire barriers* constructed in accordance with Section 707 of the International Building Code or not less than 2-hour *horizontal assemblies* constructed in accordance with Section 711 of the International Building Code, or both.

Revise as follows:

903.2.4 Group F-1. An *automatic sprinkler system* shall be provided throughout all buildings containing a Group F-1 occupancy where one of the following conditions exists:

1. A Group F-1 *fire area* exceeds 12,000 square feet (1115 m²).
2. A Group F-1 *fire area* is located more than three stories above grade plane.
3. The combined area of all Group F-1 *fire areas* on all floors, including any mezzanines, exceeds 24,000 square feet (2230 m²).
4. ~~A Group F-1 occupancy used for the manufacture of upholstered furniture or mattresses exceeds 2,500 square feet (232 m²).~~

903.2.4.1 Woodworking operations. An *automatic sprinkler system* shall be provided throughout all Group F-1 occupancy *fire areas* that contain woodworking operations in excess of 2,500 square feet (232 m²) in area that generate finely divided combustible waste or use finely divided combustible materials.

Add new text as follows:

903.2.4.2 Group F-1 upholstered furniture or mattresses. An automatic sprinkler system shall be provided throughout a Group F-1 fire area used for the manufacture of upholstered furniture or mattresses that exceeds 2,500 square feet (232 m²).

Revise as follows:

903.2.7 Group M. An *automatic sprinkler system* shall be provided throughout buildings containing a Group M occupancy where one of the following conditions exists:

1. A Group M *fire area* exceeds 12,000 square feet (1115 m²).
2. A Group M *fire area* is located more than three stories above grade plane.
3. The combined area of all Group M *fire areas* on all floors, including any mezzanines, exceeds 24,000 square feet (2230 m²).
4. ~~A Group M occupancy used for the display and sale of upholstered furniture or mattresses exceeds 5,000 square feet (464 m²).~~

Add new text as follows:

903.2.7.2 Group M upholstered furniture or mattresses. An automatic sprinkler system shall be provided throughout a Group M fire area used for the display and sale of upholstered furniture or mattresses that exceeds 5,000 square feet (464 m²).

Revise as follows:

903.2.9 Group S-1. *An automatic sprinkler system shall be provided throughout all buildings containing a Group S-1 occupancy where one of the following conditions exists:*

1. A Group S-1 *fire area* exceeds 12,000 square feet (1115 m²).
2. A Group S-1 *fire area* is located more than three stories above grade plane.
3. The combined area of all Group S-1 *fire areas* on all floors, including any mezzanines, exceeds 24,000 square feet (2230 m²).
4. A Group S-1 *fire area* used for the storage of commercial motor vehicles where the *fire area* exceeds 5,000 square feet (464 m²).
5. ~~A Group S-1 occupancy used for the storage of upholstered furniture or mattresses exceeds 2,500 square feet (232 m²).~~

Add new text as follows:

903.2.9.3 Group S-1 upholstered furniture and mattresses. An automatic sprinkler system shall be provided throughout a Group S-1 fire area used for the storage of upholstered furniture or mattresses that exceeds 2,500 square feet (232 m²).

Exception: Self-service storage facilities (mini-storage) no greater than one story above grade plane where all storage spaces can be accessed directly from the exterior.

Reason:

This proposal addresses a number of issues dealing with the suppression requirements for spaces containing upholstered furniture or mattresses.

The term Occupancy is replaced with fire area to clarify that the target hazard is the space containing the hazard.

The threshold language has been dropped down to its own subsection to provide for suppression being installed only within the target hazard fire area, not the entire building the fire area may be located within.

An exception has been added to the S-1 trigger for one story self-service storage facilities (mini-storage) where all storage spaces can be accessed from the exterior.

This proposal is submitted by the ICC Fire Code Action Committee (FCAC). The FCAC was established by the ICC Board of Directors to pursue opportunities to improve and enhance assigned International Codes with regard to fire safety and hazardous materials in new and existing buildings and facilities and the protection of life and property in wildland urban interface areas. In 2017 the Fire-CAC has held 3 open meetings. In addition, there were numerous conference calls, Regional Work Group and Task Group meetings for the current code development cycle, which included members of the committees as well as any interested parties, to discuss and debate the proposed changes. Related documentation and reports are posted on the FCAC website at: <https://www.iccsafe.org/codes-tech-support/cs/fire-code-action-committee-fcac/>

Cost Impact

The code change proposal will not increase or decrease the cost of construction .

By limiting the fire suppression requirement to the targeted hazard fire area instead of suppressing the whole building, the cost of construction has been reduced.

F103-18

IFC: 903.1.1, 904.2.1 (IBC: [F]903.1.1, [F]904.2.1)

Proponent: Kevin Scott, representing KH Scott & Associates LLC (khscottassoc@gmail.com)

2018 International Fire Code

Revise as follows:

903.1.1 Alternative protection. Alternative automatic fire-extinguishing systems complying with Section 904 shall be permitted instead of automatic sprinkler protection where recognized by the applicable standard and *approved* by the *fire code official*. Where an automatic fire-extinguishing system is provided in lieu of an automatic sprinkler system, the exceptions or reductions allowed for buildings protected throughout with an automatic sprinkler system shall not apply.

904.2.1 Restriction on using automatic sprinkler system exceptions or reductions. ~~Automatic~~ Where an automatic fire-extinguishing systems shall not be considered alternatives for the purposes of system is provided in lieu of an automatic sprinkler system, the exceptions or reductions allowed for *automatic sprinkler systems* or by other requirements of this code buildings protected throughout with an automatic sprinkler system shall not apply.

Reason:

This proposal is intended to correlate these two sections within each code. There is no intended change in code requirements.

The wording in Section 904.2.1 can be confusing, so it is proposed to be revised without any change in application. Essentially, this section states the if an automatic fire-extinguishing is substituted for the fire sprinkler system in a room or area, then the building is not eligible for code modifications based on the building being equipped with a fire sprinkler system. In other words, the building is not considered sprinklered throughout when sprinklers are not provided in all locations where the code and the design standard require sprinklers. Section 903.1.1 is revised to correlate with 904.2.1. This section is revised to clarify application of this section.

Sections 903.1.1 and 904.2 discuss the substitution of alternative fire-extinguishing systems for sprinklers, but the limitation regarding substitution for sprinklers is only found in Section 904.2.1. It is added to Section 903.1.1 so that it is not overlooked.

Cost Impact

The code change proposal will not increase or decrease the cost of construction .

No cost impact since this is simply clarification and correlation between the codes.

Internal ID: 2023

F104-18

IFC: 903.2.3 (IBC: [F] 903.2.3)

Proponent: Randy Roxson, representing USA Sprinkler Fitters Association (randy@roxsonlaw.com)

2018 International Fire Code

Delete and substitute as follows:

903.2.3 Group E. ~~An automatic sprinkler system shall be provided for Group E occupancies as follows:~~

- ~~1. Throughout all Group E fire areas greater than 12,000 square feet (1115 m²) in area.~~
- ~~2. The Group E fire area is located on a floor other than a level of exit discharge serving such occupancies.~~

~~**Exception:** In buildings where every classroom has not fewer than one exterior exit door at ground level, an automatic sprinkler system is not required in any area below the lowest level of exit discharge serving that area.~~

- ~~3. The Group E fire area has an occupant load of 300 or more.~~

903.2.3 Group E. ~~An automatic sprinkler system shall be provided throughout all buildings with a Group E fire area.~~

Reason:

According to statistics compiled by NFPA, fire departments responded to an average of 4,980 structure fires in educational occupancies each year from 2011 until 2015. These fires caused an average of one civilian death, 70 civilians injured, and \$70 million in direct property loss each of those years sampled. Most occurred in K-12 educational occupancies.

Also, there exists a psychological impact upon students whom are instantly confronted with the sudden loss of important rituals such as sporting events and other extracurricular activities, not to mention a disruption to their education.

The square footage or number of occupants of the building have little relationship to the plethora of adverse impacts to life, property and the mutual distress to students and the community when a fire occurs in a school.



FACT SHEET » RESEARCH

Structure Fires in Educational Properties

U.S. fire departments responded to an estimated average of 4,980 structure fires in educational properties in 2011–2015, annually. These fires caused annual averages of one civilian death, 70 civilian injuries, and \$70 million in direct property damage.

Nearly seven in ten of the fires in educational properties (69%) occurred in nursery, elementary, middle, or high schools. The remaining educational property fires were reported in college classrooms and adult education centers (13%), day care centers (11%), or unclassified or unknown education properties (6%).

Structure Fires in Educational Property Type
2011–2015 Annual Averages

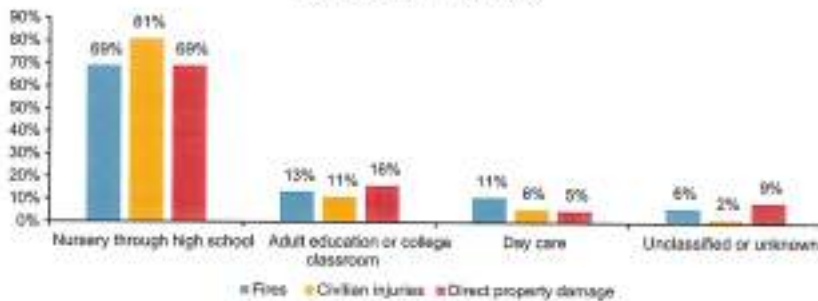

- ▶ In 2011–2015, 38% of structure fires in educational properties involved cooking equipment. These fires resulted in 14% of civilian injuries and 3% of direct property damage.
- ▶ Fires that were set intentionally accounted for 36% of educational property fires. These fires caused 37% of civilian injuries and 31% of direct property damage.
- ▶ Playing with a heat source was responsible for 15% of educational property fires and caused 15% of civilian injuries and 20% of direct property damage.

These estimates are derived from the U.S. Fire Administration National Fire Incident Reporting System (NFIRS) Version 5.0 and NFPA's annual fire department experience survey. Educational property includes preschools through high schools, adult education centers, and day care centers.

Source: NFPA Research: www.nfpa.org/research
Contact information: 617-884-7452 or research@nfpa.org



NATIONAL FIRE PROTECTION ASSOCIATION
The leading information and knowledge resource on fire, electrical and related hazards.

This information is provided to help advance fire safety. It does not represent the official position of the NFPA or its Technical Committees. The NFPA disclaims liability for any personal injury, property, or other damages of any nature whatsoever resulting from the use of this information.

© 2017 National Fire Protection Association • September 2017

Cost Impact

The code change proposal will increase the cost of construction .

The cost versus the benefit of protecting our educational facilities are immeasurable. A school having fewer than 300 students or is 12,000 square feet or less, or having direct exits to the exterior is no less vulnerable to fire and the resulting adverse impacts.

Internal ID: 1137

F105-18

IFC: 903.2.4, 903.2.7, 903.2.9 (IBC: [F]903.2.4, [F]903.2.7, [F]903.2.9)

Proponent: Marcelo Hirschler, GBH International, representing GBH International (gbhint@aol.com)

2018 International Fire Code

Revise as follows:

903.2.4 Group F-1. An *automatic sprinkler system* shall be provided throughout all buildings containing a Group F-1 occupancy where one of the following conditions exists:

1. A Group F-1 *fire area* exceeds 12,000 square feet (1115 m²).
2. A Group F-1 *fire area* is located more than three stories above grade plane.
3. The combined area of all Group F-1 *fire areas* on all floors, including any mezzanines, exceeds 24,000 square feet (2230 m²).
4. A Group F-1 occupancy ~~used for the manufacture of upholstered furniture or mattresses exceeds that is greater than 2,500 square feet (232 m²)~~ in area and where upholstered furniture or mattresses are manufactured.

903.2.7 Group M. An *automatic sprinkler system* shall be provided throughout buildings containing a Group M occupancy where one of the following conditions exists:

1. A Group M *fire area* exceeds 12,000 square feet (1115 m²).
2. A Group M *fire area* is located more than three stories above grade plane.
3. The combined area of all Group M *fire areas* on all floors, including any mezzanines, exceeds 24,000 square feet (2230 m²).
4. A Group M occupancy ~~used for the display and sale of upholstered furniture or mattresses exceeds that is greater than 5,000 square feet (464 m²)~~ in area and that is used for the display or sale of any amount of upholstered furniture or mattresses.

903.2.9 Group S-1. An *automatic sprinkler system* shall be provided throughout all buildings containing a Group S-1 occupancy where one of the following conditions exists:

1. A Group S-1 *fire area* exceeds 12,000 square feet (1115 m²).
2. A Group S-1 *fire area* is located more than three stories above grade plane.
3. The combined area of all Group S-1 *fire areas* on all floors, including any mezzanines, exceeds 24,000 square feet (2230 m²).
4. A Group S-1 *fire area* used for the storage of commercial motor vehicles where the *fire area* exceeds 5,000 square feet (464 m²).
5. A Group S-1 occupancy ~~used for the storage of upholstered furniture or mattresses exceeds that is greater than 2,500 square feet (232 m²)~~ in area and is used for the storage of any amount of upholstered furniture or mattresses.

Reason:

Change proposed simply to clarify the meaning of the existing section. No requirements are being altered but questions have been raised as to how the requirements should be applied.

Cost Impact

The code change proposal will not increase or decrease the cost of construction .

No change because the code proposal is simply clarification.

Internal ID: 151

F106-18

IFC: 903.2.7, 903.2.9 (IBC: [F] 903.2.7, [F] 903.2.9)

Proponent: Ellie Klausbruckner, Klausbruckner & Associates Inc., representing Klausbruckner & Associates, Inc. (ek@klausbruckner.com)

2018 International Fire Code

Revise as follows:

903.2.7 Group M. An *automatic sprinkler system* shall be provided throughout buildings containing a Group M occupancy where one of the following conditions exists:

1. A Group M *fire area* exceeds 12,000 square feet (1115 m²).
2. A Group M *fire area* is located more than three stories above grade plane.
3. The combined area of all Group M *fire areas* on all floors, including any mezzanines, exceeds 24,000 square feet (2230 m²).
4. A Group M occupancy where the area used for the display and sale of upholstered furniture or mattresses exceeds 5,000 square feet (464 m²).

903.2.9 Group S-1. An *automatic sprinkler system* shall be provided throughout all buildings containing a Group S-1 occupancy where one of the following conditions exists:

1. A Group S-1 *fire area* exceeds 12,000 square feet (1115 m²).
2. A Group S-1 *fire area* is located more than three stories above grade plane.
3. The combined area of all Group S-1 *fire areas* on all floors, including any mezzanines, exceeds 24,000 square feet (2230 m²).
4. A Group S-1 *fire area* used for the storage of commercial motor vehicles where the *fire area* exceeds 5,000 square feet (464 m²).
5. A Group S-1 occupancy where the area used for the storage of upholstered furniture or mattresses exceeds 2,500 square feet (232 m²).

Reason:

In a lot of retail or storage areas there may be as little as a few upholstered furniture for display or storage. These sections imply if the area of the display or storage of upholstered furniture is even 10 sq ft and this display is located in a very large room/building, that the entire room/building needs to be sprinklered. We do not believe this was the intent of this section.

Cost Impact

The code change proposal will decrease the cost of construction .

This is intended to clarify that the area of the upholstered display or storage and not the entire room needs to be considered. A lot of businesses having small number of upholstered furniture will not longer be "lumped" together with facilities that are of actual concern.

Internal ID: 1625

F107-18

IFC: 903.2.9 (IBC: [F] 903.2.9)

Proponent: Bob Morgan, Fort Worth Fire Department, representing Fort Worth Fire Department

2018 International Fire Code

Revise as follows:

903.2.9 Group S-1. An *automatic sprinkler system* shall be provided throughout all buildings containing a Group S-1 occupancy where one of the following conditions exists:

1. A Group S-1 *fire area* exceeds 12,000 square feet (1115 m²).
2. A Group S-1 *fire area* is located more than three stories above grade plane.
3. The combined area of all Group S-1 *fire areas* on all floors, including any mezzanines, exceeds 24,000 square feet (2230 m²).
4. A Group S-1 *fire area* used for the storage of commercial motor vehicles where the *fire area* exceeds 5,000 square feet (464 m²).
5. A Group S-1 ~~occupancy~~ *fire area* used for the storage of upholstered furniture or mattresses exceeds 2,500 square feet (232 m²).
6. A Group S-1 *fire area* used as a public- or self-storage facility exceeds 2,500 square feet (232 m²).

Reason:

Correction proposed for consistency of requirements relative to occupancy vs fire area. Additional requirement proposed to sprinkler public- and self-storage facilities, which regularly store a multitude of different commodities, not the least concerning of which is upholstered furniture. The fire area criteria allows for fire barriers to be utilized to separate the different spaces up to the aggregate 24,000sq. ft.

Cost Impact

The code change proposal will increase the cost of construction .

The requirement for sprinkler protection of such occupancies or the provision of fire barriers to avoid such requirement will increase the cost of construction.

Internal ID: 1292

F108-18

IFC: 903.2.9 (IBC: [F]903.2.9)

Proponent: Ellie Klausbruckner, Klausbruckner & Associates Inc., representing Klausbruckner & Associates, Inc. (ek@klausbruckner.com)

2018 International Fire Code

Add new text as follows:

903.2.9 Group S-1. An *automatic sprinkler system* shall be provided throughout all buildings containing a Group S-1 occupancy where one of the following conditions exists:

1. A Group S-1 *fire area* exceeds 12,000 square feet (1115 m²).
2. A Group S-1 *fire area* is located more than three stories above grade plane.
3. The combined area of all Group S-1 *fire areas* on all floors, including any mezzanines, exceeds 24,000 square feet (2230 m²).
4. A Group S-1 *fire area* used for the storage of commercial motor vehicles where the *fire area* exceeds 5,000 square feet (464 m²).
5. A Group S-1 occupancy used for the storage of upholstered furniture or mattresses exceeds 2,500 square feet (232 m²).

Exception: Self-service storage facilities.

Reason:

The proposed code change was intended for occupancies dedicated to storage of upholstered furniture and mattresses and this will reduce the need to sprinkler occupancies not intended.

Cost Impact

The code change proposal will decrease the cost of construction .

This code exception is intended exclude the application of 2500 sq ft as a sprinkler threshold in self storage areas that are not specifically dedicated for storage of upholstered furniture,.

Internal ID: 1783

F109-18

IFC: 903.2.9 (IBC: [F]903.2.9)

Proponent: Mark Chubb, representing Telgian Corp. (mchubb@telgian.com)

2018 International Fire Code

Revise as follows:

903.2.9 Group S-1. An *automatic sprinkler system* shall be provided throughout all buildings containing a Group S-1 occupancy where one of the following conditions exists:

1. A Group S-1 *fire area* exceeds 12,000 square feet (1115 m²).
2. A Group S-1 *fire area* is located more than three stories above grade plane.
3. The combined area of all Group S-1 *fire areas* on all floors, including any mezzanines, exceeds 24,000 square feet (2230 m²).
4. A Group S-1 *fire area* used for the storage of commercial motor vehicles where the *fire area* exceeds 5,000 square feet (464 m²); ~~excluding noncombustible canopies and open structures.~~
5. A Group S-1 occupancy used for the storage of upholstered furniture or mattresses exceeds 2,500 square feet (232 m²).

Reason:

The proponent has recently encountered jurisdictions requiring the installation of automatic sprinkler systems under canopies and open structures protecting motor fuel dispensing operations with five or more dispensing islands (10 vehicle bays). Existing safeguards for motor fuel dispensing operations prescribed by Chapter 23 adequately address this hazard.

Cost Impact

The code change proposal will not increase or decrease the cost of construction .

The proposed change recognizes the efficacy of existing safeguards prescribed by Chapter 23.

Internal ID: 425

F110-18

IFC: 903.2.10, 903.2.11.3 (IBC: [F]903.2.10, [F]903.2.11.3)

Proponent: Jeffrey Shapiro, representing National Fire Sprinkler Association (jeff.shapiro@intlcodeconsultants.com)

2018 International Fire Code

903.2.10 Group S-2 enclosed parking garages. An automatic sprinkler system shall be provided throughout buildings classified as enclosed parking garages ~~in accordance with Section 406.6 of the International Building Code where either~~ where any of the following conditions exists:

1. Where the fire area of the enclosed parking garage in accordance with Section 406.6 of the International Building Code exceeds 12,000 square feet (1115 m²).
2. Where the enclosed parking garage in accordance with Section 406.6 of the International Building Code is located beneath other groups.

Exception: Enclosed parking garages located beneath Group R-3 occupancies.

3. Where the fire area of the open parking garage in accordance with Section 406.5 of the International Building Code exceeds 48,000 square feet (4460 m²).

903.2.11.3 Buildings 55 feet or more in height. An automatic sprinkler system shall be installed throughout buildings that have one or more stories with an occupant load of 30 or more located 55 feet (16 764 mm) or more above the lowest level of fire department vehicle access, measured to the finished floor.

Exception:Exceptions:

1. Open parking structures.
2. Occupancies in Group F-2.

Reason:

Historically, open parking garages have been considered to have a very low fire risk, which has led to dozens of special allowances for reduced code requirements in these occupancies. Fire tests run decades ago offered some support for this perspective. However, it is common knowledge that much of what makes up a vehicle today is combustible, and bodies and interior components that may previously have been of steel are now primarily plastic, rubber, fiberglass and lightweight metals, facilitating vehicle-to-vehicle fire spread and production of dense combustible smoke layers. Stored energy systems in electric vehicles also increase the fuel load. Nevertheless, the wisdom of exempting open parking garages from many code requirements that would otherwise apply has tended to go unchallenged, lacking sufficient evidence to demonstrate the existence of a problem. That has now changed.

An open parking garage fire in Liverpool UK on January 1, 2018 demonstrated the fire risk associated with the new world order of vehicle construction. The concrete building and 1,400 cars were destroyed by a fire that reportedly started in a single vehicle's engine compartment.

The thought that allowing smoke to escape from an open parking garage perimeter will entirely mitigate fire risk is certainly debunked by this incident, and this proposal seeks to recognize that these structures and their contents can present significant challenges to the fire service and result in catastrophic fire losses. The recommended sprinkler threshold based on building height is consistent with the threshold that was established years ago for most occupancies, and the reason for exempting open parking garages is no longer evident. The proposal also provides for an area based threshold, which is very generous compared to other occupancies that might be argued as having similar, or even lesser, fire loads. The recommended value is four times larger than what is applicable to enclosed garages, recognizing that, while there may be some benefit to perimeter openings, the fire service will ultimately be relied on to control these fires if sprinklers are not provided. Therefore, it is appropriate to limit the size of a fire area in these building so that there is a reasonable ability of the fire service to access and extinguish a fire before it becomes uncontrollable.



Cost Impact

The code change proposal will increase the cost of construction .

Yes, there is a cost increase due to lowering the thresholds for requiring an automatic sprinkler system in larger and taller open parking garages.

F111-18

IFC: 903.2.11, 903.2.11.7 (New) (IBC: [F]903.2.11, [F] 903.2.11.7 (New))

Proponent: Thomas Daly, The Hospitality Security Consulting Group, LLC, representing The Hospitality Security Consulting Group, LLC (Thomas.Daly@myhscg.com)

2018 International Fire Code

Revise as follows:

903.2.11 Specific buildings areas and hazards. In all occupancies other than Group U, an *automatic sprinkler system* shall be installed for building design or hazards in the locations set forth in Sections 903.2.11.1 through ~~903.2.11.6~~ 903.2.11.7.

Add new text as follows:

903.2.11.7 Exposure protection. Newly constructed buildings of Type III, IV & V construction in 'High' or 'Extreme' wildfire hazard zones, as defined in Section 502.1 of the International Wildland Urban Interface Code, that are otherwise required to have an automatic sprinkler system installed throughout, shall be provided with exposure sprinklers at the exterior perimeter of the building in accordance with the applicable installation standard.

Reason:

Dozens of otherwise fully sprinklered buildings burned to the ground in the October 2017 Napa and Sonoma County, California wildfires as the direct result of exposure to wildfires.

NFPA 13, see Sections 7.7; 8.3.4.3 and 11.3.2 provides sufficient guidance on the design parameters for exposure sprinkler system design which will mitigate the effect of exposure fires on such buildings.

Bibliography:

See NFPA 13-2016 edition for references to exposure sprinkler protection.

Cost Impact

The code change proposal will increase the cost of construction .

This proposed code change will marginally increase the cost of construction but only for newly constructed buildings otherwise requiring sprinkler systems and then only for Type III, IV & V construction types when located within High or Extreme wildfire hazard zones. The number of such buildings will be small but the protection afforded will mitigate the potential for destruction from exposure fires.

Internal ID: 215

F112-18

IFC: 101.2, 202, 311.2.2, 509.1, 509.2, 903.2.11.6 (IBC: [F]903.2.11.6), TABLE 903.2.11.6, 907.6.4.2(IBC: [F]907.6.4.2), 914.2.4 1205.12, 3201.3, 3504.3.1, 5005.1.8, 5704.3.5.1, 5704.3.7.5.1 IBC: [F]402.7.5

Proponent: Michael O'Brian, Chair, representing FCAC (fcac@iccsafe.org)

2018 International Fire Code

[A] 101.2 Scope. This code establishes regulations affecting or relating to structures, processes, premises and safeguards regarding all of the following:

1. The hazard of fire and explosion arising from the storage, handling or use of structures, materials or devices.
2. Conditions hazardous to life, property or public welfare in the occupancy of structures or premises.
3. Fire hazards in the structure or on the premises from occupancy or operation.
4. Matters related to the construction, extension, repair, alteration or removal of fire ~~suppression or alarm~~ protection systems.
5. Conditions affecting the safety of fire fighters and emergency responders during emergency operations.

SUPERVISORY SERVICE. The service required to monitor performance of guard tours and the operative condition of ~~fixed suppression~~ fire protection systems or other systems for the protection of life and property.

SUPERVISORY SIGNAL. A signal indicating the need of action in connection with the supervision of guard tours, the fire ~~suppression~~ protection systems or equipment, or the maintenance features of related systems.

SUPERVISORY SIGNAL-INITIATING DEVICE. An initiating device such as a valve supervisory switch, water level indicator, or low-air pressure switch on a dry-pipe sprinkler system whose change of state signals an off-normal condition and its restoration to normal of a fire protection or life safety system; or a need for action in connection with guard tours, fire ~~suppression~~ protection systems or equipment, or maintenance features of related systems.

311.2.2 Fire protection. Fire ~~alarm, sprinkler and stand pipe~~ protection systems shall be maintained in an operable condition at all times.

Exceptions:

1. Where the premises have been cleared of all combustible materials and debris and, in the opinion of the *fire code official*, the type of construction, *fire separation distance* and security of the premises do not create a fire hazard.
2. Where *approved* by the *fire code official*, buildings that will not be heated and where *fire protection systems* will be exposed to freezing temperatures, fire alarm and automatic sprinkler systems are permitted to be placed out of service and standpipes are permitted to be maintained as dry systems (without an automatic water supply), provided that the building does not have contents or storage, and windows, doors and other openings are secured to prohibit entry by unauthorized persons.
3. Where *approved* by the *fire code official*, fire alarm and automatic sprinkler systems are permitted to be placed out of service in seasonally occupied buildings: that will not be heated; where fire protection systems will be exposed to freezing temperatures; where *fire areas* do not exceed 12,000 square feet (1115 m²); and that do not store motor vehicles or hazardous materials.

509.1 Identification. Fire protection equipment shall be identified in an *approved* manner. Rooms containing controls for air-conditioning systems, ~~sprinkler risers and valves, or other fire detection, suppression or control elements~~ fire protection systems shall be identified for the use of the fire department. *Approved* signs required to identify fire protection system equipment and equipment location shall be constructed of durable materials, permanently installed and readily visible.

509.2 Equipment access. *Approved* access shall be provided and maintained for all fire protection system equipment to permit immediate safe operation and maintenance of such equipment. Storage, trash and other materials or objects shall not be placed or kept in such a manner that would prevent such equipment from being readily

accessible.

903.2.11.6 Other required ~~suppression fire protection systems~~. In addition to the requirements of Section 903.2, the provisions indicated in Table 903.2.11.6 require the installation of a fire ~~suppression protection system~~ for certain buildings and areas.

**TABLE 903.2.11.6
ADDITIONAL REQUIRED FIRE SUPPRESSION PROTECTION SYSTEMS**

SECTION	SUBJECT
914.2.1	Covered and open mall buildings
914.3.1	High-rise buildings
914.4.1	Atriums
914.5.1	Underground structures
914.6.1	Stages
914.7.1	Special amusement buildings
914.8.2	Airport traffic control towers
914.8.3, 914.8.6	Aircraft hangars
914.9	Flammable finishes
914.10	Drying rooms
914.11.1	Ambulatory care facilities
1029.6.2.3	Smoke-protected assembly seating
1103.5.1	Existing Group A occupancies
1103.5.2	Pyroxylin plastic storage in existing buildings
1103.5.3	Existing Group I-2 occupancies
1103.5.4	Existing Group I-2, Condition 2 occupancies
1103.5.4	Pyroxylin plastics
2108.2	Dry cleaning plants
2108.3	Dry cleaning machines
2309.3.2.6.2	Hydrogen motor fuel-dispensing area canopies
2404.2	Spray finishing in Group A, E, I or R
2404.4	Spray booths and spray rooms
2405.2	Dip-tank rooms in Group A, I or R
2405.4.1	Dip tanks
2405.9.4	Hardening and tempering tanks
2703.10	HPM facilities
2703.10.1.1	HPM work station exhaust
2703.10.2	HPM gas cabinets and exhausted enclosures
2703.10.3	HPM exit access corridor
2703.10.4	HPM exhaust ducts
2703.10.4.1	HPM noncombustible ducts
2703.10.4.2	HPM combustible ducts
2807.3	Lumber production conveyor enclosures
2808.7	Recycling facility conveyor enclosures
3006.1	Class A and B ovens
3006.2	Class C and D ovens
Table 3206.2	Storage fire protection
3206.4	Storage
3704.5	Storage of more than 1,000 cubic feet of loose combustible fibers
5003.8.4.1	Gas rooms
5003.8.5.3	Exhausted enclosures
5004.5	Indoor storage of hazardous materials
5005.1.8	Indoor dispensing of hazardous materials
5104.4.1	Aerosol product warehouses
5106.3.2	Aerosol display and merchandising areas
5306.2.1	Exterior medical gas storage room

5306.2.2	Interior medical gas storage room
5306.2.3	Medical gas storage cabinet
5606.5.2.1	Storage of smokeless propellant
5606.5.2.3	Storage of small arms primers
5704.3.7.5.1	Flammable and combustible liquid storage rooms
5704.3.8.4	Flammable and combustible liquid storage warehouses
5705.3.7.3	Flammable and combustible liquid Group H-2 or H-3 areas
6004.1.2	Gas cabinets for highly toxic and toxic gas
6004.1.3	Exhausted enclosures for highly toxic and toxic gas
6004.2.2.6	Gas rooms for highly toxic and toxic gas
6004.3.3	Outdoor storage for highly toxic and toxic gas
6504.1.1	Pyroxylin plastic storage cabinets
6504.1.3	Pyroxylin plastic storage vaults
6504.2	Pyroxylin plastic storage and manufacturing

For SI: 1 cubic foot = 0.023 m³.

907.6.4.2 High-rise buildings. In high-rise buildings, a separate zone by floor shall be provided for each of the following types of alarm-initiating devices where provided:

1. Smoke detectors.
2. Sprinkler waterflow devices.
3. Manual fire alarm boxes.
4. Other *approved* types of automatic fire ~~detection devices or suppression protection systems.~~

914.2.4 Fire department access to equipment. Rooms or areas containing controls for air-conditioning systems, ~~automatic fire-extinguishing systems, automatic sprinkler systems or other detection, suppression or control elements or fire protection systems~~ shall be identified for use by the fire department.

1205.12 Fire suppression protection. ~~Fire suppression protection systems~~ for stationary fuel cell power system installations shall be provided in accordance with NFPA ~~853-853.~~

3201.3 Construction documents. At the time of building permit application for new structures designed to accommodate high-piled storage or for requesting a change of occupancy/use, and at the time of application for a storage permit, plans and specifications shall be submitted for review and approval. In addition to the information required by the International Building Code, the storage permit submittal shall include the information specified in this section. The construction documents shall include all of the following:

1. Floor plan of the building showing locations and dimensions of *high-piled storage areas*.
2. Usable storage height for each storage area.
3. Number of tiers within each rack, if applicable.
4. Commodity clearance between top of storage and the sprinkler deflector for each storage arrangement.
5. Aisle dimensions between each storage array.
6. Maximum pile volume for each storage array.
7. Location and classification of commodities in accordance with Section ~~3203-3203.~~
8. Location of commodities that are banded or encapsulated.
9. Location of required fire department access doors.
10. Type of fire ~~suppression and fire detection protection~~ systems.
11. Location of valves controlling the water supply of ceiling and in-rack sprinklers.
12. Type, location and specifications of smoke removal and curtain board systems.
13. Dimension and location of transverse and longitudinal flue spaces.
14. Additional information regarding required design features, commodities, storage arrangement and fire protection features within the *high-piled storage area* shall be provided at the time of permit, where required by the *fire code official*.

3504.3.1 Pre-hot-work check. A pre-hot-work check shall be conducted prior to work to ensure that all equipment is safe and hazards are recognized and protected. A report of the check shall be kept at the work site during the work and available upon request. The pre-hot-work check shall determine all of the following:

1. *Hot work equipment* to be used shall be in satisfactory operating condition and in good repair.
2. *Hot work* site is clear of combustibles or combustibles are protected.
3. Exposed construction is of noncombustible materials or, if combustible, then protected.
4. Openings are protected.
5. Floors are kept clean.
6. Exposed combustibles are not located on the opposite side of partitions, walls, ceilings or floors.
7. Fire watches, where required, are assigned.
8. *Approved* actions have been taken to prevent accidental activation of ~~suppression and detection~~

fire protection system equipment in accordance with Sections 3504.1.8 and ~~3504.1.9~~3504.1.9.

9. Fire extinguishers and fire hoses (where provided) are operable and available.

Revise as follows:

5005.1.8 Fire ~~extinguishing~~ protection systems. Indoor rooms or areas in which hazardous materials are dispensed or used shall be protected by an automatic sprinkler system or automatic fire-extinguishing system in accordance with Chapter 9. Sprinkler system design shall be not less than that required for Ordinary Hazard, Group 2, with a minimum design area of 3,000 square feet (279 m²). Where the materials or storage arrangement are required by other regulations to be provided with a higher level of sprinkler system protection, the higher level of sprinkler system protection shall be provided.

5704.3.5.1 Basement storage. Class I liquids shall be allowed to be stored in *basements* in amounts not exceeding the *maximum allowable quantity per control area* for use-open systems in Table 5003.1.1(1), provided that ~~automatic suppression and other fire protection systems~~ are provided in accordance with Chapter ~~9-9~~. Class II and IIIA liquids shall be allowed to be stored in *basements*, provided that automatic suppression and other fire protection are provided in accordance with Chapter ~~9-9~~.

5704.3.7.5.1 Fire ~~extinguishing~~ protection systems. Liquid storage rooms shall be protected by *automatic sprinkler systems* installed in accordance with Chapter 9 and Tables 5704.3.6.3(4) through 5704.3.6.3(7) and Table 5704.3.7.5.1. In-rack sprinklers shall also comply with NFPA 13. Automatic foam-water systems and automatic aqueous film-forming foam (AFFF) water sprinkler systems shall not be used except where *approved*.

Protection criteria developed from fire modeling or full-scale fire testing conducted at an *approved* testing laboratory are allowed in lieu of the protection as shown in Tables 5704.3.6.3(2) through 5704.3.6.3(7) and Table 5704.3.7.5.1 where *approved*.

2018 International Building Code

[F] 402.7.5 Fire department access to equipment. Rooms or areas containing controls for air-conditioning systems, ~~automatic fire extinguishing systems, automatic sprinkler systems or other detection, suppression or control elements or fire protection systems~~ shall be identified for use by the fire department.

Reason:

The term suppression is used in several ways throughout the IFC. Suppression is not a defined term, but it means to extinguish the fire or is commonly used as a fire department response term. The IFC uses suppression in ways that are not related to fire extinguishment or fire department response. This proposal adjusts lists, and charging sections to hone in to the intent of the section and replaces with a more exclusive and defined term of fire protection system. A fire protection system is a sprinkler system, an alarm system, a standpipe system and on and on. It is a better term.

This proposal is submitted by the ICC Fire Code Action Committee (FCAC). The FCAC was established by the ICC Board of Directors to pursue opportunities to improve and enhance assigned International Codes with regard to fire safety and hazardous materials in new and existing buildings and facilities and the protection of life and property in wildland urban interface areas. In 2017 the Fire-CAC has held 3 open meetings. In addition, there were numerous conference calls, Regional Work Group and Task Group meetings for the current code development cycle, which included members of the committees as well as any interested parties, to discuss and debate the proposed changes. Related documentation and reports are posted on the FCAC website at: <https://www.iccsafe.org/codes-tech-support/cs/fire-code-action-committee-fcac/>

Cost Impact

The code change proposal will decrease the cost of construction .

Using defined terms in the code will save on mis-interpretation and mis-application of the code.

Internal ID: 195

F113-18

IFC: 903.3.1.1.1 (IBC: [F] 903.3.1.1.1)

Proponent: Bob Morgan, Fort Worth Fire Department, representing Fort Worth Fire Department

2018 International Fire Code

Revise as follows:

903.3.1.1.1 Exempt locations. Automatic sprinklers shall not be required in the following rooms or areas where such rooms or areas are protected with an *approved* automatic fire detection system in accordance with Section 907.2 that will respond to visible or invisible particles of combustion. Sprinklers shall not be omitted from a room merely because it is damp, of fire-resistance-rated construction or contains electrical equipment.

1. A room where the application of water, or flame and water, constitutes a serious life or fire hazard.
2. A room or space where sprinklers are considered undesirable because of the nature of the contents, where *approved* by the *fire code official*.
3. Generator and transformer rooms separated from the remainder of the building by walls and floor/ceiling or roof/ceiling assemblies having a *fire-resistance rating* of not less than 2 hours.
4. Rooms or areas that are of noncombustible construction with wholly noncombustible contents.
5. ~~Fire service access~~ All elevator machine rooms and machinery spaces.
6. ~~Machine rooms, machinery spaces, control rooms and control spaces associated with occupant evacuation elevators designed in accordance with Section 3008 of the International Building Code, control spaces, and hoistways, other than pits.~~

Reason:

It is time to eliminate the shunt trip requirement. NFPA 13 is finally moving in this direction, all be it quite slowly. This is currently only addressed for FSAE and OE elevators. The Fire Department regularly utilizes the elevators in multi-story buildings for emergency operations and subjecting the elevator to shunt trip puts them at risk. Also, if sprinklers are not needed for FSAE and OE equipment areas, etc., why are they needed for other elevators?

Cost Impact

The code change proposal will decrease the cost of construction .

Elimination of the sprinkler requirement from such spaces resulting in the elimination of shunt trip is a cost savings to construction of multi-story buildings.

Internal ID: 924

F114-18

IFC: 903.3.1.1.1 (IBC: [F] 903.3.1.1.1)

Proponent: Bob Morgan, Fort Worth Fire Department, representing Fort Worth Fire Department (bob.morgan@fortworthtexas.gov)

2018 International Fire Code

Revise as follows:

903.3.1.1.1 Exempt locations. Automatic sprinklers shall not be required in the following rooms or areas where such rooms or areas are protected with an *approved* automatic fire detection system in accordance with Section 907.2 that will respond to visible or invisible particles of combustion. Sprinklers shall not be omitted from a room merely because it is damp, of fire-resistance-rated construction or contains electrical equipment.

1. A room where the application of water, or flame and water, constitutes a serious life or fire hazard.
2. A room or space where sprinklers are considered undesirable because of the nature of the contents, where *approved* by the *fire code official*.
3. Generator and transformer rooms separated from the remainder of the building by walls and floor/ceiling or roof/ceiling assemblies having a *fire-resistance rating* of not less than 2 hours.
4. Rooms or areas that are of noncombustible construction with wholly noncombustible contents.
5. Fire service access elevator machine rooms and machinery spaces.
6. Machine rooms, machinery spaces, control rooms and control spaces associated with occupant evacuation elevators designed in accordance with Section 3008 of the International Building Code.
7. Spaces or areas of buildings having molten material present. Such non-sprinklered spaces or areas shall be separated from the remainder of the sprinklered building by walls and floor/ceiling or roof/ceiling assemblies having a fire-resistance rating of not less than 2 hours.

Reason:

OSHA has fined facilities for having fire sprinkler systems in areas having molten material: <https://www.osha.gov/news/newsreleases/region2/08022006>

Although it could be stated that number 1. in the list of sprinkler exemptions addresses this issue, molten material poses such a severe threat to life safety with the provision of fire sprinkler systems overhead, it needs to be specifically addressed here and not subject to interpretation, such as with water reactive materials.

This matter is not well understood in the fire protection industry and is not well addressed by NFPA 13, which only discusses the matter relative to the Standard on Ovens and Furnaces (Section 22.16) and that only requires shielding from sprinkler water and could also be interpreted as only applying to the interior of such appliances.

Guidance is needed for fire sprinkler designers and AHJ's to ensure that this potential life safety threat is avoided.

Bibliography:

1. U.S. Department of Labor: Region 2 News Release: 06-1271-NEW/BOS 2006-213 Wednesday, August 2, 2006 Contact: Ted Fitzgerald Phone: (617) 565-2074
2. NFPA 13 (2016 edition) Section 22.16

Cost Impact

The code change proposal will not increase or decrease the cost of construction .

Although a savings would be incurred from the exemption of the fire sprinkler system from the space/area in question, additional expense would result from the required 2 hour fire separation from the rest of the building. It is not known if this would result in an overall savings or cost increase as a result - will depend upon size of space/area in question and need of separation from surrounding area.

Internal ID: 435

F115-18

IFC: 903.3.1.1.1 (IBC:[F] 903.3.1.1.1)

Proponent: Christopher Athari, Hoover Treated Wood Products, representing Hoover Treated Wood Products (cathari@frtw.com)

2018 International Fire Code

903.3.1.1.1 Exempt locations. Automatic sprinklers shall not be required in the following rooms or areas where such rooms or areas are protected with an *approved* automatic fire detection system in accordance with Section 907.2 that will respond to visible or invisible particles of combustion. Sprinklers shall not be omitted from a room merely because it is damp, of fire-resistance-rated construction or contains electrical equipment.

1. A room where the application of water, or flame and water, constitutes a serious life or fire hazard.
2. A room or space where sprinklers are considered undesirable because of the nature of the contents, where *approved* by the *fire code official*.
3. Generator and transformer rooms separated from the remainder of the building by walls and floor/ceiling or roof/ceiling assemblies having a *fire-resistance rating* of not less than 2 hours.
4. Rooms or areas that are of noncombustible construction with wholly noncombustible contents.
5. Fire service access elevator machine rooms and machinery spaces.
6. Machine rooms, machinery spaces, control rooms and control spaces associated with occupant evacuation elevators designed in accordance with Section 3008 of the International Building Code.
7. Concealed spaces in accordance with NFPA 13, Section 8.15.1.2.

Reason:

This is a clarification needed to ensure the requirements in NFPA 13 are used for buildings constructed under the building code. NFPA recognizes that sprinklers are not necessary in all concealed spaces. Section 8.15.1.2 has the requirements for when sprinklers are not needed.

Cost Impact

The code change proposal will not increase or decrease the cost of construction .

Proposal better explains exemption already allowed in the code.

Internal ID: 871

F116-18

IFC: 903.3.1.1.1 (IBC: [F]903.3.1.1.1)

Proponent: Frank Savino, representing UNITED Fire Protection Corporation (fsavino@ufpco.com)

2018 International Fire Code

Revise as follows:

903.3.1.1.1 Exempt locations. Automatic sprinklers shall not be required in the following rooms or areas where such rooms or areas are protected with an *approved* automatic fire suppression system with a compatible alternative fire suppression agent, actuated by an *approved* fire detection system in accordance with Section 907.2 that will respond to visible or invisible particles of combustion. Sprinklers shall not be omitted from a room merely because it is damp, of fire-resistance-rated construction or contains electrical equipment.

1. A room where the application of water, or flame and water, constitutes a serious life or fire hazard.
2. A room or space where sprinklers are considered undesirable because of the nature of the contents, where *approved* by the *fire code official*.
3. Generator and transformer rooms separated from the remainder of the building by walls and floor/ceiling or roof/ceiling assemblies having a *fire-resistance rating* of not less than 2 hours.
4. Rooms or areas that are of noncombustible construction with wholly noncombustible contents.
5. Fire service access elevator machine rooms and machinery spaces.
6. Machine rooms, machinery spaces, control rooms and control spaces associated with occupant evacuation elevators designed in accordance with Section 3008 of the International Building Code.

Reason:

903.3.1.1.1 of the IBC allows exemption from automatic sprinkler protection for certain locations in buildings that are required to be equipped throughout with an automatic sprinkler system. Exempt locations include generator, transformer, elevator machine rooms and machinery spaces, and control rooms and control spaces associated with occupant evacuation.

The general rationale for the exemption is the incompatibility of water sprinkler discharge with the contents of the room. All of these exempt rooms represent significant risk in terms of probability of fire as well as the consequences from fire.

Simply because one of many possible fire suppression alternatives is not compatible with a hazard should not be a reason to exempt needed protection when many other cost effective alternative agent options are available. These options include water mist, clean waterless agent, aerosol, foam, dry chemical, and carbon dioxide.

In cases where it is the intention of the Code to protect buildings with automatic fire suppression throughout, there should be no exceptions when compatible suppression agent systems are available. The code should require protection with a compatible alternative.

Cost Impact

The code change proposal will increase the cost of construction .

Cost impact is highly dependent on the nature of the protected locations and the chosen alternatives. The additional cost of alternative systems should only be a small fraction of the overall fire protection cost for the entire building.

Internal ID: 1889

F117-18

IFC: 903.3.1.2 (IBC[F] 903.3.1.2)

Proponent: Stephen DiGiovanni, representing self (sdigiovanni@clarkcountynv.gov)

2018 International Fire Code

Revise as follows:

903.3.1.2 NFPA 13R sprinkler systems. *Automatic sprinkler systems* in Group R occupancies ~~up to and including four stories in height in buildings not exceeding 60 feet (18 288 mm) in height above grade plane~~ shall be permitted to be installed throughout in accordance with NFPA ~~13R~~13R ~~where the Group R occupancy meets all of the following conditions:~~

1. Four stories or less above grade plane.
2. The floor level of the highest story is 30 feet (9114 mm) or less above the lowest level of fire department vehicle access.
3. The floor level of the lowest story is 30 feet (9114 mm) or less below the lowest level of fire department vehicle access.

~~The number of stories of Group R occupancies constructed in accordance with Sections 510.2 and 510.4 of the International Building Code shall be measured from the horizontal assembly creating separate buildings grade plane.~~

Reason:

The recent fires in Group R occupancies, both occupied and under construction, requires revisiting the applicable code requirements.

One major concern is the affect of the recent advent of podium-style buildings, and how the code has changed to allow NFPA 13R sprinkler systems to heights that exceed the original scope of NFPA 13R. The scope of NFPA 13R, 2007 edition, reads "This standard shall cover the design and installation of automatic sprinkler systems for protection against fire hazards in residential occupancies up to and including 4 stories in height". In 2013, the scope of NFPA 13R was changed to read "This standard shall cover the design and installation of automatic sprinkler systems for protection against fire in residential occupancies up to and including four stories in height in buildings not exceeding 60 feet (18 m) in height above grade plane."

This followed a change in the 2009 IBC that greatly expanded the use of the podium concept. After the expansion of the podium concept, the increase in height for NFPA 13R systems was permitted, leading us to where we are today. Today, 5 and 6 story height buildings can be created, where the separate podium building is one or two stories (measured from grade plane) and the other separate building, atop the podium building, is 4 stories as measured from the podium, all protected with NFPA 13R fire sprinklers.

There is a big difference in the protection provided between NFPA 13R and NFPA 13 systems, in the required design density and areas covered by fire sprinklers. Allowing the NFPA 13R sprinkler system for these taller podium style buildings leads to a significant decrease in the protection being provided by automatic fire sprinklers, versus what was required prior to the code changes referenced above.

When determining a suitable trigger for height to propose for this code section, a review of other parts of the code led to the requirements for when standpipe systems are required per Section 905.3.1. Philosophically, standpipe systems would be required where travel distance by responding fire fighters is long enough that hose lines fed directly from fire engines may not reach the fire, so that fire hose would need to be carried into the building, for connection to an outlet that is closer to the fire. The decision to trigger the requirement for a standpipe would represent a recognition of an increased building hazard, which in this can be adapted as a means to determine the break point between allowing a NFPA 13R sprinkler system, and requiring a NFPA 13 sprinkler system.

Cost-wise, the infrastructure, such as main pipe sizes, required to install a standpipe system, would ease the impact of requiring the sprinkler system to be NFPA 13, rather than NFPA 13R. While there would be significant argument that the pipe sizes would all have to be increased in order to change from NFPA 13R to NFPA 13, which would clearly increase costs, this increase is tempered by the fact that the pipe sizes required to comply with the standpipe system are so large that the NFPA 13 sprinkler design can very easily be accommodated with little to no increase in pipe sizing. In other words, by using the same requirement for when a standpipe system is required, the impact of requiring a NFPA 13 system, versus 13R, is substantially reduced.

For this reason, the proposal is to use the trigger for installation of a standpipe system, per existing Section 905.3.1, as the upper limit for permitting the installation of NFPA 13R systems, and by default creating the trigger for switching the sprinkler system to a NFPA 13 sprinkler system in Group R occupancies.

In summary, this proposal intends to address the recent fire history in Group R occupancies, especially those built with the podium concept, and seeks to increase the protection required in these buildings. The proposal utilizes the same trigger for requiring a standpipe system, for the point where the sprinkler system would have to change from NFPA 13R design, to NFPA 13 design. While there is still an increase in cost, this increase is greatly minimized due to the already existing requirement for standpipe systems.

Cost Impact

The code change proposal will increase the cost of construction .

This proposal will increase construction costs by requiring NFPA 13 sprinkler systems in some situations where NFPA 13R sprinkler systems are currently permitted. There is no doubt that, due to the difference in water flow required, additional sprinkler requirements, and other requirements in the NFPA standards, that the cost of NFPA 13 sprinkler systems is higher than the cost of NFPA 13R sprinkler systems. Some of this cost is mitigated by aligning the new requirement to the requirement for installing a standpipe system, which already would represent greater flow capacity for the building, ostensibly requiring larger diameter mains already; however, even with this mitigating factor, there is little doubt that this code change would represent an increase in overall construction costs.

Internal ID: 725

F118-18

IBC: 903.3.1.2 (IBC: [F]903.3.1.2)

Proponent: William Hall, Portland Cement Association, representing Alliance For Concrete Codes and Standards (jhall@cement.org); Jason Thompson, representing Masonry Alliance for Codes and Standards (jthompson@ncma.org)

2018 International Fire Code

Revise as follows:

903.3.1.2 NFPA 13R sprinkler systems. *Automatic sprinkler systems* in Group R occupancies up to and including four stories in height in buildings not exceeding 60 feet (18 288 mm) in height above grade plane shall be permitted to be installed throughout in accordance with NFPA 13R.

The number of stories of Group R occupancies constructed in accordance with Sections 510.2 and 510.4 of the International Building Code shall be measured from ~~the horizontal assembly creating separate buildings-grade plane.~~

Reason:

This proposal will restrict the use of NFPA13R to residential structures with a maximum of 4 stories including the podium. Last cycle this issue was somewhat addressed by inserting requirements instructing the user to protect the attic if the highest pitched roof is over 55 ft. at the eaves. However, what if a lower pitched roof is located higher? All of these requirements then would not apply. While these measures increase fire safety in the attic, they do not mitigate the other issues of trying to use a standard out of its scope and the fact remains that combustible concealed areas are still abundant throughout other parts of the building if any of the options are chosen. The Edgewater fire in New Jersey began in a combustible concealed space by workers. Numerous issues such as pressure, volume, height of operations for outside attack become apparent when sorting out the details of how to use the low rise NFPA13R standard for attic protection. Heads in the attic require more water pressure and volume demand than the residential heads within the dwelling units and often may need a fire pump to serve an adequate pressure or volume. NFPA 13R Systems were never designed for property protection and sprinkler protection in the attic is property protection and out of the scope of this standard.

The new sections that were added last cycle are not removed by this proposal. They will still pertain to buildings using the NFPA 13R standard where the building have attics that are greater than 55 ft. to the highest pitch roof, presuming they don't use loophole described above.

Historically our codes have measured to grade plane and podium buildings should be no different. The increased height, possible inset design where the building sits on the podium and modest fire fighting access can make these buildings much tougher to fight if ignition occurs in a concealed area. NFPA 13 systems are the choice to reduce risk and provide life safety and property protection for its residents as well neighboring buildings

Cost Impact

The code change proposal will increase the cost of construction .

While this is the most obvious choice, I cannot say what the cost difference is between modifying NFPA 13R to add sprinklers in the attic and providing a NFPA13 system or using one of the ignition resistant options. It could be less costly but either way, the added cost will be low.

Internal ID: 632

F119-18

IFC: 903.3.1.2.2 (IBC: [F] 903.3.1.2.2)

Proponent: Jeffrey Shapiro, Lake Travis Fire Rescue, representing Lake Travis Fire Rescue (jshapiro@ltfr.org)

2018 International Fire Code

Revise as follows:

903.3.1.2.2 ~~Open-ended corridors~~ Corridors and balconies in the means of egress. Sprinkler protection shall be provided in corridors and for balconies in the means of egress where any of the following conditions apply:

1. Corridors with combustible floor or walls.
2. Corridors with an interior change of direction exceeding 45 degrees (0.79 rad).
3. Corridors that are less than 50 percent open to the outside atmosphere at the ends.
4. Open-ended corridors and associated exterior stairways and ramps as specified in Section 1027.6, Exception 3.
5. Egress balconies not complying with Sections 1021.2 and 1021.3.

Reason:

NFPA 13R has migrated to a place where great liberties are being allowed to exempt corridors in multifamily occupancies from sprinkler requirements, going far beyond what is intended under the IBC. The current text in 13R allows any "open corridor" to be unsprinklered in a 13R protected building, and the NFPA Residential Sprinkler Handbook commentary on Page 296 of the 2016 edition interprets "open" to mean any corridor that is open to outside temperature (regardless of how small the opening may be). Carried to the extreme, an enclosed, unconditioned corridor with an air vent would be permitted by 13R to be an unsprinklered space based on the Handbook and appendix guidance. In contrast, the original allowance by model codes for open corridors to be unsprinklered was associated with breezeway style units that were essentially fully open on one end or both, where the corridor connects to the stairs. In these cases, smoke accumulation in the corridor was inhibited by the large opening.

Recognizing that buildings protected by 13R sprinkler systems gain a variety of sprinkler incentives, for example the IBC allows an exception to providing means of escape openings in 13R protected buildings, the code needs to be put back to a place where the application is better reflective of the original intent. Having been intimately involved in the integration of 13R recognition in the IBC, I can state with absolute certainty that the 13R provisions and guidance are not being interpreted by NFPA in a manner consistent with what the IBC expected.

Although I have prepared a TIA for submittal to 13R hoping to address the issue there as well, I believe that it is essential for the IBC to establish minimum requirements for corridor and balcony protection associated with 13R protected buildings. The text suggested in this proposal is my attempt to get the code back to where it should have been all along.

It is also worth noting that the IBC added requirements for balconies and decks to have sprinkler protection several years ago, based in part on the fire loss history associated with fires originating in these locations. The original loss data associated with NFPA 13R's protection scheme (NFPA 13R Table A.1.2) shows hallways and corridors (recommended for protection by this proposal) as a more frequent area of ignition for fatal fires than exterior balconies and open porches.

For disclosure, I represent the National Fire Sprinkler Association and Tyco Fire Products as a consultant, but I am not representing either on this proposal. I came across this issue in my role as a fire code official, and the proposal is submitted on behalf of my fire department.

Cost Impact

The code change proposal will increase the cost of construction .

Additional sprinklers in corridors and for protection of balconies will add cost.

Internal ID: 1187

F120-18

IFC: 903.3.1.2.3 (IBC: [F]903.3.1.2.3)

Proponent: Jeffrey Shapiro, representing Self (jeff.shapiro@intlcodeconsultants.com)

2018 International Fire Code

Revise as follows:

903.3.1.2.3 Attics. Attic protection shall be provided as follows:

1. Attics that are used or intended for living purposes or storage shall be protected by an *automatic sprinkler system*.
2. Where fuel-fired equipment is installed in an unsprinklered attic, not fewer than one quick-response intermediate temperature sprinkler shall be installed above the equipment.
3. Where located in a building of Type III, Type IV or Type V construction designed in accordance with Section 510.2 or 510.4 of the International Building Code, attics not required by Item 1 to have sprinklers shall comply with one of the following if the roof assembly is located more than 55 feet (16 764 mm) above the lowest level of ~~required~~ fire department vehicle access needed to meet the provisions in Section 503:
 - 3.1. Provide *automatic sprinkler system* protection.
 - 3.2. Construct the attic using noncombustible materials.
 - 3.3. Construct the attic using fire-retardant-treated wood complying with Section 2303.2 of the International Building Code.
 - 3.4. Fill the attic with noncombustible insulation.

The height of the roof assembly shall be determined by measuring the distance from the lowest required fire vehicle access road surface adjacent to the building to the eave of the highest pitched roof, the intersection of the highest roof to the exterior wall, or the top of the highest parapet, whichever yields the greatest distance. For the purpose of this measurement, required fire vehicle access roads shall include only those roads that are necessary for compliance with Section 503.
4. Group R-4, Condition 2 occupancy attics not required by Item 1 to have sprinklers shall comply with one of the following:
 - 4.1. Provide *automatic sprinkler system* protection.
 - 4.2. Provide a heat detection system throughout the attic that is arranged to activate the building fire alarm system.
 - 4.3. Construct the attic using noncombustible materials.
 - 4.4. Construct the attic using fire-retardant-treated wood complying with Section 2303.2 of the International Building Code.
 - 4.5. Fill the attic with noncombustible insulation.

Reason:

When this section was added last cycle, there was some concern about the word "required" when it came to jurisdictions that do not have legal authority to enforce fire code requirements for fire apparatus access roads. Rather than risk possible rejection of the overall requirement, it was agreed that the text would be adjusted in the 2021 cycle to address this concern. While subtle, the intent of this change is to differentiate between access that may be legally required versus access that meets the technical provisions set forth in Section 503.

Cost Impact

The code change proposal will not increase or decrease the cost of construction .

This proposal would only impact jurisdictions that are not enforcing IFC requirements for apparatus access in Section 503, and requiring that a building meet the IFC requirement, regardless of local authority, does not technically constitute a cost increase from ICC's perspective since it relates to local application and enforcement of the code.

Internal ID: 2172

F121-18

IFC: 903.3.1.2.3 (LBC: [F] 903.3.1.2.3)

Proponent: Robert J Davidson, Davidson Code Concepts, LLC, representing Self (rjd@davidsoncodeconcepts.com)

2018 International Fire Code

Revise as follows:

903.3.1.2.3 Attics. Attic protection shall be provided as follows:

1. Attics that are used or intended for living purposes or storage shall be protected by an *automatic sprinkler system*.
2. Where fuel-fired equipment is installed in an unsprinklered attic, not fewer than one quick-response intermediate temperature sprinkler shall be installed above the equipment.
3. Where located in a building of Type III, Type IV or Type V construction ~~designed in accordance with Section 510.2 or 510.4 of the International Building Code~~, attics not required by Item 1 to have sprinklers shall comply with one of the following if the roof assembly is located more than 55 feet (16 764 mm) above the ~~lowest level of required fire department vehicle access grade plane~~:
 - 3.1. Provide *automatic sprinkler system* protection.
 - 3.2. Construct the attic using noncombustible materials.
 - 3.3. Construct the attic using fire-retardant-treated wood complying with Section 2303.2 of the International Building Code.
 - 3.4. Fill the attic with noncombustible insulation.

The height of the roof assembly shall be determined by measuring the distance from the ~~lowest required fire vehicle access road surface adjacent to the building grade plane~~ to the eave of the highest pitched roof, the intersection of the highest roof to the exterior wall, or the top of the highest parapet, whichever yields the greatest distance. ~~For the purpose of this measurement, required fire vehicle access roads shall include only those roads that are necessary for compliance with Section 503.~~

4. Group R-4, Condition 2 occupancy attics not required by Item 1 to have sprinklers shall comply with one of the following:
 - 4.1. Provide *automatic sprinkler system* protection.
 - 4.2. Provide a heat detection system throughout the attic that is arranged to activate the building fire alarm system.
 - 4.3. Construct the attic using noncombustible materials.
 - 4.4. Construct the attic using fire-retardant-treated wood complying with Section 2303.2 of the International Building Code.
 - 4.5. Fill the attic with noncombustible insulation.

Reason:

The purpose of this proposal is to eliminate two triggers contained within the code from last cycles proposal that severely limits application of the necessary improvement to the code requirements dealing with Type III, Type IV or Type V construction building protected by NFPA 13R sprinkler systems. The F172-16 proposal from last cycle's reason statement states:

"This proposal is recommended as a response to fire-service concerns about suppressing a fire involving a tall pedestal building attic. Such attic or attics will be required to have increased fire protection. The proposed threshold is modeled after a combination of two existing code sections, Appendix D Section 105.1 (which establishes requirements for aerial ladder access based on attic height) and Section 903.2.11.3 (which uses 55 feet as a building height threshold related to sprinklers)."

The initial statement is incorrect in that the problem identified, (NFPA 13R protected buildings with concealed combustible space attics being destroyed once a fire reaches the attic), is not limited to tall pedestal buildings. The problem includes buildings not utilizing the pedestal design option. From a fire protection standpoint there is no difference in the fire potential for rapid spread and destruction of the building when a fire reaches an attic 55 feet above the lowest level of fire department access whether or not the building sits upon a pedestal, the fire is still at

that 55 foot level.

The proponent indicates the proposal was developed by combining the concepts found within two code sections, one of those being Section D105.1 which applies to the need for aerial ladder fire apparatus access roads:

"D105.1 Where required. Where the vertical distance between the grade plane and the highest roof surface exceeds 30 feet (9144mm), approved aerial fire apparatus access roads shall be provided. For purposes of this section, the highest roof surface shall be determined by measurement to the eave of a pitched roof, the intersection of the roof to the exterior wall, or the top of parapet walls, whichever is greater."

Note that in Section D105.1 the height is measured from grade plane, (not from a fire apparatus access road), this is important because it is tied to the ability to deploy ground ladders and hand hose streams to combat a fire; and Section D105.1 uses a height of 30 feet which is a concept long contained within the code when assessing the ability to effectively use ground ladders and hand hose lines to combat fire as a trigger for standpipe installations.

This core concept involving the impact of height on the ability to effectively deploy ground ladders and hand hose lines to combat fire do not change based upon the existence of a pedestal. If anything, many pedestal designs negatively impact ground ladder placement where the portion of the building is recessed to the edge of the pedestal. Ground ladders are negatively impacted from placement at a proper climbing angle when placed at grade while simultaneously there may not be sufficient width of the exposed podium from the building face to edge of the podium for ground ladder placement at that level.

This proposal eliminates the reference to pedestal building construction, "designed in accordance with Section 510.2 or Section 510.4 of the International Building Code"; 55 feet above grade is 55 feet above grade regardless of whether or not there is an intervening pedestal. The rapidly spreading fire is 55 feet high and out of reach of effective ground ladder hose stream application.

The proposal also eliminates any reference to a fire vehicle access road. Whether or not there is a "required" fire apparatus access road does not change the impact of the height above grade plane for ground ladder placement.

The reference to "required fire vehicle access roads" was an intentionally restrictive trigger which ensured that the protection, already severely impacted by only applying to pedestal buildings, also only applied to sites with "required fire vehicle access roads". No required access roads, no application of this requirement. Whether or not there is a "required" fire apparatus access road does not change the impact of the height above grade plane for ground ladder placement. In addition, many fire departments are not part of the site design and approval process and do not have authority to require "designated fire apparatus access roads" on an approved site, they must rely on whatever paved areas that have been provided for routine motor vehicle traffic and parking.

Eliminating the two restrictive triggers will ensure that the "solution" added to the code will apply to any building utilizing Type III, Type IV or Type V construction once the height of the roof assembly reaches the 55 foot level above grade plane creating a concealed combustible space attic.

Note: Even with these suggested changes the resulting language will use a height trigger 15 feet higher than the historically recognized 30 feet above grade plane contained within the code dealing with the concept of height versus application of hand hose streams.

Cost Impact

The code change proposal will increase the cost of construction .

This proposal will increase the cost of construction for a portion of buildings that take advantage of pedestal construction combined with wood frame construction measures. This increased is outweighed by the cost of the destruction of buildings constructed in this manner when a fire event reaches the unprotected attic and destroys the entire building.

Internal ID: 2333

F122-18 Part I

IFC: 903.3.2 (IBC: [F] 903.3.2); IFGC: 303.3.1

Proponent: John Williams, Chair, representing Healthcare Committee (AHC@iccsafe.org)

THIS IS A 2 PART CODE CHANGE PROPOSAL. PART I WILL BE HEARD THE IFC COMMITTEE, PART II WILL BE HEARD BY THE IFGC COMMITTEE. PLEASE SEE THE TENTATIVE HEARING ORDERS FOR THE RESPECTIVE COMMITTEES.

2018 International Fire Code

Revise as follows:

903.3.2 Quick-response and residential sprinklers. Where *automatic sprinkler systems* are required by this code, quick-response or residential automatic sprinklers shall be installed in all of the following areas in accordance with Section 903.3.1 and their listings:

1. Throughout all spaces within a smoke compartment containing care recipient *sleeping units* in Group I-2 in accordance with the International Building Code.
2. ~~Throughout all spaces within a smoke compartment containing gas fireplace appliances and decorative gas appliances in Group I-2 in accordance with the International Building Code.~~
3. Throughout all spaces within a smoke compartment containing treatment rooms in ambulatory care facilities.
4. *Dwelling units* and *sleeping units* in Group I-1 and R occupancies.
5. Light-hazard occupancies as defined in NFPA 13.

Internal ID: 635

F122-18 Part II

IFGC: 303.3.1

Proponent: John Williams, Chair, representing Healthcare Committee (AHC@iccsafe.org)

2018 International Fuel Gas Code

Revise as follows:

303.3.1 Fireplaces and decorative appliances in Group I-2, Condition 2 occupancies. ~~Gas in Group I-2, Condition 2 occupancies, gas fireplace appliances and decorative gas appliances shall be prohibited in Group I-2, Condition 2 occupancies except where such appliances are direct-vent appliances installed in public lobby and waiting areas that are not within smoke compartments containing patient sleeping areas. The In Group I-2, Condition 1 occupancies, gas fireplace appliances and decorative gas appliances shall be prohibited in patient sleeping rooms. In Group I-2 occupancies, the appliance controls shall be located where they can be accessed only by facility staff. Such fireplaces shall comply with Sections 501.2 and 604.1 of this code and Section 915 of the International Fire Code.~~

Reason:

This change adds a requirement for quick response sprinkler heads within the smoke compartment where gas fireplace appliances and decorative gas appliances are installed in all Group I-2 facilities (K524). The second part of this change adds the prohibition of installing gas fireplace appliances and decorative gas appliances in nursing home patient rooms. Due to the defend-in-place practice within these building types prohibiting gas fireplace appliances and decorative gas appliances in nursing home patient rooms and requiring quick response sprinklers in the smoke compartment where a gas fireplace appliances and decorative gas appliances is installed will provide the necessary protection for patients, staff and visitors.

This proposal is submitted by the ICC Committee on Healthcare (CHC). The CHC was established by the ICC Board to evaluate and assess contemporary code issues relating to healthcare facilities. This is a joint effort between ICC and the American Society for Healthcare Engineering (ASHE), a subsidiary of the American Hospital Association, to eliminate duplication and conflicts in healthcare regulation. In 2017 the CHC held 2 open meetings and numerous conference calls, which included members of the committees as well as any interested parties, to discuss and debate the proposed changes. Information on the CHC, including: meeting agendas; minutes; reports; resource documents; presentations; and all other materials developed in conjunction with the CHC effort can be downloaded from the CHC website at: <https://www.iccsafe.org/codes-tech-support/cs/icc-committee-on-healthcare/>.

Cost Impact

The code change proposal will not increase or decrease the cost of construction .

The cost will not be impacted because in new construction since all Group I-2 facilities are required to be fully sprinklered.

Internal ID: 3505

F123-18

IFC: 903.4, 903.4.1 (IBC: [F]903.4, [F]903.4.1); IEBC: 803.2.4

Proponent: Michael O'Brian, Chair, representing FCAC (fcac@iccsafe.org)

2018 International Fire Code

Revise as follows:

903.4 Sprinkler system supervision and alarms. Valves controlling the water supply for *automatic sprinkler systems*, pumps, tanks, water levels and temperatures, critical air pressures and waterflow switches on all sprinkler systems shall be electrically supervised by a *listed* fire alarm control unit.

Exceptions:

1. *Automatic sprinkler systems* protecting one- and two-family *dwelling*s.
2. Limited area sprinkler systems in accordance with Section 903.3.8.
3. *Automatic sprinkler systems* installed in accordance with NFPA 13R where a common supply main is used to supply both domestic water and the *automatic sprinkler system*, and a separate shutoff valve for the *automatic sprinkler system* is not provided.
4. Jockey pump control valves that are sealed or locked in the open position.
5. Control valves to commercial kitchen hoods, paint spray booths or dip tanks that are sealed or locked in the open position.
6. Valves controlling the fuel supply to fire pump engines that are sealed or locked in the open position.
7. Trim valves to pressure switches in dry, preaction and deluge sprinkler systems that are sealed or locked in the open position.
8. Underground key or hub gate valves in roadway boxes.

903.4.1 Monitoring. Alarm, supervisory and trouble signals shall be distinctly different and shall be automatically transmitted to an *approved* supervising station or, where *approved* by the *fire code official*, shall sound an audible signal at a constantly attended location.

Exceptions ~~Exception~~:

- ~~1. Underground key or hub valves in roadway boxes provided by the municipality or public utility are not required to be monitored.~~
- ~~2.1~~ Backflow prevention device test valves located in limited area sprinkler system supply piping shall be locked in the open position. In occupancies required to be equipped with a fire alarm system, the backflow preventer valves shall be electrically supervised by a tamper switch installed in accordance with NFPA 72 and separately annunciated.

2018 International Existing Building Code

Revise as follows:

803.2.4 Supervision. Fire sprinkler systems required by this section shall be supervised by one of the following methods:

1. *Approved* central station system in accordance with NFPA 72.
2. *Approved* proprietary system in accordance with NFPA 72.
3. *Approved* remote station system of the jurisdiction in accordance with NFPA 72.
4. Where *approved* by the *code official*, *approved* local alarm service that will cause the sounding of an alarm in accordance with NFPA 72.

Exception: Supervision is not required for the following:

1. Underground ~~gate valve with~~ key or hub gate valves in roadway boxes.
2. Halogenated extinguishing systems.
3. Carbon dioxide extinguishing systems.

4. Dry- and wet-chemical extinguishing systems.
5. Automatic sprinkler systems installed in accordance with NFPA 13R where a common supply main is used to supply both domestic and automatic sprinkler systems and a separate shutoff valve for the automatic sprinkler system is not provided.

Reason:

This change correlates the underground gate valves of fire protection systems in the IBC, IFC, and IEBC. It removes the monitoring requirement to private underground gate valves and places it in the supervision exceptions. The result: underground gate valves with specials keys are not required to be supervised or monitored. Per 2015 IFC Commentary for 903.4.1: "Exception 1 recognizes that underground key or hub valves in roadway boxes are not normally supervised or required to be supervised by this section or NFPA 13."

These requirements have been in the IBC since the first edition in 2000 and it appears to come from the earlier editions of the BOCA code. A strict reading of Section 903.4 appears that a private roadbox would be required to be supervised because the specific language says it has to be monitored, however, the actual code path and information contained in the IBC, IFC, the commentary, NFPA 13, NFPA 24 and NFPA 25 suggests a different intent. The IFC references NFPA 24 (via IFC 507.2.1) for installation of private service mains. In NFPA 24, Section 6.7.3, does not require supervision of underground roadway gate valves, regardless of ownership. If there is no supervision, there certainly cannot be monitoring of a missing device. Furthermore, an informal survey of code officials and supervision device manufacturers reveal no enforcement of this section as it is written and the market lacks devices available to achieve this requirement.

This proposal is submitted by the ICC Fire Code Action Committee (FCAC). The FCAC was established by the ICC Board of Directors to pursue opportunities to improve and enhance assigned International Codes with regard to fire safety and hazardous materials in new and existing buildings and facilities and the protection of life and property in wildland urban interface areas. In 2017 the Fire-CAC has held 3 open meetings. In addition, there were numerous conference calls, Regional Work Group and Task Group meetings for the current code development cycle, which included members of the committees as well as any interested parties, to discuss and debate the proposed changes. Related documentation and reports are posted on the FCAC website at: <https://www.iccsafe.org/codes-tech-support/cs/fire-code-action-committee-fcac/>

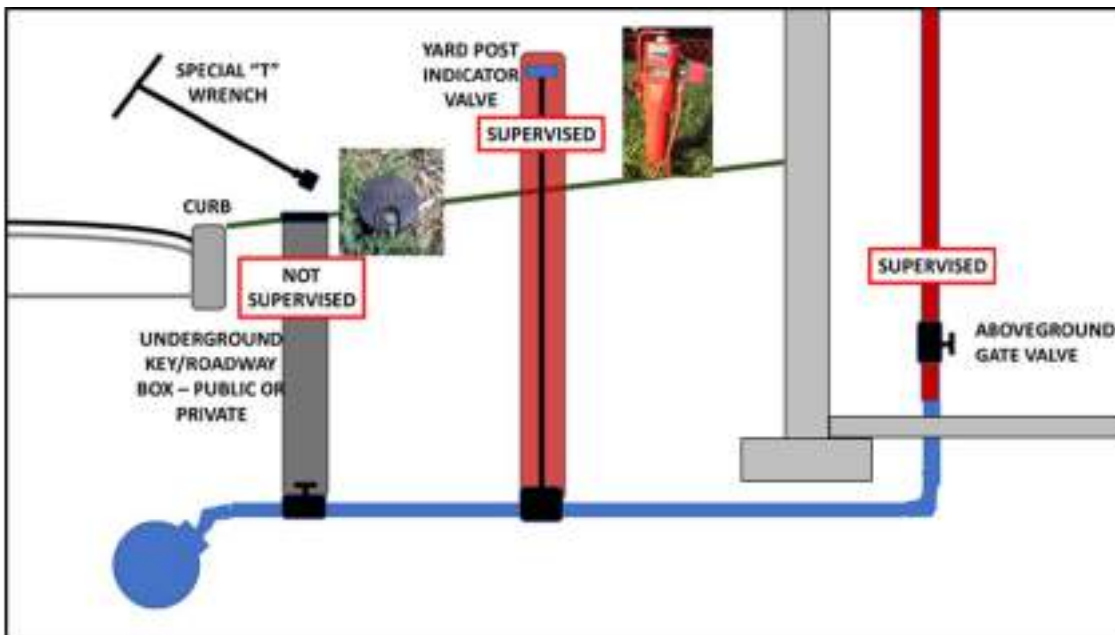

Cost Impact

The code change proposal will not increase or decrease the cost of construction .

The code is unenforceable as written.

Internal ID: 184

F124-18

IFC: 904.14 (IBC: [F]904.14), 904.14.1

Proponent: Kevin Scott, representing KH Scott & Associates LLC (khscottassoc@gmail.com)

2018 International Fire Code

Revise as follows:

~~904.14~~ ~~904.12~~ **Aerosol fire-extinguishing systems.** Aerosol fire-extinguishing systems shall be installed, maintained, periodically inspected ~~, and tested and maintained~~ in accordance with ~~Sections 901 and 904.4~~, NFPA 2010, and ~~in accordance with their listing.~~

Such devices and appurtenances shall be listed and installed in compliance with manufacturer's instructions.

~~904.14.1~~ ~~904.12.1~~ **Maintenance.** Not less than semiannually, an inspection shall be conducted by a trained person to assess whether the system is in working order. Not less than annually, a certified fire suppression contractor having knowledge of and training in the installation, operation and maintenance of the specific fire-extinguishing system shall inspect, test, service and maintain such system in accordance with this section and the manufacturer's specifications and servicing manuals. Records of inspections and testing shall be maintained.

Reason:

Section 904.14 for aerosol fire-extinguishing systems is relocated so that it is located with the other alternative fire-extinguishing systems. Then the requirements for Commercial Cooking Systems are moved to 904.13. This provides for proper formatting and sequencing of code requirements.

The references to Sections 901 and 904.4 are deleted. This reference is redundant since all fire-extinguishing systems must already comply with both Section 901 and Section 904.4.

Section 904.12.1 is revised to specify that inspection and testing records must be maintained. This correlates with the global revisions for record maintenance that occurred in code change ADM43-13.

Cost Impact

The code change proposal will not increase or decrease the cost of construction .

This is an editorial change with no impact on enforcement or application.

Internal ID: 2025

F125-18

IFC: 905.11 (IBC: [F]905.11)

Proponent: David Kerr, Knox Corporation, representing Knox Corporation

2018 International Fire Code

Revise as follows:

905.11 Locking standpipe outlet caps. The *fire code official* is authorized to require locking caps on the outlets on ~~dry~~ standpipes where the responding fire department carries key wrenches for the removal that are compatible with locking FDC connection caps.

Reason:

Wet pipe standpipe systems are subject to vandalism. It has been reported that caps have been removed and valves opened allowing water to flow into stairwells causing flooding to buildings. Removing the word "dry" allows the Fire Department to require or allow the building owner to install locking caps on an as needed bases clarifying the intent of the existing code. If caps are missing, debris can enter the outlet and if not properly cleared, it will clog the fire fighter nozzle.

Cost Impact

The code change proposal will increase the cost of construction .

The cost of the cap is \$250.

Internal ID: 1242

F126-18

IFC: 905.3.1 (IBC: [F] 905.3.1)

Proponent: Robert Davidson, Davidson Code Concepts, LLC, representing Self (rjd@davidsoncodeconcepts.com)

2018 International Fire Code

Revise as follows:

905.3.1 Height. Class III standpipe systems shall be installed throughout buildings where any of the following conditions exist:

1. Four or more stories are above or below grade plane.
2. The floor level of the highest story is located more than 30 feet (9144 mm) above the lowest level of the fire department vehicle access.
3. The floor level of the lowest story is located more than 30 feet (9144 mm) below the highest level of fire department vehicle access.

Exceptions:

1. Class I standpipes are allowed in buildings equipped throughout with an *automatic sprinkler system* in accordance with Section 903.3.1.1 or 903.3.1.2.
2. Class I standpipes are allowed in Group B and E occupancies.
3. Class I ~~manual~~ standpipes are allowed in ~~open parking garages where the highest floor is located not more than 150 feet (45 720 mm) above the lowest level of fire department vehicle access.~~ parking garages.
4. ~~Class I manual~~ Semi-automatic dry standpipes are allowed in open parking garages that are subject to freezing temperatures, ~~provided that the hose connections are located as required for Class II standpipes in accordance with Section 905.5.~~ temperatures.

Reason:

The purpose of this change is to modify the two exceptions addressing standpipe system installed in open parking garages. The exceptions have been in the IFC/IBC unchanged since the 2000 editions of the codes while the materials in vehicles has changed to add more combustible synthetic material, thinner/lighter metals and a growing increase of alternative fueled vehicles, GH2, CNG, LPG and Lithium-Ion batteries. Electric Vehicle charging stations have been installed within parking garages to encourage their use.

Basically, the current requirements for parking garages, open or closed, in the codes are based on old vehicle concepts and studies.

Multi-vehicle large fires can occur and have occurred. As in any multi-story building, effective firefighting actions to protect life and property involved being able to quickly apply water to the fire. The type of fire and danger presented by that fire has increased as the use of alternative fueled vehicles has increased.

This proposal deletes the options for manual standpipes which as a rule require extra effort on the part of the fire service to get water to upper stories and attempt extinguishment of the fire. In place is allowance for Class I standpipes to be installed in any parking garage. The standpipes are there for firefighter use, in the rare occurrence a parking garage opts to have trained personnel they can add the necessary outlet reducer and hose line.

The proposal also calls for semi-automatic dry systems where subject to freezing temperatures. As part of that change the Class II location requirement was eliminated.

NFPA 14 2016 edition

3.3.17.6 Semiautomatic Dry Standpipe System. A standpipe system permanently attached to a water supply that is capable of supplying the system demand at all times arranged through the use of a device such as a deluge valve and that requires activation of a remote control device to provide water at hose connections.

Neither the height of the story the fire is located on or the temperature of the atmosphere impacts the size of the fire and amount of water needed to be rapidly applied. The standpipe systems should meet all the requirements for a semi-automatic dry system which will provide for a more rapid water supply availability.

The fuel loads have changed significantly in parking garages due to modern manufacturing methods and the increased use of alternative fuels. Improvement in the requirements of the codes is necessary to address those changes.

Background material.

<http://www.urbanfiretraining.com/parking-garages.html>

<http://www.firerescuemagazine.com/articles/print/volume-7/issue-2/strategy-and-tactics/fighting-vehicle-fires-in-parking-garages.html>

<http://www.fireengineering.com/ap-news/2018/01/01/parking-garage-fire-destroys-hundreds-of-cars-in-uk.html>

<https://www.youtube.com/watch?v=KVx6avRTNCA>

<https://www.youtube.com/watch?v=HK0U-PKJ1NE>

Cost Impact

The code change proposal will increase the cost of construction .

This proposal will increase costs but is balanced with allowance for Class I standpipes in all parking garages and by eliminating the Class II outlet location requirements. The nature of the fuel load has changed within parking structures and fire protection systems need to be improved to deal with the potential fires.

Internal ID: 2174

F127-18

IFC: 905.4 (IBC: [F]905.4)

Proponent: Kevin Scott, representing KH Scott & Associates LLC (khscottassoc@gmail.com)

2018 International Fire Code

Revise as follows:

905.4 Location of Class I standpipe hose connections. Class I standpipe hose connections shall be provided in all of the following locations:

1. In every required ~~interior~~ exit stairway, a hose connection shall be provided for each story above and below grade plane. Hose connections shall be located at the main floor landing unless otherwise approved by the fire code official.
Exception: A single hose connection shall be permitted to be installed in the open corridor or open breezeway between open stairs that are not greater than 75 feet (22 860 mm) apart.
■
Exception: Where floor areas adjacent to a horizontal exit are reachable from an interior exit stairway hose connection by a 30-foot (9144 mm) hose stream from a nozzle attached to 100 feet (30 480 mm) of hose, a hose connection shall not be required at the horizontal exit.
■
3. In every exit passageway, at the entrance from the exit passageway to other areas of a building.
Exception: Where floor areas adjacent to an exit passageway are reachable from an interior exit stairway hose connection by a 30-foot (9144 mm) hose stream from a nozzle attached to 100 feet (30 480 mm) of hose, a hose connection shall not be required at the entrance from the exit passageway to other areas of the building.
■
4. In covered mall buildings, adjacent to each exterior public entrance to the mall and adjacent to each entrance from an exit passageway or exit corridor to the mall. In open mall buildings, adjacent to each public entrance to the mall at the perimeter line and adjacent to each entrance from an exit passageway or exit corridor to the mall.
5. Where the roof has a slope less than four units vertical in 12 units horizontal (33.3-percent slope), a hose connection shall be located to serve the roof or at the highest landing of an interior exit stairway with access to the roof provided in accordance with Section 1011.12.
6. Where the most remote portion of a nonsprinklered floor or story is more than 150 feet (45 720 mm) from a hose connection or the most remote portion of a sprinklered floor or story is more than 200 feet (60 960 mm) from a hose connection, the fire code official is authorized to require that additional hose connections be provided in approved locations.

Reason:

This proposal is designed to fill a gap in standpipe hose connection requirements. If a standpipe is required, and the required exit stairs are exterior, there is no criteria on location of standpipe hose connections.

For example, IBC Section 406.5.8 requires open parking garages to be provided with a standpipe system when required by Section 905.3. Section 905.3 requires a Class III standpipe system in buildings where the floor level is 30 feet or more above or below the level of fire department vehicle access. So, when a parking garage is required to be provided with a standpipe, the user then refers to Section 905.4 which specifies where the hose connections are to be located. Section 905.4 requires a Class I hose connections at:

1. On each landing of an interior exit stairway – while stairways are provided, they most likely are not interior exit stairways.
2. On each side of horizontal exit – most likely not provided in an open parking garage.
3. In each exit passageway – most likely not provided in an open parking garage.
4. This item is specific to covered malls.
5. On the roof – possibly could be interpreted that the top tier is a roof...
6. This item requires additional connections, beyond the connections listed in Items 1 through 5

The question then arises, where are Class I hose connections required? Therefore, Item 1 is revised to include ALL required stairways.

Section 1027 allows exterior exit stairways in buildings up to six stories in height. A standpipe is required at 4 stories in height, so this building must have a standpipe, but Section 905.4 does not specify anything for exterior exit stairways.

The revision to Item 1 would now include both interior and exterior exit stairways. The exception to Item 3 is revised to correlate with the revision in Item 1.

Cost Impact

The code change proposal will not increase or decrease the cost of construction .

Clarifies application of section.

Internal ID: 2321

F128-18

IFC: 905.9 (IBC: [F] 905.9)

Proponent: Michael O'Brian, Chair, representing FCAC (fcac@iccsafe.org)

2018 International Fire Code

Revise as follows:

905.9 Valve supervision. Valves controlling water supplies shall be supervised in the open position so that a change in the normal position of the valve will generate a supervisory signal at the supervising station required by Section 903.4. Where a fire alarm system is provided, a signal shall be transmitted to the control unit.

Exceptions:

1. Valves to underground key or hub valves in roadway boxes ~~provided by the municipality or public utility~~ do not require supervision.
2. Valves locked in the normal position and inspected as provided in this code in buildings not equipped with a fire alarm system.
3. Control valves and isolation valves for dry manual standpipes are permitted to be locked in the open position.

Reason:

In Exception 1, the removal of the supervision requirement for municipal or public utility roadboxes correlates to a similar proposal made to IFC/IBC 903.4. NFPA 24, referenced by the IFC does not require supervision of private main roadboxes. By removing this text, it would apply to be public and private mains.

In Exception 3, the fire department is the water supply for dry manual standpipe systems. Section 5.6.1 of NFPA 14 specifically states electrical supervision for the control valve in a dry manual standpipe system is not required. This may seem to contradict Section 6.3.7.1 of NFPA 14, but a dry manual standpipe system is not connected to an automatic system water supply. Dry manual standpipes are supplied by the fire department and the valve position is controlled by the fire department. Locking the control valve (if provided) for the dry manual system in the open position insures uninterrupted operation when the system is pressurized.

This proposal is submitted by the ICC Fire Code Action Committee (FCAC). The FCAC was established by the ICC Board of Directors to pursue opportunities to improve and enhance assigned International Codes with regard to fire safety and hazardous materials in new and existing buildings and facilities and the protection of life and property in wildland urban interface areas. In 2017 the Fire-CAC has held 3 open meetings. In addition, there were numerous conference calls, Regional Work Group and Task Group meetings for the current code development cycle, which included members of the committees as well as any interested parties, to discuss and debate the proposed changes. Related documentation and reports are posted on the FCAC website at: <https://www.iccsafe.org/codes-tech-support/cs/fire-code-action-committee-fcac/>

Cost Impact

The code change proposal will decrease the cost of construction .

This proposal clarifies which valves are required to be electrically supervised and which valves are permitted to be locked. This will provide consistency in the market and eliminate alternate interpretations of the code.

Internal ID: 189

F129-18

IFC: 906.1 (IBC: [F] 906.1)

Proponent: Daniel E Nichols, MTA Metro-North Railroad- New York, NY, representing MTA Metro-North Railroad (dnichols@mnr.org)

2018 International Fire Code

Revise as follows:

906.1 Where required. Portable fire extinguishers shall be installed in all of the following locations:

1. In new and existing buildings containing Group A, B, E, F, H, I, M, R-1, R-2, R-4 ~~and or~~ S occupancies.

Exceptions:

1. In Group R-2 occupancies, portable fire extinguishers shall be required only in locations specified in Items 2 through 6 where each dwelling unit is provided with a portable fire extinguisher having a minimum rating of 1-A:10-B:C.
2. In Group E occupancies, portable fire extinguishers shall be required only in locations specified in Items 2 through 6 where each classroom is provided with a portable fire extinguisher having a minimum rating of 2-A:20-B:C.
2. Within 30 feet (9144 mm) distance of travel from commercial cooking equipment and from domestic cooking equipment in Group I-1; I-2, Condition 1; and R-2 college dormitory occupancies.
3. In areas where flammable or combustible liquids are stored, used or dispensed.
4. On each floor of structures under construction, except Group R-3 occupancies, in accordance with Section 3315.1.
5. Where required by the sections indicated in Table 906.1.
6. Special-hazard areas, including but not limited to laboratories, computer rooms and generator rooms, where required by the *fire code official*.

Reason:

The term "occupancy" is not a defined term to cover the actual area when fire extinguisher coverage is required. It is assumed that it is within a building, but could be confused as an outdoor space where the occupant load is calculated for appropriate exiting features or to provide accessible accommodations. Examples would be outdoor patio spaces, passenger train platforms, and outdoor storage areas with weather coverings. This change clarifies the intent of the use of the word "occupancy" as it applies to spaces within buildings.

Cost Impact

The code change proposal will not increase or decrease the cost of construction .

This is a clarification to ensure the application of fire extinguisher installation meets the intent of the existing language. No change in application is intended by this change.

Internal ID: 938

F130-18

IFC: 906.1 (IBC:[F] 906.1)

Proponent: Dave Frable, U.S. General Services Administration, representing U.S. General Services Administration

2018 International Fire Code

Revise as follows:

906.1 Where required. Portable fire extinguishers shall be installed in all of the following locations:

1. In new and existing Group A, B, E, F, H, I, M, R-1, R-2, R-4 and S occupancies.

Exceptions:

1. In Group R-2 occupancies, portable fire extinguishers shall be required only in locations specified in Items 2 through 6 where each dwelling unit is provided with a portable fire extinguisher having a minimum rating of 1-A:10-B:C.
2. In Group E occupancies, portable fire extinguishers shall be required only in locations specified in Items 2 through 6 where each classroom is provided with a portable fire extinguisher having a minimum rating of 2-A:20-B:C.
3. In Group B occupancies protected throughout by an automatic sprinkler system designed and installed in accordance Section 903.3.1.1 utilizing quick-response sprinklers, portable fire extinguishers shall be required only in locations specified in Items 2 through 6.
2. Within 30 feet (9144 mm) distance of travel from commercial cooking equipment and from domestic cooking equipment in Group I-1; I-2, Condition 1; and R-2 college dormitory occupancies.
3. In areas where flammable or combustible liquids are stored, used or dispensed.
4. On each floor of structures under construction, except Group R-3 occupancies, in accordance with Section 3315.1.
5. Where required by the sections indicated in Table 906.1.
6. Special-hazard areas, including but not limited to laboratories, computer rooms and generator rooms, where required by the *fire code official*.

Reason:

The intent of this code change is to permit a building owner to be exempt from installing portable fire extinguishers in common areas as well as tenant spaces in new and existing Group B occupancies if the Group B occupancy is protected throughout with an automatic sprinkler system designed and installed in accordance with NFPA 13 that utilizes quick response sprinklers. The faster acting sprinklers and the lower fuel load associated with Group B occupancies alleviate the need for portable fire extinguishers to be installed throughout non-hazardous areas within this occupancy.

Please note that the typical evacuation strategy for Group B occupancies is for building occupants to evacuate the building or relocate to a safe area within the building in lieu of delaying evacuation/relocation and having occupants attempt to utilize a portable fire extinguisher to try to extinguish a fire.

It should be noted that the requirements in the IFC do not require building occupants to be assigned firefighting duties and be trained to know the locations and proper use of portable fire extinguishers. The IFC (Section 406.3.3) only requires the building owner's employees assigned firefighting responsibilities to be trained to know the locations and proper use of portable fire extinguishers and does not apply to the occupants of the building.

In addition, fire department personnel typically will not use the portable fire extinguishers which have been installed within a building due to the uncertainty they have regarding the subject extinguisher operating when needed. Therefore, the installation of this type of manual extinguishing equipment throughout a Group B occupancy protected by an operational sprinkler system utilizing quick-response sprinklers is questionable and not justifiable.

It should also be noted that the Occupational Safety and Health Administration (OSHA), 29 CFR 1910.157(g)(1), also addresses portable fire extinguishers by specifically stating: "Where the employer has provided portable fire extinguishers **for employee use** in the workplace, the employer shall also provide an educational program to familiarize employees with the general principles of fire extinguisher use and the hazards involved with incipient stage firefighting." Therefore, if portable fire extinguishers have been installed in a building and have been designated for occupant use and incorporated into the building's fire safety plan, training would be required. However, if this protocol

for occupants using portable fire extinguishers is not incorporated in the building's fire safety plan, no training would be required. Hence, the occupants will not be properly trained to use the subject portable fire.

Fire is a rare event; however, should a fire occur in this occupancy, the probability that occupants are knowledgeable and have been trained proficiently in the use of portable fire extinguishers to effectively extinguish a fire is low. We also believe the cost associated with the installation of portable fire extinguishers in these occupancies is unjustified, taking into consideration maintaining the subject fire extinguishers for the life of the building. We also believe these costs savings would be better expended active fire detection and suppression systems.

Some opponents of this code change may argue that fire extinguishers are still the first line of defense in many situations and therefore should not be removed in Group B occupancies since occupants should be able to use them if they choose to do so. However, if this is the case, the installation of portable fire extinguishers in Group B occupancies should be a choice and not a requirement. We believe that when a fire does occur in an office building, evacuation of the building should be the first action of the occupants; in lieu of delaying evacuation/relocation and having untrained occupants attempt to utilize a portable fire extinguisher to try to extinguish a fire.

Lastly, it should be noted that this exception was deleted from the Code in 2012 based on the concerns from fire code officials that it was inappropriate to place complete reliance on automatic fire sprinkler systems for the protection of Group A (Assembly) occupancies (not Group B occupancies) and a National Institute of Standards and Technology (NIST) investigation report of the Station Nightclub fire. In addition, the proposed exception for Group B occupancies does not eliminate portable fire extinguishers where the fire risk is a concern (e.g., special hazard areas, areas where flammable and combustible liquids are stored, used, dispensed, etc.). Therefore, we do not believe that the proposed exception for Group B occupancies will present an increased hazard to the safety of the occupants - evacuation of the building should be the first action of the occupants, not fighting the fire.

Therefore, we believe the installation of this type of manual extinguishing equipment throughout a Group B occupancy equipped with an operational sprinkler system utilizing quick-response sprinklers is questionable and not warranted or cost effective (e.g., installation costs, maintenance costs, etc.) over the life of a building.

Cost Impact

The code change proposal will decrease the cost of construction .

This exception will decrease the initial costs of construction (installation of portable fire extinguisher cabinets and portable fire extinguishers) as well as decreasing the maintenance costs over the life of the building.

Internal ID: 1508

F131-18

IFC: 906.1 (IBC: [F]906.1)

Proponent: Jeffrey Shapiro, representing International Institute of Ammonia Refrigeration
(jeff.shapiro@intlcodeconsultants.com)

2018 International Fire Code

Revise as follows:

906.1 Where required. Portable fire extinguishers shall be installed in all of the following locations:

1. In new and existing Group A, B, E, F, H, I, M, R-1, R-2, R-4 and S occupancies.

Exceptions:

1. In Group R-2 occupancies, portable fire extinguishers shall be required only in locations specified in Items 2 through 6 where each dwelling unit is provided with a portable fire extinguisher having a minimum rating of 1-A:10-B:C.
2. In Group E occupancies, portable fire extinguishers shall be required only in locations specified in Items 2 through 6 where each classroom is provided with a portable fire extinguisher having a minimum rating of 2-A:20-B:C.
3. In storage areas of Group S Occupancies where forklift, powered industrial truck or cart operators are the primary occupants, fixed extinguishers, as specified in NFPA 10, shall not be required where in accordance with all of the following:
 - 3.1. Use of vehicle mounted extinguishers shall be approved by the fire code official.
 - 3.2. Each vehicle shall be equipped with a 10-pound, 40A:80B:C extinguisher affixed to the vehicle using a mounting bracket approved by the extinguisher manufacturer or the fire code official for vehicular use.
 - 3.3. Not less than two spare extinguishers of equal or greater rating shall be available onsite to replace a discharged extinguisher.
 - 3.4. Vehicle operators shall be trained in the proper operation, use and inspection of extinguishers.
 - 3.5. Inspections of vehicle mounted extinguishers shall be performed daily.
2. Within 30 feet (9144 mm) distance of travel from commercial cooking equipment and from domestic cooking equipment in Group I-1; I-2, Condition 1; and R-2 college dormitory occupancies.
3. In areas where flammable or combustible liquids are stored, used or dispensed.
4. On each floor of structures under construction, except Group R-3 occupancies, in accordance with Section 3315.1.
5. Where required by the sections indicated in Table 906.1.
6. Special-hazard areas, including but not limited to laboratories, computer rooms and generator rooms, where required by the *fire code official*.

Reason:

A similar allowance to what is proposed for Exception 3 has been permitted by NFPA 1 since 2006 and was the result of a collaborative effort between the me and the Fire Equipment Manufacturers Association representative at the time. In large storage warehouses where the occupants are primarily riding on powered industrial trucks, it makes more sense to provide the operator with a suitable extinguisher on the truck, with the operator, vs. distributing them around the facility. They are more readily accessible to the operator, improving the speed of deployment, and this proposal requires daily inspections, operator training and the availability of spare extinguishers to improve reliability of fire extinguisher use.

Cost Impact

The code change proposal will decrease the cost of construction .

This proposal may reduce the number of fire extinguishers required in storage areas of Group S occupancies, where permitted by the fire code official.

F132-18

IFC: 906.1 (IBC: [F] 906.1)

Proponent: Richard Kluge, Ericsson Inc., representing Alliance for Telecommunications Industry Solutions (richard.kluge@ericsson.com)

2018 International Fire Code

Revise as follows:

906.1 Where required. Portable fire extinguishers shall be installed in all of the following locations:

1. In new and existing Group A, B, E, F, H, I, M, R-1, R-2, R-4 and S occupancies.

Exceptions:

1. In Group R-2 occupancies, portable fire extinguishers shall be required only in locations specified in Items 2 through 6 where each dwelling unit is provided with a portable fire extinguisher having a minimum rating of 1-A:10-B:C.
2. In Group E occupancies, portable fire extinguishers shall be required only in locations specified in Items 2 through 6 where each classroom is provided with a portable fire extinguisher having a minimum rating of 2-A:20-B:C.
2. Within 30 feet (9144 mm) distance of travel from commercial cooking equipment and from domestic cooking equipment in Group I-1; I-2, Condition 1; and R-2 college dormitory occupancies.
3. In areas where flammable or combustible liquids are stored, used or dispensed.
4. On each floor of structures under construction, except Group R-3 occupancies, in accordance with Section 3315.1.
5. Where required by the sections indicated in Table 906.1.
6. Special-hazard areas, including but not limited to laboratories, computer rooms and generator rooms, where required by the *fire code official*.

Exception: Portable fire extinguishers are not required at normally unmanned buildings or structures where a portable fire extinguisher suitable to the hazard of the location is provided on the vehicle of visiting personnel.

Reason:

The IFC section 906 Commentary repeatedly discusses the use of Portable Fire Extinguishers for incipient fire control to allow for increased time for evacuation, but these benefits are not applicable to unmanned locations.

US telecommunication carriers operate a large number of small unmanned equipment facilities. It is not practical to install and maintain Portable Fire Extinguishers in accordance with NFPA 10 at normally unmanned locations as explained below.

Backup generators at remote telecommunications locations provide telecommunications services when commercial ac power fails. These sites may have diesel fuel or liquified propane gas (LPG) stored either indoors or outdoors. Fuel oil, when used, is typically less than 660 gallons in capacity. The sites are normally unmanned. Technicians will travel to the sites only when needed for repairs or maintenance activities. These sites are considered Utility and Miscellaneous Group U occupancies under the IBC. Adherence to the current Section 906 of the IFC requires keeping an extinguisher at the site in compliance with NFPA 10. This requires monthly inspections. For rarely visited remote locations, compliance to NFPA 10 entails a monthly visit for the sole purpose of inspecting the extinguisher, which while possible, is not reasonable. Certain remote and isolated locations are not accessible or impractical to visit during winter months as access is blocked by snow. Furthermore, if there were a fire, the vast majority of the time, there is no one on site to use the extinguisher as the site is not manned. Having a Portable Fire Extinguisher on the technician's vehicle when servicing the site is a more effective alternative to a fixed site-mounted extinguisher. The Portable Fire Extinguisher carried on the vehicle can be inspected and maintained per NFPA 10 and ready for use if necessary.

From the International Building Code Commentary

Per IBC Section 312, Utility and Miscellaneous Group U Commentary: "Structures housing accessory equipment that is part of a utility or communications system are often classified as Group U occupancies when there is no intent that these structures be occupied except for serving and maintaining the equipment within the structure." This language supports an exemption to clearly state the Portable Fire Extinguishers are not required in unmanned or unoccupied

Group U structures when visiting personnel have extinguishers available.

Related content from NFPA 76, Standard for Fire Protection of Telecommunications Facilities

NFPA 76, Chapter 11, “Small Unoccupied Structures” applies to small normally unoccupied telecommunications sites including on-grade walk-in cabinets, on-grade huts, cell huts, and controlled environmental vaults. Section 11.2.3 clearly states that portable fire extinguishers shall not be required in these facilities.

Related content from CFR, Subchapter N, Artificial Islands and Fixed Structures on the Outer Continental Shelf

Code of Federal Regulations of the United States of America, Subchapter N, Artificial Islands and Fixed Structures on the Outer Continental Shelf, Part 145 Fire-Fighting Equipment also supports the position that fire extinguishers in unmanned locations are not required. Per the CFR, Subchapter N, Artificial Islands and Fixed Structures on the Outer Continental Shelf, Part 14, fire extinguishers are only required when crews will be working at the site on a 24-hour basis. Continual deployment of Portable Fire Extinguishers at unmanned locations provides no value and is not practical.

Cost Impact

The code change proposal will decrease the cost of construction .

The cost of code compliance will decrease if portable fire extinguishers will not be required to be installed and maintained at unmanned locations.

Internal ID: 1614

F133-18

IFC 906.2; IBC: [F] 906.2

Proponent: Daniel E Nichols, MTA Metro-North Railroad- New York, NY, representing MTA Metro-North Railroad (dnichols@mnr.org)

2018 International Fire Code

Revise as follows:

906.2 General requirements. Portable fire extinguishers shall be selected, installed and maintained in accordance with this section and NFPA 10.

Exceptions:

1. The distance of travel to reach an extinguisher shall not apply to the spectator seating portions of Group A-5 occupancies.
2. The distance of travel to reach an extinguisher shall not apply to portions of buildings where a fire safety plan, developed in accordance with Chapter 4, states that only trained employees shall utilize portable fire extinguishers and all others immediately evacuate.
3. Thirty-day inspections shall not be required and maintenance shall be allowed to be once every 3 years for dry-chemical or halogenated agent portable fire extinguishers that are supervised by a *listed* and *approved* electronic monitoring device, provided that all of the following conditions are met:
 - ~~2.1.3.1.~~ Electronic monitoring shall confirm that extinguishers are properly positioned, properly charged and unobstructed.
 - ~~2.2.3.2.~~ Loss of power or circuit continuity to the electronic monitoring device shall initiate a trouble signal.
 - ~~2.3.3.3.~~ The extinguishers shall be installed inside of a building or cabinet in a noncorrosive environment.
 - ~~2.4.3.4.~~ Electronic monitoring devices and supervisory circuits shall be tested every 3 years when extinguisher maintenance is performed.
 - ~~2.5.3.5.~~ A written log of required hydrostatic test dates for extinguishers shall be maintained by the *owner* to verify that hydrostatic tests are conducted at the frequency required by NFPA 10.
- ~~3.4.~~ In Group I-3, portable fire extinguishers shall be permitted to be located at staff locations.

2018 International Building Code

Revise as follows:

[F] 906.2 General requirements. Portable fire extinguishers shall be selected and installed in accordance with this section and NFPA 10.

Exceptions:

1. The distance of travel to reach an extinguisher shall not apply to the spectator seating portions of Group A-5 occupancies.
2. The distance of travel to reach an extinguisher shall not apply to portions of buildings where a fire safety plan, developed in accordance with Chapter 4, states that only trained employees shall utilize portable fire extinguishers and all others immediately evacuate.
3. In Group I-3, portable fire extinguishers shall be permitted to be located at staff locations.

Reason:

The purpose of this proposal is to permit latitude in the locations of portable fire extinguishers within buildings that have a fire safety plan which focuses on prompt evacuation rather than fire extinguisher use.

For those areas covered by the worker protection requirements of OSHA, the removal of the distribution requirements of portable fire extinguishers is addressed in 49 CFR 1910.157(b)(2), which states:

"Where the employer has an emergency action plan meeting the requirements of 1910.38 which designates certain employees to be the only employees authorized to use the available portable fire extinguishers, and which requires all other employees in the fire area to immediately evacuate the affected work area upon the sounding of the fire alarm, the employer is exempt from the distribution requirements in paragraph (d) of this section"

For areas that aren't regulated by OSHA like public access assembly spaces and residential units, training on the use of fire extinguishers is minimal at best. All instructions that are given in public areas and provided on manufacturer's installation instructions for residential smoke alarms is to immediately evacuate when an alarm sounds.

To utilize this exception, one of two processes would need to occur. For most buildings, a fire safety plan required by Section 403 would need to be submitted to the Fire Code Official for approval. Since portable fire extinguishers are a required item of the plan, the layout and specific location of extinguishers would need to be approved. For all other buildings, a fire safety plan would need to be created and be approved by the Fire Code Official even though it isn't required by Chapter 403 (mainly for smaller buildings). Either way, the fire code official approves the modified distribution plan.

In locations where fire extinguishers could be sourced as a potential security issue, the coordination of the fire safety plan and the security priorities of the building ensure both fire protection and security are maintained. By having the ability to move fire extinguishers to areas that are still accessible by trained personnel while lessening a security threat, this promotes maintaining good fire protection while having the fire code official as an integral part of the all-hazards emergency action plan for the building.

As a final note, the intent of this proposal is to maintain the requirement for fire extinguishers in buildings and is not to be construed as a method to remove fire extinguishers completely from buildings. As a point of information, the complete removal is permitted by 1910.157 (b)(1) for workplaces regulated by OSHA; but this proposal is based on the requirements of 1910.157 (b)(2) only.

Cost Impact

The code change proposal will not increase or decrease the cost of construction .

There is no cost impact to construction as this is to provide latitude in the distribution of the portable fire extinguishers.

Internal ID: 940

F134-18

IBC: 907.2 (IBC: [F] 907.2)

Proponent: Ryan Wyse, Hebron Fire Department, representing Hebron Fire Department (ryan.wyse@hebronfd.org)

2018 International Fire Code

Revise as follows:

907.2 Where required—new buildings and structures. An *approved* fire alarm and detection system installed in accordance with the provisions of this code and NFPA 72 shall be provided in new buildings and structures in accordance with Sections 907.2.1 through 907.2.23 and provide occupant notification in accordance with Section 907.5, unless other requirements are provided by another section of this code.

Not fewer than one manual fire alarm box shall be provided in an *approved* location to initiate a fire alarm signal for fire alarm systems employing automatic fire detectors or waterflow detection devices. Where other sections of this code allow elimination of fire alarm boxes due to sprinklers, a single fire alarm box shall be installed.

Exceptions:

1. The manual fire alarm box is not required for fire alarm systems dedicated to elevator recall control and supervisory service.
2. The manual fire alarm box is not required for Group R-2 occupancies unless required by the *fire code official* to provide a means for fire watch personnel to initiate an alarm during a sprinkler system impairment event. Where provided, the manual fire alarm box shall not be located in an area that is open to the public.

Reason:

It is my belief that the intent of the code was to require a fire alarm system capable of: receiving notification of a fire, whether automatically or manually; notify the occupants; and notify the fire department within every building applicable to this code for the following reasons:

- All of the group exceptions use the term "manual fire alarm system" or "manual fire alarm box". If the intent of an exception was to eliminate the requirement of the fire alarm system completely, there would be no reason to specifically say "manual". Using the term manual implies that there must also be an automatic available.

- The definition of "fire alarm system" in 902.1 defines it as a system that monitors and annunciates the status of a fire alarm and initiates the appropriate response. Well, if my building is unsprinklered and an exception to requiring the manual pull station applies to me, what else would my approved fire alarm system that "shall be provided" monitor other than detectors?

The specific occupancy classifications and their exceptions listed in 2.1 through 2.23 only provide permission to omit the required manual pull stations and do not imply the permission to omit the fire alarm system completely. Unfortunately, this is how every fire & building code official I have met has interpreted this. My building code official right now is not requiring a fire alarm system in a tire & repair shop, because they don't have an occupancy load of 500 or more, and so on, per Section 907.2.2. There is a significantly large portion of the code enforcement community that believe that a fire alarm system with detectors is not required when they meet an exception for the manual fire alarm box or the building is unsprinklered.

By adding "and detection" to 907.2, it is my hope that others will have an easier time identifying that an alarm system is still required, even though it may not require the manual pull station. My intent of this code change is not to simply change the wording, but correct the problem. So, if you feel that other wording is more appropriate to achieve this goal, please do so.

Cost Impact

The code change proposal will not increase or decrease the cost of construction .

The proposed change will increase the cost of construction, since they will now have to pay for a fire alarm system that the code official mistakenly waved. However, it also will not increase the costs, because the alarm system has always been required. It just hasn't been enforced properly.

There would also be a cost impact to the insurance industry, because the proper enforcement of the code would mean that the fire department will be notified faster than waiting for someone to call it in when flames are through the roof.



F135-18

IFC: 907.2.1, 907.2.1.1, 907.2.1.2, 907.5.2.2, 907.5.2.2.4, 907.5.2.2.5; IBC: [F] 907.2.1.1 , 1108.2.7.3

Proponent: Gene Boecker, representing Code Consultants, Inc. (geneb@codeconsultants.com)

2018 International Fire Code

907.2.1 Group A. A manual fire alarm system that activates the occupant notification system in accordance with Section 907.5 shall be installed in Group A occupancies where the occupant load due to the assembly occupancy is 300 or more, or where the Group A occupant load is more than 100 persons above or below the *lowest level of exit discharge*. Group A occupancies not separated from one another in accordance with Section 707.3.10 of the International Building Code shall be considered as a single occupancy for the purposes of applying this section. Portions of Group E occupancies occupied for assembly purposes shall be provided with a fire alarm system as required for the Group E occupancy.

Exception: Manual fire alarm boxes are not required where the building is equipped throughout with an automatic sprinkler system installed in accordance with Section 903.3.1.1 and the occupant notification appliances will activate throughout the notification zones upon sprinkler water flow.

Revise as follows:

907.2.1.1 System initiation in Group A occupancies with an occupant load of 1,000 or more. Activation of the fire alarm in Group A occupancies with an *occupant load* of 1,000 or more shall initiate a signal using an emergency voice/alarm communications system in accordance with Section 907.5.2.2.

~~Exception-Exceptions:~~

1. Where *approved*, the prerecorded announcement is allowed to be manually deactivated for a period of time, not to exceed 3 minutes, for the sole purpose of allowing a live voice announcement from an *approved*, constantly attended location.
2. An emergency voice/alarm communication system is not required for open air assembly bleacher seating with an occupant load of less than 15,000 in accordance with ICC 300.

907.2.1.2 Emergency voice/alarm communication system captions. Stadiums, arenas and grandstands required to caption audible public announcements shall be in accordance with Section 907.5.2.2.4.

907.5.2.2 Emergency voice/alarm communication systems. Emergency voice/alarm communication systems required by this code shall be designed and installed in accordance with NFPA 72. The operation of any automatic fire detector, sprinkler waterflow device or manual fire alarm box shall automatically sound an alert tone followed by voice instructions giving *approved* information and directions for a general or staged evacuation in accordance with the building's fire safety and evacuation plans required by Section 404. In high-rise buildings, the system shall operate on at least the alarming floor, the floor above and the floor below. Speakers shall be provided throughout the building by paging zones. At a minimum, paging zones shall be provided as follows:

1. Elevator groups.
2. *Interior exit stairways*.
3. Each floor.
4. *Areas of refuge* as defined in Chapter 2.

Exception: In Group I-1 and I-2 occupancies, the alarm shall sound in a constantly attended area and a general occupant notification shall be broadcast over the overhead page.

907.5.2.2.4 Emergency voice/alarm communication captions. Where stadiums, arenas and grandstands have 15,000 fixed seats or more and provide audible public announcements, the emergency/voice alarm communication system shall provide pre-recorded or real-time captions. Prerecorded or live emergency captions shall be from an *approved* location constantly attended by personnel trained to respond to an emergency.

907.5.2.2.5 Emergency power. Emergency voice/ alarm communications systems shall be provided with emergency power in accordance with Section 1203. The system shall be capable of powering the required load for a duration of not less than 24 hours, as required in NFPA 72.

2018 International Building Code

1108.2.7.3 Public address systems. Where stadiums, arenas and *grandstands* have 15,000 fixed seats or more and provide audible public announcements, they shall also provide prerecorded or real-time captions of those audible public announcements.

Reason:

The ICC 300 Section 309 provides for situations where a emergency voice alarm system is not required. The intent of this proposal is for coordination between those allowances. Typically a more restrictive requirement in the code would over ride an allowance in the standard. For outdoor bleacher systems, the ICC 300 has appropriate thresholds that should be allowed.

SECTION 309

FIRE PROTECTION

309.1 Fire protection. Fire protection systems shall be provided where required by the building code.

Exceptions:

1. An emergency voice/alarm system is not required for outdoor bleacher-type seating provided all of the following are met:

1.1. The bleacher-type seating has an occupant load of less than 15,000;

1.2. A public address system with standby power is provided;

1.3. Enclosed spaces attached or immediately adjacent to the bleacher-type seating comprise, in the aggregate, 10% or less of the overall area of the bleacher-type seating or 1,000 square feet (92.9 square meters), whichever is less.

1.4. Spaces under the bleacher-type seating shall be separated from the bleacher-type seating in accordance with Section 1029.1.1.1 of the International Building Code

1.5. All means of egress from the bleacher-type seating are open to the outside.

2. An emergency voice/alarm system is not required for outdoor bleacher-type seating with an occupant load of 300 or less.

3. An emergency voice/alarm system is not required for temporary outdoor bleacher-type seating providing all of the following are met:

3.1. There are no enclosed spaces under or attached to the bleacher-type seating;

3.2. The bleacher-type seating is erected for a period of less than 180 days;

3.3. Evacuation of the bleacher-type seating is included in an approved fire safety plan.

Cost Impact

The code change proposal will decrease the cost of construction .

If this is allowed, this could be a reduction in requirements for alarms for outdoor bleachers.

Internal ID: 738

F136-18

IFC: 907.2.2 (IBC: [F] 907.2.2)

Proponent: Gene Boecker, representing Code Consultants, Inc. (geneb@codeconsultants.com)

2018 International Fire Code

Revise as follows:

907.2.2 Group B. A manual fire alarm system, that activates the occupant notification system in accordance with Section 907.5, shall be installed in Group B occupancies where one of the following conditions exists:

1. The combined Group B *occupant load* of all floors is 500 or more.
2. The Group B *occupant load* is more than 100 persons above or below the lowest *level of exit discharge*.
3. The *fire area* contains an ambulatory care facility.

Exception: Manual fire alarm boxes are not required where the building is equipped throughout with an *automatic sprinkler system* installed in accordance with Section 903.3.1.1 and the occupant notification appliances will activate throughout the notification zones upon sprinkler water flow.

Reason:

All the other sections in 907.2 include similar phrasing that clearly states that an occupant notification system is a part of the design. The language seeks to clarify the intent and provide consistency among the similar code sections.

Cost Impact

The code change proposal will not increase or decrease the cost of construction .

The code change is clarification only.

Internal ID: 1130

F137-18

IFC: 907.2.22 (IBC: [F] 907.2.22)

Proponent: Richard Kluge, representing Alliance for Telecommunications Industry Solutions
(richard.kluge@ericsson.com)

2018 International Fire Code

Revise as follows:

907.2.22 Battery rooms. An automatic smoke detection system shall be installed in areas containing stationary storage battery systems as required in Section 1206.2.

Exception: Normally unoccupied, stand-alone telecommunications structures with a gross floor area of less than 1500 ft² (140 m²) shall not be required to have an automatic smoke detection system.

Reason:

There is little value to installing a fire or smoke detection system in a small normally unoccupied, stand-alone telecommunications structure. These facilities are categorized as USe Group U facilities under the IBC. There is no intent that these structures be occupied except for servicing and maintaining the equipment they house. The recommended text is consistent with NFPA 1 chapter 52 on Energy Storage Systems as well as pending changes to NFPA 76 on Telecommunications facilities.

Cost Impact

The code change proposal will decrease the cost of construction .

Not requiring detection in these sites will decrease the cost of code compliance in initial construction, as well as ongoing operations, testing, maintenance.

Internal ID: 1955

F138-18

IFC: 907.2.3, 907.2.3.1 (New), 907.2.3.2 (New) (IBC: [F] 907.2.3, [F]907.2.3.1 (New), [F]907.2.3.2 (New))

Proponent: Michael O'Brian, Chair, representing FCAC (fcac@iccsafe.org); Michael Pallett, Telecor Inc., representing Telecor Incorporated (mpallett@telecor.com)

2018 International Fire Code

Delete and substitute as follows:

~~**907.2.3 Group E.** A manual fire alarm system that initiates the occupant notification signal utilizing an emergency voice/alarm communication system meeting the requirements of Section 907.5.2.2 and installed in accordance with Section 907.6 shall be installed in Group E occupancies. Where *automatic sprinkler systems* or smoke detectors are installed, such systems or detectors shall be connected to the building fire alarm system.~~

Exceptions:

- ~~1. A manual fire alarm system is not required in Group E occupancies with an *occupant load* of 50 or less.~~
- ~~2. Emergency voice/alarm communication systems meeting the requirements of Section 907.5.2.2 and installed in accordance with Section 907.6 shall not be required in Group E occupancies with occupant loads of 100 or less, provided that activation of the manual fire alarm system initiates an *approved* occupant notification signal in accordance with Section 907.5.~~
- ~~3. Manual fire alarm boxes are not required in Group E occupancies where all of the following apply:
 - ~~3.1. Interior *corridors* are protected by smoke detectors.~~
 - ~~3.2. Auditoriums, cafeterias, gymnasiums and similar areas are protected by *heat detectors* or other *approved* detection devices.~~
 - ~~3.3. Shops and laboratories involving dusts or vapors are protected by *heat detectors* or other *approved* detection devices.~~~~
- ~~4. Manual fire alarm boxes shall not be required in Group E occupancies where all of the following apply:
 - ~~4.1. The building is equipped throughout with an *approved automatic sprinkler system* installed in accordance with Section 903.3.1.1.~~
 - ~~4.2. The emergency voice/alarm communication system will activate on sprinkler water flow.~~
 - ~~4.3. Manual activation is provided from a normally occupied location.~~~~

907.2.3 Group E. A manual fire alarm system shall be installed in Group E occupancies with an occupant load greater than 50. Where an automatic sprinkler system or a smoke detector system is installed, such systems shall be connected to the building fire alarm system.

Add new text as follows:

907.2.3.1 Manual fire alarm boxes. Manual fire alarm boxes shall be provided unless either of the following applies:

1. Interior corridors are protected by smoke detectors; auditoriums, cafeterias, gymnasiums and similar areas are protected by heat detectors or other approved detection devices; and shops and laboratories involving dusts or vapors are protected by heat detectors or other approved detection devices.
2. The building is equipped throughout with an approved automatic sprinkler system installed in accordance with Section 903.3.1.1, and occupant notification will activate upon sprinkler waterflow, with manual activation provided at a normally occupied location.

907.2.3.2 Occupant notification. Where the occupant load of the Group E occupancy is greater than 100, the fire alarm system shall initiate one of the following:

1. An occupant notification signal utilizing an emergency voice/alarm communications system complying with Sections 907.5.2.2 and 907.6.
2. An occupant notification signal complying with Section 907.5 and an interconnected in-building mass

notification system complying with Sections 907.5.2.2 and installed in accordance with Section 907.6, and NFPA 72.

Reason:

Changes proposed for 907.2.3 are intended to:

- a) improve code language clarity by eliminating complex lists of exceptions;
- b) permit listed mass notification systems in conjunction with fire alarm systems as an alternative to EVAC for occupant notification.

In North America, the risk of death and serious injury in schools has shifted from fire incidences towards incidences of violence through a combination of reduction of fire deaths and an increase of violence. NFPA 72 2010 formally introduced listed (UL 2572) mass notification systems as an enforceable class of emergency communication system (ECS). Mass notification often utilizes both voice and textual notification and is intended to communicate information about emergencies including but not limited to: fire, human caused events (accidental and intentional), other dangerous situations, accidents, and natural disasters.

As threats to children in schools evolve, in-building mass notification systems (MNS) have and are being professionally developed specifically for educational occupancies. MNS are designed to support multiple situations including: environmental, active shooter, hostage, and weather. MNS may include automatic responses such as: lockdown, partial lockdown with partial evacuation, lockdown acknowledgment and tracking, lockout, reverse evacuation, covert monitoring, and others. EVAC systems do not require a risk analysis because the risk of fire in schools is generally well understood. But MNS (as per NFPA 72) does require formal consideration of the risks above by requiring a specific risk analysis be developed for each school.

This proposal provides an option for listed mass notification systems in combination with fire alarm systems as an alternative to EVAC systems in schools. The relationship between fire alarm and in-building mass notification is well-developed in NFPA 72. Some schools are budget limited and cannot support the purchase of both EVAC and MNS. This proposal is intended to provide choice for jurisdictions considering MNS as an option.

The proposed code includes safeguards to ensure the level of protection of the school is not reduced as compared with EVAC. References to NFPA 72 ensure that MNS systems are listed to UL 2572 or UL 864. Both NFPA 72 and UL 2572 require that listed MNS systems are manufactured to common core F.A. standards including: secondary power, monitoring for integrity, supervisory, trouble, emergency control functions, notification and control circuits, annunciation and zoning, pathway class designation, monitoring for integrity and circuit performance, audible characteristics, system performance and integrity, performance of initiating device circuits (IDCs), notification appliance circuits (NACs), and signaling line circuits (SLCs).

This proposal is submitted by the ICC Fire Code Action Committee (FCAC). The FCAC was established by the ICC Board of Directors to pursue opportunities to improve and enhance assigned International Codes with regard to fire safety and hazardous materials in new and existing buildings and facilities and the protection of life and property in wildland urban interface areas. In 2017 the Fire-CAC has held 3 open meetings. In addition, there were numerous conference calls, Regional Work Group and Task Group meetings for the current code development cycle, which included members of the committees as well as any interested parties, to discuss and debate the proposed changes. Related documentation and reports are posted on the FCAC website at: <https://www.iccsafe.org/codes-tech-support/cs/fire-code-action-committee-fcac/>

Cost Impact

The code change proposal will not increase or decrease the cost of construction .

There is no cost impact, because the proposal presents MNS/fire alarm as an option, not a requirement. The restructuring of the paragraph maintains the current requirements so there is no additional cost associated with these changes.

When MNS/fire alarm is chosen, there is the additional cost of the MNS system, but also cost reductions from changing EVAC to manual fire alarm and the elimination of P.A. systems that are normally installed in schools.

Internal ID: 481

F139-18

IFC: 907.2.3 (IBC:[F] 907.2.3)

Proponent: Michael O'Brian, Chair, representing FCAC (fcac@iccsafe.org)

2018 International Fire Code

Revise as follows:

907.2.3 Group E. A manual fire alarm system that initiates the occupant notification signal utilizing an emergency voice/alarm communication system meeting the requirements of Section 907.5.2.2 and installed in accordance with Section 907.6 shall be installed in Group E occupancies. Where *automatic sprinkler systems* or smoke detectors are installed, such systems or detectors shall be connected to the building fire alarm system.

Exceptions:

1. A manual fire alarm system is not required in Group E occupancies with an *occupant load* of 50 or less.
2. Emergency voice/alarm communication systems meeting the requirements of Section 907.5.2.2 and installed in accordance with Section 907.6 shall not be required in Group E occupancies with occupant loads of 100 or less, provided that activation of the manual fire alarm system initiates an *approved* occupant notification signal in accordance with Section 907.5.
3. Manual fire alarm boxes ~~are~~ shall not be required in Group E occupancies where all of the following apply:
 - 3.1. Interior *corridors* are protected by smoke detectors.
 - 3.2. Auditoriums, cafeterias, gymnasiums and similar areas are protected by *heat detectors* or other *approved* detection devices.
 - 3.3. Shops and laboratories involving dusts or vapors are protected by *heat detectors* or other *approved* detection devices.
 - 3.4. Manual activation is provided from a normally occupied location.
4. Manual fire alarm boxes shall not be required in Group E occupancies where all of the following apply:
 - 4.1. The building is equipped throughout with an *approved automatic sprinkler system* installed in accordance with Section 903.3.1.1.
 - 4.2. The emergency voice/alarm communication system will activate on sprinkler water flow.
 - 4.3. Manual activation is provided from a normally occupied location.

Reason:

As currently written, exception #3 allows the elimination of all manual notification means if smoke or heat detection is provided in interior corridors, high occupancy areas and hazardous areas within the school. No detection is required in offices, classrooms, storage rooms, or similar areas. Under the existing exception a fire occurring in one of these areas will be allowed to grow significantly before heat or products of combustion will activate an automatic detector. With no means of manual activation, occupant notification and notification of emergency services will be significantly delayed.

3.4 provides a manual means to alert occupants and notify emergency services and in the event that a fire is discovered in an area without required detection. The provision is identical to that in exception 4 (4.3).

See Proposal 481 from FCAC, if successful this change needs to be correlated with that revised language.

Cost Impact

The code change proposal will not increase or decrease the cost of construction .

There should be no increase in construction cost for this provision. School are typically designed with the Fire Alarm Control Panels located in the normally occupied office area. FACPs typically provide a means for manual fire alarm activation.

Internal ID: 1405

F140-18

IFC: 907.2.8.1 (IBC: [F] 907.2.8.1)

Proponent: Michael O'Brian, Chair, representing FCAC (fcac@iccsafe.org); Thomas Daly (Thomas.Daly@myhscg.com); Richard Roberts, representing Honeywell (richard.roberts@systemsensor.com); Jason Webb, representing Automatic Fire Alarm Association Codes & Standards Committee (jwebb608@gmail.com)

2018 International Fire Code

Revise as follows:

907.2.8.1 Manual fire alarm system. A manual fire alarm system that activates the occupant notification system in accordance with Section 907.5 shall be installed in Group R-1 occupancies.

Exceptions:

1. A manual fire alarm system is not required in buildings not more than two stories in height or having 20 units or less where all individual *sleeping units* and contiguous attic and crawl spaces to those units are separated from each other and public or common areas by not less than 1-hour *fire partitions* and each individual *sleeping unit* has an *exit* directly to a *public way, egress court* or yard.
2. Manual fire alarm boxes are not required throughout the building where all of the following conditions are met:
 - 2.1. The building is equipped throughout with an *automatic sprinkler system* installed in accordance with Section 903.3.1.1 or 903.3.1.2.
 - 2.2. The notification appliances will activate upon sprinkler water flow.
 - 2.3. Not fewer than one manual fire alarm box is installed at an *approved* location.

Reason:

For new construction this change would continue the exemption for two-story or less Group R—1 occupancies from having a fire alarm system as such occupancies require sprinkler protection (with quick response sprinklers) but would limit that exception to those having 20 rooms or less. Sprinkler systems employ an alarm notification appliance (typically a water motor gong or electric bell per the IFC Sec. 903.4.2) which will provide an audible alarm in a small (20 rooms or less) occupancy. Beyond 20 rooms the effectiveness of that audible alarm is questionable

Such fires in two-story motels without automatic sprinkler systems occurred on January 4, 2010 in South Birmingham, AL (4 fatalities on the second floor), on December 14, 2013 in Wausau, WI (20 injuries) and in Point Pleasant Beach, NJ on March 21, 2014 (four fatalities on the second floor).

One additional example of a multiple life-loss fire was the Newport, OR City Center Motel on August 5, 2016, 4 civilian fire deaths and 3 civilian fire injuries. Fire deaths occurred on both the ground floor and the 2nd floor. The fire started on the ground floor. No sprinklers and no reports of a fire alarm system sounding.

These fires resulted in fatalities, as second floor occupants could not escape due to the means of egress being blocked by smoke and flames. In fires resulting in fatalities, no fire alarm system was in place to provide early warning to occupants.

This proposal is submitted by the ICC Fire Code Action Committee (FCAC). The FCAC was established by the ICC Board of Directors to pursue opportunities to improve and enhance assigned International Codes with regard to fire safety and hazardous materials in new and existing buildings and facilities and the protection of life and property in wildland urban interface areas. In 2017 the Fire-CAC has held 3 open meetings. In addition, there were numerous conference calls, Regional Work Group and Task Group meetings for the current code development cycle, which included members of the committees as well as any interested parties, to discuss and debate the proposed changes. Related documentation and reports are posted on the FCAC website at: <https://www.iccsafe.org/codes-tech-support/cs/fire-code-action-committee-fcac/>

Cost Impact

The code change proposal will increase the cost of construction .

This change will impact the cost of construction in a limited number of newly constructed hotels. First some hotel chains are doing this on their own. When you need to add notification (horns and strobes) to these buildings, the cost would be about \$350.00 a device installed.

F141-18

IFC: 907.2.10 (New) (IBC: [F] 907.2.10 (New))

Proponent: Bob Morgan, Fort Worth Fire Department, representing Fort Worth Fire Department

2018 International Fire Code

Add new text as follows:

907.2.10 Group S. A manual fire alarm system that activates the occupant notification system in accordance with Section 907.5 shall be

installed in Group S public- and self-storage occupancies for interior corridors and common areas.

Exception: Manual fire alarm boxes are not required where the building is equipped throughout with an automatic sprinkler system installed in accordance with Section 903.3.1.1, and the occupant notification appliances will activate throughout the notification zones upon sprinkler water flow.

Reason:

We have adopted this amendment in the North Texas region for several years, due to the lack of familiarity of the occupants with the subject building, which may be multi-story in many cases where having interior corridors or common areas.

Cost Impact

The code change proposal will increase the cost of construction .

The requirement for a fire alarm system will increase the cost of construction of such facilities.

Internal ID: 1290

F142-18

IFC: 907.2.10.1, 907.2.10.2 (IBC: [F] 907.2.10.1, [F]907.2.10.2)

Proponent: Frances Bengtsson, representing self (flbengtsson@gmail.com)

2018 International Fire Code

907.2.10 Single- and multiple-station smoke alarms. *Listed* single- and multiple-station smoke alarms complying with UL 217 shall be installed in accordance with Sections 907.2.10.1 through 907.2.10.7 and NFPA 72.

Revise as follows:

907.2.10.1 Group R-1. Single- or multiple-station smoke alarms shall be installed in all of the following locations in Group R-1:

1. In sleeping areas.
2. In every room in the path of the *means of egress* from the sleeping area to the door leading from the *sleeping unit*.
3. In each story within the *sleeping unit*, including *basements*. For *sleeping units* with split levels and without an intervening door between the adjacent levels, a smoke alarm installed on the upper level shall suffice for the adjacent lower level provided that the lower level is less than one full story below the upper level.
4. In each combustible attic space located above dwelling units or sleeping units.

Exception: Smoke detectors located in sleeping areas shall be permitted to be interconnected with an approved automatic heat detector or other approved initiating device in the attic areas in accordance with manufacturers instructions. Attic spaces protected throughout by an automatic sprinkler system in accordance with Section 903.3.1.1 are not required to have an initiating device provided sprinkler flow initiates an alarm audible in all sleeping areas.

907.2.10.2 Groups R-2, R-3, R-4 and I-1. Single or multiple-station smoke alarms shall be installed and maintained in Groups R-2, R-3, R-4 and I-1 regardless of *occupant load* at all of the following locations:

1. On the ceiling or wall outside of each separate sleeping area in the immediate vicinity of bedrooms.
2. In each room used for sleeping purposes.
3. In each story within a *dwelling unit*, including *basements* but not including crawl spaces and uninhabitable attics. In *dwelling units* or *dwelling units* with split levels and without an intervening door between the adjacent levels, a smoke alarm installed on the upper level shall suffice for the adjacent lower level provided that the lower level is less than one full story below the upper level.
4. In each combustible attic space located above dwelling units or sleeping units.

Exception: Smoke detectors located in sleeping areas shall be permitted to be interconnected with an approved automatic heat detector or other approved initiating device in the attic areas in accordance with manufacturers instructions. Attic spaces protected throughout by an automatic sprinkler system in accordance with Section 903.3.1.1 are not required to have an initiating device provided sprinkler flow initiates an alarm audible in all sleeping areas.

Reason:

When a fire on the outside of the structure enters the attic space through vents either by blowing embers or direct flames, a family sleeping on the inside of the structure may not be aware of the fire in the attic until it breaks through the ceiling into the unit and activates smoke detectors. By that time it may be too late for escape or escape may be more difficult. Both situations have been the case in recent fires.

Even if the building is equipped with NFPA 13 D or 13 R sprinkler systems, those systems are not required to have sprinkler heads in the attic. A fire growing undetected in the attic will overwhelm such systems and possibly take it out of service as the attic collapses.

Some have suggested this is a Wildland Urban Interface issue only however embers have been documented to travel in wind and ignite buildings several miles away from WUI areas. Buildings in non WUI areas do not have vents designed to prevent embers from getting into the attic thus those structures are more susceptible to this type of event. Even a single residence with a fire started by a cigarette deposited in leaves or from a trash bin can cause this type of tragedy. This code change will also be submitted into the IRC process in Group B.

See links below:

Carmel NY fire:

<https://community.nfpa.org/community/home-fire-sprinkler-initiative/blog/2013/05/01/one-year-after-fatal-carmel-fire-no-change-in-ny-building-codes>

Tubbs fire:

<https://www.nytimes.com/interactive/2017/10/21/us/california-fire-damage-map.html>

Cost Impact

The code change proposal will increase the cost of construction .

The increased cost is minimal compared to the overall cost of construction.

Internal ID: 2301

F143-18

IFC: 907.3.1 (IBC: [F]907.3.1); IMC: [F]606.4.1

Proponent: Ryan Wyse, representing Hebron Fire Department (ryan.wyse@hebronfd.org)

2018 International Fire Code

Revise as follows:

907.3.1 Duct smoke detectors. Smoke detectors installed in ducts shall be *listed* for the air velocity, temperature and humidity present in the duct. Duct smoke detectors shall be connected to the building's fire alarm control unit where a fire alarm system is required by Section 907.2. Activation of a duct smoke detector shall initiate a visible and audible supervisory signal at a *constantly attended location* and shall perform the intended fire safety function in accordance with this code and the International Mechanical Code. In facilities that are required to be monitored by a supervising station, duct smoke detectors shall report only as a supervisory signal and not as a fire alarm. They Duct smoke detectors installed in new construction shall not be used as a substitute for required open area detection.

Exceptions:

1. The supervisory signal at a constantly attended location is not required where duct smoke detectors activate the building's alarm notification appliances.
2. In occupancies not required to be equipped with a fire alarm system, actuation of a smoke detector shall activate a visible and an audible signal in an *approved* location. Smoke detector trouble conditions shall activate a visible or audible signal in an *approved* location and shall be identified as air duct detector trouble.
3. Unless an alternate means of smoke detection is present in the area being served, duct smoke detectors in existing structures, previously approved as a substitute for required open area detection, shall continue to perform the functions as designed.

2018 International Mechanical Code

Revise as follows:

[F] 606.4.1 Supervision. The duct smoke detectors shall be connected to a fire alarm system where a fire alarm system is required by Section 907.2 of the International Fire Code. The actuation of a duct smoke detector shall activate a visible and audible supervisory signal at a constantly attended location. In facilities that are required to be monitored by a supervising station, duct smoke detectors shall report only as a supervisory signal, not as a fire alarm. Duct smoke detectors installed in new construction shall not be used as a substitute for required open area detection.

Exceptions:

1. The supervisory signal at a constantly attended location is not required where the duct smoke detector activates the building's alarm-indicating appliances.
2. In occupancies not required to be equipped with a fire alarm system, actuation of a smoke detector shall activate a visible and audible signal in an *approved* location. Duct smoke detector trouble conditions shall activate a visible or audible signal in an *approved* location and shall be identified as air duct detector trouble.
3. Unless an alternate means of smoke detection is present in the area being served, duct smoke detectors in existing structures, previously approved as a substitute for required open area detection, shall continue to perform the functions as designed.

Reason:

The purpose of this change is to permit the application of this code to new construction only. Many buildings utilize duct smoke detectors as a means of detecting smoke in open areas. If a building owner is required to change the activation transmission from an alarm to a supervisory, what will then take the place of the open area protection that was once provided by the duct smoke detectors.

One could say that they would be required to install other devices (smoke heads, heat detectors, etc.) to replace this function. However, can we require the installation of new detectors in a building that was previously approved? If we are, then a code official should have no trouble being able to require the installation of tamper switches on sprinkler valves that were also previously approved, but we cannot.

If this code is enforced and the building owner is not required to replace the open area smoke detection function with

another means that transmits its activation as an alarm and not as a supervisory signal, then we will be reducing the fire protection of the building. I feel that it is best that this code be applicable to new construction only and not be enforceable in existing structures unless the open area that it is protecting already has other detectors already in place.

Cost Impact

The code change proposal will increase the cost of construction .

Requiring that all duct smoke detectors, which are presently being used as a means of open area smoke detection, only be permitted to transmit activation as a supervisory signal will require the installation of other detectors, such as smoke heads or heat detectors, to take the place of this alarm function. This change will cost the building owner, because they will be required to hire a qualified alarm installer to install these detectors. Furthermore, they will be required to pay for an architect to draw up plans showing this since they are altering the design of the system.

Internal ID: 2135

F144-18

IFC: 907.4, 907.5, 907.5.1 (New), 907.5.1.1, 907.5.2.1.3 (New), 907.5.2.1.3.1 (New), 907.5.2.1.3.2 (New) (IBC: [F] 907.4, [F]907.5, [F]907.5.1 (New), [F]907.5.1.1, [F]907.5.2.1.3 (New), [F]907.5.2.1.3.1 (New), [F]907.5.2.1.3.2 (New))

Proponent: Michael O'Brian, Chair, representing FCAC (fcac@iccsafe.org)

2018 International Fire Code

Revise as follows:

907.4 Initiating devices. ~~Where manual or automatic alarm initiation is required as part of a fire alarm system, the initiating a fire alarm system is required by another section of this code, occupant notification in accordance with Section 907.5 shall be initiated by one or more of the following. Initiating devices shall be installed in accordance with Sections 907.4.1 through 907.4.3.1.~~

1. Manual fire alarm boxes.
2. Automatic fire detectors.
3. Automatic sprinkler system waterflow devices.
4. Automatic fire-extinguishing systems.

907.5 Occupant notification systems, notification. ~~A fire alarm system shall annunciate at the fire alarm control unit and shall initiate occupant notification upon activation. Occupant notification by fire alarms shall be in accordance with Sections 907.5.1 through 907.5.2.3.3. Where a fire alarm system is required by another section of this code, it shall be activated by:~~

1. ~~Automatic fire detectors.~~
2. ~~Automatic sprinkler system waterflow devices.~~
3. ~~Manual fire alarm boxes.~~
4. ~~Automatic fire-extinguishing systems.~~

Exception: ~~Where notification systems are allowed elsewhere in Section 907 to annunciate at a constantly attended location.~~

907.5.2.3.3. Occupant notification by smoke alarms in Groups R-1 and R-2 Occupancies shall comply with Section 907.5.2.1.3.2.

Add new text as follows:

907.5.1 Alarm activation and annunciation. Upon activation, fire alarm systems shall initiate occupant notification and shall annunciate at the fire alarm control unit, or where allowed elsewhere in Section 907, at a constantly attended location.

~~**907.5.1.1 Presignal feature.** A presignal feature shall not only be installed unless provided where approved by the fire code official. Where a presignal feature is provided, a signal approved. The presignal shall be annunciated at an approved at a constantly attended location approved by the fire code official, so that occupant notification can be activated in having the capability to activate the occupant notification system in the event of fire or other emergency.~~

907.5.2.1.3 Audible signal frequency in Groups R-1 and R-2 sleeping rooms. Audible signal frequency in Groups R-1 and R-2 occupancies shall be in accordance with Sections 907.5.2.1.3.1 and 907.2.1.3.2.

907.5.2.1.3.1 Fire alarm system signal. In sleeping rooms of Groups R-1 and R-2 Occupancies, the audible alarm activated by a fire alarm system shall be a 520 Hz low-frequency signal complying NFPA 72.

907.5.2.1.3.2 Smoke alarm signal in sleeping rooms. In sleeping rooms of Groups R-1 and R-2 Occupancies that are required by Sections 907.2.8 or 907.2.9 to have a fire alarm system, the audible alarm signal activated by single- or multiple-station smoke alarms in the dwelling unit or sleeping unit shall be a 520 Hz signal complying NFPA 72.

Where a sleeping room smoke alarm is unable to produce a 520 Hz signal, the 520 Hz alarm signal shall be provided by a listed notification appliance or a smoke detector with an integral 520 Hz sounder.

Reason:

This Proposal seeks to enhance the waking effectiveness of high risk segments of the population in the International Fire Code (IFC) by requiring a consistent use of the 520 Hz low frequency audible fire alarm signal in new Group R-1 and R-2 occupancies that are required to have a fire alarm system.

This approach is an interim option to get the low frequency signal in buildings where the technology is commercially available and avoids requiring the low frequency signal in buildings where the technology is not currently available in the stream of commerce. The proposal has taken careful consideration to not require the low frequency technology in buildings without a fire alarm system because there are no smoke alarms currently available with an integral sounder capable of producing the low frequency signal. However, it does not prohibit their installation if the product becomes available in the future. The reason the proposal does require the low frequency signal in sleeping areas of buildings with a fire alarm system because there are numerous manufacturers of system connected smoke detectors with an integral sounder that produces the 520 Hz low frequency signal.

Peer-reviewed research has concluded the 520 Hz low frequency is six times more effective than the standard 3 KHz signal at waking high risk segments of the population (people over 65, people who are hard of hearing, school age children and people who are alcohol impaired). The standard 3 KHz audible alarm signal has been used in the majority of fire alarm horns and smoke alarms for the past 30 years.

The reason this Proposal is necessary is because NFPA 72 stipulates both the 520 Hz and 3 KHz signal in the sleeping rooms of hotels, dormitories and apartment building bedrooms when smoke alarms are installed in the sleeping room. Specifically, Chapter 18 of NFPA 72 requires audible notification appliances (horns, speakers or smoke detectors with an integral sounder bases) to produce the 520 HZ low frequency signal in all sleeping rooms of buildings with a protected premises fire alarm system. Whereas Chapter 29 of NFPA 72 only requires smoke alarms to produce the 520 Hz low frequency signal for people with hearing loss or provided voluntarily for those with hearing loss.

The different requirements within NFPA 72 present a life safety issue because the waking effectiveness of the 520 Hz low frequency is superior to 3 KHz audible alarm signal awakening high risk segments of the population. The low frequency signal needs to be provided in areas intended for sleeping for people over 65, people who are hard of hearing, school age children and people who are alcohol impaired.

There are several product solutions currently available in the market capable of providing the 520 Hz low frequency signal.

1. Fire alarm system horns and horn/strobes
2. Smoke detectors with integral sounder bases
3. Speakers connected to an Emergency Voice Alarm Communication (EVAC) system

Peer-Reviewed Research:

Ian R. Thomas and Dorothy Bruck, Waking Effectiveness of Alarms for Adults Who Are Hard of Hearing (Melbourne, Australia: Victoria University), National Fire Protection Association, 2007

This proposal is submitted by the ICC Fire Code Action Committee (FCAC). The FCAC was established by the ICC Board of Directors to pursue opportunities to improve and enhance assigned International Codes with regard to fire safety and hazardous materials in new and existing buildings and facilities and the protection of life and property in wildland urban interface areas. In 2017 the Fire-CAC has held 3 open meetings. In addition, there were numerous conference calls, Regional Work Group and Task Group meetings for the current code development cycle, which included members of the committees as well as any interested parties, to discuss and debate the proposed changes. Related documentation and reports are posted on the FCAC website at: <https://www.iccsafe.org/codes-tech-support/cs/fire-code-action-committee-fcac/>

Cost Impact

The code change proposal will increase the cost of construction .

The code change proposal will increase the cost of construction. The total installation cost will only increase in new R-1 and R-2 occupancies where a fire alarm system is required by Section 907 by requiring the use of the 520 Hz low frequency audible fire alarm signal.

In accordance with the included cost analysis the estimated price increase is \$57 per sleeping room for occupancies that are not required to utilize an emergency voice alarm communication (EVAC) system for occupant notification and approximately \$107 per sleeping room for occupancies that are required to utilize an (EVAC) system for occupant notification.

For non-EVAC systems, the solution utilizes a currently available smoke detector with an integral low frequency sounder base instead of installing a smoke alarm and low frequency horn. For EVAC systems, the solution utilizes a currently available fire alarm system speaker and a smoke detector with an integral low frequency sounder base.

R-1 and R-2 Occupancy with a Non-ULC Fire Alarm System

R-1 and R-2 Occupancy with an ULC Fire Alarm

	Option A		Option B
	Smoke Alarm (220VAC/Battery)	Low Frequency Horns and Additional Power Supplies	Smoke Detector with Low Frequency Sounder Base, Additional Power Supplies and Additional Control Unit Programming
Contractor purchase price of fire alarm equipment	25.00	45.00	115.00
Contract, wire, labor and labor (labor at \$75 per hr)	75.00	240.00	225.00
25% Contractor Overhead/Profit	25.00	46.25	45.00
Total installed (complete) Device per Room	125.00	246.25	425.00

	Option A	
	Smoke Alarm (110VAC/Battery)	Additional Power Supplies and Additional Control
Contractor purchase price of fire alarm equipment	25.00	75.00
Contract, wire, labor and labor (labor at \$75 per hr)	75.00	240.00
25% Contractor Overhead/Profit	25.00	46.25
Total installed (complete) Device per Room	125.00	361.25

Notes:
 Option A: Application meets the current NFPA 72 requirements. The total installed cost of a smoke alarm and a low frequency horn is \$125.00.
 Option B: Requires the low frequency where the technology is commercially available. The total installed cost of the smoke detector w/low frequency sounder base is \$425.00.
 Percent Increase per room: 25.2%
 Dollar Increase per room: \$61.25

Notes:
 Option A: Meets the current NFPA 72 requirements. Total installed cost of a smoke alarm and a low frequency horn is \$361.25.
 Option B: Requires the low frequency where the technology is commercially available. Total installed cost of the smoke detector and a speaker is \$361.25.
 Percent Increase per room: 25.2%
 Dollar Increase per room: \$61.25

F145-18

IFC: 907.4, 907.5, 907.5.1, 907.5.2.1.3 (New), 907.5.2.1.4 (New), 907.5.2.1.4.1 (New), 907.5.2.1.4.2 (New), 907.5.2.1.4.3 (New) (IBC: [F]907.4, [F]907.5, [F]907.5.1, [F]907.5.2.1.3 (New), [F]907.5.2.1.4 (New), 9[F]907.5.2.1.4.1 (New), [F]907.5.2.1.4.2 (New), [F]907.5.2.1.4.3 (New))

Proponent: Jason Webb, Automatic Fire Alarm Association, representing Automatic Fire Alarm Association Codes & Standards Committee

2018 International Fire Code

Revise as follows:

907.4 Initiating devices. ~~Where manual or automatic alarm initiation is required as part of a fire alarm system, the initiating a fire alarm system is required by another section of this code, occupant notification in accordance with Section 907.5 shall be initiated by one or more of the following. Initiating devices shall be installed in accordance with Sections 907.4.1 through 907.4.3.1.~~

1. Manual fire alarm boxes.
2. Automatic fire detectors.
3. Automatic sprinkler waterflow devices.
4. Automatic fire-extinguishing systems.

907.5 Occupant notification systems. ~~A fire alarm system shall annunciate at the fire alarm control unit and shall initiate occupant notification upon activation. Occupant notification shall be in accordance with Sections 907.5.1 through 907.5.2.3.3. Where a fire alarm system is required by another section of this code, it shall be activated by:~~

- ~~1. Automatic fire detectors.~~
- ~~2. Automatic sprinkler system waterflow devices.~~
- ~~3. Manual fire alarm boxes.~~
- ~~4. Automatic fire-extinguishing systems.~~

~~**Exception:** Where notification systems are allowed elsewhere in Section 907 to annunciate at a constantly attended location.~~

Add new text as follows:

907.5.1 General. Occupant notification by fire alarms shall comply with 907.5.2 through 907.5.2.3.3. Occupant notification by smoke alarms in Groups R-1 and R-2 Occupancies shall comply with Section 907.5.2.1.4.2. Upon activation, fire alarm systems shall initiate occupant notification and shall annunciate at the fire alarm control unit, or where allowed elsewhere in Section 907, at a constantly attended location.

Revise as follows:

~~**907.5.1 907.5.1.1 Presignal feature.** A presignal feature shall not be installed unless approved by the fire code official. Where a presignal feature is provided, a signal only be provided where approved. The presignal shall be annunciated at a constantly attended location approved by the fire code official, so that occupant notification can be activated having the capability to activate the occupant notification system in the event of fire or other emergency.~~

Add new text as follows:

907.5.2.1.3 Sleeping area requirements. In sleeping areas, the minimum sound level at the pillow shall be 75 dBA, or 15 dB above the average ambient sound level, or 5 dB above the maximum sound level having a duration of at least 60 seconds, whichever is greater.

907.5.2.1.4 Audible signal frequency in Groups R-1 and R-2 sleeping rooms. Audible signal frequency in Groups R-1 and R-2 sleeping rooms shall comply with Sections 907.5.2.1.4.1 through 907.5.2.1.4.3.

907.5.2.1.4.1 Fire alarm system signal. In sleeping rooms of Groups R-1 and R-2 Occupancies, the audible alarm activated by a fire alarm system shall be a 520 Hz low-frequency signal complying NFPA 72.

907.5.2.1.4.2 Smoke alarm signal. In sleeping rooms of Groups R-1 and R-2 Occupancies that are required by Sections 907.2.8 or 907.2.9 to have a fire alarm system, the audible alarm signal shall be a 520 Hz low-frequency signal complying NFPA 72 and shall be provided by one of the following:

1. A single- or multiple-station smoke alarm.
2. A 520 Hz alarm notification appliance activated by a single- or multiple-station smoke alarm.
3. A smoke detector with an integral 520 Hz low frequency sounder.

907.5.2.1.4.3 Sound level. The minimum sound level shall be in accordance with 907.5.2.1.3.

Reason:

This Proposal seeks to enhance the waking effectiveness of high risk segments of the population in the International Fire Code (IFC) by requiring the 520 Hz low frequency audible fire alarm signal in new Group R-1 and R-2 occupancies that are required to have a fire alarm system. The proposal does not require the low frequency technology in buildings without a fire alarm system because there are no smoke alarms currently available with an integral sounder capable of producing the low frequency signal. However, it does not prohibit their installation if the product becomes available in the future. The reason the proposal does require the low frequency signal in sleeping areas of Group R-1 and R-2 buildings with a fire alarm system is because there are numerous manufacturers of system connected smoke detectors with an integral sounder that produces the 520 Hz low frequency signal.

The reason this Proposal is necessary is because NFPA 72 stipulates both the 520 Hz and 3 KHz signal in the sleeping rooms of hotels, dormitories and apartment building bedrooms when smoke alarms are installed in the sleeping room. Specifically, Chapter 18 of NFPA 72 requires audible notification appliances (horns, speakers or smoke detectors with an integral sounder bases) to produce the 520 Hz

low frequency signal in all sleeping rooms of buildings with a protected premises fire alarm system. Whereas Chapter 29 of NFPA 72 only requires smoke alarms to produce the 520 Hz low frequency signal for people with hearing loss or provided voluntarily for those with hearing loss.

The different requirements within NFPA 72 present a life safety issue because peer-reviewed research has concluded the waking effectiveness of the 520 Hz low frequency is superior to 3 KHz audible alarm signal awakening high risk segments of the population. Peer-reviewed research has concluded the 520 Hz low frequency is six times more effective than the standard 3 KHz signal at waking high risk segments of the population (people over 65, people who are hard of hearing, school age children and people who are alcohol impaired). The standard 3 KHz audible alarm signal has been used in most fire alarm horns and smoke alarms for the past 30 years. The low frequency signal needs to be provided in areas intended for sleeping to protect people over 65, people who are hard of hearing, school age children and people who are alcohol impaired.

There are several product solutions currently available in the market capable of providing the 520 Hz low frequency signal.

Fire alarm system horns and horn/strobes

Smoke detectors with integral sounder bases

Speakers connected to an in-building fire alarm Emergency Voice Alarm Communication (EVAC) system

Peer-Reviewed Research:

Ian R. Thomas and Dorothy Bruck, Waking Effectiveness of Alarms for Adults Who Are Hard of Hearing (Melbourne, Australia: Victoria University), National Fire Protection Association, 2007

Cost Impact

The code change proposal will increase the cost of construction .

The code change proposal will increase the cost of construction. The code change proposal will increase the cost of construction. The total installation cost will only increase in new R-1 and R-2 occupancies where a fire alarm system is required by Section 907 by requiring the use of the 520 Hz low frequency audible fire alarm signal.

In accordance with the included cost analysis the estimated price increase is \$57 per sleeping room for occupancies that are not required to utilize an emergency voice alarm communication (EVAC) system for occupant notification and approximately \$107 per sleeping room for occupancies that are required to utilize an (EVAC) system for occupant notification.

For non-EVAC systems, the solution utilizes a currently available smoke detector with an integral low frequency sounder base instead of installing a smoke alarm and low frequency horn. For EVAC systems, the solution utilizes a currently available fire alarm system speaker and a smoke detector with an integral low frequency sounder base.

F146-18

IBC: 907.4.2.4 (IBC:[F] 907.4.2.4)

Proponent: Kevin Duerr-Clark, NYSDOS, representing New York State Department of State (kevin.duerr-clark@dos.ny.gov)

2018 International Fire Code

Revise as follows:

907.4.2.4 Signs. Where fire alarm systems are not required to be monitored by a~~an approved~~ supervising station in accordance with Section 907.6.6, an *approved* permanent sign shall be installed adjacent to each manual fire alarm box that reads: WHEN ALARM SOUNDS – CALL FIRE DEPARTMENT.

Exception: Where the manufacturer has permanently provided this information on the manual fire alarm box.

Reason:

This code change proposal is intended to clarify that one cannot simply install a sign to bypass the monitoring requirements of Section 907.6.6. According to the 2015 IBC Commentary for Section 907.4.2.4: "This section has limited application because, as indicated in Section 907.6.6, fire alarm systems generally must be monitored by an approved supervising station. When a system is not monitored, such as possibly a fire alarm system that is not required by code, adequate signage must be displayed to tell occupants what response actions must be taken."

Because Chapter 9 of the IBC is coordinated with Chapter 9 of the IFC, the corresponding change must be made in the IFC.

Cost Impact

The code change proposal will not increase or decrease the cost of construction .

It is simply a clarification of the code the is already in place.

Internal ID: 1192

F147-18

IFC: 907.5.2.1, 907.5.2.3 (IBC: [F]907.5.2.1, [F]907.5.2.3)

Proponent: John Williams, Chair, representing Healthcare Committee (AHC@iccsafe.org)

2018 International Fire Code

Revise as follows:

907.5.2.1 Audible alarms. Audible alarm notification appliances shall be provided and emit a distinctive sound that is not to be used for any purpose other than that of a fire alarm.

Exceptions:

1. Audible alarm notification appliances are not required in critical care areas of Group I-2, Condition 2 occupancies that are in compliance with Section 907.2.6, Exception 2.
2. A visible alarm notification appliance installed in a nurses' control station or other continuously attended staff location in a Group I-2, Condition 2 suite shall be an acceptable alternative to the installation of audible alarm notification appliances throughout the suite or unit in Group I-2, Condition 2 occupancies that are in compliance with Section 907.2.6, Exception 2.
3. Where provided, audible notification appliances located in each enclosed occupant evacuation elevator lobby in accordance with Section 3008.9.1 of the International Building Code shall be connected to a separate notification zone for manual paging only.

907.5.2.3 Visible alarms. Visible alarm notification appliances shall be provided in accordance with Sections 907.5.2.3.1 through 907.5.2.3.3.

Exceptions:

1. Visible alarm notification appliances are not required in *alterations*, except where an existing fire alarm system is upgraded or replaced, or a new fire alarm system is installed.
2. Visible alarm notification appliances shall not be required in *exits* as defined in Chapter 2.
3. Visible alarm notification appliances shall not be required in elevator cars.
4. Visual alarm notification appliances are not required in critical care areas of Group I-2, Condition 2 occupancies that are in compliance with Section 907.2.6, Exception 2.
5. A visible alarm notification appliance installed in a nurses' control station or other continuously attended staff location in a Group I-2, Condition 2 suite shall be an acceptable alternative to the installation of visible alarm notification appliances throughout the suite or unit in Group I-2, Condition 2 occupancies that are in compliance with Section 907.2.6, Exception 2.

Reason:

There should be an exception for both visible and audible alarms in hospitals. Current text is only audibles. Visible alarms can cause harmful distractions similar to audible distractions when delivering care. For example, delicate surgery such as neurological (brain / spine) surgery, cardiac surgery or any invasive procedure which is adjacent to arteries or veins requires precision. A visual flash or sudden alarm can cause a surgeon to startle, which could have devastating consequences to the patient. To mitigate this situation in the surgery environment, the Circulating or Charge Nurse in the surgical area is responsible for being aware of the alarms of the surgical suite, and is at a continuously monitored control station that serves the unit or suite. This staff is directly involved in the emergency response. The staff then informs the surgical team of the situation in a manner appropriate for the level of care. This eliminates the need for the startling alarms in the operation room, and the team can react to the situation by safely closing the patient.

This proposal is submitted by the ICC Committee on Healthcare (CHC). The CHC was established by the ICC Board to evaluate and assess contemporary code issues relating to healthcare facilities. This is a joint effort between ICC and the American Society for Healthcare Engineering (ASHE), a subsidiary of the American Hospital Association, to eliminate duplication and conflicts in healthcare regulation. In 2017 the CHC held 2 open meetings and numerous conference calls, which included members of the committees as well as any interested parties, to discuss and debate the proposed changes. Information on the CHC, including: meeting agendas; minutes; reports; resource documents; presentations; and all other materials developed in conjunction with the CHC effort can be downloaded from the CHC website at: <https://www.iccsafe.org/codes-tech-support/cs/icc-committee-on-healthcare/>.

Cost Impact

The code change proposal will decrease the cost of construction .

This is a removal of some of the visual alarms in the rooms to ensure patient safety. Staff will notify doctors and address care recipients protection.

Internal ID: 690

F148-18

IFC: 907.5.2.1.2 (IBC: [F] 907.5.2.1.2)

Proponent: Michael O'Brian, Chair, representing FCAC (fcac@iccsafe.org); Richard Roberts, representing Honeywell (richard.roberts@systemsensor.com); Jason Webb, representing Automatic Fire Alarm Association Codes & Standards Committee (jwebb608@gmail.com)

2018 International Fire Code

Revise as follows:

907.5.2.1.2 Maximum sound pressure. ~~The maximum total sound pressure level for audible alarm produced by combining the ambient sound pressure level with all audible notification appliances operating shall be not exceed 110~~ dBA at the minimum hearing distance from the audible appliance. Where the average ambient noise is greater than ~~95~~ 105 dBA, visible alarm notification appliances shall be provided in accordance with NFPA 72 and audible alarm notification appliances shall not be required.

Reason:

This Proposal seeks to align the sound pressure level requirements for audible fire alarm notification appliances in the 2018 edition of the International Fire Code (IFC) with the 2016 edition of the NFPA 72 ®. Section 18.4.1.2 of NFPA 72 stipulates total sound pressure level (produced by combining the ambient sound pressure level with all audible notification appliances operating) shall not exceed 110 dBA. This section includes annex material covering OSHA worker exposure noise levels and an OSHA table for calculating permissible noise exposures.

This proposal is submitted by the ICC Fire Code Action Committee (FCAC). The FCAC was established by the ICC Board of Directors to pursue opportunities to improve and enhance assigned International Codes with regard to fire safety and hazardous materials in new and existing buildings and facilities and the protection of life and property in wildland urban interface areas. In 2017 the Fire-CAC has held 3 open meetings. In addition, there were numerous conference calls, Regional Work Group and Task Group meetings for the current code development cycle, which included members of the committees as well as any interested parties, to discuss and debate the proposed changes. Related documentation and reports are posted on the FCAC website at: <https://www.iccsafe.org/codes-tech-support/cs/fire-code-action-committee-fcac/>

Cost Impact

The code change proposal will not increase or decrease the cost of construction .

This code change proposal provides clarity and alignment with NFPA 72, National Fire Alarm and Signaling Code which is a referenced document.

Internal ID: 268

F149-18

IFC: 907.5.2.2.5 (IBC: [F] 907.5.2.2.5), 1203.2.4; IBC: 2702.2.4

Proponent: Michael O'Brian, Chair, representing FCAC (fcac@iccsafe.org); Jason Webb, representing Automatic Fire Alarm Association Codes & Standards Committee (jwebb608@gmail.com)

2018 International Fire Code

Revise as follows:

907.5.2.2.5 Emergency power. Emergency voice/ alarm communications systems shall be provided with emergency power in accordance with Section 1203. ~~The system shall be capable of powering the required load for a duration of not less than 24 hours, as required in NFPA 72.~~

1203.2.4 Emergency voice/alarm communication systems. Emergency power shall be provided for emergency voice/alarm communication systems as required in Section 907.5.2.2.5. ~~The system shall be capable of powering the required load for a duration of not less than 24 hours, as required in NFPA 72.~~

2018 International Building Code

Revise as follows:

~~**[F] 2702.2.4 Emergency voice/alarm communication systems.**~~ **Voice Alarm Communication Systems.** Emergency power shall be provided for emergency voice/alarm communication systems as required in Section 907.5.2.2.5. ~~The system shall be capable of powering the required load for a duration of not less than 24 hours, as required in NFPA 72.~~

Reason:

This code change is to provide clarification that the standby power for the EVACs system is to be designed to comply with NFPA 72.

We are deleting the reference and code section 1203.2.4. This is causing confusion and the standby power requirements for Fire Alarm systems is clearly outlined in NFPA 72.

This section contradicts itself. NFPA 72 10.6.7.2.1.2 requires secondary power for 24 hours under quiescent load but also requires the secondary power to be capable of operating the system for 15 minutes at maximum load after the 24 hours. Deleting the time and simply referencing the standard insures consistency.

This proposal is submitted by the ICC Fire Code Action Committee (FCAC). The FCAC was established by the ICC Board of Directors to pursue opportunities to improve and enhance assigned International Codes with regard to fire safety and hazardous materials in new and existing buildings and facilities and the protection of life and property in wildland urban interface areas. In 2017 the Fire-CAC has held 3 open meetings. In addition, there were numerous conference calls, Regional Work Group and Task Group meetings for the current code development cycle, which included members of the committees as well as any interested parties, to discuss and debate the proposed changes. Related documentation and reports are posted on the FCAC website at: <https://www.iccsafe.org/codes-tech-support/cs/fire-code-action-committee-fcac/>

Cost Impact

The code change proposal will decrease the cost of construction .

Depending on interpretation this could reduce the cost of construction. Overall this will provide code clarity and alignment with NFPA 72 and within the IBC-IFC

Internal ID: 295

F150-18

IFC: 907.5.2.3.3, 907.5.2.3.4 (New), 907.5.2.3.5 (New), 907.5.2.3.6 (New) (IBC [F] 907.5.2.3.3, [F]907.5.2.3.4 (New), [F]907.5.2.3.5 (New), [F]907.5.2.3.6 (New))

Proponent: Jason Webb, Automatic Fire Alarm Association, representing Automatic Fire Alarm Association Codes & Standards Committee

2018 International Fire Code

Revise as follows:

907.5.2.3.3 Group R-2. In Group R-2 occupancies required by Section 907 to have a fire alarm system, each story that contains dwelling units and sleeping units shall be provided with the future capability to support visible alarm notification appliances in accordance with Chapter 11 of ICC A117.1. Such capability shall accommodate wired or wireless equipment. ~~The future capability shall include one of the following:~~

- ~~• 1.The interconnection of the building fire alarm system with the unit smoke alarms.~~
- ~~• 2.The replacement of audible appliances with combination audible/visible appliances.~~
- ~~3.The future extension of the existing wiring from the unit smoke alarm locations to required locations for visible appliances.~~

Add new text as follows:

907.5.2.3.4 Documentation. Documentation shall be provided within the fire alarm shop drawings to show that the building fire alarm panel has the power supply to handle expansion of visual notification devices in each living unit

907.5.2.3.5 Pathways and Circuits. The power, pathways and circuits shall be vertically extended in the buildings riser. Pathways and circuits are not required to be run into the dwelling units for future use.

907.5.2.3.6 Future capability. The future capability shall include one of the following:

1. Replacement of smoke alarms with smoke alarms with visible alarm notification appliances.
2. The replacement of audible appliances with combination audible/visible appliances or new visible appliances.

Reason:

This code change will clear up confusion that has been in this section of the code. This is an important section of the code. Group R-1 occupancies have a table to refer too to determine how many hotel rooms need to be designed for hearing impaired. In R-2 occupancies we do not have a table or prescriptive direction on how many apartment/condos to have arranged for hearing impaired to comply with A.117.1. So the practice is when someone moves into a dwelling unit or sleeping that does not have the needed safety items, they need to be provided.

The current code attempts to do this by calling for “capacity and be capable of” is vague and unenforceable language. Many code officials and engineers take the worse case position and say that you need to “pre-wire” to every dwelling unit and bedroom for a possible future visual notification device to be connected to the building fire alarm system. That is costing tens of thousands of dollars extra construction costs that only a very small fraction may be used.

First thing to understand, to our understanding is that the key point in A117.1 is to provide visual notification to the occupants in case of fire. That is the mission. The above code change proposal follows this logic and understanding

New Apartment/ Condo R-2

Each dwelling unit gets smoke alarms installed in each sleeping unit and main hall, all interconnected-one goes off, they all go off in that dwelling unit

The building fire alarm system needs to extend audible notification device into each dwelling unit so the occupants are notified when there is a fire in the building.

The smoke alarms will let them know if there is a fire in their dwelling unit, and the building fire alarm system audible notification device (horn/speaker) will let them know there is a fire in the building.

New Apartment/ Condo R-2 with Hearing Impaired occupant

The building owner would just replace the smoke alarms (110 VAC) with smoke alarms with built-in strobes. One goes off; they all go off, giving the dwelling unit occupant visual notification of a problem in “Their” unit.

The building fire alarm system will need to expand into the dwelling unit with visual notification devices in each bedroom and main living area. You start with the existing horn/speaker change it to a horn/strobe or speaker strobe and extend the circuit within the dwelling unit from the existing notification device to power the new visual devices.

The other key to this is the new code language that requires the fire alarm shop drawings to show the system has the necessary power supplies and circuits to accomplish this task, and that this is extended vertically in the building if it is applicable. So the main extra power will always be in the panel and in the riser as needed, and the work within the dwelling unit will be minimal, but you will only be investing in work that needs to be done to provide safety for an occupant that is there.

Cost Impact

The code change proposal will decrease the cost of construction .

This will REDUCE the cost on construction on most installations going forward as it clarifies the intent of the code, and eliminates costly work that was being done that was not required by the Code. The details are explained in the reason statement.

Internal ID: 1807

F151-18

IFC: 907.5.2.3.3 (IBC: [F] 907.2.3.3)

Proponent: Adria Reinertson, Riverside County Fire Department, representing Riverside County Fire Department, California Fire Chiefs Association (adriar@moval.org)

2018 International Fire Code

Revise as follows:

907.5.2.3.3 Group R-2. In Group R-2 occupancies required by Section 907 to have a fire alarm system, each *story* that contains *dwelling units* and *sleeping units* shall be provided with the ~~future~~ capability to support future visible alarm notification appliances in accordance with Chapter 11 of ICC A117.1. Such capability shall accommodate wired or wireless equipment. The future capability shall include one of the following:

1. ~~The~~ A path to allow for future interconnection of the building fire alarm system with the unit smoke alarms in order to activate and power the required visual signals in accordance with NFPA 72 and in accordance with the manufacturer's instructions.
2. The replacement of audible appliances with combination audible/visible appliances or additional visible appliances as required.
3. ~~The future extension of the existing wiring from the unit smoke alarm locations to required locations for visible appliances.~~ Replace unit smoke alarms with system smoke alarms.

Plans for future design capability shall be submitted with the fire alarm system shop drawings to the fire code official.

Reason:

There is much confusion in the fire alarm industry and with fire code officials on how to interpret this section. Currently, fire alarm designers are proposing from just providing additional power supplies for future expansion to installing additional power supplies and extending the notification circuits to every dwelling unit in an R-2 Occupancy. This proposal clarifies how to provide for future expandability with reference to NFPA 72, National Fire Alarm and Signaling Code for the path (rated wiring above the corridor or wiring in conduit), and the fire alarm system manufacturer's requirements.

Option 1 identifies to provide a path in the initial system design to provide for future interconnect the building fire alarm system, which is 24 volt DC system with the unit smoke alarms, which are 110 volt AC devices. To accomplish this, the fire alarm system designer must follow the prescriptive requirements in NFPA 72. The reference is added to identify this design requirement.

Option 2 is modified to include visible notification appliances, allowing where there are locations where only a visible notification appliance is required, due to adequate evacuation sound decibels in the room.

Option 3 language is deleted due to 110 volt AC smoke alarms do not allow for connecting visible notification appliances to the smoke alarms. The smoke alarms are 110 volt AC devices which cannot control a visible appliance. In its place, the option of replacing building smoke alarms with building system smoke detectors is provided. In this scenario, the building's fire alarm system notification appliances would be used to meet the visible requirement on Section 907.5.2.3.3.

The last sentence is added to clarify the method of future design capability will be identified during system design approval by the Fire Code Official.

Cost Impact

The code change proposal will not increase or decrease the cost of construction .

Will not increase the cost of construction. The proposal is clarifying the prescriptive installation requirements. There could be additional cost for those companies/designers who were not installing for future expansion, but the requirement is not changing.

Internal ID: 771

F152-18

IFC: 907.5.2.3.3 (IBC: [F]907.5.2.3.3)

Proponent: Jeffrey Shapiro, representing Self (jeff.shapiro@intlcodeconsultants.com)

2018 International Fire Code

Revise as follows:

907.5.2.3.3 Group R-2. In Group R-2 occupancies required by Section 907 to have a fire alarm system, each *story* that contains *dwelling units* and *sleeping units* shall be provided with the future capability to support visible alarm notification appliances in accordance with Chapter 11 of ICC A117.1. Such capability shall accommodate wired or wireless equipment. The future capability shall include one of the following:

1. The interconnection of the building fire alarm system with the unit smoke alarms.
2. The replacement of audible appliances with combination audible/visible appliances.
3. The future extension of the existing wiring from the unit smoke alarm locations to required locations for visible appliances.

For wired equipment, the fire alarm power supply and circuits shall have not less than 5% excess capacity to accommodate future addition of visible alarm notification appliances, and access to such circuits shall be available on every story. Such circuits shall not be required to be extended beyond a single access point on a story.

Reason:

Last cycle, F213-16 was approved with the intent of clarifying and standardizing the capability for future additions of alarm equipment to accommodate changes for units that may need to be converted to accommodate hearing impaired occupants. The question of a reasonable percentage for excess capacity of wired equipment was left unresolved, and I committed to bringing something back to address this so that the fire alarm industry would have a standardized basis for designing excess capacity into systems. The proposed text has been prepared based on what I learned in a discussion with an individual who has been instrumental in the development of ANSI A117.1 regarding the intent of the standard and his experience as an accessibility expert with respect to the relatively low frequency of units being retrofitted for hearing impaired occupants.

Cost Impact

The code change proposal will not increase or decrease the cost of construction .

The requirement for future expansion capability already exists in this section. I am just trying to quantify the provision, so the cost consequence cannot be accurately assessed, since some installations my previously have provided more expansion capability and others less.

Internal ID: 2018

F153-18

IFC: 907.6.5 (IBC: [F] 907.6.5)

Proponent: Michael O'Brian, Chair, representing FCAC (fcac@iccsafe.org); Richard Roberts, representing Honeywell (richard.roberts@systemsensor.com); Jason Webb, representing Automatic Fire Alarm Association Codes & Standards Committee (jwebb608@gmail.com)

2018 International Fire Code

Revise as follows:

907.6.5 Access-Access and visibility. Access shall be provided to ~~each fire alarm device and notification appliance for devices, notification appliances, and equipment requiring periodic inspection, maintenance and testing.~~ Where devices, notification appliances and equipment are concealed from view, an approved sign or other means to identify their location shall be provided.

Reason:

One of the causes of "unwanted alarms" is identified as fire alarm devices that get installed but are not accessible to perform routine inspection, testing and maintenance. Duct mounted smoke detectors; detection in elevator shafts and atrium detection are some of the key areas of concern. During construction and initial testing special equipment is provided to reach these spaces, but when the building is in normal operation these special lifts and appliances are not available. Leaving smoke devices not tested or maintained.

This proposal is submitted by the ICC Fire Code Action Committee (FCAC). The FCAC was established by the ICC Board of Directors to pursue opportunities to improve and enhance assigned International Codes with regard to fire safety and hazardous materials in new and existing buildings and facilities and the protection of life and property in wildland urban interface areas. In 2017 the Fire-CAC has held 3 open meetings. In addition, there were numerous conference calls, Regional Work Group and Task Group meetings for the current code development cycle, which included members of the committees as well as any interested parties, to discuss and debate the proposed changes. Related documentation and reports are posted on the FCAC website at: <https://www.iccsafe.org/codes-tech-support/cs/fire-code-action-committee-fcac/>

Cost Impact

The code change proposal will not increase or decrease the cost of construction .

In 95% of all cases there will be no additional cost to install the fire alarm system and devices when properly designed. In some specific cases it may be more expensive to install the device "correctly" but that is the right way to do it.

Internal ID: 276

F154-18

IFC: 907.6.6.1 (IBC: [F]907.6.6.1)

Proponent: Michael O'Brian, Chair, representing FCAC (fcac@iccsafe.org); Shane Clary, Bay Alarm Company, representing Automaric Fire Alarm Association, Inc. (smclary@bayalarm.com); Jason Webb, representing Automatic Fire Alarm Association Codes & Standards Committee (jwebb608@gmail.com)

2018 International Fire Code

Revise as follows:

~~**907.6.6.1 Automatic telephone dialing devices.** Automatic telephone dialing devices used to transmit an emergency alarm shall not be connected to any fire department telephone number unless approved by the fire chief.~~**Transmission of alarm signals.** Transmission of alarm signals to a supervising station shall be in accordance with NFPA 72

Reason:

The communications industry has changed more in the last 10 years than the previous one hundred and the rate of technology development is expected to continue escalating over the next 10 years as well. This change has impacted the transmission of alarm, trouble and supervisory signals from the protected premises to the supervising station. The technology used since the late 1980's used private copper telephone lines with power originating at the telephone central office. This technology is becoming a thing of the past because it's unsustainable by the telephone companies. It is estimated that some 70,000 plain old telephone system (POTS) lines are cancelled by consumers every month. Costs of maintaining the copper lines are growing and AT&T recently announced a sunset date of 2018 for POTS.

The automatic dialer devices are not longer used, or approved within NFPA 72. Providing the direct reference to NFPA 72 will cover the advancements in technologies and they move forward.

This proposal is submitted by the ICC Fire Code Action Committee (FCAC). The FCAC was established by the ICC Board of Directors to pursue opportunities to improve and enhance assigned International Codes with regard to fire safety and hazardous materials in new and existing buildings and facilities and the protection of life and property in wildland urban interface areas. In 2017 the Fire-CAC has held 3 open meetings. In addition, there were numerous conference calls, Regional Work Group and Task Group meetings for the current code development cycle, which included members of the committees as well as any interested parties, to discuss and debate the proposed changes. Related documentation and reports are posted on the FCAC website at: <https://www.iccsafe.org/codes-tech-support/cs/fire-code-action-committee-fcac/>

Cost Impact

The code change proposal will not increase or decrease the cost of construction .

This provides clarity with NFPA 72 National Fire Alarm and Signaling Code

Internal ID: 286

F155-18

IFC: 907.6.6.2 (New), 907.6.6.2.1 (New) (IBC: [F] 907.6.6.2 (New), 907.6.6.2.1 (New))

Proponent: Michael O'Brian, Chair, representing FCAC (fcac@iccsafe.org); Shane Clary, Bay Alarm Company, representing Automaric Fire Alarm Association, Inc. (smclary@bayalarm.com); Jason Webb, Automatic Fire Alarm Association Codes & Standards Committee, representing Automatic Fire Alarm Association Codes & Standards Committee

2018 International Fire Code

Add new text as follows:

907.6.6.2 MIY Monitoring. Direct transmission of alarms associated with Monitor it Yourself (MIY) transmitters to a public safety answering point (PSAP) shall not be permitted unless approved by the fire code official.

907.6.6.2.1 Telephone calls. Requests for emergency service shall only be made via live voice to a public safety answering point (PSAP), unless approved by the fire code official.

Reason:

DIY Do it Yourself Fire Alarm Devices, and MIY Monitor it Yourself technologies practices are here today, and will only grow over the next 10+ years. The Fire Life Safety concern that this language addresses is the potential for a smoke detector/fire alarm system that today can easily communicate with our phones, tablets, watches and laptops; will also be able to contact DIRECTLY the Emergency Communication Center (911) without human interface. This will lead to an increase in unwanted alarm dispatches and place our first responders at risk.

This language will allow the technologies to advance and send information to the devices that a human can interface with, and they can make the determination to call 911.

This language will also allow the fire code official to allow advance technologies if they make that determination.

This proposal is submitted by the ICC Fire Code Action Committee (FCAC). The FCAC was established by the ICC Board of Directors to pursue opportunities to improve and enhance assigned International Codes with regard to fire safety and hazardous materials in new and existing buildings and facilities and the protection of life and property in wildland urban interface areas. In 2017 the Fire-CAC has held 3 open meetings. In addition, there were numerous conference calls, Regional Work Group and Task Group meetings for the current code development cycle, which included members of the committees as well as any interested parties, to discuss and debate the proposed changes. Related documentation and reports are posted on the FCAC website at: <https://www.iccsafe.org/codes-tech-support/cs/fire-code-action-committee-fcac/>

Cost Impact

The code change proposal will not increase or decrease the cost of construction .

This is a code clarification and alignment with NFPA 72 National Fire Alarm and Signaling Code

Internal ID: 367

F156-18

IFC: 907.8.4, 907.8.4.1

Proponent: Michael O'Brian, Chair, representing FCAC (fcac@iccsafe.org); Jason Webb, representing Automatic Fire Alarm Association Codes & Standards Committee (jwebb608@gmail.com)

2018 International Fire Code

907.8.3 Smoke detector sensitivity. Smoke detector sensitivity shall be checked within one year after installation and every alternate year thereafter. After the second calibration test, where sensitivity tests indicate that the detector has remained within its *listed* and marked sensitivity range (or 4-percent obscuration light gray smoke, if not marked), the length of time between calibration tests shall be permitted to be extended to not more than 5 years. Where the frequency is extended, records of detector-caused nuisance alarms and subsequent trends of these alarms shall be maintained. In zones or areas where nuisance alarms show any increase over the previous year, calibration tests shall be performed.

Delete without substitution:

~~**907.8.4 Sensitivity test method.** To verify that each smoke detector is within its *listed* and marked sensitivity range, it shall be tested using one of the following methods:~~

- ~~1. A calibrated test method.~~
- ~~2. The manufacturer's calibrated sensitivity test instrument.~~
- ~~3. *Listed* control equipment arranged for the purpose.~~
- ~~4. A smoke detector/control unit arrangement whereby the detector causes a signal at the control unit where the detector's sensitivity is outside its acceptable sensitivity range.~~
- ~~5. Another calibrated sensitivity test method acceptable to the *fire code official*.~~

~~Detectors found to have a sensitivity outside the *listed* and marked sensitivity range shall be cleaned and recalibrated or replaced.~~

~~Exceptions:~~

- ~~1. Detectors *listed* as field adjustable shall be permitted to be either adjusted within the *listed* and marked sensitivity range and cleaned and recalibrated or they shall be replaced.~~
- ~~2. This requirement shall not apply to single-station smoke alarms.~~

~~**907.8.4.1 Sensitivity testing device.** Smoke detector sensitivity shall not be tested or measured using a device that administers an unmeasured concentration of smoke or other aerosol into the detector.~~

Revise as follows:

~~**907.8.5**~~**907.8.4 Inspection, testing and maintenance.** The building *owner* shall be responsible to maintain the fire and life safety systems in an operable condition at all times. Service personnel shall meet the qualification requirements of NFPA 72 for inspection, testing and maintenance of such systems. Records of inspection, testing and maintenance shall be maintained.

Reason:

This Proposal seeks just eliminate the redundant language in the IFC that is in NFFA 72. Does NOT change any testing requirements, just points you towards NFPA 72 for the details.

This proposal is submitted by the ICC Fire Code Action Committee (FCAC). The FCAC was established by the ICC Board of Directors to pursue opportunities to improve and enhance assigned International Codes with regard to fire safety and hazardous materials in new and existing buildings and facilities and the protection of life and property in wildland urban interface areas. In 2017 the Fire-CAC has held 3 open meetings. In addition, there were numerous conference calls, Regional Work Group and Task Group meetings for the current code development cycle, which included members of the committees as well as any interested parties, to discuss and debate the proposed changes. Related documentation and reports are posted on the FCAC website at: <https://www.iccsafe.org/codes-tech-support/cs/fire-code-action-committee-fcac/>

Cost Impact

The code change proposal will not increase or decrease the cost of construction .

This change is just eliminating duplicated language that is in NFPA 72, the referenced document.

Internal ID: 269

F157-18

IFC: 907.8.6 (New)

Proponent: Michael O'Brian, Chair, representing FCAC (fcac@iccsafe.org); Richard Roberts, representing Honeywell (richard.roberts@systemsensor.com); Jason Webb, representing Automatic Fire Alarm Association Codes & Standards Committee (jwebb608@gmail.com)

2018 International Fire Code

Add new text as follows:

907.8.6 Problematic Systems. Where required by the fire code official, fire alarm systems that produce chronic, unwanted alarms shall be monitored with central station service in accordance with NFPA 72 requirements. A copy of the certificate, placard or other documentation issued by the organization that listed the central station, or the prime fire alarm system contractor, shall be made available to the fire code official upon request.

Reason:

This section is intended to address situations where fire alarm systems repeatedly create unwanted alarm signals. The determination of what constitutes chronic unwanted alarms is up to the fire code official to decide based on local policies and practices, such as local false alarm ordinances. By requiring central station service the fire alarm system now will be covered by an audit program administered by the company that listed the central station. Certified central station service has been shown to significantly reduce unwanted alarms.

This proposal is submitted by the ICC Fire Code Action Committee (FCAC). The FCAC was established by the ICC Board of Directors to pursue opportunities to improve and enhance assigned International Codes with regard to fire safety and hazardous materials in new and existing buildings and facilities and the protection of life and property in wildland urban interface areas. In 2017 the Fire-CAC has held 3 open meetings. In addition, there were numerous conference calls, Regional Work Group and Task Group meetings for the current code development cycle, which included members of the committees as well as any interested parties, to discuss and debate the proposed changes. Related documentation and reports are posted on the FCAC website at: <https://www.iccsafe.org/codes-tech-support/cs/fire-code-action-committee-fcac/>

Cost Impact

The code change proposal will not increase or decrease the cost of construction .

There is an approximate \$100 annual fee for certificates which includes the ongoing third party inspection. To clarify does not increase the cost of construction or installation, but when employed will cost the owner this additional amount for annual service.

Internal ID: 273

F158-18

IFC: 907.10, 907.10.1 (New)

Proponent: Thomas Daly, representing The Hospitality Security Consulting Group, LLC (Thomas.Daly@myhscg.com)

2018 International Fire Code

Revise as follows:

907.10 Smoke alarm maintenance. Smoke alarms shall be tested and maintained in accordance with the manufacturer's instructions. ~~Smoke alarms shall be replaced when they fail to respond to operability tests, or when they exceed 10 years from the date of manufacture, unless an earlier replacement is specified in the manufacturer's published instructions.~~

Add new text as follows:

907.10.1 Replacement. Newly installed smoke alarms shall be replaced, deemed construction, when they fail to respond to operability tests, or when they exceed 10 years from the date of manufacture, unless an earlier replacement is specified in the manufacturer's published instructions.

Reason:

The proposed changes will clarify the intent of the language by differentiating between maintenance (testing, cleaning, etc) and replacement (construction) and apply the replacement obligation to newly installed smoke alarms, as there is no corresponding language in Chapter 11 making this replacement obligation applicable to existing installations.

Cost Impact

The code change proposal will not increase or decrease the cost of construction .

The proposal will likely decrease the cost of operations. If this code change approved, the cost of operations would decrease as only smoke alarms installed on and after the adoption of the 2021 code, would be covered by the obligation for replacement at 10 years. Existing smoke alarms would not as there is no corresponding language in Chapter 11 (now or proposed) for existing construction. There are multiple occupancies affected and I cannot speak for all of them, but for lodging the decrease in costs we estimate at \$25 million per year, every year

Internal ID: 1207

F159-18

IFC: 908.3 (New) (IBC: [F] 908.3(New))

Proponent: Stephen DiGiovanni, representing self (sdigiovanni@clarkcountynv.gov)

2018 International Fire Code

Add new text as follows:

908.3 Fire alarm system interface. Where an emergency alarm system is interfaced with a building's fire alarm system, the signal produced at the fire alarm control unit shall be a supervisory signal.

Reason:

The code is silent about how to interface an emergency alarm system with a fire alarm system. The emergency alarm system may or may not require evacuation, but should not activate the fire alarm system. It is important to ensure the integrity of the fire alarm system, and to ensure that the fire alarm signal be reserved for fire emergencies. Where interface between different alarm systems is desired, such as may occur when providing off-site monitoring services, it is important to ensure that unwanted activations of the fire alarm system are avoided. By requiring the supervisory signal, the code clarifies what is intended when systems are interfaced, and provides an appropriate level of signal to monitoring facilities to ensure that corrective action is taken.

Cost Impact

The code change proposal will not increase or decrease the cost of construction .

This proposal will not change the cost of system installation, as it only addresses the internal programming of a fire alarm system when interfaced with an emergency alarm system.

Internal ID: 1067

F160-18

IFC: 909.12.1 (IBC[F] 909.12.1); IMC: 513.12.1

Proponent: John Kampmeyer, representing Self (jkamppe@gmail.com)

2018 International Fire Code

Revise as follows:

909.12.1 Verification. Control systems for mechanical smoke control systems shall include provisions for verification. Verification shall include positive confirmation of actuation, testing, manual override and the presence of power downstream of all disconnects. A preprogrammed weekly test sequence shall report abnormal conditions audibly, visually and by printed report. The preprogrammed weekly test shall operate all devices, equipment, and components used for smoke control.

Exception: Where verification of individual components tested through the preprogrammed weekly testing sequence will interfere with, and produce unwanted effects to, normal building operation, such individual components are permitted to be bypassed from the preprogrammed weekly testing, where *approved* by the *fire code official* and in accordance with both of the following:

1. Where the operation of components is bypassed from the preprogrammed weekly test, presence of power downstream of all disconnects shall be verified ~~weekly~~ continuously by a listed control unit that monitors all of the functions of the smoke control system.
2. Testing of all components bypassed from the preprogrammed weekly test shall be in accordance with Section 909.20.6.

2018 International Mechanical Code

Revise as follows:

[F] 513.12.1 Verification. Control systems for mechanical smoke control systems shall include provisions for verification. Verification shall include positive confirmation of actuation, testing, manual override and the presence of power downstream of all disconnects. A preprogrammed weekly test sequence shall report abnormal conditions audibly, visually and by printed report. The preprogrammed weekly test shall operate all devices, equipment and components used for smoke control.

Exception: Where verification of individual components tested through the preprogrammed weekly testing sequence will interfere with, and produce unwanted effects to, normal building operation, such individual components are permitted to be bypassed from the preprogrammed weekly testing, where *approved* by the building official and in accordance with both of the following:

1. Where the operation of components is bypassed from the preprogrammed weekly test, presence of power downstream of all disconnects shall be verified ~~weekly~~ continuously by a listed control ~~unit.~~ unit that monitors all of the functions of the smoke control system.
2. Testing of all components bypassed from the preprogrammed weekly test shall be in accordance with Section 909.20.6 of the International Fire Code.

Reason:

The weekly automatic test of dedicated smoke control systems (atrium exhaust, stair pressurization, etc) is detrimental to building in cold climates. Building owners are reluctant to introduce unconditioned air into the buildings.

By monitoring the smoke control system components and functions on a listed control panel connected to power supplies, end switches, disconnect switches, airflow switches, etc, the failure of any item will immediately register a fault condition on the smoke control panel and initiate a supervisory alarm on the fire alarm panel.

Cost Impact

The code change proposal will not increase or decrease the cost of construction .

This proposal does not affect the cost of smoke control systems since the monitoring required by this exception will be the same cost whether continuously or weekly. It also eliminates the need for a printer which is often not provided on smaller building systems which contain atria.

Internal ID: 303

F161-18

IFC 909.17 (IBC: [F] 909.17)

Proponent: Douglas Evans, DHE FPE LLC, representing DHE FPE LLC (dhefpe@gmail.com)

2018 International Fire Code

Revise as follows:

909.17 System response time. Smoke-control system activation shall be initiated immediately after receipt of an appropriate automatic or manual activation command. Smoke control systems shall activate individual components (such as dampers and fans) in the sequence necessary to prevent physical damage to the fans, dampers, ducts and other equipment. For purposes of smoke control, the fire ~~fighter's~~fighter's control panel response time shall be the same for automatic or manual smoke control action initiated from any other building control point. The total response time, including that necessary for detection, shutdown of operating equipment and smoke control system startup, shall allow for full operational mode to be achieved before the conditions in the space exceed the design smoke condition. Upon receipt of an alarm condition at the fire alarm control panel, fans, dampers and automatic doors shall have achieved their proper operating state and final status shall be indicated at the smoke control panel within 90 seconds. The system response time for each component and their sequential relationships shall be detailed in the required rational analysis and verification of their installed condition reported in the required final report.

Reason:

The code does not presently specify a time frame in which the smoke control system is required to configure and be fully operational. This decision is left open for debate. At times, designers have argued that fire department response times should dictate the duration in which the smoke control system should configure, which can be expected to take several minutes. As specified in the third sentence of 909.17, the time limitation also applies to manual activation from the fire-fighter's control panel. As such, a reasonable time frame for the smoke control system to be fully operational from either manual or automatic initiation should be specified in the code.

There are a number of time delays that are inherent in activation of smoke control systems. There is the delay between when the initiating device activates and when the panel registers an alarm condition. These delays can be inherent in the components or even programmed into the system. Sprinkler systems are allowed to have a delay up to 90 seconds to compensate for surges in the piping network.

The 90 second delay proposed herein is: after the fire alarm control panel indicates an alarm condition, the smoke control system is expected to be fully operational. This 90 second delay is based on the time it takes smoke dampers to configure and annunciate their status (open/closed). Section 8.1 of UL 555S, which governs smoke dampers, requires them to fully configure (open or close) within 75 seconds. The additional time (15 seconds for a total of 90 seconds) allows for delays in data transfer and confirmation, as well as ample time for all other components to be fully operational (e.g. fans).

With 90 seconds stipulated in the code, there is no confusion, or debate, as to what's expected. This time constraint for smoke control systems to configure and report proper status has been used throughout Southern Nevada, including the Las Vegas Strip, for almost 25 years and has not been shown to be a hardship.

Cost Impact

The code change proposal will not increase or decrease the cost of construction .

All components of a smoke control system can easily configure and report back to the smoke control panel within the allotted 90 seconds.

Internal ID: 1605

F162-18

IFC: [BF] 909.20 (New), [BF] 909.20.1 (New), [BF] 909.20.2 (New), [BF] 909.20.2.1 (New), [BF] 909.20.3 (New), [BF] 909.20.3.1 (New), [BF] 909.20.3.2 (New), [BF] 909.20.3.3 (New), [BF] 909.20.4 (New), [BF] 909.20.4.1 (New), [BF] 909.20.4.2 (New), [BF] 909.20.4.2.1 (New), [BF] 909.20.4.3 (New), [BF] 909.20.4.4 (New), [BF] 909.20.5 (New), [BF] 909.20.6 (New), [BF] 909.20.6.1 (New), [BF] 909.20.6.2 (New), [BF] 909.20.6.3 (New), 909.22, 909.22.1, 909.22.2, 909.22.3, 909.22.4, 909.22.5, 909.22.6, 909.6.3, 909.12.1, 909.19, 1023.3.1, 1023.11, 1023.11.2

Proponent: Kevin Scott, representing KH Scott & Associates LLC (khscottassoc@gmail.com)

2018 International Fire Code

Add new text as follows:

[BF] 909.20 Smokeproof enclosures. Where required by Section 1023.11, a smokeproof enclosure shall be constructed in accordance with this section. A smokeproof enclosure shall consist of an interior exit stairway or ramp that is enclosed in accordance with the applicable provisions of Section 1023 and an open exterior balcony or ventilated vestibule meeting the requirements of this section. Where access to the roof is required, such access shall be from the smokeproof enclosure where a smokeproof enclosure is required.

[BF] 909.20.1 Access. Access to the stairway or ramp shall be by way of a vestibule or an open exterior balcony. The minimum dimension of the vestibule shall be not less than the required width of the corridor leading to the vestibule but shall not have a width of less than 44 inches (1118 mm) and shall not have a length of less than 72 inches (1829 mm) in the direction of egress travel.

[BF] 909.20.2 Construction. The smokeproof enclosure shall be separated from the remainder of the building by not less than 2-hour fire barriers constructed in accordance with Section 707 of the International Building Code or horizontal assemblies constructed in accordance with Section 711 of the International Building Code, or both. Openings are not permitted other than the required means of egress doors. The vestibule shall be separated from the stairway or ramp by not less than 2-hour fire barriers constructed in accordance with Section 707 of the International Building Code or horizontal assemblies constructed in accordance with Section 711 of the International Building Code, or both. The open exterior balcony shall be constructed in accordance with the fire-resistance rating requirements for floor assemblies.

[BF] 909.20.2.1 Door closers. Doors in a smokeproof enclosure shall be self- or automatic closing by actuation of a smoke detector in accordance with Section 716.5.9.3 of the International Building Code and shall be installed at the floor-side entrance to the smokeproof enclosure. The actuation of the smoke detector on any door shall activate the closing devices on all doors in the smokeproof enclosure at all levels. Smoke detectors shall be installed in accordance with Section 907.3.

[BF] 909.20.3 Natural ventilation alternative. The provisions of Sections 909.20.3.1 through 909.20.3.3 shall apply to ventilation of smokeproof enclosures by natural means.

[BF] 909.20.3.1 Balcony doors. Where access to the stairway or ramp is by way of an open exterior balcony, the door assembly into the enclosure shall be a fire door assembly in accordance with Section 716 of the International Building Code.

[BF] 909.20.3.2 Vestibule doors. Where access to the stairway or ramp is by way of a vestibule, the door assembly into the vestibule shall be a fire door assembly complying with Section 716 of the International Building Code. The door assembly from the vestibule to the stairway shall have not less than a 20-minute fire protection rating complying with Section 716 of the International Building Code.

[BF] 909.20.3.3 Vestibule ventilation. Each vestibule shall have a minimum net area of 16 square feet (1.5 m²) of opening in a wall facing an outer court, yard or public way that is not less than 20 feet (6096 mm) in width.

[BF] 909.20.4 Mechanical ventilation alternative. The provisions of Sections 909.20.4.1 through 909.20.4.4 shall apply to ventilation of smokeproof enclosures by mechanical means.

[BF] 909.20.4.1 Vestibule doors. The door assembly from the building into the vestibule shall be a fire door assembly complying with Section 716.5.3 of the International Building Code. The door assembly from the vestibule to the stairway or ramp shall not have less than a 20-minute fire protection rating and shall meet the requirements for a smoke door assembly in accordance with Section 716.5.3 of the International Building Code. The door shall be installed

in accordance with NFPA 105.

[BF] 909.20.4.2 Vestibule ventilation. The vestibule shall be supplied with not less than one air change per minute and the exhaust shall be not less than 150 percent of supply. Supply air shall enter and exhaust air shall discharge from the vestibule through separate, tightly constructed ducts used only for that purpose. Supply air shall enter the vestibule within 6 inches (152 mm) of the floor level. The top of the exhaust register shall be located at the top of the smoke trap but not more than 6 inches (152 mm) down from the top of the trap, and shall be entirely within the smoke trap area. Doors in the open position shall not obstruct duct openings. Duct openings with controlling dampers are permitted where necessary to meet the design requirements, but dampers are not otherwise required.

[BF] 909.20.4.2.1 Engineered ventilation system. Where a specially engineered system is used, the system shall exhaust a quantity of air equal to not less than 90 air changes per hour from any vestibule in the emergency operation mode and shall be sized to handle three vestibules simultaneously. Smoke detectors shall be located at the floor-side entrance to each vestibule and shall activate the system for the affected vestibule. Smoke detectors shall be installed in accordance with Section 907.3.

[BF] 909.20.4.3 Smoke trap. The vestibule ceiling shall be not less than 20 inches (508 mm) higher than the door opening into the vestibule to serve as a smoke and heat trap and to provide an upward-moving air column. The height shall not be decreased unless approved and justified by design and test.

[BF] 909.20.4.4 Stairway or ramp shaft air movement system. The stairway or ramp shaft shall be provided with a dampered relief opening and supplied with sufficient air to maintain a minimum positive pressure of 0.10 inch of water (25 Pa) in the shaft relative to the vestibule with all doors closed.

[BF] 909.20.5 Stairway and ramp pressurization alternative. Where the building is equipped throughout with an automatic sprinkler system in accordance with Section 903.3.1.1, the vestibule is not required, provided that each interior exit stairway or ramp is pressurized to not less than 0.10 inch of water (25 Pa) and not more than 0.35 inches of water (87 Pa) in the shaft relative to the building measured with all interior exit stairway and ramp doors closed under maximum anticipated conditions of stack effect and wind effect.

[BF] 909.20.6 Ventilating equipment. The activation of ventilating equipment required by the alternatives in Sections 909.20.4 and 909.20.5 shall be by smoke detectors installed at each floor level at an approved location at the entrance to the smokeproof enclosure. When the closing device for the stairway and ramp shaft and vestibule doors is activated by smoke detection or power failure, the mechanical equipment shall activate and operate at the required performance levels. Smoke detectors shall be installed in accordance with Section 907.3.

[BF] 909.20.6.1 Ventilation systems. Smokeproof enclosure ventilation systems shall be independent of other building ventilation systems. The equipment, control wiring, power wiring and ductwork shall comply with one of the following:

1. Equipment, control wiring, power wiring and ductwork shall be located exterior to the building and directly connected to the smokeproof enclosure or connected to the smokeproof enclosure by ductwork enclosed by not less than 2-hour fire barriers constructed in accordance with Section 707 of the International Building Code or horizontal assemblies constructed in accordance with Section 711 of the International Building Code, or both.
2. Equipment, control wiring, power wiring and ductwork shall be located within the smokeproof enclosure with intake or exhaust directly from and to the outside or through ductwork enclosed by not less than 2-hour fire barriers constructed in accordance with Section 707 of the International Building Code or horizontal assemblies constructed in accordance with Section 711 of the International Building Code, or both.
3. Equipment, control wiring, power wiring and ductwork shall be located within the building if separated from the remainder of the building, including other mechanical equipment, by not less than 2-hour fire barriers constructed in accordance with Section 707 of the International Building Code or horizontal assemblies constructed in accordance with Section 711 of the International Building Code, or both.

Exceptions: Control wiring and power wiring located outside of a 2-hour fire barrier construction shall be protected using any one of the following methods:

1. Cables used for survivability of required critical circuits shall be listed in accordance with UL 2196 and shall have a fire-resistance rating of not less than 2 hours.

2. Where encased with not less than 2 inches (51 mm) of concrete.
3. Electrical circuit protective systems shall have a fire-resistance rating of not less than 2 hours. Electrical circuit protective systems shall be installed in accordance with their listing requirements.

[BF] 909.20.6.2 Standby power. Mechanical vestibule and stairway and ramp shaft ventilation systems and automatic fire detection systems shall be provided with standby power in accordance with Section 604.

[BF] 909.20.6.3 Acceptance and testing. Before the mechanical equipment is approved, the system shall be tested in the presence of the building official to confirm that the system is operating in compliance with these requirements.

Revise as follows:

~~909.20.909.22~~ **Maintenance.** Smoke control systems shall be maintained to ensure to a reasonable degree that the system is capable of controlling smoke for the duration required. The system shall be maintained in accordance with the manufacturer's instructions and Sections ~~909.20.1~~ 909.22.1 through ~~909.20.6~~ 909.22.6.

~~909.20.1~~ 909.22.1 **Schedule.** A routine maintenance and operational testing program shall be initiated immediately after the smoke control system has passed the acceptance tests. A written schedule for routine maintenance and operational testing shall be established.

~~909.20.2~~ 909.22.2 **Records.** Records of smoke control system testing and maintenance shall be maintained. The record shall include the date of the maintenance, identification of the servicing personnel and notification of any unsatisfactory condition and the corrective action taken, including parts replaced.

~~909.20.3~~ 909.22.3 **Testing.** Operational testing of the smoke control system shall include all equipment such as initiating devices, fans, dampers, controls, doors and windows.

~~909.20.4~~ 909.22.4 **Dedicated smoke control systems.** Dedicated smoke control systems shall be operated for each control sequence semiannually. The system shall be tested under standby power conditions.

~~909.20.5~~ 909.22.5 **Nondedicated smoke control systems.** Nondedicated smoke control systems shall be operated for each control sequence annually. The system shall be tested under standby power conditions.

~~909.20.6~~ 909.22.6 **Components bypassing weekly test.** Where components of the smoke control system are bypassed by the preprogrammed weekly test required by Section 909.12.1, such components shall be tested semiannually. The system shall be tested under standby power conditions.

909.6.3 Pressurized stairways and elevator hoistways. Where stairways or elevator hoistways are pressurized, such pressurization systems shall comply with Section 909 as smoke control systems, in addition to the requirements of ~~Section 909.21 of this code and Section 909.20 of the International Building Code.~~ Sections 909.20 and 909.21.

909.12.1 Verification. Control systems for mechanical smoke control systems shall include provisions for verification. Verification shall include positive confirmation of actuation, testing, manual override and the presence of power downstream of all disconnects. A preprogrammed weekly test sequence shall report abnormal conditions audibly, visually and by printed report. The preprogrammed weekly test shall operate all devices, equipment, and components used for smoke control.

Exception: Where verification of individual components tested through the preprogrammed weekly testing sequence will interfere with, and produce unwanted effects to, normal building operation, such individual components are permitted to be bypassed from the preprogrammed weekly testing, where *approved* by the *fire code official* and in accordance with both of the following:

1. Where the operation of components is bypassed from the preprogrammed weekly test, presence of power downstream of all disconnects shall be verified weekly by a listed control unit.
2. Testing of all components bypassed from the preprogrammed weekly test shall be in accordance with Section ~~909.20.6~~ 909.22.6.

909.19 System acceptance. Buildings, or portions thereof, required by this code to comply with this section shall not be issued a certificate of occupancy until such time that the *fire code official* determines that the provisions of this

section have been fully complied with and that the fire department has received satisfactory instruction on the operation, both automatic and manual, of the system and a written maintenance program complying with the requirements of Section ~~909.20.1~~ 909.22.1 has been submitted and *approved* by the *fire code official*.

Exception: In buildings of phased construction, a temporary certificate of occupancy, as *approved* by the *fire code official*, shall be allowed, provided that those portions of the building to be occupied meet the requirements of this section and that the remainder does not pose a significant hazard to the safety of the proposed occupants or adjacent buildings.

[BE] 1023.3.1 Extension. Where *interior exit stairways* and *ramps* are extended to an *exit discharge* or a *public way* by an *exit passageway*, the *interior exit stairway* and *ramp* shall be separated from the *exit passageway* by a *fire barrier* constructed in accordance with Section 707 of the International Building Code or a horizontal assembly constructed in accordance with Section 711 of the International Building Code, or both. The *fire-resistance rating* shall be not less than that required for the *interior exit stairway* and *ramp*. A *fire door* assembly complying with Section 716 of the International Building Code shall be installed in the *fire barrier* to provide a *means of egress* from the *interior exit stairway* and *ramp* to the *exit passageway*. Openings in the *fire barrier* other than the *fire door* assembly are prohibited. Penetrations of the *fire barrier* are prohibited.

Exceptions:

1. Penetrations of the *fire barrier* in accordance with Section 1023.5 shall be permitted.
2. Separation between an *interior exit stairway* or *ramp* and the *exit passageway* extension shall not be required where there are no openings into the *exit passageway* extension.
3. Separation between an *interior exit stairway* or *ramp* and the *exit passageway* extension shall not be required where the *interior exit stairway* and the *exit passageway* extension are pressurized in accordance with Section 909.20.5 of the International Building Code.

[BE] 1023.11 Smokeproof enclosures. Where required by Building Code, *interior exit stairways* and *ramps* shall be smokeproof enclosures in accordance with Section 909.20 of the International Building Code .

[BE] 1023.11.2 Enclosure access. Access to the *stairway* or *ramp* within a *smokeproof enclosure* shall be by way of a vestibule or an open exterior balcony.

Exception: Access is not required by way of a vestibule or exterior balcony for *stairways* and *ramps* using the pressurization alternative complying with Section 909.20.5 of the International Building Code.

Reason:

Section 909.20 does not exist in the 2018 IFC, although, these sections have been in the IBC for several editions. It is generally considered that Chapter 9 in the IFC is the same as Chapter 9 in the IBC.

Adding this text into the IFC provides correlation with the IBC and enhances consistent application, interpretation, and enforcement. The is no substantive change in the code language.

The IFC sections referencing these items are revised to refer to the new sections in the IFC.

The IBC sections referencing IFC sections are revised to refer to the new sections in the IFC.

The [BF] symbol is added for each section since amendments to these provisions are processed through the IBC Fire Safety Code Development Committee.

Cost Impact

The code change proposal will not increase or decrease the cost of construction .

This is a format change and does not affect application of the code requirements.

Internal ID: 1485

F163-18

IFC: 909.6.3, 909.22 (New), 909.22.1 (New), 909.22.1.1 (New), 909.22.1.2 (New), 909.22.1.3 (New), 909.22.1.3.1 (New), 909.22.1.3.2 (New), 909.22.1.3.3 (New), 909.22.2 (New), 909.22.3 (New), 909.22.4 (New), 909.22.5 (New), 909.22.6 (New), 909.22.7 (New); IBC: 909.6.3

Proponent: Bob Morgan, Fort Worth Fire Department, representing Fort Worth Fire Department

2018 International Fire Code

Revise as follows:

909.6.3 Pressurized stairways and elevator hoistways. Where stairways and ramps or elevator hoistways are pressurized, such pressurization systems shall comply with Section 909 as smoke control systems, in addition to the requirements of ~~Section Sections~~ 909.21 ~~of this code and Section 909.20 of the International Building Code and 909.22,~~ as applicable.

Add new text as follows:

909.22 Stairway and Ramp Pressurization Alternative.

Where the stairway and ramp pressurization alternative is chosen for compliance with Building Code requirements for a smokeproof enclosure, interior exit stairways and ramps shall be pressurized to a minimum of 0.10 inches of water (25 Pa) and a maximum of 0.35 inches of water (87 Pa) in the shaft relative to the building measured with all interior exit stairway and ramp doors closed under maximum anticipated conditions of stack effect and wind effect. Such pressurization systems shall also comply with Sections 909.22.1 through 909.22.7.

909.22.1 Ventilating equipment. The activation of ventilating equipment for the stair and ramp pressurization system shall be by smoke detectors installed at each floor level at an approved location at the entrance to the smokeproof enclosure. When the closing device for the stairway and ramp shaft and vestibule doors is activated by smoke detection or power failure, the mechanical equipment shall activate and operate at the required performance levels. Smoke detectors shall be installed in accordance with Section 907.3.

909.22.1.1 Ventilation Systems. Smokeproof enclosure ventilation systems shall be independent of other building ventilation systems. The equipment, control wiring, power wiring and ductwork shall comply with one of the following:

1. Equipment, control wiring, power wiring and ductwork shall be located exterior to the building and directly connected to the smokeproof enclosure or connected to the smokeproof enclosure by ductwork enclosed by not less than 2-hour fire barriers constructed in accordance with Section 707 of the Building Code or horizontal assemblies constructed in accordance with Section 711 of the Building Code, or both.
2. Equipment, control wiring, power wiring and ductwork shall be located within the smokeproof enclosure with intake or exhaust directly from and to the outside or through ductwork enclosed by not less than 2-hour barriers constructed in accordance with Section 707 of the Building Code or horizontal assemblies constructed in accordance with Section 711 of the Building Code, or both.
3. Equipment, control wiring, power wiring and ductwork shall be located within the building if separated from the remainder of the building, including other mechanical equipment, by not less than 2-hour fire barriers constructed in accordance with Section 707 of the Building Code or horizontal assemblies constructed in accordance with Section 711 of the Building Code, or both
Exceptions:
 1. Control wiring and power wiring utilizing a 2-hour rated cable or cable system.
 2. Where encased with not less than 2 inches (51 mm) of concrete.
 3. Control wiring and power wiring protected by a listed electrical circuit protective systems with a fire-resistance rating of not less than 2 hours.

909.22.1.2 Ducts for system. Any duct system that is part of the pressurization system shall be protected with the same fire-resistance rating as required for the smokeproof enclosure.

909.22.1.3 Fan system. The fan system provided for the pressurization system shall be as required by Sections 909.22.1.3.1 through 909.22.1.3.3.

909.22.1.3.1 Fire resistance. Where located within the building, the fan system that provides the pressurization shall be protected with the same fire-resistance rating required for the smokeproof enclosure.

909.22.1.3.2 Smoke detection. The fan system shall be equipped with a smoke detector that will automatically shut down the fan system when smoke is detected within the system.

909.22.1.3.3 Separate systems. A separate fan system shall be used for each smokeproof enclosure.

909.22.2 Standby power. The pressurization system shall be provided with standby power in accordance with Section 1203.

909.22.3 Testing. Testing for performance shall be required in accordance with Section 909.18.8. System acceptance shall be in accordance with Section 909.19.

909.22.4 Marking and identification. Detection and control systems shall be marked in accordance with Section 909.14.

909.22.5 Control diagrams. Control diagrams shall be provided in accordance with Section 909.15.

909.22.6 Control panel. A control panel complying with Section 909.16 shall be provided.

909.22.7 System response time. Stairway and ramp pressurization systems shall comply with the requirements for smoke control system response time in Section 909.17.

2018 International Building Code

Revise as follows:

[F] 909.6.3 Pressurized stairways and elevator hoistways. Where stairways and ramps or elevator hoistways are pressurized, such pressurization systems shall comply with Section 909 as smoke control systems, in addition to the requirements of Sections 909.20 of this code and 909.21 and 909.22, as applicable, of the International Fire Code.

Reason:

The intent with this change is to simply duplicate the requirements for a stairway and ramp pressurization systems from the Building Code to the Fire Code. This change is not intended to make substantive changes to the requirements, but rather to provide the fire code official with the requirements for such systems in the Fire Code for enforcement purposes relative to the Smoke Control Permit required for such systems and 909.6.3, both of which were introduced to the code in the 2015 edition. The elevator pressurization requirements were duplicated in a similar fashion in the 2015 edition of the code, but the stairway pressurization requirements were not, resulting in some confusion.

The change was previously proposed to the 2018 edition of the IFC to no avail, so I am attempting one last time to get this put into the IFC because it doesn't make sense to have elevator pressurization requirements in the IFC and not stairway pressurization requirements when a smoke control permit is clearly required for such systems. The proposal has been arranged to more closely match the arrangement of the elevator pressurization requirements in hopes of satisfying the committee's past concerns.

Cost Impact

The code change proposal will not increase or decrease the cost of construction .

This is simply a duplication of the requirements from the Building Code into the Fire Code, so there should be no increase in the cost of construction, as such.

Internal ID: 1048

F164-18

IFC: 910.2.2 (IBC: [F] 910.2.2)

Proponent: Mark Chubb, Telgian Corp., representing Telgian Corp. (mchubb@telgian.com)

2018 International Fire Code

Revise as follows:

910.2.2 High-piled combustible storage. Smoke and heat removal required by Table 3206.2 for buildings and portions thereof containing high-piled combustible storage shall be installed in accordance with Section 910.3 in un-sprinklered buildings. In buildings and portions thereof containing high-piled combustible storage equipped throughout with an *automatic sprinkler system* using standard-spray or control mode density-area (CMDA) sprinklers in accordance with Section 903.3.1.1, a smoke and heat removal system shall be installed in accordance with Section 910.3 or 910.4. Smoke and heat removal systems shall not be required in buildings equipped throughout with an automatic sprinkler system using Early-Suppression Fast-Response (ESFR) or Control-Mode Specific-Application (CMSA) sprinklers in accordance with Section 903.3.1.1. In occupied portions of a building equipped throughout with an *automatic sprinkler system* in accordance with Section 903.3.1.1 where the upper surface of the story is not a roof assembly, a mechanical smoke removal system in accordance with Section 910.4 shall be installed.

Reason:

The proposed change is consistent with Table 3206.1, Note h., which exempts high-piled storage protected by ESFR or CMSA sprinklers from smoke and heat removal requirements. Adding this language to section 910.2.2 seeks to improve consistency in application and interpretation of these code requirements.

Cost Impact

The code change proposal will not increase or decrease the cost of construction .

This change recognizes the existing exception for smoke and heat venting in Table 3206.1, Note h. in buildings protected by ESFR or CMSA sprinklers.

Internal ID: 150

F165-18

IBC: 910.3.4 (New) (IBC: [F] 910.3.4 (New))

Proponent: Michael O'Brian, Chair, representing FCAC (fcac@iccsafe.org)

2018 International Fire Code

Add new text as follows:

910.3.4 Vent Operation. Smoke and heat vents shall be capable of being operated by approved automatic and manual means.

Reason:

Several code changes have revised the smoke and heat vent requirements over the past several cycles. Most recently, F195-13 removed much of the requirements in the IFC/IBC regarding smoke and heat vents and replaced them with a requirement for compliance with UL 793 or FM 4430 and a reference to NFPA 204 for maintenance, along with a significant change to the number of smoke and heat vents and mechanical smoke removal requirements.

One of the requirements that is no longer found in the IFC is the requirement that smoke and heat vents be capable of both automatic and manual operation. While this requirement is found in Section 5.3.5 of NFPA 204 Smoke and Heat Venting, the standard is not referenced for installation. But even if it was referenced for installation, this requirement would likely still be missed since the UL test standard does not require a manual release. The UL standard states that **IF** a manual release is provided, it will be tested. But the reality is that you can find UL listed smoke and heat vents with, or without, a manual release.

Placing this requirement into the code brings it to the attention of the designer, plan reviewer, and inspector

The manual release is critical since the smoke and heat vent most likely will not open automatically in a sprinklered building, if the sprinkler system is adequately cooling the ceiling temperatures. Therefore, the firefighters must have the ability to open the smoke and heat vents manually.

This proposal is submitted by the ICC Fire Code Action Committee (FCAC). The FCAC was established by the ICC Board of Directors to pursue opportunities to improve and enhance assigned International Codes with regard to fire safety and hazardous materials in new and existing buildings and facilities and the protection of life and property in wildland urban interface areas. In 2017 the Fire-CAC has held 3 open meetings. In addition, there were numerous conference calls, Regional Work Group and Task Group meetings for the current code development cycle, which included members of the committees as well as any interested parties, to discuss and debate the proposed changes. Related documentation and reports are posted on the FCAC website at: <https://www.iccsafe.org/codes-tech-support/cs/fire-code-action-committee-fcac/>

Cost Impact

The code change proposal will not increase or decrease the cost of construction .

This is standard for NFPA 2014 installations and was inadvertently removed in the sweeping changes made to Section 910 in 2015.

Internal ID: 277

F166-18

IFC: 910.3.4 (New) (IBC: [F] 910.3.4 (New))

Proponent: Stephen DiGiovanni, representing self (sdigiovanni@clarkcountynv.gov)

2018 International Fire Code

Add new text as follows:

910.3.4 Fusible link temperature rating. Where vents are installed in areas provided with automatic fire sprinklers and the vents operate by fusible link, the fusible link shall have a temperature rating of 360° F (182° C).

Reason:

There have been studies that show that draft curtains and smoke and heat vents can have negative consequence on fire sprinkler performance in storage buildings. One item that is not addressed within the IFC is related to the acceptable temperature rating of fusible links used to operate smoke and heat vents. At least one legacy code (UFC) required this link rating to be between 350° F and 400° F, and FM guidance indicates 360° F is an appropriate temperature rating. The proposal here is to use the 360° F temperature rating, in order to ensure that the fire sprinklers activate prior to opening of the smoke and heat vents.

Cost Impact

The code change proposal will increase the cost of construction .

This proposal may increase costs of construction in order to accommodate the costs with changing fusible links to meet this proposed requirement.

Internal ID: 1069

F167-18

IFC: 910.4.3.1 (IBC: [F] 910.4.3.1)

Proponent: Bob Morgan, Fort Worth Fire Department, representing Fort Worth Fire Department

2018 International Fire Code

Revise as follows:

910.4.3.1 Makeup air. Makeup air openings shall be provided within 6 feet (1829 mm) of the floor level. Operation of makeup air openings shall be ~~manual or~~ automatic. The minimum gross area of makeup air inlets shall be 8 square feet per 1,000 cubic feet per minute (0.74 m² per 0.4719 m³/s) of smoke exhaust.

Reason:

Allowing makeup air to be manually activated results in additional personnel being required to accommodate running around the building to open doors, louvers, etc., as well as a knowledge as to the number and location of which doors to open to accommodate the makeup air needs of the exhaust system. Automatically activating the makeup air saves significant time for responders to be able to immediately activate the system and have it function properly. It is understood that many believe these systems are only utilized in post-fire scenarios, but that is not always the case.

Cost Impact

The code change proposal will increase the cost of construction .

This proposal would eliminate the option of manually activating makeup air, i.e. manually opening doors around the building, in favor of requiring automatically activated makeup air when the mechanical smoke exhaust system is activated.

Internal ID: 1298

F168-18

IFC: 911.1, 911.4 (New), TABLE 911.1, TABLE 2204.1, 80; IBC: TABLE 414.5.1, ordinal

Proponent: Michael O'Brian, Chair, representing FCAC (fcac@iccsafe.org); Robert Davidson, Davidson Code Concepts, LLC, representing Tesla, USA (rjd@davidsoncodeconcepts.com)

2018 International Fire Code

Revise as follows:

911.1 General. Explosion control shall be provided in the following locations:

1. Where a structure, room or space is occupied for purposes involving explosion hazards as identified in Table 911.1.
2. Where quantities of hazardous materials specified in Table 911.1 exceed the maximum allowable quantities in Table 5003.1.1(1).

Such areas shall be provided with explosion (*deflagration*) venting, explosion (*deflagration*) prevention systems or *barricades* in accordance with this section and NFPA 68, NFPA 69, or NFPA 495 as applicable. *Deflagration* venting shall not be utilized as a means to protect buildings from *detonation* hazards.

Add new text as follows:

911.4 Deflagration venting. Deflagration venting shall be of an approved type and installed in accordance with the provisions of this code and NFPA 68.

Revise as follows:

**TABLE 911.1
EXPLOSION CONTROL REQUIREMENTS^f**

MATERIAL	CLASS	EXPLOSION CONTROL METHODS	
		Barricade construction	Explosion (deflagration) venting or explosion (deflagration) prevention systems
Hazard Category			
Combustible dusts ^a	—	Not required	Required
Cryogenic fluids	Flammable	Not required	Required
Explosives	Division 1.1	Required	Not required
	Division 1.2	Required	Not required
	Division 1.3	Not required	Required
	Division 1.4	Not required	Required
	Division 1.5	Required	Not required
	Division 1.6	Required	Not required
Flammable gas	Gaseous	Not required	Required
	Liquefied	Not required	Required
Flammable liquids	IA ^b	Not required	Required
	IB ^c	Not required	Required
Organic peroxides	Unclassified detonable	Required	Not permitted
	I	Required	Not permitted
Oxidizer liquids and solids	4	Required	Not permitted
Pyrophoric	Gases	Not required	Required
Unstable (reactive)	4	Required	Not permitted
	3 detonable	Required	Not permitted
	3 nondetonable	Not required	Required
Water-reactive liquids and solids	3	Not required	Required
	2 ^e	Not required	Required
Special Uses			
Acetylene generator rooms	—	Not required	Required
<u>Energy storage systems^d</u>	—	<u>Not Required</u>	<u>Required</u>
Grain processing	—	Not required	Required
Liquefied petroleum gas distribution facilities	—	Not required	Required
Where explosion hazards exist ^d	Detonation	Required	Not permitted
	Deflagration	Not required	Required

- a. Combustible dusts that are generated during manufacturing or processing. See definition of "Combustible dust" in Chapter 2.
- b. Storage or use.
- c. In open use or dispensing.
- d. Rooms containing dispensing and use of hazardous materials where an explosive environment can occur because of the characteristics or nature of the hazardous materials or as a result of the dispensing or use process.
- e. A method of explosion control shall be provided where Class 2 water-reactive materials can form potentially explosive mixtures.
- f. Explosion venting is not required for Group H-5 Fabrication Areas complying with Chapter 27 and the International Building Code.
- g. Where explosion control is required in Section 1206.

Add new text as follows:

**TABLE 2204.1
SPECIFIC HAZARDS STANDARDS**

NFPA 68	Standard on Explosion Protection by Deflagration Venting
---------	--

Add new standard(s) follows:

NFPA

National Fire Protection Association
1 Batterymarch Park
Quincy MA 02169-7471

68—13:

Standard on Explosion Protection by Deflagration Venting

2018 International Building Code

**[F] TABLE 414.5.1
EXPLOSION CONTROL REQUIREMENTS^{a, h}**

MATERIAL	CLASS	EXPLOSION CONTROL METHODS	
		Barricade construction	Explosion (deflagration) venting or explosion (deflagration) prevention systems ^b
HAZARD CATEGORY			
Combustible dusts ^c	—	Not Required	Required
Cryogenic flammables	—	Not Required	Required
Explosives	Division 1.1	Required	Not Required
	Division 1.2	Required	Not Required
	Division 1.3	Not Required	Required
	Division 1.4	Not Required	Required
	Division 1.5	Required	Not Required
	Division 1.6	Required	Not Required
Flammable gas	Gaseous	Not Required	Required
	Liquefied	Not Required	Required
Flammable liquid	IA ^d	Not Required	Required
	IB ^e	Not Required	Required
Organic peroxides	U	Required	Not Permitted
	I	Required	Not Permitted
Oxidizer liquids and solids	4	Required	Not Permitted
Pyrophoric gas	—	Not Required	Required
Unstable (reactive)	4	Required	Not Permitted
	3 Detonable	Required	Not Permitted
	3 Nondetonable	Not Required	Required
Water-reactive liquids and solids	3	Not Required	Required
	2 ^g	Not Required	Required
SPECIAL USES			
Acetylene generator rooms	—	Not Required	Required
<u>Energy Storage Systemsⁱ</u>		<u>Not Required</u>	<u>Required</u>
Grain processing	—	Not Required	Required
Liquefied petroleum gas-distribution facilities	—	Not Required	Required
Where explosion hazards exist ^f	Detonation	Required	Not Permitted
	Deflagration	Not Required	Required

- a. See Section 414.1.3.
- b. See the International Fire Code.
- c. As generated during manufacturing or processing.
- d. Storage or use.
- e. In open use or dispensing.
- f. Rooms containing dispensing and use of hazardous materials where an explosive environment can occur because of the characteristics or nature of the hazardous materials or as a result of the dispensing or use process.
- g. A method of explosion control shall be provided where Class 2 water-reactive materials can form potentially explosive mixtures.
- h. Explosion venting is not required for Group H-5 fabrication areas complying with Section 415.11.1 and the International Fire Code-
- i. Where explosion control is required in Section 1206.

Add new standard(s) follows:

NFPA

National Fire Protection Association
1 Batterymarch Park
Quincy MA 02169-7471

68-13:

Standard on Explosion Protection by Deflagration Venting

Reason:

Lithium-ion battery explosions have been occurring on a regular basis with a variety of products. These events are likely attributed to the release of flammable gases from batteries cells that vent flammable gases during thermal runaway and other off-normal conditions. This proposal provides correlation with a rewrite of Section 1206 ESS requirements. Specifically new ESS explosion control requirements in Table 1206.6 and Section 1206.6.4 in the International Fire Code and [F] Table 414.5.1 of the International Building Code. The proposal also adds appropriate references to the NFPA 68 Standard on Explosion Protection by Deflagration Venting to add additional requirements and guidance on the installation of deflagration venting.

This proposal is submitted by the ICC Fire Code Action Committee (FCAC). The FCAC was established by the ICC Board of Directors to pursue opportunities to improve and enhance assigned International Codes with regard to fire safety and hazardous materials in new and existing buildings and facilities and the protection of life and property in wildland urban interface areas. In 2017 the Fire-CAC has held 3 open meetings. In addition, there were numerous conference calls, Regional Work Group and Task Group meetings for the current code development cycle, which included members of the committees as well as any interested parties, to discuss and debate the proposed changes. Related documentation and reports are posted on the FCAC website at: <https://www.iccsafe.org/codes-tech-support/cs/fire-code-action-committee-fcac/>

Cost Impact

The code change proposal will increase the cost of construction .

The cost of construction will increase if explosion control is required, but that increase is not triggered by this proposal, but by the proposal that rewrites Section 1206.

Analysis: A review of the standard proposed for inclusion in the code, NFPA 68—13, with regard to the ICC criteria for referenced standards (Section 3.6 of CP#28) will be posted on the ICC website on or before April 2, 2018.

Internal ID: 1997

F169-18

IFC: TABLE 911.1 (IBC: [F] TABLE 414.5.1)

Proponent: Geoffrey Raifsnider, Global Finishing Solutions, representing Self

2018 International Fire Code

**TABLE 911.1
EXPLOSION CONTROL REQUIREMENTS^f**

MATERIAL	CLASS	EXPLOSION CONTROL METHODS	
		Barricade construction	Explosion (deflagration) venting or explosion (deflagration) prevention systems
Hazard Category			
Combustible dusts ^a	—	Not required	Required
Cryogenic fluids	Flammable	Not required	Required
Explosives	Division 1.1	Required	Not required
	Division 1.2	Required	Not required
	Division 1.3	Not required	Required
	Division 1.4	Not required	Required
	Division 1.5	Required	Not required
	Division 1.6	Required	Not required
Flammable gas	Gaseous	Not required	Required
	Liquefied	Not required	Required
Flammable liquids	IA ^b	Not required	Required
	IB^c	Not Required	Required
Organic peroxides	Unclassified detonable	Required	Not permitted
	I	Required	Not permitted
Oxidizer liquids and solids	4	Required	Not permitted
Pyrophoric	Gases	Not required	Required
Unstable (reactive)	4	Required	Not permitted
	3 detonable	Required	Not permitted
	3 nondetonable	Not required	Required
Water-reactive liquids and solids	3	Not required	Required
	2 ^e	Not required	Required
Special Uses			
Acetylene generator rooms	—	Not required	Required
Grain processing	—	Not required	Required
Liquefied petroleum gas distribution facilities	—	Not required	Required
Where explosion hazards exist ^d	Detonation	Required	Not permitted
	Deflagration	Not required	Required

2018 International Building Code

**[F] TABLE 414.5.1
EXPLOSION CONTROL REQUIREMENTS^{a, h}**

MATERIAL	CLASS	EXPLOSION CONTROL METHODS	
		Barricade construction	Explosion (deflagration) venting or explosion (deflagration) prevention systems ^b
HAZARD CATEGORY			
Combustible dusts ^c	—	Not Required	Required
Cryogenic flammables	—	Not Required	Required
Explosives	Division 1.1	Required	Not Required
	Division 1.2	Required	Not Required
	Division 1.3	Not Required	Required
	Division 1.4	Not Required	Required
	Division 1.5	Required	Not Required
	Division 1.6	Required	Not Required
Flammable gas	Gaseous	Not Required	Required
	Liquefied	Not Required	Required
Flammable liquid	IA ^d	Not Required	Required
	IB^e	Not Required	Required
Organic peroxides	U	Required	Not Permitted
	I	Required	Not Permitted
Oxidizer liquids and solids	4	Required	Not Permitted
Pyrophoric gas	—	Not Required	Required
Unstable (reactive)	4	Required	Not Permitted
	3 Detonable	Required	Not Permitted
	3 Nondetonable	Not Required	Required
Water-reactive liquids and solids	3	Not Required	Required
	2 ^g	Not Required	Required
SPECIAL USES			
Acetylene generator rooms	—	Not Required	Required
Grain processing	—	Not Required	Required
Liquefied petroleum gas-distribution facilities	—	Not Required	Required
Where explosion hazards exist ^f	Detonation	Required	Not Permitted
	Deflagration	Not Required	Required

- a. See Section 414.1.3.
- b. See the International Fire Code.
- c. As generated during manufacturing or processing.
- d. Storage or use.
- e. In open use or dispensing.
- f. Rooms containing dispensing and use of hazardous materials where an explosive environment can occur because of the characteristics or nature of the hazardous materials or as a result of the dispensing or use process.
- g. A method of explosion control shall be provided where Class 2 water-reactive materials can form potentially explosive mixtures.
- h. Explosion venting is not required for Group H-5 fabrication areas complying with Section 415.11.1 and the International Fire Code.

Reason:

This proposed change brings this table in alignment with the current edition of NFPA 30

Cost Impact

The code change proposal will decrease the cost of construction .

Elimination of deflagration venting or deflagration prevention system for enclosures used for open use or dispensing will reduce the cost of construction.

Internal ID: 2310

F170-18

IFC: TABLE 911.1; IBC: [F] TABLE 414.5.1

Proponent: Ellie Klausbruckner, representing Klausbruckner & Associates, Inc. (ek@klausbruckner.com); Kevin Scott, representing KH Scott & Associates LLC (khscottassoc@gmail.com)

2018 International Fire Code

Revise as follows:

**TABLE 911.1
EXPLOSION CONTROL REQUIREMENTS^f**

MATERIAL	CLASS	EXPLOSION CONTROL METHODS	
		Barricade construction	Explosion (deflagration) venting or explosion (deflagration) prevention systems
Hazard Category			
Combustible dusts ^a	—	Not required	Required
Cryogenic fluids	Flammable	Not required	Required
Explosives	Division 1.1	Required	Not required
	Division 1.2	Required	Not required
	Division 1.3	Not required	Required
	Division 1.4	Not required	Required
	Division 1.5	Required	Not required
	Division 1.6	Required	Not required
Flammable gas	Gaseous	Not required	Required
	Liquefied	Not required	Required
Flammable liquids	IA ^b	Not required	Required
	IB ^c	Not required	Required
Organic peroxides	Unclassified detonable	Required	Not permitted
	I	Required	Not permitted
Oxidizer liquids and solids	4	Required	Not permitted
Pyrophoric	Gases	Not required	Required
Unstable (reactive)	4	Required	Not permitted
	3 detonable	Required	Not permitted
	3 nondetonable	Not required	Required
Water-reactive liquids and solids	3	Not required	Required
	2 ^e	Not required	Required
Special Uses			
Acetylene generator rooms	—	Not required	Required
Grain processing	—	Not required	Required
Liquefied petroleum gas distribution facilities	—	Not required	Required
Where explosion hazards exist ^d	Detonation	Required	Not permitted
	Deflagration	Not required	Required

- a. ~~Combustible dusts that are generated during manufacturing or processing. See definition of "Combustible dust" where manufactured, generated or used in such a manner that the concentration and conditions create a fire or explosion hazard based on information prepared in accordance with Section 104.7.2. See definition of "Combustible dust" in Chapter 2.~~
- b. Storage or use.
- c. In open use or dispensing.
- d. Rooms containing dispensing and use of hazardous materials where an explosive environment can occur because of the characteristics or nature of the hazardous materials or as a result of the dispensing or use process.
- e. A method of explosion control shall be provided where Class 2 water-reactive materials can form potentially explosive mixtures.
- f. Explosion venting is not required for Group H-5 Fabrication Areas complying with Chapter 27 and the International Building Code.

2018 International Building Code

Revise as follows:

**[F] TABLE 414.5.1
EXPLOSION CONTROL REQUIREMENTS^{a, h}**

MATERIAL	CLASS	EXPLOSION CONTROL METHODS	
		Barricade construction	Explosion (deflagration) venting or explosion (deflagration) prevention systems ^b
HAZARD CATEGORY			
Combustible dusts ^c	—	Not Required	Required
Cryogenic flammables	—	Not Required	Required
Explosives	Division 1.1	Required	Not Required
	Division 1.2	Required	Not Required
	Division 1.3	Not Required	Required
	Division 1.4	Not Required	Required
	Division 1.5	Required	Not Required
	Division 1.6	Required	Not Required
Flammable gas	Gaseous	Not Required	Required
	Liquefied	Not Required	Required
Flammable liquid	IA ^d	Not Required	Required
	IB ^e	Not Required	Required
Organic peroxides	U	Required	Not Permitted
	I	Required	Not Permitted
Oxidizer liquids and solids	4	Required	Not Permitted
Pyrophoric gas	—	Not Required	Required
Unstable (reactive)	4	Required	Not Permitted
	3 Detonable	Required	Not Permitted
	3 Nondetonable	Not Required	Required
Water-reactive liquids and solids	3	Not Required	Required
	2 ^g	Not Required	Required
SPECIAL USES			
Acetylene generator rooms	—	Not Required	Required
Grain processing	—	Not Required	Required
Liquefied petroleum gas-distribution facilities	—	Not Required	Required
Where explosion hazards exist ^f	Detonation	Required	Not Permitted
	Deflagration	Not Required	Required

- a. See Section 414.1.3.
- b. See the International Fire Code.
- c. ~~As generated during manufacturing or processing.~~ Combustible dusts where manufactured, generated or used in such a manner that the concentration and conditions create a fire or explosion hazard based on information prepared in accordance with Section 104.7.2. See definition of "Combustible dust" in Chapter 2.
- d. Storage or use.
- e. In open use or dispensing.
- f. Rooms containing dispensing and use of hazardous materials where an explosive environment can occur because of the characteristics or nature of the hazardous materials or as a result of the dispensing or use process.
- g. A method of explosion control shall be provided where Class 2 water-reactive materials can form potentially explosive mixtures.
- h. Explosion venting is not required for Group H-5 fabrication areas complying with Section 415.11.1 and the International Fire Code.

Reason:

This footnote is intended for areas where combustible dust is generated or manufactured where actual explosion potential could exist, such as H-2 Occupancies. The way it is written, it can be misleading into requiring explosion control for any area (e.g. small woodworking shps in schools etc.) where combustible dust is manufactured or generated.

Cost Impact

The code change proposal will decrease the cost of construction .

There is no cost associated with this since it is clarifying the intent of the code. It will reduce the cost of construction if it is being misapplied.

Internal ID: 1609

F171-18

IFC: 913.1 (IBC: [F] 913.1)

Proponent: Kevin Scott, representing KH Scott & Associates LLC (khscottassoc@gmail.com)

2018 International Fire Code

Revise as follows:

913.1 General. Where provided, fire pumps for fire protection systems, other than automatic sprinkler systems designed in accordance with Section 903.3.1.3, shall be installed in accordance with this section and NFPA 20.

Reason:

Neither IRC Section P2904 nor NFPA 13D require fire pumps or any pumps to comply with NFPA 20. Pumps used in 1- and 2- family dwellings are not required to be listed for fire protection. Since “fire pumps” are not defined, it could be interpreted to follow NFPA 20 for these systems. This change uses the defined term of fire protection systems as it applies to several water based systems which are required to follow NFPA 20, such as NFPA 13, NFPA 13R, NFPA 14, NFPA 750, etc.

Cost Impact

The code change proposal will decrease the cost of construction .

This will result in cost decrease if jurisdictions were requiring listed fire pumps in dwellings.

Internal ID: 2044

F172-18

IFC: 913.1 (IBC:[F] 913.1)

Proponent: Michael O'Brian, representing National Fire Sprinkler Association (fcac@iccsafe.org)

2018 International Fire Code

Revise as follows:

913.1 General. Where provided, fire pumps, for fire protection systems, shall be installed in accordance with this section and NFPA ~~20-20~~.

Exception: Pumps for automatic sprinkler systems installed in accordance with Section 903.3.1.3 or Section P2904 of the International Residential Code.

Reason:

NFPA 13D does not require fire pumps or any pumps to follow NFPA 20. Pumps used in NFPA 13D systems are not required to be listed for fire protection. Since “fire pumps” are not defined, it could be interpreted to follow NFPA 20 for NFPA 13D systems. This change uses the defined term of fire protection systems as it applies to several water based systems which are required to follow NFPA 20, such as NFPA 13, NFPA 13R, NFPA 14, NFPA 750, etc.

Cost Impact

The code change proposal will not increase or decrease the cost of construction .

This is a clarification of the NFPA 13D standard and code.

Internal ID: 73

F173-18

IFC: 913.2.2 (IBC: [F] 913.2.2)

Proponent: Kevin Scott, representing KH Scott & Associates LLC (khscottassoc@gmail.com)

2018 International Fire Code

Revise as follows:

913.2.2 Circuits supplying fire pumps. Cables used for survivability of circuits supplying fire pumps shall be protected using one of the following methods:

Exception: Cables, or portions of cables, located within a fire pump room or generator room which is separated from the remainder of the occupancy with fire-resistance-rated construction.

1. Cables used for survivability of required critical circuits shall be *listed* in accordance with UL 2196 and shall have a *fire-resistance rating* of not less than ~~1-hour~~ 2 hours.
2. Electrical circuit protective systems shall have a fire-resistance rating of not less than ~~1-hour~~ 2 hours. Electrical circuit protective systems shall be installed in accordance with their listing requirements.
3. Construction having a *fire-resistance rating* of not less than ~~1-hour~~ 2 hours.
4. The cable or raceway is encased in a minimum of 2 inches (50 mm) of concrete.

Reason:

Protecting the fire pump power supply is essential, but more critical when the pump is located within the building.

Section 695.6(A)(2)(d) of NFPA 70 requires that the power supply for fire pumps be protected for a minimum of 2 hours when it is routed through the building. The revisions to Items 1, 2 and 3 will correlate this requirement with the National Electrical Code.

The exception is added to clarify that cables located within the fire pump room are not required to be protected, and cables located with the generator room are not required to be protected. The fire-resistance rating is not specified since it could be either 1-hour or 2-hour based on other code sections.

- IBC Section 901.8 requires that the fire pump room be separated by either 1-hour or 2-hour construction depending on whether the building is high-rise or not.
- IFC/IBC Section 903.3.1.1 allows the elimination of sprinklers in the generator room if the generator room is of 2-hour construction and provided with a fire detection system.

Based on the above sections the separation could be 1-hour or 2-hour. It should also be noted that the 2-hour separation for the generator is not required, but rather an option. If the 2-hour separation and detection is not provided, then the room is provided with sprinklers. Additionally, the proposed exception in 913.2.2 would not apply since there is no fire-resistance-rated separation.

Cost Impact

The code change proposal will increase the cost of construction .

This may increase the cost of construction if listed cables are used and now must be 2-hour rated. However, Item 4 allows embedding the cables in concrete which would not require 2-hour listed cables.

Internal ID: 2048

F174-18

IFC: 913.2.2 (IBC: [F] 913.2.2)

Proponent: Michael O'Brian, Chair, representing FCAC (fcac@iccsafe.org)

2018 International Fire Code

Revise as follows:

913.2.2 Circuits supplying fire pumps. Cables used for survivability of circuits supplying fire pumps shall be protected using one of the following methods:

1. Cables used for survivability of required critical circuits shall be *listed* in accordance with UL 2196 and shall have a *fire-resistance rating* of not less than 1 hour.
2. Electrical circuit protective systems shall have a fire-resistance rating of not less than 1 hour. Electrical circuit protective systems shall be installed in accordance with their listing requirements.
3. Construction having a *fire-resistance rating* of not less than 1 hour.
4. The cable or raceway is encased in a minimum of 2 inches (50 mm) of concrete.

Exception: This section shall not apply to cables, or portions of cables, located within a fire pump room or generator room which is separated from the remainder of the occupancy with fire-resistance-rated construction.

Reason:

Protecting the fire pump power supply is essential, but more critical when the pump is located within the building.

Section 695.6(A)(2)(d) of NFPA 70, the National Electrical Code, requires that the power supply for fire pumps be protected for a minimum of 2 hours when it is routed through the building. These revisions will correlate this requirement with the National Electrical Code.

The exception is added to clarify that where the cables are located within the fire pump room are not required to be protected, and cables located with the generator room are not required to be protected. The fire-resistance rating is not specified since it could be either 1-hour or 2-hour based on other code sections.

IBC Section 901.8 requires that the fire pump room be separated by either 1-hour or 2-hour construction depending on whether the building is high-rise or not.

IFC/IBC Section 903.3.1.1 allows the elimination of sprinklers in the generator room if the generator room is of 2-hour construction and provided with a fire detection system.

Based on the above sections the separation could be 1-hour or 2-hour. It should also be noted that the 2-hour separation for the generator is not required, but rather an option. If the 2-hour separation and detection is not provided, then the room is provided with sprinklers. Additionally, the proposed exception in 913.2.2 would not apply since there is no fire-resistance-rated separation.

This proposal is submitted by the ICC Fire Code Action Committee (FCAC). The FCAC was established by the ICC Board of Directors to pursue opportunities to improve and enhance assigned International Codes with regard to fire safety and hazardous materials in new and existing buildings and facilities and the protection of life and property in wildland urban interface areas. In 2017 the Fire-CAC has held 3 open meetings. In addition, there were numerous conference calls, Regional Work Group and Task Group meetings for the current code development cycle, which included members of the committees as well as any interested parties, to discuss and debate the proposed changes. Related documentation and reports are posted on the FCAC website at: <https://www.iccsafe.org/codes-tech-support/cs/fire-code-action-committee-fcac/>

Cost Impact

The code change proposal will not increase or decrease the cost of construction .

Correlates with the NEC so is simply a clarification.

Internal ID: 278

F175-18

IFC: 914.3.2; IBC: 403.3.3

Proponent: Jeffrey Hugo, representing National Fire Sprinkler Association (hugo@nfsa.org)

2018 International Fire Code

Revise as follows:

914.3.2 Secondary water supply. An automatic secondary on-site water supply having a capacity not less than the hydraulically calculated sprinkler demand, including the hose stream requirement, shall be provided for high-rise buildings assigned to Seismic Design Category C, D, E or F as determined by the International Building Code. An additional fire pump shall not be required for the secondary water supply unless needed to provide the minimum design intake pressure at the suction side of the fire pump supplying the *automatic sprinkler system*. The secondary water supply shall have a duration of not less than 30 minutes as determined by the occupancy hazard classification in accordance with NFPA 13.

Exception: Existing buildings.



2018 International Building Code

Revise as follows:

[F] 403.3.3 Secondary water supply. An automatic secondary on-site water supply having a capacity not less than the hydraulically calculated sprinkler demand, including the hose stream requirement, shall be provided for *high-rise buildings* assigned to Seismic Design Category C, D, E or F as determined by Section 1613. An additional fire pump shall not be required for the secondary water supply unless needed to provide the minimum design intake pressure at the suction side of the fire pump supplying the *automatic sprinkler system*. The secondary water supply shall have a duration of not less than 30 minutes as determined by the occupancy hazard classification in accordance with NFPA 13.

Reason:

Code change F139-13 was approved as modified by public comment (AMPC). It's original intent was to relocate Section 903.3.5.2 of the IBC to the High-rise building provisions of Chapter 4. However, the full text of the 2012 Section 903.3.5.2 was not included. The final phrase of the requirement as well as the exception were not shown in the proposal (nor in the public comment.) The public comment established parallel text in the IFC. That 'parallel' text is as follows:

IFC 914.3.2 Secondary water supply. An automatic secondary on-site water supply having a capacity not less than the hydraulically calculated sprinkler demand, including the hose stream requirement, shall be provided for high-rise buildings assigned to Seismic Design Category C, D, E or F as determined by the International Building Code. An additional fire pump shall not be required for the secondary water supply unless needed to provide the minimum design intake pressure at the suction side of the fire pump supplying the automatic sprinkler system. The secondary water supply shall have a duration of not less than 30 minutes as determined by the occupancy hazard classification in accordance with NFPA 13.

Exception: Existing buildings.

As you can see, the parallel text isn't the same as the IFC contains the additional phrase and exception. To have the sections in agreement, the proposed changes are appropriate. The FCAC may wish to note that the 2015 code also saw the elimination of the Existing buildings chapter (Ch 34) from the IBC. This was in part to concentrate existing building provisions in the IEBC. Since both Section 403 and Chapter 9 deal with new construction the existing building exception is not necessary.

Cost Impact

The code change proposal will not increase or decrease the cost of construction .

The intent of these provisions remain the same and Section 914.3.2 should be duplicate to Section 403.3.3. The exception for existing buildings is unnecessary as these chapters pertain to new construction.

Internal ID: 281

F176-18

IFC: 914.3.8 (New), 914.3.8.1 (New)

Proponent: Stephen DiGiovanni, representing self (sdigiovanni@clarkcountynv.gov)

2018 International Fire Code

Add new text as follows:

914.3.8 Smoke removal. To facilitate smoke removal in post-fire salvage and overhaul operations, buildings and structures shall be equipped with natural or mechanical ventilation for removal of products or combustion in accordance with one of the following:

1. Easily identifiable, manually operable windows or panels shall be distributed around the perimeter of each floor at not more than 50-foot (15 240 mm) intervals. The area of operable windows or panels shall be not less than 40 square feet (3.7 m²) per 50 linear feet (15 240 mm) of perimeter.

Exceptions:

1. In Group R-1 occupancies, each sleeping unit or suite having an exterior wall shall be permitted to be provided with 2 square feet (0.19 m²) of venting area in lieu of the area specified in Item 1.
2. Windows shall be permitted to be fixed provided that glazing can be cleared by fire fighters.
2. Mechanical air-handling equipment providing one exhaust air change every 15 minutes for the area involved. Return and exhaust air shall be moved directly to the outside without recirculation to other portions of the building.
3. Any other approved design that will produce equivalent results.

914.3.8.1 Maintenance. Smoke removal systems shall be maintained in accordance with the manufacturer's instructions to ensure continued system performance. A written schedule for routine maintenance and testing shall be established, and records of such maintenance and testing shall be kept. Operational testing of the smoke removal system shall include all equipment such as initiating means, fans, dampers, controls, doors and windows.

Exception: Fixed windows shall not require operational testing where such windows are routinely maintained and visually inspected.

Reason:

Smoke removal is a requirement for high-rise buildings set forth in Section 403.4.7 of the International Building Code (IBC). While many features of high-rise buildings from the IBC are referenced in Section 914.3 of the International Fire Code (IFC), the smoke removal system is not included in this section. Due to the nature of the system as an aid to fire fighters, it would be appropriate to add the requirement for this system to the IFC as well. This proposal seeks to copy the smoke removal provisions from the IBC, and add them to Section 914 of the IFC.

In addition to adding this section, an additional section regarding maintenance is proposed. As the IFC is often seen as a maintenance code, it is appropriate to add maintenance provisions into the IFC when including the smoke removal system requirements. The proposal is to add the maintenance requirements only to the IFC, and to leave the smoke removal provisions in the IBC untouched. There is precedent for having maintenance requirements appear only in the Fire Code; specifically related to smoke control systems, Section 909.20 of the IFC addresses maintenance of smoke control systems, and maintenance requirements are not included in the IBC (IBC Section 909.20 is smokeproof enclosures).

The language for maintenance that is proposed for smoke removal, is borrowed heavily from the existing maintenance requirements of IFC Section 909.20. As the smoke removal system utilizes similar equipment as is utilized by smoke control systems, Section 909.20 is a natural starting point for creating a maintenance section for smoke removal systems. While the proposal for maintenance of smoke removal systems is not as encompassing as those maintenance provisions that exist for smoke control systems, they are viewed as appropriate as the smoke removal system would typically be less complicated than a smoke control system.

Cost Impact

The code change proposal will increase the cost of construction .

While the cost of construction is not impacted, as the proposal simply copies existing construction requirements from the IBC into the IFC, the cost of operations for the user is increased, if no maintenance or testing of the smoke removal

system was undertaken previously.

Analysis: This proposal is partially trying to repeat language from Section 403.4.7 in the IFC section 914 as new section 914.3.8 that contains duplicate language related to fire protection systems from Chapter 4 of the IFC. Section 914.3.8.1 is new.

Internal ID: 1073

F177-18

IFC: 915.7 (New) (IBC: [F] 915.7 (New))

Proponent: Richard Soltis, Lawrence Township, N.J., representing Self (rsoltis@lawrencetwp.com)

2018 International Fire Code

Add new text as follows:

915.7 Mechanical system connection. Where there is a carbon monoxide detection system, connection to the mechanical system shall be provided for shutdown upon activation of a carbon monoxide detector.

Reason:

When there is a Carbon Monoxide event, along with notifying the occupants, the air distribution system should be shut down to avoid the spread of the hazard. Whether it is caused by the air handling unit itself or another fuel burning appliance within the structure. N.F.P.A. 720 recommends consideration of having carbon monoxide detection perform shutdown of HVAC systems to avoid the spread of carbon monoxide through the structure.

Bibliography:

N.F.P.A. 720, section 5.8.5.4, 2015ed., Carbon Monoxide Detectors for Control of Carbon Monoxide Spread.

Section 5.8.8.4.1, System designers shall consider the spread of carbon monoxide through an occupancy through the HVAC system.

Section 5.8.5.4.2, Interaction with smoke control systems, if such is provided, shall be considered.

Cost Impact

The code change proposal will increase the cost of construction .

The cost incurred would be due to interfacing the Carbon Monoxide detection system with the air handlers to cause shutdown. Even if the Carbon Monoxide detectors are connected to a fire alarm in the structure, there would be the cost incurred when interfacing with the air handlers for shutdown.

Internal ID: 888

F178-18

IFC: 1031.2

Proponent: Ken Brouillette, Seattle Fire Department, representing Seattle Fire Department
(ken.brouillette@seattle.gov)

2018 International Fire Code

Revise as follows:

1031.2 Reliability. Required *exit accesses, exits* and *exit discharges* shall be continuously maintained free from obstructions or impediments to full instant use in the case of fire or other emergency where the building area served by the *means of egress* is occupied. An ~~exit or~~ *exit passageway or corridor* shall not be used for any purpose that interferes with a *means of egress*.

Reason:

The discussion needs to continue regarding what is acceptable to be placed or stored in the egress system. It is not my intention to prohibit the occasional delivery but to give the fire code official the ability to regulate ongoing obstructions to the egress system that could cause delay in evacuations and make it more difficult for emergency personnel to access areas of a building.

Cost Impact

The code change proposal will not increase or decrease the cost of construction .

The proposal is directed to existing buildings and does not affect construction.

Internal ID: 1376

F179-18

IFC: 1031.2.1.1 (New)

Proponent: Michael O'Brian, Chair, representing FCAC (fcac@iccsafe.org)

2018 International Fire Code

Add new text as follows:

1031.2.1.1 Fire escapes. Security enclosures, fences, or screening for fire escape stairways shall be approved by the fire code official and shall be constructed such that they do not impede egress to the public way. Means shall be provided for access to the fire escape stair by emergency personnel from the exterior of the enclosure.

Reason:

Often as a result of owner concerns regarding unlawful access to private property, the retrofitting of security devices at the termination of a fire escape can sometimes be placed or installed in a manner which then prevents their immediate use by emergency personnel.

Cost Impact

The code change proposal will not increase or decrease the cost of construction .

This specific maintenance provision would clarify the need for such access at the termination of the fire escape, It is not intended to increase the cost of compliance.

Internal ID: 534

F180-18

IFC: 1031.3.1

Proponent: John Williams, Chair, representing Healthcare Committee (AHC@iccsafe.org)

2018 International Fire Code

Revise as follows:

1031.3.1 Group I-2. In Group I-2, the required clear width for *aisles, corridors* and *ramps* that are part of the required *means of egress* shall comply with Section 407.4.3 of the International Building Code and Section 1020.2. ~~The facility shall have a plan to maintain the required clear width during emergency situations.~~

Exception: In areas required for bed movement, equipment shall be permitted in the required width where all of the following provisions are met:

1. The equipment is low hazard and wheeled.
2. The facility shall have a plan to remove wheeled equipment in order to maintain the required clear width during emergency situations.
3. The equipment does not reduce the effective clear width for the *means of egress* to less than 5 feet (1525 mm).
4. The equipment is limited to:
 - 4.1. Equipment and carts in use.
 - 4.2. Medical emergency equipment.
 - 4.3. Infection control carts.
 - 4.4. Patient lift and transportation equipment.
5. Medical emergency equipment and patient lift and transportation equipment, when not in use, are required to be located on one side of the corridor.
6. The equipment is limited in number to not more than one per patient sleeping room or patient care room within each smoke compartment.

Reason:

This clarification of language is required in order to conform with Federal Standards and CMS enforcement rules (K211). The reference to Section 407.4.3 is to point to the fixed furniture requirements for hospitals and nursing homes. This relocated language gives the AHJ enforcement language to ensure that all wheeled equipment that may be occasionally found in hallways, must be included in the facility's emergency plan and must be moved out of the required egress width in the event of an emergency situation. Items that are often found in corridors include crash carts and infection control carts, which are needed to be near the point of use and readily available in typical circumstances, but must be moved out of the corridor during emergencies.

This proposal is submitted by the ICC Committee on Healthcare (CHC). The CHC was established by the ICC Board to evaluate and assess contemporary code issues relating to healthcare facilities. This is a joint effort between ICC and the American Society for Healthcare Engineering (ASHE), a subsidiary of the American Hospital Association, to eliminate duplication and conflicts in healthcare regulation. In 2017 the CHC held 2 open meetings and numerous conference calls, which included members of the committees as well as any interested parties, to discuss and debate the proposed changes. Information on the CHC, including: meeting agendas; minutes; reports; resource documents; presentations; and all other materials developed in conjunction with the CHC effort can be downloaded from the CHC website at: <https://www.iccsafe.org/codes-tech-support/cs/icc-committee-on-healthcare/>.

Cost Impact

The code change proposal will not increase or decrease the cost of construction .

This proposed language is operational clarification.

Internal ID: 580

F181-18

IFC: 1031.7; IPMC: [F]702.4

Proponent: Ed Kullik, Chair, representing ICC Building Code Action Committee (bcac@iccsafe.org); Michael O'Brian, Chair, representing FCAC (fcac@iccsafe.org)

2018 International Fire Code

Revise as follows:

1031.7 Emergency escape and rescue openings. Required *emergency escape and rescue openings* shall be maintained in accordance with the ~~that was~~ code in effect at the time of construction, and both of the following:

1. Required *emergency escape and rescue openings* shall be operational from the inside of the room without the use of keys or tools.
2. Bars, grilles, grates or similar devices are ~~allowed~~ permitted to be placed over *emergency escape and rescue openings* provided that the minimum net clear opening size complies with the code that was in effect at the time of construction and such the unit is equipped with smoke alarms installed in accordance with Section 907.2.11 of the International Building Code. Such devices shall be releasable or removable from the inside without the use of a key, tool or force greater than that which is required for normal operation of the *emergency escape and rescue opening*.

2018 International Property Maintenance Code

Revise as follows:

[F] 702.4 Emergency escape ~~openings and rescue openings.~~ Required emergency escape and rescue openings shall be maintained in accordance with the code in effect at the time of construction, and ~~the following.~~ both of the following:

1. Required emergency escape and rescue openings shall be operational from the inside of the room without the use of keys or tools.
2. Bars, grilles, grates or similar devices are permitted to be placed over emergency escape and rescue openings provided that the minimum net clear opening size complies with the code that was in effect at the time of construction and such the unit is equipped with smoke alarms installed in accordance with Section 907.2.11 of the International Building Code. Such devices shall be releasable or removable from the inside without the use of a key, tool or force greater than that which is required for normal operation of the escape and rescue opening.

Reason:

This is one of a series of 11 proposals to coordinate the Emergency Escape and Rescue Openings (EERO) technical criteria in the I-codes. Please see the proposal for the definition of Emergency Escape and Rescue Openings for additional information. Due to the code development schedule the proposals for IFC and IPMC will be proposed in Group A and the proposals for IEC will be proposed in Group B.

The IPMC should be revised to follow the format in the IFC, with a slight editorial change in language. To address situations where someone added these grills without a permit and for consistency with IEBC, add a requirement for smoke detectors.

There will be a coordinating proposal to the IEBC Section 505.4 and 701.4 as part of Group B.

This proposal is submitted by the ICC Fire Code Action Committee (FCAC). The FCAC was established by the ICC Board of Directors to pursue opportunities to improve and enhance assigned International Codes with regard to fire safety and hazardous materials in new and existing buildings and facilities and the protection of life and property in wildland urban interface areas. In 2017 the Fire-CAC has held 3 open meetings. In addition, there were proposed changes. Related documentation and reports are posted on the FCAC website at: FCAC.

Cost Impact

The code change proposal will not increase or decrease the cost of construction .

This is an existing requirement in the IEBC. To add this to IFC and IPMC is just reminding someone what the requirements are, so there is no change to requirements where someone wants to add grills.

F182-18

IFC: 105.6.47 (New), 202 (New), 1001.3 (New), 1031.11 (New), 1031.11.1 (New), 1031.11.2 (New)

Proponent: Michael O'Brian, representing FCAC (fcac@iccsafe.org)

2018 International Fire Code

Add new text as follows:

105.6.47 Valet trash collection. An operational permit is required to use a valet trash collection service in a Group R-2 Occupancy.

Add new definition as follows:

VALET TRASH COLLECTION A service that collects occupant-generated combustible trash or recyclable materials from dwelling units, where the trash is left outside of dwelling units for scheduled pickup.

Add new text as follows:

1001.3 Permits. Permits shall be required as forth in Section 105.6 for the activities regulated in 1031.11.

1031.11 Combustible trash in means of egress. Combustible trash or recyclable materials shall not be placed in exits, in enclosures for stairways or ramps, in corridors, in elevator lobbies or on egress balconies except as permitted by one of the following:

1. Combustible trash or recyclable materials associated with construction, demolition, remodeling, or alterations in accordance with Section 3311.3.
2. Combustible trash or recyclable materials in corridors or on egress balconies of Group R-2 Occupancies that is awaiting scheduled valet trash collection in accordance with Sections 1031.11.1 and 1031.11.2.

1031.11.1 Valet Trash collection. Trash or recyclable materials awaiting valet trash collection shall only be placed in a corridor or on an egress balcony within 18 hours of scheduled pickup and shall not obstruct the minimum egress width required by Section 1020.2.

Trash or recyclable materials awaiting valet trash collection shall be placed completely inside of one or more containers with a closed lid that complies with Section 1031.11.2. Additional trash or recyclable material placed outside of compliant containers are prohibited in a corridor or egress balcony.

1031.11.2 Valet trash collection containers. Containers used for valet trash collection shall not exceed a capacity of 2.0 cubic feet (15 gallons, 0.06 cubic meters) and shall be provided with tight-fitting or self-closing lids. Containers and lids shall comply with one of the following:

1. Containers and lids located in an area protected by fire sprinklers shall be constructed entirely of noncombustible materials or materials that meet a peak rate of heat release not exceeding 300 kW/m² when tested in accordance with ASTM E 1354 at an incident heat flux of 50 kW/m² in the horizontal orientation. Containers and lids shall be listed or bear the label of an approved agency that validates compliance with this requirement. The automatic sprinkler system supplying the sprinklers shall be permitted to comply with Section 903.3.1.1 or 903.3.1.2.
2. Containers and lids located in an area that is not protected by fire sprinklers in accordance with Item 1 shall be constructed entirely of noncombustible materials or materials that meet a peak rate of heat release not exceeding 150 kW/m² when tested in accordance with ASTM E 1354 at an incident heat flux of 50 kW/m² in the horizontal orientation. Containers and lids shall be listed or bear the label of an approved agency that validates compliance with this requirement. Wall and ceiling finishes in the area where valet trash collection containers are placed for pickup shall be noncombustible or shall comply with the requirements of Section 803 for Class B interior finish materials.

Reason:

Valet trash collection services have become common in many R-2 occupancies. Occupants receiving this service place trash and recyclables in the corridors outside of their apartments to be picked up by a collection service, which

typically comes by on a regular scheduled basis.

Currently, there are no provisions in the IFC that specifically prohibit or regulate the placement of combustible trash or recyclables in common egress areas for pickup by others. Without regulation, the hazard of excessive fire loading or exit obstruction is significant. This proposal seeks to establish reasonable safety precautions to allow this process to be offered, based on:1. An operational permit is required, ensuring that the Fire Code Official is aware that the service is being provided and encouraging code compliance.2. Requires that trash containers not obstruct the minimum required clear width of the means of egress.3. Clarifies that, in general, trash is not allowed to be accumulated in exits, corridors or egress balconies.4. Regulates trash containers and interior finish of the container placement area based on whether fire sprinklers are provided.

This proposal is submitted by the ICC Fire Code Action Committee (FCAC). The FCAC was established by the ICC Board of Directors to pursue opportunities to improve and enhance assigned International Codes with regard to fire safety and hazardous materials in new and existing buildings and facilities and the protection of life and property in wildland urban interface areas. In 2017 the Fire-CAC has held 3 open meetings. In addition, there were numerous conference calls, Regional Work Group and Task Group meetings for the current code development cycle, which included members of the committees as well as any interested parties, to discuss and debate the proposed changes. Related documentation and reports are posted on the FCAC website at: FCAC

Cost Impact

The code change proposal will not increase or decrease the cost of construction .

This proposal does not affect construction costs but may increase cost of compliance with the fire code depending upon how the provisions are enforced. However enforcement of these provisions will reduce the risk of fires.

Internal ID: 681

F183-18

IFC: 1103.5, , 1103.5.3, 1105.9.1 (New), TABLE 1103.1

Proponent: Kevin Scott, representing KH Scott & Associates LLC (khscottassoc@gmail.com)

2018 International Fire Code

Revise as follows:

1103.5 Sprinkler systems. *An automatic sprinkler system shall be provided in existing buildings in accordance with Sections 1103.5.1 through ~~1103.5.4~~1103.5.3.*

Delete without substitution:

~~**1103.5.3 Group I-2, Condition 2.** In addition to the requirements of Section 1103.5.2, existing buildings of Group I-2, Condition 2 occupancy shall be equipped throughout with an *approved automatic sprinkler system* in accordance with Section 903.3.1.1. The *automatic sprinkler system* shall be installed as established by the adopting ordinance. [DATE BY WHICH SPRINKLER SYSTEM MUST BE INSTALLED].~~

Revise as follows:

~~1103.5.4~~**1103.5.3 Pyroxylin plastics.** *An automatic sprinkler system shall be provided throughout existing buildings where cellulose nitrate film or pyroxylin plastics are manufactured, stored or handled in quantities exceeding 100 pounds (45 kg). Vaults located within buildings for the storage of raw pyroxylin shall be protected with an *approved automatic sprinkler system* capable of discharging 1.66 gallons per minute per square foot (68 L/min/m²) over the area of the vault.*

Add new text as follows:

1105.9.1 Group I-2, Condition 2 automatic sprinkler system. *An automatic sprinkler system in accordance with Section 903.3.1.1 shall be installed in existing buildings containing a Group I-2, Condition 2 occupancy.*

Revise as follows:

**TABLE 1103.1
OCCUPANCY AND USE REQUIREMENTS^a**

SECTION	USE				OCCUPANCY CLASSIFICATION																		
	High-rise	Atrium or covered mall	Under-ground building	Tire storage	A	B	E	F	H-1	H-2	H-3	H-4	H-5	I-1	I-2	I-3	I-4	M	R-1	R-2	R-3	R-4	S
1103.2	R	R	R	—	R	R	R	R	R	R	R	R	R	R	R	R	R	R	R	R	—	—	R
1103.3	R	—	R	—	R	R	R	R	R	R	R	R	R	R	R	R	R	R	R	R	—	—	R
1103.4.1	R	—	R	—	—	—	—	—	—	—	—	—	—	R	R	—	—	—	—	—	—	—	
1103.4.2	R	—	R	—	R	R	R	R	R	R	R	R	R	R	—	—	R	R	R	R	—	—	R
1103.4.3	R	—	R	—	R	R	R	R	R	R	R	R	R	R	—	—	R	R	R	R	—	—	R
1103.4.4	—	R	—	—	—	—	—	—	—	—	—	—	—	—	—	—	—	—	—	—	—	—	—
1103.4.5	—	—	—	—	—	R	—	—	—	—	—	—	—	—	—	—	—	R	—	—	—	—	—
1103.4.6	—	—	—	—	R	—	R	R	R	R	R	R	R	R	R	R	R	—	R	R	R	R	R
1103.4.7	—	—	—	—	R	—	R	R	R	R	R	R	R	R	R	R	R	—	R	R	R	R	R
1103.4.8	R	—	R	—	R	R	R	R	R	R	R	R	R	R	—	—	R	R	R	R	R	R	R
1103.4.9	R	—	—	—	—	—	—	—	—	—	—	—	—	R	—	—	—	—	—	—	—	—	—
1103.4.10	—	—	—	—	R	R	R	R	R	R	R	R	R	R	R	R	R	R	R	R	R	R	R
1103.5.1	—	—	—	—	R ^e _b	—	—	—	—	—	—	—	—	—	—	—	—	—	—	—	—	—	—
1103.5.2	—	—	—	—	—	—	—	—	—	—	—	—	—	—	R	—	—	—	—	—	—	—	—
1103.5.3	—	—	—	—	—	—	—	—	—	—	—	—	—	—	R ^b	—	—	—	—	—	—	—	—
1103.5.4	—	—	—	—	R	R	R	R	R	R	R	R	R	R	R	R	R	R	R	R	R	R	R
1103.6.1	R	—	R	—	R	R	R	R	R	R	R	R	R	R	R	R	R	R	R	R	—	—	R
1103.6.2	R	—	R	—	R	R	R	R	R	R	R	R	R	R	R	R	R	R	R	R	—	—	R
1103.7.1	—	—	—	—	—	—	R	—	—	—	—	—	—	—	—	—	—	—	—	—	—	—	—
1103.7.2	—	—	—	—	—	—	—	—	—	—	—	—	—	R	—	—	—	—	—	—	—	—	—
1103.7.3	—	—	—	—	—	—	—	—	—	—	—	—	—	—	R	—	—	—	—	—	—	—	—
1103.7.4	—	—	—	—	—	—	—	—	—	—	—	—	—	—	—	R	—	—	—	—	—	—	—
1103.7.5	—	—	—	—	—	—	—	—	—	—	—	—	—	—	—	—	—	—	R	—	—	—	—
1103.7.6	—	—	—	—	—	—	—	—	—	—	—	—	—	—	—	—	—	—	—	R	—	—	—
1103.7.7	—	—	—	—	—	—	—	—	—	—	—	—	—	—	—	—	—	—	—	—	—	R	—
1103.8	—	—	—	—	—	—	—	—	—	—	—	—	—	R	—	—	—	—	R	R	R	R	—
1103.9	R	—	—	—	—	—	—	—	—	—	—	—	—	R	R	—	R	—	R	R	R	R	—
1103.10	—	—	—	—	—	—	—	—	—	—	—	—	—	R	R	—	—	—	—	—	—	—	—
1104	R	R	R	—	R	R	R	R	R	R	R	R	R	R	R	R	R	R	R	R	R	R	R
1105	—	—	—	—	—	—	—	—	—	—	—	—	—	—	R	—	—	—	—	—	—	—	—
1106	—	—	—	R	—	—	—	—	—	—	—	—	—	—	—	—	—	—	—	—	—	—	—

R = The building is required to comply.

- a. Existing buildings shall comply with the sections identified as "Required" (R) based on occupancy classification or use, or both, whichever is applicable.
- ~~b. Only applies to Group I-2, Condition 2 occupancies as established by the adopting ordinance or legislation of the jurisdiction.~~
- ~~e. b.~~ Only applies to Group A-2 occupancies where alcoholic beverages are consumed.

Reason:

This proposal relocates the requirement for sprinklers in existing Group I-2, Condition 2 occupancies to Section 1105.9. Section 1105 deals specifically with Group I-2 occupancies so the code user will most likely be using that section for requirements.

Additionally, Section 1103.5.2 already references Section 1105.9 for all Group I-2 occupancies. So rather than this requirement being lost and hard to find it is proposed to locate it with the other sprinkler requirements for Group I-2 in Section 1105.9.

The statement to comply with the adopting is removed from this requirement. This statement was redundant to Section 1101.4 so it is unnecessary and creates an additional step in the adopting ordinance process. Section 1104 already stipulates time frames and is applicable to all sections in Chapter 11. All the requirements in Chapter 11 are retroactive and applicable to existing buildings. As such, all Chapter 11 requirements also fall under the requirements of Section 1101.4, which states that a time frame for construction documents and completion of the project. The application of Section 1101.4 allows for judgement on the part of the fire code official as to the appropriate time frame for specific projects. Some retrofit projects can be accomplished in a month or two, while others won't even be able to obtain approved construction drawings and a permit in that length of time.

There is no reason for this section to be any different and there are circumstances where completion by a predetermined date may not be appropriate. A review of Table 1103.1 which identifies which sections in Chapter 11 apply to Group I-2 occupancies, identifies that there are many potential retroactive requirements which apply to a Group I-2. It is more appropriate to evaluate the building, establish a complete list of retroactive requirements, then determine the date for completion.

Table 1103.1 is revised to show the deletion of Section 1103.5.3.

Cost Impact

The code change proposal will not increase or decrease the cost of construction .

There is no change in requirements, just a relocation of sections.

Internal ID: 2282

F184-18

IFC: 1103.5, 1103.5.1, 1103.5.2, 1103.5.3, 1103.5.4 (New), 1103.5.5

Proponent: Jeffrey Shapiro, representing National Fire Sprinkler Association (jeff.shapiro@intlcodeconsultants.com); Michael O'Brian, Chair, representing FCAC (fcac@iccsafe.org)

2018 International Fire Code

1103.5 Sprinkler systems. An *automatic sprinkler system* shall be provided in existing buildings in accordance with Sections 1103.5.1 through 1103.5.4.

1103.5.1 Group A-2. Where alcoholic beverages are consumed in a Group A-2 occupancy having an occupant load of 300 or more, the fire area containing the Group A-2 occupancy shall be equipped with an *automatic sprinkler system* in accordance with Section 903.3.1.1.

1103.5.2 Group I-2. In Group I-2, an *automatic sprinkler system* shall be provided in accordance with Section 1105.9.

1103.5.3 Group I-2, Condition 2. In addition to the requirements of Section 1103.5.2, existing buildings of Group I-2, Condition 2 occupancy shall be equipped throughout with an *approved automatic sprinkler system* in accordance with Section 903.3.1.1. The *automatic sprinkler system* shall be installed as established by the adopting ordinance. [DATE BY WHICH SPRINKLER SYSTEM MUST BE INSTALLED].

Add new text as follows:

1103.5.4 High-rise buildings. Where Appendix M has not been adopted, existing high-rise buildings that do not have a previously approved fire sprinkler system shall be equipped with an automatic sprinkler system in accordance with Section 903.3.1.1 when any of the following conditions apply:

1. The high-rise building has an occupied floor located more than 120 feet above the lowest level of fire department vehicle access.
2. The high-rise building has occupied floors located more than 75 feet and not more than 120 feet above the lowest level of fire department vehicle access and the building does not have at least two interior exit stairways complying with Section 1104.10 that are separated from the building interior by fire assemblies having a fire-resistance rating of not less than 2-hours with opening protection in accordance with Table 716.1(2).
3. The high-rise building has occupied floors located more than 75 feet and not more than 120 feet above the lowest level of fire department vehicle access and the building does not have a fire alarm system that includes smoke detection in mechanical equipment, electrical, transformer, telephone equipment and similar rooms; corridors; elevator lobbies; and at doors penetrating interior exit stairway enclosures.

Building owners shall file a compliance schedule with the fire code official not later than 365 days after receipt of a written notice. The compliance schedule shall not exceed 12 years for completion of the automatic sprinkler system retrofit.

Revise as follows:

~~1103.5.4~~1103.5.5 Pyroxylin plastics. An *automatic sprinkler system* shall be provided throughout existing buildings where cellulose nitrate film or pyroxylin plastics are manufactured, stored or handled in quantities exceeding 100 pounds (45 kg). Vaults located within buildings for the storage of raw pyroxylin shall be protected with an *approved automatic sprinkler system* capable of discharging 1.66 gallons per minute per square foot (68 L/min/m²) over the area of the vault.

Reason:

Unsprinklered high-rise buildings represent a significant risk to occupants and emergency responders, and the risk increases as a function of building height and when a building has an insufficient means of egress and inadequate fire detection systems. These risks have been well documented over time in the news media and NFPA reports (<https://www.nfpa.org/News-and-Research/Fire-statistics-and-reports/Fire-statistics/Fires-by-property-type/High-Rise-Building-Fires>), and while catastrophic fires may be infrequent, Grenfell Tower provided another grim reminder of the potential consequences.

The intent of this proposal is to compliment Appendix M, which is an optional appendix that requires all high-rise

buildings to be retrofitted with sprinklers if adopted by a jurisdiction. For jurisdictions not adopting Appendix M, this proposal will provide an less stringent retrofit requirement that offers an incremental step between retrofitting all high-rise buildings with sprinklers versus none at all. High-rise buildings meeting one of three specified conditions would be impacted.

1) Buildings having occupied floors located more than 120 feet above the lowest level of fire department access were selected because these buildings are well beyond the capability of most fire departments to handle with an exterior attack, represent an extreme difficulty with respect to mustering resources on upper floors for interior fire attack, and are difficult to evacuate, particularly when mobility challenged occupants are involved. The 120 foot threshold correlates with IFC Section 907.2.12.3, which requires multiple-channel voice evacuation systems for buildings, and IBC Section 403.6.1, which requires fire service access elevators, in both cases for buildings with an occupied floor more than 120 feet above the lowest level of fire department vehicle access.

2) Any unsprinklered high-rise buildings that does not have at least two exit stairs enclosed by a two-hour fire-rated assembly should be retrofitted with sprinklers. The challenge of occupant evacuation with the counter-flow of emergency responders taking equipment to the fire floor, particularly when mobility challenged occupants must be brought down stairs, is sufficient to justify the need for sprinklers. And, if the stairs are compromised and charged with smoke, occupants cannot be evacuated and firefighter access is further hampered by low visibility and the need to use SCBA while climbing to a fire floor. The 2-hour rating is justified as a minimum requirement because firefighters may need to perform an extended attack in an unsprinklered building, as has been demonstrated in fires such as the First Interstate Bank Fire in Los Angeles.

3) Any unsprinklered high-rise building that does not have a reasonable level of automatic fire detection in common areas to detect a fire, warn occupants and contact emergency responders should be retrofitted with sprinklers. Fires grow at an exponential rate, and delayed detection, alarm and emergency response significantly increases the risk to occupants and emergency responders. It is simply common sense that unsprinklered high-rise buildings should have a reasonable level of automatic fire detection.

The proposal recognizes that some jurisdictions adopting the IFC may have already implemented a high-rise retrofit program in accordance with Appendix M, and where that is the case, this section would not apply. Likewise, some jurisdictions, such as the State of Nevada, implemented high-rise retrofit programs that did not require sprinkler systems to fully comply with NFPA 13. This proposal would not apply to buildings that completed a previously approved retrofit, even if the sprinkler system is not compliant with NFPA 13.

In summary, this proposal should not be read as a suggestion that any high-rise building is sufficiently safe without a fire sprinkler system. However, recognizing that the risk of catastrophic outcomes associated with high-rise fires are a function of building height and other safety features, this proposal advances the idea of incremental progress towards a goal as opposed to no progress at all.

Cost Impact

The code change proposal will not increase or decrease the cost of construction .

This proposal pertains to existing buildings and does not impact the cost of new building construction. There will be an associated cost of retrofitting fire safety equipment in some existing buildings.

Internal ID: 1353

F185-18

IFC: 1103.7.5.1

Proponent: Michael O'Brian, Chair, representing FCAC (fcac@iccsafe.org); Jason Webb, Automatic Fire Alarm Association Codes & Standards Committee, representing Automatic Fire Alarm Association Codes & Standards Committee; Richard Roberts, representing Honeywell (richard.roberts@systemsensor.com)

2018 International Fire Code

Revise as follows:

1103.7.5.1 Group R-1 hotel and motel manual fire alarm system. A manual fire alarm system that activates the occupant notification system in accordance with Section 907.5 shall be installed in existing the following:

1. Existing Group R-1 hotels and motels more than three stories ~~or~~ in height.
2. Existing Group R-1 hotels and motels with more than 20 sleeping units.
3. Existing unsprinklered Group R-1 hotels and motels more than one story in height.

Exceptions:

1. Buildings less than two stories in height where all *sleeping units*, attics and crawl spaces are separated by 1-hour fire-resistance-rated construction and each *sleeping unit* has direct access to a *public way, egress court* or yard.
2. Manual fire alarm boxes are not required throughout the building where the following conditions are met:
 - 2.1. The building is equipped throughout with an *automatic sprinkler system* installed in accordance with Section 903.3.1.1 or 903.3.1.2.
 - 2.2. The notification appliances will activate upon sprinkler water flow.
 - 2.3. Not less than one manual fire alarm box is installed at an *approved* location.

Reason:

For existing unsprinklered Group R-1 occupancies a fire alarm system would be required if the building is more than one story or has more than 20 sleeping units.

Fires in some older multiple story unsprinklered hotels without fire alarm systems, as was allowed in the IBC/IFC up to 2003, have resulted in multiple fire fatalities and fire injuries, where a fire in on the first-floor envelopes the second story means of egress.

Such fires in two-story motels without automatic sprinkler systems occurred on January 4, 2010 in South Birmingham, AL (4 fatalities on the second floor), on December 14, 2013 in Wausau, WI (20 injuries) and in Point Pleasant Beach, NJ on March 21, 2014 (four fatalities on the second floor).

One additional example of a multiple life-loss fire was the Newport, OR City Center Motel on August 5, 2016, 4 civilian fire deaths and 3 civilian fire injuries. Fire deaths occurred on both the ground floor and the 2nd floor. The fire started on the ground floor. No sprinklers and no reports of a fire alarm system sounding.

These fires resulted in fatalities, as second floor occupants could not escape due to the means of egress being blocked by smoke and flames. In these fires resulting in fatalities, no fire alarm system was in place to provide early warning to occupants.

This proposal is submitted by the ICC Fire Code Action Committee (FCAC). The FCAC was established by the ICC Board of Directors to pursue opportunities to improve and enhance assigned International Codes with regard to fire safety and hazardous materials in new and existing buildings and facilities and the protection of life and property in wildland urban interface areas. In 2017 the Fire-CAC has held 3 open meetings. In addition, there were numerous conference calls, Regional Work Group and Task Group meetings for the current code development cycle, which included members of the committees as well as any interested parties, to discuss and debate the proposed changes. Related documentation and reports are posted on the FCAC website at: <https://www.iccsafe.org/codes-tech-support/cs/fire->

Cost Impact

The code change proposal will increase the cost of construction .

This change will impact the cost of construction or operation of a smaller number existing hotels. When you need to add notification (horns and strobes) to these buildings, the cost would be about 350.00 a device installed.

Internal ID: 364

F186-18

IFC: 1103.9

Proponent: Michael O'Brian, Chair, representing FCAC (fcac@iccsafe.org)

2018 International Fire Code

Revise as follows:

1103.9 Carbon monoxide ~~alarms-detection~~. Carbon monoxide ~~alarms-detection~~ shall be installed in existing ~~dwelling units and sleeping units~~ Group I-1, I-2, I-4 and R occupancies and in classrooms in Group E occupancies where those units include any of the conditions identified in Sections 915.1.2 through 915.1.6. The carbon monoxide alarms shall be installed in the locations specified in Section 915.2 and the installation shall be in accordance with Section 915.4.

Exceptions:

1. Carbon monoxide alarms are permitted to be solely battery operated where the code that was in effect at the time of construction did not require carbon monoxide detectors to be provided.
2. Carbon monoxide alarms are permitted to be solely battery operated in dwelling units that are not served from a commercial power source.
3. A carbon monoxide detection system in accordance with Section 915.5 shall be an acceptable alternative to carbon monoxide alarms.

Reason:

This proposal accomplishes two things, first it correlates the occupancies in existing buildings for which carbon monoxide detection is required with the occupancies in new buildings which required carbon monoxide detection. It also changes references from "carbon monoxide alarms" to "carbon monoxide detection". This change in terminology will not preclude carbon monoxide alarms from being provided in applications for which they are listed, but better reflects terminology used in Section 915.

Carbon monoxide poisoning incidents have occurred in the occupancies included in this proposal, and in many cases these incidents have resulted in legislative and regulatory solutions that addressed this problem. The proposed revisions provide a consistent method for providing CO detection, but only in installations where a potential source of CO is present, as described in Section 915.1 through 915.1.6.

This proposal is submitted by the ICC Fire Code Action Committee (FCAC). The FCAC was established by the ICC Board of Directors to pursue opportunities to improve and enhance assigned International Codes with regard to fire safety and hazardous materials in new and existing buildings and facilities and the protection of life and property in wildland urban interface areas. In 2017 the Fire-CAC has held 3 open meetings. In addition, there were numerous conference calls, Regional Work Group and Task Group meetings for the current code development cycle, which included members of the committees as well as any interested parties, to discuss and debate the proposed changes. Related documentation and reports are posted on the FCAC website at: <https://www.iccsafe.org/codes-tech-support/cs/fire-code-action-committee-fcac/>

Cost Impact

The code change proposal will increase the cost of construction .

The proposal will increase the cost of construction. The increased cost will be in instances where the new occupancies covered by this proposal do not have carbon monoxide detection.

Internal ID: 2101

F187-18

IFC: TABLE 1104.18

Proponent: Jeffrey Hugo, National Fire Sprinkler Association, representing National Fire Sprinkler Association (hugo@nfsa.org)

2018 International Fire Code

Revise as follows:

**TABLE 1104.18
COMMON PATH, DEAD-END AND TRAVEL DISTANCE LIMITS (by occupancy)**

OCCUPANCY	COMMON PATH OF EGRESS TRAVEL LIMIT		DEAD-END LIMIT		EGRESS ACCESS TRAVEL DISTANCE LIMIT	
	Unsprinklered (feet)	Sprinklered (feet)	Unsprinklered (feet)	Sprinklered (feet) _i	Unsprinklered (feet)	Sprinklered (feet)
Group A	75	207 _{5i}	20 ^a	20 ^a	200	250 _i
Group B ^h	75 ^g	100 _j	50	50	200	300 _i
Group E	75	75 _i	20	50	200	250 _i
Group F-1, S-1	75 ^g	100 _i	50	50	200 ^c	250 ^{c, h, i}
Group F-2, S-2	75 ^g	100 _i	50	50	300	400 _i
Group H-1	25	25 _l	0	0	75	75 _{l, i}
Group H-2	50	100 _l	0	0	75	100 _{l, i}
Group H-3	50	100 _l	20	20	100	150 _{l, i}
Group H-4	75	75 _l	20	20	150	175 _{l, i}
Group H-5	75	75 _l	20	50	150	200 _i
Group I-1	75	75 _i	20	50	200	j
Group I-2	Notes d, e, f	Notes d, e, f, j	Note e	Note e	150	200 ^{b, i}
Group I-3	100	100 _i	NR	NR	150 ^b	200 ^{b, i}
Group I-4	NR	NR	20	20	200	250 _i
Group M	75	100 _i	50	50	200	250 _{i, i}
Group R-1	75	75 _{l, k}	50	50	200	250 _{l, k}
Group R-2	75	125 _{l, k}	50	50	200	250 _{l, k}
Group R-3	NR	NR	NR	NR	NR	NR
Group R-4	NR	NR	NR	NR	NR	NR
Group U	75 ^g	100 _i	20	50	300	400 _j

NR = No Requirements.

For SI: 1 foot = 304.8 mm, 1 square foot = 0.0929 m².

- a. See Section 1029.9.5 for dead-end aisles in Group A occupancies.
- b. This dimension is for the total travel distance, assuming incremental portions have fully utilized their allowable maximums. For travel distance within the room, and from the room exit access door to the exit, see the appropriate occupancy chapter.
- c. See Section 412.7 of the International Building Code for special requirements on spacing of doors in aircraft hangars.
- d. Separation of exit access doors within a care recipient sleeping room, or any suite that includes care recipient sleeping rooms, shall comply with Section 1105.5.6.
- e. In smoke compartments containing care recipient sleeping rooms and treatment rooms, dead-end corridors shall comply with Section 1105.5.5.
- f. In Group I-2, Condition 2, care recipient sleeping rooms or any suite that includes care recipient sleeping rooms shall comply with Section 1105.6.
- g. Where a tenant space in Group B, S and U occupancies has an occupant load of not more than 30, the length of a common path of egress travel shall not be more than 100 feet.
- h. Where the building, or portion of the building, is limited to one story and the height from the finished floor to the bottom of the ceiling or roof slab or deck is 24 feet or more, the exit access travel distance is increased to 400 feet.
- i. For covered and open malls, the exit access travel distance is increased to 400 feet.
- j. Buildings equipped throughout with an automatic sprinkler system in accordance with Section 903.3.1.1
- k. Buildings equipped throughout with an automatic sprinkler system in accordance with Section 903.3.1.2
- l. Group H occupancies equipped throughout with an automatic sprinkler system in accordance with Section 903.2.5

Reason:

This IFC table has no link to sprinkler system standards or sections. This proposal correlates to the three corresponding tables and the required sprinkler system increases in the IBC. The column for common path of egress travel limit correlates to IBC Table 1006.2.1, dead-end column to IBC 1020.4 and the egress access travel distance column to IBC Table 1017.2. Each table has a sprinklered and nonsprinklered column. Without the new footnotes j., k. or l. the user may attribute an increased distance without the appropriate sprinkler system.

Cost Impact

The code change proposal will not increase or decrease the cost of construction .

Correlates IFC table to the three IBC tables.

Internal ID: 857

F188-18

IFC: 1105.5.4.2.2, 1105.5.4.2.4, 1105.5.4.2.5 (New)

Proponent: John Williams, Chair, representing Healthcare Committee (AHC@iccsafe.org)

2018 International Fire Code

Revise as follows:

1105.5.4.2.2 Corridor doors. Doors in *corridor* walls shall limit the transfer of smoke by complying with the following:

1. Doors shall be constructed of not less than 1³/₄ inch-thick (44 mm) solid bonded-core wood or capable of resisting fire not less than 1/3 hour.
Exception: Corridor doors in buildings equipped throughout with an automatic sprinkler system.
2. Frames for side-hinged swinging doors shall have stops on the sides and top to limit transfer of smoke.
3. Where provided, vision panels in doors shall be a fixed glass window assembly installed to limit the passage of smoke. Existing wired glass panels with steel frames shall be permitted to remain in place.
4. ~~Door undercuts~~ The clearance between the bottom of the door and floor shall not exceed 1 inch (25 mm).
5. Doors shall be positive latching with devices that resist not less than 5 pounds (22.2 N). Roller latches are prohibited.
6. Mail slots or similar openings shall be permitted in accordance with Section 1105.5.4.3.

1105.5.4.2.3 Dutch doors. Where provided, dutch doors shall comply with Section 1105.5.4.2.2. In addition, dutch doors shall be equipped with latching devices on either the top or bottom leaf to allow leaves to latch together. The space between the leaves shall be protected with devices such as astragals to limit the passage of smoke.

1105.5.4.2.4 Self- or automatic-closing doors. Where self- or automatic-closing doors are required, closers shall be maintained in operational condition. Hold open devices on doors shall be capable of manual release.

Add new text as follows:

1105.5.4.2.5 Protective plates. Protective plates installed on corridor doors shall not be limited in size.

Reason:

This change has three components dealing with corridor doors in an existing Group I-2 occupancy (K363). The first proposed change is to Section 1105.5.4.2.2, Item 4 it is specific to remove industry terminology that often has multiple understandings of the term and be more specific as to how the opening clearance is to be measured and removing subjectivity.

Next, is the addition of the last sentence to Section 1105.5.4.2.4. Previously the language didn't address the operation of hold open devices often used on corridor doors. This proposed new sentence accomplishes that and states clearly that hold open devices need to be capable of being released manually and not just release via an electrical or mechanical system operation.

Last, is the addition of new Section 1105.5.4.2.5. This provides direction that protective plates attached to doors to protect the viability of a door are not limited in the size. Previously there was no language to address this common attachment to doors in corridors.

This proposal is submitted by the ICC Committee on Healthcare (CHC). The CHC was established by the ICC Board to evaluate and assess contemporary code issues relating to healthcare facilities. This is a joint effort between ICC and the American Society for Healthcare Engineering (ASHE), a subsidiary of the American Hospital Association, to eliminate duplication and conflicts in healthcare regulation. In 2017 the CHC held 2 open meetings and numerous conference calls, which included members of the committees as well as any interested parties, to discuss and debate the proposed changes. Information on the CHC, including: meeting agendas; minutes; reports; resource documents; presentations; and all other materials developed in conjunction with the CHC effort can be downloaded from the CHC website at: <https://www.iccsafe.org/codes-tech-support/cs/icc-committee-on-healthcare/>.

Cost Impact

The code change proposal will not increase or decrease the cost of construction .

The addition of these provisions are addressing gaps within the existing language to address components often found on or used in conjunction with corridor doors or how to actually measure a maximum clearance.

Internal ID: 603

F189-18

IFC: 1105.6.1 (New)

Proponent: John Williams, Chair, representing Healthcare Committee (AHC@iccsafe.org)

2018 International Fire Code

Add new text as follows:

1105.6.1 Two means of egress. A means of egress shall be provided from each smoke compartment created by smoke barriers without having to return through the smoke compartment from which means of egress originated. Smoke compartments that do not contain an exit shall be provided with direct access to not less than two adjacent smoke compartments.

Reason:

This aligns the requirement for exits within Group I-2 smoke compartments within the fire code with the requirements within the building code allowing this to be applied to existing smoke compartments. Repeating of the language establishes the criteria preferred for existing facilities as an independent requirement from new construction. If the requirement changes in the future for new construction, this requirement would remain for existing buildings.

This proposal is submitted by the ICC Committee on Healthcare (CHC). The CHC was established by the ICC Board to evaluate and assess contemporary code issues relating to healthcare facilities. This is a joint effort between ICC and the American Society for Healthcare Engineering (ASHE), a subsidiary of the American Hospital Association, to eliminate duplication and conflicts in healthcare regulation. In 2017 the CHC held 2 open meetings and numerous conference calls, which included members of the committees as well as any interested parties, to discuss and debate the proposed changes. Information on the CHC, including: meeting agendas; minutes; reports; resource documents; presentations; and all other materials developed in conjunction with the CHC effort can be downloaded from the CHC website at: <https://www.iccsafe.org/codes-tech-support/cs/icc-committee-on-healthcare/>.

Cost Impact

The code change proposal will increase the cost of construction .

This could have significant cost increase for historical/existing facilities that do not have two independent exits from a smoke compartment. Due to the defend in place practice in Group I-2 facilities a second exit becomes necessary to avoid a dead-end situation if horizontal evacuation is used. This additional safety requirement is needed and justifies the cost increase.

Internal ID: 597

F190-18

IFC: 1201.1, 1201.3

Proponent: Charles Foster, self, representing Energy Storage Association (chuck@crfenergy.com)

2018 International Fire Code

Revise as follows:

1201.1 Scope. The provisions of this chapter shall apply to the installation, operation, ~~and maintenance, repair, commissioning and decommissioning~~ of energy systems used for generating or storing energy. It shall not apply to equipment associated with the generation, control, transformation, transmission, or distribution of energy installations that is under the exclusive control of an electric utility or lawfully designated agency.

1201.3 Mixed system installation. Where approved, the aggregate nameplate kWh energy of all energy storage systems in a fire area shall not exceed the maximum quantity specified for any of the energy systems in this chapter. Where required by the *fire code official*, a hazard mitigation analysis shall be provided and approved in accordance with Section 104.7.2 to evaluate any potential adverse interaction between the various energy systems and technologies.

Reason:

This proposal expands the current definition to include other typical activities associated with ESS.

The proposal also clarifies the threshold quantity to be based on nameplate rating.

Cost Impact

The code change proposal will not increase or decrease the cost of construction .

This proposal only adds clarity - does not add or remove requirements, therefore it will neither increase or decrease the cost of construction.

Internal ID: 794

F191-18

IFC: 1201.2

Proponent: Joseph Cain, Solar Energy Industries Association (SEIA), representing Solar Energy Industries Association (JoeCainPE@gmail.com)

2018 International Fire Code

Revise as follows:

1201.2 Electrical wiring and equipment. Electrical wiring and equipment used in connection with energy systems shall be installed and maintained in accordance with Chapter 12, Section 604 and NFPA 70.

Reason:

Section 1201.2 appropriately references NFPA 70 and the electrical provisions specific to energy systems that were relocated to IFC Chapter 12 and expanded during the 2018 development cycle. However, some electrical requirements relevant to electrical equipment, wiring and hazards remain in IFC Section 604. This proposal simply adds a pointer to IFC Section 604, such that the reader will find electrical requirements relevant to energy systems that are not specific to energy systems.

Cost Impact

The code change proposal will not increase or decrease the cost of construction .

This proposal includes addition of a pointer only, and does not change technical requirements.

Internal ID: 2000

F192-18

IFC: 1203.4.1, 1203.5.1

Proponent: John Williams, Chair, representing Healthcare Committee (AHC@iccsafe.org)

2018 International Fire Code

Revise as follows:

1203.4.1 Group I-2 and ambulatory care facilities. In Group I-2 occupancies and ambulatory care facilities, emergency and standby power systems shall be maintained in accordance with NFPA 99.

1203.5.1 Group I-2 and ambulatory care facilities. In Group I-2 occupancies and ambulatory care facilities, emergency and standby power systems shall be inspected and tested under load in accordance with NFPA 99.

Reason:

In addition to meeting the previous codes and standards referenced in this section in order to meet federal conditions of participation health care facilities must comply with the inspection and testing requirements of emergency and standby power systems listed in NFPA 99, Health Care Facilities Code (K918). This change will align the inspection and testing requirements of emergency and standby power systems for ambulatory care facilities.

This proposal is submitted by the ICC Committee on Healthcare (CHC). The CHC was established by the ICC Board to evaluate and assess contemporary code issues relating to healthcare facilities. This is a joint effort between ICC and the American Society for Healthcare Engineering (ASHE), a subsidiary of the American Hospital Association, to eliminate duplication and conflicts in healthcare regulation. In 2017 the CHC held 2 open meetings and numerous conference calls, which included members of the committees as well as any interested parties, to discuss and debate the proposed changes. Information on the CHC, including: meeting agendas; minutes; reports; resource documents; presentations; and all other materials developed in conjunction with the CHC effort can be downloaded from the CHC website at: <https://www.iccsafe.org/codes-tech-support/cs/icc-committee-on-healthcare/>.

Cost Impact

The code change proposal will not increase or decrease the cost of construction .

This change is an operational change regarding inspection and testing and will not increase the cost of construction on the healthcare industry.

Internal ID: 695

F193-18

IFC: 202 (New), TABLE 906.1 (IBC: [F] TABLE 906.1), 1202.1, SECTION 1204 (New), 3106.6.2, 3107.16, SECTION 3307 (New), UL (New), Chapter 80

Proponent: Andrew King, International Association of Fire Chiefs, Fire & Life Safety Section, representing International Association of Fire Chiefs, Fire & Life Safety Section (andyk@franklintn.gov)

2018 International Fire Code

Add new definition as follows:

PORTABLE GENERATOR. A mobile internal combustion engine-driven device that provides electrical power.

Revise as follows:

**TABLE 906.1
ADDITIONAL REQUIRED PORTABLE FIRE EXTINGUISHERS**

SECTION	SUBJECT
303.5	Asphalt kettles
307.5	Open burning
308.1.3	Open flames—torches
309.4	Powered industrial trucks
<u>1204.10</u>	<u>Portable generators</u>
2005.2	Aircraft towing vehicles
2005.3	Aircraft welding apparatus
2005.4	Aircraft fuel-servicing tank vehicles
2005.5	Aircraft hydrant fuel-servicing vehicles
2005.6	Aircraft fuel-dispensing stations
2007.7	Heliports and helistops
2108.4	Dry cleaning plants
2305.5	Motor fuel-dispensing facilities
2310.6.4	Marine motor fuel-dispensing facilities
2311.6	Repair garages
2404.4.1	Spray-finishing operations
2405.4.2	Dip-tank operations
2406.4.2	Powder-coating areas
2804.3	Lumberyards/woodworking facilities
2808.8	Recycling facilities
2809.5	Exterior lumber storage
2903.5	Organic-coating areas
3006.3	Industrial ovens
3104.12	Tents and membrane structures
3206.10	High-piled storage
3315.1	Buildings under construction or demolition
3317.3	Roofing operations
3408.2	Tire rebuilding/storage
3504.2.6	Welding and other hot work
3604.4	Marinas
3703.6	Combustible fibers
5703.2.1	Flammable and combustible liquids, general
5704.3.3.1	Indoor storage of flammable and combustible liquids
5704.3.7.5.2	Liquid storage rooms for flammable and combustible liquids
5705.4.9	Solvent distillation units
5706.2.7	Farms and construction sites—flammable and combustible liquids storage
5706.4.10.1	Bulk plants and terminals for flammable and combustible liquids
5706.5.4.5	Commercial, industrial, governmental or manufacturing

	manufacturing establishments—fuel dispensing
5706.6.4	Tank vehicles for flammable and combustible liquids
5906.5.7	Flammable solids
6108.2	LP-gas

1202.1 Definitions. The following terms are defined in Chapter 2:

BATTERY SYSTEM, STATIONARY STORAGE.

BATTERY TYPES.

Lead-acid battery.

CAPACITOR ARRAY.

CAPACITOR ENERGY STORAGE SYSTEM.

CRITICAL CIRCUIT.

EMERGENCY POWER SYSTEM.

ENERGY MANAGEMENT SYSTEMS.

FUEL CELL POWER SYSTEM, STATIONARY.

PORTABLE GENERATOR.

STANDBY POWER SYSTEM.

STATIONARY BATTERY ARRAY.

Add new text as follows:

SECTION 1204 PORTABLE GENERATORS

1204.1 Portable generators. The use, operation, and maintenance of portable generators shall comply with this section.

1204.2 Carbon monoxide mitigation. Portable generators shall be listed and labeled in accordance with the UL 2201 carbon monoxide mitigation requirements.

1204.3 Operation and maintenance. Portable generators shall be operated and maintained in accordance with the manufacturer's instructions.

1204.4 Grounding. Portable generators shall be grounded in accordance with NFPA 70.

1204.5 Operating locations. Portable generators shall be only operated outdoors a minimum of 10 ft. (1524 m) from any building openings such as windows and doors or air intakes. Portable generators shall not be operated within buildings or enclosed areas. Additional separation shall be provided for tents, membrane structures and outdoor assembly events as specified in Chapter 31 of this Code.

1204.6 Cords and wiring. Extension cords and temporary wiring used to connect portable generators shall be in accordance with Section 604 of this code and shall be provided with GFCI protection.

1204.7 Connections to premise wiring. Connections to a premise wiring system shall comply with all of the following:

1. Power shall not be provided in a manner that "back feeds" receptacles or the premise wiring system.
2. Connection to a premise served by commercial power shall be made through a listed transfer switch installed, used and maintained in accordance with NFPA 70.
3. Connections to buildings not served by commercial power shall comply with NFPA 70.

1204.8 Refueling. Portable generators shall not be refueled while operating.

1204.9 Storage and repair. Storage and repair of fuel fired portable generators shall comply with Section 313.

1204.10 Fire extinguisher. One portable fire extinguisher shall be provided in accordance with Section 906 for an Ordinary (Moderate) hazard Class B and Class C fire hazard, and placed in an approved location.

Revise as follows:

3106.6.2 Generators-Portable generators.. ~~Generators-Portable generators~~ shall comply with Section 1204. Portable generators shall be installed not less than 10 feet (3048 mm) from combustible materials, and shall be isolated from the public by physical guard, fence or enclosure installed not less than 3 feet (914 mm) away from the internal combustion power source.

3107.16 Separation of generators-Portable generator separation.. ~~Generators-Portable generators~~ and other internal combustion power sources shall be separated from tents or membrane structures by not less than 20 feet (6096 mm) and shall be isolated from contact with the public by fencing, enclosure or other *approved* means.

Add new text as follows:

SECTION 3307 PORTABLE GENERATORS

3307.1 General. Portable generators used at construction and demolition sites shall comply with Section 1204.

Add new standard(s) follows:

UL

Underwriters Laboratories LLC
333 Pfingsten Road
Northbrook IL 60062

UL 2201-18:

Standard for Tests for Determining Carbon Monoxide (CO) Emission Rate of Portable Generators

Reason:

The use of portable generators is unregulated in the IFC, except for Section 313 storage, use and repair requirements and some Chapter 31 setback requirements. These products are frequently used to provide power at special outdoor events, construction sites, and during power outages, which often occur during and following natural disasters. A 2016 Consumer Product Safety Commission (CPSC) staff report https://www.cpsc.gov/s3fs-public/PGMAsummitCPSCstaffpresentation_2.pdf?utm_source=rss&utm_medium=rss&utm_campaign=Portable%20Generator%20Technical%20Reports indicated that in the 9 year period of 2004 through 2012, there were 8,703 CO injuries and 666 fatalities associated with the use of portable generators. The report also indicated that a typical engine powering a 5 kW portable generator emits a weighted average CO rate of nominally 1500 g/hr, compared to an idling mid-size late 1990's vintage cars that emit 2.4 - 5.4 g/hr of CO.

ut

This proposal provides basic safety requirements for the use of portable generators, including the following:

1. 1204.2 requires portable generators to be listed and labeled in accordance with UL 2201 carbon monoxide mitigation requirements, which (1) limit the amount of CO produced by a portable generator, and (2) require the portable generator to shutoff in elevated CO environments. These requirements were developed based on an analysis of the CPSC CO incident data, and are complementary, addressing both indoor misuse and outdoor use incidents. In accordance with UL 2201, the CO emission rate shall not exceed 150 g/h, and the generator shall shutoff at any time when there is a peak 400 ppm CO concentration, or the average CO concentration is greater than 150 ppm during a rolling 600 seconds during the test.
2. 1204.5 includes restrictions on locations where portable generators can be operated to minimize the chance of carbon monoxide poisoning and fires.
3. 1204.7 provides guidance on how power from portable generators can be provided to premise wiring systems. Back feeding receptacles is an unsafe practice which can bypass premise overcurrent protection and create a dangerous situation when local commercial power comes back online. It can also endanger utility workers while they repairing power lines, when they are not expecting any power.
4. 1204.10 requires a portable fire extinguisher be provided where portable generators are used. The sizing and rating complies with NFPA 10 for the hazard classification associated with portable generators fueled with a flammable liquid (gasoline). This is consistent with current portable fire extinguisher requirements for mitigation of potential fire hazards.

Cost Impact

The code change proposal will increase the cost of construction .

There could be additional expense for providing portable extinguishers, providing grounding per NFPA 70, providing NFPA 70 compliant connections, and UL 2201 compliant portable generators.

Analysis: A review of the standard proposed for inclusion in the code, UL 2201-18, with regard to the ICC criteria for referenced standards (Section 3.6 of CP#28) will be posted on the ICC website on or before April 2, 2018.

Internal ID: 707

F194-18

IFC: 1204.1, 1204.2.1

Proponent: Joseph Cain, Solar Energy Industries Association (SEIA), representing Solar Energy Industries Association (JoeCainPE@gmail.com)

2018 International Fire Code

Revise as follows:

1204.1 General. Solar photovoltaic (PV) systems shall be installed in accordance with Sections 1204.2 through 1204.5, and the International Building Code or International Residential Code. The electrical portion of solar PV systems shall be installed in accordance with NFPA 70.

1204.2.1 ~~Solar photovoltaic~~ Photovoltaic (PV) panel systems for Group R-3 buildings. ~~Solar photovoltaic Photovoltaic (PV) panel~~ systems for Group R-3 buildings shall comply with Sections 1204.2.1.1 through ~~1204.2.1.3, 1204.2.2,~~

Exceptions:

1. These requirements shall not apply to structures designed and constructed in accordance with the International Residential Code.
2. These requirements shall not apply to roofs with slopes of 2 units vertical in 12 units horizontal or less.

Reason:

The editorial change to Section 1204.1 serves to more-formally introduce the abbreviation "PV" into this section.

The editorial changes to Section 1204.2.1 incorporate the defined term "photovoltaic panel systems," along with the "PV" abbreviation.

The range of applicable sections for Group R-3 is expanded to include up through Section 1204.2.2, Emergency escape and rescue openings.

Cost Impact

The code change proposal will not increase or decrease the cost of construction .

Changes are editorial only, and do not change technical requirements.

Internal ID: 2001

F195-18

IFC: 1204.1, 1204.4, 1204.4.1 (New), 1204.4.2 (New)

Proponent: John Terry, self, representing self (John.Terry@dca.nj.gov)

2018 International Fire Code

Revise as follows:

1204.1 General. ~~Solar-Building-mounted solar~~ photovoltaic systems shall be installed in accordance with Sections 1204.2 through 1204.3 and Section 1204.5, and the International Building Code or International Residential Code. The electrical portion of solar PV systems shall be installed in accordance with NFPA 70. Ground-mounted solar photovoltaic systems shall comply with Section 1204.4.

1204.4 Ground-mounted photovoltaic panel systems. ~~Ground-mounted photovoltaic panel systems shall comply be installed in accordance with Section 1204.1 and this section. Setback requirements shall not apply to ground-mounted, free-standing photovoltaic arrays. A clear, brush-free area of 10 feet (3048 mm) shall be required for ground-mounted photovoltaic arrays. this section and the International Building Code. The electrical portion of solar PV systems shall be installed in accordance with NFPA 70.~~

Add new text as follows:

1204.4.1 Vegetation control. A clear, brush-free area of 10 feet (3048 mm) shall be required around the perimeter of the ground-mounted photovoltaic arrays. A non-combustible base of gravel or a maintained vegetative surface approved by the fire code official shall be installed and maintained under the photovoltaic arrays and associated electrical equipment installations.

1204.4.2 Security. Ground-mounted photovoltaic arrays shall be secured against unauthorized access and safeguarded in an approved manner.

Reason:

When the PV code language was added to the 2012 IFC, Section 604.11.1 dealt with marking of wiring that entered a building and Section 604.11.2 dealt with locations of conductors run within a building. As a result, then Section 604.11.4 for ground mounted systems pointed to these sections for additional requirements. It then had a clear statement that setback requirements, (referred to as access and pathways), did not apply. All of the access and pathway requirements are for the purpose of roof ventilation and access to roof skylights and heat vents.

Going into the 2015 edition of the IFC, the PV requirements were updated including deletion of the wiring requirements because they were relocated to the NEC. As a result the current language in 1204.4 pointing to Section 1204.1 generally does not pick up any additional requirements other than reference to the IBC and NFPA 70.

This has caused a loop for some enforcers and there are code officials now assuming that some portion of access and pathways must apply due to the pointer, such as the 150 by 150 array size limitation which clearly states it is for roof ventilation opportunities.

This proposal eliminates any confusion by breaking the linkage between Sections 1204.1 and 1204.4. The proposal also adds to the vegetation control requirements under the installation and adds security requirements to protect unauthorized persons and animals. As indicated in the appendix of Section 11.12.3.2 of NFPA 1 Fire Code on this topic, though dirt with minor growth is not considered noncombustible, the fire code official might approve dirt bases as long as any growth is maintained under and around the installation to reduce the risk of ignition from the electrical system. An example would be regular mowing to keep the grass or other growth low eliminating an exposure hazard to the installation.

Currently the IBC at Section 1607.13.5.3 requires the area under the structure to be restricted in some manner to keep the public away from the array. Unfortunately, that is buried under the load carrying requirements of the IBC and frequently missed. Adding the language here will coordinate the IFC with the IBC and provide for improved enforcement.

Bibliography:

2015 NFPA 1 Fire Code

11.12.3.2* Noncombustible Base. A gravel base or other noncombustible base acceptable to the AHJ shall be installed and maintained under and around the installation.

A.11.12.3.2 Though dirt with minor growth is not considered noncombustible, the AHJ might approve dirt bases as long as any growth is maintained under and around the installation to reduce the risk of ignition from the electrical system.

This could be a serious consideration for large ground-mounted photovoltaic systems. Not only should the base be considered under the systems, but also around the systems to the point that the risk of fire from growth or other ignition sources will be reduced.

Cost Impact

The code change proposal will not increase or decrease the cost of construction .

This proposal clarifies the intent of existing code requirements, therefore, it has no impact on the cost of construction.

Internal ID: 275

F196-18

IFC: 1203.1.2, Chapter 80; IBC: [F]403.4.8.2, [F] 2702.1.2; Chapter 35

Proponent: Jonathan Roberts, UL LLC, representing UL LLC (jonathan.roberts@ul.com)

2018 International Fire Code

Revise as follows:

1203.1.2 Fuel line piping protection. Fuel lines supplying a generator set inside a high-rise building shall be separated from areas of the building other than the room the generator is located in by ~~an approved method, or an~~ one of the following methods:

1. A fire-resistant pipe-protection system that has been tested in accordance with UL 1489. The system shall be installed as tested and in accordance with the manufacturer's installation instructions, and shall have a rating of not less than 2 hours. Where the building is protected throughout with an automatic sprinkler system installed in accordance with Section 903.3.1.1, the required rating shall be reduced to 1 hour.
2. An assembly that has a fire-resistance rating of not less than 2 hours. Where the building is protected throughout with an automatic sprinkler system installed in accordance with Section 903.3.1.1, the required fire-resistance rating shall be reduced to 1 hour.
3. Other approved methods.

Add new standard(s) follows:

UL

Underwriters Laboratories LLC
333 Pfingsten Road
Northbrook IL 60062

1489-2016:

Fire Resistant Pipe Protection Systems Carrying Combustible Liquids

2018 International Building Code

Revise as follows:

[F] 403.4.8.2 Fuel line piping protection. Fuel lines supplying a generator set inside a building shall be separated from areas of the building other than the room the generator is located in by ~~an approved method or one of the~~ following methods:

1. A fire-resistant pipe-protection system that has been tested in accordance with UL 1489. The system shall be installed as tested and in accordance with the manufacturer's installation instructions, and shall have a rating of not less than 2 hours. Where the building is protected throughout with an automatic sprinkler system installed in accordance with Section 903.3.1.1, the required rating shall be reduced to 1 hour.
2. An assembly that has a fire-resistance rating of not less than 2 hours. Where the building is protected throughout with an automatic sprinkler system installed in accordance with Section 903.3.1.1, the required fire-resistance rating shall be reduced to 1 hour.
3. Other approved methods.

[F] 2702.1.2 Fuel-line piping protection. Fuel lines supplying a generator set inside a *high-rise building* shall be separated from areas of the *building* other than the room the generator is located in by ~~an approved method, or an~~ one of the following methods:

1. A fire-resistant pipe-protection system that has been tested in accordance with UL 1489. The system shall be installed as tested and in accordance with the manufacturer's installation instructions, and shall have a rating of not less than 2 hours. Where the building is protected throughout with an automatic sprinkler system installed in accordance with Section 903.3.1.1, the required rating shall be reduced to 1 hour.
2. An assembly that has a fire-resistance rating of not less than 2 hours. Where the building is

protected throughout with an automatic sprinkler system installed in accordance with Section 903.3.1.1, the required fire-resistance rating shall be reduced to 1 hour.

3. Other approved methods.

Add new standard(s) follows:

UL

UL LLC
333 Pfingsten Road
Northbrook IL 60062-2096

1489-2016:

Fire Resistant Pipe Protection Systems Carrying Combustible Liquids

Reason:

This proposal is intended to provide a third option for protecting fuel lines supplying a generator set inside a high-rise building. The third option is through the use of a fire-resistant pipe-protection system tested to UL 1489, "Fire Resistant Pipe Protection Systems Carrying Combustible Liquids". The system shall be installed as tested and in accordance with the manufacturer's installation instructions.

UL 1489 addresses the fire-resistive performance of fuel lines protected for an hourly rating. UL 1489 compliments the two standards currently referenced in the International Fire Code for establishing fire-resistance ratings: ASTM E119 and UL 263. The standard describes the same test equipment and same time-temperature fire exposure as ASTM E119 and UL 263. However, the sample testing configuration specifically addresses pipe-protection systems. The Conditions of Acceptance follow the intent of ASTM E119 and UL 263, but specifically address the performance requirements for fire-resistant pipe-protection systems. Specifically, the Conditions of Acceptance requires 1) resistance to the fire and hose stream exposure without developing openings in the pipe, and 2) preventing a temperature increase exceeding 325°F at any single point or 250°F at any cross section along the pipe.

Cost Impact

The code change proposal will not increase or decrease the cost of construction .

Fuel lines supplying stationary generators already require protection in accordance with this section. This proposal simply provides an additional option for protecting the fuel lines.

Analysis: A review of the standard proposed for inclusion in the code, UL 1489-2016 Fire Resistant Pipe Protection Systems Carrying Combustible Liquids, with regard to the ICC criteria for referenced standards (Section 3.6 of CP#28) will be posted on the ICC website on or before April 2, 2018.

Internal ID: 226

F197-18

IFC: 1204.2

Proponent: Michael O'Brian, Chair, representing FCAC (fcac@iccsafe.org)

2018 International Fire Code

Revise as follows:

1204.2 Access and pathways. Roof access, pathways, and spacing requirements shall be provided in accordance with Sections 1204.2.1 through 1204.3.3. Pathways shall be over areas capable of supporting fire fighters accessing the roof. Pathways shall be located in areas with minimal obstructions, such as vent pipes, conduit or mechanical equipment.

Exceptions:

1. Detached, nonhabitable Group U structures including, but not limited to, detached garages serving Group R-3 buildings, parking shade structures, carports, solar trellises and similar structures.
2. Roof access, pathways and spacing requirements need not be provided where the *fire code official* has determined that rooftop operations will not be employed.
3. Designated pathways are not required for building integrated photovoltaic (BIPV) systems where the BIPV systems are approved, integrated into the finished roof surface and are listed in accordance with a national test standard developed to address Section 690.12(B)(2) of NFPA 70. The removal or cutting away of portions of the system during specific firefighting operations shall not expose a firefighter to slipping hazards, fall hazards, or electrical shock hazards that are not common to similar traditional roofing systems.

Reason:

The technology of solar roofs has been advancing with new materials and methods, particularly in the area of BIPV. Unlike conventional PV panel systems mounted above the roof surface, BIPV systems are integrated into the finished roof surface, and do not present significant trip hazards or physical obstacles to equipment such as ladders that typically exist with other systems. Portions of these systems, and soon the entire roof system, may be listed to meet the NEC safety thresholds for firefighters upon rapid shutdown activation. There are BIPV systems available today that have been shown through testing to not present electrical hazards to firefighters even when cutting into them during ventilation operations. In order to build confidence in the safety features and performance of these systems an evaluation by a NRTL should be required.

These systems eliminate the hazard to firefighters for large portions of the roof, or in some cases the entire roof where BIPV is installed, eliminating the need to provide for access and pathways.

This proposal is intended to provide recognition of those safety levels by adding exceptions to the access and pathways portion of the IFC PV requirements.

This proposal is submitted by the ICC Fire Code Action Committee (FCAC). The FCAC was established by the ICC Board of Directors to pursue opportunities to improve and enhance assigned International Codes with regard to fire safety and hazardous materials in new and existing buildings and facilities and the protection of life and property in wildland urban interface areas. In 2017 the Fire-CAC has held 3 open meetings. In addition, there were numerous conference calls, Regional Work Group and Task Group meetings for the current code development cycle, which included members of the committees as well as any interested parties, to discuss and debate the proposed changes. Related documentation and reports are posted on the FCAC website at: <https://www.iccsafe.org/codes-tech-support/cs/fire-code-action-committee-fcac/>

Cost Impact

The code change proposal will not increase or decrease the cost of construction .

This code change is intended to address an emerging technology that will be optional for a design professional and/or contractor to use. If approved it will simply pave the way for a potentially safer and more aesthetically pleasing solar PV option. Other technologies that are currently existing may still be used and the mass production of this technology should make it a viable option. This code change will not mandate the use of the new technology but will allow additional options.

Internal ID: 1905

F198-18

IFC: 1204.2

Proponent: Jason Fisher, Tesla Inc., representing Tesla Inc.

2018 International Fire Code

Revise as follows:

1204.2 Access and pathways. Roof access, pathways, and spacing requirements shall be provided in accordance with Sections 1204.2.1 through 1204.3.3. Pathways shall be over areas capable of supporting fire fighters accessing the roof. Pathways shall be located in areas with minimal obstructions, such as vent pipes, conduit or mechanical equipment.

Exceptions:

1. Detached, nonhabitable Group U structures including, but not limited to, detached garages serving Group R-3 buildings, parking shade structures, carports, solar trellises and similar structures.
2. Roof access, pathways and spacing requirements need not be provided where the *fire code official* has determined that rooftop operations will not be employed.
3. BIPV systems integrated into the finished roof surface, listed in accordance with Section 690.12(B)(2) of NFPA 70, where the removal or cutting away of portions of the system during specific firefighting operations have been determined to not expose a firefighter to electrical shock hazards.

Reason:

The technology of solar roofs has been advancing with new materials and methods, particularly in the area of BIPV. Unlike conventional PV panel systems mounted above the roof surface, BIPV systems are integrated into the finished roof surface, and do not present significant trip hazards or physical obstacles to equipment such as ladders that typically exist with other systems. These systems can be listed to meet the NEC safety thresholds for firefighters upon rapid shutdown activation. There are BIPV systems available today that have been shown through testing to not present electrical hazards to firefighters even when cutting into them during ventilation operations. In order to build confidence in the safety features and performance of these systems an evaluation by a NRTL should be required.

Since listed and tested systems meeting these exception requirements would reduce shock hazards to firefighters performing rooftop operations, including vertical ventilation activities, and since the PV portion of the roof is integrated into the finished roof surface, thus not presenting a physical barrier to firefighters needing access to these areas, these types of systems should not be required to restrict the locations of the PV portions of the roof around perimeter pathways, since the entire roof would provide firefighter access.

This proposal is intended to provide recognition of these improved safety levels by adding exceptions to the access and pathways portion of the IFC PV requirements.

Cost Impact

The code change proposal will not increase or decrease the cost of construction .

This code change does not mandate the installation of BIPV systems that include these safety features. Existing BIPV systems and other types of PV systems are not impacted by this proposal.

Internal ID: 2014

F199-18

IFC: 1204.2.2

Proponent: Joseph Cain, Solar Energy Industries Association (SEIA), representing Solar Energy Industries Association (JoeCainPE@gmail.com)

2018 International Fire Code

Revise as follows:

1204.2.2 Emergency escape and rescue openings. ~~Panels and modules installed on Group R-3 buildings~~ Photovoltaic (PV) panel systems shall not be placed on the portion of a roof that is below an emergency escape and rescue opening. A pathway of not less than 36 inches (914 mm) wide shall be provided to ~~the~~ not fewer than one emergency escape and rescue ~~opening~~ opening for each sleeping room.

Reason:

Section 1204.2.2 was new in the 2018 IFC, as a result of Proposal F-87 Part 1.

"Panels and modules" is a non-specific reference to solar photovoltaic (PV) systems. This incomplete language does not correlate to terms defined in the IBC. "Photovoltaic panel system" is a term defined in the IBC and IRC.

As written in the 2018 IFC, this provision applies only to Group R-3 occupancies. However, IBC and IFC Section 1030.1 also require emergency escape and rescue openings for Group R-2 and Group R-4 occupancies, in certain cases. By removing the R-3 buildings, the access pathway requirement is expanding to any occupancy where emergency escape and rescue openings are required. In those cases where a sleeping room has more than one opening that meets the dimensional criteria for an emergency escape and rescue opening, an access pathway is required to not fewer than one emergency escape and rescue opening for each sleeping room. The language "not fewer than one" is consistent with language found in IBC/IFC Section 1030.1.

Cost Impact

The code change proposal will not increase or decrease the cost of construction .

This proposal clarifies that access pathways are required to emergency escape and rescue openings in any residential occupancy where they are required by IFC Section 1030 and IBC Section 1030. This will neither increase nor decrease the cost of construction.

Internal ID: 1607

F200-18

IFC: 1204.2.3 (New)

Proponent: Kevin Reinertson, Riverside County Fire Department, representing Riverside County Fire Department
(kevin.reinertson@fire.ca.gov)

2018 International Fire Code

Add new text as follows:

1204.2.3 Building Integrated Photovoltaic (BIPV) systems. Where building integrated photovoltaic (BIPV) systems are installed in a manner that creates areas with electrical hazards to be hidden from view, markings shall be provided to identify the hazardous areas to avoid. The markings shall be reflective and be visible from grade.

Reason:

When Building Integrated Photovoltaic (BIPV) Systems are installed upon roofs, the areas containing electrical hazards can be hidden from view of firefighters and other responders seeking to access the roof for emergency operations. With at least one manufacturer the entire roof surface has the same appearance, photovoltaic and non-photovoltaic tiles have the same finish, preventing any awareness of where the system is located.

The purpose of this proposal to require markings warning firefighters and others that access the roof of where the areas are they must avoid for safety purposes. The marking must be readily visible day and night and visible from grade to avoid ground ladder placement at an area with an electrical hazard.

Cost Impact

The code change proposal will increase the cost of construction .

The increase of construction is specific to BIPV systems and only includes additional marking or labeling.

Internal ID: 2281

F201-18

IFC: 1204.3.3

Proponent: Joseph Cain, Solar Energy Industries Association (SEIA), representing Solar Energy Industries Association (JoeCainPE@gmail.com); Kevin Reinertson, Riverside County Fire Department, representing Riverside County Fire Department (kevin.reinertson@fire.ca.gov)

2018 International Fire Code

1204.3.3 Smoke ventilation. The solar installation shall be designed to meet the following requirements:

1. Where nongravity-operated smoke and heat vents occur, a pathway not less than 4 feet (1219 mm) wide shall be provided bordering all sides.
2. ~~Smoke ventilation options between array sections shall be one of the following:~~
 - ~~2.1. A pathway not less than 8 feet (2438 mm) wide.~~
 - ~~2.2.~~
3. Smoke ventilation options between array sections shall be one of the following:
 - 3.1. A pathway not less than 8 feet (2438 mm) wide.
 - 3.2. A pathway not less than 4 feet (1219 mm) wide bordering 4-foot by 8-foot (1219 mm by 2438 mm) venting cutouts every 20 feet (6096 mm) on alternating sides of the pathway.

Reason:

Section 1204.3.3 is modified to clarify the original intent that fire fighter access is required to all smoke and heat vents, whether they are nongravity-operated or gravity-operated dropout smoke and heat vents. As in the original intent, access is required to all sides of nongravity-operated smoke and heat vents, and on not fewer than one side of gravity-operated dropout smoke and heat vents.

Two options remain for access pathways between array sections.

Cost Impact

The code change proposal will not increase or decrease the cost of construction .

Language is modified to clarify the original intent that access is required to all smoke & heat vents.

Internal ID: 2004

F202-18

IFC: SECTION 1205, 1205.1, 1205.5, 1205.14 (New)

Proponent: Robert Davidson, Davidson Code Concepts, LLC, representing Toyota, USA
(rjd@davidsoncodeconcepts.com)

2018 International Fire Code

SECTION 1205 STATIONARY FUEL CELL POWER SYSTEMS

Revise as follows:

1205.1 General. *Stationary fuel cell power systems* in new and existing occupancies shall comply with this section.

Exception: The temporary use of a fuel cell powered electric vehicle to power a Group R-3 or R-4 building while parked shall comply with Section 1205.14.

1205.5 Residential use. *Stationary fuel cell power systems* shall not be installed in Group R-3 and R-4 buildings, or dwelling units associated with Group R-2 buildings unless they are specifically listed for residential use.

Exception: The temporary use of a fuel cell powered electric vehicle to power a Group R-3 or R-4 building while parked shall comply with Section 1205.14.

Add new text as follows:

1205.14 Group R-3 and R-4 Fuel Cell Vehicle ESS Use. The temporary use of the dwelling unit owner or occupant's fuel cell powered electric vehicle to power a Group R-3 or R-4 dwelling while parked in an attached or detached garage or outside shall comply with the vehicle manufacturer's instructions and NFPA 70.

Reason:

This proposal is intended to provide correlation with proposals updating the energy storage system provisions in Section 1206 and work being done with the initial NFPA 855 Energy Storage Systems Standard.

Both the current draft of NFPA 855 and an updated proposal to Section 1206 will provide exceptions from the ESS language for temporary use of electric vehicles, (a fuel cell powered vehicle is an electric vehicle), to power R-3 or R-4 dwellings. The NFPA 855 language would also include IRC one- and two-family homes and townhouses.

The conditions are that the vehicles belong to an owner or occupant of the unit, not a third party. Third party applications of mobile ESS is proposed to be separately regulated by NFPA 855 and the IFC.

Additionally the use must comply with the vehicle manufacturer's instructions and NFPA 70 to provide for an appropriate level of safety. The vehicle manufacturer's information covers the approved electric connection on the vehicle itself in accordance with federal standards and NFPA 70 covers the necessary requirements for the electrical connections to the dwelling.

Vehicles capable of being used in this manner already have been marketed. It is more than a convenience issue, in times of natural disasters with associated power outages the ability to utilize the energy provided by the owner/occupants personal vehicle could be critical.

Cost Impact

The code change proposal will not increase or decrease the cost of construction .

The added language will not change the cost of construction. Use of personal vehicles in this manner are optional and any necessary electrical equipment would be required regardless of what standby power method was utilized to power a building.

Internal ID: 1585

F203-18

IFC: 202, 105.6.14 (New), 105.7.2, 105.7.3, 105.7.7 (New), TABLE 903.2.11.6 (IBC: [F] TABLE 903.2.11.6), 907.2.22 (IBC [F] 907.2.22), 907.2.23 (IBC [F] , TABLE 911.1, 1201.1, 1202.1, 1203.2.5 (New), 1203.2.6, 1206, Chapter 80; IBC: [F] TABLE 414.5.1

Proponent: Michael O'Brian, Chair, representing FCAC (fcac@iccsafe.org)

2018 International Fire Code

BATTERY TYPES.

Flow battery. A type of storage battery that includes chemical components dissolved in two different liquids. Ion exchange, which provides the flow of electrical current, occurs through the membrane while both liquids circulate in their respective spaces.

Lead-acid battery. A storage battery that is comprised of lead electrodes immersed in sulphuric acid electrolyte.

Lithium-ion battery. A storage battery with lithium ions serving as the charge carriers of the battery. The electrolyte is a polymer mixture of carbonates with an inorganic salt and can be in a liquid or a gelled polymer form. Lithiated metal oxide is typically a cathode and forms of carbon or graphite typically form the anode.

Nickel-cadmium (Ni-Cd) battery. An alkaline storage battery in which the positive active material is nickel oxide, the negative contains cadmium and the electrolyte is potassium hydroxide. ~~Preengineered stationary storage battery system.~~

~~**Nickel metal hydride (Ni-MH)** An energy storage system consisting of batteries, a battery management system, components and modules that are produced in a factory, designed to comprise the system when assembled on the job site.~~

~~**Prepackaged stationary storage battery system.** An energy storage system consisting of batteries, a battery management system, components and modules that is factory assembled and shipped as a complete unit for installation at the job site.~~

~~**Sodium beta storage battery.** A storage battery, also referred to as a Na beta battery or NBB, which uses a solid beta alumina electrolyte membrane that selectively allows sodium ion transport between a positive electrode such as metal halide and a negative sodium electrode.~~

Delete without substitution:

~~**CAPACITOR ARRAY.** An arrangement of individual capacitor modules in close proximity to each other, mounted on storage racks or in cabinets or other enclosures.~~

CAPACITOR ENERGY STORAGE SYSTEM. A stationary, rechargeable energy storage system consisting of capacitors, chargers, controls and associated electrical equipment designed to provide electrical power to a building or facility. The system is typically used to provide standby or emergency power, an uninterruptable power supply, load shedding, load sharing or similar capabilities.

~~**Preengineered capacitor energy storage system.** A capacitor energy storage system consisting of capacitors, an energy management system, components and modules that are produced in a factory, designed to comprise the system when assembled on the job site.~~

~~**Prepackaged capacitor energy storage system.** A capacitor energy storage system consisting of capacitors, an energy management system, components and modules that is factory assembled and then shipped as a complete unit for installation at the job site.~~

ENERGY STORAGE MANAGEMENT SYSTEMS. An electronic system that protects ~~stationary energy storage batteries systems~~ from operating outside their safe operating parameters, and ~~generates an alarm and trouble signal for off normal conditions~~ disconnects electrical power to the ESS or places it in a safe condition if potentially hazardous temperatures or other conditions are detected.

ENERGY STORAGE SYSTEM (ESS).

One or more devices, assembled together, capable of storing energy in order to supply electrical energy at a future time.

Add new text as follows:

ENERGY STORAGE SYSTEM CABINET. A cabinet containing components of the energy storage system that is included

in the UL 9540 listing for the system. Personnel are not able to enter the enclosure, other than reaching in to access components for maintenance purposes.

ENERGY STORAGE SYSTEM COMMISSIONING.

A systematic process that provides documented confirmation that an energy storage system functions according to the intended design criteria and complies with applicable code requirements.

ENERGY STORAGE SYSTEM DECOMMISSIONING.

A systematic process that provides documentation and procedures that allow an energy storage system to be safely de-energized, disassembled, readied for shipment or storage, and removed from the premise in accordance with applicable code requirements.

ENERGY STORAGE SYSTEM, ELECTROCHEMICAL.

An energy storage system that stores energy and produces electricity using chemical reactions. It includes, among others, battery ESS and capacitor ESS.

ENERGY STORAGE SYSTEM, MOBILE.

An energy storage system capable of being moved and utilized for temporary energy storage applications, and not installed as fixed or stationary electrical equipment. The system can include integral wheels for transportation, or be loaded on a trailer and unloaded for charging, storage and deployment.

ENERGY STORAGE SYSTEM, STATIONARY.

An energy storage system installed as fixed or stationary electrical equipment in a permanent location.

ENERGY STORAGE SYSTEM, WALK-IN UNIT.

A pre-fabricated building that contains energy storage systems. It includes doors that provide walk-in access for personnel to maintain, test and service the equipment, and is typically used in outdoor and mobile ESS applications.

Delete without substitution:

~~**STATIONARY BATTERY ARRAY.** An arrangement of individual stationary storage batteries in close proximity to each other, mounted on storage racks or in modules, battery cabinets or other enclosures.~~

Add new text as follows:

105.6.14 Energy storage systems, mobile. An operational permit is required for mobile energy storage systems regulated by Section 1206.

Delete without substitution:

~~**[A] 105.7.2 Battery systems.** A construction permit is required to install stationary storage battery systems regulated by Section 1206.2.~~

~~**[A] 105.7.3 Capacitor energy storage systems.** A construction permit is required to install capacitor energy storage systems regulated by Section 1206.3.~~

Add new text as follows:

105.7.7 Energy storage systems. A construction permit is required to install energy storage systems regulated by Section 1206.

**TABLE 903.2.11.6
ADDITIONAL REQUIRED FIRE SUPPRESSION SYSTEMS**

SECTION	SUBJECT
914.2.1	Covered and open mall buildings
914.3.1	High-rise buildings
914.4.1	Atriums
914.5.1	Underground structures
914.6.1	Stages
914.7.1	Special amusement buildings
914.8.2	Airport traffic control towers
914.8.3, 914.8.6	Aircraft hangars
914.9	Flammable finishes
914.10	Drying rooms
914.11.1	Ambulatory care facilities
1029.6.2.3	Smoke-protected assembly seating
1103.5.1	Existing Group A occupancies
1103.5.2	Pyroxylin plastic storage in existing buildings
1103.5.3	Existing Group I-2 occupancies
1103.5.4	Existing Group I-2, Condition 2 occupancies
1103.5.4	Pyroxylin plastics
<u>Table 1206.7, Table 1206.8, Table 1206.9, Table 1206.10.</u>	<u>Stationary and mobile energy storage systems</u>
2108.2	Dry cleaning plants
2108.3	Dry cleaning machines
2309.3.2.6.2	Hydrogen motor fuel-dispensing area canopies
2404.2	Spray finishing in Group A, E, I or R
2404.4	Spray booths and spray rooms
2405.2	Dip-tank rooms in Group A, I or R
2405.4.1	Dip tanks
2405.9.4	Hardening and tempering tanks
2703.10	HPM facilities
2703.10.1.1	HPM work station exhaust
2703.10.2	HPM gas cabinets and exhausted enclosures
2703.10.3	HPM exit access corridor
2703.10.4	HPM exhaust ducts
2703.10.4.1	HPM noncombustible ducts
2703.10.4.2	HPM combustible ducts
2807.3	Lumber production conveyor enclosures
2808.7	Recycling facility conveyor enclosures
3006.1	Class A and B ovens
3006.2	Class C and D ovens
Table 3206.2	Storage fire protection
3206.4	Storage
3704.5	Storage of more than 1,000 cubic feet of loose combustible fibers
5003.8.4.1	Gas rooms
5003.8.5.3	Exhausted enclosures
5004.5	Indoor storage of hazardous materials
5005.1.8	Indoor dispensing of hazardous materials
5104.4.1	Aerosol product warehouses

5106.3.2	Aerosol display and merchandising areas
5306.2.1	Exterior medical gas storage room
5306.2.2	Interior medical gas storage room
5306.2.3	Medical gas storage cabinet
5606.5.2.1	Storage of smokeless propellant
5606.5.2.3	Storage of small arms primers
5704.3.7.5.1	Flammable and combustible liquid storage rooms
5704.3.8.4	Flammable and combustible liquid storage warehouses
5705.3.7.3	Flammable and combustible liquid Group H-2 or H-3 areas
6004.1.2	Gas cabinets for highly toxic and toxic gas
6004.1.3	Exhausted enclosures for highly toxic and toxic gas
6004.2.2.6	Gas rooms for highly toxic and toxic gas
6004.3.3	Outdoor storage for highly toxic and toxic gas
6504.1.1	Pyroxylin plastic storage cabinets
6504.1.3	Pyroxylin plastic storage vaults
6504.2	Pyroxylin plastic storage and manufacturing

For SI: 1 cubic foot = 0.023 m³.

Revise as follows:

907.2.22 ~~Battery rooms.~~ Energy storage systems. An automatic smoke detection system or radiant-energy detection system shall be installed in rooms, areas containing stationary storage battery and walk-in units containing energy storage systems as required in Section ~~1206.2.1206.~~

Delete without substitution:

~~**907.2.23 Capacitor energy storage systems.** An automatic smoke detection system shall be installed in areas containing capacitor energy storage systems as required by Section 1206.3.~~

**TABLE 911.1
EXPLOSION CONTROL REQUIREMENTS^f**

MATERIAL	CLASS	EXPLOSION CONTROL METHODS	
		Barricade construction	Explosion (deflagration) venting or explosion (deflagration) prevention systems
Hazard Category			
Combustible dusts ^a	-	Not required	Required
Cryogenic fluids	Flammable	Not required	Required
Explosives	Division 1.1	Required	Not required
	Division 1.2	Required	Not required
	Division 1.3	Not required	Required
	Division 1.4	Not required	Required
	Division 1.5	Required	Not required
	Division 1.6	Required	Not required
Flammable gas	Gaseous	Not required	Required
	Liquefied	Not required	Required
Flammable liquids	IA ^b	Not required	Required
	IB ^c	Not required	Required
Organic peroxides	Unclassified detonable	Required	Not permitted
	I	Required	Not permitted
Oxidizer liquids and solids	4	Required	Not permitted
Pyrophoric	Gases	Not required	Required
Unstable (reactive)	4	Required	Not permitted
	3 detonable	Required	Not permitted
	3 nondetonable	Not required	Required
Water-reactive liquids and solids	3	Not required	Required
	2 ^e	Not required	Required
Special Uses			
Acetylene generator rooms	-	Not required	Required
<u>Electrochemical energy storage systems^d</u>		<u>Not Required</u>	<u>Required</u>
Grain processing	-	Not required	Required
Liquefied petroleum gas distribution facilities	-	Not required	Required
Where explosion hazards exist ^d	Detonation	Required	Not permitted
	Deflagration	Not required	Required

- a. Combustible dusts that are generated during manufacturing or processing. See definition of "Combustible dust" in Chapter 2.
- b. Storage or use.
- c. In open use or dispensing.
- d. Rooms containing dispensing and use of hazardous materials where an explosive environment can occur because of the characteristics or nature of the hazardous materials or as a result of the dispensing or use process.
- e. A method of explosion control shall be provided where Class 2 water-reactive materials can form potentially explosive mixtures.
- f. Explosion venting is not required for Group H-5 Fabrication Areas complying with Chapter 27 and the International Building Code.
- g. Where explosion control is required in Section 1206.6.

Revise as follows:

1201.1 Scope. The provisions of this chapter shall apply to the installation, operation ~~and maintenance, maintenance, repair, retrofitting, testing, commissioning and decommissioning~~ of energy systems used for generating or storing energy. It shall not apply to equipment associated with the generation, control, transformation, transmission, or distribution of energy installations that is under the exclusive control of an electric utility or lawfully designated agency.

1202.1 Definitions. The following terms are defined in Chapter 2:

BATTERY SYSTEM, STATIONARY STORAGE.

BATTERY TYPES.

~~Lead-acid battery.~~

CAPACITOR

~~ARRAY.CAPACITOR~~

ENERGY STORAGE SYSTEM.

CRITICAL CIRCUIT.

EMERGENCY POWER SYSTEM.

ENERGY STORAGE MANAGEMENT SYSTEMS.

ENERGY STORAGE SYSTEM.

ENERGY STORAGE SYSTEM CABINET.

ENERGY STORAGE SYSTEM COMMISSIONING.

ENERGY STORAGE SYSTEM DECOMMISSIONING.

ENERGY STORAGE SYSTEM, ELECTROCHEMICAL.

ENERGY STORAGE SYSTEM, MOBILE.

ENERGY STORAGE SYSTEM, WALK-IN UNIT.

FUEL CELL POWER SYSTEM, STATIONARY.

STANDBY POWER SYSTEM.~~STATIONARY BATTERY ARRAY.~~

Add new text as follows:

1203.2.5 Exhaust ventilation. Standby power shall be provided for mechanical exhaust ventilation systems as required in Section 1206.6.1.2.1. The system shall be capable of powering the required load for a duration of not less than two hours.

1203.2.6 Gas detection systems. Emergency power shall be provided for gas detection systems where required by Sections 1203.2.9 and ~~1203.2.16~~-1203.2.16. Standby power shall be provided for gas detection systems where required by ~~Section 916.5~~Sections 916.5 and 1206.6.2.2.4.

SECTION 1206 ELECTRICAL ENERGY STORAGE SYSTEMS (ESS)

1206.1 General. The provisions in this section are applicable to stationary and mobile electrical energy storage

systems (ESS).

1206.1.1 Scope. ESS having capacities exceeding the values shown in Table 1206.1 shall comply with this section.

1206.1.2 Permits. Permits shall be obtained for ESS as follows:

1. Construction permits shall be obtained for stationary ESS installations and for mobile ESS charging and storage installations covered by 1206.10.1. Permits shall be obtained in accordance with Sections 105.7.7.
2. Operational permits shall be obtained for mobile ESS deployment operations covered by Section 1206.10.3. Permits shall be obtained in accordance with Sections 105.6.14.

TABLE 1206.1
ENERGY STORAGE SYSTEM (ESS) THRESHOLD QUANTITIES

TECHNOLOGY	ENERGY CAPACITY^a
Lead acid batteries, all types	70 KWh (252 Megajoules) ^c
Nickel cadmium batteries (Ni-Cd)	70 KWh (252 Megajoules)
Nickel metal hydride (Ni-MH)	70 KWh (252 Megajoules)
Lithium-ion batteries	20 KWh (72 Megajoules)
Flow batteries ^b	20 KWh (72 Megajoules)
Other battery technologies	10 KWh (36 Megajoules)
Capacitor ESS	3 KWh (10.8 Mega joules)
Other electrochemical ESS technologies	3 KWh (10.8 Mega joules)

a. Energy capacity is the total energy capable of being stored (nameplate rating), not the usable energy rating. For units rated in Amp-Hours, KWh shall equal rated voltage times amp-hour rating divided by 1000.

b. Shall include vanadium, zinc-bromine, polysulfide-bromide, and other flowing electrolyte type technologies.

c. 50 gallons of lead acid battery electrolyte shall be considered equivalent to 70 KWh.

1206.1.3 Construction documents. The following information shall be provided with the permit application:

1. Location and layout diagram of the room or area in which the ESS is to be installed.
2. Details on the hourly fire-resistance ratings of assemblies enclosing the ESS.
3. The quantities and types of ESS to be installed.
4. Manufacturer's specifications, ratings and listings of each ESS.
5. Description of energy (battery) management systems and their operation.
6. Location and content of required signage.
7. Details on fire suppression, smoke or fire detection, thermal management, ventilation, exhaust and deflagration venting systems, if provided.
8. Support arrangement associated with the installation, including any required seismic restraint.
9. A commissioning plan complying with 1206.2.1.
10. A decommissioning plan complying with 1206.2.3.

1206.1.4 Hazard mitigation analysis. A failure modes and effects analysis (FMEA) or other approved hazard mitigation analysis shall be provided in accordance with Section 104.7.2 under any of the following conditions:

1. Where ESS technologies not specifically identified in Table 1206.1 are provided.
2. More than one ESS technology is provided in a room or enclosed area where there is a potential for adverse interaction between technologies.
3. Where allowed as a basis for increasing maximum allowable quantities. See Section 1206.5.2.

1206.1.4.1 Fault condition. The hazard mitigation analysis shall evaluate the consequences of the following failure modes. Only single failure modes shall be considered.

1. A thermal runaway condition in a single ESS rack, module or unit.
2. Failure of any battery (energy) management system.
3. Failure of any required ventilation or exhaust system.
4. Voltage surges on the primary electric supply.
5. Short circuits on the load side of the ESS.
6. Failure of the smoke detection, fire detection, fire suppression, or gas detection system.
7. Required spill neutralization not being provided or failure of a required secondary containment system.

1206.1.4.2 Analysis approval. The fire code official is authorized to approve the hazardous mitigation analysis provided the consequences of the hazard mitigation analysis demonstrate:

1. Fires will be contained within unoccupied ESS rooms or areas for the minimum duration of the fire-resistance rated separations identified in Section 1206.7.4.
2. Fires in occupied work centers will be detected in time to allow occupants within the room or area to safely evacuate.
3. Toxic and highly toxic gases released during fires will not reach concentrations in excess of IDLH level in the building or adjacent means of egress routes during the time deemed necessary to evacuate occupants from any affected area.
4. Flammable gases released from ESS during charging, discharging and normal operation will not exceed 25 percent of their lower flammability limit (LFL).
5. Flammable gases released from ESS during fire, overcharging and other abnormal conditions will be controlled through the use of ventilation of the gases preventing accumulation or by deflagration

venting.

1206.1.4.3 Additional protection measures. Construction, equipment and systems that are required for the ESS to comply with the hazardous mitigation analysis, including but not limited to those specifically described in Section 1206 shall be installed, maintained and tested in accordance with nationally recognized standards and specified design parameters.

1206.1.5 Large scale fire test. Where required elsewhere in Section 1206, large scale fire testing shall be conducted on a representative ESS in accordance with UL 9540A. The testing shall be conducted or witnessed and reported by an approved testing laboratory and show that a fire involving one ESS will not propagate to an adjacent ESS, and where installed within buildings, enclosed areas and walk-in units will be contained within the room, enclosed area or walk-in unit for a duration equal to the fire resistance rating of the room separation specified in Section 1206.7.4. The test report shall be provided to the fire code official for review and approval in accordance with Section 104.7.2.

1206.1.6 Fire remediation. Where a fire or other event has damaged the ESS and ignition or re-ignition of the ESS is possible, the system owner, agent, or lessee shall take the following actions, at their expense, to mitigate the hazard or remove damaged equipment from the premises to a safe location.

1206.1.6.1 Fire mitigation personnel. Where, in the opinion of the fire code official, it is essential for public safety that trained personnel be on site to respond to possible ignition or re-ignition of a damaged ESS, the system owner, agent or lessee shall immediately dispatch one or more fire mitigation personnel to the premise, as required and approved, at their expense. These personnel shall remain on duty continuously after the fire department leaves the premise until the damaged energy storage equipment is removed from the premises, or earlier if the fire code official indicates the public safety hazard has been abated.

1206.1.6.2 Duties. On-duty fire mitigation personnel shall have the following responsibilities:

1. Keep diligent watch for fires, obstructions to means of egress and other hazards.
2. Immediately contact the fire department if their assistance is needed to mitigate any hazards or extinguish fires.
3. Take prompt measures for remediation of hazards in accordance with the decommissioning plan in Section 1206.2.3.
4. Take prompt measures to assist in the evacuation of the public from the structures.

1206.2 Commissioning, decommissioning, operation and maintenance. Commissioning, decommissioning, operation and maintenance shall be conducted in accordance with this section.

1206.2.1 Commissioning. Commissioning of newly installed ESS, and existing ESS that have been retrofitted, replaced or previously decommissioned and are returning to service shall be conducted prior to the ESS being placed in service in accordance with a commissioning plan that has been approved prior to initiating commissioning. The commissioning plan shall include the following:

1. A narrative description of the activities that will be accomplished during each phase of commissioning including the personnel intended to accomplish each of the activities.
2. A listing of the specific ESS and associated components, controls and safety related devices to be tested, a description of the tests to be performed and the functions to be tested.
3. Conditions under which all testing will be performed, which are representative of the conditions during normal operation of the system.
4. Documentation of the owner's project requirements and the basis of design necessary to understand the installation and operation of the ESS.
5. Verification that required equipment and systems are installed in accordance with the approved plans and specifications.
6. Integrated testing for all fire and safety systems.
7. Testing for any required thermal management, ventilation or exhaust systems associated with the ESS installation.
8. Preparation and delivery of operation and maintenance documentation.
9. Training of facility operating and maintenance staff.

10. Identification and documentation of the requirements for maintaining system performance to meet the original design intent during the operation phase.
11. Identification and documentation of personnel who are qualified to service, maintain and decommission the ESS, and respond to incidents involving the ESS, including documentation that such service has been contracted for.
12. A decommissioning plan for removing the ESS from service, and from the facility in which it is located. The plan shall include details on providing a safe, orderly shutdown of energy storage and safety systems with notification to the code officials prior to the actual decommissioning of the system. The decommissioning plan shall include contingencies for removing an intact operational ESS from service, and for removing an ESS from service that has been damaged by a fire or other event.

Exception: Commissioning shall not be required for lead acid and nickel cadmium battery systems at facilities under the exclusive control of communications utilities that comply with NFPA 76 and operate at less than 50 VAC and 60 VDC. However a decommissioning plan shall be provided and maintained whenever required by the fire code official.

1206.2.1.1 Initial acceptance testing. During the commissioning process an ESS shall be evaluated for proper operation in accordance with the manufacturer's instructions and the commissioning plan prior to final approval.

1206.2.1.2 Commissioning report. A report describing the results of the system commissioning and including the results of the initial acceptance testing required in Section 1206.2.1.1 shall be provided to code official prior to final inspection and approval and maintained at an approved on-site location.

1206.2.2 Operation and maintenance. An operating and maintenance manual shall be provided to both the ESS owner or their authorized agent and the ESS operator before the ESS is put into operation and shall include the following:

1. Manufacturer's operation manuals and maintenance manuals for the entire ESS or for each component of the system requiring maintenance, that clearly identify the required routine maintenance actions.
2. Name, address and phone number of a service agency that has been contracted to service the ESS and its associated safety systems.
3. Maintenance and calibration information, including wiring diagrams, control drawings, schematics, system programming instructions and control sequence descriptions, for all energy storage control systems.
4. Desired or field-determined control set points that are permanently recorded on control drawings at control devices or, for digital control systems, in system programming instructions.
5. A schedule for inspecting and recalibrating all ESS controls.
6. A service record log form that lists the schedule for all required servicing and maintenance actions and space for logging such actions that are completed over time and retained on site.

The ESS shall be operated and maintained in accordance with the manual and a copy of the manual shall be retained at an approved onsite location.

1206.2.2.1 Ongoing inspection and testing. Systems that monitor and protect the ESS installation shall be inspected and tested in accordance with the manufacturer's instructions and the operating and maintenance manual. Inspection and testing records shall be maintained in the operation and maintenance manual.

1206.2.3 Decommissioning. The code official shall be notified prior to decommissioning of an ESS. Decommissioning shall be performed in accordance with the decommissioning plan that includes the following:

1. A narrative description of the activities to be accomplished for removing the ESS from service, and from the facility in which it is located.
2. A listing of any contingencies for removing an intact operational ESS from service, and for removing an ESS from service that has been damaged by a fire or other event.

1206.3 Equipment. ESS equipment shall be in accordance with Sections 1206.3.1 through 1206.3.9

1206.3.1 Energy storage system listings. ESS shall be listed in accordance with UL 9540.

Exception: Lead-acid and nickel cadmium battery systems installed in facilities under the exclusive control of

communications utilities, and operating at less than 50 VAC and 60 VDC in accordance with NFPA 76 are not required to be listed.

1206.3.2 Equipment listing. Chargers, inverters, energy storage management systems shall be covered as part of the UL 9540 listing or shall be listed separately.

1206.3.3 Utility interactive systems. Inverters shall be listed and labeled in accordance with UL 1741. Only inverters listed and labeled for utility interactive system use and identified as interactive shall be allowed to operate in parallel with the electric utility power system to supply power to common loads.

1206.3.4 Energy storage management system. Where required by the ESS listing an approved energy storage management system shall be provided that monitors and balances cell voltages, currents and temperatures within the manufacturer's specifications. The system shall disconnect electrical connections to the ESS or otherwise place it in a safe condition if potentially hazardous temperatures or other conditions such as short circuits, over voltage or under voltage are detected.

1206.3.5 Enclosures. Enclosures of ESS shall be of noncombustible construction.

1206.3.6 Repairs. Repairs of ESS shall only be done by qualified personnel. Repairs with other than identical parts shall be considered retrofitting and comply with Section 1206.3.7. Repairs shall be documented in the service records log.

1206.3.7 Retrofits. Retrofitting of an existing ESS shall comply with the following:

1. A construction permit shall be obtained in accordance with Section 105.7.7.
2. New batteries, battery modules, capacitors and similar ESS components shall be listed in accordance with UL 1973.
3. Battery management and other monitoring systems shall be connected and installed in accordance with the manufacturer's instructions.
4. The overall installation shall continue to comply with UL 9540 listing requirements, where applicable.
5. Systems that have been retrofitted shall be commissioned in accordance with Section 1206.2.1.
6. Retrofits shall be documented in the service records log.

1206.3.7.1 Retrofitting Lead Acid and Nickel Cadmium. Section 1206.3.7 shall not apply to retrofitting of lead acid and nickel cadmium batteries with other lead acid and nickel cadmium batteries at facilities under the exclusive control of communications utilities that comply with NFPA 76 and operate at less than 50 VAC and 60 VDC.

1206.3.8 Replacements. Replacements of ESS shall be considered new ESS installations and shall comply with the provisions of Section 1206 as applicable to new ESS. The ESS being replaced shall be decommissioned in accordance with Section 1206.2.3.

1206.3.9 Reused and repurposed equipment. Equipment and materials shall only be reused or reinstalled as permitted in Section 104.7.1. Storage batteries previously used in other applications, such as electric vehicle propulsion, shall not be reused in applications regulated by Chapter 12, unless (1) approved by the fire code official and (2) the equipment is refurbished by a battery refurbishing company approved in accordance with UL 1974.

1206.4 General installations requirements. Stationary and mobile ESS shall comply with the requirements of section 1206.4.1 through 1206.4.12.

1206.4.1 Electrical disconnects. Where the ESS disconnecting means is not within sight of the main electrical service disconnecting means, placards or directories shall be installed at the location of the main electrical service disconnecting means indicating the location of stationary storage battery system disconnecting means in accordance with NFPA 70.

Exception: Electrical disconnects for lead acid and nickel cadmium battery systems at facilities under the exclusive control of communications utilities and operating at less than 50 VAC and 60 VDC shall be permitted to have electrical disconnects signage in accordance with NFPA 76.

1206.4.2 Working clearances. Access and working space shall be provided and maintained about all electrical equipment to permit ready and safe operation and maintenance of such equipment in accordance with NFPA 70 and the manufacturer's instructions.

1206.4.3 Fire-resistance rated separations. Rooms and other indoor areas containing ESS shall be separated from other areas of the building in accordance with Section 1206.7.4. ESS shall be permitted to be in the same room with the equipment they support.

1206.4.4 Seismic and structural design. Stationary ESS shall comply with the seismic design requirements in Chapter 16 of the International Building Code, and shall not exceed the floor loading limitation of the building.

1206.4.5 Vehicle impact protection. Where ESS are subject to impact by a motor vehicle, including fork lifts, vehicle impact protection shall be provided in accordance with Section 312.

1206.4.6 Combustible storage. Combustible materials shall not be stored in ESS rooms, areas, or walk-in units. Combustible materials in occupied work centers covered by Section 1206.4.10 shall be stored at least 3 feet (914 mm) from ESS cabinets.

1206.4.7 Toxic and highly toxic gases. ESS that have the potential to release toxic and highly toxic gas during charging, discharging and normal use conditions shall be provided with a hazardous exhaust system in accordance with Section 502.8 of the International Mechanical Code.

1206.4.8 Signage. Approved signs shall be provided on or adjacent to all entry doors for ESS rooms or areas and on enclosures of ESS cabinets and walk-in units located outdoors, on rooftops or in open parking garages. Signs designed to meet both the requirements of this section and NFPA 70 shall be permitted. The signage shall include the following or equivalent.

1. "Energy Storage System", "Battery Storage System", "Capacitor Energy Storage System", or the equivalent.
2. The identification of the electrochemical ESS technology present.
3. "Energized electrical circuits"
4. If water reactive electrochemical ESS are present the signage shall include "APPLY NO WATER"
5. Current contact information, including phone number, for personnel authorized to service the equipment and for fire mitigation personnel required by Section 1206.1.6.1.

Exception: Existing electrochemical ESS shall be permitted to include the signage required at the time they were installed.

1206.4.9 Security of installations. Rooms, areas and walk-in units in which electrochemical ESS are located shall be secured against unauthorized entry and safeguarded in an approved manner. Security barriers, fences, landscaping, and other enclosures shall not inhibit the required air flow to or exhaust from the electrochemical ESS and its components.

1206.4.10 Occupied work centers. Electrochemical ESS located in rooms or areas occupied by personnel not directly involved with maintenance, service and testing of the systems shall comply with the following.

1. Electrochemical ESS located in occupied work centers shall be housed in locked noncombustible cabinets or other enclosures to prevent access by unauthorized personnel.
2. Where electrochemical ESS are contained in cabinets in occupied work centers, the cabinets shall be located within 10 feet (3048 mm) of the equipment that they support.
3. Cabinets shall include signage complying with Section 1206.4.8.

1206.4.11 Open rack installations. Where electrochemical ESS are installed in a separate equipment room and only authorized personnel have access to the room, they shall be permitted to be installed on an open rack for ease of maintenance.

1206.4.12 Walk-in units. Walk-in units shall only be entered for inspection, maintenance and repair of ESS units and ancillary equipment, and shall not be occupied for other purposes.

1206.5 Electrochemical ESS Protection. The protection of electrochemical ESS shall be in accordance with Sections 1206.5.1 through 1206.5.8 where required by Section 1206.7 through 1206.10.

1206.5.1 Size and separation. Electrochemical ESS shall be segregated into groups not exceeding 50 KWh (180 Mega joules). Each group shall be separated a minimum three feet (914 mm) from other groups and from walls in the

storage room or area. The storage arrangements shall comply with Chapter 10.

Exceptions:

1. Lead acid and nickel cadmium battery systems in facilities under the exclusive control of communications utilities and operating at less than 50 VAC and 60 VDC in accordance with NFPA 76.
2. The fire code official is authorized to approve larger capacities or smaller separation distances based on large scale fire testing complying with Section 1206.1.5.

1206.5.2 Maximum allowable quantities. Fire areas within rooms, areas and walk-in units containing electrochemical ESS shall not exceed the maximum allowable quantities in Table 1206.5.

Exceptions:

1. Where approved by the fire code official, rooms, areas and walk-in units containing electrochemical ESS that exceed the amounts in Table 1206.5 shall be permitted based on a hazardous mitigation analysis in accordance with Section 1206.1.4 and large scale fire testing complying with Section 1206.1.5.
2. Lead-acid and nickel cadmium battery systems installed in facilities under the exclusive control of communications utilities, and operating at less than 50 VAC and 60 VDC in accordance with NFPA 76.
3. Dedicated use buildings in compliance with Section 1206.7.1.

1206.5.2.1 Mixed electrochemical energy systems. Where rooms, areas and walk-in units contain different types of electrochemical energy technologies, the total aggregate quantities of the systems shall be determined based on the sum of percentages of each technology type quantity divided by the maximum allowable quantity of each technology type. The sum of the percentages shall not exceed 100 percent of the maximum allowable quantity.

**TABLE 1206.5
MAXIMUM ALLOWABLE QUANTITIES OF ELECTROCHEMICAL ESS**

TECHNOLOGY	MAXIMUM ALLOWABLE QUANTITIES ^a
STORAGE BATTERIES	
Lead acid, all types	Unlimited
Nickel cadmium (Ni-Cd)	Unlimited
Nickel metal hydride (Ni-MH)	Unlimited
Lithium-ion	600 KWh
Flow batteries ^b	600 KWh
Other battery technologies	200 KWh
CAPACITORS	
All types	20 KWh
OTHER ELECTROCHEMICAL ESS	
All types	20 KWh

a. For electrochemical ESS units rated in Amp-Hours, KWh shall equal rated voltage times the Amp-hour rating divided by 1000

b. Shall include vanadium, zinc-bromine, polysulfide-bromide, and other flowing electrolyte type technologies

1206.5.3 Elevation. Electrochemical ESS shall not be located in the following areas:

1. Where the floor is located more than 75 feet (22 860 mm) above the lowest level of fire department vehicle access, or
2. Where the floor is located below the lowest level of exit discharge.

Exceptions:

1. Lead acid and Nickel cadmium battery systems less than 50 VAC and 60 VDC installed in facilities under the exclusive control of communications utilities in accordance with NFPA 76.
2. Where approved, installations shall be permitted in underground vaults complying with NFPA 70, Article 450, Part III.
3. Where approved by the fire code official, installations shall be permitted on higher and lower floors.

1206.5.4 Fire detection. An approved automatic smoke detection system or radiant energy-sensing fire detection system complying with Section 907.2 shall be installed in rooms, indoor areas, and walk-in units containing electrochemical ESS. An approved radiant energy-sensing fire detection system shall be installed to protect open parking garage and rooftop installations. Alarm signals from detection systems shall be transmitted to a central station, proprietary or remote station service in accordance with NFPA 72, or where approved to a constantly attended location.

1206.5.4.1 System status. Where required by the fire code official, visible annunciation shall be provided on cabinet exteriors or in other approved locations to indicate that potentially hazardous conditions associated with the ESS exist.

1206.5.5 Fire suppression systems. Rooms and areas within buildings and walk-in units containing electrochemical ESS shall be protected by an automatic fire suppression system designed and installed in accordance with one of the following:

1. An automatic sprinkler systems designed and installed in accordance with Section 903.3.1.1 with a minimum density of 0.3 gpm/ft.² based on the fire area or 2,500 ft.² design area, whichever is smaller.
2. Where approved, an automatic sprinkler system designed and installed in accordance with Section 903.3.1.1 with a sprinkler hazard classification based on large scale fire testing complying with Section 1206.1.5.
3. The following alternate automatic fire extinguishing systems designed and installed in accordance with Section 904, provided the installation is approved by the fire code official based on large scale fire testing complying with Section 1206.1.5

- NFPA 12, Standard on Carbon Dioxide Extinguishing Systems
- NFPA 15, Standard for Water Spray Fixed Systems for Fire Protection
- NFPA 750, Standard on Water Mist Fire Protection Systems
- NFPA 2001, Standard on Clean Agent Fire Extinguishing Systems
- NFPA 2010, Standard for Fixed Aerosol Fire-Extinguishing Systems

Exception: Fire suppression systems for lead acid and nickel cadmium battery systems at facilities under the exclusive control of communications utilities that operate at less than 50 VAC and 60 VDC shall be provided where required by NFPA 76.

1206.5.5.1 Water reactive systems. Electrochemical ESS that utilize water reactive materials shall be protected by an approved alternative automatic fire-extinguishing system in accordance with Section 904, where the installation is approved by the fire code official based on large scale fire testing complying with Section 1206.1.5.

1206.5.6 Maximum enclosure size. Outdoor walk-in units housing ESS shall not exceed 53 feet by 8 feet by 9.5 feet high. Walk-in units that exceed these dimensions shall be considered indoor installations and comply with the requirements in Section 1206.7.

1206.5.7 Vegetation control. Areas within 10 feet (3 m) on each side of outdoor ESS shall be cleared of combustible vegetation and other combustible growth. Single specimens of trees, shrubbery, or cultivated ground cover such as green grass, ivy, succulents, or similar plants used as ground covers shall be permitted to be exempt provided that they do not form a means of readily transmitting fire.

1206.5.8 Means of egress separation. ESS located outdoors and in open parking garages shall be separated from any means of egress as required by the fire code official to ensure safe egress under fire conditions, but in no case less than 10 feet (3048 mm).

Exception: The fire code official is authorized to approve a reduced separation distance if large scale fire testing complying with Section 1206.1.5 is provided that shows that a fire involving the ESS will not adversely impact occupant egress.

1206.6 Electrochemical ESS technology specific protection. Electrochemical ESS installations shall comply with the requirements of this section in accordance with the applicable requirements of Table 1206.6.

**TABLE 1206.6
ELECTROCHEMICAL ESS TECHNOLOGY SPECIFIC REQUIREMENTS**

<u>COMPLIANCE REQUIRED</u> ^b	<u>BATTERY TECHNOLOGY</u>				<u>OTHER ESS AND BATTERY TECHNOLOGIES</u> ^b	<u>CAPACITOR ESS</u> ^b
	<u>Lead-acid</u>	<u>Ni-Cad and Ni-MH</u>	<u>Lithium-ion</u>	<u>Flow</u>		
<u>1206.6.1 Exhaust ventilation</u>	<u>Yes</u>	<u>Yes</u>	<u>No</u>	<u>Yes</u>	<u>Yes</u>	<u>Yes</u>
<u>1206.6.2 Spill control and neutralization</u>	<u>Yes</u> ^c	<u>Yes</u> ^c	<u>No</u>	<u>Yes</u>	<u>Yes</u>	<u>Yes</u>
<u>1206.6.3Explosion control</u>	<u>Yes</u> ^a	<u>Yes</u> ^a	<u>Yes</u>	<u>No</u>	<u>Yes</u>	<u>Yes</u>
<u>1206.6.4 Safety caps</u>	<u>Yes</u>	<u>Yes</u>	<u>No</u>	<u>No</u>	<u>Yes</u>	<u>Yes</u>
<u>1206.6.5 Thermal runaway</u>	<u>Yes</u>	<u>Yes</u>	<u>Yes</u> ^d	<u>No</u>	<u>Yes</u> ^d	<u>Yes</u>

a. Not required for lead-acid and nickel cadmium batteries at facilities under the exclusive control of communications utilities that comply with NFPA 76 and operate at less than 50 VAC and 60 VDC.

b. Protection shall be provided unless documentation acceptable to the fire code official is provided in accordance with Section 104.7.2 that provides justification why the protection is not necessary based on the technology used.

c. Applicable to vented (i.e. flooded) type nickel cadmium and lead acid batteries.

d. The thermal runaway protection is permitted to be part of a battery management system that has been evaluated with the battery as part of the evaluation to UL 1973.

1206.6.1 Exhaust ventilation. Where required by Table 1206.6 or elsewhere in this code, exhaust ventilation of rooms, areas, and walk-in units containing electrochemical ESS shall be provided in accordance with the International Mechanical Code and Section 1206.6.1.1 or 1206.6.1.2.

1206.6.1.1 Ventilation based upon LFL. The exhaust ventilation system shall be designed to limit the maximum concentration of flammable gas to 25 percent of the lower flammable limit (LFL) of the total volume of the room, area, or walk-in unit during the worst-case event of simultaneous charging of batteries at the maximum charge rate, in accordance with nationally recognized standards.

1206.6.1.2 Ventilation based upon exhaust rate. Mechanical exhaust ventilation shall be provided at a rate of not less than $1 \text{ ft}^3/\text{min}/\text{ft}^2$ ($5.1 \text{ L}/\text{sec}/\text{m}^2$) of floor area of the room, area, or walk-in unit. The ventilation shall be either continuous or shall be activated by a gas detection system in accordance with Section 1206.6.1.2.4.

1206.6.1.2.1 Standby power. Mechanical exhaust ventilation shall be provided with a minimum of two hours of standby power in accordance with Section 1203.2.5.

1206.6.1.2.2 Installation instructions. Required mechanical exhaust ventilation systems shall be installed in accordance with the manufacturer's installation instructions and the International Mechanical Code.

1206.6.1.2.3 Supervision. Required mechanical exhaust ventilation systems shall be supervised by an approved central station, proprietary or remote station service in accordance with NFPA 72, or shall initiate an audible and visible signal at an approved constantly attended on-site location.

1206.6.1.2.4 Gas detection system. Where required by Section 1206.6.1.2, rooms, areas, and walk-in units containing ESS shall be protected by an approved continuous gas detection system that complies with Section 916 and with the following:

1. The gas detection system shall be designed to activate the mechanical ventilation system when the level of flammable gas in the room, area, or walk-in unit exceeds 25 percent of the LFL.
2. The mechanical ventilation system shall remain on until the flammable gas detected is less than 25 percent of the LFL.
3. The gas detection system shall be provided with a minimum of 2 hours of standby power in accordance with Section 1203.2.6.
4. Failure of the gas detection system shall annunciate a trouble signal at an approved central station, proprietary or remote station service in accordance with NFPA 72, or shall initiate an audible and visible trouble signal at an approved constantly attended on-site location.

1206.6.2 Spill control and neutralization. Where required by Table 1206.6 or elsewhere in this code, areas containing free-flowing liquid electrolyte or hazardous materials shall be provided with spill control and neutralization in accordance with this section.

1206.6.2.1 Spill control. Spill control shall be provided to prevent the flow of liquid electrolyte or hazardous materials to adjoining rooms or areas. The method shall be capable of containing a spill from the single largest battery or vessel.

1206.6.2.2 Neutralization. An approved method to neutralize spilled liquid electrolyte shall be provided that is capable of neutralizing a spill from the largest battery or vessel to a pH between 5.0 and 9.0.

1206.6.3 Explosion control. Where required by Table 1206.6 or elsewhere in this code, explosion control complying

with Section 911 shall be provided for rooms, areas or walk-in units containing electrochemical ESS technologies.

Exceptions:

1. Where approved, explosion control is permitted to be waived by the fire code official based on large scale fire testing complying with Section 1206.1.5 which demonstrates that flammable gases are not liberated from electrochemical ESS cells or modules where tested in accordance with UL 9540A.
2. Where approved, explosion control is permitted to be waived by the fire code official based on documentation provided in accordance with Section 104.7 that demonstrates that the electrochemical ESS technology to be used does not have the potential to release flammable gas concentrations in excess of 25 percent of the LFL anywhere in the room, area, walk-in unit or structure under thermal runaway or other fault conditions.

1206.6.4 Safety caps. Where required by Table 1206.6 or elsewhere in this code, vented batteries and other ESS shall be provided with flame-arresting safety caps.

1206.6.5 Thermal runaway. Where required by Table 1206.6 or elsewhere in this code, batteries and other ESS shall be provided with a listed device or other approved method to prevent, detect and minimize the impact of thermal runaway.

1206.7 Indoor installations. Indoor ESS installations shall be in accordance with Sections 1206.7.1 through 1206.7.4.

1206.7.1 Dedicated use buildings. For the purpose of Table 1206.7 dedicated use ESS buildings shall be classified as Group F-1 occupancies and comply with all the following:

1. The building shall only be used for ESS, electrical energy generation, and other electrical grid related operations.
2. Occupants in the rooms and areas containing ESS are limited to personnel that operate, maintain, service, test and repair the ESS and other energy systems.
3. No other occupancy types shall be permitted in the building.
4. Administrative and support personnel shall be permitted in areas within the buildings that do not contain ESS, provided:
 - 4.1 The areas do not occupy more than 10 percent of the building area of the story in which they are located.
 - 4.2 A means of egress is provided from the incidental use areas to the public way that does not require occupants to traverse through areas containing ESS or other energy system equipment.

1206.7.2 Non-dedicated use buildings. For the purpose of Table 1206.7 non-dedicated use buildings include all buildings that contain ESS and do not comply with Section 1206.7.2 dedicated use building requirements.

**TABLE 1206.7
INDOOR ESS INSTALLATIONS**

<u>COMPLIANCE REQUIRED</u>	<u>DEDICATED USE BUILDINGS^a</u>	<u>NON-DEDICATED USE BUILDINGS^b</u>
<u>1206.4 General installation requirements</u>	<u>Yes</u>	<u>Yes</u>
<u>1206.5.1 Size and separation</u>	<u>Yes</u>	<u>Yes</u>
<u>1206.5.2 Maximum allowable quantities</u>	<u>No</u>	<u>Yes</u>
<u>1206.5.3 Elevation</u>	<u>Yes</u>	<u>Yes</u>
<u>1206.5.4 Smoke and automatic fire detection</u>	<u>Yes^c</u>	<u>Yes</u>
<u>1206.5.5 Fire suppression systems</u>	<u>Yes^d</u>	<u>Yes</u>
<u>1206.7.3 Dwelling units and sleeping units</u>	<u>NA</u>	<u>Yes</u>
<u>1206.7.4 Fire-resistance rated separations</u>	<u>Yes</u>	<u>Yes</u>
<u>1206.6 Technology specific protection</u>	<u>Yes</u>	<u>Yes</u>

NA = Not allowed.

a. See Section 1206.7.1.

b. See Section 1206.7.2.

c. Where approved by the fire code official, alarm signals are not required to be transmitted to a central station, proprietary or remote station service in accordance with NFPA 72, or a constantly attended location where local fire alarm annunciation is provided and trained personnel are always present.

d. Where approved by the fire code official, fire suppression systems are permitted to be omitted in dedicated use buildings located more than 100 feet (30.5 M) from buildings, lot lines, public ways, stored combustible materials, hazardous materials, high piled stock and other exposure hazards.

1206.7.3 Dwelling units and sleeping units. ESS shall not be installed in sleeping units or in habitable spaces of dwelling units.

1206.7.4 Fire-resistance rated separations. Rooms and areas containing ESS shall include fire-resistance rated separations as follows:

1. In dedicated use buildings, rooms and areas containing ESS shall be separated from areas in which administrative and support personnel are located.
2. In non-dedicated use buildings, rooms and areas containing ESS shall be separated from other areas in the building.

Separation shall be provided by 2 hour rated fire barriers constructed in accordance with Section 707 of the International Building Code and 2 hour rated horizontal assemblies constructed in accordance with Section 711 of the International Building Code, as appropriate.

1206.8 Outdoor installations. Outdoor installations shall be in accordance with Sections 1206.8.1 through 1206.8.3.

1206.8.1 Remote outdoor installations. For the purpose of Table 1206.8, remote outdoor installations include ESS located more than 100 feet (30.5 M) from buildings, lot lines, public ways, stored combustible materials, hazardous materials, high piled stock and other exposure hazards.

1206.8.2 Installations near exposures. For the purpose of Table 1206.8, installations near exposures include all outdoor ESS installations that do not comply with Section 1206.8.1 remote outdoor location requirements.

**TABLE 1206.8
OUTDOOR ESS INSTALLATIONS^a**

<u>COMPLIANCE REQUIRED</u>	<u>REMOTE INSTALLATIONS^a</u>	<u>INSTALLATIONS NEAR EXPOSURES^b</u>
<u>1206.4 All ESS installations</u>	<u>Yes</u>	<u>Yes</u>
<u>1206.5.1 Size and separation</u>	<u>No</u>	<u>Yes^c</u>
<u>1206.5.2 Maximum allowable quantities</u>	<u>No</u>	<u>Yes</u>
<u>1206.5.4 Smoke and automatic fire detection</u>	<u>Yes</u>	<u>Yes</u>
<u>1206.5.5 Fire suppression systems</u>	<u>Yes^d</u>	<u>Yes</u>
<u>1206.5.6 Maximum enclosure size</u>	<u>Yes</u>	<u>Yes</u>
<u>1206.5.7 Vegetation control</u>	<u>Yes</u>	<u>Yes</u>
<u>1206.5.8 Means of egress separation</u>	<u>Yes</u>	<u>Yes</u>
<u>1206.8.3 Clearance to exposures</u>	<u>Yes</u>	<u>Yes</u>
<u>1206.6 Technology specific protection</u>	<u>Yes</u>	<u>Yes</u>

a. See Section 1206.8.1.

b. See Section 1206.8.2.

c. In outdoor walk-in units, spacing is not required between ESS units and the walls of the enclosure.

d. Where approved by the fire code official, fire suppression systems are permitted to be omitted.

1206.8.3 Clearance to exposures. ESS located outdoors shall be separated by a minimum ten feet (3048 mm) from the following exposures:

1. Lot lines
2. Public ways
3. Buildings
4. Stored combustible materials
5. Hazardous materials
6. High-piled stock
7. Other exposure hazards

Exceptions:

1. Clearances are permitted to be reduced to 3 feet (914 mm) where a 1-hour free standing fire barrier, suitable for exterior use, and extending 5 feet (1.5 m) above and extending 5 feet (1.5 m) beyond the physical boundary of the ESS installation is provided to protect the exposure.
2. Clearances to buildings are permitted to be reduced to 3 feet (914 mm) where noncombustible exterior walls with no openings or combustible overhangs are provided on the wall adjacent to the ESS and the fire-resistance rating of the exterior wall is a minimum 2 hours.
3. Clearances to buildings are permitted to be reduced to 3 feet (914.4 mm) where a weatherproof enclosure constructed of noncombustible materials is provided over the ESS, and it has been demonstrated that a fire within the enclosure will not ignite combustible materials outside the enclosure based on large scale fire testing complying with Section 1206.1.5.

1206.9 Special installations. Rooftop and open parking garage ESS installations shall comply with Sections 1206.9.1 through 1206.9.6.

1206.9.1 Rooftop installations. For the purpose of Table 1206.9, rooftop ESS installations are those located on the roofs of buildings.

1206.9.2 Open parking garage installations. For the purpose of Table 1206.9, open parking garage ESS installations are those located in a structure or portion of a structure that complies with Section 406.5 of the International Building Code.

**TABLE 1206.9
SPECIAL ESS INSTALLATIONS**

<u>COMPLIANCE REQUIRED</u>	<u>ROOFTOPS</u> ^a	<u>OPEN PARKING GARAGES</u> ^b
<u>1206.4 All ESS installations</u>	<u>Yes</u>	<u>Yes</u>
<u>1206.5.1 Size and separation</u>	<u>Yes</u>	<u>Yes</u>
<u>1206.5.2 Maximum allowable quantities</u>	<u>Yes</u>	<u>Yes</u>
<u>1206.5.4 Smoke and automatic fire detection</u>	<u>Yes</u>	<u>Yes</u>
<u>1206.5.6 Maximum enclosure size</u>	<u>Yes</u>	<u>Yes</u>
<u>1206.5.8 Means of egress separation</u>	<u>Yes</u>	<u>Yes</u>
<u>1206.9.3 Clearance to exposures</u>	<u>Yes</u>	<u>Yes</u>
<u>1206.9.4 Fire suppression systems</u>	<u>Yes</u>	<u>Yes</u>
<u>1206.9.5 Rooftop installations</u>	<u>Yes</u>	No
<u>1206.9.6 Open parking garage installations</u>	No	<u>Yes</u>
<u>1206.6 Technology specific protection</u>	<u>Yes</u>	<u>Yes</u>

a. See Section 1206.9.1.

b. See Section 1206.9.2.

1206.9.3 Clearance to exposures. ESS located on rooftops and in open parking garages shall be separated by a minimum ten feet (3048 mm) from the following exposures:

1. Buildings, except the building on which rooftop ESS is mounted
2. Any portion of the building on which a rooftop system is mounted that is elevated above the rooftop on which the system is installed
3. Lot lines
4. Public ways
5. Stored combustible materials
6. Locations where motor vehicles can be parked
7. Hazardous materials
8. Other exposure hazards

Exceptions:

1. Clearances are permitted to be reduced to 3 feet (914 mm) where a 1-hour free standing fire barrier, suitable for exterior use, and extending 5 feet (1.5 m) above and extending 5 feet (1.5 m) beyond the physical boundary of the ESS installation is provided to protect the exposure.
2. Clearances are permitted to be reduced to 3 feet (914.4 mm) where a weatherproof enclosure constructed of noncombustible materials is provided over the ESS and it has been demonstrated that a fire within the enclosure will not ignite combustible materials outside the enclosure based on large scale fire testing complying with Section 1206.1.5.

1206.9.4 Fire suppression systems. ESS located in walk-in units on rooftops or in walk-in units in open parking garages shall be provided with automatic fire suppression systems within the ESS enclosure in accordance with Section 1206.5.5. Areas containing ESS other than walk-in units in open parking structures on levels not open above to the sky shall be provided with an automatic fire suppression system complying with Section 1206.5.5. Exception: A fire suppression system is not required in open parking garages if large scale fire testing complying with Section 1206.1.5 is provided that shows that a fire will not impact the exposures in Section 1206.9.3.

1206.9.5 Rooftop installations. ESS and associated equipment that are located on rooftops and not enclosed by building construction shall comply with the following:

1. Stairway access to the roof for emergency response and fire department personnel shall be provided either through a bulkhead from the interior of the building or a stairway on the exterior of the building.
2. Service walkways at least 5 feet (1524 mm) in width shall be provided for service and emergency personnel from the point of access to the roof to the system.
3. ESS and associated equipment shall be located from the edge of the roof a distance equal to at least the height of the system, equipment, or component but not less than 5 feet (1.5 m).
4. The roofing materials under and within 5 feet (1524 mm) horizontally from an ESS or associated equipment shall be noncombustible or shall have a Class A rating when tested in accordance with ASTM E108 or UL 790.
5. A Class I standpipe outlet shall be installed at an approved location on the roof level of the building or in the stairway bulkhead at the top level.
6. The ESS shall be the minimum of 10 feet from the fire service access point on the roof top.

1206.9.6 Open parking garages. ESS and associated equipment that are located in open parking garages shall comply with all of the following:

1. ESS shall not be located within 50 feet (15,240 mm) of air inlets for building HVAC systems.

Exception: This distance shall be permitted to be reduced to 25 feet (7,620 mm) if the automatic fire alarm system

monitoring the radiant-energy sensing detectors de-energizes the ventilation system connected to the air intakes upon detection of fire.

2. ESS shall not be located within 25 feet (7620 mm) of exits leading from the attached building where located on a covered level of the parking structure not directly open to the sky above.
3. 3. An approved fence with a locked gate or other approved barrier shall be provided to keep the general public at least five feet (1024 mm) from the outer enclosure of the ESS.

1206.10 Mobile ESS equipment and operations. Mobile ESS equipment and operations shall comply with Sections 1206.10.1 through 1206.10.7.7.

1206.10.1 Charging and storage. For the purpose of Section 1206.10, charging and storage covers the operation where mobile ESS are charged and stored so they are ready for deployment to another site, and where they are charged and stored after a deployment.

1206.10.2 Deployment. For the purpose of Section 1206.10, deployment covers operations where mobile ESS are located at a site other than the charging and storage site and are being used to provide power.

1206.10.3 Permits. Construction and operational permits shall be provided for charging and storage of mobile ESS and operational permits shall be provided for deployment of mobile ESS as required by Section 1206.1.2.

1206.10.4 Construction documents. Construction documents complying with Section 1206.3 shall be provided with the construction permit application for mobile ESS charging and storage locations.

1206.10.4.1 Deployment documents. The following information shall be provided with the operation permit applications for mobile ESS deployments:

1. Relevant information for the mobile ESS equipment and protection measures in the construction documents required by Section 1206.1.3.
2. Location and layout diagram of the area in which the mobile ESS is to be deployed, including a scale diagram of all nearby exposures.
3. Location and content of signage, including no smoking signs.
4. Description of fencing to be provided around the ESS, including locking methods.
5. Details on fire suppression, smoke and automatic fire detection, system monitoring, thermal management, exhaust ventilation, and explosion control, if provided.
6. For deployment, the intended duration of operation, including anticipated connection and disconnection times and dates.
7. Location and description of local staging stops during transit to the deployment site. See Section 1206.10.8.5.
8. Description of the temporary wiring, including connection methods, conductor type and size, and circuit overcurrent protection to be provided.
9. Description of how fire suppression system connections to water supplies or extinguishing agents are to be provided.
10. Contact information for personnel who are responsible for maintaining and servicing the equipment, and responding to emergencies as required by Section 1206.1.6.1.

1206.10.5 Approved locations. Locations where mobile ESS are charged, stored and deployed shall be restricted to the locations established on the construction and operational permits.

1206.10.6 Charging and storage. Installations where mobile ESS are charged and stored shall be treated as permanent ESS indoor or outdoor installations, and shall comply with the following sections, as applicable:

1. Indoor charging and storage shall comply with Section 1206.7.
2. Outdoor charging and storage shall comply with Section 1206.8.
3. Charging and storage on rooftops and in open parking garages shall comply with Section 1206.9.

Exceptions:

1. Electrical connections shall be permitted to be made using temporary wiring complying with the manufacturer's instructions, the UL 9540 listing, and NFPA 70.
2. Fire suppression system connections to the water supply shall be permitted to use approved temporary connections.

1206.10.7 Deployed mobile ESS requirements. Deployed mobile ESS equipment and operations shall comply with this section and Table 1206.10.

1206.10.7.1 Duration. The duration of mobile ESS deployment shall not exceed 30 days.

Exceptions:

1. Mobile ESS deployments that provide power for durations longer than 30 days shall comply with Section 1206.10.7.
2. Mobile ESS deployments shall not exceed 180 days unless additional operational permits are obtained.

1206.10.7.2 Restricted locations. Deployed mobile ESS operations shall not be located indoors, in covered parking garages, on rooftops, below grade, or under building overhangs.

1206.10.7.3 Clearance to exposures. Deployed mobile ESS shall be separated by a minimum 10 feet (3048 mm) from the following exposures:

1. Public ways
2. Buildings
3. Stored combustible materials
4. Hazardous materials
5. High-piled stock
6. Other exposure hazards

Deployed mobile ESS shall be separated by a minimum 50 feet (15.3 M) from public seating areas and from tents, canopies and membrane structures with an occupant load of 30 or more.

1206.10.7.4 Electrical connections. Electrical connections shall be made in accordance with the manufacturer's instructions and the UL 9540 listing. Temporary wiring for electrical power connections shall comply with NFPA 70. Fixed electrical wiring shall not be provided.

1206.10.7.5 Local staging. Mobile ESS in transit from the charging and storage location to the deployment location and back shall not be parked within 100 feet (30,480 mm) of an occupied building for more than one hour during transit, unless specifically approved by the fire code official when the permit is issued.

1206.10.7.6 Fencing. An approved fence with a locked gate or other approved barrier shall be provided to keep the general public at least five feet (1024 mm) from the outer enclosure of a deployed mobile ESS.

**TABLE 1206.10
MOBILE ENERGY STORAGE SYSTEMS (ESS)**

<u>COMPLIANCE REQUIRED</u>	<u>DEPLOYMENT</u> ^a
<u>1206.4 All ESS installations</u>	Yes ^b
<u>1206.5.1 Size and separation</u>	Yes ^c
<u>1206.5.2 Maximum allowable quantities</u>	Yes
<u>1206.5.4 Smoke and automatic fire detection</u>	Yes ^e
<u>1206.5.5 Fire suppression systems</u>	Yes ^d
<u>1206.5.6 Maximum enclosure size</u>	Yes
<u>1206.5.7 Vegetation control</u>	Yes
<u>1206.5.8 Means of egress separation</u>	Yes
<u>1206.6 Technology specific protection</u>	Yes

a. See Section 1206.10.2.

b. Mobile operations on wheeled vehicle or trailers shall not be required to comply with Section 1206.4.4 seismic and structural load requirements.

c. In walk-in units, spacing is not required between ESS units and the walls of the enclosure.

d. Fire suppression system connections to the water supply shall be permitted to use approved temporary connections.

e. Alarm signals are not required to be transmitted to an approved location for mobile ESS deployed 30 days or less.

1206.10.7.7 Smoking. Smoking shall be prohibited within 10 feet (3048 mm) of mobile ESS. Signs shall be posted in accordance with Section 310.

Delete without substitution:

~~**1206.1 Scope.** The provisions in this section are applicable to energy storage systems designed to provide electrical power to a building or facility. These systems are used to provide standby or emergency power, an uninterruptable power supply, load shedding, load sharing or similar capabilities.~~

~~**1206.2 Stationary storage battery systems.** Stationary storage battery systems having capacities exceeding the values shown in Table 1206.2 shall comply with Section 1206.2.1 through 1206.2.12.6, as applicable.~~

TABLE 1206.2
BATTERY STORAGE SYSTEM THRESHOLD QUANTITIES.

BATTERY TECHNOLOGY	CAPACITY^a
Flow batteries ^b	20 kWh
Lead acid, all types	70 kWh
Lithium, all types	20 kWh
Nickel cadmium (Ni-Cd)	70 kWh
Sodium, all types	20 kWh ^c
Other battery technologies	10 kWh

For SI: 1 kilowatt hour = 3.6 megajoules.

- a. For batteries rated in amp hours, kWh shall equal rated voltage times amp hour rating divided by 1000.
- b. Shall include vanadium, zinc bromine, polysulfide bromide, and other flowing electrolyte type technologies.
- c. 70 kWh for sodium ion technologies.

1206.2.1 Permits. Permits shall be obtained for the installation and operation of stationary storage battery systems in accordance with Section 105.7.2.

1206.2.2 Construction documents. The following information shall be provided with the permit application:

1. Location and layout diagram of the room in which the stationary storage battery system is to be installed.
2. Details on hourly fire-resistance-rated assemblies provided.
3. Quantities and types of storage batteries and battery systems.
4. Manufacturer's specifications, ratings and listings of storage batteries and battery systems.
5. Details on energy management systems.
6. Location and content of signage.
7. Details on fire-extinguishing, smoke detection and ventilation systems.
8. Rack storage arrangement, including seismic support criteria.

1206.2.3 Hazard mitigation analysis. A failure modes and effects analysis (FMEA) or other approved hazard mitigation analysis shall be provided in accordance with Section 104.7.2 under any of the following conditions:

1. Battery technologies not specifically identified in Table 1206.2 are provided.
2. More than one stationary storage battery technology is provided in a room or indoor area where there is a potential for adverse interaction between technologies.
3. Where allowed as a basis for increasing maximum allowable quantities in accordance with Section 1206.2.9.

1206.2.3.1 Fault condition. The hazard mitigation analysis shall evaluate the consequences of the following failure modes, and others deemed necessary by the *fire code official*. Only single failure modes shall be considered:

1. Thermal runaway condition in a single battery storage rack, module or array.
2. Failure of any energy management system.
3. Failure of any required ventilation system.
4. Voltage surges on the primary electric supply.
5. Short circuits on the load side of the stationary battery storage system.
6. Failure of the smoke detection, fire extinguishing or gas detection system.
7. Spill neutralization not being provided or failure of the secondary containment system.

1206.2.3.2 Analysis approval. The *fire code official* is authorized to approve the hazardous mitigation analysis provided that the hazard mitigation analysis demonstrates all of the following:

1. Fires or explosions will be contained within unoccupied battery storage rooms for the minimum duration of the fire resistance rated walls identified in Table 509.1 of the International Building Code.
2. Fires and explosions in battery cabinets in occupied work centers will be detected in time to allow occupants within the room to evacuate safely.
3. Toxic and highly toxic gases released during fires and other fault conditions shall not reach concentrations in excess of Immediately Dangerous to Life or Health (IDLH) levels in the building or adjacent means of egress routes during the time deemed necessary to evacuate from that area.
4. Flammable gases released from batteries during charging, discharging and normal operation shall

not exceed 25 percent of their lower flammability limit (LFL).

5. Flammable gases released from batteries during fire, overcharging and other abnormal conditions shall not create an explosion hazard that will injure occupants or emergency responders.

1206.2.3.3 Additional protection measures. Construction, equipment and systems that are required for the stationary storage battery system to comply with the hazardous mitigation analysis, including but not limited to those specifically described in Section 1206.2, shall be installed, maintained and tested in accordance with nationally recognized standards and specified design parameters.

1206.2.4 Seismic and structural design. Stationary storage battery systems shall comply with the seismic design requirements in Chapter 16 of the International Building Code, and shall not exceed the floor loading limitation of the building.

1206.2.5 Vehicle impact protection. Where stationary storage battery systems are subject to impact by a motor vehicle, including fork lifts, vehicle impact protection shall be provided in accordance with Section 312.

1206.2.6 Combustible storage. Combustible materials not related to the stationary storage battery system shall not be stored in battery rooms, cabinets or enclosures. Combustible materials in occupied work centers covered by Section 1206.2.8.5 shall not be stored less than 3 feet (915 mm) from battery cabinets.

1206.2.7 Testing, maintenance and repair. Storage batteries and associated equipment and systems shall be tested and maintained in accordance with the manufacturer's instructions. Any storage batteries or system components used to replace existing units shall be compatible with the battery charger, energy management systems, other storage batteries and other safety systems. Introducing other types of storage batteries into the stationary storage battery system or other types of electrolytes into flow battery systems shall be treated as a new installation and require approval by the *fire code official* before the replacements are introduced into service.

1206.2.8 Location and construction. Rooms and areas containing stationary storage battery systems shall be designed, located and constructed in accordance with Sections 1206.2.8.1 through 1206.2.8.7.4.

1206.2.8.1 Location. Stationary storage battery systems shall not be located in areas where the floor is located more than 75 feet (22 860 mm) above the lowest level of fire department vehicle access, or where the floor level is more than 30 feet (9144 mm) below the finished floor of the lowest level of exit discharge.

Exceptions:

1. Lead acid and nickel cadmium stationary storage battery systems.
2. Installations on noncombustible rooftops of buildings exceeding 75 feet (22 860 mm) in height that do not obstruct fire department rooftop operations, where *approved by the fire code official*.

1206.2.8.2 Separation. Rooms containing stationary storage battery systems shall be separated from other areas of the building in accordance with Section 509.1 of the International Building Code. Battery systems shall be allowed to be in the same room with the equipment they support.

1206.2.8.3 Stationary battery arrays. Storage batteries, prepackaged stationary storage battery systems and preengineered stationary storage battery systems shall be segregated into stationary battery arrays not exceeding 50 kWh (180 megajoules) each. Each stationary battery array shall be spaced not less than 3 feet (914 mm) from other stationary battery arrays and from walls in the storage room or area. The storage arrangements shall comply with Chapter 10.

Exceptions:

1. Lead acid and nickel cadmium storage battery arrays.
2. Listed preengineered stationary storage battery systems and prepackaged stationary storage battery systems shall not exceed 250 kWh (900 megajoules) each.
3. The fire code official is authorized to approve listed, preengineered and prepackaged battery arrays with larger capacities or smaller battery array spacing if large scale fire and fault condition testing conducted or witnessed and reported by an approved testing laboratory is provided showing that a fire involving one array will not propagate to an adjacent array, and be contained within the room for a duration equal to the fire-resistance rating of the room separation specified in Table 509 of the International Building Code.

1206.2.8.4 Separate rooms. Where stationary batteries are installed in a separate equipment room that can be accessed only by authorized personnel, they shall be permitted to be installed on an open rack for ease of maintenance.

1206.2.8.5 Occupied work centers. Where stationary storage batteries are located in an occupied work center, they shall be housed in a noncombustible cabinet or other enclosure to prevent access by unauthorized personnel.

1206.2.8.5.1 Cabinets. Where stationary batteries are contained in cabinets in occupied work centers, the cabinet enclosures shall be located within 10 feet (3048 mm) of the equipment that they support.

1206.2.8.6 Signage. Approved signs shall be provided on doors or in locations near entrances to stationary storage battery system rooms and shall include the following or equivalent:

1. The room contains energized battery systems.
2. The room contains energized electrical circuits.
3. The additional markings required in Section 1206.2.12 for the types of storage batteries contained within the room.

Exception: Existing stationary storage battery systems shall be permitted to include the signage required at the time it was installed.

1206.2.8.6.1 Electrical disconnects. Where the stationary storage battery system disconnecting means is not within sight of the main service disconnecting means, placards or directories shall be installed at the location of the main service disconnecting means indicating the location of stationary storage battery system disconnecting means in accordance with NFPA 70.

1206.2.8.6.2 Cabinet signage. Battery storage cabinets provided in occupied work centers in accordance with Section 1206.2.8.5 shall have exterior labels that identify the manufacturer and model number of the system and electrical rating (voltage and current) of the contained battery system. There shall be signs within the cabinet that indicate the relevant electrical and chemical hazards, as required by Section 1206.2.12.

1206.2.8.7 Outdoor installations. Stationary storage battery systems located outdoors shall comply with Sections 1206.2.8.7 through 1206.2.8.7.4, in addition to all applicable requirements of Section 1206.2. Installations in outdoor enclosures or containers that can be occupied for servicing, testing, maintenance and other functions shall be treated as battery storage rooms.

Exception: Stationary battery arrays in noncombustible containers shall not be required to be spaced 3 feet (914 mm) from the container walls.

1206.2.8.7.1 Separation. Stationary storage battery systems located outdoors shall be separated by a minimum 5 feet (1524 mm) from the following:

1. Lot lines.
2. Public ways.
3. Buildings.
4. Stored combustible materials.
5. Hazardous materials.
6. High-piled stock.
7. Other exposure hazards.

Exception: The fire code official is authorized to approve smaller separation distances if large-scale fire and fault condition testing conducted or witnessed and reported by an approved testing laboratory is provided showing that a fire involving the system will not adversely impact occupant egress from adjacent buildings, or adversely impact adjacent stored materials or structures.

1206.2.8.7.2 Means of egress. Stationary storage battery systems located outdoors shall be separated from any means of egress as required by the fire code official to ensure safe egress under fire conditions, but not less than 10 feet (3048 mm).

Exception: The fire code official is authorized to approve lesser separation distances if large-scale fire and fault condition testing conducted or witnessed and reported by an approved testing laboratory is provided showing that a fire involving the system will not adversely impact occupant egress.

~~1206.2.8.7.3 Security of outdoor areas.~~ Outdoor areas in which stationary storage battery systems are located shall be secured against unauthorized entry and safeguarded in an approved manner.

~~1206.2.8.7.4 Walk-in units.~~ Where a stationary storage battery system includes an outer enclosure, the unit shall only be entered for inspection, maintenance and repair of batteries and electronics, and shall not be occupied for other purposes.

~~1206.2.9 Maximum allowable quantities.~~ *Fire areas* within buildings containing stationary storage battery systems exceeding the maximum allowable quantities in Table 1206.2.9 shall comply with all applicable Group H occupancy requirements in this code and the International Building Code.

~~Exception:~~ Where approved by the *fire code official*, areas containing stationary storage batteries that exceed the amounts in Table 1206.2.9 shall be treated as incidental use areas and not Group H occupancies based on a hazardous mitigation analysis in accordance with Section 1206.2.3 and large-scale fire and fault condition testing conducted or witnessed and reported by an approved testing laboratory.

**TABLE 1206.2.9
MAXIMUM ALLOWABLE BATTERY QUANTITIES**

BATTERY TECHNOLOGY	MAXIMUM ALLOWABLE QUANTITIES^a	GROUP H OCCUPANCY
Flow batteries ^b	600 kWh	Group H-2
Lead acid, all types	Unlimited	Not Applicable
Lithium, all types	600 kWh	Group H-2
Nickel cadmium (Ni-Cd)	Unlimited	Not Applicable
Sodium, all types	600 kWh	Group H-2
Other battery technologies	200 kWh	Group H-2 ^c

For SI: 1 kilowatt hour = 3.6 megajoules.

- a. For batteries rated in amp-hours, kilowatt-hours (kWh) shall equal rated battery voltage times the amp-hour rating divided by 1,000.
- b. Shall include vanadium, zinc-bromine, polysulfide-bromide, and other flowing electrolyte-type technologies.
- c. Shall be a Group H-4 occupancy if the fire code official determines that a fire or thermal runaway involving the battery technology does not represent a significant fire hazard.

1206.2.9.1 Mixed battery systems. Where areas within buildings contain different types of storage battery technologies, the total aggregate quantities of batteries shall be determined based on the sum of percentages of each battery type quantity divided by the maximum allowable quantity of each battery type. If the sum of the percentages exceeds 100 percent, the area shall be treated as a Group H occupancy in accordance with Table 1206.2.9.

1206.2.10 Storage batteries and equipment. The design and installation of storage batteries and related equipment shall comply with Sections 1206.2.10.1 through 1206.2.10.8.

1206.2.10.1 Listings. Storage batteries and battery storage systems shall comply with the following:

1. Storage batteries shall be listed in accordance with UL 1973.
2. Prepackaged and preengineered stationary storage battery systems shall be listed in accordance with UL 9540.

Exception: Lead-acid batteries are not required to be listed.

1206.2.10.2 Prepackaged and preengineered systems. Prepackaged and preengineered stationary storage battery systems shall be installed in accordance with their listing and the manufacturer's instructions.

1206.2.10.3 Energy management system. An approved energy management system shall be provided for battery technologies other than lead-acid and nickel-cadmium for monitoring and balancing cell voltages, currents and temperatures within the manufacturer's specifications. The system shall transmit an alarm signal to an approved location if potentially hazardous temperatures or other conditions such as short circuits, over-voltage or under-voltage are detected.

1206.2.10.4 Battery chargers. Battery chargers shall be compatible with the battery chemistry and the manufacturer's electrical ratings and charging specifications. Battery chargers shall be listed and labeled in accordance with UL 1564 or provided as part of a listed preengineered or prepackaged stationary storage battery system.

1206.2.10.5 Inverters. Inverters shall be listed and labeled in accordance with UL 1741. Only inverters listed and labeled for utility interactive system use and identified as interactive shall be allowed to operate in parallel with the electric utility power system to supply power to common loads.

1206.2.10.6 Safety caps. Vented batteries shall be provided with flame-arresting safety caps.

1206.2.10.7 Thermal runaway. Where required by Section 1206.2.12, storage batteries shall be provided with a listed device or other approved method to prevent, detect and control thermal runaway.

1206.2.10.8 Toxic and highly toxic gas. Stationary storage battery systems that have the potential to release toxic and highly toxic gas during charging, discharging and normal use conditions shall comply with Chapter 60.

1206.2.11 Fire-extinguishing and detection systems. Fire-extinguishing and detection systems shall be provided in accordance with Sections 1206.2.11.1 through 1206.2.11.5.

1206.2.11.1 Fire-extinguishing systems. Rooms containing stationary storage battery systems shall be equipped with an *automatic sprinkler system* installed in accordance with Section 903.3.1.1. Commodity classifications for specific technologies of storage batteries shall be in accordance with Chapter 5 of NFPA 13. If the storage battery types are not addressed in Chapter 5 of NFPA 13, the *fire code official* is authorized to approve the fire-extinguishing system based on full-scale fire and fault condition testing conducted or witnessed and reported by an *approved laboratory*.

Exception: Spaces or areas containing stationary storage battery systems used exclusively for telecommunications equipment in accordance with Section 903.2.

1206.2.11.1.1 Alternative fire-extinguishing systems. Battery systems that utilize water-reactive materials shall be protected by an approved alternative automatic fire-extinguishing system in accordance with Section 904. The system shall be listed for protecting the type, arrangement and quantities of storage batteries in the room. The fire code official shall be permitted to approve the alternative fire-extinguishing system based on full-scale fire and fault condition testing conducted or witnessed and reported by an approved laboratory.

1206.2.11.2 Smoke detection system. An approved automatic smoke detection system shall be installed in rooms containing stationary storage battery systems in accordance with Section 907.2.

1206.2.11.3 Ventilation. Where required by Section 1206.2.3 or 1206.2.12, ventilation of rooms containing stationary storage battery systems shall be provided in accordance with the International Mechanical Code and one of the following:

1. The ventilation system shall be designed to limit the maximum concentration of flammable gas to 25 percent of the lower flammability limit, or for hydrogen, 1.0 percent of the total volume of the room.
2. Continuous ventilation shall be provided at a rate of not less than 1 cubic foot per minute (cfm) per square foot [$0.00508 \text{ m}^3/(\text{s} \cdot \text{m}^2)$] of floor area, but not less than 150 cfm ($4 \text{ m}^3/\text{min}$).

The exhaust system shall be designed to provide air movement across all parts of the floor for gases having a vapor density greater than air and across all parts of the vault ceiling for gases having a vapor density less than air.

1206.2.11.3.1 Cabinet ventilation. Where cabinets located in occupied spaces contain storage batteries that are required by Section 1206.2.3 or 1206.2.12 to be provided with ventilation, the cabinet shall be provided with ventilation in accordance with Section 1206.2.11.3.

1206.2.11.3.2 Supervision. Required mechanical ventilation systems for rooms and cabinets containing storage batteries shall be supervised by an approved central station, proprietary or remote station service or shall initiate an audible and visual signal at an approved constantly attended on-site location.

1206.2.11.4 Gas detection system. Where required by Section 1206.2.3 or 1206.2.12, rooms containing stationary storage battery systems shall be protected by a gas detection system complying with Section 916. The gas detection system shall be designed to activate where the level of flammable gas exceeds 25 percent of the lower flammable limit (LFL), or where the level of toxic or highly toxic gas exceeds one-half of the IDLH.

1206.2.11.4.1 System activation. Activation of the gas detection system shall result in all the following:

1. Initiation of distinct audible and visible alarms in the battery storage room.
2. Transmission of an alarm to an approved location.
3. De-energizing of the battery charger.
4. Activation of the mechanical ventilation system, where the system is interlocked with the gas detection system.

Exception: Lead-acid and nickel-cadmium stationary storage battery systems shall not be required to comply with Items 1, 2 and 3.

1206.2.11.5 Spill control and neutralization. Where required by Section 1206.2.12, approved methods and materials shall be provided for the control and neutralization of spills of electrolyte or other hazardous materials in areas containing stationary storage batteries as follows:

1. For batteries with free-flowing electrolyte, the method and materials shall be capable of neutralizing a spill of the total capacity from the largest cell or block to a pH between 5.0 and 9.0.
2. For batteries with immobilized electrolyte, the method and material shall be capable of neutralizing a spill of 3.0 percent of the capacity of the largest cell or block in the room to a pH between 5.0 and 9.0.

1206.2.12 Specific battery-type requirements. This section includes requirements applicable to specific types of storage batteries. Stationary storage battery systems with more than one type of storage battery shall comply with requirements applicable to each battery type.

1206.2.12.1 Lead-acid storage batteries. Stationary storage battery systems utilizing lead-acid storage batteries shall comply with the following:

1. ~~Ventilation shall be provided in accordance with Section 1206.2.11.3.~~
2. ~~Spill control and neutralization shall be in accordance with Section 1206.2.11.5.~~
3. ~~Thermal runaway protection shall be provided for valve-regulated lead acid (VRLA) storage batteries in accordance with Section 1206.2.10.7.~~
4. ~~The signage in Section 1206.2.8.6 shall indicate the room contains lead-acid batteries.~~

~~**1206.3.5.1 Fire-extinguishing systems.** Rooms containing capacitor energy storage systems shall be equipped with an automatic sprinkler system installed in accordance with Section 903.3.1.1. Commodity classifications for specific capacitor technologies shall be in accordance with Chapter 5 of NFPA 13. If the capacitor types are not addressed in Chapter 5 of NFPA 13, the fire code official is authorized to approve the automatic sprinkler system based on full-scale fire and fault condition testing conducted by an approved laboratory.~~

~~**1206.2.12.2 Nickel-cadmium (Ni-Cd) storage batteries.** Stationary storage battery systems utilizing nickel-cadmium (Ni-Cd) storage batteries shall comply with the following:~~

1. ~~Ventilation shall be provided in accordance with Section 1206.2.11.3.~~
2. ~~Spill control and neutralization shall be in accordance with Section 1206.2.11.5.~~
3. ~~Thermal runaway protection shall be provided for valve-regulated sealed nickel-cadmium storage batteries in accordance with Section 1206.2.10.7.~~
4. ~~The signage in Section 1206.2.8.6 shall indicate the room contains nickel-cadmium batteries.~~

~~**1206.2.12.3 Lithium-ion storage batteries.** The signage in Section 1206.2.8.6 shall indicate the type of lithium batteries contained in the room.~~

~~**1206.3.2.5 Electrical disconnects.** Where the capacitor energy storage system disconnecting means is not within sight of the main service disconnecting means, placards or directories shall be installed at the location of the main service disconnecting means identifying the location of the capacitor energy storage system disconnecting means in accordance with NFPA 70.~~

~~**1206.2.12.4 Sodium-beta storage batteries.** Stationary storage battery systems utilizing sodium-beta storage batteries shall comply with the following:~~

1. ~~Ventilation shall be provided in accordance with Section 1206.2.11.3.~~
2. ~~The signage in Section 1206.2.8.6 shall indicate the type of sodium batteries in the room and include the instructions, "APPLY NO WATER."~~

~~**1206.3.2.6 Outdoor installation.** Capacitor energy systems located outdoors shall comply with Sections 1206.3.2.6 through 1206.3.2.6.4 in addition to all applicable requirements of Section 1206.3. Installations in outdoor enclosures or containers that can be occupied for servicing, testing, maintenance and other functions shall be treated as capacitor storage rooms.~~

~~**Exception:** Capacitor arrays in noncombustible containers shall not be required to be spaced 3 feet (914 mm) from the container walls.~~

~~**1206.3.2.6.1 Separation.** Capacitor energy systems located outdoors shall be not less than 5 feet (1524 mm) from the following:~~

1. ~~Lot lines.~~
2. ~~Public ways.~~
3. ~~Buildings.~~
4. ~~Stored combustible materials.~~
5. ~~Hazardous materials.~~
6. ~~High-piled stock.~~
7. ~~Other exposure hazards.~~

~~**Exception:** The fire code official is authorized to approve lesser separation distances if large-scale fire and fault condition testing conducted or witnessed and reported by an approved testing laboratory is provided showing that a fire involving the system will not adversely impact occupant egress from adjacent buildings, or adversely impact adjacent stored materials or structures.~~

1206.2.12.5 Flow storage batteries. Stationary storage battery systems utilizing flow storage batteries shall comply with the following:

1. Ventilation shall be provided in accordance with Section 1206.2.11.3.
2. Spill control and neutralization shall be in accordance with Section 1206.2.11.5.
3. The signage required in Section 1206.2.8.6 shall indicate the type of flow batteries in the room.

1206.3.2.6.3 Security of outdoor areas. Outdoor areas in which capacitor energy storage systems are located shall be secured against unauthorized entry and safeguarded in an approved manner.

1206.3.2.1 Location. Capacitor energy storage systems shall not be located in areas where the floor is located more than 75 feet (22 860 mm) above the lowest level of fire department vehicle access, or where the floor level is more than 30 feet (9144 mm) below the finished floor of the lowest level of exit discharge.

1206.3.4.4 Capacitor chargers. Capacitor chargers shall be compatible with the capacitor manufacturer's electrical ratings and charging specifications. Capacitor chargers shall be listed and labeled in accordance with UL 1564 or provided as part of a listed preengineered or prepackaged capacitor energy storage system.

1206.2.12.6 Other battery technologies. Stationary storage battery systems utilizing battery technologies other than those described in Sections 1206.2.12.1 through 1206.2.12.5 shall comply with the following:

1. Gas detection systems complying with Section 916 shall be provided in accordance with Section 1206.2.11.4 where the batteries have the potential to produce toxic or highly toxic gas in the storage room or cabinet in excess of the permissible exposure limits (PEL) during charging, discharging and normal system operation.
2. Mechanical ventilation shall be provided in accordance with Section 1206.2.11.3.
3. Spill control and neutralization shall be in accordance with Section 1206.2.11.5.
4. In addition to the signage required in Section 1206.2.8.6, the marking shall identify the type of batteries present, describe the potential hazards associated with the battery type, and indicate that the room contains energized electrical circuits.

1206.3.2.2 Separation. Rooms containing capacitor energy storage systems shall be separated from the following occupancies by fire barriers or horizontal assemblies, or both, constructed in accordance with the International Building Code:

1. Group B, F, M, S and U occupancies by 1-hour fire resistance-rated construction.
2. Group A, E, I and R occupancies by 2-hour fire resistance-rated construction.

1206.3.2.6.4 Walk-in units. Where a capacitor energy storage system includes an outer enclosure, the unit shall only be entered for inspection, maintenance and repair of batteries and electronics, and shall not be occupied for other purposes.

1206.3.4.1 Listing. Capacitors and capacitor energy storage systems shall comply with the following:

1. Capacitors shall be listed in accordance with UL 1973.
2. Prepackaged and preengineered stationary capacitor energy storage systems shall be listed in accordance with UL 9540.

1206.3.4.5 Toxic and highly toxic gas. Capacitor energy storage systems that have the potential to release toxic and highly toxic materials during charging, discharging and normal use conditions shall comply with Chapter 60.

1206.3.5.1.1 Alternative fire-extinguishing systems. Capacitor energy storage systems that utilize water-reactive materials shall be protected by an approved alternative automatic fire-extinguishing system in accordance with Section 904. The system shall be listed for protecting the type, arrangement and quantities of capacitors in the room. The fire code official shall be permitted to approve the system based on full-scale fire and fault condition testing conducted by an approved laboratory.

1206.3 Capacitor energy storage systems. Capacitor energy storage systems having capacities exceeding 3 kWh (10.8 megajoules) shall comply with Sections 1206.3 through 1206.3.2.6.1.

~~**Exception:** Capacitors regulated by NFPA 70, Chapter 460, and capacitors included as a component part of other listed electrical equipment are not required to comply with this section.~~

~~**1206.3.2.3 Capacitor arrays.** Capacitor energy storage systems shall be segregated into capacitor arrays not exceeding 50 kWh (180 megajoules) each. Each array shall be spaced not less than 3 feet (914 mm) from other arrays and from walls in the storage room or area. The storage arrangements shall comply with Chapter 10.~~

~~**Exception:** Capacitor energy storage systems in noncombustible containers located outdoors shall not be required to be spaced 3 feet (914 mm) from the container walls.~~

~~**1206.3.3 Maximum allowable quantities.** Fire areas within buildings containing capacitor energy storage systems that exceed 600 kWh of energy capacity shall comply with all applicable Group H occupancy requirements in this code and the International Building Code.~~

~~**1206.3.4.2 Prepackaged and preengineered systems.** In addition to other applicable requirements of this code, prepackaged and preengineered capacitor energy storage systems shall be installed in accordance with their listing and the manufacturer's instructions.~~

~~**1206.3.5.3 Ventilation.** Where capacitors release flammable gases during normal operating conditions, ventilation of rooms containing capacitor energy storage systems shall be provided in accordance with the International Mechanical Code and one of the following:~~

- ~~1. The ventilation system shall be designed to limit the maximum concentration of flammable gas to 25 percent of the lower flammability limit.~~
- ~~2. Continuous ventilation shall be provided at a rate of not less than 1 cubic foot per minute (cfm) per square foot [$0.00508 \text{ m}^3/(\text{s} \cdot \text{m}^2)$] of floor area, but not less than 150 cfm (4 m^3/min).~~

~~The exhaust system shall be designed to provide air movement across all parts of the floor for gases having a vapor density greater than air and across all parts of the ceiling for gases having a vapor density less than air.~~

~~**1206.3.5.3.1 Supervision.** Required mechanical ventilation systems for rooms containing capacitor energy storage systems shall be supervised by an approved central station, proprietary or remote station service, or shall initiate an audible and visible signal at an approved, constantly attended on-site location.~~

~~**1206.3.1 Permits.** Permits shall be obtained for the installation of capacitor energy storage systems in accordance with Section 105.7.3.~~

~~**1206.3.2.4 Signage.** Approved signs shall be provided on doors or in locations adjacent to the entrances to capacitor energy storage system rooms and shall include the following or equivalent verbiage and information:~~

- ~~1. "CAPACITOR ENERGY STORAGE ROOM."~~
- ~~2. "THIS ROOM CONTAINS ENERGIZED ELECTRICAL CIRCUITS."~~
- ~~3. An identification of the type of capacitors present and the potential hazards associated with the capacitor type.~~

~~**1206.3.4.3 Energy management system.** An approved energy management system shall be provided for monitoring and balancing capacitor voltages, currents and temperatures within the manufacturer's specifications. The system shall transmit an alarm signal to an approved location if potentially hazardous temperatures or other conditions such as short circuits, over voltage or under voltage are detected.~~

~~**1206.3.5.2 Smoke detection system.** An approved automatic smoke detection system shall be installed in rooms containing capacitor energy storage systems in accordance with Section 907.2.~~

~~**1206.3.5.4 Spill control and neutralization.** Where capacitors contain liquid electrolyte, approved methods and materials shall be provided for the control and neutralization of spills of electrolyte or other hazardous materials in areas containing capacitors as follows:~~

- ~~1. For capacitors with free flowing electrolyte, the method and materials shall be capable of neutralizing a spill of the total capacity from the largest cell or block to a pH between 5.0 and 9.0.~~
- ~~2. For capacitors with immobilized electrolyte, the method and material shall be capable of neutralizing a spill of 3.0 percent of the capacity of the largest cell or block in the room to a pH between 5.0 and 9.0.~~

~~**1206.3.2.6.2 Means of egress.** Capacitor energy storage systems located outdoors shall be separated from any means of egress as required by the fire code official to ensure safe egress under fire conditions, but not less than 10 feet (3048 mm).~~

~~**Exception:** The fire code official is authorized to approve lesser separation distances if large scale fire and fault condition testing conducted or witnessed and reported by an approved testing laboratory is provided showing that a fire involving the system will not adversely impact occupant egress.~~

~~**1206.3.6 Testing, maintenance and repair.** Capacitors and associated equipment and systems shall be tested and maintained in accordance with the manufacturer's instructions. Any capacitors or system components used to replace existing units shall be compatible with the capacitor charger, energy management systems, other capacitors, and other safety systems. Introducing different capacitor technologies into the capacitor energy storage system shall be treated as a new installation and require approval by the fire code official before the replacements are introduced into service.~~

~~**1206.3.2 Location and construction.** Rooms and areas containing capacitor energy storage systems shall be designed, located and constructed in accordance with Sections 1206.3.2 through 1206.3.2.5.~~

~~**1206.3.4 Capacitors and equipment.** The design and installation of capacitor energy storage systems and related equipment shall comply with Sections 1206.3.4.1 through 1206.3.4.5.~~

~~**1206.3.5 Fire-extinguishing and detection systems.** Fire-extinguishing and smoke detection systems shall be provided in capacitor energy storage system rooms in accordance with Sections 1206.3.5.1 through 1206.3.5.2.~~

Add new standard(s) follows:

NFPA

National Fire Protection Association
1 Batterymarch Park
Quincy MA 02169-7471

76 - 16.:

Standard for the Fire Protection of Telecommunications Facilities

UL

Underwriters Laboratories LLC
333 Pfingsten Road
Northbrook IL 60062

1974 -17:

Evaluation for Re-purposing Batteries

9540A-17:

Standard for Safety Test Method for Evaluating Thermal Runaway Fire Propagation in Battery Energy Storage Systems

2018 International Building Code

**[F] TABLE 414.5.1
EXPLOSION CONTROL REQUIREMENTS^{a, h}**

MATERIAL	CLASS	EXPLOSION CONTROL METHODS	
		Barricade construction	Explosion (deflagration) venting or explosion (deflagration) prevention systems ^b
HAZARD CATEGORY			
Combustible dusts ^c	-	Not Required	Required
Cryogenic flammables	-	Not Required	Required
Explosives	Division 1.1	Required	Not Required
	Division 1.2	Required	Not Required
	Division 1.3	Not Required	Required
	Division 1.4	Not Required	Required
	Division 1.5	Required	Not Required
	Division 1.6	Required	Not Required
Flammable gas	Gaseous	Not Required	Required
	Liquefied	Not Required	Required
Flammable liquid	IA ^d	Not Required	Required
	IB ^e	Not Required	Required
Organic peroxides	U	Required	Not Permitted
	I	Required	Not Permitted
Oxidizer liquids and solids	4	Required	Not Permitted
Pyrophoric gas	-	Not Required	Required
Unstable (reactive)	4	Required	Not Permitted
	3 Detonable	Required	Not Permitted
	3 Nondetonable	Not Required	Required
Water-reactive liquids and solids	3	Not Required	Required
	2 ^g	Not Required	Required
SPECIAL USES			
Acetylene generator rooms	-	Not Required	Required
<u>Electrochemical energy storage systems^l</u>	---	<u>Not Required</u>	<u>Required</u>
Grain processing	-	Not Required	Required
Liquefied petroleum gas-distribution facilities	-	Not Required	Required
Where explosion hazards exist ^f	Detonation	Required	Not Permitted
	Deflagration	Not Required	Required

- a. See Section 414.1.3.
- b. See the International Fire Code.
- c. As generated during manufacturing or processing.
- d. Storage or use.
- e. In open use or dispensing.
- f. Rooms containing dispensing and use of hazardous materials where an explosive environment can occur because of the characteristics or nature of the hazardous materials or as a result of the dispensing or use process.
- g. A method of explosion control shall be provided where Class 2 water-reactive materials can form potentially explosive mixtures.
- h. Explosion venting is not required for Group H-5 fabrication areas complying with Section 415.11.1 and the International Fire Code.
- i. Where explosion control is required in Section 1206.6 of the International Fire Code.

Reason:

The addition of energy storage system (ESS) requirements into the 2018 code was an initial effort to address safety hazards associated with the increased use of lithium-ion batteries, capacitors and other modern energy storage system (ESS) technologies for an expanded number of grid related energy storage applications. The new requirements were a huge step toward addressing modern ESS technologies and grid based applications. However as written the requirements made it difficult to apply appropriate safety requirements for different installations, each with their own risks and exposures. Case in point, a lead acid battery ESS installation in an unmanned rural telecommunications repeater doesn't present the same risks and exposures as a lithium-ion battery ESS installation in a mixed occupancy high rise in an urban area.

Since the 2018 ESS requirements were developed there has been a lot of work done by private and government stakeholders to enhance ESS installation requirements, including the initial drafting of the NFPA 855 Energy Storage System standard. The Fire Code Action Committee's ESS work group, which includes 45+ code officials, manufacturers, users and industry experts identified several areas in the 2018 code that needed to be addressed to provide requirements that better address the hazards and exposures associated with various types of ESS installations, technologies and operations.

This section rewrite retains many of the basic protection concepts in the 2018 code, but also provide customized requirements for different types of installations and different types of ESS technologies in use today. We chose to replace the section in its entirety, rather than trying to edit existing text. Explanations of some of the more significant changes are included below.

Mobile ESS operations, consisting of lithium-ion batteries on trailers or skids are being deployed to locations to provide a temporary source of power. An operational permit is required for the mobile operations.

Section 1206.1 includes general requirements for all ESS. No significant changes were made to the Construction Document and Hazard Mitigation Analysis requirements.

Section 1206.1.5 - The 2018 code allowed certain variances be allowed based on large scale fire and fault condition testing, but the criteria for conducting such testing was undefined. The UL 9540A Test Method was specifically developed to cover this testing.

Section 1206.1.6 - This section was developed to address fire events involving lithium-ion battery systems, since lithium-ion battery fires have the potential to re-ignite hours or even days after initial extinguishment by the fire department, who cannot remain on scene indefinitely until the fire damaged ESS is safely removed from the premises. The fire remediation requirements, similar to fire watch requirements, make the owner responsible for sending mitigation personnel to the scene take over the remediation process.

Section 1206.2 covers commissioning, decommissioning, maintenance and testing requirements, which are important considerations for providing a safe, code compliant installation.

Section 1206.3 covers the ESS equipment itself, and much of these requirements are unchanged from the 2018 code. New section on repairs, retrofits and replacements were added to address practices to be followed when systems need to be upgraded or serviced.

Section 1206.3.8 allows code officials to regulate installations of repurposed electric vehicle batteries that are converted for ESS use in buildings.

Section 1206.4 includes requirements that need to be met by all ESS installations, and much of these are unchanged from the 2018 requirements. The Walk-in units section, with associated definition, is new and recognizes that ISO type

shipping containers are being used to house ESS in various outdoor and mobile applications.

Section 1206.5 describes ESS protection requirements that are only applicable for certain type of installations, such as indoor dedicated use ESS installations, outdoor ESS installations in remote locations, and rooftop installations. Section 1206.5 tells you how to provide a particular type of protection, and tables in Sections 1206.7 through 1206.10 tell you when this protection is required.

1206.5.2 The size and separation protection concept (formerly “arrays”) was introduced in the 2018 code. The term array was confusing and has been replaced. A maximum ESS unit size of 50 KWh previously only applied to unlisted ESS, but now all ESS are required to be listed due to the significant fire event that can be produced by 50 KWh of some ESS technologies.

1206.5.3 MAQs amounts are essentially the same as 2018 values. Due to introductions of facilities such as dedicated use ESS (utility size) requirements, and exemptions for increases based on large scale fire testing, it is no longer necessary to reference Group H-2 occupancies.

1206.5.4 Elevation requirements are similar to those in the 2018 IFC, but now restrict below grade installations except in underground vaults or when specifically approved by the code official. This is due to concerns raised by the fire service about responding to ESS fires in below grade locations.

1206.5.5 The previous smoke detection requirements have been modified to allow radiant energy-sensing fire detection as an option.

1206.5.6 The fire suppression requirements in the 2018 code only allowed NFPA 13 systems to be provided to protect ESS, but it was difficult or impossible to determine required design density. These requirements have been updated to specify a minimum 0.3 gpm/ft.² design density, with options for lower densities based on large scale fire testing per UL 9540A. Also an option for providing alternate fire suppression systems has been added, provided they have successfully passed UL 9540A fire testing.

1206.5.7 A maximum enclosure size for walk-in units, corresponding to the largest ISO type containers used for these installations, was established to provide differentiation between a walk-in unit and an inside installation.

1206.5.9 Separation from outdoor means of egress pathways leading to a public way were in the 2018 code.

Section 1206.6 includes electrochemical ESS technology specific protection, in a new table format. Table 1206.6 identifies which technologies need technology specific protection, which may include exhaust ventilation, spill control and neutralization, explosion control, safety caps and thermal runaway.

Section 1206.6.4 (explosion control) addresses a potentially significant hazard. Lithium-ion battery systems and other electrochemical ESS technologies have the potential to rapidly build up potentially explosive atmospheres in the battery or electrochemical ESS room or enclosure under thermal runaway and other conditions which could result in a catastrophic fire and or explosion. To protect against these hazards explosion control in accordance with IFC Section 911 is required for certain battery technologies.

Section 1206.7 covers indoor locations, and identifies two types of indoor installations, dedicated use installations (typical of utility grid related facilities) and non-dedicated use installations (typical of ESS in mixed use buildings or incidental use areas of occupancies). Protection for each installation is commensurate with the related risk and exposures.

Similarly Section 1206.8 covers two types of outdoor installations, remote outdoor installations (more than 100 feet from exposures, and installations near exposures (<100 ft.) more typical of an urban environment.

Section 1206.9 covers two special installations, rooftop ESS and open parking garage ESS.

Section 1206.10 covers two types of mobile ESS installations/operations, charging and storage of the mobile ESS at its home facility when it is not deployed to an event or facility, and deployment of the mobile ESS for temporary energy storage applications, such as providing power at an electric vehicle event. Mobile ESS charging and storage locations are treated the same as a stationary indoor or outdoor installation in accordance with Section 1206.7 or 1206.8, but can include temporary electrical and fire suppression system connections. This provides an acceptable level of protection based on the exposures at the facility, and prevents parties from using an ESS on wheels as a permanent ESS with less than effective protection.

Section 1206.10 also includes requirements for deploying mobile ESS to a facility or event for providing up to 30 days of temporary power (with some exceptions). An operational permit is required for each mobile ESS deployment.

The proposal also eliminated references to providing ESS in incidental use areas. Modern load leveling and peak shaving ESS applications make the 10% floor area limitations of incidental use areas impractical for anticipated installations. However the additional protection in this section, including equivalent Section 1206.7.5 fire-resistance rated separations, should effectively mitigate hazards with providing ESS on floor areas greater than 10% of the total floor area.

To summarize this proposal, developed by a large industry and code official work group, more effectively protects ESS installations based on knowledge gained since last code cycle. It provides protection customized for the types of installations that are being deployed today, instead of using the “one size fits all” type of protection in the 2018 code.

Cost Impact

The code change proposal will not increase or decrease the cost of construction .

Some of the requirements in this proposal have the potential to increase the cost of providing ESS installations. However some of the provisions in this proposal better address risks and owner/user needs in dedicated use (utility) buildings and outdoor remote installations, and will probably decrease the cost of those installations as compared to installations installed using the 2018 IFC requirements.

Analysis: A review of the standards proposed for inclusion in the code, UL 1974 -17, UL 9540A-17 and NFPA 76-16 , with regard to the ICC criteria for referenced standards (Section 3.6 of CP#28) will be posted on the ICC website on or before April 2, 2018.

Internal ID: 253

F204-18

IFC: 1206.2.1, 1206.2.1.1 (New), 80

Proponent: Michael O'Brian, Chair, representing FCAC (fcac@iccsafe.org)

2018 International Fire Code

Revise as follows:

1206.2.1 Permits. ~~Permits shall be obtained for the installation and operation of stationary storage battery systems in accordance with Section 105.7.2.ESS as follows:~~

1. Construction permits shall be obtained for stationary ESS installations and for mobile ESS charging and storage installations. Permits shall be obtained in accordance with Sections 105.7.7.
2. Operational permits shall be obtained for all stationary and mobile ESS installations and operations. Permits shall be obtained in accordance with Sections 105.6.14.

Add new text as follows:

1206.2.1.1 Communication utilities. Operational permits shall not be required for lead acid and nickel cadmium battery systems at facilities under the exclusive control of communications utilities that comply with NFPA 76 and operate at less than 50 VAC and 60 VDC.

Add new standard(s) follows:

NFPA

National Fire Protection Association
1 Batterymarch Park
Quincy MA 02169-7471

76-16:

Standard for the Fire Protection of Telecommunications Facilities

Reason:

Energy storage systems have a significant amount of ongoing maintenance, testing and servicing that requires supervision by the fire code official to ensure the system operates safely and doesn't present a hazard to occupants and emergency responders. This proposal is intended to supplement the significant FCAC rewrite of Section 1206. If both proposals are accepted the intent is that the wording in this proposal will replace Section 1206.1.2 of the other proposal and add a new section 1206.1.2.1.

This proposal is submitted by the ICC Fire Code Action Committee (FCAC). The FCAC was established by the ICC Board of Directors to pursue opportunities to improve and enhance assigned International Codes with regard to fire safety and hazardous materials in new and existing buildings and facilities and the protection of life and property in wildland urban interface areas. In 2017 the Fire-CAC has held 3 open meetings. In addition, there were numerous conference calls, Regional Work Group and Task Group meetings for the current code development cycle, which included members of the committees as well as any interested parties, to discuss and debate the proposed changes. Related documentation and reports are posted on the FCAC website at: <https://www.iccsafe.org/codes-tech-support/cs/fire-code-action-committee-fcac/>

Cost Impact

The code change proposal will not increase or decrease the cost of construction .

However it has the potential to increase local permit fees.

Analysis: A review of the standard proposed for inclusion in the code, NFPA 76 -16 with regard to the ICC criteria for referenced standards (Section 3.6 of CP#28) will be posted on the ICC website on or before April 2, 2018.

Internal ID: 264

F205-18

IFC: 1206.2.1

Proponent: Richard Kluge, representing Alliance for Telecommunications Industry Solutions
(richard.kluge@ericsson.com)

2018 International Fire Code

Revise as follows:

1206.2.1 Permits. Permits shall be obtained for the installation ~~and operation~~ of stationary storage battery systems in accordance with Section 105.7.2.

Reason:

The reference to a permit for the operation of a stationary storage battery system should be removed as such permits are not required by Section 105.7.2. Only construction permits are required for a stationary storage battery system per Section 105.7.2.

Cost Impact

The code change proposal will not increase or decrease the cost of construction .

The change is a clarification of the required permit type and will not change code implementation or cost of construction.

Internal ID: 1875

F206-18

IFC: 1206.2.3.2, 1206.2.8.3, 1206.2.11.1, Chapter 80

Proponent: Charles Foster, self, representing Energy Storage Association (chuck@crfenergy.com)

2018 International Fire Code

Revise as follows:

1206.2.3.2 Analysis approval. The *fire code official* is authorized to approve the hazardous mitigation analysis provided that the hazard mitigation analysis demonstrates all of the following:

1. Fires or explosions will be contained within unoccupied battery storage rooms for the minimum duration of the fire-resistance-rated walls identified in Table 509.1 of the International Building Code.
2. Fires ~~and explosions~~ in battery cabinets in occupied work centers will be detected in time to allow occupants within the room to evacuate safely.
3. Toxic and highly toxic gases released during fires and other fault conditions shall not reach concentrations in excess of Immediately Dangerous to Life or Health (IDLH) levels in the building or adjacent means of egress routes during the time deemed necessary to evacuate from that area.
4. Flammable gases released from batteries during charging, discharging and normal operation shall not exceed 25 percent of their lower flammability limit (LFL).
5. Flammable gases released from batteries during fire, overcharging and other abnormal conditions shall not create an explosion hazard that will injure occupants or emergency responders.

1206.2.8.3 Stationary battery arrays. Storage batteries, prepackaged stationary storage battery systems and preengineered stationary storage battery systems shall be segregated into stationary battery arrays not exceeding 50 kWh (180 megajoules) each. Each stationary battery array shall be spaced not less than 3 feet (914 mm) from other stationary battery arrays and from walls in the storage room or area. The storage arrangements shall comply with Chapter 10.

Exceptions:

1. Lead acid and nickel cadmium storage battery arrays.
2. Listed preengineered stationary storage battery systems and prepackaged stationary storage battery systems shall not exceed 250 kWh (900 megajoules) each.
3. ~~The fire code official is authorized to approve listed, preengineered and prepackaged battery arrays with larger capacities larger maximum battery capacities and/or smaller battery array spacing if based on the results of large scale fire testing performed in accordance with UL 9540A, and fault condition testing conducted or witnessed and reported by an approved testing laboratory is provided showing that a fire involving one array will not propagate to an adjacent array, and be contained within the room for a duration equal to the fire resistance rating of the room separation specified in Table 509 of the International Building Code.~~

1206.2.11.1 Fire-extinguishing systems. Rooms containing stationary storage battery systems shall be equipped with an *automatic sprinkler system* installed in accordance with Section 903.3.1.1. Commodity classifications for specific technologies of storage batteries shall be in accordance with Chapter 5 of NFPA 13. If the storage battery types are not addressed in Chapter 5 of NFPA 13, the *fire code official* is authorized to approve the fire-extinguishing system based on full-scale fire and fault condition testing conducted or witnessed and reported by an *approved* laboratory.

Exception:

1. Spaces or areas containing stationary storage battery systems used exclusively for telecommunications equipment in accordance with Section 903.2.
2. Unoccupied, non-combustible containers located outdoors, meeting the clearances found in Section 1206.2.8.7.1, and housing only ESS equipment.

UL

9540A-17:

Underwriters Laboratories LLC
333 Pfingsten Road
Northbrook IL 60062

UL Standard for Safety Test Method for Evaluating Thermal Runaway Fire Propagation in Battery Energy Storage Systems

Reason:

This proposal addresses 3 sections as described below.

1. It removes the words "and explosion" in section 1206.2.3.2(2). This provision deals with early detection to allow for evacuation and seems impossible for an explosion.
2. It restates the existing exception found in section 1206.2.8.3(3) to specifically identify the reference to UL 9540A.
3. It adds to the exception found at 1206.2.11.1 to include non-combustible containers located outdoors and meeting the clearances found at housing only ESS equipment. Since the non-combustible ESS container is unoccupied, outdoors, and away from combustibles, sprinkling would not have a significant impact on life safety or minimizing property damage.

Cost Impact

The code change proposal will not increase or decrease the cost of construction .

This proposal removes the requirement to sprinkle unoccupied, non-combustible buildings located outside away combustibles and reduces the cost of construction.

Internal ID: 2090

F207-18

IFC: 1206.2.10.4

Proponent: Jonathan Roberts, UL LLC, representing UL LLC (jonathan.roberts@ul.com)

2018 International Fire Code

Revise as follows:

1206.2.10.4 Battery chargers. Battery chargers shall be compatible with the battery chemistry and the manufacturer's electrical ratings and charging specifications. Battery chargers shall be listed and labeled in accordance with UL ~~1564~~1741 or provided as part of a listed preengineered or prepackaged stationary storage battery system.

Reason:

UL 1741 is the correct standard to be used in listing battery chargers. The scope of UL 1741 includes inverters, converters, charge controllers, and interconnection system equipment (ISE) intended for use in stand-alone (not grid-connected) or utility-interactive (grid-connected) power systems.

UL 1564 covers battery chargers intended for use with industrial storage batteries, which provide power for material-handling trucks, tractors, personnel carriers, and similar motive equipment.

Cost Impact

The code change proposal will not increase or decrease the cost of construction .

Manufacturers already have their battery chargers used with energy storage systems properly listed for this use in accordance with UL 1741.

Internal ID: 230

F208-18

IFC: 1206.2.11.2

Proponent: Richard Kluge, Ericsson Inc., representing Alliance for Telecommunications Industry Solutions (richard.kluge@ericsson.com)

2018 International Fire Code

Revise as follows:

1206.2.11.2 Smoke detection system. An *approved automatic smoke detection system* shall be installed in rooms containing *stationary storage battery systems* in accordance with Section 907.2.

Exception: Normally unoccupied, stand-alone telecommunications structures with a gross floor area of less than 1500 ft² (140 m²) shall not be required to have an *approved automatic smoke detection system*.

Reason:

There is little value to installing a fire or smoke detection system in a small normally unoccupied, stand-alone telecommunications structure. These facilities are categorized as Use Group U facilities under the IBC. There is no intent that these structures be occupied except for servicing and maintaining the equipment they house. The recommended text is consistent with NFPA 1 chapter 52 on Energy Storage Systems as well as pending changes to NFPA 76 on Telecommunications facilities.

Cost Impact

The code change proposal will decrease the cost of construction .

Not requiring detection in these sites will decrease the cost of code compliance in initial construction, as well as ongoing operations, testing, maintenance.

Internal ID: 1946

F209-18

IFC: 1206.2.11.5

Proponent: Jeffrey Betz, AT&T Corporation, representing AT&T Corporation (jbetz@att.com)

2018 International Fire Code

Revise as follows:

1206.2.11.5 Spill control and neutralization. Where required by Section 1206.2.12, approved methods and materials shall be provided for the control and neutralization of spills of electrolyte or other hazardous materials in areas containing stationary storage batteries as follows:

1. For batteries with free-flowing electrolyte, ~~the a~~ method and materials shall be capable of ~~neutralizing of~~:
 - 1.1. Providing spill control to prevent the flow of electrolyte to adjoining areas when rooms or areas are used for the storage of free-flowing electrolyte in individual vessels having a capacity of more than 55 gallons (208 L), or in which the aggregate capacity of multiple vessels exceeds 1,000 gallons (3785 L)
 - 1.2. Neutralizing a spill of the total capacity from the largest individual cell or block to a pH between 5.0 and 9.0.
2. For batteries with immobilized electrolyte, the method and material shall be capable of neutralizing a spill of 3.0 percent of the capacity of the largest cell or block in the room to a pH between 5.0 and 9.0.

Reason:

This proposal incorporates and clarifies the code industry's basic quantity requirements for spill control. It further provides the specific requirements of this chapter (12 formerly Section 608) related to vessel and aggregate thresholds currently addressed in the 2015 IFC Section 608 Commentary (2018 IFC 1206.2.11.5 Spill containment and neutralization) and 2015 IFC Code and Commentary Chapter 50 Hazardous Materials Section 5004.2.1 Spill control for hazardous materials liquids. 2015 IFC Commentary - Section 608.5 Batteries that contain a free-flowing liquid electrolyte pose the same containment problems as any other corrosive liquid hazardous material, but the containment and neutralization provisions in this section are performance based and neither specifically require spill control in the form of containment nor a specific method of neutralization. The quantity of neutralization material required to be available would be greater for these less-viscous electrolytes, however, because of their mobility and the rapidity with which they can spread and the potential scope of the spread. See the commentary to Section 5004.2.1 for further discussion of spill control strategies. The exception recognizes the reduced spill control hazard of sealed batteries that contain a higher-viscosity electrolyte. 2015 IFC Commentary - Chapter 50 Hazardous Materials 5004.2.1 Spill control for hazardous material liquids The requirement for spill control in a room or area is based on two items. The first is that the storage container(s) have a capacity of more than 55 gallons (208 L). The second is that the aggregate capacity of multiple vessels be more than 1,000 gallons (3785 L). The area, once determined to require spill control, must be protected so that the containment area will handle the release from the largest container in the area.

Cost Impact

The code change proposal will not increase or decrease the cost of construction .

No additional cost impact, as this clarifies intent of current code.

Internal ID: 2241

F210-18

IFC: 1206.1.1(New),1206.6.4 (New), Chapter 80

Proponent: Robert Davidson, Davidson Code Concepts, LLC, representing Tesla, USA
(rjd@davidsoncodeconcepts.com)

2018 International Fire Code

Add new text as follows:

1206.4 Exterior wall installations. ESS shall be permitted to be installed outdoors on exterior walls of buildings when all of the following conditions are met:

1. The maximum energy capacity of individual ESS units shall not exceed 20 KWh.
2. The ESS shall comply with applicable requirements in Sections 1206.
3. The ESS shall be installed in accordance with the manufacturer's instructions and their listing.
4. Individual ESS units shall be separated from each other by at least three feet (914 mm).
5. The ESS shall be separated from doors, windows, operable openings into buildings, or HVAC inlets by at least five feet (1524 mm).

Exception: Where approved smaller separation distances in items 4 and 5 shall be permitted based on large scale fire testing complying with Section 1206.1.1.

1206.1.1 Large scale test. Where required elsewhere in Section 1206, large scale fire testing shall be conducted on a representative ESS in accordance with UL 9540A. The testing shall be conducted or witnessed and reported by an approved testing laboratory and show that a fire involving one ESS will not propagate to an adjacent ESS, and where installed within buildings, enclosed areas and walk-in units will be contained within the room, enclosed area or walk-in unit for a duration equal to the fire resistance rating of the room separation specified in Section 1206.2.8.2. The test report shall be provided to the fire code official for review and approval in accordance with Section 104.7.2.

UL

Underwriters Laboratories LLC
333 Pfingsten Road
Northbrook IL 60062

9540A-17:

Standard for Safety Test Method for Evaluating Thermal Runaway Fire Propagation in Battery Energy Storage Systems

Reason:

This proposal is intended to complement the comprehensive FCAC rewrite of Section 1206, and fit in with the proposed numbering system. However since it is a separate proposal it has been written to fit with the numbering in current Section 1206. It is the intent that if the proposal which rewrites Section 1206 should pass this section should be numbered 1206.8.5. Also new section 1206.1.1 is to be consistent with Section 1206.1.5 proposed in the rewrite of Section 1206.

The new section provides requirements for wall mounted ESS that are being sold and installed on an increasing basis for those users not requiring the larger systems. Without this proposal the code will not allow installation of small ESS Units on the outside walls of buildings.

Cost Impact

The code change proposal will decrease the cost of construction .

The proposal actually provides a cost effective alternative for providing ESS in facilities with limited indoor and outdoor areas for installation and lower energy needs in comparison to current code provisions.

Analysis: A review of the standard proposed for inclusion in the code, UL 9540A-17, with regard to the ICC criteria for referenced standards (Section 3.6 of CP#28) will be posted on the ICC website on or before April 2, 2018.

Internal ID: 1532

F211-18

IFC: 1206.1, 1206.11 (New), 1206.11.1 (New), 1206.4 (New), Chapter 80

Proponent: Michael O'Brian (FCAC@iccsafe.org)

2018 International Fire Code

CHAPTER 12 ENERGY SYSTEMS

SECTION 1206 ELECTRICAL ENERGY STORAGE SYSTEMS

Revise as follows:

1206.1 Scope. The provisions in this section are applicable to energy storage systems designed to provide electrical power to a building or facility. These systems are used to provide standby or emergency power, an uninterruptable power supply, load shedding, load sharing or similar capabilities.

Exception: ESS in Group R-3 and R-4 occupancies shall comply with Section 1206.11.

1206.1.1 Large scale test. Where required elsewhere in Section 1206, large scale fire testing shall be conducted on a representative ESS in accordance with UL 9540A. The testing shall be conducted or witnessed and reported by an approved testing laboratory and show that a fire involving one ESS will not propagate to an adjacent ESS, and where installed within buildings, enclosed areas and walk-in units will be contained within the room, enclosed area or walk-in unit for a duration equal to the fire resistance rating of the room separation specified in Section 1206.2.8.2. The test report shall be provided to the fire code official for review and approval in accordance with Section 104.7.2

Add new text as follows:

1206.4 Group R-3 and R-4 occupancies ESS. ESS installed for Group R-3 or Group R-4 occupancies shall comply with the provisions of sections 1206.4.1 through 1206.4.9.

Exception: The use of an electric powered vehicle to power the dwelling while parked shall comply with Section 1206.4.10.

1206.4.1 Equipment listings. ESS shall be listed and labeled for residential use in accordance with UL 9540.

Exceptions:

1. Where approved, repurposed unlisted battery systems from electric vehicles are allowed to be installed outdoors or in detached dedicated cabinets located not less than 5 feet (1524 mm) from exterior walls, property lines and public ways.
2. ESS less than 1 kWh (3.6 megajoules).

1206.4.2 Installation. ESS shall be installed in accordance with the manufacturer's instructions and their listing.

1206.4.2.1 Spacing. Individual units shall be separated from each other by at least three feet of spacing unless smaller separation distances are documented to be adequate based on large scale fire testing complying with Section 1206.1.1.

1206.4.3 Location. ESS shall only be installed in the following locations:

1. Detached garages and detached accessory structures.
2. Attached garages separated from the dwelling unit living space and sleeping units in accordance with Section 406.3.2 of the International Building Code.
3. Outdoors on exterior walls located a minimum 3 ft. from doors and windows.
4. Utility closets and storage or utility spaces within dwelling units and sleeping units.

1206.4.4 Energy ratings. Individual ESS units shall have a maximum rating of 20 KWh. The aggregate rating structure shall not exceed:

1. 40 KWh within utility closets and storage or utility spaces.
2. 80 KWh in attached or detached garages and detached accessory structures.
3. 80 kWh on exterior walls.
4. 80 kWh outdoors on the ground.

1206.4.5 Electrical installation. ESS shall be installed in accordance with NFPA 70. Inverters shall be listed and labeled in accordance with UL 1741 or provided as part of the UL 9540 listing. Systems connected to the utility grid shall use inverters listed for utility interaction.

1206.4.6 Fire detection. Rooms and areas within dwellings units, sleeping units and attached garages in which ESS are installed shall be protected by smoke alarms in accordance with Section 907.2.10. A heat detector listed and interconnected to the smoke alarms shall be installed in locations within dwelling units, sleeping units and attached garages where smoke alarms cannot be installed based on their listing.

1206.4.7 Protection from impact. Stationary storage battery systems installed in a location subject to vehicle damage shall be protected by approved barriers. Appliances in garages shall also be installed in accordance with Section 304.3 of the International Mechanical Code.

1206.4.8 Ventilation. Indoor installations of ESS that include batteries that produce hydrogen or other flammable gases during charging shall be provided with ventilation in accordance with Section 1206.2.11.3.

1206.4.9 Toxic and highly toxic gas. ESS that have the potential to release toxic or highly toxic gas during charging, discharging and normal use conditions shall not be installed within Group R-3 or R-4 occupancies.

1206.4.10 Electric vehicle use. The use of owner or occupant's electric powered vehicle to power a dwelling unit or sleeping unit while parked in an attached or detached garage or outside shall comply with the vehicle manufacturer's instructions and NFPA 70.

CHAPTER 2 DEFINITIONS

SECTION 202 GENERAL DEFINITIONS

[IRC] LIVING SPACE.

Space within a dwelling unit utilized for living, sleeping, eating, cooking, bathing, washing and sanitation purposes.

UL

Underwriters Laboratories LLC
333 Pfingsten Road
Northbrook IL 60062

9540A-17:

Standard for Safety Test Method for Evaluating Thermal Runaway Fire Propagation in Battery Energy Storage Systems

Reason:

This proposal includes requirements ESS installations in Group R-3 and R-4 occupancies. Currently the commercial level of requirements found in the IFC would be applicable. The intent is to provide a level of protection that is equivalent to ESS requirements in the 2018 IRC. However, additional detail is being provided to enhance safety.

Generally the proposal is based upon the 2018 numbering but if the ESS rewrite should also pass the intent is that this section be numbered 1206.11. Note that the intent of the reference in Section 1206.11.1.2 to new section 1206.1.1 is to be consistent with Section 1206.1.5. in the ESS rewrite proposal.

A definition for dwelling unit living space from the IRC is being duplicated in this Code.

An exception is being provided to the scope of Section 1206 to clarify that R-3 and R-4 ESS are only required to comply with Section 1206.11, and not the other sections of 1206.

Section 1206.4.3 - This section provides the locations where ESS can be installed.

Section 1206.4.4 - The 2018 IRC allowed ESS to be installed in closets, storage and utility rooms in dwelling units with no additional protection. This proposal allows ESS to be installed in those rooms and areas, but requires them to comply with the same fire-resistance rated separation as required between an attached garage and the dwelling unit in IRC Section R302.6.

Section 1206.4.5 provides limits on the maximum energy provided for a single ESS unit, and the aggregate. Units up to 20 kWh are commercially available and limiting the installation to an aggregate 40 kWh limits the potential heat release rate to an acceptable level within the dwelling unit. Allowing 80 kWh in attached garages, detached structures and outdoors allows additional ESS to be provided to help meet the energy needs of the residence. The increased aggregate amount recognizes that electric vehicles with 85 kWh to 10 kWh are already parked in attached garages and adjacent to dwellings.

ESS installations in excess of 80 kWh are required to comply with all applicable IFC requirements. It also prevents parties from installing a commercial/grid type ESS installations on residential property without meeting applicable safety requirements.

Section 1206.4.6 requires smoke detection to be provided in rooms or garages in which ESS are located, in order to provide early warning in case of an incident involving the ESS. Since smoke alarms are not listed for use in garages or unconditioned spaces, an interconnected heat alarm can be used to provide the early warning.

Note that the intent of the reference in Section 1206.4.1.2 to a new section 1206.1.1 is to be consistent with Section 1206.1.5. in the ESS rewrite proposal. The language is the same and should be correlated if both proposals should pass.

This proposal is submitted by the ICC Fire Code Action Committee (FCAC). The FCAC was established by the ICC Board of Directors to pursue opportunities to improve and enhance assigned International Codes with regard to fire safety and hazardous materials in new and existing buildings and facilities and the protection of life and property in wildland urban interface areas. In 2017 the Fire-CAC has held 3 open meetings. In addition, there were numerous conference calls, Regional Work Group and Task Group meetings for the current code development cycle, which included members of the committees as well as any interested parties, to discuss and debate the proposed changes. Related documentation and reports are posted on the FCAC website at: <https://www.iccsafe.org/codes-tech-support/cs/fire-code-action-committee-fcac/>

Cost Impact

The code change proposal will decrease the cost of construction .

When applying IFC requirements to Group R-3 and R-4 installations, this proposal will decrease the cost of construction since it exempts many of the requirements in Section 1206.1 through 1206.9.

Internal ID: 308

F212-18

IFC: Chapter 22, 202 (New)

Proponent: Ellie Klausbruckner, representing Klausbruckner & Associates, Inc. (ek@klausbruckner.com); Kevin Scott, representing KH Scott & Associates LLC (khscottassoc@gmail.com)

2018 International Fire Code

Revise as follows:

CHAPTER 22 COMBUSTIBLE DUST-PRODUCING OPERATIONS

SECTION 2201 GENERAL

Delete without substitution:

~~**2201.1 Scope.** The equipment, processes and operations involving dust explosion hazards shall comply with the provisions of this code and NFPA 652.~~

~~**2201.2 Permits.** Permits shall be required for *combustible dust* producing operations as set forth in Section 105.6.~~

SECTION 2202 DEFINITION

~~**2202.1 Definition.** The following term is defined in Chapter 2:~~

~~**COMBUSTIBLE DUST.**~~

SECTION 2203 PRECAUTIONS

~~**2203.1 Owner responsibility.** The owner or operator of a facility with operations that manufacture, process, blend, convey, repackage, generate or handle potentially combustible dust or combustible particulate solids shall be responsible for compliance with the provisions of this code and NFPA 652.652.~~

~~**2203.2 Dust hazard analysis (DHA).** The requirements of NFPA 652 apply to all new and existing facilities and operations with combustible dust hazard. Existing facilities shall have a dust hazard analysis (DHA) completed in accordance with Section 7.1.2 of NFPA 652.652.
The fire code official shall be authorized to order a dust hazard analysis to occur sooner if a combustible dust hazard has been identified in a facility that has not previously performed an analysis.~~

~~**2203.3 Sources of ignition.** Smoking, the use of heating or other devices employing an open flame, or the use of spark-producing equipment is prohibited in areas where *combustible dust* is generated, stored, manufactured, processed or handled.~~

~~**2203.4 Housekeeping.** Accumulation of *combustible dust* shall be kept to a minimum in the interior of buildings. Accumulated *combustible dust* shall be collected by vacuum cleaning or other means that will not place *combustible dust* into suspension in air. Forced air or similar methods shall not be used to remove dust from surfaces.~~

SECTION 2204 ADDITIONAL REQUIREMENTS

~~**2204.1 Specific hazards standards.** The industry or commodity specific codes and standards listed in Table 2204.1 shall be complied with based on the identification and evaluation of the specific fire and deflagration hazards that exist at a facility.~~

**TABLE 2204.1
SPECIFIC HAZARDS STANDARDS**

STANDARD	SUBJECT
NFPA 61	Standard for the Prevention of Fires and Dust Explosions in Agricultural and Food Processing Facilities
NFPA 69	Standard on Explosion Prevention Systems
NFPA 70	National Electrical Code
NFPA 85	Boiler and Combustion System Hazards Code
NFPA 120	Standard for Fire Prevention and Control in Coal Mines
NFPA 484	Standard for Combustible Metals
NFPA 654	Standard for Prevention of Fire and Dust Explosions from the Manufacturing, Processing and Handling of Combustible Particulate Solids
NFPA 655	Standard for the Prevention of Sulfur Fires and Explosions
NFPA 664	Standard for the Prevention of Fires and Explosions in Wood Processing and Woodworking Facilities

Add new text as follows:

2201.1 Scope. The equipment, processes and operations involving dust explosion hazards and use or handling of combustible dust shall comply with the provisions of this chapter

Exceptions:

1. In an unsprinklered building, dust production or use, including use-open and use-closed systems, where the quantity does not exceed 5 pounds (2.3 kg) or 0.7 cu ft. (0.019822 m³)
2. In a building equipped throughout with an automatic sprinkler system in accordance with Section 903.3.1.1, dust production or use, including use-open and use-closed systems, where the quantity does not exceed 10 pounds (4.5 kg) or 1.4 cu ft. (0.039644 m³)

3. Storage and use of consumer materials in Group B or R occupancies.
4. Storage and use of commercially packaged materials in Group M occupancies.
5. Materials displayed in original packaging in Group M occupancies and intended as building materials or for personal or household use.
6. Storage of sealed containers of combustible dust at facilities not associated with an operation that uses, handles or generates combustible dust.
7. Materials stored or used in farm buildings or similar occupancies intended for on-premises agricultural purposes.

2201.2 Permits. Permits shall be required for combustible dust-producing operations as set forth in Section 105.6.

2202 DEFINITIONS

2202.1 Definitions. The following terms are defined in Chapter 2:

Dust Collection System

Combustible Dust

2203 DUST EXPLOSION PREVENTION

2203.1 Critical Depth Layer.

The maximum dust layer on all surfaces, including but not limited to walls, ceilings, beams, equipment, furniture, pipes and ducts, shall not exceed the Critical Depth Layer specified in Table 2203.1. The critical depth layer depth is permitted to be adjusted for explosion hazard further evaluated in accordance with one of the following:

1. Section 6.1.1.3 of NFPA 654.
2. Section 4.2.2 of NFPA 664 for wood flour.

Accumulated combustible dust shall be collected by one of the methods listed in 2203.5.

Table 2203.1
Critical Depth Layer

<u>Type of Dust</u>	<u>Critical Depth Layer (Inches)</u>
<u>Wood Flour</u>	<u>1/8</u>
<u>All Other Dusts</u>	<u>1/32</u>

For SI: 1 inch = 25.4 mm

2203.2 Dust Producing and Dust Handling Equipment. Dust producing equipment and dust handling equipment, including but not limited to vacuums, dust collection systems, dryers, mixers, blenders, separators, conveyors, storage containers, silos or other similar devices shall be listed and shall be maintained in accordance with the manufacturer's recommended standards.

2203.2.1 Signages and Markings. Signages and markings shall be provided in accordance with Section 2203.2.1.1 through 2203.2.1.3.

2203.2.1.1 Deflagration Vent Discharge Area Markings. Where dust collection systems and other equipment, systems, or systems components are provided with deflagration vents, the area within the deflagration vent's discharge area shall be marked in an approved manner.

2203.2.1.2 Caution Signs.

Signs shall be posted near the dust containing equipment with deflagration vents that reads as follows:

CAUTION: THIS EQUIPMENT CAN CONTAIN EXPLOSIVE DUST.

KEEP OUTSIDE THE MARKED AREA WHILE EQUIPMENT IS OPERATING.

2203.2.1.3 Warning Signs. Where dust collection systems and other equipment, systems, or systems components are provided with deflagration vents, vent closures shall be clearly marked as follows:

WARNING: EXPLOSION RELIEF DEVICE. STAY CLEAR.

2203.3 Dust Collection and Conveying Systems. Dust collection and conveying systems shall be in accordance with Sections 2203.3.1 through 2203.3.3.

2203.3.1 Dust Collection Systems. Dust collection systems shall be designed to collect dust emissions from dust producing equipment at the point of generation. Dust collection systems shall be in accordance with Section 511 of the International Mechanical Code.

Exception: Closed systems using listed equipment and designed in accordance with manufacturer's recommendations and specifications, where cleanouts are provided in accordance with Section 2203.3.3.

Heating, ventilation, and air conditioning (HVAC) systems shall not be used as the means to collect dusts from localized sources.

2203.3.1.1 Location. Dust collectors shall be located outside of buildings.

Exceptions:

1. Dust collectors inside of buildings complying with Section 511 of the International Mechanical Code.
2. Wet-type dust collectors when specifically listed for the type of dust conveyed shall be permitted inside of buildings where in accordance with the manufacturer's instructions and specifications.
3. Dust collectors designed to specific NFPA standards listed in Table 2204.1 for the specific type of dust conveyed.

2203.3.1.2 Minimum Conveying Velocities. The minimum velocities within ducts used as part of the dust collection system shall be in accordance with Table 2203.3.1.2.

Table 2203.3.1.2
Minimum Conveying Velocities

Type of Product	Feet Per Minute
Fine light dust, such as cotton, lint, and wood flour (100 mesh and under)	2000 (10 m/s)
Dry dust such as fine rubber molding powder	2500 (13 m/s)
Average dust such as sawdust, grinding dust, coal dust	3500 (18 m/s)
Heavy dust such as metal turnings, including aluminum and magnesium powder	4000 (20 m/s)

2203.3.2 Plastic Ducts and Conveying Systems. Plastic, fiberglass, other nonconductive ducts, duct liners or pipes shall not be used as part of ducts and conveying systems. Ductwork utilizing a combustible lining shall be permitted only in high impact areas and where approved. Flexible hose shall be permitted if designed and installed in accordance with the following requirements:

1. Manufactured of static dissipative construction.
2. Used only for connections and isolation purposes.
3. Limited to 18 inches (457 mm) in length.
4. Properly grounded.

2203.3.3 Cleanouts. Openings shall be provided in enclosed equipment and conveyors to allow access to all parts of the equipment and conveyors to permit inspection, cleaning, maintenance, and the effective use of portable extinguishers or hose streams. Cleanouts for ducts used as part of the dust collection system shall be in accordance with the International Mechanical Code.

2203.4 Sources of Ignition. Sources of Ignition shall be controlled in accordance with Sections 2203.4.1 through 2203.4.9.5.

2203.4.1 Classified Electrical. Classified electrical shall be in accordance with NFPA 70. Electrical motors and electrical components of the equipment shall not be installed in the dust laden air stream unless listed for Class II, Division 1 locations.

2203.4.2 Static Electricity. Bonding and grounding is required to minimize accumulation of static electric charge in the following locations:

1. Dust producing equipment
2. Dust collection system.
3. Pneumatic dust conveying systems conveying combustible dust from one location to another, combustible dust conveyors, piping and conductive components. Conveying systems include transport modes such as railcars, hopper cars, boxcars, tank cars and trucks into which or from which commodities or products are pneumatically conveyed.

4. Conveying systems using metallic piping.

2203.4.3 Hot Works. Hot work and similar spark producing operations shall not be conducted in or adjacent to combustible dust producing areas unless precautions have been taken to provide safety. Hot work shall be permitted only in safe, designated areas in accordance with Chapter 35. Hot work is prohibited on equipment that is operating.

2203.4.3.1 Signs. Conspicuous signs with the following warning shall be posted in the vicinity of combustible dust producing areas or in the vicinity of combustible dust use:

NO WELDING. THE USE OF WELDING OR CUTTING EQUIPMENT IN OR NEAR THIS AREA IS DANGEROUS BECAUSE OF FIRE AND EXPLOSION HAZARDS. WELDING AND CUTTING SHALL BE DONE ONLY UNDER THE SUPERVISION OF THE PERSON IN CHARGE.

2203.4.4 Hot Surfaces and Hot Equipment. In areas where a dust explosion hazard or dust flash fire hazard exists, the temperature of external surfaces, shall be maintained below 80 percent (in degrees Celsius) of the lower of the dust surface ignition temperature or the dust-cloud ignition temperature for worst-case dusts. External surfaces shall include but not limited to:

1. Compressors.
2. Steam, water or process piping.
3. Ducts.
4. Conveyors.
5. Process equipment.

Where steam pipes or hot surfaces occur in dust producing or dust handling areas, accumulation of dust on the surfaces shall be minimized by an approved method.

Exception: Drying apparatus listed for the intended use and installed in accordance with the manufacturer's instructions.

2203.4.5 Powered Industrial Trucks. Powered industrial trucks used in electrically classified areas shall be listed for such use.

2203.4.6 Smoking Prohibited. Smoking shall be prohibited in or adjacent to dust producing or dust handling areas. "No Smoking" signs complying with Section 310 shall be conspicuously posted in such areas. Smoking shall be permitted only in designated areas.

2203.4.7 Spark Producing Devices. Spark-producing devices shall not be located within 20 feet (6096 mm) of areas requiring classified electrical unless separated by a permanent partition.

2203.4.8 Self-heating materials. Materials in silos and other large storage piles of particulates prone to self-heating shall be in accordance with Section 8.5.11 of NFPA 652.

2203.4.9 Open Flames and Fuel Fired Equipment. Open flames and fuel fired equipment shall be in accordance with Section 2203.4.9.1 through 2203.4.9.5.

2203.4.9.1 Release or Airborne Combustible Dust. Production, maintenance or repair activities that have the potential to release or force combustible dust to become airborne shall not be conducted within 35 feet (11 m) of an open flame or pilot flame.

2203.4.9.2 Space Heaters. Fuel-fired space heaters drawing local ambient air shall not be located within electrically classified areas. Space heating appliances in dust producing or dust handling areas shall be located where not subject to accumulation of deposits of combustible dust.

2203.4.9.3 Equipment Listing. Fuel-fired process equipment shall be listed for its intended use and shall be operated and maintained in accordance with the manufacturer's instructions.

2203.4.9.4 Inspection and Preventative Maintenance. Inspection and maintenance of fuel-fired process equipment shall include verification that significant combustible dust accumulations do not exist within or around the equipment.

2203.4.9.5 Sources of Combustion Air. In Class II electrically classified locations, heating units shall be provided with a source of combustion air ducted directly from the building exterior or from an unclassified location.

2203.5 Housekeeping. Accumulation of combustible dust on surfaces inside buildings shall be maintained below the critical depth layer in Section 2203.1. Pressurized air or similar methods shall not be used to remove dust from surfaces. Accumulated combustible dust shall be collected by one of the following methods:

1. Portable vacuum cleaners listed for use in Class II, Group G, Division 1 atmospheres as defined in NFPA 70.
2. Dust collection systems.
3. Other approved means that will not place combustible dust into suspension in air.

2203.6 Standard Operational Procedures. Dust producing equipment and all associated equipment including dust collection equipment shall be maintained in accordance with the manufacturer's instructions and specifications and applicable codes. The inspection, testing and maintenance program shall include the following, as applicable:

1. Fire and explosion protection and prevention equipment, as applicable, in accordance with the applicable NFPA standards.
2. Dust control equipment.
3. Control of potential ignition sources.
4. Electrical, process and mechanical equipment, including applicable process interlocks.
5. Lubrication of bearings for dust collection, dust handling and dust producing equipment.
6. Additional maintenance in accordance with the manufacturer's instructions and specifications for dust collection, dust handling and dust producing equipment.

Records shall be kept of maintenance and repairs performed. The standard operating procedures shall be submitted to the fire code official for review and approval. The written standard operating procedures shall be signed by the person responsible for facility operations.

2203.7 Emergency Response Plan. A written emergency response plan shall be developed for preventing, preparing for and responding to work-related emergencies including but not limited to fire and explosion. The following information shall be developed into the plan:

1. Identification of dust hazards.
2. Identification and location of all utilities to affected areas.
3. Site plans or floor plans locating utility shut-off controls including water, gas and power.
4. Identify the potential for explosion.
5. Identify the location of fire extinguishing equipment compatible with the hazards present.
6. Any additional information required by the fire code official.

2203.8 Training. The plans and procedures required in Sections 2203.5, 2203.6 and 2203.7 shall be approved by the fire code official, The plans and procedures shall be reviewed annually and updated as required by process changes. Initial and annual refresher training shall be provided to employees who are involved in operating, maintaining and supervising facilities that handle combustible dust. Initial and annual refresher training shall include:

1. Workplace hazards.
2. General orientation, plant diagrams and plant safety rules.
3. Process description or flowchart.
4. Equipment operation, safe startup and shutdown, and response to hazard conditions or an incident.
5. The location and use of all related fire and explosion protection and prevention systems.
6. Equipment maintenance requirements and practices, including visual inspections of conveyors and ducts.
7. Housekeeping requirements, including the maintenance of the critical depth layer in Section 2203.1.
8. Emergency response plans as required in Section 2203.7.

The employer shall maintain records of initial and annually training and review.

2204 DUST EXPLOSION SCREENING TESTS

2204.1 Combustibility and Explosivity Tests. Where combustibility or explosivity screening tests are required to analyze the combustible dust as part of compliance with Section 414.1.3 of the International Building Code and Section 104.7 of the this code, it shall be in accordance with Section 5.4 of NFPA 652.

2204.2 Samples. Representative samples for the screening test shall be obtained in accordance with Section 5.5 of NFPA 652.

2205 STANDARDS

2205.1 Specific Hazards Standards. The fire code official is authorized to enforce additional industry or material specific provisions of the codes and standards listed in Table 2205.1 as applicable to prevent and control dust explosions.

**Table 2205.1
Explosion Protection Standards**

<u>Standard</u>	<u>Subject</u>
<u>NFPA 61</u>	<u>Standard for the Prevention of Fires and Dust Explosions in Agricultural and Food Processing Facilities</u>
<u>NFPA 69</u>	<u>Standard on Explosion Prevention Systems</u>
<u>NFPA 70</u>	<u>National Electrical Code</u>
<u>NFPA 77</u>	<u>Recommended Practice on Static Electricity</u>
<u>NFPA 85</u>	<u>Boiler and Combustion System Hazards Code</u>
<u>NFPA 120</u>	<u>Standard for Fire Prevention and Control in Coal Mines</u>
<u>NFPA 484</u>	<u>Standard for Combustible Metals</u>
<u>NFPA 652</u>	<u>Standard on the Fundamentals of Combustible Dust</u>
<u>NFPA 654</u>	<u>Standard for Prevention of Fire and Dust Explosions from the Manufacturing, Processing and Handling of Combustible Particulate Solids</u>
<u>NFPA 655</u>	<u>Standard for the Prevention of Sulfur Fires and Explosions</u>
<u>NFPA 664</u>	<u>Standard for the Prevention of Fires and Explosions in Wood Processing and Woodworking Facilities</u>

2205.1.1 Dust Hazard Analysis. If a dust hazard analysis (DHA) is required by the fire code official to new or existing facilities and operations, it shall be in accordance with NFPA 652. The DHA for existing facilities shall be in accordance with Section 7.1.2 of NFPA 652.

DUST COLLECTION SYSTEM. A combination of equipment designed to contain, capture and collect airborne combustible dusts.

NFPA

National Fire Protection Association
1 Batterymarch Park
Quincy MA 02169-7471

13—16:

Standard for the Installation of Sprinkler Systems

13D—16:

Standard for the Installation of Sprinkler Systems in One- and Two-family Dwellings and Manufactured Homes

70—17:

National Electrical Code

72—16:

National Fire Alarm and Signaling Code

77-14:

Recommended Practice on Static Electricity

Reason:

Combustible dust continues to be an issue of concern with AHJs. While references to NFPA for unique dust hazards can be useful, the entire protection cannot just evolve around ten different NFPA Standards. It is simply impractical to apply standards and only standards without any additional guidance for code users, especially fire inspectors in their daily work. One of the premises in the IFC development has been that the code should contain information for use in the field, while items for plan review can be referenced to other standards since plan review is normally conducted in the office where the information in the standards is accessible. In the field, the inspector needs information to apply to situation in front of him or her.

Similar concerns arise from application of Flammable Finishes that involve spraying and/or dipping operations using flammable liquids. Except for unique applications, it has not been necessary to analyze the size of the flammable liquids droplets/vapors, flammability of materials, etc. Providing appropriate hazard mitigations, including sources of ignition, exhaust, etc. Chapter 24 addresses concerns for a wide range of flammable liquids without the need for inspectors to delve into 10 different standards. This proposed new chapter 22 takes a similar approach. This code

change does not deter from the current Chapter, in that those standards are still imbedded in this new proposed chapter, as appropriate. But the code change provides additional guidelines on how to mitigate dust accumulation and sources of ignition. It also provides guidelines on housekeeping, employee training, operational procedures.

If fire plan reviewer or inspector has additional concerns, it still leaves the door open to requiring additional NFPA Standards and Dust Hazard Analysis. That option is still available with this proposed revision under Section 2205.

Section 2201.1: Exception 1 allows 5 lbs. to address small laboratory type use. Additionally combustible dust has a fire hazard rating of 2 and in some rare cases 3. When comparing to MAQs of other materials with fire hazard rating of 2 typical basic MAQs for these materials are 25 lbs and other materials with fire hazard rating of 3 have typical basic MAQs of 10 lbs. Doubling for a sprinklered building, in Exception 2, also puts things in line with other hazardous materials allowances. The remaining exceptions are listed based on similar exceptions in standards due to lack of major incidences in commonly encountered storage and uses.

Section 2203.1: Collection of accumulated dust is the single most critical method of dust explosion prevention. It is one of the simpler methods of evaluating and addressing prevention. The critical depth layer in Table 2203.1 provides a very general approach for fire inspectors, while Section 2203.1 allows for more complicated analysis by adjusting the critical layer depth and/or determining explosion hazard found in NFPA 654 & 664.

Section 2203.2: It is difficult for an inspector to determine if the equipment is inherently safe and/or the associated electrical has been designed properly unless the equipment is listed. This section also requires maintenance in accordance with manufacturer's instructions. Subsections on markings and signs are provided to avoid injury to personnel if vent panels are dislodged or in the event of an incident.

Section 2203.3.1: Dust collection systems need to draw at the point of generation for maximum efficiency. The exception is included since closed system use of combustible dust where dust is not open to the environment of the room does not need a dust collector. References to mechanical code is provided for location of dust collection system.

Section 2203.3.1.1: The general requirement is to located the dust collector outside of buildings. Exceptions are added to address 1) IMC allowances, 2) wet-type dust collectors which when designed and installed per manufacturer's cut sheets do not pose an explosion hazard since the dust is wetted and therefore is inherently safer inside the building, and 3) references to the different NFPA standards for specific dusts when the dust and the dust collection is detailed and specific to a particular NFPA standard for mitigation of dust explosion.

Section 2203.3.1.2: Source is from California Mechanical Code Table 505.2. These velocities have been used for decades and provide a minimum velocity to move the various particles. Particles of different types and weights require different velocities to properly move the particles.

Section 2203.3.2: Grounding and bonding is required for ducts and conveyors. Added precautions are used for types of ducts and piping that will be difficult to dissipate static electricity.

Section 2203.3.3: In addition to the cleanouts proposed for the dust collection in the International Mechanical Code, a method is needed to access all parts of a conveying system for cleaning and inspection. Lack of cleanouts was one of issues that resulted in the explosion in the Imperial Sugar Company, Port Wentworth GA.

Section 2203.4.1: Although these requirements already apply, sending the code user, who may otherwise be unfamiliar to the National Electric Code is appropriate.

Section 2203.4.2: To avoid sources of ignition from static discharge, grounding and bonding is required for equipment that come in contact with combustible dust.

Section 2203.4.3: Similar language is used in IFC Section 2403.2.7 for Flammable Finishes. Limiting hot works to designated area is critical to avoid additional sources of ignition within areas where combustible dust is used.

Section 2203.4.4: Avoiding heated surfaces in areas subject to explosion hazard is very important aspect of controlling sources of ignition. Some of the language is from IFC Section 2404.6.1.2 for Flammable Finishes and some is from other standards.

Section 2203.4.5: Similar language in IFC 2403.2.8 for Flammable Finishes.

Section 2203.4.6: Similar language in IFC Section 2403.2.6 for Flammable Finishes.

Section 2203.4.7: Similar language in IFC Section 2403.2.2 for Flammable Finishes.

Section 2203.4.8: This section is derived from and references NFPA 652. It addresses unique and very hazardous condition for self-heating materials.

Section 2203.4.9: Basic safety requirements need to be maintained in the event that open flame or fuel fired equipment is needed as part of the processes. These sections provide guidelines on how to safely use these equipment and reduce the probability of an incident.

Section 2203.5: Basic housekeeping is required to limit the accumulation of dust specified in Section 2203.1.

Section 2203.6: Standard Operational Procedures is the business owner's commitment to maintaining the operations safe and equipment in good working condition.

Section 2203.7: Emergency response plan is important for facilities where the a potential dust explosion exists.

Section 2203.8: Training is important for facilities with potential dust explosion hazards to encourage employees into maintaining safe conditions within the facility. Educating employees in understanding that maintenance and housekeeping are key life safety aspects in a facility is important.

Section 2204: Dust explosion screening tests may be necessary for specific types of dust. This section allows the AHJ to require and sends the user to the appropriate NFPA standard and section.

Section 2205: If unique hazards that are not covered by this chapter come up [e.g. design of large dryers in large agricultural and food processing facilities], this section allows fire code official to use these NFPA Standards for specific hazards. Similar language is existing in the current code.

Dust Collection System: New definition is provided in Chapter 2.

Bibliography:

International Fire Code, ICC, Chapter 24.

Also the following referenced NFPA Standards:

NFPA 61: Standard for the Prevention of Fires and Dust Explosions in Agricultural and Food Processing Facilities

NFPA 69: Standard on Explosion Prevention Systems

NFPA 77: Recommended Practice on Static Electricity

NFPA 85: Boiler and Combustion System Hazards Code

NFPA 120: Standard for Fire Prevention and Control in Coal Mines

NFPA 484: Standard for Combustible Metals

NFPA 652: Standard on the Fundamentals of Combustible Dust

NFPA 654: Standard for Prevention of Fire and Dust Explosions from the Manufacturing, Processing and Handling of Combustible Particulate Solids

NFPA 655: Standard for the Prevention of Sulfur Fires and Explosions

NFPA 664: Standard for the Prevention of Fires and Explosions in Wood Processing and Woodworking Facilities

Cost Impact

The code change proposal will not increase or decrease the cost of construction .

Please note that the proposal may increase or decrease the cost impact to construction. It highly depends on the type and scale of combustible dust use. In most cases, we believe not applying NFPA 652 for all cases will reduce the cost of construction.

Analysis: A review of the standard proposed for inclusion in the code, NFPA 77-14 with regard to the ICC criteria for referenced standards (Section 3.6 of CP#28) will be posted on the ICC website on or before April 2, 2018.

Internal ID: 197

F213-18

IFC: 2203.4

Proponent: Matthew Hunter, American Wood Council, representing American Wood Council (mhunter@awc.org)

2018 International Fire Code

Revise as follows:

2203.4 Housekeeping. Accumulation of *combustible dust* shall be kept to a minimum in the interior of buildings. Accumulated *combustible dust* shall be collected by vacuum cleaning or other means that will not place *combustible dust* into suspension in air. Forced air or similar methods shall not be used to remove dust from surfaces.

Exception: Forced air or similar methods shall be permitted to remove dust per NFPA 652, NFPA 654, or NFPA 664.

Reason:

The NFPA standards governing facilities that produce combustible dust as part of the manufacturing process have comprehensive housekeeping requirements. Although the International Fire Code prohibits the use of forced air to clean hard to reach areas in the manufacturing equipment, the NFPA standards permit its use for housekeeping under certain conditions. The safe use of compressed air in accordance with these standards is common practice in the industry. This proposal will bring consistency and uniformity within the standards listed, which are referenced in Table 2204.1.

Cost Impact

The code change proposal will not increase or decrease the cost of construction .

This proposed language may facilitate a slight cost savings as a broader flexibility of approved housekeeping methods will be available to the plant operator to choose from to reduce or eliminate combustible dust from plant infrastructure.

Internal ID: 684

F214-18

IFC: 2303.1, 2304.2.4

Proponent: Stephen DiGiovanni, representing self (sdigiovanni@clarkcountynv.gov); Lynn Nielson, representing Self

2018 International Fire Code

Revise as follows:

2303.1 Location of dispensing devices. Dispensing devices shall be located as follows:

1. Ten feet (3048 mm) or more from *lot lines*.
2. Ten feet (3048 mm) or more from buildings having combustible exterior wall surfaces or buildings having noncombustible exterior wall surfaces that are not part of a 1-hour fire-resistance-rated assembly or buildings having combustible overhangs.
Exception: Canopies constructed in accordance with the International Building Code providing weather protection for the fuel islands.
3. Such that all portions of the vehicle being fueled will be on the premises of the motor fuel-dispensing facility.
4. Such that the nozzle, where the hose is fully extended, will not reach within 5 feet (1524 mm) of building openings.
5. Twenty feet (6096 mm) or more from fixed sources of ignition.
6. Such that fuel dispensing is in view of the attendant at attended self-service motor fuel-dispensing facilities, as required by Section 2304.2.4.

2304.2.4 Obstructions to view. ~~Dispensing devices shall be in clear view of the attendant.~~ The attendant shall have a direct line of sight to observe fuel dispensing operations at all times. Obstructions shall not be placed between the dispensing area and the attendant.

Exception: Video monitoring systems shall be permitted to supplement direct line of sight supervision where approved by the fire code official.

Reason:

Newer fueling stations are typically accompanied by convenience stores. As stores become larger and more elaborate, the design is changing such that attendants operate more as cashiers, and are frequently oriented towards the convenience store merchandise area, and not towards the dispensers. Further, larger fueling stations have multiple dispensing islands that are often set at angles where all of the dispensers can not be viewed by an attendant. Convenience store marketing using posters, signs and or displays further obstruct direct view of dispensing areas for the attendant.

Commentary to ICC code has referred to the use of video cameras for viewing dispensing areas, but the code has not explicitly permitted video cameras to supplement direct view of dispensing areas. This proposal intends to clarify that, subject to approval by the fire code official, it is permissible to supplement direct view of dispensers by the addition of video monitoring. This will allow for better viewing of dispensing areas, than is possible with some newer designs of fueling stations. Video monitoring will enhance the ability for the attendant to view, supervise and control the dispensing of fuel.

Cost Impact

The code change proposal will increase the cost of construction .

While the use of video monitoring is optional as proposed, where the option to supplement direct view is employed, it is expected that there may be some additional costs. It is expected that some of these fueling stations may already have video monitoring for security purposes, and even if additional cameras are required by this requirement, much of the costs will likely already be mitigated.

Internal ID: 1780

F215-18

IFC: 2308.1, 2308.2, 2308.2.3 (New), 2308.2.4. (New), Chapter 80

Proponent: Ted Williams, American Gas Association, representing American Gas Association (twilliams@aga.org)

2018 International Fire Code

Revise as follows:

2308.1 General. Motor fuel-dispensing facilities for compressed natural gas (CNG) fuel shall be in accordance with this section, ~~and Chapter 53 and International Fuel Gas Code Section 413.~~

2308.2 Approvals. Storage vessels and equipment used for the storage, compression or dispensing of CNG shall be *approved* or *listed* in accordance with Sections 2308.2.1 ~~and 2308.2.2~~ through 2308.2.4.

Add new text as follows:

2308.2.3 Residential fueling appliance (RFA). Residential fueling appliances shall be listed to CSA/ANSI NGV 5.1 and installed in accordance with installation requirements of CSA/ANSI NGV 5.1, manufacturer installation instructions, and the International Fuel Gas Code Section 413. The capacity of an RFA shall not exceed 5 standard cubic feet per minute (0.14 standard cubic meter/min) of natural gas.

2308.2.4 Vehicle fueling appliance (VFA). Non-residential fueling appliances shall be listed as VFAs to CSA/ANSI NGV 5.2 and installed in accordance with installation requirements of CSA/ANSI NGV 5.2, manufacturer installation instructions, and requirements of the International Fuel Gas Code Section 413 for VFAs. The capacity of VFA shall not exceed 10 standard cubic feet per minute (0.28 standard cubic meter/min) of natural gas.

Add new standard(s) follows:

ANSI

American National Standards
Institute
25 West 43rd Street, 4th Floor
New York NY 10036

CSA/ANSI NGV 5.2—2017:

Vehicle Fueling Appliances (VFA)

CSA/ANSI NGV 5.1-2016:

Residential Fueling Appliances

Reason:

This proposal adopts “residential fueling appliance” (RFA) and light-commercial “vehicle fueling appliance” (VFA) coverage for listed appliances from ANSI-recognized standards CSA/ANSI NGV 5.1 and CSA/ANSI NGV 5.2, respectively, and applies installation requirements from those standards, manufacturer installation instructions, and proposed parallel requirements to go into the International Fuel Gas Code, Section 413. Requirements in the two CSA standards cover design, installation, labeling, and other requirements for these two classes of listed appliances and differentiate fueling appliances based on input flow rates and other requirements applicable to residential occupancies in the case of NGV 5.1 and light-commercial occupancies in the case of NGV 5.2. RFA coverage is already found in IFGC Section 413; VFA coverage is proposed as new coverage in the IFGC and IFC.

NFPA 52-2016 already defines and differentiates RFAs and VFAs based on limitations on input flow capacities: 5 SCFM for RFAs and 10 SCFM for VFAs for which coverage is now proposed for both the IFGC and IFC. Parallel coverage RFAs and VFAs is proposed to a new edition of NFPA 52 (2019 edition); however, final action on those proposals has not been taken at the time of the submission of this proposal.

Cost Impact

The code change proposal will not increase or decrease the cost of construction .

The proposal addresses appliance requirements, including installation requirements, unrelated to facility construction.

Analysis: A review of the standards proposed for inclusion in the code, CSA/ANSI NGV 5.2—2017 and CSA/ANSI NGV 5.1-16, with regard to the ICC criteria for referenced standards (Section 3.6 of CP#28) will be posted on the ICC website on or before April 2, 2018.

F216-18

IFC: 2309.1

Proponent: Spencer Quong, representing Toyota Motor North America (squong@yahoo.com); Robert Davidson, Davidson Code Concepts, LLC, representing Toyota, USA (RJD@davidsoncodeconcepts.com)

2018 International Fire Code

2309.1 General. Hydrogen motor fuel-dispensing and generation facilities shall be in accordance with this section, ~~and Chapter 58,~~ and NFPA 2. Where a fuel-dispensing facility includes a repair garage, the repair operation shall comply with Section 2311.

Reason:

Adding a reference to NFPA 2 Hydrogen Technologies Code to the general requirements for dispensing and generation will provide additional coordination with the detailed requirements for hydrogen dispensing and generating systems developed by the Hydrogen Technologies Code Technical Committee.

Bibliography:

<http://www.nfpa.org/codes-and-standards/all-codes-and-standards/list-of-codes-and-standards/detail?code=2>

Cost Impact

The code change proposal will not increase or decrease the cost of construction .

The requirements in NFPA 2 are standard for the hydrogen industry and are already implemented at dispensing and generating facilities.

Internal ID: 1334

F217-18

IFC: 2309.2.2, 2309.4

Proponent: Spencer Quong, representing Toyota Motor North America (squong@yahoo.com); Robert Davidson, Davidson Code Concepts, LLC, representing Toyota, USA (RJD@davidsoncodeconcepts.com)

2018 International Fire Code

Revise as follows:

2309.2.2 Listed or approved equipment. Hoses, hose connections, compressors, hydrogen generators, dispensers, motor-fueling connections and electrical equipment used for hydrogen shall be *listed or approved for use with hydrogen*. ~~Hydrogen motor-fueling connections shall be *listed and labeled* or *approved* for use with hydrogen.~~

2309.4 Dispensing into motor vehicles at self-service hydrogen motor fuel-dispensing facilities. Self-service hydrogen motor fuel-dispensing systems, including key, code and card lock dispensing systems, shall be limited to the filling of permanently mounted fuel containers on hydrogen-powered vehicles.

In addition to the requirements in Section 2311, the *owner* of a self-service hydrogen motor fuel-dispensing facility shall provide for the safe operation of the system by complying with this code and the fueling protocols in NFPA 2 and through the institution of a fire safety plan submitted in accordance with Section 404, the training of employees and operators who use and maintain the system in accordance with Section 406, and provisions for hazard communication in accordance with Section 407.

Reason:

The proposed makes two simple modifications.

Section 2309.2.2 is restructured. By pulling "motor-fueling connections into the first sentence there is no need for the second sentence.

Section 2309.4 is modified by adding a pointer to fueling protocols that are in NFPA 2. These protocols need to be referenced to provide for the "safe operation of the system".

Bibliography:

<http://www.nfpa.org/codes-and-standards/all-codes-and-standards/list-of-codes-and-standards/detail?code=2>

Cost Impact

The code change proposal will not increase or decrease the cost of construction .

Requirements in NFPA2 are already used by manufacturers of hydrogen dispensing and generating facilities.

Internal ID: 1336

F218-18

IFC: 2309.4

Proponent: Spencer Quong, representing Toyota Motor North America (squong@yahoo.com); Robert Davidson, Davidson Code Concepts, LLC, representing Toyota, USA (RJD@davidsoncodeconcepts.com)

2018 International Fire Code

Revise as follows:

2309.4 Dispensing into motor vehicles at self-service hydrogen motor fuel-dispensing facilities. ~~Self-service hydrogen~~ Hydrogen motor fuel-dispensing systems, including key, code and card lock dispensing systems, shall be limited to the filling of permanently mounted fuel containers on hydrogen-powered vehicles.

In addition to the requirements in Section 2311, the *owner* of a ~~self-service~~ hydrogen motor fuel-dispensing facility shall provide for the safe operation of the system through the institution of a fire safety plan submitted in accordance with Section 404, the training of employees and operators who use and maintain the system in accordance with Section 406, and provisions for hazard communication in accordance with Section 407.

Reason:

When the requirements for hydrogen motor-fueling were added to the code dispensing stations were experimental and use of the systems to fuel motor vehicle was restricted and controlled. The safety requirements for hydrogen motor-fuel dispensing has matured over the years and as a result there are over 30 public hydrogen motor-fuel stations installed in California alone with public and private hydrogen motor-fuel stations located in other states, and the numbers will increase. Some stations are self service and others are not. The requirements in 2309.4 should be for all hydrogen stations whether they are self-service or filling is done by an attendant.

Cost Impact

The code change proposal will not increase or decrease the cost of construction .

Both self service and full service hydrogen stations adopt the requirements in 2309, so there should not be an impact to cost.

Internal ID: 1337

F219-18

IFC: 202 (New), 2309.4, 2311.8.11, 2311.8

Proponent: Spencer Quong, representing Toyota Motor North America (squong@yahoo.com)

2018 International Fire Code

Add new definition as follows:

TANK, MOTOR VEHICLE FUEL A tank permanently mounted on a motor vehicle to store a gas or liquid fuel which is used for propulsion.

Revise as follows:

2309.4 Dispensing into motor vehicles at self-service hydrogen motor fuel-dispensing facilities. Self-service hydrogen motor fuel-dispensing systems, including key, code and card lock dispensing systems, shall be limited to the filling of permanently mounted motor vehicle fuel containers tanks on hydrogen-powered vehicles.

In addition to the requirements in Section 2311, the *owner* of a self-service hydrogen motor fuel-dispensing facility shall provide for the safe operation of the system through the institution of a fire safety plan submitted in accordance with Section 404, the training of employees and operators who use and maintain the system in accordance with Section 406, and provisions for hazard communication in accordance with Section 407.

2311.8 Repair garages for vehicles fueled by lighter-than-air fuels. The room, motor vehicle repair booth or motor vehicle repair space containing repair garage activities for the conversion or repair of vehicles that use CNG, LNG, hydrogen or other lighter-than-air motor fuels shall be in accordance with Sections 2311.8 through 2311.8.11 in addition to the other requirements of Section 2311. Repair garages for the repair of vehicles that use hydrogen fuel shall be in accordance with this code and NFPA 2.

Exceptions:

1. Repair garages where work is conducted only on vehicles that have been defueled and their systems purged with nitrogen gas, and where standard operating procedures to document and maintain the fueling status throughout repair operations are approved.
2. Repair garages where work is not performed on the fuel system and is limited to exchange of parts and maintenance not requiring open flame or welding on the CNG-, LNG-, hydrogen- or other lighter-than-air-fueled motor vehicle.
3. Repair garages for hydrogen-fueled vehicles where work is not performed on the ~~hydrogen storage tank~~ motor vehicle fuel tank and is limited to the exchange of parts and maintenance not requiring open flame or welding on the hydrogen-fueled vehicle. During the work, the entire hydrogen fuel system shall contain less than 200 cubic feet (5.6 m³) of hydrogen.
4. Repair garages for natural-gas-fueled vehicles where work is not being performed on the motor vehicle fuel storage tank, and is limited to the exchange of parts and maintenance not requiring open flame or welding on the natural-gas-fueled vehicle. During the work, the natural gas, in the motor vehicle fuel tank shall contain a pressure of not more than 250 psi at 70°F (1724 kPa at 21°C).

2311.8.11 Defueling equipment required at vehicle maintenance and repair facilities. Facilities for repairing or replacing hydrogen fuel tanks on hydrogen-fueled vehicles shall have equipment to defuel vehicle storage tanks. Where work must be performed on a vehicle's motor vehicle fuel storage tank for the purpose of maintenance, repair or cylinder certification, defueling and purging shall be conducted in accordance with Section 2309.6 and NFPA 2.

Reason:

The addition of "motor vehicle fuel tank" definition helps clarify the difference between a fuel 'tank' in a car and other containers and tanks which are currently defined in the IFC as having volumes that do not match the volume of motor fuel 'tanks'.

Cost Impact

The code change proposal will not increase or decrease the cost of construction .

The proposal is a clarifying definition and has no impact on cost

Internal ID: 1639

F220-18

IFC: 2309.4

Proponent: Spencer Quong, representing Toyota Motor North America (squong@yahoo.com); Robert Davidson, Davidson Code Concepts, LLC, representing Toyota, USA (RJD@davidsoncodeconcepts.com)

2018 International Fire Code

Revise as follows:

2309.4 Dispensing into motor vehicles at self-service hydrogen motor fuel-dispensing facilities. Self-service hydrogen motor fuel-dispensing systems, including key, code and card lock dispensing systems, shall be limited to the filling of permanently mounted fuel containers on hydrogen-powered vehicles.

In addition to the requirements in Section 2311, the *owner* of a self-service hydrogen motor fuel-dispensing facility shall provide for the safe operation of the system through the institution of a fire safety plan submitted in accordance with Section 404, the training of employees and operators who use and maintain the system in accordance with Section 406, and provisions for hazard communication in accordance with Section 407.

Exception: Filling of non-permanently mounted storage containers or tanks for motor fuel-dispensing system testing purposes is permitted.

Reason:

Hydrogen dispensing facilities require testing which uses tanks which may not be permanently mounted on a hydrogen fueled vehicle. This testing is important to ensure the proper function of the stations. The exception allows testing to occur.

Cost Impact

The code change proposal will not increase or decrease the cost of construction .

The proposed text allows for testing at the station and does not affect the cost.

Internal ID: 1338

F221-18

IFC: 2309.6

Proponent: Spencer Quong, representing Toyota Motor North America (squong@yahoo.com); Robert Davidson, Davidson Code Concepts, LLC, representing Toyota, USA (RJD@davidsoncodeconcepts.com)

2018 International Fire Code

Revise as follows:

2309.6 Repairs, purging, defueling and discharge. The repair, purging, defueling or discharge activities associated with hydrogen motor fuel ~~supply systems and dispensing and generation systems, storage tanks~~ and the installation of the systems shall be in accordance with Chapters 53 and 58 and NFPA 2.

Exception: The motor vehicle fuel tank and the fuel supply piping from the motor vehicle fuel storage tank to the engine compartment on a motor vehicle or forklift unless the fuel tank is required to be defueled in accordance with Section 2311.8.11.

Reason:

The proposed text clarifies that this section is primarily intended to apply to the fixed facility equipment and only applies to a motor vehicle fuel tank when required to be defueled by Section 2311.8.1

Cost Impact

The code change proposal will not increase or decrease the cost of construction .

The proposed text only clarifies the use of the defueling equipment

Internal ID: 1340

F222-18

IFC: 2310.4.1, 2310.4.2

Proponent: Andrew Klein, representing Lakeside Fueling (andrew@asklein.com)

2018 International Fire Code

Revise as follows:

~~2310.4.2~~**2310.4.1 Class I, II or III liquid fuels.** Fueling of floating marine craft with Class I, II or III fuels at other than a marine motor fuel-dispensing facility shall be in accordance with all of the following:

1. The premises and operations shall be *approved* by the *fire code official*.
2. ~~Tank vehicles and fueling operations~~ Fueling operations from tank vehicles shall comply with Section 5706.6.
3. The dispensing nozzle shall be of the *listed* automatic-closing type ~~without~~ with a latch-open device. A listed break-away device shall be provided at the nozzle.
4. Nighttime deliveries shall only be made in lighted areas.
5. ~~The tank vehicle flasher~~ Flasher lights shall be in operation on the marine fueling vehicle while dispensing.
6. Fuel expansion space shall be left in each fuel tank to prevent overflow in the event of temperature increase.

~~2310.4.1~~**2310.4.2 Additional requirements for Class I liquid fuels.** Fueling of floating marine craft with Class I fuels at other than a marine motor fuel-dispensing facility ~~is prohibited~~ shall be in accordance with all of the following:

1. Marine fueling shall not take place within 25 feet (7620 mm) of buildings or combustible storage.
2. Smoking, open flames, and other sources of ignition shall be prohibited within 25 feet (7620 mm) of fuel dispensing activities.
3. The fuel delivery vehicle shall have an approved grounding system that is employed prior to and throughout fueling activities.
4. An approved portable fire extinguisher complying with Section 906 with a minimum rating of 4A-80-B:C shall be provided on the marine fueling vehicle with signage clearly indicating its location.
5. Pumps, meters and hose assemblies shall be listed and approved.

Reason:

The current code regulations that permit the fueling of marine vehicles at other than approved marine service stations was added into the 2000 edition of the IFC (Code Change Proposal F600-99) due to the need to refuel commercial fishing boats that came to dock along coastal and waterway areas where there were no marine service stations. At the time, those boats operated on diesel (Class II liquid), and there was no need for refueling with gasoline (Class I liquid).

There is now both a need and a demand for gasoline delivery to marine vehicles in areas where marine service stations are not available and for the fueling of racing boats at events. Current code language prohibits such fueling simply because specific requirements were never developed. This proposal provides requirements to address the additional hazards presented by Class I liquids should such fueling be approved by the fire code official.

The modifications made to the existing language take into consideration the different types of fueling vehicles, which are not all tank vehicles. The requirement that nozzles have a latch-open device brings this section into consistency with other fueling sections of the code and recognizes the operational and safety benefits of such a nozzle.

Cost Impact

The code change proposal will not increase or decrease the cost of construction .

This code change proposal provides the requirements to safely perform a previously prohibited operation, when approved by the fire code official.

Internal ID: 344

F223-18

IFC: 2311.8

Proponent: Robert Davidson, Davidson Code Concepts, LLC, representing Toyota, USA (rjd@davidsoncodeconcepts.com); Spencer Quong, representing Toyota Motor North America (squong@yahoo.com)

2018 International Fire Code

Revise as follows:

2311.8 Repair garages for vehicles fueled by lighter-than-air fuels. The room, motor vehicle repair booth or motor vehicle repair space containing repair garage activities for the conversion or repair of vehicles that use CNG, LNG, hydrogen or other lighter-than-air motor fuels shall be in accordance with Sections 2311.8 through 2311.8.11 in addition to the other requirements of Section 2311. Repair garages for the repair of vehicles that use hydrogen fuel shall be in accordance with this code and NFPA 2.

Exceptions:

1. Repair garages where work is conducted only on vehicles that the motor fuel tank and system have been defueled and ~~their systems~~ the motor fuel tank have been purged with nitrogen gas, and where standard operating procedures to document and maintain the fueling status throughout repair operations are approved.
2. Repair garages where work is not performed on the fuel system and is limited to exchange of parts and maintenance not requiring open flame or welding on the CNG-, LNG-, hydrogen- or other lighter-than-air-fueled motor vehicle.
3. Repair garages for hydrogen-fueled vehicles where work is not performed on the hydrogen storage tank and is limited to the exchange of parts and maintenance not requiring open flame or welding on the hydrogen-fueled vehicle. During the work, the entire hydrogen fuel system shall contain less than 200 cubic feet (5.6 m³) of hydrogen.
4. Repair garages for natural-gas-fueled vehicles where work is not being performed on the fuel storage tank, and is limited to the exchange of parts and maintenance not requiring open flame or welding on the natural-gas-fueled vehicle. During the work, the natural gas, in the vehicle fuel tank shall contain a pressure of not more than 250 psi at 70°F (1724 kPa at 21°C).

Reason:

The purpose of this proposal is to modify the language to require the motor fuel tank and system to be defueled, but only the fuel tank to be purged with nitrogen rather than the entire "system".

The small diameter fuel line running from the motor fuel tank to the engine compartment contains a de minimus amount of gaseous fuel that does not pose a risk to the repair facility. The majority of this gaseous fuel is during the defueling process making nitrogen purging of this portion of the system unnecessary.

Cost Impact

The code change proposal will not increase or decrease the cost of construction .

This language does not impact construction and will have no impact on construction costs, however, it can reduce operational expenses by eliminating an unnecessary step.

Internal ID: 1657

F224-18

IFC: 2311.8

Proponent: Robert Davidson, Davidson Code Concepts, LLC, representing Toyota, USA (rjd@davidsoncodeconcepts.com); Spencer Quong, representing Toyota Motor North America (squong@yahoo.com)

2018 International Fire Code

Revise as follows:

2311.8 Repair garages for vehicles fueled by lighter-than-air fuels. The room, motor vehicle repair booth or motor vehicle repair space containing repair garage activities for the conversion or repair of vehicles that use CNG, LNG, hydrogen or other lighter-than-air motor fuels shall be in accordance with Sections 2311.8 through 2311.8.11 in addition to the other requirements of Section 2311. Repair garages for the repair of vehicles that use hydrogen fuel shall be in accordance with this code and NFPA 2.

Exceptions:

1. Repair garages where work is conducted only on vehicles that have been defueled and their systems purged with nitrogen gas, and where standard operating procedures to document and maintain the fueling status throughout repair operations are approved.
2. Repair garages where work is not performed on the fuel system and is limited to exchange of parts and maintenance not requiring open flame or welding on the CNG-, LNG-, hydrogen- or other lighter-than-air-fueled motor vehicle. Movement of a subassembly upon which the motor fuel tank remains mounted to allow access to other parts of the vehicle that are not a portion of the fuel system shall be permitted.
3. Repair garages for hydrogen-fueled vehicles where work is not performed on the hydrogen storage tank and is limited to the exchange of parts and maintenance not requiring open flame or welding on the hydrogen-fueled vehicle. During the work, the entire hydrogen fuel system shall contain less than 200 cubic feet (5.6 m³) of hydrogen.
4. Repair garages for natural-gas-fueled vehicles where work is not being performed on the fuel storage tank, and is limited to the exchange of parts and maintenance not requiring open flame or welding on the natural-gas-fueled vehicle. During the work, the natural gas, in the vehicle fuel tank shall contain a pressure of not more than 250 psi at 70°F (1724 kPa at 21°C).

Reason:

With motor vehicles today it is common to be required to move a subassembly to access the part needing repair or replacement. At times this includes the subassembly the motor fuel tank is mounted to.

There are varying opinions on the part on fire code officials on whether or not this can be done without defueling and nitrogen purging the fuel tank. Some consider that repair work "on the motor fuel tank and system" other do not.

The added language is intended to firmly state that movement of the subassembly the motor fuel tank is permitted under this exception which is limited to the exchange of parts and no use of open flame or welding. The tank remains firmly mounted to its mounting chassis and is not free to drop, roll or otherwise move during this process and as such does not present any additional safety concerns.

Cost Impact

The code change proposal will not increase or decrease the cost of construction .

This proposal does not impact the cost of construction. It can reduce the operational costs in those locations where defueling and purging has been required.

Internal ID: 1676

F225-18

IFC: 2311.8

Proponent: Spencer Quong, representing Toyota Motor North America (squong@yahoo.com)

2018 International Fire Code

Revise as follows:

2311.8 Repair garages for vehicles fueled by lighter-than-air fuels. The room, motor vehicle repair booth or motor vehicle repair space containing repair garage activities for the conversion or repair of vehicles that use CNG, LNG, hydrogen or other lighter-than-air motor fuels shall be in accordance with Sections 2311.8 through 2311.8.11 in addition to the other requirements of Section 2311. Repair garages for the repair of vehicles that use hydrogen fuel shall be in accordance with this code and NFPA 2.

Exceptions:

1. Repair garages where work is conducted only on vehicles that have been defueled and their systems purged with nitrogen gas, and where standard operating procedures to document and maintain the fueling status throughout repair operations are approved.
2. Repair garages where work is not performed on the fuel system and is limited to exchange of parts and maintenance not requiring open flame or welding on the CNG-, LNG-, hydrogen- or other lighter-than-air-fueled motor vehicle.
3. Repair garages for hydrogen-fueled vehicles where work is not performed on the hydrogen storage tank and is limited to the exchange of parts and maintenance not requiring open flame or welding on the hydrogen-fueled vehicle. During the work, the entire hydrogen fuel system shall contain less than ~~200-400~~ cubic feet (~~5.6-11.2~~ m³) of hydrogen.
4. Repair garages for natural-gas-fueled vehicles where work is not being performed on the fuel storage tank, and is limited to the exchange of parts and maintenance not requiring open flame or welding on the natural-gas-fueled vehicle. During the work, the natural gas, in the vehicle fuel tank shall contain a pressure of not more than 250 psi at 70°F (1724 kPa at 21°C).

Reason:

Exception 3 of Section 2311.7 is intended to allow work on the fuel system, except for the hydrogen storage tank without having to install additional ventilation and gas detection systems in the repair garage. The vehicle's shutoff valve must be securely closed on the fuel storage container so that it is a closed system and no gas can escape during maintenance operations. This proposal is increasing the allowable amount of hydrogen in the sealed fuel tank from 200 to 400 cubic feet (NTP).

Although each hydrogen passenger vehicle is different, typically their storage containers hold between 5000-50000 cubic feet (NTP) of hydrogen at high pressure (5000-10000 psi). However, the hydrogen leaving the storage container is regulated to a lower pressure, typically less than 250 psi and less than 10 cubic feet (NTP) of hydrogen.

Any release of hazardous material can pose a problem. However, this proposal addresses the issues in two ways. First, it requires that the shutoff valve on the fuel storage container to be securely closed. Hydrogen vehicles are required to have a manual valve that can be shut off for maintenance¹. In most vehicles, the shutoff valve fails shut, so the standard operating procedure to ensure that the valve is closed is to disconnect the 12V battery. For manual valves, it can be tagged and locked in the off position. Since almost all of the hydrogen is in the fuel storage container, this requirement will ensure only a minimal amount of hydrogen is left in the remainder of the fuel system.

Second, in the event that the fuel storage container is opened during repairs and all of the hydrogen is allowed to escape, this proposal requires that the entire fuel system be defueled to less than 400 cubic feet (NTP). This is less than 40% of the Maximum Allowable Quantity (MAQ) per control area listed in Table 5003.1.1(1) through 5003.1.1(4).

With more and more hydrogen vehicles on the road, there is a need to be able to work on the low pressure side of the fuel system at any repair garage without adding additional ventilation and gas detection systems. This proposal allows for this work as long as two requirements are met: the fuel storage container is closed and the amount of hydrogen is less than the existing IFC limitations for hazardous materials, and flammable gases. Already, repair garages have industrial cylinders of acetylene and other flammable gases without additional ventilation and detection equipment. Even if the repair garages meet the requirements in this exception, they will still need to be in accordance with Sections 5001 and 5003.

Bibliography:

"Standard for Fuel Systems in Fuel Cell and Other Hydrogen Vehicles." Society of Automotive Engineers. 2013.

http://standards.sae.org/j2579_201303/

Cost Impact

The code change proposal will not increase or decrease the cost of construction .

The proposal clarifies the quantity of hydrogen which is allowed in the tank before upgrades are required, but does not impact the type or cost of upgrades.

Internal ID: 1335

F226-18

IFC: 2311.8

Proponent: Spencer Quong, representing Toyota Motor North America (squong@yahoo.com); Robert Davidson, Davidson Code Concepts, LLC, representing Toyota, USA (RJD@davidsoncodeconcepts.com)

2018 International Fire Code

Revise as follows:

2311.8 Repair garages for vehicles fueled by lighter-than-air fuels. The room, motor vehicle repair booth or motor vehicle repair space containing repair garage activities for the conversion or repair of vehicles that use CNG, LNG, hydrogen or other lighter-than-air motor fuels shall be in accordance with Sections 2311.8 through 2311.8.11 in addition to the other requirements of Section 2311. Repair garages for the repair of vehicles that use hydrogen fuel shall be in accordance with this code and NFPA 2.

Exceptions:

1. Repair garages where work is conducted only on vehicles that have been defueled and their systems purged with nitrogen gas, and where standard operating procedures to document and maintain the fueling status throughout repair operations are approved.
2. Repair garages where work is not performed on the fuel system and is limited to exchange of parts and maintenance not requiring open flame or welding on the CNG-, LNG-, hydrogen- or other lighter-than-air-fueled motor vehicle.
3. Repair garages for hydrogen-fueled vehicles where work is not performed on the hydrogen storage tank and is limited to the exchange of parts and maintenance not requiring open flame or welding on the hydrogen-fueled vehicle. During the work, the entire hydrogen fuel system shall contain less than 200 cubic feet (5.6 m³) of hydrogen.
4. Repair garages for natural-gas-fueled vehicles where work is not being performed on the fuel storage tank, and is limited to the exchange of parts and maintenance not requiring open flame or welding on the natural-gas-fueled vehicle. During the work, the natural gas, in the vehicle fuel tank shall contain a pressure of not more than 250 psi at 70°F (1724 kPa at 21°C).
5. Where approved by the fire code official, repair garages for hydrogen-fueled vehicles where an analysis has been submitted documenting that a flammable mixture in air will not occur in the room or space if the hydrogen is released from the motor fuel tank..

Reason:

The purpose of this proposal is to eliminate the extra protection features for hydrogen motor vehicle repair garages in those cases where an analysis has been performed and submitted documenting that flammable mixture of the hydrogen and air will not occur if the hydrogen is released from its tank.

The application of this exception would be conditioned upon the approval of the fire code official since the necessary analysis, including computer modeling, would be facility specific including the dimensions of the room or space.

Cost Impact

The code change proposal will decrease the cost of construction .

This change would decrease the cost of construction in those cases where the application of the analysis exception is approved.

Internal ID: 1333

F227-18

IFC: 2311.8, Chapter 80

Proponent: Ted Williams, American Gas Association, representing American Gas Association (twilliams@aga.org)

2018 International Fire Code

Revise as follows:

2311.8 Repair garages for vehicles fueled by lighter-than-air fuels. The room, motor vehicle repair booth or motor vehicle repair space containing repair garage activities for the conversion or repair of vehicles that use CNG, LNG, hydrogen or other lighter-than-air motor fuels shall be in accordance with Sections 2311.8 through 2311.8.11 in addition to the other requirements of Section 2311. Repair garages for the repair of vehicles that use hydrogen fuel shall be in accordance with this code and NFPA 2.

Exceptions:

1. Repair garages where work is conducted only on vehicles that have been defueled and their systems purged with nitrogen gas, and where standard operating procedures to document and maintain the fueling status throughout repair operations are approved.
2. Repair garages where work is not performed on the fuel system and is limited to exchange of parts and maintenance not requiring open flame or welding on the CNG-, LNG-, hydrogen- or other lighter-than-air-fueled motor vehicle.
3. Repair garages for hydrogen-fueled vehicles where work is not performed on the hydrogen storage tank and is limited to the exchange of parts and maintenance not requiring open flame or welding on the hydrogen-fueled vehicle. During the work, the entire hydrogen fuel system shall contain less than 200 cubic feet (5.6 m³) of hydrogen.
4. Repair garages for natural-gas-fueled vehicles where work is not being performed on the fuel storage tank, and is limited to the exchange of parts and maintenance not requiring open flame or welding on the natural-gas-fueled vehicle. During the work, the natural gas, in the vehicle fuel tank shall contain a pressure of not more than 250 psi at 70°F (1724 kPa at 21°C).
5. Repair garages for natural-gas-fueled vehicles where garage design and systems meet the requirements of CSA B401.

Add new standard(s) follows:

CSA B401-2018 Natural Gas Vehicle (NGV) Maintenance Facilities Code

Reason:

CSA B401-2019, "NGV Maintenance Facilities Code," will serve as the Canadian code for maintenance facilities for CNG and LNG vehicles. Inclusion of B401 for design of NGV repair garages as an option in the IFC (by exception) provides an opportunity for greater harmonization of requirements across North America. Public review and comment resolution on B401 will conclude prior to the IFC Public Comments deadline. B401 requirements are also being proposed for revision of NFPA 30A-2021, which has a deadline for Public Input in June 2018. Under other timetables, it would be preferred to first pursue adoption of B401 requirements in NFPA 30A and then use NFPA 30A as the basis for IFC proposals. However, final action on NFPA 30A-2021 in April 2020 makes it impractical for planning U. S. adoption of B401 requirements in this way until the 2024 IFC code cycle.

A major benefit in adding B401 as an option for NGV repair garages is the implementation of requirements for classifications of "repair areas" within the repair garages rather than beginning with the presumption that all areas of the garages have to meet the same requirements for "NGV repair garages." Applying all requirements uniformly works well for new-built NGV repair garages but has been shown to be impractical for existing repair garages where NGV maintenance operations are phased in to maintenance operations over time. The 2018 edition of the IFC provides some remedy for this situation by providing distinctions of "major repair" and "minor repair" space requirements (Section 2311.8, including the current exceptions) and separate requirements for "repair booths" (IFC Section 2311.8.4) and "repair spaces" (IFC Section 2311.8.5). In contrast, however, B401 starts with area classification for facilities and, thus, presents a clearer basis for enforcing authorities to apply different requirements for different areas of the facility. As some examples of repair area classification criteria, B401 uses a refinement of "major" and "minor" repairs as the IFC does, along with the IFC on-board CNG fuel pressure threshold of 250 psig as a criterion for repair area classification in CNG repair areas. Requirements are differentiated for roofs, ceilings, walls, partitions, door and penetrations, pits, floors and drains, means of egress, electrical classification, gas detection, purge ventilation, HVAC,

and hot work and presence of other ignition sources. Overall, design criteria are consistent between existing IFC requirements and B401. General facility requirements cover facility requirements for gas and fire detection, alarms, fire suppression, safety and security, and signage. In a number of these areas, B401 provides clearer requirements than the current edition of NFPA 30A and, in some places, greater detail than the IFC does currently.

Cost Impact

The code change proposal will not increase or decrease the cost of construction .

The code change proposal will not increase or decrease the cost of construction across the population of repair garages for NGVs. However, construction costs for retrofitting existing NGV repair garages are likely to be reduced by limiting the extent of coverage of systems intended to address natural gas releases and oversizing of systems and equipment.

Analysis: A review of the standard proposed for inclusion in the code, CSA B401-2018, with regard to the ICC criteria for referenced standards (Section 3.6 of CP#28) will be posted on the ICC website on or before April 2, 2018.

Internal ID: 2236

F228-18

IFC: 2404.3.3.6

Proponent: Geoffrey Raifsnider, Global Finishing Solutions, representing Self

2018 International Fire Code

Revise as follows:

2404.3.3.6 Size. The aggregate area of spray booths in a building shall not exceed the lesser of 10 percent of the area of any floor of a building or the basic area allowed for a Group H-2 occupancy without area increases, as set forth in the International Building Code. ~~The area of an individual spray booth in a building shall not exceed the lesser of the aggregate size limit or 1,500 square feet (139 m²).~~

Exception: One individual booth not exceeding 500 square feet (46 m²).

Reason:

This section does not take into account that regardless of the footprint of the spray booth the safety ventilation increases as the amount of material sprayed increases in order to meet the requirements of 2404.7.3. In addition, the amount of paint stored within a spray booth does not increase with size. Therefore size should not be a factor in determining the hazard level. A spray booth, regardless of size, that meets the requirements of Chapter 24 provides a safe and reliable piece of equipment. This requirement puts a financial burden on the purchaser who requires a single larger enclosed spray area for their process. NFPA 33 does not have a size limitation. The proposed change brings this section in alignment with current edition of NFPA 33.

Cost Impact

The code change proposal will decrease the cost of construction .

This change will allow use of spray booth construction which is less expensive than fire rated construction.

Internal ID: 2300

F229-18

IFC: 2404.3.4 (New)

Proponent: Geoffrey Raifsnider, Global Finishing Solutions, representing Self

2018 International Fire Code

Add new text as follows:

2404.3.4 Limited Finishing Workstations. A limited finishing workstation shall comply with the applicable provisions of NFPA 33 and Sections 2404.4 through 2404.8.2.

Reason:

This proposed addition addresses a common type of spray application enclosure used in the finishing industry that is not currently addressed by the code. NFPA 33 includes definitions and the minimum safety requirements for this type of equipment.

Cost Impact

The code change proposal will not increase or decrease the cost of construction .

There is no cost impact due to this change. Equipment is currently built to meet the requirements of NFPA 33.

Internal ID: 2325

F230-18

IFC: 2404.4, 2404.5.2

Proponent: Jeffrey Hugo, National Fire Sprinkler Association, representing National Fire Sprinkler Association (hugo@nfsa.org)

2018 International Fire Code

Revise as follows:

2404.4 Fire protection. Spray booths and spray rooms shall be protected by an automatic sprinkler system or approved automatic fire-extinguishing system complying with Chapter 9. Protection shall extend to exhaust plenums, exhaust ducts and both sides of dry filters where such filters are used.

2404.5.2 Protection of sprinklers. Automatic sprinklers installed in *flammable vapor areas* shall be protected from the accumulation of residue from spraying operations in an *approved* manner. Bags used as a protective covering shall be 0.003-inch-thick (0.076 mm) ~~polyethylene or~~ cellophane or shall be thin paper. Automatic sprinklers contaminated by overspray particles shall be replaced with new automatic sprinklers.

Reason:

IFC Chapter 24 allows automatic sprinkler systems to protect spray operations. This defined term in added to 2404.4 to specify which fire protection systems can be installed. An approved fire-extinguishing system is permitted, but to leave the code with just this term in confusing as other areas allows sprinklers.

Poly bags were eliminated by NFPA 13 in the 2013 edition to protect sprinklers. Cellophane and thin paper are permitted and the fire code should not allow a material that voids the listing of the sprinkler.

Cost Impact

The code change proposal will not increase or decrease the cost of construction .

Poly, cellophane and paper bags are similar in cost, but poly bags prove in tests and post-fires to delay and obstruct sprinkler flow.

Internal ID: 811

F231-18

IFC: 2404.8.2, 2404.8.2.1 (New), 2404.8.2.2 (New), 2404.8.2.3 (New)

Proponent: Geoffrey Raifsnider, Global Finishing Solutions, representing Self

2018 International Fire Code

Revise as follows:

~~**2404.8.2 Ventilation interlock prohibited.** Air makeup and flammable vapor area exhaust systems shall not be interlocked with the fire alarm system and shall remain in operation during a fire alarm condition.~~

~~**Exception:** Where the type of fire extinguishing system used requires such ventilation to be discontinued, air makeup and exhaust systems shall shut down and dampers shall close.~~

The interlocking of ventilation with fire alarm systems shall be in accordance with Sections 2404.8.2.1 through 2404.8.2.3.

Add new text as follows:

2404.8.2.1 Interlock. Air makeup and flammable vapor area exhaust systems shall not be interlocked with the fire alarm system and shall remain in operation during a fire alarm condition.

2404.8.2.2 Recirculation. Where flammable vapor area exhaust is recirculated, the recirculation system shall shut down during any fire alarm condition.

Exception: Unless it can be demonstrated that shutting down the recirculation system would create a more hazardous condition.

2404.8.2.3 Shutdown. Where the type of fire-extinguishing system used requires such ventilation to be discontinued, air makeup, recirculation and exhaust systems shall shut down and dampers shall close.

Reason:

Addresses the operation of the recirculation portion of a spray booth or spray room during a fire alarm condition. Shutting down the recirculation prevents smoke from a fire within the spray area from being recirculated.

Cost Impact

The code change proposal will increase the cost of construction .

This code change may increase the cost of construction due to additional design features or mechanical equipment needed to shut down a recirculation system in a spray booth while keeping the supply and exhaust systems operational.

Internal ID: 2317

F232-18

IFC: TABLE 2704.2.2.1; IBC: [F] TABLE 415.11.1.1.1

Proponent: Lynne Kilpatrick, Sunnyvale Department of Public Safety, representing Sunnyvale Department of Public Safety (lkilpatrick@sunnyvale.ca.gov)

2018 International Fire Code

Revise as follows:

**TABLE 2704.2.2.1
QUANTITY LIMITS FOR HAZARDOUS MATERIALS IN A SINGLE FABRICATION AREA IN GROUP H-5a**

HAZARD CATEGORY		SOLIDS (pounds per square foot)	LIQUIDS (gallons per square foot)	GAS (cubic feet @ NTP/square foot)
PHYSICAL-HAZARD MATERIALS				
Combustible dust		Note b	Not Applicable	Not Applicable
Combustible fiber	Loose	Note b	Not Applicable	Not Applicable
	Baled	Notes b and c		
Combustible liquid	I	Not Applicable	0.01	Not Applicable
	IIA		0.02	
	IIB		Not Limited	
Combination Class	I, II and IIA		0.04	
Cryogenic gas	Flammable	Not Applicable	Not Applicable	Note d
	Oxidizing			1.25
Explosives		Note b	Note b	Note b
Flammable gas	Gaseous	Not Applicable	Not Applicable	Note d
	Liquefied			Note d
Flammable liquid	IA	Not Applicable	0.0025	Not Applicable
	IB		0.025	
	IC		0.025	
Combination Class	IA, IB and IC		0.025	
Combination Class	I, II and IIA		0.04	
Flammable solid		0.001	Not Applicable	Not Applicable
Organic peroxide	Unclassified detonable	Note b	Not Applicable	Not Applicable
	Class I	Note b		
	Class II	0.025		
	Class III	0.1		
	Class IV	Not Limited		
	Class V	Not Limited		
Oxidizing gas	Gaseous	Not Applicable	Not Applicable	1.25
	Liquefied			1.25
Combination of gaseous and liquefied				1.25
Oxidizer	Class 4	Note b	Note b	Not Applicable
	Class 3	0.003		
	Class 2	0.003		
	Class 1	0.003		
	Combination Class	1, 2, 3		
Pyrophoric materials		0.01	0.00125	Notes d and e
Unstable (reactive)	Class 4	Note b	Note b	Note b
	Class 3	0.025	0.0025	Note b
	Class 2	0.1	0.01	Note b
	Class 1	Not Limited	Not Limited	Not Limited
Water reactive	Class 3	Note b	0.00125	Not Applicable
	Class 2	0.25	0.025	
	Class 1	Not Limited	Not Limited	
HEALTH-HAZARD MATERIALS				
Corrosives		Not Limited	Not Limited	Not Limited
Highly toxic		Not Limited	Not Limited	Note d
Toxics		Not Limited	Not Limited	Note d

For SI: 1 pound per square foot = 4.882 kg/m², 1 gallon per square foot = 40.7 L/m², 1 cubic foot @ NTP/square foot = 0.305 m³ @ NTP/m², 1 cubic foot = 0.02832 m³.

- a. Hazardous materials within piping shall not be included in the calculated quantities.
- b. Quantity of hazardous materials in a single fabrication area shall not exceed the maximum allowable quantities per control area in Tables 5003.1.1(1) and 5003.1.1(2).
- c. Densely packed baled cotton that complies with the packing requirements of ISO 8115 shall not be included in this material class.
- d. The aggregate quantity of flammable, pyrophoric, toxic and highly toxic gases shall not exceed the greater of 0.2 cubic feet at NTP/square foot or 9,000 cubic feet at NTP.
- e. The aggregate quantity of pyrophoric gases in the building shall not exceed the amounts set forth in Table 5003.8.2.
- f. Quantity of Class 3 water reactive solids in a single tool shall not exceed 1 pound.

2018 International Building Code

[F] TABLE 415.11.1.1.1

QUANTITY LIMITS FOR HAZARDOUS MATERIALS IN A SINGLE FABRICATION AREA IN GROUP H-5^a

HAZARD CATEGORY		SOLIDS (pounds per square foot)	LIQUIDS (gallons per square foot)	GAS (cubic feet @ NTP/square foot)
PHYSICAL-HAZARD MATERIALS				
Combustible dust		Note b	Not Applicable	Not Applicable
Combustible fiber	Loose	Note b	Not Applicable	Not Applicable
	Baled	Notes b and c		
Combustible liquid	II	Not Applicable	0.01	Not Applicable
	IIA		0.02	
	IIIB		Not Limited	
Combination Class	I, II and IIA		0.04	
Cryogenic gas	Flammable	Not Applicable	Not Applicable	Note d
	Oxidizing			1.25
Explosives		Note b	Note b	Note b
Flammable gas	Gaseous	Not Applicable	Not Applicable	Note d
	Liquefied			Note d
Flammable liquid	IA	Not Applicable	0.0025	Not Applicable
	IB		0.025	
	IC		0.025	
Combination Class	IA, IB and IC		0.025	
Combination Class	I, II and IIA		0.04	
Flammable solid		0.001	Not Applicable	Not Applicable
Organic peroxide	Unclassified detonable	Note b	Not Applicable	Not Applicable
	Class I	Note b		
	Class II	0.025		
	Class III	0.1		
	Class IV	Not Limited		
	Class V	Not Limited		
Oxidizing gas	Gaseous	Not Applicable	Not Applicable	1.25
	Liquefied			1.25
Combination of gaseous and liquefied				1.25
Oxidizer	Class 4	Note b	Note b	Not Applicable
	Class 3	0.003		
	Class 2	0.003		
	Class 1	0.003		
	Combination Class	1, 2, 3		
Pyrophoric materials		0.01	0.00125	Notes d and e
Unstable (reactive)	Class 4	Note b	Note b	Note b
	Class 3	0.025	0.0025	Note b
	Class 2	0.1	0.01	Note b
	Class 1	Not Limited	Not Limited	Not Limited
Water reactive	Class 3	Note b <u>0.01</u>	0.00125	Not Applicable
	Class 2	0.25	0.025	
	Class 1	Not Limited	Not Limited	
HEALTH-HAZARD MATERIALS				
Corrosives		Not Limited	Not Limited	Not Limited
Highly toxic		Not Limited	Not Limited	Note d
Toxics		Not Limited	Not Limited	Note d

For SI: 1 pound per square foot = 4.882 kg/m², 1 gallon per square foot = 40.7 L/m², 1 cubic foot @ NTP/square foot = 0.305 m³ @ NTP/m², 1 cubic foot = 0.02832 m³.

- a. Hazardous materials within piping shall not be included in the calculated quantities.
- b. Quantity of hazardous materials in a single fabrication shall not exceed the maximum allowable quantities per control area in Tables 307.1(1) and 307.1(2).
- c. Densely packed baled cotton that complies with the packing requirements of ISO 8115 shall not be included in this material class.
- d. The aggregate quantity of flammable, pyrophoric, toxic and highly toxic gases shall not exceed the greater of 0.2 cubic feet at NTP/square foot or 9,000 cubic feet at NTP.
- e. The aggregate quantity of pyrophoric gases in the building shall not exceed the amounts set forth in Table 415.6.2.
- f. Quantity of Class 3 water reactive solids in a single tool shall not exceed 1 pound.

Reason:

As technological advances continue to be made an important and widespread process now being used is Metal Organic Chemical Vapor Deposition (MOCVD). This technology deposits multiple thin films on a semiconductor wafer using a metal-organic vapor. The tools that employ this technology have on-board ampoules of solid metal organics (e.g. trimethylaluminum, trimethylgallium) that are pyrophoric and Class 3 water-reactives. This proposal is to revise the total quantity of Class 3 water reactive solids allowed in a single H5 fabrication area from 1 lb. (aggregate) to 0.01 lb/sq.ft. while also limiting the maximum quantity of Class 3 water reactive solids on-board a single tool to 1 pound. This is an overall increase in an H5 occupancy that aligns with the quantity currently allowed for Class 3 water reactive liquids in a single fabrication area. The MOCVD process is considered a closed use system utilizing sealed ampoules or "bubblers" to prevent contact with water, UV/IR detection, fail-safe shut-offs and compliance with all other aspects of Chapter 27.

Cost Impact

The code change proposal will not increase or decrease the cost of construction .

This proposal only affects the quantity of Class 3 water reactive solids allowed in a single H5 fabrication area.

Internal ID: 2155

F233-18

IFC: 2808.3, 2808.3.1 (New), 2808.4

Proponent: Michael O'Brian, Chair, representing FCAC (fcac@iccsafe.org)

2018 International Fire Code

Revise as follows:

2808.3 Size of piles or stacks. Piles shall not exceed 25 feet (7620 mm) in height, 150 feet (45 720 mm) in width and 250 feet (76 200 mm) in length.

Exception: ~~The fire code official is authorized to allow the pile size to be increased where a fire protection plan is provided for approval that includes, but is not limited to, the following:~~

- ~~1. Storage yard areas and materials-handling equipment selection, design and arrangement shall be based on sound fire prevention and protection principles.~~
- ~~2. Factors that lead to spontaneous heating shall be identified in the plan, and control of the various factors shall be identified and implemented, including provisions for monitoring the internal condition of the pile.~~
- ~~3. The plan shall include means for early fire detection and reporting to the public fire department; and facilities needed by the fire department for fire extinguishment including a water supply and fire hydrants.~~
- ~~4. Fire apparatus access roads around the piles and access roads to the top of the piles shall be established, identified and maintained.~~
- ~~5. Regular yard inspections by trained personnel shall be included as part of an effective fire prevention maintenance program.~~

~~Additional fire protection called for in the plan shall be provided and shall be installed in accordance with this code. The increase of the pile size shall be based on the capabilities of the installed fire protection systems and features. Stackable products shall not be stacked in excess of 25 feet in height, 80 feet in width and 250 feet in length.~~

Add new text as follows:

2808.3.1 Increase in Pile or Stack size. Piles or stackable products are permitted to be increased beyond the dimensions in Section 2808.3 provided a written fire protection plan is approved by the fire code official. The fire protection plan shall include, but not be limited to, the following:

1. Contact information for after-hours response by facility personnel.
2. Storage yard areas and material-handling equipment selection, pile design and arrangement shall be based upon sound safety and fire protection principles.
3. Fire apparatus access roads around the piles or stacks and access roads to the top of piles if applicable shall be established, identified, and maintained.
4. The potential for spontaneous heating shall be evaluated and provisions made to control the temperature of the piles. Methods for monitoring the internal temperature of the pile shall be provided.
5. Routine yard inspections shall be conducted by trained personnel.
6. A means for early fire detection and reporting to the public fire department shall be provided.
7. Facilities and equipment needed by the fire department for fire extinguishment shall be provided, including a water supply in compliance with section 507 and heavy equipment necessary to move material.
8. A de-inventory plan shall be utilized to remove alternating piles or stacked products in a manner to increase the separation distances between the remaining piles or stacks.
9. The increased pile size shall be based upon the capabilities of the installed fire protection systems and features.
10. A controlled burn area shall be provided on the site for smoldering or damaged product.

Revise as follows:

2808.4 Pile separation. Piles or stacked product shall be separated from buildings, property lines and adjacent piles ~~by approved fire apparatus access roads~~, or stacks by a distance of not less than 1-1/2 times the height of the pile or stack. The distance between rows shall be a minimum of 30 feet . Approved fire apparatus access roads shall be provided within the separation space in accordance with Section 503.

Reason:

The code never anticipated stacked bales of biomass being used in an agro-industrialized fashion. The difference between piles and stacks was not clearly defined. Restrictions on pile sizes are established for good and practical reasons. When the piles are made low and narrow, fire extinguishment is enhanced and firefighter safety improved. When the piles are extremely high and wide, fire extinguishment is hampered and arrangements must be made for fire-fighting service. This section provides tools and guidance for fire code officials when proposals to increase pile size are submitted. The fire code official must realize these storage sites are not permanent and storage amounts are based upon when the product is harvested. Biomass fuels are likely to have larger storage sites in the fall and winter with declining inventory throughout the rest of the year as product is used.

In order to slow the spread of fire from pile to pile, as well as to provide the fire department with tactical access to all parts of the pile storage area, piles must be subdivided by fire apparatus access roads at least 20 feet in clear width at the base of the piles, in accordance with section 503.2.1. This proposal also protects firefighters who may be operating equipment between the stack rows of aging product. The UL test burns showed large sections of bales falling nearly 20 feet to the ground when fire burnt through the twine. Establishing a collapse zone around these structures is similar to building collapse zones for apparatus parking. Distance separation is based on firefighter safety and equipment operation. Future data may be available to revisit radiant heat as it relates to adjacent stacks.

This proposal is submitted by the ICC Fire Code Action Committee (FCAC). The FCAC was established by the ICC Board of Directors to pursue opportunities to improve and enhance assigned International Codes with regard to fire safety and hazardous materials in new and existing buildings and facilities and the protection of life and property in wildland urban interface areas. In 2017 the Fire-CAC has held 3 open meetings. In addition, there were numerous conference calls, Regional Work Group and Task Group meetings for the current code development cycle, which included members of the committees as well as any interested parties, to discuss and debate the proposed changes. Related documentation and reports are posted on the FCAC website at: <https://www.iccsafe.org/codes-tech-support/cs/fire-code-action-committee-fcac/>

Cost Impact

The code change proposal will decrease the cost of construction .

The product of Biomass fuels (baled switch grass or corn stover) is already being stacked. If there is a cost impact it may be related to storage site leases. Many companies lease land in fields to store biomass. The current 2018 code limits the size of piles to 250 feet in length. Many storage sites are several hundred feet in length with rows separated by as little as 15 feet. The proposal to increase the length of piles (stacks) can be approved if all the criteria are met listed in 2808.3.1. If extended, it may reduce the amount of land needed to be leased since the exceptions call for increased size of piles but added fire safety features to prevent conflagrations of stover piles.

Internal ID: 263

F234-18

IFC: TABLE 315.7.6(1), SECTION 2810, 2810.1, 2810.2, 2810.3, 2810.4, 2810.5, 2810.6, 2810.7, 2810.8, 2810.9, 2810.10, 2810.11

Proponent: Michael O'Brian, Chair, representing FCAC (fcac@iccsafe.org)

2018 International Fire Code

Revise as follows:

**TABLE 315.7.6(1)
SEPARATION DISTANCE BETWEEN WOOD PALLET STACKS AND BUILDINGS**

WALL CONSTRUCTION	OPENING TYPE	WOOD PALLET SEPARATION DISTANCE (feet)		
		≤ 50Pallets	51 to 200Pallets	> 200Pallets
Masonry	None	2	2	2
Masonry	Fire-rated glazing with open sprinklers	2	5	20
Masonry	Fire-rated glazing	10 <u>5</u>	5 <u>10</u>	20
Masonry	Plain glass with open sprinklers	10 <u>5</u>	5 <u>10</u>	20
Noncombustible	None	10 <u>5</u>	5 <u>10</u>	20
Wood with open sprinklers	—	10 <u>5</u>	5 <u>10</u>	20
Wood	None	15	30	90
Any	Plain glass	15	30	90

For SI: 1 foot = 304.8 mm.

SECTION 2810 OUTDOOR STORAGE OF PALLETS AT PALLET MANUFACTURING AND RECYCLING FACILITIES

2810.1 General. The outside storage of wood pallets and wood composite pallets on the same site as a pallet manufacturing or pallet recycling facility shall comply with Sections 2810.2 through 2810.11.

2810.2 Site plan. Each site shall maintain a current site ~~plan that includes a general description of the property, the boundaries of the lot, the size and location of buildings,~~ plan. The site plan be submitted to the fire code official and approval and all of the following:

1. Lot Lines
2. Utilities.
3. Type, Size, location, and type of construction and presence of sprinkler protection for other of the buildings on the site, property
4. Presence of fire protection systems
5. Water supply sources for fire-fighting purposes.
6. Location of hazardous material storage areas.
7. Location of pallet storage.
8. Equipment protected with a dust collection system.
9. *Fire apparatus access roads.*
10. Designated smoking areas.
11. Location of fire alarm control panels.

2810.3 Fire prevention plan. The *owner* or *owner's* authorized representative shall ~~prepare an approved~~ submit a fire prevention plan for review and approval by the fire code official that includes all of the following:

1. Frequency of walk-through inspections to verify compliance with the plan.
2. Hot work permit program in accordance with Chapter 35.
3. Preventive maintenance program for equipment associated with pallet activities.
4. Inspection, testing and maintenance of *fire protection systems* in accordance with Chapter 9.

2810.4 Fire safety and ~~emergency evacuation~~ plan. The *owner* or *owner's* authorized representative shall prepare and train employees in an *approved* fire safety and ~~emergency~~ evacuation plan in accordance with Chapter 4.

2810.5 Security management plan. The *owner* or *owner's* authorized representative shall prepare a security management plan based on a security risk assessment and shall make the plan and assessment available to the *fire code official* upon request.

2810.6 Clearance to property line. Stacks of pallets shall not be stored within 0.75 times the stack height or 8 feet (2438 mm) of the property line, whichever is greater, or shall comply with Section 2810.11.

2810.7 Clearance to important buildings. Stacks of pallets shall not be stored within 0.75 times the stack height of any important building on site, or shall comply with Section 2810.11.

2810.8 Height. Pallet stacks shall not exceed 20 feet (6096 mm) in height.

2810.9 Fire flow. Fire-flow requirements for the site shall be determined by the *fire code official*.

2810.10 Portable fire extinguishers. Portable fire extinguishers shall be ~~provided within 75 feet (22 860 mm) of any pallet stack selected,~~ installed and maintained in accordance with Section 906.

2810.11 Alternative approach. Where *approved* by the *fire code official*, pallet stacks are permitted to be located closer to a property line or structure than as required by Sections 2810.6 and 2810.7 ~~shall be provided with,~~ where additional fire protection is provided, including, but not limited to, the following:

1. The storage yard areas and materials-handling equipment selection, design, and arrangement are

based on an *approved* risk assessment.

2. Automatic fire detection that transmits an alarm to a supervising station in accordance with NFPA 72.
3. *Fire apparatus access roads* around all storage areas.

Reason:

This pallet proposal is to address two items from the previous cycle. The first part of the proposal is to address an issue that happened when the original proposal was submitted into cdpACCESS and a couple of numbers were reversed. This proposal will correct this mistake. The second part of the proposal contains some necessary edits to the language and provides better language flow and to provide more appropriate code format. Both of these revisions were promised to the previous committee that if the proposal passed we would bring these changes and corrections back to the next hearing. This code change meets fulfills that promise.

This proposal is submitted by the ICC Fire Code Action Committee (FCAC). The FCAC was established by the ICC Board of Directors to pursue opportunities to improve and enhance assigned International Codes with regard to fire safety and hazardous materials in new and existing buildings and facilities and the protection of life and property in wildland urban interface areas. In 2017 the Fire-CAC has held 3 open meetings. In addition, there were numerous conference calls, Regional Work Group and Task Group meetings for the current code development cycle, which included members of the committees as well as any interested parties, to discuss and debate the proposed changes. Related documentation and reports are posted on the FCAC website at: <https://www.iccsafe.org/codes-tech-support/cs/fire-code-action-committee-fcac/>

Cost Impact

The code change proposal will not increase or decrease the cost of construction .

This fixes incorrect distances and provides clarification to the section overall and will likely make compliance less expensive.

Internal ID: 371

F235-18

IFC: 2810.4

Proponent: Kevin Scott, representing KH Scott & Associates LLC (khscottassoc@gmail.com)

2018 International Fire Code

Revise as follows:

2810.4 Fire safety and ~~emergency evacuation plan~~. The *owner* or *owner's* authorized representative shall prepare and train employees in an *approved* fire safety and ~~emergency~~ evacuation plan in accordance with Chapter 4.

Reason:

This is a revision to correlate the terminology in this section with the referenced plan in Chapter 4. Section 403.2 through 403.11.5 require "fire safety and evacuation plans".

Cost Impact

The code change proposal will not increase or decrease the cost of construction .

Correlation of terminology; there is no change on requirements.

Internal ID: 2336

F236-18

IFC: 3006.1

Proponent: Ellie Klausbruckner, Klausbruckner & Associates Inc., representing Klausbruckner & Associates, Inc. (ek@klausbruckner.com)

2018 International Fire Code

Revise as follows:

3006.1 Required protection. Class A and B ovens that contain, or are utilized for the processing of, combustible materials shall be protected by an *approved automatic fire-extinguishing system* complying with Chapter 9.

Exceptions:

1. Small tabletop ovens used in laboratory facilities.
2. Non walk-in ovens that are less than 4 feet (1.22 m) in length and width.

Reason:

The section is intended for large furnaces, but based on the definitions of Class A and B ovens, sprinklers are required inside smaller and portable ovens. The 4 ft dimension is in line with NFPA 13 requirements for sprinklering below obstructions and can be used as a relative size above which sprinklers would be required.

Cost Impact

The code change proposal will decrease the cost of construction .

The proposal allows exceptions for sprinklered smaller ovens and therefore reduces cost to construction.

Internal ID: 1622

F237-18

IFC: 3103.3.1

Proponent: Kevin Scott, representing KH Scott & Associates LLC (khscottassoc@gmail.com)

2018 International Fire Code

Revise as follows:

3103.3.1 Special amusement building. Tents and other membrane structures erected as a special amusement building shall be equipped with an *automatic sprinkler system* in accordance with Section ~~411.3 of the International Building Code~~ 914.7.1.

Reason:

The current language refers back to Section 411.3 in the IBC. IBC Section 411.34 is copied from the IFC and the exact same language can be found in IFC Section 914.7.1. In fact, the IBC section shows “[F]” at the start of the section.

This proposal is to simply refer to the original text for the requirement, which is IFC Section 914.7.1.

There is no change in application or enforcement, however, it eliminates the potential confusion about whether the IBC language applies to the temporary special amusement building.

Cost Impact

The code change proposal will not increase or decrease the cost of construction .

There is no change in application or enforcement of the requirements.

Internal ID: 2308

F238-18

IFC: 3103.9, 3103.9.1, Table 3103.9.1 (New), 3103.9.2, 3103.9.3, Chapter 80, ordinal

Proponent: Thomas Markel, representing Industrial Fabrics Association International - Tent Rental Division; Paul Armstrong, representing IFAI (paul@paulandvauna.com)

2018 International Fire Code

3103.9 Structural stability and anchorage required. Tents or membrane structures and their appurtenances shall be designed and installed to withstand the elements of weather and prevent collapsing. Documentation of structural stability shall be furnished to the *fire code official*.

Revise as follows:

~~3103.9.1 Tents and membrane structures greater than one story. Structural requirements.~~ Tents and membrane structures, exceeding one story, or an occupant load of 1,000 or greater or floor area greater than 15,000 square feet, shall be designed and constructed to comply with Sections 1606 through ~~1609-1608~~ of the International Building Code. Tent and membrane structures shall comply with Table 3103.9.1 for wind loads

Exceptions:

1. Tents and membrane structures installed for 180 consecutive days or more shall comply with Section 1609 of the International Building Code for wind loads.
2. Special Event Structures complying with Section 3105.

Add new text as follows:

Table 3103.9.1
Minimum Design Wind Loads and Documentation

	<u>Duration of Exposure in Days^a</u>	<u>1 - 7</u>	<u>8 - 30</u>	<u>31 - 179</u>
<u>Occupant Load^g</u>	<u>Floor Area (sq ft)^g</u>	<u>Minimum Design Wind Speed (mph)^{b, c}</u>		
<u>10 - 49^d</u>	<u>800 or less^d</u>	<u>57</u>	<u>65</u>	<u>70</u>
<u>50 - 299^e</u>	<u>801 - 5,000^e</u>	<u>65</u>	<u>70</u>	<u>77</u>
<u>300 - 999^e</u>	<u>5,001 - 15,000^e</u>	<u>70</u>	<u>77</u>	<u>83</u>
<u>1,000 & over^f</u>	<u>15,001 or greater^f</u>	<u>77</u>	<u>83</u>	<u>89</u>
<u>All^f</u>	<u>Exceeding one story^f</u>	<u>83</u>	<u>89</u>	<u>96</u>

- a. Duration of Occupancy except installation and/or removal unless on the same day.
- b. Minimum design wind speed for ASCE 7 wind pressure for Occupancy Category II.
- c. Wind speed 3 second gust at 33ft elevation for Exposure C.
- d. Anchorage plan by Owner, Agent or Installer, based on; Manufacturer's or Registered Design Professional documentation or use 10 lbs per square foot ground surface uplift divided equally between anchor points.
- e. Anchorage plan by Owner, Agent or Installer based on Manufacturer's or Registered Design Professional documentation for Exposure C.
- f. Site specific analysis and anchorage plan from a Registered Design Professional.
- g. For occupancies A-1 to A-4, B, E, M & S-1 to S-2 for aggregate of either occupant load or floor area.

Delete without substitution:

~~**3103.9.2 Tents and membrane structures greater than 7,500 square feet.** *Tents and membrane structures greater than 7,500 square feet (697 m²) shall be designed and constructed to comply with Sections 1606 through 1609 of the International Building Code.*~~

~~**3103.9.3 Tents and membrane structures with an occupant load greater than 1,000.** *Tents and membrane structures with an occupant capacity greater than 1,000 persons shall be designed and constructed to comply with Sections 1606 through 1609 of the International Building Code.*~~

Add new standard(s) follows:

CHAPTER 80 REFERENCED STANDARDS

Update standard(s) as follows:

ASCE/SEI

American Society of Civil Engineers
Structural Engineering Institute
Reston VA 20191-4400

ASCE 7-16:

Minimum Design Load and Associated Criteria for Buildings and Other Structures

Reason:

Overview

In recent years a number of accidents involving temporary tents have resulted in injuries and deaths. Some tents had no wind "ratings" and therefore had no documentation, others were "rated" yet installed improperly. These accidents generally involved failure of the anchoring caused by wind loads leading to the accident. Previous code changes suggested a simple all or nothing approach, however some of these accidents would have still occurred with this approach and the cost to other events would have exceeded their capacity to fund with little actual gain in public safety since equipment being used already had documentation.

Design Wind Speed

The design wind speed in ASCE 7 for permanent structures is based on a 50 year return period. The commentary of ASCE 7 contains the formula that defines the probability that the design wind speed will be exceeded during a specific time period:

$$P_n = 1 - (1 - P_a)^n \text{ (C26.5-7)}$$

Apply this for n = 50 years, the result is a probability of 0.64 for the design wind speed to be exceeded during a 50 year return period.

It is common in current engineering practice to use the same probability for shorter exposure periods, to determine a reduced design wind speed for structures that are temporary in nature. Because there is no standard defining what values to use, the values currently used depend upon the engineer's and the code officials' judgement. The goal with the proposed table is to define a common set of numbers that everyone uses.

In the current practice the wind speed is reduced to equate a return period generally between 2 to 5 years, depending on judgement. The reasons that longer periods are chosen compared to the actual exposure for a tent, are as follows:

1. Tents are installed multiple times so it is reasonable to use a longer exposure period than just the installation

period for one single event or project.

2. For short exposure periods, the resulting design wind speed would be too low to make sense from an evacuation and public safety standpoint.

In the same commentary in ASCE 7 there is a formula to convert the 50 year return period to other return periods:

$$VT/V50 = (0.36 + 0.1 \ln(12T)) \quad (C26.5-2)$$

The following are the design wind speeds for the different return periods based on this formula:

As example: for a 2 year return period this formula results in a ratio of 0.6778 or a design wind speed of $0.6778 \times 115 \text{ mph} = 78 \text{ mph}$.

<u>Period</u>	<u>MPH</u>	<u>Period</u>	<u>MPH</u>
6 month	62	2.5 year	81
1 year	70	3 year	83
1.5 year	75	5 year	89
2 year	78	10 year	96

The probability for a design wind speed to be exceeded during a specific period is based on what society accepts as risk and as acceptable balance between the need for public safety and the cost associated with requiring higher levels of safety. Given the acceptable risk for permanent structures which is well established, it is rational to accept a similar concept for temporary structures.

Comparing the proposed Table 3103.9.1 with the return wind speeds above one notices that the 2 year period was chosen as the middle number in the table, 8 - 30 days and the middle row, 300- 999 occupancy/ 5,001 - 15,000 sq ft size. The other values in the middle column (8-30 days) are chosen to decrease the return period on smaller and increase on larger occupancies and sizes.

The smallest tent for the shortest exposure period has a minimum design wind speed of 57 mph, while the largest tent with the longest exposure is 89 mph, equivalent to a 10 year return period.

Tents exceeding one story are subject to higher design wind speeds in the proposed tables because a failure of a floor level exposes occupants to additional risks both on spaces below and above compared to a tent that is only a roof.

For larger tents, the proposed table will result in higher wind design requirements vs the current practice for the largest tents and longer period of exposure. Many large tent currently meet the 78 mph / 2 year return period.

For smaller tents, the proposed table will for the first time establish minimum design wind speed requirements, and as such is a major commitment of the tent manufacturing and rental industry to public safety.

While we recognize that the table creates a level of complexity not currently in the IFC, we believe it is justifiable because it will allow enforcement of a set of rules that are, though challenging, obtainable for the tent industry and for users of temporary tents in general.

Documentation Requirements

The documentation requirements associated with the proposal are based on 3 different levels, whereby the requirements become more stringent for larger occupancies / sizes. The reason for basing it both on occupancy and size is that there are applications for temporary tents where there is little to no occupancy but where a reasonable level of safety is still needed in the public interest.

The lowest level is footnote 4: it requires an anchoring plan that is either based on a generic wind load documentation from a manufacturer or registered design professional or based on a generally conservative formula requiring resistance against 10 psf uplift equally divided over all anchor points.

Footnote 5: anchorage based on generic engineering documentation provided by the manufacturer or a registered design professional. This requires design wind speed documentation in a category where currently most tents have no wind speed or anchoring load information.

The highest level is Footnote 6: site specific engineering documentation by a registered design professional, which takes into account the specific circumstances of the site: wind exposure, hill, exact length, and anchoring at the site.

Similar as for the design wind speed, we believe it is rational to have a graduated series of documentation requirements to find a balance between public safety and expenses that are reasonable compared to the economics of the project as opposed to a none or all approach.

Occupancies

The minimum wind design requirements in Table 3103.9.1 are based on certain occupant categories. Ones that need

greater oversight, like Group H, would require a registered design professional and code official review, even for temporary use. These are a minority of installations, but the hazards of Group H extend well beyond the structure or Groups I & R for the difficulty in evacuation.

Exceptions in 3103.9.1

Exception 1: Tents and membrane structures that are installed for more than 180 days are subject to the full wind load criteria found in the IBC Section 1609 based on this exception. IBC Sections 1601 thru 1609 are also imposed.

Exception 2: Special Event structures regulated in 3105 should be exempted from this compliance structure. They are not exempt from any compliance, rather they are to conform to the ANSI E1.21 standard as required in 3105. These structures, their usage, designs and load vary far more than temporary tents. They have staff on site, and can design outdoor structures with wind mitigation, where most tent installations, provided by rental companies, have no personnel on site during use.

Summary

No standard or code can prevent all accidents. If this code change were being enforced during recent occurrences a number of accidents would have been prevented. The table establishes minimums that should be used by event promoters, owner and agents for Operational Management Plans including High Wind Action Plans.

With the goal of increasing public safety with reasonable and enforceable requirements and methods, the proposed code changes with inclusion of Table 3103.9.1 will accomplish this. Although costs of equipment, permits and installations will rise, by using a tiered approach, a level of safety will be achieved at all occupancy and tents sizes for events with achievable level of documentation and cost.

Cost Impact

The code change proposal will increase the cost of construction .

Cost increases will include manufacturers or design professional documentation for tents currently without any. Owners or installers will have to prepare anchoring plans for permit submissions based on the tent site's soil conditions, not currently done for most installations. However, the use of generic plans for similar soil conditions will be acceptable.

Internal ID: 530

F239-18

IFC: 3103.9.1, 3103.9.2, 3103.9.3

Proponent: Richard Nix, representing Entertainment Services & Technology Association/Event Safety Alliance (rnix@zoomtown.com)

2018 International Fire Code

Revise as follows:

3103.9.1 Tents and membrane structures greater than one story. Tents and membrane structures exceeding one story shall be designed and constructed to comply with Sections ~~1606-1603~~ through 1609 of the International Building Code.

3103.9.2 Tents and membrane structures greater than 7,500 square feet. *Tents and membrane structures* greater than 7,500 square feet (697 m²) shall be designed and constructed to comply with Sections ~~1606-1603~~ through 1609 of the International Building Code.

3103.9.3 Tents and membrane structures with an occupant load greater than 1,000. *Tents and membrane structures* with an occupant capacity greater than 1,000 persons shall be designed and constructed to comply with Sections ~~1606-1603~~ through 1609 of the International Building Code.

Reason:

This change proposal captures the complete design requirements necessary for an appropriate structural review, and further enhances the IFC submittal document requirements by ensuring proper information is included for the benefit of pre-construction permit review and for any onsite inspections that also may be required, after construction permit approval.

Adding the reference to 1603 correlates with the construction document requirements of the IFC, and ensures wind design data is included in the construction documents. This information is necessary for structural design of the main wind force resisting system.

Adding the reference to 1604 clarifies the necessary design requirements, including risk categories, etc. but even more important, it specifically includes anchorage requirements essential to design of temporary structures.

Reference to 1605 clarifies the necessary design load combinations that should be considered for all structures, but especially for temporary structures where weather-related events can be most destructive.

Special events using structures of any type create special considerations for life-safety requirements due to the event duration. Structural considerations have been commonly overlooked, and code officials often ask for better or more direct links to the building code with respects to structural safety for temporary structures. This proposal addresses those requests.

Failure in the lateral force resisting system is a primary cause of temporary structure failure, but failures also occur as a result of improper ballasting/anchorage to resist uplift and overturning. For temporary structures, these failures are typically caused by weather-related events, usually wind. It is not acceptable to the entertainment and special event production industry that there are no clearly established structural requirements for temporary structures in the codes, especially since time and time again we are reminded how dangerous wind events can be in the context of temporary structures at special events. It is necessary to know the structure's capacity, particularly for wind loads, when used outdoors for temporary special events, so that mitigation actions and/or evacuation actions can be performed at wind speeds below the structure's capacity, and at wind speeds low enough to permit safe crowd movement during evacuation times.

Requiring that this information be included for temporary structures whenever IBC Chapter 16 is referenced, and whenever construction documents are required, helps ensure a) that proper design analysis has been done, b) that critical information about lateral force resisting systems and for anchorage systems are available during the permit review process, and c) that such information is available to on-site inspectors when inspections are required in addition to the pre-event construction permit submittal process.

Cost Impact

The code change proposal will not increase or decrease the cost of construction .

This code change will result in no change to construction costs because the structural analysis requirements already exist. Adding these (3) sections of IBC Chapter 16 clarifies the requirements, and ensures that complete information is provided for the construction permit submittal and review. Because inspections (when required) rely on information provided on the construction documents, this change may decrease the cost of construction by helping to alleviate

confusion during inspections by ensuring that complete information essential to the inspection process is provided well in advance of the actual inspection.

Internal ID: 1633

F240-18

IFC: 3103.9.2, 3103.9.3

Proponent: Richard Nix, representing Entertainment Services & Technology Association/Event Safety Alliance (rnix@zoomtown.com)

2018 International Fire Code

Delete without substitution:

~~**3103.9.2 Tents and membrane structures greater than 7,500 square feet.** *Tents and membrane structures greater than 7,500 square feet (697 m²) shall be designed and constructed to comply with Sections 1606 through 1609 of the International Building Code.*~~

~~**3103.9.3 Tents and membrane structures with an occupant load greater than 1,000.** *Tents and membrane structures with an occupant capacity greater than 1,000 persons shall be designed and constructed to comply with Sections 1606 through 1609 of the International Building Code.*~~

Reason:

Section 3103.6 **Construction documents** already includes structural analysis as part of construction document requirements for tents and membrane structures having an occupant load of 50 or more persons. This code change proposal alleviates confusion regarding potentially conflicting requirements.

Cost Impact

The code change proposal will not increase or decrease the cost of construction .

Construction documents and structural analysis are already required by other sections of this Chapter, so eliminating a redundant requirement has no effect on construction costs.

Internal ID: 1635

F241-18

IFC: 3103.10.2, Chapter 80

Proponent: Richard Nix, representing Entertainment Services & Technology Association/Event Safety Alliance

2018 International Fire Code

Revise as follows:

3103.10.2 Fabric envelope design and construction. ~~Air-supported and air-inflated structures shall have the design and construction of the fabric envelope and the method of anchoring in accordance with Architectural Fabric Structures Institute FSAAS.~~ be designed in accordance with ASCE/SEI 55-16.

Add new standard(s) follows:

ASCE/SEI

American Society of Civil Engineers
Structural Engineering Institute
Reston VA 20191-4400

ASCE/SEI 55-16:

Tensile Membrane Structures

Reason:

This code change proposal replaces outdated or obsolete references with an approved consensus-based reference standard, and removes redundant requirements already addressed in other sections.

These structures are within the scope of ASCE 55-16, which also addresses fabric structures regardless if the fabric is dependent or independent of a frame of any type. Anchorage requirements for all tent and membrane structures are already addressed as part of construction document requirements of Section 3103.6 and the structural stability/anchorage requirements of Section 3103.9.

A scope overview of ASCE/SEI 55-16 can be viewed online, at this web address:
<http://www.asce.org/templates/publications-book-detail.aspx?id=22498>

Cost Impact

The code change proposal will not increase or decrease the cost of construction .

The requirement to provide appropriate design already exists, so replacing obsolete documents with new standards improves and clarifies design requirements without increasing cost of construction.

Analysis: ASCE 55 is already referenced in the IBC. This is simply a new occurrence of the reference in the I-Codes

Internal ID: 1638

F242-18

IFC: 3104.2

Proponent: Michael O'Brian, Chair, representing FCAC (FCAC@iccsafe.org)

2018 International Fire Code

Revise as follows:

3104.2 Flame propagation performance ~~treatment, testing and certification.~~ Before a permit is granted, the *owner* or agent shall file with the *fire code official* a certificate ~~executed~~issued by an *approved* testing laboratory. The certificate shall indicate that the floor coverings, tents, membrane structures and their appurtenances, which include sidewalls, drops and tarpaulins, are composed of materials meeting the flame propagation performance of Test Method 2 of NFPA 701. Additionally, it shall indicate that the bunting and combustible decorative materials and effects are composed of material meeting the flame propagation performance criteria of Test Method 1 or Test Method 2 of NFPA 701, as applicable. Alternatively, the materials shall be treated with a flame retardant in an *approved* manner and meet the flame propagation performance criteria of the applicable test method of NFPA 701. The certificate shall indicate compliance with the testing requirements of Chapter 16 of NFPA 701. The flame propagation performance criteria shall be effective for the period specified by the permit.

Reason:

This proposal is a minor change to correct the requirements for testing and certification to NFPA 701 for weathering. Tents are typically used outdoors and therefore exposed to weather, especially rain. NFPA 701 has a chapter 16, entitled "Cleaning and Water Leaching Procedures", which contains procedures for accelerated dry cleaning, accelerated laundering and accelerated water leaching procedure when they have been conducted. This new requirement simply gives the fire code official the information needed to ensure compliance with the necessary testing procedures.

At present, the IFC does not require that the label indicate the materials tested for flame propagation performance where condition for outdoor use as covered in NFPA Chapter 16 for accelerated dry cleaning, accelerated laundering and accelerated water leaching procedures when they have been conducted. This new requirement simply gives the fire code official the information needed to ensure compliance with the necessary testing procedures.

This proposal is submitted by the ICC Fire Code Action Committee (FCAC). The FCAC was established by the ICC Board of Directors to pursue opportunities to improve and enhance assigned International Codes with regard to fire safety and hazardous materials in new and existing buildings and facilities and the protection of life and property in wildland urban interface areas. In 2017 the Fire-CAC has held 3 open meetings. In addition, there were numerous conference calls, Regional Work Group and Task Group meetings for the current code development cycle, which included members of the committees as well as any interested parties, to discuss and debate the proposed changes. Related documentation and reports are posted on the FCAC website at: <https://www.iccsafe.org/codes-tech-support/cs/fire-code-action-committee-fcac/>

Cost Impact

The code change proposal will not increase or decrease the cost of construction .

This is a clarification proposal that ensure the weather testing requirements in NFPA 701 are performed on all tents intended for outdoor use. This requirement is already in the 2018 IFC.

Internal ID: 256

F243-18

IFC: 3104.2, 3104.3, 3104.4

Proponent: Thomas Markel, representing Industrial Fabrics Association International - Tent Rental Division; Paul Armstrong, representing IFAI (paul@paulandvauna.com)

2018 International Fire Code

Revise as follows:

3104.2 Flame propagation performance treatment. Before a permit is granted, the *owner* or agent shall file with the *fire code official* a certificate executed by the product manufacturer certifying the materials have been tested by an approved testing laboratory. The certificate shall indicate that the floor coverings, tents, membrane structures and their appurtenances, which include sidewalls, drops and tarpaulins, are composed of materials meeting the flame propagation performance of Test Method 2 of NFPA 701. Additionally, it shall indicate that the bunting and combustible decorative materials and effects are composed of material meeting the flame propagation performance criteria of Test Method 1 or Test Method 2 of NFPA 701, as applicable. Alternatively, the materials shall be treated with a flame retardant in an *approved* manner and meet the flame propagation performance criteria of the applicable test method of NFPA 701. The flame propagation performance criteria shall be effective for the period specified by the permit.

3104.3 Label. Membrane structures or tents shall have a permanently affixed label bearing the identification of size and fabric or material ~~type~~ in addition to information required in Section 3104.4 of this Chapter.

3104.4 Certification. An affidavit or affirmation shall be submitted to the *fire code official* and either a copy retained on the premises on which the tent or air-supported structure is located, located or label affixed to the tent or air supported structure. The affidavit shall attest ~~to all of the~~ following information relative to the flame propagation performance criteria of the fabric:

1. Names and address of the ~~owners~~ manufacturers of the tent or air-supported structure.
2. ~~Date~~ Either with the date the fabric was last treated with flame-retardant ~~solution~~ solution, the
3. ~~trade~~ Trade name or kind of chemical used in ~~treatment~~ treatment,
4. ~~name~~ Name of person or firm treating the ~~material~~ material and
5. ~~name~~ Name of testing agency and test standard by which the fabric was ~~tested~~ tested, or
3. The material meets NFPA 701 test Method 1 or 2 without treatment.

Reason:

Tents and membrane structures have been labeled and certifications provided for decades since the Hartford circus fire. At the time of the fire tent material was a natural fiber and waterproofing was accomplished with a flammable mixture. After the fire a external flame retardant was required to be applied to retard flame spread. The topical application was subject to weather and cleaning and would degrade over time and exposure. Retreatment and retesting was needed for compliance.

With the availability of polyester or PVC based material, that has flame retardant integrated into the raw material before extrusion, external treatment of material is not required. The flame retardant is capable of performing for the life of the material and cannot be washed or weathered away. Also, "field testing" (NFPA 705) the tent or membrane structure by cutting out sections for testing, damages the membrane and degrades the structural integrity of the material increasing the danger to the public for a structural failure.

This code proposal changes three parts of the flame propagation requirement that are interrelated.

Flame propagation (3104.2): Testing agencies have never issue the label or certification of the assembled product, rather they test and document the materials used in assembly. The affixed label and certification provided for permitting have **always** been provided by the manufacturer (see attachments). This change to flame propagation corrects the code to what has been the acceptable practice for generations. Further it would be impossible and impractical to enforce the current code; for testing agencies are not capable of producing the label and certification documentation for every tent and sidewall produced by a manufacturer, nor are they able to trace the chain of custody of the materials as the manufacturer's have been doing as evident in both the certifications and labels (see attachments). Therefore this change only brings the code in line with what has been acceptable practice.

Labeling (3104.3): The code is very general and viewing the attached labels, the information presented varies widely. By tying the information required for the label to "match" the certification documentation aids the fire code official to insure the installation matches the permit documents.



Certification (3104.4): This change brings the code requirements of documentation up-to-date with modern tent and membrane structure manufacturing. Rarely is a natural fiber used in new product manufacturing. However, use of older tents made from natural fibers still occurs. The change in certification reflects the modern use of polyester and PVC material (new #3) whose flame retardant is now integrated in the raw polyester or PVC before extruded into material, and therefore cannot be washed or weathered away as the topical application method used on natural fibers.

IMPORTANT DOCUMENT
Certificate of Flame Resistance

REGISTRATION APPLICATION NUMBER: []

ISSUED BY: **ANCHOR INDUSTRIES INC.**

EVANSVILLE, INDIANA 47725

MANUFACTURERS OF THE FINISHED TENT PRODUCTS DESCRIBED HEREIN

THIS IS TO CERTIFY THAT THE MATERIALS DESCRIBED HAVE BEEN FLAME-RETARDANT TREATED BY AN INHERENTLY NONINFLAMMABLE AND WERE SUPPLIED TO:

1204
 FATHER CREATIONS LTD
 ONE BRAVO EVENTS - THE FLORIST
 71 PARK ST
 BUFFALO NY 14201

Certification is hereby made that:
 The articles described on this Certificate have been treated with a flame-retardant approved chemical and that the application of said chemical was done in conformance with California Fire Marshal Code, All fabric has been tested and passes NFPA 701-95, CPAI 84, ULC 109.

Serial # []

Description of item certified: []

Flame Retardant Process Used Will Not Be Removed By Washing And Is Effective For The Life Of The Fabric

Name of Applicator of Flame Retardant Process: []

Signed: [Signature] ANCHOR INDUSTRIES INC.

IMPORTANT DOCUMENT
Certificate of Flame Resistance

REGISTRATION APPLICATION NUMBER: []

ISSUED BY: **ANCHOR INDUSTRIES INC.**

EVANSVILLE, INDIANA 47725

MANUFACTURERS OF THE FINISHED TENT PRODUCTS DESCRIBED HEREIN

Date of Shipment: []

Item Identification: []

THIS IS TO CERTIFY THAT THE MATERIALS DESCRIBED HAVE BEEN FLAME-RETARDANT TREATED (or are inherently noninflammable) and were supplied to:

1204
 FATHER CREATIONS LTD
 ONE BRAVO EVENTS - THE FLORIST
 71 PARK ST
 BUFFALO NY 14201

Certification is hereby made that:
 The articles described on this Certificate have been treated with a flame-retardant approved chemical and that the application of said chemical was done in conformance with California Fire Marshal Code, All fabric has been tested and passes NFPA 701-95, CPAI 84, ULC 109.

Serial # []

Description of item certified: []

Flame Retardant Process Used Will Not Be Removed By Washing And Is Effective For The Life Of The Fabric

Name of Applicator of Flame Retardant Process: []

Signed: [Signature] ANCHOR INDUSTRIES INC.

IMPORTANT DOCUMENT
Certificate of Flame Resistance

Registration Number
F140.1



Date of Shipment
05/20/11

Tent Identification
14950431

MANUFACTURERS OF THE FINISHED TENT PRODUCTS DESCRIBED HEREIN

This is to certify that the materials described have been flame-retardant treated (or are inherently nonflammable) and were supplied to:

BRAVO EVENTS THE FLORISTRY
DBA BRAVO EVENTS - THE FLORISTRY
71 PARK ST
BUFFALO, NY 14201



Certification is hereby made that:

The articles described on this Certificate have been treated with a flame-retardant approved chemical and that the application of said chemical was done in conformance with California Fire Marshall Code. All fabric has been tested and passes NFPA 701-04, ULC 109.

Serial #
#152310 (1)

Description of item certified:
CENTURY END 80WX20 LOOP SNYDER
WHITE VL W/O WEB GUYS 10'5P

**Flame Retardant Process Used Will Not Be Removed By
Washing And Is Effective For The Life Of The Fabric**

SNYDER MFG NEW PHILADELPHIA, OH
Name of Applicator of Flame Resistant Finish

Signed: 
ANCHOR INDUSTRIES INC

This is to certify that the materials described below have been flame-retardant treated (or are inherently nonflammable)

FOR

Bravo Events Expos Displays
71 Park Street
Buffalo, NY 14201

Certification is hereby made that: (Check "a" or "b")

a) The articles described below this Certificate have been treated with a flame-retardant chemical approved and registered by the State Fire Marshal and that the application of said chemical was done in conformance with the laws of the State of California and the Rules and Regulations of the State Fire Marshal.

Name of chemical used _____ Chem. Reg. No. _____

Method of application _____

(b) The articles described below are made from a flame-resistant fabric or material registered and approved by the State Fire Marshal for such use.

NFPA-701 (large scale)

Trade name of flame-resistant fabric or material used Blockout White 1610

Reg. No. 140.01

The Flame-Retardant Process Used WILL NOT Be Removed By Washing

Fred's Studio Tents & Canopies, Inc.



Plant Supervisor

Product Description 40x100 Series SE Pole Tent Customer Invoice # 17713

Cost Impact

The code change proposal will not increase or decrease the cost of construction .

No additional cost as this is the current practice.

Internal ID: 2005

F244-18

IFC: 3104.3, 3104.4

Proponent: Marcelo Hirschler, GBH International, representing GBH International (gbhint@aol.com)

2018 International Fire Code

Revise as follows:

3104.3 Label. Membrane structures or tents shall have a permanently affixed label bearing the identification of size and fabric or material type. The label shall also indicate that the tent fabric has complied with the requirements of NFPA 701 in accordance with Section 3104.2.

Delete without substitution:

~~**3104.4 Certification.** An affidavit or affirmation shall be submitted to the *fire code official* and a copy retained on the premises on which the tent or air supported structure is located. The affidavit shall attest to all of the following information relative to the flame propagation performance criteria of the fabric:~~

- ~~1. Names and address of the *owners* of the tent or air supported structure.~~
- ~~2. Date the fabric was last treated with flame retardant solution.~~
- ~~3. Trade name or kind of chemical used in treatment.~~
- ~~4. Name of person or firm treating the material.~~
- ~~5. Name of testing agency and test standard by which the fabric was tested.~~

Reason:

The certification information is excessive and unnecessary and increases costs. It does not increase safety. The only key information needed is whether the tent material passes the fire test requirements. A proposed change to the section on fire testing (submitted by ICC FCAC) requires an indication that the tent materials also meet the weathering portion of the fire test.

Cost Impact

The code change proposal will decrease the cost of construction .

This will decrease cost for new tents because they will not need to present unnecessary certificates every time they set up a tent.

Internal ID: 307

F245-18

IFC: 105.6 (New), 202 (New), 3101.1, SECTION 3106 (New), 3106.1 (New), 3106.2 (New), 3106.3 (New), 3106.4 (New), 3106.5 (New), 3106.6 (New), 3106.7 (New), 3106.8 (New), 3106.9 (New), 3106.10 (New), 3106.10.1 (New)

Proponent: Michael O'Brian, Chair, representing FCAC (FCAC@iccsafe.org)

2018 International Fire Code

Add new text as follows:

105.6 Inflatable Amusement Device. Inflatable Amusement Device. The fire code official is authorized to require an operational permit to operate an inflatable amusement device.

Exception: Operation on private property for an event not open to the public.

Add new definition as follows:

INFLATABLE AMUSEMENT DEVICE. A device made of flexible fabric or other combustible materials that is inflated by one or more air-blowers providing internal air pressure to maintain its shape. Such a device is designed for recreational activities that allow occupants to bounce, climb, slide, negotiate an obstacle course or participate in interactive play.

Revise as follows:

3101.1 Scope. Tents, temporary special event structures and *membrane structures* shall comply with this chapter. The provisions of Section 3103 are applicable only to temporary tents and membrane structures. The provisions of Sections 3104 and 3106 are applicable to temporary and permanent tents and membrane structures. The provisions of Section 3105 are applicable to temporary special event structures. The provisions of Section 3106 are applicable to inflatable amusement devices. The provisions of Section 3107 are applicable to outdoor assembly events. Other temporary structures shall comply with the International Building Code.

Add new text as follows:

SECTION 3106 INFLATABLE AMUSEMENT DEVICES

3106.1 Scope. Inflatable amusement devices shall comply with Sections 3106.2 through 3106.10.1.

3106.2 General. Inflatable amusement devices shall be designed, anchored, operated and maintained in accordance with the manufacturer's instructions. A complete copy of the manufacturer's instructions shall be filed with the operational permit and, where required, available at the site of operation for review.

3106.3 Permit required. Where required by the fire code official, the operation of an inflatable amusement device shall require a permit as set forth in Section 105.6

3106.4 Use period. Inflatable amusement devices shall not be operated for a period of more than 14 consecutive days at a single location.

3106.5 Combustible materials. The fabrics, textiles, containment netting and combustible small mesh materials used in the construction of the inflatable amusement device shall meet the flame propagation criteria of Test Method 2 of NFPA 701.

3106.6 Operation. Inflatable amusement devices shall be operated within the environmental conditions specified in the manufacturer's installation and operating instructions for wind and weather. Operators shall be familiar with the weather and wind conditions that exceed manufacturer's operating limits for an inflatable amusement device. Operators shall evacuate and deflate the device and not resume operations until conditions are within the manufacturer's operating limits.

3106.7 Permanent safety label. Every inflatable amusement device shall display one or more permanent labels demonstrating compliance with the requirements in this section.

3106.8 Required operators. The minimum number of approved operators to safely supervise operation of the

device, as required by the manufacturer's instructions for each inflatable amusement device, shall be present at all times when the inflatable amusement device is in use.

3106.9 Electrical equipment and wiring. Electrical equipment, blower motors and temporary wiring for electrical power or lighting shall comply with the applicable provisions of NFPA 70. Extension cords and flexible cords shall be listed and labeled in accordance with UL 817. Electrical equipment, blower-motors and wiring utilized outdoors shall be listed and labeled for outdoor use.

3106.10 Portable generators. Portable generators shall comply with the applicable provisions of NFPA 70 and with the portable generator requirements of this code.

3106.10.1 Portable fire extinguishers. Each generator shall be provided with an approved portable fire extinguisher complying with Section 906 and placed in an approved location.

Reason:

This proposal has been prepared through discussions with code officials, industry representatives and other stakeholders. Past events were analyzed related to outdoor “bounce houses” that were uplifted by wind gusts while occupied thereby resulting in injury to children and/or adults that were trapped inside. These new code requirements are simple and intended to improve the authority of code officials to ensure public safety when inflatable amusement devices are used for public gatherings or events.

This proposal introduces basic safety requirements for inflatable amusement devices also known as “bounce houses”. There have been numerous reported incidents of accidents and injuries involving these devices caused by weather events such as sustained or wind gusts and/or improper set-up, anchorage or use where the “bounce house” is uplifted, carried away and/or overturned with children or adults inside.

Chapter Scoping section modified to reference proposed new section.

This new section adds an “optional” operational permit requirement intended to cover public events and excludes operation on private (residential) property.

This section adds basic fire and electrical safety requirements for the construction, placement and operation of portable inflatable amusement devices. The section addresses safety requirements for both outdoor and indoor use of these devices.

A definition for inflatable amusement devices is also included to correlate the type of devices covered by these new IFC code requirements.

This proposal is submitted by the ICC Fire Code Action Committee (FCAC). The FCAC was established by the ICC Board of Directors to pursue opportunities to improve and enhance assigned International Codes with regard to fire safety and hazardous materials in new and existing buildings and facilities and the protection of life and property in wildland urban interface areas. In 2017 the Fire-CAC has held 3 open meetings. In addition, there were numerous conference calls, Regional Work Group and Task Group meetings for the current code development cycle, which included members of the committees as well as any interested parties, to discuss and debate the proposed changes. Related documentation and reports are posted on the FCAC website at: <https://www.iccsafe.org/codes-tech-support/cs/fire-code-action-committee-fcac/>

Cost Impact

The code change proposal will not increase or decrease the cost of construction .

This proposal adds requirements for inflatable amusement devices. This use of these devices and the requirements proposed have no relation to building construction or building construction costs.

Internal ID: 260

F246-18

IFC: 3106.4.1, 3106.4.1.1 (New), 3106.4.1.2 (New)

Proponent: Richard Nix, representing Entertainment Services & Technology Association/Event Safety Alliance (rnix@zoomtown.com)

2018 International Fire Code

3106.4.1 Public safety plan for gatherings. A public safety plan shall be prepared where required by Section 403.12.2. The public safety plan shall be submitted to the *fire code official* with the application for an operational permit as required by Section 3106.2.2.

Add new text as follows:

3106.4.1.1 Event designated responsible person. Outdoor assembly events shall have a designated person responsible for the temporary outdoor assembly event structures on the site. The designated person shall have sufficient knowledge of the construction documents, manufacturer's recommendations and operations plan to make judgments regarding the event's safety and to coordinate with the fire code official when necessary.

3106.4.1.2 Operations plan. An event operations plan shall be required for outdoor assembly events. It shall contain the event's operational guidelines, procedures for environmental monitoring and actions to be taken under specified conditions consistent with the permit and the construction documents. It shall include the public safety plan if required by Section 403.12.2.

Reason:

This proposed change both supports and enhances the current public safety plan requirements of Chapter 4, with specific consideration given to outdoor assembly events. This proposed change also responds to industry and code administration discussions about incorporating more of ANSI E1.21's Operations Management Plan ("OMP") concepts into Chapter 31, for a broader scope of coverage relative to outdoor assembly events, and relative to structures not specifically covered in the scope of ANSI E1.21, but which are explicitly covered under the scope of Chapter 31. These concepts are considered beneficial and directly attributable to enhancing event safety.

The basic premise of ANSI E1.21's OMP requirements is to establish a general plan and hierarchy responsibilities to facilitate execution of the plan's requirements, particularly with regard to aspects of safety. For example, to enhance structural safety, the OMP contains the structural capacity for the event structure(s), which are in turn used to establish operational controls and thresholds, such as triggering thresholds for event evacuation, and structural safety zone perimeters. These are in turn used in conjunction with any mitigating actions that must be taken when triggered, such as event evacuation due to inclement weather or high winds. The OMP also requires a designated responsible person, thus reinforcing the current code requirements in Section 403, wherein the code official must determine if a weather monitoring person is a necessary consideration for the public safety plan. For structures within the scope of E1.21, this is not an optional suggestion - it is a requirement, and yet those structures represent no more or less significant risk than other temporary structures used for special events purposes.

The change regarding operations plans satisfies any question about what information is required. The change regarding a designated person in responsible charge enhances the current public safety plan consideration for a weather monitoring person. In fact and practice these roles and responsibilities can be met by the same person.

Additional discussion:

Several recent and historical incidents occurring during special events have resulting in injury or death, as a result of structural collapse due to high winds. These tragedies can also be directly attributed to the absence of an operations management plan, or the failure to implement the steps required by such a plan if it did exist. Bringing these topics into the code adds irrefutably clear and significant enhancement to outdoor assembly event safety, first by validating the importance of having the safety plan and personnel requirements for outdoor assembly events documented, and second by increasing awareness for event safety at the event planning and initial permitting approval stages.

In 2011 the stage roof system at the Indianapolis State Fair collapsed due to high winds, killing 12 people and injuring many others. In many ways that tragedy influenced significant changes in the 2015 code.

In 2015, three tent collapses causing deaths and injuries (NH, Wood Dale, St Louis) occurred as a result of high winds. In at least two of those cases, injury and death could have been prevented had evacuation occurred in a timely manner, directing people to an appropriate safe haven. These tragedies have also contributed to increased concern and awareness such that the changes made by the 2015 code were again enhanced, and a new section for outdoor assembly events was added to the 2018 code. The topic of event safety - how to improve it, how to manage it, and how to enforce it - is ever-present in code administration, in standards development activities and in the special

events industry at large.

Cost Impact

The code change proposal will not increase or decrease the cost of construction .

This proposed change has no impact to cost of construction, because its requirements for documentation of essential information are already directly related to the code official's assessment of the public safety plan's essential requirements. The event production industry already implements these concepts, in principle through documents such as the Event Safety Guide and ANSI E1.21-2013, and in practice through voluntary compliance with those approved consensus standards and industry guidelines documents.

Internal ID: 1164

F247-18

IFC: 3106.4.2, 3106.4.2.1 (New)

Proponent: Richard Nix, representing Entertainment Services & Technology Association/Event Safety Alliance
(rnix@zoomtown.com)

2018 International Fire Code

3106.4.2 Weather monitoring person. Where required by the *fire code official*, the event operator or agent shall designate one qualified individual to continuously monitor local weather reports, forecasts and conditions. Said person shall be responsible for initiating weather-related event mitigation activities, ordering the suspension or cancellation of the outdoor assembly event and issuing the evacuation signal in accordance with the *approved* public safety plan.

Add new text as follows:

3106.4.2.1 Mandatory weather evacuation. Temporary outdoor assembly events shall be evacuated when wind speeds reach the threshold stated in the public safety plan. Where structures are erected on the event site, mandatory evacuation of the structures' safety zone perimeter shall occur when wind speeds exceed 35 miles per hour (3-second gust), unless other limiting safety criteria designates to the contrary. The public safety plan shall include all other conditions in which evacuations are necessary, including any mitigating actions required to occur prior to evacuation.

Reason:

Deadly incidents continue to occur as a direct result of failure to evacuate during severe weather. For outdoor temporary structures, the single most common cause of structural collapse is high winds creating forces in excess of the structure's capacity, and usually resulting in a failure of the structure's lateral (main wind) force resisting system.

This proposed change introduces a mandatory evacuation threshold in order to enhance safety for the event, prevent injury or death which may result from structural collapse during high-wind events by ensuring there is an approved plan to evacuate prior to wind speeds becoming dangerous. An ancillary yet critically important by-product of this proposal is that the structures' wind capacity thresholds must be determined in order to establish the operation limits under which the structure may be used.

Justification for why the 35 mph threshold has been determined is as follows:

- The National Weather Service defines "Severe Thunderstorm" as, ...A thunderstorm that produces a tornado, **winds of at least 58 mph** (50 knots or ~93 km/h), and/or **hail at least 1" in diameter**. Structural wind damage may imply the occurrence of a severe thunderstorm. A thunderstorm wind equal to or greater than 40 mph (35 knots or ~64 km/h) and/or hail of at least ½" is defined as approaching severe.
- Just after Hurricane Harvey, the Weather Channel advises the public that ...the winds have died down to about 35 MPH, but stay out of the wind because 35 MPH is still considered dangerous.
- Just prior to Hurricane Irma, Government agencies and first responders advise that, once wind speeds reach 45 MPH, they will cease response activities.
- According to the production personnel who participated in the drafting of the original ANSI E1.21 document, 40 MPH is considered the threshold at which working in wind surpasses uncomfortable, and becomes potentially dangerous. This threshold is still considered appropriate today.
- 29 CFR 1926.968 Subpart V provides this note to the definition of "high wind": The Occupational Safety and Health Administration normally considers winds exceeding 64.4 kilometers per hour (40 miles per hour), or 48.3 kilometers per hour (30 miles per hour) if the work involves material handling, as meeting this criteria, unless the employer takes precautions to protect employees from the hazardous effects of the wind.
- ALL weather-related information services address weather-related risks in context of outdoor assembly events.
- <https://weather.com/storms/severe/news/outdoor-festivals-severe-weather-plan>

In summary:

- 58 MPH – wind speed at which the NWS classifies a "Severe Thunderstorm"
- 45 MPH – wind speed at which first responders cease to respond to emergencies.
- 40 MPH – wind speed at which the NWS classifies as "approaching severe"
- 40 MPH – wind speed at which OSHA classifies as "High Wind"
- 40 MPH – the sustained wind speed at which the NWS issues a "High Wind Warning"

34-40 MPH - Beaufort Wind Scale Force 8 = Gale force winds, twigs breaking off trees, generally impedes progress

30 MPH - wind speed at which OSHA classifies as "high wind" for material handling

Therefore, 35 MPH is a reasonable high-wind threshold for mandatory evacuation, but this proposal also allows consideration of other criteria.

Cost Impact

The code change proposal will not increase or decrease the cost of construction .

Regardless if an evacuation is necessary or not, this proposed change has no impact to the cost of construction because any necessary preparations to effect the action - the public safety plan itself, the necessity for a weather monitoring person, the need for trained crowd managers - are already required by Chapter 4.

Internal ID: 1174

F248-18

IFC: 3106.4.3

Proponent: Richard Nix, representing Entertainment Services & Technology Association/Event Safety Alliance (rnix@zoomtown.com)

2018 International Fire Code

Revise as follows:

3106.4.3 Crowd managers. Where events involve a gathering of more than ~~1,000~~500 people, trained crowd managers shall be provided in accordance with Section 403.12.3.

Reason:

The basic threshold of 500 persons, triggering the requirement for trained crowd managers, is established by 403.12.3, and the minimum number of crowd managers required per number of occupants is established by the charging statement of 403.12.3.1. However, 403.12.3.1 exception 1 permits the triggering threshold to be raised for outdoor assembly events. When a weather monitoring person is required by the code official, this exception potentially places a tremendous burden on that designated weather monitoring person, when - without the exception - 2 to 3 crowd managers would otherwise be required and be available to support the potentially critical life safety responsibilities of the designated weather monitoring person. This proposed change supports the primary triggering threshold of 500 persons set by 403.12.3, and supports the minimum number of trained crowd managers required by 403.12.3.1.

In accordance with the public safety plan requirements of 403.12.2, if the FCO determines a designated weather monitoring person is necessary, then that person has one of the most important tasks potentially occurring at an outdoor assembly event: evacuation in accordance with the public safety plan.

Recent event tragedies in the US and around the world (Wood Dale Festival tent collapse; New Hampshire circus tent collapse; Brazil EDM festival, and others) have demonstrated the importance of weather monitoring in conjunction with the support staff to facilitate and execute an evacuation plan when necessary.

Cost Impact

The code change proposal will not increase or decrease the cost of construction .

This proposed change has no impact on cost of construction. This proposed change has minimal cost impact to operational staffing requirements compared to overall event production costs.

Internal ID: 1163

F249-18

IFC: 3107.15.1

Proponent: Kevin Scott, representing KH Scott & Associates LLC (khscottassoc@gmail.com)

2018 International Fire Code

Revise as follows:

3107.15.1 Batteries. Batteries shall be disconnected ~~in an appropriate manner.~~ except where the fire code official requires that the batteries remain connected to maintain safety features.

Reason:

This section is revised to correlate with changes to the 2018 IFC which allow batteries to remain connected in some situations.

Many alternative-fuel vehicles have safety features built-in to the vehicle that monitor hazards. When the battery is disconnected, those safety features are lost.

This revision correlates with Section 314.4, Item 1 and provides an increased level of safety for alternative-fuel vehicles.

Cost Impact

The code change proposal will not increase or decrease the cost of construction .

This proposal does not affect construction.

Internal ID: 2099

F250-18

IFC: 3203.1

Proponent: Bob Morgan, Fort Worth Fire Department, representing Fort Worth Fire Department

2018 International Fire Code

Revise as follows:

3203.1 Classification of commodities. Commodities shall be classified as Class I, II, III, IV or high hazard in accordance with Sections 3203.2 through 3203.10.3. Materials listed within each commodity classification are assumed to be unmodified for improved combustibility characteristics. Use of flame-retarding modifiers or the physical form of the material could change the classification.

Where a specific commodity cannot be identified, such as a speculative warehouse building, the required fire protection system and life safety features shall be installed assuming Class IV commodities as a minimum criteria, to the maximum pile height, based on available clear height in the building.

Reason:

The intent is to address the multitude of speculative warehouse buildings constructed without due regard to the future tenants. This provision simply provides guidance as to how to design per Chapter 32 based on a conservative assumption, so as to accommodate the majority of future tenants without significantly changing the fire protection features in the building retroactively.

Cost Impact

The code change proposal will increase the cost of construction .

The potential is there to increase the cost of construction if the speculative warehouse is designed based on an assumption of commodity classification that is less than Class IV. It is likely that many would argue that Group A plastics is a more appropriate classification for speculative buildings simply based on the majority of warehousing operations.

Internal ID: 921

F251-18

IFC: TABLE 3203.8

Proponent: Michael O'Brian, representing FCAC (fcac@iccsafe.org); Robert Davidson, Davidson Code Concepts, LLC, representing Tesla, USA (rjd@davidsoncodeconcepts.com)

2018 International Fire Code

Revise as follows:

**TABLE 3203.8
EXAMPLES OF COMMODITY CLASSIFICATION**

PRODUCT CATEGORY	PRODUCT	CLASSIFICATION
Aerosols	Level 1	Class III (See Chapter 51)
	Level 2	Class IV (See Chapter 51)
	Level 3	High-hazard (See Chapter 51)
Batteries	Dry cells (excludes lithium, lithium-ion and other similar exotic metals or combustible electrolyte); without blister packing (if blister packed, refer to the commodity classification definitions)	Class I
	Dry cells (nonlithium or similar exotic metals); in blister packing; cartoned	Class II
	Vehicle; any size (for example, automobile or truck); empty plastic casing	High-hazard (Group A unexpanded)
	Vehicle; large (in other words, truck or larger); dry or wet cells (excludes lithium-ion and other cells containing combustible electrolytes)	High-hazard (Group A unexpanded)
	Vehicle; small (for example, automobile); wet cells (excludes lithium-ion and other cells containing combustible electrolytes)	Class I
	<u>Lithium-ion</u>	<u>High-hazard</u>
Biomass	Circular baled corn stover	Class IV
	Rectangular baled corn stover	Class III
	Rectangular baled switchgrass	High-hazard
Empty containers	Noncombustible	Class I
	PET	Class IV
	Rigid plastic (not including PET)	High-hazard (Group A unexpanded)
	Wood; solid sided (such as crates, boxes)	Class II
Film rolls, including photographic	Polypropylene, polyester, polyethylene; rolled on any reel type	High-hazard (Group A unexpanded)
	35 mm metal film cartridges in polyethylene cans; cartoned	Class III
	Motion picture or bulk rolls in polycarbonate, polyethylene or in metal cans; polyethylene bagged; cartoned	Class II
	Rolls in polycarbonate plastic cassettes; cartoned	Class IV
	Photographic paper; sheets; bagged in polyethylene; cartoned	Class III
Flammable and combustible liquids	Glycol in combustible containers (50 percent or greater)	High-hazard
	Lacquers, which dry by solvent evaporation, in metal cans or cartons	High-hazard
	Lighters; butane; blister-packed; cartoned	High-hazard (Group A unexpanded)
	Over 20- and up to 50-percent alcohol (such as alcoholic beverages, hair spray); up to 1-gallon glass bottles or jars; in racks; cartoned	Class III
	Over 20- and up to 50-percent alcohol (such as alcoholic beverages, hair spray); up to 1-gallon glass bottles or jars; palletized; cartoned	Class IV
	Over 20- and up to 50-percent alcohol (such as alcoholic beverages, hair spray); up to 1-gallon plastic bottles or jars; cartoned	Class IV
	Up to 20-percent alcohol (such as alcoholic beverages, flavoring extracts); greater than 5-gallon plastic containers with wall thickness greater than 0.25 inch	High-hazard (Group A unexpanded)

	Up to 20-percent alcohol (such as alcoholic beverages, flavoring extracts); metal, glass or ceramic containers	Class I
	Up to 20-percent alcohol (such as alcoholic beverages, flavoring extracts); plastic containers greater than 5 gallons and wall thickness up to 1/4 inch	Class II
	Up to 20-percent alcohol (such as alcoholic beverages, flavoring extracts); up to 5-gallon plastic bottles or jars	Class I
	Up to 20-percent alcohol (such as alcoholic beverages, flavoring extracts); wood containers	Class II
	Lubricating or hydraulic fluid in plastic containers	High-hazard
	Nail polish; up to 2-ounce glass bottles or jars; cartoned	Class IV
	Nail polish; up to 2-ounce plastic bottles or jars; cartoned	High-hazard (Group A unexpanded)
Flammable solids	Except solid combustible metals	High-hazard
Food products, frozen	In nonwaxed or nonplastic packaging	Class I
	In plastic trays	Class III
	In waxed or plastic-coated paper packaging	Class II
Food products, nonfrozen	Butter (stick or whipped spread) or margarine (up to 50-percent oil)	Class III
	Butter; whipped spread	Class III
	Dry foods (such as baked goods, candy, cereals, cheese, chocolate, cocoa, coffee, grains, granular sugar, nuts); bagged or cartoned	Class III
	Foods (such as coffee, fish products, fruit, meat products, nuts, poultry); metal cans	Class I
	Fruits and vegetables (noncombustible semiliquid); crushed; plastic containers up to 5 gallons	Class I
	Fruits and vegetables; fresh; wood spacers, nonplastic trays or containers	Class I
	Margarine; over 50- and up to 80-percent oil	High-hazard (Group A unexpanded)
	Meat; fresh; no plastic packaging; uncartoned	Class I
	Meat; fresh; no plastic packaging; cartoned	Class II
	Meat; fresh; plastic tray	Class III
	Milk; any container; stored in solid plastic crates	High-hazard (Group A unexpanded)
	Milk; paper containers, or plastic bottles or jars up to 5 gallons	Class I
	Salt; bagged	Class I
	Salt; cartoned	Class II
	Snack foods (such as potato chips); plasticized aluminum bags; cartoned	High-hazard (Group A unexpanded)
Syrup; wooden container	Class II	
Furniture and bedding	Box spring; standard (minimal plastic materials)	Class III
	Box spring; wrapped in plastic cover	Class IV
	Furniture and bedding; with foam cushioning	High-hazard (Group A expanded)
	Furniture; metal (such as file cabinets or desks with minimal plastic trim); cartoned	Class I
	Furniture; wood (such as doors, windows, cabinets); no plastic coverings or foam cushioning	Class III
	Furniture; wood; plastic coverings; nonexpanded plastic trim	Class IV
	Mattress; foam (in finished form)	High-hazard (Group A expanded)

	Pillows, foam rubber and foam plastics	High-hazard (Group A expanded)
Housing materials and appliances	Appliances; major (for example, stoves, refrigerators); no appreciable plastic interior or exterior trim; cartoned	Class II
	Appliances; major (for example, stoves, refrigerators); no appreciable plastic interior or exterior trim; uncartoned	Class I
	Appliances; no appreciable plastic exterior trim (interior of unit can have appreciable plastic)	Class III
	Carpet tiles; cartoned	High-hazard (Group A unexpanded)
	Fiberglass insulation; paper-backed rolls; bagged or unbagged	Class IV
	Floor coverings; vinyl, stacked tiles	Class IV
	Floor coverings; vinyl; rolled	High-hazard (Group A unexpanded)
	Gypsum board	Class I
	Housing materials (such as sinks, countertops); noncombustible, cartoned or crated	Class II
	Light fixtures; nonplastic; cartoned	Class II
	Paint; oil-based; friction-top metal containers; cartoned	Class IV
	Paint; water-based (latex); friction-top metal containers; cartoned	Class I
	Paper; asphalt; rolled, horizontal or vertical storage	High-hazard
	Roofing shingles; asphalt-coated fiberglass	Class III
	Roofing shingles; asphalt-impregnated felt	Class IV
	Miscellaneous	Ammunition; small arms and shotgun; cartoned
Charcoal; mineral-spirit impregnated; bagged		High-hazard (Group A expanded)
Charcoal; standard (nonmineral-spirit impregnated); bagged		Class III
Fertilizers; nitrates; bagged		Class II
Fertilizers; phosphates; bagged		Class I
Leather hides; baled		Class II
Leather; finished products (such as shoes, jackets, gloves, bags, luggage, belts)		Class III
Motors; electric		Class I
Pallets and flats that are idle; combustible		High-hazard
Shock absorbers; metal dust cover		Class II
Shock absorbers; plastic dust cover		Class III
Skis; wood		Class III
Skis; composite materials (such as plastic, fiberglass, foam)		Class IV
Tobacco products; cartoned		Class III
Toys; stuffed; foam or synthetic		High-hazard (Group A expanded)
Transformer; dry or empty (in other words, void of oil)		Class I
Noncombustible liquids	Liquids or semiliquids; PET containers greater than 5 gallons having a nominal wall thickness greater than 1/4 inch	Class IV
	Liquids or semiliquids; PET containers up to 5 gallons having a nominal wall thickness less than 1/4 inch	Class I
	Liquids or semiliquids (such as crushed fruits and vegetables); plastic containers up to 5-gallon capacity	Class I

	Liquids or semiliquids; plastic (except PET) containers greater than 5-gallon capacity having a nominal wall thickness greater than 1/4 inch	High-hazard (Group A unexpanded)
	Liquids or semiliquids; plastic (except PET) containers greater than 5-gallon capacity having a nominal wall thickness up to 1/4 inch	Class II
	Liquids; cardboard drink boxes, plastic coated, wax coated, and/or aluminum lined; uncartoned or on corrugated carton trays with plastic sheeting	Class I
	Liquids; cardboard drink boxes, plastic coated, wax coated, and/or aluminum lined; stored in plastic containers	High-hazard (Group A unexpanded)
	Liquids; glass bottles or jars; cartoned	Class I
	Liquids; less than 5-gallon plastic containers	Class I
	Liquids; pharmaceuticals (nonflammable); glass bottles or jars; cartoned	Class II
	Liquids; plastic bottles or jars; stored in open or solid plastic crates	High-hazard (Group A unexpanded)
Paper products	Book signatures (paper part of book without hard cover)	Class II
	Cartons (such as cardboard flats); corrugated; partially assembled	Class IV
	Cartons (such as cardboard flats); corrugated; unassembled in neat piles	Class III
	Cartons; wax coated, single-walled corrugated	High-hazard (Group A unexpanded)
	Cellulosic paper products; nonwax coated (such as books, cardboard games, cartoned tissue products, magazines, newspapers, paper cups, paper plates, paper towels, plastic-coated paper food containers, stationary)	Class III
	Cellulosic paper products; wax coated (such as paper plates, cups); loosely packed; cartoned	High-hazard (Group A unexpanded)
	Cellulosic paper products; wax coated (such as paper plates, cups); nested; cartoned	Class IV
	Matches; paper-type; cartoned	Class IV
	Matches; wooden; cartoned	High-hazard (Group A unexpanded)
	Rolled; lightweight; in storage racks	Class IV
	Rolled; medium or heavyweight; in storage racks or onsite	Class III
	Rolled; in horizontal storage or vertical storage that is banded or protected with an approved wrap	Class III
	Rolled; in vertical storage that is unbanded or not protected with an approved wrap	High-hazard
	Tissue products; plastic wrapped; cartoned	Class III
	Tissue products; plastic wrapped; uncartoned	High-hazard (Group A unexpanded)
Plastic, rubber	ABS (Acrylonitrile-butadiene-styrene copolymer)	High-hazard (Group A unexpanded)
	Acetal (polyformaldehyde)	High-hazard (Group A unexpanded)
	Acrylic (polymethyl methacrylate)	High-hazard (Group A unexpanded)
	Automobile bumpers and dashboards	High-hazard (Group A expanded)
	Butyl rubber	High-hazard (Group A unexpanded)
	Cellulose acetate	Class IV (Group B plastic)

Cellulose acetate butyrate	High-hazard (Group A unexpanded)
Chloroprene rubber	Class IV (Group B plastic)
Containers; Nonexpanded plastic gridded or solid; collapsed or nested with no air spaces	High-hazard (Group A unexpanded)
ECTFE (ethylene-chlorotrifluoro-ethylene copolymer)	Class IV (Group B plastic)
EPDM (ethylene-propylene rubber)	High-hazard (Group A unexpanded)
ETFE (ethylene-tetrafluoroethylene copolymer)	Class IV (Group B plastic)
Ethyl cellulose	High-hazard (Group A unexpanded)
FEP (fluorinated ethylene-propylene copolymer)	Class IV (Group B plastic)
FRP (fiberglass-reinforced polyester)	High-hazard (Group A unexpanded)
Melamine (melamine formaldehyde)	Class III (Group C plastic)
Nitrile rubber (acrylonitrile-butadiene rubber)	High-hazard (Group A unexpanded)
Nylon (nylon 6, nylon 6/6)	High-hazard (Group A unexpanded)
PCTFE (polychlorotrifluoroethylene)	Class III (Group C plastic)
PET (Polyethylene terephthalate-thermoplastic polyester)	High-hazard (Group A unexpanded)
Phenolic	Class III (Group C plastic)
Plastics; stored in fully closed and solid (no openings) metal containers	Class I
Polybutadiene	High-hazard (Group A unexpanded)
Polycarbonate	High-hazard (Group A unexpanded)
Polyester elastomer	High-hazard (Group A unexpanded)
Polyethylene	High-hazard (Group A unexpanded)
Polypropylene	High-hazard (Group A unexpanded)
Polystyrene; foam products (such as plates, cups)	High-hazard (Group A expanded)
Polystyrene; rigid products	High-hazard (Group A unexpanded)
Polyurethane	High-hazard (Group A expanded)
PTFE (polytetrafluoroethylene)	Class III (Group C plastic)
PVC (polyvinyl chloride) products; plasticizer content 20 percent or less	Class III (Group C plastic)
PVC (polyvinyl chloride) products; plasticizer content greater than 20 percent	High-hazard (Group A unexpanded)
PVC resins; bagged	Class III (Group C plastic)
PVDC (polyvinylidene chloride)	Class III (Group C plastic)
PVDF (polyvinylidene fluoride)	Class III (Group C plastic)
PVF (polyvinyl fluoride)	High-hazard (Group A unexpanded)
Pyroxylin	High-hazard
Rubber; natural in blocks; cartoned	High-hazard (Group A unexpanded)
Rubber; natural; expanded	High-hazard (Group A expanded)
Rubber; natural; Nonexpanded	High-hazard (Group A unexpanded)

	Rubber; synthetic (santoprene)	High-hazard (Group A unexpanded)
	Rubber tires	High-hazard
	SAN (styrene acrylonitrile)	High-hazard (Group A unexpanded)
	SBR (styrene-butadiene rubber)	High-hazard (Group A unexpanded)
	Silicone rubber	Class IV (Group B plastic)
	Urea (urea formaldehyde)	Class III (Group C plastic)
Plastic containers	Bottles or jars greater than 1 gallon containing noncombustible solids	High-hazard (Group A unexpanded)
	Bottles or jars up to 1 gallon containing noncombustible solids	High-hazard (Group A unexpanded)
Powders, pills	Pharmaceutical pills; glass bottles or jars; cartoned	Class II
	Pharmaceuticals pills; plastic bottles or jars; cartoned	Class IV
	Polyvinyl alcohol (PVA) resins; bagged	Class IV
	Powders; combustible (ordinary—such as sugar or flour); free-flowing; bagged	Class II
	Powders; noncombustible free-flowing powdered or granular materials (such as cement, calcium chloride, clay, iron oxide, sodium chloride, sodium silicate); bagged	Class I
	Powders; noncombustible; glass bottles or jars; cartoned	Class I
	Powders; noncombustible; PET bottles or jars	Class II
	Powders; noncombustible; plastic (other than PET) bottles or jars; uncartoned	High-hazard (Group A unexpanded)
	Powders; noncombustible; plastic bottles or jars greater than 1-gallon capacity	High-hazard (Group A unexpanded)
	Powders; noncombustible; plastic bottles or jars up to 1-gallon capacity; cartoned	Class IV
Textile materials and products	Cloth; natural fibers; baled	Class III
	Cloth; synthetic cloth	Class IV
	Clothing; natural fibers (such as wool, cotton) and viscose	Class III
	Cotton; cartoned	Class III
	Diapers; cotton or linen	Class III
	Diapers; plastic or nonwoven fabric; cartoned	Class IV
	Diapers; plastic or nonwoven fabric; plastic-wrapped; uncartoned	High-hazard (Group A unexpanded)
	Fabric; rayon and nylon	Class IV
	Fabric; synthetic (except rayon and nylon); greater than 50/50 blend	High-hazard (Group A unexpanded)
	Fabric; synthetic (except rayon and nylon); up to 50/50 blend	Class III
	Fabric; vinyl-coated (such as tablecloth); cartoned	High-hazard (Group A unexpanded)
	Fibers; rayon and nylon; baled	Class IV
	Fibers; synthetic (except rayon and nylon); baled	High-hazard (Group A unexpanded)
	Thread or yarn; rayon and nylon; wood or paper spools	Class IV
	Thread or yarn; rayon or nylon; plastic spools	High-hazard (Group A unexpanded)
Thread or yarn; synthetic (except rayon and nylon); greater than 50/50 blend; paper or wood spools	Class IV	

	Thread or yarn; synthetic (except rayon and nylon); greater than 50/50 blend; plastic spools	High-hazard (Group A unexpanded)
	Thread or yarn; synthetic (except rayon and nylon); up to 50/50 blend; plastic spools	High-hazard (Group A unexpanded)
	Thread or yarn; synthetic (except rayon and nylon); up to 50/50 blend; wood or paper spools	Class III
Wax products	Candles	High-hazard (Group A expanded)
	Paraffin or petroleum wax; blocks	High-hazard (Group A expanded)
Wire, cable, spools	Spools; plastic; empty	High-hazard (Group A unexpanded)
	Spools; wood; empty	Class III
	Wire or cable; PVC insulated; metal or wood spools	Class II
	Wire or cable; PVC insulated; plastic spools	Class IV
	Wire; bare; metal spools; uncartoned	Class I
	Wire; bare; metal spools; cartoned	Class II
	Wire; bare; plastic spools; cartoned	Class IV
	Wire; bare; plastic spools; uncartoned	High-hazard (Group A unexpanded)
	Wire; bare; wood or cardboard spools	Class II
Wood products	Wood patterns	Class IV
	Wood products (such as fiberboard, lumber, particle board, plywood, pressboard with smooth ends and edges); bundled solid blocks	Class II
	Wood products (such as fiberboard, lumber, particle board, plywood, pressboard with smooth ends and edges); unbundled or nonsolid blocks	Class III
	Wood products (such as toothpicks, clothespins and hangers)	Class III

For SI: 1 inch = 25.4 mm, 1 gallon = 3.8 L, 1 ounce = 29.57 ml.

Reason:

This proposal adds lithium-ion batteries to Table 3203.8 of the IFC. Lithium-ion batteries will burn vigorously and initial laboratory testing has indicated they will present a challenging fire in storage arrangements. Presently the code lacks guidance on the protection levels necessary for the storage of this product. By classifying lithium-ion batteries as a high-hazard commodity, the user now has a clear commodity to apply to Table 3206.2 for general fire protection and life safety systems when lithium-ion batteries are stored.

This proposal is submitted by the ICC Fire Code Action Committee (FCAC). The FCAC was established by the ICC Board of Directors to pursue opportunities to improve and enhance assigned International Codes with regard to fire safety and hazardous materials in new and existing buildings and facilities and the protection of life and property in wildland urban interface areas. In 2017 the Fire-CAC has held 3 open meetings. In addition, there were numerous conference calls, Regional Work Group and Task Group meetings for the current code development cycle, which included members of the committees as well as any interested parties, to discuss and debate the proposed changes. Related documentation and reports are posted on the FCAC website at: <https://www.iccsafe.org/codes-tech-support/cs/fire-code-action-committee-fcac/>

Cost Impact

The code change proposal will decrease the cost of construction .

With the commodity in the IFC, the designer no longer needs to provide the code official documentation to classify the commodity.

Internal ID: 753

F252-18

IFC: FIGURE 3203.9(1), FIGURE 3203.9(2)

Proponent: Michael O'Brian, Chair, representing FCAC (fcac@iccsafe.org)

2018 International Fire Code

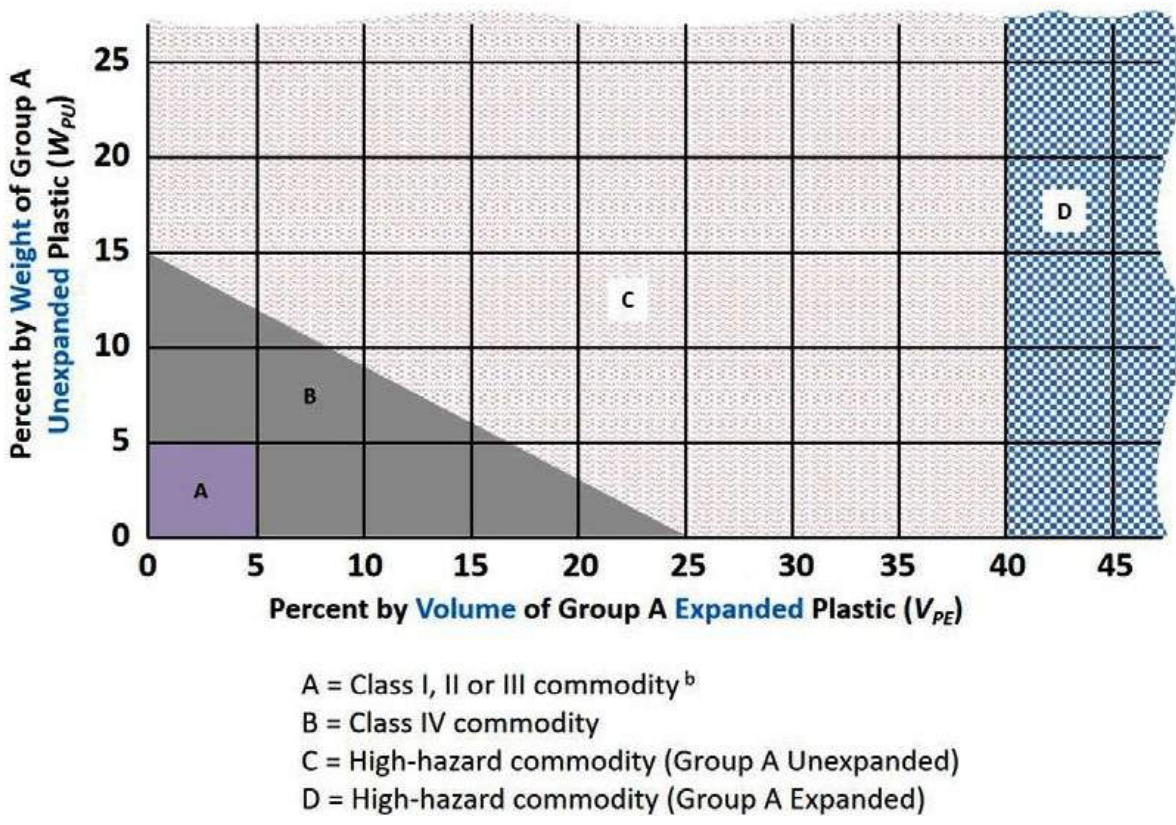
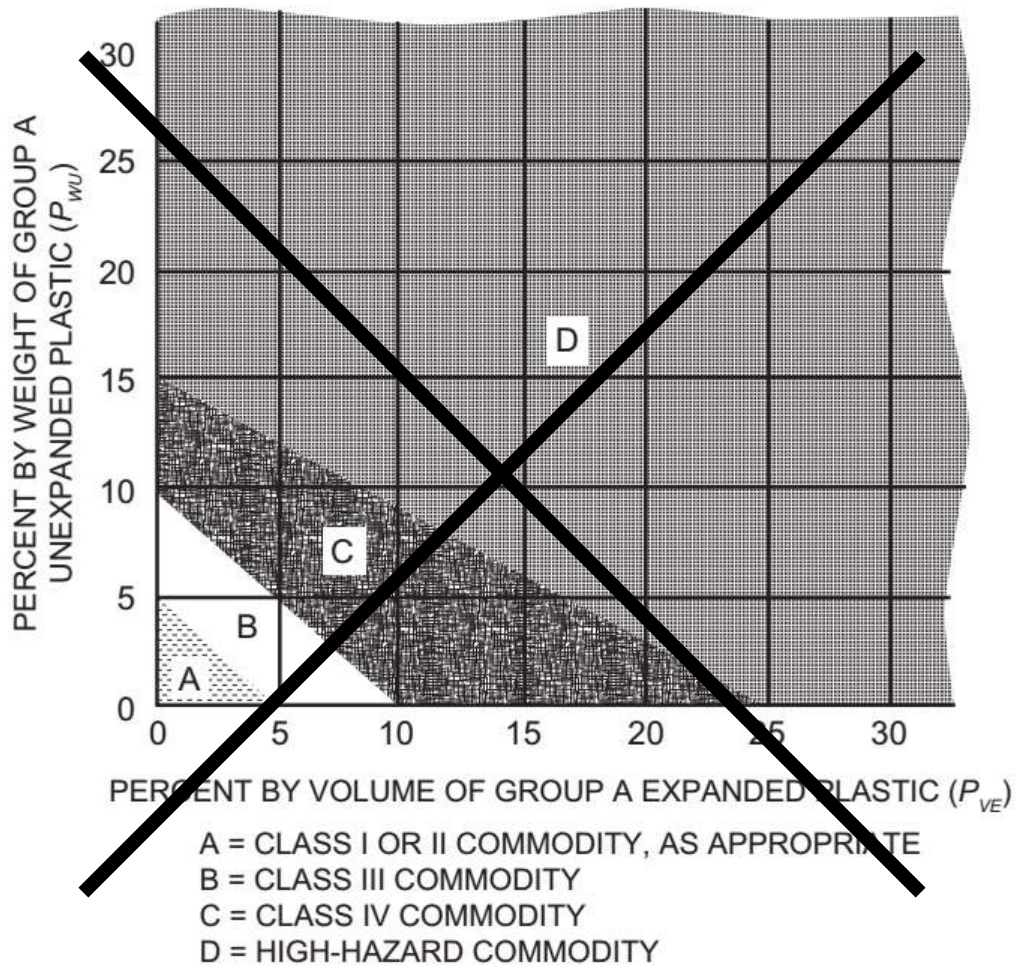
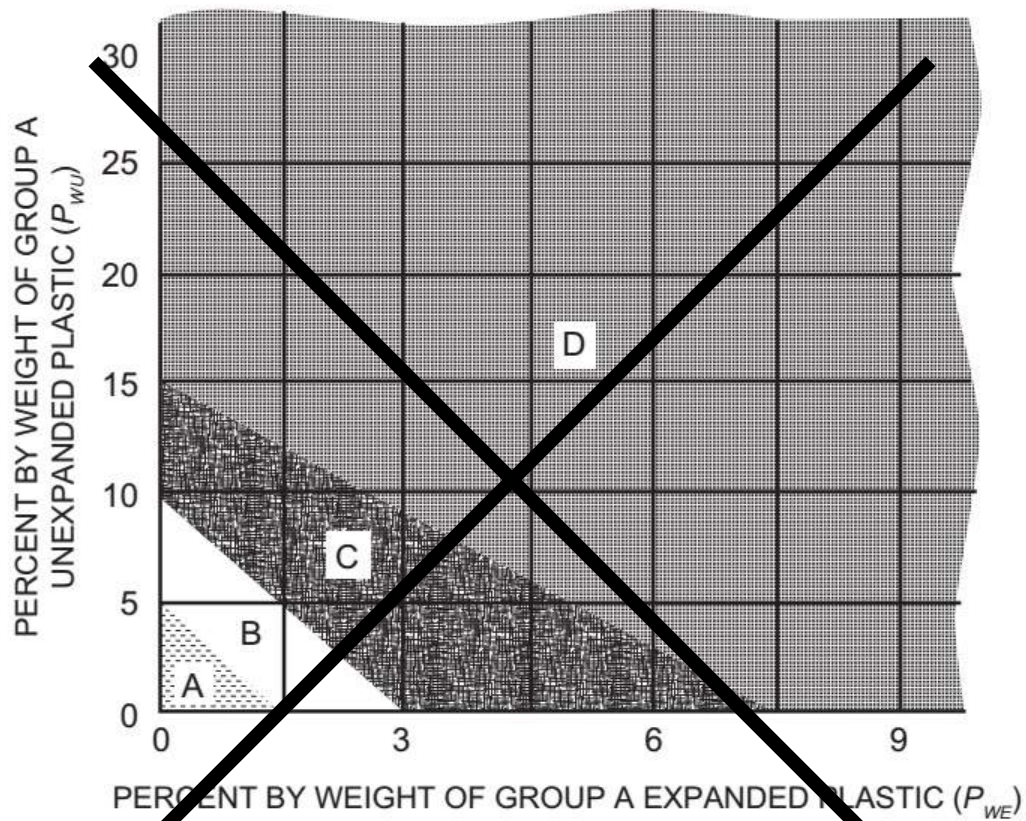

FIGURE 3203.9(1)
EVALUATION BY VOLUME OF GROUP A EXPANDED PLASTICS IN MIXED COMMODITIES^{a, b}



- A = CLASS I OR II COMMODITY, AS APPROPRIATE
- B = CLASS III COMMODITY
- C = CLASS IV COMMODITY
- D = HIGH-HAZARD COMMODITY

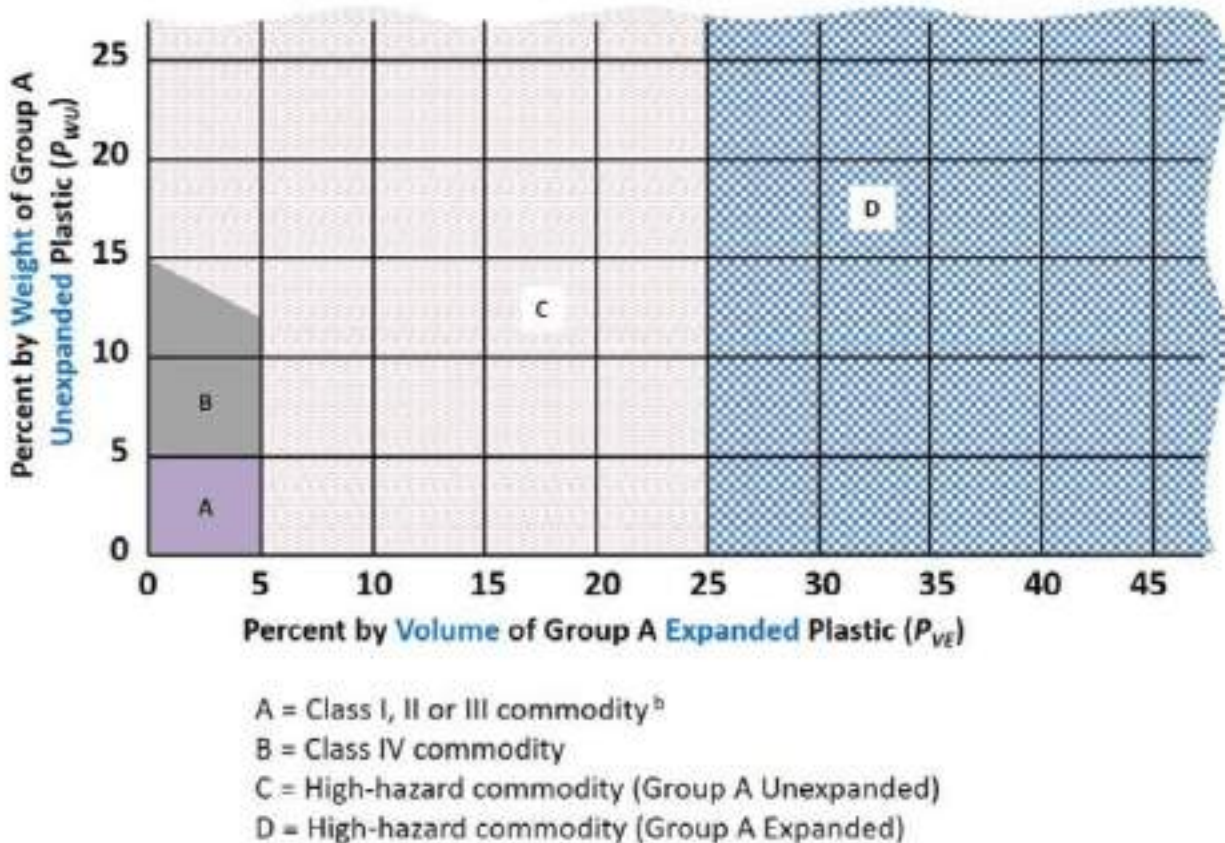

FIGURE 3203.9(2)
EVALUATION BY WEIGHT OF GROUP A EXPANDED PLASTICS IN MIXED COMMODITIES^{a, b, c}

Reason:

During the 2018 IFC code cycle, the FCAC Ch 32 working group submitted changes to these tables that to correlate closer with the 2016 NFPA 13. These changes adjust the tables in the 2021 IFC to match the 2019 edition of NFPA 13. The only difference from the IFC to NFPA 13 are the amounts of plastic in Class I and II plastics. The IFC will permit small amount of plastic in Class I and II commodities whereas NFPA 13 moves any Class I or II commodity with any amount of plastic into a Class III commodity. The FCAC justifies the small amount of plastic in Class I and II commodities to accomodate for existing systems and new systems.

This proposal is submitted by the ICC Fire Code Action Committee (FCAC). The FCAC was established by the ICC Board of Directors to pursue opportunities to improve and enhance assigned International Codes with regard to fire safety and hazardous materials in new and existing buildings and facilities and the protection of life and property in wildland urban interface areas. In 2017 the Fire-CAC has held 3 open meetings. In addition, there were numerous conference calls, Regional Work Group and Task Group meetings for the current code development cycle, which included members of the committees as well as any interested parties, to discuss and debate the proposed changes. Related documentation and reports are posted on the FCAC website at: <https://www.iccsafe.org/codes-tech-support/cs/fire-code-action-committee-fcac/>

Cost Impact

The code change proposal will decrease the cost of construction .

The IFC will allow small amounts of plastic in Class I and II commodities. This will lower fire protection costs (design, water supply, etc) versus designing to NFPA 13, which classifies any amount of plastic as a Class III commodity.

F253-18

IFC: 3205.1 (New)

Proponent: Jeffrey Hugo, representing National Fire Sprinkler Association (hugo@nfsa.org)

2018 International Fire Code

Add new text as follows:

3205.1 Storage layout plan maintenance. The approved storage layout shall be verified and evaluated annually in accordance with Section 3201.3.2. Modifications or changes to the provisions of the approved storage layout shall not be made without prior approval of the fire code official.

Reason:

In the 2018 IFC, FCAC included a nine-item list and floor plan placard requirement for high-piled storage in Section 3201.3.2. This proposal correlates this new requirement to the housekeeping and maintenance section in 3205.

The storage layout floor plan in 3201.3.2 includes the following, 1) location and dimension of racks, 2) design storage height, 3) types of commodities, 4) commodity clearances, 5) aisle dimensions, 6) pile volume, 7) location and classification of commodities, 8) location of fire department access doors and 9) location of water supply valves. While these items are on a floor plan installed on new projects, there is essentially no follow up to verify that the floor plan remains or the items contained within are maintained or followed to the degree that this section on housekeeping exists.

This proposal does take the requirements in Section 3205 further by:

1. requiring a annual inspection to verify the floor plan placard still exists and to evaluate the floor plan contents to the actual storage conditions. An annual inspection could correlate with an operational permit, or other annual inspections (that exist throughout the fire code).
2. triggers checking with the fire code official is made prior to any modifications to the floor plan. This is similar to other plans (such as lease plans, door removals, etc.) that adds an additional level of communication between the storage management and the local fire code official.

Cost Impact

The code change proposal will not increase or decrease the cost of construction .

Correlating. The layout storage plan is expected to be maintained.

Internal ID: 1482

F254-18

IFC: 3205.4

Proponent: Mark Chubb, Telgian Corp., representing Telgian Corp. (mchubb@telgian.com)

2018 International Fire Code

Add new text as follows:

3205.4 Aisle maintenance. When restocking is not being conducted, aisles shall be kept clear of storage, waste material and debris. Fire department access doors, aisles and *exit* doors shall not be obstructed. During restocking operations using manual stocking methods, a minimum unobstructed aisle width of 24 inches (610 mm) shall be maintained in 48-inch (1219 mm) or smaller aisles, and a minimum unobstructed aisle width of one-half of the required aisle width shall be maintained in aisles greater than 48 inches (1219 mm). During mechanical stocking operations, a minimum unobstructed aisle width of 44 inches (1118 mm) shall be maintained in accordance with Section 3206.10.

Exception: In high-piled combustible storage protected by automatic sprinkler systems designed and installed to deliver 0.60 gpm/sq ft over the most remote 2,000 sq ft and not less than 0.70 gpm/sq ft from the four most demanding sprinklers in accordance with 903.3.1.1, displays and wing stacks not exceeding 48-inches in height provided they do not obstruct or reduce the clear width of the aisle to less than 48-inches...

Reason:

The proposed exception recognizes and incorporates language consistent with the provisions of NFPA 13--2016, 20.3.1(13), which represent the most prevalent fire protection design criteria for many big box retail facilities. Extensive large-scale fire testing demonstrates that such displays do not compromise the effectiveness of sprinkler systems to control or extinguish fires in high-piled combustible storage when sprinkler systems satisfy these criteria.

Bibliography:

NFPA 13, Standard for the Installation of Sprinkler Systems, 2016 edition. Quincy, MA: National Fire Protection Association.

Cost Impact

The code change proposal will not increase or decrease the cost of construction .

Although the proposed change will not increase or decrease the cost of construction, it will facilitate operations that increase retail revenue in facilities that satisfy the specified fire protection design criteria.

Internal ID: 445

F256-18

IFC: TABLE 3206.2

Proponent: Michael O'Brian, Chair, representing FCAC (fcac@iccsafe.org)

2018 International Fire Code

Revise as follows:

**TABLE 3206.2
GENERAL FIRE PROTECTION AND LIFE SAFETY REQUIREMENTS**

COMMODITY CLASS	SIZE OF HIGH-PILED STORAGE AREA ^a (square feet) (see Sections 3206.2 and 3206.3)	ALL STORAGE AREAS (See Sections 3206, 3207 and 3208) ^b				SOLID-PILED STORAGE, SHELF STORAGE AND PALLETIZED STORAGE (see Section 3207.3)		
		Automatic fire-extinguishing system (see Section 3206.4)	Fire detection system (see Section 3206.5)	Fire department access doors (see Section 3206.7)	Smoke and heat removal (see Section 3206.8)	Maximum pile dimension ^c (feet)	Maximum permissible storage height ^d (feet)	Maximum pile volume (cubic feet)
H-V	0-500	Not Required ^e	Not Required	Not Required	Not Required	Not Required	Not Required	Not Required
	501-2,500	Not Required ^e	Yes ^e	Not Required	Not Required	120	40	100,000
	2,501-12,000 Open to the public	Yes	Not Required	Not Required	Not Required	120	40	400,000
	2,501-12,000 Not open to the public (Option 1)	Yes	Not Required	Not Required ^e	Not Required	120	40	400,000
	2,501-12,000 Not open to the public (Option 2)	Not Required ^e	Yes	Yes	Yes ^{h, i}	120	30 ^e	200,000
	12,001-500,000	Yes	Not Required	Yes	Yes ^{h, i}	120	40	400,000
	Greater than 500,000	Yes	Not Required	Yes	Yes ^{h, i}	120	40	400,000
High hazard	0-500	Not Required ^e	Not Required	Not Required ^e	Not Required	60	Not Required	Not Required
	501-2,500 Open to the public	Yes	Not Required	Not Required ^e	Not Required	60	30	75,000
	501-2,500 Not open to the public (Option 1)	Yes	Not Required	Not Required ^e	Not Required	60	30	75,000
	501-2,500 Not open to the public (Option 2)	Not Required ^e	Yes ^f	Yes	Yes ^{h, i}	60	20	50,000
	2,501-300,000	Yes	Not Required	Yes	Yes ^{h, i}	60	30	75,000
	Greater than 300,000 ^f	Yes	Not Required	Yes	Yes ^{h, i}	60	30	75,000

For SI: 1 foot = 304.8 mm, 1 cubic foot = 0.02832 m³ , 1 square foot = 0.0929 m².

- a. Where automatic sprinklers are required for reasons other than those in Chapter 32, the portion of the sprinkler system protecting the high-piled storage area shall be designed and installed in accordance with Sections 3207 and 3208.
- b. For aisles, see Section 3206.10.
- c. Piles shall be separated by aisles complying with Section 3206.10.
- d. For storage in excess of the height indicated, special fire protection shall be provided in accordance with Note f where required by the fire code official. See Chapters 51 and 57 for special limitations for aerosols and flammable and combustible liquids, respectively.
- e. For storage exceeding 30 feet in height, Option 1 shall be used.
- f. Special fire protection provisions including, but not limited to, fire protection of exposed steel columns; increased sprinkler density; additional in-rack sprinklers, without associated reductions in ceiling sprinkler density; or ~~additional~~ fire department hose connections shall be provided where required by the fire code official.
- g. Not required where an automatic fire-extinguishing system is designed and installed to protect the high-piled storage area in accordance with Sections 3207 and 3208.
- h. Not required where storage areas are protected by either early suppression fast response (ESFR) sprinkler systems or control mode special application sprinklers with a response time index of 50 (m • s)^{1/2} or less that are listed to control a fire in the stored commodities with 12 or fewer sprinklers, installed in accordance with NFPA 13.
- i. Not required in frozen food warehouses used solely for storage of Class I and II commodities where protected by an approved automatic sprinkler system.

Reason:

For high-hazard commodities in large (300,000-500,000 sq. ft.) the code gives the code official broad latitude to require “special fire protection provisions.” The change clarifies that the code official may require approved hose station outlets of any size and in any location he or she feels is necessary in accordance with the stored commodity.

Earlier editions of the International Fire Code included requirements for host stations in rack storage arrays. The existing language: “additional” fire department hose connections implies they may be required and were editorially omitted.

This proposal is submitted by the ICC Fire Code Action Committee (FCAC). The FCAC was established by the ICC Board of Directors to pursue opportunities to improve and enhance assigned International Codes with regard to fire safety and hazardous materials in new and existing buildings and facilities and the protection of life and property in wildland urban interface areas. In 2017 the Fire-CAC has held 3 open meetings. In addition, there were numerous conference calls, Regional Work Group and Task Group meetings for the current code development cycle, which included members of the committees as well as any interested parties, to discuss and debate the proposed changes. Related documentation and reports are posted on the FCAC website at: <https://www.iccsafe.org/codes-tech-support/cs/fire-code-action-committee-fcac/>

Cost Impact

The code change proposal will decrease the cost of construction .

This change decreases the cost of construction from arbitrarily adding hose connections.

Internal ID: 790

F258-18

IFC: 3206.3.1

Proponent: Kevin Scott, representing KH Scott & Associates LLC (khscottassoc@gmail.com)

2018 International Fire Code

Revise as follows:

3206.3.1 Size of high-piled storage area. The size of each *high-piled storage area* shall include the footprint of the actual high-piled storage racks, shelves or piles and the following aisles:

1. Interior aisles within the footprint of the storage area.
2. An aisle around the perimeter of the footprint with a minimum width as required in Section 3206.10.1 or the dimension to a ~~wall~~ or full height wall, whichever is less.

Reason:

This proposal revises Item 2 to specify that the dimension referenced to a full height wall rather than a partial height wall. Even though the section does not state "partial height wall", when it lists "wall or full height wall" it can mistakenly be misapplied to a partial height wall. Removing this term will eliminate the potential confusion.

Cost Impact

The code change proposal will not increase or decrease the cost of construction .

Clarification with no change in code requirements.

Internal ID: 2351

F259-18

IFC: 3208.1.1 (New)

Proponent: Michael O'Brian, Chair, representing FCAC (fcac@iccsafe.org)

2018 International Fire Code

Add new text as follows:

3208.1.1 Storage Racks. The design and installation of storage racks shall be in accordance with the International Building Code.

Reason:

The change proposal is intended to correlate the IFC to the IBC provisions for steel storage racks. Rack systems installed without considering the design load or anchoring of the structural system can present a collapse hazard to building occupants and emergency responders. Racks without anchors can be overturned, causing collapse of stored pallet loads and the rack structure.

The design, erection and anchoring of steel storage racks constructed from cold-rolled and hot-rolled steel is regulated in Chapters 17 (Special Inspections) and 22 (Steel) of the IBC. Section 2209 requires the design of rack systems comply with Rack Manufacturers Institute MH16.1-08, "Specification for Design, Testing and Utilization of Industrial Steel Racks", an ANSI compliant standard. This standard establishes requirements for the design of the racks to resist gravity loads and external loads such as seismic events. The standard also requires an evaluation of the building foundation to determine it can support the design loads and provide sufficient strength for anchoring. A permanent plaque on each rack is required that indicates the maximum allowable load for each rack tier.

ANSI/MH 16.1 requires the rack owner to maintain the racks in accordance with the approved design and Section 1.4. This section addresses rack loading, proper load placement on the rack, maintaining pallets, and replacement of damaged rack components. The installation of concrete anchors requires a Special Inspection in accordance with IBC Table 1705.3. It is important to recognize that item 4 in IBC Table 1705.3 prescribes that anchors installed in hardened concrete members require evaluation for compliance with American Concrete Institute 335.2, Qualification of Post-Installed Mechanical Anchors in Concrete & Commentary. Compliance is achieved in the IBC when the designer specifies anchors that have been evaluated by and received an evaluation report from ICC Evaluation Services.

The provision provides the Fire Code Official with a mechanism for dealing with rack installations that are installed without a building permit. The provisions in RMI MH16.1 also establishes maximum deflection limits that can be used to determine if a rack is overloaded and establishes requirements mandating the owner maintain the rack in accordance with the standard.

This proposal is submitted by the ICC Fire Code Action Committee (FCAC). The FCAC was established by the ICC Board of Directors to pursue opportunities to improve and enhance assigned International Codes with regard to fire safety and hazardous materials in new and existing buildings and facilities and the protection of life and property in wildland urban interface areas. In 2017 the Fire-CAC has held 3 open meetings. In addition, there were numerous conference calls, Regional Work Group and Task Group meetings for the current code development cycle, which included members of the committees as well as any interested parties, to discuss and debate the proposed changes. Related documentation and reports are posted on the FCAC website at: <https://www.iccsafe.org/codes-tech-support/cs/fire-code-action-committee-fcac/>

Cost Impact

The code change proposal will not increase or decrease the cost of construction .

Proposal is meant for correlation between IFC and IBC.

Internal ID: 788

F260-18

IFC: 3209.4, 3209.4.1 (New), 3209.4.2 (New)

Proponent: Michael O'Brian, Chair, representing FCAC (fcac@iccsafe.org)

2018 International Fire Code

Revise as follows:

3209.4 Automated rack storage. *High-piled storage areas with greater than 500 square feet (46m²) of automated rack storage shall be provided with a manually activated emergency shutdown switch for use by emergency personnel. The switch shall be clearly identified and shall be in a location approved by the fire code official. and automatic shutdown in accordance with Sections 3209.4.1 and 3209.4.2.*

Add new text as follows:

3209.4.1 Manual Activated Shut Down. A manually activated switch shall be provided to initiate the approved automatic shutdown process. The switch shall be clearly identified and shall be in a location approved by the fire code official.

3209.4.2 Automatic Shut Down. The approved automatic shutdown process shall commence upon any of the following events:

1. Water flow is detected in the automatic sprinkler system, if present.
2. Activation of the fire detection system, if present.

Reason:

This proposal breaks down the charging language into two subsections and adds the option for an automatic shutdown process for automated storage. The approved manual or automatic shutdown process is left to each code official but the term "approved" and "process" here allows for each shutdown to cycle the automated system to a safe place.

This proposal is submitted by the ICC Fire Code Action Committee (FCAC). The FCAC was established by the ICC Board of Directors to pursue opportunities to improve and enhance assigned International Codes with regard to fire safety and hazardous materials in new and existing buildings and facilities and the protection of life and property in wildland urban interface areas. In 2017 the Fire-CAC has held 3 open meetings. In addition, there were numerous conference calls, Regional Work Group and Task Group meetings for the current code development cycle, which included members of the committees as well as any interested parties, to discuss and debate the proposed changes. Related documentation and reports are posted on the FCAC website at: <https://www.iccsafe.org/codes-tech-support/cs/fire-code-action-committee-fcac/>

Cost Impact

The code change proposal will decrease the cost of construction .

Each automated facility has shut down processes. This proposal allows the code official to be involved in the approval of the shutdown process.

Internal ID: 188

F261-18

IFC: 3210.1, 3210.1.1 (New), TABLE 903.2.11.6, Chapter 80

Proponent: Jeffrey Hugo, representing National Fire Sprinkler Association (hugo@nfsa.org)

2018 International Fire Code

Revise as follows:

3210.1 General. Records storage facilities used for the rack or shelf storage of combustible paper records greater than 12 feet (3658 mm) in height shall be in accordance with Sections 3206 and ~~3208~~ and ~~NFPA 13~~. 3208. Palletized storage of records shall be in accordance with Section 3207.

Add new text as follows:

3210.1.1 Fire Protection. The design and installation of the automatic sprinkler system shall be in accordance with NFPA 13 and NFPA 232.

Revise as follows:

**TABLE 903.2.11.6
ADDITIONAL REQUIRED FIRE SUPPRESSION SYSTEMS**

SECTION	SUBJECT
914.2.1	Covered and open mall buildings
914.3.1	High-rise buildings
914.4.1	Atriums
914.5.1	Underground structures
914.6.1	Stages
914.7.1	Special amusement buildings
914.8.2	Airport traffic control towers
914.8.3, 914.8.6	Aircraft hangars
914.9	Flammable finishes
914.10	Drying rooms
914.11.1	Ambulatory care facilities
1029.6.2.3	Smoke-protected assembly seating
1103.5.1	Existing Group A occupancies
1103.5.2	Pyroxylin plastic storage in existing buildings
1103.5.3	Existing Group I-2 occupancies
1103.5.4	Existing Group I-2, Condition 2 occupancies
1103.5.4	Pyroxylin plastics
2108.2	Dry cleaning plants
2108.3	Dry cleaning machines
2309.3.2.6.2	Hydrogen motor fuel-dispensing area canopies
2404.2	Spray finishing in Group A, E, I or R
2404.4	Spray booths and spray rooms
2405.2	Dip-tank rooms in Group A, I or R
2405.4.1	Dip tanks
2405.9.4	Hardening and tempering tanks
2703.10	HPM facilities
2703.10.1.1	HPM work station exhaust
2703.10.2	HPM gas cabinets and exhausted enclosures
2703.10.3	HPM exit access corridor
2703.10.4	HPM exhaust ducts
2703.10.4.1	HPM noncombustible ducts
2703.10.4.2	HPM combustible ducts
2807.3	Lumber production conveyor enclosures
2808.7	Recycling facility conveyor enclosures
3006.1	Class A and B ovens
3006.2	Class C and D ovens
Table 3206.2	Storage fire protection
3206.4	Storage
<u>3210.1.1</u>	<u>Record storage over 12 feet.</u>
3704.5	Storage of more than 1,000 cubic feet of loose combustible fibers
5003.8.4.1	Gas rooms
5003.8.5.3	Exhausted enclosures
5004.5	Indoor storage of hazardous materials
5005.1.8	Indoor dispensing of hazardous materials
5104.4.1	Aerosol product warehouses
5106.3.2	Aerosol display and merchandising areas

5306.2.1	Exterior medical gas storage room
5306.2.2	Interior medical gas storage room
5306.2.3	Medical gas storage cabinet
5606.5.2.1	Storage of smokeless propellant
5606.5.2.3	Storage of small arms primers
5704.3.7.5.1	Flammable and combustible liquid storage rooms
5704.3.8.4	Flammable and combustible liquid storage warehouses
5705.3.7.3	Flammable and combustible liquid Group H-2 or H-3 areas
6004.1.2	Gas cabinets for highly toxic and toxic gas
6004.1.3	Exhausted enclosures for highly toxic and toxic gas
6004.2.2.6	Gas rooms for highly toxic and toxic gas
6004.3.3	Outdoor storage for highly toxic and toxic gas
6504.1.1	Pyroxylin plastic storage cabinets
6504.1.3	Pyroxylin plastic storage vaults
6504.2	Pyroxylin plastic storage and manufacturing

For SI: 1 cubic foot = 0.023 m³.

Add new standard(s) follows:

NFPA

National Fire Protection Association
1 Batterymarch Park
Quincy MA 02169-7471

232--17:

Standard for the Protection of Records

Reason:

NFPA 232 is a new referenced standard for the IFC. Adding NFPA 232 provides additional criteria for records storage that is not addressed by the IFC. This reference is needed for a path to get to NFPA 232, as it is not a referenced standard through NFPA 13.

Bibliography:

Standard for the Protection of Records, NFPA 232, 2017, www.nfpa.org/232

Cost Impact

The code change proposal will not increase or decrease the cost of construction .

Correlation to correct standard.

Analysis: A review of the standard proposed for inclusion in the code, NFPA 232--17 Standard for the Protection of Records, with regard to the ICC criteria for referenced standards (Section 3.6 of CP#28) will be posted on the ICC website on or before April 2, 2018.

Internal ID: 799

F262-18 Part I

IFC: Chapter 33

Proponent: Paul Coats, American Wood Council, representing American Wood Council (pcoats@awc.org)

THIS IS A 2 PART CODE CHANGE PROPOSAL. PART I WILL BE HEARD THE IFC COMMITTEE, PART II WILL BE HEARD BY THE IBC-G COMMITTEE. PLEASE SEE THE TENTATIVE HEARING ORDERS FOR THE RESPECTIVE COMMITTEES.

2018 International Fire Code

CHAPTER 33 FIRE SAFETY DURING CONSTRUCTION AND DEMOLITION

SECTION 3301 GENERAL

3301.1 Scope. This chapter shall apply to structures in the course of construction, *alteration* or demolition, including those in underground locations. ~~Compliance with NFPA 241 is required for items not specifically addressed herein.~~

3301.2 Purpose. This chapter prescribes minimum safeguards for construction, *alteration* and demolition operations to provide reasonable safety to life and property from fire during such operations.

3302 REQUIREMENTS

3302.1 Requirements. Fire safety during construction and demolition shall be in accordance with Chapter 33 of the International Building Code. Compliance with NFPA 241 is required for items not specifically addressed therein.

Delete without substitution:

~~**SECTION 3302 DEFINITIONS**~~

~~**SECTION 3303 TEMPORARY HEATING EQUIPMENT**~~

~~**SECTION 3304 PRECAUTIONS AGAINST FIRE**~~

~~**SECTION 3305 FLAMMABLE AND COMBUSTIBLE LIQUIDS**~~

~~**SECTION 3306 FLAMMABLE GASES**~~

~~**SECTION 3307 EXPLOSIVE MATERIALS**~~

~~**SECTION 3308 OWNER'S RESPONSIBILITY FOR FIRE PROTECTION**~~

~~**SECTION 3309 FIRE REPORTING**~~

~~**SECTION 3310 ACCESS FOR FIRE FIGHTING**~~

~~**SECTION 3311 MEANS OF EGRESS**~~

~~**SECTION 3312 WATER SUPPLY FOR FIRE PROTECTION**~~

~~**SECTION 3313 STANDPIPES**~~

~~**SECTION 3314 AUTOMATIC SPRINKLER SYSTEM**~~

~~**SECTION 3315 PORTABLE FIRE EXTINGUISHERS**~~

~~**SECTION 3316 MOTORIZED CONSTRUCTION EQUIPMENT**~~

~~**SECTION 3317 SAFEGUARDING ROOFING OPERATIONS**~~

Analysis: NFPA 56 and NFPA 241 are already referenced in the I-codes. Note that there has been erratum that changed the edition of NFPA 241 referenced in the 2018 IFC to the 2013 edition.

F262-18 Part II

IBC: Chapter 33, 3301.1, 3301.2, 3302.3, 3303.7, 3309, 3310, 3311, 3312, 3313, 3314, 3315 (New), 3316(New), 322(New), 3323 (New), Chapter 35

Proponent: Paul Coats, American Wood Council, representing American Wood Council (pcoats@awc.org)

2018 International Building Code

Revise as follows:

CHAPTER 33 SAFEGUARDS AND FIRE PREVENTION DURING CONSTRUCTION

SECTION 3301 GENERAL

3301.1 Scope. The provisions of this chapter shall govern safety during construction, alteration, and demolition operations, including structures in underground locations, and the protection of adjacent public and private properties. Compliance with NFPA 241 is required for items not specifically addressed herein.

3301.2 Purpose. This chapter prescribes minimum safeguards for construction, alteration and demolition operations, including minimum safeguards to provide reasonable safety to life and property from fire during such operations.

~~**3301.2**~~**3301.3 Storage and placement.** Construction equipment and materials shall be stored and placed so as not to endanger the public, the workers or adjoining property for the duration of the construction project.

SECTION 3302 CONSTRUCTION SAFEGUARDS

~~**3302.3 Fire safety during construction.** Fire safety during construction shall comply with the applicable requirements of this code and the applicable provisions of Chapter 33 of the International Fire Code.~~

SECTION 3303 DEMOLITION

Delete without substitution:

~~**3303.7 Fire safety during demolition.** Fire safety during demolition shall comply with the applicable requirements of this code and the applicable provisions of Chapter 33 of the International Fire Code.~~

SECTION 3309 TEMPORARY HEATING EQUIPMENT

Add new text as follows:

3309.1 Listed. Temporary heating devices shall be listed and labeled. The installation, maintenance and use of temporary heating devices shall be in accordance with the listing and the manufacturer's instructions.

3309.2 Oil-fired heaters. Oil-fired heaters shall comply with Section 603 of the International Fire Code.

3309.3 LP-gas heaters. Fuel supplies for liquefied-petroleum gas-fired heaters shall comply the International Fuel Gas Code and Chapter 61 of the International Fire Code.

3309.4 Refueling. Refueling operations for liquid-fueled equipment or appliances shall be conducted in accordance with Section 5705 of the International Fire Code. The equipment or appliance shall be allowed to cool prior to refueling.

3309.5 Installation. Clearance to combustibles from temporary heating devices shall be maintained in accordance with the labeled equipment. When in operation, temporary heating devices shall be fixed in place and protected from damage, dislodgement or overturning in accordance with the manufacturer's instructions.

3309.6 Supervision. The use of temporary heating devices shall be supervised and maintained only by competent personnel.

SECTION 3310 PRECAUTIONS AGAINST FIRE

3310.1 Smoking. Smoking shall be prohibited except in areas approved by the fire code official. Signs shall be posted in accordance with Section 310 of the International Fire Code. In areas approved by the fire code official where

smoking is permitted, ashtrays approved by the fire code official shall be provided in accordance with Section 310 of the International Fire Code.

3310.2 Combustible debris, rubbish and waste. Combustible debris, rubbish and waste material shall comply with the requirements of Sections 3310.2.1 through 3310.2.4.

3310.2.1 Combustible waste material accumulation. Combustible debris, rubbish and waste material shall not be accumulated within buildings.

3310.2.2 Combustible waste material removal. Combustible debris, rubbish and waste material shall be removed from buildings at the end of each shift of work.

3310.2.3 Rubbish containers. Where rubbish containers with a capacity exceeding 5.33 cubic feet (40 gallons) (0.15 m³) are used for temporary storage of combustible debris, rubbish and waste material, they shall have tightfitting or self-closing lids. Such rubbish containers shall be constructed entirely of materials that comply with either of the following:

1. Noncombustible materials.
2. Materials that meet a peak rate of heat release not exceeding 300 kW/m² when tested in accordance with ASTM E1354 at an incident heat flux of 50 kW/m² in the horizontal orientation.

3310.2.4 Spontaneous ignition. Materials susceptible to spontaneous ignition, such as oily rags, shall be stored in a listed disposal container.

3310.3 Burning of combustible debris, rubbish and waste. Combustible debris, rubbish and waste material shall not be disposed of by burning on the site unless approved by the fire code official.

3310.4 Open burning. Open burning shall comply with Section 307 of the International Fire Code.

3310.5 Fire watch. Where required by the fire code official or the prefire plan established in accordance with Section 3314.3, a fire watch shall be provided for building demolition and for building construction that is hazardous in nature, such as temporary heating or hot work.

3310.5.1 Fire watch during construction. Where required by the fire code official, a fire watch shall be provided during nonworking hours for new construction that exceeds 40 feet (12 192 mm) in height above the lowest adjacent grade.

3310.5.2 Fire watch personnel. Trained personnel shall be provided to serve as an on-site fire watch. Fire watch personnel shall be provided with not fewer than one means for notification of the fire department which is acceptable to the fire code official, and the sole duty of such personnel shall be to perform constant patrols and watch for the occurrence of fire. The combination of fire watch duties and site security duties is acceptable. Fire watch personnel shall be trained in the use of portable fire extinguishers.

3310.5.3 Fire watch location and records. The fire watch shall include areas specified by the prefire plan established in accordance with Section 3314.3. The fire watch personnel shall keep a record of all time periods of duty, including a log entry each time the site was patrolled and each time a structure under construction was entered and inspected. The records and log entries shall be made available for review by the fire code official upon request.

3310.6 Cutting and welding. Welding, cutting, open torches and other hot work operations and equipment shall comply with Chapter 35 of the International Fire Code.

3310.7 Electrical. Temporary wiring for electrical power and lighting installations used in connection with the construction, alteration or demolition of buildings, structures, equipment or similar activities shall comply with NFPA 70.

3310.8 Cooking. Cooking shall be prohibited except in designated cooking areas approved by the fire code official. Signs with a minimum letter height of 3 inches (76 mm) and a minimum brush stroke of 1/2 inch (13 mm) shall be posted in conspicuous locations in designated cooking areas and state:

DESIGNATED COOKING AREA

COOKING OUTSIDE OF A DESIGNATED COOKING

AREA IS PROHIBITED

SECTION 3311 FLAMMABLE AND COMBUSTIBLE LIQUIDS

3311.1 Storage of flammable and combustible liquids. Storage of flammable and combustible liquids shall be in accordance with Section 5704 of the International Fire Code.

3311.2 Class I and Class II liquids. The storage, use and handling of flammable and combustible liquids at construction sites shall be in accordance with Section 5706.2 of the International Fire Code. Ventilation shall be provided for operations involving the application of materials containing flammable solvents.

3311.3 Housekeeping. Flammable and combustible liquid storage areas shall be maintained clear of combustible vegetation and waste materials. Such storage areas shall not be used for the storage of combustible materials.

3311.4 Precautions against fire. Sources of ignition and smoking shall be prohibited in flammable and combustible liquid storage areas. Signs shall be posted in accordance with Section 310 of the International Fire Code.

3311.5 Handling at point of final use. Class I and II liquids shall be kept in safety containers approved by the fire code official.

3311.6 Leakage and spills. Leaking vessels shall be immediately repaired or taken out of service and spills shall be cleaned up and disposed of properly.

SECTION 3312 FLAMMABLE GASES

3312.1 Storage and handling. The storage, use and handling of flammable gases shall comply with Chapter 58 of the International Fire Code.

3312.2 Cleaning with flammable gas. Flammable gases shall not be used to clean or remove debris from piping open to the atmosphere.

3312.2.1 Pipe cleaning and purging. The cleaning and purging of flammable gas piping systems, including cleaning new or existing piping systems, purging piping systems into service and purging piping systems out of service, shall comply with NFPA 56.

Exceptions:

1. Compressed gas piping systems other than fuel gas piping systems where in accordance with Chapter 53 of the International Fire Code.
2. Piping systems regulated by the International Fuel Gas Code.
3. Liquefied petroleum gas systems in accordance with Chapter 61 of the International Fire Code.

SECTION 3313 EXPLOSIVE MATERIALS

3313.1 Storage and handling. Explosive materials shall be stored, used and handled in accordance with Chapter 56 of the International Fire Code.

3313.2 Supervision. Blasting operations shall be conducted in accordance with Chapter 56 of the International Fire Code.

3313.3 Demolition using explosives. Fire hoses approved by the fire code official for use by demolition personnel shall be maintained at the demolition site wherever explosives are used for demolition. Such fire hoses shall be connected to an water supply approved by the fire code official and shall be capable of being brought to bear on post-detonation fires anywhere on the site of the demolition operation.

SECTION 3314 OWNER'S RESPONSIBILITY FOR FIRE PROTECTION

3314.1 Program development and maintenance. The owner or owner's authorized agent shall be responsible for the development, implementation and maintenance of a written plan establishing a fire prevention program at the project site applicable throughout all phases of the construction, repair, alteration or demolition work. The plan shall address the requirements of this chapter and other applicable portions of this code, the duties of staff, and staff training requirements. The plan shall be made available for review by the fire code official upon request.

3314.2 Program superintendent. The owner shall designate a person to be the fire prevention program

superintendent who shall be responsible for the fire prevention program and ensure that it is carried out through completion of the project. The fire prevention program superintendent shall have the authority to enforce the provisions of this chapter and other provisions as necessary to secure the intent of this chapter. Where guard service is provided in accordance with NFPA 241, the superintendent shall be responsible for the guard service.

3314.3 Prefire plans. The fire prevention program superintendent shall develop and maintain an prefire plan approved by the fire code official and in cooperation with the fire chief. The fire chief and the fire code official shall be notified of changes affecting the utilization of information contained in such prefire plans.

3314.4 Training. Training of responsible personnel in the use of fire protection equipment shall be the responsibility of the fire prevention program superintendent. Records of training shall be kept and made a part of the written plan for the fire prevention program.

3314.5 Fire protection devices. The fire prevention program superintendent shall determine that all fire protection equipment is maintained and serviced in accordance with this code. The quantity and type of fire protection equipment shall be approved by the fire code official. Fire protection equipment shall be inspected in accordance with the fire protection program.

3314.6 Hot work operations. The fire prevention program superintendent shall be responsible for supervising the permit system for hot work operations in accordance with Chapter 35 of the International Fire Code.

3314.7 Impairment of fire protection systems. Impairments to any fire protection system shall be in accordance with Section 901 of the International Fire Code.

3314.7.1 Smoke detectors and smoke alarms. Smoke detectors and smoke alarms located in an area where airborne construction dust is expected shall be covered to prevent exposure to dust or shall be temporarily removed. Smoke detectors and alarms that were removed shall be replaced upon conclusion of dust-producing work. Smoke detectors and smoke alarms that were covered shall be inspected and cleaned, as necessary, upon conclusion of dust-producing work.

3314.8 Temporary covering of fire protection devices. Coverings placed on or over fire protection devices to protect them from damage during construction processes shall be immediately removed upon the completion of the construction processes in the room or area in which the devices are installed.

SECTION 3315 FIRE REPORTING

3315.1 Emergency telephone. Emergency telephone facilities with ready access shall be provided in an a location approved by the fire code official at the construction site, or an equivalent means of communication approved by the fire code official shall be provided. The street address of the construction site and the emergency telephone number of the fire department shall be posted adjacent to the telephone. Alternatively, where an equivalent means of communication has been approved by the fire code official, the site address and fire department emergency telephone number shall be posted at the main entrance to the site, in guard shacks and in the construction site office.

SECTION 3316 ACCESS FOR FIRE FIGHTING

3316.1 Required access. Vehicle access approved by the fire code official for firefighting shall be provided to all construction or demolition sites. Vehicle access shall be provided to within 100 feet (30 480 mm) of temporary or permanent fire department connections. Vehicle access shall be provided by either temporary or permanent roads, capable of supporting vehicle loading under all weather conditions. Vehicle access shall be maintained until permanent fire\ apparatus access roads are available.

3316.2 Key boxes. Key boxes shall be provided as required by Chapter 5 of the International Fire Code.

SECTION 3309-3317 FIRE EXTINGUISHERS

[F] 3309-13317.1 Where required. Structures under construction, alteration or demolition shall be provided with not fewer than one ~~approved~~ portable fire extinguisher in accordance with Section 906, approved by the building official and the fire code official, and sized for not less than ordinary hazard as follows:

1. At each *stairway* on all floor levels where combustible materials have accumulated.
2. In every storage and construction shed.

3. Additional portable fire extinguishers shall be provided where special hazards exist, such as the storage and use of flammable and combustible liquids.

Delete without substitution:

~~[F] 3309.2 Fire hazards.~~ The provisions of this code and the International Fire Code shall be strictly observed to safeguard against all fire hazards attendant upon construction operations.

SECTION 3310-3318 MEANS OF EGRESS

~~3310.13318.1 Stairways required.~~ Where building construction exceeds 40 feet (12 192 mm) in height above the lowest level of fire department vehicle access, a temporary or permanent *stairway* shall be provided. As construction progresses, such *stairway* shall be extended to within one floor of the highest point of construction having secured decking or flooring.

~~[F] 3310.23318.2 Maintenance of means of egress.~~ ~~Means Required~~ *means of egress* and required accessible *means of egress* shall be maintained at all times during construction, demolition, remodeling or *alterations* and *additions* to any building.

Exception: Existing *means of egress* need not be maintained where approved

temporary *means of egress* and temporary accessible means of egress systems and facilities, approved by the building official and the fire code official, are provided.

SECTION 3311-3319 STANDPIPES

~~[F] 3311.13319.1 Where required.~~ In buildings required to have standpipes by Section 905.3.1, not fewer than one standpipe shall be provided for use during construction. Such standpipes shall be installed prior to construction exceeding 40 feet (12 192 mm) in height above the lowest level of fire department vehicle access. Such standpipes shall be provided with fire department hose connections at locations adjacent to *stairways* complying with Section ~~3310.1-3318.1.~~ As construction progresses, such standpipes shall be extended to within one floor of the highest point of construction having secured decking or flooring.

~~[F] 3311.23319.2 Buildings being demolished.~~ Where a building is being demolished and a standpipe exists within such a building, such standpipe shall be maintained in an operable condition so as to be available for use by the fire department. Such standpipe shall be demolished with the building but shall not be demolished more than one floor below the floor being demolished.

~~[F] 3311.33319.3 Detailed requirements.~~ Standpipes shall be installed in accordance with the provisions of Chapter 9.

Exception: Standpipes shall be either temporary or permanent in nature, and with or without a water supply, provided that such standpipes conform to the requirements of Section 905 as to capacity, outlets and materials.

SECTION 3312-3320 AUTOMATIC SPRINKLER SYSTEM

~~[F] 3312.13320.1 Completion before occupancy.~~ In buildings where an *automatic sprinkler system* is required by this code or the International Fire Code, it shall be unlawful to occupy any portion of a building or structure until the *automatic sprinkler system* installation has been tested and approved by the building and fire code official, except as provided in Section ~~111.3-111.3~~ of this code or Section 105.3.4 of the International Fire Code.

~~[F] 3312.23320.2 Operation of valves.~~ Operation of sprinkler control valves shall be permitted only by properly authorized personnel and shall be accompanied by notification of duly designated parties. When the sprinkler protection is being regularly turned off and on to facilitate connection of newly completed segments, the sprinkler control valves shall be checked at the end of each work period to ascertain that protection is in service.

SECTION 3313-3321 WATER SUPPLY FOR FIRE PROTECTION

~~[F] 3313.13321.1 Where required.~~ ~~An~~ ~~A~~ ~~approved~~ water supply for fire protection, either temporary or permanent, shall be approved by the building official and fire code official and made available as soon as combustible material arrives on the site.

SECTION 3314 FIRE WATCH DURING CONSTRUCTION

SECTION 3322 MOTORIZED CONSTRUCTION EQUIPMENT

3322.1 Conditions of use. Internal-combustion-powered construction equipment shall be used in accordance with all of the following conditions:

1. Equipment shall be located so that exhausts do not discharge against combustible material.
2. Exhausts shall be piped to the outside of the building.
3. Equipment shall not be refueled while in operation.
4. Fuel for equipment shall be stored in an area outside of the building which is approved by the fire code official.

SECTION 3323 SAFEGUARDING ROOFING OPERATIONS

3323.1 General. Roofing operations utilizing heat-producing systems or other ignition sources shall be conducted in accordance with Sections 3323.2 and 3323.3 and Chapter 35 of the International Fire Code.

3323.2 Asphalt and tar kettles. Asphalt and tar kettles shall be operated in accordance with Section 303 of the International Fire Code.

3323.3 Fire extinguishers for roofing operations. Fire extinguishers shall comply with Section 906. There shall be not less than one multiple-purpose portable fire extinguisher with a minimum 3-A 40-B:C rating on the roof being covered or repaired.

CHAPTER 35 REFERENCED STANDARDS

NFPA

National Fire Protection Association
1 Batterymarch Park
Quincy MA 02169-7471

56--17:

Standard for Fire and Explosion Prevention during Cleaning and Purging of Flammable Gas Piping Systems

241--13:

Standard for Safeguarding Construction, Alteration, and Demolition Operations

Reason:

This change takes the current requirements of Chapter 33 of the IFC and incorporates them into Chapter 33 of the IBC. It makes no changes in technical requirements and retains all requirements of both codes. Explanations of each editorial change is given section by section at the end of this reason statement.

The purview of the fire code committee for sections currently under their purview (indicated by an “[F]” before the appropriate sections), and the authority of the fire code official where the fire code official’s approval is currently required, are preserved. The practice of having key fire safety provisions in the IBC that are maintained by the IFC committee and enforced by the fire code official is already established. Many provisions of Chapter 9 do this.

Requirements for fire safety are currently found in both the IBC and the IFC, with considerable overlap. For instance, requirements for fire extinguishers, means of egress, standpipes, sprinkler systems, and water supply are currently in both codes.

Most significant construction fires are the result of noncompliance with current code requirements. The consolidation of these chapters into the IBC will reduce the likelihood of code violations leading to fire, and will be beneficial for several other reasons. First, there are jurisdictions that do not adopt the IFC and the requirements will be more accessible to them. Second, enforcement activities for key provisions such as fire watches, a fire prevention program superintendent and plan, temporary heating equipment safety, cooking areas, rubbish and debris disposal, hot work precautions, roofing precautions, and access for firefighting—all which appear in the IFC but not the IBC—are less likely to be neglected. Third, problems in correlation of overlapping requirements will be eliminated.

Here is a section-by-section explanation of modifications:

Chapter 33 title: changed to reflect the inclusion of IFC fire safety provisions.

3301.1: General: the scope is expanded to include the current scope of the Chapter 33 of the IFC, including required compliance with NFPA 241 for items not specifically addressed.

3301.2: Purpose: the IBC currently has no Purpose section, this is brought over from the IFC and modified to make it clear that fire safety is one purpose among others.

3301.3 Storage and placement: renumbering only.

3302.3 Fire safety during construction: deleted since requiring compliance with Chapter 33 of the IFC is no longer necessary; all the fire safety provisions of Chapter 33 of the IFC are being added here.

3303.7 Fire safety during demolition: deleted since requiring compliance with Chapter 33 of the IFC is no longer necessary; all the fire safety provisions of Chapter 33 of the IFC are being added here.

3309 TEMPORARY HEATING EQUIPMENT: all subsections 3309.1 through 3309.6 are unchanged from parallel provisions in Section 3303 of the IFC, except to add references to the IFC where appropriate.

3310 PRECAUTIONS AGAINST FIRE: all subsections 3310.1 through 3310.8 are unchanged from parallel provisions in Section 3304 of the IFC, except to add reference to the IFC where appropriate and editorial modifications to preserve the authority of the fire code official in subsections 3310.1, 3310.3, 3310.5.2, and 3310.8.

3311 FLAMMABLE AND COMBUSTIBLE LIQUIDS: all subsections 3311.1 through 3311.6 are unchanged from parallel provisions in Section 3305 of the IFC, except to add references to the IFC where appropriate.

3312 FLAMMABLE GASES: all subsections 3312.1 through 3312.2.1 are unchanged from parallel provisions in Section 3306 of the IFC, except to add references to the IFC where appropriate.

3313 EXPLOSIVE MATERIALS: all subsections 3313.1 through 3313.3 are unchanged from parallel provisions in Section 3307 of the IFC, except to add references to the IFC where appropriate, and editorial modifications to preserve the authority of the fire code official in subsection 3313.3.

3314 OWNER'S RESPONSIBILITY FOR FIRE PROTECTION: all subsections 3314.1 through 3314.8 are unchanged from parallel provisions in Section 3308 of the IFC, except to add references to the IFC where appropriate, and editorial modifications to preserve the authority of the fire code official in subsection 3314.3.

3315 FIRE REPORTING: Subsection 3315.1 is unchanged from parallel provisions in Section 3309 of the IFC except to editorial modification to preserve the authority of the fire code official.

3316 ACCESS FOR FIRE FIGHTING: Subsections 3316.1 AND 3316.2 are unchanged from parallel provisions in Section 3310 of the IFC, except to add a reference to the IFC where appropriate in 3316.2 and an editorial modification to preserve the authority of the fire code official in subsection 3316.1.

3317 FIRE EXTINGUISHERS is current IBC Section 3309, which parallel the current provisions of IFC 3315 Portable Fire Extinguishers. The requirements were identical except for minor editorial wording such as "not less than" vs. "not fewer than," and "including, but not limited to" in one of the items. The wording of the IFC was used, and an editorial change was made to 3317.1 to retain the authority of the fire code official in addition to the building official for enforcement, since the same requirement was found in both codes.

(Current IBC subsection 3309.2 Fire hazards was deleted; it is no longer necessary since all fire safety provisions of Chapter 33 of the IFC are being added.)

3318 MEANS OF EGRESS is current IBC Section 3310, which parallels the current provisions of IFC 3311 Means of Egress.

3318.1 Stairways required: renumbered only.

3318.2 Maintenance of means of egress: the requirements of this subsection were essentially the same as IFC Section 3311.2, but the wording differed, especially for the exception. The word "required" in front of means of egress was brought over from the fire code, and the exception was modified to incorporate accessible means of egress, which appeared in the fire code. The revisions were made to incorporate the intent of both codes, which were thought to be the same. Editorial changes were made to retain the authority of the fire code official for approval since similar provisions for temporary means of egress were found in both codes.

3319 STANDPIPES is current IBC Section 3311, which parallel the current provisions of IFC 3313. Subsections 3319.1, 3319.2, and 3319.3 have been renumbered only.

3320 AUTOMATIC SPRINKLER SYSTEM is current IBC Section 3312, which parallel the current provisions of IFC 3314.

3320.1 Completion before occupancy: editorially modified to retain references to code sections in the IBC and IFC as they appear in their respective codes, and to retain the authority of both the building officials and fire code official from the respective codes.

3320.2 Operation of valves: renumbered only. "Shall be permitted" as used by the IBC was retained instead of "shall be allowed" per the IFC.

3321 WATER SUPPLY FOR FIRE PROTECTION is current IBC Section 3313, which parallel the current provisions of IFC 3312.

3321.1 Where required: editorial changes were made to make it clear that approvals are needed from both the building official and the fire code official, since approval is currently required by each code.

3314 FIRE WATCH DURING CONSTRUCTION was deleted since the identical requirement appears in proposed Section 3310.5.1, brought over from the IFC.

3322 MOTORIZED CONSTRUCTION EQUIPMENT is current section 3316 of the IFC.

3322.1 Conditions of use: an editorial change was made in item 4 to retain the authority of the fire code official.

3323 SAFEGUARDING ROOFING OPERATIONS is current section 3317 the IFC. Editorial changes were made to subsections 3323.1 and 3323.1 to make appropriate reference to the IFC for referenced code sections.

Here are the current IFC sections and their corresponding sections in this proposal:

IFC Section 3301: it remains in the IFC.

IFC Section 3302: deleted as unnecessary to follow IBC convention.

IFC 3303: proposed IBC 3309

IFC 3304: proposed IBC 3310

IFC 3305: proposed IBC 3311

IFC 3306: proposed IBC 3312

IFC 3307: proposed IBC 3313

IFC 3308: proposed IBC 3314

IFC 3309: proposed IBC 3315

IFC 3310: proposed IBC 3316

IFC 3311: proposed IBC 3318

IFC 3312: proposed IBC 3321

IFC 3313: proposed IBC 3319

IFC 3314: proposed IBC 3320

IFC 3315: proposed IBC 3317

IFC 3316: proposed IBC 3322

IFC 3317: proposed IBC 3323

Cost Impact

The code change proposal will not increase or decrease the cost of construction .

Currently the IBC requires that all the fire safety requirements of Chapter 33 of the IFC be enforced (IBC Section 3302.3). Therefore the moving of these provisions into the IBC will have no effect on the cost of construction.

Analysis: NFPA 56 and NFPA 241 are already referenced in the I-codes. Note that there has been erratum that changed the edition of NFPA 241 referenced in the 2018 IFC to the 2013 edition.

Internal ID: 3482

F263-18

IFC: 3308

Proponent: Jeffrey Shapiro, representing Self (jeff.shapiro@intlcodeconsultants.com)

2018 International Fire Code

Revise as follows:

SECTION 3308.3303 OWNER'S RESPONSIBILITY FOR RESPONSIBILITY FOR FIRE PROTECTION

~~3308.1~~**3303.1 Program development and maintenance.** The *owner* or *owner's* authorized agent shall be responsible for the development, implementation and maintenance of a written plan establishing a fire prevention program at the project site applicable throughout all phases of the construction, repair, *alteration* or demolition work. The plan shall address the requirements of this chapter and other applicable portions of this code, the duties of staff, and staff training requirements. The plan shall be made available for review by the *fire code official* upon request.

~~3308.2~~**3303.2 Program superintendent.** The *owner* shall designate a person to be the fire prevention program superintendent who shall be responsible for the fire prevention program and ensure that it is carried out through completion of the project. The fire prevention program superintendent shall have the authority to enforce the provisions of this chapter and other provisions as necessary to secure the intent of this chapter. Where guard service is provided in accordance with NFPA 241, the superintendent shall be responsible for the guard service.

Add new text as follows:

3303.3 Daily fire safety inspection. The fire prevention program superintendent shall be responsible for completion of a daily fire safety inspection at the project site. Each day, all building and outdoor areas shall be inspected to ensure compliance with the inspection list in this section. The results of each inspection shall be documented and maintained on site until a certificate of occupancy has been issued. Documentation shall be immediately available on site for presentation to the fire code official upon request. Failure to properly conduct, document and maintain documentation required by this section shall constitute an unlawful act in accordance with Section 110.1 and shall result in the issuance of a notice of violation in accordance with Section 110.3 to the fire prevention program superintendent. Upon the third offence in any 30-day period, a stop work order shall be issued in accordance with Section 112, and work shall not resume until satisfactory assurances of future compliance have been presented to and approved by the fire code official.

1. Any contractors entering the site to perform hot work each day have been instructed in hot work safety requirements in Chapter 35 and hot work is only performed in areas approved by the fire prevention superintendent.
2. Temporary heating equipment is maintained away from combustible materials in accordance with the equipment manufacturer's instructions.
3. Combustible debris, rubbish and waste material is removed from the building in areas where work is not being performed.
4. Temporary wiring does not have exposed conductors.
5. Flammable liquids and other hazardous materials are stored in locations that have been approved by the fire prevention superintendent when not involved in work that is being performed.
6. Fire apparatus access roads required by Section 3310 are maintained clear of obstructions that reduce the width of the usable roadway to less than 20 feet.
7. Fire hydrants are clearly visible from access roads and are not obstructed.
8. The location of fire department connections to standpipe and in-service sprinkler systems are clearly identifiable from the access road and such connections are not obstructed.
9. Standpipe systems are in service and continuous to the highest work floor, as specified in Section 3313.
10. Portable fire extinguishers are available in locations required by Section 3315 and 3317.3.

~~3308.3~~**3303.4 Prefire plans.** The fire prevention program superintendent shall develop and maintain an *approved* prefire plan in cooperation with the fire chief. The fire chief and the *fire code official* shall be notified of changes affecting the utilization of information contained in such prefire plans.

3308.43303.5 Training. Training of responsible personnel in the use of fire protection equipment shall be the responsibility of the fire prevention program superintendent. Records of training shall be kept and made a part of the written plan for the fire prevention program.

3308.53303.6 Fire protection devices. The fire prevention program superintendent shall determine that all fire protection equipment is maintained and serviced in accordance with this code. The quantity and type of fire protection equipment shall be *approved*. Fire protection equipment shall be inspected in accordance with the fire protection program.

3308.63303.7 Hot work operations. The fire prevention program superintendent shall be responsible for supervising the permit system for hot work operations in accordance with Chapter 35.

3308.73303.8 Impairment of fire protection systems. Impairments to any *fire protection system* shall be in accordance with Section 901.

3308.7.13303.8.1 Smoke detectors and smoke alarms. Smoke detectors and smoke alarms located in an area where airborne construction dust is expected shall be covered to prevent exposure to dust or shall be temporarily removed. Smoke detectors and alarms that were removed shall be replaced upon conclusion of dust-producing work. Smoke detectors and smoke alarms that were covered shall be inspected and cleaned, as necessary, upon conclusion of dust-producing work.

3308.83303.9 Temporary covering of fire protection devices. Coverings placed on or over fire protection devices to protect them from damage during construction processes shall be immediately removed upon the completion of the construction processes in the room or area in which the devices are installed.

Reason:

The number and magnitude of construction fires in the past few years has been well documented in NFPA loss reports and on national news. Many of these fires are not "accidental," but are instead the result of inexcusable carelessness...failing to follow basic fire safety practices. For some reason, it seems that there has been a loss of attention to fire safety at construction sites. Although major construction fires represent a relatively small percentage of the overall population of buildings under construction at any given time, the consequences of these fires is seeming to impact nearby buildings and neighborhoods with increasing frequency and increasing levels of damage.

Contractors are busy trying to stay on schedule. Fire inspectors show up to look at specific inspection tasks, such as sprinkler inspections, without having time to look at construction fire safety concerns. Building inspectors are on tight inspection schedules and may not have time or be trained to look for fire safety concerns. It seems that nobody is focused on construction site fire safety. Ultimately, this responsibility falls on the owner and the fire prevention program superintendent to ensure compliance, and there needs to be a viable way to verify that the responsible parties are doing their code-required jobs.

Hence, this proposal is intended to serve as a hammer to make sure that there is a motivation to pay attention to basic fire safety requirements and to pin this responsibility on the owner and the fire prevention program superintendent. By requiring daily inspections and documentation, any fire or building inspector can simply request to see the checklist when at the site for any reason, and a clear enforcement path is specified when non-compliance is encountered. While it's true that someone could just do the paperwork exercise, the liability associated with fraudulently documenting compliance in the event of an incident would be significant, and presumably, there will be cases where code officials will spot check compliance.

Unfortunately, there is no perfect solution to this issue. But this proposal represents a significant step forward with regard to getting responsible parties to pay attention to a significant and ongoing issue.

This proposal also recommends relocating Section 3308 to Section 3303. This is perhaps the most important part of Chapter 33, and the requirements need to be right up front.

Cost Impact

The code change proposal will increase the cost of construction .

The additional time required for personnel to complete the tasks required by this section will increase the cost of construction.

Internal ID: 2280

F264-18

IFC: 3304.5, 3304.5.1, 3304.5.2, 3304.5.2.1 (New), 3304.5.2.2 (New), 3304.5.2.3 (New), 3304.5.3, 3308.5.4 (New), 3304.8, 3308.1, 3308.1.1 (New), 3308.2, 3308.3, 3308.4, 3308.5, , 3308.6, 3308.7, 3308.8, 501.3, 501.3.1 (New), 202 (New)

Proponent: Michael O'Brian, Chair, representing FCAC (fcac@iccsafe.org)

2018 International Fire Code

Revise as follows:

3304.5 Fire watch. Where required by the *fire code official* or the ~~pre-fire site safety plan~~ established in accordance with Section ~~3308.3~~3308.1, a fire watch shall be provided for building demolition and for building construction that is hazardous in nature, such as temporary heating or hot work construction.

3304.5.1 Fire watch during construction. Where required by the *fire code official*, ~~a~~ fire watch shall be provided during nonworking hours for new construction that exceeds 40 feet (12 192 mm) in height above the lowest adjacent grade at any point along the building perimeter, any new multi-story construction with an aggregate area exceeding 50,000 sq. ft. per story or as required by the fire code official.

3304.5.2 Fire watch personnel. Trained personnel shall be provided to serve as an on-site fire watch. Fire watch personnel shall be provided ~~with not fewer than one approved means for notification of the fire department, and the sole duty of such personnel shall be to perform constant patrols and watch for the occurrence of fire. The combination of fire watch duties and site security duties is acceptable. Fire watch personnel shall be trained in the use of portable fire extinguishers in accordance with this section.~~

Add new text as follows:

3304.5.2.1 Duties. The primary duty of fire watch personnel shall be to perform constant patrols and watch for the occurrence of fire. The combination of fire watch duties and site security duties is acceptable.

3304.5.2.2 Training. Personnel shall be trained in to serve as an on-site fire watch. Training shall include the use of portable fire extinguishers. Fire extinguishers and fire reporting shall be in accordance with Section 3309.

3304.5.2.3 Means of notification. Fire watch personnel shall be provided with not fewer than one approved means for notifying the fire department.

Revise as follows:

3304.5.3 Fire watch location and records. The fire watch shall include areas specified by the ~~pre-fire site safety plan~~ established in accordance with Section ~~3308.3~~. ~~The fire watch personnel shall keep a record of all time periods of duty, including a log entry each time the site was patrolled and each time a structure under construction was entered and inspected. The records and log entries shall be made available for review by the fire code official upon request.~~3308.

3308.5.4 Fire Watch Records. Fire watch personnel shall keep a record of all time periods of duty, including the log entry each time the site was patrolled, and each time a structure was entered and inspected. Records shall be made available for review by the fire code official upon request.

3304.8 Cooking. Cooking shall be prohibited except in *approved* designated cooking areas separated from combustibile materials by a minimum of ten feet. Signs with a minimum letter height of 3 inches (76 mm) and a minimum brush stroke of 1/2 inch (13 mm) shall be posted in conspicuous locations in designated cooking areas and state:
DESIGNATED COOKING AREA

COOKING OUTSIDE OF A DESIGNATED COOKING AREA IS PROHIBITED

3308.1 Program development and maintenance. The owner or owner's authorized agent shall be responsible for the development, implementation and maintenance of ~~a~~an approved written site safety plan establishing a fire prevention program at the project site applicable throughout all phases of the construction, repair, alteration or demolition work. The plan shall address the requirements of this chapter and other applicable portions of this code, the duties of staff, and staff training requirements. The plan shall be submitted and approved before a building permit is issued. Any changes to the plan shall be made available for review by the fire code official upon request.~~submitted for approval.~~

Add new text as follows:

3308.1.1 Components of Site Safety Plans. Site Safety Plans shall include the following as applicable:

1. Name and contact information of Site Safety Director
2. Documentation of the training of the Site Safety Director and fire watch personnel
3. Procedures for reporting emergencies
4. Fire Department Vehicle Access routes
5. Location of fire protection equipment including portable fire extinguishers, standpipes, fire department connections and fire hydrants.
6. Smoking and cooking policy, designated areas to be used when approved, and signage locations in accordance with 3304.8.
7. Location and safety considerations for temporary heating equipment
8. Hot work permit plan
9. Plans for control of combustible waste material
10. Locations and methods for storage and use of flammable and combustible liquids and other hazardous materials
11. Provisions for site security
12. Changes that affect this plan
13. Other site-specific information required by the Fire Code Official

Revise as follows:

3308.2 ~~Program superintendent.~~Site Safety Director. ~~The owner shall designate a person to be the fire prevention program superintendent who~~ site safety director. ~~The site safety director shall be responsible for the fire prevention program and ensure that it is carried out through completion of the project. The fire prevention program superintendent ensuring compliance with the site safety plan. The site safety director shall have the authority to enforce the provisions of this chapter and other provisions as necessary to secure the intent of this chapter. Where guard service is provided in accordance with NFPA 241, the superintendent~~ site safety director shall be responsible for the guard service.

3308.3 ~~Prefire plans.~~Qualifications. ~~The fire prevention program superintendent shall develop and maintain an approved prefire plan in cooperation with the fire chief. The fire chief and the fire code official shall be notified of changes affecting the utilization of information contained in such prefire plans.~~ Site Safety Director shall acquire training specific to their roles and responsibilities. Upon request, the training and qualifications of the Site Safety Director shall be submitted to the Fire Code Official for approval.

3308.4 Training. ~~Training of fire watch and other responsible personnel in the use of fire protection equipment shall be the responsibility of the fire prevention program superintendent.~~ site safety director. ~~Records of training shall be kept and made a part of the written plan for the fire prevention program.~~ site safety plan.

3308.5 Fire protection devices. ~~The fire prevention program superintendent shall determine~~ Site Safety Director shall ensure that all fire protection equipment is maintained and serviced in accordance with this code. The quantity and type of fire protection equipment shall be approved. Fire protection equipment shall be inspected in accordance with the fire protection program.

3308.5 Fire protection devices. ~~The fire prevention program superintendent shall determine that all fire protection equipment is maintained and serviced in accordance with this code. The quantity and type of fire protection equipment shall be approved. Fire protection equipment shall be inspected in accordance with the fire protection program.~~

3308.6 Hot work operations. ~~The fire prevention program superintendent shall be responsible for supervising the permit system for~~ Site Safety Director shall ensure hot work operations and permit procedures are in accordance with Chapter 35.

3308.7 Impairment of fire protection systems. ~~Impairments~~ The Site Safety Director shall ensure impairments to any fire protection system shall be are in accordance with Section 901.

3308.8 Temporary covering of fire protection devices. Coverings placed on or over fire protection devices to protect them from damage during construction processes shall be immediately removed upon the completion of the construction processes in the room or area in which the devices are installed.

501.3 Construction documents. *Construction documents* for proposed fire apparatus access, location of *fire lanes*, security gates across fire apparatus access roads and *construction documents* and hydraulic calculations for fire hydrant systems shall be submitted to the fire department for review and approval prior to construction.

Add new text as follows:

501.3.1 Site Safety Plan. The owner or owner's authorized agent shall be responsible for the development, implementation and maintenance of an approved written site safety plan in accordance with Section 3308.

SITE SAFETY PLAN

A plan developed to establish a fire prevention program at a construction site.

Reason:

Fires in buildings under construction have, unfortunately, become routine. Fire departments across the United States are being stressed beyond their limits by these fires, and communities are being subjected to all of the negative consequences of losing major projects and draining fire protection resources. Virtually every national organization with a stake in this issue are wrestling with solutions. Part of the solution is to provide on-site safety supervision throughout the construction project. This code change will refine and clarify current requirements, and will require that the site safety plans be submitted with other construction documents in order to inform the building officials of their existence and their requirements. Specifically:

3304.5 This section has been reformatted for clarity.

3304.5.1 Makes a fire watch mandatory for buildings above 40 ft. in height or multi-story construction with an aggregate area exceeding 50,000 sq. ft. These buildings are large enough to create a significant loss to a community, endanger firefighters, and consume resources at an extraordinary rate if the building burns.

3304.5.2.1 maintains the requirement that the primary role of fire watch personnel is to watch for fires, but may also serve as security.

3305.2.2 Maintains current requirements for training fire watch personnel

3304.5.2.3 Requires the fire watch person to have a means to notify the fire department.

3304.8 introduces a requirement for separating the construction site from cooking operations.

3308.1 introduces a new requirement for the site safety plan to be submitted for approval before a building permit is issued. This is intended to highlight the importance of having a plan, and getting it into the hands of the inspectors before the building is actually under construction.

3308.1.1 outlines the content required for a site safety plan.

3308.2 simply changes the nomenclature from "fire prevention program superintendent" to "site safety director".

3308.3 requires the site safety director to be trained in the duties of the job

3308.4 updates the verbiage of the existing requirements

3308.5 updates the language and removes an ambivalent requirement for the "quantity and type of fire protection equipment" to be approved; it also removes language about inspecting the equipment because that is deemed to be redundant language

3308.6 inserts a reference to Chapter 35 for hot work and updates the language.

Section 501.3.1 is updated to require a site safety plan and place responsibility on the owner.

Finally, a definition for site safety plan is added.

This proposal is submitted by the ICC Fire Code Action Committee (FCAC). The FCAC was established by the ICC Board of Directors to pursue opportunities to improve and enhance assigned International Codes with regard to fire safety and hazardous materials in new and existing buildings and facilities and the protection of life and property in wildland urban interface areas. In 2017 the Fire-CAC has held 3 open meetings. In addition, there were numerous conference calls, Regional Work Group and Task Group meetings for the current code development cycle, which included members of the committees as well as any interested parties, to discuss and debate the proposed changes. Related documentation and reports are posted on the FCAC website at: <https://www.iccsafe.org/codes-tech-support/cs/fire-code-action-committee-fcac/>

Cost Impact

The code change proposal will increase the cost of construction .

it's likely that this code change will have a minimal, but increased cost impact. Many construction sites already comply with these provisions; for those that don't, the cost of added security and development of a site safety plan will be additional costs.

Internal ID: 390

F265-18

IFC: 3304.9 (New)

Proponent: Adria Reinertson, representing Riverside County Fire Department, California Fire Chiefs Association (adriar@moval.org)

2018 International Fire Code

Add new text as follows:

3304.9 Separations between construction areas. Separations used in Type I and Type II construction to separate construction areas from occupied portions of the building, shall be constructed of materials that comply with one of the following:

1. Non-combustible materials
2. Materials that exhibit a flame spread index not exceeding 25 when tested in accordance with ASTM E84 or UL 723
3. Materials exhibiting a heat peak release rate not exceeding 300kW/m² when tested in accordance with ASTM E1354 at an incident heat flux of 50 kW/m² in the horizontal orientation on specimens at the thickness intended for use.

Reason:

These tarpaulins are found frequently in construction zones and need to exhibit some improved fire performance, because they could propagate fire more easily otherwise. The options provided are such that many materials exist that can comply with at least one of the requirements.

Cost Impact

The code change proposal will increase the cost of construction .

Fire retarded tarpaulins can be roughly twice the cost of non-fire-retarded tarpaulins and therefore will increase the cost of separating the areas, but they will increase fire safety.

Internal ID: 608

F266-18

IFC: 3308.4 (New)

Proponent: Stephen DiGiovanni, representing ICC Ad Hoc Committee on Tall Wood Buildings (TWB) (TWB@iccsafe.org)

2018 International Fire Code

3308.4 Fire safety requirements for buildings of Types IV-A, IV-B, and IV-C construction. Buildings of Types IV-A, IV-B, and IV-C construction designed to be greater than six stories above grade plane shall comply with the following requirements during construction unless otherwise approved by the fire code official.

1. Standpipes shall be provided in accordance with Section 3313.
2. A water supply for fire department operations, as approved by the fire chief.
3. Where building construction exceeds six stories above grade plane, at least one layer of noncombustible protection where required by Section 602.4 of the International Building Code shall be installed on all building elements more than 4 floor levels, including mezzanines, below active mass timber construction before erecting additional floor levels.
4. Where building construction exceeds six stories above grade plane required exterior wall coverings shall be installed on all floor levels more than 4 floor levels, including mezzanines, below active mass timber construction before erecting additional floor level.

Exception: Shafts and vertical exit enclosures.

Reason:

The Ad Hoc Committee on Tall Wood Buildings (TWB) was created by the ICC Board to explore the science of tall wood buildings and take action on developing code changes for tall wood buildings. The TWB has created several code change proposals with respect to the concept of tall buildings of mass timber and the background information is at the end of this Statement. Within the statement are important links to information, including documents and videos, used in the deliberations which resulted in these proposals.

The TWB has developed a number of proposals to potentially increase the permitted height and area for Type IV structures, specifically mass timber buildings adding additional Types IV-A, IV-B & IV-C. One of the basic requirements incorporated into these proposed increased heights and areas is the added active and passive protection features to these structures.

The goal of this proposal is to provide guidance and requirements for when this combustible building is most vulnerable, while under construction prior to fire protection systems have been installed.

Over the recent years we have experienced a number of fires while combustible buildings have been under construction. It is understood the vast majority of these fires did occur in structures of light-frame structural wood members which present a significant fire hazard when exposed. Even with this fact we cannot simply ignore the potential risk of fire in combustible construction simply due to the size of the timber element and the potentially longer period of time for ignition as the potentially fuel load of a mass timber building can be substantial.

The TWB had a great deal of discussion regarding the proposed requirements regarding water supply to the buildings of combustible construction sites. On one hand, there was a desire to establish a minimum water flow of 250 gpm with a minimum pressure. But the counter discussion identified that these combustible building construction sites may have various degrees of hazards on the site and was not restrictive to just the structure. Mass timber construction typically proceeds with little stored combustible material on the site, mass timber is generally installed as it arrives. Thus, there may be more or fewer site hazards than on a typical construction site utilizing combustible materials. Moreover, protection of the installed material must occur before the project moves above certain specified numbers of levels. This is very different from conventional construction processes.

With this understanding, the TWB is proposing project developers meet and confer with the local fire service to establish the fire department's response needs, in terms of water flow and pressure, for the specific building, while under construction, and job site.

While sub-sections 1 and 2 apply to the delivery of water to the job site, and/or structure, sub-sections 3 and 4 are specific to the passive protection related to the structure. Due to the proposed increased heights and areas, the TWB felt it was important to require interior and exterior passive protection as the construction progressed. This would insure the lower portions of the combustible structure had redundant, active and passive, protection as greater heights were added.

Two figures are shown below to illustrate the requirements of sub-sections 3 and 4 of this proposal. Since both buildings will exceed six-stories, protection must be provided during construction. The solid thick lines indicate building

elements that are required to be protected. Solid thin lines indicate elements that are in-place, but are not required to be protected and dashed lines indicate elements that have not yet been placed. Figure 1 is shown to illustrate when protection is first required on a building under construction. When level 6 is the active level of mass timber construction, protection of the building elements and the exterior wall coverings are required before level 7 panels can be placed. In Figure 2, the progress of protection on each successive level is indicated as construction continues. In this example, level 14 is the active level of mass timber construction, so prior to placement of floor panels at level 15, protection is required on level 9.

New paragraph for the reason statement: Two figures are shown below to illustrate the requirements of sub-sections 3 and 4 of this proposal. Since both buildings will exceed six-stories, protection must be provided during construction. The solid thick lines indicate building elements that are required to be protected. Solid lines indicate elements that are in-place, but are not required to be protected and dashed lines indicate elements that have not yet been placed. Figure 1 is shown to indicate when protection is first required to be provided on a building under construction. When level 6 is the active level, protection of the building elements and the exterior wall coverings are required before level 7 panels can be placed. In Figure 2, the progress of protection on each successive level is indicated as construction continues. In this example, level 14 is the active level, so prior to placement of floor panels at level 15, protection is required on level 9.

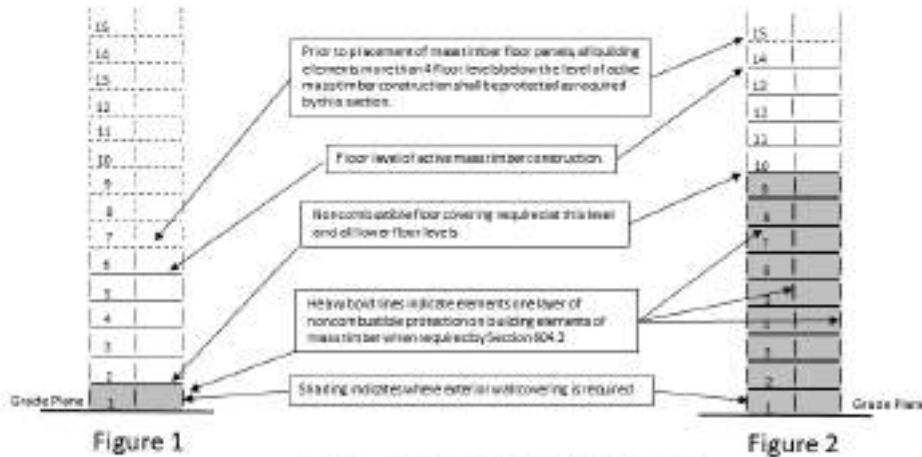

Examples of Protection During Construction For Mass Timber Buildings Greater Than 6 Stories Above Grade Plane

The TWB strongly feels these code change proposals should be adopted as a whole package. By adopting a few of the code change proposals without the complete package potentially ignores the details required to insure these proposed projects are designed, built and maintained properly now and in the future. **Background information:** The ICC Board approved the establishment of an ad hoc committee for tall wood buildings in December of 2015. The purpose of the ad hoc committee is to explore the science of tall wood buildings and to investigate the feasibility and take action on developing code changes for tall wood buildings. The committee is comprised of a balance of stakeholders with additional opportunities for interested parties to participate in the four Work Groups established by the ad hoc committee, namely: Code; Fire; Standards/Definitions; and Structural. For more information, be sure to visit the ICC website <https://www.iccsafe.org/codes-tech-support/cs/icc-ad-hoc-committee-on-tall-wood-buildings/> (link active and up to date as of 12/27/17). As seen in the “Meeting Minutes and Documents” and “Resource Documents” sections of the committee web page, the ad hoc committee reviewed a substantial amount of information in order to provide technical justification for code proposals.

The ad hoc committee developed proposals for the followings code sections. The committee believes this package of code changes will result in regulations that adequately address the fire and life safety issues of tall mass timber buildings.

IBC Code Section	Description
403.3.2	Water supply requirements for fire pumps in high rise buildings of Type IVA and IVB construction.
504.3	Allowable building height (feet) for buildings of Type IVA, IVB and IVC construction. No changes to Type IV HT construction.
504.4	Allowable building height (stories) for buildings of Type IVA, IVB and IVC construction. No changes to Type IV HT.
506.2	Allowable building area for buildings of Type IVA, IVB and IVC construction. No changes to Type IV HT.
508.4.4.1 509.4.1.1 (new)	Requirements for mass timber building elements serving as fire barriers or horizontal assemblies in buildings of Type IVB or IVC construction.
602.4	Type of Construction requirements for new proposed types of construction: Types IVA, IVB and IVC. No changes to Type IV HT construction. Includes definitions for new terms: Mass timber and Noncombustible protection (mass timber). THIS IS THE KEY CODE CHANGE PROPOSAL WHICH OUTLINES THE CONSTRUCTION REQUIREMENTS FOR THE PROPOSED NEW TYPE OF MASS TIMBER BUILDINGS. THE PROPOSAL ALSO ADDRESSES CONCEALED SPACES, ADHESIVE PERFORMANCE AND EXTERIOR WALL PROTECTION.
703.8 (new)	The performance method to determine the increase to the fire resistance rating provided by noncombustible protection applied to the mass timber building element.
703.9 (new)	Requirements for sealants and adhesives to be placed at abutting edges and intersections of mass timber building elements. The reason statement references a Group B proposal to Chapter 17 for special inspection requirements of sealants and adhesives.
718.2.1	Requirements on the use of mass timber building elements used for Fireblocking.
722.7 (new)	Requirements for the fire resistance rating of mass timber elements, including minimum required protection and gypsum board attachment requirements.
3102	Requirements for membrane structures using Type IV HT construction.
3314.7 (new)	New special precautions during construction of buildings of Types IVA, IVB and IVC construction: Standpipes; Water supply for fire department connections; Noncombustible protection required for mass timber elements as construction height increases.
Appendix	Requirements for walls, floors and roofs of Type IV HT construction in buildings located in Fire Districts.
IFC Code Section	Description
701.6	Requirements which stipulate the owner's responsibility to maintain inventory of all required fire resistance rated construction in buildings of Types IVA and IVB construction. This includes an annual inspection and proper repair where necessary.
Proposed changes to be submitted in 2019 Group B	
IBC Chapter 17	Required special inspections of mass timber construction <ul style="list-style-type: none"> • Structural • Sealants and adhesives (see IBC 703.8)
IBC Chapter 23	An update to referenced standard APA PRG 320 Standard for Performance –rated Cross-laminated Timber which is currently undergoing revision to ensure the adequacy of the adhesives under fire conditions.

In addition, fire tests designed to simulate the three new construction types (Types IVA, IVB and IVC) in the ad hoc committee proposals were conducted at the Alcohol Tobacco and Firearms test lab facility. The TWB was involved in the design of the tests, and many members witnessed the test in person or online. The results of the series of 5 fire tests provide additional support for these proposals, and validate the fire performance for each of the types of construction proposed by the committee. The fire tests consisted of one-bedroom apartments on two levels, with both apartments having a corridor leading to a stair. The purpose of the tests was to address the contribution of mass timber to a fire, the performance of connections, the performance of through-penetration fire stops, and to evaluate conditions for responding fire personnel.

To review a summary of the fire tests, please visit:

<http://bit.ly/ATF-firetestreport>

To watch summary videos of the fire tests, which are accelerated to run in 3 ½ minutes, please visit:

<http://bit.ly/ATF-firetestvideos>

Both of these links were confirmed active on 12/27/17.

Cost Impact

The code change proposal will not increase or decrease the cost of construction .

This section provides information that was not previously set forth in the code, and does not change the requirements of current code, thus there is no cost impact when compared with present requirements.

Internal ID: 963

F267-18 Part I

IFC: SECTION 3318 (New), 3318.1 (New), 3318.1.1 (New), 3318.1.2 (New), 80

Proponent: Stephen Skalko, Stephen V. Skalko, P.E. & Associates, LLC, representing Masonry Alliance for Codes and Standards (svskalko@svskalko-pe.com); William Hall, Portland Cement Association, representing Alliance For Concrete Codes and Standards (jhall@cement.org)

THIS IS A 2 PART CODE CHANGE PROPOSAL. PART I WILL BE HEARD THE IFC COMMITTEE, PART II WILL BE HEARD BY THE IBC-G COMMITTEE. PLEASE SEE THE TENTATIVE HEARING ORDERS FOR THE RESPECTIVE COMMITTEES.

2018 International Fire Code

Add new text as follows:

SECTION 3318 PROTECTION OF COMBUSTIBLE CONSTRUCTION

3318.1 Fire safety requirements for buildings of Type III and V construction. Buildings of Types III and V construction designed to be four or more stories above grade plane shall meet the following requirements during construction unless otherwise approved by the fire official.

3318.1.1 Exposed interior combustible framing. Where portions of the building construction exceeds 40-feet in height above fire department vehicle access, exposed interior combustible framing members shall be protected during the construction process by a thermal barrier of 1/2-inch gypsum wallboard or a material that is tested in accordance with and meets the acceptance criteria of both the Temperature Transmission Fire Test and the Integrity Fire Test of NFPA 275 in accordance with Section 2603.4 of the International Building Code. Concealed spaces shall comply with Section 718 of the International Building Code.

The thermal barrier shall be installed on all exposed interior surfaces of combustible framing members below the 40-feet of height, including mezzanines, so that no more than two floors of combustible framing members for the building are exposed before erecting an additional floor level. When the building construction commences above the 40-feet of height, the thermal barrier shall be installed on all exposed interior combustible framing members, including mezzanines, so that a total of no more than one floor of combustible framing members for the building is exposed on the interior before erecting an additional floor level.

3318.1.2 Exposed exterior combustible framing. Where portions of the building construction exceeds 40-feet above fire department vehicle access, including mezzanines, exposed exterior combustible framing members below the 40-feet of height, shall be covered by a noncombustible material or exterior wall covering in accordance with Section 1404 of the International Building Code so that no more than two floors of exterior combustible framing are exposed before erecting additional floor levels. The noncombustible material or exterior wall covering shall continue to be installed on all exposed exterior combustible framing above the 40-feet of height, including mezzanines, so that a total of no more than one floor of combustible framing members are exposed on the exterior before erecting additional floor levels.

Add new standard(s) follows:

NFPA

National Fire Protection Association
1 Batterymarch Park
Quincy MA 02169-7471

275—17:

Standard Method of Fire Tests for the Evaluation of Thermal Barriers

Analysis: A review of the standard proposed for inclusion in the code, NFPA 275-17, with regard to the ICC criteria for referenced standards (Section 3.6 of CP#28) will be posted on the ICC website on or before April 2, 2018.

Analysis: The referenced standard, NFPA 275-17, is currently referenced in other 2018 I-codes.

Internal ID: 2057

F267-18 Part II

IBC: SECTION 3314 (New), 3314.1 (New), 3314.1.1 (New), 3314.1.2 (New)

Proponent: Stephen Skalko, Stephen V. Skalko, P.E. & Associates, LLC, representing Masonry Alliance for Codes and Standards (svskalko@svskalko-pe.com); William Hall, Portland Cement Association, representing Alliance For Concrete Codes and Standards (jhall@cement.org)

2018 International Building Code

Add new text as follows:

SECTION 3314 PROTECTION OF COMBUSTIBLE CONSTRUCTION

3314.1 Fire safety requirements for buildings of Type III and V construction. Buildings of Types III and V construction designed to be four or more stories above grade plane shall meet the following requirements during construction unless otherwise approved by the fire official.

3314.1.1 Exposed interior combustible framing. Where portions of the building construction exceeds 40-feet in height above fire department vehicle access, exposed interior combustible framing members shall be protected during the construction process by a thermal barrier of 1/2-inch gypsum wallboard or a material that is tested in accordance with and meets the acceptance criteria of both the Temperature Transmission Fire Test and the Integrity Fire Test of NFPA 275 in accordance with Section 2603.4. Concealed spaces shall comply with Section 718. The thermal barrier shall be installed on all exposed interior surfaces of combustible framing members below the 40-feet of height, including mezzanines, so that no more than two floors of combustible framing members for the building are exposed before erecting an additional floor level. When the building construction commences above the 40-feet of height, the thermal barrier shall be installed on all exposed interior combustible framing members, including mezzanines, so that a total of no more than one floor of combustible framing members for the building is exposed on the interior before erecting an additional floor level.

3314.1.2 Exposed exterior combustible framing. Where portions of the building construction exceeds 40-feet above fire department vehicle access, including mezzanines, exposed exterior combustible framing members below the 40-feet of height, shall be covered by a noncombustible material or exterior wall covering in accordance with Section 1404 so that no more than two floors of exterior combustible framing are exposed before erecting additional floor levels. The noncombustible material or exterior wall covering shall continue to be installed on all exposed exterior combustible framing above the 40-feet of height, including mezzanines, so that a total of no more than one floor of combustible framing members are exposed on the exterior before erecting additional floor levels.

Reason:

As light wood frame buildings of Type III and V construction continue to be built to large heights and areas as allowed in Tables 504.3, 504.4 and 506.2 of the code, there has been a notable increase in fires, especially for Group R2 Residential Occupancies constructed of combustible framing, while the building is under construction. This has resulted in significant loss of property for the building under construction and nearby properties exposed to the fire in part because important fire safety features such as passive fire protection for the combustible framing is not complete and automatic sprinkler system upon which these larger and taller buildings depend are not operational.

Besides the damage to the building under construction and to nearby properties some of these fires have required major street closures including interstates, and tied up firefighting resources to the extent that other areas of the communities were left under-protected for extended periods. An example is the major fire in Los Angeles with five stories of wood framing over a two-story concrete podium on December 8, 2014 that not only resulted in millions of dollars in damage to the building under construction, but also damaged adjacent buildings. The apartment building known as the DaVinci was a complete loss after the fire that was fueled by the five stories of wood frame construction. More than 250 firefighters were dispatched to the scene. The burning of the structure's wooden frame forced the closure of northbound Harbor Freeway (Hwy 110) and affected local streets causing major traffic disruptions for commuters and to the nearby business and residences. Buildings nearby were damaged by exposure to fire from the radiant heat as well as damage inside because the fire activated sprinklers in these adjacent buildings. It has been reported that the heat also melted or damaged computers and partition cubicles in neighboring buildings as well. The glazing in hundreds of windows of a nearby building was also damaged.

There are numerous examples of other large combustible framed apartment and condominium building that experienced significant fires and damage while the building was under construction that illustrate the fire risk these large buildings pose. The following is a list of six such incidences in 2017. This list is not necessarily inclusive of all similar large combustible building fires in 2017 while under construction.

1. Metropolitan Apartments, Raleigh NC March 17, 2017- 5-story apartments on concrete podium.
2. The Royale at City Place, Overland Park, KS March 20, 2017 - 5-story apartments
3. Fuse 47, College Park, MD April 24, 2017 - 5-story apartments on concrete podium.
4. Treadmark, Boston MA, June 28, 2017 - 6-story condominiums
5. Kelowna, BC, Canada July 8, 2017 - 6-story apartments on concrete podium
6. Edison on the Charles, Waltham, MA July 23, 2017 - 5-story apartments

The goal of this proposal is to provide guidance and requirements for protection when this combustible building is most vulnerable, while under construction and prior to passive and active fire protection being installed. Recently the ICC Tall Wood Building Ad Hoc Committee discussed similar fire protection measures for Mass Timber Buildings under construction. The TWB Committee recognized the risks associated with taller buildings of combustible construction and the hazards they pose for fire department exterior and interior attack tactics

To reduce the risk of these construction fires this proposal will require the exposed combustible framing members be covered with a thermal barrier on the inside of the building and the planned exterior wall covering on the outside. The thermal barrier protection is similar to the requirements for exposed foam plastic insulation (a combustible material) in 2603.4. If combustible framing should be ignited during construction both the thermal barrier and the exterior wall coverings reduce exposure of other combustible materials from the fire incident.

The passive protection should be provided when the construction reaches the 40-foot height above the fire department vehicle access. The 40-foot threshold is consistent with the threshold when standpipes for construction are required by 3311.1. These levels of fire protection are consistent with the fire risks associated with these larger buildings of combustible construction, and upon which the building code provisions are based. Also, like the standpipe requirements, the passive protection must be extended as each floor is added.

Cost Impact

The code change proposal will increase the cost of construction .

This proposal is expected to increase the cost of construction due to the passive fire protection having to be completed on lower floors before construction can begin higher up in the building. This increased cost however is necessary to reduce the risk of damage to adjacent properties due to fire exposure which results in economic hardship for repairs and disruption to businesses and residences, to minimize the impact to the public from traffic disruptions due to the size of the conflagrations, and to reduce the demand for fire service response due to these larger taller combustible framed buildings while under construction.

Internal ID: 3512

F268-18

IFC: 3312.1, 3312.2 (New), 3312.3 (New), 3312.3.1 (New), 3312.3.2 (New), 3312.3.3 (New), 3312.4 (New), 3312.5 (New);

IBC: [F] 3313.1, 3313.2 (New), 3313.3 (New), 3313.3.1 (New), 3313.3.2 (New), 3313.3.3 (New), 3313.4 (New), 3313.5 (New);

IEBC: [F]1509.1, 1509.2 (New), 1509.3 (New), 1509.3.1 (New), 1509.3.2 (New), 1509.3.3 (New), 1509.4 (New), 1509.5 (New)

Proponent: Stephen DiGiovanni, representing self (sdigiovanni@clarkcountynv.gov)

2018 International Fire Code

CHAPTER 33 FIRE SAFETY DURING CONSTRUCTION AND DEMOLITION

SECTION 3312 WATER SUPPLY FOR FIRE PROTECTION

Revise as follows:

3312.1 When required. An approved water supply for fire protection, either temporary or permanent, shall be made available as soon as combustible material-structural elements arrives on the site-site, upon commencement of vertical combustible construction, and upon installation of a standpipe system in buildings under construction, in accordance with Sections 3312.2 through 3312.5.

Exception: The fire code official is authorized to reduce the fire-flow requirements for isolated buildings or a group of buildings in rural areas or small communities where the development of full fire-flow requirements is impractical.

Add new text as follows:

3312.2 Combustible structural elements. When combustible structural elements of the building under construction are delivered to a site, a minimum fire flow of 1,000 gpm shall be provided. The fire hydrant used to provide this fire flow supply shall be within 500 feet of the combustible structural elements, as measured along an approved fire apparatus access lane. Where the site configuration is such that one fire hydrant can not be located within 500 feet of all combustible structural elements, additional fire hydrants shall be required to provide coverage in accordance with this section.

3312.3 Vertical construction of Types III, IV, and V construction. Prior to commencement of vertical construction of Type III, IV, or V buildings that utilize any combustible structural elements, the fire flow required by Sections 3312.3.1 through 3312.3.3 shall be provided, accompanied by fire hydrants in sufficient quantity to deliver the required fire flow and proper coverage.

3312.3.1 Fire separation up to 30 feet. Where a building of Type III, IV, or V construction has a fire separation distance of less than 30 feet from property lot lines, and an adjacent property has an existing structure or otherwise can be constructed upon, the water supply shall provide either a minimum of 1,000 gpm, or the entire fire flow required for the building when constructed, whichever is greater.

3312.3.2 Fire separation of 30 feet up to 60 feet. Where a building of Type III, IV, or V construction has a fire separation distance of 30 feet up to 60 feet from property lot lines, and an adjacent property has an existing structure or otherwise can be constructed upon, the water supply shall provide a minimum of 1,000 gpm, or 50% of the fire flow required for the building when constructed, whichever is greater.

3312.3.3 Fire separation of 60 feet or greater. Where a building of Type III, IV, or V construction has a fire separation of 60 feet or greater from a property lot line, a water supply of 1,000 gpm shall be provided.

3312.4 Vertical Construction, Type I and II construction. If combustible construction materials are delivered to the construction site, water supply in accordance with Section 3312.2 shall be provided. Additional water supply for fire flow is not required prior to commencing vertical construction of Type I and II buildings.

3312.5 Standpipe supply. Regardless of the presence of combustible construction materials, the construction type or the fire separation distance, where a standpipe is required in accordance with Section 3313, a water supply providing a minimum flow of 500 gpm shall be provided. The fire hydrant used for this water supply shall be located

within 100 feet of the Fire Department Connection supplying the standpipe.

2018 International Building Code

SECTION 3313 WATER SUPPLY FOR FIRE PROTECTION

[F] 3313.1 Where required. An approved water supply for fire protection, either temporary or permanent, shall be made available as soon as combustible material arrives on the site, structural elements arrive on the site, upon commencement of vertical combustible construction, and upon installation of a standpipe system in buildings under construction, in accordance with Sections 3312.2 through 3312.5.

Exception: The fire code official is authorized to reduce the fire-flow requirements for isolated buildings or a group of buildings in rural areas or small communities where the development of full fire-flow requirements is impractical.

3313.2 Combustible construction elements. When combustible structural elements of the building under construction are delivered to a site, a minimum fire flow of 1,000 gpm shall be provided. The fire hydrant used to provide this fire flow supply shall be within 500 feet of the combustible structural elements, as measured along an approved fire apparatus access lane. Where the site configuration is such that one fire hydrant can not be located within 500 feet of all combustible structural elements, additional fire hydrants shall be required to provide coverage in accordance with this section.

3313.3 Vertical construction of Types III, IV, and V construction. Prior to commencement of vertical construction of Type III, IV, or V buildings that utilize any combustible structural elements, the fire flow required by Sections 3312.3.1 through 3312.3.3 shall be provided, accompanied by fire hydrants in sufficient quantity to deliver the required fire flow and proper coverage.

3313.3.1 Fire separation up to 30 feet. Where a building of Type III, IV, or V construction has a fire separation distance of less than 30 feet from property lot lines, and an adjacent property has an existing structure or otherwise can be constructed upon, the water supply shall provide either a minimum of 1,000 gpm, or the entire fire flow required for the building when constructed, whichever is greater.

3313.3.2 Fire separation of 30 feet up to 60 feet. Where a building of Type III, IV, or V construction has a fire separation distance of 30 feet up to 60 feet from property lot lines, and an adjacent property has an existing structure or otherwise can be constructed upon, the water supply shall provide a minimum of 1,000 gpm, or 50% of the fire flow required for the building when constructed, whichever is greater.

3313.3.3 Fire separation of 60 feet or greater. Where a building of Type III, IV, or V construction has a fire separation of 60 feet or greater from a property lot line, a water supply of 1,000 gpm shall be provided.

3313.4 Vertical Construction, Type I and II construction. If combustible construction materials are delivered to the construction site, water supply in accordance with Section 3312.2 shall be provided. Additional water supply for fire flow is not required prior to commencing vertical construction of Type I and II buildings.

3313.5 Standpipe supply. Regardless of the presence of combustible construction materials, the construction type or the fire separation distance, where a standpipe is required in accordance with Section 3313, a water supply providing a minimum flow of 500 gpm shall be provided. The fire hydrant used for this water supply shall be located within 100 feet of the Fire Department Connection supplying the standpipe.

2018 International Existing Building Code

SECTION 1509 WATER SUPPLY FOR FIRE PROTECTION

[F] 1509.1 When required. An approved water supply for fire protection, either temporary or permanent, shall be made available as soon as combustible material structural elements arrives on the site, upon commencement of vertical combustible construction, and upon installation of a standpipe system in buildings under construction, in accordance with Sections 3312.2 through 3312.5.

Exception: The fire code official is authorized to reduce the fire-flow requirements for isolated buildings or a group of buildings in rural areas or small communities where the development of full fire-flow requirements is impractical.

1509.2 Combustible structural elements. When combustible structural elements of the building under construction are delivered to a site, a minimum fire flow of 1,000 gpm shall be provided. The fire hydrant used to provide this fire flow supply shall be within 500 feet of the combustible structural elements, as measured along an approved fire apparatus access lane. Where the site configuration is such that one fire hydrant can not be located

within 500 feet of all combustible structural elements, additional fire hydrants shall be required to provide coverage in accordance with this section.

1509.3 Vertical construction of Types III, IV, and V construction. Prior to commencement of vertical construction of Type III, IV, or V buildings that utilize any combustible structural elements, the fire flow required by Sections 3312.3.1 through 3312.3.3 shall be provided, accompanied by fire hydrants in sufficient quantity to deliver the required fire flow and proper coverage.

1509.3.1 Fire separation up to 30 feet. Where a building of Type III, IV, or V construction has a fire separation distance of less than 30 feet from property lot lines, and an adjacent property has an existing structure or otherwise can be constructed upon, the water supply shall provide either a minimum of 1,000 gpm, or the entire fire flow required for the building when constructed, whichever is greater.

1509.3.2 Fire separation of 30 feet up to 60 feet. Where a building of Type III, IV, or V construction has a fire separation distance of 30 feet up to 60 feet from property lot lines, and an adjacent property has an existing structure or otherwise can be constructed upon, the water supply shall provide a minimum of 1,000 gpm, or 50% of the fire flow required for the building when constructed, whichever is greater.

1509.3.3 Fire separation of 60 feet or greater. Where a building of Type III, IV, or V construction has a fire separation of 60 feet or greater from a property lot line, a water supply of 1,000 gpm shall be provided.

1509.4 Vertical Construction, . Type I and II construction. If combustible construction materials are delivered to the construction site, water supply in accordance with Section 3312.2 shall be provided. Additional water supply for fire flow is not required prior to commencing vertical construction of Type I and II buildings.

1509.5 Standpipe supply. Regardless of the presence of combustible construction materials, the construction type or the fire separation distance, where a standpipe is required in accordance with Section 3313, a water supply providing a minimum flow of 500 gpm shall be provided. The fire hydrant used for this water supply shall be located within 100 feet of the Fire Department Connection supplying the standpipe.

Reason:

The current base code provides little guidance with respect to providing water supply during construction. This proposal attempts to provide requirements for providing minimum water supply for fire flow and for standpipe supply during construction.

Construction fires have been a problem recently. These fires have predominately affected combustible construction types III, IV, and V. One of the issues with construction is that water supply infrastructure is not always constructed prior to vertical construction of the building. The lack of a reliable and sufficient water supply has been a cause for many of these construction fires to cause more damage than may otherwise have occurred. The fire service can not fight fire of any significant size without a reliable water supply. It is necessary that we re-examine the way water supply is provided for buildings under construction.

Note that the provisions provided herein are not intended to require any additional water supply that would not already be required by Appendix B. The minimum fire flow that is required to be provided by Appendix B is 1,000 gpm. This proposal does not require any more than 1,000 gpm, unless the actual required fire flow for the specific building is already greater, as dictated by Appendix B. In order to ensure conformance with the fire flow requirement of Appendix B, the same exception allowing reduced fire flow from Appendix B is copied here as well.

What this proposal does is affect the timing of providing fire flow. Rather than allowing construction to start prior to establishing a water supply, as is often the case, this proposal requires that the fire flow, or a portion thereof, be provided as soon as combustible structural elements arrive at the site, and further be provided prior to vertical construction.

One should note that only structural elements are addressed. This proposal is not intended to require fire flow water supply for construction trailers, combustible forms, and the like. It is not the intent to require additional water supply during construction of non-combustible construction buildings merely due to presence of any combustibles, but rather to focus on combustible construction types.

Cost Impact

The code change proposal will increase the cost of construction .

While this proposal does not require any additional water supply that is not already required by code, it does affect the timing of providing this water supply. While the costs are difficult to quantify, affecting timing of improvements will surely have some associated costs that are not currently required without these requirements.

Analysis. The issue of water supply for fire protection at a construction site that appears in the IFC, IBC and IEBC is the responsibility of the IFC Committee. This code change proposes additional requirements for water supply relative to combustible elements and types of construction, but the subject matter remains within the same issue, therefore this code change proposed for the IFC, IBC and IEBC will be heard by the IFC committee.

Internal ID: 1133

F269-18

IFC: 3313.3; IBC: [F] 3311.3; IEBC: [F] 1506.3

Proponent: Joe McElvaney, self, representing self (joemcelvaney@gmail.com)

2018 International Fire Code

Revise as follows:

3313.3 Detailed requirements. Standpipes shall be installed in accordance with the provisions of Section 905.

Exception: Standpipes shall be either temporary or permanent in nature, and with or without a water supply, provided that such standpipes comply with the requirements of Section 905 as to capacity, pressure, outlets and materials.

2018 International Building Code

[F] 3311.3 Detailed requirements. Standpipes shall be installed in accordance with the provisions of Chapter 9.

Exception: Standpipes shall be either temporary or permanent in nature, and with or without a water supply, provided that such standpipes conform to the requirements of Section 905 as to capacity, pressure, outlets and materials.

2018 International Existing Building Code

[F] 1506.3 Detailed requirements. Standpipes shall be installed in accordance with the provisions of Chapter 9 of the International Building Code.

Exception: Standpipes shall be either temporary or permanent in nature, and with or without a water supply, provided that such standpipes conform to the requirements of Section 905 of the International Building Code as to capacity, pressure, outlets and materials.

Reason:

Currently this section has the words capacity, outlets and materials. Capacity is typically is just gmp when we are talking about water supply. in order for fire standpipe work correctly they need capacity but also need pressure. If you have 500 gpm or more at the floor level but very little outlet pressure then the nozzle will not work correctly.

If the Fire Dept apparatus can supply the water capacity and pressure to the required floor height then there is no new code requirement.

however if the Fire Dept apparatus cannot supply the water capacity and pressure to the require floor height then a temporary or permanent pump would be required.

Cost Impact

The code change proposal will increase the cost of construction .

Chapter 33 would allow several type of standpipe system, this would include (automatic wet, automatic dry, manual dry, manual wet and semiautomatic dry) as define in chapter 2 of the IFC.

If the Fire Dept apparatus can supply the water capacity and pressure to the required floor height then there is no cost increase.

However if the Fire Dept apparatus cannot supply the capacity and pressure to the required floor height due the fire pump size then the construction team would need ot work with the Fire Dept to determine the best possible way to fix this. this could include a temporary pump or permanent pump installed. this would then be a cost increase

Internal ID: 434

F270-18

IFC: 3314.1 (New); IBC: 3312.1 (New); IEBC: 1507.1 (New)

Proponent: Stephen Skalko, Stephen V. Skalko, P.E. & Associates, LLC, representing Masonry Alliance for Codes and Standards (svskalko@svskalko-pe.com)

2018 International Fire Code

Add new text as follows:

3314.1 Completion during construction. Where an automatic sprinkler system is required by this code in buildings of Type III or V construction, and will be 4 or more stories above grade plane, the portion of the building or structure that is more than 40-feet in height above fire department vehicle access shall not begin construction until automatic sprinkler protection, either temporary or permanent, is provided for all stories below. As construction progresses such automatic sprinkler protection shall be extended to within one floor of the highest point of construction having secured decking or flooring.

2018 International Building Code

Add new text as follows:

3312.1 Completion during construction. Where an automatic sprinkler system is required by this code in buildings of Type III or V construction, and will be 4 or more stories above grade plane, the portion of the building or structure that is more than 40-feet in height above fire department vehicle access shall not begin construction until automatic sprinkler protection, either temporary or permanent, is provided for all stories below. As construction progresses such automatic sprinkler protection shall be extended to within one floor of the highest point of construction having secured decking or flooring.

2018 International Existing Building Code

1507.1 Completion during construction. Where an automatic sprinkler system is required by this code in buildings of Type III or V construction, and will be 4 or more stories above grade plane, the portion of the building or structure that is more than 40-feet in height above fire department vehicle access shall not begin construction until automatic sprinkler protection, either temporary or permanent, is provided for all stories below. As construction progresses such automatic sprinkler protection shall be extended to within one floor of the highest point of construction having secured decking or flooring.

Reason:

Automatic sprinkler protection systems continue to be the major factor that permits buildings to be built to larger heights and areas as allowed in Tables 504.3, 504.4 and 506.2 of the code. With these increases there has been a notable increase in fires, especially for Group R2 Residential Occupancies constructed of combustible framing, while the building is under construction. This has resulted significant loss of property for the building under construction and nearby properties exposed to the fire in part because important fire safety features such as passive fire protection for the combustible framing is not complete and automatic sprinkler system upon which these larger and taller buildings depend are not operational.

Besides the damage to the building under construction and to nearby properties some of these fires have required major street closures including interstates, and tied up firefighting resources to the extent that other areas of the communities were left under-protected for extended periods. An example is the major fire in Los Angeles with five stories of wood framing over a two-story concrete podium on December 8, 2014 that not only resulted in millions of dollars in damage to the building under construction, but also damaged adjacent buildings. The apartment building known as the DaVinci was a complete loss after the fire that was fueled by the five stories of wood frame construction. More than 250 firefighters were dispatched to the scene. The burning of the structure's wooden frame forced the closure of northbound Harbor Freeway (Hwy 110) and affected local streets causing major traffic disruptions for commuters and to the nearby business and residences. Buildings nearby were damaged by exposure to fire from the radiant heat as well as damage inside because the fire activated sprinklers in these adjacent buildings. It has been reported that the heat also melted or damaged computers and partition cubicles in neighboring building as well. The glazing in hundreds of windows of a nearby building was also damaged.

There are numerous examples of other large combustible framed apartment and condominium building fires while the building was under construction that illustrate the fire risk these large buildings pose. The following is a list of six such incidences in 2017. This list is not necessarily inclusive of all similar large combustible building fires in 2017.

1. Metropolitan Apartments, Raleigh NC March 17, 2017- 5-story apartment on pedestal
2. The Royale at City Place, Overland Park, KS March 20, 2017 - 5-story apartments
3. Fuse 47, College Park, MD April 24, 2017 - 5-story apartment on pedestal
4. Treadmark, Boston MA, June 28, 2017 - 6-story condominiums
5. Kelowna, BC, Canada July 8, 2017 - 6-story apartments
6. Edison on the Charles, Waltham, MA July 23, 2017 - 5-story apartments

Section 3311.1 of the code requires at least one operational standpipes be in place when portions of buildings requiring standpipes are 40 feet or more above the lowest level of fire department vehicle access. This proposal takes a similar approach to the standpipe requirement for fire safety by requiring sprinkler protection, either temporary or permanent, be provided when the construction reaches the 40-foot height above the fire department vehicle access. This level of fire protection is consistent with the fire risks associated with these larger buildings of combustible construction, and upon which the building code provisions are based. Also, like the standpipe requirements, the sprinkler system must be extended as each floor is provided with decking or flooring.

Cost Impact

The code change proposal will increase the cost of construction .

This proposal is expected to increase the cost of construction due to the sprinkler protection system having to be completed on lower floors before construction can begin higher up in the building. This increased cost however is necessary to reduce the risk of damage to adjacent properties due to fire exposure which results in economic hardship for repairs and disruption to businesses and residences, to minimize the impact to the public from traffic disruptions due to the size of the conflagrations, and to reduce the demand for fire service response due to these larger taller combustible framed buildings while under construction.

Analysis: The topic covered in this proposal is scoped to the IFC Code Development committee and therefore have been added to correlate in the duplicated sections within the IBC and IEBC.

Internal ID: 2080

F271-18

IFC: Chapter 38, SECTION 3801, 3801.1, SECTION 3803, 3803.3 (New), 3803.4 (New), 5003.8.3; IBC: 307.1.1, SECTION 407, 407.12 (New)

Proponent: John Williams, Chair, representing Healthcare Committee (AHC@iccsafe.org)

2018 International Fire Code

Revise as follows:

CHAPTER 38 HIGHER EDUCATION AND HOSPITAL CLINICAL LABORATORIES

SECTION 3801 GENERAL

3801.1 Scope. Higher education and Group I-2, Condition 2 clinical laboratories complying with the requirements of this chapter shall be permitted to exceed the maximum allowable quantities of hazardous materials in *control areas* set forth in Chapter 50 without requiring classification as a Group H occupancy. Except as specified in this chapter, such laboratories shall comply with all applicable provisions of this code and the International Building Code.

SECTION 3803 GENERAL SAFETY PROVISIONS

Add new text as follows:

3803.3 Safety showers. Where more than 5 gallons (19 L) of corrosive liquid or flammable liquid are stored, handled or used, suitable facilities with fixed overhead or flexible hand-held showers shall be installed and maintained in accordance with the International Plumbing Code.

3803.4 Neutralizing or absorbing agents. Where more than 5 gallons (19 L) of corrosive liquids are stored, handled or used, a quantity of neutralizing or absorbing agents shall be provided.

Revise as follows:

5003.8.3 Control areas. *Control areas* shall comply with Sections 5003.8.3.1 through 5003.8.3.5.3.

Exception: Higher education and Group I-2, Condition 1 clinical laboratories in accordance with Chapter 38 of this code and Section 428 of the International Building Code.

2018 International Building Code

Revise as follows:

[F] 307.1.1 Uses other than Group H. An occupancy that stores, uses or handles hazardous materials as described in one or more of the following items shall not be classified as Group H, but shall be classified as the occupancy that it most nearly resembles.

1. Buildings and structures occupied for the application of flammable finishes, provided that such buildings or areas conform to the requirements of Section 416 and the International Fire Code.
2. Wholesale and retail sales and storage of flammable and combustible liquids in mercantile occupancies conforming to the International Fire Code.
3. Closed piping system containing flammable or combustible liquids or gases utilized for the operation of machinery or equipment.
4. Cleaning establishments that utilize combustible liquid solvents having a flash point of 140°F (60°C) or higher in closed systems employing equipment *listed* by an *approved* testing agency, provided that this occupancy is separated from all other areas of the building by 1-hour *fire barriers* constructed in accordance with Section 707 or 1-hour *horizontal assemblies* constructed in accordance with Section 711, or both.
5. Cleaning establishments that utilize a liquid solvent having a flash point at or above 200°F (93°C).
6. Liquor stores and distributors without bulk storage.
7. Refrigeration systems.

8. The storage or utilization of materials for agricultural purposes on the premises.
9. Stationary storage battery systems installed in accordance with the International Fire Code.
10. Corrosive personal or household products in their original packaging used in retail display.
11. Commonly used corrosive building materials.
12. Buildings and structures occupied for aerosol product storage shall be classified as Group S-1, provided that such buildings conform to the requirements of the International Fire Code.
13. Display and storage of nonflammable solid and nonflammable or noncombustible liquid hazardous materials in quantities not exceeding the maximum allowable quantity per *control area* in Group M or S occupancies complying with Section 414.2.5.
14. The storage of black powder, smokeless propellant and small arms primers in Groups M and R-3 and special industrial explosive devices in Groups B, F, M and S, provided such storage conforms to the quantity limits and requirements prescribed in the International Fire Code.
15. Stationary fuel cell power systems installed in accordance with the International Fire Code.
16. Capacitor energy storage systems in accordance with the International Fire Code.
17. Group B higher education laboratory occupancies complying with Section 428 and Chapter 38 of the International Fire Code.
18. Group I-2, Condition 2 clinical laboratories complying with Sections 407 and 428 and Chapter 38 of the International Fire Code.

SECTION 407 GROUP I-2

Add new text as follows:

407.12 Clinical laboratories.. In Group I-2, Condition 2 occupancies, clinical laboratories shall be designed and constructed in accordance with Section 428 and Chapter 38 of the International Fire Code and NFPA 45.

Reason:

The reason this code change is being proposed is because hospitals have very similar needs to academic research laboratory in terms of quantity of hazardous material, but are not addressed in the current language of Chapter 38. Understanding that Chapter 38 is intended to be a very narrow focus, expanding to clinical laboratories found in I-2, Condition 2 hospitals only slightly expands the focus of the chapter.

A clinical lab processes tests for the clinical activity of the building, such as blood test and biopsies of body tissue. Handling of biohazardous waste is an issue, which causes many clinical labs to be in basements or sub-basements, as to not traverse the rest of the hospital and provide more direct access to the loading dock for proper specimen disposal per contaminated waste disposal and chain-of-custody procedures. Current IBC and IFC codes consider these spaces High Hazard, although quantities of hazardous material are relatively low. Clinical laboratories were not considered in the Chapter 38 change last cycle, although the quantities are actually less than those described in Chapter 38 for Higher Education labs. This change seeks to add clinical laboratories, because the commonality is that both types are not high-level production (K322).

There are several types of functions of clinical laboratories: chemistry, point-of-care testing, cytology (cell analysis), specimen processing, hematology (blood testing) and anatomical pathology. These make up sections of a clinical lab with specific analyzers. Only anatomical pathology and cytology labs use flammable or hazardous material, and are commonly stored in plastic, liter sized containers. Other labs include irritants and corrosives, in similar containers.

Clinical laboratories in these spaces is limited to one or two lab areas, usually arranged as a suite, which also indicates total size, and the separation requirements are adequate based on Table 3806.2.1 for sprinklered buildings (3804.1.1 for non-sprinklered).

This proposal is submitted by the ICC Committee on Healthcare (CHC). The CHC was established by the ICC Board to evaluate and assess contemporary code issues relating to healthcare facilities. This is a joint effort between ICC and the American Society for Healthcare Engineering (ASHE), a subsidiary of the American Hospital Association, to eliminate duplication and conflicts in healthcare regulation. In 2017 the CHC held 2 open meetings and numerous conference calls, which included members of the committees as well as any interested parties, to discuss and debate the proposed changes. Information on the CHC, including: meeting agendas; minutes; reports; resource documents; presentations; and all other materials developed in conjunction with the CHC effort can be downloaded from the CHC website at: <https://www.iccsafe.org/codes-tech-support/cs/icc-committee-on-healthcare/>.

Cost Impact

The code change proposal will decrease the cost of construction .

This change decreases the cost of construction, because it eliminates a conflict between the I-codes the federal standard.

Internal ID: 712

F272-18

IFC: 3805.2.1, 3805.2.2, 3805.4, TABLE 3805.4

Proponent: Michael O'Brian, Chair, representing FCAC (fcac@iccsafe.org)

2018 International Fire Code

Revise as follows:

3805.2.1 Restricted materials storage. Where *approved* by the *fire code official*, storage of the following hazardous materials prohibited by Table 5003.1.1(1) in buildings not equipped throughout with an *automatic sprinkler system* in accordance with Section 903.3.1.1 shall be allowed within a laboratory *control area* at 25 percent of Table 5003.1.1(1) limits for a building equipped throughout with an *automatic sprinkler system*.

1. ~~Pyrophorics~~-Class 4 Oxidizers.
2. ~~Class 4 Oxidizers~~-Pyrophorics.

The percentage of the maximum allowable quantity per control shown in Table 3805.4 shall be applied to 25 percent of Table 5003.1.1(1) limits for Class 4 Oxidizers or pyrophoric materials.

Additional quantity increases shall be prohibited, and such materials shall be stored in accordance with all of the following:

1. Containers shall be completely sealed and stored in accordance with the manufacturers' recommendations.
2. Storage shall be within *approved* hazardous material storage cabinets in accordance with Section 5003.8.7, or shall be located in an inert atmosphere glove box in accordance with NFPA 45, Section 7.11.
3. The storage cabinet or *glove box* shall not contain any storage of *incompatible materials*.

3805.2.2 Restricted materials use. Where *approved* by the *fire code official*, use of the following hazardous materials prohibited by Table 5003.1.1(1) in buildings not equipped throughout with an *automatic sprinkler system* in accordance with Section 903.3.1.1, shall be allowed within a laboratory *control area* at 25 percent of Table 5003.1.1(1) limits for buildings equipped throughout with an *automatic sprinkler system*.

1. ~~Pyrophorics~~-Class 4 Oxidizers.
2. ~~Class 4 Oxidizers~~-Pyrophorics.

The percentage of the maximum allowable quantity per control area shown in Table 3805.4 shall be applied to 25 percent of Table 5003.1.1(1) limits for Class 4 Oxidizers or pyrophoric materials.

Additional quantity increases shall be prohibited, and such materials shall be stored in accordance with all of the following:

1. Use shall be within an *approved* chemical fume hood listed in accordance with UL 1805, or in an inert atmosphere glove box in accordance with NFPA 45, Section 7.11, or other *approved* equipment designed for the specific hazard of the material.
2. Combustible materials shall be kept not less than 2 feet (610 mm) away from the work area, except for those items directly related to the research.
3. A portable fire extinguisher appropriate for the specific material shall be provided within 20 feet (6096 mm) of the use in accordance with Section 906.

3805.4 Percentage of maximum allowable quantity per control area. The percentage of *maximum allowable quantities per control area* of hazardous materials shall ~~be permitted to be increased in accordance~~ comply with Table 3805.4.

**TABLE 3805.4
DESIGN AND NUMBER OF CONTROL AREAS IN EXISTING NONSPRINKLERED LABORATORIES**

FLOOR LEVEL		PERCENTAGE OF THE MAXIMUM ALLOWABLE QUANTITY PER CONTROL AREA^{a,e}	NUMBER OF CONTROL AREAS PER FLOOR	FIRE-RESISTANCE RATING FOR FIRE BARRIERS IN HOURS^{b, c, d}
Above grade plane	Higher than 9	5	1	2 ^c
	7-9	10	2	2 ^c
	4-6	25	2	2 ^c
	3	75	2	1
	1-2	100	4	1
Below grade plane	1	100	3	1
	2	75	2	1
	Lower than 2	Not Allowed	Not Allowed	Not Allowed

- a. Percentages shall be of the maximum allowable quantity per control area shown in Tables 5003.1.1(1) and 5003.1.1(2), excluding all increases allowed in the footnotes to those tables.
- b. Fire barriers shall include walls, floors and ceilings necessary to provide separation from other portions of the building.
- c. Vertical fire barriers separating control areas from other spaces on the same floor are permitted to be 1-hour fire-resistance rated.
- d. See Section 414.2.4 of the International Building Code for additional requirements.
- e. The percentage of the maximum allowable quantity per control shown in Table 3805.4 shall be applied to 25 percent of Table 5003.1.1(1) limits for Class 4 Oxidizers or pyrophoric materials.

Reason:

It was requested by those who had previously worked on this proposal to revisit the new 2018 IFC Chapter 38. It was felt that portions of the new code chapter were too easy to misapply or misinterpret. After several teleconference meetings, these changes were among those proposed to clarify the intent of the new chapter and to reorder the materials referenced in 3805.2.1 and 3805.2.2 to place them in alphabetical order. The FCAC agreed with these revisions.

This proposal is submitted by the ICC Fire Code Action Committee (FCAC). The FCAC was established by the ICC Board of Directors to pursue opportunities to improve and enhance assigned International Codes with regard to fire safety and hazardous materials in new and existing buildings and facilities and the protection of life and property in wildland urban interface areas. In 2017 the Fire-CAC has held 3 open meetings. In addition, there were numerous conference calls, Regional Work Group and Task Group meetings for the current code development cycle, which included members of the committees as well as any interested parties, to discuss and debate the proposed changes. Related documentation and reports are posted on the FCAC website at: <https://www.iccsafe.org/codes-tech-support/cs/fire-code-action-committee-fcac/>

Cost Impact

The code change proposal will not increase or decrease the cost of construction .

The proposed changes should have little to no impact on cost for achieving code compliance. These changes are believed to be needed only to clarify the intent of the current text.

Internal ID: 1886

F273-18

IFC: 3901.2

Proponent: Kevin Scott, representing KH Scott & Associates LLC (khscottassoc@gmail.com)

2018 International Fire Code

Revise as follows:

3901.2 Existing buildings or facilities. Existing buildings or facilities used for the processing of plants ~~or~~ shall comply with this chapter. Existing extraction processes where the medium of extraction or solvent is changed shall comply with this chapter.

Reason:

This proposal is a simple revision to clarify the intent of application of Chapter 39 to existing buildings.

As currently written, Section 3901.2 states that the new chapter 39 applies to:

1. Existing buildings and facilities, OR
2. Existing buildings and facilities where the extraction solvent is changed.

It either applies to ALL existing buildings, or not. If the intent was to have this chapter apply to all existing facilities, then it would not matter whether the extraction was changed or not; the existing facility must comply.

The proposed revision clarifies that the requirements apply to existing facilities where or not the extraction solvent is changed.

When those same existing facilities want to change the extraction process, those changes must also comply with this chapter. This application is consistent with Chapter 1 of the IFC which states that the requirements apply to new buildings, facilities, and operations. The change of solvent would mean of change in operations which means that the new operation must comply with the current regulations.

Cost Impact

The code change proposal will not increase or decrease the cost of construction .

This is editorial and clarifies the application of Chapter 39.

Internal ID: 2077

F274-18

IFC: 3904.2, 3904.2.1 (New), 3904.2.2 (New), 3904.2.2.1, 3904.2.2.2, 3904.2.2.3, 80

Proponent: Michael O'Brian, Chair, representing FCAC (fcac@iccsafe.org)

2018 International Fire Code

Revise as follows:

3904.2 Systems and equipment. ~~Systems or equipment used for the extraction of oils from plant material shall be listed or approved for the specific use. If the system used for extraction of oils and products from plant material is not listed, the system shall be reviewed by a registered design professional. The registered design professional shall review and consider any information provided by the system's designer or manufacturer. For systems and equipment not listed for the specific use, a technical report in accordance with Section 3904.3 shall be prepared and submitted to the fire code official for review and approval. The firm or individual preparing the technical report shall be approved by the fire code official prior to performing the analysis.~~ comply with either Section 3404.2.1 or 3404.2.2.

Add new text as follows:

3904.2.1 Listings. Systems or equipment used for the extraction of oils from plant material shall be listed and labeled in accordance with UL 1389 and installed in accordance with the listing and the manufacturer's installation instructions.

3904.2.2 Approvals. Systems or equipment used for the extraction of oils from plant material shall be approved for the specific use. The system shall be reviewed by a registered design professional. The registered design professional shall review and consider any information provided by the system's designer or manufacturer. A technical report in accordance with Section 3904.2.2.1 shall be prepared and submitted to the fire code official for review and approval. The firm or individual preparing the technical report shall be approved by the fire code official prior to performing the analysis.

Revise as follows:

~~3904.3~~**3904.2.2.1 Technical report.** A technical report, reviewed and approved by the *fire code official* as required by Section ~~3904.2~~3904.2.2, is required prior to the equipment being located or installed at the facility. The report shall be prepared by a *registered design professional* or other professional approved by the *fire code official*.

~~3904.3~~**3904.2.2.2 Report content.** The technical report shall contain all of the following:

1. Manufacturer information.
2. Preparer of record of the technical report.
3. Date of review and report revision history.
4. Signature page, including all of the following:
 - 4.1. Author of the report.
 - 4.2. Date of report.
 - 4.3. Date and signature of *registered design professional* of record performing the design or peer review.
5. Model number of the item evaluated. If the equipment is provided with a serial number, the serial number shall be included for verification at the time of site inspection.
6. Methodology of the design or peer review process used to determine minimum safety requirements. Methodology shall consider the basis of design, and shall include a code analysis and code path to demonstrate whether specific codes or standards are applicable.
7. Equipment description. A list of every component and subassembly, such as fittings, hose, quick disconnects, gauges, site glass, gaskets, valves, pumps, vessels, containers and switches, of the system or equipment, indicating the manufacturer, model number, material and solvent compatibility. Manufacturer's data sheets shall be provided.
8. A general flow schematic or general process flow diagram of the process. Post-processing or winterization shall be included in this diagram. Primary components of the process equipment shall be identified and match the equipment list required in Item 7. Operating temperatures, pressures

and solvent state of matter shall be identified in each primary step or component. A piping and instrumentation diagram (PID or P&ID) shall be provided.

9. Analysis of the vessel(s) if pressurized beyond standard atmospheric pressure. Analysis shall include purchased and fabricated components.
10. Structural analysis for the frame system supporting the equipment.
11. Process safety analysis of the extraction system, from the introduction of raw product to the end of the extraction process.
12. Comprehensive process hazard analysis considering failure modes and points of failure throughout the process. The process hazard analysis shall include a review of emergency procedure information provided by the manufacturer of the equipment or process and not that of the facility, building or room.
13. Review of the assembly instructions, operational and maintenance manuals provided by the manufacturer.
14. List of references used in the analysis.

~~3904.4~~**3904.2.2.3 Site inspection.** Prior to operation of the extraction equipment, where required by the *fire code official*, the engineer of record or *approved* professional, as *approved* in Section ~~3904.2~~**3904.2.2**, shall inspect the site of the extraction process once equipment has been installed for compliance with the technical report and the building analysis. The engineer of record or *approved* professional shall provide a report of findings and observations of the site inspection to the *fire code official* prior to the approval of the extraction process. The field inspection report authored by the engineer of record shall include the serial number of the equipment used in the process and shall confirm that the equipment installed is the same model and type of equipment identified in the technical report.

Add new standard(s) follows:

UL

Underwriters Laboratories LLC
333 Pfingsten Road
Northbrook IL 60062

1389—17:

Plant Extraction Units

Reason:

The code currently allows extraction equipment to be either listed or approved. If the equipment is not listed, approval is based on a registered design professional preparing a technical report on the equipment, followed up by a site inspection.

UL 1389 was developed to investigate plant extraction equipment that utilizes flammable solvents. This proposal adopts UL 1389 as the standard used to list extraction equipment, and reformats section 3904 to clarify that the technical report and registered design professional site inspection are only required for extraction systems that are not listed.

This proposal is submitted by the ICC Fire Code Action Committee (FCAC). The FCAC was established by the ICC Board of Directors to pursue opportunities to improve and enhance assigned International Codes with regard to fire safety and hazardous materials in new and existing buildings and facilities and the protection of life and property in wildland urban interface areas. In 2017 the Fire-CAC has held 3 open meetings. In addition, there were numerous conference calls, Regional Work Group and Task Group meetings for the current code development cycle, which included members of the committees as well as any interested parties, to discuss and debate the proposed changes. Related documentation and reports are posted on the FCAC website at: <https://www.iccsafe.org/codes-tech-support/cs/fire-code-action-committee-fcac/>

Cost Impact

The code change proposal will not increase or decrease the cost of construction .

The proposal only identifies the standard used to list extraction equipment, and does not remove the option for non-listed equipment to be provided under certain identified conditions.

Internal ID: 765

F275-18

IFC: SECTION 3905, 3905.1, 3905.1.1, 3905.1.2, 3905.1.3, 3905.1.5, 3905.2

Proponent: Michael O'Brian, Chair, representing FCAC (fcac@iccsafe.org)

2018 International Fire Code

SECTION 3905 SAFETY SYSTEMS

Revise as follows:

3905.1 Gas detection. For extraction processes utilizing flammable gases as solvents, a ~~continuous~~ gas detection system ~~complying with Section 916~~ shall be provided. ~~The gas detection threshold shall be not greater than 25 percent of the lower explosive limit/lower flammability limit (LEL/LFL) of the materials.~~

Delete without substitution:

~~**3905.1.1 System design.** The flammable gas detection system shall be *listed* or *approved* and shall be calibrated to the types of fuels or gases used for the extraction process. The gas detection system shall be designed to activate when the level of flammable gas exceeds 25 percent of the LFL.~~

~~**3905.1.2 Gas detection system components.** Gas detection system control units shall be *listed* and *labeled* in accordance with UL 864 or UL 2017. ~~2017.~~ Gas detectors shall be *listed* and *labeled* in accordance with UL 2075 for use with the gases and vapors being detected.~~

Revise as follows:

~~3905.1.~~**3905.1.2 Operation.** Activation of the gas detection system shall result in all the following:

1. Initiation of distinct audible and visual alarm signals in the extraction room.
2. Deactivation of all heating systems located in the extraction room.
3. Activation of the mechanical ventilation system, where the system is interlocked with gas detection.
4. ~~Activation of the gas detection system shall disable all light switches and electrical outlets.~~

~~3905.1.4~~**3905.1.3 Failure of the gas detection system.** Failure of the gas detection system shall result in the deactivation of the heating system; activation of the mechanical ventilation system where the system is interlocked with the gas detection system; and initiation of a trouble signal to sound in an *approved* location.

Delete without substitution:

~~**3905.1.5 Interlocks.** Electrical components within the extraction room shall be interlocked with the gas detection system. Activation of the gas detection system shall disable all light switches and electrical outlets.~~

3905.2 Emergency shutoff. Extraction processes utilizing gaseous hydrocarbon-based solvents shall be provided with emergency shutoff systems in accordance with Section 5803.1.3.

Reason:

Last cycle F75-16 included a comprehensive rewrite of gas detection system requirements. This proposal does not change when and where gas detection is required in Chapter 39, but merely correlates the requirements with the remaining IFC gas detection system requirements. Section 916 includes requirements for the gas detection system and components, and covers the 25% LFL detection threshold.

This proposal is submitted by the ICC Fire Code Action Committee (FCAC). The FCAC was established by the ICC Board of Directors to pursue opportunities to improve and enhance assigned International Codes with regard to fire safety and hazardous materials in new and existing buildings and facilities and the protection of life and property in wildland urban interface areas. In 2017 the Fire-CAC has held 3 open meetings. In addition, there were numerous conference calls, Regional Work Group and Task Group meetings for the current code development cycle, which included members of the committees as well as any interested parties, to discuss and debate the proposed changes. Related documentation and reports are posted on the FCAC website at: <https://www.iccsafe.org/codes-tech-support/cs/fire-code-action-committee-fcac/>

Cost Impact

The code change proposal will not increase or decrease the cost of construction .

This correlates this new chapters gas detection systems with F75-16. It should not change the cost or possibly reduce as the gas detction requirements will be more specific to the process being regulated.

Internal ID: 290

F276-18

IBC: 307.1.1, 311.2, 311.3;

IFC: 903.2.4.2 (New) (IBC:[F]903.2.4.2), 903.2.9.3 (New) (IBC:[F]903.2.9.3), Chapter 40 (New), 5001.1, 5701.2

IMC: [F] 502.9.5

Proponent: Michael O'Brian, Chair, representing FCAC (fcac@iccsafe.org); Ed Kullik, Chair, representing ICC Building Code Action Committee (bcac@iccsafe.org)

2018 International Building Code

Revise as follows:

[F] 307.1.1 Uses other than Group H. An occupancy that stores, uses or handles hazardous materials as described in one or more of the following items shall not be classified as Group H, but shall be classified as the occupancy that it most nearly resembles.

1. Buildings and structures occupied for the application of flammable finishes, provided that such buildings or areas conform to the requirements of Section 416 and the International Fire Code.
2. Wholesale and retail sales and storage of flammable and combustible liquids in mercantile occupancies conforming to the International Fire Code.
3. Closed piping system containing flammable or combustible liquids or gases utilized for the operation of machinery or equipment.
4. Cleaning establishments that utilize combustible liquid solvents having a flash point of 140°F (60°C) or higher in closed systems employing equipment *listed* by an *approved* testing agency, provided that this occupancy is separated from all other areas of the building by 1-hour *fire barriers* constructed in accordance with Section 707 or 1-hour *horizontal assemblies* constructed in accordance with Section 711, or both.
5. Cleaning establishments that utilize a liquid solvent having a flash point at or above 200°F (93°C).
6. Liquor stores and distributors without bulk storage.
7. Refrigeration systems.
8. The storage or utilization of materials for agricultural purposes on the premises.
9. Stationary storage battery systems installed in accordance with the International Fire Code.
10. Corrosive personal or household products in their original packaging used in retail display.
11. Commonly used corrosive building materials.
12. Buildings and structures occupied for aerosol product storage shall be classified as Group S-1, provided that such buildings conform to the requirements of the International Fire Code.
13. Display and storage of nonflammable solid and nonflammable or noncombustible liquid hazardous materials in quantities not exceeding the maximum allowable quantity per *control area* in Group M or S occupancies complying with Section 414.2.5.
14. The storage of black powder, smokeless propellant and small arms primers in Groups M and R-3 and special industrial explosive devices in Groups B, F, M and S, provided such storage conforms to the quantity limits and requirements prescribed in the International Fire Code.
15. Stationary fuel cell power systems installed in accordance with the International Fire Code.
16. Capacitor energy storage systems in accordance with the International Fire Code.
17. Group B higher education laboratory occupancies complying with Section 428 and Chapter 38 of the International Fire Code
18. Distilling or brewing of beverages conforming to the requirements of the International Fire Code.
19. The storage of beer, distilled spirits and wines in barrels and casks conforming to the requirements of the International Fire Code.

311.2 Moderate-hazard storage, Group S-1. Storage Group S-1 occupancies are buildings occupied for storage uses that are not classified as Group S-2, including, but not limited to, storage of the following:

- Aerosol products, Levels 2 and 3

- Aircraft hangar (storage and repair)
- Bags: cloth, burlap and paper
- Bamboos and rattan
- Baskets
- Belting: canvas and leather
- Beverages: over 16-percent alcohol content
- Books and paper in rolls or packs
- Boots and shoes
- Buttons, including cloth covered, pearl or bone
- Cardboard and cardboard boxes
- Clothing, woolen wearing apparel
- Cordage
- Dry boat storage (indoor)
- Furniture
- Furs
- Glues, mucilage, pastes and size
- Grains
- Horns and combs, other than celluloid
- Leather
- Linoleum
- Lumber
- Motor vehicle repair garages complying with the maximum allowable quantities of hazardous materials listed in Table 307.1(1) (see Section 406.8)
- Photo engravings
- Resilient flooring
- Self-service storage facility (mini-storage)
- Silks
- Soaps
- Sugar
- Tires, bulk storage of
- Tobacco, cigars, cigarettes and snuff
- Upholstery and mattresses
- Wax candles

311.3 Low-hazard storage, Group S-2. Storage Group S-2 occupancies include, among others, buildings used for the storage of noncombustible materials such as products on wood pallets or in paper cartons with or without single thickness divisions; or in paper wrappings. Such products are permitted to have a negligible amount of plastic *trim*, such as knobs, handles or film wrapping. Group S-2 storage uses shall include, but not be limited to, storage of the following:

- Asbestos
- Beverages up to and including 16-percent alcohol ~~in metal, glass or ceramic containers~~
- Cement in bags
- Chalk and crayons
- Dairy products in nonwaxed coated paper containers
- Dry cell batteries
- Electrical coils

- Electrical motors
- Empty cans
- Food products
- Foods in noncombustible containers
- Fresh fruits and vegetables in nonplastic trays or containers
- Frozen foods
- Glass
- Glass bottles, empty or filled with noncombustible liquids
- Gypsum board
- Inert pigments
- Ivory
- Meats
- Metal cabinets
- Metal desks with plastic tops and *trim*
- Metal parts
- Metals
- Mirrors
- Oil-filled and other types of distribution transformers
- Parking garages, open or enclosed
- Porcelain and pottery
- Stoves
- Talc and soapstones
- Washers and dryers

2018 International Fire Code

Add new text as follows:

903.2.4.2 Group F-1 Distilled Spirits. An automatic sprinkler system shall be provided throughout a Group F-1 fire area used for the manufacture of distilled spirits.

903.2.9.3 Group S-1 Distilled spirits or wine. An automatic sprinkler system shall be provided throughout a Group S-1 fire area used for the bulk storage of distilled spirits or wine.

CHAPTER 40 STORAGE OF DISTILLED SPIRITS AND WINES

SECTION 4001 GENERAL

4001.1 General. The storage of distilled spirits and wines in barrels and casks shall comply with this chapter in addition to other applicable requirements of this code.

4001.1.1 Nonapplicability. Chapter 50 and Chapter 57 of this code are not applicable to the storage of distilled spirits and wines in barrels and casks as identified in Section 5001.1, Exception 10, and Section 5701.2, Item 10.

SECTION 4002 DEFINITIONS

4002.1 Terms defined in Chapter 2. Words and terms used in this chapter and defined in Chapter 2 shall have the meanings ascribed to them as defined therein.

4003 PRECAUTIONS AGAINST FIRE

4003.1 Spill Control. Drainage or containment systems shall be provided by means of curbs, scuppers, special drains, or other suitable means to prevent the flow of spills throughout the building.

4003.2 Ventilation. Ventilation shall be provided for rooms and spaces where distilled spirits and wines in barrels and casks are stored in accordance with the International Mechanical Code and one of the following:

1. The rooms and spaces shall be ventilated at a rate sufficient to maintain the concentration of vapors within the area at or below 25% of the LFL . This shall be confirmed by sampling of the actual vapor concentration under normal operating conditions. The sampling shall be conducted throughout the enclosed storage area extending to or toward the bottom and the top of the enclosed storage area. The vapor concentration used to determine the required ventilation rate shall be the highest measured concentration during the sampling procedure. The sampling shall be conducted manually or by installation of a continuously monitoring flammable vapor detection system.
2. The rooms and spaces shall be provided exhaust ventilation at a rate of not less than 1 cfm/ft² (0.3 m³/min) of solid floor area. The exhaust ventilation shall be accomplished by natural or mechanical means, with discharge of the exhaust to a safe location outside the building.

4003.3 Sources of ignition.. Sources of ignition shall be controlled in accordance with Sections 4003.3.1 through 4003.4.

4003.3.1 Smoking. Smoking shall be prohibited and "No Smoking" signs provided as follows:

1. In rooms or areas where hazardous materials are stored or dispensed or used in open systems in amounts requiring a permit in accordance with Section 105.6 and 105.7
2. Within 25 feet (7620mm) of outdoor storage, dispensing or open use areas.
3. Facility or areas within facilities that have been designated as totally "no smoking" shall have "No Smoking" signs placed at all entrances to the facility or area. Designated areas within such facilities where smoking is permitted either permanently or temporarily shall be identified with signs designating that smoking is permitted in these areas only.
4. In rooms or areas where flammable or combustible hazardous materials are stored, dispensed or used.

Signs required by this section shall be in English as a primary language or in symbols allowed by this code and shall comply with Section 310.

4003.3.2 Open Flame. Open flames and high-temperature devices shall not be used in a manner that creates a hazardous condition and shall be listed for use with the hazardous materials stored or used.

4003.3.3 Industrial trucks. Powered industrial trucks used in areas designated as hazardous (classified) locations in accordance with NFPA 70 shall be listed and labeled for use in the environment intended in accordance with NFPA 505.

4003.3.4 Electrical. Electrical wiring and equipment shall be installed and maintained in accordance with Section 605 and NFPA 70.

4003.4 Lightning. Structures containing barrel storage should be protected from lightning. The lightning protection equipment shall be installed in accordance with NFPA 780 and NFPA 70.

SECTION 4004 STORAGE

4004.1 Storage. Storage shall be in accordance with this section and Section 315.

4004.2 Empty containers. The storage of empty containers previously used for the storage of flammable or combustible liquids, unless free from explosive vapors, shall be stored as required for filled containers.

4004.3 Basement storage. Class I liquids shall be allowed to be stored in basements in amounts not exceeding the maximum allowable quantity over control area for use-open systems in Table 5003.1.1(1), provided that automatic suppression and other fire protection are provided in accordance with Chapter 9. Class II and IIIA liquids shall also be allowed to be stored in basements, provided that automatic suppression and other fire protection are provided in accordance with Chapter 9.

4004.4 Bulk beverage storage areas. There shall be no storage of combustible materials in the bulk beverage storage areas not related to the beverage storage activities.

SECTION 4005 FIRE PROTECTION

4005.1 Automatic sprinkler system. The storage of distilled spirits and wines shall be protected by an approved automatic sprinkler system as required by Chapter 9.

4005.2 Portable Fire Extinguishers. Approved portable fire extinguishers shall be provided in accordance with Section 906.

SECTION 4006 SIGNAGE

4006.1 Hazard identification signs. Unless otherwise exempted by the fire code official, visible hazard identification signs as specified in NFPA 704 for the specific material contained shall be placed on stationary containers and above ground tanks and at entrances to locations where hazardous materials are stored, dispensed, used or handled in quantities requiring a permit and at specific entrances and locations designated by the fire code official.

4006.1.1 Maintenance and style. Signs and markings required by Section 4006.1 shall not be obscured or removed, shall be in English as a primary language or in symbols allowed by this code, shall be durable, and the size, color, and lettering shall be approved.

Revise as follows:

5001.1 Scope. Prevention, control and mitigation of dangerous conditions related to storage, dispensing, use and handling of hazardous materials shall be in accordance with this chapter.

This chapter shall apply to all hazardous materials, including those materials regulated elsewhere in this code, except that where specific requirements are provided in other chapters, those specific requirements shall apply in accordance with the applicable chapter. Where a material has multiple hazards, all hazards shall be addressed.

Exceptions:

1. In retail or wholesale sales occupancies, the quantities of medicines, foodstuff or consumer products and cosmetics containing not more than 50 percent by volume of water-miscible liquids and with the remainder of the solutions not being flammable shall not be limited, provided that such materials are packaged in individual containers not exceeding 1.3 gallons (5 L).
2. Quantities of alcoholic beverages in retail or wholesale sales occupancies shall not be limited providing the liquids are packaged in individual containers not exceeding 1.3 gallons (5 L).
3. Application and release of pesticide and agricultural products and materials intended for use in weed abatement, erosion control, soil amendment or similar applications where applied in accordance with the manufacturers' instructions and label directions.
4. The off-site transportation of hazardous materials where in accordance with Department of Transportation (DOTn) regulations.
5. Building materials not otherwise regulated by this code.
6. Refrigeration systems (see Section 605).
7. Stationary storage battery systems regulated by Section 1206.2.
8. The display, storage, sale or use of fireworks and *explosives* in accordance with Chapter 56.
9. *Corrosives* utilized in personal and household products in the manufacturers' original consumer packaging in Group M occupancies.
10. The storage of beer, distilled spirits and wines in ~~wooden~~ barrels and casks.
11. The use of wall-mounted dispensers containing alcohol-based hand rubs classified as Class I or II liquids where in accordance with Section 5705.5.

5701.2 Nonapplicability. This chapter shall not apply to liquids as otherwise provided in other laws or regulations or chapters of this code, including:

1. Specific provisions for flammable liquids in motor fuel-dispensing facilities, repair garages, airports and marinas in Chapter 23.
2. Medicines, foodstuffs, cosmetics and commercial or institutional products containing not more than 50 percent by volume of water-miscible liquids and with the remainder of the solution not being

flammable, provided that such materials are packaged in individual containers not exceeding 1.3 gallons (5 L).

3. Quantities of alcoholic beverages in retail or wholesale sales or storage occupancies, provided that the liquids are packaged in individual containers not exceeding 1.3 gallons (5 L).
4. Storage and use of fuel oil in tanks and containers connected to oil-burning equipment. Such storage and use shall be in accordance with Section 603. For abandonment of fuel oil tanks, this chapter applies.
5. Refrigerant liquids and oils in refrigeration systems (see Section 605).
6. Storage and display of aerosol products complying with Chapter 51.
7. Storage and use of liquids that do not have a fire point when tested in accordance with ASTM D92.
8. Liquids with a *flash point* greater than 95°F (35°C) in a water-miscible solution or dispersion with a water and inert (noncombustible) solids content of more than 80 percent by weight, which do not sustain combustion.
9. Liquids without *flash points* that can be flammable under some conditions, such as certain halogenated hydrocarbons and mixtures containing halogenated hydrocarbons.
10. The storage of ~~beer~~, distilled spirits and wines in ~~wooden~~ barrels and casks.
11. Commercial cooking oil storage tank systems located within a building and designed and installed in accordance with Section 608 and NFPA 30.

2018 International Mechanical Code

Revise as follows:

[F] 502.9.5 Flammable and combustible liquids. Exhaust ventilation systems shall be provided as required by Sections 502.9.5.1 through 502.9.5.5 for the storage, use, dispensing, mixing and handling of flammable and combustible liquids. Unless otherwise specified, this section shall apply to any quantity of flammable and combustible liquids.

~~Exception~~ **Exceptions:**

1. This section shall not apply to flammable and combustible liquids that are exempt from the International Fire Code.
2. The storage of beer, distilled spirits and wines in barrels and casks conforming to the requirements of the International Fire Code.

Reason:

Currently, due to changes over several code change cycles, there is confusion on how to treat distilled spirits and wines as a Group in the International Building Code and for applicable safety requirements of the International Fire Code. Coordination between the codes on this subject is important because distilled spirits still have the properties of flammable liquids and proper safeguards must be provided for the occupancies housing such activities.

[F] COMBUSTIBLE LIQUID. A liquid having a closed cup flash point at or above 100°F (38°C). Combustible liquids shall be subdivided as follows:

Class II. Liquids having a closed cup flash point at or above 100°F (38°C) and below 140°F (60°C).

Class IIIA. Liquids having a closed cup flash point at or above 140°F (60°C) and below 200°F (93°C).

Class IIIB. Liquids having a closed cup flash point at or above 200°F (93°C).

The category of combustible liquids does not include compressed gases or cryogenic fluids.

[F] FLAMMABLE LIQUID. A liquid having a closed cup flash point below 100°F (38°C). Flammable liquids are further categorized into a group known as Class I liquids. The Class I category is subdivided as follows:

Class IA. Liquids having a flash point below 73°F (23°C) and a boiling point below 100°F (38°C).

Class IB. Liquids having a flash point below 73°F (23°C) and a boiling point at or above 100°F (38°C).

Class IC. Liquids having a flash point at or above 73°F (23°C) and below 100°F (38°C). The category of flammable liquids does not include compressed gases or cryogenic fluids.

Image-1-Alcohol-Levels



Image-2-Alcohol-Levels



The International Building Code classifies the various activities into Groups. The manufacturing of beverages with over 16 percent alcohol is classified as an F-1 and the manufacturing of beverages 16 percent alcohol or less is classified as an F-2:

306.2 Moderate-hazard factory industrial, Group F-1. Factory industrial uses that are not classified as Factory Industrial F-2 Low Hazard shall be classified as F-1 Moderate Hazard and shall include, but not be limited to, the following:

Beverages: over 16-percent alcohol content

306.3 Low-hazard factory industrial, Group F-2. Factory industrial uses that involve the fabrication or manufacturing of noncombustible materials that during finishing, packing or processing do not involve a significant fire hazard shall be classified as F-2 occupancies and shall include, but not be limited to, the following:

Beverages: up to and including 16-percent alcohol content

The storage of beverages with up to and including 16-percent alcohol in metal, glass or ceramic containers is classified as an S-2:

311.3 Low -hazard storage, Group S-2. Storage Group S-2 occupancies include, among others, buildings used for the storage of noncombustible materials such as products on wood pallets or in paper cartons with or without single thickness divisions; or in paper wrappings. Such products are permitted to have a negligible amount of plastic trim, such as knobs, handles or film wrapping. Group S-2 storage uses shall include, but not be limited to, storage of the following:

Beverages up to and including 16-percent alcohol in metal, glass or ceramic containers

However, there is no Group S classification listed for storage of beverages with over 16 percent alcohol and there are no listed "Uses other than Group H" for distilling activities or bulk storage of distilled spirits in Section 307 High Hazard Group H.

311.2 Moderate-hazard storage, Group S-1. Storage Group S-1 occupancies are buildings occupied for storage uses that are not classified as Group S-2, including, but not limited to, storage of the following:

???

[F] 307.1.1 Uses other than Group H. An occupancy that stores, uses or handles hazardous materials as described in one or more of the following items shall not be classified as Group H, but shall be classified as the occupancy that it most nearly resembles.

2. Wholesale and retail sales and storage of flammable and combustible liquids in mercantile occupancies conforming to the International Fire Code.

6. Liquor stores and distributors without bulk storage.

The lack of a S-1 Group designation for storage activities for beverages over 16-percent alcohol or any bulk storage recognition and the lack of recognition under "Uses other than Group H" causes disputes between code officials as to application of a Group H to storage of the finished product after it leaves the Factory group process.

In the International Fire Code there is confusion about the applicability of Chapter 50 Hazardous Materials-General Provisions and Chapter 57 Flammable and Combustible Liquids provisions to distilled spirits because of the exception for distilled spirits and wines stored in wooden barrels and casks in IFC Chapters 50 and 57. The issue is arising because of the growing popularity of "boutique" or "craft" distillers.

A review of the International Fire Code Commentary concerning the distilled spirits in wooden barrels exception finds the following statement which highlights the conflict between the codes:

5001.1 Scope.

Prevention, control and mitigation of dangerous conditions related to storage, dispensing, use and handling of hazardous materials shall be in accordance with this chapter.

This chapter shall apply to all hazardous materials, including those materials regulated elsewhere in this code, except that where specific requirements are provided in other chapters, those specific requirements shall apply in accordance with the applicable chapter. Where a material has multiple hazards, all hazards shall be addressed.

Exceptions:

10. The storage of distilled spirits and wines in wooden barrels and casks.

IFC Commentary:

"Exception 10 covers the storage of distilled spirits and wines in wooden barrels and casks. This statement may appear to exempt all requirements for these products from being a Group H occupancy. However, the IBC will still classify the storage area as a Group H occupancy if the amounts exceed the maximum allowable quantities (MAQs) per control area listed in Table 307.1(1) of that code for flammable or combustible liquids. All requirements for a Group H occupancy in the IBC are still applicable; however, any requirements from the code (fire code) are not."

5701.1 Scope and application. Prevention, control and mitigation of dangerous conditions related to storage, use,

dispensing, mixing and handling of flammable and combustible liquids shall be in accordance with Chapter 50 and this chapter.

5701.2 Nonapplicability. This chapter shall not apply to liquids as otherwise provided in other laws or regulations or chapters of this code, including:

10. The storage of distilled spirits and wines in wooden barrels and casks.

IFC Commentary:

“Item 10 makes the storage of distilled spirits and wines in wooden barrels and casks exempt from this chapter. Although their contents are classified as flammable liquids, the containers do not pose the rupture hazard that other containers do. Barrels and casks will leak their contents and contribute to the fire as the metal bands that secure the staves expand and loosen. Even this hazard feature is generally mitigated by the operation of automatic sprinklers that prevent the fire from progressing to the point where the metal bands get hot enough to expand. A similar exception also appears in Section 5001.1.”

In summary, when you manufacture distilled spirits you are an F-1 occupancy. When you manufacture wine or beer you are an F-2 occupancy. When you store wine and beer you are an S-2 occupancy. When you store distilled spirits in retail packaging you are not an H occupancy but there is no clarifying entry under S-1. If you store any beverage with over 16% alcohol in bulk, (includes some wines), you have an H occupancy. As far as risk goes, manufacturing has a higher risk than storage for an event, yet manufacturing of distilled spirits is an F-1 regardless of amount but an H if stored in bulk. This makes no sense. To top it off, when you go to the IFC, if you store your distilled spirits in bulk in wooden barrels Chapter 50 and 57 do not apply so there are no code requirements.

This proposal attempts to address this confusion recognizing the main safety issues are the need for automatic fire suppression, the need for mechanical ventilation and need for containment of spills. In 2005 the Distilled Spirits Council of The United States (DISCUS) released recommended guidelines for these facilities which addressed fire protection, ventilation and secondary containment requirements. Those guidelines were consulted in drafting the new chapter proposed for the International Fire Code.

It is proposed to make the following Group designation changes to the International Building Code:

Add a classification under S-1 for storage of beverages over 16% alcohol whether in bulk or retail packaging.

Modify the classification under S-2 to apply to all beverages up to and including 16-percent alcohol regardless of container type.

Modify Section [F] 307.1.1 “Uses other than Group H” to add classifications for distilling, brewing or storage of these materials.

In the International Fire Code, it is proposed to strike the word “wooden” and addition of the “word beer” in the exceptions in Chapters 50 and 57:

10. The storage of beer, distilled spirits and wines in ~~wooden~~ barrels and casks.

In the International Mechanical Code it is proposed to strike the word “wooden” from Section [F] 502.9.5 “Flammable and combustible liquids”.

In conjunction with the Group classification cleanup and striking the word wooden in both the IFC and IMC, protection features will be addressed by establishing new sprinkler thresholds for the manufacture of distilled spirits or bulk storage of distilled spirits regardless of square footage along with the creation of a new chapter in the International Fire Code for the Storage of Distilled Spirits and Wines.

This proposal is submitted by the ICC Fire Code Action Committee (FCAC) and the ICC Building Code Action Committee (BCAC). The FCAC was established by the ICC Board of Directors to pursue opportunities to improve and enhance assigned International Codes with regard to fire safety and hazardous materials in new and existing buildings and facilities and the protection of life and property in wildland urban interface areas. In 2017 the Fire-CAC has held 3 open meetings. In addition, there were numerous conference calls, Regional Work Group and Task Group meetings for the current code development cycle, which included members of the committees as well as any interested parties, to discuss and debate the proposed changes. Related documentation and reports are posted on the FCAC website at: <https://www.iccsafe.org/codes-tech-support/cs/fire-code-action-committee-fcac/>. BCAC was established by the ICC Board of Directors in July 2011 to pursue opportunities to improve and enhance assigned International Codes or portions thereof. In 2017 the BCAC has held 3 open meetings. In addition, there were numerous Working Group meetings and conference calls for the current code development cycle, which included members of the committee as well as any interested party to discuss and debate the proposed changes. Related documentation and reports are posted on the BCAC website at: <https://www.iccsafe.org/codes-tech-support/codes/code-development-process/building-code-action-committee-bcac>.

Bibliography:

Recommended Fire Protection Practices for Distilled Spirits Beverage Facilities, Third Edition

Prepared Under the Auspices of The Distilled Spirits Council of the United States, Inc.

<http://www.discus.org/policy/fireprotection/>

Cost Impact

The code change proposal will not increase or decrease the cost of construction .

This proposal will likely break even on the cost of construction by clarifying what the appropriate Group designation is, elimination of the unnecessary H classifications, and clarifying what protection levels are necessary.

Internal ID: 182

F277-18

IFC: 202, Chapter 40 (New), Chapter 80

Proponent: Joe Scibetta, representing Self (jscibetta@buildingreports.com)

2018 International Fire Code

Add new definition as follows:

ANIMAL HOUSING FACILITY Area of a building or structure, including interior and adjacent exterior spaces, where animals are fed, rested, worked, exercised, treated, exhibited, or used for production.

Add new text as follows:

CHAPTER 40 ANIMAL HOUSING FACILITIES

4001 GENERAL

4001.1 Scope. Fire protection for animal housing facilities, including agricultural buildings where livestock and poultry are housed, shall comply with the provisions of this chapter.

4002 DEFINITION

4002.1 Definitions. The following term is defined in Chapter 2:
ANIMAL HOUSING FACILITY

4003 PRECAUTIONS

4003.1 Sources of Ignition. Smoking or the use of heating or other devices employing an open flame, or the use of spark-producing equipment is prohibited in all areas of an animal housing facility, including agricultural buildings housing livestock or poultry.

4003.2 Waste Removal and Housekeeping. A procedure to ensure cleanliness and orderliness, including the removal of animal waste, shall be maintained. Permanent storage shall be prohibited in aisles, hallways, or other types of corridors.

4004 FIRE PROTECTION AND LIFE SAFETY

4004.1 Standards. Animal housing facilities shall be in accordance with the applicable provisions of the standards referenced in Table 4004.1..

Table 4004.1
Fire and Life Safety Standards for Animal Housing

Standard	Subject
NFPA 101	The Life Safety Code
NFPA 150	Standard on Fire and Life Safety in Animal Housing Facilities

Add new standard(s) follows:

NFPA

National Fire Protection Association
1 Batterymarch Park
Quincy MA 02169-7471

150-16:

Standard on Fire and Life Safety in Animal Housing Facilities

Reason:

Currently, the IFC does not recognize this special type of occupancy. While housing for poultry and livestock in agricultural buildings is addressed, non-agricultural facilities where animals are housed and attended to by humans are not addressed. This proposed chapter would address the fire protection and life safety concerns in all types of animal housing, including agricultural buildings that house poultry and livestock. It is important for the IFC to recognize the special operations that take place in these unique facilities, where a secondary population is wholly reliant on a primary population for the necessary, prompt attention required during a fire emergency. This language will allow the IFC to correlate with NFPA 1 and NFPA 101, which both address this special occupancy, and will provide a vital directional path from the IFC to the only standard in our industry that addresses the specific requirements for fire protection and life safety in an animal housing facility, namely NFPA 150. Such correlation and recognition by the IFC would be vital in advancing the work of property protection and life safety in this important sector of our industry.

Cost Impact

The code change proposal will not increase or decrease the cost of construction .

These facilities already exist but are simply not yet addressed in the IFC. This would not affect the cost of construction as these facilities should already be complying with the referenced standards. Also in some cases the requirements of this chapter are operational and not related to construction.

Internal ID: 131

F278-18

IFC: 5001.1, 5701.2, 202

Proponent: Ellie Klausbruckner, Klausbruckner & Associates Inc., representing Klausbruckner & Associates, Inc. (ek@klausbruckner.com)

2018 International Fire Code

Revise as follows:

5001.1 Scope. Prevention, control and mitigation of dangerous conditions related to storage, dispensing, use and handling of hazardous materials shall be in accordance with this chapter.

This chapter shall apply to all hazardous materials, including those materials regulated elsewhere in this code, except that where specific requirements are provided in other chapters, those specific requirements shall apply in accordance with the applicable chapter. Where a material has multiple hazards, all hazards shall be addressed.

Exceptions:

1. ~~In retail or wholesale sales occupancies, the quantities of medicines, foodstuff, cosmetics and commercial or consumer institutional products and cosmetics containing not more than 50 percent by volume of water-miscible liquids and with the remainder of the solutions not being flammable shall not be limited, provided that such materials are packaged in individual containers not exceeding 1.3 gallons (5 L).~~
2. ~~Quantities of alcoholic beverages in retail or wholesale sales occupancies shall not be limited providing~~
provided that the liquids are packaged in individual containers not exceeding 1.3 gallons (5 L).
3. Application and release of pesticide and agricultural products and materials intended for use in weed abatement, erosion control, soil amendment or similar applications where applied in accordance with the manufacturers' instructions and label directions.
4. The off-site transportation of hazardous materials where in accordance with Department of Transportation (DOTn) regulations.
5. Building materials not otherwise regulated by this code.
6. Refrigerant liquids and oils in refrigeration systems (see Section 605).
7. Stationary storage battery systems regulated by Section 1206.2.
8. The display, storage, sale or use of fireworks and *explosives* in accordance with Chapter 56.
9. *Corrosives* utilized in personal and household products in the manufacturers' original consumer packaging in Group M occupancies.
10. The storage of distilled spirits and wines in wooden barrels and casks.
11. The use of wall-mounted dispensers containing alcohol-based hand rubs classified as Class I or II liquids where in accordance with Section 5705.5.
12. Flammable liquids in motor fuel-dispensing facilities, repair garages, airports and marinas in Chapter 23.
13. Storage and use of fuel oil in tanks and containers connected to oil-burning equipment. Such storage and use shall be in accordance with Section 603. For abandonment of fuel oil tanks, Chapter 57 applies.
14. Storage and display of aerosol products complying with Chapter 51.
15. Storage and use of flammable or combustible liquids that do not have a fire point when tested in accordance with ASTM D92, not otherwise regulated by this code.
16. Flammable or combustible liquids with a flash point greater than 95°F (35°C) in a water-miscible solution or dispersion with a water and inert (noncombustible) solids content of more than 80 percent by weight, which do not sustain combustion, not otherwise regulated by this code.
17. Commercial cooking oil storage tank systems located within a building and designed and installed in accordance with Section 608 and NFPA 30.

5701.2 Nonapplicability. This chapter shall not apply to liquids as otherwise provided in other laws or regulations or chapters of this code, including:

1. ~~Specific provisions for~~ Flammable liquids in motor fuel-dispensing facilities, repair garages, airports and marinas in Chapter 23.
2. Medicines, foodstuffs, cosmetics and commercial or institutional products containing not more than 50 percent by volume of water-miscible liquids and with the remainder of the solution not being flammable, provided that such materials are packaged in individual containers not exceeding 1.3 gallons (5 L).
3. Quantities of alcoholic beverages in retail or wholesale sales or storage occupancies, provided that the liquids are packaged in individual containers not exceeding 1.3 gallons (5 L).
4. Storage and use of fuel oil in tanks and containers connected to oil-burning equipment. Such storage and use shall be in accordance with Section 603. For abandonment of fuel oil tanks, this chapter applies.
5. Refrigerant liquids and oils in refrigeration systems (see Section 605).
6. Storage and display of aerosol products complying with Chapter 51.
7. Storage and use of liquids that do not have a fire point when tested in accordance with ASTM D92.
8. Liquids with a *flash point* greater than 95°F (35°C) in a water-miscible solution or dispersion with a water and inert (noncombustible) solids content of more than 80 percent by weight, which do not sustain combustion.
9. Liquids without *flash points* that can be flammable under some conditions, such as certain halogenated hydrocarbons and mixtures containing halogenated hydrocarbons.
10. The storage of distilled spirits and wines in wooden barrels and casks.
11. Commercial cooking oil storage tank systems located within a building and designed and installed in accordance with Section 608 and NFPA 30.
12. Application and release of pesticide and agricultural products and materials intended for use in weed abatement, erosion control, soil amendment or similar applications where applied in accordance with the manufacturers' instructions and label directions.
13. The off-site transportation of flammable or combustible liquids where in accordance with Department of Transportation (DOTn) regulation.

COMBUSTIBLE LIQUID.

FLAMMABLE LIQUID.

Reason:

The intent of this code change is to match language in the exceptions under applicability in Chapters 50 and 57 as much as possible. For example there is an exception for motor fuel dispensing and repair garages in Chapter 57. We believe it was intended to be exempt out of both Chapter 50 and 57. Otherwise the quantities of fuels would have to be applied against the MAQs in Chapter 50.

With some of the exceptions (for example Exceptions 15 in Chapter 50) additional language was added to clarify that if (for example) you have a flammable liquid with no fire point, but if that liquid is also a toxic, that this liquid is not exempted. Therefore "not otherwise regulated by this code" was added to the language.

The definition of flammable and combustible liquids (Chapter 57) have been changed to exclude liquids without a fire point. The **fire point** of a liquid is the lowest temperature at which the vapour of that fuel will continue to burn for at least 5 seconds after ignition by an open flame. At the flash point, a lower temperature, a substance will ignite briefly, but the vapors cannot sustain the fire if the liquid does not have a fire point. This is why liquids with no fire point have always been excluded out of the Chapter 57 (under applicability) with the intention of not classifying these liquids as flammable or combustible. For example most beers contain 4%-12% ethanol may have a flashpoint, but in most cases do not have a fire point when tested. However, this is not reflected in Chapter 50 where the MAQs are assessed, nor in the definitions. It is only added to the exceptions in Chapter 57.

Cost Impact

The code change proposal will not increase or decrease the cost of construction .

This code change is providing consistency to the language. It is not intended to increase or decrease the cost to construction, but to provide clarification on what should have been applied all along.

Internal ID: 2297

F279-18

IFC: 5001.1, 6001.1

Proponent: Ellie Klausbruckner, Klausbruckner & Associates, Inc, representing Klausbruckner & Associates, Inc. (ek@klausbruckner.com)

2018 International Fire Code

5001.1 Scope. Prevention, control and mitigation of dangerous conditions related to storage, dispensing, use and handling of hazardous materials shall be in accordance with this chapter.

This chapter shall apply to all hazardous materials, including those materials regulated elsewhere in this code, except that where specific requirements are provided in other chapters, those specific requirements shall apply in accordance with the applicable chapter. Where a material has multiple hazards, all hazards shall be addressed.

Exceptions:

1. In retail or wholesale sales occupancies, the quantities of medicines, foodstuff or consumer products and cosmetics containing not more than 50 percent by volume of water-miscible liquids and with the remainder of the solutions not being flammable shall not be limited, provided that such materials are packaged in individual containers not exceeding 1.3 gallons (5 L).
2. Quantities of alcoholic beverages in retail or wholesale sales occupancies shall not be limited providing the liquids are packaged in individual containers not exceeding 1.3 gallons (5 L).
3. Application and release of pesticide and agricultural products and materials intended for use in weed abatement, erosion control, soil amendment or similar applications where applied in accordance with the manufacturers' instructions and label directions as follows:
 - 3.1 Application or release of liquids and solids indoors
 - 3.2 Application or release of liquids, solids and gases outdoors
 - 3.3 Application or release of gases indoors in an approved manner.
4. The off-site transportation of hazardous materials where in accordance with Department of Transportation (DOTn) regulations.
5. Building materials not otherwise regulated by this code.
6. Refrigeration systems (see Section 605).
7. Stationary storage battery systems regulated by Section 1206.2.
8. The display, storage, sale or use of fireworks and *explosives* in accordance with Chapter 56.
9. *Corrosives* utilized in personal and household products in the manufacturers' original consumer packaging in Group M occupancies.
10. The storage of distilled spirits and wines in wooden barrels and casks.

Revise as follows:

6001.1 Scope. The storage and use of highly toxic and toxic materials shall comply with this chapter. *Compressed gases* shall also comply with Chapter 53.

Exceptions:

1. Display and storage in Group M and storage in Group S occupancies complying with Section 5003.11.
2. Conditions involving pesticides or agricultural products as follows:
 - 2.1. Application and release of pesticide, agricultural products and materials intended for use in weed abatement, erosion control, soil amendment or similar applications when applied in accordance with the manufacturer's instruction and label directions as follows:
 - 2.1.1. Application or release of liquids and solids indoors,
 - 2.1.2. Application or release of liquids, solids and gases outdoors,
 - 2.1.3. Application or release of gases indoors in an approved manner

- 2.2. Transportation of pesticides in compliance with the Federal Hazardous Materials Transportation Act and regulations thereunder.

Reason:

More and more indoor marijuana growing facilities are heating sulfur to produce sulfur dioxide, a highly toxic gas. Sulfur dioxide is used as a form of pesticide. Safety methods should be negotiated with AHJs prior to the use/release of highly toxic gases. Issues to consider are:

Methods of warning occupants during the release.

Methods of warning fire fighters in the event of an incident.

Methods of detection, warning and evacuation in the event of a gas leak out of growing rooms into adjacent rooms.

Cost Impact

The code change proposal will increase the cost of construction .

Since application or release of gases indoor may result in the AHJs requiring additional safety measures, this will most likely result in an increase in cost of construction.

Internal ID: 2359

F280-18

IBC: [F] 307.1, TABLE 307.1(1); IFC: 5003.1, 5003.1.1, TABLE 5003.1.1(1)

Proponent: Michael O'Brian (FCAC@iccsafe.org)

2018 International Building Code

[F] 307.1 High-hazard Group H. High-hazard Group H occupancy includes, among others, the use of a building or structure, or a portion thereof, that involves the manufacturing, processing, generation or storage of materials that constitute a physical or health hazard in quantities in excess of those allowed in *control areas* complying with Section 414, based on the maximum allowable quantity limits for *control areas* set forth in Tables 307.1(1) and 307.1(2). Hazardous occupancies are classified in Groups H-1, H-2, H-3, H-4 and H-5 and shall be in accordance with this section, the requirements of Section 415 and the International Fire Code. Hazardous materials stored, or used on top of roofs or canopies, shall be classified as outdoor storage or use and shall comply with the International Fire Code.

Revise as follows:

TABLE 307.1(1)

MAXIMUM ALLOWABLE QUANTITY PER CONTROL AREA OF HAZARDOUS MATERIALS POSING A PHYSICAL HAZARDa, j, m, n, p

MATERIAL	CLASS	GROUP WHEN THE MAXIMUM ALLOWABLE QUANTITY IS EXCEEDED	STORAGE ^b			USE-CLOSED SYSTEMS ^b			USE-OPEN SYSTEMS ^b		
			Solid pounds(cubic feet)	Liquid gallons (pounds)	Gas (cubic feet at NTP)	Solid pounds(cubic feet)	Liquid gallons (pounds)	Gas (cubic feet at NTP)	Solid pounds(cubic feet)	Liquid gallons (pounds)	
Combustible dust ^q	NA	H-2	SeeNote-q	NA	NA	SeeNote-q	NA	NA	SeeNote-q	NA	
Combustible fiber ^r	Loose Baled ^r	H-3	(100) (1,000)	NA	NA	(100) (1,000)	NA	NA	(20) (200)	NA	
Combustible liquid ^{c, i}	II	H-2 or H-3	NA	120 ^{d, e}	NA	NA	120 ^d	NA	NA	30 ^d	
	IIA	H-2 or H-3		330 ^{d, e}							80 ^d
	IIB	NA		13,200 ^{d, f}							3,300 ^f
Cryogenic flammable	NA	H-2	NA	45 ^d	NA	NA	45 ^d	NA	NA	10 ^d	
Cryogenic inert	NA	NA	NA	NA	NL	NA	NA	NL	NA	NA	
Cryogenic oxidizing	NA	H-3	NA	45 ^d	NA	NA	45 ^d	NA	NA	10 ^d	
			e, g	e, g		g	g		g	g	
			e, g	e, g		g	g		g	g	
			e, g	e, g		g	g		g	g	
			e, g	e, g		g	g		g	g	
			e, f								
			e, g	e, g		g	g		g	g	
			e, g								
Flammable gas	Gaseous	H-2	NA	NA	1,000 ^{d, e}	NA	NA	1,000 ^{d, e}	NA	NA	
	Liquefied			(150) ^{d, e}	NA		(150) ^{d, e}	NA			
Flammable liquid ^c	IA	H-2 or H-3	NA	30 ^{d, e}	NA	NA	30 ^d	NA	NA	10 ^d	
	IB and IC			120 ^{d, e}							30 ^d
Flammable liquid, combination (IA, IB, IC)	NA	H-2 or H-3	NA	120 ^{d, e, h}	NA	NA	120 ^{d, h}	NA	NA	30 ^{d, h}	
Flammable solid	NA	H-3	125 ^{d, e}	NA	NA	125 ^d	NA	NA	25 ^d	NA	
Inert gas	Gaseous	NA	NA	NA	NL	NA	NA	NL	NA	NA	
	Liquefied	NA	NA	NA	NL	NA	NA	NL	NA	NA	
Organic peroxide	UD	H-1	1 ^{e, g}	(1) ^{e, g}	NA	0.25 ^g	(0.25) ^g	NA	0.25 ^g	(0.25) ^g	
	I	H-2	5 ^{e, e}	(5) ^{e, e}		1 ^d	(1) ^d		1 ^d	(1) ^d	
	II	H-3	50 ^{d, e}	(50) ^{d, e}		50 ^d	(50) ^d		10 ^d	(10) ^d	
	III	H-3	125 ^{d, e}	(125) ^{d, e}		125 ^d	(125) ^d		25 ^d	(25) ^d	
	IV	NA	NL	NL		NL	NL		NL	NL	
	V	NA	NL	NL		NL	NL		NL	NL	
Oxidizer	4	H-1	1 ^g	(1) ^{e, g}	NA	0.25 ^g	(0.25) ^g	NA	0.25 ^g	(0.25) ^g	
	3 ^f	H-2 or H-3	10 ^{d, e}	(10) ^{d, e}		2 ^d	(2) ^d		2 ^d	(2) ^d	
	2	H-3	250 ^{d, e}	(250) ^{d, e}		250 ^d	(250) ^d		50 ^d	(50) ^d	
	1	NA	4,000 ^{e, f}	(4,000) ^{e, f}		4,000 ^f	(4,000) ^f		1,000 ^f	(1,000) ^f	
Oxidizing gas	Gaseous	H-3	NA	NA	1,500 ^{d, e}	NA	NA	1,500 ^{d, e}	NA	NA	
	Liquefied			(150) ^{d, e}	NA		(150) ^{d, e}	NA			
Pyrophoric	NA	H-2	4 ^{e, g}	(4) ^{e, g}	50 ^{e, g}	1 ^g	(1) ^g	10 ^{e, g}	0	0	
Unstable (reactive)	4	H-1	1 ^{e, g}	(1) ^{e, g}	10 ^{e, g}	0.25 ^g	(0.25) ^g	2 ^{e, g}	0.25 ^g	(0.25) ^g	
	3	H-1 or H-2	5 ^{d, e}	(5) ^{d, e}	50 ^{d, e}	1 ^d	(1) ^d	10 ^{d, e}	1 ^d	(1) ^d	
	2	H-3	50 ^{d, e}	(50) ^{d, e}	750 ^{d, e}	50 ^d	(50) ^d	750 ^{d, e}	10 ^d	(10) ^d	
	1	NA	NL	NL	NL	NL	NL	NL	NL	NL	
Water reactive	3	H-2	5 ^{d, e}	(5) ^{d, e}	NA	5 ^d	(5) ^d	NA	1 ^d	(1) ^d	
	2	H-3	50 ^{d, e}	(50) ^{d, e}		50 ^d	(50) ^d		10 ^d	(10) ^d	
	1	NA	NL	NL		NL	NL		NL	NL	

For SI: 1 cubic foot = 0.028 m³, 1 pound = 0.454 kg, 1 gallon = 3.785 L.

NL = Not Limited; NA = Not Applicable; UD = Unclassified Detonable.

- a. For use of control areas, see Section 414.2.
- b. The aggregate quantity in use and storage shall not exceed the quantity listed for storage.
- c. The quantities of alcoholic beverages in retail and wholesale sales occupancies shall not be limited provided the liquids are packaged in individual containers not exceeding 1.3 gallons. In retail and wholesale sales occupancies, the quantities of medicines, foodstuffs or consumer products, and cosmetics containing not more than 50 percent by volume of water-miscible liquids with the remainder of the solutions not being flammable, shall not be limited, provided that such materials are packaged in individual containers not exceeding 1.3 gallons.
- d. Maximum allowable quantities shall be increased 100 percent in buildings equipped throughout with an automatic sprinkler system in accordance with Section 903.3.1.1. Where Note e also applies, the increase for both notes shall be applied accumulatively.
- e. Maximum allowable quantities shall be increased 100 percent when stored in approved storage cabinets, day boxes, gas cabinets, gas rooms or exhausted enclosures or in listed safety cans in accordance with Section 5003.9.10 of the International Fire Code. Where Note d also applies, the increase for both notes shall be applied accumulatively.
- f. Quantities shall not be limited in a building equipped throughout with an automatic sprinkler system in accordance with Section 903.3.1.1.
- g. Allowed only in buildings equipped throughout with an automatic sprinkler system in accordance with Section 903.3.1.1.
- h. Containing not more than the maximum allowable quantity per control area of Class IA, IB or IC flammable liquids.
- i. The maximum allowable quantity shall not apply to fuel oil storage complying with Section 603.3.2 of the International Fire Code.
- j. Quantities in parentheses indicate quantity units in parentheses at the head of each column.
- k. A maximum quantity of 220 pounds of solid or 22 gallons of liquid Class 3 oxidizers is allowed when such materials are necessary for maintenance purposes, operation or sanitation of equipment when the storage containers and the manner of storage are approved.
- l. Net weight of the pyrotechnic composition of the fireworks. Where the net weight of the pyrotechnic composition of the fireworks is not known, 25 percent of the gross weight of the fireworks, including packaging, shall be used.
- m. For gallons of liquids, divide the amount in pounds by 10 in accordance with Section 5003.1.2 of the International Fire Code.
- n. For storage and display quantities in Group M and storage quantities in Group S occupancies complying with Section 414.2.5, see Tables 414.2.5(1) and 414.2.5(2).
- ~~o. Densely packed baled cotton that complies with the packing requirements of ISO 8115 shall not be included in this material class.~~
- p. The following shall not be included in determining the maximum allowable quantities:
 1. Liquid or gaseous fuel in fuel tanks on vehicles.
 2. Liquid or gaseous fuel in fuel tanks on motorized equipment operated in accordance with the International Fire Code.
 3. Gaseous fuels in piping systems and fixed appliances regulated by the International Fuel Gas Code.
 4. Liquid fuels in piping systems and fixed appliances regulated by the International Mechanical Code.
 5. Alcohol-based hand rubs classified as Class I or II liquids in dispensers that are installed in accordance with Sections 5705.5 and 5705.5.1 of the International Fire Code. The location of the alcohol-based hand rub (ABHR) dispensers shall be provided in the construction documents.
- ~~q. Where manufactured, generated or used in such a manner that the concentration and conditions create a fire or explosion hazard based on information prepared in accordance with Section~~

2018 International Fire Code

5003.1 Scope. The storage, use and handling of all hazardous materials shall be in accordance with this section.

5003.1.1 Maximum allowable quantity per control area. The *maximum allowable quantity per control area* shall be as specified in Tables 5003.1.1(1) through 5003.1.1(4).

For retail and wholesale storage and display in Group M occupancies and Group S storage, see Section 5003.11.

Revise as follows:

TABLE 5003.1.1(1)
MAXIMUM ALLOWABLE QUANTITY PER CONTROL AREA OF HAZARDOUS MATERIALS POSING A PHYSICAL HAZARD^a, j, m, n, p

MATERIAL	CLASS	GROUP WHEN THE MAXIMUM ALLOWABLE QUANTITY IS EXCEEDED	STORAGE ^b			USE-CLOSED SYSTEMS ^b			USE-OPEN SYSTEMS ^b	
			Solid pounds(cubic feet)	Liquid gallons (pounds)	Gas (cubic feet at NTP)	Solid pounds(cubic feet)	Liquid gallons (pounds)	Gas (cubic feet at NTP)	Solid pounds(cubic feet)	Liquid gallons (pounds)
Combustible dust	NA	H-2	See-Note-g	NA	NA	See-Note-g	NA	NA	See-Note-g	NA
Combustible fibers ^h	Loose-Boiled ^g	H-3	(300)	NA	NA	(300)	NA	NA	(200)	NA
			(3,000)			(3,000)			(200)	
Combustible liquid ^{h, i}	I	H-2 or H-3	NA	120 ^{k, c}	NA	NA	NA	NA	NA	30 ^l
	IIA	H-2 or H-3		330 ^{k, c}						80 ^l
	IIIB	NA		33,200 ^{k, f}						3,300 ^l
Cryogenic Flammable	NA	H-2	NA	45 ^d	NA	NA	NA	NA	NA	10 ^d
Cryogenic Inert	NA	NA	NA	NA	NL	NA	NA	NL	NA	NA
Cryogenic Oxidizing	NA	H-3	NA	45 ^d	NA	NA	NA	NA	NA	10 ^d
Explosives	Division 1.1	H-1	1 ^{n, g}	(1) ^{n, g}	NA	0.25 ^f	(0.25) ^f	NA	0.25 ^f	(0.25) ^f
	Division 1.2	H-1	1 ^{n, g}	(1) ^{n, g}		0.25 ^f	(0.25) ^f		0.25 ^f	(0.25) ^f
	Division 1.3	H-1 or H-2	5 ^{n, g}	(5) ^{n, g}		1 ^f	(1) ^f		1 ^f	(1) ^f
	Division 1.4	H-3	50 ^{n, g}	(50) ^{n, g}		50 ^f	(50) ^f		NA	NA
	Division 1.4G	H-3	125 ^{n, l}	NA		NA	NA		NA	NA
	Division 1.5	H-1	1 ^{n, g}	(1) ^{n, g}		0.25 ^f	(0.25) ^f		0.25 ^f	(0.25) ^f
	Division 1.6	H-1	1 ^{n, g}	NA		NA	NA		NA	NA
Flammable Gas	Gaseous	H-2	NA	NA	1,000 ^{k, m}	NA	NA	1,000 ^{k, m}	NA	NA
	Liquefied			(150) ^{k, m}	NA		(150) ^{k, m}	NA		
Flammable liquid ^h	IA	H-2 or H-3	NA	30 ^{k, n}	NA	NA	NA	NA	NA	10 ^d
	II and IC			120 ^{k, n}			120 ^{k, n}			30 ^d
Flammable liquid, combination (A, B, IC)	NA	H-2 or H-3	NA	120 ^{k, n, h}	NA	NA	NA	NA	NA	30 ^{k, h}
Flammable solid	NA	H-3	125 ^{k, c}	NA	NA	125 ^o	NA	NA	25 ^o	NA
Inert Gas	Gaseous	NA	NA	NA	NL	NA	NA	NL	NA	NA
	Liquefied	NA	NA	NA	NL	NA	NA	NL	NA	NA
Organic peroxide	III	H-1	1 ^{n, g}	(1) ^{n, g}	NA	0.25 ^f	(0.25) ^f	NA	0.25 ^f	(0.25) ^f
	I	H-2	5 ^{n, m}	(5) ^{n, m}		1 ^f	(1) ^f		1 ^f	(1) ^f
	II	H-3	50 ^{k, m}	(50) ^{k, m}		50 ^f	(50) ^f		10 ^d	(10) ^d
	III	H-3	125 ^{k, m}	(125) ^{k, m}		125 ^o	(125) ^o		25 ^o	(25) ^o
	IV	NA	NL	NL		NL	NL		NL	NL
	V	NA	NL	NL		NL	NL		NL	NL
Oxidizer	4	H-1	1 ^o	(1) ^{n, g}	NA	0.25 ^f	(0.25) ^f	NA	0.25 ^f	(0.25) ^f
	3 ^h	H-2 or H-3	10 ^{k, m}	(10) ^{k, m}		2 ^f	(2) ^f		2 ^f	(2) ^f
	2	H-3	250 ^{k, c}	(250) ^{k, c}		250 ^o	(250) ^o		50 ^o	(50) ^o
	1	NA	4,000 ^{n, f}	(4,000) ^{n, f}		4,000 ^o	(4,000) ^o		1,000 ^o	(1,000) ^o
Oxidizing Gas	Gaseous	H-3	NA	NA	1,500 ^{k, c}	NA	NA	1,500 ^{k, c}	NA	NA
	Liquefied			(150) ^{k, c}	NA		(150) ^{k, c}	NA		
Pyrophoric	NA	H-2	4 ^{n, m}	(4) ^{n, m}	50 ^{n, f}	1 ^f	(1) ^f	10 ^{n, f}	0	0
Unstable (reactive)	4	H-1	1 ^{n, g}	(1) ^{n, g}	30 ^{n, f}	0.25 ^f	(0.25) ^f	2 ^{n, g}	0.25 ^f	(0.25) ^f
	3	H-1 or H-2	5 ^{n, m}	(5) ^{n, m}	50 ^{n, m}	1 ^f	(1) ^f	10 ^{n, m}	1 ^f	(1) ^f
	2	H-3	50 ^{k, m}	(50) ^{k, m}	750 ^{n, m}	50 ^f	(50) ^f	750 ^{n, m}	10 ^d	(10) ^d
	1	NA	NL	NL	NL	NL	NL	NL	NL	NL
Water reactive	3	H-2	5 ^{n, m}	(5) ^{n, m}	NA	5 ^f	(5) ^f	NA	1 ^f	(1) ^f
	2	H-3	50 ^{k, m}	(50) ^{k, m}		50 ^f	(50) ^f		10 ^d	(10) ^d
	1	NA	NL	NL		NL	NL		NL	NL

For SI: 1 cubic foot = 0.02832 m³, 1 pound = 0.454 kg, 1 gallon = 3.785 L.

NA = Not Applicable, NL = Not Limited, UD = Unclassified Detonable.

- a. For use of control areas, see Section 5003.8.3.
- b. The aggregate quantity in use and storage shall not exceed the quantity listed for storage.
- c. The quantities of alcoholic beverages in retail and wholesale sales occupancies shall not be limited providing the liquids are packaged in individual containers not exceeding 1.3 gallons. In retail and wholesale sales occupancies, the quantities of medicines, foodstuff or consumer products and cosmetics containing not more than 50 percent by volume of water-miscible liquids with the remainder of the solutions not being flammable shall not be limited, provided that such materials are packaged in individual containers not exceeding 1.3 gallons.
- d. Maximum allowable quantities shall be increased 100 percent in buildings equipped throughout with an approved automatic sprinkler system in accordance with Section 903.3.1.1. Where Note e applies, the increase for both notes shall be applied accumulatively.
- e. Maximum allowable quantities shall be increased 100 percent where stored in approved storage cabinets, day boxes, gas cabinets, gas rooms, exhausted enclosures or in listed safety cans in accordance with Section 5003.9.10. Where Note d applies, the increase for both notes shall be applied accumulatively.
- f. Quantities shall not be limited in a building equipped throughout with an approved automatic sprinkler system in accordance with Section 903.3.1.1.
- g. Allowed only in buildings equipped throughout with an approved automatic sprinkler system.
- h. Containing not more than the maximum allowable quantity per control area of Class IA, Class IB or Class IC flammable liquids.
- i. The maximum allowable quantity shall not apply to fuel oil storage complying with Section 603.3.2.
- j. Quantities in parenthesis indicate quantity units in parenthesis at the head of each column. storage containers and the manner of storage are approved.
- l. Net weight of pyrotechnic composition of the fireworks. Where the net weight of the pyrotechnic composition of the fireworks is not known, 25 percent of the gross weight of the fireworks including packaging shall be used.
- m. For gallons of liquids, divide the amount in pounds by 10 in accordance with Section 5003.1.2.
- n. For storage and display quantities in Group M and storage quantities in Group S occupancies complying with Section 5003.11, see Table 5003.11.1.
- ~~o. Densely packed baled cotton that complies with the packing requirements of ISO 8115 shall not be included in this material class.~~
- p. The following shall not be included in determining the maximum allowable quantities:
 1. Liquid or gaseous fuel in fuel tanks on vehicles.
 2. Liquid or gaseous fuel in fuel tanks on motorized equipment operated in accordance with this code.
 3. Gaseous fuels in piping systems and fixed appliances regulated by the International Fuel Gas Code.
 4. Liquid fuels in piping systems and fixed appliances regulated by the International Mechanical Code.
 5. Alcohol-based hand rubs classified as Class I or II liquids in dispensers that are installed in accordance with Sections 5705.5 and 5705.5.1. The location of the alcohol-based hand rub (ABHR) dispensers shall be provided in the construction documents.
- ~~q. Where manufactured, generated or used in such a manner that the concentration and conditions create a fire or explosion hazard based on information prepared in accordance with Section 104.7.2.~~

Reason:

This proposal is follow up work correlating the IBC and IFC provisions with the work done on Chapter 22 Combustible Dust and Chapter 37 Combustible Fibers in the IFC along with Section 426 of the IBC.

The proposal seeks to delete the MAQ listing of dust and combustible fibers from IBC Table 307.1(1) and IFC Table 5003.1.1(1).

The key reason for deleting the listings is because combustible dust is typically not a hazardous material, a small percentage may also be, but the dust hazard classification is not a hazardous material issue. The same for combustible fibers.

Table 5003.1.1(1) is the source table for IBC Table 307.1(1) and Chapter 50 of the IFC only applies to Hazardous Materials.

2018 IFC

“SECTION 5001

GENERAL

5001.1 Scope. Prevention, control and mitigation of dangerous conditions related to storage, dispensing, use and handling of hazardous materials shall be in accordance with this chapter. This chapter shall apply to all hazardous materials, including those materials regulated elsewhere in this code, except that where specific requirements are provided in other chapters, those specific requirements shall apply in accordance with the applicable chapter. Where a material has multiple hazards, all hazards shall be addressed.”

Likewise, Section 5003 of the IFC only applies to hazardous materials.

2018 IFC

“SECTION 5003

GENERAL REQUIREMENTS

5003.1 Scope. The storage, use and handling of all hazardous materials shall be in accordance with this section.”

So, though dust and combustible fibers are listed in the MAQ tables, the tables do not apply to any non-hazardous material dust or combustible fiber based upon the scoping of the code language.

It should be noted that Combustible Dust was not listed in the MAQ tables until the 2012 edition of the IFC/IBC and that the requirements for combustible fibers were moved from Chapter 52 into a new Chapter 37 starting with the 2015 edition of the IFC specifically because combustible fibers are not a hazardous material. (See code change F301-13) The same problem occurs within the scoping of Section 307 High-Hazard Group H in the Building Code.

2018 IBC

“SECTION 307

HIGH-HAZARD GROUP H

[F] 307.1 High-hazard Group H. High-hazard Group H occupancy includes, among others, the use of a building or structure, or a portion thereof, that involves the manufacturing, processing, generation or storage of materials that constitute a physical or health hazard in quantities in excess of those allowed in control areas complying with Section 414, based on the maximum allowable quantity limits for control areas set forth in Tables 307.1(1) and 307.1(2). Hazardous occupancies are classified in Groups H-1, H-2, H-3, H-4 and H-5 and shall be in accordance with this section, the requirements of Section 415 and the International Fire Code. Hazardous materials stored, or used on top of roofs or canopies, shall be classified as outdoor storage or use and shall comply with the International Fire Code.”

“[F] HAZARDOUS MATERIALS. Those chemicals or substances that are physical hazards or health hazards as classified in Section 307 and the International Fire Code, whether the materials are in usable or waste condition.”

“[F] HEALTH HAZARD. A classification of a chemical for which there is statistically significant evidence that acute or chronic health effects are capable of occurring in exposed persons. The term “health hazard” includes chemicals that are toxic or highly toxic, and corrosive.”

“[F] PHYSICAL HAZARD. A chemical for which there is evidence that it is a combustible liquid, cryogenic fluid, explosive, flammable (solid, liquid or gas), organic peroxide (solid or liquid), oxidizer (solid or liquid), oxidizing gas, pyrophoric (solid, liquid or gas), unstable (reactive) material (solid, liquid or gas) or water-reactive material (solid or liquid).”

By scoping and definition, Section 307 applies to hazardous materials, chemicals. Combustible dust and combustible fiber hazards are not hazardous material or chemical hazards. So, in applying Section 307 on H Group occupancies you can only apply the requirements to those combustible dusts or combustible fibers that also happen to be chemicals.

The second reason for the change is that the hazard is not an MAQ related hazard. It doesn't matter how much combustible dust or combustible fibers are present. You can have tons of material present without a hazard being presented or you can have a small amount with a hazard presented. It is how the material is manufactured, generated or used in an occupancy that can create a fire or explosion hazard.

This was attempted to be addressed by the addition of note q to the table with similar language added to the occupancy descriptors under Group H-2 and Group H-3.

2018 IBC

"q. Where manufactured, generated or used in such a manner that the concentration and conditions create a fire or explosion hazard based on information prepared in accordance with Section 414.1.3."

2018 IFC

"q. Where manufactured, generated or used in such a manner that the concentration and conditions create a fire or explosion hazard based on information prepared in accordance with Section 104.7.2."

In the IFC the note points to Section 104.7.2 which provides no guidance other than pointing out the fire code official can require a technical opinion and report. The added language also did not change the fact that this portion of the IBC and the Table in the IFC are scoped to hazardous materials and chemicals. This scoping problem also relates to the reference to information prepared in accordance with Section 414.1.3.

The field use of the language is subjective causing application where the hazard does not exist because the tables indicate any amount of combustible dust is a hazard and for combustible dust and the low threshold for combustible fibers, (note that combustible fibers includes combustible dust as a hazard).

Deletion of the listing for combustible dust and combustible fibers will eliminate an incorrect listing based upon the hazardous materials scoping of this portion of the code and eliminate incorrect application of the code to these materials. This does not eliminate or impact the Chapters and Sections of the IBC and IFC that effectively manage the hazards that can be presented by the materials based upon their use.

Cost Impact

The code change proposal will decrease the cost of construction .

The cost of construction will decrease by eliminating inaccurate application of the code to these materials.

Internal ID: 1554

F281-18

IFC: TABLE 5003.1.1(1); IBC: TABLE 307.1(1)

Proponent: William Koffel, representing American Pyrotechnics Association (wkoffel@koffel.com)

2018 International Fire Code

Revise as follows:

TABLE 5003.1.1(1)

MAXIMUM ALLOWABLE QUANTITY PER CONTROL AREA OF HAZARDOUS MATERIALS POSING A PHYSICAL HAZARDa, j, m, n, p

MATERIAL	CLASS	GROUP WHEN THE MAXIMUM ALLOWABLE QUANTITY IS EXCEEDED	STORAGE ^b			USE-CLOSED SYSTEMS ^b			USE-OPEN SYSTEMS ^b	
			Solid pounds (cubic feet)	Liquid gallons (pounds)	Gas (cubic feet at NTP)	Solid pounds (cubic feet)	Liquid gallons (pounds)	Gas (cubic feet at NTP)	Solid pounds (cubic feet)	Liquid gallons (pounds)
Combustible dust	NA	H-2	See Note q	NA	NA	See Note q	NA	NA	See Note q	NA
Combustible fibers ^o	Loose	H-3	(100)	NA	NA	(100)	NA	NA	(20)	NA
	Baled ⁱ		(1,000)			(1,000)			(200)	
Combustible liquid ¹	II	H-2 or H-3	NA	120 ^{d, e}	NA	NA	120 ^d	NA	NA	30 ^d
	IIA	H-2 or H-3		330 ^{d, e}			330 ^d			80 ^d
	IIB	NA		13,200 ^{e, f}			13,200 ^d			3,300 ^d
Cryogenic flammable	NA	H-2	NA	45 ^d	NA	NA	45 ^d	NA	NA	10 ^d
Cryogenic inert	NA	NA	NA	NA	NL	NA	NA	NL	NA	NA
Cryogenic Oxidizing	NA	H-3	NA	45 ^d	NA	NA	45 ^d	NA	NA	10 ^d
Explosives	Division 1.1	H-1	1 ^{e, g}	(1) ^{e, g}	NA	0.25 ^g	(0.25) ^g	NA	0.25 ^g	(0.25) ^g
	Division 1.2	H-1	1 ^{e, g}	(1) ^{e, g}		0.25 ^g	(0.25) ^g		0.25 ^g	(0.25) ^g
	Division 1.3	H-1 or H-2	5 ^{e, g}	(5) ^{e, g}		1 ^g	(1) ^g		1 ^g	(1) ^g
	Division 1.4	H-3	50 ^{e, g}	(50) ^{e, g}		50 ^g	(50) ^g		NA	NA
	Division 1.4G	H-3	125 ^{d, e, f}	NA		NA	NA		NA	NA
	Division 1.5	H-1	1 ^{e, g}	(1) ^{e, g}		0.25 ^g	(0.25) ^g		0.25 ^g	(0.25) ^g
	Division 1.6	H-1	1 ^{e, g}	NA		NA	NA		NA	NA
Flammable gas	Gaseous	H-2	NA	NA	1,000 ^{d, e}	NA	NA	1,000 ^{d, e}	NA	NA
	Liquefied			(150) ^{d, e}	NA		(150) ^{d, e}	NA		
Flammable liquid ²	IA	H-2 or H-3	NA	30 ^{d, e}	NA	NA	30 ^d	NA	NA	10 ^d
	IB and IC			120 ^{e, e}			120 ^d			30 ^d
Flammable liquid combination (IA, IB, IC)	NA	H-2 or H-3	NA	120 ^{d, e, h}	NA	NA	120 ^{d, h}	NA	NA	30 ^{d, h}
Flammable solid	NA	H-3	125 ^{d, e}	NA	NA	125 ^d	NA	NA	25 ^d	NA
Inert Gas	Gaseous	NA	NA	NA	NL	NA	NA	NL	NA	NA
	Liquefied	NA	NA	NA	NL	NA	NA	NL	NA	NA
Organic peroxide	UD	H-1	1 ^{e, g}	(1) ^{e, g}	NA	0.25 ^g	(0.25) ^g	NA	0.25 ^g	(0.25) ^g
	I	H-2	5 ^{d, e}	(5) ^{d, e}		1 ^d	(1) ^d		1 ^d	(1) ^d
	II	H-3	50 ^{d, e}	(50) ^{d, e}		50 ^d	(50) ^d		10 ^d	(10) ^d
	III	H-3	125 ^{d, e}	(125) ^{d, e}		125 ^d	(125) ^d		25 ^d	(25) ^d
	IV	NA	NL	NL		NL	NL		NL	NL
	V	NA	NL	NL		NL	NL		NL	NL
Oxidizer	4	H-1	1 ^g	(1) ^{e, g}	NA	0.25 ^g	(0.25) ^g	NA	0.25 ^g	(0.25) ^g
	3 ^h	H-2 or H-3	10 ^{d, e}	(10) ^{d, e}		2 ^g	(2) ^g		2 ^g	(2) ^g
	2	H-3	250 ^{d, e}	(250) ^{d, e}		250 ^d	(250) ^d		50 ^d	(50) ^d
	1	NA	4,000 ^{e, f}	(4,000) ^{e, f}		4,000 ^d	(4,000) ^d		1,000 ^d	(1,000) ^d
Oxidizing gas	Gaseous	H-3	NA	NA	1,500 ^{d, e}	NA	NA	1,500 ^{d, e}	NA	NA
	Liquefied			(150) ^{d, e}	NA		(150) ^{d, e}	NA		
Pyrophoric	NA	H-2	4 ^{e, g}	(4) ^{e, g}	50 ^{e, g}	1 ^g	(1) ^g	10 ^{e, g}	0	0
Unstable (reactive)	4	H-1	1 ^{e, g}	(1) ^{e, g}	10 ^{e, g}	0.25 ^g	(0.25) ^g	2 ^{e, g}	0.25 ^g	(0.25) ^g
	3	H-1 or H-2	5 ^{d, e}	(5) ^{d, e}	50 ^{d, e}	1 ^d	(1) ^d	10 ^{d, e}	1 ^d	(1) ^d
	2	H-3	50 ^{d, e}	(50) ^{d, e}	750 ^{d, e}	50 ^d	(50) ^d	750 ^{d, e}	10 ^d	(10) ^d
	1	NA	NL	NL	NL	NL	NL	NL	NL	NL
Water reactive	3	H-2	5 ^{d, e}	(5) ^{d, e}	NA	5 ^d	(5) ^d	NA	1 ^d	(1) ^d
	2	H-3	50 ^{d, e}	(50) ^{d, e}		50 ^d	(50) ^d		10 ^d	(10) ^d
	1	NA	NL	NL		NL	NL		NL	NL

For SI: 1 cubic foot = 0.02832 m³, 1 pound = 0.454 kg, 1 gallon = 3.785 L.

NA = Not Applicable, NL = Not Limited, UD = Unclassified Detonable.

- a. For use of control areas, see Section 5003.8.3.
- b. The aggregate quantity in use and storage shall not exceed the quantity listed for storage.
- c. The quantities of alcoholic beverages in retail and wholesale sales occupancies shall not be limited providing the liquids are packaged in individual containers not exceeding 1.3 gallons. In retail and wholesale sales occupancies, the quantities of medicines, foodstuff or consumer products and cosmetics containing not more than 50 percent by volume of water-miscible liquids with the remainder of the solutions not being flammable shall not be limited, provided that such materials are packaged in individual containers not exceeding 1.3 gallons.
- d. Maximum allowable quantities shall be increased 100 percent in buildings equipped throughout with an approved automatic sprinkler system in accordance with Section 903.3.1.1. Where Note e applies, the increase for both notes shall be applied accumulatively.
- e. Maximum allowable quantities shall be increased 100 percent where stored in approved storage cabinets, day boxes, gas cabinets, gas rooms, exhausted enclosures or in listed safety cans in accordance with Section 5003.9.10. Where Note d applies, the increase for both notes shall be applied accumulatively.
- f. Quantities shall not be limited in a building equipped throughout with an approved automatic sprinkler system in accordance with Section 903.3.1.1.
- g. Allowed only in buildings equipped throughout with an approved automatic sprinkler system.
- h. Containing not more than the maximum allowable quantity per control area of Class IA, Class IB or Class IC flammable liquids.
- i. The maximum allowable quantity shall not apply to fuel oil storage complying with Section 603.3.2.
- j. Quantities in parenthesis indicate quantity units in parenthesis at the head of each column.
- k. A maximum quantity of 220 pounds of solid or 22 gallons of liquid Class 3 oxidizers is allowed where such materials are necessary for maintenance purposes, operation or sanitation of equipment where the storage containers and the manner of storage are approved.
- l. Net weight of pyrotechnic composition of the fireworks. Where the net weight of the pyrotechnic composition of the fireworks is not known, 25 percent of the gross weight of the fireworks including packaging shall be used.
- m. For gallons of liquids, divide the amount in pounds by 10 in accordance with Section 5003.1.2.
- n. For storage and display quantities in Group M and storage quantities in Group S occupancies complying with Section 5003.11, see Table 5003.11.1.
- o. Densely-packed baled cotton that complies with the packing requirements of ISO 8115 shall not be included in this material class.
- p. The following shall not be included in determining the maximum allowable quantities:
 1. Liquid or gaseous fuel in fuel tanks on vehicles.
 2. Liquid or gaseous fuel in fuel tanks on motorized equipment operated in accordance with this code.
 3. Gaseous fuels in piping systems and fixed appliances regulated by the International Fuel Gas Code.
 4. Liquid fuels in piping systems and fixed appliances regulated by the International Mechanical Code.
 5. Alcohol-based hand rubs classified as Class I or II liquids in dispensers that are installed in accordance with Sections 5705.5 and 5705.5.1. The location of the alcohol-based hand rub (ABHR) dispensers shall be provided in the construction documents.
- q. Where manufactured, generated or used in such a manner that the concentration and conditions create a fire or explosion hazard based on information prepared in accordance with Section 104.7.2.

TABLE 307.1(1)

MAXIMUM ALLOWABLE QUANTITY PER CONTROL AREA OF HAZARDOUS MATERIALS POSING A PHYSICAL HAZARD^{a, j, m, n, p}

MATERIAL	CLASS	GROUP WHEN THE MAXIMUM ALLOWABLE QUANTITY IS EXCEEDED	STORAGE ^b			USE-CLOSED SYSTEMS ^b			USE-OPEN SYSTEMS ^b	
			Solid pounds (cubic feet)	Liquid gallons (pounds)	Gas (cubic feet at NTP)	Solid pounds (cubic feet)	Liquid gallons (pounds)	Gas (cubic feet at NTP)	Solid pounds (cubic feet)	Liquid gallons (pounds)
Combustible dust	NA	H-2	See Note q	NA	NA	See Note q	NA	NA	See Note q	NA
Combustible fiber ⁱ	Loose	H-3	(100)	NA	NA	(100)	NA	NA	(20)	NA
	Baled ^r		(1,000)			(1,000)			(200)	
Combustible liquid ^{s-1}	I	H-2 or H-3	NA	120 ^{d, e}	NA	NA	120 ^d	NA	NA	30 ^d
	IIA	H-2 or H-3		330 ^{d, e}			330 ^d			80 ^d
	IIB	NA		13,200 ^{n, f}			13,200 ^f			3,300 ^f
Cryogenic flammable	NA	H-2	NA	45 ^d	NA	NA	45 ^d	NA	NA	10 ^d
Cryogenic inert	NA	NA	NA	NA	NL	NA	NA	NL	NA	NA
Cryogenic oxidizing	NA	H-3	NA	45 ^d	NA	NA	45 ^d	NA	NA	10 ^d
Explosives	Division 1.1	H-1	1 ^{n, g}	(1) ^{n, g}	NA	0.25 ^g	(0.25) ^g	NA	0.25 ^g	(0.25) ^g
	Division 1.2	H-1	1 ^{n, g}	(1) ^{n, g}		0.25 ^g	(0.25) ^g		0.25 ^g	(0.25) ^g
	Division 1.3	H-1 or H-2	5 ^{n, g}	(5) ^{n, g}		1 ^g	(1) ^g		1 ^g	(1) ^g
	Division 1.4	H-3	50 ^{n, g}	(50) ^{n, g}		50 ^g	(50) ^g		NA	NA
	Division 1.4G	H-3	125 ^{n, h, i}	NA		NA	NA		NA	NA
	Division 1.5	H-1	1 ^{n, g}	(1) ^{n, g}		0.25 ^g	(0.25) ^g		0.25 ^g	(0.25) ^g
	Division 1.6	H-1	1 ^{n, g}	NA		NA	NA		NA	NA
Flammable gas	Gaseous	H-2	NA	NA	1,000 ^{d, e}	NA	NA	1,000 ^{d, e}	NA	NA
	Liquefied		(150) ^{d, e}	NA	(150) ^{d, e}	NA				
Flammable liquid ^s	IA	H-2 or H-3	NA	30 ^{d, e}	NA	NA	30 ^d	NA	NA	10 ^d
	IB and IC		120 ^{d, e}		120 ^d		30 ^d			
Flammable liquid combination (IA, IB, IC)	NA	H-2 or H-3	NA	120 ^{d, e, h}	NA	NA	120 ^{d, h}	NA	NA	30 ^{d, h}
Flammable solid	NA	H-3	125 ^{d, e}	NA	NA	125 ^d	NA	NA	25 ^d	NA
Inert gas	Gaseous	NA	NA	NA	NL	NA	NA	NL	NA	NA
	Liquefied	NA	NA	NA	NL	NA	NA	NL	NA	NA
Organic peroxide	UD	H-1	1 ^{n, g}	(1) ^{n, g}	NA	0.25 ^g	(0.25) ^g	NA	0.25 ^g	(0.25) ^g
	I	H-2	5 ^{d, e}	(5) ^{d, e}		1 ^d	(1) ^d		1 ^d	(1) ^d
	II	H-3	50 ^{d, e}	(50) ^{d, e}		50 ^d	(50) ^d		10 ^d	(10) ^d
	III	H-3	125 ^{d, e}	(125) ^{d, e}		125 ^d	(125) ^d		25 ^d	(25) ^d
	IV	NA	NL	NL		NL	NL		NL	NL
V	NA	NL	NL		NL	NL		NL	NL	
Oxidizer	4	H-1	1 ^g	(1) ^{n, g}	NA	0.25 ^g	(0.25) ^g	NA	0.25 ^g	(0.25) ^g
	3 ^h	H-2 or H-3	10 ^{d, e}	(10) ^{d, e}		2 ^g	(2) ^g		2 ^g	(2) ^g
	2	H-3	250 ^{d, e}	(250) ^{d, e}		250 ^d	(250) ^d		50 ^d	(50) ^d
	1	NA	4,000 ^{n, f}	(4,000) ^{n, f}		4,000 ^f	(4,000) ^f		1,000 ^f	(1,000) ^f
Oxidizing gas	Gaseous	H-3	NA	NA	1,500 ^{d, e}	NA	NA	1,500 ^{d, e}	NA	NA
	Liquefied		(150) ^{d, e}	NA	(150) ^{d, e}	NA				
Pyrophoric	NA	H-2	4 ^{n, g}	(4) ^{n, g}	50 ^{n, g}	1 ^g	(1) ^g	10 ^{n, g}	0	0
Unstable (reactive)	4	H-1	1 ^{n, g}	(1) ^{n, g}	10 ^{n, g}	0.25 ^g	(0.25) ^g	2 ^{n, g}	0.25 ^g	(0.25) ^g
	3	H-1 or H-2	5 ^{d, e}	(5) ^{d, e}	50 ^{d, e}	1 ^d	(1) ^d	10 ^{n, e}	1 ^d	(1) ^d
	2	H-3	50 ^{d, e}	(50) ^{d, e}	750 ^{d, e}	50 ^d	(50) ^d	750 ^{d, e}	10 ^d	(10) ^d
	1	NA	NL	NL	NL	NL	NL	NL	NL	NL
Water reactive	3	H-2	5 ^{d, e}	(5) ^{d, e}	NA	5 ^d	(5) ^d	NA	1 ^d	(1) ^d
	2	H-3	50 ^{d, e}	(50) ^{d, e}		50 ^d	(50) ^d		10 ^d	(10) ^d
	1	NA	NL	NL		NL	NL		NL	NL

For SI: 1 cubic foot = 0.028 m³, 1 pound = 0.454 kg, 1 gallon = 3.785 L.

NL = Not Limited; NA = Not Applicable; UD = Unclassified Detonable.

- a. For use of control areas, see Section 414.2.
- b. The aggregate quantity in use and storage shall not exceed the quantity listed for storage.
- c. The quantities of alcoholic beverages in retail and wholesale sales occupancies shall not be limited provided the liquids are packaged in individual containers not exceeding 1.3 gallons. In retail and wholesale sales occupancies, the quantities of medicines, foodstuffs or consumer products, and cosmetics containing not more than 50 percent by volume of water-miscible liquids with the remainder of the solutions not being flammable, shall not be limited, provided that such materials are packaged in individual containers not exceeding 1.3 gallons.
- d. Maximum allowable quantities shall be increased 100 percent in buildings equipped throughout with an automatic sprinkler system in accordance with Section 903.3.1.1. Where Note e also applies, the increase for both notes shall be applied accumulatively.
- e. Maximum allowable quantities shall be increased 100 percent when stored in approved storage cabinets, day boxes, gas cabinets, gas rooms or exhausted enclosures or in listed safety cans in accordance with Section 5003.9.10 of the International Fire Code. Where Note d also applies, the increase for both notes shall be applied accumulatively.
- f. Quantities shall not be limited in a building equipped throughout with an automatic sprinkler system in accordance with Section 903.3.1.1.
- g. Allowed only in buildings equipped throughout with an automatic sprinkler system in accordance with Section 903.3.1.1.
- h. Containing not more than the maximum allowable quantity per control area of Class IA, IB or IC flammable liquids.
- i. The maximum allowable quantity shall not apply to fuel oil storage complying with Section 603.3.2 of the International Fire Code.
- j. Quantities in parentheses indicate quantity units in parentheses at the head of each column.
- k. A maximum quantity of 220 pounds of solid or 22 gallons of liquid Class 3 oxidizers is allowed when such materials are necessary for maintenance purposes, operation or sanitation of equipment when the storage containers and the manner of storage are approved.
- l. Net weight of the pyrotechnic composition of the fireworks. Where the net weight of the pyrotechnic composition of the fireworks is not known, 25 percent of the gross weight of the fireworks, including packaging, shall be used.
- m. For gallons of liquids, divide the amount in pounds by 10 in accordance with Section 5003.1.2 of the International Fire Code.
- n. For storage and display quantities in Group M and storage quantities in Group S occupancies complying with Section 414.2.5, see Tables 414.2.5(1) and 414.2.5(2).
- o. Densely packed baled cotton that complies with the packing requirements of ISO 8115 shall not be included in this material class.
- p. The following shall not be included in determining the maximum allowable quantities:
 1. Liquid or gaseous fuel in fuel tanks on vehicles.
 2. Liquid or gaseous fuel in fuel tanks on motorized equipment operated in accordance with the International Fire Code.
 3. Gaseous fuels in piping systems and fixed appliances regulated by the International Fuel Gas Code.
 4. Liquid fuels in piping systems and fixed appliances regulated by the International Mechanical Code.
 5. Alcohol-based hand rubs classified as Class I or II liquids in dispensers that are installed in accordance with Sections 5705.5 and 5705.5.1 of the International Fire Code. The location of the alcohol-based hand rub (ABHR) dispensers shall be provided in the construction documents.
- q. Where manufactured, generated or used in such a manner that the concentration and conditions create a fire or explosion hazard based on information prepared in accordance with Section

Reason:

Footnote d in the 2015 Edition was deleted for the solid storage limit of Division 1.4G explosives based upon action taking place with NFPA 1124. However, there is full scale fire testing that indicates that an automatic sprinkler system designed to Ordinary Hazard Group 2 criteria, as defined in NFPA 13, is capable of controlling a fire involving consumer fireworks. In addition, recent fire tests conducted in a test program managed by FM Global has also demonstrated the ability of an automatic sprinkler system to control a fire involving consumer fireworks.

Cost Impact

The code change proposal will decrease the cost of construction .

The code change proposal will have an impact of decreasing the cost of construction for those applications in which the increased by Footnote d will not require the facility to be considered Group H-3.

Internal ID: 2042

F282-18

IFC: TABLE 5003.1.1(1), 5003.8.3, 5003.8.3.1, 5003.8.3.2, 5306.2; IBC: [F]TABLE 307.1(1), [F] 414.2, [F]414.2.1, [F]414.2.2, [F]427.2

Proponent: John Williams, Chair, representing Healthcare Committee (AHC@iccsafe.org)

2018 International Fire Code

Revise as follows:

TABLE 5003.1.1(1)

MAXIMUM ALLOWABLE QUANTITY PER CONTROL AREA OF HAZARDOUS MATERIALS POSING A PHYSICAL HAZARD^a, j, m, n, p

MATERIAL	CLASS	GROUP WHEN THE MAXIMUM ALLOWABLE QUANTITY IS EXCEEDED	STORAGE ^b			USE-CLOSED SYSTEMS ^b			USE-OPEN SYSTEMS ^b	
			Solid pounds(cubic feet)	Liquid gallons (pounds)	Gas (cubic feet at NTP)	Solid pounds(cubic feet)	Liquid gallons (pounds)	Gas (cubic feet at NTP)	Solid pounds(cubic feet)	Liquid gallons (pounds)
Combustible dust	NA	H-2	See Note q	NA	NA	See Note q	NA	NA	See Note q	NA
Combustible fibers ^q	Loose	H-3	(100)	NA	NA	(100)	NA	NA	(20)	NA
	Baled ^r		(1,000)			(1,000)			(200)	
Combustible liquid ^r	II	H-2 or H-3	NA	120 ^{d, e}	NA	NA	120 ^d	NA	NA	30 ^d
	IIA	H-2 or H-3		330 ^{d, e}			330 ^d			80 ^d
	IIIB	NA		13,200 ^{d, e, f}			13,200 ^d			3,300 ^d
Cryogenic Flammable	NA	H-2	NA	45 ^d	NA	NA	45 ^d	NA	NA	10 ^d
Cryogenic Inert	NA	NA	NA	NA	NL	NA	NA	NL	NA	NA
Cryogenic Oxidizing	NA	H-3	NA	45 ^d	NA	NA	45 ^d	NA	NA	10 ^d
Explosives	Division 1.1	H-1	1 ^{a, g}	(1) ^{a, g}	NA	0.25 ^g	(0.25) ^g	NA	0.25 ^g	(0.25) ^g
	Division 1.2	H-1	1 ^{a, g}	(1) ^{a, g}		0.25 ^g	(0.25) ^g		0.25 ^g	(0.25) ^g
	Division 1.3	H-1 or H-2	5 ^{a, g}	(5) ^{a, g}		1 ^g	(1) ^g		1 ^g	(1) ^g
	Division 1.4	H-3	50 ^{a, g}	(50) ^{a, g}		50 ^g	(50) ^g		NA	NA
	Division 1.4G	H-3	125 ^{a, i}	NA		NA	NA		NA	NA
	Division 1.5	H-1	1 ^{a, g}	(1) ^{a, g}		0.25 ^g	(0.25) ^g		0.25 ^g	(0.25) ^g
	Division 1.6	H-1	1 ^{a, g}	NA		NA	NA		NA	NA
Flammable Gas	Gaseous	H-2	NA	NA	1,000 ^{d, n}	NA	NA	1,000 ^{d, n}	NA	NA
	Liquefied			(150) ^{d, n}			(150) ^{d, e}		NA	
Flammable liquid ^r	IA	H-2 or H-3	NA	30 ^{d, e}	NA	NA	30 ^d	NA	NA	10 ^d
	IB and IC			120 ^{d, e}			120 ^d			30 ^d
Flammable liquid, combination (IA, IB, IC)	NA	H-2 or H-3	NA	120 ^{d, e, h}	NA	NA	120 ^{d, h}	NA	NA	30 ^{d, h}
Flammable solid	NA	H-3	125 ^{d, e}	NA	NA	125 ^d	NA	NA	25 ^d	NA
Inert Gas	Gaseous	NA	NA	NA	NL	NA	NA	NL	NA	NA
	Liquefied	NA	NA	NA	NL	NA	NA	NL	NA	NA
Organic peroxide	UD	H-1	1 ^{a, g}	(1) ^{a, g}	NA	0.25 ^g	(0.25) ^g	NA	0.25 ^g	(0.25) ^g
	I	H-2	5 ^{d, e}	(5) ^{d, e}		1 ^g	(1) ^g		1 ^g	(1) ^g
	II	H-3	50 ^{d, e}	(50) ^{d, e}		50 ^g	(50) ^g		10 ^g	(10) ^g
	III	H-3	125 ^{d, e}	(125) ^{d, e}		125 ^d	(125) ^d		25 ^d	(25) ^d
	IV	NA	NL	NL		NL	NL		NL	NL
	V	NA	NL	NL		NL	NL		NL	NL
Oxidizer	4	H-1	1 ^g	(1) ^{a, g}	NA	0.25 ^g	(0.25) ^g	NA	0.25 ^g	(0.25) ^g
	3 ^g	H-2 or H-3	10 ^{d, e}	(10) ^{d, e}		2 ^d	(2) ^g		2 ^d	(2) ^g
	2	H-3	250 ^{d, e}	(250) ^{d, e}		250 ^d	(250) ^d		50 ^d	(50) ^d
	1	NA	4,000 ^{d, f}	(4,000) ^{d, f}		4,000 ^d	(4,000) ^d		1,000 ^d	(1,000) ^d
Oxidizing gas ^l	Gaseous	H-3	NA	NA	1,500 ^{d, n}	NA	NA	1,500 ^{d, n}	NA	NA
	Liquefied			(150) ^{d, n}			(150) ^{d, n}		NA	
Pyrophoric	NA	H-2	4 ^{a, g}	(4) ^{a, g}	50 ^{a, g}	1 ^g	(1) ^g	10 ^{a, g}	0	0
Unstable (reactive)	4	H-1	1 ^{a, g}	(1) ^{a, g}	10 ^{a, g}	0.25 ^g	(0.25) ^g	2 ^{a, g}	0.25 ^g	(0.25) ^g
	3	H-1 or H-2	5 ^{d, e}	(5) ^{d, e}	50 ^{a, e}	1 ^g	(1) ^g	10 ^{d, e}	1 ^d	(1) ^d
	2	H-3	50 ^{d, e}	(50) ^{d, e}	750 ^{d, e}	50 ^d	(50) ^d	750 ^{d, e}	10 ^d	(10) ^d
	1	NA	NL	NL	NL	NL	NL	NL	NL	NL
Water reactive	3	H-2	5 ^{d, e}	(5) ^{d, e}	NA	5 ^d	(5) ^d	NA	1 ^d	(1) ^d
	2	H-3	50 ^{d, e}	(50) ^{d, e}		50 ^d	(50) ^d		10 ^d	(10) ^d
	1	NA	NL	NL		NL	NL		NL	NL

For SI: 1 cubic foot = 0.02832 m³, 1 pound = 0.454 kg, 1 gallon = 3.785 L.

NA = Not Applicable, NL = Not Limited, UD = Unclassified Detonable.

- a. For use of control areas, see Section 5003.8.3.
- b. The aggregate quantity in use and storage shall not exceed the quantity listed for storage.
- c. The quantities of alcoholic beverages in retail and wholesale sales occupancies shall not be limited providing the liquids are packaged in individual containers not exceeding 1.3 gallons. In retail and wholesale sales occupancies, the quantities of medicines, foodstuff or consumer products and cosmetics containing not more than 50 percent by volume of water-miscible liquids with the remainder of the solutions not being flammable shall not be limited, provided that such materials are packaged in individual containers not exceeding 1.3 gallons.
- d. Maximum allowable quantities shall be increased 100 percent in buildings equipped throughout with an approved automatic sprinkler system in accordance with Section 903.3.1.1. Where Note e applies, the increase for both notes shall be applied accumulatively.
- e. Maximum allowable quantities shall be increased 100 percent where stored in approved storage cabinets, day boxes, gas cabinets, gas rooms, exhausted enclosures or in listed safety cans in accordance with Section 5003.9.10. Where Note d applies, the increase for both notes shall be applied accumulatively.
- f. Quantities shall not be limited in a building equipped throughout with an approved automatic sprinkler system in accordance with Section 903.3.1.1.
- g. Allowed only in buildings equipped throughout with an approved automatic sprinkler system.
- h. Containing not more than the maximum allowable quantity per control area of Class IA, Class IB or Class IC flammable liquids.
- i. The maximum allowable quantity shall not apply to fuel oil storage complying with Section 603.3.2.
- j. Quantities in parenthesis indicate quantity units in parenthesis at the head of each column.
- k. A maximum quantity of 220 pounds of solid or 22 gallons of liquid Class 3 oxidizers is allowed where such materials are necessary for maintenance purposes, operation or sanitation of equipment where the storage containers and the manner of storage are approved.
- l. Net weight of pyrotechnic composition of the fireworks. Where the net weight of the pyrotechnic composition of the fireworks is not known, 25 percent of the gross weight of the fireworks including packaging shall be used.
- m. For gallons of liquids, divide the amount in pounds by 10 in accordance with Section 5003.1.2.
- n. For storage and display quantities in Group M and storage quantities in Group S occupancies complying with Section 5003.11, see Table 5003.11.1.
- o. Densely-packed baled cotton that complies with the packing requirements of ISO 8115 shall not be included in this material class.
- p. The following shall not be included in determining the maximum allowable quantities:
 1. Liquid or gaseous fuel in fuel tanks on vehicles.
 2. Liquid or gaseous fuel in fuel tanks on motorized equipment operated in accordance with this code.
 3. Gaseous fuels in piping systems and fixed appliances regulated by the International Fuel Gas Code.
 4. Liquid fuels in piping systems and fixed appliances regulated by the International Mechanical Code.
 5. Alcohol-based hand rubs classified as Class I or II liquids in dispensers that are installed in accordance with Sections 5705.5 and 5705.5.1. The location of the alcohol-based hand rub (ABHR) dispensers shall be provided in the construction documents.
- q. Where manufactured, generated or used in such a manner that the concentration and conditions create a fire or explosion hazard based on information prepared in accordance with Section 104.7.2.
- r. In Group I-2 occupancies and ambulatory care facilities, medical gas and oxidizing gases used for patient care in portable containers and in immediate use shall not contribute to the maximum allowable quantities of hazardous materials in a building and shall be in accordance with the

exception to Section 5003.8.3.2..

5003.8.3 Control areas. *Control areas* shall comply with Sections 5003.8.3.1 through 5003.8.3.5.3.

Exception: Higher education laboratories in accordance with Chapter 38 of this code and Section 428 of the International Building Code.

Add new text as follows:

5003.8.3.1 Construction requirements. *Control areas* shall be separated from each other by *fire barriers* constructed in accordance with Section 707 of the International Building Code or *horizontal assemblies* constructed in accordance with Section 711 of the International Building Code, or both.

Exception: In Group I-2 occupancies, control areas shall be permitted to be separated by smoke barriers complying with Section 709 of the IBC.

Revise as follows:

5003.8.3.2 Percentage of maximum allowable quantities. The percentage of maximum allowable quantities of hazardous materials per *control area* allowed at each story within a building shall be in accordance with Table 5003.8.3.2.

Exception: In Group I-2 occupancies and ambulatory care facilities, a maximum aggregate quantity of 3,000 cubic feet of oxidizing medical gases in portable containers each with a capacity of 25 cubic feet (708 L) or less shall be permitted in a single smoke compartment. The maximum number of control areas per story shall not exceed the number of smoke compartments provided per story.

5306.2 Interior supply location. Medical gases shall be located in areas dedicated to the storage of such gases without other storage or uses. Where containers of medical gases in quantities greater than the permit amount are located inside buildings, they shall be in a 1-hour exterior room, a 1-hour interior room or a gas cabinet in accordance with Section 5306.2.1, 5306.2.2 or 5306.2.3, respectively. Rooms or areas where medical gases are stored or used in quantities exceeding the *maximum allowable quantity per control area* as set forth in Section 5003.1 shall be in accordance with the International Building Code for high-hazard Group H occupancies.

Exception: Medical gases in portable containers complying with Section 5003.8.3 shall not be required to be stored within dedicated storage rooms.

2018 International Building Code

TABLE 307.1(1)

MAXIMUM ALLOWABLE QUANTITY PER CONTROL AREA OF HAZARDOUS MATERIALS POSING A PHYSICAL HAZARDa, j, m, n, p

MATERIAL	CLASS	GROUP WHEN THE MAXIMUM ALLOWABLE QUANTITY IS EXCEEDED	STORAGE ^b			USE-CLOSED SYSTEMS ^b			USE-OPEN SYSTEMS ^b	
			Solid pounds (cubic feet)	Liquid gallons (pounds)	Gas (cubic feet at NTP)	Solid pounds (cubic feet)	Liquid gallons (pounds)	Gas (cubic feet at NTP)	Solid pounds (cubic feet)	Liquid gallons (pounds)
Combustible dust	NA	H-2	See Note q	NA	NA	See Note q	NA	NA	See Note q	NA
Combustible fiber ^q	Loose	H-3	(100)	NA	NA	(100)	NA	NA	(20)	NA
	Baled ^r		(1,000)			(1,000)			(200)	
Combustible liquid ^{c, i}	I	H-2 or H-3	NA	120 ^{d, e}	NA	NA	120 ^d	NA	NA	30 ^g
	IIA	H-2 or H-3		330 ^{e, h}	330 ^d		80 ^g			
	IIIB	NA		13,200 ^{e, f}	13,200 ^d		3,300 ^g			
Cryogenic flammable	NA	H-2	NA	45 ^d	NA	NA	45 ^d	NA	NA	10 ^d
Cryogenic inert	NA	NA	NA	NA	NL	NA	NA	NL	NA	NA
Cryogenic oxidizing	NA	H-3	NA	45 ^d	NA	NA	45 ^d	NA	NA	10 ^d
Explosives	Division 1.1	H-1	1 ^{e, g}	(1) ^{e, g}	NA	0.25 ^g	(0.25) ^g	NA	0.25 ^g	(0.25) ^g
	Division 1.2	H-1	1 ^{e, g}	(1) ^{e, g}		0.25 ^g	(0.25) ^g		0.25 ^g	(0.25) ^g
	Division 1.3	H-1 or H-2	5 ^{e, g}	(5) ^{e, g}		1 ^g	(1) ^g		1 ^g	(1) ^g
	Division 1.4	H-3	50 ^{e, g}	(50) ^{e, g}		50 ^g	(50) ^g		NA	NA
	Division 1.4G	H-3	125 ^{e, i}	NA		NA	NA		NA	NA
	Division 1.5	H-1	1 ^{e, g}	(1) ^{e, g}		0.25 ^g	(0.25) ^g		0.25 ^g	(0.25) ^g
	Division 1.6	H-1	1 ^{e, g}	NA		NA	NA		NA	NA
Flammable gas	Gaseous	H-2	NA	NA	1,000 ^{d, e}	NA	NA	1,000 ^{d, e}	NA	NA
	Liquefied			(150) ^{d, e}	NA		(150) ^{d, e}	NA		
Flammable liquid ^c	A	H-2 or H-3	NA	30 ^{d, e}	NA	NA	30 ^d	NA	NA	10 ^d
	B and C			120 ^{d, e}	120 ^d		30 ^g			
Flammable liquid, combination (A, B, C)	NA	H-2 or H-3	NA	120 ^{d, e, h}	NA	NA	120 ^{d, h}	NA	NA	30 ^{e, h}
Flammable solid	NA	H-3	125 ^{d, e}	NA	NA	125 ^d	NA	NA	25 ^d	NA
Inert gas	Gaseous	NA	NA	NA	NL	NA	NA	NL	NA	NA
	Liquefied	NA	NA	NA	NL	NA	NA	NL	NA	NA
Organic peroxide	UD	H-1	1 ^{e, g}	(1) ^{e, g}	NA	0.25 ^g	(0.25) ^g	NA	0.25 ^g	(0.25) ^g
	I	H-2	5 ^{d, e}	(5) ^{d, e}		1 ^d	(1) ^d		1 ^d	(1) ^d
	II	H-3	50 ^{d, e}	(50) ^{d, e}		50 ^d	(50) ^d		10 ^d	(10) ^d
	III	H-3	125 ^{d, e}	(125) ^{d, e}		125 ^d	(125) ^d		25 ^d	(25) ^d
	IV	NA	NL	NL		NL	NL		NL	NL
	V	NA	NL	NL		NL	NL		NL	NL
Oxidizer	4	H-1	1 ^g	(1) ^{e, g}	NA	0.25 ^g	(0.25) ^g	NA	0.25 ^g	(0.25) ^g
	3 ^h	H-2 or H-3	10 ^{d, e}	(10) ^{d, e}		2 ^d	(2) ^d		2 ^d	(2) ^d
	2	H-3	250 ^{d, e}	(250) ^{d, e}		250 ^d	(250) ^d		50 ^d	(50) ^d
	1	NA	4,000 ^{e, f}	(4,000) ^{e, f}		4,000 ^f	(4,000) ^f		1,000 ^f	(1,000) ^f
Oxidizing gas	Gaseous	H-3	NA	NA	1,500 ^{d, e}	NA	NA	1,500 ^{d, e}	NA	NA
	Liquefied			(150) ^{d, e}	NA		(150) ^{d, e}	NA		
Pyrophoric	NA	H-2	4 ^{e, g}	(4) ^{e, g}	50 ^{e, g}	1 ^g	(1) ^g	10 ^{e, g}	0	0
Unstable (reactive)	4	H-1	1 ^{e, g}	(1) ^{e, g}	10 ^{e, g}	0.25 ^g	(0.25) ^g	2 ^{e, g}	0.25 ^g	(0.25) ^g
	3	H-1 or H-2	5 ^{d, e}	(5) ^{d, e}	50 ^{d, e}	1 ^d	(1) ^d	10 ^{d, e}	1 ^d	(1) ^d
	2	H-3	50 ^{d, e}	(50) ^{d, e}	750 ^{d, e}	50 ^d	(50) ^d	750 ^{d, e}	10 ^d	(10) ^d
	1	NA	NL	NL	NA	NL	NL	NL	NL	NL
Water reactive	3	H-2	5 ^{d, e}	(5) ^{d, e}	NA	5 ^d	(5) ^d	NA	1 ^d	(1) ^d
	2	H-3	50 ^{d, e}	(50) ^{d, e}		50 ^d	(50) ^d		10 ^d	(10) ^d
	1	NA	NL	NL		NL	NL		NL	NL

For SI: 1 cubic foot = 0.028 m³, 1 pound = 0.454 kg, 1 gallon = 3.785 L.

NL = Not Limited; NA = Not Applicable; UD = Unclassified Detonable.

- a. For use of control areas, see Section 414.2.
- b. The aggregate quantity in use and storage shall not exceed the quantity listed for storage.
- c. The quantities of alcoholic beverages in retail and wholesale sales occupancies shall not be limited provided the liquids are packaged in individual containers not exceeding 1.3 gallons. In retail and wholesale sales occupancies, the quantities of medicines, foodstuffs or consumer products, and cosmetics containing not more than 50 percent by volume of water-miscible liquids with the remainder of the solutions not being flammable, shall not be limited, provided that such materials are packaged in individual containers not exceeding 1.3 gallons.
- d. Maximum allowable quantities shall be increased 100 percent in buildings equipped throughout with an automatic sprinkler system in accordance with Section 903.3.1.1. Where Note e also applies, the increase for both notes shall be applied accumulatively.
- e. Maximum allowable quantities shall be increased 100 percent when stored in approved storage cabinets, day boxes, gas cabinets, gas rooms or exhausted enclosures or in listed safety cans in accordance with Section 5003.9.10 of the International Fire Code. Where Note d also applies, the increase for both notes shall be applied accumulatively.
- f. Quantities shall not be limited in a building equipped throughout with an automatic sprinkler system in accordance with Section 903.3.1.1.
- g. Allowed only in buildings equipped throughout with an automatic sprinkler system in accordance with Section 903.3.1.1.
- h. Containing not more than the maximum allowable quantity per control area of Class IA, IB or IC flammable liquids.
- i. The maximum allowable quantity shall not apply to fuel oil storage complying with Section 603.3.2 of the International Fire Code.
- j. Quantities in parentheses indicate quantity units in parentheses at the head of each column.
- k. A maximum quantity of 220 pounds of solid or 22 gallons of liquid Class 3 oxidizers is allowed when such materials are necessary for maintenance purposes, operation or sanitation of equipment when the storage containers and the manner of storage are approved.
- l. Net weight of the pyrotechnic composition of the fireworks. Where the net weight of the pyrotechnic composition of the fireworks is not known, 25 percent of the gross weight of the fireworks, including packaging, shall be used.
- m. For gallons of liquids, divide the amount in pounds by 10 in accordance with Section 5003.1.2 of the International Fire Code.
- n. For storage and display quantities in Group M and storage quantities in Group S occupancies complying with Section 414.2.5, see Tables 414.2.5(1) and 414.2.5(2).
- o. Densely packed baled cotton that complies with the packing requirements of ISO 8115 shall not be included in this material class.
- p. The following shall not be included in determining the maximum allowable quantities:
 1. Liquid or gaseous fuel in fuel tanks on vehicles.
 2. Liquid or gaseous fuel in fuel tanks on motorized equipment operated in accordance with the International Fire Code.
 3. Gaseous fuels in piping systems and fixed appliances regulated by the International Fuel Gas Code.
 4. Liquid fuels in piping systems and fixed appliances regulated by the International Mechanical Code.
 5. Alcohol-based hand rubs classified as Class I or II liquids in dispensers that are installed in accordance with Sections 5705.5 and 5705.5.1 of the International Fire Code. The location of the alcohol-based hand rub (ABHR) dispensers shall be provided in the construction documents.
- q. Where manufactured, generated or used in such a manner that the concentration and conditions create a fire or explosion hazard based on information prepared in accordance with Section

414.1.3.

- r. In Group I-2 occupancies and ambulatory care facilities, medical gas and oxidizing gases used for patient care in portable containers and in immediate use shall not contribute to the maximum allowable quantities of hazardous materials in a building and shall be in accordance with the exception to Section 414.2.2.

[F] 414.2 Control areas. *Control areas* shall comply with Sections 414.2.1 through 414.2.5 and the International Fire Code.

Exception: Higher education laboratories in accordance with Section 428 and Chapter 38 of the International Fire Code.

[F] 414.2.1 Construction requirements. *Control areas* shall be separated from each other by *fire barriers* constructed in accordance with Section 707 or *horizontal assemblies* constructed in accordance with Section 711, or both.

Exception: In Group I-2 occupancies, control areas shall be permitted to be separated by smoke barriers complying with Section 709.

[F] 414.2.2 Percentage of maximum allowable quantities. The percentage of maximum allowable quantities of hazardous materials per *control area* permitted at each floor level within a building shall be in accordance with Table 414.2.2.

Exception: In Group I-2 occupancies and ambulatory care facilities, a maximum aggregate quantity of 3,000 cubic feet of oxidizing medical gases in portable containers each with a capacity of 25 cubic feet (708 L) or less shall be permitted in a single smoke compartment. The maximum number of control areas per story shall not exceed the number of smoke compartments provided per story.

[F] 427.2 Interior supply location. Medical gases shall be located in areas dedicated to the storage of such gases without other storage or uses. Where containers of medical gases in quantities greater than the permitted amount are located inside the buildings, they shall be located in a 1-hour exterior room, 1-hour interior room or a gas cabinet in accordance with Section 427.2.1, 427.2.2 or 427.2.3, respectively. Rooms or areas where medical gases are stored or used in quantities exceeding the maximum allowable quantity per control area as set forth in Tables 307.1(1) and 307.1(2) shall be in accordance with Group H occupancies.

Exception: Medical gases in portable containers complying with Section 414.2 shall not be required to be stored within dedicated storage rooms.

Reason:

The purpose of this code change is to align high-rise requirements for storage of gases in high-rise I-2 occupancies. The current Fire Code requires higher-levels to conform to H-occupancy requirements. This code seeks to align protection requirements to what have been maintained in high-rise hospitals, rather than change the MAQ's.

Compressed oxidizing gases, including oxygen and nitrous oxide, are required for patient treatment in nearly all acute care hospitals and most outpatient surgical centers for a variety of purposes. While such health care facilities have bulk oxygen systems that include piped medical gas systems within the facilities, portable cylinders are necessary to supply specific types of patient care equipment and for mobile use of patients. The gas supply must be transportable. In addition, cylinders allow the gas pressure to be regulated whereas medical gas systems are at a constant pressure.

The IFC limits hazardous materials outside of Group H occupancies to quantities that have been deemed acceptable for the primary occupancy. Where the maximum allowable quantity (MAQ) is exceeded, the area is required to be protected as a Group H high hazard occupancy. In the case of oxidizing gases, the area would be classified as a Group H-3 occupancy.

One of the most common types of compressed gas cylinders in health care facilities is the E-size cylinder. A full E-size cylinder contains approximately 23-25 cubic feet of compressed oxygen. Thus, a maximum of 12 E-size cylinders would be permitted on the 11th floor of a building. Assuming that a reserve cylinder is provided, two cylinders per patient, compressed oxygen could be provided for up to six patients. For the vast majority of high-rise hospitals and medical centers, the limitation of 12 E-size cylinders on the upper stories would severely limit patient care. Many existing health care facilities may be in non-compliance with IFC requirements.

The 2012 edition of NFPA 99 has been adopted and is enforced by the Centers for Medicaid and Medicare Services (CMS), The Joint Commission (TJC) among accreditation agencies, and State Agencies. Thus, NFPA 99 is a mandatory code with respect to Federal regulations. Health care facilities are required to comply with the provisions of NFPA 99 and are subject to severe penalties for non-compliance. A link to NFPA 99 already exists in the IFC through the provisions for medical gas system installations. Health care facilities are surveyed for compliance with NFPA codes and standards at least once every three years and often more frequently to ensure continued compliance.

Unlike the IFC and IBC , NFPA 99 does not prescribe limitations based on the location of the compressed medical oxidizing gases in the building. The NFPA 99 limits for storage of medical oxidizing gases are based on the following thresholds:

300 cubic feet or less;

More than 300 cubic feet but not more than 3,000 cubic feet;

More than 3,000 cubic feet.

The proposed code changes seek to revise the IFC and IBC to be more consistent with the federally mandated code requirements while maintaining the control area concept thereby permitting a vast number of health care facilities to comply with the IFC and IBC.

CONTROL AREAS

Add a footnote r to IFC Table 5003.1.1(1) (IBC Table 307.1(1)) to be applied to the Oxidizing gas cell in the MATERIAL column.

Add an exception to Section 5003.8.3.1 (IBC 414.2.1) -This will permit existing requirements for smoke compartment construction to serve as barriers for control areas

Add an exception to Section 5003.8.3.2 (IBC 414.2.2) - 25 cubic feet is roughly the capacity of an E cylinder, which is the largest portable cylinder on the market and the most common cylinder found in hospitals. Larger cylinders would be expected to be in a med gas room on a lower floor. This will permit up to 3,000 cubic feet of oxygen, or 120 E size cylinders, per smoke compartment regardless of the location of the smoke compartment in the building.

This proposal is submitted by the ICC Committee on Healthcare (CHC). The CHC was established by the ICC Board to evaluate and assess contemporary code issues relating to healthcare facilities. This is a joint effort between ICC and the American Society for Healthcare Engineering (ASHE), a subsidiary of the American Hospital Association, to eliminate duplication and conflicts in healthcare regulation. In 2017 the CHC held 2 open meetings and numerous conference calls, which included members of the committees as well as any interested parties, to discuss and debate the proposed changes. Information on the CHC, including: meeting agendas; minutes; reports; resource documents; presentations; and all other materials developed in conjunction with the CHC effort can be downloaded from the CHC website at: <https://www.iccsafe.org/codes-tech-support/cs/icc-committee-on-healthcare/>.

Cost Impact

The code change proposal will decrease the cost of construction .

This will limit the number of rooms in a hospital that will have to be considered hazardous thus reducing the cost of construction.

Internal ID: 706

F283-18

IFC: TABLE 5003.1.1(3)

Proponent: Lynne Kilpatrick, Sunnyvale Department of Public Safety, representing California Fire Chiefs Association
(lkilpatrick@sunnyvale.ca.gov)

2018 International Fire Code

Revise as follows:

TABLE 5003.1.1(3)

MAXIMUM ALLOWABLE QUANTITY PER CONTROL AREA OF HAZARDOUS MATERIALS POSING A PHYSICAL HAZARD IN AN OUTDOOR CONTROL AREAa, b, c, d

MATERIAL	CLASS	STORAGE ^b			USE-CLOSED SYSTEMS ^b			USE-OPEN SYSTEMS ^b		
		Solid pounds (cubic feet)	Liquid gallons (pounds) ^d	Gas cubic feet at NTP	Solid pounds (cubic feet)	Liquid gallons (pounds) ^d	Gas cubic feet at NTP	Solid pounds (cubic feet)	Liquid gallons (pounds) ^d	
Flammable gas	Gaseous Liquefied	Not Applicable	Not Applicable (300)	3,000/Not Applicable	Not Applicable	Not Applicable (150)	1,500/Not Applicable	Not Applicable	Not Applicable	
Flammable solid	Not Applicable	500	Not Applicable	Not Applicable	250	Not Applicable	Not Applicable	50	Not Applicable	
Inert Gas/Cryogenic inert	Gaseous/Liquefied/Not Applicable	Not Applicable/Not Applicable/Not Applicable	Not Applicable/Not Applicable/Not Applicable	Not Limited/Not Limited/Not Limited	Not Applicable/Not Applicable/Not Applicable	Not Applicable/Not Applicable/Not Applicable	Not Limited/Not Limited/Not Limited	Not Applicable/Not Applicable/Not Applicable	Not Applicable/Not Applicable/Not Applicable	
Organic peroxide	Unclassified/Detonable	1	(1)	Not Applicable	0.25	(0.25)	Not Applicable	0.25	(0.25)	
Organic peroxide	III/IV	20/200/500/1,000/Not Limited	(20)/(200)/(500) (1,000)/Not Limited	Not Applicable	10/100/250/500/Not Limited	(10)/(100)/(250) (500)/Not Limited	Not Applicable	220/500/1,000/Not Limited	(2)/(20)/(50) (100)/Not Limited	
Oxidizer	4321	240/1,000/Not Limited	(2)/(40)/(1,000)/Not Limited	Not Applicable	120/500/Not Limited	(1)/(20)/(500)/Not Limited	Not Applicable	0.25/4/100/Not Limited	(0.25)/(4)/(100)/Not Limited	
Oxidizing gas	Gaseous/Liquefied	Not Applicable	Not Applicable (500)	6,000/Not Applicable	Not Applicable	Not Applicable (300)	1,500/Not Applicable	Not Applicable	Not Applicable	
Pyrophoric materials	Not Applicable	8	(8)	100	4	(4)	10	0	0	
Unstable (reactive)	4321	220/200/Not Limited	(2)/(20)/(200)/Not Limited	20/200/1,000/1,500	110/100/Not Limited	(1)/(10)/(100)/Not Limited	21/025/Not Limited	0.25/1/10/Not Limited	(0.25)/(1)/(10)/Not Limited	
Water reactive	321	20/200/Not Limited	(20)/(200)/Not Limited	Not Applicable	10/100/Not Limited	(10)/(100)/Not Limited	Not Applicable	1/10/Not Limited	(1)/(10)/Not Limited	

For SI: 1 pound = 0.454 kg, 1 gallon = 3.785 L, 1 cubic foot = 0.02832 m³.

- a. For gallons of liquids, divide the amount in pounds by 10 in accordance with Section 5003.1.2.
- b. The aggregate quantities in storage and use shall not exceed the quantity listed for storage.
- c. The aggregate quantity of nonflammable solid and nonflammable or noncombustible liquid hazardous materials allowed in outdoor storage per single property under the same ownership or control used for retail or wholesale sales is allowed to exceed the maximum allowable quantity per control area where such storage is in accordance with Section 5003.11.
- d. Quantities in parentheses indicate quantity units in parentheses at the head of each column.

Reason:

Class IV organic peroxides are "formulations that burn in the same manner as ordinary combustibles and that pose minimal reactivity hazard". As a result, Table 5003.1.1(1) does not limit the quantity of Class IV organic peroxide liquids and solids stored or used indoors. However, currently Table 5003.1.1(2) limits Class IV organic peroxides when stored or used outdoors making outdoor storage and use more restrictive than indoor storage and use and making Class IV organic peroxides the only class of hazardous materials with this distinction. Research of historical code changes related to organic peroxides revealed that this discrepancy has been in place since the first edition of the IFC and no justification for the discrepancy could be located. This proposal is to align the Class IV organic peroxide outdoor MAQ with the indoor MAQ by revising the outdoor MAQ to "not limited" for storage, use closed and use open.

Cost Impact

The code change proposal will not increase or decrease the cost of construction .

The code change increases the quantity of Class IV organic peroxides allowed outdoors before additional controls are required to be implemented.

Internal ID: 1279

F284-18

IFC: 5003.2.2.1

Proponent: Kevin Scott, representing KH Scott & Associates LLC (khscottassoc@gmail.com)

2018 International Fire Code

Revise as follows:

5003.2.2.1 Design and construction. Piping, tubing, valves, fittings and related components used for hazardous materials shall be in accordance with the following:

1. Piping, tubing, valves, fittings and related components shall be designed and fabricated from materials that are compatible with the material to be contained and shall be of adequate strength and durability to withstand the pressure, structural and seismic stress and exposure to which they are subject.
2. Piping and tubing shall be identified in accordance with ASME A13.1 to indicate the material conveyed.
3. Manual valves or automatic remotely activated fail-safe emergency shutoff valves shall be installed on supply piping and tubing and provided with *ready access* at the following locations:
 - 3.1. The point of use.
 - 3.2. The tank, cylinder or bulk source.
4. Manual emergency shutoff valves and controls for remotely activated emergency shutoff valves shall be ~~identified and the location shall have access~~ clearly visible and indicated by means of a ~~sign, provided with ready access and identified in an approved manner.~~
5. Backflow prevention or check valves shall be provided where the backflow of hazardous materials could create a hazardous condition or cause the unauthorized discharge of hazardous materials.

Exceptions:

1. Piping for inlet connections designed to prevent backflow.
2. Piping for pressure relief devices.

Reason:

First, this proposal revises Item 4 by reorganizing the list of requirements into a simpler format. This removes the jumbled and confusing wording.

Secondly, this proposal removes the requirement for a sign. The first part of Item 4 requires that the valves are "identified", and then it says they must have a "sign." This is redundant and unnecessary.

The goal is that the valves are identified and accessible. The first part of the sentence addresses visibility and ready access to the valves; the second sentence now addresses identification of the valves. Identification is specified as needing to meet approval of the fire code official.

Cost Impact

The code change proposal will not increase or decrease the cost of construction .

This simply clarifies application of the section.

Internal ID: 2157

F285-18

IFC: 5003.2.2.2

Proponent: Mark Fasel, representing Viega LLC (mark.fasel@viega.us)

2018 International Fire Code

Revise as follows:

5003.2.2.2 Additional regulations for supply piping for health-hazard materials. Supply piping and tubing for gases and liquids having a health-hazard ranking of 3 or 4 in accordance with NFPA 704 shall be in accordance with ASME B31.3 and the following:

1. Piping and tubing utilized for the transmission of highly toxic, toxic or highly volatile *corrosive* liquids and gases shall have welded, threaded, press-connected or flanged connections throughout except for connections located within a ventilated enclosure if the material is a gas, or an *approved* method of drainage or containment is provided for connections if the material is a liquid.
2. Piping and tubing shall not be located within *corridors*, within any portion of a *means of egress* required to be enclosed in fire-resistance-rated construction or in concealed spaces in areas not classified as Group H occupancies.

Exception: Piping and tubing within the space defined by the walls of *corridors* and the floor or roof above or in concealed spaces above other occupancies where installed in accordance with Section 415.11.6.4 of the International Building Code for Group H-5 occupancies.

Reason:

Because "Press-Connect" type connections are not specifically identified in section 5003.2.2.2(1), they are in some instances not recognized for use even though they are tested to, and in compliance to ASME B31.3.

The description of ASME B31.3 is as follows:

ASME B31.3 contains requirements for piping typically found in petroleum refineries; chemical, pharmaceutical, textile, paper, semiconductor, and cryogenic plants; and related processing plants and terminals. It covers materials and components, design fabrication, assembly, erection, examination, inspection and testing of piping.

ASME B31.3 applies to piping for all fluids including:

- (1) raw, intermediate, and finished chemicals;
- (2) petroleum products;
- (3) gas, steam, air and water;
- (4) fluidized solids;
- (5) refrigerants; and
- (6) cryogenic fluids

Bibliography:

ASME B31.3

American Society of Mechanical Engineers

Published 2016

Section 300.1 Scope

www.asme.org

Cost Impact

The code change proposal will not increase or decrease the cost of construction .

There are no costs associated with this proposal.

Internal ID: 829

F286-18

IFC: 5003.7.4 (New)

Proponent: John Williams, Chair, representing Healthcare Committee (AHC@iccsafe.org)

2018 International Fire Code

Add new text as follows:

5003.7.4 Respiratory therapy. In Group I-2 and ambulatory care facilities, within areas with respiratory therapy services, sources of ignition shall be regulated in accordance with NFPA 99.

Reason:

Due to the high potential for fire risk to patients receiving respiratory therapy services the need to restrict the use of sources of ignition, such as smoking materials, open flames, sparking toys, and non-medical appliances with hot surfaces or sparking mechanisms, is necessary to provide appropriate safety to these patients (K925).

This proposal is submitted by the ICC Committee on Healthcare (CHC). The CHC was established by the ICC Board to evaluate and assess contemporary code issues relating to healthcare facilities. This is a joint effort between ICC and the American Society for Healthcare Engineering (ASHE), a subsidiary of the American Hospital Association, to eliminate duplication and conflicts in healthcare regulation. In 2017 the CHC held 2 open meetings and numerous conference calls, which included members of the committees as well as any interested parties, to discuss and debate the proposed changes. Information on the CHC, including: meeting agendas; minutes; reports; resource documents; presentations; and all other materials developed in conjunction with the CHC effort can be downloaded from the CHC website at: <https://www.iccsafe.org/codes-tech-support/cs/icc-committee-on-healthcare/>.

Cost Impact

The code change proposal will not increase or decrease the cost of construction .

This change is an operational change regarding the restriction of sources of ignition and will not increase the cost of construction on the healthcare industry.

Internal ID: 697

F287-18

IFC: TABLE 5003.8.2; IBC: [F] TABLE 415.6.2

Proponent: Patrick McLaughlin, representing Semiconductor Industry Association (pmclaugma@aol.com)

2018 International Fire Code

Revise as follows:

**TABLE 5003.8.2
DETACHED BUILDING REQUIRED**

A DETACHED BUILDING IS REQUIRED WHERE THE QUANTITY OF MATERIAL EXCEEDS THAT LISTED HEREIN			
Material	Class	Solids and liquids (tons)^{a, b}	Gases (cubic feet)^{a, b}
Explosives	Division 1.1 Division 1.2 Division 1.3 Division 1.4 Division 1.4 ^c Division 1.5 Division 1.6	Maximum Allowable Quantity Maximum Allowable Quantity Maximum Allowable Quantity Maximum Allowable Quantity Maximum Allowable Quantity Maximum Allowable Quantity Maximum Allowable Quantity	Not Applicable
Oxidizers	Class 4	Maximum Allowable Quantity	Maximum Allowable Quantity
Unstable (reactives) detonable	Class 3 or 4	Maximum Allowable Quantity	Maximum Allowable Quantity
Oxidizer, liquids and solids	Class 3 Class 2	1,200 2,000	Not Applicable
Organic peroxides	Detonable Class I Class II Class III	Maximum Allowable Quantity Maximum Allowable Quantity Maximum Allowable Quantity 2550	Not Applicable
Unstable (reactives) nondetonable	Class 3 Class 2	125	2,000 10,000
Water reactives	Class 3 Class 2	125	Not Applicable
Pyrophoric gases ^d	Not Applicable	Not Applicable	2,000

For SI: 1 pound = 0.454 kg, 1 cubic foot = 0.02832 m³, 1 ton = 2000 lbs. = 907.2 kg.

- a. For materials that are detonable, the distance to other buildings or lot lines shall be in accordance with Section 415.6 of the International Building Code or Chapter 56 based on the trinitrotoluene (TNT) equivalence of the material, whichever is greater.
- b. "Maximum Allowable Quantity" means the maximum allowable quantity per control area set forth in Table 5003.1.1(1).
- c. Limited to Division 1.4 materials and articles, including articles packaged for shipment, that are not regulated as an explosive under Bureau of Alcohol, Tobacco, Firearms and Explosives regulations, or unpackaged articles used in process operations that do not propagate a detonation or deflagration between articles, providing the net explosive weight of individual articles does not exceed 1 pound.
- d. Detached buildings are not required, for gases in gas rooms that support H-5 fabrication facilities where the gas room is separated from other areas by a fire barrier with a fire resistance rating of not less than 2 hours and the gas is located in a gas cabinet that is internally sprinklered, equipped with continuous leak detection, automatic shutdown and is not manifolded upstream of pressure controls. Additionally, the gas supply is limited to cylinders that do not exceed 125 lb (57 kg) water capacity in accordance with 49 CFR 173.192 for Hazard Zone A toxic gases.

2018 International Building Code

Revise as follows:

**[F] TABLE 415.6.2
DETACHED BUILDING REQUIRED**

A DETACHED BUILDING IS REQUIRED WHERE THE QUANTITY OF MATERIAL EXCEEDS THAT LISTED HEREIN			
Material	Class	Solids and Liquids (tons)^{a, b}	Gases (cubic feet)^{a, b}
Explosives	Division 1.1	Maximum Allowable Quantity	Not Applicable
	Division 1.2	Maximum Allowable Quantity	
	Division 1.3	Maximum Allowable Quantity	
	Division 1.4	Maximum Allowable Quantity	
	Division 1.4 ^c	1	
	Division 1.5	Maximum Allowable Quantity	
	Division 1.6	Maximum Allowable Quantity	
Oxidizers	Class 4	Maximum Allowable Quantity	Maximum Allowable Quantity
Unstable (reactives) detonable	Class 3 or 4	Maximum Allowable Quantity	Maximum Allowable Quantity
Oxidizer, liquids and solids	Class 3	1,200	Not Applicable
	Class 2	2,000	Not Applicable
Organic peroxides	Detonable	Maximum Allowable Quantity	Not Applicable
	Class I	Maximum Allowable Quantity	Not Applicable
	Class II	25	Not Applicable
	Class III	50	Not Applicable
Unstable (reactives) nondetonable	Class 3	1	2,000
	Class 2	25	10,000
Water reactives	Class 3	1	Not Applicable
	Class 2	25	Not Applicable
Pyrophoric gases ^d	Not Applicable	Not Applicable	2,000

For SI: 1 ton = 906 kg, 1 cubic foot = 0.02832 m³, 1 pound = 0.454 kg.

- a. For materials that are detonable, the distance to other buildings or lot lines shall be in accordance with Section 415.6 of this code or Chapter 56 of the International Fire Code based on trinitrotoluene (TNT) equivalence of the material, whichever is greater.
- b. "Maximum Allowable Quantity" means the maximum allowable quantity per control area set forth in Table 307.1(1).
- c. Limited to Division 1.4 materials and articles, including articles packaged for shipment, that are not regulated as an explosive under Bureau of Alcohol, Tobacco, Firearms and Explosives (BATF) regulations or unpackaged articles used in process operations that do not propagate a detonation or deflagration between articles, provided that the net explosive weight of individual articles does not exceed 1 pound.
- d. Detached buildings are not required, for gases in gas rooms that support H-5 fabrication facilities where the gas room is separated from other areas by a fire barrier with a fire resistance rating of not less than 2 hours and the gas is located in a gas cabinet that is internally sprinklered, equipped with continuous leak detection, automatic shutdown and is not manifolded upstream of pressure controls. Additionally, the gas supply is limited to cylinders that do not exceed 125 lb (57 kg) water capacity in accordance with 49 CFR 173.192 for Hazard Zone A toxic gases.

Reason:

□Introduction:

This code change proposal to the IFC Table 5003.8.2 (IBC Table 415.6.2) removes the detached building requirement for pyrophoric gases, when the gas is located in gas rooms supporting H5 occupancies and in internally sprinklered gas cabinets, with leak detection and automatic shutdown. The following analysis supports the code change by explaining why a detached building is not justified nor will the removal of the requirement have any adverse impact. If the code change is approved, pyrophoric gases will still be required to comply with all other applicable requirements including, to be in gas rooms separated from the FAB by two hour construction. Also, the gas room will be located on an exterior wall, and where two exits are required, one shall be directly to the exterior. The gas room and cabinets will have a continuous gas detection system with a local alarm that will automatically shut off the gas at the source, and transmit an alarm to a local emergency control station.

Background/History:

A 2000 cu ft. code provision developed due to the fire service concern with traditional pyrophoric rooms, and the use of silane in open manifold systems with the potential for multiple cylinder/cascade releases.

It was initially published in the 1988 Edition of the UFC as documented in Larry Fluer's NFPA Research Foundation report issued in December 2008. One of the most common materials was silane where not only the pyrophoric nature of the material is a concern, but also the potential for accumulation and vapor cloud detonation when latent ignition occurs. There were incidents in the supply chain as well at use sites which highlighted these issues, and as a result, silane served as the exemplar "pyrophoric gas" material. It was also recognized that other gases such as phosphine and diborane had pyrophoric properties and were added to the consideration. Silane was used as the index "pyrophoric" gas to determine appropriate limits and controls (similar to the approach used for other categories, e.g. chlorine was the index gas used for toxics, etc.). There was a concern expressed by the fire service, and industry alike, that there should be a quantity limit of some sort following the concepts established for the use of detached building threshold limits in the fire and building codes, while at the same time recognizing that the gas is not inherently an explosive material. The most common silane container size used at the time was the 5000 gram cylinder, containing a nominal 132 cu ft of gas. An aggregate quantity of 2000 cu ft represented approximately 15 cylinders of this size. Larger cylinders of silane including bulk delivery were also recognized as an evolving means of delivery, and a conscious decision was made to step back from counting cylinders, and to use a quantity limit in cubic feet as the threshold for requiring detached storage with the recognition that the larger the quantity, the bigger the problem in the event of an occurrence. This decision paralleled the approach taken with the rest of the items in the detached building table.

As the silicon wafer sizes increased and the fabrication industry expanded, the use of silane increased dramatically. Many users were connecting multiple cylinders onto common manifolds to provide continuous supply to the FAB. There were numerous silane incidents (fires and explosions) at gas supplier and user sites. At that time there was limited research on silane safety. Since 1988 there has been extensive testing of silane and silane systems. Key studies:

Dr. L. Britton, Union Carbide - 1990's; D. F. Tamini, FM Global - 1995-1996; CGA, Socorro, NM - 1996; Prof. J. Chen, NFKST -2006-2016; CGA, Las Cruces, NM - 2010-2011

In addition, recognizing the unique hazards (pyrophoric with non-reliable ignition) nature of silane, the Compressed Gas

Association developed and published ANSI/CGA G-13 Standard for Storage and Handling of Silane and Silane Mixtures in 1992. A key conclusion was that many of the multiple cylinder incidents were caused by the cylinder Pressure Relief Devices leaking prematurely. The fire then caused adjacent cylinder PRD's to activate. With an exception for silane filled to the maximum density, PRD's are no longer used in the US.

Technical Justification:

The move to bulk silane and outdoor silane pads, and the application of ANSI/CGA G-13 Silane Safety Standard recommended controls to mitigate the unique hazards/properties of silane use, and the risks and hazards of other pyrophoric gases used in the semiconductor industry differ greatly from the assumptions applied to the requirements developed in the 1980's. 21st century H2 occupancy gas rooms are required by IFC to segregate HPM gases (including pyrophoric gases) in gas cabinets which limit the consequences of a gas leak. In addition, the hazard mitigation controls typically included:

Exhaust with capture velocity of 200 FPM or higher to prevent pyrophoric concentrations and release out of the enclosure

Continuously welded gas delivery lines

Leak detection and automatic shutdown

Excess flow protection

Restricted flow orifices

Automated and interlocked leak integrity testing of connections prior to introduction of HPM gas after a cylinder change

Gas Cabinet fire sprinklers

Gas rooms separated from the FAB by one hour construction when less than 300 sq ft or two hour construction when 300 sq ft or greater

Gas rooms shall be located on an exterior wall, and where two exits are required, one shall be directly to the exterior

The additional requirement to restrict manifolding of pyrophorics upstream of pressure monitoring devices, was included to prevent a large release from a single loss of containment scenario due to multiple gas cabinets connected in a manifold and used as one system. In addition, NFPA 55, Standard for Compressed Gas and Cryogenic Fluids is also concurrently assessing this technical issue. This proposal aligns with what the NFPA Task Force is presenting at the Second Draft Meeting in the spring of 2018.

Conclusion:

Approved gas cabinets, in gas rooms, have proven to be effective in isolating the gas hazards, even pyrophoric in over 25 years of service. The proposed code change will provide a safe system for control of pyrophoric gases in gas rooms serving H5 occupancies.

Attachment:

Cost Impact

The code change proposal will decrease the cost of construction .

The cost of construction will be decreased because a detached building will not be constructed. Besides removing the cost of the property and building construction, the cost of piping the gas to the fabrication facility will be eliminated.

Internal ID: 612

F288-18

IFC: 5003.8.3.3; IBC: [F]414.2.3

Proponent: Kevin Scott, representing KH Scott & Associates LLC (khscottassoc@gmail.com)

2018 International Fire Code

Revise as follows:

5003.8.3.3 Number. The maximum number of *control areas* per floor within a building shall be in accordance with Table 5003.8.3.2. For the purposes of determining the number of control areas within a building, each portion of a building separated by one or more fire walls complying with Section 706 of the International Building Code shall be considered a separate building.

2018 International Building Code

Revise as follows:

[F] 414.2.3 Number. The maximum number of *control areas* within a building shall be in accordance with Table 414.2.2. For the purposes of determining the number of control areas within a building, each portion of a building separated by one or more fire walls complying with Section 706 shall be considered a separate building.

Reason:

The language regarding application of fire wall requirements changed in the 2018 IBC as a result of G130-15. Where previously, the code stated that fire walls created separate buildings, it now states that fire walls only create separate buildings when applying height, area and type of construction requirements.

This resulted in an unintended consequence in its application to control areas. The number of control areas in a building has previously been counted separately on each side of a fire wall. Based on the 2018 IBC change, quantities in these control areas now must be aggregated which has the potential to place many facilities out of compliance. This proposal states the for control area purposed, fire walls will continue to be assumed to create separate building and will allow that application of the control area requirements to continue.

The end result, is that a single-story building can have up to 4 control areas then be divided by a fire wall and up to another 4 control areas. This occurs often in strip malls. See the figure below.

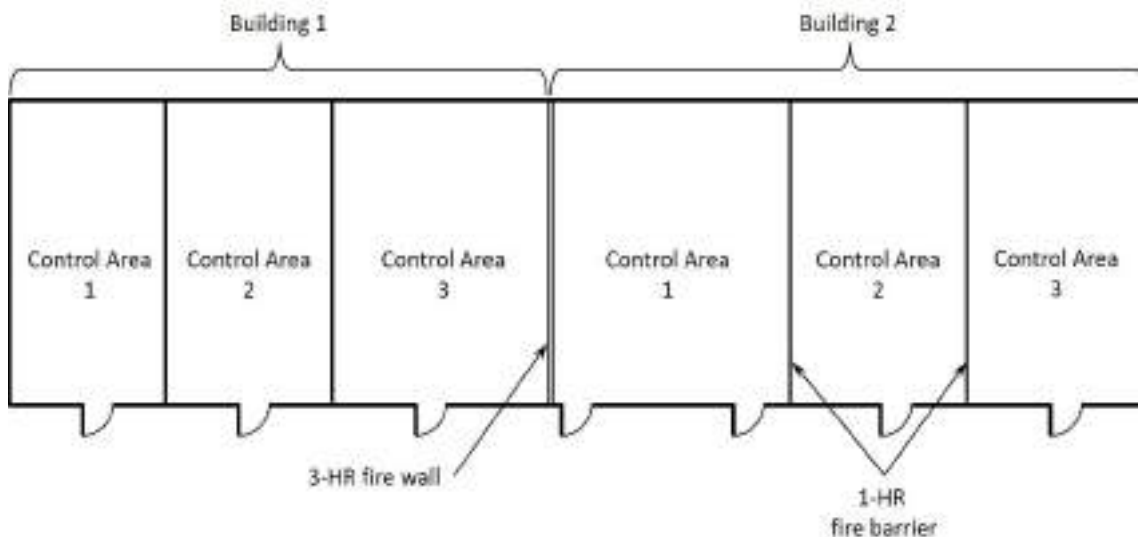

Cost Impact

The code change proposal will decrease the cost of construction .

This will reduce the cost of construction, since a fire wall can be used to increase the number of control areas, rather than constructing a Group H occupancy.

Internal ID: 2148

F289-18

IFC: TABLE 5003.11.1 (IBC: [F] TABLE 414.2.5(1))

Proponent: Michael O'Brian, Chair, representing FCAC (fcac@iccsafe.org)

2018 International Fire Code

Revise as follows:

TABLE 5003.11.1

MAXIMUM ALLOWABLE QUANTITY PER INDOOR AND OUTDOOR CONTROL AREA IN GROUP M AND S OCCUPANCIES—NONFLAMMABLE SOLIDS, NONFLAMMABLE AND NONCOMBUSTIBLE LIQUIDS^{d, e, f}

CONDITION		MAXIMUM ALLOWABLE QUANTITY PER CONTROL AREA	
Material ^a	Class	Solids (pounds)	Liquids (gallons)
A. HEALTH-HAZARD MATERIALS—NONFLAMMABLE AND NONCOMBUSTIBLE SOLIDS AND LIQUIDS			
1. Corrosives ^{b, c}	Not Applicable	9,750	975
2. Highly Toxics	Not Applicable	20 ^{b, c}	2 ^{b, c}
3. Toxics ^{b, c}	Not Applicable	1,000 ^k	100
B. PHYSICAL-HAZARD MATERIALS—NONFLAMMABLE AND NONCOMBUSTIBLE SOLIDS AND LIQUIDS			
1. Oxidizers ^{b, c}	4	Not Allowed	Not Allowed
	3	1,350 ^g	135
	2	2,250 ^h	225
	1	18,000 ^{i, j}	1,800 ^{i, j}
2. Unstable (Reactives) ^{b, c}	4	Not Allowed	Not Allowed
	3	550	55
	2	1,150	115
	1	Not Limited	Not Limited
3. Water Reactives	3 ^{b, c}	550	55
	2 ^{b, c}	1,150	115
	1	Not Limited	Not Limited

For SI: 1 pound = 0.454 kg, 1 gallon = 3.785 L, 1 cubic foot = 0.02832 m³.

- a. Hazard categories are as specified in Section 5001.2.2.
- b. Maximum allowable quantities shall be increased 100 percent in buildings equipped throughout with an *approved* automatic sprinkler system in accordance with Section 903.3.1.1. Where Note c applies, the increase for both notes shall be applied accumulatively.
- c. Maximum allowable quantities shall be increased 100 percent where stored in approved storage cabinets in accordance with Section 5003.8. Where Note b applies, the increase for both notes shall be applied accumulatively.
- d. See Table 5003.8.3.2 for design and number of control areas.
- e. Maximum allowable quantities for other hazardous material categories shall be in accordance with Section 5003.1.
- f. Maximum allowable quantities shall be increased 100 percent in outdoor control areas.
- g. Maximum allowable quantities shall be increased to 2,250 pounds where individual packages are in the original sealed containers from the manufacturer or packager and do not exceed 10 pounds each.
- h. Maximum allowable quantities shall be increased to 4,500 pounds where individual packages are in the original sealed containers from the manufacturer or packager and do not exceed 10 pounds each.
- i. Quantities are unlimited where protected by an automatic sprinkler system.
- j. Quantities are unlimited in an outdoor control area.
- k. Maximum allowable quantity of consumer products shall be increased to 10,000 pounds where individual packages are in the original sealed containers from the manufacturer and the toxic classification is exclusively based on the LC₅₀ threshold and no other hazardous materials classifications apply.

2018 International Building Code

[F] TABLE 414.2.5(1)

MAXIMUM ALLOWABLE QUANTITY PER INDOOR AND OUTDOOR CONTROL AREA IN GROUP M AND S OCCUPANCIES NONFLAMMABLE SOLIDS AND NONFLAMMABLE AND NONCOMBUSTIBLE LIQUIDS^{d, e, f}

CONDITION		MAXIMUM ALLOWABLE QUANTITY PER CONTROL AREA	
Material ^a	Class	Solids pounds	Liquids gallons
A. Health-hazard materials—nonflammable and noncombustible solids and liquids			
1. Corrosives ^{b, c}	Not Applicable	9,750	975
2. Highly toxics	Not Applicable	20 ^{b, c}	2 ^{b, c}
3. Toxics ^{b, c}	Not Applicable	1,000 ^k	100
B. Physical-hazard materials—nonflammable and noncombustible solids and liquids			
1. Oxidizers ^{b, c}	4	Not Allowed	Not Allowed
	3	1,350 ^g	115
	2	2,250 ^h	225
	1	18,000 ^{i, j}	1,800 ^{i, j}
2. Unstable (reactives) ^{b, c}	4	Not Allowed	Not Allowed
	3	550	55
	2	1,150	115
	1	Not Limited	Not Limited
3. Water reactives	3 ^{b, c}	550	55
	2 ^{b, c}	1,150	115
	1	Not Limited	Not Limited

For SI: 1 pound = 0.454 kg, 1 gallon = 3.785 L.

- a. Hazard categories are as specified in the International Fire Code.
- b. Maximum allowable quantities shall be increased 100 percent in buildings that are sprinklered in accordance with Section 903.3.1.1. Where Note c also applies, the increase for both notes shall be applied accumulatively.
- c. Maximum allowable quantities shall be increased 100 percent where stored in approved storage cabinets, in accordance with the International Fire Code. Where Note b also applies, the increase for both notes shall be applied accumulatively.
- d. See Table 414.2.2 for design and number of control areas.
- e. Allowable quantities for other hazardous material categories shall be in accordance with Section 307.
- f. Maximum quantities shall be increased 100 percent in outdoor control areas.
- g. Maximum amounts shall be increased to 2,250 pounds where individual packages are in the original sealed containers from the manufacturer or packager and do not exceed 10 pounds each.
- h. Maximum amounts shall be increased to 4,500 pounds where individual packages are in the original sealed containers from the manufacturer or packager and do not exceed 10 pounds each.
- i. The permitted quantities shall not be limited in a building equipped throughout with an automatic sprinkler system in accordance with Section 903.3.1.1.
- j. Quantities are unlimited in an outdoor control area.
- k. Maximum allowable quantity of consumer products shall be increased to 10,000 pounds where individual packages are in the original sealed containers from the manufacturer and the toxic classification is exclusively based on the LC₅₀ threshold and no other hazardous materials classifications apply.

Reason:

Small businesses often move into warehouse/office suites in light industrial or business complexes without conducting any construction or other activity that would require a review by the fire department. These businesses are often discovered through the fire department's business inspection program. During a walk-thru an inspector would not see anything of significance, but may notice the presence of chemicals and would ask for a hazardous materials inventory, for most businesses this would not garner undue concern. But for some businesses this hazardous materials inventory would trigger a hazardous occupancy review that could have a negative impact on the long term health of the business.

As home ownership in the US increased the small business sector serving homeowners, and the related small service companies, has increased the number of smaller wholesale/distribution centers serving this group. A specific example is lawn care companies. The small wholesale centers serving this group of businesses can be the most affected by a fire department's review of hazardous materials. Many of the lawn chemicals present are classified as toxic based on the LC₅₀ threshold. The total amount of toxics present exceed the maximum allowable quantities thus reclassifying the space as a Group H-4 occupancy. The requirements generated by this classification cause a business significant hardship as the types of buildings occupied typically do not have fire suppression systems, rated construction or any other typical H-occupancy requirements.

The cost of complying with the code is normally not considered a reason to not follow their requirements. If a review of the actual risk is conducted, the H-occupancy requirements can be onerous and more than should be necessary.

While these small distribution centers exceed the maximum allowable quantities the chemicals present are normally in unopened original packaging from the manufacturer. They arrive on pallets wrapped in plastic. The warehouse manager will unwrap the pallets and redistribute the unopened packages to other pallets, creating a loaded pallet to be delivered to a customer. None of the packages are opened. There is no mixing or repackaging occurring, just redistributing to outbound pallets. Even if a spill were to occur, a minimal number of packages (or pounds) would be involved. Most likely the spill would be far under the maximum allowable quantity amount. Spills involving solids, typically in pellet form, do not present a significant inhalation risk.

Further, when evaluating the risk presented by solids in this situation, the reliance of the LC₅₀ threshold itself needs be taken into account.

The International Fire Code has established a definition for toxic materials based on acute toxicity values (oral, dermal and inhalation). For the purpose of this discussion, we are interested in the classification of materials based on the product's acute inhalation toxicity (LC₅₀). The International Fire Code relies on the LC₅₀ of a material for determining a

substances acute inhalation toxicity. However, there seems to be multiple voices in the scientific community that believe the LC₅₀ should not be used as a standalone metric for determining the toxicity of a substance.

This revision is partially based on the artificial nature of the LC₅₀ threshold measurement itself. The process necessary to prepare the sample for the testing does not simulate the expected normal conditions within a typical retail or wholesale building. The solids are required to be highly processed; using high heat and pressure along with mechanical grinding, to create particles sufficiently small enough to be infused deeply within the lungs of the test animals.

The particles (dusts or mists) are then fed into a test chamber or through a face mask to the test specimen. When these procedures are used for the test, they do not represent a real world condition. These procedures create an artificial environment that meet the conditions of the LC₅₀ testing protocol and it would be unlikely that these conditions would exist in a natural environment.

Chemicals in a solid form, including granules and pellets are generally too large to become airborne. Some of the product may be broken down during packaging and handling and create particles fine enough to create an airborne dust, but the situation under consideration is storage and it should be considered whether this potential airborne dust would contain respirable particles. Respirable particulates are generally considered particles with a mean diameter of less than 10 micrometers (PM10).

It would appear that this simulation would be unlikely, as particles in this size range are typically generated through mechanical means such as grinding, sawing, and sanding, or through continuous processes that break down the material such as conveying or mixing for long periods of time. With no use-open or repackaging process present, the PM10 fraction of dust from these products, as stored in a warehouse, likely represents a very small fraction of the entire particle size distribution. Given that the solid products are packaged in relatively small, individual packages, the mass emissions from an accidental spill would be small and the respirable fraction of dust would represent a small portion of the total dust.

Based on an analysis of the actual risk presented by storage in these occupancies an increase in the maximum allowable quantity for Group M and S occupancies is being proposed that addresses the current business model without incurring any additional significant risk.

This proposal is submitted by the ICC Fire Code Action Committee (FCAC). The FCAC was established by the ICC Board of Directors to pursue opportunities to improve and enhance assigned International Codes with regard to fire safety and hazardous materials in new and existing buildings and facilities and the protection of life and property in wildland urban interface areas. In 2017 the Fire-CAC has held 3 open meetings. In addition, there were numerous conference calls, Regional Work Group and Task Group meetings for the current code development cycle, which included members of the committees as well as any interested parties, to discuss and debate the proposed changes. Related documentation and reports are posted on the FCAC website at: <https://www.iccsafe.org/codes-tech-support/cs/fire-code-action-committee-fcac/>

Cost Impact

The code change proposal will not increase or decrease the cost of construction .

The cost impact would be non-existent, except to the extent that a business would benefit from not incurring additional costs. This allows an increase in materials which will reduce compliance cost. This would simply not currently not be permitted in Group M occupancies.

Internal ID: 353

F290-18

IFC: 5003.12, 5004.14 (New), 5005.3.3, 5005.4.3

Proponent: Robert Davidson, Davidson Code Concepts, LLC, representing Self (rjd@davidsoncodeconcepts.com)

2018 International Fire Code

Revise as follows:

5003.12 Outdoor control areas. Outdoor control areas for hazardous materials ~~in amounts not exceeding the maximum allowable quantity per outdoor control area~~ shall be in accordance with the following general requirements:

1. Outdoor control areas shall be kept free from weeds, debris and common combustible materials not necessary to the storage. The area surrounding an outdoor control area shall be kept clear of such materials for not less than 15 feet (4572 mm).
2. Outdoor control areas shall be located not closer than 20 feet (6096 mm) from a public street, public alley, public way or *lot line* that can be built on.

Exceptions:

1. For solid and liquid hazardous materials, a 2-hour fire-resistance-rated wall without openings extending not less than 30 inches (762 mm) above and to the sides of the storage area shall be allowed in lieu of such distance.
2. For compressed gas hazardous materials, unless otherwise specified, the minimum required distances shall not apply where *fire barriers* without openings or penetrations having a minimum *fire-resistance rating* of 2 hours interrupt the line of sight between the storage and the exposure. The configuration of the *fire barrier* shall be designed to allow natural ventilation to prevent the accumulation of hazardous gas concentrations.
3. Where a property exceeds 10,000 square feet (929 m²), a group of two outdoor control areas is allowed where *approved* and where each control area is separated by a minimum distance of 50 feet (15 240 mm).
4. Where a property exceeds 35,000 square feet (3252 m²), additional groups of outdoor control areas are allowed where *approved* and where each group is separated by a minimum distance of 300 feet (91 440 mm).

Add new text as follows:

5004.14 Outdoor storage location. Outdoor storage areas for hazardous materials shall be located as required by Section 5003.12 except where material specific requirements, including requirements in referenced standards, are provided in other chapters of this code.

Revise as follows:

5005.3.3 ~~Location.~~ Outdoor location.. Outdoor dispensing and use areas for hazardous materials shall be located as required by Section 5003.12 except where material specific requirements, including requirements in referenced standards, are provided in other chapters of this code. ~~for outdoor storage in accordance with Section 5004.~~

5005.4.3 ~~Location.~~ Outdoor location.. Outdoor-handling areas for hazardous materials shall be located as required by Section 5003.12 except where material specific requirements, including requirements in referenced standards, are provided in other chapters of this code. ~~for outdoor storage in accordance with Section 5004.~~

Reason:

The intent of this proposal is to provide correlation between Sections 5003, 5004 and 5005 as it applies to outdoor storage of hazardous materials.

Upon review of the requirements Section 5003, both quantities not exceeding the MAQs and quantities exceeding the MAQs are required to comply with all of Section 5003 General Requirements. As structured, when applying the IFC any specific requirement would take precedence over a general requirement, but the general requirements are the starting point.

When you review Section 5003.12 for Outdoor control areas you find that it is limited to "...amounts not exceeding the maximum allowable quantity per outdoor control area...". This is in conflict with Section 5003.1.4 which requires amounts

exceeding the MAQs to comply with the entire chapter. This wouldn't be a problem if requirements dealing with the location of outdoor storage of hazardous materials was provided for in Sections 5004 and 5005.

When reviewing Section 5004 Storage which provides for the storage of hazardous materials exceeding the MAQs, though there are some code requirements applicable to outdoor storage, there are no provisions for the location of the outdoor storage.

In reviewing Section 5005 which deals with Use, Dispensing and Handling of hazardous materials in amounts exceeding the MAQs you find Sections 5005.3.3 and 5005.4.3, both of which point you back to Section 5004 for requirements on the location requirements. As identified above, there are no requirements in Section 5004 dealing with the location of the materials.

This proposal addresses this by modifying Section 5003.12 to delete the language referring to amounts not exceeding the MAQ and adding language identifying the provisions as "general requirements".

Then a new section is added to Section 5004 pointing back to Section 5003.12 when there are no location requirements provided for in the chapters that provide requirements specific to a material or an activity using a hazardous material. This recognizes that there can be requirements within those specific chapters for locations of storage or use such as dispensing in Chapter 23, liquid storage of flammable or combustible liquids in Chapter 57 and in the case of flammable gases previous distance tables were removed and replaced with references to standards such as NFPA 2 and NFPA 55 that contain updated location requirements.

Finally Sections 5005.3.3 and 5005.4.3 have been modified to be similar in language to the new Section 5004.14 and to point back to Section 5003.12.

Cost Impact

The code change proposal will not increase or decrease the cost of construction .

As written, there is no intent to impact the cost of construction, however, by adding clarification on this issue cost can be reduced.

Internal ID: 1606

F291-18

IFC: 5004.3

Proponent: John Williams, Washington State Department of Health, representing Washington State Department of Health (john.williams@doh.wa.gov)

2018 International Fire Code

Revise as follows:

5004.3 Ventilation. Indoor storage areas and storage buildings shall be provided with mechanical exhaust ventilation or natural ventilation where natural ventilation can be shown to be acceptable for the materials as stored.

Exception-Exceptions:

1. Storage areas for flammable solids complying with Chapter 59.
2. Storage areas for medical gases complying with Chapter 53.

Reason:

The ventilation requirements for medical gas systems are already appropriately covered by Section 5306 which contains three different options for ventilation. These include prescriptive requirements for natural ventilation, mechanical ventilation and gas supply cabinets. This change points user to the more specific requirements for medical gases.

Cost Impact

The code change proposal will decrease the cost of construction .

The general provisions in this section require a manual exhaust shut-off. This requirement is not present in the three ventilation options contained in Chapter 53, therefore a cost savings.

Internal ID: 1608

F292-18

IFC: 5004.3

Proponent: Sarah Rice, The Preview Group, representing Myself (srice@preview-group.com)

2018 International Fire Code

Revise as follows:

5004.3 Ventilation. Indoor storage areas and storage buildings shall be provided with mechanical exhaust ventilation or natural ventilation where natural ventilation can be shown to be acceptable for the materials as stored.

Exceptions:

1. Storage areas for flammable solids complying with Chapter 59.
2. Where approved by the fire official, the exhaust ventilation system for areas where flammable and combustible liquids are stored in containers shall comply with the International Mechanical Code provided there are no dispensing operations and documentation has been provided.

Reason:

This code change is a follow-up to F359-16. The intent of this code change is to recognize that when there is no dispensing of flammable or combustible liquids, there is not the need for the same robust level of ventilation, and that the ventilation requirements found in the International Mechanical Code (IMC) should govern.

As was correctly brought up by the testifiers during the previous cycle, the authority to accept a different level of ventilation lies with the fire code official, when it can be demonstrated that these conditions are such that the density of flammable vapors does not constitute a hazard.

As outlined in the reason statement for F359-16, the requirement for the special exhaust system found in Section 5004.3.1 has its origins in, and is consistent with, those found in Chapter 9 of NFPA 30 for areas where there IS dispensing of flammable or combustible liquids (see below). This type of operation/process results in fumes being emitted into the atmosphere of the space. But storage without dispensing does not result in the same conditions.

This code change would allow the fire code official to examine those areas where flammable and combustible liquids are ONLY stored (no dispensing or pour-off) and if provided with documentation, they could be ventilated in accordance with the IMC.

The 2015 edition of NFPA 30; Flammable & Combustible Liquids Code, in Chapter 9 Storage of Liquids in Containers – General Requirements, and specifically in Section 9.14 states "Liquid storage areas where dispensing is conducted shall be provided with ventilation that meets the requirements of Section 18.6." With affirmation of this found in NFPA 30 Section 18.6 Ventilation for Dispensing Areas which reads "Liquid Storage areas where dispensing is conducted shall be provided with a gravity system or a continuous mechanical exhaust ventilation system. Mechanical ventilation shall be used if Class I liquids are dispensed within the room." [underlining is for emphasis only]

The proposed language makes it clear that the special exhaust system specified in Section 5004.3.1 would not be required where flammable and/or combustible liquids are ONLY stored, and there is no dispensing being conducted.

Cost Impact

The code change proposal will decrease the cost of construction .

An exhaust ventilation system designed to meet the ventilation rates in the IMC is less costly than one designed in accordance with IFC Section 5004.3.1

Internal ID: 2295

F293-18

IFC: 105.6.1, 907.2.15, 5101.1, 5101.4, 5103.2.3, 5104.1.1, 5104.1.2 (New), 5104.1.3, TABLE 5104.3.2, 5104.7, TABLE 5104.7, 5105.1, TABLE 5105.1, 5106.1, 5106.2.1, TABLE 5106.2.1, 5106.2.2, 5106.3.2, 5106.3.3, TABLE 5106.4, 5106.5.7;

IBC: [F]307.1.1, [F]414.1.2.1, [F]414.2.5.3, [F]907.2.15

Proponent: Patrick McLaughlin, representing Household & Commercial Products Association (formerly CSPA) (pmclaugma@aol.com)

2018 International Fire Code

Revise as follows:

105.6.1 Aerosol products and aerosol cooking spray products and plastic aerosol 3 products. An operational permit is required to manufacture, store or handle an aggregate quantity of Level 2 or Level 3 aerosol products, aerosol cooking spray products or plastic aerosol 3 products in excess of 500 pounds (227 kg) net weight.

907.2.15 Aerosol storage uses. Aerosol product rooms and general-purpose warehouses containing aerosol products, aerosol cooking spray products or plastic aerosol 3 products shall be provided with an *approved* manual fire alarm system where required by this code.

5101.1 Scope. The provisions of this chapter, the International Building Code and NFPA 30B shall apply to the manufacturing, storage and display of aerosol products, aerosol cooking spray products and plastic aerosol 3 products. Manufacturing of aerosol products, aerosol cooking spray products and plastic aerosol 3 products using hazardous materials shall also comply with Chapter 50.

5101.4 Containers. Metal aerosol containers shall be limited to a maximum size of 33.8 fluid ounces (1000 ml). Plastic aerosol containers shall be limited to a maximum 4 fluid ounces (118 ml) except as provided in Section 5104.1.1 and 5104.1.2. Glass aerosol containers shall be limited to a maximum 4 fluid ounces (118 ml).

5103.2.3 Plastic aerosol products. Cartons or outer packaging containing aerosol products in plastic containers greater than 4 fluid ounces (118 ml) shall be clearly marked as follows:
PLASTIC AEROSOL 1 ~~3~~ or X

5104.1.1 Plastic Level aerosol-1 aerosol products. Aerosol products in plastic containers larger than 4 fluid ounces (118 ml), but not to exceed 33.8 fluid ounces (1000 ml), shall be allowed only where in accordance with this section. The commodity classification shall be Class III commodities, as defined in NFPA 13 where any of the following conditions are met:

1. Base product does not have a fire point where tested in accordance with ASTM D92, and nonflammable propellant.
2. Base product does not sustain combustion as tested in accordance with Appendix H, "Method of Testing for Sustained Combustibility," in DOTn 49 CFR Part 173, and nonflammable propellant.
3. Base product contains up to 20 percent by volume (15.8 percent by weight) of ethanol, isopropyl alcohol or a combination thereof in an aqueous mix, and nonflammable propellant.
4. Base product contains 4 percent by weight or less of an emulsified flammable liquefied gas propellant within an aqueous base. The propellant shall remain emulsified for the life of the product. Where such propellant is not permanently emulsified, the propellant shall be nonflammable.

Add new text as follows:

5104.1.2 Plastic aerosol 3 products. Plastic aerosol 3 products shall be defined as those that meet one of the following criteria:

1. Base product does not have a fire point where tested in accordance with ASTM D 92, and there is not more than 10% by weight flammable propellant.
2. Base product does not sustain combustion as tested in accordance with Appendix H, "method of testing for Sustained Combustibility," in DOTn 49 CFR, 173 and there is not more than 10% by weight flammable propellant.
3. Base product contains 50% by volume or less of flammable or combustible, water-miscible alcohols

in an aqueous mix, and there is not more than 10% by weight of flammable propellant.

Revise as follows:

~~5104.1.2~~ ~~5104.1.3~~ Plastic aerosol X products. Plastic aerosol X products are those products, in containers larger than 4 fluid ounces (118 ml), that do not meet the criteria provided in Section 5104.1.1 or 5104.1.2.

**TABLE 5104.3.2
SEGREGATED STORAGE OF LEVEL 2 AND 3 AEROSOL PRODUCTS AND PLASTIC AEROSOL 3 PRODUCTS IN
GENERAL PURPOSE WAREHOUSES**

STORAGE SEPARATION	MAXIMUM SEGREGATED STORAGE AREA ^a		SPRINKLER REQUIREMENTS
	Percentage of building area (percent)	Area limitation (square feet)	
Separation area ^{e, f}	15	20,000	Notes b, c
Chain-link fence enclosure ^d	20	20,000	Notes b, c
1-hour fire-resistance-rated interior walls	20	30,000	Note b
2-hour fire-resistance-rated interior walls	25	40,000	Note b
3-hour fire-resistance-rated interior walls	30	50,000	Note b

For SI: 1 foot = 304.8 mm, 1 square foot = 0.0929 m².

- a. The maximum segregated storage area shall be limited to the smaller of the two areas resulting from the percentage of building area limitation and the area limitation.
- b. Automatic sprinkler system protection in aerosol product storage areas shall comply with NFPA 30B and be approved. Building areas not containing aerosol product storage shall be equipped throughout with an approved automatic sprinkler system in accordance with Section 903.3.1.1.
- c. Automatic sprinkler system protection in aerosol product storage areas shall comply with NFPA 30B and be approved. Sprinkler system protection shall extend a minimum 20 feet beyond the aerosol storage area.
- d. Chain-link fence enclosures shall comply with Section 5104.3.2.1.
- e. A separation area shall be defined as an area extending outward from the periphery of the segregated aerosol product storage area as follows.
 1. The limits of the aerosol product storage shall be clearly marked on the floor.
 2. The separation distance shall be not less than 25 feet and maintained clear of all materials with a commodity classification greater than Class III in accordance with Section 903.3.1.1.
- f. Separation areas shall only be permitted where approved.

5104.7 Storage in Group M occupancies. Storage of Level 2 and 3 aerosol products ~~and~~ aerosol cooking spray products, and plastic aerosol products in occupancies in Group M shall comply with Table 5104.7. Retail display shall comply with Section 5106.

TABLE 5104.7

**MAXIMUM QUANTITIES OF LEVEL 2 AND 3 AEROSOL PRODUCTS AND, AEROSOL COOKING SPRAY PRODUCTS
AND PLASTIC AEROSOL 3 PRODUCTS IN RETAIL STORAGE AREAS**

MAXIMUM NET WEIGHT PER FLOOR (pounds)			
Floor	Nonsegregated storage^{a, b}	Segregated storage	
		Storage cabinets^b	Separated from retail area^c
Basement	Not Permitted	Not Permitted	Not Permitted
Ground	2,500	5,000	Note d
Upper	500	1,000	Note d

For SI: 1 pound = 0.454 kg, 1 square foot = 0.0929 m².

- a. The total aggregate quantity on display and in storage shall not exceed the maximum retail display quantity indicated in Section 5106.3.
- b. Storage quantities indicated are the maximum permitted in any 50,000- square-foot area.
- c. The storage area shall be separated from the retail area with a 1-hour fireresistance-rated assembly.
- d. See Table 5104.3.2.

5105.1 General. The outside storage of Level 2 and 3 aerosol products, and plastic aerosol 3 products including storage in temporary storage trailers, shall be separated from exposures in accordance with Table 5105.1.

TABLE 5105.1
DISTANCE TO EXPOSURES FOR OUTSIDE STORAGE OF LEVEL 2 AND 3 AEROSOL PRODUCTS AND PLASTIC
AEROSOL 3 PRODUCTS

EXPOSURE	MINIMUM DISTANCE FROM AEROSOL STORAGE (feet)^a
Buildings	50
Exit discharge to a public way	50
Lot lines	20
Other outside storage	50
Public alleys, public ways, public streets	20

For SI: ~~1~~1 inch = 25.4 mm, 1 foot = 304.8 mm.

- a. The minimum separation distance indicated is not required where exterior walls having a 2-hour fire-resistance rating without penetrations separate the storage from the exposure. The walls shall extend not less than 30 inches above and to the sides of Level 2 and 3 aerosol products, and plastic aerosol 3 products.

5106.1 General. This section shall apply to the retail display of 500 pounds (227 kg) or more of Level 2 and 3 aerosol products ~~and, aerosol cooking spray products and plastic aerosol 3~~ products.

5106.2.1 Maximum quantities in retail display areas. Aerosol products ~~and, aerosol cooking spray products, and plastic aerosol 3~~ products in retail display areas shall not exceed quantities needed for display and normal merchandising and shall not exceed the quantities in Table 5106.2.1.

**TABLE 5106.2.1
 MAXIMUM QUANTITIES OF LEVEL 2 AND 3 AEROSOL PRODUCTS AND AEROSOL COOKING SPRAY PRODUCTS
 AND PLASTIC AEROSOL 3 PRODUCTS IN RETAIL DISPLAY AREAS**

MAXIMUM NET WEIGHT PER FLOOR (pounds)^b			
Floor	Unprotected^a	Protected inaccordance with Section 5106.2^{a, c}	Protected inaccordance with Section 5106.3^c
Basement	Not Allowed	500	500
Ground	2,500	10,000	10,000
Upper	500	2,000	Not Allowed

For SI: 1 pound = 0.454 kg, 1 square foot = 0.0929 m².

- a. The total quantity shall not exceed 1,000 pounds net weight in any one 100-square-foot retail display area.
- b. Per 25,000-square-foot retail display area.
- c. Minimum Ordinary Hazard Group 2 wet-pipe automatic sprinkler system throughout the retail sales occupancy.

5106.2.2 Aerosol cooking spray product and plastic aerosol 3 product storage and fire protection. The storage and handling of *aerosol cooking spray products* and *plastic aerosol 3 products* shall comply with this chapter and NFPA 30B.

5106.3.2 Automatic sprinkler protection. Aerosol product and plastic aerosol 3 product display and merchandising areas shall be protected by an *automatic sprinkler system* based on the requirements set forth in Tables 6.4.2.7(a) through 6.4.2.7(l) of NFPA 30B and the following:

1. Protection shall be based on the highest level of aerosol product in the array and the packaging method of the storage located more than 6 feet (1829 mm) above the finished floor.
2. Where using the cartoned aerosol products tables of NFPA 30B, uncartoned or display-cut Level 2 and 3 *aerosol products* and *plastic aerosol 3 products* shall not be permitted more than 6 feet (1829 mm) above the finished floor.
3. The design area for Level 2 and 3 *aerosol products* and *plastic aerosol 3 products* shall extend not less than 20 feet (6096 mm) beyond the Level 2 and 3 *aerosol product* and *plastic aerosol 3 product* display and merchandising areas.
4. Where ordinary and high-temperature ceiling sprinkler systems are adjacent to each other, noncombustible draft curtains shall be installed at the interface.

5106.3.3 Separation of Level 2 and 3 aerosol product and plastic aerosol 3 product areas. Separation of Level 2 and 3 aerosol product areas, *plastic aerosol 3 product areas* shall comply with the following:

1. Level 2 and 3 *aerosol product* or *plastic aerosol 3 product* display and merchandising areas shall be separated from each other by not less than 25 feet (7620 mm). See Table 5106.2.1.
2. Level 2 and 3 aerosol product or plastic aerosol 3 product display and merchandising areas shall be separated from flammable and *combustible liquids* storage and display areas by one or a combination of the following:
 - 2.1. Segregating areas from each other by horizontal distance of not less than 25 feet (7620 mm).
 - 2.2. Isolating areas from each other by a noncombustible partition extending not less than 18 inches (457 mm) above the merchandise.
 - 2.3. In accordance with Section 5106.5.
3. Where Item 2.2 is used to separate Level 2 or 3 aerosol *products* or *plastic aerosol 3 products* from flammable or *combustible liquids*, and the aerosol products are located within 25 feet (7620 mm) of flammable or *combustible liquids*, the area below the noncombustible partition shall be liquid tight at the floor to prevent spilled liquids from flowing beneath the aerosol products.

TABLE 5106.4
MAXIMUM STORAGE QUANTITIES FOR STORAGE AREAS ADJACENT TO RETAIL DISPLAY OF LEVEL 2 AND 3
AEROSOL PRODUCTS AND PLASTIC AEROSOL 3 PRODUCTS

MAXIMUM NET WEIGHT PER FLOOR (pounds)			
Floor	Unseparated^{a, b}	Separated	
		Storage Cabinets^b	1-hour Occupancy Separation
Basement	Not Allowed	Not Allowed	Not Allowed
Ground	2,500	5,000	In accordance with Sections 6.4.4.3 and 6.4.4.4 of NFPA 30B
Upper	500	1,000	In accordance with Sections 6.4.4.3 and 6.4.4.4 of NFPA 30B

For SI: 1 pound = 0.454 kg, 1 square foot = 0.0929 m².

- a. The aggregate quantity in storage and retail display shall not exceed the quantity limits for retail display.
- b. In any 50,000-square-foot area.

5106.5.7 Class I, II, III, IV and plastic commodities. Class I, II, III, IV and plastic commodities located adjacent to Level 2 and 3 aerosol products and plastic aerosol 3 products shall be protected in accordance with NFPA 13.

2018 International Building Code

Revise as follows:

[F] 307.1.1 Uses other than Group H. An occupancy that stores, uses or handles hazardous materials as described in one or more of the following items shall not be classified as Group H, but shall be classified as the occupancy that it most nearly resembles.

1. Buildings and structures occupied for the application of flammable finishes, provided that such buildings or areas conform to the requirements of Section 416 and the International Fire Code.
2. Wholesale and retail sales and storage of flammable and combustible liquids in mercantile occupancies conforming to the International Fire Code.
3. Closed piping system containing flammable or combustible liquids or gases utilized for the operation of machinery or equipment.
4. Cleaning establishments that utilize combustible liquid solvents having a flash point of 140°F (60°C) or higher in closed systems employing equipment *listed* by an *approved* testing agency, provided that this occupancy is separated from all other areas of the building by 1-hour *fire barriers* constructed in accordance with Section 707 or 1-hour *horizontal assemblies* constructed in accordance with Section 711, or both.
5. Cleaning establishments that utilize a liquid solvent having a flash point at or above 200°F (93°C).
6. Liquor stores and distributors without bulk storage.
7. Refrigeration systems.
8. The storage or utilization of materials for agricultural purposes on the premises.
9. Stationary storage battery systems installed in accordance with the International Fire Code.
10. Corrosive personal or household products in their original packaging used in retail display.
11. Commonly used corrosive building materials.
12. Buildings and structures occupied for aerosol product storage, aerosol cooking spray products or plastic aerosol 3 products shall be classified as Group S-1, provided that such buildings conform to the requirements of the International Fire Code.
13. Display and storage of nonflammable solid and nonflammable or noncombustible liquid hazardous materials in quantities not exceeding the maximum allowable quantity per *control area* in Group M or S occupancies complying with Section 414.2.5.
14. The storage of black powder, smokeless propellant and small arms primers in Groups M and R-3 and special industrial explosive devices in Groups B, F, M and S, provided such storage conforms to the quantity limits and requirements prescribed in the International Fire Code.
15. Stationary fuel cell power systems installed in accordance with the International Fire Code.
16. Capacitor energy storage systems in accordance with the International Fire Code.
17. Group B higher education laboratory occupancies complying with Section 428 and Chapter 38 of the International Fire Code.

[F] 414.1.2.1 Aerosol products, aerosol cooking spray products, plastic aerosol 3 products. Level 2 and 3 aerosol products, aerosol cooking spray products or plastic aerosol 3 products shall be stored and displayed in accordance with the International Fire Code. See Section 311.2 and the International Fire Code for occupancy group requirements.

[F] 414.2.5.3 Aerosol products, aerosol cooking spray products, plastic aerosol 3 products. The maximum quantity of aerosol products, aerosol cooking spray products or plastic aerosol 3 products in Group M

occupancy retail display areas, storage areas adjacent to retail display areas and retail storage areas shall be in accordance with the International Fire Code.

[F] 907.2.15 Aerosol storage uses. Aerosol product rooms and general-purpose warehouses containing aerosol products or aerosol cooking spray products or plastic aerosol 3 products shall be provided with an *approved* manual fire alarm system where required by the International Fire Code.

Reason:

The Household and Commercial Products Association (formerly CSPA) presented code change proposals, during the last code cycle, adding Plastic Aerosol 1 products to the International Fire Code. The proposals were accepted, but at the time, fire testing and development of automatic sprinkler protection requirements for other plastic aerosol products had not been conducted. Subsequently, a number of formulations in plastic have been studied by HCPA (CSPA), in conjunction with FM Global Research Campus, to determine the hazard level of the various formulations, and to develop a protection plan for this class of aerosol products that include limited amounts of flammable base product and limited amounts of flammable propellant in plastic containers.

Individual container fire tests were conducted to determine the heat of combustion for various formulations, and to observe how they react to fire. The formulation with the most utility and the most difficult fire protection challenge was chosen for full scale fire testing. Those tests have been successfully completed at FM Global Research Campus, and a robust fire protection design is now available to protect these products in storage. The protection design plan is detailed in NFPA 30B Code for the Manufacture and Storage of Aerosol Products under the definition of Plastic Aerosol 3. Plastic Aerosol 2 is reserved in NFPA 30B for formulations that may be developed in the future that can be protected by a less robust fire protection system.

The purpose of this proposal is to allow Plastic Aerosol 3 products, when protected in accordance with the controls that are being added to chapter 51 Aerosols, and the automatic fire sprinkler protection requirements being added to NFPA 30B Code for Manufacturing and Storage of Aerosol Products. The new aerosol products will bring advantages of use and recycling within the aerosol industry.

Cost Impact

The code change proposal will not increase or decrease the cost of construction .

The proposed code change will allow a new product, plastic aerosol 3, to be manufactured and stored if in compliance with the code change. Similar controls already exist for other aerosol products so there is no additional construction costs or cost savings if the aerosol industry chooses to manufacture and store plastic aerosol 3 products in their facilities.

Internal ID: 1166

F294-18

IFC: 5104.2.2

Proponent: Kevin Scott, representing KH Scott & Associates LLC (khscottassoc@gmail.com)

2018 International Fire Code

Revise as follows:

5104.2.2 Aerosol cooking spray products. Storage of aerosol cooking spray products in A, B, E, F, I and R occupancies shall not be more than 1,000 pounds (454 kg) net weight.

Reason:

In Section 5104.2, Level 2 and 3 aerosol products are limited in Groups A, B, E, F, **I** and R occupancies to a maximum of 1,000 pounds. However, Section 5104.2.2 does not include Group I for aerosol cooking spray products. Section 5104.2.2 limits aerosol cooking spray products to 1,000 pounds in all of the same occupancies except for Group I.

Group I present a higher life hazard than the other occupancies. There is no logical reason not to include Group I into the list of occupancies where use of the aerosol cooking spray products are limited.

Cost Impact

The code change proposal will not increase or decrease the cost of construction .

This change does not affect construction and simply places an upper limit on these materials in Group I occupancies.

Internal ID: 2153

F295-18

IFC: 5306.1.1 (New)

Proponent: John Williams, Chair, representing Healthcare Committee (AHC@iccsafe.org)

2018 International Fire Code

Add new text as follows:

5306.1.1 Training. Personnel who handle medical gases and associated equipment and cylinders shall be trained on the use, safe handling and associated hazards.

Reason:

In addition to meeting the previous codes and standards referenced in this section in order to meet federal conditions of participation health care facilities must comply with the training requirements of medical gas systems and associated equipment and cylinders. This change will align the training requirements of medical gas systems and associated equipment and cylinders for healthcare facilities (K926).

This proposal is submitted by the ICC Committee on Healthcare (CHC). The CHC was established by the ICC Board to evaluate and assess contemporary code issues relating to healthcare facilities. This is a joint effort between ICC and the American Society for Healthcare Engineering (ASHE), a subsidiary of the American Hospital Association, to eliminate duplication and conflicts in healthcare regulation. In 2017 the CHC held 2 open meetings and numerous conference calls, which included members of the committees as well as any interested parties, to discuss and debate the proposed changes. Information on the CHC, including: meeting agendas; minutes; reports; resource documents; presentations; and all other materials developed in conjunction with the CHC effort can be downloaded from the CHC website at: <https://www.iccsafe.org/codes-tech-support/cs/icc-committee-on-healthcare/>.

Cost Impact

The code change proposal will not increase or decrease the cost of construction .

This change is an operational change regarding training and will not increase the cost of construction on the healthcare industry.

Internal ID: 698

F296-18

IFC: 5306.2.2; IBC: [F] 427.2.2

Proponent: Kevin Scott, representing KH Scott & Associates LLC (khscottassoc@gmail.com)

2018 International Fire Code

Revise as follows:

5306.2.2 One-hour interior room. Where an exterior wall cannot be provided for the room, a 1-hour interior room shall be provided and shall be a room or enclosure separated from the remainder of the building by *fire barriers* constructed in accordance with Section 707 of the International Building Code or horizontal assemblies constructed in accordance with Section 711 of the International Building Code, or both, with a *fire-resistance rating* of not less than 1 hour. Openings between the room or enclosure and interior spaces shall be provided with self-closing, smoke- and draft-control assemblies having a *fire protection rating* of not less than 1 hour. An *automatic sprinkler system* shall be installed within the room. The room shall be exhausted through a duct to the exterior. Supply and exhaust ducts shall be enclosed in a 1-hour-rated shaft enclosure from the room to the exterior. *Approved* mechanical ventilation shall comply with the International Mechanical Code and be provided at a minimum rate of 1 cfm per square foot [0.00508 m³/(s • m²)] of the area of the room.

2018 International Building Code

[F] 427.2.2 One-hour interior room. Where an exterior wall cannot be provided for the room, a 1-hour interior room ~~or enclosure~~ shall be provided and shall be a room or enclosure separated from the remainder of the building by fire barriers constructed in accordance with Section 707 or horizontal assemblies constructed in accordance with Section 711, or both, with a fire-resistance rating of not less than 1 hour. Openings between the room or enclosure and interior spaces shall be provided with self-closing smoke- and draft-control assemblies having a fire protection rating of not less than 1 hour. An automatic sprinkler system shall be installed within the room. The room shall be exhausted through a duct to the exterior. Supply and exhaust ducts shall be enclosed in a 1-hour rated shaft enclosure from the room to the exterior. Approved mechanical ventilation shall comply with the International Mechanical Code and be provided with a minimum rate of 1 cubic foot per minute per square foot (0.00508 m³/s/m²) of the area of the room.

Reason:

These revisions are editorial in nature and do not alter the application of the code requirements.

For example, the addition of these words clarifies that the "opening" is not self-closing, but rather the opening is "provided with" self-closing assemblies.

Cost Impact

The code change proposal will not increase or decrease the cost of construction .

There is no change in application of the code requirements.

Internal ID: 2356

F297-18 Part I

IFC: 5306.5

Proponent: John Williams, Chair, representing Healthcare Committee (AHC@iccsafe.org); Michael O'Brian, Chair, representing FCAC (fcac@iccsafe.org)

2018 International Fire Code

Revise as follows:

5306.5 Medical gas systems and equipment. ~~Medical gas systems including, but not limited to, distribution piping, supply manifolds, connections, pressure regulators and relief devices and valves and equipment,~~ shall be installed, tested and labeled in accordance with NFPA 99 and the general provisions of this chapter. Existing medical gas systems and equipment shall be used and maintained in accordance with the use, maintenance, inspection and testing provisions of NFPA 99 for medical gas systems and equipment.

Internal ID: 693

F297-18 Part II

IPC: 1202.1

Proponent: John Williams, Chair, representing Healthcare Committee (AHC@iccsafe.org); Michael O'Brian, Chair, representing FCAC (fcac@iccsafe.org)

2018 International Plumbing Code

Revise as follows:

[F] 1202.1 Nonflammable medical gases. Nonflammable medical gas systems, inhalation anesthetic systems and vacuum piping systems shall be ~~designed-installed, tested and installed-labeled~~ in accordance with NFPA 99.

Exceptions:

1. This section shall not apply to portable systems or cylinder storage.
2. Vacuum system exhaust terminations shall comply with the International Mechanical Code.

Reason:

This change clarifies that the application of NFPA 99 includes the use, testing and labeling of medical gas systems and equipment (K909, K924 and K928).

This proposal is submitted by the ICC Fire Code Action Committee (FCAC) and the ICC Committee on Healthcare (CHC).

The FCAC was established by the ICC Board of Directors to pursue opportunities to improve and enhance assigned International Codes with regard to fire safety and hazardous materials in new and existing buildings and facilities and the protection of life and property in wildland urban interface areas. In 2017 the Fire-CAC has held 3 open meetings. In addition, there were numerous conference calls, Regional Work Group and Task Group meetings for the current code development cycle, which included members of the committees as well as any interested parties, to discuss and debate the proposed changes. Related documentation and reports are posted on the FCAC website at: <https://www.iccsafe.org/codes-tech-support/cs/fire-code-action-committee-fcac/>

The CHC was established by the ICC Board to evaluate and assess contemporary code issues relating to healthcare facilities. This is a joint effort between ICC and the American Society for Healthcare Engineering (ASHE), a subsidiary of the American Hospital Association, to eliminate duplication and conflicts in healthcare regulation. In 2017 the CHC held 2 open meetings and numerous conference calls, which included members of the committees as well as any interested parties, to discuss and debate the proposed changes. Information on the CHC, including: meeting agendas; minutes; reports; resource documents; presentations; and all other materials developed in conjunction with the CHC effort can be downloaded from the CHC website at: <https://www.iccsafe.org/codes-tech-support/cs/icc-committee-on-healthcare/>.

Cost Impact

The code change proposal will not increase or decrease the cost of construction .

This change is an operational change regarding use, maintenance and testing. This will not increase the cost of construction on the healthcare industry.

Internal ID: 3404

F298-18

IFC: 5307.3.2

Proponent: Stephen DiGiovanni, representing self (sdigiovanni@clarkcountynv.gov)

2018 International Fire Code

Revise as follows:

5307.3.2 Gas detection system. Where ventilation is not provided in accordance with Section 5307.3.1, a gas detection system shall be provided in rooms or indoor areas and in below-grade outdoor locations with insulated carbon dioxide systems. Carbon dioxide sensors shall be provided within 12 inches (305 mm) of the floor in the area where the gas is expected to accumulate or other *approved* locations. The system shall be designed as follows:

1. Activates an audible and visible supervisory alarm at a normally attended location upon detection of a carbon dioxide concentration of 5,000 ppm (9000 mg/m³).
2. Activates an audible and visible alarm within the room or immediate area where the system is installed and stops the flow of carbon dioxide upon detection of a carbon dioxide concentration of 30,000 ppm (54 000 mg/m³).

Reason:

This proposal seeks to add an automatic shut-off valve to the CO₂ system piping and require activation of that stop valve when the concentration reaches 30,000 PPM. NIOSH recommended limits for CO₂ exposure are as follows: 5,000 ppm is the time-weighted average limit; 30,000 ppm is the Short Term Exposure Limit for 15 minutes; and 40,000 PPM is Immediately Dangerous to Life and Health. With the increased use of liquefied carbon dioxide, and it's increased use in restaurants and other assembly occupancies, it is becoming more likely that a system pipe failure can lead to exposures to people that exceed 30,000 PPM if the flow is not stopped. The way the code is written, there is a supervisory alarm at 5,000 PPM, at which point in time it is expected that responsible personnel will mitigate the exposure. However, if the conditions have continued to worsen such that the 30,000 PPM alarm is triggered, there is concern that this expected manual intervention has not occurred or has not been effective. Adding an automatic shut-off valve at the discharge of the CO₂ source is a minor increase in costs that greatly increases the chances that the concentration of CO₂ does not rise significantly above 30,000 PPM.

Cost Impact

The code change proposal will increase the cost of construction .

This proposal adds an automatic shut-off valve, as well as wiring and relays between the valve and the detection panel. The costs associated with this installation is an increase from what is currently required in the code.

Internal ID: 1125

F299-18

IFC: 5601.1; IBC [F] 307.1.1

Proponent: Dave Frable, U.S. General Services Administration, representing U.S. General Services Administration

2018 International Fire Code

Revise as follows:

5601.1 Scope. The provisions of this chapter shall govern the possession, manufacture, storage, handling, sale and use of *explosives, explosive materials*, fireworks and small arms ammunition.

Exceptions:

1. The Armed Forces of the United States, Coast Guard or National Guard.
2. *Explosives* in forms prescribed by the official United States Pharmacopoeia.
3. The possession, storage and use of small arms ammunition where packaged in accordance with DOTn packaging requirements.
4. The possession, storage and use of not more than 1 pound (0.454 kg) of commercially manufactured sporting black powder, 20 pounds (9 kg) of smokeless powder and 10,000 small arms primers for hand loading of small arms ammunition for personal consumption.
5. The use of *explosive materials* by federal, state and local regulatory, law enforcement and fire agencies acting in their official capacities.
6. Special industrial *explosive* devices that in the aggregate contain less than 50 pounds (23 kg) of *explosive materials*.
7. The possession, storage and use of blank industrial-power load cartridges where packaged in accordance with DOTn packaging regulations.
8. Transportation in accordance with DOTn 49 CFR Parts 100-185.
9. Items preempted by federal regulations.
10. Federal law enforcement agencies acting in their official capacities storing explosive materials in accordance with the Bureau of Alcohol, Tobacco, Fire Arms and Explosives Regulations, 27 CFR, Part 555.

2018 International Building Code

Revise as follows:

[F] 307.1.1 Uses other than Group H. An occupancy that stores, uses or handles hazardous materials as described in one or more of the following items shall not be classified as Group H, but shall be classified as the occupancy that it most nearly resembles.

1. Buildings and structures occupied for the application of flammable finishes, provided that such buildings or areas conform to the requirements of Section 416 and the International Fire Code.
2. Wholesale and retail sales and storage of flammable and combustible liquids in mercantile occupancies conforming to the International Fire Code.
3. Closed piping system containing flammable or combustible liquids or gases utilized for the operation of machinery or equipment.
4. Cleaning establishments that utilize combustible liquid solvents having a flash point of 140°F (60°C) or higher in closed systems employing equipment *listed* by an *approved* testing agency, provided that this occupancy is separated from all other areas of the building by 1-hour *fire barriers* constructed in accordance with Section 707 or 1-hour *horizontal assemblies* constructed in accordance with Section 711, or both.
5. Cleaning establishments that utilize a liquid solvent having a flash point at or above 200°F (93°C).
6. Liquor stores and distributors without bulk storage.
7. Refrigeration systems.
8. The storage or utilization of materials for agricultural purposes on the premises.

9. Stationary storage battery systems installed in accordance with the International Fire Code.
10. Corrosive personal or household products in their original packaging used in retail display.
11. Commonly used corrosive building materials.
12. Buildings and structures occupied for aerosol product storage shall be classified as Group S-1, provided that such buildings conform to the requirements of the International Fire Code.
13. Display and storage of nonflammable solid and nonflammable or noncombustible liquid hazardous materials in quantities not exceeding the maximum allowable quantity per *control area* in Group M or S occupancies complying with Section 414.2.5.
14. The storage of black powder, smokeless propellant and small arms primers in Groups M and R-3 and special industrial explosive devices in Groups B, F, M and S, provided such storage conforms to the quantity limits and requirements prescribed in the International Fire Code.
15. Stationary fuel cell power systems installed in accordance with the International Fire Code.
16. Capacitor energy storage systems in accordance with the International Fire Code.
17. Group B higher education laboratory occupancies complying with Section 428 and Chapter 38 of the International Fire Code.
18. The storage and use of explosive materials by Federal law enforcement agencies acting in their official capacities in accordance with the Bureau of Alcohol, Tobacco, Fire Arms and Explosives Regulations, 27 CFR, Part 555.

Reason:

Several Federal Law Enforcement Agencies by the nature of their mission have a need to store explosive materials at or near their base of operation. For example, Federal Law Enforcement Agencies utilizing canine teams to provide explosive detection have a need to store explosive canine training aids and Federal Law Enforcement Agencies that confiscate explosive materials during their daily activities also need storage areas near their base operations to store these types of explosive materials. However, following the prescriptive storage requirements in Chapter 56 for explosive materials would prohibit the storage of these types of explosive materials within Federally-owned buildings and in some cases prohibit such storage on Federally-owned property. This proposed code change attempts to address this issue by including an additional exception that would permit Federal Law Enforcement Agencies acting in their official capacities to follow the requirements in the Bureau of Alcohol, Tobacco, Fire Arms and Explosives Regulations, 27 CFR, Part 555, Commerce in Explosives – Subpart K, in lieu of the requirements in Chapter 56.

Cost Impact

The code change proposal will not increase or decrease the cost of construction .

This proposed code change would only affect Federally-owned buildings and Federally-owned property based on primarily Federal Law Enforcement Agency operational issues and not construction costs.

Internal ID: 1879

F300-18

IFC: 5601.1.3

Proponent: William Koffel, representing American Pyrotechnics Association (wkoffel@koffel.com)

2018 International Fire Code

Revise as follows:

5601.1.3 Fireworks. The possession, manufacture, storage, sale, handling and use of fireworks are prohibited.

Exceptions:

1. Storage and handling of fireworks as allowed in Section 5604.
2. Manufacture, assembly and testing of fireworks as allowed in Section 5605.
3. The use of fireworks for fireworks displays as allowed in Section 5608.
4. The possession, storage, sale, handling and use of specific types of Division 1.4G fireworks where allowed by applicable laws, ordinances and regulations, provided that such fireworks and facilities comply with ~~NFPA 1124 Section 5609~~, CPSC 16 CFR Parts 1500 and 1507, and DOTn 49 CFR Parts 100–185, as applicable for consumer fireworks.

Reason:

The current edition of NFPA 1124 does not contain requirements that address the retail sales and storage of consumer fireworks.

This is a companion change to a proposal that expands Section 5609 to address consumer fireworks in a comprehensive manner without a reference to NFPA 1124.

Cost Impact

The code change proposal will not increase or decrease the cost of construction .

The requirements for Section 5609 are fairly consistent with industry practice and the provisions in previous editions of NFPA 1124.

Internal ID: 2233

F301-18

IFC: 5604.6.5

Proponent: Stephen DiGiovanni, representing self (sdigiovanni@clarkcountynv.gov)

2018 International Fire Code

Revise as follows:

5604.6.5 Signs and placards. Property on which Type 1 magazines and outdoor magazines of Types 2, 4 and 5 are located shall be posted with signs stating: NO SMOKING and EXPLOSIVES—KEEP OFF. These signs shall be of contrasting colors with a minimum letter height of 3 inches (76 mm) with a minimum brush stroke of $\frac{1}{2}$ inch (12.7 mm). The signs shall be located to minimize the possibility of a bullet shot at the sign hitting the magazine.

Reason:

This is a simple proposal to add a requirement to provide NO SMOKING signs to limit sources of ignition where explosive materials are stored.

Cost Impact

The code change proposal will increase the cost of construction .

This proposal will increase the cost of construction by requiring an additional sign, or a larger sign, to be provided where storing explosive materials in magazines.

Internal ID: 1077

F302-18

IFC: 5606.1, 5606.6 (New), 5606.6.1 (New), 5606.6.2 (New), 5606.6.3 (New), 5606.6.4 (New), 5606.6.5 (New), 5606.6.6 (New), 5606.6.7 (New), 5606.6.8 (New)

Proponent: Adria Reinertson, Riverside County Fire Department, representing Riverside County Fire Department, California Fire Chiefs Association (adriar@moval.org)

2018 International Fire Code

Revise as follows:

5606.1 General. Indoor storage and display of black powder, smokeless propellants, small arms primers ~~and~~ small arms ammunition, and commercial reloading shall comply with this section and NFPA 495.

Add new text as follows:

5606.6 Commercial Reloading. Commercial reloading of small arms ammunition shall comply with Sections 5606.6.1 through 5606.6.8.

5606.6.1 Electrical. Areas within 3 feet of reloading equipment shall be Class I, Division 2, Group A type.

5606.6.2 Exhaust Fans. Squirrel cage blowers shall not be used for exhausting hazardous fumes, vapors or gases. Only nonferrous fan blades shall be used for fans located within the ductwork and through which hazardous materials are exhausted. Motors shall be located outside the duct.

5606.6.3 Work Stations. Work stations shall be separated by distance, barrier or other approved alternatives so that fire in one station will not ignite material in another work station.

5606.6.4 Personnel Limits. The number of occupants in each process building and in each magazine shall not exceed the number necessary for proper conduct of production operations.

5606.6.5 Approved Containers. Smokeless powder shall be kept in its original container.

5606.6.6 Static Controls. The work area shall be provided with approved static controls.

5606.6.7 Waste Disposal. Approved receptacles with covers shall be provided for each location for disposing of waste material and debris. These waste receptacles shall be emptied and cleaned as often as necessary but not less than once each day or at the end of each shift.

5606.6.8 Safety Rules. General safety rules and operating instructions governing the particular operation or process conducted at that location shall be available at each location.

Reason:

This proposal does not limit commercial loading and reloading, it provides safety measures to ensure hazards are properly mitigated. These provisions will give the code official the tools to consistently apply life safety standards to assist business owners to efficiently conduct business, Due to the similar hazards in the classification of fireworks, verbiage from the fireworks section is utilized.

Cost Impact

The code change proposal will increase the cost of construction .

This proposal may minimally increase the cost of construction and/or operations due to the added safety features.

Internal ID: 606

F303-18

IFC: 5609

Proponent: William Koffel, representing American Pyrotechnics Association (wkoffel@koffel.com)

2018 International Fire Code

Revise as follows:

SECTION 5609 TEMPORARY STORAGE OF CONSUMER RETAIL SALES AND STORAGE OF CONSUMER FIREWORKS

5609.1 General. Where the display or temporary retail sales and associated storage of fireworks 1.4G (consumer fireworks) is allowed by Section 5601.1.3, Exception 4, such display or storage shall comply with the applicable requirements of NFPA 1124.~~this section.~~

Add new text as follows:

5609.2 Retail sales of consumer fireworks. Retail sales of consumer fireworks in both new and existing buildings, structures, and facilities shall comply with the requirements of this section unless otherwise indicated.

5609.2.1 Special Requirements for Retail Sales of Consumer Fireworks. Retail sales of consumer fireworks, including their related storage and display for sale of such fireworks, shall be in accordance with this section.

5609.2.1.1 Occupancy classification. Retail sales of consumer fireworks in buildings complying with this Section shall be classified as Use Group M.

5609.2.1.2 Prohibition. The retail sales of fireworks and novelties that do not comply with the regulations of the U.S. Consumer Product Safety Commission as set forth in 16 CFR 1500 and 1507 and the regulations of the U.S. Department of Transportation as set forth in 49 CFR 100 to 178, including their related storage and display for sale, shall be prohibited.

5609.2.2 Third party testing. Consumer fireworks shall be tested and certified by an approved, independent third party testing agency for compliance with the regulations of the Consumer Product Safety Commission (CPSC) as set forth in 16 CFR 1500 and 1507, using a test sampling plan that meets CPSC requirements.

5609.2.3 Permits. Where required by state or local laws, ordinances, or regulations, a permit for the following shall be obtained for the storage of consumer fireworks in connection with the retail display or sale of consumer fireworks to the public.

5609.2.4 Fire department access. Any portion of an exterior wall shall be accessible within 150 ft. (45.7 m) of a public way or an approved fire department access road.

5609.2.5 Smoking. Smoking shall be regulated in accordance with Sections 5609.2.5.1 and 5609.2.5.2

5609.2.5.1 Location. Smoking shall not be permitted inside or within 50 ft. (15.5 m) of sales facility

5609.2.5.2 Signage. At least one sign that reads as follows, in letters at least 2 in. (51 mm) high on a contrasting background, shall be conspicuously posted at each entrance or within 10 ft. (3.05 m) of every aisle directly serving the fireworks sales area:

FIREWORKS

NO SMOKING

5609.2.6 Retail sales displays. Retail displays of fireworks shall be in accordance with Sections 5609.2.6.1 through 5609.6.3.3.

5609.6.1 Height of sales display. Partitions, counters, shelving, cases and similar space dividers shall not exceed 6 ft. (1.8 m) in height above the floor surface inside the perimeter of the retail sales area. Where located along the

perimeter of the consumer fireworks retail sales area, the maximum height of sales display shall be limited to 12 ft. (3.6 m).

5609.2.6.2 Flame breaks. Where continuous displays of consumer fireworks are located on shelving, cases, counters, and similar display fixtures, a flame break shall be provided so that the maximum distance between flame breaks does not exceed 16 ft (4.9 m) where measured along the length of the display.

5609.2.6.2.1 Extension of Flame break. The flame break shall extend be in accordance with the following:

1. From the display surface to not less than 6 in. (150 mm) above the full height of the displayed merchandise or to the underside of the display surface directly above.

2. For the full depth of the displayed merchandise.

5609.2.6.2.2 Mixed packaging. Where packaged fireworks merchandise is displayed on the same level as individual unpackaged fireworks devices, the flame break required in 5609.2.7.2.1 shall not be required where in accordance with both of the following:

1. The length of the display level containing individual unpackaged fireworks devices is interrupted by packaged fireworks merchandise, or open space, or any combination thereof, having a continuous length of not less than 8 ft. (2.4 m).

2. The distance between flame breaks does not exceed 32 ft. (9.8 m).

5609.2.6.2.3 Continous storage. Where a merchandise display level contains packaged fireworks merchandise, such merchandise shall be permitted to be displayed in a continuous length on the same level, where the display does not exceed 32 ft. (9.8 m) without the flame break required in 5609.2.6.2.1.

5609.6.2.4 Aisle. . An aisle having a minimum width of 48 in. (1.2 m) shall be permitted to substitute for the flame break.

5609.2.6.2.5 Displays facing aisles. Where displays of merchandise face aisles that run along both long sides of the display fixtures or display surface, a flame break shall be installed lengthwise between the abutting display fixtures or along the approximate longitudinal centerline of the display surface so as to separate the merchandise facing one of the aisles from the merchandise that abuts it facing the other aisle.

5609.2.6.2.6 Freestanding displays. Freestanding display racks, pallets, tables, or bins containing packaged fireworks merchandise shall be permitted without flame breaks, provided the dimensions of the area occupied by the fireworks merchandise do not exceed 4 ft. (1.2 m) in width, 8 ft. (2.4 m) in length, and 6 ft. (1.8 m) in height, and the displayed fireworks merchandise is separated from other displays of merchandise by aisles having a minimum clear width of 4 ft. (1.2 m).

5609.2.6.2.7 Displays of hardboard panels. Where both of the facing vertical surfaces of the abutting display fixtures are constructed of perforated hardboard panels not less than ¼ in. (6 mm) thick that are separated from each other by an open space not less than 1 ½ in. (38 mm) wide, a flame break shall not be required.

5609.2.6.2.8 Permanent sales facilities. In Permanent Sales Facilities the longitudinal flame break shall not be required where the display fixture or surface is adjacent to an aisle that is not used for public egress.

5609.2.6.3 Shelving. Shelving shall be in accordance with 5609.2.6.3.1 through 5609.2.6.3.3

5609.2.6.3.1 General. Shelving or other surfaces used to support fireworks display merchandise shall be permitted to have not more than 10 percent of the area of the shelf contain holes or other openings.

5609.2.6.3.2 Openings. The 10 percent limitation on the area of holes or other openings in the shelf used to support fireworks display merchandise shall not be applicable under the following conditions:

1. Where both of the facing vertical surfaces of the abutting display fixtures are constructed of perforated hardboard panels not less than ¼ in. (6 mm) thick and separated from each other by an open space not less than 1 ½ in. (38 mm) wide.

2. Where such merchandise is suspended from or fastened to the shelf or surface or is displayed as packaged merchandise on the surface or in bins.

5609.2.6.3.3 Flame breaks and solid display. Flame breaks and solid display surfaces shall not be required for packaged fireworks merchandise displayed in bins or display racks or on pallets or tables located at the end of a row of display fixtures where the following conditions are met:

1. Such end displays are separated from the ends of the display fixtures by an open space not less than 3 in. (76 mm) wide.
2. The fireworks merchandise occupies an area having dimensions not greater than the width of the end of the row of display fixtures and a depth not greater than 30 in. (910 mm).
3. The minimum required widths of the adjacent aisles are maintained, but in no case is the aisle width less than 48 in. (1.2m).

5609.2.7 Covered fuses. Only consumer fireworks meeting the criteria for covered fuses shall be permitted.

5609.2.7.1 Packaged fireworks. A consumer fireworks device shall be considered as having a covered fuse if the fireworks device is contained within a packaged arrangement, container, or wrapper that is configured such that the fuse of the fireworks device cannot be touched directly by a person handling the fireworks without the person having to puncture or tear the packaging or wrapper, unseal or break open a package or container, or otherwise damage or destroy the packaging material, wrapping, or container within which the fireworks are contained.

5609.2.8 Aerial Devices. Aerial devices shall be packaged and displayed for sale in a manner that will limit travel distance of ejected pyrotechnic components if ignition of the fireworks occurs.

5609.2.9 Other Materials. Combustible materials and merchandise shall not be stored directly above the consumer fireworks in retail sales.

5609.2.10 Training. All personnel handling consumer fireworks shall receive safety training related to the performance of their duties.

5609.3 Retail Sales of Consumer Fireworks in Permanent Sales Facilities. Permanent sales facilities for retail sale of consumer fire works shall comply with Sections 5609.3.1 through 5609.3.7.3.

5609.3.1 Quantity Limitations. The floor area occupied by the retail displays of consumer fireworks in Permanent Sales Facilities shall not exceed 40 percent of the available floor area within the retail sales area.

5609.3.2 Construction of Permanent Sales Facilities. New permanent sales facilities shall not exceed one story in height.

5609.3.3 Multiple-Tenant buidlings

. Multiple-tenant buildings shall comply with Sections 5609.3.3.1 and 5609.3.3.2.

5609.3.3.1 Buildings with other tenants. Where new permanent sales facilities are located in a building containing other tenants, the permanent sales facility shall be separated from the other tenants by fire barriers with a minimum fire resistance rating of two hours and having no openings.

5609.3.3.2 Sprinkler protection. Where the new permanent sales facilities are protected with an automatic sprinkler system complying with 903.3.1.1, the fire resistance rating of the fire barrier required by 5609.3.3.1 shall be permitted to be not less than 1 hour.

5609.3.4 Fire protection. An automatic sprinkler system complying with 903.3.1.1 shall be provided throughout permanent sales facilities in which fireworks sales are conducted as follows:

1. In new permanent sales facilities greater than 3000 ft² (276 m²) in area
2. In existing permanent sales facilities greater than 7500 ft² (694 m²) in area

5609.3.5 Storage rooms. Storage rooms, containing consumer fireworks in a new Permanent Sales Facilities shall be protected with an automatic sprinkler system complying with 903.3.1.1 or separated from the retail sales area by a fire barrier having a fire resistance rating of not less than 1 hour.

5609.3.6 Fire alarms. A fire alarm system shall be provided in accordance with Section 907.

5609.3.7 Separation distances. Separation distances shall be provided in accordance with Section 5609.3.7.1 through 5609.3.7.3 as applicable.

5609.3.7.1 New facilities

. New Permanent Sales Facilities shall be separated from adjacent permanent buildings and structures in accordance with Table 5609.3.7.1.

5609.3.7.2 Existing facilities. Existing Permanent Sales Facilities shall be separated from adjacent permanent buildings and structures by not less than 10 ft (3.05m) or shall be separated by a wall with a 1-hour fire resistance rating.

**Table 5609.3.7.1
SEPARATION DISTANCE BETWEEN NEW PERMANENT BUILDINGS AND STRUCTURES**

Seperation distance		Exterior Wall Fireresistance Rating (hr)	Exterior Wall Opening Protection Rating (hr)
Ft	M		
<u>< 10</u>	<u><3.05</u>	<u>2</u>	<u>1-1/2</u>
<u>>10 - <60</u>	<u>>3.05- <18.3</u>	<u>1</u>	<u>3/4</u>
<u>> 60</u>	<u>>18.3</u>	<u>0</u>	<u>0</u>

5609.3.7.3 Parking.. No motor vehicle or trailer used for the storage of consumer fireworks shall be parked with 10 ft. (3 m) of a permanent sales facility, except when the vehicle or trailer is delivering, loading, or unloading fireworks or other merchandise and materials used, stored, or displayed for sale in the facility.

5609.3.8 Means of Egress. Means of egress in permanent retail sales facilities shall be in accordance with Sections 5609.3.8.1 through 5609.3.8.3.

5609.3.8.1 Number of exits. The minimum number of exits provided from the retail sales area shall be not less than three.

5609.3.8.2 Exit access travel distance. Exits provided for permanent sales facilities shall be located so that the exit access travel distance does not exceed 75 ft. (22.9 m).

5609.3.8.3 Emergency lighting. Emergency lighting shall be provided for permanent sales facilities.

5609.3.9 Operations. Operations of retail sales of consumer fireworks in permanent facilities shall be in accordance with Sections 3609.3.9.1 through 5609.3.9.3.

5609.3.9.1 Distances from Entrances and Exits. Distance to entrances and exits shall comply with Sections 5609.3.9.1.1 and 5609.3.9.1.2.

5609.3.9.1.1 Public entrances. No consumer fireworks shall be displayed for sale or stored within 5 ft (1.5 m) of any public entrance in an enclosed building or structure.

5609.3.9.1.2 Private entrances. No consumer fireworks shall be displayed for sale or stored within 2 ft (0.6 m) of any exit or private entrance in an enclosed building or structure.

5609.3.9.2 Security. Fire works shall be kept Secure in permanent sales facilities in accordance with Sections 5609.3.9.2.1 through 5609.3.9.2.3.

5609.3.9.2.1 Non business hours. Permanent sales facilities shall be secured when unoccupied and not open for business, unless fireworks are not kept in the facility during such times.

5609.3.9.2.2 Removal and transferring. The fireworks displayed or stored in a permanent sales facilities shall be allowed to be removed and transferred to a temporary storage structure or location.

5609.3.9.2.3 Ignition sources. Fireworks shall not be ignited, discharged, or otherwise used within 300 ft. (91.5 m) of a permanent sales facilities.

5609.3.9.3 Display and Handling. Not less than 50 percent of the available floor area within the retail sales area shall be open space that is unoccupied by retail displays and used only for aisles and cross-aisles.

5609.4 Requirements for Retails Sales of Consumer Fireworks in Temporary Sales Facilities. . The retail sales of consumer fire works in temporary sales facilities shall be in accordance with Sections 5609.4.1 through 5609.4.6.4.

5609.4.1 Construction of Temporary Sales Facilities. New Temporary Sales Facilities shall not exceed one story in height.

Exception: Temporary Sales Facility stands greater than 1600 ft² (148 m²) in area that also meet the construction

requirements for a permanent structure.

5609.4.2 Sale from vehicles. The sale of consumer fireworks from vehicles including automobiles, trucks, motor homes and travel trailers is not permitted except when the vehicle meets the requirements for a Temporary Sales Facility stand.

5609.4.3 Signage. In addition to the signage required in 5609.2.6 at least one sign that reads as follows, in letters at least 4 in. (102 mm) high on a contrasting background, shall be conspicuously posted on the exterior the temporary sales facility:

NO FIREWORKS DISCHARGE

WITHIN 100 FEET

5609.4.4 Separation Distances. Temporary sales facilities shall be located as specified in Table 5609.4.4 and in accordance with Sections 5609.4.4.1 and 5609.4.4.2.

5609.4.4.1 Clearance to Combustibles. The area located within 10 ft. (9 m) of a temporary sales facilities shall be kept free of accumulated dry grass, dry brush, and combustible debris.

5609.4.4.2 Parking. No motor vehicle or trailer used for the storage of consumer fireworks shall be parked within 10 ft. (3 m) of a Temporary Sales Facilities, except when the vehicle or trailer is delivering, loading, or unloading fireworks or other merchandise and materials used, stored, or displayed for sale in the facility.

**Table 5609.4.4
MINIMUM SEPARATION DISTANCES FOR TEMPORARY SALES FACILITIES**

Type	Separation Distance											
	Buildings		Combustibles		Tents		Vehicle Parking		Stands		Storage of Fireworks	
	Ft	M	Ft	M	Ft	M	Ft	M	Ft	M	Ft	M
Tents	20	6.1	20	6.1	20	6.1	10	3.05	20	6.1	20	6.1
Stands	20	6.1	10	3.05	20	6.1	10	3.05	20	6.1	20	6.1

5609.4.5 Means of Egress. Means of egress and temporary retail sales of consumer fire works shall be in compliance with Sections 5609.4.5.1 through 5609.4.5.6.

5609.4.5.1 Number of Exits. The minimum number of exits provided from the retail sales area shall be not less than three for Temporary Sales Facilities that are larger than 1,200 ft². All other Temporary Sales Facilities shall have a minimum of two exits, regardless of area.

5609.4.5.2 Egress through storage rooms. Required means of egress from the retail sales area shall not be allowed to pass through storage rooms or areas.

5609.4.5.3 Egress Travel Distance. Egress travel distance shall be in accordance with Sections 5609.4.5.3.1 and 5609.4.5.3.2.

5609.4.5.3.1 Exits provided for Temporary Sales . Facilities tents shall be located so that the exit access travel distance does not exceed 75 ft. (22.9 m).

5609.4.5.3.2 Exits provided for Temporary Sales. Facilities stands shall be located so that the exit access travel distance does not exceed 35 ft. (10.6 m).

5609.4.5.4 Aisles. Aisles shall have a minimum clear width of 48 in. (1.2 m) except in temporary sales facilities stands where the interior is not accessible to the public, the minimum clear width of aisles shall be 28 in. (710 mm).

5609.4.5.5 Dead-end aisles. Dead-end aisles shall be prohibited.

5609.4.5.6 Emergency Lighting. Emergency lighting shall be provided for temporary sales facilities. Emergency lighting shall not be required in Temporary Sales Facilities that are not open for business after dusk or for Temporary Sales Facilities stands where the interior is not accessible to the public.

5609.4.6 Sales Display. Consumer fireworks shall be displayed in a manner that prevents the fireworks from being handled by persons other than those operating, supervising, or working in the Temporary Sales Facilities stand where the stand does not allow access to the interior by the public.

5609.4.7 Portable Generators. Portable generators shall be in accordance with Sections 5609.4.7.1 through 5609.4.7.4.

5609.4.7.1 Fuel. Fuel for generators shall be permitted to be Class I, Class II, or Class III liquids and shall be limited to not more than 5 gallons (18.9 L) unless the generator fuel storage is located at least 50 ft. (15.2 m) from the temporary sales facility.

5609.4.7.2 Limitations. Portable generators supplying power to Temporary Sales Facilities shall use only Class I or Class III combustible liquid fuels.

5609.4.7.3 Separation of generators. Portable generators shall be located not less than 20 ft. (6.1 m) from the Temporary Sales Facilities.

5609.4.7.4 Separation of fuels. Generator fuels shall be stored not less than 20 ft. (6.1 m) from the Temporary Sales Facilities.

5609.5 Requirements for Retail Sales of Consumer Fireworks in Stores. Retail sale of consumer fireworks shall comply with Section 5609.5.1 through 5609.5.6

5609.5.1 Applicability. The requirements of Section 5609.4 do not apply where both of the following conditions exist:

1. The area of the retail sales floor occupied by the retail displays of consumer fireworks does not exceed 25 percent of the area of the retail sales floor in the building or 600 ft² (55.5m²), whichever is less.
2. The consumer fireworks are displayed and sold in a manner approved by the fire code official and comply with the applicable provisions of this code, federal and state law, and local ordinances.

5609.5.2 Requirements. Consumer fireworks displayed for sale in stores shall comply with all of the following:

1. Such fireworks shall be under the visual supervision of a store employee or other responsible party while the store is open to the public.
2. Such fireworks shall be packaged fireworks merchandise.
3. Such fireworks shall be packaged and displayed for sale in a manner that will limit travel distance of ejected pyro-technical components if ignition of the fireworks occurs.
4. Where consumer fireworks meeting the description of aerial devices and audible ground devices are sold, such devices shall be displayed for sale in an area of the store that is physically separated from the rest of the store in a manner that restricts entry by the public, and the area of the store shall be provided with not less than two means of egress, so located that there is no common path of travel and the distance to reach an egress point from the area does not exceed 35 ft (10.7m).

5609.5.3 Automatic Sprinkler System. The store shall be protected with an automatic sprinkler system in accordance with 903.3.1.1 in accordance with the following:

1. New stores greater than 3000 ft² (552.2 m²) in area
2. Existing stores greater than 7500 ft² (694 m²) in area

5609.5.4 Fire Alarm System. A fire alarm system shall be provided as required by Section 907. In addition, in stores greater than 3000 ft² (280 m²), a public address system or a means for manually activating audible and visible alarm indicating devices located throughout the facility shall be provided at a constantly attended location when the store is occupied.

5609.5.5 Storage Rooms. Storage rooms containing consumer fireworks in a store shall be protected with an automatic sprinkler system complying with 903.3.1.1 or shall be separated from the retail sales area by a fire barrier having a fire resistance rating of not less than 1 hour.

5609.5.6 Means of Egress. Exits provided for stores shall be located so that the exit access travel distance from the area where consumer fireworks are displayed does not exceed 75 ft. (22.9 m).

5609.6 Storage of Consumer Fireworks. The storage of consumer fireworks shall comply with Sections 5609.6.1 through 5609.6.9.3

5609.6.1 Non applicability. This section shall not apply to buildings or facilities where the net weight of the pyrotechnic content of consumer fireworks stored does not exceed 125 lb., or 250 lb. where the building is protected throughout with an automatic sprinkler system complying with 903.3.1.1

5609.6.2 Storage locations. Consumer fireworks storage buildings shall not also be used as a magazine for the storage of other explosive materials. Consumer fireworks shall be permitted to be stored in a magazine.

5609.6.3 Reworking and processing. Any reworking or processing of consumer fireworks shall only be permitted to be performed in a building meeting the requirements of NFPA 1124 for Process Buildings.

5609.6.4 Occupancy restrictions. Consumer fireworks storage buildings shall not be used for residential occupancies and shall not be located in residential areas.

5609.6.5 Finished products. Finished consumer fireworks at a manufacturing or distribution facility shall be stored in consumer fireworks storage buildings, trailers, semitrailers, metal shipping containers, or magazines.

5609.6.6 Receiving and packaging. Receiving, picking, packing, packaging, and shipping shall be permitted in

consumer fireworks storage buildings or areas.

5609.6.7 Separation Distances. Consumer fireworks storage or work buildings at distribution facilities shall be separated from adjacent permanent buildings and structures in accordance with Table 5609.6.7

Table 5609.6.7
SEPARATION DISTANCE FOR CONSUMER FIREWORKS STORAGE OR WORK BUILDINGS

<u>Separation distances</u>		<u>Exterior Wall Fireresistance Rating (hr)</u>	<u>Exterior Wall Opening Protection Rating (hr)</u>
<u>Ft</u>	<u>M</u>		
<u>< 10</u>	<u>< 3.05</u>	<u>2</u>	<u>1-1/2</u>
<u>>10 - <60</u>	<u>>3.05- <18.3</u>	<u>1</u>	<u>3/4</u>
<u>> 60</u>	<u>>18.3</u>	<u>0</u>	<u>0</u>

5609.6.8 Operations. Operations shall be in accordance with Sections 5609.8.1 through 5609.6.8.

5609.6.8.1 Receiving and storing. Receiving, storing, picking from cartons, packing into cartons, packaging into retail packages including assortments, shipping, and other similar operations involving finished consumer fireworks shall be permitted in consumer fireworks storage or work buildings, rooms, or areas that meet the requirements of this chapter.

5609.6.8.2 Picking, sorting and packaging. Picking, sorting, packaging, packing, and other similar operations involving finished consumer fireworks shall be conducted in consumer fireworks work buildings or consumer fireworks work rooms or areas in consumer fireworks storage buildings that meet the requirements of this chapter.

5609.6.8.3 Locking doors and windows. Exterior doors and windows shall be kept locked when the building is not occupied or otherwise attended.

5609.6.8.4 Consumer fireworks. 5609.6.8.4 Consumer fireworks shall be in accordance with the following:

1. Consumer fireworks shall be stored in DOT-approved packaging.
2. Cartons shall be stacked neatly and in a stable manner.
3. Consumer fireworks returned to these buildings shall be permitted to be stored temporarily in cartons until repackaging or repacking can be performed.
4. Firearms, unless carried by authorized personnel or law enforcement personnel, shall not be permitted inside a consumer fireworks storage or work building, room, or area or within 50 ft. (15.2 m) of stored consumer fireworks.

5609.6.9 Housekeeping. Housekeeping shall comply with Section 5609.6.9.1 through 5609.6.9.3.

5609.6.9.1 Loose black powder. Loose black powder or other exposed pyrotechnic composition shall be prohibited.

If loose composition is discovered, it shall be removed immediately and disposed of in an approved manner.

5609.6.9.2 Fireworks storage or work areas. Consumer fireworks storage or work buildings, rooms, or areas shall comply with all of the following:

1. Interiors shall be kept clean, dry and free of grit and rubbish.
2. Tools used for cleaning up loose pyrotechnic composition shall not have spark-producing metal parts.
3. Sweepings shall be disposed of in an approved manner.

5609.6.9.3 Clearance. The area around consumer fireworks storage or work buildings shall be kept clear of brush, dried vegetation, rubbish, and similar combustibles for a distance of at least 25 ft. (7.6 m).

Reason:

The current edition of NFPA 1124 no longer contains requirements addressing the retail sales and storage of consumer fireworks. Whereas almost every state allows the sale of some consumer fireworks, the fire official has no requirements to enforce that specifically address such facilities. The proposal is not about whether the sale of consumer fireworks should be permitted; but rather, where they are permitted the proposal provides a minimum set of requirements that a fire official can apply to provide an acceptable level of safety.

The requirements contained in this proposal are not as comprehensive as the standalone requirements contained in previous editions of NFPA 1124. Instead, the approach taken was to rely on other sections of the IFC to address provisions such as illumination of the means of egress, portable fire extinguishers, electrical equipment, etc. Instead, the proposed revisions focus on requirements that are mostly unique to consumer fireworks facilities such as flame breaks and covered fuses.

The proposal contains a set of general requirements that apply to all facilities in which consumer fireworks are sold (5609.2). The general provisions are then followed by requirements unique to three separate types of facilities: permanent sales facilities (5609.3); temporary sales facilities (5609.4); and retail stores in which consumer fireworks are displayed and sold along with other goods and merchandise (5609.5). The storage related to the sale of consumer fireworks is covered in Section 5609.6.

Cost Impact

The code change proposal will not increase or decrease the cost of construction.

The transition from the requirements of NFPA 1124 to the proposed requirements for Section 5609 should not impact the cost of construction. Since previous editions of the IFC require compliance with NFPA 1124 and since the proposed new sections and other existing sections of the I-codes are technically consistent with NFPA 1124-2013, there should not be an impact on the cost of construction.

Internal ID: 2056

F304-18

IFC: TABLE 5703.6.2, Chapter 80

Proponent: Bob Torbin, OmegaFlex, representing OmegaFlex (bob.torbin@omegaflex.net)

2018 International Fire Code

Revise as follows:

**TABLE 5703.6.2
PIPING STANDARDS**

PIPING USE	STANDARD
Power Piping	ASME B31.1
Process Piping	ASME B31.3
Pipeline Transportation Systems for Liquid Hydrocarbons and Other Liquids	ASME B31.4
Building Services Piping	ASME B31.9
Double Containment Piping	UL971A: UL1369

Add new standard(s) follows:

UL

Underwriters Laboratories LLC
333 Pfingsten Road
Northbrook IL 60062

971A -2006:

Outline of Investigation for Metallic Underground Fuel Pipe

1369-18:

Aboveground Piping Requirements

Reason:

This proposal covers metallic and composite primary carrier, secondary containment, and integral primary/secondary piping systems (piping and fittings) intended for above and below ground use in applications for the distribution of petroleum-based flammable and combustible liquids. The intent and design of double containment systems are focused on preventing fuel/liquid leaks that could result in severe fire hazards.

The primary metallic (316 stainless steel) tubing is a zero-permeation pipe which is highly resistant to corrosion with exceptional crush resistance. The UV stabilized Nylon 12 protective containment layer offers exceptional resistance to hydrocarbons, chemical and water exposure, and carries a 50 psig rating. An EFEP secondary barrier jacket layer is bonded to the Nylon 12 protective layer to offer secondary containment with exceptional permeation resistance for product compatibility. The interstitial space between the tubing and jacket allows continuous monitoring for leak detection, with a 50 psig rating for pressurized systems. The self-flaring fitting provides a metal to metal sealing surface with excellent reliability and is field-attachable using standard hand tools. This class of piping product has been used (above and below grade) for a variety of fuels for several years without failure for many applications such as marinas, gasoline stations and small power generators.

Cost Impact

The code change proposal will decrease the cost of construction .

The use of a listed encasement system results in cost savings because the piping and encasement are installed simultaneously. This avoids the labor cost of separately installing the conduit and piping. In addition, the sealing and venting methods (when required) are also integrated within the encasement system, thus eliminating the need to separately assemble and/or install sealing and venting components within standard conduit.

Analysis: A review of the standards proposed for inclusion in the code, UL 971A -2006 and UL 1369-18, with regard to the ICC criteria for referenced standards (Section 3.6 of CP#28) will be posted on the ICC website on or before April 2, 2018.

Internal ID: 1106

F305-18

IFC: 5703.7 (New), Chapter 80

Proponent: Jonathan Roberts, UL LLC, representing UL LLC (jonathan.roberts@ul.com)

2018 International Fire Code

Add new text as follows:

5703.7 Fuel line piping protection. Fuel lines supplying a generator providing required emergency power inside a building identified as Risk Categories III and IV by Table 1604.5 of the International Building Code shall be separated from areas of the building other than the room the generator is located in by one of the following methods:

1. A fire-resistant pipe-protection system that has been tested in accordance with UL 1489. The system shall be installed as tested and in accordance with the manufacturer's installation instructions, and shall have a rating of not less than 2 hours. Where the building is protected throughout with an automatic sprinkler system installed in accordance with Sections 903.3.1.1 or 903.3.1.2, the required rating shall be reduced to 1 hour.
2. An assembly that has a fire-resistance rating of not less than 2 hours. Where the building is protected throughout with an automatic sprinkler system installed in accordance with Sections 903.3.1.1 or 903.3.1.2, the required fire-resistance rating shall be reduced to 1 hour.
3. Other approved methods.

Add new standard(s) follows:

UL

Underwriters Laboratories LLC
333 Pfingsten Road
Northbrook IL 60062

1489-2016:

Fire Resistant Pipe Protection Systems Carrying Combustible Liquids

Reason:

This proposal is intended to require fuel lines supplying a generator providing required emergency power in buildings identified as Risk Categories III and IV be separated from areas of the building other than the room the generator is located in using one of three methods. The second two methods shown, a fire-resistance-rated assembly or other approved methods, are currently specified as options for separating fuel lines supplying generators in Section 1203.1.2 of the IFC, and Sections 403.4.8.2 and 2702.1.2 of the IBC. The new method proposed herein is through the use of a fire-resistant pipe-protection system. This new method is also being proposed in separate proposals for the above referenced Sections of the IFC and IBC.

The separation of fuel lines is being proposed for Risk Category III and IV buildings. Buildings identified as Risk Category III are those building and other structures that represent a substantial hazard to human life in the event of failure. Buildings identified as Risk Category IV are those buildings and other structures designated as essential facilities. As such, these two Risk Categories include facilities where the operation of emergency and standby power is especially critical.

UL 1489 addresses the fire-resistive performance of fuel lines protected for an hourly rating. UL 1489 compliments the two standards currently referenced in the International Fire Code for establishing fire-resistance ratings: ASTM E119 and UL 263. The standard describes the same test equipment and same time-temperature fire exposure as ASTM E119 and UL 263. However, the sample testing configuration specifically addresses pipe-protection systems. The Conditions of Acceptance follow the intent of ASTM E119 and UL 263, but specifically address the performance requirements for fire-resistant pipe-protection systems. Specifically the Conditions of Acceptance require 1) resistance to the fire and hose stream exposure without developing openings in the pipe, and 2) preventing a temperature increase exceeding 325°F at any single point or 250°F at any cross section along the pipe.

Cost Impact

The code change proposal will increase the cost of construction .

This proposal will increase the cost of construction because it requires fire protection of fuel lines not previously required to be protected.

Analysis: A review of the standard proposed for inclusion in the code, UL1489-2016, with regard to the ICC criteria for

referenced standards (Section 3.6 of CP#28) will be posted on the ICC website on or before April 2, 2018.

Internal ID: 228

F306-18

IFC: 5704.2.11.4.2, 5704.2.11.4.2.1 (New)

Proponent: Adria Reinertson, Riverside County Fire Department, representing Riverside County Fire Department, California Fire Chiefs Association (adriar@moval.org)

2018 International Fire Code

5704.2.11.4.2 Leak detection. Underground storage tank systems shall be provided with an *approved* method of leak detection from any component of the system that is designed and installed in accordance with NFPA 30.

Add new text as follows:

5704.2.11.4.2.1 Location. The leak detection panel status shall be annunciated at an approved on-site location.

Reason:

Enables the fire code official to locate the leak detection panel in a conspicuous location where it will be readily visible and accessible by on-site personnel.

Cost Impact

The code change proposal will not increase or decrease the cost of construction .

This proposal will not increase the cost of construction, it is simply a requirement of where to locate the panel.

Internal ID: 609

F307-18

IFC: 5704.2.13.1.5, Chapter 80

Proponent: Jeffrey Shapiro, representing STI/SPFA (jeff.shapiro@intlcodeconsultants.com)

2018 International Fire Code

Revise as follows:

5704.2.13.1.5 Reinstallation of underground tanks. Tanks that are to be reinstalled for flammable or *combustible liquid* service shall be in accordance with this chapter, ASME *Boiler and Pressure Vessel Code* (Section VIII), ~~API 12-P~~, API1615, UL 58 and UL 1316.

Update standard(s) as follows:

API

American Petroleum Institute
1220 L Street, NW
Washington DC 20005

~~Spec 12P—3rd Edition (Reaffirmed 2008):~~

~~Specification for Fiberglass Reinforced Plastic Tanks~~

Reason:

The only reference to this standard is in Section 5704.2.13.1.5, which is applicable only to underground tanks that are being reinstalled after removal. API-12P is a tank manufacturing standard scoped only to aboveground tanks (from the summary description of the standard provided on API's Web site: "Tanks covered by this specification are intended for aboveground and atmospheric pressure service." Since the current reference is out of scope with the standard (underground reinstallation vs. aboveground new), it is recommended that the reference and the standard be deleted. IFC Section 5704.2.7 defers tank construction requirements to NFPA 30, and if a reference to API-12P is desired, that should be taken to NFPA 30.

Cost Impact

The code change proposal will not increase or decrease the cost of construction .

Removal of a reference to a standard that is outside of its applicable scope, so technically not allowed anyway.

Internal ID: 2125

F308-18

IFC: 5704.3.1.1

Proponent: Jonathan Roberts, UL LLC, representing UL LLC (jonathan.roberts@ul.com)

2018 International Fire Code

Revise as follows:

5704.3.1.1 ~~Approved~~ Listed containers. ~~Only approved containers~~ Containers and portable tanks shall be ~~used~~ listed in accordance with UL 30 or UL 1313.

Reason:

This proposal provides clarification and guidance to the fire code official for the safety of portable containers by replacing the requirement for "approved" to the appropriate listing standards that correlate with NFPA 30.

Cost Impact

The code change proposal will not increase or decrease the cost of construction .

This proposal simply changes requirement from "approved" containers to the listing requirements to the appropriate testing standards.

Internal ID: 232

F309-18

IFC: 5704.3.7 (New), 5704.3.7.1 (New), 5704.3.7.2 (New), 5704.3.7.3 (New), 5704.3.7.4 (New), 5704.3.7.5 (New), TABLE 5704.3.7.1(1) (New), Table 5704.3.7.3(1) (New)

Proponent: Leslie Townzen, Townzen & Associates, Inc, representing Medline Industries, Inc (les@townzen-consulting.com)

2018 International Fire Code

Add new text as follows:

5704.3.7 Storage of Alcohol-Based Hand Sanitizers. Storage of alcohol-based hand sanitizers classified as Class I or II Flammable Liquids in Group S Occupancy warehouse uses shall be in accordance with Sections 5704.3.7.1 through 5704.3.7.5.

5704.3.7.1 Maximum Allowable Quantity . For occupancies other than Group S wholesale uses that are less than 80,000 sq. ft. in size, indoor storage of alcohol based hand sanitizers shall not exceed the maximum allowable quantities per control area indicated in Table 5003.1(1).
For Group S Occupancy Warehouses greater than 80,000 sq. ft., indoor storage of alcohol based hand sanitizers shall not exceed the maximum allowable quantities per control area indicated in Table 5704.3.7.1(1).

5704.3.7.2 Container type. Containers for alcohol based hand sanitizers shall be of any material.

5704.3.7.3 Container capacity. Containers for sanitizers shall not exceed a capacity of 1 gallons (3.79 L).

Exception: Metal containers not exceeding 55 gallons (208 L) are allowed to store up to the maximum allowable quantity per control area of Class IB and IC liquids in a control area in accordance with tables 5003.1(1) or Table 5704.3.7.1(1). The building shall be equipped throughout with an approved automatic sprinkler system in accordance with Tables 5704.3.6.3(4) through 5704.3.6.3(8) The containers shall be provided with plastic caps without cap seals and shall be stored upright. Containers shall not be stacked or stored in racks and shall not be stored in areas open to the public.

5704.3.7.4 Fire protection and storage arrangements. Fire protection and container storage arrangements shall be in accordance with Table 5704.3.7.3(1) or the following:

1. Storage on shelves shall not exceed 6 feet (1829 mm) in height, and shelving shall be metal.
2. Storage on pallets or in piles greater than 4 feet 6 inches (1372 mm) in height, or where the ceiling exceeds 18 feet (5486 mm) in height, shall be protected in accordance with Table 5704.3.6.3(4), and the storage heights and arrangements shall be limited to those specified in Table 5704.3.6.3(2).
3. Storage on racks greater than 4 feet 6 inches (1372 mm) in height, or where the ceiling exceeds 18 feet (5486 mm) in height shall be protected in accordance with Table 5704.3.6.3(5), and the storage heights and arrangements shall be limited to those specified in Table 5704.3.7.3(1). Combustible commodities shall not be stored above flammable and combustible liquids.

5704.3.7.5 Storage plan. Where required by fire the code official, aisle and storage plans shall be submitted in accordance with Chapter 50.

TABLE 5704.3.7.1(1)

MAXIMUM ALLOWABLE QUANTITY PER CONTROL AREA OF ALCOHOL BASED HAND SANITIZERS IN GROUP S WAREHOUSE OCCUPANCIES MORE THAN 80,000 SQ. FT., a, b

<u>Type of Liquid</u>	MAXIMUM ALLOWABLE QUANTITY PER CONTROL AREA (gallons)	
	<u>Sprinklered in accordance with Tables 5704.3.6.3(4) through 5704.3.6.3(8) and Table 5704.3.7.5.1</u>	<u>Sprinklered with ESFR Systems ^e</u>
<u>Class I, II, III</u>	<u>5,000^d</u>	<u>10,000^e</u>

For SI: 1 foot = 304.8 mm, 1 square foot = 0.0929 m², 1 gallon = 3.785 L, 1 gallon per minute per square foot = 40.75 L/min/m².

a. This table shall only apply to Group S warehouse occupancies greater than 80,000 sq. ft. that are classified as Type I or II construction in accordance with the International Building Code.

b. Control areas shall be separated from each other by not less than a 1-hour fire barrier.

c. Where warehouse storage areas exceed 80,000 square feet in area and such storage area is not accessible to the public, the maximum allowable quantities are allowed to be increase by 2 percent for each 1,000 square feet of area in excess of 80,000 square feet, up to a maximum of 100 percent of the table amounts. A control area separation is not required. The cumulative amounts, including amounts attained by having an additional control area, shall not exceed 20,000 gallons.

e. ESFR automatic sprinkler systems installed in accordance with Section 903.3.1.1.

Table 5704.3.7.3(1)
STORAGE HEIGHTS AND ARRANGEMENTS

<u>Type of Sanitizer</u>	<u>Non-Sprinklered Area</u> <u>(feet)</u>	<u>Sprinklered Area^a</u> <u>(feet)</u>	<u>Sprinklered with in-rack</u> <u>protection^a</u> <u>(feet)</u>	
<u>Class IB</u>	<u>4</u>	<u>8</u>	<u>12</u>	
<u>Class IC</u>	<u>4</u>	<u>8</u>	<u>12</u>	
<u>Class II</u>	<u>6</u>	<u>12</u>	<u>16</u>	

a. When the building is protected by an ESFR automatic sprinkler system designed in accordance with Section 903.3.1.1 for Group A Plastics and high hazard occupancies.

Reason:

This code change is being submitted for the second time. During the first attempt, we received several comments on some of the short falls for the change. The most common comment was that there was no fire test data to support the changes that we were proposing.

As a result, the code changes you see now is vastly different that what we proposed last cycle. We conducted both ½ and full fire pallet testing of the product. This test conducted by Southwest Research Institute on July 11, 2017. The test results are attached for your review.

We first tested the product in a ½ pallet configuration because we did not know how the product was going to react. After seeing the results of the first test, we felt confident on doing a full pallet test.

As you can see by the test results even for the full pallet test, the heat release rate (HRR) was relatively low, even at the peak it was only 1857kW and that was at 13minutes and 20 seconds into the test.

As shown in the pictures during the fire test and the summary of the test, this product did not act like what we thought it would for being a Class I Flammable Liquid classification. The fire was not violent by any means because of the alcohol content. This fire did not have the violent burn rate and reaction that we typically see with a flammable liquids fire.

I sent the fire test results to the two-main people who had opposition of the code change, and in our discussions, it was agreed that the test provided enough information based on the results that a full-scale test was not needed.

We discussed how could we fit the change into the code, and it was decided that sanitizers would have its own section instead of trying to modify the code in the Group M section.

So, what you have now is a new section with requirement that would allow for increased MAQ amounts in Group S, warehouse occupancies with fire protection and size limitations.

Background:

The hand sanitizers are not intended for consumption; therefore, the exemption permitted for alcoholic beverages with alcohol contents greater than 50% does not apply (though hand sanitizers are no more flammable than alcoholic beverages). These materials do comply with the individual container limitation, though they do not technically fall into the category for exemption.

Until recently, sanitizer products have not been in similar demand to alcoholic beverages. As such, the issue of storing the materials practically has only recently been realized. The most recent editions of the Codes have started addressing hand sanitizers including an exception from the hazardous materials provisions for wall mounted hand rubs containing alcohol. However, the storage of these materials is not specifically addressed in the latest editions of the codes.

The quantity limitations per the "S" occupancy have simply not caught up with those allowed for wholesale retail spaces compared to other occupancies. These spaces are permitted to store up to 30,000 gallons of flammable liquids in accordance with Table 5704.3.4.1 of the Fire Code in lieu of 240 gallons in accordance with the Table 5003.1.1(1) of the Fire Code.

The logic behind the increased capacity for retail operations is based upon the inherent need for retail occupancies to have larger quantities of stock available for purchase to operate effectively; this is exactly the same reason that large Group S warehouses need this increase to be able to operate in an effective manner.

The only significant difference between a traditional wholesale retail store and the typical Group S facility is the restriction of public access. However, by restricting public access the occupant load of the space is lower than the occupant load of a traditional retail space. The occupant load factor used to determine the occupant load for a retail space on grade is 30 square feet per person, which is ten times denser than the occupant load factor associated with storage (300 square feet per person). As such, the calculated occupant load of a retail space is ten times greater than a storage space.

By restricting public access to the space, only staff is permitted in the storage area. Warehouse employees are trained to respond appropriately to a fire event and are familiar with the layout of the space, including aisles and exit paths. This combined with a lower occupant load significantly decreases the egress time for the occupants of the facility. As such, the storage space presents a lower life safety hazard than a traditional wholesale retail establishment. Property loss prevention is a larger factor than in a retail facility.

As stated above, although the storage space presents a lesser hazard to life than a retail establishment, a wholesale retailer is permitted to have a maximum of 30,000 gallons of Class IB and IC liquids. The maximum permitted quantity is ten times greater than the limit proposed for Group S warehouse facility.

The Building and Fire Codes recognize that to operate certain types of establishments, it is necessary to maintain a stock of specific products in excess of the maximum permitted control area quantities.

Retail establishments that sell alcoholic beverages require larger quantities of beverages than permitted for control areas.

To permit the sale of these materials, the codes exempt alcoholic beverages in retail and storage uses when packaged in individual containers not exceeding 1.3 gallons, regardless of the actual alcohol content. This includes alcoholic beverages that contain alcohol content of up to 90%.

Medicines, cosmetics, and foodstuff with an alcohol content of less than 50% are exempt as well.

However, medicines, cosmetics, and foodstuffs containing more than 50% alcohol are not exempt from the quantity limitation. The hand sanitizers have an alcohol content of more than 50%. The hand sanitizers are not intended for consumption; therefore, the exemption permitted for alcoholic beverages with alcohol contents greater than 50% does not apply (though hand sanitizers are no more flammable than alcoholic beverages). Some supplies materials do comply with the individual container limitation, though they do not technically fall into the category for exemption.

Until recently, sanitizer products have not been in similar demand to alcoholic beverages. As such, the issue of storing the materials practically has only recently been realized. The most recent editions of the Codes have started addressing hand sanitizers including an exception from the hazardous materials provisions for wall mounted hand rubs containing alcohol. However, the storage of these materials is not specifically addressed in the latest editions of the codes.

Cost Impact

The code change proposal will not increase or decrease the cost of construction .

Impact will be based on individual needs and their own decision if they want to store more than the 240 gallons in their warehouse.

Internal ID: 1760

F310-18

IFC: 2301.1, 2312, 2312.1, 2312.1.1, 2312.2, 2312.3, 2312.3.1, 2312.3.2, 2312.3.3, 2312.4, 2312.4.1, 2312.4.2, 2312.5, 2312.5.1, 2312.5.2, 2312.5.3, 2312.5.4, 2312.6, 2312.6.1, 2312.6.2, 2312.6.3

Proponent: Michael O'Brian, Chair, representing FCAC (FCAC@iccsafe.org)

2018 International Fire Code

Revise as follows:

2301.1 Scope. Automotive motor fuel-dispensing facilities, marine motor fuel-dispensing facilities, fleet vehicle motor fuel-dispensing facilities, aircraft motor-vehicle fuel-dispensing facilities ~~and~~ and repair garages, and on-demand mobile fueling shall be in accordance with this chapter and the International Building Code, International Fuel Gas Code and International Mechanical Code. Such operations shall include both those that are open to the public and private operations.

~~SECTION 5707.2~~2312 ON-DEMAND MOBILE FUELING OPERATIONS

~~5707.1~~2312.1 **General.** On-demand mobile fueling operations that dispense Class I, II and III liquids into the fuel tanks of motor vehicles shall comply with Sections ~~5707.1~~2312.1 through ~~5707.6.3~~2312.6.3.

Exception: Fueling from an *approved* portable container in cases of an emergency or for personal use.

~~5707.1~~2312.1.1 **Approval required.** Mobile fueling operations shall not be conducted without first obtaining a *permit* and approval from the *fire code official*. Mobile fueling operations shall occur only at *approved* locations.

~~5707.2~~2312.2 **Mobile fueling vehicle.** . An on-demand mobile fueling vehicle shall be one of the following:

1. A vehicle that has chassis-mounted tanks or containers where the aggregate cargo capacity does not exceed 1200 gallons (4592 L). A mobile fueling vehicle with a mounted *tank* in excess of 110 gallons (415 L) shall comply with the requirements of Section 5706.6, Section ~~5707.2~~2312 and NFPA 385.
2. A vehicle that carries a maximum of 60 gallons (227 L) of motor fuel in metal safety cans *listed* in accordance with UL 30 or other *approved* metal containers, each not to exceed 5 gallons (19 L) in capacity. Containers shall be secured to the mobile fueling vehicle except when in use.

The mobile fueling vehicle shall comply with all local, state and federal requirements. The mobile fueling vehicle and its equipment shall be maintained in good repair.

~~5707.3~~2312.3 **Required documents.** Documents developed to comply with Sections ~~5707.3.1~~2312.3.1 through ~~5707.3.3~~2312.3.3 shall be updated as necessary by the *owner* of the mobile fueling operation and shall be maintained in compliance with Section 108.3.

~~5707.3~~2312.3.1 **Safety and emergency response plan.** Mobile fueling operators shall have an *approved* written safety and emergency response plan that establishes policies and procedures for fire safety, spill prevention and control, personnel training and compliance with other applicable requirements of this code.

~~5707.3~~2312.3.2 **Training records.** Mobile fueling vehicles shall be operated only by designated personnel who are trained on proper fueling procedures and the safety and emergency response plan. Training records of operators shall be maintained.

~~5707.3~~2312.3.3 **Site plan.** Where required by the *fire code official*, a site plan shall be developed for each location at which mobile fueling occurs. The site plan shall be in sufficient detail to indicate: all buildings, structures, *lot lines*, property lines and appurtenances on site and their use or function; all uses adjacent to the *lot lines* of the site; fueling locations, the locations of all storm drain openings and adjacent waterways or wetlands; information regarding slope, natural drainage, curbing, impounding and how a spill will be kept on the site property; and the scale of the site plan.

~~5707.4~~2312.4 **Mobile fueling areas.** Mobile fueling shall not occur on public streets, *public ways* or inside *buildings*. Fueling on the roof level of parking structures or other *buildings* is prohibited.

~~5707.4~~2312.4.1 **Separation.** Mobile fueling shall not take place within 25 feet (7620 mm) of buildings, property lines or combustible storage.

Exception: The *fire code official* shall be authorized to decrease the separation distance for dispensing from metal

safety cans or other *approved* metal containers in accordance with Section ~~5707.2.2312.2.~~

Where dispensing operations occur within 15 feet (4572 mm) of a storm drain, an *approved* storm drain cover or an *approved* equivalent method that will prevent any fuel from reaching the drain shall be used.

~~5707.4.2312.4.2~~ Sources of ignition. Smoking, open flames and other sources of ignition shall be prohibited within 25 feet (7620 mm) of fuel dispensing activities. Signs prohibiting smoking or open flames within 25 feet (7620 mm) of the vehicle or the point of fueling shall be prominently posted on the mobile fueling vehicle. The engines of vehicles being fueled shall be shut off during fueling.

~~5707.5.2312.5~~ Equipment. Mobile fueling equipment shall comply with Sections ~~5707.5.12312.5.1~~ through ~~5707.5.4.2312.5.4.~~

~~5707.5.12312.5.1~~ Dispensing hoses and nozzles. Where equipped, the dispensing hose shall not exceed 50 feet (15 240 mm) in length. The dispensing nozzles and hoses shall be of an *approved* and *listed* type.

~~5707.5.2312.5.2~~ Fuel limit. Mobile fueling vehicles shall be equipped with a fuel limit switch set to a maximum of 30 gallons (116 L) and a nozzle or other *approved* device that, when activated, immediately causes flow of fuel from the mobile fueling vehicle to cease.

~~5707.5.32312.5.3~~ Fire extinguisher. An *approved* portable fire extinguisher complying with Section 906 with a minimum rating of 40-B:C shall be provided on the mobile fueling vehicle with signage clearly indicating its location.

~~5707.5.42312.5.4~~ Spill kit. Mobile fueling vehicles shall contain a minimum 5-gallon (19 L) spill kit of an *approved* type.

~~5707.6.2312.6~~ Operations. Mobile fueling vehicles shall be constantly attended during fueling operations with brakes set and warning lights in operation. Mobile fueling vehicles shall not obstruct emergency vehicle access roads.

~~5707.6.12312.6.1~~ Dispensing hose. Where equipped, mobile fueling vehicles shall be positioned in a manner to preclude traffic from driving over the dispensing hose. The dispensing hose shall be properly placed on an *approved* reel or in an *approved* compartment prior to moving the mobile fueling vehicle.

~~5707.6.2312.6.2~~ Drip control. Operators shall place a drip pan or an absorbent pillow under the nozzle and each fuel fill opening prior to and during dispensing operations to catch drips.

~~5707.6.3.2312.6.3~~ Spill reporting. Spills shall be reported in accordance with Section 5003.3.1.

Reason:

This proposal places the mobile fueling regulations into Chapter 23, the chapter governing motor fuel dispensing facilities and repair garages. When the language was adopted into the 2018 IFC, the scope of Chapter 23 was not able to be changed during public comment, so mobile fueling regulations were included into Chapter 57, Flammable and Combustible Liquids. The scope of chapter 23 has been revised to include on-demand mobile fueling.

This proposal is submitted by the ICC Fire Code Action Committee (FCAC). The FCAC was established by the ICC Board of Directors to pursue opportunities to improve and enhance assigned International Codes with regard to fire safety and hazardous materials in new and existing buildings and facilities and the protection of life and property in wildland urban interface areas. In 2017 the Fire-CAC has held 3 open meetings. In addition, there were numerous conference calls, Regional Work Group and Task Group meetings for the current code development cycle, which included members of the committees as well as any interested parties, to discuss and debate the proposed changes. Related documentation and reports are posted on the FCAC website at: <https://www.iccsafe.org/codes-tech-support/cs/fire-code-action-committee-fcac/>

Cost Impact

The code change proposal will not increase or decrease the cost of construction .

This proposal has no regulatory change, editorial only.

Internal ID: 255

F311-18

IFC: 5707.1, 5707.2, 5707.3.3, 5707.4, 5707.4.1, 5707.4.3 (New), 5707.5, 5707.5.1, 5707.5.2 (New), 5707.5.3, 5707.5.4, 5707.5.5, 5707.6.3 (New), 5707.6.4 (New), 5707.6.5 (New), 5707.6.6

Proponent: Michael O'Brian, Chair, representing FCAC (FCAC@iccsafe.org)

2018 International Fire Code

Revise as follows:

5707.1 General. On-demand mobile fueling operations that dispense Class I, II and III liquids into the fuel tanks of motor vehicles shall comply with Sections 5707.1 through ~~5707.6.3, 5707.6.6.~~

Exception: Fueling from an *approved* portable container in cases of an emergency or for personal use.

5707.2 Mobile fueling vehicle. An on-demand mobile fueling vehicle shall be one of the following:

1. A ~~tank vehicle in accordance with NFPA 385~~ that has chassis-mounted tanks ~~or containers~~ where the aggregate cargo capacity does not exceed ~~1200-1600~~ gallons (~~4592-6057~~ L).
2. A ~~mobile fueling vehicle with a mounted tank in excess of one or more chassis-mounted tanks or chassis-mounted containers that do not exceed 110 gallons (415 L) individual capacity and having an aggregate capacity that does not exceed 1200 gallons (4592 L) shall comply with the requirements of Section 5706.6, Section 5707 and NFPA 385.2 or the weight capacity of the vehicle in accordance with DOT.~~
3. A vehicle that carries a maximum of 60 gallons (227 L) of motor fuel in metal safety cans listed in accordance with UL 30 or other approved metal containers, each not to exceed 5 gallons (19 L) in capacity. ~~Containers shall be secured to the mobile fueling vehicle except when in use.~~
4. The mobile fueling vehicle shall comply with all local, state and federal requirements.
5. Mobile fueling vehicles with a chassis-mounted tank in excess of 110 gallons (415 L) shall comply with the requirements of Section 5706.6, Section 5707, and NFPA 385.
6. The mobile fueling vehicle and its equipment shall be maintained in good repair.
7. Safety cans and approved metal containers shall be secured to the mobile fueling vehicle except when in use.
8. Fueling a motor vehicle from tanks or containers mounted in a trailer connected to a mobile fueling vehicle shall be prohibited.

5707.3.3 Site plan. Where required by the *fire code official*, a site plan shall be developed for each location at which mobile fueling occurs. The site plan shall be in sufficient detail to indicate the following: ~~all~~

1. All buildings ~~, and structures;~~
2. Lot ~~lot~~ lines ~~or~~, property lines ~~and appurtenances~~
3. Electric car chargers
4. Solar photovoltaic parking lot canopies
5. Appurtenances on site and their use or function; ~~all~~
6. All uses adjacent to the lot lines of the site; ~~fueling locations, the locations~~
7. Fueling locations
8. Locations of all storm drain openings, bioswales and adjacent waterways or wetlands; ~~information~~
9. Information regarding slope, natural drainage, curbing, impounding ~~and how~~
10. How a spill will be kept on the site property; ~~and the scale~~
11. Scale of the site plan.

5707.4 Mobile fueling areas. ~~Mobile fueling~~ The mobile fueling vehicle and point of connection of the vehicle being fueled shall not occur on public streets, *public ways* or inside *buildings*. Fueling on the roof level of parking structures or other *buildings* is prohibited.

5707.4.1 Separation. ~~Mobile fueling~~ The point of connection of the vehicle being fueled shall not take place within 25 feet (7620 mm) of buildings, lot lines, property lines or combustible storage. Mobile fueling vehicles shall not park within 10 feet (3048 mm) of buildings, lot lines, property lines, or combustible storage.

Exception-Exceptions:

1. The fire code official shall be authorized to decrease the separation distance for dispensing from metal safety cans or other approved metal containers in accordance with Section 5707.2.
2. The point of fueling shall not take place within 10 feet (3048 mm) of buildings, lot lines, property lines, or combustible storage when the mobile fueling vehicle has an approved vapor recovery system or is servicing vehicles with on board refueling vapor recovery.

Where dispensing operations occur within 15 feet (4572 mm) of a storm drain or bioswale, an *approved* storm drain cover or an *approved* equivalent method that will prevent any fuel from reaching the drain or bioswale shall be used.

Add new text as follows:

5707.4.3 Electrical equipment. Mobile fueling shall not occur within 20 feet of electrical equipment located within 18 inches of the ground unless such electrical equipment is rated for Class I, Division 2 hazardous locations in accordance with the National Electrical Code.

Revise as follows:

5707.5 Equipment. Mobile fueling equipment shall comply with Sections 5707.5.1 through ~~5707.5.4~~ 5707.5.5.

5707.5.1 Dispensing hoses and nozzles. Where equipped, the dispensing hose shall not exceed 50 feet (15 240 mm) in length. The dispensing nozzles and hoses shall be of an *approved* and *listed* type. Where metal-to-metal contact cannot be made between the nozzle and the fuel fill opening, then a means for bonding the mobile fueling vehicle to the motor vehicle shall be provided and employed during fueling operations.

Add new text as follows:

5707.5.2 Break-away device. A listed break-away device shall be provided at the nozzle.

Exception: Mobile fueling vehicles equipped with an approved brake interlock tied to the nozzle holder that prohibits movement of the mobile fueling vehicle when the nozzle is removed from its holder or tied to the delivery of fuel that prevents activation of the pumping system.

Revise as follows:

~~**5707.5.2**~~ ~~**5707.5.3 Fuel Shut off valve and fuel limit.**~~ Mobile fueling vehicles shall be equipped with a listed shutoff valve assembly and a fuel limit switch set to a maximum of 30 gallons (116 L) and a nozzle or other approved device that, when activated, immediately causes flow of fuel from the mobile fueling vehicle to cease.

~~**5707.5.3**~~ **5707.5.4 Fire extinguisher.** An *approved* portable fire extinguisher complying with Section 906 with a minimum rating of ~~40-4-A:80-B:C~~ shall be provided on the mobile fueling vehicle with signage clearly indicating its location.

~~**5707.5.4**~~ **5707.5.5 Spill kit.** Mobile fueling vehicles shall contain a minimum 5-gallon (19 L) spill kit of an *approved* type.

Add new text as follows:

5707.6.3 Safety cones. Safety cones or other visual barriers shall be employed as warning devices to highlight the vehicle fueling area.

5707.6.4 Vehicle lights. The mobile fueling vehicle flasher lights shall be in operation while dispensing operations are in progress.

5707.6.5 Nighttime deliveries. Nighttime deliveries shall only be made in areas deemed adequately lighted by the fire code official.

~~**5707.6.3**~~ **5707.6.6 Spill reporting.** Spills shall be reported in accordance with Section 5003.3.1.

Reason:

5707.1 This section is revised to reflect the added subsections to 5707.6.

5707.2 This section has been reorganized for clarification and to better emphasize the three distinct mobile fueling vehicles: 1) a tank vehicle as defined in NFPA 385, 2) a vehicle with portable containers (not cargo tanks or portable tanks due to size) mounted in the back, and 3) motor vehicles transporting portable safety cans and metal containers.

The 1,200 gallon size threshold for mobile fueling tank vehicles was an arbitrary value chosen based on the specs of already existing, custom-designed vehicles that were in operation at the time the mobile fueling language was put in the Code. Operations have shown that a ~1,550 gallon total tank capacity allows the right ratio and total volume of different grades of gasoline, significantly reducing the number of required tank vehicle reloadings. This proposal increases the allowed capacity only of tank vehicles, which are required to conform to stringent DOT and NFPA 385 requirements.

5707.3.3. Showing the location of electric car chargers and solar photovoltaic parking lot canopies on the site map assists the fire code official identify potential sources of ignition since generally these systems use ordinary electrical not rated for hazardous locations. The mobile fueling operator also needs to be aware of where these systems exist so that appropriate setbacks can be maintained during fueling. Also, identifying bioswales on the site map is important since bioswales should be protected from liquid intrusions in a manner similar to storm drain openings.

5707.4 This clarifies the language of the section to make it consistent with section 5707.4.2 and the original concern. The primary safety concern was the fumes from the fuel dispensing, and the separation requirement was used to address the hazard.

5707.4.1. Providing clarification that both the mobile fueling vehicle and the point of fuel transfer at the receiving vehicle are intended to be kept 25 feet from buildings, property lines and combustible storage. Also, adding specific text to require bioswales to be protected from liquid intrusion since bioswales present a direct path for liquids to reach the environment.

5707.4.3. Industry position is that unrated electrical equipment is not an ignition source and thus not subject to the setback requirement of 5707.4.2. This proposal establishes setbacks for unrated electrical equipment that may be in the vicinity of fueling operations such as electric car chargers and solar photovoltaic car canopies. The intent is to ensure that where unrated electrical systems exist and is located within 18 inches of the ground that fueling operations are kept at least 20 feet from the electrical equipment. This setback is consistent with requirements in Chapter 57 and NFPA 30 for flammable liquids.

5707.5.1. Adds a requirement for bonding of the fueling vehicle to the vehicle being fueled during fueling to minimize static. This is generally accomplished by having fuel hose with an integral bond wire and newer vehicles have a bond wire at the fill opening. Consistent with NFPA 30A requirement.

5707.5.2. Adding a new requirement for a breakaway device or approved brake interlock to ensure if the mobile fueling vehicle drives away with the hose and nozzle engaged in the receiving vehicle that the hose/nozzle will disconnect and prevent minimize spills. A similar provision appears in NFPA 30A.

5707.5.3. Clarifying that in addition to the fuel limit switch that the system shall include a shutoff valve assembly that activates upon activation of the switch. A similar provision appears in NFPA 30A.

5707.5.4. Increasing the size of the portable fire extinguisher carried on the mobile fueling vehicle to 4A:80BC to enable extinguishment of a larger pool fire. Increased size is consistent with NFPA 30A.

5707.5.5 This section has been renumbered from 5707.4.

5707.6.3. Adds a requirement for safety cones or other barrier to be in place during fueling as a warning to pedestrians and other vehicles. Consistent with NFPA 30A requirement.

5707.6.4. Adds a requirement that the mobile fueling vehicle flasher lights be on during fueling operations as a warning to pedestrians and other vehicles. Consistent with NFPA 30A requirement.

5707.6.5 Adds a requirement that nighttime deliveries have adequate lighting is prudent and good practice so that all equipment including emergency equipment can be seen and easily accessed. Nighttime deliveries are common in this industry. This new provision is consistent with NFPA 30A requirement.

5707.6.6 This section has been renumbered from 5707.6.3.

This proposal is submitted by the ICC Fire Code Action Committee (FCAC). The FCAC was established by the ICC Board of Directors to pursue opportunities to improve and enhance assigned International Codes with regard to fire safety and hazardous materials in new and existing buildings and facilities and the protection of life and property in wildland urban interface areas. In 2017 the Fire-CAC has held 3 open meetings. In addition, there were numerous conference calls, Regional Work Group and Task Group meetings for the current code development cycle, which included members

of the committees as well as any interested parties, to discuss and debate the proposed changes. Related documentation and reports are posted on the FCAC website at: <https://www.iccsafe.org/codes-tech-support/cs/fire-code-action-committee-fcac/>

Bibliography:

2018 edition NFPA 30A, Code for Motor Fuel Dispensing Facilities and Repair Garages

www.nfpa.org/30A

Cost Impact

The code change proposal will not increase or decrease the cost of construction .

This proposal will have no cost impact on construction. This proposal addresses operational concerns of on-demand mobile fueling provides clarification and reorganization of existing regulations of what the mobile vehicle is. Several new provisions (sections 5707.6.3 - 5707.6.5) are included for correlation with NFPA 30A.

Internal ID: 254

F312-18

IFC: 5707.1.1, 5707.3.3

Proponent: Scott Hempy, Filld, Inc., representing Filld, Inc. (scott@filld.co)

2018 International Fire Code

Revise as follows:

5707.1.1 Approval required. Mobile fueling operations shall not be conducted without first obtaining a *permit* and approval from the *fire code official*. Mobile fueling operations shall occur only at *approved locations or areas*.

5707.3.3 Site plan. Where required by the *fire code official*, a site plan shall be developed for each location or area at which mobile fueling occurs. The site plan shall be in sufficient detail to indicate: all buildings, structures, *lot lines*, property lines and appurtenances on site and their use or function; all uses adjacent to the *lot lines* of the site; fueling locations, the locations of all storm drain openings and adjacent waterways or wetlands; information regarding slope, natural drainage, curbing, impounding and how a spill will be kept on the site property; and the scale of the site plan.

Reason:

Reason Statement for Sections 5707.1.1 and 5707.3.3

Mobile Fueling Locations or Areas

Requiring approval of each individual fuel delivery location imposes an undue burden on fire code officials that is not proportionate to the level of risk posed by operations at such locations. Moreover, on a practical basis, because the fee amount outweighs the value of the service at many individual locations with lower or less consistent demand (e.g., small businesses or residential locations with a single vehicle) it becomes prohibitive.

This industry supported proposal solves this problem by allowing a fire code official to approve mobile fueling by permitted mobile fueling operators in areas determined safe, all in accordance with a site plan submitted by a mobile fueling operator detailing how it will safely provide mobile fueling services in full compliance with the code. This will reduce costs and staffing needs for the fire services, while still maintaining a high level of safety.

For over a century, companies have been safely delivering diesel fuel and propane to millions of residences throughout the United States. According to the Energy Information Administration, in 2007, 8.1 million homes used heating oil as their main source of fuel necessitating between 32 million and 40 million deliveries a year. In contrast, mobile fueling of vehicles at residences involves the transfer of substantially less fuel entailing significantly reduced overall risk. Trained professionals operating in full compliance with the procedures and equipment requirements set forth in Section 5707 can safely transfer fuel to vehicles in residential areas. Limiting the fire code officials' authority to permitting locations only on an individual basis unnecessarily drives up the costs and time required of fire code officials and limits the ability of the public to realize the full benefits of mobile fueling.

The use of an area-wide permitting scheme is common practice in many other regulatory spaces. For example, the U.S. Environmental Protection Agency (EPA) may issue a general National Pollution Discharge Elimination System permit to cover a group of dischargers with similar qualities within a given geographical location. As indicated by the EPA, general permits "offer a cost-effective option for permitting agencies because of the large number of facilities that can be covered under a single permit" (see <https://www.epa.gov/npdes/about-npdes#types>). This is precisely the type of balanced permitting scheme that should be used in the context of mobile fueling.

Bibliography:

None

Cost Impact

The code change proposal will decrease the cost of construction .

These changes should not adversely affect the cost of enforcing the Code. In some cases, the changes may reduce local fire code official costs, by allowing for a fire code official to approve larger areas, as opposed to each specific location.

Internal ID: 1531

F313-18

IFC: 5707.3.3

Proponent: Andrew Klein, representing Booster Fuels (andrew@asklein.com)

2018 International Fire Code

Revise as follows:

5707.3.3 Site plan. ~~Where required by the~~ The fire code official, has the authority to require a site plan shall be developed for each location at or area in which mobile fueling occurs. The ~~Where the fire code official requires a site plan, the plan shall be developed by the mobile fueling operator and shall be in sufficient detail to ensure safety and the protection of the environment during fueling operations. The fire code official is authorized to require the site plan~~ to indicate: all buildings, structures, *lot lines*, property lines and appurtenances on site and their use or function; all uses adjacent to the *lot lines* of the site; fueling locations, the locations of all storm drain openings and adjacent waterways or wetlands; information regarding slope, natural drainage, curbing, impounding and how a spill will be kept on the site property; and the scale of the site plan.

Reason:

This proposal clarifies the intent of a site plan and provides the fire code official the ability to use a graded approach in determining what must be indicated. The previous language, which this proposal fixes, provided the fire code official with a binary decision as to whether or not to require a site plan. If a site plan was required, the language left no room to apply a graded approach to what must be indicated on the site plan based on the features of the site or group of sites. Such rigid language poses a liability risk to jurisdictions that approve a site plan that does not indicate the entirety of objects in the list. This proposal keeps the list as a guide but gives the authority back to the fire code official to determine what must be indicated in the site plan.

Cost Impact

The code change proposal will not increase or decrease the cost of construction .

This code change proposal clarifies the intent of the site plan, should one be required. Since site plans are not always required, this code change proposal has no effect on the cost of operations if a fire code official does not require a site plan. When a fire code official chooses to require a site plan, this code change proposal MAY have the potential to slightly decrease the cost of operations if a site plan with fewer details is sufficient and acceptable. Because many jurisdictions do not currently require the entirety of objects in the list, there overwhelmingly will be no change in the cost of operations even when a site plan is required.

Internal ID: 1834

F314-18

IFC: 5707.4

Proponent: Andrew Klein, representing Booster Fuels (andrew@asklein.com)

2018 International Fire Code

Revise as follows:

5707.4 Mobile fueling areas. Mobile fueling shall not occur on public streets, *public ways* or inside *buildings*. Fueling on the roof level of parking structures or other *buildings* is prohibited unless adequate and direct access from grade-level is provided as determined by the fire code official.

Reason:

There are some sites where a building or underground parking structure is below a grade-level parking lot. Fueling at such a location does not hinder emergency vehicle access, and fueling may be performed safely. This proposal provides the fire code official the ability to permit fueling at such locations when adequate emergency vehicle access is provided.

Cost Impact

The code change proposal will not increase or decrease the cost of construction .

This code change proposal simply clarifies where mobile fueling is permitted.

Internal ID: 1832

F315-18

IFC: 5707.4

Proponent: Bob Morgan, Fort Worth Fire Department, representing Fort Worth Fire Department

2018 International Fire Code

Revise as follows:

5707.4 Mobile fueling areas. Mobile fueling shall not occur on public streets, *public ways* or inside *buildings*. Fueling on the roof level of parking structures or other *buildings* is prohibited.

Mobile fueling sites shall be restricted to commercial, industrial, governmental, or manufacturing, where the parking lot is primarily intended for employee vehicles. Mobile fueling shall be conducted for fleet fueling or employee vehicles only, not the general public. Commercial sites shall be restricted to office-type or similar occupancies that are not primarily intended for use by the public.

Reason:

The general public does not expect a hazardous operation to be occurring in a typical parking lot or for a fuel truck to be traversing such parking lot, temporarily fueling a vehicle, and moving on to the next area in the parking lot to fuel the next vehicle. Vehicular accidents occur in parking lots on a regular basis, but the presence of a fuel truck, especially one in the process of fueling a vehicle greatly adds to the potential risk involved in such accidents. By restricting such operations to the occupancies in question, the employees of the business may be adequately notified to expect such operations to occur in the parking lot.

Cost Impact

The code change proposal will not increase or decrease the cost of construction .

There is no construction involved in this regard, but this proposed code change would limit the ability of on-demand mobile fuelers to conduct operations in areas frequented by the public.

Internal ID: 923

F316-18

IFC: 5707.4, 5707.4.1 (New)

Proponent: Scott Hempy, representing Filld, Inc. (scott@filld.co)

2018 International Fire Code

Revise as follows:

5707.4 Mobile fueling areas. Where mobile fueling shall not occur on public streets, or public ways fueling operations shall comply with all of the following: ~~or inside buildings. Fueling~~

The mobile fueling vehicle shall have an approved vapor recovery system or shall only service vehicles with on-board refueling vapor recovery;

The mobile fueling vehicle shall comply with all applicable parking and traffic vehicle laws;

Mobile fueling activities may not obstruct vehicular or pedestrian traffic.

The fire code official may also limit the occurrence of mobile fueling on public streets and public ways to certain time periods of the day when pedestrian and vehicular traffic is substantially reduced. ~~on the roof level of parking structures or other buildings is prohibited.~~

5707.4.1 Prohibited locations. Mobile fueling shall not occur inside or on the roof level of buildings or parking structures.

Reason:

These changes in Sec. 5707.4 allows for mobile fueling to occur on public streets or public ways only when allowed by the fire code official and only when specified conditions are met.

The recently adopted restrictions on mobile fueling on public streets and public ways are motivated by concerns over potential scenarios such as collision with a mobile fueling vehicle or the ignition of gasoline vapors from a nearby ignition source. The proposed modification to the requirements for mobile fueling on public streets and public ways will address these concerns by giving the fire code official discretion to authorize mobile fueling operations in public streets and public ways while ensuring that public safety remains paramount. At the same time, this change will eliminate an unnecessarily restrictive prohibition and allow mobile fueling operations to continue to grow in a safe but reasonable manner.

The mobile fueling vehicle operator must comply with three conditions of fueling to ensure safety while fueling in public ways or public streets. First, identical to the modification of Sec. 5707.4 (Exception 2) proposed by the Fire Code Action Committee, mobile fueling can only occur if an approved vapory recovery mechanism is utilized. Second, all applicable parking laws must be obeyed. Third, similar to the modification of Sec. 5707.6.3 proposed by the FCAC, any temporary obstruction that could be created by a fueling hose or any other mobile fueling equipment must be marked in accordance with applicable industry best practices. The optional imposition of time-of-day restrictions provides yet another rational and simple method for substantially mitigating risk without unreasonably constraining mobile fueling operations.

These changes allow a jurisdiction to exercise its discretion to allow mobile fueling on a public street or public way subject to compliance with stated conditions. For example, a municipality with 'car-sharing' programs, for which mobile fueling is a key service provider, could allow for mobile fueling of street-parked 'car-share' vehicles. This modification enables the fire code official to allow the benefits of mobile fueling to be realized by an important subset of customers — those who can only participate via the use of public streets or public ways, while simultaneously affirming the discretion of the fire code official to ensure that any and all operations will be conducted safely.

Tank vehicle parking in public streets and public ways is already allowed in conjunction with "dispensing activities" in Sec. 5706.6.2.2. The enclosed files demonstrate instances in which fueling from public streets is common practice for many propane and heating oil delivery companies while, in fact, using much larger tank vehicles (not limited at the 1200 gallon mobile fueling threshold). Several jurisdictions (e.g., Oregon) have adopted Sec. 5706 for Class 1 flammable liquids as well - so this application would already apply in those jurisdictions and would create more consistency in the Code. The USDOT 49 CFR allows for mobile fueling trucks to park on public ways and public streets, such that this modification will better harmonize applicable code and provide greater clarity and certainty for all those involved.

The industry is confident that adding this allowance will not compromise safety, will increase the authority of the local fire code official, and will enable mobile fueling to occur in public streets or public ways when and where appropriate.



Bibliography:

None

Cost Impact

The code change proposal will not increase or decrease the cost of construction .

These changes should not adversely affect the cost of enforcing the Code.

Internal ID: 607

F317-18

IFC: 6003.1.3

Proponent: Ellie Klausbruckner, Klausbruckner & Associates, Inc, representing Klausbruckner & Associates, Inc.
(ek@klausbruckner.com)

2018 International Fire Code

Revise as follows:

6003.1.3 Treatment ~~system-highly system—highly~~ toxic liquids. Exhaust scrubbers or other systems for processing vapors of highly toxic liquids shall be provided where a spill or accidental release of such liquids can be expected to release highly toxic vapors indoors at *normal temperature and pressure*. Treatment systems and other processing systems shall be installed in accordance with the International Mechanical Code.

Reason:

Exhaust scrubbers are typically designed to capture vapors indoors. Expecting exhaust scrubbers to be installed outdoors and to capture release of highly toxic vapors is impractical. We believe the original intent of this section is for life safety of occupants inside a building in the event of a release.

Cost Impact

The code change proposal will decrease the cost of construction .

There may be a decrease in cost of construction if this section is misapplied to outdoor storage of highly toxic liquids.

Internal ID: 2353

F318-18

IFC: 6103.2.1.1

Proponent: Bruce Swiecicki, National Propane Gas Association, representing National Propane Gas Association (bswecicki@npga.org)

2018 International Fire Code

Revise as follows:

6103.2.1.1 Use in basement, pit or similar location. LP-gas containers shall not be used in a *basement, pit, an above-grade underfloor space* or similar location where heavier-than-air gas might collect. ~~LP-gas containers shall not be used in an above-grade underfloor space or basement collect~~ unless such location is provided with an *approved* means of ventilation.

Exception: Use with self-contained torch assemblies in accordance with Section 6103.2.1.6.

Reason:

In the current text, the first sentence conflicts with the second sentence because “basement” appears in both. By definition in the IBC, a basement cannot be an above-grade floor space.

It is appropriate to permit cylinders to be used in basements or any floor space where sufficient ventilation is provided. For example, floor maintenance machines, plumber’s pots and forklift trucks powered by propane are frequently used in basements, as well as other floor areas throughout the building.

The building code defines a basement as follows:

[BG] BASEMENT. A story that is not a story above grade plane (see “Story above grade plane”). This definition of “Basement” does not apply to the provisions of Section 1612 for flood loads.

[BG] STORY ABOVE GRADE PLANE. Any story having its finished floor surface entirely above grade plane, or in which the finished surface of the floor next above is:

1. More than 6 feet (1829 mm) above grade plane; or
2. More than 12 feet (3658 mm) above the finished ground level at any point.

[BG] GRADE PLANE. A reference plane representing the average of finished ground level adjoining the building at exterior walls. Where the finished ground level slopes away from the exterior walls, the reference plane shall be established by the lowest points within the area between the building and the lot line or, where the lot line is more than 6 feet (1829 mm) from the building, between the building and a point 6 feet (1829 mm) from the building.

Cost Impact

The code change proposal will increase the cost of construction .

The code change proposal may increase the cost of construction in buildings where the installation or modification of a ventilation system is required to achieve compliance with this paragraph. Otherwise, this code change will neither increase nor decrease the cost of construction.

Internal ID: 2198

F319-18

IFC: 6110.1, 6110.2

Proponent: Bruce Swiecicki, representing National Propane Gas Association (bswecicki@npga.org)

2018 International Fire Code

Revise as follows:

6110.1 ~~Temporarily out of service.~~ Removed from service. LP-gas containers whose use has been temporarily discontinued shall comply with all of the following:

1. Be disconnected from appliance piping.
2. Have LP-gas container outlets, except relief valves, closed or plugged.
3. Be positioned with the relief valve in direct communication with the LP-gas container vapor space.

6110.2 ~~Permanently out of service.~~ Removal from site. LP-gas containers ~~to be placed permanently out of service~~ shall be removed from the site.

Reason:

There is some confusion over the current text between the phrase “temporarily discontinued” and the phrase “interruption of service” in paragraph 406.6.3 of the International Fuel Gas Code. The IFC Handbook commentary clarifies the intent of 6110.1 by stating the following:

When a new LP-gas supplier installs a tank at a customer’s facility, he or she is responsible for ensuring that the previous supplier’s tank is removed from service and safely stored until it can be retrieved.

The commentary for 6110.2 also states:

This provision is an extension of Section 6110.1 and requires that any container placed out of service must be retrieved by its owner.

The intent of the provisions in 6110 is to address containers that have been discontinued from service due to the customer changing propane supply companies. It is common practice for containers that have been disconnected from the fuel gas piping to be stored on site until they are retrieved by the owner of the container, which is typically the previous LP-gas supplier.

The proposed changes to this section will clarify that these provisions apply to a container whose use has been discontinued and will be removed from the site, rather than one in which the fuel gas service is temporarily interrupted, such as may occur at a summer home that is closed after the season ends.

Cost Impact

The code change proposal will not increase or decrease the cost of construction .

This code change proposal does not affect the cost of construction because it addresses the safety issues associated with changing LP-Gas suppliers.

Internal ID: 2211

F320-18

IFC: 6303.2, TABLE 6303.2, 6303.1.1.2, TABLE 6304.1.5(1), TABLE 6304.1.5(2)

Proponent: Ellie Klausbruckner, Klausbruckner & Associates Inc., representing Klausbruckner & Associates, Inc.
(ek@klausbruckner.com)

2018 International Fire Code

Revise as follows:

~~**6303.2-6303.1.4 Class 1 oxidizer storage**~~ **Storage configuration.** The storage configuration of Class 1, 2 and 3 liquid and solid oxidizers shall be as set forth in Table ~~6303.2-6303.1.4.~~

**TABLE 6303.2-6303.1.4
STORAGE OF CLASS 1, 2 and 3 OXIDIZER LIQUIDS AND SOLIDS**

STORAGE CONFIGURATION	LIMITS (feet)		
	Class 1	Class 2	Class 3
Piles			
Maximum width	24	16	12
Maximum height	20	Note c	Note c
Maximum distance to aisle	12	8	8
Minimum distance to next pile	4 ^a	Note a	Note a
Minimum distance to walls	2 ^b	2	4
Maximum quantity per pile	200 tons	MAQ	NA
Maximum quantity per building	No Limit	Note d	Note d

For SI: 1 foot = 304.8 mm, 1 pound = 0.454 kg, 1 ton = 0.907185 metric ton.

- a. The minimum aisle width shall be equal to the pile height, but not less than 4 feet and not greater than 8 feet.
- b. There shall not be a minimum distance from the pile to a wall for amounts less than 9,000 pounds.
- c. Maximum storage height in nonsprinklered buildings is limited to 6 feet. In sprinklered buildings see NFPA 400 for storage heights based on ceiling sprinkler protection.
- d. Maximum quantity per building varies. See Chapter 50 for control areas and MAQs.

~~6303.1.1.2~~6303.1.5 Class 3 liquid and solid oxidizers. Not more than 220 pounds (99 kg) of solid or 22 gallons (83 L) of liquid Class 3 oxidizer is allowed in storage and use where such materials are necessary for maintenance purposes or operation of equipment. The oxidizers shall be stored in *approved* containers and in an *approved* manner.

**TABLE 6304.1.5(1)
STORAGE OF CLASS 2 OXIDIZER LIQUIDS AND SOLIDS**

STORAGE CONFIGURATION	LIMITS		
	Control area storage	Group H occupancy storage	Detached storage
Piles			
Maximum width	16 feet	25 feet	25 feet
Maximum height	Note a	Note a	Note a
Maximum distance to aisle	8 feet	12 feet	12 feet
Minimum distance to next pile	Note b	Note b	Note b
Minimum distance to walls	2 feet	2 feet ^c	2 feet ^c
Maximum quantity per pile	MAQ	100 tons	100 tons
Maximum quantity per building	MAQ	2000 tons	No Limit

For SI: 1 foot = 304.8 mm, 1 pound = 0.454 kg, 1 ton = 0.907185 metric ton.

- a. Maximum storage height in nonsprinklered buildings is limited to 6 feet. In sprinklered buildings see NFPA 400 for storage heights based on ceiling sprinkler protection.
- b. The minimum aisle width shall be equal to the pile height, but not less than 4 feet and not greater than 8 feet.
- c. For protection level and detached storage under 4,500 pounds, there shall not be a minimum separation distance between the pile and any wall.

**TABLE 6304.1.5(2)
STORAGE OF CLASS 3 OXIDIZER LIQUIDS AND SOLIDS**

STORAGE CONFIGURATION	LIMITS		
	Control area storage	Group H occupancy storage	Detached storage
Piles			
Maximum width	12 feet	16 feet	20 feet
Maximum height	Note a	Note a	Note a
Maximum distance to aisle	8 feet	10 feet	10 feet
Minimum distance to next pile	Note b	Note b	Note b
Minimum distance to walls	4 feet	4 feet ^c	4 feet ^c
Maximum quantity per pile	NA	30 tons	100 tons
Maximum quantity per building	MAQ	1200 tons	No Limit

For SI: 1 foot = 304.8 mm, 1 pound = 0.454 kg, 1 ton = 0.907185 metric ton.

- a. Maximum storage height in nonsprinklered buildings is limited to 6 feet. In sprinklered buildings see NFPA 400 for storage heights based on ceiling sprinkler protection.
- b. The minimum aisle width shall be equal to the pile height, but not less than 4 feet and not greater than 8 feet.
- c. For protection level and detached storage under 2,300 pounds, there shall not be a minimum separation distance between the pile and any wall.

Reason:

This code change as a whole should be a formatting/editorial changes as follows:

6303.1 addresses requirements for oxidizer when below the MAQ. Therefore everything addressing Oxidizers below the MAQs has been renumbered as a subsection to 6303.1.

Section 6303.1.1 addresses special limitations for indoor storage and use by occupancy. Section 6303.1.1.2 was not related to a specific occupancy. Therefore it has been moved to 6303.1.5 with no change in content.

Section 6303 are the general requirements where MAQs are not exceeded. However there are control area columns in Table 6304.1.5(1) and (2) which address exceeding the MAQs instead of Section 6303. Therefore we have moved those columns and added them to existing table 6303.2 (which has been renumbered to 6303.1.4).

Additionally in Table 6303.1.4, for Class 2 and 3 oxidizers the maximum amount per building currently indicates "MAQ" which we believe is sending the user to Chapter 50 for MAQs and control areas. But as it is written it can be misinterpreted that the total amount of Class 2 and 3 Oxidizers PER BUILDING is limited to the basic MAQs (i.e. one control area) not combined MAQs in the control areas. Therefore "MAQ" has been revised to a Note d sending the user to Chapter 50.

Cost Impact

The code change proposal will not increase or decrease the cost of construction .

We believe this to be editorial for clarification.

Internal ID: 1626

F321-18

IFC: D103.2

Proponent: Bob Morgan, Fort Worth Fire Department, representing Fort Worth Fire Department

2018 International Fire Code

Revise as follows:

D103.2 Grade. Fire apparatus access roads shall not exceed 10 percent in grade. Where the fire code official determines that the fire apparatus access road will be utilized for ladder operations, the subject grade shall not exceed 6% in any direction.

Exception: Grades steeper than 10 percent as *approved* by the *fire code official*.

Reason:

Most apparatus manufacturers limit the ability to operate a ladder at a maximum 6% grade or require diminished ability to utilize the ladder at grades exceeding 6% whether in the direction of fire lane or cross slope.

Cost Impact

The code change proposal will increase the cost of construction .

The requirement for a lesser grade may increase the cost of construction of some projects having greater topographical constraints.

Internal ID: 922

F322-18

IFC: D103.5

Proponent: Joseph Hetzel, Thomas Associates, Inc., representing Door & Access Systems Manufacturers Association (jhetzel@thomasamc.com)

2018 International Fire Code

Revise as follows:

D103.5 Fire apparatus access road gates. Gates securing the fire apparatus access roads shall comply with all of the following criteria:

1. Where a single gate is provided, the gate width shall be not less than 20 feet (6096 mm). Where a fire apparatus road consists of a divided roadway, the gate width shall be not less than 12 feet (3658 mm).
2. Gates shall be of the ~~swinging or sliding~~ horizontal swing, horizontal slide, vertical lift or vertical pivot type.
3. Construction of gates shall be of materials that allow manual operation by one person.
4. Gate components shall be maintained in an operative condition at all times and replaced or repaired when defective.
5. Electric gates shall be equipped with a means of opening the gate by fire department personnel for emergency access. Emergency opening devices shall be *approved* by the *fire code official*.
6. Methods of locking shall be submitted for approval by the *fire code official*.
7. Electric gate operators, where provided, shall be *listed* in accordance with UL 325.
8. Gates intended for automatic operation shall be designed, constructed and installed to comply with the requirements of ASTM F2200.

Reason:

The proposal was previously designated as F401-16. Reasoning submitted at that time was as follows:

- Vertical lift gates and vertical pivot gates should be included in the criteria provision involving acceptable gate types because such gates can comply with the criteria in D103.5 including being covered in and being able to comply with UL 325 and ASTM F2200.
- Vertical lift gates can be designed to meet required minimum height clearances above roadways.
- The swinging and sliding gate type terminology has been revised to reflect terminology used in ASTM F2200.

During the Committee Action Hearing in 2016, the proposal was disapproved based on the view that vertical lift gates and vertical pivot gates cannot meet the criteria of "manual operation by one person" (D103.5, #3) and "a means of opening the gate...for emergency access" (D103.5, #5.)

DASMA then submitted a public comment requesting Approved as Submitted, with the following reasoning:

- All vehicular gates, including swinging and sliding gates, require site training and instruction for both manual operation and electric based emergency operation, and thus compliance with the stated criteria.
- A typical gate specification (under CSI Division 32 31 00) requires that the gate installer provide training in operation and safety of the gate.
- Training is needed because not only are there different methods for each gate type, but gate operator manufacturers, gate construction companies and automated gate system manufacturers may have different methods for the same gate type.
- Therefore, the two additional gate types should be equally acceptable with respect to the currently referenced gate types, allowing for site space conditions to dictate which gate type works best.

During the Final Action Hearings in 2016 the proposal was Approved as Submitted, but then failed by one vote to get the required 2/3 approval during the subsequent On-Line Governmental Voting period.

The proposal should be approved since it improves and clarifies the code, supported by the reasoning.

Cost Impact

The code change proposal will not increase or decrease the cost of construction .

The proposal is intended to clarify gate types and has no bearing on construction cost.

F323-18

IFC: D105.1

Proponent: Thomas Parsons, representing myself

2018 International Fire Code

Revise as follows:

D105.1 Where required. Where the vertical distance between the grade plane and the highest roof surface exceeds 30 feet (9144 mm), *approved* aerial fire apparatus access roads shall be provided.

For purposes of this section, the highest roof surface shall be determined by the greatest height measurement from average grade to:

1. the The eave of a pitched roof, the intersection of the roof to the exterior wall, or the top of parapet walls, whichever is greater, sloped roof which has a slope less than 60 degrees with the horizontal plane, and a roof surface less than 20 feet from the eave to the highest point on the roof;
2. The point that is 1/2 the vertical height of a sloped roof which has a slope less than 60 degrees with the horizontal plane and a roof surface greater than 20 feet from the eave to the highest point of the roof;
3. The top of a parapet wall;
4. The highest point of a flat roof;
5. The highest point of a sloped roof that is a slope 60 degrees or greater with the horizontal plane.

Reason:

1) The reason for the change is that fire department access to a sloped roof using a ground ladder is contingent upon using a roof ladder that can be secured to the slope of the roof. ISO fire suppression rating schedule requires fire department's to carry a roof ladder. Typically a pumper truck can carry a 16-foot roof ladder and a ladder truck can carry up to a 20-foot roof ladder. A sloped roof with a surface length greater than 20 feet from the eave to the highest part of the roof cannot be accessed from a ground ladder using a 20-foot roof ladder.

2) Roofs with a slope of 60 degrees or greater from the horizontal plane are defined under the building code as an exterior wall. A mansard roof is a sloped roof with a slope of 60 degrees or greater from the horizontal plane.

3) Dormers and openings in gable roofs that connect to habitable spaces are critical access and egress points for firefighters. Whether affecting a rescue, fire control, or ventilation, exterior access using a ladder up to a dormer window or gable window is necessary to for life safety and property conservation purposes.

Cost Impact

The code change proposal will increase the cost of construction .

Buildings with windows in dormers or gable roofs above 30 feet, will require aerial apparatus access. Buildings with a mansard roof with the highest roof surface above 30 feet will require aerial apparatus access. Buildings with sloped roofs that are longer than 20 feet from the eave to the peak, will require aerial access.

There may be additional costs to widen streets and roads, as well as remove obstructions for aerial apparatus access for the buildings that don't meet these exceptions.

Internal ID: 420

F324-18

IFC: D105.1

Proponent: Thomas Parsons, representing myself

2018 International Fire Code

Revise as follows:

D105.1 Where required. Where the vertical distance between the grade plane and the highest roof surface exceeds 30 feet (9144 mm), *approved* aerial fire apparatus access roads shall be provided. For purposes of this section, the highest roof surface shall be determined by measurement to the eave of a pitched roof, the intersection of the roof to the exterior wall, or the top of parapet walls, whichever is greater.

Exception: Buildings of Type IA, Type IB, or Type IIA Construction, equipped throughout with an automatic sprinkler system in accordance to Section 903.3.1.1; and having firefighter access through an enclosed stairway with a Class I Standpipe from the lowest level of fire department vehicle access to all roof surfaces.

Reason:

Fire Department Aerial Apparatus Access is rarely needed for Buildings of Type IA, Type IB, or Type IIA Construction, equipped throughout with an automatic sprinkler system in accordance to NFPA 13; and having firefighter access through an enclosed stair or stair(s) with a Type I Standpipe System from the lowest level of fire department vehicle access to all roof surfaces. Firefighting operations including ventilation can be achieved through the interior of these buildings using enclosed stairs as means of egress from the hazard area. The requirement for a Class I standpipe is for fire suppression and firefighter protection when operating hoselines at the roof or at a lower floor level. High rise buildings as required by 403.4.7 shall have means for smoke removal. These means do not require aerial apparatus access.

Cost Impact

The code change proposal will decrease the cost of construction .

The cost of widening existing streets and roads, and the cost of removing overhead obstructions along existing streets would be unnecessary if aerial apparatus access is not required for these types of buildings where aerial apparatus access would be rarely necessary.

Internal ID: 918

F325-18

IFC: D107.1

Proponent: Richard Boisvert, Brighton Area Fire Authority, representing Michigan Fire Inspector's Society (rboisvert@brightonareafire.com)

2018 International Fire Code

Revise as follows:

D107.1 One- or two-family dwelling residential developments. Developments of one- or two-family *dwelling units* where the number of *dwelling units* exceeds 30 shall be provided with two separate and *approved* fire apparatus access roads.

Exceptions:

1. Where there are more than 30 *dwelling units* ~~on~~accessed from a single public or private fire apparatus access road and all *dwelling units* are equipped throughout with an *approved automatic sprinkler system* in accordance with Section 903.3.1.1, 903.3.1.2 or 903.3.1.3, access from two directions shall not be required.
2. The number of *dwelling units* ~~on~~accessed from a single fire apparatus access road shall not be increased unless fire apparatus access roads will connect with future development, as determined by the *fire code official*.

Reason:

As written, the language implies that the 30 dwelling units must be on a single access road to qualify for the exceptions, however, the main code section for D107.1 refers to the "Development". This change in language will allow a development with a single access road (public or private), to qualify for the exceptions while having more than a single road in the development.

Cost Impact

The code change proposal will not increase or decrease the cost of construction .

This change is a typographical correction to clean up potential misinterpretation of the section.

Internal ID: 1134

F326-18

IFC: H104, H104.1 (New), H104.2 (New)

Proponent: Lynne Kilpatrick, Sunnyvale Department of Public Safety, representing Sunnyvale Department of Public Safety (lkilpatrick@sunnyvale.ca.gov); Rodney Lockett, U.S. Department of Homeland Security (ISCD), representing U.S. Department of Homeland Security, Infrastructure Security Compliance Division

2018 International Fire Code

Add new text as follows:

SECTION H104 SECURITY

H104.1 General. Hazardous materials storage, dispensing, use and handling areas shall be secured against unauthorized entry and safeguarded in a manner approved by the fire code official.

H104.2 Chemical Facility Anti-Terrorism Standards (CFATS). Chemical facilities deemed to be high risk by the U.S. Department of Homeland Security shall be required to develop and implement security plans in accordance with the Chemical Facility Anti-Terrorism Standards (CFATS) set forth in 6 CFR Part 27.

Revise as follows:

SECTION H104H105 REFERENCED STANDARD ~~IBC-18~~

~~ICC~~
~~IBC-18~~International Building Code
~~DHS CFATS~~
~~U.S. DEPARTMENT OF HOMELAND SECURITY, INFRASTRUCTURE SECURITY COMPLIANCE DIVISION~~
~~6 CFR Part 27 - 2007 Chemical Facility Anti-Terrorism Standards - H104.2~~

Reason:

The U.S. Department of Homeland Security (DHS) has developed regulations to strengthen security at the nation's highest-risk chemical facilities by developing Chemical Facility Anti-Terrorism Standards (CFATS) published in the Code of Federal regulations. This proposal is not intended to require the fire code official to enforce the CFATS regulations but rather is intended to ensure that fire code officials and chemical facility operators are aware of the existence of these regulations. Chemical facility operators are able to determine whether the facility possesses Chemicals of Interest (COI) covered by the Standard at or above the applicable Screening Threshold Quantity (STQ) under CFATS and thus required to submit a Top-Screen document to DHS, by referring to Appendix A of 6 CFR Part 27 or online at https://www.dhs.gov/xlibrary/assets/chemsec_appendixafinalule.pdf.

The Chemical Facility Anti-Terrorism Standards (CFATS) program identifies and regulates high-risk chemical facilities to ensure they have security measures in place to reduce the risks associated with these chemicals. Initially authorized by Congress in 2007, the program uses a dynamic multi-tiered risk assessment process and requires facilities identified as high-risk to meet and maintain performance-based security standards appropriate to the facilities and the risks they pose.

Cost Impact

The code change proposal will not increase or decrease the cost of construction .

High-risk chemical facilities needing to comply with the federal Chemical Facility Anti-Terrorism Standards may be required to enhance on-site security infrastructure. The reference standard is used to determine whether a chemical facility is required to comply with the US Department of Homeland Security Chemical Facility Anti-Terrorism Standards.

Analysis: A review of the standard proposed for inclusion in the code,U.S. DEPARTMENT OF HOMELAND SECURITY, INFRASTRUCTURE SECURITY COMPLIANCE DIVISION 6 CFR Part 27 - 2007 Chemical Facility Anti-Terrorism Standards , with regard to the ICC criteria for referenced standards (Section 3.6 of CP#28) will be posted on the ICC website on or before April 2, 2018.

Internal ID: 1765

F327-18

IFC: N107.5, N107.5.1, N107.5.2

Proponent: Michael O'Brian, Chair, representing FCAC (FCAC@iccsafe.org); Bruce Swiecicki, representing National Propane Gas Association (bswiewicki@npga.org)

2018 International Fire Code

Revise as follows:

N107.5 Liquid propane-LP-gas containers. ~~Liquid propane-Liquefied petroleum (LP) gas containers shall comply with Sections N107.5.1 through N107.5.5 and Chapter 61.~~

N107.5.1 LP-gas containers exceeding 12 pounds (5 kg) of water capacity. The use of LP-gas containers exceeding 12 pounds (5 kg) of water capacity shall be prohibited.

N107.5.2 Where more than one LP-gas container is present in the same area. ~~Where more than one LP-gas container is present in the same area, the aggregate weight of all containers in the area shall not exceed 12 pounds (5 kg) of water capacity.~~ cylinders shall be separated from each other by a minimum of 20 feet.

Reason:

O'Brian:

Several fatal events were analyzed related to outdoor public gatherings and structural failures in the development of these new code requirements to improve the authority of code officials to ensure public safety and create a level playing field for the owners of tents, outdoor structures and the promoters of outdoor gatherings by providing a reasonable set of code requirements for these structures and events.

This proposal is a minor change to correct the requirements for LP-gas use. The current requirements for utilizing LP-gas in trade shows are too restrictive because they only allow one 5-pound propane cylinder for an entire trade show floor. That is obviously unrealistic. One would expect to see hearth products such as fireplaces, as well as radiant heaters and other appliances on the show floor.

This proposal will correlate Appendix N with 6103.2.1.5 and will also bring the IFC into harmony with paragraph 6.22.9.1 of NFPA 59-2017.

The containers that will be used are DOT approved cylinders that conform to the federal requirements in Title 49 of the Code of Federal Regulations. Cylinders over 4 pounds through 40 pounds propane capacity will also have cylinder valves installed that provide safety attributes such as not flowing gas unless the connection to the appliance has been made properly; a thermal link that will shut off the flow of gas when the connection is subjected to elevated temperatures (225F), and an excess flow protection device that is contained in the appliance-side connection so that if the connecting hose is severed, the check valve will operate and stop the flow of gas.

This proposal is submitted by the ICC Fire Code Action Committee (FCAC). The FCAC was established by the ICC Board of Directors to pursue opportunities to improve and enhance assigned International Codes with regard to fire safety and hazardous materials in new and existing buildings and facilities and the protection of life and property in wildland urban interface areas. In 2017 the Fire-CAC has held 3 open meetings. In addition, there were numerous conference calls, Regional Work Group and Task Group meetings for the current code development cycle, which included members of the committees as well as any interested parties, to discuss and debate the proposed changes. Related documentation and reports are posted on the FCAC website at: <https://www.iccsafe.org/codes-tech-support/cs/fire-code-action-committee-fcac/>

Swiecicki:

The proposed change to N107.5 will reference the correct spelling for the term "LP-Gas." Also, the reference to Chapter 61 is appropriate since that chapter addresses LP-gas.

The current requirements for utilizing LP-gas in trade shows are too restrictive because they only allow one 5-pound propane cylinder for an entire trade show floor. That is obviously unrealistic. One would expect to see hearth products such as fireplaces, as well as radiant heaters and other appliances on the show floor.

This proposal will correlate Appendix N with 6103.2.1.5 and will also bring the IFC into harmony with paragraph 6.22.9.1 of NFPA 58-2017.

The containers that will be used are DOT approved cylinders that conform to the federal requirements in Title 49 of the Code of Federal Regulations. Cylinders over 4 pounds through 40 pounds propane capacity will also have cylinder valves installed that provide safety attributes such as not flowing gas unless the connection to the appliance has been

made properly; a thermal link that will shut off the flow of gas when the connection is subjected to elevated temperatures (225F), and an excess flow protection device that is contained in the appliance-side connection so that if the connecting hose is severed, the check valve will operate and stop the flow of gas.

Cost Impact

The code change proposal will not increase or decrease the cost of construction .

O'Brian:

This proposal amends an Appendix that may be adopted by a jurisdiction. The proposal adjusts propane use requirements for indoor trade shows which has no correlation to building construction or cost of construction.

Swiecicki:

Note that Bruce Swiecicki noted that this would reduce the cost of construction. This proposal will decrease the cost of construction by permitting small portable cylinders to be used for trade show exhibitions instead of having to pipe or run hose from inside an exhibition hall to the outdoors where a large container may be serving the exhibition.

Internal ID: 257

F328-18

IFC: Appendix O (New), O101 (New), O101.1 (New), O101.2 (New), O101.3 (New), O101.4 (New), O101.5 (New), O102 (New)

Proponent: Michael O'Brian, Chair, representing FCAC (fcac@iccsafe.org)

2018 International Fire Code

Add new text as follows:

APPENDIX O **FIRE INSPECTIONS AND FIRE PLAN EXAMINER QUALIFICATIONS**

O101 QUALIFICATIONS

O101.1 Fire Marshal/Fire code official. The fire marshal/fire code official shall have experience as a firefighter or fire officer, architect, fire protection engineer, inspector, fire protection contractor or some combination of these fields. In addition, the fire marshal/fire code official shall have experience and/or formal training in supervisory skills. The fire code official shall be certified as a fire code official, fire marshal, or fire protection engineer through a recognized licensure or certification program. With the exception of architects and fire protection engineers, certification or licensure for fire marshal shall demonstrate the qualifications outlined in NFPA 1037. The fire marshal/fire code official shall be appointed or hired by the fire chief or executive management of the governing authority.

O101.2 Chief fire inspector. The fire marshal/fire code official is authorized to designate chief fire inspectors to serve as supervisors or fire service officers to administer the provisions of the International Fire Code and to supervise plans examiners and inspectors. Each supervisor or fire service officer in the role of chief fire inspector shall have experience as a firefighter or fire officer, architect, fire protection engineer, inspector, fire protection contractor, or some combination of these fields. In addition, when chief fire inspectors are appointed, they shall have experience or formal training in supervisory skills. The chief fire inspector shall be certified or licensed through a recognized licensure or certification program as a fire inspector, fire safety inspector, fire code plans examiner, fire protection engineer, or in an equivalent field of expertise. With the exception of architects and fire protection engineers, certification or licensure programs for chief fire inspector shall demonstrate qualifications in accordance with NFPA 1037 or NFPA 1031.

O101.3 Fire code plans examiner. The fire marshal/fire code official shall appoint or hire such number of officers, plans examiners, assistants and other employees as shall be authorized by the jurisdiction. To be appointed or hired as a fire code plans examiner experience as a firefighter, fire officer, fire inspector, building inspector/plans examiner, fire protection contractor, fire protection engineer or engineer in training , or architect is required. An Associate Degree in Fire Protection or Building Construction Technology shall be deemed an acceptable alternative for the necessary experience. The fire code plans examiner shall be certified or licensed through a recognized licensure or certification program as a fire code plans examiner, combination fire inspector/plans examiner, fire protection engineer, or in an equivalent field of expertise. With the exception of architects and fire protection engineers, certification or licensure programs for fire inspector or plans examiner shall demonstrate qualifications in accordance with NFPA 1031. Entry level employees or trainees shall be permitted to be hired and assigned to work under the direction and authority of the fire marshal/fire code official while obtaining the required experience and certification(s).

O101.4 Fire inspector. The fire marshal/fire code official is authorized to appoint or hire such number of officers, inspectors, assistants and other employees as shall be authorized by the jurisdiction. A person shall not be appointed or hired as fire code inspector who has not had experience as a firefighter, fire officer, fire protection contractor, fire protection engineer or engineer in training, or architect. Completion of 15 semester units or 22 quarter units from a recognized college in Fire Protection or Building Construction Technology shall be an acceptable alternative to the one year of experience. The fire code inspector shall be certified or licensed through a recognized licensure or certification program as a fire inspector, combination fire inspector/plans examiner, fire safety inspector, fire protection engineer, or in an equivalent field of expertise. With the exception of architects and fire protection engineers, certification or licensure programs for fire inspector or plans examiner shall demonstrate qualifications in accordance with NFPA 1031.. Entry level employees or trainees shall be permitted to be hired and assigned to work under the direction and authority of the fire marshal/fire code official while obtaining the required experience and certification(s).

O101.5 Termination of employment. Employees in the position of fire marshal, fire code official, chief fire inspector, fire inspector, or fire code plans examiner shall not be removed from office except for cause after full opportunity has been given to be heard on specific charges before such applicable governing authority.

0102 REFERENCED STANDARDS

NFPA 1031-2014 Standard for Professional Qualifications for Fire Inspector and Plan Examiner

NFPA 1037-2016 Standard on Fire Marshal Professional Qualifications

Reason:

This proposed change is result of an evaluation of previous work by the CTC that was based on the “NIST Charleston Sofa Store Fire Recommendations”. This work and the follow-up work of the FCAC addresses the NIST and other investigative reports on the fire that occurred on the evening of June 18, 2007 in the Sofa Super Store in Charleston, South Carolina to identify issues that can be addressed by the International Codes.

In connection with their investigation, NIST analyzed the fire ground, consulted with other experts, and performed computer simulations of fire growth alternatives. Based on these analyses, NIST concluded that the following sequence of events is likely to have occurred. A fire began in packing material and discarded furniture outside an enclosed loading dock area. The fire spread to the loading dock, then into both the retail showroom and warehouse spaces. During the early stages of the fire in the two latter locations, the fire spread was slowed by the limited supply of fresh air. This under-ventilation led to generation of a large mass of pyrolyzed and only partially oxidized effluent. The smoke and combustible gases flowed into the interstitial space below the roof and above the suspended ceiling of the main retail showroom. As this space filled with unburned fuel, the hot smoke also seeped through the suspended ceiling into the main showroom and formed a hot smoke layer below the suspended ceiling. Up to this time, the extent of fire spread into the interstitial space was not visible to fire fighters in the store. If the fire spread had been visible to the fire fighters in the store, it would have provided a direct indication of a fire hazard in the showroom. Meanwhile, the fire at the back of the main showroom and the gas mixture below the suspended ceiling were both still fuel rich. When the front windows were broken out or vented, the inflow of additional air allowed the heat release rate of the fire to intensify rapidly and added air to the layer of unburned fuel below the suspended ceiling enabling the ignition of the unburned fuel/air mixture. The fire swept from the rear to the front of the main showroom extremely quickly, and then into the west and east showrooms. Nine fire fighters were killed in the Sofa Super Store fire. NIST developed eleven recommendations to help mitigate such future losses.

Recommendation 3 of the NIST report reads as follows:

“Qualified Fire Inspectors and Building Plan Examiners: NIST recommends that all state and local jurisdictions ensure that fire inspectors and building plan examiners are professionally qualified to a national standard such as NFPA 1031 Standard for Professional Qualifications for Fire Inspector and Plan Examiner. Professional qualification may be demonstrated through a nationally accepted certification examination, such as the Fire Plan Examiner; Fire Inspector I and II, and Certified Fire Marshal.”

Following a review of recommendation 3 of the NIST report a new Appendix K is proposed. This proposal is similar in scope and intent to Section A101.3 of Appendix A of the International Building Code where suggested qualifications for building official, chief inspector, inspector and plan examiner are established.

The purpose of this proposal is to provide optional criteria for qualifications of employees who enforce the Fire Code through inspections and plan examinations. A jurisdiction that wants to make this appendix a mandatory part of the code would need to specifically list this appendix in its adoption ordinance. In recognition of the fact that some jurisdictions are mandated by applicable state law to employ only persons licensed by the state to perform certain duties, the proposal was drafted as an Appendix.

This proposal would not require fire inspectors or fire plan examiners to have had previous experience in Fire Code enforcement, but would merely require that they possess experience in a related job category. As with the efforts by the CTC, it is not the intent of the FCAC to prohibit a plan review and inspection staff from hiring and training entry level employees. The training of such entry level should simply be supervised by trained and certified personnel.

This proposal is submitted by the ICC Fire Code Action Committee (FCAC). The FCAC was established by the ICC Board of Directors to pursue opportunities to improve and enhance assigned International Codes with regard to fire safety and hazardous materials in new and existing buildings and facilities and the protection of life and property in wildland urban interface areas. In 2017 the Fire-CAC has held 3 open meetings. In addition, there were numerous conference calls, Regional Work Group and Task Group meetings for the current code development cycle, which included members of the committees as well as any interested parties, to discuss and debate the proposed changes. Related documentation and reports are posted on the FCAC website at: <https://www.iccsafe.org/codes-tech-support/cs/fire-code-action-committee-fcac/>

Cost Impact

The code change proposal will not increase or decrease the cost of construction .

This proposal should not have any direct impact on the cost of construction. This proposal deals with the jurisdiction that serves as the authority having jurisdiction and the qualifications of personnel involved with applying and enforcing the fire code. If there are any cost impacts to construction it would possibly be the permitting costs necessary to

adequately staff the fire code enforcement authority with qualified personnel.

Internal ID: 1922

2018 GROUP A – PROPOSED CHANGES TO THE INTERNATIONAL FUEL GAS CODE

FUEL GAS CODE COMMITTEE

Michael D. Redifer, MCP, Chair
Building Official
City of Newport News
Newport News, VA

Paul W. Cabot, CGE, Vice Chair
Administrator National Fuel Gas Code
American Gas Association
Washington, DC

Mike Deegan
Rep: American Gas Association
Safety & Regulatory Compliance
Clearwater Gas System
Clearwater, FL

Ralph E. Euchner
Rep: American Gas Association
Operations Manager
PSNC Energy/AGA
Gastonia, NC

William T. Hamilton, CGI
Rep: American Gas Association
Manager, Technical Training
UGI Utilities, Inc.
Reading, PA

Randy Lee
Code Inspector
City of Decatur
Tuscumbia, AL

Andrea Lanier Papageorge, JD, MBA
Rep: American Gas Association
Manager, Building and Gas Codes and
Standards
Southern Company Gas
Atlanta, GA

New York Department of Buildings
New York, NY

Mark Riley
Mechanical Inspector
City of Royal Oak Building Department
Royal Oak, MI

Jason Stanek, PE
Rep: American Gas Association
Manager, Commercial & Contractor Services
Metropolitan Utilities District
Omaha, NE

Timothy H. Swanson, CBCO, CFCO
Chief Building Official
City of Greeley
Greeley, CO

Staff Secretariat:

Gregg Gress
Senior Technical Staff
International Code Council
Central Regional Office
Country Club Hills, IL

AGA Liaison

Jim Ranfone, Managing Director
American Gas Association
Washington, DC

Kathleen Patterson, RA
Codes Development Architect

TENTATIVE ORDER OF DISCUSSION 2018 PROPOSED CHANGES TO THE INTERNATIONAL FUEL GAS CODE

The following is the tentative order in which the proposed changes to the code will be discussed at the public hearings. Proposed changes which impact the same subject have been grouped to permit consideration in consecutive changes.

Proposed change numbers that are indented are those which are being heard out of numerical order. Indentation does not necessarily indicate that one change is related to another. Proposed changes may be grouped for purposes of discussion at the hearing at the discretion of the chair. Note that some FG code change proposals may not be included on this list, as they are being heard by another committee.

FG1-18
FG2-18
FG3-18
FG4-18
FG5-18
FG6-18
FG7-18
FG8-18
 P1-18 Part IV
FG9-18
 F122-18 Part II
FG10-18
FG11-18
FG12-18
FG13-18
FG14-18
FG15-18
FG16-18
FG17-18
FG18-18
FG19-18
FG20-18
FG21-18
FG22-18
FG23-18
FG24-18
FG25-18
FG26-18
FG27-18
FG28-18
FG29-18

FG1-18

IFGC: 202

Proponent: James Ranfone, representing American Gas Association (jranfone@aga.org)

THIS CODE CHANGE PROPOSAL HAS BEEN PLACED ON THE IMC COMMITTEE AGENDA. PLEASE SEE THE IMC HEARING ORDER.

2018 International Fuel Gas Code

Revise as follows:

[M] PIPING. Where used in this code, "piping" refers to either pipe or tubing, or both.

Pipe. A rigid conduit ~~of iron, steel, copper, copper alloy or plastic~~ used to convey fuel gas or other fluid.

Tubing. Semirigid conduit ~~of copper, copper alloy aluminum, plastic or steel~~ used to convey fuel gas or other fluid.

Reason:

Definitions should not contain technical requirements. The code in other sections provide the list of acceptable materials. The deletion would coordinate with the definition as revised in the 2018 National Fuel Gas Code.

Cost Impact

The code change proposal will not increase or decrease the cost of construction .

The definition changes do not impact the code's installation requirements.

Internal ID: 1370

FG2-18

IFGC: 202 (New)

Proponent: James Ranfone, representing American Gas Association (jranfone@aga.org)

2018 International Fuel Gas Code

Add new definition as follows:

SERVICE METER ASSEMBLY. The meter, valve, regulator, piping, fittings and equipment installed by the service gas supplier before the point of delivery.

Reason:

The “Point of Delivery” definition uses the term “service meter assembly” but that term is not defined. The proposed would help clarify the code. AGA will also be proposing the same definition for the 2021 National Fuel Gas Code.

Cost Impact

The code change proposal will not increase or decrease the cost of construction .

The definition does not add code installation requirements.

Internal ID: 1668

FG3-18

IFGC: 202 (New)

Proponent: James Ranfone, representing American Gas Association (jranfone@aga.org)

2018 International Fuel Gas Code

Add new definition as follows:

SYSTEM SHUTOFF. A valve installed after the point of delivery to shut off the entire piping system.

Reason:

AGA is proposing a definition to cover a valve that may be installed for customer use to shut off the entire customer piping system. That valve would be installed downstream of the point of delivery (see proposed revision to POD definition) and would be owned by the customer. A similar definition and coverage for system shutoff valve is being proposed for the 2021 National Fuel Gas Code. Under current federal law, only qualified personnel are permitted to operate a gas utility's system components covered under the law. The gas service shutoff valve is one such covered component. Some gas utilities have chosen to provide a shutoff valve after the point of delivery as part of the service meter assembly for customer use to shut down their gas piping without the need to operate the gas utility's covered service shutoff valve.

Cost Impact

The code change proposal will not increase or decrease the cost of construction .

The new definition does not change the code's installation requirements.

Internal ID: 1382

FG4-18

IFGC: 202

Proponent: James Ranfone, representing American Gas Association (jranfone@aga.org)

2018 International Fuel Gas Code

Revise as follows:

VALVE. A device used in piping to control the gas supply to any section of a system of piping or to an appliance.

Service Shutoff. A valve, installed by the serving gas supplier between the source of supply and the point of delivery, to shut off the entire piping system.

Reason:

The revision clarify that the service shutoff valve is always installed between the gas supply and point of delivery. The point of delivery is a defined term.

Cost Impact

The code change proposal will not increase or decrease the cost of construction .

The definition change does not change the code's installation requirements.

Internal ID: 1379

FG5-18

IFGC: 202 (New)

Proponent: James Ranfone, representing American Gas Association (jranfone@aga.org)

2018 International Fuel Gas Code

Add new definition as follows:

SERVICE METER ASSEMBLY. The meter(s), valve(s), piping, fittings, and equipment installed by the serving gas supplier to connect the gas supply to the customer piping system.

Reason:

The “Point of Delivery” definition uses the term “service meter assembly” but that term is not defined. The proposed would help clarify the code. AGA will also be proposing the same definition for the 2021 National Fuel Gas Code.

Cost Impact

The code change proposal will not increase or decrease the cost of construction .

The new definition does not changed the code's installation requirements.

Internal ID: 1377

FG6-18

IFGC: 202

Proponent: James Ranfone, representing American Gas Association (jranfone@aga.org)

2018 International Fuel Gas Code

Revise as follows:

REGULATOR, MONITORING. A pressure regulator set in series with another pressure regulator for the purpose of automatically taking control of the pressure downstream of the monitored regulator when that pressure exceeds a set minimum, preventing an overpressure in the downstream piping system.

Reason:

Definitions should not contain technical requirements. Section 416 provide the pressure limits. The deletion would coordinate with the definition as revised the 2018 National Fuel Gas Code.

Cost Impact

The code change proposal will not increase or decrease the cost of construction .

The definition change does not impact the code's installation requirements.

Internal ID: 1375

FG7-18

IFGC: 202

Proponent: James Ranfone, representing American Gas Association (jranfone@aga.org)

2018 International Fuel Gas Code

Revise as follows:

POINT OF DELIVERY. For natural gas systems, the point of delivery is the outlet of the service meter assembly or the outlet of the service regulator or service shutoff valve where a meter is not provided. Where a system shutoff valve is provided ~~at~~after the outlet of the service meter assembly, such valve shall be considered to be downstream of the point of delivery. For undiluted liquefied petroleum gas systems, the point of delivery shall be considered to be the outlet of the service pressure regulator, exclusive of line gas regulators, in the system.

Reason:

AGA is also proposing coverage for a “system shutoff” valve and its inclusion in the POD definition clarifies that definition’s intent. The word “at” indicates that the valve will be very close to the POD. That may not be the case where a length of pipe may be installed prior to the installation of the valve. The word “after” would include all locations.

Cost Impact

The code change proposal will not increase or decrease the cost of construction .

The changes do not revise the code's installation requirements.

Internal ID: 1373

FG8-18

IFGC: 202 (New)

Proponent: Mark Fasel, representing Viega LLC (mark.fasel@viega.us)

2018 International Fuel Gas Code

Add new definition as follows:

PRESS-CONNECT JOINT A permanent mechanical joint incorporating an elastomeric seal or an elastomeric seal and corrosion-resistant grip or bite ring. The joint is made with a pressing tool and jaw or ring approved by the fitting manufacturer.

Reason:

The definition for Press-Connect Fittings is not included into the IFGC. The term Press-Connect Fittings are used in the International Fuel Gas Code sections 403.10.1 and 403.10.2. Adding the definition of Press-Connect Joint will align the definition already used in the IMC and IPC.

Cost Impact

The code change proposal will not increase or decrease the cost of construction .

This definition currently exists in other ICC model codes and is simply added for reference. This proposal is an additional option for a pipe joint method and will not require an added cost to construction.

Internal ID: 792

FG9-18

IFGC: 301.12

Proponent: Kelly Cobeen, Wiss Janney Elstner Associates, Inc., representing Federal Emergency Management Agency/Applied Technology Council Seismic Code Support Committee (KCobeen@wje.com); Michael Mahoney, Federal Emergency Management Agency, representing Federal Emergency Management Agency (mike.mahoney@fema.dhs.gov)

2018 International Fuel Gas Code

Revise as follows:

301.12 Seismic resistance. Where earthquake loads are applicable in accordance with the International Building Code, ~~the supports~~ fuel gas appliance and system supports, anchorage, and bracing shall be designed and installed for the seismic forces in accordance with Chapter 16 of that code.

Reason:

The added text clarifies the IBC location where specific seismic requirements are defined. This is simply intended to make the seismic design provisions more easily used, consistent with the intent as stated in 2015 NEHRP Recommended Provisions Section 1.1.2, to preserve life safety by maintaining the position of components through anchorage, bracing and strength.

Bibliography:

NEHRP Recommended Seismic Provisions for New Buildings and Other Structures, 2015 Edition (FEMA P-1050-1).

Cost Impact

The code change proposal will not increase or decrease the cost of construction .

The proposed wording clarifies the intent of the code and does not impose any new requirements that were not already in effect.

Internal ID: 1034

FG10-18

IFGC: 304.13(IFGS) (New)

Proponent: James Ranfone, representing American Gas Association (jranfone@aga.org)

2018 International Fuel Gas Code

Add new text as follows:

304.13(IFGS) Existing Appliances. Existing appliance installations shall be inspected to verify compliance with the provisions of Section 304 and Chapter 5 where a component of the building envelope is modified as described by one or more of 304.13 (1) through (6). Where the appliance installation does not comply with Section 304 and Chapter 5, the installation shall be altered as necessary to be in compliance with Section 304 and Chapter 5.

1. The building is modified under a weatherization program.
2. A building permit is issued for a building addition or exterior building modification.
3. Three or more window assemblies are replaced.
4. Three or more storm windows are installed over existing windows.
5. One or more exterior door and frame assemblies are replaced.
6. A building air barrier is installed or replaced.

Reason:

AGA is proposing an extract of section 9.1.24 from ANSI Z223.1, National Fuel Gas Code. The code requirement would address renovations to existing buildings that could impact the supply of combustion air and the performance of venting systems. AGA is aware of weatherization programs that fail to consider the importance of ensuring that existing gas appliance installations continue to meet the IFGC combustion air and venting requirements when efforts to reduce air infiltration are undertaken. This proposal is offered solely for coordinating the IFGC with ANSI Z223.1 (NFGC). This text is offered "as is" for the IFGC and it is not intended that such text be modified from a technical standpoint. The subject text was revised in the 2018 NFGC (ANSI Z223.1) and this proposal will cause the IFGC text to be consistent with such revised text in ANSI Z223.1 (NFGC).

Bibliography:

ANSI Z223.1 National Fuel Gas Code, American Gas Association, 2018

Cost Impact

The code change proposal will increase the cost of construction .

The new section will require inspections and possible modifications.

Internal ID: 1384

FG11-18

IFGC: 307.2

Proponent: Guy McMann, representing Colorado Association of Plumbing and Mechanical Officials (CAPMO)
(gcmcmann@jeffco.us)

2018 International Fuel Gas Code

Revise as follows:

307.2 Fuel-burning appliances. Liquid combustion byproducts of condensing appliances shall be collected and discharged to an approved plumbing fixture or disposal area in accordance with the manufacturer's instructions. Condensate piping shall be of approved corrosion-resistant material and shall be not smaller than the drain connection on the appliance. Such piping shall maintain a minimum slope in the direction of discharge of not less than one-eighth unit vertical in 12 units horizontal (1-percent slope).

Where condensate piping is concealed, and the primary and secondary drain system pipes serving the same appliance terminate together at a remote location, the terminations shall be identified as to which is the primary or secondary drain.

Reason:

Reason: Condensate drain systems from the same appliance need to be identified when terminating together at a remote location when the piping is concealed or partially concealed and could have possibly changed orientation. Occupants and service personnel won't be able to tell by looking at the piping which system is discharging and can't identify if they have a problem.

Cost Impact

The code change proposal will not increase or decrease the cost of construction .

Simple identification should not increase cost.

Internal ID: 122

FG12-18

IFGC: 401.5

Proponent: Bob Torbin, OmegaFlex, representing OmegaFlex (bob.torbin@omegaflex.net)

2018 International Fuel Gas Code

Revise as follows:

401.5 Identification. For other than steel pipe and CSST, exposed *pipng* shall be identified by a yellow label marked "Gas" in black letters. The marking shall be spaced at intervals not exceeding 5 feet (1524 mm). The marking shall not be required on ~~pipe~~ pipng located in the same room as the *appliance* served. CSST shall be identified as required by ANSI LC 1/CSA 6.26.

Reason:

Recent changes in the ANSI LC-1 Standard for CSST now permits the CSST jacket to be either yellow or black. The marking requirements of LC-1 permit the marking color to be selected by the manufacturer provided it is a high contrasting color compared to the jacket color (such as white on black). The marking requirement also requires the word "Fuel Gas" be printed every two feet along the tubing. The proposed modification recognizes that the marking requirements of ANSI LC-1 can meet the intent of the marking requirements of the Identification Section as an equivalent marking.

The replacement of the word "pipe" in the third sentence with the word "pipng" reflects the marking application is intended only for copper pipe/tubing and CSST, and thus reflects the proper use of the term as defined in Chapter 2.

Cost Impact

The code change proposal will decrease the cost of construction .

The use of factory-marked tubing results in cost savings because this avoids the labor and material costs of separately installing stick-on labels to field-installed piping.

Internal ID: 1092

FG13-18

IFGC: 404.2

Proponent: Shannon Corcoran, CSA Group, representing CSA Group (shannon.corcoran@csagroup.org)

2018 International Fuel Gas Code

Revise as follows:

404.2 CSST. CSST piping systems shall be installed in accordance with the terms of their approval, the conditions of listing in accordance with ANSI LC 1/CSA 6.26, the manufacturer's instructions and this code.

Reason:

The purpose of this proposal is to clarify the intent that CSST is installed in accordance with the manufacturer's listing to the applicable ANSI standard, ANSI LC 1 / CSA 6.26.

Cost Impact

The code change proposal will not increase or decrease the cost of construction .

The references will increase the need for products to comply, however compliance to the referenced standards is not expected to impact the cost of construction.

Internal ID: 1114

FG14-18

IFGC: 404.5

Proponent: Guy McMann, representing Colorado Association of Plumbing and Mechanical Officials (CAPMO)
(gcmcmann@jeffco.us)

2018 International Fuel Gas Code

Revise as follows:

404.5 Fittings in concealed locations. Fittings installed in concealed locations shall be limited to the following types:

1. ~~Threaded Right-hand- threaded elbows, tees, couplings, plugs and couplings-caps.~~
2. Brazed fittings.
3. Welded fittings.
4. Fittings listed to ANSI LC-1/CSA 6.26 or ANSI LC-~~4-4~~.

Reason:

Not all fittings are in the list. Unions are not permitted to be concealed and left-right couplings are still being used. These couplings are a form of union.

Cost Impact

The code change proposal will not increase or decrease the cost of construction .

This proposal is editorial in nature.

Internal ID: 186

FG15-18

IFGC: 404.6

Proponent: James Ranfone, representing American Gas Association (jranfone@aga.org)

2018 International Fuel Gas Code

Delete and substitute as follows:

~~**404.6 Underground penetrations prohibited.** Gas piping shall not penetrate building foundation walls at any point below grade. Gas piping shall enter and exit a building at a point above grade and the annular space between the pipe and the wall shall be sealed.~~

404.6 Underground penetrations prohibited.Piping through foundation wall. ~~Gas piping shall not penetrate building foundation walls at any point below grade. Gas piping shall enter and exit a building at a point above grade and the~~ Underground piping where installed below grade through the foundation or basement wall of a building shall be encased in a protective pipe sleeve. The annular space between the pipe-gas piping and the wall sleeve shall be sealed.

Reason:

A change adopted into the 2015 edition prohibits gas piping from penetrating a foundation or basement wall below grade. This change was adopted without evidence that such penetrations have resulted in a safety concern. Below grade penetrations have a long been permitted and have proven to be a safe installation method. The revised language would reinstate this allowance. At least one State, Georgia, has amended the IFGC to delete the prohibition and allow below grade penetration like the proposed text. GA text is as follows: "404.6 Piping through foundation wall. Underground piping where installed below grade through the foundation or basement wall of a building, shall be encased in a protective pipe sleeve. The annular space between the gas piping and the sleeve shall be sealed."

Cost Impact

The code change proposal will decrease the cost of construction .

The change will reduce the need to bring piping above ground in some installations. That will reduce the length of piping required as well as reduce the number of fittings used.

Internal ID: 1385

FG16-18

IFGC: 404.11.2

Proponent: Bob Torbin, OmegaFlex, representing OmegaFlex (bob.torbin@omegaflex.net)

2018 International Fuel Gas Code

Revise as follows:

404.11.2 Protection methods. Underground piping shall comply with one or more of the following:

1. The piping shall be made of corrosion-resistant material that is suitable for the environment in which it will be installed.
2. Pipe shall have a factory-applied, electrically-insulating coating. Fittings and joints between sections of coated pipe shall be coated in accordance with the coating manufacturer's instructions.
3. The piping shall have a cathodic protection system installed and the system shall be monitored and maintained in accordance with an *approved* program.
4. The piping shall be installed within an encasement system listed for underground use or within a non-metallic, watertight conduit.

Reason:

The ICC Evaluation Service issued a listing criteria for polyethylene sleeved CSST (LC 1023) dated May 2009. The use of listed encasement systems (such as polyethylene sleeved CSST) has been included in the National Fuel Gas Code (NFPA 54) Section 7.1.6 since the 2012 edition, and was included in the 2018 edition of the International Fuel Gas Code. This type of product has been used underground without failure or damage for approximately 15 years. Use of pre-assembled encasement systems streamlines the installation of gas piping underground or beneath buildings and concrete slabs, and can be installed underground without joints where required. This will improve safety (no potential leakage sites) when installing such systems. The use of buried conduit is already permitted by Section 404.14 piping underground beneath buildings, but needs to be added here for consistency.

Cost Impact

The code change proposal will decrease the cost of construction .

The use of buried conduit is already permitted by Section 404.14 piping underground beneath buildings. The use of a listed encasement system results in cost savings because the piping and encasement are installed simultaneously.

This avoids the labor cost of separately installing the conduit and piping. In addition, the sealing and venting methods (when required) are also integrated within the encasement system, thus eliminating the need to separately assemble and/or install sealing and venting components within standard conduit.

Internal ID: 1097

FG17-18

Proponent: James Ranfone, representing American Gas Association (jranfone@aga.org)

2018 International Fuel Gas Code

Delete without substitution:

~~**404.11.5 Prohibited use.** Uncoated threaded or socketwelded joints shall not be used in piping in contact with soil or where internal or external crevice corrosion is known to occur.~~

Reason:

Section 404.11.2 #2 requires that all piping have a factory-applied protective coating and that fittings and joints between sections of coated pipe shall be coated in accordance with the coating manufacturer's instructions. Therefore section 404.11.5 is not needed. We note that most of 404.11 is new for the 2018 edition and section 404.11.5 which was in previous editions should have been deleted when this new material was added.

Cost Impact

The code change proposal will not increase or decrease the cost of construction .

Section 404.11.2 #2 requires coated piping.

Internal ID: 855

FG18-18

IFGC: 404.18

Proponent: James Ranfone, representing American Gas Association (jranfone@aga.org)

2018 International Fuel Gas Code

Revise as follows:

404.18 Pipe ~~cleaning~~ debris removal. The interior of piping shall be clear of debris. The use of a flammable or combustible gas to clean or remove debris from a *piping* system shall be prohibited.

Reason:

The code prohibits the use of flammable or combustible gas to clean piping but does not require piping to be clear of debris. The proposed text would add in the requirement which would also harmonize it with the National Fuel Gas Code.

Cost Impact

The code change proposal will not increase or decrease the cost of construction .

Pipe is usually cleared of debris as it is being assembled . No change in the code's installation requirements.

Internal ID: 1663

FG19-18

IFGC: 404.18

Proponent: James Ranfone, representing American Gas Association (jranfone@aga.org)

2018 International Fuel Gas Code

Revise as follows:

404.18 Pipe cleaning. Prior to testing, the interior of the piping system shall be cleared of all debris. The use of a flammable or combustible gas to clean or remove debris from a piping system shall be prohibited.

Reason:

The code prohibits the use of flammable or combustible gas to clean piping but does not require piping to be cleaned. The proposed text would add in the requirement which would also harmonize it with the National Fuel Gas Code.

Cost Impact

The code change proposal will increase the cost of construction .

The revision clarifies that all piping is to be cleaned and therefore may increase the cost of construction.

Internal ID: 1356

FG20-18

IFGC: 409.8 (New)

Proponent: John Cecil II, representing self (jcecil@msn.com)

2018 International Fuel Gas Code

Add new text as follows:

409.8 Building shutoff. A shutoff valve that will shutoff the gas supply to the entire building shall be installed, indoors or outdoors, within 6 feet of the entrance of the gas supply piping into the building. The shutoff valve shall not require the use of a tool to operate it.

Reason:

Reason: The shutoff valve will allow the gas supply to the building to be shutoff in an emergency without having to utilize the utility owned shutoff valve located upstream of the meter and service regulator equipment..

Bibliography:

Submitted by John Allan Cecil, presently a combination inspector for Garrett County, MD. jcecil@msn.com 240-381-6231

Cost Impact

The code change proposal will increase the cost of construction .

The cost of this Code change would be minimum, basically the cost of a gas valve. The value would be, is that there would be one location, one valve, to turn off the whole house gas supply if there is an emergency.

Internal ID: 494

FG21-18

IFGC: 411.1, Chapter 8, 08

Proponent: Shannon Corcoran, representing CSA Group (shannon.corcoran@csagroup.org)

2018 International Fuel Gas Code

Revise as follows:

411.1 Connecting appliances. Except as required by Section 411.1.1, *appliances* shall be connected to the *pipng* system by one of the following:

1. Rigid metallic pipe and fittings.
2. Corrugated stainless steel tubing (CSST) where installed in accordance with the manufacturer's instructions.
3. Semirigid metallic tubing and metallic fittings. Lengths shall not exceed 6 feet (1829 mm) and shall be located entirely in the same room as the *appliance*. Semirigid metallic tubing shall not enter a motor-operated *appliance* through an unprotected knockout opening.
4. *Listed and labeled appliance* connectors in compliance with ANSI Z21.24/CGA 6.10 and installed in accordance with the manufacturer's instructions and located entirely in the same room as the appliance.
5. *Listed and labeled quick-disconnect devices in compliance with ANSI Z21.41/CGA 6.9* used in conjunction with *listed and labeled appliance* connectors.
6. *Listed and labeled convenience outlets in compliance with ANSI Z21.90/CGA 6.24* used in conjunction with *listed and labeled appliance* connectors.
7. *Listed and labeled outdoor appliance* connectors in compliance with ANSI Z21.75/CSA 6.27 and installed in accordance with the manufacturer's instructions.
8. *Listed outdoor gas hose connectors* in compliance with ANSI Z21.54 used to connect portable outdoor appliances. The gas hose connection shall be made only in the outdoor area where the appliance is used, and shall be to the *gas pipng* supply at an appliance shutoff valve, a listed quick-disconnect device or listed gas convenience outlet.
9. Gas hose connectors for use in laboratories and educational facilities in accordance with Section 411.4.

CHAPTER 8 REFERENCED STANDARDS

Add new standard(s) follows:

ANSI

American National Standards
Institute
25 West 43rd Street 4th Floor
New York NY 10036

ANSI Z21.41/CSA 6.9-2014:

Quick disconnect devices for use with gas fuel appliances

ANSI Z21.90/CSA 6.24-2015:

Gas convenience outlets and optional enclosures

Reason:

This proposal is intended to provide clarity in the Code by including reference to the applicable ANSI standard for quick-disconnect devices (ANSI Z21.41/CSA 6.9) and convenience outlets (ANSI Z21.90/CSA 6.24).

Cost Impact

The code change proposal will not increase or decrease the cost of construction .

The references will increase the need for products to comply, however compliance to the referenced standards is not expected to impact the cost of construction.

Analysis: A review of the standard proposed for inclusion in the code, with regard to the ICC criteria for referenced standards (Section 3.6 of CP#28) will be posted on the ICC website on or before April 2, 2018.

Internal ID: 1136

FG22-18

IFGC: SECTION 413 (IFGC), [F] 413.1, [F] 413.2, [F] 413.2.1, [F] 413.2.2, 413.2.3, 413.2.4 (New), [F] 413.3, [F] 413.3.1, 413.4, , [F] 413.4.3, 413.5 (New), 413.6, 413.7, 413.8, 413.10, 413.9, 413.10.1, 413.10.2, 413.10.2.1, 413.10.2.2, 413.10.2.3, [F] TABLE 413.10.2.3, 413.10.2.6, 413.10.2.4, 413.10.2.5, ordinal

Proponent: Ted Williams, American Gas Association, representing American Gas Association (twilliams@aga.org)

THIS CODE CHANGE PROPOSAL HAS BEEN PLACED ON THE IFC COMMITTEE AGENDA. PLEASE SEE THE IFC HEARING ORDER.

2018 International Fuel Gas Code

SECTION 413 (IFGC) COMPRESSED NATURAL GAS MOTOR VEHICLE FUEL-DISPENSING FACILITIES

[F] 413.1 General. Motor fuel-dispensing facilities for CNG fuel shall be in accordance with this section and the International Fire Code. The operation of CNG motor fuel-dispensing facilities shall be regulated by the International Fire Code.

[F] 413.2 General. Storage vessels and *equipment* used for the storage, compression or dispensing of CNG shall be *approved* or *listed* in accordance with Sections 413.2.1 through 413.2.3.

[F] 413.2.1 Approved equipment. Containers; compressors; pressure-relief devices, including pressure-relief valves; and pressure regulators and *pipng* used for CNG shall be *approved*.

[F] 413.2.2 Listed equipment. Hoses, hose connections, dispensers, gas detection systems and electrical *equipment* used for CNG shall be *listed*. Vehicle fueling connections shall be *listed* and *labeled*.

Revise as follows:

[F] 413.2.3 General Residential Fueling Appliances. Residential fueling *appliances* shall be ~~in accordance with Section 413.4~~ listed to CSA/ANSI NGV 5.1. The capacity of a residential fueling appliance (RFA) shall not exceed 5 standard cubic feet per minute (0.14 standard cubic meter/min) of natural gas.

Add new text as follows:

413.2.4 Non-residential fueling appliances. Non-residential fueling appliances shall be listed to CSA/ANSI NGV 5.2. The capacity of a non-residential fueling appliance, listed to that standard as a vehicle fueling appliance (VFA), shall not exceed 10 standard cubic feet per minute (0.28 standard cubic meter/min) of natural gas.

[F] 413.3 Location of dispensing operations and equipment. Compression, storage and dispensing *equipment* shall be located outdoors, above ground.

Exceptions:

1. Compression, storage or dispensing *equipment* is not prohibited in buildings where such buildings are of noncombustible construction as set forth in the International Building Code and are unenclosed for not less than three-quarters of their perimeter.
2. Compression, storage and dispensing *equipment* is allowed to be located indoors or in vaults in accordance with the International Fire Code.

[F] 413.3.1 Location on property. In addition to the fuel-dispensing requirements of the International Fire Code, compression, storage and dispensing *equipment* not located in vaults complying with the International Fire Code and other than residential fueling appliances shall not be installed:

1. Beneath power lines.
2. Less than 10 feet (3048 mm) from the nearest building or property that could be built on, public street, sidewalk or source of ignition.

Exception: Dispensing *equipment* need not be separated from canopies that provide weather protection for the dispensing *equipment* and are constructed in accordance with the International Building Code.

3. Less than 25 feet (7620 mm) from the nearest rail of any railroad track.

4. Less than 50 feet (15 240 mm) from the nearest rail of any railroad main track or any railroad or transit line where power for train propulsion is provided by an outside electrical source, such as third rail or overhead catenary.
5. Less than 50 feet (15 240 mm) from the vertical plane below the nearest overhead wire of a trolley bus line.

Revise as follows:

[F] 413.4 Residential fueling appliance installation. Residential fueling *appliances* shall be installed in accordance with Sections 413.4.1 through 413.4.3, requirements of CSA/ANSI NGV 5.1, manufacturer installation instructions, and Section 2308 of the International Fire Code for RFAs.

Delete without substitution:

~~**[F] 413.4.1 Listing and installation.** Residential fueling appliances shall be listed in accordance with ANSI NGV 5.1. Residential fueling appliances shall be installed in accordance with the appliance manufacturer's installation instructions.~~

~~**[F] 413.4.2 Gas connection.** Residential fueling appliances shall not be rigidly connected to the gas supply piping.~~

~~**[F] 413.4.3 Indoor installation.** A residential fueling appliance installed indoors or used for indoor fueling shall comply with all of the following:~~

1. ~~The capacity shall not exceed 5 cubic feet per minute (0.14 m³/min) of natural gas.~~
2. ~~Fuel gas from the pressure relief and blowdown systems shall be vented to the outdoors.~~
3. ~~A methane gas detector shall be installed in the room or space containing the appliance or where fueling occurs and shall be located not lower than 6 inches (152 mm) from the highest point in the room or space. The detector shall be set to activate at one-fifth of the lower limit of flammability of natural gas and shall be interlocked with the residential fuel appliance to stop or prevent its operation upon activation. The detector shall have an audible or visible alarm.~~
4. ~~The capacity of a residential fueling appliance installed outdoors for outdoor fueling shall not exceed 10 feet cubic per minute (0.28 m³/min) of natural gas. Residential fueling appliances located outdoors shall be installed on a firm, noncombustible base.~~

Add new text as follows:

413.5 Non-residential fueling appliance installation. Non-residential fueling appliances shall be installed in accordance with requirements for vehicle fueling appliances (VFA) in CSA/ANSI NGV 5.2, manufacturer installation instructions, and Section 2308 of the International Fire Code for VFAs.

Revise as follows:

~~**[F] 413.5-413.6 Private fueling of motor vehicles.** Self-service CNG-dispensing systems, including key, code and card lock dispensing systems, shall be limited to the filling of permanently mounted fuel containers on CNG-powered vehicles.~~

In addition to the requirements in the International Fire Code, the owner of a self-service CNG-dispensing facility shall ensure the safe operation of the system and the training of users.

~~**[F] 413.6-413.7 Pressure regulators.** Pressure regulators shall be designed, installed or protected so their operation will not be affected by the elements (freezing rain, sleet, snow, ice, mud or debris). This protection is allowed to be integral with the regulator.~~

~~**[F] 413.7-413.8 Valves.** *Piping to equipment* shall be provided with a remote manual shutoff valve. Such valve shall be provided with ready access.~~

~~**[F] 413.9-413.10 Discharge of CNG from motor vehicle fuel storage containers.** The discharge of CNG from motor vehicle fuel cylinders for the purposes of maintenance, cylinder certification, calibration of dispensers or other activities shall be in accordance with this section. The discharge of CNG from motor vehicle fuel cylinders shall be accomplished through a closed transfer system or an *approved* method of atmospheric venting in accordance with Section 413.9.1 or 413.9.2.~~

[F] ~~413.8-413.9~~ Emergency shutdown control. An emergency shutdown device shall be located within 75 feet (22 860 mm) of, but not less than 25 feet (7620 mm) from, dispensers and shall also be provided in the compressor area. Upon activation, the emergency shutdown system shall automatically shut off the power supply to the compressor and close valves between the main gas supply and the compressor and between the storage containers and dispensers.

[F] ~~413.9.1-413.10.1~~ Closed transfer system. A documented procedure that explains the logical sequence for discharging the cylinder shall be provided to the code official for review and approval. The procedure shall include what actions the operator will take in the event of a low-pressure or high-pressure natural gas release during the discharging activity. A drawing illustrating the arrangement of *pipng*, regulators and *equipment* settings shall be provided to the code official for review and approval. The drawing shall illustrate the *pipng* and regulator arrangement and shall be shown in spatial relation to the location of the compressor, storage vessels and emergency shutdown devices.

[F] ~~413.9.2-413.10.2~~ Atmospheric venting. Atmospheric venting of motor vehicle fuel cylinders shall be in accordance with Sections 413.9.2.1 through 413.9.2.6.

[F] ~~413.9.2.1-413.10.2.1~~ Plans and specifications. A drawing illustrating the location of the vessel support, *pipng*, the method of grounding and bonding, and other requirements specified herein shall be provided to the code official for review and approval.

[F] ~~413.9.2.2-413.10.2.2~~ Cylinder stability. A method of rigidly supporting the vessel during the venting of CNG shall be provided. The selected method shall provide not less than two points of support and shall prevent horizontal and lateral movement of the vessel. The system shall be designed to prevent movement of the vessel based on the highest gas-release velocity through valve orifices at the vessel's rated pressure and volume. The structure or appurtenance shall be constructed of *noncombustible materials*.

[F] ~~413.9.2.3-413.10.2.3~~ Separation. The structure or appurtenance used for stabilizing the cylinder shall be separated from the site *equipment*, features and exposures and shall be located in accordance with Table 413.9.2.3.

**[F] TABLE ~~413.9.2.3-413.10.2.3~~
SEPARATION DISTANCE FOR ATMOSPHERIC VENTING OF CNG**

EQUIPMENT OR FEATURE	MINIMUM SEPARATION (feet)
Buildings	25
Building openings	25
Lot lines	15
Public ways	15
Vehicles	25
CNG compressor and storage vessels	25
CNG dispensers	25

For SI: 1 foot = 304.8 mm.

[F] ~~413.9.2.6-413.10.2.6~~ Signage. Approved NO SMOKING signs shall be posted within 10 feet (3048 mm) of the cylinder support structure or appurtenance. *Approved* CYLINDER SHALL BE BONDED signs shall be posted on the cylinder support structure or appurtenance.

[F] ~~413.9.2.4-413.10.2.4~~ Grounding and bonding. The structure or appurtenance used for supporting the cylinder shall be grounded in accordance with NFPA 70. The cylinder valve shall be bonded prior to the commencement of venting operations.

[F] ~~413.9.2.5-413.10.2.5~~ Vent tube. A vent tube that will divert the gas flow to the atmosphere shall be installed on the cylinder prior to the commencement of the venting and purging operation. The vent tube shall be constructed of pipe or tubing materials *approved* for use with CNG in accordance with the International Fire Code. The vent tube shall be capable of dispersing the gas not less than 10 feet (3048 mm) above grade level. The vent tube shall not be provided with a rain cap or other feature that would limit or obstruct the gas flow.

At the connection fitting of the vent tube and the CNG cylinder, a *listed* bidirectional detonation flame arrester shall be provided.

Update standard(s) as follows:

ANSI

American National Standards
Institute
25 West 43rd Street
New York NY 10036
US

CSA/ANSI NGV 5.1-20152016:

Residential Fueling Appliances

CSA/ANSI NGV 5.2-2017:

Vehicle Fueling Appliances (VFA)

Reason:

This proposal adopts “residential fueling appliance” (RFA) and light-commercial “vehicle fueling appliance” (VFA) coverage for listed appliances from ANSI-recognized standards CSA/ANSI NGV 5.1 and CSA/ANSI NGV 5.2, respectively, and applies installation requirements from those standards, manufacturer installation instructions, and proposed parallel requirements to go into the International Fire Code, Section 2308. Requirements in the two CSA standards cover design, installation, labeling, and other requirements for these two classes of listed appliances and differentiate fueling appliances based on input flow rates and other requirements applicable to residential occupancies in the case of NGV 5.1 and light-commercial occupancies in the case of NGV 5.2. RFA coverage is already found in IFGC Section 413; VFA coverage is proposed as new coverage in the IFGC and IFC.

NFPA 52-2016 already defines and differentiates RFAs and VFAs based on limitations on input flow capacities: 5 SCFM for RFAs and 10 SCFM for VFAs for which coverage is now proposed for both the IFGC and IFC. Parallel coverage RFAs and VFAs is proposed to a new edition of NFPA 52 (2019 edition); however, final action on those proposals has not been taken at the time of the submission of this proposal.

Cost Impact

The code change proposal will not increase or decrease the cost of construction .

The proposal addresses appliance requirements, including installation requirements, unrelated to facility construction.

Analysis: A review of the standards proposed for inclusion in the code, CSA/ANSI NGV 5.2—2017 and CSA/ANSI NGV 5.1-16, with regard to the ICC criteria for referenced standards (Section 3.6 of CP#28) will be posted on the ICC website on or before April 2, 2018.

Internal ID: 2009

FG23-18

IFGC: 602.1, 602.2, 603.1, 604.1, 605.1, 608.1, 609.1, 610.1, 613.1, 617.1, 618.1, 620.1, 621.1, 622.1, 623.1, 624.1, 625.1, 626.1, 627.1, 628.1, 630.1, 636.1

Proponent: Shannon Corcoran, representing CSA Group (shannon.corcoran@csagroup.org)

2018 International Fuel Gas Code

Revise as follows:

602.1 General. Decorative appliances for installation in *approved* solid fuel-burning fireplaces shall be ~~tested-listed~~ in accordance with ANSI Z21.60/CSA 6.26 and shall be installed in accordance with the manufacturer's instructions. Manually lighted natural gas decorative appliances shall be ~~tested-listed~~ in accordance with ANSI Z21.84.

602.2 Flame safeguard device. Decorative appliances for installation in approved solid fuel-burning fireplaces, with the exception of those ~~tested-listed~~ in accordance with ANSI Z21.84, shall utilize a direct ignition device, an ignitor or a pilot flame to ignite the fuel at the main burner, and shall be equipped with a flame safeguard device. The flame safeguard device shall automatically shut off the fuel supply to a main burner or group of burners when the means of ignition of such burners becomes inoperative.

603.1 General. Log lighters shall be ~~tested-listed~~ in accordance with CSA 8 and installed in accordance with the manufacturer's instructions.

604.1 General. Vented gas fireplaces shall be ~~tested-listed~~ in accordance with ANSI Z21.50/CSA 2.22, shall be installed in accordance with the manufacturer's instructions and shall be designed and equipped as specified in Section 602.2.

605.1 General. Vented gas fireplace heaters shall be installed in accordance with the manufacturer's instructions, shall be ~~tested-listed~~ in accordance with ANSI Z21.88/CSA 2.33 and shall be designed and equipped as specified in Section 602.2.

608.1 General. Vented wall furnaces shall be ~~tested-listed~~ in accordance with ANSI Z21.86/CSA 2.32 and shall be installed in accordance with the manufacturer's instructions.

609.1 General. Floor furnaces shall be ~~tested-listed~~ in accordance with ANSI Z21.86/CSA 2.32 and shall be installed in accordance with the manufacturer's instructions.

610.1 General. Duct furnaces shall be ~~tested-listed~~ in accordance with ANSI Z83.8/CSA 2.6 or UL 795 and shall be installed in accordance with the manufacturer's instructions.

613.1 General. Clothes dryers shall be ~~tested-listed~~ in accordance with ANSI Z21.5.1/CSA 7.1 or ANSI Z21.5.2/CSA 7.2 and shall be installed in accordance with the manufacturer's instructions.

617.1 General. Pool and spa heaters shall be ~~tested-listed~~ in accordance with ANSI Z21.56/CSA 4.7 and shall be installed in accordance with the manufacturer's instructions.

618.1 General. Forced-air warm-air furnaces shall be ~~tested-listed~~ in accordance with ANSI Z21.47/CSA 2.3 or UL 795 and shall be installed in accordance with the manufacturer's instructions.

620.1 General. Unit heaters shall be ~~tested-listed~~ in accordance with ANSI Z83.8/CSA 2.6 and shall be installed in accordance with the manufacturer's instructions.

621.1 General. Unvented room heaters shall be ~~tested-listed~~ in accordance with ANSI Z21.11.2 and shall be installed in accordance with the conditions of the listing and the manufacturer's instructions. Unvented room heaters utilizing fuels other than fuel gas shall be regulated by the International Mechanical Code.

622.1 General. Vented room heaters shall be ~~tested-listed~~ in accordance with ANSI Z21.86/CSA 2.32, shall be designed and equipped as specified in Section 602.2 and shall be installed in accordance with the manufacturer's instructions.

623.1 Cooking appliances. Cooking appliances that are designed for permanent installation, including ranges, ovens, stoves, broilers, grills, fryers, griddles, hot plates and barbecues, shall be ~~tested-listed~~ in accordance with ANSI

Z21.1, ANSI Z21.58/CSA 1.6 or ANSI Z83.11/CSA 1.8 and shall be installed in accordance with the manufacturer's instructions.

624.1 General. Water heaters shall be ~~tested-listed~~ in accordance with ANSI Z21.10.1/CSA 4.1 ~~and or~~ ANSI Z21.10.3/CSA 4.3 and shall be installed in accordance with the manufacturer's instructions. Water heaters utilizing fuels other than fuel gas shall be regulated by the International Mechanical Code.

625.1 General. Refrigerators shall be ~~tested-listed~~ in accordance with ANSI Z21.19/CSA 1.4 and shall be installed in accordance with the manufacturer's instructions. Refrigerators shall be provided with adequate clearances for ventilation at the top and back, and shall be installed in accordance with the manufacturer's instructions. If such instructions are not available, not less than 2 inches (51 mm) shall be provided between the back of the refrigerator and the wall and not less than 12 inches (305 mm) above the top.

626.1 General. Gas-fired toilets shall be ~~tested-listed~~ in accordance with ANSI Z21.61 and installed in accordance with the manufacturer's instructions.

627.1 General. Gas-fired air-conditioning appliances shall be ~~tested-listed~~ in accordance with ANSI Z21.40.1/~~CGA-CSA~~ 2.91 or ANSI Z21.40.2/~~CGA-CSA~~ 2.92 and shall be installed in accordance with the manufacturer's instructions.

628.1 General. Illuminating appliances shall be ~~tested-listed~~ in accordance with ANSI Z21.42 and shall be installed in accordance with the manufacturer's instructions.

630.1 General. Infrared radiant heaters shall be ~~tested-listed~~ in accordance with ANSI Z83.19 or Z83.20 and shall be installed in accordance with the manufacturer's instructions.

636.1 General. Permanently fixed-in-place outdoor decorative appliances shall be ~~tested-listed~~ in accordance with ANSI Z21.97 and shall be installed in accordance with the manufacturer's instructions.

Reason:

This proposal is intended to require the appliance to be listed by an organization acceptable to the code official. Listed, as defined in Section 202 includes a requirement that an approved agency posts the certification record in a public forum which is available to the Authority Having Jurisdiction for verification purposes. Testing, according to Section 301.4.1, does not require the testing agency to provide a listing or approved products and appliances.

Cost Impact

The code change proposal will not increase or decrease the cost of construction .

Manufacturers of gas-fired appliances and gas regulators currently have their products listed by nationally recognized testing laboratories and/or nationally recognized certification bodies. Changing the term "tested" to "listed" will not affect the cost to install these products.

Internal ID: 1155

FG24-18

IFGC: 611.2

Proponent: James Ranfone, representing American Gas Association (jranfone@aga.org)

2018 International Fuel Gas Code

Revise as follows:

611.2 Installation. *Nonrecirculating direct-fired industrial air heaters* shall not be used to supply any area containing sleeping quarters. *Nonrecirculating direct-fired industrial air heaters* shall be installed only in industrial or commercial occupancies. ~~*Nonrecirculating direct-fired industrial air heaters* shall be permitted to provide ventilation air.~~

Reason:

Section 611.1 requires that this appliance be installed in accordance with the manufacturers installation instructions which will place limits on their use. The deletion would coordinate the 2018 National Fuel Gas Code.

Cost Impact

The code change proposal will not increase or decrease the cost of construction .

The code's installation requirements are not impacted by the change.

Internal ID: 1391

FG25-18

IFGC: 612.2

Proponent: James Ranfone, representing American Gas Association (jranfone@aga.org)

2018 International Fuel Gas Code

Revise as follows:

612.2 Location. ~~Recirculating direct-fired industrial air heaters shall be installed only in industrial and commercial occupancies. Recirculating direct-fired air heaters shall not serve any area containing sleeping quarters. Recirculating direct-fired industrial air heaters shall not be installed in hazardous locations or in buildings that contain flammable solids, liquids or gases, explosive materials or substances that can become toxic when exposed to flame or heat.~~

Reason:

Section 612.3 requires that this appliance be installed in accordance with the manufacturers installation instructions which will place limits on their use. The deletion would coordinate the 2018 National Fuel Gas Code.

Cost Impact

The code change proposal will not increase or decrease the cost of construction .

The code's installation requirements are not impacted by this change since section 612.3 would still determine where these heaters can be installed.

Internal ID: 1395

FG26-18

IFGC: 614.6, [M]614.6.1 (New)

Proponent: Brent Ursenbach, representing Salt Lake County Planning and Development Services
(bursenbach@slco.org)

THIS CODE CHANGE PROPOSAL HAS BEEN PLACED ON THE IMC COMMITTEE AGENDA. PLEASE SEE THE IMC HEARING ORDER.

2018 International Fuel Gas Code

Revise as follows:

[M] 614.6 Makeup air. Installations exhausting more than 200 cfm (0.09 m³/s) shall be provided with makeup air. ~~Where a closet is designed for the installation of a clothes dryer, an opening having an area of not less than 100 square inches (645 mm²) for makeup air shall be provided in the closet enclosure, or makeup air shall be provided by other approved means.~~

Add new text as follows:

[M]614.6.1 Closet Installation. Where a closet is designed for the installation of a clothes dryer, an opening having an area of not less than 100 square inches (645 mm²) for makeup air shall be provided in the closet enclosure, or makeup air shall be provided by other approved means.

Reason:

Section 614.6, Makeup air addresses two different conditions. First, all dryers over 200 CFM, typically a commercial dryer, require makeup air. Second, if any dryer is located in a closet, there must be an opening allowing makeup air into the closet, to replace air exhausted by the dryer. This requirement applies to any dryer installed in a closet, not only 200 CFM dryers. This proposal simply breaks the section into 2 parts, eliminating any confusion.

Cost Impact

The code change proposal will not increase or decrease the cost of construction .

This proposal simply divides a single paragraph into two. No additional requirements are added to the code.

Internal ID: 1470

FG27-18

IFGC: 621.2

Proponent: Craig Conner, representing self (craig.conner@mac.com)

2018 International Fuel Gas Code

Revise as follows:

621.2 Prohibited use. One or more unvented room heaters shall not be used as the sole source of comfort heating in a *dwelling unit*. Unvented room heaters shall not be installed within new dwelling units.

Reason:

New codes are making new dwelling units significantly tighter. Unvented room heaters are vented directly into the conditioned space. Heating combustion products should not be vented directly into the conditioned space of tight dwellings.

Unvented room heaters should not be used as a primary source of heating. Vented versions of the unvented heaters are commonly available.

In the last code cycle provisions to allow unvented alcohol burning devices were twice rejected in the ICC process. Likewise, unvented gas room heaters should not be allowed.

Cost Impact

The code change proposal will increase the cost of construction .

Vented gas heaters are commonly available. These cost more due the need to provide a vent.

Many builders will not install unvented room heaters due to concerns with NO_x (nitrus oxides), liability, etc. Since they are already choosing not to install unvented heaters, this would have no impact on those builders.

Internal ID: 1788

FG28-18

IFGC: 623.2

Proponent: Guy McMann, Jefferson County, Colorado, representing Colorado Association of Plumbing and Mechanical Officials (CAPMO) (gcmcmann@jeffco.us)

2018 International Fuel Gas Code

Revise as follows:

623.2 Prohibited location. Cooking appliances designed, tested, *listed* and *labeled* for use in commercial occupancies shall not be installed within dwelling units or within any area where domestic cooking operations occur.

Exceptions:

1. Appliances that are also listed as domestic cooking appliances.
2. ~~Where the installation is designed by a licensed Professional Engineer, in compliance with the manufacturer's installation instructions.~~

Reason:

The new exception #2 was added because at least one state government modified the IFGC to permit commercial cooking appliances to be installed in dwellings if an engineer designed the job. This was done solely because some consumers were demanding commercial cooking appliances in their homes. The marketplace has already taken care of this demand because appliance manufacturers offer many commercial style appliances that are dual listed as both commercial and household appliances. This is already addressed in exception #1. There is no reason to risk occupant safety by installing commercial appliances in dwellings when there are many appliances that are listed for dwelling installation and have the commercial features and capacities that consumers want. Exception # 2 permits cooking appliances listed only for commercial applications to be installed in a dwelling if a licensed professional Engineer designs the kitchen installation and follows the manufacturers installation instructions. This is a contradictory statement because the manufacturers instructions will likely prohibit commercial appliances in dwellings. This is also contrary to Section 301.3 which requires appliances to be listed and labeled for the application in which they are used. Commercial ranges are not listed and labeled for use in a dwelling , therefore it is a code violation whether or not it has the blessing of the design engineer. Some appliance nameplates state that a commercial appliance is not intended for domestic use, so installation in a dwelling would be a violation of the manufacturers instructions as well as Section 301.3. Commercial cooking appliances are not suitable or even safe within dwellings because they require large clearances to combustibles, might require non-combustible floors and require exhaust systems similar to what is required in restaurants. This exception is not only unnecessary, it allows appliance installation instructions, Section 301.3 and the appliance listing to be violated.

Cost Impact

The code change proposal will not increase or decrease the cost of construction .

This is strictly editorial.

Internal ID: 939

FG29-18

IFGC: 620.4

Proponent: James Ranfone, representing American Gas Association (jranfone@aga.org)

2018 International Fuel Gas Code

Revise as follows:

620.4 Clearance. Suspended-type unit heaters shall be installed with clearances to *combustible materials* of not less than 18 inches (457 mm) at the sides, 12 inches (305 mm) at the bottom and 6 inches (152 mm) above the top where the unit heater has an internal draft hood or 1 inch (25 mm) above the top of the sloping side of the vertical draft hood. ~~Floor-mounted type unit heaters shall be installed with clearances to *combustible materials* at the back and one side only of not less than 6 inches (152 mm). Where the flue gases are vented horizontally, the 6-inch (152 mm) clearance shall be measured from the draft hood or vent instead of the rear wall of the unit heater. Floor-mounted type unit heaters shall not be installed on combustible floors unless *listed* for such installation.~~

Clearances for servicing all unit heaters shall be in accordance with the manufacturer's installation instructions.

Exception: Unit heaters *listed* for reduced *clearance* shall be permitted to be installed with such clearances in accordance with their listing and the manufacturer's instructions.

Reason:

We are unaware of any newly manufactured floor-mounted unit heaters. The deletion would coordinate the 2018 National Fuel Gas Code.

Cost Impact

The code change proposal will not increase or decrease the cost of construction .

New types of these unit heaters no longer exist.

Internal ID: 1389

2018 GROUP A – PROPOSED CHANGES TO THE INTERNATIONAL MECHANICAL CODE

MECHANICAL CODE COMMITTEE

Robert J. Schutz, PE, PS, CBO, Chair

Retired
City of Columbus (OHIO)
Columbus, OH

Brent Ursenbach, CBO, LEED-AP, Vice Chair

Mechanical & Energy Code Official
Salt Lake County, Planning & Dev. Services
Salt Lake City, UT

Edward Allat IV

Fire Subcode Official
Hillsborough Township
Somerville, NJ

David C. Beahm, CBO

Building Official
County of Warren
Front Royal, VA

Donald H. Chaisson, LEED AP

Rep: Air Conditioning Association of New England
Sr. Field Representative
APA HVAC Technologies
Canton, MA

Carl Chretien, LPI

Rep: National Association of Home Builders
CEO, President
Chretien Construction Inc.
Saco, ME

Joshua F. Clark

Director of Sales
Rath Communications
Sussex, WI

Thomas R. Frost

3rd Party Commissioning
Silverthorne, CO

Frank Goodard

Commercial/Residential Building Inspector
SafeBuilt of Colorado
Firestone, CO

Eli Howard, III

Executive Director, Technical Services
Sheet Metal & Air Conditioning National Contractors
Association
Chantilly, VA

Amanda Hickman

President/Consultant
The Hickman Group
Plantation, FL

Marshall Kaminer, PE

Executive Engineer of Technical Affairs & Code
Development
New York City Department of Buildings
New York, NY

Jason Phelps

Plans Examiner II
City of Hillsboro
Hillsboro, OR

Janine Snyder

Building Inspector IV
City of Thornton
Thornton, CO

Paolo Toschi

Senior Permitting Service Specialist
Montgomery County Government Department of
Permitting Services
Division of Building Construction
Rockville, MD

Staff Liaison:

Gregg Gress

Senior Technical Staff
International Code Council
Central Regional Office
Country Club Hill, IL

TENTATIVE ORDER OF DISCUSSION 2018 PROPOSED CHANGES TO THE INTERNATIONAL MECHANICAL CODE

The following is the tentative order in which the proposed changes to the code will be discussed at the public hearings. Proposed changes which impact the same subject have been grouped to permit consideration in consecutive changes.

Proposed change numbers that are indented are those which are being heard out of numerical order. Indentation does not necessarily indicate that one change is related to another. Proposed changes may be grouped for purposes of discussion at the hearing at the discretion of the chair. Note that some M code change proposals may not be included on this list, as they are being heard by another committee.

NUMBER NOT USED:

M102

M1-18	M32-18	M65-18	M97-18
FG1-18	M33-18	M66-18	M98-18
M2-18	M34-18	M67-18	F79-18 Part II
P1-18 Part III	M35-18	M68-18	M99-18
M3-18	M36-18	M69-18	M100-18
M4-18	M37-18	M70-18	M101-18
M5-18	FG26-18	M71-18	E15-18 Part II
M6-18	M38-18	M72-18	M103-18
M7-18	M39-18	M73-18	M104-18
M8-18	M40-18	M74-18	M105-18
M9-18	M41-18	M75-18	M106-18
M10-18	M42-18	M76-18	M107-18
M11-18	M43-18	M77-18	M108-18
M12-18	M44-18	M78-18 Part I	M109-18
M13-18	M45-18	M78-18 Part II	M110-18
M14-18	M46-18	M79-18	M111-18
M15-18 Part I	M47-18	M80-18	M112-18
G116-18 Part II	M48-18	M81-18	M113-18
M15-18 Part II	M49-18	M82-18	M114-18
M16-18	M50-18	M83-18	M115-18
M17-18	M51-18	M84-18	M116-18
M18-18	M52-18	M85-18	M117-18
M19-18	M53-18 Part I	M86-18 Part I	M118-18
M20-18	M53-18 Part II	M86-18 Part II	M119-18 Part I
M21-18	M54-18	M87-18	M119-18 Part II
M22-18	M55-18	M88-18	M120-18
M23-18	M56-18	M89-18	M121-18
M24-18	M57-18	M90-18	M122-18
M25-18	M58-18	M91-18	M123-18
M26-18	M59-18	F83-18 Part II	M124-18
M27-18	M60-18	M92-18	M125-18
M28-18	M61-18	M93-18	M126-18
M29-18	M62-18	M94-18	M127-18
M30-18	M63-18	M95-18	M128-18
M31-18	M64-18	M96-18	

M1-18

IMC: 202 (New), 202

Proponent: Andrew Klein, representing Self Storage Association (andrew@asklein.com)

2018 International Mechanical Code

Add new definition as follows:

DEDICATED STORAGE AREA. The floor area within an occupiable space that is designated solely for storage.

Revise as follows:

BREATHING ZONE. The region within an occupied space between planes 3 and 72 inches (76 and 1829 mm) above the floor and more than 2 feet (610 mm) from the walls of the space ~~or,~~ from dedicated storage areas and from fixed air-conditioning equipment.

Reason:

This proposal clarifies the application of Section 403.3.1.1, regarding required minimum outdoor airflow rates. The current code language is inconsistently applied when there are fixed storage areas that do not change without a permit. Examples of such floor areas may include those dedicated to high-piled rack storage, self-storage facility units that are not fully partitioned off from interior corridors, and other floor areas that are designated solely for storage.

Ignoring the volume taken up by storage and the thermal mass it provides in helping with temperature regulation results in the oversizing of HVAC equipment, increasing energy use and limiting the effectiveness of humidity control that properly-sized systems provide. By adding a new defined term, dedicated storage area, the minimum outdoor airflow rates for occupiable space with dedicated storage areas can be properly calculated.

Cost Impact

The code change proposal will decrease the cost of construction .

In buildings where there are fixed or designated storage areas, this proposal will reduce the minimum required outdoor airflow rate and thus decrease the initial cost of HVAC equipment and also reduce the operational cost of maintaining conditioned air within the building.

Internal ID: 1671

M2-18

IMC: SECTION 202, 202 (New)

Proponent: Brent Ursenbach, representing Salt Lake County Planning and Development Services
(bursenbach@slco.org)

2018 International Mechanical Code

SECTION 202 GENERAL DEFINITIONS

Add new definition as follows:

INDIRECT EVAPORATIVE COOLING. The evaporative cooling process where water evaporates into a secondary air stream, removing heat from a primary air stream utilizing a heat exchanger.

DIRECT EVAPORATIVE COOLING. The evaporative cooling process where water evaporates directly into the air stream, reducing the air's dry-bulb temperature and raising its humidity level.

Reason:

These two definitions are proposed to clarify the difference between direct and indirect evaporative cooling. Additionally, these definitions are proposed as part of this proponent's proposal to IMC 602.2 and 603.5.1.

Cost Impact

The code change proposal will not increase or decrease the cost of construction.

These definitions simply identify the difference between two types of evaporative cooling.

Internal ID: 2002

M3-18

IMC: 202

Proponent: Charles Stock, representing Spunstrand Inc

2018 International Mechanical Code

Revise as follows:

THERMAL RESISTANCE (R-value). A measure of the ability to retard the flow of heat and represented in units of $\text{Ft}^2 \times \text{h} / \text{BTU}$ or $\text{K} \times \text{m}^2 / \text{W}$. The R-value is the reciprocal of thermal conductance.

Reason:

In recent years specifying engineers, third party product listing groups, builders, and end users have all been bombarded with questionable thermal performance claims by product manufacturers. All of this recent noise has left many wondering if they are getting the performance their projects actually require. This proposed addition of recognized/acceptable units for R-value's is an additional step towards clarifying and unifying what is and what is not actual a trusted measure of thermal performance properties. These units are published for clarification in the International Energy Conservation code for this very reason. Failing to add this clarification to the International Mechanical Code could result in the continued use of misleading or insufficiently insulated products being used in the market.

Bibliography:

2015 ICC International Energy Conservation Code, ICC, 2015

Cost Impact

The code change proposal will not increase or decrease the cost of construction .

By adding further clarification, this proposal should simply assist in making sure that expected performance and value already being purchased is actually being delivered.

Internal ID: 1430

M4-18

IMC: 202

Proponent: Julius Ballanco, JB Engineering and Code Consulting, P.C., representing Daikin US (JBENGINEER@aol.com)

2018 International Mechanical Code

Revise as follows:

FLAMMABILITY CLASSIFICATION (REFRIGERANT). ~~Refrigerants shall be assigned to one of the three classes 1, 2 or 3 in accordance with ASHRAE 34. For Classes 2 and 3, the heat of combustion shall be calculated assuming that combustion products are in the gas phase and in their most stable state. The alphabetical/numerical designation used to identify the flammability of refrigerants.~~

~~**Class 1.** Refrigerants that do not show flame propagation when tested in air at 14.7 psia (101 kPa) and 140°F (60°C). Indicates a refrigerant with no flame propagation.~~

~~**Class 2L.** Indicates a refrigerant with lower flammability and lower burning velocity.~~

~~**Class 2.** Refrigerants having a lower flammability limit (LFL) of more than 0.00625 pound per cubic foot (0.10 kg/m³) at 140°F (60°C) and 14.7 psia (101 kPa) and a heat of combustion of less than 8169 Btu/lb (19 000 kJ/kg). Indicates a refrigerant with lower flammability.~~

~~**Class 3.** Refrigerants that are highly flammable, having a LFL of less than or equal to 0.00625 pound per cubic foot (0.10 kg/m³) at 140°F (60°C) and 14.7 psia (101 kPa) or a heat of combustion greater than or equal to 8169 Btu/lb (19 000 kJ/kg). Indicates a refrigerant with higher flammability.~~

~~**REFRIGERANT SAFETY CLASSIFICATIONS.** Groupings—The alphabetical/numerical designation that indicate both the toxicity and flammability classes in accordance with Section 1103.1. The classification group is made up of a letter (A or B) that indicates the toxicity class, followed by a number (1, 2 or 3) that indicates the flammability class. Refrigerant blends are similarly classified, based on the compositions at their worst cases of fractionation, as separately determined for toxicity and flammability. In some cases, the worst case of fractionation is the original formulation of refrigerants.~~

~~**TOXICITY CLASSIFICATION CLASSIFICATION (REFRIGERANT).** Refrigerants shall be classified for toxicity in one of two classes in accordance with ASHRAE 34. An alphabetic designation used to identify the toxicity of refrigerants. Class A indicates a refrigerant with lower toxicity. Class B indicates a refrigerant with higher toxicity.~~

Reason:

The current definitions of “flammability classification” and “toxicity classification” are improper since these contain mandatory code requirements. The definitions should only define the term, not contain requires with the use of the word “shall.” The definition of refrigerant safety classifications is incorrect because ASHRAE 34 was revised regarding the means of identifying the classification of refrigerants.

The classification or group of refrigerant is an alphabetical/numerical designation that is used to identify the flammability and toxicity of a given refrigerant. There were two new classifications added to ASHRAE 34, A2L and B2L. These designations were previously subclasses. Now they are a full class of refrigerant.

Cost Impact

The code change proposal will not increase or decrease the cost of construction .

These are definition changes.

Internal ID: 913

M5-18

IMC: 202

Proponent: Mark Fasel, representing Viega LLC (mark.fasel@viega.us)

2018 International Mechanical Code

Revise as follows:

PRESS-CONNECT JOINT. A permanent mechanical joint incorporating an elastomeric seal or an elastomeric seal and corrosion – resistant grip or bite ring. The joint is made with a pressing tool and jaw or ring approved by the fitting manufacturer.

Reason:

This change is simply editorial to provide clarity as this component of the "press-connect joint", if present, is often referred to as grip ring and, or bite ring by manufacturer's as well as installers. This change will eliminate any confusion that occurs when determining if a component referenced as a bite ring in technical specifications still meets the definition provided in the International codes. Grip and Bite rings serve the same purpose for permanent mechanical attachment to piping or tubing.

Cost Impact

The code change proposal will not increase or decrease the cost of construction .

The proposal to revise the definition of press-connect joint clarifies that the design of a press-connect joint may incorporate a grip or bite ring. This clarification removes any confusion in terminology of the internal components by the manufacturer as they are sometimes labeled as bite ring or grip ring. This changes does not increase cost of construction, testing or listings, it is for clarification purposes only..

Internal ID: 740

M6-18

IMC: 301.18

Proponent: Kelly Cobeen, Wiss Janney Elstner Associates, Inc, representing Federal Emergency Management Agency/Applied Technology Council - Seismic Code Support Committee (KCobeen@wje.com); Michael Mahoney, Federal Emergency Management Agency, representing Federal Emergency Management Agency (mike.mahoney@fema.dhs.gov)

2018 International Mechanical Code

Revise as follows:

301.18 Seismic resistance. Where earthquake loads are applicable in accordance with the International Building Code, mechanical system supports, anchorage, and bracing, shall be designed and installed for ~~the~~ seismic forces in accordance with Chapter 16 of the International Building Code.

Reason:

The added text clarifies the IBC location where specific seismic requirements are defined. This is intended to simply make the seismic design provisions more easily used, consistent with the intent as stated in 2015 NEHRP Recommended Provisions Section 1.1.2, to preserve life safety by maintaining the position of components through anchorage, bracing and strength.

Bibliography:

NEHRP Recommended Seismic Provisions for New Buildings and Other Structures. 2015 Edition (FEMA P-1050-1), Federal Emergency Management Agency, Washington, D.C.

Cost Impact

The code change proposal will not increase or decrease the cost of construction .

The proposals clarifies the intent of the code and does not impose any new requirements that were not already in effect.

Internal ID: 1025

M7-18

IMC: TABLE 305.4

Proponent: Forest Hampton, Lubrizol Advanced Materials, Inc., representing Lubrizol Advanced Materials, Inc.
(forest.hampton@lubrizol.com)

2018 International Mechanical Code

Revise as follows:

**TABLE 305.4
PIPING SUPPORT SPACING^a**

PIPING MATERIAL	MAXIMUM HORIZONTAL SPACING (feet)	MAXIMUM VERTICAL SPACING (feet)
ABS pipe	4	10 ^c
Aluminum pipe and tubing	10	15
Cast-iron pipe ^b	5	15
Copper or copper-alloy pipe	12	10
Copper or copper-alloy tubing	8	10
CPVC pipe or tubing, 1 inch and smaller	3 ^d	10 ^c
CPVC pipe or tubing, 1 ¹ / ₄ -inches and larger	4 ^d	10 ^c
Lead pipe	Continuous	4
PB pipe or tubing	2 ² / ₃ (32 inches)	4
PE-RT 1 inch and smaller	2 ² / ₃ (32 inches)	10 ^c
PE-RT 1 ¹ / ₄ inches and larger	4	10 ^c
PEX tubing 1 inch and smaller	2 ² / ₃ (32 inches)	10 ^c
PEX tubing 1 ¹ / ₄ inches and larger	4	10 ^c
Polypropylene (PP) pipe or tubing, 1 inch and smaller	2 ² / ₃ (32 inches)	10 ^c
Polypropylene (PP) pipe or tubing, 1 ¹ / ₄ inches and larger	4	10 ^c
PVC pipe	4	10 ^c
Steel tubing	8	10
Steel pipe	12	15

For SI: 1 inch = 25.4 mm, 1 foot = 304.8 mm.

- a. See Section 301.18.
- b. The maximum horizontal spacing of cast-iron pipe hangers shall be increased to 10 feet where 10-foot lengths of pipe are installed.
- c. Mid-story guide.
- d. Hanger spacing is calculated at 180°F (82.2°C). For applications with lower temperatures, piping support need not comply with the table where the piping is supported in accordance with the manufacturer's installation instructions and is approved.

Reason:

CPVC piping can use longer support spacing at lower temperatures, but additional tables would add complexity. Allowing a CPVC system to utilize specific manufacturer's instructions under specific conditions and with prior AHJ approval would be of use in some installations. A footnote seems sufficient in those cases.

Cost Impact

The code change proposal will not increase or decrease the cost of construction .

This will not increase the cost of construction as it only adds an additional option for the installer.

Internal ID: 1644

M8-18

IMC: 306.4.2 (New)

Proponent: Guy McMann, representing Colorado Association of Plumbing and Mechanical Officials (CAPMO)
(gmcman@jeffco.us)

2018 International Mechanical Code

Add new text as follows:

306.4.2 Ladder required. Where mechanical equipment or appliances that require servicing are located in under floor spaces that are over 30 inches in depth, access openings to such space shall be equipped with a permanently affixed approved ladder capable of withstanding a 300-pound (136.1 kg) load. Such ladders shall be securely fastened to the structure at the top and bottom, shall have a rung spacing of not less than 14 inches (356 mm) and not less than 18 inches (457 mm) between rails. Ladders constructed of dimensional lumber shall be not less than nominal two by four material. Fasteners shall be in accordance with Table 2304.10.1, Item 16 of the International Building Code for end nailing or other approved fastening methods.

Reason:

The code tells us how to go up but it doesn't tell us how to go down. Ladders constructed of wood in many instances lack the quality in construction to support the weight imposed on them. Often the rungs break exposing the fasteners that can seriously wound the person accessing the ladder. There needs to be a ladder capable of withstanding the repeated use that accessing appliances and equipment in crawlers and under floor spaces require. Many of these spaces are used for storage. The spacing requirements are the same as found in 306.5 along with the loading requirements. This proposal provides much flexibility in construction and would apply to dwellings as well. Guidance for using wood has been provided. Other methods of construction of ladders shall be up for approval by the AHJ.

Cost Impact

The code change proposal will increase the cost of construction .

This requirement may increase the cost as it has not been required to install a ladder in a under floor access opening or under floor space to date although many just do it anyway in a haphazard way.

Internal ID: 209

M9-18

IMC: 307.2.3

Proponent: Darwin Bryant, representing MODERN AC PRODUCTS LLC. (darwinbryant@ymail.com)

2018 International Mechanical Code

Revise as follows:

307.2.3 Auxiliary and secondary drain systems. In addition to the requirements of Section 307.2.1, where damage to any building components could occur as a result of overflow from the *equipment* primary condensate removal system, one of the following auxiliary protection methods shall be provided for each cooling coil or fuel-fired *appliance* that produces condensate:

1. An auxiliary drain pan with a separate drain shall be provided under the coils on which condensation will occur. The auxiliary pan drain shall discharge to a conspicuous point of disposal to alert occupants in the event of a stoppage of the primary drain and the terminus of such drain shall be provided with an insect screen. The pan shall have a minimum depth of 1¹/₂ inches (38 mm), shall be not less than 3 inches (76 mm) larger than the unit, or the coil dimensions in width and length and shall be constructed of corrosion-resistant material. Galvanized sheet steel pans shall have a minimum thickness of not less than 0.0236 inch (0.6010 mm) (No. 24 gage). Nonmetallic pans shall have a minimum thickness of not less than 0.0625 inch (1.6 mm).
2. A separate overflow drain line shall be connected to the drain pan provided with the *equipment*. Such overflow drain shall discharge to a conspicuous point of disposal to alert occupants in the event of a stoppage of the primary drain and the terminus of such drain shall be provided with an insect screen. The overflow drain line shall connect to the drain pan at a higher level than the primary drain connection.
3. An auxiliary drain pan without a separate drain line shall be provided under the coils on which condensate will occur. Such pan shall be equipped with a water-level detection device conforming to UL 508 that will shut off the *equipment* served prior to overflow of the pan. The auxiliary drain pan shall be constructed in accordance with Item 1 of this section.
4. A water-level detection device conforming to UL 508 shall be provided that will shut off the *equipment* served in the event that the primary drain is blocked. The device shall be installed in the primary drain line, the overflow drain line, or in the equipment-supplied drain pan, located at a point higher than the primary drain line connection and below the overflow rim of such pan.

Exception: Fuel-fired appliances that automatically shut down operation in the event of a stoppage in the condensate drainage system.

Reason:

I've been in the hvac industry for over 20 years, and have been called upon time after time from both residential and businesses to find out why water would be coming through the attic onto the rooms below, the main reason for this is not poor installation, it's from "insects" such as "dirt dauber's" making their nest inside the emergency drain line and stopping it up. It does not matter if the unit's have a float switch installed, that only turns off the condenser, which stops making ice, but the evaporator coil is frozen solid when there is ice on the evaporator, and when ice starts to melt, it fills up the emergency drain pan. If the emergency drain line is restricted with some of these pest, water will be overflowing the emergency drain pan, and onto the rooms below. Its very expensive to have all the sheet rock replaced, furniture replaced, and in some instances, even mold starts to grow,

The construction industry is vast, especially in the state of texas. If every contractor, would be required to have a devise in place such as an insect screen it would ensure two (2) things, its extra insurance for the business owner as well as the homeowner, also, if you have such a devise in place, the homeowner would possibly get a discount on their homeowner insurance. For the resale value of a home, its a plus if you have the hvac technicians install these on each unit, therefore having the insect screen on board while installing the new furnace insures the homeowner that all precaution's have been considered in the sale of their home.

The building code forum concerning secondary condensate drains have two (2) purposes. One is to convey

condensate and the other is to warn the occupant that the primary has ceased to function. In order of importance, the secondary trumps the primary in that the secondary is the last chance to prevent an inadvertent release of condensate where it will cause damage. Gravity if available is trustworthy. A switch or pump is not trustworthy. Gravity does not wear out or get stuck but switches and pumps do. A switch or pump that has never operated, located in a dusty hot attic for fourteen (14) years might not work. This shows there is a need for emergency condensate drain line when there is a float switch as long as there is a condensate drain line then it must be protected from insects!









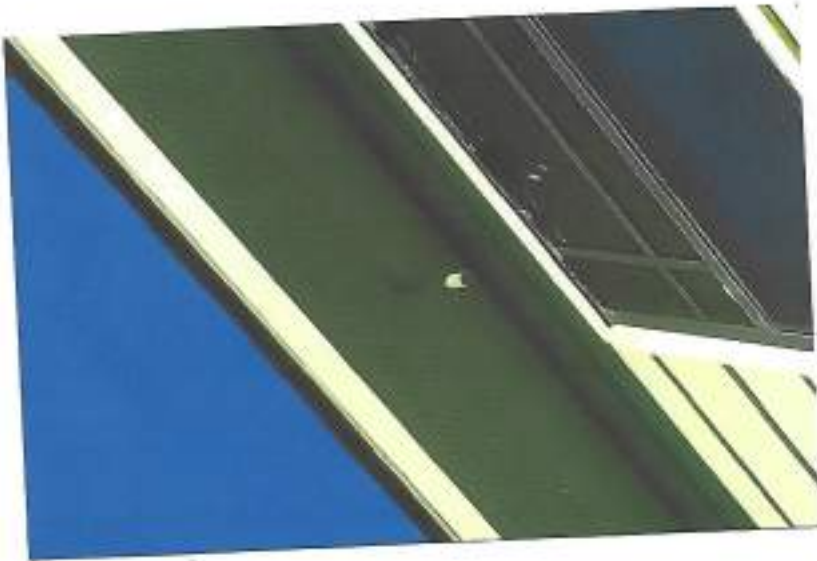



BEFORE



AFTER

Bibliography:

TITLE: PIPEWORKS SERVICES INC.

REPORT: CLOGGED CONDENSATE DRAIN: LEARN HOW TO PREVENT IT

AUTHOR: PAUL GIGLIO JR

YEAR PUBLISHED: 2013

PAGE NUMBER: 2

LINK TO WEBSITE: WWW.PIPEWORKSSERVICES.COM

2CD PAGE, 3RD PARAGRAPH TITLE: WHAT CAUSES CLOGS? DIRT, MOLD PET HAIR AND OTHER DEBRIS THAT SETTLES IN YOUR CONDENSATE PAN GATHERS AT THE DRAIN OPENING AND CAN CLOG THE DRAIN. "INSECTS MAY NEST IN YOUR DRAIN LINE" ESPECIALLY IF IT TERMINATES OUR OUTDOORS, CAUSING AN OBSTRUCTION.

Cost Impact

The code change proposal will increase the cost of construction .

\$ 19.95 PER INSECT SCREEN (HVAC DISTRIBUTOR-WHOLESALE)

\$ 34.95 (RETAIL STORES -HOME DEPOT, LOWES, ETC)

\$ 125.00 CONTRACT LABOR (RESIDENTIAL & BUSINESS)

Internal ID: 1478

M10-18

IMC: 307.1, 307.1.2 (New), 307.2.3.3 (New)

Proponent: Guy McMann, representing Colorado Association of Plumbing and Mechanical Officials (CAPMO)
(gcmcmann@jeffco.us)

2018 International Mechanical Code

307.1 Fuel-burning appliances. Liquid *combustion* by-products of condensing appliances shall be collected and discharged to an *approved* plumbing fixture or disposal area in accordance with the manufacturer's installation instructions. Condensate piping shall be of *approved* corrosion-resistant material and shall not be smaller than the drain connection on the appliance. Such piping shall maintain a minimum horizontal slope in the direction of discharge of not less than one eighth unit vertical in 12 units horizontal (1-percent slope).

Add new text as follows:

307.1.2 Identification. Where condensate piping is concealed, primary and secondary drain pipes that serve the same appliance and terminate together at a remote location shall be identified.

307.2.3.3 Identification. Where condensate piping is concealed, primary and secondary drain pipes that serve the same appliance and terminate together at a remote location shall be identified.

Reason:

Condensate drain systems from the same appliance need to be identified when terminating together at a remote location when the piping is concealed or partially concealed and could have possibly changed orientation. Occupants and service personnel won't be able to tell by looking at the piping which system is discharging and can't identify if they have a problem

Cost Impact

The code change proposal will not increase or decrease the cost of construction .

Simply marking the lines in a way that the code official approves should not increase the cost.

Internal ID: 121

M11-18

IMC: 307.2.1.1 (IPC [M] 314.2.1.1) (New)

Proponent: Pennie Feehan, representing Plumbing, Mechanical, and Fuel Gas Code Action Committee (PMGCAC@iccsafe.org)

2018 International Mechanical Code

Add new text as follows:

307.2.1.1 (IPC [M] 314.2.1.1) Condensate discharge. Condensate drains shall not directly connect to any plumbing drain, waste or vent pipe. Condensate drains shall not discharge into a plumbing fixture other than a floor sink, floor drain, trench drain, mop sink, hub drain, standpipe, utility sink or laundry sink. Condensate drain connections to a lavatory wye branch tailpiece or to a bathtub overflow pipe, shall not be considered as discharging to a plumbing fixture. Except where discharging to grade outdoors, the point of discharge of condensate drains shall be located within the same occupancy, tenant space or dwelling unit as the source of the condensate.

Reason:

The codes are silent on draining condensate to fixture connections (lav tailpiece and tub overflow) even though such practice is common in some locations. It is also common to find holes drilled into plumbing vents and stacks for the purpose of directly connecting a condensate drain. This practice is prohibited by code by strong implication, extended logic, but is not stated in plain text. This proposal lists the appropriate fixtures for receiving condensate waste and prohibits discharge to inappropriate fixtures. Condensate from one tenant space or dwelling must not discharge at a point in another tenant space or dwelling for reasons of limited access and potential damage to property.

This proposal is submitted by the ICC Plumbing/Mechanical/Gas Code Action Committee (PMG CAC). The PMG CAC was established by the ICC Board of Directors to pursue opportunities to improve and enhance the International Codes or portions thereof that were under the purview of the PMG CAC. In 2017 the PMG CAC held one face-to-face meeting and 11 conference call meetings. Numerous interested parties attended the committee meetings and offered their input.

Cost Impact

The code change proposal will not increase or decrease the cost of construction .

This proposal will not increase the cost of construction because no additional labor, materials, equipment, appliances or devices are mandated beyond what is currently required by the code.

Internal ID: 560

M12-18

IMC: SECTION 313 (New), 313.1 (New), ordinal

Proponent: Connor Barbaree, ASHRAE, representing ASHRAE (cbarbaree@ashrae.org)

2018 International Mechanical Code

Add new text as follows:

SECTION 313 SYSTEM DESIGN CONSIDERATIONS

313.1 Design of Building Water Systems. The design of building water systems shall be in accordance with ASHRAE 188.

ASHRAE

ASHRAE
1791 Tullie Circle NE
Atlanta GA 30329

188-2018:

Legionellosis: Risk Management for Building Water Systems

Reason:

ASHRAE Standard 188 was developed with the intent of providing code officials and building operators' information on how to manage the risk of legionellosis. ASHRAE Standard 188 was published on June 26, 2015, and is now publicly available as a final, published ANSI Standard. ASHRAE Standard 188 (2018) has been in continuous maintenance, and several addenda have been approved and published, as well as improvements in code compatible language which will be incorporated into the published 2018 standard. There are many design considerations in the ASHRAE standard that will help minimize Legionella bacteria growth in building water systems which can lead to Legionnaires Disease when water droplets are aerosolized and breathed in. Following the ASHRAE Standard will minimize the risk of a person contracting Legionnaires' disease or Legionellosis by having the design team consider system maintenance procedures to control the risk of legionellosis associated with plumbing & mechanical systems.

For more information on the standard, go here: <http://www.techstreet.com/ashrae/products/1897561>.

Bibliography:

Bibliography: See the following websites for more information:

www.LegionellaPrevention.org.

<http://www.cdc.gov/legionella/about/>

www.Legionella.com

www.hcinfo.com

http://www.who.int/water_sanitation_health/emerging/legionella.pdf

Cost Impact

The code change proposal will increase the cost of construction .

Buildings without a history of Legionella and not fitting the requirements will not need to add to the cost of construction. A water management plan will need to be done if a building meets certain minimum requirements. The cost of construction to address temperature, stagnation and water treatment will slightly increase the cost of construction and maintenance. Any building that is operating without growing Legionella should already has these processes in place, this will simply require documentation as part of a water management plan. This will provide for system design, operation and treatment that will minimize legionella bacteria growth and help prevent Legionnaires Disease.

Analysis: A review of the standard proposed for inclusion in the code, with regard to the ICC criteria for referenced standards (Section 3.6 of CP#28) will be posted on the ICC website on or before April 2, 2018.

Internal ID: 357

M13-18

IMC: 202 (New), 403.3.1, 403.3.2, 403.3.2.1

Proponent: Mike Moore, representing The Home Ventilating Institute (mmoore@newportventures.net)

2018 International Mechanical Code

Add new definition as follows:

BALANCED VENTILATION SYSTEM. A ventilation system where the total outdoor air supply air flow and total exhaust air flow are simultaneously within 10% of their average.

Revise as follows:

403.3.1 Other buildings intended to be occupied. The design of local exhaust systems and ventilation systems for outdoor air for occupancies other than Group R-2, R-3 and R-4 ~~three stories and less above grade plane~~ shall comply with Sections 403.3.1.1 through 403.3.1.5.

403.3.2 Group R-2, R-3 and R-4 occupancies, ~~three stories and less~~ occupancies. The design of local exhaust systems and ventilation systems for outdoor air in Group R-2, R-3 and R-4 occupancies ~~three stories and less in height above grade plane~~ shall comply with Sections 403.3.2.1 through 403.3.2.5.

403.3.2.1 Outdoor air for dwelling units. ~~An outdoor air~~ A balanced ventilation system ~~consisting of a mechanical exhaust system, supply system or combination thereof~~ shall be installed to provide outdoor air for each dwelling unit. ~~Local exhaust or supply systems, including outdoor air ducts connected to the return side of an air handler, are permitted to serve as such a system.~~ The balanced ventilation system shall be designed to provide the required rate of outdoor air continuously during the period that the building is occupied. The minimum continuous outdoor airflow rate shall be determined in accordance with Equation 4-9.

$$Q_{OA} = 0.01A_{\text{floor}} + 7.5(N_{br} + 1)$$

(Equation 4-9)

where:

Q_{OA} = outdoor airflow rate, cfm

A_{floor} = floor area, ft²

N_{br} = number of bedrooms; not to be less than one

Exception: The outdoor air ventilation system is not required to operate continuously where the system has controls that enable operation for not less than 1 hour of each 4-hour period. The average outdoor air flow rate over the 4-hour period shall be not less than that prescribed by Equation 4-9.

Reason:

Chapter 4 requires outdoor air to be provided by an outdoor air ventilation system. For dwelling units other than those in low-rise buildings of R-2, R-3, and R-4 occupancies, this ventilation system is required to be balanced (Section 403.3.1.5). Outdoor air is defined as "Ambient air that enters a building through a ventilation system, through intentional openings for natural ventilation, or by infiltration." Unless a ventilation system is balanced, it will introduce transfer air from neighboring units, which can negate much of the benefit of ventilation. This proposal will align the requirements for low-rise mechanical ventilation units with existing requirements for mid- and high-rise ventilation units (i.e., dwelling units in buildings of all R2, R3, and R4 occupancies would need balanced ventilation systems to provide outdoor air). Further, it will permit lower ventilation rates for mid- and high-rise dwelling units than currently allowed, thereby saving significant energy.

Precedents and rationale for this proposal include:

Exhaust dwelling unit ventilation systems are not permitted for mid-rise or high-rise dwelling units in the IMC (Section 403.3.5.1 requires that systems be balanced), were not permitted for mid- or high-rise dwelling units that were in compliance with ASHRAE 62.1, and should not be permitted low-rise buildings of R-2, R-3, and R-4 occupancies either. Such systems establish pressure imbalances across dwelling units, and the majority of the makeup air introduced by such systems is not outdoor air, but is transfer air from adjacent units or corridors.

Exhaust dwelling unit ventilation with dedicated passive vent air inlets should also not be permitted in any attached dwelling unit, because research has shown that these systems consistently fail to provide the targeted outdoor air flow rates. Industry experience with dedicated makeup air inlets and a recent study conducted by the Northwest Energy Efficiency Alliance,[1] have demonstrated that occupants generally keep inlets closed. The same study concluded that, "the analysis of inlet vents failed to show clear benefits from their usage." A separate study

sponsored by the U.S. Department of Energy also found dedicated passive air inlets to be ineffective: “airflow from the passive vents was 13%–36% of the exhaust ventilation rate.... most of the makeup air comes from unintentional sources—from leaks in the exterior envelope, neighboring apartments, or the corridor.”[2] Further, this study demonstrated that verifying the targeted outdoor air flow rate at dedicated outdoor air inlets was not possible in the dwelling units tested.

Supply-only outdoor air systems with or without dedicated makeup air outlets solve some of the problems with exhaust systems (e.g., providing a known source of filtered outdoor air), but they too induce pressure differentials that can lead to transfer of odors and pollutants across dwelling units and between dwelling units and corridors/common areas, diminishing the benefit of providing filtered outdoor air.

Unlike exhaust-only systems, exhaust with dedicated passive vent outdoor air inlets, and supply-only systems, **balanced mechanical ventilation systems** do not induce pressure differentials across attached dwelling units and do not introduce transfer air with outdoor air. The IMC already requires that high-rise dwelling unit “ventilation systems shall be balanced by an approved method” (2015 IMC Section 403.3.1.5). Reducing pressure differentials not only reduces the transfer of odor and pollutants between dwelling units and corridors/common areas, but it also limits the migration of moisture through building assemblies via air leakage, which can lead to condensation, mold, and durability problems. Additionally, balanced systems are able to provide filtered air directly from the outdoors and to temper the outdoor air (if provided with a heat or energy recovery core), increasing the likelihood of system operation by occupants.

Bibliography:

[1] Eklund, K., Kunkle, R., Banks, A., and Hales, D. 2015. Pacific Northwest Residential Ventilation Effectiveness Study. WSUEEP14-020.

[2] Maxwell, S., Berger, D., and Zuluaga, M. 2016. Evaluation of Passive Vents in New Construction Multifamily Buildings. (Subcontractor Report, NREL/SR-5500-64758). Golden, CO: National Renewable Energy Laboratory.

Cost Impact

The code change proposal will increase the cost of construction .

This proposal will increase the costs of engineering and construction where similar requirements do not already exist. For example, the IMC already requires that ventilation air be balanced for mid- and high-rise dwelling units. The requirement for balanced ventilation can be achieved by coupling an in-line supply fan with an exhaust fan that has a similar exhaust rate. Where balanced ventilation is not already required by the IMC, exhaust fans are required. Assuming that the exhaust fan is already installed, the incremental cost is associated with the supply fan, supply fan ducting, and the control/wiring to run both the supply and exhaust fan off a single switch. An in-line supply fan costs around \$120 retail. Ducting for the in-line supply fan can be estimated at ~\$19 per linear foot, or ~\$100 for a short, 5' run from the exterior. In-line supply fans are frequently specified to provide outdoor air in multifamily projects - especially in warm and mild climates. Where this is the case, the only incremental costs associated with this proposal would be for the wiring and switch to control the supply and exhaust fan simultaneously. Any incremental costs incurred are expected to decrease as balanced systems become more common; furthermore, the incremental costs are offset by the expected improvement in air quality and its associated health benefits.

Internal ID: 2371

M14-18

IMC: 307.2.2 (IPC [M] 314.2.2)

Proponent: Michael Cudahy, representing Plastic Pipe and Fittings Association (mikec@cmservices.com)

2018 International Mechanical Code

Revise as follows:

307.2.2 Drain pipe materials and sizes. Components of the condensate disposal system shall be ABS, cast iron, ~~galvanized steel~~, copper, ~~and~~ copper alloy, CPVC, cross-linked polyethylene, ~~galvanized steel~~, PE-RT, polyethylene, ~~ABS polypropylene~~, CPVC, PVC, ~~or polypropylene~~ PVDF pipe or tubing. Components shall be selected for the pressure and temperature rating of the installation. Joints and connections shall be made in accordance with the applicable provisions of Chapter 7 of the International Plumbing Code relative to the material type. Condensate waste and drain line size shall be not less than $\frac{3}{4}$ -inch pipe size internal diameter and shall not decrease in size from the drain pan connection to the place of condensate disposal. Where the drain pipes from more than one unit are manifolded together for condensate drainage, the pipe or tubing shall be sized in accordance with Table 307.2.2.

Reason:

List should be alphabetized. PERT and PVDF pipes and tubes already in the code could certainly be used in the application.

Cost Impact

The code change proposal will not increase or decrease the cost of construction .

Adding other options for materials will not alter cost.

Internal ID: 950

M15-18 Part I

IMC: 401.2

Proponent: Mike Moore, representing The Home Ventilating Institute (mmoore@newportventures.net)

THIS IS A 2 PART CODE CHANGE. BOTH PARTS WILL BE HEARD BY THE IMC COMMITTEE. PLEASE SEE THE HEARING ORDER FOR THE IMC COMMITTEE.

2018 International Mechanical Code

Revise as follows:

401.2 Ventilation required. Every occupied space shall be ventilated by natural means in accordance with Section 402 or by mechanical means in accordance with Section 403. ~~Where the air infiltration rate in a dwelling unit is less than 5 air changes per hour when tested with a blower door at a pressure of 0.2 inch water column (50 Pa) in accordance with Section R402.4.1.2 of the International Energy Conservation Code, the dwelling unit~~ Group-R dwelling units served by space-heating or cooling equipment shall be ventilated by mechanical means in accordance with Section 403. Ambulatory care facilities and Group I-2 occupancies shall be ventilated by mechanical means in accordance with Section 407.

Internal ID: 596

M15-18 Part II

IBC: 1202.1

Proponent: Mike Moore, representing The Home Ventilating Institute (mmoore@newportventures.net)

2018 International Building Code

1202.1 General. Buildings shall be provided with natural ventilation in accordance with Section 1202.5, or mechanical ventilation in accordance with the International Mechanical Code. ~~Where the air infiltration rate in a dwelling unit is less than 5 air changes per hour where tested with a blower door at a pressure 0.2 inch w.c. (50 Pa) in accordance with Section R402.4.1.2 of the International Energy Conservation Code—Residential Provisions, the dwelling unit~~ . Group R dwelling units served by the space-heating or cooling equipment shall be ventilated by mechanical means in accordance with Section 403 of the International Mechanical Code. Ambulatory care facilities and Group I-2 occupancies shall be ventilated by mechanical means in accordance with Section 407 of the International Mechanical Code.

Reason:

Building tight dwelling units has benefits of energy efficiency; improved comfort; and improved odor, rodent, and sound control. Tight buildings are typically the byproduct of better fire and smoke control as well. Beginning with the 2012 IECC, building tight has been code minimum practice, which is good. However, we learned in the 1970s that building tight without mechanically ventilating results in sick building syndrome.

So, since 2012, the code has required that when dwelling units are tested and verified to be tight, they also be provided with mechanical ventilation. The problem is that we've heard from ICC staff, code officials, builders, and design professionals that it's hard to follow the code language requirements. Currently, we have a 6-step process to identify that mechanical ventilation is required for all low-rise, Group-R IMC dwelling units. For mid- and high-rise dwelling units that are built to the IECC commercial chapter, it's not clear whether mechanical ventilation is required since they have a different testing metric than is referenced in Section 401.2 of the IMC. This introduces needless confusion. Here's what the process looks like:

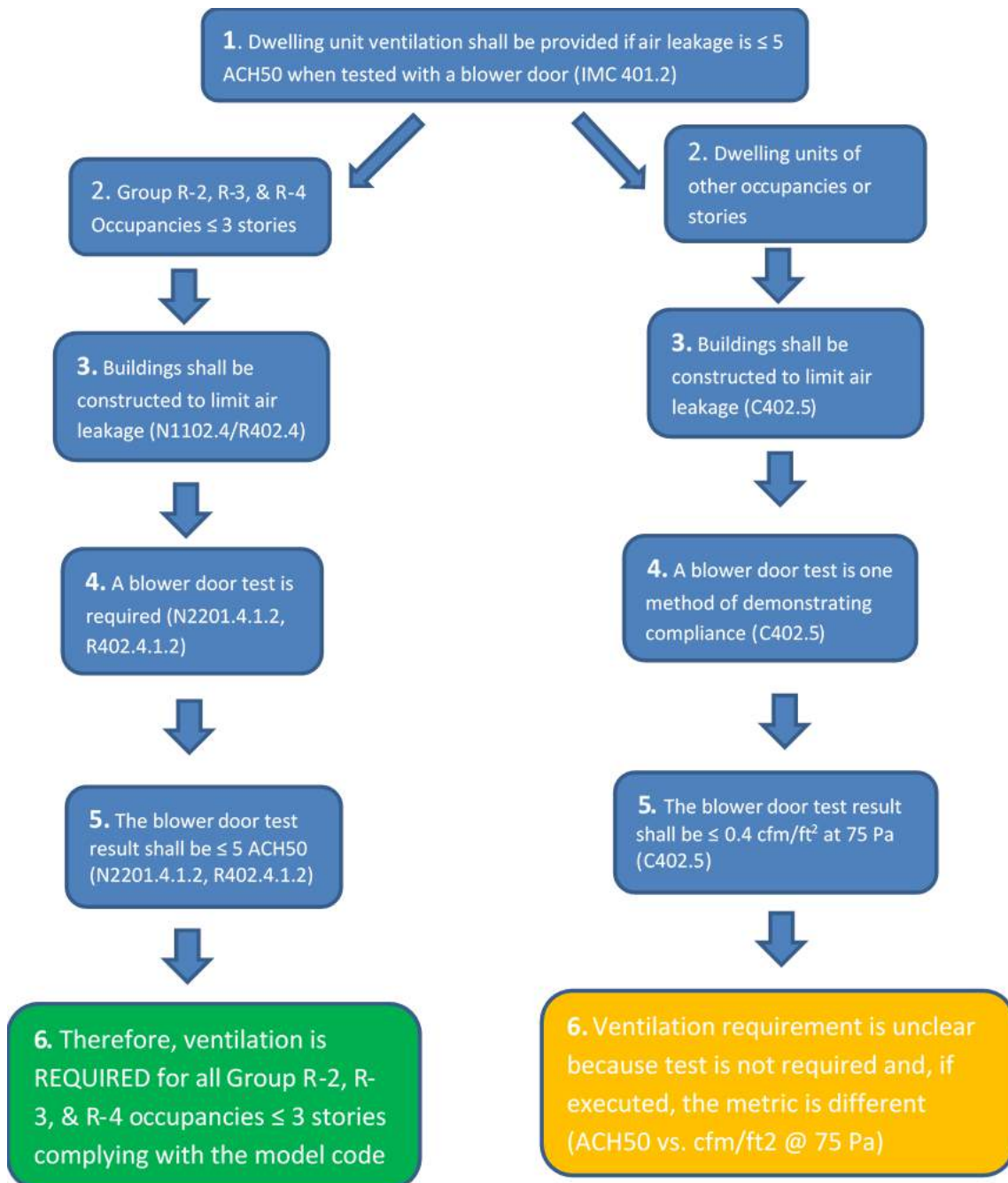

Instead of a 6-step process, we can simplify the code and enforcement by jumping straight to the conclusion for low-rise, Group R-2, R-3, and R-4 occupancies: mechanical ventilation is required for all dwelling units. This proposal does exactly that. Additionally, this proposal recognizes that the target maximum leakage rate for high-rise dwelling units (0.4 cfm/ft² @ 75 Pa) is comparable to that of low-rise dwelling units (5 ACH50), and the effective leakage to outdoors for all attached dwelling units is far below that of single family detached homes that are already required by the IRC to provide mechanical ventilation. Additionally, U.S. Census data show that occupancy per square foot of floor area in multifamily dwelling units is almost twice that of single family dwelling units, demonstrating a greater need for mechanical ventilation in multifamily dwelling units. For these reasons, the I-code requirement for mechanical ventilation of dwelling units should be extended beyond the current requirement for only low-rise dwelling units to include mid- and high-rise dwelling units.

Finally, this proposal introduces an exception for the mechanical ventilation requirement in climates and situations where natural ventilation is expected to provide all of the climate control and ventilation needed (i.e., when no space-heating or cooling equipment is provided). A similar exception exists in ASHRAE 62.2.

Cost Impact

The code change proposal will increase the cost of construction .

Ventilation is already required for IMC Group R-2, R-3, and R-4 dwelling units, so this proposal will not increase the cost of construction for these dwelling units. This proposal will increase the cost of construction for mid- and high-rise

dwelling units that are not currently provided with mechanical ventilation. However, this initial investment may be recouped by building owners based on greater tenant satisfaction and retention with respect to indoor air quality.

Internal ID: 3484

M16-18

IMC: 401.4, 501.3.1

Proponent: Mike Moore, representing The Home Ventilating Institute (mmoore@newportventures.net)

2018 International Mechanical Code

Revise as follows:

401.4 Intake opening location. Air intake openings shall comply with all of the following:

1. Intake openings shall be located not less than 10 feet (3048 mm) from lot lines or buildings on the same lot.
2. Mechanical and gravity outdoor air intake openings shall be located not less than 10 feet (3048 mm) horizontally from any hazardous or noxious contaminant source, such as vents, streets, alleys, parking lots and loading docks, except as specified in Item 3 or Section 501.3.1. Outdoor air intake openings shall be permitted to be located less than 10 feet (3048 mm) horizontally from streets, alleys, parking lots and loading docks provided that the openings are located not less than 25 feet (7620 mm) vertically above such locations. Where openings front on a street or public way, the distance shall be measured from the closest edge of the street or public way.
3. Intake openings shall be located not less than 3 feet (914 mm) below contaminant sources where such sources are located within 10 feet (3048 mm) of the opening. Separation is not required between intake air openings and living space exhaust air openings of an individual dwelling unit or sleeping unit where a factory-built intake/exhaust combination termination fitting is used to separate the air streams in accordance with the manufacturer's instructions.
4. Intake openings on structures in flood hazard areas shall be at or above the elevation required by Section 1612 of the International Building Code for utilities and attendant equipment.

501.3.1 Location of exhaust outlets. The termination point of exhaust outlets and ducts discharging to the outdoors shall be located with the following minimum distances:

1. For ducts conveying explosive or flammable vapors, fumes or dusts: 30 feet (9144 mm) from property lines; 10 feet (3048 mm) from operable openings into buildings; 6 feet (1829 mm) from exterior walls and roofs; 30 feet (9144 mm) from combustible walls and operable openings into buildings that are in the direction of the exhaust discharge; 10 feet (3048 mm) above adjoining grade.
2. For other product-conveying outlets: 10 feet (3048 mm) from the property lines; 3 feet (914 mm) from exterior walls and roofs; 10 feet (3048 mm) from operable openings into buildings; 10 feet (3048 mm) above adjoining grade.
3. For all *environmental air* exhaust: 3 feet (914 mm) from property lines; 3 feet (914 mm) from operable openings into buildings for all occupancies other than Group U, and 10 feet (3048 mm) from mechanical air intakes. Such exhaust shall not be considered hazardous or noxious. Separation is not required between intake air openings and living space exhaust air openings of an individual dwelling unit or sleeping unit where a factory-built intake/exhaust combination termination fitting is used to separate the air streams in accordance with the manufacturer's instructions.
4. Exhaust outlets serving structures in flood hazard areas shall be installed at or above the elevation required by Section 1612 of the International Building Code for utilities and attendant equipment.
5. For specific systems, see the following sections:
 - 5.1. Clothes dryer exhaust, Section 504.4.
 - 5.2. Kitchen hoods and other kitchen exhaust *equipment*, Sections 506.3.13, 506.4 and 506.5.
 - 5.3. Dust, stock and refuse conveying systems, Section 511.2.
 - 5.4. Subslab soil exhaust systems, Section 512.4.
 - 5.5. Smoke control systems, Section 513.10.3.
 - 5.6. Refrigerant discharge, Section 1105.7.
 - 5.7. Machinery room discharge, Section 1105.6.1.

Reason:

This proposal is very similar to a PMGCAC proposal on the same subject. The only difference is that this proposal does not include the word "approved" in front of "factory-built intake/exhaust termination combination fitting". In some jurisdictions, equipment or products requiring approval will trigger an "alternative means and methods" process to secure a permit. As explained in the reason statement below, these products have been determined to perform well across manufacturers and models. With good performance and insignificant deviation across products, there is no need to further scrutinize these products or delay permits for dwelling units that specify them. This is the position of the Home Ventilating Institute.

The rest of the reason statement echoes that in the PMGCAC proposal:

Intake/exhaust combination terminations are regularly installed with heating and energy recovery ventilators (H/ERVs) used for dwelling units. Their use reduces building penetrations, labor, and associated system costs. By reducing the number of penetrations, air leakage can also be reduced, resulting in space conditioning energy savings. Further, the durability of the structure can be improved through reducing entry pathways for bulk water.

Manufacturer tests conducted by Natural Resources Canada (NRC) have demonstrated that use of intake/exhaust combination terminations results in minimum cross-contamination of airflows (i.e., not exceeding 4%; see NRC report A1-007793¹). These results are aligned with ASHRAE 62.2 approval of such devices which limits cross-contamination to 10%, as verified by the manufacturer. If approved, this proposed modification to the IRC would limit application of intake/exhaust combination terminations to "factory-built" units. Approval of this proposed modification is expected to result in more affordable and architecturally-flexible terminations.

Note: The IRC defines living space as, "space within a dwelling unit utilized for living, sleeping, eating, cooking, bathing, washing and sanitation purposes". The use of the term "environmental air" was also considered, but was abandoned because "environmental air" can also include exhaust air from parking garages and clothes dryers, which we want to exclude from this exception.

Bibliography:

1. Ouazia, B. 2016. Evaluation of a dual hood performance in term of contaminant re-entrainment from exhaust to supply. A1-007793. National Research Council Canada. For a copy of the report, please contact the proponent at the email address provided. Additional reports are available from the proponent upon request.

Cost Impact

The code change proposal will decrease the cost of construction .

This proposal can reduce the number of intake and exhaust penetrations required for a dwelling unit, thereby reducing the cost of construction.

Internal ID: 1915

M17-18

IMC: 401.4, 501.3.1

Proponent: Pennie Feehan, representing Plumbing, Mechanical, and Fuel Gas Code Action Committee (PMGCAC@iccsafe.org)

2018 International Mechanical Code

Revise as follows:

401.4 Intake opening location. Air intake openings shall comply with all of the following:

1. Intake openings shall be located not less than 10 feet (3048 mm) from lot lines or buildings on the same lot.
2. Mechanical and gravity outdoor air intake openings shall be located not less than 10 feet (3048 mm) horizontally from any hazardous or noxious contaminant source, such as vents, streets, alleys, parking lots and loading docks, except as specified in Item 3 or Section 501.3.1. Outdoor air intake openings shall be permitted to be located less than 10 feet (3048 mm) horizontally from streets, alleys, parking lots and loading docks provided that the openings are located not less than 25 feet (7620 mm) vertically above such locations. Where openings front on a street or public way, the distance shall be measured from the closest edge of the street or public way.
3. Intake openings shall be located not less than 3 feet (914 mm) below contaminant sources where such sources are located within 10 feet (3048 mm) of the opening. Separation is not required between intake air openings and living space exhaust air openings of an individual dwelling unit or sleeping unit where an approved factory-built intake/exhaust combination termination fitting is used to separate the air streams in accordance with the manufacturer's instructions.
4. Intake openings on structures in flood hazard areas shall be at or above the elevation required by Section 1612 of the International Building Code for utilities and attendant equipment.

501.3.1 Location of exhaust outlets. The termination point of exhaust outlets and ducts discharging to the outdoors shall be located with the following minimum distances:

1. For ducts conveying explosive or flammable vapors, fumes or dusts: 30 feet (9144 mm) from property lines; 10 feet (3048 mm) from operable openings into buildings; 6 feet (1829 mm) from exterior walls and roofs; 30 feet (9144 mm) from combustible walls and operable openings into buildings that are in the direction of the exhaust discharge; 10 feet (3048 mm) above adjoining grade.
2. For other product-conveying outlets: 10 feet (3048 mm) from the property lines; 3 feet (914 mm) from exterior walls and roofs; 10 feet (3048 mm) from operable openings into buildings; 10 feet (3048 mm) above adjoining grade.
3. For all *environmental air* exhaust: 3 feet (914 mm) from property lines; 3 feet (914 mm) from operable openings into buildings for all occupancies other than Group U, and 10 feet (3048 mm) from mechanical air intakes. Such exhaust shall not be considered hazardous or noxious. Separation is not required between intake air openings and living space exhaust air openings of an individual dwelling unit or sleeping unit where an approved factory-built intake/exhaust combination termination fitting is used to separate the air streams in accordance with the manufacturer's instructions.
4. Exhaust outlets serving structures in flood hazard areas shall be installed at or above the elevation required by Section 1612 of the International Building Code for utilities and attendant equipment.
5. For specific systems, see the following sections:
 - 5.1. Clothes dryer exhaust, Section 504.4.
 - 5.2. Kitchen hoods and other kitchen exhaust *equipment*, Sections 506.3.13, 506.4 and 506.5.
 - 5.3. Dust, stock and refuse conveying systems, Section 511.2.
 - 5.4. Subslab soil exhaust systems, Section 512.4.
 - 5.5. Smoke control systems, Section 513.10.3.
 - 5.6. Refrigerant discharge, Section 1105.7.
 - 5.7. Machinery room discharge, Section 1105.6.1.

Reason:

Intake/exhaust combination terminations are regularly installed with heating and energy recovery ventilators (H/ERVs) used for dwelling units. Their use reduces building penetrations, labor, and associated system costs. By reducing the number of penetrations, air leakage can also be reduced, resulting in space conditioning energy savings. Further, the durability of the structure can be improved through reducing entry pathways for bulk water.

Manufacturer tests conducted Natural Resources Canada (NRC) have demonstrated that use of intake/exhaust combination terminations results in minimum cross-contamination of airflows (i.e., not exceeding 4%; see NRC report A1-007793¹). These results are aligned with ASHRAE 62.2 approval of such devices which limits cross-contamination to 10%, as verified by the manufacturer. If approved, this proposed modification is expected to result in more affordable and architecturally flexible terminations.

Note: The IRC defines living space as, “space within a dwelling unit utilized for living, sleeping, eating, cooking, bathing, washing and sanitation purposes”.

This proposal is submitted by the ICC Plumbing/Mechanical/Gas Code Action Committee (PMG CAC). The PMG CAC was established by the ICC Board of Directors to pursue opportunities to improve and enhance the International Codes or portions thereof that were under the purview of the PMG CAC. In 2017 the PMG CAC held one face-to-face meeting and 11 conference call meetings. Numerous interested parties attended the committee meetings and offered their input.

Bibliography:

Ouazia, B. 2016. Evaluation of a dual hood performance in term of contaminant re-entrainment from exhaust to supply. A1-007793. National Research Council Canada. For a copy of the report, please contact the proponent at the email address provided. Additional reports are available from the proponent upon request.

Cost Impact

The code change proposal will not increase or decrease the cost of construction .

This proposal will not increase the cost of construction because no additional labor, materials, equipment, appliances or devices are mandated beyond what is currently required by the code.

Internal ID: 573

M18-18

IMC: 403, 403.2.1, ordinal

Proponent: David Bixby, Air Conditioning Contractors of America (ACCA), representing Air Conditioning Contractors of America (bixster1953@yahoo.com)

2018 International Mechanical Code

Revise as follows:

SECTION 403 MECHANICAL VENTILATION

403.2.1 Recirculation of air. The outdoor air required by Section 403.3 shall not be recirculated. Air in excess of that required by Section 403.3 shall not be prohibited from being recirculated as a component of supply air to building spaces, except that:

1. Ventilation air shall not be recirculated from one *dwelling* to another or to dissimilar occupancies.
2. Supply air to a swimming pool and associated deck areas shall not be recirculated unless such air is dehumidified to maintain the relative humidity of the area at 60 percent or less. Air from this area shall not be recirculated to other spaces where more than 10 percent of the resulting supply airstream consists of air recirculated from these spaces. The design and installation of dehumidification systems shall comply with ACCA Manual SPS, HVAC Design for Swimming Pools and Spas.
3. Where mechanical exhaust is required by Note b in Table 403.3.1.1, recirculation of air from such spaces shall be prohibited. Recirculation of air that is contained completely within such spaces shall not be prohibited. Where recirculation of air is prohibited, all air supplied to such spaces shall be exhausted, including any air in excess of that required by Table 403.3.1.1.
4. Where mechanical exhaust is required by Note g in Table 403.3.1.1, mechanical exhaust is required and recirculation from such spaces is prohibited where more than 10 percent of the resulting supply air-stream consists of air recirculated from these spaces. Recirculation of air that is contained completely within such spaces shall not be prohibited.

Add new standard(s) follows:

ACCA

Air Conditioning Contractors of
America
2800 Shirlington Road, Suite 300
Arlington VA 22206

ANSI/ACCA 10 Manual SPS - 2010 RA 2017:

HVAC Design for Swimming Pools and Spas

Reason:

ACCA Manual SPS, HVAC Design for Swimming Pools and Spas, is a manual specifically focused on the design of HVAC systems for indoor pools and spas. Manual SPS is an ANSI-recognized standard that was developed with input from original equipment manufacturers (OEM), mechanical contractors, and consulting engineers. Manual SPS addresses the unique dynamics for pools and spas including controlling dew point temperatures of space air as well as space temperature, sealing and insulating duct work, and dehumidification systems and indoor air quality.

ACCA Manual SPS is proposed to be added to Chapter 15 Referenced Standards to support a proposed change to 403.2.1 adding SPS as a requirement for dehumidification design for swimming pools.

Cost Impact

The code change proposal will not increase or decrease the cost of construction .

Cost impacts for using Manual SPS will depend on the extra time involved in designing and coordinating an HVAC system for a swimming pool or spa project. System designers and installers must first scrutinize a project's plans and coordinate directly with the architect or builder to identify potential condensation, moisture control and air quality problems. These potential issues must be resolved between all parties before proceeding with the mechanical design. Once this has been addressed, the designer/installer will follow Manual SPS to install systems and OEM equipment used for controlling dew point temperature and dry-bulb temperature in an enclosed pool-spa space. .

M19-18

IMC: 404.1

Proponent: Randall Dahmen, Self, representing Self

2018 International Mechanical Code

Revise as follows:

404.1 Enclosed parking garages. Mechanical ventilation systems for enclosed parking garages shall operate continuously or shall be automatically operated by means of carbon monoxide detectors applied in conjunction with nitrogen dioxide detectors. Such detectors shall be listed in accordance with UL 2075 and installed in accordance with their listing and the manufacturers' instructions. Carbon monoxide detectors shall operate the system automatically at a level of 35 parts per million (ppm) and higher. Nitrogen dioxide detectors shall operate the system automatically at a level of 1 part per million (ppm) and higher. Automatic operation shall cycle the ventilation system between the following two modes of operation:

- 1.Full-on at an airflow rate of not less than 0.75 cfm per square foot [$0.0038 \text{ m}^3/(\text{s} \cdot \text{m}^2)$] of the floor area served.
- 2.Standby at an airflow rate of not less than 0.05 cfm per square foot [$0.00025 \text{ m}^3/(\text{s} \cdot \text{m}^2)$] of the floor area served.

Reason:

Carbon monoxide and nitrogen dioxide detectors are manufactured with a wide variety of detection capability. The current language is vague and provides no direction as to the threshold at which the detectors are to require operation of enclosed parking garage ventilation systems..

The Occupational Safety and Health Administration (OSHA) permissible exposure limit for carbon monoxide is 50 ppm of air, or 55 milligrams per cubic meter (mg/m^3) as an eight-hour time-weighted average concentration. The National Institute for Occupational Safety and Health (NIOSH) recommends exposure levels (REL) below the OSHA air-quality numbers. They recommend keeping exposure to less than 35ppm, or $40 \text{ mg}/\text{m}^3$ in eight hours.

Cost Impact

The code change proposal will not increase or decrease the cost of construction .

The code already requires the installation of carbon monoxide, as well as nitrogen dioxide, detectors. The proposed change only involves addressing the threshold at which they operate.

Internal ID: 1667

M20-18

IMC: 401.2, 403.1

Proponent: Shaunna Mozingo, representing City of Cherry Hills Village, Colorado Code Consulting (smozingo@coloradocode.net)

2018 International Mechanical Code

Revise as follows:

401.2 Ventilation required. Every occupied space shall be ventilated by natural means in accordance with Section 402 or by mechanical means in accordance with Section 403. ~~Where the air infiltration rate in a dwelling unit is less than 5 air changes per hour when tested with a blower door at a pressure of 0.2-inch water column (50 Pa) in accordance with Section R402.4.1.2 of the International Energy Conservation Code, the dwelling unit shall be ventilated by Dwelling units complying with the air leakage requirements of the International Energy Conservation Code or ASHRAE 90.1 shall be ventilated by~~ mechanical means in accordance with Section 403. Ambulatory care facilities and Group I-2 occupancies shall be ventilated by mechanical means in accordance with Section 407.

403.1 Ventilation system. Mechanical ventilation shall be provided by a method of supply air and return or *exhaust air* except that mechanical ventilation air requirements for Group R-2, R-3 and R-4 occupancies ~~three stories and less in height above grade plane~~ shall be provided by an exhaust system, supply system or combination thereof. The amount of supply air shall be approximately equal to the amount of return and *exhaust air*. The system shall not be prohibited from producing negative or positive pressure. The system to convey *ventilation air* shall be designed and installed in accordance with Chapter 6.

Reason:

After receiving many questions on the ventilation requirements for R-2 dwellings it has become clear that this section of the IMC is not easily understood, agreed with or being enforced as written. A stakeholder group was put together to tackle the issue and to see how we could change the ventilation requirements to be better understood. The group consisted of members from CAPMO, PNNL, Commissioning Agents, Mechanical Engineers, Code Officials, energy raters and energy advocates.

The mantra of the meeting was: "We either agree that it isn't required or agree that it is - then we change it."

Here were the discussed issues that we saw:

1: The lack of understanding of R-2's over 3 stories or 3 stories and less. (IECC definitions of residential and commercial buildings). Most people aren't looking at these definitions in the IECC so they all assume that since an "R-2" is built out of the IBC it is considered a commercial building in the IECC. When they get to the IMC and it starts talking about 3 stories or less and over 3 stories they don't understand why the buildings are treated differently for ventilation or any other requirement. While, from a building science perspective it can make sense why these buildings are separated this way, a lot of education time is spent on this very issue.

RESIDENTIAL BUILDING. For this code, includes detached one- and two-family dwellings and multiple single-family dwellings (townhouses) as well as Group R-2, R-3 and R-4 buildings three stories or less in height above grade plane.

COMMERCIAL BUILDING. For this code, all buildings that are not included in the definition of "Residential building."

2: IMC wording that is confusing, especially for people who also read the IRC Mechanical and the IECC because they aren't worded the same and it makes it hard to know what the requirements are. Some confusion came in by code officials who were requiring mechanical ventilation for all R-2s, commercial or residential, because they felt that the section below was stating that all envelopes had to be as tight as 3ach/50 even if they weren't tested. We had to go to ICC for an interpretation of the issues because 50% of the people believed mechanical ventilation was required for any R-2 and 50% believed it was only required for R-2s 3 stories or less.

401.2 Ventilation required.

Every occupied space shall be ventilated by natural means in accordance with Section 402 or by mechanical means in accordance with Section 403. Where the air infiltration rate in a dwelling unit is less than 5 air changes per hour when tested with a blower door at a pressure of 0.2-inch water column (50 Pa) in accordance with Section R402.4.1.2 of the International Energy Conservation Code, the dwelling unit shall be ventilated by mechanical means in accordance with Section 403. Ambulatory care facilities and I-2 occupancies shall be ventilated by mechanical means in accordance with

Section 407.

403.1 Ventilation system.

Mechanical ventilation shall be provided by a method of supply air and return or exhaust air except that mechanical ventilation air requirements for Group R-2, R-3 and R-4 occupancies three stories and less in height above grade plane shall be provided by an exhaust system, supply system or combination thereof. The amount of supply air shall be approximately equal to the amount of return and exhaust air. The system shall not be prohibited from producing negative or positive pressure. The system to convey ventilation air shall be designed and installed in accordance with Chapter 6.

3: ICC's code opinion:

From: Jason Toves <jtoves@ICCSafe.ORG> **Sent:** Wednesday, April 12, 2017 1:07 PM **To:** Shaunna Mozingo **Cc:** Renee Testroet **Subject:** RE: Section 401.2 - 2015 IMC

Ms. Mozingo,

Following are the responses to your questions.

April 12, 2017

RE: 15 IMC 401.2

Q1: Are R-2 occupancies in commercial buildings, as defined in the 2015 IECC, required to have a blower door test performed per Section 401.2 of the 2015 IMC?

A1: No, Section 401.2 of the IMC does not require blower door testing of R-2 occupancies in commercial buildings. It requires mechanical ventilation when R-2 occupancies are tested in accordance with Section R402.4.1.2 of the International Energy Conservation Code and the air infiltration rate is less than 5 air changes per hour, without requiring such testing.

Q2: Are R-2 occupancies in commercial buildings, as defined in the 2015 IECC, required to be mechanically ventilated per Section 401.2 of the 2015 IMC?

A2: No, Section 401.2 requires either natural ventilation per Section 402 or mechanical ventilation per Section 403. Section 401.2 only requires mechanical ventilation when R-2 occupancies are tested in accordance with Section R402.4.1.2 of the International Energy Conservation Code and the air infiltration rate is less than 5 air changes per hour, without requiring mechanical ventilation for R-2 occupancies in commercial buildings.

It should be noted that Section R402.4.1.2 of the 2015 International Energy Conservation Code applies to "Residential Buildings" (as defined in the IECC) only.

So now you decide, should ventilation actually be required in R-2 occupancies over 3 stories the same as it should be in buildings of less than 3 stories? Why should it be different when both codes require a tight building envelope with continuous air barriers?

The overarching feeling from the group was: "Everyone is building tight. Hinging mechanical ventilation on a test is causing a problem. It should just be required for all R occupancies."

We played around with the wording and finally just decided that it was easiest to just say that if your envelope complies with an energy code you must provide mechanical ventilation. It was that simple so that is what we did.

Cost Impact

The code change proposal will increase the cost of construction .

This proposal will increase the cost of construction but depending on the method chosen to mechanically ventilate (balanced, exhaust only, supply only), the cost typically only includes the cost of a timer/timers for an exhaust fan that is already required in a bathroom so that it runs continuously or down to 25% of the time. There are definitely climates where an exhaust only or supply only system are not recommended but there are more and more options for an economical balanced system that doesn't rely on an ERV or HRV, even though those costs are coming down as well.

Internal ID: 1365

M21-18

IMC: TABLE 403.3.1.1, 502.20, 502.20.1 (New)

Proponent: Gary Sadler, SalonSafe, LLC + Upland Architects, Inc, representing SalonSafe, LLC; Adam Rebello, representing Salon Safe LLC (adamr@55upland.com)

2018 International Mechanical Code

Revise as follows:

**TABLE 403.3.1.1
MINIMUM VENTILATION RATES**

OCCUPANCY CLASSIFICATION	OCCUPANT DENSITY #/1000 FT² ^a	PEOPLE OUTDOOR AIRFLOW RATE IN BREATHING ZONE, R_p CFM/PERSON	AREA OUTDOOR AIRFLOW RATE IN BREATHING ZONE, R_a CFM/FT² ^a	EXHAUST AIRFLOW RATE CFM/FT² ^a
Correctional facilities				
Booking/waiting	50	7.5	0.06	—
Cells				
without plumbing fixtures	25	5	0.12	—
with plumbing fixtures ^g	25	5	0.12	1.0
Day room	30	5	0.06	—
Dining halls (see "Food and beverage service")	—	—	—	—
Guard stations	15	5	0.06	—
Dry cleaners, laundries				
Coin-operated dry cleaner	20	15	—	—
Coin-operated laundries	20	7.5	0.12	—
Commercial dry cleaner	30	30	—	—
Commercial laundry	10	25	—	—
Storage, pick up	30	7.5	0.12	—
Education				
Art classroom ^g	20	10	0.18	0.7
Auditoriums	150	5	0.06	—
Classrooms (ages 5-8)	25	10	0.12	—
Classrooms (age 9 plus)	35	10	0.12	—
Computer lab	25	10	0.12	—
Corridors (see "Public spaces")	—	—	—	—
Day care (through age 4)	25	10	0.18	—
Lecture classroom	65	7.5	0.06	—
Lecture hall (fixed seats)	150	7.5	0.06	—
Locker/dressing rooms ^g	—	—	—	0.25
Media center	25	10	0.12	—
Multiuse assembly	100	7.5	0.06	—
Music/theater/dance	35	10	0.06	—
Science laboratories ^g	25	10	0.18	1.0
Smoking lounges ^b	70	60	—	—
Sports locker rooms ^g	—	—	—	0.5
Wood/metal shops ^g	20	10	0.18	0.5
Food and beverage service				
Bars, cocktail lounges	100	7.5	0.18	—
Cafeteria, fast food	100	7.5	0.18	—
Dining rooms	70	7.5	0.18	—
Kitchens (cooking) ^b	20	7.5	0.12	0.7

Hotels, motels, resorts and dormitories				
Bathrooms/toilet—private ^g	—	—	—	25/50 ^f
Bedroom/living room	10	5	0.06	—
Conference/meeting	50	5	0.06	—
Dormitory sleeping areas	20	5	0.06	—
Gambling casinos	120	7.5	0.18	—
Lobbies/prefunction	30	7.5	0.06	—
Multipurpose assembly	120	5	0.06	—
Offices				
Conference rooms	50	5	0.06	—
Main entry lobbies	10	5	0.06	—
Office spaces	5	5	0.06	—
Reception areas	30	5	0.06	—
Telephone/data entry	60	5	0.06	—
Private dwellings, single and multiple				
Garages, common for multiple units ^b	—	—	—	0.75
Kitchens ^b	—	—	—	25/100 ^f
Living areas ^c	Based on number of bedrooms. First bedroom, 2; each additional bedroom, 1	0.35 ACH but not less than 15 cfm/person	—	—
Toilet rooms and bathrooms ^g	—	—	—	20/50 ^f
Public spaces				
Corridors	—	—	0.06	—
Courtrooms	70	5	0.06	—
Elevator car	—	—	—	1.0
Legislative chambers	50	5	0.06	—
Libraries	10	5	0.12	—
Museums (children's)	40	7.5	0.12	—
Museums/galleries	40	7.5	0.06	—
Places of religious worship	120	5	0.06	—
Shower room (per shower head) ^g	—	—	—	50/20 ^f
Smoking lounges ^b	70	60	—	—
Toilet rooms — public ^g	—	—	—	50/70 ^e
Retail stores, sales floors and showroom floors				
Dressing rooms	—	—	—	0.25
Mall common areas	40	7.5	0.06	—
Sales	15	7.5	0.12	—
Shipping and receiving	2	10	0.12	—
Smoking lounges ^b	70	60	—	—
Storage rooms	—	—	0.12	—
Warehouses (see "Storage")	—	10	0.06	—
Specialty shops				
Automotive motor-fuel dispensing	—	—	—	1.5

Barber	25	7.5	0.06	0.5
Beauty salons ^b	25	20	0.12	0.6
Nail salons ^{b, h, i}	25	20	0.12	0.6
Embalming room ^b	—	—	—	2.0
Pet shops (animal areas) ^b	10	7.5	0.18	0.9
Supermarkets	8	7.5	0.06	—
Sports and amusement				
Bowling alleys (seating areas)	40	10	0.12	—
Disco/dance floors	100	20	0.06	—
Game arcades	20	7.5	0.18	—
Gym, stadium, arena (play area)	7	20	0.18	—
Health club/aerobics room	40	20	0.06	—
Health club/weight room	10	20	0.06	—
Ice arenas without combustion engines	—	—	0.30	0.5
Spectator areas	150	7.5	0.06	—
Swimming pools (pool and deck area)	—	—	0.48	—
Storage				
Repair garages, enclosed parking garages ^{b,d}	—	—	—	0.75
Refrigerated warehouses/freezers	—	10	—	0.75
Warehouses	—	10	0.06	—
Theaters				
Auditoriums (see "Education")	—	—	—	—
Lobbies	150	5	0.06	—
Stages, studios	70	10	0.06	—
Ticket booths	60	5	0.06	—
Transportation				
Platforms	100	7.5	0.06	—
Transportation waiting	100	7.5	0.06	—
Workrooms				
Bank vaults/safe deposit	5	5	0.06	—
Computer (without printing)	4	5	0.06	—
Copy, printing rooms	4	5	0.06	0.5
Darkrooms	—	—	—	1.0
Meat processing ^c	10	15	—	—
Pharmacy (prep. area)	10	5	0.18	—
Photo studios	10	5	0.12	—

For SI: 1 cubic foot per minute = 0.0004719 m³/s, 1 ton = 908 kg, 1 cubic foot per minute per square foot = 0.00508 m³/(s • m²), °C = [(°F) -32]/1.8, 1 square foot = 0.0929 m².

- a. Based on *net occupiable floor area*.
- b. Mechanical exhaust required and the recirculation of air from such spaces is prohibited. Recirculation of air that is contained completely within such spaces shall not be prohibited (see Section 403.2.1, Item 3).
- c. Spaces unheated or maintained below 50°F are not covered by these requirements unless the occupancy is continuous.
- d. Ventilation systems in enclosed parking garages shall comply with Section ~~404.404~~.
- e. Rates are per water closet or urinal. The higher rate shall be provided where the exhaust system is designed to operate intermittently. The lower rate shall be permitted only where the exhaust system is designed to operate continuously while occupied.
- f. Rates are per room unless otherwise indicated. The higher rate shall be provided where the exhaust system is designed to operate intermittently. The lower rate shall be permitted only where the exhaust system is designed to operate continuously while occupied.
- g. Mechanical exhaust is required and recirculation from such spaces is prohibited except that recirculation shall be permitted where the resulting supply airstream consists of not more than 10 percent air recirculated from these spaces. Recirculation of air that is contained completely within such spaces shall not be prohibited (see Section 403.2.1, Items 2 and 4).
- h. For nail salons, each manicure and pedicure station shall be provided with a *source capture system* capable of exhausting not less than 50 cfm per ~~station~~ station as measured not more than 12 inches (305 mm) horizontally and vertically from the point of chemical application. Exhaust inlets shall be located in accordance with Section 502.20 ~~and 502.20.1~~. ~~Where one or more required source capture systems operate continuously during occupancy, the exhaust rate and outdoor airflow rate from such systems shall be permitted to be applied to the exhaust flow rate and outdoor airflow rate required by Table 403.3.1.1 for the nail salon.~~
- i. Where nail salon services or a nail salon occupancy is ancillary to the main occupancy classification and a source capture system is provided in accordance with Section 502.20 and 502.20.1, the minimum ventilation rates for the main occupancy classification shall be permitted according to Table 403.3.1.1.

502.20 Manicure and pedicure stations. Manicure and pedicure stations shall be provided with ~~an a source capture exhaust system~~ in accordance with Table 403.3.1.1, Note h. Manicure tables and pedicure stations ~~not provided with factory installed exhaust inlets~~ shall be provided with fixed in-place, immovable exhaust inlets located not more than 12 inches (305 mm) horizontally and vertically from the point of chemical application and shall not draw fumes or contaminants past the human face. The source capture exhaust system shall be prohibited from recirculating air and shall discharge exhaust in accordance with Section 501.3 and shall also comply with the provisions of Section 502.20.1.

Add new text as follows:

502.20.1 Makeup Air. Makeup air shall be supplied during the operation of source capture exhaust systems that are provided for manicure tables and pedicure stations . The amount of makeup air supplied to the building from all sources shall be approximately equal to the amount of exhaust air for all exhaust systems for the building. The makeup air shall not reduce the effectiveness of the exhaust system. Makeup air shall be provided by gravity or mechanical means or both. Mechanical makeup air systems shall be automatically controlled to start and operate simultaneously with the exhaust system. Makeup air intake opening locations shall comply with Section 401.4. and Makeup air temperature shall comply with Section 508.1.

**Reason:
INTRODUCTION**

"Many of us go to nail salons to relax and to be pampered. We don't think of these places as potentially hazardous work environments, yet for many manicurists, regular on-the-job exposure to toxic chemicals is a reality. Workers often experience headaches, dizziness, rashes and other acute symptoms. Some chemicals are known to cause cancer and reproductive, developmental, and respiratory harm" (a)

The intent of these suggested modifications is to (1) better clarify the requirements for a source capture exhaust

system at manicure and pedicure stations where ambiguity exists, and to (2) better ensure the effectiveness of the exhaust system in removing harmful fumes and contaminants at the source and providing a healthy, safe environment for nail salon workers and their clients.

1. PROPOSED MODIFICATION TO TABLE 403.3.1.1 note h.

REASON: The suggested modification to note h in Table 403.3.1.1 attempts to clarify the minimum distance from which the exhaust rate is to be measured and give the AHJ or design professional better criteria by which to test and confirm code compliance. Also the balancing of exhausted air with makeup air is required by the IMC, therefore, the outdoor airflow rate should be permitted to be applied to the outdoor airflow rate required by Table 403.3.1.1 for the same reasons the exhaust rate is currently permitted to be applied when the source capture system is running continuously during occupancy.

2. PROPOSED ADDITION of note j TO TABLE 403.3.1.1

REASON: The addition of note j attempts to address increasing instances where nail services are offered in places like a retail or business occupancy where those nail services are not the primary business or occupancy. In these circumstances, if a source capture system is installed in accordance with Section 502.20 and 502.20.1, additional equipment and higher operating costs to comply with the greater nail salon ventilation rates would be reduced.

3. PROPOSED MODIFICATION TO SECTION 502.20 Manicure and Pedicure Stations

REASON: Work practices are an important part of achieving successful control of fume exposures; in particular, positioning the exhaust inlet close to the source of chemical application.

It is easy to confuse a fan's ability to blow a jet of air with it's ability to draw air into an exhaust inlet. That's why an exhaust inlet must be close to the source of the contamination to be an effective source capture system. Frequent changes in the location and position of the exhaust inlet from the source of chemical application can diminish the exhaust system's ability to draw air into the exhaust inlet at the code-required minimum air flow rate.

Therefore, it is suggested that the code require the exhaust inlets to be fixed in-place and immovable (for both factory and field installations) to ensure the desired maximum source capture effectiveness without depending on user control or placement.

Although a 50CFM exhaust rate at 12 inches (horizontally and vertically) from the source of chemical application is effective in capturing fumes and other contaminants, it's important to recognize that even when this requirement is met, the possibility of fumes to be drawn past the face of the technician and consumer still exist. This suggested modification helps to eliminate this possibility.

It is important to clarify that source capture exhaust is to be discharged to the outdoors and not recirculated. This requirement is consistent with other exhaust systems regulated by the IMC. We suggest including a reference to existing Section 501.3 to better clarify this requirement.

4. PROPOSED NEW SUB-SECTION: 502.20.1 Makeup Air.

REASON: The suggested addition of a new sub-section intends to recognize and reinforce the requirement for balancing the exhausted air with makeup air and help provide guidance on intake opening locations and makeup air temperature by referencing existing Sections 401.4 and 508.1 respectively.

Bibliography:

a. California Healthy Nail Salon Collaborative - website "THE NEED FOR HEALTHY NAIL SALONS" - <https://cahealthynailsalons.org/healthy-salons/>

Cost Impact

The code change proposal will not increase or decrease the cost of construction .

These code change proposals will only remove ambiguity and provide better guidance for design professionals, the AHJ and end-users alike.

Internal ID: 340

M22-18

IMC: 401.3

Proponent: Randall Dahmen, Self, representing Self

2018 International Mechanical Code

Revise as follows:

401.3 When required. Ventilation shall be provided during the periods that the room or space is occupied.

For swimming pool and deck areas, ventilation shall be provided continuously.

Reason:

Swimming pool and deck areas are commonly known to be susceptible to the growth of mold. Current language only requires ventilation to be provided when a room or space is occupied. It is a known fact that swimming pool areas continue to create humidity, distribute chloramines, etc. even when there is no individual in the space. The State of Wisconsin requires that natatorium areas be ventilated continuously. When complaints are made concerning swimming pool areas, one of the first efforts in the investigation is to validate that the ventilation is fully functional and operating continuously. It has been found on multiple occasions that the lack of a functioning ventilation system is the typical cause of a swimming pool mold problem, as well as indoor air quality issue.

Cost Impact

The code change proposal will not increase or decrease the cost of construction .

The equipment required to operate the swimming pool ventilation equipment is already required by code.

Internal ID: 1566

M23-18

IMC: 403.3.1.2

Proponent: Anthony Floyd, City of Scottsdale, representing City of Scottsdale (afloyd@scottsdaleaz.gov)

2018 International Mechanical Code

Revise as follows:

403.3.1.2 Exhaust ventilation. Exhaust airflow rate shall be provided in accordance with the requirements of Table 403.3.1.1. Outdoor air introduced into a space by an exhaust system shall be considered as contributing to the outdoor airflow required by Table 403.3.1.1. Intermittently operated exhaust fans in toilet rooms, bathrooms and shower rooms shall be provided with a delay-shutoff timer, occupant sensor or humidity sensor control.

Reason:

This code change provides compliance options for intermittently operated exhaust fans when the facility is occupied (occupant or humidity sensor activation) and for a limited period of time after the user leaves the room (delay timer, occupant or humidity sensor deactivation). Delay timer, occupant and humidity sensor exhaust fan controls are a consistent and effective means of removing moisture and pollutants from toilet, bath and shower facilities in private dwellings and public spaces in accordance with IMC Table 403.3.1.1.

The humidity level in a restroom or shower facility can be a perfect breeding ground for mold, mildew and micro-organisms that can negatively impact occupant health. Excess moisture has tremendous potential for damaging a building. It cracks and peels paint, ruins gypsum wallboard, causes exterior paint failure, warps doors and rusts cabinets and fixtures. Without control, it can even cause deterioration of joists and framing. As it condenses on windows, walls, ceilings and cabinets, it attracts dirt. It encourages mildew on tile grout and generally provides an environment for increased bacterial growth.

According to the Home Ventilation Institute, an intermittently operated exhaust fan needs to run at least 20 minutes after each shower to sufficiently remove moisture from an average size bathroom. Exhaust systems reduce the risk of mildew and mold growth which is a sanitation and durability concern in dwellings and public spaces, regardless of climate. Delay timer, occupant and humidity sensor controlled exhaust fans are more effective than a manually operated fan or an operable window that is usually left closed during the winter and summer months of the year.

Automatic shut-off controls help to ensure exhaust fan operates when toilet, bath and shower facilities are in use and for a limited period of time after the user leaves the room. Automatic controls also save energy by ensuring fans don't unnecessarily run after removal of moisture and pollutants.

Bibliography:

ASHRAE 62.1-2016 Ventilation and Acceptable Indoor Air Quality

Home Ventilating Institute - <http://www.hvi.org/publications/HowMuchVent.cfm>

Cost Impact

The code change proposal will increase the cost of construction .

A basic dial delay timer switch costs \$15, a basic occupant sensor costs \$10 and a basic humidity sensor switch costs \$46. Timer, occupant and moisture controlled exhaust fans reduce the potential of making costly moisture damage repairs to correct problems that is easy to avoid with sufficient local exhaust.

Internal ID: 547

M24-18

IMC: TABLE 403.3.1.1

Proponent: Connor Barbaree, ASHRAE, representing ASHRAE (cbarbaree@ashrae.org)

2018 International Mechanical Code

Revise as follows:

**TABLE 403.3.1.1
MINIMUM VENTILATION RATES**

OCCUPANCY CLASSIFICATION	OCCUPANT DENSITY#/1000 FT² a	PEOPLE OUTDOOR AIRFLOW RATE IN BREATHING ZONE, R_p CFM/PERSON	AREA OUTDOOR AIRFLOW RATE IN BREATHING ZONE, R_a CFM/FT² a	EXHAUST AIRFLOW RATE CFM/FT² a
Correctional facilities				
Booking/waiting	50	7.5	0.06	—
Cells				
without plumbing fixtures	25	5	0.12	—
with plumbing fixtures ⁹	25	5	0.12	1.0
Day room	30	5	0.06	—
Dining halls(see “Food and beverage service”)	—	—	—	—
Guard stations	15	5	0.06	—
Dry cleaners, laundries				
Coin-operated dry cleaner	20	15	—	—
Commercial dry cleaner	30	30	—	—
Commercial laundry	10	25	—	—
Storage, pick up	30	7.5	0.12	—
Education				
Art classroom ⁹	20	10	0.18	0.7
Auditoriums	150	5	0.06	—
Classrooms (ages 5-8)	25	10	0.12	—
Classrooms (age 9 plus)	35	10	0.12	—
Computer lab	25	10	0.12	—
Corridors (see “Public spaces”)	—	—	—	—
Day care (through age 4)	25	10	0.18	—
Lecture classroom	65	7.5	0.06	—
Lecture hall (fixed seats)	150	7.5	0.06	—
Locker/dressing rooms ⁹	—	—	—	0.25
Media center	25	10	0.12	—
Multiuse assembly	100	7.5	0.06	—
Music/theater/dance	35	10	0.06	—
Science laboratories ⁹	25	10	0.18	1.0
Smoking lounges ^b	70	60	—	—
Sports locker rooms ⁹	—	—	—	0.5
Wood/metal shops ⁹	20	10	0.18	0.5
Food and beverage service				
Bars, cocktail lounges	100	7.5	0.18	—
Cafeteria, fast food	100	7.5	0.18	—
Dining rooms	70	7.5	0.18	—
b				
Hotels, motels, resorts and dormitories				

Bathrooms/toilet—private ^g	—	—	—	25/50 ^f
Bedroom/living room	10	5	0.06	—
Conference/meeting	50	5	0.06	—
Dormitory sleeping areas	20	5	0.06	—
Gambling casinos	120	7.5	0.18	—
Lobbies/prefunction	30	7.5	0.06	—
Multipurpose assembly	120	5	0.06	—
Offices				
Conference rooms	50	5	0.06	—
Main entry lobbies	10	5	0.06	—
Office spaces	5	5	0.06	—
Reception areas	30	5	0.06	—
Telephone/data entry	60	5	0.06	—
Private dwellings, single and multiple				
Garages, common for multiple units ^b	—	—	—	0.75
Kitchens ^b	—	—	—	25/100 ^f
Living areas ^c	Based on number of bedrooms. First bedroom, 2; each additional bedroom, 1	0.35 ACH but not less than 15 cfm/person	—	—
Toilet rooms and bathrooms ^g	—	—	—	20/50 ^f
Public spaces				
Corridors	—	—	0.06	—
Courtrooms	70	5	0.06	—
Elevator car	—	—	—	1.0
Legislative chambers	50	5	0.06	—
Libraries	10	5	0.12	—
Museums (children's)	40	7.5	0.12	—
Museums/galleries	40	7.5	0.06	—
Places of religious worship	120	5	0.06	—
Shower room (per shower head) ^g	—	—	—	50/20 ^f
Smoking lounges ^b	70	60	—	—
Toilet rooms — public ^g	—	—	—	50/70 ^e
Retail stores, sales floors and showroom floors				
Dressing rooms	—	—	—	0.25
Mall common areas	40	7.5	0.06	—
Sales	15	7.5	0.12	—
Smoking lounges ^b	70	60	—	—
Storage rooms	—	—	0.12	—
Specialty shops				
Automotive motor-fuel dispensing stations ^b	—	—	—	1.5
Barber	25	7.5	0.06	0.5

Beauty salons ^b	25	20	0.12	0.6
Nail salons ^{b, h}	25	20	0.12	0.6
Embalming room ^b	—	—	—	2.0
Pet shops (animal areas) ^b	10	7.5	0.18	0.9
Supermarkets	8	7.5	0.06	—
Sports and amusement				
Bowling alleys (seating areas)	40	10	0.12	—
Disco/dance floors	100	20	0.06	—
Game arcades	20	7.5	0.18	—
Health club/aerobics room	40	20	0.06	—
Health club/weight room	10	20	0.06	—
Ice arenas without combustion engines	—	—	0.30	0.5
Spectator areas	150	7.5	0.06	—
Swimming pools (pool and deck area)	—	—	0.48	—
Storage				
Repair garages, enclosed parking garages ^{b, d}	—	—	—	0.75
Warehouses	—	10	0.06	—
Theaters				
Auditoriums (see "Education")	—	—	—	—
Ticket booths	60	5	0.06	—
Transportation				
Platforms	100	7.5	0.06	—
Transportation waiting	100	7.5	0.06	—
Workrooms				
Bank vaults/safe deposit	5	5	0.06	—
Computer (without printing)	4	5	0.06	—
Copy, printing rooms	4	5	0.06	0.5
Darkrooms	—	—	—	1.0
Meat processing ^c	10	15	—	—
Pharmacy (prep. area)	10	5	0.18	—
Photo studios	10	5	0.12	—

For SI: 1 cubic foot per minute = 0.0004719 m³/s, 1 ton = 908 kg, 1 cubic foot per minute per square foot = 0.00508 m³/(s • m²), °C = [(°F) - 32]/1.8, 1 square foot = 0.0929 m².

- a. Based on *net occupiable floor area*.
- b. Mechanical exhaust required and the recirculation of air from such spaces is prohibited. Recirculation of air that is contained completely within such spaces shall not be prohibited (see Section 403.2.1, Item 3).
- c. Spaces unheated or maintained below 50°F are not covered by these requirements unless the occupancy is continuous.
- d. Ventilation systems in enclosed parking garages shall comply with Section 404.
- e. Rates are per water closet or urinal. The higher rate shall be provided where the exhaust system is designed to operate intermittently. The lower rate shall be permitted only where the exhaust system is designed to operate continuously while occupied.
- f. Rates are per room unless otherwise indicated. The higher rate shall be provided where the exhaust system is designed to operate intermittently. The lower rate shall be permitted only where the exhaust system is designed to operate continuously while occupied.
- g. Mechanical exhaust is required and recirculation from such spaces is ~~prohibited except that recirculation shall be permitted where the resulting supply airstream consists of not more than 10 percent air recirculated from these spaces.~~ prohibited. For occupancies other than science laboratories, where there is a wheel type energy recovery ventilation (ERV) unit in the exhaust system design, the volume of air leaked from the exhaust airstream into the outdoor airstream within the ERV shall be less than 10 percent of the outdoor air volume. Recirculation of air that is contained completely within such spaces shall not be prohibited (see Section 403.2.1, Items 2 and 4).
- h. For nail salons, each manicure and pedicure station shall be provided with a *source capture system* capable of exhausting not less than 50 cfm per station. Exhaust inlets shall be located in accordance with Section 502.20. Where one or more required source capture systems operate continuously during occupancy, the exhaust rate from such systems shall be permitted to be applied to the exhaust flow rate required by Table 403.3.1.1 for the nail salon.

Reason:

The proposed change makes the code intended language consistent with ASHRAE 62.1-2016.

As written the exception allows a larger percentage of recirculated exhaust air that may negatively affect IAQ.

A simple way to look at the current language is that the purpose of exhaust is to remove the air and its associated compounds from the building. Allowing 10% supply air to consist of exhausted air compromises the purpose of exhaust.

Bibliography:

ASHRAE 62.1 - 2016

Cost Impact

The code change proposal will not increase or decrease the cost of construction .

This proposal revises recirculation air requirements. However, this does not dictate system design to meet those requirements and therefore does not increase the cost of construction.

Internal ID: 1543

M25-18

IMC: TABLE 403.3.1.1

Proponent: Connor Barbaree, ASHRAE, representing ASHRAE (cbarbaree@ashrae.org)

2018 International Mechanical Code

Revise as follows:

**TABLE 403.3.1.1
MINIMUM VENTILATION RATES**

OCCUPANCY CLASSIFICATION	OCCUPANT DENSITY#/1000 FT² a	PEOPLE OUT DOOR AIRFLOW RATE IN BREATHING ZONE, R_p CFM/PERSON	AREA OUT DOOR AIRFLOW RATE IN BREATHING ZONE, R_a CFM/FT² a	EXHAUST AIRFLOW RATE CFM/FT² a
Correctional facilities				
Booking/waiting	50	7.5	0.06	—
Cells				
without plumbing fixtures	25	5	0.12	—
with plumbing fixtures ⁹	25	5	0.12	1.0
Day room	30	5	0.06	—
Dining halls(see “Food and beverage service”)	—	—	—	—
Guard stations	15	5	0.06	—
Dry cleaners, laundries				
Coin-operated dry cleaner	20	15	—	—
Coin-operated laundries	20	7.5	0.12	—
Commercial dry cleaner	30	30	—	—
Commercial laundry	10	25 5	— 0.12	—
Storage, pick up	30	7.5	0.12	—
Education				
Art classroom ⁹	20	10	0.18	0.7
Auditoriums	150	5	0.06	—
Classrooms (ages 5-8)	25	10	0.12	—
Classrooms (age 9 plus)	35	10	0.12	—
Computer lab	25	10	0.12	—
Corridors (see “Public spaces”)	—	—	—	—
Day care (through age 4)	25	10	0.18	—
Lecture classroom	65	7.5	0.06	—
Lecture hall (fixed seats)	150	7.5	0.06	—
Locker/dressing rooms ⁹	—	—	—	0.25
Media center	25	10	0.12	—
Multiuse assembly	100	7.5	0.06	—
Music/theater/dance	35	10	0.06	—
Science laboratories ⁹	25	10	0.18	1.0
Smoking lounges ^b	70	60	—	—
Sports locker rooms ⁹	—	—	—	0.5
Wood/metal shops ⁹	20	10	0.18	0.5
Food and beverage service				
Bars, cocktail lounges	100	7.5	0.18	—
Cafeteria, fast food	100	7.5	0.18	—
Dining rooms	70	7.5	0.18	—
Kitchens (cooking) ^b	20	7.5	0.12	0.7
Hotels, motels, resorts and dormitories				

Bathrooms/toilet—private ⁹	—	—	—	25/50 ^f
Bedroom/living room	10	5	0.06	—
Conference/meeting	50	5	0.06	—
Dormitory sleeping areas	20	5	0.06	—
Gambling casinos	120	7.5	0.18	—
Lobbies/prefunction	30	7.5	0.06	—
Multipurpose assembly	120	5	0.06	—
Offices				
Conference rooms	50	5	0.06	—
Main entry lobbies	10	5	0.06	—
Office spaces	5	5	0.06	—
Reception areas	30	5	0.06	—
Telephone/data entry	60	5	0.06	—
Private dwellings, single and multiple				
Garages, common for multiple units ^b	—	—	—	0.75
Kitchens ^b	—	—	—	25 50/100 ^f
Living areas ^c	Based on number of bedrooms. First bedroom, 2; each additional bedroom, 1	0.35 ACH but not less than 15 cfm/person	—	—
Toilet rooms and bathrooms ⁹	—	—	—	20 25/50 ^f
Public spaces				
Corridors	—	—	0.06	—
Courtrooms	70	5	0.06	—
Elevator car	—	—	—	1.0
Legislative chambers	50	5	0.06	—
Libraries	10	5	0.12	—
Museums (children's)	40	7.5	0.12	—
Museums/galleries	40	7.5	0.06	—
Places of religious worship	120	5	0.06	—
Shower room (per shower head) ⁹	—	—	—	50/20 ^f
Smoking lounges ^b	70	60	—	—
Toilet rooms — public ⁹	—	—	—	50/70 ^e
Retail stores, sales floors and showroom floors				
Dressing rooms	—	—	—	0.25
Mall common areas	40	7.5	0.06	—
Sales	15	7.5	0.12	—
Shipping and receiving	2	10	0.12	—
Smoking lounges ^b	70	60	—	—
Storage rooms	—	—	0.12	—
Warehouses (see "Storage")	—	10	0.06	—
Specialty shops				

Automotive motor-fuel dispensing stations ^b	—	—	—	1.5
Barber	25	7.5	0.06	0.5
Beauty salons ^b	25	20	0.12	0.6
Nail salons ^{b, h}	25	20	0.12	0.6
Embalming room ^b	—	—	—	2.0
Pet shops (animal areas) ^b	10	7.5	0.18	0.9
Supermarkets	8	7.5	0.06	—
Sports and amusement				
Bowling alleys (seating areas)	40	10	0.12	—
Disco/dance floors	100	20	0.06	—
Game arcades	20	7.5	0.18	—
Gym, stadium, arena (play area)	7	20	0.18	—
Health club/aerobics room	40	20	0.06	—
Health club/weight room	10	20	0.06	—
Ice arenas without combustion engines	—	—	0.30	0.5
Spectator areas	150	7.5	0.06	—
Swimming pools (pool and deck area)	—	—	0.48	—
Storage				
Repair garages, enclosed parking garages ^{b,d}	—	—	—	0.75
Refrigerated warehouses/freezers	—	10	—	0.75
Warehouses	—	10	0.06	—
Theaters				
Auditoriums (see "Education")	—	—	—	—
Lobbies	150	5	0.06	—
Stages, studios	70	10	0.06	—
Ticket booths	60	5	0.06	—
Transportation				
Platforms	100	7.5	0.06	—
Transportation waiting	100	7.5	0.06	—
Workrooms				
Bank vaults/safe deposit	5	5	0.06	—
Computer (without printing)	4	5	0.06	—
Copy, printing rooms	4	5	0.06	0.5
Darkrooms	—	—	—	1.0
Meat processing ^c	10	15	—	—
Pharmacy (prep. area)	10	5	0.18	—
Photo studios	10	5	0.12	—

For SI: 1 cubic foot per minute = 0.0004719 m³/s, 1 ton = 908 kg, 1 cubic foot per minute per square foot = 0.00508 m³/(s • m²), °C = [(°F) - 32]/1.8, 1 square foot = 0.0929 m².

- a. Based on *net occupiable floor area*.
- b. Mechanical exhaust required and the recirculation of air from such spaces is prohibited. Recirculation of air that is contained completely within such spaces shall not be prohibited (see Section 403.2.1, Item 3).
- c. Spaces unheated or maintained below 50°F are not covered by these requirements unless the occupancy is continuous.
- d. Ventilation systems in enclosed parking garages shall comply with Section 404.
- e. Rates are per water closet or urinal. The higher rate shall be provided where the exhaust system is designed to operate intermittently. The lower rate shall be permitted only where the exhaust system is designed to operate continuously while occupied.
- f. Rates are per room unless otherwise indicated. The higher rate shall be provided where the exhaust system is designed to operate intermittently. The lower rate shall be permitted only where the exhaust system is designed to operate continuously while occupied.
- g. Mechanical exhaust is required and recirculation from such spaces is prohibited except that recirculation shall be permitted where the resulting supply airstream consists of not more than 10 percent air recirculated from these spaces. Recirculation of air that is contained completely within such spaces shall not be prohibited (see Section 403.2.1, Items 2 and 4).
- h. For nail salons, each manicure and pedicure station shall be provided with a *source capture system* capable of exhausting not less than 50 cfm per station. Exhaust inlets shall be located in accordance with Section 502.20. Where one or more required source capture systems operate continuously during occupancy, the exhaust rate from such systems shall be permitted to be applied to the exhaust flow rate required by Table 403.3.1.1 for the nail salon.

Reason:

This proposal seeks to update the existing ventilation rate table in the IMC. Standard 62.1 is the source material for this table, and this updates table 403.3.1.1 to match the appropriate ventilation rates in 62.1-2016.

Bibliography:

ASHRAE Standard 62.1-2016

Cost Impact

The code change proposal will not increase or decrease the cost of construction .

This proposal revises ventilation rates for specific spaces within varying occupancy classifications. For systems where the exhaust airflow rate was increased, these systems also had a minimum and maximum ventilation rate based on the frequency of occupation within that space. The exhaust airflow values that were increased were the minimum values for kitchens and restrooms. These spaces are infrequently occupied, leading to the maximum value of exhaust ventilation being required. Therefore, this proposal does increase the cost of construction.

Internal ID: 354

M26-18

IMC: SECTION 403, 403.4 (New)

Proponent: Craig Conner, representing self (craig.conner@mac.com)

2018 International Mechanical Code

SECTION 403 MECHANICAL VENTILATION

Add new text as follows:

403.4 Devices venting combustion products into conditioned space. Permanently installed combustion appliances that are designed to vent combustion products into occupied conditioned space shall be approved by a licensed design professional.

Exception: Stoves, ovens and pilot lights.

Reason:

Combustion devices which are designed to vent combustion products into the conditioned space are high risk from the perspective of indoor air quality. These devices also increase interior moisture and can add contaminants such as NO_x (nitrous oxides).

Cost Impact

The code change proposal will increase the cost of construction .

There will likely be a cost associated with the review by a licensed design professional. However, it is also possible that the design professional will be less expensive than correcting any problem resulting from routinely venting combustion products into conditioned space.

Internal ID: 2011

M27-18

IMC: 403.3.1.1 (New), 403.3.1.1.1, 403.3.1.1.2 (New), 403.3.1.1.2.1 (New), 403.3.1.1.2.2 (New), 403.3.1.1.2.3 (New), 403.3.1.1.2.4 (New), 403.3.1.1.2.4.1 (New), 403.3.1.1.2.4.2 (New), 403.3.1.1.2.4.3 (New), 403.3.1.1.2.5 (New), 403.3.1.1.2.6 (New), 403.3.1.1.2.7 (New)

Proponent: Michael McFarland, enVerid Systems, representing enVerid Systems (mmcfarland@enverid.com)

2018 International Mechanical Code

Add new text as follows:

403.3.1.1 Outdoor Airflow Rate. The outdoor air flow rate shall comply with the ventilation rate procedure specified in Section 403.3.1.1.1 or the indoor air quality procedure specified in Section 403.3.1.1.2.

Revise as follows:

~~403.3.1.1~~ **403.3.1.1.1 Outdoor airflow rate-Ventilation Rate Procedure.** Ventilation systems shall be designed to have the capacity to supply the minimum outdoor airflow rate, determined in accordance with this section. In each occupiable space, the ventilation system shall be designed to deliver the required rate of outdoor airflow to the *breathing zone*. The occupant load utilized for design of the ventilation system shall be not less than the number determined from the estimated maximum occupant load rate indicated in Table ~~403.3.1.1~~ 403.3.1.1.1. Ventilation rates for occupancies not represented in Table ~~403.3.1.1~~ 403.3.1.1.1 shall be those for a listed *occupancy* classification that is most similar in terms of occupant density, activities and building construction; or shall be determined by an *approved* engineering analysis. The ventilation system shall be designed to supply the required rate of *ventilation air* continuously during the period the building is occupied, except as otherwise stated in other provisions of the code. With the exception of smoking lounges, the ventilation rates in Table ~~403.3.1.1~~ 403.3.1.1.1 are based on the absence of smoking in occupiable spaces. Where smoking is anticipated in a space other than a smoking lounge, the ventilation system serving the space shall be designed to provide ventilation over and above that required by Table ~~403.3.1.1~~ 403.3.1.1.1 in accordance with accepted engineering practice.

Exception: The occupant load is not required to be determined based on the estimated maximum occupant load rate indicated in Table ~~403.3.1.1~~ 403.3.1.1.1 where *approved* statistical data document the accuracy of an alternate anticipated occupant density.

Add new text as follows:

403.3.1.1.2 Indoor Air Quality Procedure. Ventilation systems shall be designed to have the capacity to supply the breathing zone outdoor airflow rate determined in accordance with Sections 403.3.1.1.2.1 through 403.3.1.1.2.7.

403.3.1.1.2.1 Contaminant Sources. Each contaminant of concern, for purposes of the design, shall be identified. For each contaminant of concern, indoor sources and outdoor sources shall be identified, and the emission rate for each contaminant of concern from each source shall be determined. Where two or more contaminants of concern target the same organ system, these contaminants shall be considered to be a contaminant mixture.

403.3.1.1.2.2 Contaminant Concentration. For each contaminant of concern, a concentration limit and its corresponding exposure period and an appropriate reference to a cognizant authority shall be specified. For each contaminant mixture of concern, the ratio of the concentration of each contaminant to its concentration limit shall be determined, and the sum of these ratios shall be not greater than one.

Exception: Consideration of odors in determining concentration limits shall not be required.

403.3.1.1.2.3 Perceived Indoor Air Quality. The design level of indoor air acceptability shall be specified in terms of the percentage of building occupants, visitors, or both expressing satisfaction with perceived IAQ.

403.3.1.1.2.4 Design Approach. Zone and system outdoor airflow rates shall be the larger of those determined in accordance with Section 403.3.1.1.2.4.1 and either Section 403.3.1.1.2.4.2 or 403.3.1.1.2.4.3, based on emission rates, concentration limits, and other relevant design parameters.

403.3.1.1.2.4.1 Mass Balance Analysis. Using a steady-state or dynamic mass-balance analysis, the minimum outdoor airflow rates required to achieve the concentration limits specified in Section 403.3.1.1.2.2 shall be determined for each contaminant or contaminant mixture of concern within each zone served by the system.

403.3.1.1.2.4.2 Subjective Evaluation. Using a subjective occupant evaluation conducted in the completed building, the minimum outdoor airflow rates required to achieve the level of

acceptability specified in Section 403.3.1.1.2.3 shall be determined within each zone served by the system.

403.3.1.1.2.4.3 Similar Zone. The minimum outdoor airflow rates shall be not less than those found in accordance with Section 403.3.1.1.2.4.2 for a substantially similar zone.

403.3.1.1.2.5 Air cleaning. Based on contaminant of concern sources and concentrations, particulate or gaseous air cleaning might be specified. Particulate matter filters and air cleaners shall report a third-party efficiency reporting value (MERV) in accordance with ASHRAE Standard 52.2. Gaseous scrubbers and air cleaners shall report a third-party efficiency test for the contaminants of concern in accordance with an approved standard and a third-party certification of no by-products production such as ozone, formaldehyde, and other VOCs. Devices that add pollutants to the indoor air, even in small quantities, are prohibited under this procedure.

403.3.1.1.2.6 Combined IAQ Procedure and Ventilation Rate Procedure. Where the IAQ Procedure is used in conjunction with the Ventilation Rate Procedure and applied to a zone or system, the Ventilation Rate Procedure shall be used to determine the required zone minimum outdoor airflow, and the IAQ Procedure shall be used to determine the additional outdoor air or air cleaning necessary to achieve the concentration limits of the contaminants and contaminant mixtures of concern.

403.3.1.1.2.7 Documentation. Where the IAQ Procedure is used, the following information shall be included in the design documentation: the contaminants and contaminant mixtures of concern considered in the design process, the sources and emission rates of the contaminants of concern, the concentration limits and exposure periods and the references for these limits, and the analytical approach used to determine ventilation rates and air-cleaning requirements. The contaminant monitoring and occupant or visitor evaluation plans shall also be included in the documentation.

Reason:

This proposal is to add ASHRAE 62.1 Indoor Air Quality Procedure (IAQP) as an alternative to determining outside airflow rates for mechanical ventilation (in buildings other than R-2, R-3, and R-4 three stories or less). Currently, the IMC Section 403 for mechanical ventilation only allows for ASHRAE 62.1 Ventilation Rate Procedure, as outlined in IMC 2018, Section 403.3.1.1. In this proposal, "403.3.1.1 Outdoor Airflow Rate" would become "403.3.1.1.1 Ventilation Rate Procedure" and all of its subsections would remain unchanged (except subsection numbering would change, for example, the first subsection would be 403.3.1.1.1.1, and so on, but these changes were not submitted to avoid confusion in the proposal). A new section "403.3.1.1.2 Indoor Air Quality Procedure" is added and uses the ASHRAE 62.1 IAQP text. In addition, Section "403.3.1.1 Outdoor Airflow Rate" will now simply introduce the two ventilation compliance options - 403.3.1.1.1 Ventilation Rate Procedure and 403.3.1.1.2 Indoor Air Quality Procedure.

The reasoning for adding ASHRAE 62.1 IAQP for determining outdoor airflow rates is as follows:

ASHRAE 62.1 is generally considered a leading authority on the topic of building ventilation. The standard has had the Indoor Air Quality Procedure (IAQP) since 1981, and has refined and improved it over the years. Adoption of this procedure is rapidly increasing among building owners, large corporations, property management firms, universities, and government institutions in the US and internationally (examples include: Apple, Google, Cisco, Morgan Stanley, Boston Properties, Hines, CBRE, ArcBest, United States GSA, United States American Embassy School, Univ of Miami, Univ of Tennessee, Harvard University, LSU, Diplomat Resorts, Air Liquide, Azrieli, Bank Leumi, China Europe International Business School, Elbit, and others. In addition, major mechanical engineering firms (MEP firms) have adopted the technology in their HVAC designs for clients, including Syska Hennessey, AHA, TLC Engineering, Haltom Engineering, and HRVAC Consulting Engineering, among others.

The rise in adoption is primarily due to new sorbent-based air cleaning technologies that address all molecular contaminants of concern inside buildings, and therefore can be used to clean and recycle indoor air so that less outside air is required for ventilation. There are several significant health and energy efficiency benefits to using less outside air:

1) "Fresh air" is no longer so fresh in big cities and near highways and airports. Studies show that living and working near a highway dramatically increases your risk of cardiovascular disease due to the higher concentrations of ultrafine particles and gases from automobiles that pass through normal particle filters. In addition, many major metropolitan areas frequently have high ozone action days as well as generally high particle pollution. Using typical mechanical ventilation rates specified in the IMC, many buildings replace their entire volume of indoor air with outside air every 1-2 hours, and therefore expose occupants to high volumes of these pollutants. With IAQP, air cleaning

technologies can be taken into consideration for managing indoor contaminant concentrations and lower outside airflow may be possible, which could reduce the influx of outdoor pollutants. Furthermore, some sorbent-based air cleaning technologies can remove outdoor pollutants such as ozone which are not captured by typical outside air filtration.

2) Energy codes are rightfully becoming more stringent, but are more and more difficult to achieve. Finding economical means to meet these energy codes is important. In addition, indoor environment quality needs to be maintained. According to the US EIA, HVAC accounts for nearly half of the energy consumption in US commercial buildings. In many climates, heating and/or cooling outside air ventilation can account for 30-50% of total HVAC energy consumption. When using IAQP with indoor air cleaning, outside airflow rates generally can be decreased quite significantly - often 60-70%, resulting in a 20-30% savings in annual HVAC energy consumption. This is a significant savings and is incremental to most other energy saving techniques.

3) Although building codes are followed at design and build stages, they are not typically followed in building operations. A high percentage of buildings are being operated with zero ventilation during summer and winter. In a survey to members of the International Facility Management Association (IFMA), 62% of them admitted to closing the outside air damper. The real percentage in the field is likely higher since those who close the outside air damper may have chosen not to complete the survey. There are numerous reasons for shutting off ventilation in a building: a) facility managers trying to reduce energy consumption due to financial incentives awarded for reducing utility bills, b) avoiding complaints when HVAC systems cannot manage the extra load introduced by outside air on extreme temperature days, c) HVAC designers will typically design systems to meet the load for 99% of the hours in the year, but this means roughly 90 hours - or 3 hours everyday for 30 days of a hot summer - require more cooling (or heating) capacity than the system can handle and therefore causing facility managers to simply close the outside air damper for the entire summer (or winter), and a very common situation is d) improperly positioned "freeze stats" that trigger the outside airflow to be closed off when temperatures reach 35 degrees F or lower. The best solution would be better enforcement of codes after occupancy. However, if these buildings had used IAQP with indoor air cleaning, at least the air cleaning would still be occurring even if outside airflow has been closed off and occupants would have better indoor air quality.

4) Lastly, the most significant reduction in HVAC load is on peak days. Thus, peak capacity of HVAC equipment can often be reduced by 20%, or even as high as 40%. This presents a significant capital expense savings in the construction or renovation of buildings, and in most designs, the addition of the sorbent-based air cleaning products will cause a net savings overall.

For all these reasons, the IMC should catch up to the ASHRAE 62.1 standard and include the Indoor Air Quality Procedure. The proposal uses this procedure almost verbatim, plus one additional section requiring filters and air cleaners to report third-party efficiency tests based on ASHRAE standardized tests 52.2 and 145.2. This section is added to ensure that the filters and air cleaners have proved their effectiveness for all contaminants of concern.

Bibliography:

ASHRAE 62.1 - 2016, Section 6.3 and Appendices C and E.

Cost Impact

The code change proposal will decrease the cost of construction .

The ASHRAE 62.1 Indoor Air Quality Procedure will likely be used when it can reduce the cost of construction, and this should occur in most sites due to reduction in chillers, AHU capacity, coolant piping size, outside air duct sizes, relief air ducts, and boiler/heating capacity.

Analysis: A review of the standard proposed for inclusion in the code, with regard to the ICC criteria for referenced standards (Section 3.6 of CP#28) will be posted on the ICC website on or before April 2, 2018.

Internal ID: 2072

M28-18

IMC: 403.3.2.5

Proponent: Pennie Feehan, representing Plumbing, Mechanical, and Fuel Gas Code Action Committee (PMGCAC@iccsafe.org)

2018 International Mechanical Code

Revise as follows:

403.3.2.5 Ventilating equipment. ~~Exhaust equipment serving single dwelling units~~ Fans providing exhaust or outdoor air shall be listed and labeled to provide the minimum required air flow in accordance with ANSI/AMCA 210-ANSI/ASHRAE 51.

Reason:

Industry experience and research have shown that "for advertised airflows that are not certified, the actual installed airflow can be a small fraction of the advertised value".¹ The 2018 IMC and IRC now require listing and labeling flows in accordance with ANSI/AMCA 210-ANSI/ASHRAE 51 for exhaust equipment serving single dwelling units. This requirement should be expanded to all fans under the scope of the ANSI standard to ensure that flows are reported on an equivalent basis. AMCA and HVI maintain listings of products tested in accordance with the standard.

This proposal is submitted by the ICC Plumbing/Mechanical/Gas Code Action Committee (PMG CAC). The PMG CAC was established by the ICC Board of Directors to pursue opportunities to improve and enhance the International Codes or portions thereof that were under the purview of the PMG CAC. In 2017 the PMG CAC held one face-to-face meeting and 11 conference call meetings. Numerous interested parties attended the committee meetings and offered their input.

Cost Impact

The code change proposal will not increase or decrease the cost of construction .

This proposal will not increase the cost of construction because no additional labor, materials, equipment, appliances or devices are mandated beyond what is currently required by the code.

Internal ID: 574

M29-18

IMC: 403.3.1.5, 608.1 (New)

Proponent: Pennie Feehan, representing Plumbing, Mechanical, and Fuel Gas Code Action Committee (PMGCAC@iccsafe.org)

2018 International Mechanical Code

Delete without substitution:

~~**403.3.1.5 Balancing.** The *ventilation* air distribution system shall be provided with means to adjust the system to achieve not less than the minimum ventilation airflow rate as required by Sections 403.3 and 403.3.1.2. Ventilation systems shall be balanced by an *approved* method. Such balancing shall verify that the ventilation system is capable of supplying and exhausting the airflow rates required by Sections 403.3 and 403.3.1.2.~~

Add new text as follows:

608.1 Balancing. Air distribution, ventilation and exhaust systems shall be provided with means to adjust the system to achieve the design airflow rates and shall be balanced by an approved method. Ventilation air distribution shall be balanced by an approved method and such balancing shall verify that the air distribution system is capable of supplying and exhausting the airflow rates required by Chapter 4.

Reason:

The second sentence of this section is relocated from Chapter 4 where it is out-of-place and often overlooked. The first sentence simply applies the same requirement to air distribution systems as is currently required for ventilation systems, because the code was silent on balancing for such systems.

This proposal is submitted by the ICC Plumbing/Mechanical/Gas Code Action Committee (PMG CAC). The PMG CAC was established by the ICC Board of Directors to pursue opportunities to improve and enhance the International Codes or portions thereof that were under the purview of the PMG CAC. In 2017 the PMG CAC held one face-to-face meeting and 11 conference call meetings. Numerous interested parties attended the committee meetings and offered their input.

Cost Impact

The code change proposal will not increase or decrease the cost of construction .

This proposal will not increase the cost of construction because no additional labor, materials, equipment, appliances or devices are mandated beyond what is currently required by the code.

Internal ID: 478

M30-18

IMC: 403.3.1.3

Proponent: Pennie Feehan, representing Plumbing, Mechanical, and Fuel Gas Code Action Committee (PMGCAC@iccsafe.org)

2018 International Mechanical Code

Revise as follows:

403.3.1.3 System operation. The minimum flow rate of outdoor air that the ventilation system must be capable of supplying during its operation shall be permitted to be based on the rate per person indicated in Table 403.3.1.1 and the actual number of occupants present. Where demand controlled ventilation is employed to adjust the outdoor air flow rate based on the actual number of occupants present, the minimum quantity of outdoor air shall not fall below that determined from the area outdoor airflow rate column of Table 403.3.1.1 during periods when the building is expected to be occupied.

Reason:

Demand control ventilation systems modulate outdoor airflow based on the number of occupants present in a space, and if zero occupants are detected, the ventilation airflow might be reduced to zero cfm. This scenario ignores the fact that the ventilation table in the IMC has two components; cfm rate per person and cfm rate per square foot of space. When the space is expected to be occupied, such as during business hours, the contaminants coming from the space contents still need to be diluted by ventilation air, therefore the cfm/SQ FT component of ventilation must not be shut off.

This proposal is submitted by the ICC Plumbing/Mechanical/Gas Code Action Committee (PMG CAC). The PMG CAC was established by the ICC Board of Directors to pursue opportunities to improve and enhance the International Codes or portions thereof that were under the purview of the PMG CAC. In 2017 the PMG CAC held one face-to-face meeting and 11 conference call meetings. Numerous interested parties attended the committee meetings and offered their input.

Cost Impact

The code change proposal will not increase or decrease the cost of construction .

This proposal will not increase the cost of construction because no additional labor, materials, equipment, appliances or devices are mandated beyond what is currently required by the code.

Internal ID: 486

M31-18

IMC: 407.1

Proponent: John Williams, Chair, representing Healthcare Committee (AHC@iccsafe.org)

2018 International Mechanical Code

Revise as follows:

407.1 General. Mechanical ventilation for ambulatory care facilities and Group I-2 occupancies shall be designed and installed in accordance with this code and ASHRAE 170- and NFPA 99.

Reason:

In addition to meeting the previous codes and standards referenced in this section in order to meet federal conditions of participation health care facilities must comply with the ventilation requirements listed in NFPA 99, Health Care Facilities Code (K521). This change will align the ventilation requirements for ambulatory care and Group I-2 facilities.

This proposal is submitted by the ICC Committee on Healthcare (CHC). The CHC was established by the ICC Board to evaluate and assess contemporary code issues relating to healthcare facilities. This is a joint effort between ICC and the American Society for Healthcare Engineering (ASHE), a subsidiary of the American Hospital Association, to eliminate duplication and conflicts in healthcare regulation. In 2017 the CHC held 2 open meetings and numerous conference calls, which included members of the committees as well as any interested parties, to discuss and debate the proposed changes. Information on the CHC, including: meeting agendas; minutes; reports; resource documents; presentations; and all other materials developed in conjunction with the CHC effort can be downloaded from the CHC website at: <https://www.iccsafe.org/codes-tech-support/cs/icc-committee-on-healthcare/>.

Cost Impact

The code change proposal will increase the cost of construction .

Costs will increase with this change because it will have additional ventilation requirements. However, it does not add cost to the healthcare industry because certified facilities already follow these requirements in the context of the federal standards.

Internal ID: 633

M32-18

IMC: 202 (New), 403.3.2.1

Proponent: Craig Conner, representing self (craig.conner@mac.com); Joseph Lstiburek, representing Self (joe@buildingsscience.com)

2018 International Mechanical Code

Add new definition as follows:

BALANCED VENTILATION. Any combination of concurrently operating mechanical exhaust and mechanical supply whereby the total mechanical exhaust airflow rate and the total mechanical supply airflow rate are substantially the same.

Revise as follows:

403.3.2.1 Outdoor air for dwelling units. An outdoor air ventilation system consisting of a mechanical exhaust system, supply system or combination thereof shall be installed for each dwelling unit. Local exhaust or supply systems, including outdoor air ducts connected to the return side of an air handler, are permitted to serve as such a system. The outdoor air ventilation system shall be designed to provide the required rate of outdoor air continuously during the period that the building is occupied. The minimum continuous outdoor airflow rate shall be determined in accordance with Equation 4-9.

$$Q_{OA} = 0.01A_{\text{floor}} + 7.5(N_{br} + 1)$$

(Equation 4-9)

where:

Q_{OA} = outdoor airflow rate, cfm

A_{floor} = conditioned floor area, ft²

N_{br} = number of bedrooms; not to be less than one

Exception-Exceptions:

1. The outdoor air ventilation system is not required to operate continuously where the system has controls that enable operation for not less than 1 hour of each 4-hour period. The average outdoor air flow rate over the 4-hour period shall be not less than that prescribed by Equation 4-9.
2. The minimum mechanical ventilation rate determined in accordance with Equation 4.9 shall be reduced by 25%, provided that all of the following conditions apply:
 - 2.1. A ducted system supplies recirculated air directly to each bedroom and the largest common area.
 - 2.2. For continuously operating systems, not less than 70% of the air volume in the conditioned space is recirculated each hour through the ducted system, or for intermittently operated systems, an equivalent air recirculation is provided during each four-hour period.
 - 2.3. The whole-house ventilation system is a balanced ventilation system.

Reason:

This code change credits the better performance of whole-building dilution ventilation systems that are distributed, mixed and balanced.

Distributed, mixed and balanced ventilation is more effective at controlling indoor contaminants than typical exhaust ventilation that provides no distribution and mixing. Exhaust ventilation can draw in contaminants from garages, attics, crawlspaces, soil and wall assemblies in single-family detached and multi-family construction as well as from neighboring units in multi-family construction. Ventilation that does not provide distribution and mixing can allow high levels of contaminant concentration in various spaces within houses, especially rooms where people spend a lot of time with doors closed such as bedrooms. Distribution and mixing homogenizes interior conditions reducing potentially harmful high intermittent contaminant concentrations in interior spaces. There are multiple ways to get to 70% mixing; for example, a recirculation mode that ensures that a central space conditioning system fan operates at least 20 minutes per hour would often meet the criteria for 70% air recirculation.

This code change does not penalize exhaust ventilation, it justifiably credits balanced ventilation. Exhaust only ventilation should not be given the same indoor air quality credit since typical exhaust ventilation systems result in less air change than balanced ventilation systems and do not provide as effective control of contaminants.

Cost Impact

The code change proposal will decrease the cost of construction .

The lower required ventilation rate recognizes that more effective ventilation requires less ventilation. This option could lower the cost of both construction and operation.

Internal ID: 1636

M33-18

IMC: 403.3, ordinal

Proponent: Mike Moore, representing The Home Ventilating Institute (mmoore@newportventures.net)

2018 International Mechanical Code

Revise as follows:

403.3 Outdoor air and local exhaust airflow rates. Group R-2, R-3 and R-4 occupancies three stories and less in height above grade plane shall be provided with outdoor air and local exhaust in accordance with Section 403.3.2-~~or~~ ASHRAE 62.2. Other buildings intended to be occupied shall be provided with outdoor air and local exhaust in accordance with Section 403.3.1.

Update standard(s) as follows:

ASHRAE

ASHRAE
1791 Tullie Circle NE
Atlanta GA 30329
US

~~ANSI/AMCA 210—ANSI/ASHRAE 51—07:~~

~~Laboratory Methods of Testing Fans for Aerodynamic Performance Rating~~

~~ASHRAE—2017:~~

~~ASHRAE Fundamentals Handbook~~

~~15—2016:~~

~~Safety Standard for Refrigeration Systems~~

~~34—2016:~~

~~Designation and Safety Classification of Refrigerants~~

~~62.1—2016:~~

~~Ventilation for Acceptable Indoor Air Quality~~

~~170—2017:~~

~~Ventilation of Health Care Facilities~~

~~180—2012:~~

~~Standard Practice for Inspection and Maintenance of Commercial Building HVAC Systems~~

~~62.2-2016:~~

~~Ventilation and Acceptable Indoor Air Quality in Residential Buildings with Addenda b, d, k, l, q, and s~~

Reason:

This proposed modification would provide ventilation system designers/specifiers of low-rise dwelling units with the OPTION of using ASHRAE Standard 62.2 to comply with the ventilation requirements of the IMC without requiring designers/specifiers to use the standard. ASHRAE 62.2 is the ANSI standard for establishing minimum acceptable indoor air quality for dwelling units. There are several reasons that designers/specifiers may want to use ASHRAE 62.2 instead of the IMC for compliance, including: greater flexibility for specifying climate-appropriate ventilation controls, ability to achieve energy and cost savings for homeowners by shifting operation of the ventilation system to times when ambient temperature and humidity are favorable, flexibility to specify innovative systems that can be demonstrated to provide equivalent exposure to pollutants, ability to down-size and save money on balanced ventilation equipment versus what may be required by the code, and 62.2's use by code-plus programs such as ENERGY STAR and LEED.

Cost Impact

The code change proposal will not increase or decrease the cost of construction .

Costs of compliance with 62.2 versus alternative compliance paths will vary based on the application. This proposal gives builders the OPTION of using 62.2, meaning there will be no required increase or decrease in the cost of construction.

Internal ID: 591

M34-18

IMC: 501.2, 504.1, 505.3,

Proponent: Guy McMann, representing Colorado Association of Plumbing and Mechanical Officials (CAPMO)
(gcmcmann@jeffco.us)

2018 International Mechanical Code

Revise as follows:

501.2 Independent system required. Single or combined mechanical exhaust systems for environmental air shall be independent of all other exhaust systems. Dryer, domestic kitchen and hazardous exhaust shall be independent of all other systems. Type I exhaust systems shall be independent of all other exhaust systems except as provided in Section 506.3.5. Single or combined Type II exhaust systems for food-processing operations shall be independent of all other exhaust systems. ~~Kitchen-Commercial kitchen~~ exhaust systems shall be constructed in accordance with ~~Section 505 for domestic cooking operations and Sections 506 through 509, for commercial cooking operations.~~

504.1 Installation. Clothes dryers shall be exhausted in accordance with the manufacturer's instructions. Dryer exhaust systems shall ~~be independent of all other systems and shall convey the moisture and any products of combustion to the outside of the building.~~

Exception: This section shall not apply to listed and labeled condensing (ductless) clothes dryers.

505.3 Exhaust ducts. Domestic cooking exhaust equipment shall discharge to the outdoors through sheet metal ducts constructed of galvanized steel, stainless steel, aluminum or copper. Such ducts shall have smooth inner walls, shall be air tight, ~~and shall be equipped with a backdraft damper, and shall be independent of all other exhaust systems.~~ Installations in Group I-1 and I-2 occupancies shall be in accordance with the International Building Code and Section 904.13 of the International Fire Code.

Exceptions:

1. In other than Groups I-1 and I-2, where installed in accordance with the manufacturer's instructions and where mechanical or natural ventilation is otherwise provided in accordance with Chapter 4, listed and labeled ductless range hoods shall not be required to discharge to the outdoors.
2. Ducts for domestic kitchen cooking appliances equipped with downdraft exhaust systems shall be permitted to be constructed of Schedule 40 PVC pipe and fittings provided that the installation complies with all of the following:
 - 2.1. The duct shall be installed under a concrete slab poured on grade.
 - 2.2. The underfloor trench in which the duct is installed shall be completely backfilled with sand or gravel.
 - 2.3. The PVC duct shall extend not more than 1 inch (25 mm) above the indoor concrete floor surface.
 - 2.4. The PVC duct shall extend not more than 1 inch (25 mm) above grade outside of the building.
 - 2.5. The PVC ducts shall be solvent cemented.

Delete without substitution:

~~**510.4 Independent system.** Hazardous exhaust systems shall be independent of other types of exhaust systems.~~

Reason:

This is strictly an editorial clean up as the code doesn't have to keep repeating itself.

Cost Impact

The code change proposal will not increase or decrease the cost of construction.

This is strictly editorial.

Internal ID: 128

M35-18

IMC: 502.20, 502.20.1 (New)

Proponent: Guy McMann, representing Colorado Association of Plumbing and Mechanical Officials (CAPMO)
(gcmann@jeffco.us)

2018 International Mechanical Code

Add new text as follows:

502.20 Manicure and pedicure stations. Manicure and pedicure stations shall be provided with an exhaust system in accordance with Table 403.3.1.1, Note h. Manicure tables and pedicure stations not provided with factory-installed exhaust inlets shall be provided with exhaust inlets located not more than 12 inches (305 mm) horizontally and vertically from the point of chemical application.

502.20.1 Operation. The exhaust system for manicure and pedicure stations shall have controls that operate the system continuously when the space is occupied.

Reason:

Measures need to be taken that will prevent the exhaust system from being turned off after the inspection process is over. There are some 200,000 Nail Salons in the US employing some 375,000 people. Some of the chemicals employed in this process are acetone, isopropyl alcohol, Butyl acetate, dibutyl phthalate, ethyl acetate, ethyl methacrylate, formaldehyde, methacrylate, toluene, including nail dust and nail fungus. Many operators simply turn off the exhaust system simply because it's too noisy there by putting the clients and employees at risk to these toxic fumes. Sometimes they are turned off to save on energy costs. When the fumes become overpowering the technicians end up opening doors to deal with the built up fumes even in the winter. This is an unacceptable situation that can easily be avoided. The same theory applies to kitchen exhaust systems. Requiring the system to operate at all times while occupied and operating will result in less fugitive vapors that can harm individuals.

Cost Impact

The code change proposal will increase the cost of construction .

This could **possibly** increase cost in that it would take some coordination to interlock the power source with maybe the lights or some other automatic way of turning on the system.

Internal ID: 133

M36-18

IMC: 501.6 (New)

Proponent: Pennie Feehan, representing Plumbing, Mechanical, and Fuel Gas Code Action Committee (PMGCAC@iccsafe.org)

2018 International Mechanical Code

Add new text as follows:

501.6 Common ducts. Exhaust fan ducts that are under positive pressure shall not be connected to a common duct or shaft, except where the common duct or shaft is maintained at a negative pressure. The discharge outlet of exhaust fans that serve separate dwelling or sleeping units shall not be connected to a common duct or shaft, except where the common duct or shaft is maintained at a negative pressure.

Reason:

Exhaust ducts that are under positive pressure cannot be joined because the airflow from one fan will leak out through the fan that is not running. Only if the fans that share an exhaust duct are all running simultaneously, could backflow be prevented. Backdraft dampers in common exhaust fans have a significant leakage rate, thus the fan that is not running will see backflow from the common duct and the exhaust air from one space will dump into another space. If the fans discharge to a common exhaust shaft that is under negative pressure, there is no problem and this proposal would not prevent that arrangement. It is extremely undesirable (and unthinkable) to use a common duct for fans that serve different dwelling and sleeping units because odors, smoke, pathogens, chemical irritants, etc. would be carried from one unit to another.

This proposal is submitted by the ICC Plumbing/Mechanical/Gas Code Action Committee (PMG CAC). The PMG CAC was established by the ICC Board of Directors to pursue opportunities to improve and enhance the International Codes or portions thereof that were under the purview of the PMG CAC. In 2017 the PMG CAC held one face-to-face meeting and 11 conference call meetings. Numerous interested parties attended the committee meetings and offered their input.

Cost Impact

The code change proposal will increase the cost of construction .

This proposal will increase the cost of construction only where the cost of an additional roof, wall or soffit penetration is more than the cost of larger common ducts, tee and wye fittings, fasteners, sealants and hangers and the extra labor to assemble common duct arrangements.

This proposal will increase the cost of construction if additional roof or wall penetrations cost more than combined exhaust discharge ducts. Combining ducts into a common duct adds material costs, as does making roof and wall penetrations.

Internal ID: 561

M37-18

IMC: 504.8.3

Proponent: Pennie Feehan, representing Plumbing, Mechanical, and Fuel Gas Code Action Committee (PMGCAC@iccsafe.org)

2018 International Mechanical Code

Revise as follows:

504.8.3 Transition ducts. Transition ducts used to connect the dryer to the exhaust duct system shall be a single length that is *listed* and *labeled* in accordance with UL 2158A. Transition ducts shall be not greater than 8 feet (2438 mm) in length and shall not be concealed within construction. The installation of transition ducts shall be in accordance with the dryer manufacturer's installation instructions.

Reason:

Dryer manufacturers will specify in their installation instructions whether or not transition ducts are allowed. The use of transition ducts must be consistent with the appliance installation instructions.

This proposal is submitted by the ICC Plumbing/Mechanical/Gas Code Action Committee (PMG CAC). The PMG CAC was established by the ICC Board of Directors to pursue opportunities to improve and enhance the International Codes or portions thereof that were under the purview of the PMG CAC. In 2017 the PMG CAC held one face-to-face meeting and 11 conference call meetings. Numerous interested parties attended the committee meetings and offered their input.

Cost Impact

The code change proposal will not increase or decrease the cost of construction .

This proposal will not increase the cost of construction because no additional labor, materials, equipment, appliances or devices are mandated beyond what is currently required by the code.

Internal ID: 378

M38-18

IMC: 504.4.2 (New)

Proponent: Rick Harpenau, representing self (rick@dryerbox.com)

2018 International Mechanical Code

Add new text as follows:

504.4.2 Animal Grill. Where grilles are provided on dryer exhaust duct terminals to prevent entry of animals, the grille shall consist entirely of vertical slots without horizontal or diagonal members, the slots shall have a width of not less than 5/8 inch (15.9 mm), and the total open area of the grille shall be not less than 4 times the opening area of the exhaust duct.

Reason:

Rural areas across our country experience sufficient intrusion of squirrels, rodents and birds. So much so that homeowners seek or create their own protection. Many resort to mechanical cloth wraps with wire spacing of less than ½". Plastic grilles are common as well but due to the lack of material strength, the grill partitions are large and flat promoting accelerated lint build up. Some plastic wall vent hoods incorporate an integral defensive grill. Generally, this design does not provide an adequate area spread and aperture size of each opening is insufficient to allow the lint accumulation to release and exit.

Currently Section 504.4 clearly indicates screens shall not be installed at the duct termination. Grilles and screens could be considered equivalent in description causing confusion. A separate section defining acceptable grilles seems logical and removes the equal comparison argument for grilles and screens and their use at or near the dryer termination.

Vertical bars resist accelerated lint build up.

The text simply lays out criteria for cages to feature vertical bars.



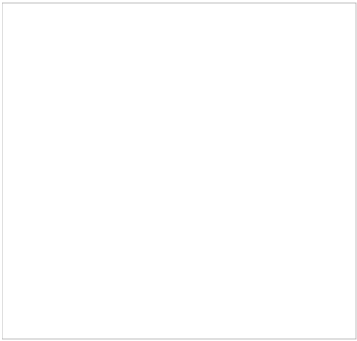







Bibliography:

Inventor of the Dryerbox. Owner of In-O-Vate Technologies Inc.

Cost Impact

The code change proposal will not increase or decrease the cost of construction .

A rodent/bird defensive grill or cage is an owner/occupant discretionary item. Wording is necessary to distinguish grills from disallowed screens.

Internal ID: 338

M39-18

IMC: 504.4, 504.8.2

Proponent: Rick Harpenau, representing self (rick@dryerbox.com)

2018 International Mechanical Code

Revise as follows:

504.4 Exhaust installation. Dryer exhaust ducts for clothes dryers shall terminate on the outside of the building and shall be equipped with a backdraft damper. Screens shall not be installed at the duct termination. ~~Ducts shall not be connected or installed with sheet metal screws or other fasteners that will obstruct the exhaust flow.~~ Clothes dryer exhaust ducts shall not be connected to a vent connector, vent or *chimney*. Clothes dryer exhaust ducts shall not extend into or through ducts or plenums. ~~Clothes dryer exhaust ducts shall be sealed in accordance with Section 603.9.~~

504.8.2 Duct installation. Exhaust ducts shall be supported at ~~4-foot intervals~~ not to exceed 4 feet (1219 mm) intervals and shall be secured in place. The insert end of the duct shall extend into the adjoining duct or fitting in the direction of airflow. Exhaust duct joints shall be sealed in accordance with Section 603.9 and shall be mechanically fastened. Ducts shall not be joined with screws or similar fasteners that protrude more than 1/8 inch (3.2 mm) into the inside of the duct.

Where dryer exhaust ducts are enclosed in wall or ceiling cavities, such cavities shall allow the installation of the duct without deformation.

Reason:

Like the Residential Code M1502, installation details are covered in one spot under Duct Installation. For consistency it seems appropriate to list the details in one section and under the same section title. In reading 504.4 and 504.8.2 it is unclear if mechanical fastening is required or not. This revision places mechanical fastening in one place and provides a much clearer version.

The italicized formatting of the word Chimney seems unnecessary.

These changes bring clarity and consistency to the sections and format between the Res and Mech codes.

These images show the importance of both mechanical fastening, seam taping and 4 foot interval support spacing.



Bibliography:

Inventor of the Dryerbox receptacle and owner of In-O-Vate Technologies Inc since 1996

Cost Impact

The code change proposal will not increase or decrease the cost of construction .

This proposal is for consistency and clarification. No cost increase or decrease is involved.

Internal ID: 322

M40-18

IMC: 506.3.2.5

Proponent: Connor Barbaree, ASHRAE, representing ASHRAE (cbarbaree@ashrae.org)

2018 International Mechanical Code

Revise as follows:

506.3.2.5 Grease duct test. Prior to the use or concealment of any portion of a grease duct system, a leakage test shall be performed. Ducts shall be considered to be concealed where installed in shafts or covered by coatings or wraps that prevent the ductwork from being visually inspected on all sides. The permit holder shall be responsible to provide the necessary *equipment* and perform the grease duct leakage test. ~~A light test~~ One of the following tests shall be performed to determine that all welded and brazed joints are liquid tight.

1. A water spray test as prescribed in this section
2. Where approved, a light test as prescribed in this section
3. An approved equivalent test

A light test shall be performed by passing a lamp having a power rating of not less than 100 watts through the entire section of ductwork to be tested. The lamp shall be open so as to emit light equally in all directions perpendicular to the duct walls. A test shall be performed for the entire duct system, including the hood-to-duct connection. The duct work shall be permitted to be tested in sections, provided that every joint is tested. For *listed* factory-built grease ducts, this test shall be limited to duct joints assembled in the field and shall exclude factory welds.

A water test shall be performed by simulating a grease duct cleaning operation by use of a pressure washer that is designed for grease duct cleaning and that operates at a pressure of not less than 1500 psi. The water shall be applied directly to all areas to be tested. Water applied to the duct interior surfaces shall not be visible on any exterior surfaces of the duct during the test.

Reason:

The flexibility within this proposal will allow the code official some discretion to decide which duct test has worked best in the past and which to apply to the current installation.

Based upon information from industry, code officials and end users, there are alternative methods of duct leakage testing currently being used successfully by industry. The intent of the language is to not limit the user to the light test or prohibit other methods where approved by local authority having jurisdiction. As an example, the State of Minnesota 2015 Mechanical and Fuel Gas Code has options of a light, air or water test. Additionally, there has been questions regarding the effectiveness of the light test to find pinhole leaks and leaks around over-lapping joints.

ASHRAE Standard 154-2016 "Ventilation for Commercial Cooking Operations" included the alternate water or approved equivalent tests during the last revision cycle. The proposed language harmonizes the two documents.

A recent committee member reported to the Standard 154 committee regarding comments from IKECA regarding leak testing. IKECA's recommendation was a water pressure test. Their comments included that the light test is ineffective, especially on pinhole leaks covered by slag. The water pressure washing without detergent prior to wrapping the duct is the most effective method to find leaks. Contractors bristle at this initially, but when told that this is the same conditions the duct will be subjected to at the first duct cleaning they are more receptive. As a result, some contractors are beginning to require that this test be performed before wrapping to ensure there are no leaks, and this helps them in that they are not called back at a later date to fix leaking exhaust ducts.

Bibliography:

ASHRAE Standard 154-2016 "Ventilation for Commercial Cooking Operations"

Cost Impact

The code change proposal will not increase or decrease the cost of construction .

This proposal seeks to add flexibility on behalf of the AHJ in reference to grease duct testing and does not impact how the grease duct itself is constructed. Therefore, it does not increase the cost of construction.

Internal ID: 1542

M41-18

IMC: 506.3.2.5

Proponent: Connor Barbaree, ASHRAE, representing ASHRAE (cbarbaree@ashrae.org)

2018 International Mechanical Code

Revise as follows:

506.3.2.5 Grease duct test. Prior to the use or concealment of any portion of a grease duct system, a leakage test shall be performed. Ducts shall be considered to be concealed where installed in shafts or covered by coatings or wraps that prevent the ductwork from being visually inspected on all sides. The permit holder shall be responsible to provide the necessary *equipment* and perform the grease duct leakage test. A light test, water spray test, or approved equivalent test shall be performed to determine that all welded and brazed joints are liquid tight.

A light test shall be performed by passing a lamp having a power rating of not less than 100 watts through the entire section of ductwork to be tested. The lamp shall be open so as to emit light equally in all directions perpendicular to the duct walls. A test shall be performed for the entire duct system, including the hood-to-duct connection. The duct work shall be permitted to be tested in sections, provided that every joint is tested. For *listed* factory-built grease ducts, this test shall be limited to duct joints assembled in the field and shall exclude factory welds.

A water test shall be performed by simulating a grease duct cleaning operation by use of a pressure washer that is designed for grease duct cleaning, and that operates at a pressure of not less than 1500 psi. The water shall be applied directly to all areas to be tested. Water applied to the duct interior surfaces shall not be visible on any exterior surfaces of the duct during the test.

Reason:

Based upon information from industry, code officials and end users, there are alternative methods of duct leakage testing currently being used successfully by industry. The intent of the language is to not limit the user to the light test or prohibit other methods where approved by local authority having jurisdiction. As an example, the State of Minnesota 2015 Mechanical and Fuel Gas Code has options of a light, air or water test. Additionally, there has been questions regarding the effectiveness of the light test to find pinhole leaks and leaks around over-lapping joints.

ASHRAE Standard 154-2016 “Ventilation for Commercial Cooking Operations” included the alternate water or approved equivalent tests during the last revision cycle. The proposed language harmonizes the two documents.

A recent committee member reported to the Standard 154 committee regarding comments from IKECA regarding leak testing. IKECA’s recommendation was a water pressure test. Their comments included that the light test is ineffective, especially on pinhole leaks covered by slag. The water pressure washing without detergent prior to wrapping the duct is the most effective method to find leaks. Contractors bristle at this initially, but when told that this is the same conditions the duct will be subjected to at the first duct cleaning they are more receptive. As a result, some contractors are beginning to require that this test be performed before wrapping to ensure there are no leaks, and this helps them in that they are not called back at a later date to fix leaking exhaust ducts.

Bibliography:

ASHRAE Standard 154-2016 “Ventilation for Commercial Cooking Operations”

Cost Impact

The code change proposal will not increase or decrease the cost of construction .

This proposal seeks to add flexibility on behalf of the AHJ in reference to grease duct testing and does not impact how the grease duct itself is constructed. Therefore, it does not increase the cost of construction.

Internal ID: 1103

M42-18

IMC: 507.2.6.1 (New)

Proponent: Drew Dorrance, South Salt Lake City, representing South Salt Lake City (drd_007@hotmail.com); Don Davies (don.davies@slcgov.com)

2018 International Mechanical Code

Add new text as follows:

507.2.6.1 Clearance for glazing from Type 1 hood. Glazing installed within 18 inches (457 mm) of a Type 1 hood shall be tempered and rated for 900 degrees fahrenheit. Window frames shall meet the requirements of Section 507.2.6, and the cooking appliance installation instructions.

Reason:

Currently windows are being installed near ranges, and type 1 hoods with no guidelines in the mechanical code. As long as the glazing is non-combustible it can currently be installed in a potentially hazardous situation. Glazing that is both heat treated and tempered adds protection to bystanders. For example there are situations where restaurants want patrons to watch their food be prepared on the grill.

Cost Impact

The code change proposal will increase the cost of construction .

The code change proposal will increase the cost of construction. The cost would be related to the price of heat-treated and tempered glazing.

Internal ID: 1467

M43-18

IMC: 510.6.5

Proponent: Guy McMann, Jefferson County Colorado, representing Colorado Association of Plumbing and Mechanical Officials (CAPMO) (gcmann@jeffco.us)

2018 International Mechanical Code

Revise as follows:

510.6.5 Makeup air. *Makeup air from all sources shall be provided during operations at a rate approximately equal to the rate that air is exhausted by the hazardous exhaust system. Makeup air shall be provided by gravity or mechanical means or both. Mechanical makeup air systems shall be automatically controlled to start and operate simultaneously with the exhaust system. The makeup air shall not reduce the effectiveness of the exhaust system. Makeup air intakes shall be located in accordance with Section 401.4.*

Reason:

This is strictly an editorial cleanup with no new requirements. This section lacks the pertinent information that designers need to be aware of when using this Section.

Cost Impact

The code change proposal will not increase or decrease the cost of construction .

This is strictly an editorial proposal.

Internal ID: 914

M44-18

IMC: 510.7.2, 510.7.3

Proponent: Guy McMann, Jefferson County Colorado, representing Colorado Association of Plumbing and Mechanical Officials (CAPMO) (gcmcmann@jeffco.us)

2018 International Mechanical Code

Revise as follows:

510.7.2 Floors. Hazardous exhaust systems that penetrate a floor/ceiling assembly shall comply with one of the following:

1. Exhaust ducts shall be enclosed in a fire-resistance-rated shaft constructed in accordance with the International Building Code- or
2. The duct shall be provided with a field applied duct enclosure material, system, product or method of construction specifically evaluated for such purpose in accordance with ASTM E 2336. The surface of the duct shall be continuously covered on all sides from the point at which the duct originates to the outlet terminal. Duct penetrations shall be protected with a through-penetration fire stop system tested and listed in accordance with ASTM E 814 or UL 1479 and having a "F" and "T" rating equal to the fire resistance rating of the assembly being penetrated. The duct enclosure and fire stop system shall be installed in accordance with the listing and the manufacturers instructions. Exposed duct wrap systems shall be protected where subject to physical damage.

510.7.3 Wall assemblies. Hazardous exhaust duct systems that penetrate fire-resistance-rated wall assemblies shall be enclosed in fire-resistance-rated construction from the point of penetration to the outlet terminal, except where the interior of the duct is equipped with an approved automatic fire suppression system. Ducts shall be enclosed in accordance with the International Building Code requirements for shaft construction and such enclosure shall have a minimum fire-resistance rating of not less than the highest fire-resistance-rated wall assembly penetrated.

Exception: Exhaust ducts shall not be required to be installed in a shaft where a field applied duct enclosure material, system, product or method of construction specifically evaluated for such purpose in accordance with ASTM E 2336. The surface of the duct shall be continuously covered on all sides from the point at which the duct originates to the outlet terminal. Duct penetrations shall be protected with a through-penetration fire stop system tested and listed in accordance with ASTM E 814 or UL 1479 and having a "F" and "T" rating equal to the fire resistance rating of the assembly being penetrated. The duct enclosure and fire stop system shall be installed in accordance with the listing and the manufacturers instructions. Exposed duct wrap systems shall be protected where subject to physical damage.

Reason:

Various manufacturers of duct wrap materials have listings that apply to HVAC ducts that provide one and two hour fire resistant ratings. There are times where building a shaft is not practical or possible. This proposal recognizes the benefits of flexibility these systems provide and should be an option for the designers. These systems have been proved to be very effective in commercial kitchen systems and should be an option in this situation. To always require a shaft isn't practical when there is a perfectly good alternative.

Cost Impact

The code change proposal will not increase or decrease the cost of construction .

This Proposal has the potential to decrease costs by not having to construct a shaft using conventional materials and methods. Savings in labor costs may also be realised .

Internal ID: 625

M45-18

IMC: 507.1

Proponent: Guy McMann, representing Colorado Association of Plumbing and Mechanical Officials (CAPMO)
(gcmcmann@jeffco.us)

2018 International Mechanical Code

Revise as follows:

507.1 General. Commercial kitchen exhaust hoods shall comply with the requirements of this section. Hoods shall be Type I or II and shall be designed to capture and confine cooking vapors and residues. A Type I or Type II hood shall be installed at or above appliances in accordance with Sections 507.2 and 507.3. Where any cooking appliance under a single hood requires a Type I hood, a Type I hood shall be installed. Where a Type II hood is required, a Type I or Type II hood shall be installed. Where a Type I hood is installed, the installation of the entire system, including the hood, ducts, exhaust equipment and makeup air system shall comply with the requirements of Sections 506, 507, 508 and 509.

Exceptions:

1. Factory-built commercial exhaust hoods that are listed and labeled in accordance with UL 710, and installed in accordance with Section 304.1, shall not be required to comply with Sections 507.1.5, 507.2.3, 507.2.5, 507.2.8, 507.3.1, 507.3.3, 507.4 and 507.5.
2. Factory-built commercial cooking recirculating systems that are listed and labeled in accordance with UL 710B, and installed in accordance with Section 304.1, shall not be required to comply with Sections 507.1.5, 507.2.3, 507.2.5, 507.2.8, 507.3.1, 507.3.3, 507.4 and 507.5. Spaces in which such systems are located shall be considered to be kitchens and shall be ventilated in accordance with Table 403.3.1.1. For the purpose of determining the floor area required to be ventilated, each individual appliance shall be considered as occupying not less than 100 square feet (9.3 m²).
3. Where cooking appliances are equipped with integral down-draft exhaust systems and such appliances and exhaust systems are listed and labeled for the application in accordance with NFPA 96, a hood shall not be required at or above them.
4. Smoker ovens with integral exhaust systems provided that the appliance is installed in accordance with the manufacturer's installation instructions, is listed and tested for the application and complies with Chapter 5

Reason:

Not all smokers are created equal. Just because they are categorized as a Heavy-Duty Appliance shouldn't necessarily require them to be located under a type I hood when they have an integral exhaust system. Some of these units are equipped with evacuators and flue collectors which won't let any smoke out when the doors open. When the option to use standard exhaust systems that eliminate the possibility for smoke to escape into the kitchen, requiring them to be located under a hood isn't necessary. The blanket statement that all smoker ovens must be located under a hood regardless of the situation doesn't represent the technology that's available with these units and an exception is appropriate in these cases.

Cost Impact

The code change proposal will not increase or decrease the cost of construction .

This is a cost neutral proposal.

Internal ID: 127

M46-18

IMC: 507.6.1

Proponent: Guy McMann, representing Colorado Association of Plumbing and Mechanical Officials (CAPMO)
(gcmann@jeffco.us)

2018 International Mechanical Code

Revise as follows:

507.6.1 Capture and containment test. The permit holder shall verify capture and containment performance of the exhaust system. This field test shall be conducted with all appliances under the hood at operating temperatures, with all sources of outdoor air providing makeup air for the hood operating and with all sources of recirculated air providing conditioning for the space in which the hood is located operating. Capture and containment shall be verified visually by observing smoke or steam produced by actual or simulated cooking, such as that provided by smoke candles and smoke puffers. ~~Smoke bombs shall not be used.~~generators.

Reason:

The term "smoke generators" includes all forms of smoke producing products and smoke bombs are the very best way to test a hood system. We want to take the system to the extreme just as we do testing grease ducts to 2000 degrees. Smoke bombs do not produce unrealistic examples of real cooking procedures and actually the decision should be left to the code official to determine what the best way to test is depending on the duty of the system. This passed last cycle at the committee level and was overturned at the public comment period.

Cost Impact

The code change proposal will not increase or decrease the cost of construction .

This proposal is editorial in nature.

Internal ID: 134

M47-18

IMC: 506.3.9

Proponent: Guy McMann, representing Colorado Association of Plumbing and Mechanical Officials (CAPMO) (gcmann@jeffco.us)

2018 International Mechanical Code

Revise as follows:

506.3.9 Grease duct horizontal cleanouts. Cleanouts serving horizontal sections of grease ducts shall:

1. Be spaced not more than 20 feet (6096 mm) apart.
2. Be located not more than 10 feet (3048 mm) from changes in direction that are greater than 45 degrees (0.79 rad).
3. Be located on the bottom only where other locations are not available and shall be provided with internal damming of the opening such that grease will flow past the opening without pooling. Bottom cleanouts and openings shall be approved for the application and installed liquid-tight.
4. Not be closer than 1 inch (25 mm) from the edges of the duct.
5. Have opening dimensions of not less than 12 inches by 12 inches (305 mm by 305 mm). Where such dimensions preclude installation, the opening shall be not less than 12 inches (305 mm) on one side and shall be large enough to provide access for cleaning and maintenance.
6. ~~Shall be~~ Be located at grease reservoirs.
7. Be located within 3 feet of horizontal discharge fans.

Reason:

There are times when it's not practical to expect maintenance personnel to open a hinged fan on the side of a building especially if it's higher than 10. Some fans are very large and could be unsafe to attempt to open it. A much safer and simpler solution is to install a clean-out within a close distance so as to clean and service the fan from the inside.

Cost Impact

The code change proposal will increase the cost of construction .

The increase in cost would amount to an additional cleanout installed near the fan discharge.

Internal ID: 123

M48-18

IMC: 504.8.2

Proponent: James Tinner, representing City of Bellingham Washington (jetinner@cob.org)

2018 International Mechanical Code

Revise as follows:

504.8.2 Duct installation. Exhaust ducts shall be supported at 4-foot (1219 mm) intervals and secured in place. The insert end of the duct shall extend into the adjoining duct or fitting in the direction of airflow. Joists in ducts shall be mechanically fastened on at least two opposing sides by rivets, screws or similar fasteners. Ducts shall not be joined with screws or similar fasteners that protrude more than $\frac{1}{8}$ inch (3.2 mm) into the inside of the duct. Tapes or mastics shall not be deemed adequate to fasten duct joints.

Where dryer exhaust ducts are enclosed in wall or ceiling cavities, such cavities shall allow the installation of the duct without deformation.

Reason:

Failure of dryer exhaust duct joints is common and can cause significant damage if the failure is not observed and corrected. IRC Section M1502.4.2 already contains language requiring mechanical connections of dryer duct joints. I intend to submit a code change proposal in the IRC to clarify that tapes and mastics are not adequate to secure dryer duct joints.

Cost Impact

The code change proposal will increase the cost of construction .

The change will add a few minutes to the time needed to mechanically fasten dryer duct joints. The cost increase will be minimal but will exist.

Internal ID: 104

M49-18

IMC: 507.2

Proponent: John Addario, NYS Department of State Division of Building Standards and Codes, representing New York State Department of State - Division of Building Standards and Codes (john.addario@dos.ny.gov)

2018 International Mechanical Code

Revise as follows:

507.2 Type I hoods. Type I hoods shall be installed where cooking *appliances* produce grease or smoke as a result of the cooking process. Type I hoods shall be installed over *medium-duty, heavy-duty and extra-heavy-duty cooking appliances*.

Exception: A Type I hood shall not be required ~~for an electric cooking appliance where not more than two electric cooking appliances are installed per room and~~ where an approved testing agency provides documentation that ~~the~~ each appliance effluent contains 5 mg/m³ or less of grease when tested at an exhaust flow rate of 500 cfm (0.236 m³/s) in accordance with UL 710B.

Reason:

The current code has an exception for the requirement for a Type I hood for electric cooking appliances when the effluent contains 5 mg/m³ or less grease output. The proposed modification would allow an exception for, two or less electric cooking appliances installed under a single hood, when the effluent contains 5 mg/m³ or less grease per unit. The proposed modification recognizes that the output of grease may not be great enough to require a Type I hood when you have just one unit installed under a single hood. In some situations, several of these units are installed and grouped together, some of these units are specifically designed to be stacked on top of one another. Obviously, the need for multiple units increases the output of the total amount of grease created and justifies the fact that a Type I hood should be required. The proposed modification would continue to provide relief for two or less electric appliances which individually don't exceed a maximum output level of grease.

Cost Impact

The code change proposal will increase the cost of construction .

The costs would remain the same when two or less units are installed under one hood. The price would increase when several units are installed under one hood.

Internal ID: 1108

M50-18

IMC: 505.3

Proponent: John Williams, Chair, representing Healthcare Committee (AHC@iccsafe.org)

2018 International Mechanical Code

Revise as follows:

505.3 Exhaust ducts. Domestic cooking exhaust equipment shall discharge to the outdoors through sheet metal ducts constructed of galvanized steel, stainless steel, aluminum or copper. Such ducts shall have smooth inner walls, shall be air tight, shall be equipped with a backdraft damper, and shall be independent of all other exhaust systems. Installations in Group I-1 and I-2 occupancies shall be in accordance with the International Building Code and Section 904.13 of the International Fire Code.

Exceptions:

1. ~~In other than Groups I-1 and I-2, where~~ Where installed in accordance with the manufacturer's instructions and where mechanical or natural ventilation is otherwise provided in accordance with Chapter 4, listed and labeled ductless range hoods shall not be required to discharge to the outdoors.
2. Ducts for domestic kitchen cooking appliances equipped with downdraft exhaust systems shall be permitted to be constructed of Schedule 40 PVC pipe and fittings provided that the installation complies with all of the following:
 - 2.1. The duct shall be installed under a concrete slab poured on grade.
 - 2.2. The underfloor trench in which the duct is installed shall be completely backfilled with sand or gravel.
 - 2.3. The PVC duct shall extend not more than 1 inch (25 mm) above the indoor concrete floor surface.
 - 2.4. The PVC duct shall extend not more than 1 inch (25 mm) above grade outside of the building.
 - 2.5. The PVC ducts shall be solvent cemented.

Reason:

In Section 505.3, Exception #1 language was incorrectly added that would prohibit Group I-1 and I-2 occupancies from having recirculating hoods. As long as proper mechanical or natural ventilation is provided, the hood is installed per manufacturer's instructions, and it meets the ventilation requirements, there is no justification on why these hoods cannot be re-circulating.

This proposal is submitted by the ICC Committee on Healthcare (CHC). The CHC was established by the ICC Board to evaluate and assess contemporary code issues relating to healthcare facilities. This is a joint effort between ICC and the American Society for Healthcare Engineering (ASHE), a subsidiary of the American Hospital Association, to eliminate duplication and conflicts in healthcare regulation. In 2017 the CHC held 2 open meetings and numerous conference calls, which included members of the committees as well as any interested parties, to discuss and debate the proposed changes. Information on the CHC, including: meeting agendas; minutes; reports; resource documents; presentations; and all other materials developed in conjunction with the CHC effort can be downloaded from the CHC website at: <https://www.iccsafe.org/codes-tech-support/cs/icc-committee-on-healthcare/>.

Cost Impact

The code change proposal will decrease the cost of construction .

This exception where permitted in Groups I-1 and I-2 could result in a reduction of shaft and duct requirements to vent the hood to the outside, possibly through several floors.

Internal ID: 1306

M51-18

IMC: 505.3, 505.7 (New)

Proponent: John Williams, Chair, representing Healthcare Committee (AHC@iccsafe.org)

2018 International Mechanical Code

Revise as follows:

505.3 Exhaust ducts. Domestic cooking exhaust equipment shall discharge to the outdoors through sheet metal ducts constructed of galvanized steel, stainless steel, aluminum or copper. Such ducts shall have smooth inner walls, shall be air tight, shall be equipped with a backdraft damper, and shall be independent of all other exhaust systems. ~~Installations in Group I-1 and I-2 occupancies shall be in accordance with the International Building Code and Section 904.13 of the International Fire Code.~~

Exceptions:

1. In other than Groups I-1 and I-2, where installed in accordance with the manufacturer's instructions and where mechanical or natural ventilation is otherwise provided in accordance with Chapter 4, listed and labeled ductless range hoods shall not be required to discharge to the outdoors.
2. Ducts for domestic kitchen cooking appliances equipped with downdraft exhaust systems shall be permitted to be constructed of Schedule 40 PVC pipe and fittings provided that the installation complies with all of the following:
 - 2.1. The duct shall be installed under a concrete slab poured on grade.
 - 2.2. The underfloor trench in which the duct is installed shall be completely backfilled with sand or gravel.
 - 2.3. The PVC duct shall extend not more than 1 inch (25 mm) above the indoor concrete floor surface.
 - 2.4. The PVC duct shall extend not more than 1 inch (25 mm) above grade outside of the building.
 - 2.5. The PVC ducts shall be solvent cemented.

Add new text as follows:

505.7 Domestic cooking systems. Cooktops and ranges installed in the following occupancies shall be protected in accordance with Section 904.13.1 of the International Fire Code.

1. In Group I-1 occupancies where domestic cooking facilities are installed in accordance with Section 420.8 of the International Building Code.
2. In Group I-2, Condition 1 occupancies where domestic cooking facilities are installed in accordance with Section 407.2.6 of the International Building Code.
3. In Group R-2 college dormitories where domestic cooking facilities are installed in accordance with Section 420.10 of the International Building Code.

Reason:

M45-15 as modified created the last sentence to IMC Section 505.3. The last sentence in 505.3 is an incorrect and circular reference. There are no exhaust hood requirements in IBC 407 or 410 (Group I-2 and I-1 respectively) - those sections send you to IMC for exhaust hood. The intent seems to be more as a reference to the protection in the hood in IFC Section 904.13. See new Section 505.7 for a better reference that is a copy of text already in IFC 904.13. Our intent is that if the other proposals related to domestic cooking in Group I-1 and I-2 are accepted that the references would be coordinated in the IMC and IFC.

This proposal is submitted by the ICC Committee on Healthcare (CHC). The CHC was established by the ICC Board to evaluate and assess contemporary code issues relating to healthcare facilities. This is a joint effort between ICC and the American Society for Healthcare Engineering (ASHE), a subsidiary of the American Hospital Association, to eliminate duplication and conflicts in healthcare regulation. In 2017 the CHC held 2 open meetings and numerous conference calls, which included members of the committees as well as any interested parties, to discuss and debate the proposed changes. Information on the CHC, including: meeting agendas; minutes; reports; resource documents; presentations; and all other materials developed in conjunction with the CHC effort can be downloaded from the CHC

website at: <https://www.iccsafe.org/codes-tech-support/cs/icc-committee-on-healthcare/>.

Cost Impact

The code change proposal will not increase or decrease the cost of construction .

This is an editorial correction of references.

Internal ID: 1304

M52-18

IMC: 506.5.2, 15

Proponent: Jonathan Roberts, UL LLC, representing UL LLC (jonathan.roberts@ul.com)

2018 International Mechanical Code

Revise as follows:

506.5.2 Pollution-control units. The installation of pollution-control units shall be in accordance with the manufacturer's installation instructions and all of the following:

1. Pollution-control units shall be listed and labeled in accordance with UL ~~1978-8782~~.
2. Fans serving pollution-control units shall be listed and labeled in accordance with UL 762.
3. ~~Pollution~~Bracing and supports for pollution-control units shall be ~~mounted and secured in accordance with the manufacturer's installation instructions and~~ of noncombustible material securely attached to the structure and designed to carry gravity and seismic loads within the stress limitations of the International Building Code.
4. Pollution-control units located indoors shall be listed and labeled for such use. Where enclosed duct systems, as required by Section 506.3.11, are connected to a pollution control unit, such unit shall be ~~located in a room or space listed and labeled, in accordance with UL 2221 or ASTM E2336, for location in an enclosure~~ having the same fire-resistance rating as the duct enclosure. Access shall be provided for servicing and cleaning of the unit. The space or enclosure shall be ventilated in accordance with the manufacturer's installation instructions.
5. ~~A clearance of not less than 18 inches (457 mm)~~ Clearances shall be maintained between the pollution-control unit and combustible ~~material~~ material in accordance with the listing.
6. Roof-mounted pollution-control units shall be listed for outdoor installation and shall be mounted not less than 18 inches (457 mm) above the roof.
7. Exhaust outlets for pollution-control units shall be in accordance with Section 506.3.13.
8. An airflow differential pressure control shall be provided to monitor the pressure drop across the filter sections of a pollution-control unit. When the airflow is reduced below the design velocity, the airflow differential pressure control shall activate a visual alarm located in the area where cooking operations occur.
9. Pollution-control units shall be provided with a factory-installed fire suppression system.
10. Service space shall be provided in accordance with the manufacturer's instructions for the pollution control unit and the requirements of Section 306.
11. Wash-down drains shall discharge through a grease interceptor and shall be sized for the flow. Drains, shall be sealed with a trap or other approved means to prevent air bypass. Where a trap is utilized it shall have a seal depth that accounts for the system pressurization and evaporation between cleanings.
12. Protection from freezing shall be provided for the water supply and fire suppression systems where such systems are subject to freezing.
13. Duct connections to pollution-control units shall be in accordance with Section 506.3.2.3. Where water splash or carryover can occur in the transition duct as a result of a washing operation, the transition duct shall slope downward toward the cabinet drain pan for a length not less than 18 inches (457 mm). Ducts shall transition to the full size of the unit's inlet and outlet openings.
14. Extra-heavy-duty appliance exhaust systems shall not be connected to pollution-control units except where such units are specifically designed and listed for use with solid fuels.
15. Pollution-control units shall be maintained in accordance with the manufacturer's instructions.

Add new standard(s) follows:

UL

UL LLC
333 Pfingsten Road
Northbrook IL 60062-2096

8782-17:

Outline of Investigation for Pollution Control Units for Commercial Cooking

Reason:

This proposal further refines the requirements for pollution control units, as follows:

Item 1: UL 1978, the Standard for Grease Ducts, does not contain all the requirements necessary for listing PCUs. UL developed the UL 8782, "Outline of Investigation for Pollution Control Units for Commercial Cooking", in collaboration with code officials, manufacturers, and installers. UL 8782 contains both construction and performance requirements to address various issues not covered by UL 1978, including:

Air filtration components – PCUs use various methods of filtration, such as electrostatic precipitators or grease filters.
Electrical requirements – PCUs are also electrical equipment, for purposes of providing both power and control.

Item 3: Clarifies the requirements for mounting and supporting PCUs. These are the same requirements that are used for supporting grease ducts (IMC Section 506.3.3).

Item 4: Requirements used to evaluate the effectiveness of the combination of a PCU and an enclosure as a fire rated enclosure system and through penetration firestop system, as well as the enclosure's effect on the PCU are contained in UL 2221 and ASTM E2336.

Item 5: UL 8782 contains the same performance criteria as UL 1978 to establish the minimum clearances to combustible material. UL 8782 requires the PCUs to be marked with the minimum clearances.

Cost Impact

The code change proposal will not increase or decrease the cost of construction .

No cost impact. Manufacturers are already testing and certifying their PCUs in accordance with UL 8782. This proposal provides clarity on the requirements for PCUs, as well as additional flexibility.

Analysis: A review of the standard proposed for inclusion in the code, with regard to the ICC criteria for referenced standards (Section 3.6 of CP#28) will be posted on the ICC website on or before April 2, 2018.

Internal ID: 423

M53-18 Part I

IMC: 504.6 (New)

Proponent: Julius Ballanco, JB Engineering and Code Consulting, P.C., representing Systemair (JBEngineer@aol.com)

THIS IS A 2 PART CODE CHANGE PROPOSAL. PART I WILL BE HEARD BY THE IMC COMMITTEE AND PART II WILL BE HEARD BY THE IRC M/P COMMITTEE. PLEASE SEE THE HEARING ORDERS FOR THESE COMMITTEES.

2018 International Mechanical Code

Add new text as follows:

504.6 Booster fans prohibited. Domestic booster fans shall not be installed in dryer exhaust systems.

Internal ID: 1167

M53-18 Part II

IRC: M1502.4.5 (New)

Proponent: Julius Ballanco, JB Engineering and Code Consulting, P.C., representing Systemair (JBEngineer@aol.com)

2018 International Residential Code

Add new text as follows:

M1502.4.5 Booster fans prohibited. Domestic booster fans shall not be installed in dryer exhaust systems.

Reason:

This change is being proposed for clarity to distinguish between old style booster fans and dryer exhaust duct power ventilators (DEDPV). UL 2158 (electric dryer standard) and ANSI Z21.5.1/CSA 7.1 (gas dryer standard) prohibit domestic dryers from connecting to dryer exhaust systems having booster fans. The warning required to be included in the installation instructions by both standards reads, "WARNING: Risk of Fire. Do not install a booster fan in the exhaust duct."

Booster fans were a class of ventilators that were installed before the introduction of dryer exhaust duct power ventilators or DEDPVs. DEDPV are regulated by UL 705, whereas old style booster fans were not specifically addressed in any UL standard. DEDPVs are not impacted by this change since Section 504.5 in the Mechanical Code and Section M1502.4.4 of the Residential Code permit the installation and use of DEDPVs.

Cost Impact

The code change proposal will not increase or decrease the cost of construction .

The change only clarifies current code requirements.

Internal ID: 3416

M54-18

IMC: 506.3.7

Proponent: Keith Page, Hart & Cooley / Selkirk, representing Hart & Cooley / Selkirk - Engineering Manager

2018 International Mechanical Code

Revise as follows:

506.3.7 Prevention of grease accumulation in grease ducts. Duct systems serving a Type I hood shall be constructed and installed so that grease cannot collect in any portion thereof, and the system shall slope not less than one-fourth unit vertical in 12 units horizontal (2-percent slope) toward the hood or toward a grease reservoir designed and installed in accordance with Section 506.3.7.1. Where horizontal ducts exceed 75 feet (22 860 mm) in length, the slope shall be not less than one unit vertical in 12 units horizontal (8.3-percent slope).

Exception: Factory-built grease ducts shall be installed at a slope that is in accordance with the listing and manufacturer's installation instructions.

Reason:

To be in harmony with other code bodies across the country as NFPA and UMC both have this language incorporated. Factory-built manufacturers have been installing to a lesser slope for many years according to their respective testing agency listings.

Cost Impact

The code change proposal will not increase or decrease the cost of construction .

The installation of factory-built grease duct has been installed w/ lesser slope by means of following our UL listed instructions and therefore this code editorial update won't change the current field installation process. In fact, in some instances where there is a very long horizontal run (i.e. exceeding 75'), the lower slope requirement of a UL listed duct mitigates the often used see-saw design of rectangular field fabricated ducts that typically require drains at the bottom of the see-saw, thus requiring maintenance

Internal ID: 1220

M55-18

IMC: 510.4

Proponent: Mark Jelinske, representing Self (mjelinske@rmhgroup.com)

2018 International Mechanical Code

Revise as follows:

510.4 Independent system. Hazardous exhaust systems shall be independent of other types of exhaust systems.

Exception: Environmental air exhaust inlets combined with hazardous exhaust inlets in the same room.

Reason:

In a laboratory with fume hoods, the hoods alone may not provide an adequate ventilation air exchange rate, particularly in a modern lab with Variable Air Volume fume hoods. In this very common case, auxiliary exhaust air inlets are used to maintain the proper air changes.

In some cases, this has been hard to justify where a hard core interpretation is made that "if it isn't a fume hood, it isn't hazardous", and therefore they can't be combined.

In most cases, it is recognized that this is the right way to do it, and a little "dancing" is required to say the absence of the auxiliary exhaust would trigger the conditions of 510.2 and therefore making it a Hazardous Exhaust, while trying to not notice the requirements of 510.6.4 "that contaminants are captured by an airstream at the area where the emissions are generated".

It is recognized that this concept could be overextended by using the Hazardous Exhaust to provide ventilation of support spaces, offices, corridors, etc. not associated with the fume hood. Thus the restriction to room with a fume hood.

Cost Impact

The code change proposal will not increase or decrease the cost of construction .

The intent of this proposal is to clarify a common design practice.

Internal ID: 1477

M56-18

IMC: 510.4 (New), 510.5

Proponent: Mark Jelinske, representing Self (mjelinske@rmhgroup.com)

2018 International Mechanical Code

Add new text as follows:

510.4 Incompatible Materials. Incompatible materials, as defined in the International Fire Code, shall not be exhausted through the same hazardous exhaust system.

Revise as follows:

~~**510.5 Incompatible materials and common shafts.** Incompatible materials, as defined in the International Fire Code, shall not be exhausted through the same hazardous exhaust system. Hazardous exhaust systems shall not share common shafts with other duct systems, except where such systems are hazardous exhaust systems originating in the same fire area.~~

Exception: The provisions of this section shall not apply to laboratory exhaust systems where all of the following conditions apply:

1. All of the hazardous exhaust ductwork and other laboratory exhaust within both the occupied space and the shafts are under negative pressure while in operation.
2. The hazardous exhaust ductwork manifolded together within the occupied space must originate within the same fire area.
3. Hazardous exhaust ductwork originating in different fire areas and manifolded together in a common shaft shall meet the provisions of Section 717.5.3, Exception 1, Item 1.1 of the International Building Code.
4. Each control branch has a flow regulating device.
5. Perchloric acid hoods and connected exhaust shall be prohibited from manifolding.
6. Radioisotope hoods are equipped with filtration, carbon beds or both where required by the *registered design professional*.
7. Biological safety cabinets are filtered.
8. Each hazardous exhaust duct system shall be served by redundant exhaust fans that comply with either of the following:
 - 8.1. The fans shall operate simultaneously in parallel and each fan shall be individually capable of providing the required exhaust rate.
 - 8.2. Each of the redundant fans is controlled so as to operate when the other fan has failed or is shut down for servicing.

Reason:

The provisions for incompatible materials and common shafts should be separated.

Materials that are incompatible do not lose their incompatibility just because the duct system they are being conveyed in meets the exceptions of 510.5.

The provisions for separate shafts, and the exceptions to allow manifolding has to do with maintaining the integrity of the separate fire areas and vertical separations in a system where Smoke or Fire dampers are not allowed

These two concepts are incompatible.

Cost Impact

The code change proposal will not increase or decrease the cost of construction .

This should be a clarification to the original intent. It is unlikely responsible designers are currently combining materials they know to be incompatible in the same duct system.

Internal ID: 1472

M57-18

IMC: 508.1.1

Proponent: Pennie Feehan, representing Plumbing, Mechanical, and Fuel Gas Code Action Committee (PMGCAC@iccsafe.org)

2018 International Mechanical Code

Revise as follows:

508.1.1 Makeup air temperature. ~~The temperature differential between *makeup air* and the air in the conditioned space shall not exceed 10°F (6°C) except where the added heating and cooling loads of the *makeup air* do not exceed the capacity of the HVAC system.~~ HVAC system that serves the kitchen space shall have the additional capacity necessary for the latent and sensible loads that are introduced by the makeup air supplied to the kitchen space, or the makeup air shall be conditioned by dedicated systems such that the difference in temperature between the makeup air supplied to the kitchen space and the design setpoint temperature in the kitchen space is not greater than 10 degrees F (6 degrees C).

Exception: Makeup air supplied to a compensating hood need not be conditioned.

Reason:

This rewrite of the section intends to clarify the intent which was to either design the HVAC system for the kitchen to handle makeup air loads, or to have a dedicated makeup air conditioning system. It is also clarified that the 10 degree differential applies to the thermostat setpoint temperature in the kitchen, not the temperature of the kitchen as it happens to be at any given point in the day. If the HVAC system can handle the loads from makeup air, then the kitchen space temperature will reflect the thermostat setpoint. If a dedicated makeup air system is installed, then it must adhere to the delta 10 degree criterion. The exception recognizes that makeup air fed directly to the integral makeup air plenum of a hood or directly into the mouth of a hood need not be conditioned, since it might not affect the comfort of the employees.

This proposal is submitted by the ICC Plumbing/Mechanical/Gas Code Action Committee (PMG CAC). The PMG CAC was established by the ICC Board of Directors to pursue opportunities to improve and enhance the International Codes or portions thereof that were under the purview of the PMG CAC. In 2017 the PMG CAC held one face-to-face meeting and 11 conference call meetings. Numerous interested parties attended the committee meetings and offered their input.

Cost Impact

The code change proposal will not increase or decrease the cost of construction .

This proposal will not increase the cost of construction because no additional labor, materials, equipment, appliances or devices are mandated beyond what is currently required by the code.

Internal ID: 439

M58-18

IMC: 514.2

Proponent: Pennie Feehan, representing Plumbing, Mechanical, and Fuel Gas Code Action Committee (PMGCAC@iccsafe.org)

2018 International Mechanical Code

Revise as follows:

514.2 Prohibited applications. Energy recovery ventilation systems shall not be used in the following systems:

1. Hazardous exhaust systems covered in Section 510.
2. Dust, stock and refuse systems that convey explosive or flammable vapors, fumes or dust.
3. Smoke control systems covered in Section 513.
4. Commercial kitchen exhaust systems serving Type I ~~or Type II~~ hoods.
5. Clothes dryer exhaust systems covered in Section 504.

Exception: The application of ERV equipment that recovers sensible heat only utilizing coil-type heat exchangers shall not be limited by this section.

Reason:

This revision simply relaxes the prohibition on ERV's for Type II hoods. Type II hoods discharge warm moist air and ERV's can take advantage of the rich source of latent and sensible heat energy. Type II hood exhaust does not contain grease vapors and cooking particulates that could create a hazard with ERV heat exchangers.

This proposal is submitted by the ICC Plumbing/Mechanical/Gas Code Action Committee (PMG CAC). The PMG CAC was established by the ICC Board of Directors to pursue opportunities to improve and enhance the International Codes or portions thereof that were under the purview of the PMG CAC. In 2017 the PMG CAC held one face-to-face meeting and 11 conference call meetings. Numerous interested parties attended the committee meetings and offered their input.

Cost Impact

The code change proposal will not increase or decrease the cost of construction .

This proposal will not increase the cost of construction because no additional labor, materials, equipment, appliances or devices are mandated beyond what is currently required by the code.

Internal ID: 442

M59-18

IMC: 504.4.1 (New)

Proponent: Pennie Feehan, representing Plumbing, Mechanical, and Fuel Gas Code Action Committee (PMGCAC@iccsafe.org)

2018 International Mechanical Code

Add new text as follows:

504.4.1 Termination location. Exhaust duct terminations shall be in accordance with the dryer manufacturer's installation instructions. Where the manufacturer's instructions do not specify a termination location, the exhaust duct shall terminate not less than 3 feet (914 mm) in any direction from openings into buildings including openings in ventilated soffits.

Reason:

Current code does not address clearances between building openings and clothes dryer exhaust terminals. This proposal coordinates with the requirement in the IRC.

This proposal is submitted by the ICC Plumbing/Mechanical/Gas Code Action Committee (PMG CAC). The PMG CAC was established by the ICC Board of Directors to pursue opportunities to improve and enhance the International Codes or portions thereof that were under the purview of the PMG CAC. In 2017 the PMG CAC held one face-to-face meeting and 11 conference call meetings. Numerous interested parties attended the committee meetings and offered their input.

Cost Impact

The code change proposal will not increase or decrease the cost of construction .

This proposal will not increase the cost of construction because no additional labor, materials, equipment, appliances or devices are mandated beyond what is currently required by the code.

Internal ID: 557

M60-18

IMC: 514.2

Proponent: Randall Dahmen, Self, representing Self

2018 International Mechanical Code

514.2 Prohibited applications. Energy recovery ventilation systems shall not be used in the following systems:

1. Hazardous exhaust systems covered in Section 510.
2. Dust, stock and refuse systems that convey explosive or flammable vapors, fumes or dust.
3. Smoke control systems covered in Section 513.
4. Commercial kitchen exhaust systems serving Type I or Type II hoods.
5. Clothes dryer exhaust systems covered in Section 504.

~~Exception~~ Exceptions:

1. The application of ERV equipment that recovers sensible heat only utilizing coil-type heat exchangers shall not be limited by this section.
2. An engineered energy recovery ventilation system shall not be limited by this section provided that corrosion, cross-contamination and fouling are addressed by such engineered system.

Reason:

The incorporation of the proposed language will provide greater opportunities for energy conservation via energy recovery systems. The language reinforces the reasoning in the code as to why certain energy recovery systems should not be used, by providing guidance to systems that meet the intent of the code.

Cost Impact

The code change proposal will not increase or decrease the cost of construction .

The intent of the proposed wording was to provide design flexibility for energy conservation efforts. There is no change to the cost of construction

Internal ID: 1701

M61-18

IMC: 507.5

Proponent: Randall Dahmen, Self, representing Self

2018 International Mechanical Code

Revise as follows:

507.5 Capacity of hoods. Commercial food service hoods shall exhaust a minimum net quantity of air determined in accordance with this section and Sections 507.5.1 through 507.5.5 or as determined by engineering analysis. The net quantity of *exhaust air* shall be calculated by subtracting any airflow supplied directly to a hood cavity from the total exhaust flow rate of a hood. Where any combination of *heavy-duty*, *medium-duty* and *light-duty cooking appliances* are utilized under a single hood, the exhaust rate required by this section for the heaviest duty *appliance* covered by the hood shall be used for the entire hood.

Reason:

The current code language provides no flexibility for reducing the minimum exhaust rate for the various listed hoods. The intent of this proposed language change is to allow for the use of reduced exhaust rates if it can be demonstrated to the code official that a reduced exhaust rate would be acceptable for the proposed use. In general, exhaust rates for kitchen hoods are dependent on the type of food cooked, the amount of grease vapor or smoke produced, the temperature(s) of the cooking appliance or cooking oils, etc.

The intent is provide an opportunity to reduce the minimum exhaust rate, and thereby increase energy savings since the exhaust fan will not be required to operate at the current mandated exhaust rates. Additionally, in those cooler regions, adoption of this proposed language will require less tempered make-up air to be brought into the building for air balancing purposes as is required by IMC 508.

Cost Impact

The code change proposal will decrease the cost of construction .

Although an exhaust fan is required for all commercial kitchen hoods, the size of the exhaust fan may be able to be decreased due to a reduced minimum exhaust flow rate, assuming adequate justification has been provided to the code official.

Internal ID: 1696

M62-18

IMC: SECTION 511, 511.1, 511.1.1, 511.1.5

Proponent: Robert Davidson, Davidson Code Concepts, LLC, representing Self (rjd@davidsoncodeconcepts.com)

2018 International Mechanical Code

SECTION 511 DUST, STOCK AND REFUSE CONVEYING SYSTEMS

Revise as follows:

511.1 Dust, stock and refuse conveying systems. Dust, stock and refuse conveying systems shall comply with the provisions of Section 510 and Sections 511.1.1 through 511.2 and the International Fire Code.

511.1.1 Collectors and separators. Collectors and separators involving such systems as centrifugal separators, bag filter systems and similar devices, and associated supports shall be constructed of noncombustible materials and shall be located on the exterior of the building or structure. A collector or separator shall not be located nearer than 10 feet (3048 mm) to combustible construction or to an unprotected wall or floor opening, unless the collector is provided with a metal vent pipe that extends above the highest part of any roof with a distance of 30 feet (9144 mm).

Exceptions:

1. Collectors such as "Point of Use" collectors, close extraction weld fume collectors, spray finishing booths, stationary grinding tables, sanding booths, and integrated or machine-mounted collectors shall be permitted to be installed indoors provided that the installation is in accordance with the International Fire Code and NFPA 70.
2. Collectors in independent exhaust systems handling combustible dusts shall be permitted to be installed indoors provided that such collectors are installed in compliance with the International Fire Code and NFPA 70.

511.1.5 Explosion relief vents-control. ~~A safety or explosion relief vent~~ Explosion control shall be provided in accordance with the requirements of the International Fire Code on all systems that convey combustible refuse or stock ~~of an explosive nature, that produce combustible dusts in such a manner that the concentration and conditions create a fire or explosion hazard based on a Dust Hazard Analysis prepared in accordance with the requirements~~ Section 2203.2 of the International Building Fire Code.

Reason:

This proposal is follow up work correlating the IBC, IMC and IFC provisions with the work done on Chapter 22 Combustible Dust and Chapter 37 Combustible Fibers in the IFC along with Section 426 of the IBC. Last cycle IBC Section 426 and Chapter 22 Combustible Dust-Producing Operations were updated to apply the new NFPA 652 Standard on the Fundamentals of Combustible Dust as the lead document when identifying and managing combustible dust hazards.

In this proposal Section 511.1 has been modified to add "and the International Fire Code" in the top scoping section. In looking at 511.1 and the following sections the IFC would only apply for the exceptions to Section 511.1.1 when it should apply generally regardless of whether or not a system is located inside or on th exterior of a facility.

Section 511.1.5 is modified to rename it 'Explosion Control" which is the correct terminology, the necessary protection features are much more than just "relief vents". "Explosion control" has been inserted as the lead requirement to be applied with linkage to the IFC as the correct document for installing explosion control. In addition language has been added "that produce combustible dusts in such a manner that the concentration and conditions create a fire or explosion hazard based on a Dust Hazard Analysis prepared" which is a phrase being applied and updated in other areas of the codes foor the required assessment of the potential hazard. Finally, the pointer to Section 2203.2 of the IFC leads the designer and the code official to the linkage with NFPA 652.

Cost Impact

The code change proposal will not increase or decrease the cost of construction .

Updating the language to correlate with other changes in the codes is not expected to increase or decrease the cost of construction, however, increasing clarification in code application provides an opportunity to reduce costs.

Internal ID: 1624

M63-18

IMC: 602.2, 603.5.1

Proponent: Brent Ursenbach, Salt Lake County Planning and Development Services, representing Salt Lake County Planning and Development Services (bursenbach@slco.org)

2018 International Mechanical Code

Revise as follows:

602.2 Construction. *Plenum* enclosure construction materials that are exposed to the airflow shall comply with the requirements of Section 703.5 of the International Building Code or such materials shall have a flame spread index of not more than 25 and a smoke-developed index of not more than 50 when tested in accordance with ASTM E84 or UL 723.

The use of gypsum boards to form plenums shall be limited to systems where the air temperatures do not exceed 125°F (52°C) and the building and mechanical system design conditions are such that the gypsum board surface temperature will be maintained above the airstream dew-point temperature. ~~Air-Supply air~~ plenums formed by gypsum boards shall not be incorporated in air-handling systems utilizing direct evaporative ~~coolers-cooling systems~~.

603.5.1 Gypsum ducts. The use of gypsum boards to form air shafts (ducts) shall be limited to return air systems where the air temperatures do not exceed 125°F (52°C) and the gypsum board surface temperature is maintained above the airstream dew-point temperature. ~~Air-Supply air~~ ducts formed by gypsum boards shall not be incorporated in air-handling systems utilizing direct evaporative ~~coolers-cooling systems~~.

Reason:

This code sentence as written, may be interpreted to prohibit the use of a gypsum board plenum in any building using any form of evaporative cooling. It also prohibits the use of individual or combination direct and indirect evaporative cooling systems where the supply air system is ducted. The proponent assumes the intent is to prevent a condition where the gypsum board in a plenum is exposed to air with a potentially high relative humidity.

This proposed code change continues to prohibits direct evaporatively cooled air from being discharged into a gypsum board supply air plenum, while allowing this extremely effective and efficient cooling option, with a gypsum board return air plenum.

Direct and indirect evaporative cooling systems use only a fraction of the energy used by direct expansion cooling systems. These systems are very effect and commonly used in buildings of virtually all uses and occupancies in dry climates. Cooling towers, a form of indirect evaporative cooling are used in all climates.

Please see ASHRAE Handbook - HVAC Systems and Equipment, Chapter 41, for a detailed discussion on Evaporative Air-Cooling Equipment

For clarity, the following definitions have been proposed this code cycle:

Direct Evaporative Cooling- The evaporative cooling process where water evaporates directly into the air stream, reducing the air's dry-bulb temperature and raising its humidity level.

Indirect Evaporative Cooling-The evaporative cooling process where water evaporates into a secondary air stream, removing heat from a primary air stream using a heat exchanger.

Cost Impact

The code change proposal will decrease the cost of construction .

In dry climates, direct and indirect evaporative cooling systems often provide up to 75% of the required cooling capacity, allowing the DX cooling system sizing to be similarly reduced. This decreases the initial cost of construction, while reducing the operating cost over the life of the systems.

Internal ID: 1473

M64-18

IMC: 601.5

Proponent: Brent Ursenbach, representing Salt Lake County Planning and Development Services
(bursenbach@slco.org)

2018 International Mechanical Code

601.5 Return air openings. Return air openings for heating, ventilation and air-conditioning systems shall comply with all of the following:

1. Openings shall not be located less than 10 feet (3048 mm) measured in any direction from an open combustion chamber or draft hood of another appliance located in the same room or space.
2. Return air shall not be taken from a hazardous or insanitary location or a refrigeration room as defined in this code.
3. The amount of return air taken from any room or space shall be not greater than the flow rate of supply air delivered to such room or space.
4. Return and transfer openings shall be sized in accordance with the appliance or equipment manufacturer's installation instructions, ACCA Manual D or the design of the registered design professional.
5. Return air taken from one dwelling unit shall not be discharged into another dwelling unit.
6. Taking return air from a crawl space shall not be accomplished through a direct connection to the return side of a forced air furnace. Transfer openings in the crawl space enclosure shall not be prohibited.
7. Return air shall not be taken from a closet, bathroom, toilet room, kitchen, garage, boiler room, furnace room or unconditioned attic.
8. Return air shall not be taken from indoor swimming pool enclosures and associated deck areas.

Exceptions:

1. Where the air from such spaces is dehumidified in accordance with Section 403.2.1, Item 2.
2. Dedicated HVAC systems serving only such spaces.

Exceptions:

1. Taking return air from a kitchen is not prohibited where such return air openings serve the kitchen and are located not less than 10 feet (3048 mm) from the cooking appliances.
2. Taking return air from a kitchen is not prohibited in a dwelling unit where the kitchen and living spaces are in a single room and the cooking appliance is electric and located not less than 5 feet in any direction from the return air intake opening.
- ~~2-3.~~ Dedicated forced air systems serving only the garage shall not be prohibited from obtaining return air from the garage.

Reason:

There is an increasing trend towards smaller living spaces, including studio apartment, extended stay hotels, small homes and even tiny homes. Where the cooking appliance and living space are combined in a single space, requiring 10' between to return air inlet and the small cooking appliance serves no purpose. Cooking odors, even from burned food, will spread throughout the room, no matter how far the return is located from the appliance.

As some may be concerned with air-flow towards a return inlet impacting the flame of a gas burner, this exception is limited to electric appliances.

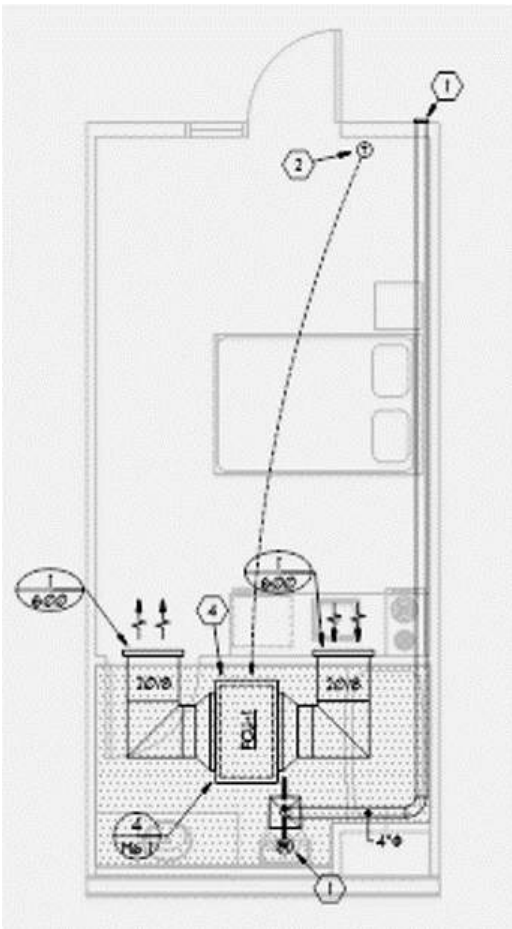
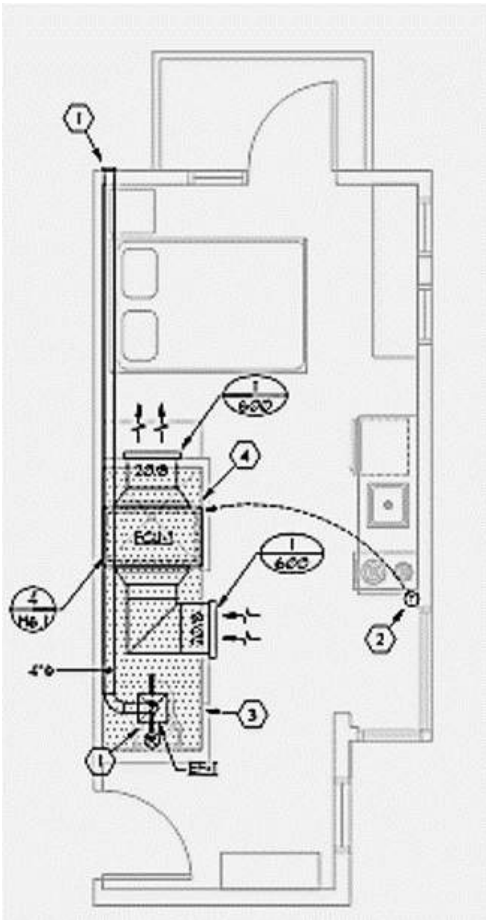

Cost Impact

The code change proposal will decrease the cost of construction .

This proposal will in some cases, reduce the length of return air duct required, reduce duct ceiling drops, resulting in a material and labor savings.

Internal ID: 1475

M65-18

IMC: 602.2.1.7

Proponent: Brian Helms, Charlotte Pipe and Foundry, Plastics Division, representing Charlotte Pipe and Foundry (brian.helms@charlottepipe.com)

2018 International Mechanical Code

Revise as follows:

602.2.1.7 Plastic plumbing piping and tubing. Plastic piping and tubing used in plumbing systems shall be listed and labeled as having a flame spread index not greater than 25 and a smoke-developed index not greater than 50 when tested in accordance with ASTM E84 or UL 723.

~~**Exception:** Plastic water distribution piping and tubing listed and labeled in accordance with UL 2846 as having a peak optical density not greater than 0.50, an average optical density not greater than 0.15, and a flame spread distance not greater than 5 feet (1524 mm), and installed in accordance with its listing.~~

Reason:

Most officials and members do not realize that the allowable smoke developed criteria included in the 602.2.1.7 exception for the UL 2846 test protocol is approximately 2.5 times higher than the traditional limit of 50 that the code requires for ASTM E 84 or UL 723 tests. Charlotte Pipe conducted UL 2846 tests at Underwriters Laboratories. Our testing found the requirements of the UL 2846 exception to be less restrictive than the E 84 protocol. For example, we tested two 3/4" CPVC pipes to the ASTM E 84 protocol and they failed the requirements of the code with a smoke developed index of 115, while two identical 3/4" pipes passed the requirements of the UL 2846 test exception in the same lab, with an average optical density of .05. Currently, the 602.2.1.7 exception allows an average optical density up to .15.

This exception was passed during the last cycle with no data to support such a huge increase in the allowable limit for smoke development. While the UL 2846 may be a reasonably good test for plastic piping, the requirements of the exception should have been developed relative to the E 84 and UL 723 flame spread and smoke developed criteria for each product type before being added to the codes. By allowing the requirements of the 602.2.1.7 exception to remain in the code we are allowing products that could produce almost three times the amount of smoke in plenum areas. This exception circumvents the requirements of the code which exist to preserve the health and safety of the public and should be stricken.

Cost Impact

The code change proposal will not increase or decrease the cost of construction .

This code change proposal will not increase or decrease the cost of construction and is intended to clarify existing language by identifying and prohibiting testing practices that circumvent the code requirements

Internal ID: 1906

M66-18

IMC: 602.2.1.7

Proponent: Brian Helms, Charlotte Pipe and Foundry, Plastics Division, representing Charlotte Pipe and Foundry (brian.helms@charlottepipe.com)

2018 International Mechanical Code

Revise as follows:

602.2.1.7 Plastic plumbing piping and tubing. Plastic piping and tubing used in plumbing systems shall be listed and labeled as having a flame spread index not greater than 25 and a smoke-developed index not greater than 50 when tested in accordance with all requirements of ASTM E84 or UL 723. Mounting methods, supports and test specimen dimensions that are not specified in ASTM E 84 or UL 723 shall be prohibited.

~~**Exception:** Plastic water distribution piping and tubing listed and labeled in accordance with UL 2846 as having a peak optical density not greater than 0.50, an average optical density not greater than 0.15, and a flame spread distance not greater than 5 feet (1524 mm), and installed in accordance with its listing.~~

Reason:

A growing issue in the plumbing industry is that the ATSM E 84 test protocol is being modified to test combustible piping materials. At the direction of plastics manufacturers, test labs will modify mounting methods, supports and test specimen dimensions to achieve results that are in compliance with the 25/50 benchmarks the code requires. These results are then used to secure a listing by third party certifiers to serve as proof to code officials of compliance to the flame spread and smoke developed index requirements found in the code.

The question of whether a piping material is in compliance to the flame spread and smoke developed requirements of the code is often further blurred as third party certifiers provide listings indicating that materials meet the 25/50 requirements using modified test methods. Third party certifiers disclose this information in their full listing or report, but this is not always easily identified or even accessible to officials. An inspector seeing ASTM E 84 on a pipe would likely assume that it meets the requirement of the code without fully knowing or understanding the restrictions that exist in the listing. In fact, listing agencies assume that the inspector will analyze the listing and make their own determination on compliance. This code change proposal provides notice to the official that simply adding the ASTM E 84 or UL 723 marking to the wall of the pipe does not necessarily mean that the product was tested in full compliance with the standard in the manner that the code intends.

Charlotte Pipe has conducted ASTM E 84 tests at two different test facilities and found that results below the 25/50 flame spread and smoke developed index are not achievable when performed to the full requirements of ASTM E 84. Our testing has shown that CPVC and PVC piping will not pass the ASTM E 84 without modification of the mounting method, supports or test specimen dimensions.

If the practice of accepting modified test results is allowed to continue, then the requirements of the code will not be achieved. ASTM E 84 is a comparison test, and the 25/50 flame spread and smoke developed index is not a requirement of the standard, but of the code itself. If the 25/50 requirement is too restrictive, then an effort should be made to change the code. If the ASTM E 84 test method is flawed, change the standard. However, we can no longer allow the use of modified tests and third party listings to circumvent the requirements of the code which exist to preserve the health and safety of the public.

Most officials and members do not realize that the allowable smoke developed criteria included in the 602.2.1.7 exception for the UL 2846 test protocol is approximately 2.5 times higher than the traditional limit of 50 that the code requires for ASTM E 84 or UL 723 tests. In addition to ASTM E 84 testing, Charlotte Pipe conducted UL 2846 tests at Underwriters Laboratories. Our testing found the requirements of the UL 2846 exception to be less restrictive than the E 84 protocol. For example, we tested two 3/4" CPVC pipes to the ASTM E 84 protocol and they failed the requirements of the code with a smoke developed index of 115, while two identical 3/4" pipes passed the requirements of the UL 2846 test exception in the same lab, with an average optical density of .05. This exception currently allows an average optical density of up to .15.

This exception was passed during the last cycle with no data to support such a huge increase in the allowable limit for smoke development. While the UL 2846 may be a reasonably good test for plastic piping, the requirements of the exception should have been developed relative to the E 84 and UL 723 flame spread and smoke developed criteria for each product type before being added to the codes. By allowing the requirements of the 602.2.1.7 exception to remain in the code we are allowing products that could produce almost three times the amount of smoke in plenum areas.

This exception should be stricken from the code.

Cost Impact

The code change proposal will not increase or decrease the cost of construction .

This code change proposal will not increase or decrease the cost of construction and is intended to clarify existing language by identifying and prohibiting testing practices that circumvent the code requirements.

Internal ID: 1862

M67-18

IMC: 602.2.1.7

Proponent: Brian Helms, Charlotte Pipe and Foundry, Plastics Division, representing Charlotte Pipe and Foundry (brian.helms@charlottepipe.com)

2018 International Mechanical Code

Revise as follows:

602.2.1.7 Plastic plumbing piping and tubing. Plastic piping and tubing used in plumbing systems shall be listed and labeled as having a flame spread index not greater than 25 and a smoke-developed index not greater than 50 when tested in accordance with all requirements of ASTM E84 or UL 723. Mounting methods, supports and test specimen dimensions that are not specified in ASTM E84 or UL 723 shall be prohibited.

Exception: Plastic water distribution piping and tubing listed and labeled in accordance with UL 2846 as having a peak optical density not greater than 0.50, an average optical density not greater than 0.15, and a flame spread distance not greater than 5 feet (1524 mm), and installed in accordance with its listing.

Reason:

A growing issue in the plumbing industry is that the ASTM E 84 test protocol is being modified to test combustible piping materials. At the direction of plastics manufacturers, test labs will modify mounting methods, supports and test specimen dimensions to achieve results that are in compliance with the 25/50 benchmarks the code requires. These results are then used to secure a listing by third party certifiers to serve as proof to code officials of compliance to the flame spread and smoke developed index requirements found in the code.

The question of whether a piping material is in compliance to the flame spread and smoke developed requirements of the code is often further blurred as third party certifiers provide listings indicating that materials meet the 25/50 requirements using modified test methods. Third party certifiers disclose this information in their full listing or report, but this is not always easily identified or even accessible to officials. An inspector seeing ASTM E 84 on a pipe would likely assume that it meets the requirement of the code without fully knowing or understanding the restrictions that exist in the listing. In fact, listing agencies assume that the inspector will analyze the listing and make their own determination on compliance. This code change proposal provides notice to the official that simply adding the ASTM E 84 or UL 723 marking to the wall of the pipe does not necessarily mean that the product was tested in full compliance with the standard in the manner that the code intends.

Charlotte Pipe has conducted ASTM E 84 tests at two different test facilities and found that results below the 25/50 flame spread and smoke developed index are not achievable when performed to the full requirements of ASTM E 84. Our testing has shown that CPVC and PVC piping will not pass the ASTM E 84 without modification of the mounting method, supports or test specimen dimensions.

If the practice of accepting modified test results is allowed to continue, then the requirements of the code will not be achieved. ASTM E 84 is a comparison test, and the 25/50 flame spread and smoke developed index is not a requirement of the standard, but of the code itself. If the 25/50 requirement is too restrictive, then an effort should be made to change the code. If the ASTM E 84 test method is flawed, change the standard. However, we can no longer allow the use of modified tests and third party listings to circumvent the requirements of the code which exist to preserve the health and safety of the public.

Cost Impact

The code change proposal will not increase or decrease the cost of construction .

This code change proposal will not increase or decrease the cost of construction and is intended to clarify existing language by identifying and prohibiting testing practices that circumvent the code requirements

Internal ID: 1848

M68-18

IMC: 603.8, 603.8.3

Proponent: Charles Stock, Spunstrand Inc, representing Spunstrand Inc

2018 International Mechanical Code

Revise as follows:

603.8 Underground ducts. Ducts shall be *approved* for underground installation and shall be in compliance with Section 603.4 or 603.5. Metallic ducts not having an *approved* protective coating shall be completely encased in not less than 2 inches (51 mm) of concrete.

603.8.3 Plastic ducts and fittings. Plastic ducts shall be constructed of PVC ~~having a~~ that carries a recognized cell classification designation per ASTM D1248 or ASTM D1784 and shall have a minimum pipe stiffness of 8 psi (55 kPa) at 5-percent deflection when tested in accordance with ASTM D2412. Plastic duct fittings shall be constructed of either PVC or high-density polyethylene and shall be in compliance with SMACNA Thermoplastic (PVC) Construction Standards. Plastic duct and fittings shall be utilized in underground installations only. The maximum design temperature for systems utilizing plastic duct and fittings shall be ~~150°F-125°F (66°C-52°C).~~

Reason:

The additions made to 603.8 are intended to clarify that underground duct work, regardless of the material used, shall still comply with the other requirements for metallic or non-metallic duct work as outlined in 603.4 and 603.5. Furthermore, the additions made to 603.8.3 are intended to supply a much needed and missing definition or standard around what is considered allowable plastic duct construction. These additions are needed to insure a consistent and trusted outcome from utilizing "plastic duct work". Lastly, the temperature change from 150F down to 125F is needed to avoid concerns with potential heat distortion issues of plastic duct when used in conjunction with modern heating units capable of higher output air temperatures.

Cost Impact

The code change proposal will not increase or decrease the cost of construction .

There is no expected cost impact due to the proposed changes as it is simply adding much needed clarifications and further details to products, standards, and terms existing in the code.

Analysis: A review of the standard proposed for inclusion in the code, with regard to the ICC criteria for referenced standards (Section 3.6 of CP#28) will be posted on the ICC website on or before April 2, 2018.

Internal ID: 1437

M69-18

IMC: 603.5

Proponent: Charles Stock, Spunstrand Inc, representing Spunstrand Inc

2018 International Mechanical Code

Revise as follows:

603.5 Nonmetallic ducts. Nonmetallic ducts shall be constructed with Class 0 or Class 1 duct material and shall comply with UL 181. Fibrous duct construction shall conform to the SMACNA Fibrous Glass Duct Construction Standards or NAIMA Fibrous Glass Duct Construction Standards. Plastic duct construction shall conform to the SMACNA Thermoplastic Duct (PVC) Construction Standards. Phenolic duct construction shall conform to the SMACNA Phenolic Duct Construction Standards. Fiberglass duct shall conform to the SMACNA Thermoset FRP Duct Construction Standards. The air temperature within nonmetallic ducts shall not exceed 250°F (121°C).

Reason:

Section 301 requires the listing and labeling of almost all installed products in a mechanical system. These listings/labels are to show compliance then with specific standards outlined in the products respective sections. Section 603 has recognized and trusted construction standards for metal duct and fibrous duct, but does not for a handful of other materials often used for air duct. The additions in this proposal are intended to supply the needed and missing material specific product/construction standards for these other duct construction materials.

Cost Impact

The code change proposal will not increase or decrease the cost of construction .

No cost impact is expected as this simply adds needed clarification to the code.

Analysis: A review of the standard proposed for inclusion in the code, with regard to the ICC criteria for referenced standards (Section 3.6 of CP#28) will be posted on the ICC website on or before April 2, 2018.

Internal ID: 1435

M70-18

IMC: 603.2, ordinal

Proponent: David Bixby, Air Conditioning Contractors of America (ACCA), representing Air Conditioning Contractors of America (bixster1953@yahoo.com)

2018 International Mechanical Code

Revise as follows:

603.2 Duct sizing. Ducts installed within a single dwelling unit shall be sized in accordance with ACCA Manual D, the appliance manufacturer's installation instructions or other approved methods; Zoned duct systems shall also comply with ACCA Manual Zr. Ducts installed within all other buildings shall be sized in accordance with the *ASHRAE Handbook of Fundamentals* or other equivalent computation procedure.

Add new standard(s) follows:

ACCA

Air Conditioning Contractors of
America
2800 Shirlington Road, Suite 300
Arlington VA 22206

ANSI/ACCA 11 Manual Zr - 2018:

Residential HVAC System Zoning

Reason:

Currently there is no coverage in the mechanical code to address the design of zoned duct systems. ACCA Manual Zr provides procedures for designing zoned comfort systems for single family detached homes, duplex and triplex homes, row houses, town houses, and large multi-family structures that are compatible with ACCA Manual J procedures for residential load calculations. In addition, use of Manual Zr will avoid the potential for an improperly designed zoned duct system to adversely impact the safe operation and durability of the heating/cooling equipment. For code officials, Manual Zr has three normative sections to determine clear compliance. Manual Zr is also a consensus-based ANSI standard. A proposal to add ACCA Manual Zr to Chapter 15, Referenced Standards, has also been submitted.

Cost Impact

The code change proposal will not increase or decrease the cost of construction .

Cost impacts for using Manual Zr would be minimal, other than some extra time involved. Installers will have to ensure the installation of equipment and zoning devices complies with OEM installation instructions, as well as documenting such. Code officials will have to verify and document airflow rates, set-points for operation and safety controls, which will involve minimal time.

Internal ID: 1870

M71-18

IMC: 602.2.1.8

Proponent: Jay Peters, Codes and Standards International, representing The Copper Development Association (peters.jay@me.com)

2018 International Mechanical Code

Revise as follows:

602.2.1.8 Pipe and duct insulation within plenums. Pipe and duct insulation contained within plenums, including insulation adhesives, shall have a flame spread index of not more than 25 and a smoke developed index of not more than 50 when tested in accordance with ASTM E84 or UL 723, using the specimen preparation and mounting procedures of ASTM E2231. Pipe and duct insulation shall not flame, glow, smolder or smoke when tested in accordance with ASTM C411 at the temperature to which they are exposed in service. The test temperature shall not fall below 250°F(121°C). Pipe and duct insulation shall be listed and labeled. Pipe and duct insulation shall not be used to reduce the maximum flame spread and smoke-developed indexes specified in Section 602.2.1.7 except where tested as a composite assembly of the pipe, tubing, insulation, coatings and adhesives in accordance with ASTM E84 or UL 723.

Reason:

Fire walls, partitions, and similar protective assemblies are tested as composite assemblies, not as individual components. It is critical to have the best understanding possible of how an installed system will perform in the field which equates to replicating those conditions, especially in a plenum. This proposal clarifies that when materials do not meet minimum plenum safety requirements, simply covering them with plenum rated insulation may not be adequate protection, depending on the properties of the material being protected. Some insulation manufacturers market insulation materials for plenums, utilizing a "modified" E84 test, yet the code does not have provisions to use modified tests. Although there are insulation products that meet the flame and smoke requirements for plenums, the materials wrapped within them may begin to degrade, deteriorate and off-gas toxic fumes and substances into plenum spaces due to the high heat, even when protected. This off-gas could result in potential health and life-safety issues for occupants and first responders. All materials within plenums must meet the minimum plenum criteria and the code specifically identifies the proper tests. The IMC does not currently allow for "modified" test procedures in plenums.

Cost Impact

The code change proposal will not increase or decrease the cost of construction .

This proposal clarifies that installations must meet the existing code provisions.

Internal ID: 1343

M72-18

IMC 607.4 (IBC 717.4)

Proponent: Joseph Sandman, representing self (josephs@fioptics.com)

THIS CODE CHANGE PROPOSAL HAS BEEN PLACED ON THE IBC-FS AGENDA. PLEASE SEE THE IBC-FS HEARING ORDER.

2018 International Mechanical Code

Revise as follows:

[BF] 607.4 Access and identification. Fire and smoke dampers shall be provided with an *approved* means of access, ~~large enough~~ to permit inspection and maintenance of the damper and its operating parts. Dampers equipped with fusible links, internal operators, or both shall be provided with an access door that is not less than 12 inches (305mm) square or provided with a removable duct section. The access shall not affect the integrity of fire-resistance-rated assemblies. The access openings shall not reduce the fire-resistance rating of the assembly. Access points shall be permanently identified on the exterior by a label having letters not less than 0.5 inch (12.7 mm) in height reading: FIRE/SMOKE DAMPER, SMOKE DAMPER or FIRE DAMPER. Access doors in ducts shall be tight fitting and suitable for the required duct construction.

Reason:

Fire and smoke dampers are an important part of a HVAC ductwork system, in the event of a fire they are designed to close and prevent the spread of fire and smoke throughout the building duct work system, giving the building occupants enough time to evacuate and also providing the fire department sufficient time to enter the building and extinguish the fire safely.

The NFPA requires all fire and smoke dampers be periodically inspected, maintained and tested per their guidelines to assure these dampers function properly in the event of a fire.

The NFPA requires that fire and smoke dampers are inspected and maintained through an access door that provides full unobstructed access to these dampers. These access doors are mounted on the ductwork as close as possible to the damper. Access doors work well for large fire and smoke dampers because the ductwork size is large enough to except an adequate sized access door, the problem is with the smaller fire and smoke dampers, the ductwork is too small to mount an adequate size access door. NFPA 80 addresses this problem by mandating the minimum size access door shall be no smaller than 12 inch square or you must supply a removable ductwork section, this removable section provides the technician performing the inspection with the unobstructed access needed to properly inspect and maintain the smaller fire and smoke dampers.

Our concerns are with the smaller fire and smoke dampers, because in many cases the removable ductwork sections for these dampers are not being provided as mandated by the NFPA 80, rather inadequate small access doors are being installed in the ductwork system next to the fire and smoke damper. Small access doors don't provide the access needed to properly inspect and maintain the fire and smoke dampers. The inadequacies of these access doors is nothing new in the HVAC industry, in many cases when it becomes time for the periodic damper inspections the maintenance technician will ignore and pass over the small fire and smoke dampers knowing that it's virtually impossible to perform the inspection through the access doors. We are asking for your help in addressing this problem, these fire and smoke dampers are much to important to be ignored, they save lives and countless dollars in property damage, the solutions are known they are just not being implemented.

My recommendation would be to adopt the National Fire Protection Association (NFPA) standards as set forth in NFPA 80 - **19.2.3 Access.** Dampers equipped with fusible links, internal operators, or both shall be provided with an access door that is not less than 12 in. (305mm) square or provided with a removable duct section.

Cost Impact

The code change proposal will not increase or decrease the cost of construction .

The proposed change will reduce the time for inspecting and servicing fire dampers by 50%.

Internal ID: 141

M73-18

IMC: 602.2.1.7

Proponent: Marcelo Hirschler, GBH International, representing GBH International (gbhint@aol.com)

2018 International Mechanical Code

Revise as follows:

602.2.1.7 Plastic plumbing piping and tubing. Plastic piping and tubing used in plumbing systems shall be listed and labeled as having a flame spread index not greater than 25 and a smoke-developed index not greater than 50 when tested in accordance with ASTM E84 or UL 723. The testing shall be conducted without water within the pipe.

Exception: Plastic water distribution piping and tubing listed and labeled in accordance with UL 2846 as having a peak optical density not greater than 0.50, an average optical density not greater than 0.15, and a flame spread distance not greater than 5 feet (1524 mm), and installed in accordance with its listing.

Reason:

This proposal should be simple clarification but it highlights the fact that many approvals (even at ICC ES) are based on testing in accordance with a "modified" version of ASTM E84. One of the key modifications is the use of water within the pipes during testing. ASTM E84 does not authorize the use of water during testing of pipes (or of any other product). The reports indicate that a "modified" version of ASTM E84 has been used for the testing but that does not follow the intent (or the letter) of either ASTM E84 or the IMC. The intent of the use of products in plenums is for comparative testing of the products as received for inclusion in the plenum, and that does not include water.

This proposal has language very similar to that in M77 from the last cycle, and has the same effect. M77 was approved as submitted at the Public Comment hearing but failed in the Online Governmental Consensus Voting Process. I attach the full proposal and comment section for M77, with its associated information.

The language in M77 at the last cycle discussed the inclusion of "any liquid" within the pipe. The present proposal is more specific in that it states that it is not allowed to include water because that is the liquid that is being used. Note that fires in plenums typically occur during construction or renovation, when pipes are not full of water (or any other liquid). Note also that this section is generic for any plastic pipe in plenums and not exclusive to those carrying water.

The proposal was disapproved by the mechanical code committee because they felt it was not necessary for the code to clarify what is in the test standards. A variety of ICC ES approvals show that, in fact, products are being approved when tested with water, meaning that the clarification is important to ensure that there is an understanding that such "modifications" are not acceptable.

Cost Impact

The code change proposal will increase the cost of construction .

The effect of this change is that some pipe materials that are in use today with incorrect fire testing and/or incorrect listings will have to be replaced in new construction by safer materials tested in proper accordance with ASTM E84.

Internal ID: 172

M74-18

IMC: 604.3

Proponent: Mike Fischer, Kellen Company, representing The Center for the Polyurethanes Industry of the American Chemistry Council (mfischer@kellencompany.com)

2018 International Mechanical Code

Revise as follows:

604.3 Coverings and linings. ~~Coverings~~ Duct coverings and linings, including adhesives where used, shall have a flame spread index not more than 25 and a smoke-developed index not more than 50, when tested in accordance with ASTM E84 or UL 723, using the specimen preparation and mounting procedures of ASTM E2231. Duct coverings and linings shall not flame, glow, smolder or smoke when tested in accordance with ASTM C411 at the temperature to which they are exposed in service. The test temperature shall not fall below 250°F (121°C). Coverings and linings shall be listed and labeled.

Exception: Polyurethane foam insulation that is spray applied to the exterior of ducts in attics and crawlspaces shall be subject to all of the following requirements:

1. The foam plastic insulation shall have a flame spread index not greater than 25 and a smoke developed index not greater than 450, when tested in accordance with ASTM E84 or UL 723, using the specimen preparation and mounting procedures of ASTM E2231.
2. The foam plastic insulation shall not flame, glow, smolder or smoke when tested in accordance with ASTM C411 at the temperature to which they are exposed in service. The test temperature shall not fall below 250°F (121°C).
3. The foam plastic insulation complies with the requirements of Section 2603 of the International Building Code.
4. The foam plastic insulation is protected against ignition in accordance with the requirements of Section 2603.4.1.6 of the International Building Code.

Reason:

The proposal is the same as M98-15 PC1. M98 was approved as modified by the committee. PC1 was approved during the Public Comment hearing but failed to get the necessary majority in the online vote.

The proposal adds an exception allowing a greater smoke-developed index for some applications of foam plastic insulation on the exterior surfaces of ducts in attics or crawlspaces under certain specified conditions. The exception applies only to foam insulation meeting the requirements of IBC Section 2603 and the ignition barrier requirements in IBC Section 2603.4.1.6. This additional option is consistent with the options in Section M1601.3 of the IRC.

Cost Impact

The code change proposal will decrease the cost of construction .

The proposal will permit greater flexibility in material selection.

Internal ID: 1898

M75-18

IMC: 602.2.1.7

Proponent: Mike Fischer, Kellen Company, representing Self (mfischer@kellencompany.com)

2018 International Mechanical Code

Revise as follows:

602.2.1.7 Plastic plumbing piping and tubing. Plastic piping and tubing used in plumbing systems shall be listed and labeled as having a flame spread index not greater than 25 and a smoke-developed index not greater than 50 when tested in accordance with ASTM E84 or UL 723. Plastic piping and tubing shall be tested without water or other fluids within the test specimens.

Exception: Plastic water distribution piping and tubing listed and labeled in accordance with UL 2846 as having a peak optical density not greater than 0.50, an average optical density not greater than 0.15, and a flame spread distance not greater than 5 feet (1524 mm), and installed in accordance with its listing.

Reason:

This proposal is a revisiting of the debate on M77-15, which was approved during the PCH but failed to gather the required 2/3 majority during the online vote.

It should seem obvious that testing plastic pipes in the ASTM E84 Steiner Tunnel Test Chamber by filling them with water during testing would artificially improve the product's test performance. Evaluation reports issued by certification entities including ICC-ES have included testing in precisely that manner. ASTM E 84 cannot possibly cover every possible condition. It is important that the code provide clear guidance on this matter to ensure that the intended level of fire safety is met.

It is my opinion that testing plastic pipes- especially for drainage or condensate lines that are normally empty- is not currently permitted by the code. While Section 602.2.1.7 does not currently address test specimen preparation, ASTM E84 does not permit testing in this manner. The only way that testing plastic piping for use in plenums outside of the code-prescribed ASTM E84 test could be qualified, then, would be under Section 105.2 Alternative materials, design and methods of construction and equipment.

There is a catch, however; Section 105.2 provides guidance to the code official on alternative means and methods:

"An alternative material, design or method of construction shall be approved where the code official finds that the proposed design is satisfactory and complies with the intent of the provisions of this code, and that the material, method or work offered is, for the purpose intended, not less than the equivalent of that prescribed in this code in quality, strength, effectiveness, fire resistance, durability and safety."

Approval of pipes for flame spread rating with water in the specimen under a mutated version of ASTM E84 is not consistent with Section 105.2.

I ask the Mechanical Committee to approve this proposal and remove any doubt about the application of ASTM E84 for plastic piping and tubing.

Cost Impact

The code change proposal will not increase or decrease the cost of construction .

It is my opinion that the code does not currently permit testing plastic piping and tubing with water in the test specimens. For that reason, this code change is editorial and will assist with enforcement of the current provisions, not change the provisions.

Internal ID: 2200

M76-18

IMC: 602.1, 602.2, 602.2.1, 602.3, 602.3.3, 602.3.4, 602.3.5, 602.2.1.4, 602.2.1.4.1, 602.2.1.4.2, 602.3.1 (New), 602.3.2 (New), 602.3.6, 602.3.7, 602.3.8, 602.3.9, 602.3.10 (New), [BS] 602.4

Proponent: Pennie Feehan, representing Plumbing, Mechanical, and Fuel Gas Code Action Committee (PMGCAC@iccsafe.org)

2018 International Mechanical Code

602.1 General. Supply, return, exhaust, relief and ventilation air plenums shall be limited to uninhabited crawl spaces, areas above a ceiling or below the floor, attic spaces, mechanical equipment rooms and the framing cavities addressed in Section 602.3. Plenums shall be limited to one fire area. Air systems shall be ducted from the boundary of the fire area served directly to the air-handling equipment. Fuel-fired appliances shall not be installed within a plenum.

Revise as follows:

602.2 Construction of plenums. *Plenum* enclosure construction materials that are exposed to the airflow shall comply with the requirements of Section 703.5 of the International Building Code or such materials shall have a flame spread index of not more than 25 and a smoke-developed index of not more than 50 when tested in accordance with ASTM E84 or UL 723.

The use of gypsum boards to form plenums shall be limited to systems where the air temperatures do not exceed 125°F (52°C) and the building and mechanical system design conditions are such that the gypsum board surface temperature will be maintained above the airstream dew-point temperature. Air plenums formed by gypsum boards shall not be incorporated in air-handling systems utilizing evaporative coolers.

~~602.3~~**602.2.1 Stud cavity and joist space plenums.** Stud wall cavities and the spaces between solid floor joists to be utilized as air plenums shall comply with the following conditions:

1. Such cavities or spaces shall not be utilized as a *plenum* for supply air.
2. Such cavities or spaces shall not be part of a required fire-resistance-rated assembly.
3. Stud wall cavities shall not convey air from more than one floor level.
4. Stud wall cavities and joist space plenums shall comply with the floor penetration protection requirements of the International Building Code.
5. Stud wall cavities and joist space plenums shall be isolated from adjacent concealed spaces by *approved* fireblocking as required in the International Building Code.
6. Stud wall cavities in the outside walls of building envelope assemblies shall not be utilized as air plenums.

~~602.2.1~~**602.3 Materials within plenums.** ~~Except as required by Sections 602.2.1.1 through 602.2.1.8, materials~~ Materials within plenums shall be noncombustible or shall be listed and labeled as having a flame spread index of not more than 25 and a smoke-developed index of not more than 50 when tested in accordance with ASTM E84 or UL 723 in compliance with the applicable requirements in Sections 602.3.1 through 602.3.10.

Exceptions:

- ~~1. Rigid and flexible ducts and connectors shall conform to Section 603.~~
- ~~2. Duct coverings, linings, tape and connectors shall conform to Sections 603 and 604.~~
- ~~3. This section shall not apply to materials exposed within plenums in one- and two-family dwellings.~~
- ~~4. This section shall not apply to smoke detectors.~~
- ~~5.2.~~ Combustible materials fully enclosed within one of the following:
 - ~~5.1.2.1.~~ Continuous noncombustible raceways or enclosures.
 - ~~5.2.2.2.~~ Approved gypsum board assemblies.
 - ~~5.3.2.3.~~ Materials listed and labeled for installation within a plenum and listed for the application.
- ~~6.3.~~ Materials ~~This section shall not apply to materials~~ in Group H, Division 5 fabrication areas and the

areas above and below the fabrication area that share a common air recirculation path with the fabrication area.

~~602.2.1.1~~**602.3.3 Wiring.** Combustible electrical wires and cables and optical fiber cables exposed within a plenum shall be listed and labeled as having a peak optical density not greater than 0.50, an average optical density not greater than 0.15, and a flame spread distance not greater than 5 feet (1524 mm) when tested in accordance with NFPA 262, or shall be installed in metal raceways or metal sheathed cable. Combustible optical fiber and communication raceways exposed within a plenum shall be listed and labeled as having a peak optical density not greater than 0.5, an average optical density not greater than 0.15, and a flame spread distance not greater than 5 feet (1524 mm) when tested in accordance with UL 2024. Only plenum-rated wires and cables shall be installed in plenum-rated raceways.

~~602.2.1.2~~**602.3.4 Fire sprinkler piping.** Plastic fire sprinkler piping exposed within a *plenum* shall be used only in wet pipe systems and shall be listed and labeled as having a peak optical density not greater than 0.50, an average optical density not greater than 0.15, and a flame spread distance not greater than 5 feet (1524 mm) when tested in accordance with UL 1887.

~~602.2.1.3~~**602.3.5 Pneumatic tubing.** Combustible pneumatic tubing exposed within a *plenum* shall be listed and labeled as having a peak optical density not greater than 0.50, an average optical density not greater than 0.15, and a flame spread distance not greater than 5 feet (1524 mm) when tested in accordance with UL 1820.

Delete without substitution:

~~602.2.1.4~~ **Electrical equipment in plenums.** ~~Electrical equipment exposed within a plenum shall comply with Sections 602.2.1.4.1 and 602.2.1.4.2.~~

~~602.2.1.4.1~~ **Equipment in metallic enclosures.** ~~Electrical equipment with metallic enclosures exposed within a plenum shall be permitted.~~

~~602.2.1.4.2~~ **Equipment in combustible enclosures.** ~~Electrical equipment with combustible enclosures exposed within a plenum shall be listed and labeled for such use in accordance with UL 2043.~~

Add new text as follows:

602.3.1 Ducts, connectors, duct coverings, linings, and tape. Rigid and flexible ducts and connectors shall conform to Section 603. Duct coverings, linings, tape and connectors shall conform to Sections 603 and 604.

602.3.2 Smoke detectors. Smoke detectors shall be listed and labeled, and shall be installed with the sampling tubes included in the listing in accordance with the manufacturer's installation instructions, the International Building Code, and the International Fire Code.

Revise as follows:

~~602.2.1.5~~**602.3.6 Discrete electrical, plumbing and mechanical products in plenums.** Where discrete electrical, plumbing and mechanical products and appurtenances are located in a plenum and have exposed combustible material, they shall be listed and labeled for such use in accordance with UL 2043.

~~602.2.1.6~~**602.3.7 Foam plastic in plenums as interior finish or interior trim.** Foam plastic in plenums used as interior wall or ceiling finish or interior trim shall exhibit a flame spread index of 25 or less and a smoke-developed index of 50 or less when tested in accordance with ASTM E84 or UL 723 at the maximum thickness and density intended for use, and shall be tested in accordance with NFPA 286 and meet the acceptance criteria of Section 803.1.2 of the International Building Code. As an alternative to testing to NFPA 286, the foam plastic shall be approved based on tests conducted in accordance with Section 2603.9 of the International Building Code.

Exceptions:

1. Foam plastic in plenums used as interior wall or ceiling finish or interior trim shall exhibit a flame spread index of 75 or less and a smoke developed index of 450 or less when tested in accordance with ASTM E84 or UL 723 at the maximum thickness and density intended for use, where it is separated from the airflow in the plenum by a thermal barrier complying with Section 2603.4 of the International Building Code.
2. Foam plastic in plenums used as interior wall or ceiling finish or interior trim, shall exhibit a flame

spread index of 75 or less and a smokedeveloped index of 450 or less when tested in accordance with ASTM E84 or UL 723 at the maximum thickness and density intended for use, where it is separated from the airflow in the plenum by corrosion-resistant steel having a base metal thickness of not less than 0.0160 inch (0.4 mm).

3. Foam plastic in plenums used as interior wall or ceiling finish or interior trim, shall exhibit a flame spread index of 75 or less and a smokedeveloped index of 450 or less when tested in accordance with ASTM E84 or UL 723 at the maximum thickness and density intended for use, where it is separated from the airflow in the plenum by not less than a 1-inch (25 mm) thickness of masonry or concrete.

~~602.2.1-7~~602.3.8 Plastic plumbing piping and tubing. Plastic piping and tubing used in plumbing systems shall be listed and labeled as having a flame spread index not greater than 25 and a smoke-developed index not greater than 50 when tested in accordance with ASTM E84 or UL 723.

Exception: Plastic water distribution piping and tubing listed and labeled in accordance with UL 2846 as having a peak optical density not greater than 0.50, an average optical density not greater than 0.15, and a flame spread distance not greater than 5 feet (1524 mm), and installed in accordance with its listing.

~~602.2.1-8~~602.3.9 Pipe and duct insulation within plenums. Pipe and duct insulation contained within plenums, including insulation adhesives, shall have a flame spread index of not more than 25 and a smoke developed index of not more than 50 when tested in accordance with ASTM E84 or UL 723, using the specimen preparation and mounting procedures of ASTM E2231. Pipe and duct insulation shall not flame, glow, smolder or smoke when tested in accordance with ASTM C411 at the temperature to which they are exposed in service. The test temperature shall not fall below 250°F(121°C). Pipe and duct insulation shall be listed and labeled.

Add new text as follows:

602.3.10 Other combustible materials. Other combustible materials not covered by Section 602.3 shall be listed and labeled as having a flame spread index of not more than 25 and a smoke-developed index of not more than 50 when tested in accordance with ASTM E84 or UL 723.

[BS] 602.4 Flood hazard. For structures located in flood hazard areas, plenum spaces shall be located above the elevation required by Section 1612 of the International Building Code for utilities and attendant equipment or shall be designed and constructed to prevent water from entering or accumulating within the plenum spaces during floods up to such elevation. If the plenum spaces are located below the elevation required by Section 1612 of the International Building Code for utilities and attendant equipment, they shall be capable of resisting hydrostatic and hydrodynamic loads and stresses, including the effects of buoyancy, during the occurrence of flooding up to such elevation.

Reason:

This proposal does not intend to make any technical changes to the existing requirements. The intent of this proposal is to provide clarity as to what various materials are permitted within a plenum under specific conditions. The current Sections 602.2 and 602.3 are requirements for the constructing the plenum, and thus the current Section 602.3 should be a subsection of Section 602.2. Section 602.2.1 and its subsections are not for the construction of the plenum, but what materials are permitted within the plenum, and thus should not be a subsection of Section 602.2.

This proposal is submitted by the ICC Plumbing/Mechanical/Gas Code Action Committee (PMG CAC). The PMG CAC was established by the ICC Board of Directors to pursue opportunities to improve and enhance the International Codes or portions thereof that were under the purview of the PMG CAC. In 2017 the PMG CAC held one face-to-face meeting and 11 conference call meetings. Numerous interested parties attended the committee meetings and offered their input.

Cost Impact

The code change proposal will not increase or decrease the cost of construction .

This proposal will not increase the cost of construction because no additional labor, materials, equipment, appliances or devices are mandated beyond what is currently required by the code.

Internal ID: 487

M77-18

IMC: 606.2

Proponent: Raymond Grill, representing Self (ray.grill@arup.com)

2018 International Mechanical Code

Revise as follows:

606.2 Where required. Smoke detectors shall be installed where indicated in Sections 606.2.1 through 606.2.3.

Exception: Smoke detectors shall not be required where air distribution systems are incapable of spreading smoke beyond the ~~enclosing walls, floors and ceilings of the room or space~~ floor or smoke compartment in which the smoke is generated.

Reason:

The current exception is too limiting. It has been interpreted to not be allowed when there are more than one room on a floor. While smoke spread can occur much easier through a door opening than through a duct. The system have smoke detector activated shut off to prevent smoke spreading to other floors, smoke compartments on a floor or areas of the building.

Cost Impact

The code change proposal will decrease the cost of construction .

The provision of smoke detectors for automatic shut in the case of having more than one "room" on a floor is excessively costly. Each additional duct detector can cost \$500 and up depending on the location and installation constraints. The devices also require regular testing which increases operating costs.

Internal ID: 2316

M78-18 Part I

IMC: 602.1,

Proponent: Robert Schwarz, representing EnergyLogic, Inc. (robby@nrglogic.com)

THIS IS A 2 PART CODE CHANGE PROPOSAL. PART I WILL BE HEARD BY THE IMC COMMITTEE AND PART II WILL BE HEARD BY THE IRC M/P COMMITTEE. PLEASE SEE THE HEARING ORDERS FOR THESE COMMITTEES.

2018 International Mechanical Code

Revise as follows:

602.1 General. Supply, return, exhaust, relief and ventilation air plenums shall be limited to uninhabited crawl spaces, areas above a ceiling or below the floor, attic spaces, and mechanical equipment rooms, ~~and the framing cavities addressed in Section 602.3~~ Plenums shall be limited to one fire area. Air systems shall be ducted from the boundary of the fire area served directly to the air-handling equipment. Fuel-fired appliances shall not be installed within a

Delete without substitution:

~~**602.3 Stud cavity and joist space plenums.** Stud wall cavities and the spaces between solid floor joists to be utilized as air plenums shall comply with the following conditions:~~

- ~~1. Such cavities or spaces shall not be utilized as a *plenum* for supply air.~~
- ~~2. Such cavities or spaces shall not be part of a required fire resistance rated assembly.~~
- ~~3. Stud wall cavities shall not convey air from more than one floor level.~~
- ~~4. Stud wall cavities and joist space plenums shall comply with the floor penetration protection requirements of the International Building Code.~~
- ~~5. Stud wall cavities and joist space plenums shall be isolated from adjacent concealed spaces by *approved* fireblocking as required in the International Building Code.~~
- ~~6. Stud wall cavities in the outside walls of building envelope assemblies shall not be utilized as air plenums.~~

Internal ID: 3474

M78-18 Part II

IRC: M1601.1.1

Proponent: Robert Schwarz, representing EnergyLogic, Inc. (robby@nrglogic.com)

2018 International Residential Code

Revise as follows:

M1601.1.1 Above-ground duct systems. Above-ground *duct systems* shall conform to the following:

1. *Equipment* connected to *duct systems* shall be designed to limit discharge air temperature to not greater than 250°F (121°C).
2. Factory-made ducts shall be listed and labeled in accordance with UL 181 and installed in accordance with the manufacturer's instructions.
3. Fibrous glass duct construction shall conform to the SMACNA *Fibrous Glass Duct Construction Standards* or NAIMA *Fibrous Glass Duct Construction Standards*.
4. Field-fabricated and shop-fabricated metal and flexible duct constructions shall conform to the SMACNA *HVAC Duct Construction Standards—Metal and Flexible* except as allowed by Table M1601.1.1. Galvanized steel shall conform to ASTM A653.
5. The use of gypsum products to construct return air ducts or plenums is permitted, provided that the air temperature does not exceed 125°F (52°C) and exposed surfaces are not subject to condensation.
6. *Duct systems* shall be constructed of materials having a flame spread index of not greater than 200.
7. ~~Stud wall cavities and the spaces between solid floor joists to be used as air plenums shall comply with the following conditions:~~
 - ~~7.1.7. These cavities or spaces shall~~ Building framing cavities shall not be used as a plenum for supply air.
 - ~~7.2. These cavities or spaces shall not be part of a required fire-resistance-rated assembly.~~
 - ~~7.3. Stud wall cavities shall not convey air from more than one floor level.~~
 - ~~7.4. Stud wall cavities and joist space plenums shall be isolated from adjacent concealed spaces by tight fitting fireblocking in accordance with Section R602.8.~~
 - ~~7.5. Stud wall cavities in the outside walls of building envelope assemblies shall not be utilized as air ducts or plenums.~~
8. Volume dampers, equipment and other means of supply, return and exhaust air adjustment used in system balancing shall be provided with access.

Reason:

This code change proposal will create alignment between the IECC and the IMC as the IECC does not allow building cavities to be used as duct work that is seeing pressure from the air handling unit. It is impossible to control the air that is being pushed and pulled through building cavities that are used as ducts. When you pan a floor system for example, the air that is returning to the furnace comes from many more places than the room the intended. Air, having a tremendous ability to transport moisture, energy, and pollutants needs to be better controlled than is possible by using building cavities as duct work and therefore HVAC systems need to be fully ducted. The Energy Code recognizes the Building durability, efficiency, and safety concerns with gaining better control of air flow that is being pushed and pulled by the hair handling. Moisture control, energy control, pollutant control, house and room pressure control are all gained by fully ducting HVAC systems and not allowing building cavities to be used as duct work.

Cost Impact

The code change proposal will increase the cost of construction .

This Code proposal will increase the code of construction because it will require fully ducted HVAC systems which improving durability, safety, and effincy of the building we build

Internal ID: 1604

M79-18

IMC: 703 (New)

Proponent: Ted Williams, American Gas Association, representing American Gas Association (twilliams@aga.org)

2018 International Mechanical Code

Add new text as follows:

701.3 Outdoor Combustion Air. In Climate Zones 3 through 8, where outdoor combustion air is provided to a room containing a space-heating fuel burning appliance, and such room is within the thermal envelope of the building, the outdoor combustion air shall be tempered.

Exceptions:

1. The room is sealed and insulated in accordance with the requirements of Section R402.4.4 or C402.5.3 of the International Energy Conservation Code.
2. The appliance is a direct-vent appliance.
3. An automatic means to stop the flow of outdoor air during the off cycle of the appliance shall be provided in combustion air openings or in combustion air ducts.

Reason:

Limitation of inflow of cold unconditioned combustion air to appliance rooms is needed to address unsafe behaviors such as blocking outdoor combustion air inlets in winter to maintain appliance room temperatures that are consistent with the rest of the conditioned space. The proposal limits inflow of cold unconditioned air to the conditioned space during off-cycles of the appliance by requiring combustion air tempering or other means. Other means, allowed by exception, include applying the sealing and insulating requirements of the International Energy Conservation Code, restricting appliance types to those that would not pull cold unconditioned air into the appliance room itself, or installation of “J traps” or other combustion air ducting designs that have been shown to limit inflow of unconditioned air during appliance off cycles. On-cycle room temperatures would continue to be augmented by appliance jacket losses and venting system heat losses to the room during appliance operation.

Cost Impact

The code change proposal will not increase or decrease the cost of construction .

Outdoor combustion air tempering can be addressed by installing tempering intake fan systems to existing combustion air ductwork at a small incremental cost. Alternatively and through one of the proposed exceptions, “J trap” combustion air duct work can be installed at minimal incremental cost. Either of these approaches represent insignificant costs relative to thermally isolating the room containing the combustion appliances (also to be permitted as an exception in the proposal as an option that would be consistent with the International Energy Conservation Code).

Internal ID: 2007

M80-18

IMC: 801.21 (New)

Proponent: Pennie Feehan, representing Plumbing, Mechanical, and Fuel Gas Code Action Committee (PMGCAC@iccsafe.org)

2018 International Mechanical Code

Add new text as follows:

801.21 Blocked vent switch. The venting system for oil-fired appliances shall be equipped with a device that will stop burner operation in the event that the venting system is obstructed. Such device shall have a manual reset, and shall be installed in accordance with the manufacturer's instructions.

Reason:

Such devices can save lives in the event that a chimney or Type L vent is blocked by debris, decaying masonry or dead animals. Gas furnaces are equipped with thermal and/or pressure devices that will sense failure of the venting system, but such is not known to be required for oil-fired appliances. Such devices have been installed for many decades, but not necessarily required. These devices are typically provided for or are an option for draft regulators that are commonly installed in the vent of oil-fired appliances.

This proposal is submitted by the ICC Plumbing/Mechanical/Gas Code Action Committee (PMG CAC). The PMG CAC was established by the ICC Board of Directors to pursue opportunities to improve and enhance the International Codes or portions thereof that were under the purview of the PMG CAC. In 2017 the PMG CAC held one face-to-face meeting and 11 conference call meetings. Numerous interested parties attended the committee meetings and offered their input.

Cost Impact

The code change proposal will increase the cost of construction .

This proposal will increase the cost of construction because an additional device is mandated beyond what is currently required by the code.

Internal ID: 383

M81-18

IMC: SECTION 920.4 (New)

Proponent: John Williams, Chair, representing Healthcare Committee (AHC@iccsafe.org)

2018 International Mechanical Code

SECTION 920 UNIT HEATERS

920.1 General. Unit heaters shall be installed in accordance with the listing and the manufacturer's instructions. Oil-fired unit heaters shall be tested in accordance with UL 731.

920.2 Support. Suspended-type unit heaters shall be supported by elements that are designed and constructed to accommodate the weight and dynamic loads. Hangers and brackets shall be of noncombustible material. Suspended-type oil-fired unit heaters shall be installed in accordance with NFPA 31.

920.3 Ductwork. A unit heater shall not be attached to a warm-air duct system unless *listed* for such installation.

Add new text as follows:

920.4 Prohibited Uses. In Group I-2 and ambulatory care facilities, suspended-type unit heaters are prohibited in corridors, exit access stairways and ramps, exit stairways and ramps and patient sleeping areas.

Reason:

Suspended type heaters should not be in the means of egress because of the element of risk for these types of heaters, such as open flame, carbon monoxide and other products of combustion. Fuel being piped to these heaters could be an additional risk. The defend in place concept relies on the means of egress to temporarily house residents and patients (K523).

This proposal is submitted by the ICC Committee on Healthcare (CHC). The CHC was established by the ICC Board to evaluate and assess contemporary code issues relating to healthcare facilities. This is a joint effort between ICC and the American Society for Healthcare Engineering (ASHE), a subsidiary of the American Hospital Association, to eliminate duplication and conflicts in healthcare regulation. In 2017 the CHC held 2 open meetings and numerous conference calls, which included members of the committees as well as any interested parties, to discuss and debate the proposed changes. Information on the CHC, including: meeting agendas; minutes; reports; resource documents; presentations; and all other materials developed in conjunction with the CHC effort can be downloaded from the CHC website at: <https://www.iccsafe.org/codes-tech-support/cs/icc-committee-on-healthcare/>.

Cost Impact

The code change proposal will not increase or decrease the cost of construction .

The elimination of this type of heater unit will not add cost to these types of facilities

Internal ID: 634

M82-18

IMC: 929, 929.1, 202

Proponent: Tessa Quinones, The Hickman Group, representing MacroAir Technologies, Inc.
(admin@thehickmangroup.com)

2018 International Mechanical Code

Revise as follows:

SECTION 929 ~~HIGH-VOLUME-LARGE-DIAMETER~~ CEILING FANS

929.1 General. Where provided, ~~high-volume-large-diameter~~ ceiling fans shall be tested and labeled in accordance with AMCA 230, listed and labeled in accordance with UL 507, and installed in accordance with the manufacturer's instructions.

~~HIGH-VOLUME, LARGE-DIAMETER~~ CEILING FAN. A ~~low-speed~~ low-speed ceiling fan that circulates large volumes of air and that is greater than 7 feet (2134 mm) in diameter. These fans are sometimes referred to as High-Volume, Low-Speed (HVLS) fans.

Reason:

This proposal aligns the IMC large diameter ceiling fan terminology with the DOE definitions per test standard 10-CFR-Part 430-Appendix U, Section 1.14, as published in 2016.

Cost Impact

The code change proposal will not increase or decrease the cost of construction .

This is only an editorial revision; changing terminology.

Internal ID: 1146

M83-18

IMC: 905.1

Proponent: Tom Stroud, representing Hearth, Patio, and Barbecue Association (stroud@hpba.org)

2018 International Mechanical Code

Revise as follows:

905.1 General. Fireplace stoves and solid-fuel-type room heaters shall be *listed* and *labeled* and shall be installed in accordance with the conditions of the listing. Fireplace stoves shall be tested in accordance with UL 737. Solid-fuel-type room heaters shall be tested in accordance with UL 1482. Fireplace inserts intended for installation in fireplaces shall be *listed* and *labeled* in accordance with the requirements of UL 1482 and shall be installed in accordance with the manufacturer's instructions. New Wood Burning Residential Hydronic Heaters shall be EPA certified

Reason:

Over the last few years there have been numerous states that have been banning outdoor hydronic heaters, the reason being that they were very dirty. In work with ASTM and EPA, the units that are now being certified are a completely different product and should be considered as such and allowed by code. If the product is going to be installed, they need to be EPA certification standards.

Cost Impact

The code change proposal will not increase or decrease the cost of construction .

Currently the only Outdoor Hydronic Heaters being sold in the US are required to meet EPA Certification, so there is not a cost impact related to the installation. This code addition would allow the money spent for the unit could meet the approval by the AHJ.

Internal ID: 1796

M84-18

IMC: 929, 929.1, 202

Proponent: Amanda Hickman, The Hickman Group, representing AMCA International (amanda@thehickmangroup.com)

2018 International Mechanical Code

Revise as follows:

SECTION 929 ~~HIGH-VOLUME-LARGE-DIAMETER~~ CEILING FANS

929.1 General. Where provided, ~~high-volume-large-diameter~~ ceiling fans shall be tested and labeled in accordance with AMCA 230, listed and labeled in accordance with UL 507, and installed in accordance with the manufacturer's instructions.

~~HIGH-VOLUME, LARGE-DIAMETER~~ CEILING FAN. A ~~low-speed~~ ceiling fan that ~~circulates large volumes of air and that is~~ greater than 7 feet (2134 mm) in diameter. These fans are sometimes referred to as High-Volume, Low-Speed (HVLS) fans.

Reason:

This proposal intends to align IMC terminology for large diameter ceiling fans to be consistent with that of the terminology in the DOE definitions per test standard 10-CFR-Part 430-Appendix U, Section 1.14, as published in 2016. https://www.law.cornell.edu/cfr/text/10/appendix-U_to_subpart_B_of_part_430

Cost Impact

The code change proposal will not increase or decrease the cost of construction .

This is a title change only, removing "High-Volume" from the title does not impact cost

Internal ID: 1117

M85-18

IMC: 202, 202 (New), SECTION 929 (New), 929.1 (New), Chapter 15, 15

Proponent: Bo Manalo, EcoSmart Inc., representing EcoSmart Inc. (bo@ecosmartfire.com)

2018 International Mechanical Code

Add new definition as follows:

SECTION 202 GENERAL DEFINITIONS

UNVENTED ALCOHOL FUEL BURNING DECORATIVE APPLIANCE. A stationary, self-contained appliance intended to be directly or indirectly secured to a wall or floor and not intended for duct connection. Such appliance burns alcohol and is made in a manufacturing facility for subsequent delivery to the installation site.

Add new text as follows:

SECTION 929 UNVENTED ALCOHOL FUEL BURNING DECORATIVE APPLIANCES

929.1 GENERAL. Unvented alcohol fuel-burning decorative appliances shall be listed and labeled in accordance with UL1370 and shall be installed in accordance with the conditions of the listing, manufacturer's installation instructions, and Chapter 3.

Add new standard(s) follows:

CHAPTER 15 REFERENCED STANDARDS

UL

UL LLC
333 Pfingsten Road
Northbrook IL 60062-2096

UL1370-11:

Unvented Alcohol Fuel Burning Decorative Appliances, with revisions through March 25, 2016

Reason:

This proposal adds a provision for a newer type of decorative appliance. It provides clear and specific requirements for the installation of unvented, self-contained alcohol fuel burning appliances. The requisite ANSI consensus UL Standard 1370 includes performance-based criteria that provide a consistent application of requirements and best practices to ensure safe installation and operation. The Standard includes combustion testing for carbon dioxide and carbon monoxide emission limits, oxygen depletion, materials and construction requirements. The Standard also tests for user abuse testing, stability, temperature, and wind tests.

These appliances are intended for decorative purposes and not intended to be utilized as a primary heat source. Denatured alcohol is formulated for the application and limited to a maximum input rate of 0.25 gallons of fuel per hour (0.95 liters per hour). They are not provided with means for duct connection nor is there electric/mechanical assist of heated air movement, such as a fan-blower assembly. The appliances are labeled with minimum room volume requirements for installation.

The proposal improves the Code by providing installers and building officials with a clear path on specifications that pertain to these products. Installation is intended to be in accordance with local codes, the manufacturer's installation instructions and markings on the appliance.

Cost Impact

The code change proposal will increase the cost of construction .

This may reduce the cost of construction by simplifying the design/review process.

Analysis: A review of the standard proposed for inclusion in the code, with regard to the ICC criteria for referenced standards (Section 3.6 of CP#28) will be posted on the ICC website on or before April 2, 2018.

Internal ID: 1616

M86-18 Part I

IMC: 908.1, 916.1, 918.1, 918.2, 1101.2, 15

Proponent: Jonathan Roberts, UL LLC, representing UL LLC (jonathan.roberts@ul.com)

THIS IS A 2 PART CODE CHANGE PROPOSAL. PART I WILL BE HEARD BY THE IMC COMMITTEE AND PART II WILL BE HEARD BY THE IRC M/P COMMITTEE. PLEASE SEE THE HEARING ORDERS FOR THESE COMMITTEES.

2018 International Mechanical Code

Revise as follows:

908.1 General. A cooling tower used in conjunction with an air-conditioning *appliance* shall be installed in accordance with the manufacturer's instructions. Factory-built cooling towers shall be listed in accordance with UL 1995, or UL/CSA 60335-2-40.

916.1 General. Pool and spa heaters shall be installed in accordance with the manufacturer's instructions. Oil-fired pool and spa heaters shall be tested in accordance with UL 1261. Pool and spa heat pump water heaters shall comply with UL 1995, or UL/CSA 60335-2-40, or CSA C22.2 No. 236.

Exception:

Portable residential spas and portable residential exercise spas shall comply with UL 1563 or CSA C22.2 No. 218.1.

918.1 Forced-air furnaces. Oil-fired furnaces shall be tested in accordance with UL 727. Electric furnaces shall be tested in accordance with UL 1995, or UL/CSA 60335-2-40. Solid fuel furnaces shall be tested in accordance with UL 391. Forced-air furnaces shall be installed in accordance with the listings and the manufacturer's instructions.

918.2 Heat pumps. Electric heat pumps shall be tested in accordance with UL 1995, or UL/CSA 60335-2-40.

1101.2 Factory-built equipment and appliances. *Listed* and *labeled* self-contained, factory-built *equipment* and appliances shall be tested in accordance with UL 207, UL 412, UL 471 ~~or 1995, UL1995, UL/CSA 60335-2-40, or UL 60335-2-89.~~ Such *equipment* and appliances are deemed to meet the design, manufacture and factory test requirements of this code if installed in accordance with their listing and the manufacturer's instructions.

Add new standard(s) follows:

UL

UL LLC
333 Pfingsten Road
Northbrook IL 60062-2096

UL/CSA 60335-2-40 -17:

Household and Similar Electrical Appliances - Safety - Part 2-40: Particular Requirements for Electrical Heat Pumps, Air-Conditioners and Dehumidifiers.

UL 60335-2-89-17:

Household and Similar Electrical Appliances - Safety - Part 2-89: Particular Requirements for Commercial Refrigerating Appliances with an Incorporated or Remote Refrigerant Unit or Compressor

Analysis: A review of the standard proposed for inclusion in the code, with regard to the ICC criteria for referenced standards (Section 3.6 of CP#28) will be posted on the ICC website on or before April 2, 2018.

Internal ID: 424

M86-18 Part II

IRC: M1402.1, M2006.1, 44

Proponent: Jonathan Roberts, UL LLC, representing UL LLC (jonathan.roberts@ul.com)

2018 International Residential Code

Revise as follows:

M1402.1 General. Oil-fired central furnaces shall conform to ANSI/UL 727. Electric furnaces shall conform to UL 1995 or UL/CSA 60335-2-40.

M2006.1 General. Pool and spa heaters shall be installed in accordance with the manufacturer's installation instructions. Oil-fired pool heaters shall comply with UL 726. Electric pool and spa heaters shall comply with UL 1261. Pool and spa heat pump water heaters shall comply with UL 1995, UL/CSA 60335-2-40 or CSA C22.2 No. 236.

Exception: Portable residential spas and portable residential exercise spas shall comply with UL 1563 or CSA C22.2 No. 218.1.

Update standard(s) as follows:

UL

UL LLC
333 Pfingsten Road
Northbrook IL 60062

UL/CSA ~~ANCE 60335-2-40—201240—2017~~:

Standard for Household and Similar Electrical Appliances, Part 2: Particular Requirements for ~~Motor-compressors~~ Electrical Heat Pumps, Air-Conditioners and Dehumidifiers

Reason:

The UL Standard for Safety for Heating and Cooling Equipment, UL 1995 will be phased out by the year 2020, and will be replaced by UL 60335-2-40, the Standard for Safety for Household and Similar Electrical Appliances, Part 2-40: Particular Requirements for Electrical Heat Pumps, Air-Conditioners and Dehumidifiers. UL 60335-2-40 is harmonized with requirements in Canada and Europe. These requirements include provisions for the most current technology and use of flammable refrigerants, and is currently being used to list new products. UL 412 and UL 471 will be phased out by the year 2020 and will be replaced by UL 60335-2-89.

Cost Impact

The code change proposal will not increase or decrease the cost of construction .

It is not anticipated that the change in the product standards will increase the cost of construction.

Internal ID: 3440

M87-18

IMC: 1004.1

Proponent: Donald Jones, Representing myself only - not my employer, representing Self (donald_m_jones@att.net)

2018 International Mechanical Code

Revise as follows:

1004.1 Standards. Boilers shall be designed, constructed and certified in accordance with the ASME Boiler and Pressure Vessel Code, Section I or IV. Controls and safety devices for boilers with fuel input ratings of less than 12,500,000 Btu/hr (3,662,500 W) ~~or less~~ shall meet the requirements of ASME CSD-1. Controls and safety devices for boilers with inputs greater than or equal to 12,500,000 Btu/hr (3,662,500 W) shall meet the requirements of NFPA 85. Packaged oil-fired boilers shall be listed and labeled in accordance with UL 726. Packaged electric boilers shall be listed and labeled in accordance with UL 834. Solid-fuel-fired boilers shall be listed and labeled in accordance with UL 2523.

Reason:

The IMC jurisdictional references to ASME CSD-1 and NFPA 85 are incorrect -- slightly. Per the IMC, boilers rated 12,500,000 Btu/h are within the jurisdiction of CSD-1; this is **not** correct. The IMC needs to be modified to reflect the proper application of referenced codes. NFPA 85 has jurisdiction of boilers **12,500,000 Btu/h and greater**; CSD-1 includes **boilers less than 12.5 million Btu/h**.

Bibliography:

NFPA 85 Chapter 1 Administration 1.1 Scope

Chapter 1 Administration

1.1* Scope. This code applies to the following:

- (1) Single burner boilers, multiple burner boilers, stokers, and atmospheric fluidized bed boilers with a fuel input rating of 3.7 MWt (12.5 million Btu/hr) or greater

Description of CSD-1 from ASME website:

The rules of this Standard cover requirements for the assembly, installation, maintenance, and operation of controls and safety devices on automatically operated boilers directly fired with gas, oil, gas-oil, or electricity, having fuel input ratings under 12,500,000 Btu/hr.

[https://www.asme.org/products/codes-standards/csd1-2015-controls-safety-devices-automaticall-\(1\)](https://www.asme.org/products/codes-standards/csd1-2015-controls-safety-devices-automaticall-(1))

Cost Impact

The code change proposal will not increase or decrease the cost of construction .

Boiler installations are already required to adhere to the referenced codes (according to the revised IMC text), so this "code change" has no effect on construction costs.

Internal ID: 1474

M88-18

IMC: Chapter 2, SECTION 202, 202, 202 (New), 202, Chapter 11, SECTION 1101, 1101.2, SECTION 1103, 1103.1, TABLE 1103.1, SECTION 1104, 1104.3, 1104.3.1, 1104.3.1.1 (New), 1104.3.1.1.1 (New), 1104.3.1.1.2 (New), 1104.3.1.1.3 (New), 1104.3.1.1.4 (New)

Proponent: Connor Barbaree, ASHRAE, representing ASHRAE (cbarbaree@ashrae.org)

2018 International Mechanical Code

CHAPTER 2 DEFINITIONS

SECTION 202 GENERAL DEFINITIONS

Revise as follows:

FLAMMABILITY CLASSIFICATION (REFRIGERANT). ~~Refrigerants shall be assigned to one of the three classes 1, 2 or 3 in accordance with ASHRAE 34. For Classes 2 and 3, the heat of combustion shall be calculated assuming that combustion products are in the gas phase and in their most stable state. The alphabetical/numerical designation used to identify the flammability of refrigerants.~~

Class 1. ~~Refrigerants that do not show flame propagation when tested in air at 14.7 psia (101 kPa) and 140°F (60°C). Indicates a refrigerant with no flame propagation.~~

Class 2L. Indicates a refrigerant with lower flammability and lower burning velocity.

Class 2. ~~Refrigerants having a lower flammability limit (LFL) of more than 0.00625 pound per cubic foot (0.10 kg/m³) at 140°F (60°C) and 14.7 psia (101 kPa) and a heat of combustion of less than 8169 Btu/lb (19 000 kJ/kg). Indicates a refrigerant with lower flammability.~~

Class 3. ~~Refrigerants that are highly flammable, having a LFL of less than or equal to 0.00625 pound per cubic foot (0.10 kg/m³) at 140°F (60°C) and 14.7 psia (101 kPa) or a heat of combustion greater than or equal to 8169 Btu/lb (19 000 kJ/kg). Indicates a refrigerant with higher flammability.~~

Add new definition as follows:

REFRIGERANT CONCENTRATION LIMIT (REFRIGERANT) (RCL) The refrigerant concentration limit, in air, intended to reduce the risks of acute toxicity, asphyxiation, and flammability hazards in normally occupied, enclosed spaces.

Revise as follows:

REFRIGERANT SAFETY CLASSIFICATIONS GROUP CLASSIFICATION. ~~Groupings that indicate the toxicity and flammability classes in accordance with Section 1103.1. The classification group is made up of a letter (A or B) that indicates the toxicity class, followed by a number (1, 2 or 3) that indicates the flammability class. Refrigerant blends are similarly classified, based on the compositions at their worst cases of fractionation, as separately determined for toxicity and flammability. In some cases, the worst case of fractionation is the original formulation. The alphabetical/numerical designation that indicates both toxicity and flammability classifications of refrigerants.~~

Toxicity. See "Toxicity classification (Refrigerant)."

Flammability. See "Flammability classification (Refrigerant)."

TOXICITY CLASSIFICATION CLASSIFICATION (REFRIGERANT). ~~Refrigerants shall be classified for toxicity in one of two classes in accordance with ASHRAE 34:~~An alphabetical designation used to identify the toxicity of refrigerants. Class A indicates a refrigerant with lower toxicity. Class B indicates a refrigerant with higher toxicity.

CHAPTER 11 REFRIGERATION

SECTION 1101 GENERAL

1101.2 Factory-built equipment and appliances. *Listed and labeled* self-contained, factory-built *equipment* and appliances shall be tested in accordance with UL 207, 412, 471 ~~or 1995-, 484, 541, 1995, 60335-2-24, 60335-2-40 or 60335-2-89.~~ Such *equipment* and appliances are deemed to meet the design, manufacture and factory test requirements of this code if installed in accordance with their listing and the manufacturer's instructions.

SECTION 1103 REFRIGERATION SYSTEM CLASSIFICATION

1103.1 Refrigerant classification. Refrigerants shall be classified in accordance with ASHRAE 34 as listed in Table 1103.1. Each refrigerant shall be assigned to one of the following refrigerant safety group classifications: A1, A2L, A2, A3, B1, B2L, B2, or B3. For refrigerants that do not have values in Table 1103.1, the safety group, RCL value, and OEL value shall be determined in accordance with ASHRAE 34 and approved.

TABLE 1103.1

REFRIGERANT CLASSIFICATION, AMOUNT AND OEL

CHEMICAL REFRIGERANT	FORMULA	CHEMICAL NAME OF BLEND	REFRIGERANT SAFETY GROUP CLASSIFICATION	AMOUNT OF REFRIGERANT PER OCCUPIED SPACE				[F] DEGREES OF HAZARD ^a
				RCL			OEL ^c	
				lb per 1000 ft ³ Pounds per 1,000 cubic feet	ppm	g/m ³	ppm	
R-11 ^d	CCl ₃ F	trichlorofluoromethane	A1	0.39	1,100	6.2	1,000	2-0-0 ^b
R-12 ^d	CCl ₂ F ₂	dichlorodifluoromethane	A1	5.6	18,000	90	1,000	2-0-0 ^b
R-13 ^d	CClF ₃	chlorotrifluoromethane	A1	—	—	—	1,000	2-0-0 ^b
R-13B1 ^d	CBrF ₃	bromotrifluoromethane	A1	—	—	—	1,000	2-0-0 ^b
R-14	CF ₄	tetrafluoromethane (carbon tetrafluoride)	A1	25	110,000	400	1,000	2-0-0 ^b
R-22	CHClF ₂	chlorodifluoromethane	A1	13	59,000	210	1,000	2-0-0 ^b
R-23	CHF ₃	trifluoromethane (fluoroform)	A1	7.3	41,000	120	1,000	2-0-0 ^b
R-30	CH ₂ Cl ₂	dichloromethane (methylene chloride)	B1	—	—	—	—	—
R-32	CH ₂ F ₂	difluoromethane (methylene fluoride)	A2L, A2 ^f	4.8	36,000	77	1,000	1-4-0
R-40	CH ₃ Cl	chloromethane (methyl chloride)	B2	—	—	—	—	—
R-50	CH ₄	methane	A3	—	—	—	1,000	—
R-113 ^d	CCl ₂ CClF ₂	1,1,2-trichloro-1,1,2-trifluoroethane	A1	1.2	2,600	20	1,000	2-0-0 ^b
R-114 ^d	CClF ₂ CClF ₂	1,2-dichloro-1,1,2,2-tetrafluoroethane	A1	8.7	20,000	140	1,000	2-0-0 ^b
R-115	CClF ₂ CF ₃	chloropentafluoroethane	A1	47	120,000	760	1,000	—
R-116	CF ₃ CF ₃	hexafluoroethane	A1	34	97,000	550	1,000	1-0-0
R-123	CHCl ₂ CF ₃	2,2-dichloro-1,1,1-trifluoroethane	B1	3.5	9,100	57	50	2-0-0 ^b
R-124	CHClFCF ₃	2-chloro-1,1,1,2-tetrafluoroethane	A1	3.5	10,000	56	1,000	2-0-0 ^b
R-125	CHF ₂ CF ₃	pentafluoroethane	A1	23	75,000	370	1,000	2-0-0 ^b
R-134a	CH ₂ FCF ₃	1,1,1,2-tetrafluoroethane	A1	13	50,000	210	1,000	2-0-0 ^b
R-141b	CH ₃ CCl ₂ F	1,1-dichloro-1-fluoroethane	—	0.78	2,600	12	500	2-1-0
R-142b	CH ₃ CClF ₂	1-chloro-1,1-difluoroethane	A2	5.1	20,000	83	1,000	2-4-0
R-143a	CH ₃ CF ₃	1,1,1-trifluoroethane	A2L, A2 ^f	4.5	21,000	70	1,000	2-0-0 ^b
R-152a	CH ₃ CHF ₂	1,1-difluoroethane	A2	2.0	12,000	32	1,000	1-4-0
R-170	CH ₃ CH ₃	ethane	A3	0.54	7,000	8.7	1,000	2-4-0
R-E170	CH ₃ OCH ₃	Methoxymethane (dimethyl ether)	A3	1.0	8,500	16	1,000	—
R-218	CF ₃ CF ₂ CF ₃	octafluoropropane	A1	43	90,000	690	1,000	2-0-0 ^b
R-227ea	CF ₃ CHFCF ₃	1,1,1,2,3,3,3-heptafluoropropane	A1	36	84,000	580	1,000	—
R-236fa	CF ₃ CH ₂ CF ₃	1,1,1,3,3,3-hexafluoropropane	A1	21	55,000	340	1,000	2-0-0 ^b
R-245fa	CHF ₂ CH ₂ CF ₃	1,1,1,3,3-pentafluoropropane	B1	12	34,000	190	300	2-0-0 ^b
R-290	CH ₃ CH ₂ CH ₃	propane	A3	0.56	5,300	9.5	1,000	2-4-0
R-C318	-(CF ₂) ₄ -	octafluorocyclobutane	A1	41	80,000	660	1,000	—
R-400 ^d	zeotrope	R-12/114 (50.0/50.0)	A1	10	28,000	160	1,000	2-0-0 ^b
R-400 ^d	zeotrope	R-12/114 (60.0/40.0)	A1	11	30,000	170	1,000	—
R-401A	zeotrope	R-22/152a/124 (53.0/13.0/34.0)	A1	6.6	27,000	110	1,000	2-0-0 ^b
R-401B	zeotrope	R-22/152a/124 (61.0/11.0/28.0)	A1	7.2	30,000	120	1,000	2-0-0 ^b
R-401C	zeotrope	R-22/152a/124 (33.0/15.0/52.0)	A1	5.2	20,000	84	1,000	2-0-0 ^b
R-402A	zeotrope	R-125/290/22 (60.0/2.0/38.0)	A1	17	66,000	270	1,000	2-0-0 ^b
R-402B	zeotrope	R-125/290/22 (38.0/2.0/60.0)	A1	15	63,000	240	1,000	2-0-0 ^b
R-403A	zeotrope	R-290/22/218 (5.0/75.0/20.0)	A2	7.6	33,000	120	1,000	2-0-0 ^b
R-403B	zeotrope	R-290/22/218 (5.0/56.0/39.0)	A1	18	70,000	290	1,000	2-0-0 ^b
R-404A	zeotrope	R-125/143a/134a (44.0/52.0/4.0)	A1	31	130,000	500	1,000	2-0-0 ^b

R-405A	zeotrope	R-22/152a/142b/C318 (45.0/7.0/5.5/2.5)	—	16	57,000	260	1,000	—
R-406A	zeotrope	R-22/600a/142b (55.0/4.0/41.0)	A2	4.7	21,000	25	1,000	—
R-407A	zeotrope	R-32/125/134a (20.0/40.0/40.0)	A1	19	83,000	300	1,000	2-0-0 ^B
R-407B	zeotrope	R-32/125/134a (10.0/70.0/20.0)	A1	21	79,000	330	1,000	2-0-0 ^B
R-407C	zeotrope	R-32/125/134a (23.0/25.0/52.0)	A1	18	81,000	290	1,000	2-0-0 ^B
R-407D	zeotrope	R-32/125/134a (15.0/15.0/70.0)	A1	16	68,000	250	1,000	2-0-0 ^B
R-407E	zeotrope	R-32/125/134a (25.0/15.0/60.0)	A1	17	80,000	280	1,000	2-0-0 ^B
R-407F	zeotrope	R-32/125/134a (30.0/30.0/40.0)	A1	20	95,000	320	1,000	—
R-408A	zeotrope	R-125/143a/22 (7.0/46.0/47.0)	A1	21	95,000	340	1,000	2-0-0 ^B
R-409A	zeotrope	R-22/124/142b (60.0/25.0/15.0)	A1	7.1	29,000	110	1,000	2-0-0 ^B
R-409B	zeotrope	R-22/124/142b (65.0/25.0/10.0)	A1	7.3	30,000	120	1,000	2-0-0 ^B
R-410A	zeotrope	R-32/125 (50.0/50.0)	A1	26	140,000	420	1,000	2-0-0 ^B
R-410B	zeotrope	R-32/125 (45.0/55.0)	A1	27	140,000	430	1,000	2-0-0 ^B
R-411A	zeotrope	R-127/22/152a (1.5/87.5/11.0)	A2	2.9	14,000	46	990	—
R-411B	zeotrope	R-1270/22/152a (3.0/94.0/3.0)	A2	2.8	13,000	45	980	—
R-412A	zeotrope	R-22/218/142b (70.0/5.0/25.0)	A2	5.1	22,000	82	1,000	—
R-413A	zeotrope	R-218/134a/600a (9.0/88.0/3.0)	A2	5.8	22,000	94	1,000	—
R-414A	zeotrope	R-22/124/600a/142b (51.0/28.5/4.0/16.5)	A1	6.4	26,000	100	1,000	—
R-414B	zeotrope	R-22/124/600a/142b (50.0/39.0/1.5/9.5)	A1	6.0	23,000	95	1,000	—
R-415A	zeotrope	R-22/152a (82.0/18.0)	A2	2.9	14,000	47	1,000	—
R-415B	zeotrope	R-22/152a (25.0/75.0)	A2	2.1	12,000	34	1,000	—
R-416A	zeotrope	R-134a/124/600 (59.0/39.5/1.5)	A1	3.9	14,000	62	1,000	2-0-0 ^B
R-417A	zeotrope	R-125/134a/600 (46.6/50.0/3.4)	A1	3.5	13,000	56	1,000	2-0-0 ^B
R-417B	zeotrope	R-125/134a/600 (79.0/18.3/2.7)	A1	4.3	15,000	70	1,000	—
R-417C	zeotrope	R-125/134a/600 (19.5/78.8/1.7)	A1	5.4	21,000	87	1,000	—
R-418A	zeotrope	R-290/22/152a (1.5/96.0/2.5)	A2	4.8	22,000	77	1,000	—
R-419A	zeotrope	R-125/134a/E170 (77.0/19.0/4.0)	A2	4.2	15,000	67	1,000	—
R-419B	zeotrope	R-125/134a/E170 (48.5/48.0/3.5)	A2	4.6	17,000	74	1,000	—
R-420A	zeotrope	R-134a/142b (88.0/12.0)	A1	12	45,000	190	1,000	2-0-0 ^B
R-421A	zeotrope	R-125/134a (58.0/42.0)	A1	17	61,000	280	1,000	2-0-0 ^B
R-421B	zeotrope	R-125/134a (85.0/15.0)	A1	21	69,000	330	1,000	2-0-0 ^B
R-422A	zeotrope	R-125/134a/600a (85.1/11.5/3.4)	A1	18	63,000	290	1,000	2-0-0 ^B
R-422B	zeotrope	R-125/134a/600a (55.0/42.0/3.0)	A1	16	56,000	250	1,000	2-0-0 ^B
R-422C	zeotrope	R-125/134a/600a (82.0/15.0/3.0)	A1	18	62,000	290	1,000	2-0-0 ^B
R-422D	zeotrope	R-125/134a/600a (65.1/31.5/3.4)	A1	16	58,000	260	1,000	2-0-0 ^B
R-422E	zeotrope	R-125/134a/600a (58.0/39.3/2.7)	A1	16	57,000	260	1,000	—
R-423A	zeotrope	R-134a/227ea (52.5/47.5)	A1	19	59,000	310	1,000	2-0-0 ^C
R-424A	zeotrope	R-125/134a/600a/600/601a (50.5/47.0/0.9/1.0/0.6)	A1	6.2	23,000	100	970	2-0-0 ^B
R-425A	zeotrope	R-32/134a/227ea (18.5/69.5/12.0)	A1	16	72,000	260	1,000	2-0-0 ^B
R-426A	zeotrope	R-125/134a/600a/601a (5.1/93.0/1.3/0.6)	A1	5.2	20,000	83	990	—
R-427A	zeotrope	R-32/125/143a/134a (15.0/25.0/10.0/50.0)	A1	18	79,000	290	1,000	2-1-0
R-428A	zeotrope	R-125/143a/290/600a (77.5/20.0/0.6/1.9)	A1	23	83,000	370	1,000	—

R-429A	zeotrope	R-E170/152a/600a (60.0/10.0/30.0)	A3	0.81	6,300	13	1,000	—
R-430A	zeotrope	R-152a/600a (76.0/24.0)	A3	1.3	8,000	21	1,000	—
R-431A	zeotrope	R-290/152a (71.0/29.0)	A3	0.69	5,500	11	1,000	—
R-432A	zeotrope	R-1270/E170 (80.0/20.0)	A3	0.13	1,200	2.1	700	—
R-433A	zeotrope	R-1270/290 (30.0/70.0)	A3	0.34	3,100	5.5	880	—
R-433B	zeotrope	R-1270/290 (5.0-95.0)	A3	0.51	4,500	8.1	950	—
R-433C	zeotrope	R-1270/290 (25.0-75.0)	A3	0.41	3,600	6.6	790	—
R-434A	zeotrope	R-125/134a/600a (63.2/18.0/16.0/2.8)	A1	20	73,000	320	1,000	—
R-435A	zeotrope	R-E170/152a (80.0/20.0)	A3	1.1	8,500	17	1,000	—
R-436A	zeotrope	R-290/600a (56.0/44.0)	A3	0.50	4,000	8.1	1,000	—
R-436B	zeotrope	R-290/600a (52.0/48.0)	A3	0.51	4,000	8.1	1,000	—
R-437A	zeotrope	R-125/134a/600/601 (19.5/78.5/1.4/0.6)	A1	5.0	19,000	82	990	—
R-438A	zeotrope	R-32/125/134a/600/601a (8.5/45.0/44.2/1.7/0.6)	A1	4.9	20,000	79	990	—
R-439A	zeotrope	R-32/125/600a (50.0/47.0/3.0)	A2	4.7	26,000	76	990	—
R-440A	zeotrope	R-290/134a/152a (0.6/1.6/97.8)	A2	1.9	12,000	31	1,000	—
R-441A	zeotrope	R-170/290/600a/600 (3.1/54.8/6.0/36.1)	A3	0.39	3,200	6.3	1,000	—
R-442A	zeotrope	R-32/125/134a/152a/227ea (31.0/31.0/30.0/3.0/5.0)	A1	21	100,000	330	1,000	—
R-443A	zeotrope	R-1270/290/600a (55.0/40.0/5.0)	A3	0.19	1,700	3.1	580	—
R-444A	zeotrope	R-32/152a/1234ze(E) (12.0/5.0/83.0)	A2L A2 ⁺	5.1	21,000	81	850	—
R-444B	zeotrope	R-32/152a/1234ze(E) (41.5/10.0/48.5)	A2L A2 ⁺	4.3	23,000	69	890	—
R-445A	zeotrope	R-744/134a/1234ze(E) (6.0/9.0/85.0)	A2L A2 ⁺	4.2	16,000	67	930	—
R-446A	zeotrope	R-32/1234ze(E)/600 (68.0/29.0/3.0)	A2L A2 ⁺	2.5	16,000	39	960	—
R-447A	zeotrope	R-32/125/1234ze(E) (68.0/3.5/28.5)	A2L A2 ⁺	2.6	16,000	42	900	—
R-448A	zeotrope	R-32/125/1234yf/134a/1234ze(E) (26.0/26.0/20.0/21.0/7.0)	A1	24	110,000	390	890	—
R-449A	zeotrope	R-32/125/1234yf/134a (24.3/24.7/25.3/25.7)	A1	23	100,000	370	830	—
R-450A	zeotrope	R-134a/1234ze(E) (42.0/58.0)	A1	20	72,000	320	880	—
R-451A	zeotrope	R-1234yf/134a (89.8/10.2)	A2L A2 ⁺	5.3	18,000	81	520	—
R-451B	zeotrope	R-1234yf/134a (88.8/11.2)	A2L A2 ⁺	5.3	18,000	81	530	—
R-452A	zeotrope	R-32/125/1234yf (11.0/59.0/30.0)	A1	27	100,000	440	780	—
R-500 ^e	azeotrope	R-12/152a (73.8/26.2)	A1	7.6	30,000	120	1,000	2-0-0 ^b
R-501 ^d	azeotrope	R-22/12 (75.0/25.0)	A1	13	54,000	210	1,000	—
R-502 ^e	azeotrope	R-22/115 (48.8/51.2)	A1	21	73,000	330	1,000	2-0-0 ^b
R-503 ^e	azeotrope	R-23/13 (40.1/59.9)	—	—	—	—	1,000	2-0-0 ^b
R-504 ^d	azeotrope	R-32/115 (48.2/51.8)	—	28	140,000	450	1,000	—
R-507A	azeotrope	R-125/134a (50.0/50.0)	A1	32	130,000	520	1,000	2-0-0 ^b
R-508A	azeotrope	R-23/116 (39.0/61.0)	A1	14	55,000	220	1,000	2-0-0 ^b
R-508B	azeotrope	R-23/116 (46.0/54.0)	A1	13	52,000	200	1,000	2-0-0 ^b
R-509A	azeotrope	R-22/218 (44.0/56.0)	A1	24	75,000	390	1,000	2-0-0 ^b
R-510A	azeotrope	R-E170/600a (88.0/12.0)	A3	0.87	7,300	14	1,000	—
R-511A	azeotrope	R-290/E170 (95.0/5.0)	A3	0.59	5,300	9.5	1,000	—
R-512A	azeotrope	R-134a/152a (5.0/95.0)	A2	1.9	11,000	31	1,000	—
R-513A	azeotrope	R-1234yf/134a (56.0/44.0)	A1	20	72,000	320	650	—
R-600	CH ₃ CH ₂ CH ₂ CH ₃	butane	A3	0.15	1,000	2.4	1,000	1-4-0
R-600a	CH(CH ₃) ₂ CH ₃	2-methylpropane (isobutane)	A3	0.59	4,000	9.6	1,000	2-4-0
R-601	CH ₃ CH ₂ CH ₂ CH ₂ CH ₃	pentane	A3	0.18	1,000	2.9	600	—
R-601a	(CH ₃) ₂ CHCH ₂ CH ₃	2-methylbutane (isopentane)	A3	0.18	1,000	2.9	600	—
R-610	ethoxyethane (ethyl ether)	CH ₃ CH ₂ OCH ₂ CH ₃	—	—	—	—	400	—
R-611	methyl formate	HCOOCH ₃	B2	—	—	—	100	—

R-717	NH ₃	ammonia	B2L, B2f	0.014	320	0.22	25	3-3-0 ^c
R-718	H ₂ O	water	A1	—	—	—	—	0-0-0
R-744	CO ₂	carbon dioxide	A1	4.5	40,000	72	5,000	2-0-0 ^b
R-1150	CH ₂ =CH ₂	ethene (ethylene)	A3	—	—	—	200	1-4-2
R-1233zd(E)	CF ₃ CH=CHCl	trans-1-chloro-3,3,3-trifluoro-1-propene	A1	5.3	16,000	85	800	—
R-1234yf	CF ₃ CF=CH ₂	2,3,3,3-tetrafluoro-1 propene	A2L, A2f	4.7	16,000	75	500	—
R-1234ze(E)	CF ₃ CH=CHF	trans-1,3,3,3-tetrafluoro-1-propene	A2L, A2f	4.7	16,000	75	800	—
R-1270	CH ₃ CH=CH ₂	Propene (propylene)	A3	0.1	1,000	1.7	500	1-4-1

For SI: 1 pound = 0.454 kg, 1 cubic foot = 0.0283m³

- a. Degrees of hazard are for health, fire, and reactivity, respectively, in accordance with NFPA 704.
- b. Reduction to 1-0-0 is allowed if analysis satisfactory to the code official shows that the maximum concentration for a rupture or full loss of refrigerant charge would not exceed the IDLH, considering both the refrigerant quantity and room volume.
- c. For installations that are entirely outdoors, use 3-1-0.
- d. Class I ozone depleting substance; prohibited for new installations.
- e. Occupational Exposure Limit based on the OSHA PEL, ACGIH TLV-TWA, the TERA WEEL or consistent value on a time-weighted average (TWA) basis (unless noted C for ceiling) for an 8 hr/d and 40 hr/wk. ~~The ASHRAE Standard 34 flammability classification for this refrigerant is 2L, which is a subclass of Class 2.~~

SECTION 1104 SYSTEM APPLICATION REQUIREMENTS

1104.3 Refrigerant restrictions. Refrigerant applications, maximum quantities and use shall be restricted in accordance with Sections 1104.3.1 through 1104.3.4.

1104.3.1 Air-conditioning for human comfort. In other than industrial occupancies where the quantity in a single independent circuit does not exceed the amount in Table 1103.1, Group B1, B2, ~~B2L~~ and B3 refrigerants shall not be used in high-probability systems for air-conditioning for human comfort. Refrigerating systems containing Group A2L refrigerants shall comply with Section 1104.3.1.1.

Add new text as follows:

1104.3.1.1 Group A2L Refrigerants. High-probability systems using Group A2L refrigerants for human comfort applications shall comply with Sections 1104.3.1.1.1 through 1104.3.1.1.4. Nonoccupiable spaces with refrigerant containing equipment, including piping, shall comply with the amounts indicated in Table 1103.1, except as permitted by Section 1104.3.1.1.3.

1104.3.1.1.1 Listing and Installation Requirements. Where required per Section 1104.3.1.1, refrigerating systems shall be listed, labeled, and installed in accordance with the manufacturer's instructions, and any markings on the equipment restricting the installation. The nameplate shall include a symbol indicating that a flammable refrigerant is used, as specified by the product listing. A label indicating that a flammable refrigerant is used shall be placed adjacent to service ports and other locations where service involving components containing refrigerant is performed, as specified by the product listing.

A refrigerant detector shall be provided in accordance with Section 1104.3.1.1.4 where one or more of the following conditions are met:

1. For Commercial, Public Assembly and Large Mercantile occupancies where the refrigerant charge of any independent circuit exceeds 22 lb (10 kg).
2. For Institutional and Residential occupancies where the refrigerant charge of any independent circuit exceeds 6.6 lb (3 kg).
3. Where using the provisions of Section 1104.3.1.1.3.
4. Where a refrigerant detector is required by the product listing.

When the refrigerant detector senses a rise in refrigerant concentration above the value specified in Section 1104.3.1.1.4, all of the following shall apply:

1. A minimum flow rate of supply air shall be provided in accordance with the following equation: $Q \geq 1001 \times M / \text{LFL}$, (for SI: $Q \geq 60000 \times M / \text{LFL}$), where Q is the supply air flow rate ft³/min (m³/h), M is the refrigerant charge lb (kg), and LFL is the lower flammability limit lb per 1000 ft³ (g/m³).
2. The compressor and all other electrical devices shall be turned off, excluding the control power transformers, control systems, and the supply air fan. The supply air fan shall continue to operate for not less than 5 minutes after the refrigerant detector has sensed a drop in the refrigerant concentration below the value specified in Section 1104.3.1.1.4.
3. Any device that controls air flow located within the product or in duct work that supplies air to the

occupied space shall be fully opened. Any device that controls air flow shall be listed.

4. Heaters and electrical devices located in the ductwork shall be turned off

1104.3.1.1.2 Ignition Sources. Open flame-producing devices shall not be permanently installed in the ductwork that serves the space. Continuously operating hot surfaces exceeding 1292°F (700°C) shall not be located within the ductwork that serves the space. Unclassified electrical devices shall not be located within the ductwork that serves the space.

1104.3.1.1.3 Refrigerant Containing Equipment Located Indoors. For refrigeration compressors and pressure vessels located in an indoor space that is accessible only during service and maintenance it shall be permissible to exceed the amounts indicated in Table 1103.1 where all of the following conditions apply:

Exceptions:

1. The largest single circuit charge does not exceed 6.6 lb (3 kg) for Residential and Institutional occupancies, and does not exceed 22 lb (10 kg) for C
2. The space where compressors and pressure vessels are located is provided with an air distribution system in accordance with the following equation: $Q \geq 1001 \times M / LFL$, (for SI: $Q \geq 60000 \times M / LFL$), where Q is the supply air flow rate ft³/min (m³/h), M is the refrigerant charge lb (kg), and LFL is the lower flammable limit lb per 1000 ft³ (g/m³).
3. Exhaust air is removed from the air distribution system at a minimum rate of 4 air changes per hour and the system has provisions for makeup air. Exhaust air that is removed from the air distribution system is either discharged outside of the building envelope, or discharged to an indoor space, provided that the refrigerant concentration will not exceed the amount indicated in Table 1103.1.
4. The air distribution system is started when the refrigerant detector senses refrigerant in accordance with Section 1104.3.1.1.4. The location of the refrigerant detector is in accordance with Section 1104.3.1.1.4. The air distribution system continues to operate for not less than 30 minutes after the refrigerant detector has sensed a drop in the refrigerant concentration below the value specified in Section 1104.3.1.1.4 (1.).
5. The inlet for return air to the air distribution system is located where refrigerant from a leak is expected to accumulate. The inlet elevation is within 12 inches (30 cm) of the lowest elevation in the space where the compressor or pressure vessel is located.
6. In addition to the requirements of Section 1104.3.1.1.2 there are no open flame producing devices or continuously operating hot surfaces exceeding 1292°F (700°C) that are located within space where the equipment is installed.

1104.3.1.1.4 Refrigerant Detectors.

Refrigerant detectors shall comply with all of the following:

1. The refrigerant detector set point to activate the functions required by Section 1104.3.1.1.1 shall be at a value not exceeding 25% of the lower flammable limit (LFL).
2. One or more refrigerant detectors shall be located such that refrigerant will be detected if the refrigerating system is operating, or not operating. For refrigerating systems that are connected to the occupied space through ductwork, refrigerant detectors shall be located within the listed equipment. For refrigerating systems that are directly connected to the occupied space without ductwork, the refrigerant detector shall be located in the equipment, or shall be located in the occupied space at a height of not more than 12 inches (30 cm) above the floor and within a horizontal distance of not more 3.3 ft (1.0 m) with a direct line of sight of the unit.
3. The refrigerant detector as installed, including any sampling tubes, shall cause the functions required by Section 1104.3.1.1.1 within a time not to exceed 10 seconds, after exposure to a refrigerant concentration exceeding 25% of the LFL.
4. The refrigerant detector shall provide a means for automatic operational self-test as provided in the product listing. Use of a refrigerant test gas is not required. If a failure is detected, a trouble alarm shall be activated and the actions required by Section 1104.3.1.1.1 shall be initiated.
5. The refrigerant detector shall be tested during installation to verify the alarm set point and response time as required by Section 1104.3.1.1.4 items 1 and 3. After installation, the refrigerant detector shall be tested to verify the alarm set point and response time annually or at an interval not exceeding the manufacturer's installation instructions, whichever is less.

Reason:

The proposed code changes include technical content based on ASHRAE Standard 34-2016 with Addendum G and ASHRAE Standard 15-2016 with Addendum D. The revisions in these two ASHRAE addenda are dependent and must be correlated as shown in this code change proposal. Upon publication, these addenda will be incorporated into the 2019 editions of ASHRAE 34 and ASHRAE 15.

There was a considerable amount of industry research into the use of flammable refrigerants that occurred in 2016 and 2017, following the announcement in June 2016 of a collaborative research effort between ASHRAE, AHRI, and US DOE. ASHRAE SSPC15 relied upon this body of knowledge in drafting the addenda to the 2016 edition of Standard 15.

The refrigerant safety group classification is an alphabetical/numerical designation that is used to identify both the toxicity and flammability classifications of a given refrigerant. There are two new safety group classifications added to ASHRAE 34: A2L and B2L. Previously 2L was a sub-class of class 2 as an interim measure to implement changes to refrigerant flammability classification into ASHRAE 34 prior to making associated changes to a future edition of ASHRAE 15; but now 2L is a separate class and safety requirements must be revised to distinguish between class 2 and class 2L.

The current definitions of “flammability classification” and “toxicity classification” are improper since both contain mandatory code requirements. The definitions should only define the term, not contain code requirements with the use of the word “shall.” The current definition of refrigerant safety classifications is incorrect due to revisions to ASHRAE 34. The attempt to define the technical requirements of flammability are not correct. ASHRAE 34 goes into extensive requirements as to how to test and classify a refrigerant regarding flammability. The code should leave the technical requirements to ASHRAE 34 which is accomplished in Section 1103.1. The definition only has to identify the meanings of the classification categories. These terms used are found in the body of ASHRAE 34. The addition of “refrigerant” to the term “flammability classification” and “toxicity classification” clarify that the definitions only apply to refrigerants. Flammability and toxicity are terms also used in the ventilation sections of the code. These definitions do not apply to the use of those terms in Chapter 5.

Additional UL standards are added in Section 1101.2, because without product safety standards that include provisions for equipment using Group A2L refrigerants, the proposal would have no means of implementation, since it relies upon the use of listed and labeled equipment. Rapid refrigerant detection of Group A2L flammable refrigerants, and air movement to enable rapid mixing of released refrigerant, are at the core of the requirements presented in this code proposal.

Bibliography:

Addendum G to ASHRAE Standard 34-2016

Addendum D ASHRAE Standard 15-2016

Cost Impact

The code change proposal will not increase or decrease the cost of construction .

While this proposal may introduce new requirements for A2L refrigerants, the type of refrigerant utilized within a building is up to the owner and designer. Therefore this proposal does not necessarily increase the cost of construction.

Internal ID: 1535

M89-18

IMC: TABLE 1103.1

Proponent: Connor Barbaree, representing ASHRAE (cbarbaree@ashrae.org)

2018 International Mechanical Code

Revise as follows:

**TABLE 1103.1
REFRIGERANT CLASSIFICATION, AMOUNT AND OEL**

CHEMICAL REFRIGERANT	FORMULA	CHEMICAL NAME OF BLEND	REFRIGERANT CLASSIFICATION	AMOUNT OF REFRIGERANT PER OCCUPIED SPACE				[F] DEGREES OF HAZARD*
				Pounds per 1,000 cubic feet	ppm	g/m ³	OEL*	
R-11 ^d	CCl ₃ F	trichlorofluoromethane	A1	0.39	1,300	6.2	C1,000	2-0-0 ^b
R-12 ^{ff}	CCl ₂ F ₂	dichlorodifluoromethane	A1	5.6	18,000	90	1,000	2-0-0 ^b
R-13 ^{ff}	CClF ₃	chlorotrifluoromethane	A1	—	—	—	1,000	2-0-0 ^b
R-13B1 ^{ff}	CBrF ₃	bromotrifluoromethane	A1	—	—	—	1,000	2-0-0 ^b
R-14	CF ₄	tetrafluoromethane (carbon tetrafluoride)	A1	25	110,000	400	1,000	2-0-0 ^b
R-22	CHClF ₂	chlorodifluoromethane	A1	13	59,000	210	1,000	2-0-0 ^b
R-23	CHF ₃	trifluoromethane (fluoroform)	A1	7.3	41,000	120	1,000	2-0-0 ^b
R-30	CH ₂ Cl ₂	dichloromethane (methylene chloride)	B1	—	—	—	—	—
R-32	CH ₂ F ₂	difluoromethane (methylene fluoride)	A2 ^f	4.8	36,000	77	1,000	1-4-0
R-40	CH ₃ Cl	chloromethane (methyl chloride)	B2	—	—	—	—	—
R-50	CH ₄	methane	A3	—	—	—	1,000	—
R-113 ^{ff}	CCl ₂ FCClF ₂	1,1,2-trichloro-1,2,2-trifluoroethane	A1	1.2	2,600	20	1,000	2-0-0 ^b
R-114 ^{ff}	CClF ₂ CClF ₂	1,2-dichloro-1,1,2,2-tetrafluoroethane	A1	8.7	20,000	140	1,000	2-0-0 ^b
R-115	CCF ₂ CF ₃	chloropentafluoroethane	A1	47	120,000	760	1,000	—
R-116	CF ₂ CF ₃	hexafluoroethane	A1	34	97,000	550	1,000	1-0-0
R-123	CHCl ₂ CF ₃	2,2-dichloro-1,1,1-trifluoroethane	B1	3.5	9,300	57	50	2-0-0 ^b
R-124	CHClCF ₂	2-chloro-1,1,1,2-tetrafluoroethane	A1	3.5	10,000	56	1,000	2-0-0 ^b
R-125	CHF ₂ CF ₃	pentafluoroethane	A1	23	75,000	370	1,000	2-0-0 ^b
R-134a	CH ₂ FCF ₂	1,1,1,2-tetrafluoroethane	A1	13	50,000	210	1,000	2-0-0 ^b
R-141b	CH ₂ CClF	1,1-dichloro-1-fluoroethane	—	0.78	2,600	12	500	2-1-0
R-142b	CH ₃ CClF ₂	1-chloro-1,1-difluoroethane	A2	5.1	20,000	83	1,000	2-4-0
R-143a	CH ₃ CF ₃	1,1,1-trifluoroethane	A2 ^f	4.5	21,000	70	1,000	2-0-0 ^b
R-152a	CH ₃ CHF ₂	1,1-difluoroethane	A2	2.0	12,000	32	1,000	1-4-0
R-170	CH ₃ CH ₃	ethane	A3	0.54	7,000	8.7	1,000	2-4-0
R-E170	CH ₃ OCH ₃	Methoxymethane (dimethyl ether)	A3	1.0	8,500	16	1,000	—
R-218	CF ₃ CF ₂ CF ₃	octafluoropropane	A1	43	90,000	690	1,000	2-0-0 ^b
R-227ea	CF ₃ CHFCF ₃	1,1,1,2,3,3,3-heptafluoropropane	A1	36	84,000	580	1,000	—
R-236fa	CF ₃ CH ₂ CF ₃	1,1,1,3,3,3-hexafluoropropane	A1	21	55,000	340	1,000	2-0-0 ^b
R-245fa	CHF ₂ CH ₂ CF ₂	1,1,1,3,3-pentafluoropropane	B1	12	34,000	190	300	2-0-0 ^b
R-290	CH ₃ CH ₂ CH ₃	propane	A3	0.56	5,300	9.5	1,000	2-4-0
R-C318	-(CF ₂) ₄ -	octafluorocyclobutane	A1	41	80,000	600	1,000	—
R-400 ^{ff}	zeotrope	R-12/114 (50.0/50.0)	A1	10	28,000	160	1,000	2-0-0 ^b
R-400 ^{ff}	zeotrope	R-12/114 (60.0/40.0)	A1	11	30,000	170	1,000	—
R-403A	zeotrope	R-22/152a/124 (53.0/13.0/34.0)	A1	6.6	27,000	110	1,000	2-0-0 ^b
R-403B	zeotrope	R-22/152a/124 (61.0/11.0/28.0)	A1	7.2	30,000	120	1,000	2-0-0 ^b
R-403C	zeotrope	R-22/152a/124 (33.0/15.0/52.0)	A1	5.2	20,000	84	1,000	2-0-0 ^b
R-402A	zeotrope	R-125/290/22 (60.0/2.0/38.0)	A1	17	66,000	270	1,000	2-0-0 ^b
R-402B	zeotrope	R-125/290/22 (38.0/2.0/60.0)	A1	15	63,000	240	1,000	2-0-0 ^b
R-403A	zeotrope	R-290/22/218 (5.0/75.0/20.0)	A2	7.6	33,000	120	1,000	2-0-0 ^b
R-403B	zeotrope	R-290/22/218 (5.0/56.0/39.0)	A1	18	70,000	290	1,000	2-0-0 ^b
R-404A	zeotrope	R-125/143a/134a (44.0/52.0/4.0)	A1	31	130,000	500	1,000	2-0-0 ^b
R-405A	zeotrope	R-22/152a/142b/C318 (45.0/7.0/5.5/2.5)	—	16	57,000	260	1,000	—
R-406A	zeotrope	R-22/600a/142b (55.0/4.0/41.0)	A2	4.7	21,000	25	1,000	—
R-407A	zeotrope	R-32/125/134a (20.0/40.0/40.0)	A1	19	81,000	300	1,000	2-0-0 ^b
R-407B	zeotrope	R-32/125/134a (30.0/70.0/0.0)	A1	21	79,000	330	1,000	2-0-0 ^b
R-407C	zeotrope	R-32/125/134a (23.0/25.0/52.0)	A1	18	81,000	290	1,000	2-0-0 ^b
R-407D	zeotrope	R-32/125/134a (15.0/15.0/70.0)	A1	16	68,000	250	1,000	2-0-0 ^b
R-407E	zeotrope	R-32/125/134a (25.0/15.0/60.0)	A1	17	80,000	280	1,000	2-0-0 ^b
R-407F	zeotrope	R-32/125/134a	A1	30	95,000	430	1,000	—

		[30.0/30.0/40.0]						
R-407G	zeolite	R-32/125/134a(1.5/2.5/95.0)	A1	1.3	52,000	210	1,000	-
R-407H	zeolite	R-32/125/134a [32.5/15.0/52.5]	A1	1.9	92,000	300	1,000	-
R-408A	zeolite	R-125/143a/22 (7.0/46.0/47.0)	A1	2.1	95,000	340	1,000	2-0-0 ^b
R-409A	zeolite	R-22/124/142b (60.0/25.0/15.0)	A1	7.1	29,000	110	1,000	2-0-0 ^b
R-409B	zeolite	R-22/124/142b (65.0/25.0/10.0)	A1	7.3	30,000	120	1,000	2-0-0 ^b
R-410A	zeolite	R-32/125 (50.0/50.0)	A1	26	140,000	420	1,000	2-0-0 ^b
R-410B	zeolite	R-32/125 (45.0/55.0)	A1	27	140,000	430	1,000	2-0-0 ^b
R-411A	zeolite	R-127/22/152a (1.5/87.5/11.0)	A2	2.9	14,000	46	990	-
R-411B	zeolite	R-127/22/152a (3.0/94.0/3.0)	A2	2.8	13,000	45	980	-
R-412A	zeolite	R-22/218/142b (70.0/5.0/25.0)	A2	5.1	22,000	82	1,000	-
R-413A	zeolite	R-218/134a/600a (9.0/98.0/3.0)	A2	5.8	22,000	94	1,000	-
R-414A	zeolite	R-22/124/600a/142b (51.0/28.5/4.0/16.5)	A1	6.4	26,000	100	1,000	-
R-414B	zeolite	R-22/124/600a/142b (50.0/39.0/1.5/9.5)	A1	6.0	23,000	95	1,000	-
R-415A	zeolite	R-22/152a (82.0/18.0)	A2	2.9	14,000	47	1,000	-
R-415B	zeolite	R-22/152a (25.0/75.0)	A2	2.1	12,000	34	1,000	-
R-416A	zeolite	R-134a/124/600 (59.0/39.5/1.5)	A1	3.9	14,000	62	1,000	2-0-0 ^b
R-417A	zeolite	R-125/134a/600 (46.6/50.0/3.4)	A1	3.5	13,000	56	1,000	2-0-0 ^b
R-417B	zeolite	R-125/134a/600 (79.0/18.3/2.7)	A1	4.3	15,000	70	1,000	-
R-417C	zeolite	R-125/134a/600 (19.5/78.8/1.7)	A1	5.4	21,000	87	1,000	-
R-418A	zeolite	R-290/22/152a (1.5/96.0/2.5)	A2	4.8	22,000	77	1,000	-
R-419A	zeolite	R-125/134a/E170 (77.0/19.0/4.0)	A2	4.2	15,000	67	1,000	-
R-419B	zeolite	R-125/134a/E170 (48.5/48.0/3.5)	A2	4.6	17,000	74	1,000	-
R-420A	zeolite	R-134a/142b (88.0/12.0)	A1	1.2	45,000	190	1,000	2-0-0 ^b
R-421A	zeolite	R-125/134a (58.0/42.0)	A1	1.7	61,000	280	1,000	2-0-0 ^b
R-421B	zeolite	R-125/134a (85.0/15.0)	A1	2.1	69,000	330	1,000	2-0-0 ^b
R-422A	zeolite	R-125/134a/600a (85.1/11.5/3.4)	A1	1.6	63,000	290	1,000	2-0-0 ^b
R-422B	zeolite	R-125/134a/600a (55.0/42.0/3.0)	A1	1.6	56,000	250	1,000	2-0-0 ^b
R-422C	zeolite	R-125/134a/600a (87.0/15.0/3.0)	A1	1.8	62,000	290	1,000	2-0-0 ^b
R-422D	zeolite	R-125/134a/600a (65.1/31.5/3.4)	A1	1.6	58,000	260	1,000	2-0-0 ^b
R-422E	zeolite	R-125/134a/600a (58.0/39.3/2.7)	A1	1.6	57,000	260	1,000	-
R-423A	zeolite	R-134a/227ea (52.5/47.5)	A1	1.9	59,000	310	1,000	2-0-0 ^c
R-424A	zeolite	R-125/134a/600a/600/601a (50.5/47.0/0.9/1.0/0.6)	A1	6.2	23,000	100	970	2-0-0 ^b
R-425A	zeolite	R-32/134a/227ea (38.5/69.5/12.0)	A1	1.6	72,000	260	1,000	2-0-0 ^b
R-426A	zeolite	R-125/134a/600a/601a (5.1/93.0/1.3/0.6)	A1	5.2	20,000	83	990	-
R-427A	zeolite	R-32/125/143a/134a (15.0/25.0/10.0/50.0)	A1	1.8	79,000	290	1,000	2-1-0
R-428A	zeolite	R-125/143a/290/600a (77.5/20.0/0.6/1.9)	A1	2.3	83,000	370	1,000	-
R-429A	zeolite	R-E170/152a/600a (60.0/10.0/30.0)	A3	0.81	6,300	13	1,000	-
R-430A	zeolite	R-152a/600a (76.0/24.0)	A3	1.3	8,000	21	1,000	-
R-431A	zeolite	R-290/152a (71.0/29.0)	A3	0.69	5,500	13	1,000	-
R-432A	zeolite	R-127/0/E170 (80.0/20.0)	A3	0.13	1,200	2.1	700	-
R-433A	zeolite	R-127/0/290 (30.0/70.0)	A3	0.34	3,100	5.5	880	-
R-433B	zeolite	R-127/0/290 (5.0-95.0)	A3	0.51	4,500	6.1	950	-
R-433C	zeolite	R-127/0/290 (25.0-75.0)	A3	0.41	3,600	6.6	790	-
R-434A	zeolite	R-125/143a/600a (63.2/18.0/16.0/2.8)	A1	2.0	73,000	320	1,000	-
R-435A	zeolite	R-E170/152a (80.0/20.0)	A3	1.1	8,500	17	1,000	-
R-436A	zeolite	R-290/600a (56.0/44.0)	A3	0.50	4,000	6.1	1,000	-
R-436B	zeolite	R-290/600a (52.0/48.0)	A3	0.51	4,000	6.1	1,000	-
R-437A	zeolite	R-125/134a/600/601 (19.5/78.5/1.4/0.6)	A1	5.0	19,000	82	990	-
R-438A	zeolite	R-32/125/134a/600/601a (8.5/45.0/44.2/1.7/0.6)	A1	4.9	20,000	79	990	-
R-439A	zeolite	R-32/125/600a (30.0/47.0/3.0)	A2	4.7	26,000	76	990	-
R-440A	zeolite	R-290/134a/152a (0.6/1.6/97.8)	A2	1.9	12,000	31	1,000	-

R-441A	zeolite	R-170/290/600a/600 (3.1/54.8/6.0/36.3)	A3	0.39	5,200	6.3	1,000	—
R-442A	zeolite	R-32/125/134a/152a/227ea (31.0/31.0/30.0/31.0/31.0)	A1	21	100,000	330	1,000	—
R-443A	zeolite	R-1270/290/600a (55.0/40.0/5.0)	A3	0.19	1,700	3.1	580	—
R-444A	zeolite	R-32/152a/1234ze(E) (12.0/5.0/83.0)	A2 ^f	5.1	21,000	81	850	—
R-444B	zeolite	R-32/152a/1234ze(E) (41.5/10.0/48.5)	A2 ^f	4.3	23,000	69	850	—
R-445A	zeolite	R-744/134a/1234ze(E) (6.0/9.0/85.0)	A2 ^f	4.2	16,000	67	930	—
R-446A	zeolite	R-32/1234ze(E)/600 (58.0/29.0/3.0)	A2 ^f	2.5	16,000	39	960	—
R-447A	zeolite	R-32/125/1234ze(E) (56.0/3.5/26.5)	A2 ^f	2.6	16,000	42	900	—
R-447B	zeolite	R-32/125/1234ze(E) (58.0/8.0/24.0)	A2 ^f	2.3	30,000	360	970	±
R-448A	zeolite	R-32/125/1234yf/134a/1234ze(E) (26.0/26.0/20.0/21.0/7.0)	A1	24	110,000	390	890	—
R-449A	zeolite	R-32/125/1234yf/134a (24.3/24.7/25.3/25.7)	A1	2.5	100,000	370	630	—
R-449B	zeolite	R-32/125/1234yf/134a (25.2/24.3/23.2/22.3)	A1	2.3	100,000	370	850	±
R-449C	zeolite	R-32/125/1234yf/134a (20.0/20.0/31.0/29.0)	A1	2.3	98,000	360	800	±
R-450A	zeolite	R-134a/1234ze(E) (42.0/58.0)	A1	20	72,000	320	880	—
R-451A	zeolite	R-1234yf/134a (89.8/10.2)	A2 ^f	5.3	18,000	61	520	—
R-451B	zeolite	R-1234yf/134a (88.8/11.2)	A2 ^f	5.3	18,000	61	530	—
R-452A	zeolite	R-32/125/1234yf (11.0/59.0/30.0)	A1	27	100,000 10,000	440	780	—
R-452B	zeolite	R-32/125/1234yf (67.0/7.0/26.0)	A2 ^f	2.3	30,000	360	870	±
R-452C	zeolite	R-32/125/1234yf (12.5/61.0/26.5)	A1	27	100,000	430	800	±
R-453A	zeolite	R-32/125/134a/227ea/600/600a (20.0/20.0/33.8/5.0/0.6/0.6)	A1	7.8	34,000	120	1,000	±
R-454A	zeolite	R-32/1234yf (35.0/65.0)	A2 ^f	28	16,000	450	890	±
R-454B	zeolite	R-32/1234yf (68.9/31.1)	A2 ^f	22	19,000	360	850	±
R-454C	zeolite	R-32/1234yf (21.5/78.5)	A2 ^f	29	19,000	660	620	±
R-455A	zeolite	R-744/32/1234yf (3.0/21.5/73.5)	A2 ^f	2.3	30,000	380	850	±
R-456A	zeolite	R-32/134a/1234ze(E) (6.0/45.0/49.0)	A1	20	77,000	320	900	±
R-457A	zeolite	R-32/1234yf/152a (18.0/70.0/12.0)	A2 ^f	25	15,000	600	650	±
R-458A	zeolite	R-32/125/134a/227ea/236fa (20.5/4.0/61.4/13.5/0.6)	A1	16	76,000	280	1,000	±
R-459A	zeolite	R-32/1234yf/1234ze(E) (58.0/26.0/6.0)	A2 ^f	2.3	27,000	360	870	±
R-459B	zeolite	R-32/1234yf/1234ze(E) (21.0/69.0/10.0)	A2 ^f	30	16,000	470	640	±
R-460A	zeolite	R-32/125/134a/1234ze(E) (12.0/52.0/34.0/22.0)	A1	24	92,000	380	850	±
R-460B	zeolite	R-32/125/134a/1234ze(E) (28.0/25.0/20.0/27.0)	A1	25	120,000	600	850	±
R-461A	zeolite	R-125/143a/134a/227ea/600a (55.0/5.0/32.0/5.0/3.0)	A1	17	61,000	270	1,000	±
R-462A	zeolite	R-32/125/143a/134a/600 (9.0/42.0/2.0/44.0/3.0)	A2	3.9	16,000	62	1,000	±
R-500 ^c	azeotrope	R-12/152a (73.8/26.2)	A1	7.6	30,000	120	1,000	2-0-0 ^b
R-501 ^d	azeotrope	R-22/32 (75.0/25.0)	A1	1.3	94,000	210	1,000	—
R-502 ^e	azeotrope	R-22/135 (48.6/51.2)	A1	21	73,000	330	1,000	2-0-0 ^b
R-503 ^f	azeotrope	R-23/13 (40.1/59.9)	—	—	—	—	1,000	2-0-0 ^b
R-504 ^g	azeotrope	R-32/135 (48.2/51.8)	—	—	140,000	450	1,000	—
R-507A	azeotrope	R-125/143a (50.0/50.0)	A1	32	130,000	520	1,000	2-0-0 ^b
R-508A	azeotrope	R-23/136 (39.0/61.0)	A1	14	55,000	220	1,000	2-0-0 ^b
R-508B	azeotrope	R-23/136 (46.0/54.0)	A1	1.3	52,000	200	1,000	2-0-0 ^b
R-509A	azeotrope	R-22/218 (44.0/56.0)	A1	24	75,000	390	1,000	2-0-0 ^b
R-510A	azeotrope	R-E170/600a (88.0/12.0)	A3	0.87	7,300	14	1,000	—
R-511A	azeotrope	R-290/E170 (95.0/5.0)	A3	0.59	5,300	9.5	1,000	—
R-512A	azeotrope	R-134a/152a (5.0/95.0)	A2	1.9	11,000	31	1,000	—
R-513A	azeotrope	R-1234yf/134a (56.0/44.0)	A1	20	72,000	320	650	—
R-513B	azeotrope	R-1234yf/134a (58.3/41.7)	A1	21	74,000	330	640	±
R-514A	azeotrope	R-1336/mze/5/1130(E) (74.7/25.3)	B1	0.88	2,400	24	320	±
R-515A	azeotrope	R-1234ze(E)/227ea (88.0/12.0)	A1	19	62,000	300	810	±
R-516A	azeotrope	R-1234yf/134a/152a (37.8/62.2/0)	A2	7.0	27,000	110	590	±

LFL, UEL, and AEL									
R-600	CH ₃ CH ₂ CH ₂ CH ₃	butane	A3	0.15	1,000	2.4	1,000	1-4-0	
R-600a	CH(CH ₃) ₂ CH ₃	2-methylpropane (isobutane)	A3	0.59	4,000	9.6	1,000	2-4-0	
R-601	CH ₃ CH ₂ CH ₂ CH ₂ CH ₃	pentane	A3	0.18	1,000	2.9	600	—	
R-601a	(CH ₃) ₂ CHCH ₂ CH ₃	2-methylbutane (isopentane)	A3	0.18	1,000	2.9	600	—	
R-610	ethoxyethane (ethyl ether)	CH ₃ CH ₂ OCH ₂ CH ₃	—	—	—	—	400	—	
R-611	methyl formate	HCOOCH ₃	B2	—	—	—	100	—	
R-717	NH ₃	ammonia	B2 ^f	0.014	320	0.22	25	3-3-0 ^c	
R-718	H ₂ O	water	A1	—	—	—	—	0-0-0	
R-744	CO ₂	carbon dioxide	A1	4.5	40,000	72	5,000	2-0-0 ^b	
R-1130(E)	CHCl=CHCl	trans-1,2-dichloroethene	B1	0.25	1,000	4	200	—	
R-1132a	CF ₂ =CH ₂	1,1-difluoroethylene	A2	2.0	13,000	33	500	—	
R-1150	CH ₂ =CH ₂	ethene (ethylene)	A3	—	—	—	200	1-4-2	
R-1224yd(Z)	CF ₃ CF=CHCl	(Z)-1-chloro-2,3,3,3-tetrafluoroethylene	A1	2.2	60,000	360	1,000	—	
R-1233zd(E)	CF ₃ CH=CHCl	trans-1-chloro-3,3,3-trifluoro-1-propene	A1	5.3	16,000	85	800	—	
R-1234yf	CF ₃ CF=CH ₂	2,3,3,3-tetrafluoro-1-propene	A2 ^f	4.7	16,000	75	500	—	
R-1234ze(E)	CF ₃ CH=CHF	trans-1,3,3,3-tetrafluoro-1-propene	A2 ^f	4.7	16,000	75	800	—	
R-1270	CH ₃ CH=CH ₂	Propene (propylene)	A3	0.1	1,000	1.7	500	1-4-1	
R-1336mzz(Z)	CF ₃ CFCHCF ₃	cis-1,1,1,4,4,4-hexafluoro-2-butene	A1	5.4	13,000	87.0	500	—	

For SI: 1 pound = 0.454 kg, 1 cubic foot = 0.0283m³

- a. Degrees of hazard are for health, fire, and reactivity, respectively, in accordance with NFPA 704.
- b. Reduction to 1-0-0 is allowed if analysis satisfactory to the code official shows that the maximum concentration for a rupture or full loss of refrigerant charge would not exceed the IDLH, considering both the refrigerant quantity and room volume.
- c. For installations that are entirely outdoors, use 3-1-0.
- d. Class I ozone depleting substance; prohibited for new installations.
- e. Occupational Exposure Limit based on the OSHA PEL, ACGIH TLV-TWA, the TERA WEEL or consistent value on a time-weighted average (TWA) basis (unless noted C for ceiling) for an 8 hr/d and 40 hr/wk.
- f. The ASHRAE Standard 34 flammability classification for this refrigerant is 2L, which is a subclass of Class 2.

Reason:

The Refrigerant Classifications (except Degrees of Hazard) are determined by ASHRAE SSPC 34 and published in ASHRAE Standard 34. This proposal seeks to update the refrigerant table with the new refrigerants added to Standard 34 since the last code cycle. The reasons for the additions of new refrigerants can be found at <https://www.ashrae.org/standards-research--technology/standards-addenda>. All proposed changes are either incorporated into ASHRAE Standard 34-2016 or the published addenda to ASHRAE Standard 34-2016 located at the link above.

Bibliography:

AHRAE Standard 34-2016

Addenda a, b, c, d, f, w, ak, al, am, an to ASHRAE Standard 34-2016 - <https://www.ashrae.org/standards-research--technology/standards-addenda>

Cost Impact

The code change proposal will not increase or decrease the cost of construction .

Updating the table of refrigerants that could be used in systems does not add labor or material costs because the choice of refrigerant is up to the owner and designer.

Internal ID: 369

M90-18

IMC: 1102.3

Proponent: Guy McMann, representing Colorado Association of Plumbing and Mechanical Officials (CAPMO)
(gmcman@jeffco.us)

2018 International Mechanical Code

Delete without substitution:

~~**1102.3 Access port protection.** Refrigerant access ports shall be protected in accordance with Section 1101.10 whenever refrigerant is added to or recovered from refrigeration or air-conditioning systems.~~

Reason:

This is already covered in Section 1102.3 and is complied with at the building stage. The deleted Section is a maintenance operation that cannot be verified after the inspection process because it won't generate a permit unless specifically adopted by the AHJ. This is better suited to be in the Existing Building Code or the Property Maintenance Code.

Cost Impact

The code change proposal will not increase or decrease the cost of construction .

This proposal is editorial in nature.

Internal ID: 163

M91-18

IMC: 1106.2

Proponent: Jeffrey Shapiro, representing International Institute of Ammonia Refrigeration
(jeff.shapiro@intlcodeconsultants.com)

2018 International Mechanical Code

Revise as follows:

1106.2 Elevated temperature. There shall not be an open flame-producing device or continuously operating hot surface over 800°F (427°C) permanently installed in the room.

Exceptions:

1. Open flame-producing devices shall not be prohibited in machinery rooms for ammonia refrigeration equipment where combustion air is ducted from outside of the machinery room and sealed in such a manner as to prevent any refrigerant leakage from entering the combustion chamber.
2. Open flame-producing devices and continuously operating hot surfaces shall not be prohibited in machinery rooms for ammonia refrigeration equipment where refrigerant leak detection in the machinery room will automatically stop the equipment or process producing an open flame or hot surface when a refrigerant leak is detected.

Reason:

IIAR has separately proposed that Chapter 11 entirely defer to IIAR standards to eliminate overlap and correlation issues. If that proposal is successful, this proposal is unnecessary. However, if the IMC retains requirements that impact ammonia refrigeration, this section needs to be correlated with IIAR 2 for consistency. The technical justification is 1) Sealed combustion chambers do not present a risk of ignition of refrigerant leakage, and 2) Ignition sources that will automatically shut off when a refrigerant leak is detected do not present a hazard for ammonia because ammonia's flammability range begins at about 160,000 ppm (16% in air) and codes requires leak detection to activate ventilation at 1,000 ppm or less.

Cost Impact

The code change proposal will not increase or decrease the cost of construction .

The proposed exceptions provide design options that are not mandatory and therefore do not have a mandatory cost impact.

Internal ID: 2020

M92-18

IMC: 1107.5.4

Proponent: Jay Peters, Codes and Standards International, representing Cerro Flow Copper, RLS LLC
(peters.jay@me.com)

2018 International Mechanical Code

Revise as follows:

1107.5.4 Copper tubing joints. Copper tubing joints used in refrigerating systems containing Group A2, A3, B2 or B3 refrigerants shall be brazed. Soldered joints shall not be used in such refrigerating systems. Press-connect fittings shall be tested in accordance with UL 207.

Reason:

Press-connect fittings used for refrigeration systems are typically tested and listed to meet the requirements in UL 207. This proposal assists inspectors and manufacturers by clarifying the need for certification and the standard by which they are to be listed and tested.

Cost Impact

The code change proposal will not increase or decrease the cost of construction .

Refrigeration fittings are already required to be tested and listed per ASHRAE Standard 15 and the IMC. This proposal just clarifies the proper standard to which they are to be tested and listed.

Internal ID: 2271

M93-18

IMC: 1101.1, 1101.1.1 (New), 1101.1.2 (New), 1101.6, TABLE 1103.1, 1104.2.2, 1104.3.3, 1104.3.4, 1105.6.3, 1105.8, 1105.9, 1106.3, 1106.4, 1108.2

Proponent: Jeffrey Shapiro, representing International Institute of Ammonia Refrigeration
(jeff.shapiro@intlcodeconsultants.com)

2018 International Mechanical Code

Revise as follows:

1101.1 Scope. This chapter shall govern the design, installation, construction and repair of refrigeration systems that vaporize and liquefy a fluid during the refrigerating cycle. ~~Refrigerant piping design and installation, including pressure vessels and pressure relief devices, shall conform to this code.~~ Permanently installed refrigerant storage systems and other components shall be considered as part of the refrigeration system to which they are attached.

Add new text as follows:

1101.1.1 Refrigerants other than ammonia. Refrigerant piping design and installation, including pressure vessels and pressure relief devices, for systems containing a refrigerant other than ammonia shall comply with this chapter and ASHRAE 15.

1101.1.2 Ammonia refrigerant. Refrigeration systems using ammonia as the refrigerant shall comply with IAR 2, IAR 3, IAR 4 and IAR 5, and shall not be required to comply with this chapter.

Delete without substitution:

~~**1101.6 General.** Refrigeration systems shall comply with the requirements of this code and, except as modified by this code, ASHRAE 15. Ammonia refrigerating systems shall comply with this code and, except as modified by this code, ASHRAE 15, IAR 2, IAR 3, IAR 4 and IAR 5.~~

Revise as follows:

TABLE 1103.1

REFRIGERANT CLASSIFICATION, AMOUNT AND OEL

CHEMICAL REFRIGERANT	FORMULA	CHEMICAL NAME OF BLEND	REFRIGERANT CLASSIFICATION	AMOUNT OF REFRIGERANT PER OCCUPIED SPACE				[F] DEGREES OF HAZARD ^a
				Pounds per 1,000 cubic feet	ppm	g/m ³	OEL ^c	
R-11 ^d	CCl ₃ F	trichlorofluoromethane	A1	0.39	1,100	6.2	C1,000	2-0-0 ^b
R-12 ^d	CCl ₂ F ₂	dichlorodifluoromethane	A1	5.6	18,000	90	1,000	2-0-0 ^b
R-13 ^d	CCF ₃	chlorotrifluoromethane	A1	—	—	—	1,000	2-0-0 ^b
R-13B1 ^d	CBrF ₃	bromotrifluoromethane	A1	—	—	—	1,000	2-0-0 ^b
R-14	CF ₄	tetrafluoromethane (carbon tetrafluoride)	A1	25	110,000	400	1,000	2-0-0 ^b
R-22	CHClF ₂	chlorodifluoromethane	A1	13	59,000	210	1,000	2-0-0 ^b
R-23	CHF ₃	trifluoromethane (fluoroform)	A1	7.3	41,000	120	1,000	2-0-0 ^b
R-30	CH ₂ Cl ₂	dichloromethane (methylene chloride)	B1	—	—	—	—	—
R-32	CH ₂ F ₂	difluoromethane (methylene fluoride)	A2 ^c	4.8	36,000	77	1,000	1-4-0
R-40	CH ₃ Cl	chloromethane (methyl chloride)	B2	—	—	—	—	—
R-50	CH ₄	methane	A3	—	—	—	1,000	—
R-113 ^d	CCl ₂ FCClF ₂	1,1,2-trichloro-1,2,2-trifluoroethane	A1	1.2	2,600	20	1,000	2-0-0 ^b
R-114 ^d	CClF ₂ CCF ₂	1,2-dichloro-1,1,2,2-tetrafluoroethane	A1	8.7	20,000	140	1,000	2-0-0 ^b
R-115	CCF ₂ CF ₃	chloropentafluoroethane	A1	47	120,000	760	1,000	—
R-116	CF ₃ CF ₃	hexafluoroethane	A1	34	97,000	550	1,000	1-0-0
R-123	CHCl ₂ CF ₃	2,2-dichloro-1,1,1-trifluoroethane	B1	3.5	9,100	57	50	2-0-0 ^b
R-124	CHClFCF ₃	2-chloro-1,1,1,2-tetrafluoroethane	A1	3.5	10,000	56	1,000	2-0-0 ^b
R-125	CHF ₂ CF ₃	pentafluoroethane	A1	23	75,000	370	1,000	2-0-0 ^b
R-134a	CH ₂ FCF ₃	1,1,1,2-tetrafluoroethane	A1	13	50,000	210	1,000	2-0-0 ^b
R-141b	CH ₃ CCl ₂ F	1,1-dichloro-1-fluoroethane	—	0.78	2,600	12	500	2-1-0
R-142b	CH ₃ CClF ₂	1-chloro-1,1-difluoroethane	A2	5.1	20,000	83	1,000	2-4-0
R-143a	CH ₃ CF ₃	1,1,1-trifluoroethane	A2 ^c	4.5	21,000	70	1,000	2-0-0 ^b
R-152a	CH ₃ CHF ₂	1,1-difluoroethane	A2	2.0	12,000	32	1,000	1-4-0
R-170	CH ₃ CH ₃	ethane	A3	0.54	7,000	8.7	1,000	2-4-0
R-E170	CH ₃ OCH ₃	Methoxymethane (dimethyl ether)	A3	1.0	8,500	16	1,000	—
R-218	CF ₃ CF ₂ CF ₃	octafluoropropane	A1	43	90,000	690	1,000	2-0-0 ^b
R-227ea	CF ₃ CHFCF ₃	1,1,1,2,3,3,3-heptafluoropropane	A1	36	84,000	580	1,000	—
R-236fa	CF ₃ CH ₂ CF ₃	1,1,1,3,3,3-hexafluoropropane	A1	21	55,000	340	1,000	2-0-0 ^b
R-245fa	CHF ₂ CH ₂ CF ₃	1,1,1,3,3-pentafluoropropane	B1	12	34,000	190	300	2-0-0 ^b
R-290	CH ₃ CH ₂ CH ₃	propane	A3	0.56	5,300	9.5	1,000	2-4-0
R-C318	-(CF ₂) ₄ -	octafluorocyclobutane	A1	41	80,000	660	1,000	—
R-400 ^d	zeotrope	R-12/114 (50.0/50.0)	A1	10	28,000	160	1,000	2-0-0 ^b
R-400 ^d	zeotrope	R-12/114 (60.0/40.0)	A1	11	30,000	170	1,000	—
R-401A	zeotrope	R-22/152a/124 (53.0/13.0/34.0)	A1	6.6	27,000	110	1,000	2-0-0 ^b
R-401B	zeotrope	R-22/152a/124 (61.0/11.0/28.0)	A1	7.2	30,000	120	1,000	2-0-0 ^b
R-401C	zeotrope	R-22/152a/124 (33.0/15.0/52.0)	A1	5.2	20,000	84	1,000	2-0-0 ^b
R-402A	zeotrope	R-125/290/22 (60.0/2.0/38.0)	A1	17	66,000	270	1,000	2-0-0 ^b
R-402B	zeotrope	R-125/290/22 (38.0/2.0/60.0)	A1	15	63,000	240	1,000	2-0-0 ^b
R-403A	zeotrope	R-290/22/218 (5.0/75.0/20.0)	A2	7.6	33,000	120	1,000	2-0-0 ^b
R-403B	zeotrope	R-290/22/218 (5.0/56.0/39.0)	A1	18	70,000	290	1,000	2-0-0 ^b
R-404A	zeotrope	R-125/143a/134a (44.0/52.0/4.0)	A1	31	130,000	500	1,000	2-0-0 ^b
R-405A	zeotrope	R-22/152a/142b/C318 (45.0/7.0/5.5/2.5)	—	16	57,000	260	1,000	—
R-406A	zeotrope	R-22/600a/142b (55.0/4.0/41.0)	A2	4.7	21,000	25	1,000	—
R-407A	zeotrope	R-32/125/134a (20.0/40.0/40.0)	A1	19	83,000	300	1,000	2-0-0 ^b

R-407A	zeotrope	R-32/125/134a (20.0/40.0/40.0)	A1	19	83,000	300	1,000	2-0-0 ^B
R-407B	zeotrope	R-32/125/134a (10.0/70.0/20.0)	A1	21	79,000	330	1,000	2-0-0 ^B
R-407C	zeotrope	R-32/125/134a (23.0/25.0/52.0)	A1	18	81,000	290	1,000	2-0-0 ^B
R-407D	zeotrope	R-32/125/134a (15.0/15.0/70.0)	A1	16	68,000	250	1,000	2-0-0 ^B
R-407E	zeotrope	R-32/125/134a (25.0/15.0/60.0)	A1	17	80,000	280	1,000	2-0-0 ^B
R-407F	zeotrope	R-32/125/134a (30.0/30.0/40.0)	A1	20	95,000	320	1,000	—
R-408A	zeotrope	R-125/143a/22 (7.0/46.0/47.0)	A1	21	95,000	340	1,000	2-0-0 ^B
R-409A	zeotrope	R-22/124/142b (60.0/25.0/15.0)	A1	7.1	29,000	110	1,000	2-0-0 ^B
R-409B	zeotrope	R-22/124/142b (65.0/25.0/10.0)	A1	7.3	30,000	120	1,000	2-0-0 ^B
R-410A	zeotrope	R-32/125 (50.0/50.0)	A1	26	140,000	420	1,000	2-0-0 ^B
R-410B	zeotrope	R-32/125 (45.0/55.0)	A1	27	140,000	430	1,000	2-0-0 ^B
R-411A	zeotrope	R-127/22/152a (1.5/87.5/11.0)	A2	2.9	14,000	46	990	—
R-411B	zeotrope	R-1270/22/152a (3.0/94.0/3.0)	A2	2.8	13,000	45	980	—
R-412A	zeotrope	R-22/218/142b (70.0/5.0/25.0)	A2	5.1	22,000	82	1,000	—
R-413A	zeotrope	R-218/134a/600a (9.0/88.0/3.0)	A2	5.8	22,000	94	1,000	—
R-414A	zeotrope	R-22/124/600a/142b (51.0/28.5/4.0/16.5)	A1	6.4	26,000	100	1,000	—
R-414B	zeotrope	R-22/124/600a/142b (50.0/39.0/1.5/9.5)	A1	6.0	23,000	95	1,000	—
R-415A	zeotrope	R-22/152a (82.0/18.0)	A2	2.9	14,000	47	1,000	—
R-415B	zeotrope	R-22/152a (25.0/75.0)	A2	2.1	12,000	34	1,000	—
R-416A	zeotrope	R-134a/124/600 (59.0/39.5/1.5)	A1	3.9	14,000	62	1,000	2-0-0 ^B
R-417A	zeotrope	R-125/134a/600 (46.6/50.0/3.4)	A1	3.5	13,000	56	1,000	2-0-0 ^B
R-417B	zeotrope	R-125/134a/600 (79.0/18.3/2.7)	A1	4.3	15,000	70	1,000	—
R-417C	zeotrope	R-125/134a/600 (19.5/78.8/1.7)	A1	5.4	21,000	87	1,000	—
R-418A	zeotrope	R-290/22/152a (1.5/96.0/2.5)	A2	4.8	22,000	77	1,000	—
R-419A	zeotrope	R-125/134a/E170 (77.0/19.0/4.0)	A2	4.2	15,000	67	1,000	—
R-419B	zeotrope	R-125/134a/E170 (48.5/48.0/3.5)	A2	4.6	17,000	74	1,000	—
R-420A	zeotrope	R-134a/142b (88.0/12.0)	A1	12	45,000	190	1,000	2-0-0 ^B
R-421A	zeotrope	R-125/134a (58.0/42.0)	A1	17	61,000	280	1,000	2-0-0 ^B
R-421B	zeotrope	R-125/134a (85.0/15.0)	A1	21	69,000	330	1,000	2-0-0 ^B
R-422A	zeotrope	R-125/134a/600a (85.1/11.5/3.4)	A1	18	63,000	290	1,000	2-0-0 ^B
R-422B	zeotrope	R-125/134a/600a (55.0/42.0/3.0)	A1	16	56,000	250	1,000	2-0-0 ^B
R-422C	zeotrope	R-125/134a/600a (82.0/15.0/3.0)	A1	18	62,000	290	1,000	2-0-0 ^B
R-422D	zeotrope	R-125/134a/600a (65.1/31.5/3.4)	A1	16	58,000	260	1,000	2-0-0 ^B
R-422E	zeotrope	R-125/134a/600a (58.0/39.3/2.7)	A1	16	57,000	260	1,000	—
R-423A	zeotrope	R-134a/227ea (52.5/47.5)	A1	19	59,000	310	1,000	2-0-0 ^C
R-424A	zeotrope	R-125/134a/600a/600/601a (50.5/47.0/0.9/1.0/0.6)	A1	6.2	23,000	100	970	2-0-0 ^B
R-425A	zeotrope	R-32/134a/227ea (18.5/69.5/12.0)	A1	16	72,000	260	1,000	2-0-0 ^B
R-426A	zeotrope	R-125/134a/600a/601a (5.3/93.0/1.3/0.6)	A1	5.2	20,000	83	990	—
R-427A	zeotrope	R-32/125/143a/134a (15.0/25.0/10.0/50.0)	A1	18	79,000	290	1,000	2-1-0
R-428A	zeotrope	R-125/143a/290/600a (77.5/20.0/0.6/1.9)	A1	23	83,000	370	1,000	—
R-429A	zeotrope	R-E170/152a/600a (60.0/10.0/30.0)	A3	0.81	6,300	13	1,000	—
R-430A	zeotrope	R-152a/600a (76.0/24.0)	A3	1.3	8,000	21	1,000	—
R-431A	zeotrope	R-290/152a (71.0/29.0)	A3	0.69	5,500	11	1,000	—
R-432A	zeotrope	R-1270/E170 (80.0/20.0)	A3	0.13	1,200	2.1	700	—
R-433A	zeotrope	R-1270/290 (30.0/70.0)	A3	0.34	3,100	5.5	880	—

R-433B	zeotrope	R-1270/290 (5.0-95.0)	A3	0.51	4,500	8.1	950	—
R-433C	zeotrope	R-1270/290 (25.0-75.0)	A3	0.41	3,600	6.6	790	—
R-434A	zeotrope	R-125/143a/600a (63.2/18.0/16.0/2.8)	A1	20	73,000	320	1,000	—
R-435A	zeotrope	R-E170/152a (80.0/20.0)	A3	1.1	8,500	17	1,000	—
R-436A	zeotrope	R-290/600a (56.0/44.0)	A3	0.50	4,000	8.1	1,000	—
R-436B	zeotrope	R-290/600a (52.0/48.0)	A3	0.51	4,000	8.1	1,000	—
R-437A	zeotrope	R-125/134a/600/601 (19.5/78.5/1.4/0.6)	A1	5.0	19,000	82	990	—
R-438A	zeotrope	R-32/125/134a/600/601a (8.5/45.0/44.2/1.7/0.6)	A1	4.9	20,000	79	990	—
R-439A	zeotrope	R-32/125/600a (50.0/47.0/3.0)	A2	4.7	26,000	76	990	—
R-440A	zeotrope	R-290/134a/152a (0.6/1.6/97.8)	A2	1.9	12,000	31	1,000	—
R-441A	zeotrope	R-170/290/600a/600 (3.1/54.8/6.0/36.1)	A3	0.39	3,200	6.3	1,000	—
R-442A	zeotrope	R-32/125/134a/152a/227ea (31.0/31.0/30.0/3.0/5.0)	A1	21	100,000	330	1,000	—
R-443A	zeotrope	R-1270/290/600a (55.0/40.0/5.0)	A3	0.19	1,700	3.1	580	—
R-444A	zeotrope	R-32/152a/1234ze(E) (12.0/5.0/83.0)	A2 ^h	5.1	21,000	81	850	—
R-444B	zeotrope	R-32/152a/1234ze(E) (41.5/10.0/48.5)	A2 ^h	4.3	23,000	69	890	—
R-445A	zeotrope	R-744/134a/1234ze(E) (6.0/9.0/85.0)	A2 ^h	4.2	16,000	67	930	—
R-446A	zeotrope	R-32/1234ze(E)/600 (68.0/29.0/3.0)	A2 ^h	2.5	16,000	39	960	—
R-447A	zeotrope	R-32/125/1234ze(E) (68.0/3.5/28.5)	A2 ^h	2.6	16,000	42	900	—
R-448A	zeotrope	R-32/125/1234yf/134a/1234ze(E) (26.0/26.0/20.0/21.0/7.0)	A1	24	110,000	390	890	—
R-449A	zeotrope	R-32/125/1234yf/134a (24.3/24.7/25.3/25.7)	A1	23	100,000	370	830	—
R-450A	zeotrope	R-134a/1234ze(E) (42.0/58.0)	A1	20	72,000	320	880	—
R-451A	zeotrope	R-1234yf/134a (89.8/10.2)	A2 ^h	5.3	18,000	81	520	—
R-451B	zeotrope	R-1234yf/134a (88.8/11.2)	A2 ^h	5.3	18,000	81	530	—
R-452A	zeotrope	R-32/125/1234yf (11.0/59.0/30.0)	A1	27	100,000	440	780	—
R-500 ^a	azeotrope	R-12/152a (73.8/26.2)	A1	7.6	30,000	120	1,000	2-0-0 ^b
R-501 ^d	azeotrope	R-22/32 (75.0/25.0)	A1	13	54,000	210	1,000	—
R-502 ^e	azeotrope	R-22/115 (48.8/51.2)	A1	21	73,000	330	1,000	2-0-0 ^b
R-503 ^e	azeotrope	R-23/13 (40.1/59.9)	—	—	—	—	1,000	2-0-0 ^b
R-504 ^d	azeotrope	R-32/115 (48.2/51.8)	—	28	140,000	450	1,000	—
R-507A	azeotrope	R-125/143a (50.0/50.0)	A1	32	130,000	520	1,000	2-0-0 ^b
R-508A	azeotrope	R-23/116 (39.0/61.0)	A1	14	55,000	220	1,000	2-0-0 ^b
R-508B	azeotrope	R-23/116 (46.0/54.0)	A1	13	52,000	200	1,000	2-0-0 ^b
R-509A	azeotrope	R-22/218 (44.0/56.0)	A1	24	75,000	390	1,000	2-0-0 ^b
R-510A	azeotrope	R-E170/600a (88.0/12.0)	A3	0.87	7,300	14	1,000	—
R-511A	azeotrope	R-290/E170 (95.0/5.0)	A3	0.59	5,300	9.5	1,000	—
R-512A	azeotrope	R-134a/152a (5.0/95.0)	A2	1.9	11,000	31	1,000	—
R-513A	azeotrope	R-1234yf/134a (56.0/44.0)	A1	20	72,000	320	650	—
R-600	CH ₃ CH ₂ CH ₂ CH ₃	butane	A3	0.15	1,000	2.4	1,000	1-4-0
R-600a	CH(CH ₃) ₂ CH ₃	2-methylpropane (isobutane)	A3	0.59	4,000	9.6	1,000	2-4-0
R-601	CH ₃ CH ₂ CH ₂ CH ₂ CH ₃	pentane	A3	0.18	1,000	2.9	600	—
R-601a	(CH ₃) ₂ CHCH ₂ CH ₃	2-methylbutane (isopentane)	A3	0.18	1,000	2.9	600	—
R-610	ethoxyethane (ethyl ether)	CH ₃ CH ₂ OCH ₂ CH ₃	—	—	—	—	400	—
R-611	methyl formate	HCOOCH ₃	B2	—	—	—	100	—
R-717	NH ₃	ammonia	B2 ^h	0.014	320	0.22	25	3-3-0 ^b
R-718	H ₂ O	water	A1	—	—	—	—	0-0-0
R-744	CO ₂	carbon dioxide	A1	4.5	40,000	72	5,000	2-0-0 ^b
R-1150	CH ₂ =CH ₂	ethene (ethylene)	A3	—	—	—	200	1-4-2
R-1233zd(E)	CF ₃ CH=CHCl	trans-1-chloro-3,3,3-trifluoro-1-propene	A1	5.3	16,000	85	800	—
R-1234yf	CF ₃ CF=CH ₂	2,3,3,3-tetrafluoro-1 propene	A2 ^h	4.7	16,000	75	500	—
R-1234ze(E)	CF ₃ CH=CHF	trans-1,3,3,3-tetrafluoro-1-propene	A2 ^h	4.7	16,000	75	800	—
R-1270	CH ₃ CH=CH ₂	Propene (propylene)	A3	0.1	1,000	1.7	500	1-4-1

For SI: 1 pound = 0.454 kg, 1 cubic foot = 0.0283m³

- a. Degrees of hazard are for health, fire, and reactivity, respectively, in accordance with NFPA 704.
- b. Reduction to 1-0-0 is allowed if analysis satisfactory to the code official shows that the maximum concentration for a rupture or full loss of refrigerant charge would not exceed the IDLH, considering both the refrigerant quantity and room volume.
- c. ~~For installations that are entirely outdoors, use 3-1-0.~~ The ASHRAE Standard 34 flammability classification for this refrigerant is 2L, which is a subclass of Class 2.
- d. Class I ozone depleting substance; prohibited for new installations.
- e. Occupational Exposure Limit based on the OSHA PEL, ACGIH TLV-TWA, the TERA WEEL or consistent value on a time-weighted average (TWA) basis (unless noted C for ceiling) for an 8 hr/d and 40 hr/wk.
- f. ~~The ASHRAE Standard 34 flammability classification for this refrigerant is 2L, which is a subclass of Class 2.~~

1104.2.2 Industrial occupancies and refrigerated rooms. This section applies only to rooms and spaces that: are within industrial occupancies; contain a refrigerant evaporator; are maintained at temperatures below 68°F (20°C); and are used for manufacturing, food and beverage preparation, meat cutting, other processes and storage. Where a machinery room would otherwise be required by Section 1104.2, a machinery room shall not be required where all of the following conditions are met:

1. The space containing the machinery is separated from other occupancies by tight construction with tight-fitting doors.
2. Access is restricted to authorized personnel.
3. Refrigerant detectors are installed as required for machinery rooms in accordance with Section 1105.3.

Exceptions Exception:

- ~~1. Refrigerant detectors are not required in unoccupied areas that contain only continuous piping that does not include valves, valve assemblies, equipment, or equipment connections.~~
- ~~2. Where approved alternatives are provided, refrigerant detectors for ammonia refrigeration are not required for rooms or areas that are always occupied, and for rooms or areas that have high humidity or other harsh environmental conditions that are incompatible with detection devices.~~
4. Surfaces having temperatures exceeding 800°F (427°C) and open flames are not present where any Group A2, B2, A3 or B3 refrigerant is used (see Section 1104.3.4).
5. All electrical *equipment* and appliances conform to Class 1, Division 2, *hazardous location* classification requirements of NFPA 70 where the quantity of any Group A2, B2, A3 or B3 refrigerant, ~~other than ammonia,~~ in a single independent circuit would exceed 25 percent of the lower flammability limit (LFL) upon release to the space.
6. All refrigerant-containing parts in systems with a total connected compressor power exceeding 100 horsepower (hp) (74.6 kW) except evaporators used for refrigeration or dehumidification, condensers used for heating, control and pressure relief valves for either, low-probability pumps and connecting piping are located either outdoors or in a *machinery room*.

1104.3.3 All occupancies. The total of all Group A2, B2, A3 and B3 refrigerants ~~other than R-717, ammonia,~~ shall not exceed 1,100 pounds (499 kg) except where *approved*.

1104.3.4 Protection from refrigerant decomposition. Where any device having an open flame or surface temperature greater than 800°F (427°C) is used in a room containing more than 6.6 pounds (3 kg) of refrigerant in a single independent circuit, a hood and exhaust system shall be provided in accordance with Section 510. Such exhaust system shall exhaust *combustion* products to the outdoors.

Exception: A hood and exhaust system shall not be required where any of the following apply:

1. The refrigerant is R-~~717, R-~~ 718 or R-744.
2. The *combustion* air is ducted from the outdoors in a manner that prevents leaked refrigerant

from being combusted.

1105.6.3 Ventilation rate. ~~For other than ammonia systems, the mechanical~~ Mechanical ventilation systems shall be capable of exhausting the minimum quantity of air both at normal operating and emergency conditions, as required by Sections 1105.6.3.1 and 1105.6.3.2. ~~The minimum required emergency ventilation rate for ammonia shall be 30 air changes per hour in accordance with IIAR 2.~~ Multiple fans or multispeed fans shall be allowed to produce the emergency ventilation rate and to obtain a reduced airflow for normal ventilation.

Delete without substitution:

~~**1105.8 Ammonia discharge.** Pressure relief valves for ammonia systems shall discharge in accordance with ASHRAE 15.~~

Revise as follows:

[F] 1105.9 Emergency pressure control system. ~~Permanently installed refrigeration systems containing more than 6.6 pounds (3 kg) of flammable, toxic or highly toxic refrigerant or ammonia~~ Emergency pressure control systems shall be provided with an emergency pressure control system in accordance with Section 605.10 of the International Fire Code.

Delete without substitution:

~~**1106.3 Ammonia room ventilation.** Ventilation systems in ammonia machinery rooms shall be operated continuously at the ventilation rate specified in Section 1105.6.3.~~

Exceptions:

- ~~1. Machinery rooms equipped with a vapor detector that will automatically start the ventilation system at the ventilation rate specified in Section 1105.6.3, and that will actuate an alarm at a detection level not to exceed 1,000 ppm.~~
- ~~2. Machinery rooms conforming to the Class 1, Division 2, hazardous location classification requirements of NFPA 70.~~

Revise as follows:

1106.4 Flammable refrigerants. Where refrigerants of Groups A2, A3, B2 and B3 are used, the *machinery room* shall conform to the Class 1, Division 2, *hazardous location* classification requirements of NFPA 70.

Exceptions-Exception:

- ~~1. Ammonia machinery rooms that are provided with ventilation in accordance with Section 1106.3.~~
- ~~2. Machinery rooms for systems containing Group A2L refrigerants that are in accordance with Section 1106.5.~~

1108.2 Test gases. Tests shall be performed with an inert dried gas including, but not limited to, nitrogen and carbon dioxide. Oxygen, air, combustible gases and mixtures containing such gases shall not be used.

~~**Exception:** The use of air is allowed to test R-717, ammonia, systems provided that they are subsequently evacuated before charging with refrigerant.~~

Reason:

IIAR is an ANSI accredited standards developer with a complete suite of standards to regulate ammonia refrigeration from initial design through decommissioning of systems. IIAR standards adopted by the IMC and IFC comprehensively regulate ammonia refrigeration, and there is no need to continue the complexity of overlapping requirements in the IMC.

When IIAR 2 was completely rewritten in 2014 to become both a code and a standard, a gap analysis was performed with the IMC and other model codes to confirm or facilitate alignment. The resulting IIAR 2 became a comprehensive document, intended to function as a standalone design regulation without reliance on a mechanical code. This is particularly valuable to jurisdictions in the U.S. and abroad that do not adopt a mechanical code.

A similar change was approved for the 2018 Uniform Mechanical Code. The 2018 UMC no longer covers ammonia refrigeration, instead deferring to IIAR standards. Likewise, ASHRAE is processing Addendum A to ASHRAE 15,

which deletes ammonia refrigeration requirements from that standard.

Cost Impact

The code change proposal will not increase or decrease the cost of construction .

IIAR standards are already adopted by the IMC, and thereby, compliance with these standards is already required. Deferral of ammonia systems to IIAR 2 will reduce the complexity of overlapping regulations and should not impact cost of construction.

Internal ID: 1190

M94-18

IMC: 1101.6, 1101.6.1 (New), 1101.6.2 (New), 1105.8

Proponent: Jeffrey Shapiro, representing International Institute of Ammonia Refrigeration
(jeff.shapiro@intlcodeconsultants.com)

2018 International Mechanical Code

Revise as follows:

1101.6 General. Refrigeration systems shall comply with the requirements of this code ~~and, except as modified by this code, ASHRAE 15. Ammonia refrigerating systems shall comply with this code and, except as modified by this code, ASHRAE 15, IIAR 2, IIAR 3, IIAR 4 and IIAR 5 .~~

Add new text as follows:

1101.6.1 Refrigerants other than ammonia. Where a refrigerant other than ammonia is used, refrigeration systems and the buildings in which such systems are installed shall be in accordance with ASHRAE 15.

1101.6.2 Ammonia refrigeration. Refrigeration systems using ammonia refrigerant and the buildings in which such systems are installed shall comply with IIAR 2, IIAR 3, IIAR 4 and IIAR 5.

Revise as follows:

1105.8 Ammonia discharge. Pressure relief valves for ammonia systems shall discharge in accordance with ~~ASHRAE 15~~ IIAR 2.

Reason:

IIAR 2 has become a standalone standard that no longer relies on ASHRAE 15 for supplemental requirements. Accordingly, it is no longer necessary for the IMC to require ammonia refrigeration systems to comply with both ASHRAE 15 and IIAR 2. This proposal provides direction to users with respect to proper application of the reference standards. In a separate proposal, IIAR is recommending that IMC Chapter 11 completely defer to IIAR 2 and other IIAR standards for regulation of ammonia, and that is the preferred action. However, should that action not be successful, this proposal will at least provide correct references to applicable standards.

Cost Impact

The code change proposal will not increase or decrease the cost of construction .

ASHRAE 15 and IIAR standards are existing reference standards that are already applicable to refrigeration systems. The proposal simply clarifies which standards apply based on the refrigerant being used.

Internal ID: 582

M95-18

IMC: 1101.2, Table 1101.2 (New), 15

Proponent: Jonathan Roberts, UL LLC, representing UL LLC (jonathan.roberts@ul.com)

2018 International Mechanical Code

Revise as follows:

1101.2 Factory-built equipment and appliances. *Listed and labeled* self-contained, factory-built *equipment* and appliances shall be tested in accordance with ~~UL 207, 412, 471 or 1995.~~ the applicable standards specified in Table 1101.2. Such *equipment* and appliances are deemed to meet the design, manufacture and factory test requirements of this code if installed in accordance with their listing and the manufacturer's instructions.

Add new text as follows:

**Table 1101.2
Factory-built equipment and appliances**

<u>EQUIPMENT</u>	<u>STANDARD</u>
<u>Refrigeration fittings, including press-connect, flared, and threaded</u>	<u>UL 109 and UL 207</u>
<u>Air conditioning equipment</u>	<u>UL 1995 or UL/CSA 60335-2-40</u>
<u>Packaged terminal air conditioners</u>	<u>UL 484 or UL/CSA 60335-2-40</u>
<u>Split-system air conditioners</u>	<u>UL 1995 or UL/CSA 60335-2-40</u>
<u>Dehumidifiers</u>	<u>UL 474 or UL/CSA 60335-2-40</u>
<u>Unit coolers</u>	<u>UL 412 or UL/CSA 60335-2-89</u>
<u>Commercial refrigerators, freezers, beverage coolers, and walk-in coolers</u>	<u>UL 471 or UL/CSA 60335-2-89</u>
<u>Refrigerating units and walk-in coolers</u>	<u>UL 427 or UL 60335-2-89</u>
<u>Refrigerant-containing components and accessories</u>	<u>UL 207</u>

Add new standard(s) follows:

UL

UL LLC
333 Pfingsten Road
Northbrook IL 60062-2096

109-97:

Tube Fittings for Flammable and Combustible Fluids, Refrigeration Service and Marine Use

427-11:

Standard for Refrigerating Units

474-15:

Standard for Dehumidifiers

484-14:

Standard for Room Air Conditioners

60335-2-89-17:

Household and Similar Electrical Appliances - Safety - Part 2-89: Particular Requirements for Commercial Refrigerating Appliances with an Incorporated or Remote Refrigerant Unit or Compressor

UL/CSA 60335-2-40 -17:

Household and Similar Electrical Appliances - Safety - Part 2-40: Particular Requirements for Electrical Heat Pumps, Air-Conditioners and Dehumidifiers.

Reason:

Establishing a table to identify the standards that apply to the various types of equipment and appliances will assist in uniform application of this code requirement. Adding UL 109, UL 427, UL 474, UL 484, UL 60335-2-89, and UL 60335-2-40, which are standards used in testing and listing refrigeration equipment, will make the code complete.

Cost Impact

The code change proposal will decrease the cost of construction .

Reduce costs by providing clarity

Analysis: A review of the standard proposed for inclusion in the code, with regard to the ICC criteria for referenced standards (Section 3.6 of CP#28) will be posted on the ICC website on or before April 2, 2018.

Internal ID: 427

M96-18

IMC: 1104.2, 1104.2.1, 1104.3.1, 1104.3.2

Proponent: Julius Ballanco, JB Engineering and Code Consulting, P.C., representing Daikin US (JBEngineer@aol.com)

2018 International Mechanical Code

Revise as follows:

1104.2 Machinery room. Except as provided in Sections 1104.2.1 and 1104.2.2, all components containing the refrigerant shall be located either outdoors or in a *machinery room* where the quantity of refrigerant in an independent circuit of a system exceeds the amounts shown in Table 1103.1. For refrigerant blends not listed in Table 1103.1, the same requirement shall apply where the amount for any blend component exceeds that indicated in Table 1103.1 for that component. This requirement shall also apply where the combined amount of the blend components exceeds a limit of 69,100 parts per million (ppm) by volume. Machinery rooms required by this section shall be constructed and maintained in accordance with Section 1105 for Group A1 and B1 refrigerants and in accordance with Sections 1105 and 1106 for Group ~~A2L, A2, B2L~~, B2, A3 and B3 refrigerants.

Exceptions:

1. Machinery rooms are not required for *listed equipment* and appliances containing not more than 6.6 pounds (3 kg) of refrigerant, regardless of the refrigerant's safety classification, where installed in accordance with the equipment's or appliance's listing and the *equipment* or *appliance* manufacturer's installation instructions.
2. Piping in conformance with Section 1107 is allowed in other locations to connect components installed in a *machinery room* with those installed outdoors.

1104.2.1 Institutional occupancies. The amounts shown in Table 1103.1 shall be reduced by 50 percent for all areas of institutional occupancies except kitchens, laboratories and mortuaries. The total of all Group A2, ~~B2L~~, B2, A3 and B3 refrigerants shall not exceed 550 pounds (250 kg) in occupied areas or machinery rooms.

1104.3.1 Air-conditioning for human comfort. In other than industrial occupancies where the quantity in a single independent circuit does not exceed the amount in Table 1103.1, Group B1, ~~B2L~~, B2 and B3 refrigerants shall not be used in high-probability systems for air-conditioning for human comfort.

1104.3.2 Nonindustrial occupancies. Group A2 and ~~B2L~~, B2 refrigerants shall not be used in high-probability systems where the quantity of refrigerant in any independent refrigerant circuit exceeds the amount shown in Table 1104.3.2. Group A3 and B3 refrigerants shall not be used except where *approved*.

Exception: This section does not apply to laboratories where the floor area per occupant is not less than 100 square feet (9.3 m²).

Reason:

ASHRAE 34 changed the classification of refrigerants. Two new groups were added, A2L and B2L. Previously, these types of refrigerants were subclasses of A2 and B2 respectively. With the change in designation, these sections need to be updated to reflect the additional classifications of refrigerants.

Both A2L and B2L refrigerants are flammable, however, they have a lower burning velocity. A2L refrigerants are used in high probability systems, whereas, B2L refrigerants are not.

Cost Impact

The code change proposal will not increase or decrease the cost of construction .

This change reflect the change in classification of refrigerants.

Internal ID: 1078

M97-18

IMC: TABLE 1103.1

Proponent: Julius Ballanco, representing Daikin US (JBENGINEER@aol.com)

2018 International Mechanical Code

Revise as follows:

TABLE 1103.1

REFRIGERANT CLASSIFICATION, AMOUNT AND OEL

CHEMICAL REFRIGERANT	FORMULA	CHEMICAL NAME OF BLEND	REFRIGERANT CLASSIFICATION	AMOUNT OF REFRIGERANT PER OCCUPIED SPACE				[F] DEGREES OF HAZARD ^a
				Pounds per 1,000 cubic feet	ppm	g/m ³	OEL ^e	
R-11 ^d	CCl ₃ F	trichlorofluoromethane	A1	0.39	1,100	6.2	1,000	2-0-0 ^b
R-12 ^d	CCl ₂ F ₂	dichlorodifluoromethane	A1	5.6	18,000	90	1,000	2-0-0 ^b
R-13 ^d	CCF ₃	chlorotrifluoromethane	A1	—	—	—	1,000	2-0-0 ^b
R-13B1 ^d	CBrF ₃	bromotrifluoromethane	A1	—	—	—	1,000	2-0-0 ^b
R-14	CF ₄	tetrafluoromethane (carbon tetrafluoride)	A1	25	110,000	400	1,000	2-0-0 ^b
R-22	CHClF ₂	chlorodifluoromethane	A1	13	59,000	210	1,000	2-0-0 ^b
R-23	CHF ₃	trifluoromethane (fluoroform)	A1	7.3	41,000	120	1,000	2-0-0 ^b
R-30	CH ₂ Cl ₂	dichloromethane (methylene chloride)	B1	—	—	—	—	—
R-32	CH ₂ F ₂	difluoromethane (methylene fluoride)	A2 ^d Δ2L	4.8	36,000	77	1,000	1-4-0
R-40	CH ₃ Cl	chloromethane (methyl chloride)	B2	—	—	—	—	—
R-50	CH ₄	methane	A3	—	—	—	1,000	—
R-113 ^d	CCl ₃ CClF ₂	1,1,2-trichloro-1,2,2-trifluoroethane	A1	1.2	2,600	20	1,000	2-0-0 ^b
R-114 ^d	CClF ₂ CClF ₂	1,2-dichloro-1,1,2,2-tetrafluoroethane	A1	6.7	20,000	140	1,000	2-0-0 ^b
R-115	CClF ₂ CF ₃	chloropentafluoroethane	A1	47	120,000	760	1,000	—
R-116	CF ₃ CF ₃	hexafluoroethane	A1	34	97,000	550	1,000	1-0-0
R-123	CHCl ₂ CF ₃	2,2-dichloro-1,1,1-trifluoroethane	B1	3.5	9,100	57	50	2-0-0 ^b
R-124	CHClCF ₂ CF ₃	2-chloro-1,1,1,2-tetrafluoroethane	A1	3.5	10,000	56	1,000	2-0-0 ^b
R-125	CHF ₂ CF ₃	pentafluoroethane	A1	23	75,000	370	1,000	2-0-0 ^b
R-134a	CH ₂ FCF ₃	1,1,1,2-tetrafluoroethane	A1	13	50,000	210	1,000	2-0-0 ^b
R-141b	CH ₃ CCl ₂ F	1,1-dichloro-1-fluoroethane	—	0.78	2,600	12	500	2-1-0
R-142b	CH ₃ CClF ₂	1-chloro-1, 1-difluoroethane	A2	5.1	20,000	83	1,000	2-4-0
R-143a	CH ₃ CF ₃	1,1,1-trifluoroethane	A2 ^d Δ2L	4.5	21,000	70	1,000	2-0-0 ^b
R-152a	CH ₃ CHF ₂	1,1-difluoroethane	A2	2.0	12,000	32	1,000	1-4-0
R-170	CH ₃ CH ₃	ethane	A3	0.54	7,000	8.7	1,000	2-4-0
R-E170	CH ₃ OCH ₃	Methoxymethane (dimethyl ether)	A3	1.0	8,500	16	1,000	—
R-218	CF ₃ CF ₂ CF ₃	octafluoropropane	A1	43	90,000	690	1,000	2-0-0 ^b
R-227ea	CF ₃ CHFCF ₃	1,1,1,2,3,3,3-heptafluoropropane	A1	36	84,000	580	1,000	—
R-236fa	CF ₃ CH ₂ CF ₃	1,1,1,3,3,3-hexafluoropropane	A1	21	55,000	340	1,000	2-0-0 ^b
R-245fa	CHF ₂ CH ₂ CF ₃	1,1,1,3,3-pentafluoropropane	B1	12	34,000	190	300	2-0-0 ^b
R-290	CH ₃ CH ₂ CH ₃	propane	A3	0.56	5,300	9.5	1,000	2-4-0
R-C318	-(CF ₂) ₄ -	octafluorocyclobutane	A1	41	80,000	660	1,000	—
R-400 ^d	zeotrope	R-12/114 (50.0/50.0)	A1	10	28,000	160	1,000	2-0-0 ^b
R-400 ^d	zeotrope	R-12/114 (60.0/40.0)	A1	11	30,000	170	1,000	—
R-401A	zeotrope	R-22/152a/124 (53.0/13.0/34.0)	A1	6.6	27,000	110	1,000	2-0-0 ^b
R-401B	zeotrope	R-22/152a/124 (61.0/11.0/28.0)	A1	7.2	30,000	120	1,000	2-0-0 ^b
R-401C	zeotrope	R-22/152a/124 (33.0/15.0/52.0)	A1	5.2	20,000	84	1,000	2-0-0 ^b
R-402A	zeotrope	R-125/290/22 (60.0/2.0/38.0)	A1	17	66,000	270	1,000	2-0-0 ^b
R-402B	zeotrope	R-125/290/22 (38.0/2.0/60.0)	A1	15	63,000	240	1,000	2-0-0 ^b
R-403A	zeotrope	R-290/22/218 (5.0/75.0/20.0)	A2	7.6	33,000	120	1,000	2-0-0 ^b
R-403B	zeotrope	R-290/22/218 (5.0/56.0/39.0)	A1	18	70,000	290	1,000	2-0-0 ^b
R-404A	zeotrope	R-125/143a/134a (44.0/52.0/4.0)	A1	31	130,000	500	1,000	2-0-0 ^b

R-405A	zeotrope	R-22/152a/142b/C318 (45.0/7.0/5.5/2.5)	—	16	57,000	260	1,000	—
R-406A	zeotrope	R-22/600a/142b (55.0/4.0/41.0)	A2	4.7	21,000	25	1,000	—
R-407A	zeotrope	R-32/125/134a (20.0/40.0/40.0)	A1	19	83,000	300	1,000	2-0-0 ^B
R-407B	zeotrope	R-32/125/134a (10.0/70.0/20.0)	A1	21	79,000	330	1,000	2-0-0 ^B
R-407C	zeotrope	R-32/125/134a (23.0/25.0/52.0)	A1	18	81,000	290	1,000	2-0-0 ^B
R-407D	zeotrope	R-32/125/134a (15.0/15.0/70.0)	A1	16	68,000	250	1,000	2-0-0 ^B
R-407E	zeotrope	R-32/125/134a (25.0/15.0/60.0)	A1	17	80,000	280	1,000	2-0-0 ^B
R-407F	zeotrope	R-32/125/134a (30.0/30.0/40.0)	A1	20	95,000	320	1,000	—
R-408A	zeotrope	R-125/143a/22 (7.0/46.0/47.0)	A1	21	95,000	340	1,000	2-0-0 ^B
R-409A	zeotrope	R-22/124/142b (60.0/25.0/15.0)	A1	7.1	29,000	110	1,000	2-0-0 ^B
R-409B	zeotrope	R-22/124/142b (65.0/25.0/10.0)	A1	7.3	30,000	120	1,000	2-0-0 ^B
R-410A	zeotrope	R-32/125 (50.0/50.0)	A1	26	140,000	420	1,000	2-0-0 ^B
R-410B	zeotrope	R-32/125 (45.0/55.0)	A1	27	140,000	430	1,000	2-0-0 ^B
R-411A	zeotrope	R-127/22/152a (1.5/87.5/11.0)	A2	2.9	14,000	46	990	—
R-411B	zeotrope	R-127/22/152a (3.0/94.0/3.0)	A2	2.8	13,000	45	980	—
R-412A	zeotrope	R-22/218/142b (70.0/5.0/25.0)	A2	5.1	22,000	82	1,000	—
R-413A	zeotrope	R-218/134a/600a (9.0/88.0/3.0)	A2	5.8	22,000	94	1,000	—
R-414A	zeotrope	R-22/124/600a/142b (51.0/28.5/4.0/16.5)	A1	6.4	26,000	100	1,000	—
R-414B	zeotrope	R-22/124/600a/142b (50.0/39.0/1.5/9.5)	A1	6.0	23,000	95	1,000	—
R-415A	zeotrope	R-22/152a (82.0/18.0)	A2	2.9	14,000	47	1,000	—
R-415B	zeotrope	R-22/152a (25.0/75.0)	A2	2.1	12,000	34	1,000	—
R-416A	zeotrope	R-134a/124/600 (59.0/39.5/1.5)	A1	3.9	14,000	62	1,000	2-0-0 ^B
R-417A	zeotrope	R-125/134a/600 (46.6/50.0/3.4)	A1	3.5	13,000	56	1,000	2-0-0 ^B
R-417B	zeotrope	R-125/134a/600 (79.0/18.3/2.7)	A1	4.3	15,000	70	1,000	—
R-417C	zeotrope	R-125/134a/600 (19.5/78.8/1.7)	A1	5.4	21,000	87	1,000	—
R-418A	zeotrope	R-290/22/152a (1.5/96.0/2.5)	A2	4.8	22,000	77	1,000	—
R-419A	zeotrope	R-125/134a/E170 (77.0/19.0/4.0)	A2	4.2	15,000	67	1,000	—
R-419B	zeotrope	R-125/134a/E170 (48.5/48.0/3.5)	A2	4.6	17,000	74	1,000	—
R-420A	zeotrope	R-134a/142b (88.0/12.0)	A1	12	45,000	190	1,000	2-0-0 ^B
R-421A	zeotrope	R-125/134a (58.0/42.0)	A1	17	61,000	280	1,000	2-0-0 ^B
R-421B	zeotrope	R-125/134a (85.0/15.0)	A1	21	69,000	330	1,000	2-0-0 ^B
R-422A	zeotrope	R-125/134a/600a (85.1/11.5/3.4)	A1	18	63,000	290	1,000	2-0-0 ^B
R-422B	zeotrope	R-125/134a/600a (55.0/42.0/3.0)	A1	16	56,000	250	1,000	2-0-0 ^B
R-422C	zeotrope	R-125/134a/600a (82.0/15.0/3.0)	A1	18	62,000	290	1,000	2-0-0 ^B
R-422D	zeotrope	R-125/134a/600a (65.1/31.5/3.4)	A1	16	58,000	260	1,000	2-0-0 ^B
R-422E	zeotrope	R-125/134a/600a (58.0/39.3/2.7)	A1	16	57,000	260	1,000	—
R-423A	zeotrope	R-134a/227ea (52.5/47.5)	A1	19	59,000	310	1,000	2-0-0 ^C
R-424A	zeotrope	R-125/134a/600a/600/601a (50.5/47.0/0.9/1.0/0.6)	A1	6.2	23,000	100	970	2-0-0 ^B
R-425A	zoetrope	R-32/134a/227ea (18.5/69.5/12.0)	A1	16	72,000	260	1,000	2-0-0 ^B
R-426A	zeotrope	R-125/134a/600a/601a (5.1/93.0/1.3/0.6)	A1	5.2	20,000	83	990	—
R-427A	zeotrope	R-32/125/143a/134a (15.0/25.0/10.0/50.0)	A1	18	79,000	290	1,000	2-1-0

R-428A	zeotrope	R-125/143a/290/600a (77.5/20.0/0.6/1.9)	A1	23	83,000	370	1,000	—
R-429A	zeotrope	R-E170/152a/600a (60.0/10.0/30.0)	A3	0.81	6,300	13	1,000	—
R-430A	zeotrope	R-152a/600a (76.0/24.0)	A3	1.3	8,000	21	1,000	—
R-431A	zeotrope	R-290/152a (71.0/29.0)	A3	0.69	5,500	11	1,000	—
R-432A	zeotrope	R-1270/E170 (80.0/20.0)	A3	0.13	1,200	2.1	700	—
R-433A	zeotrope	R-1270/290 (30.0/70.0)	A3	0.34	3,100	5.5	880	—
R-433B	zeotrope	R-1270/290 (5.0-95.0)	A3	0.51	4,500	8.1	950	—
R-433C	zeotrope	R-1270/290 (25.0-75.0)	A3	0.41	3,600	6.6	790	—
R-434A	zeotrope	R-125/143a/600a (63.2/18.0/16.0/2.8)	A1	20	73,000	320	1,000	—
R-435A	zeotrope	R-E170/152a (80.0/20.0)	A3	1.1	8,500	17	1,000	—
R-436A	zeotrope	R-290/600a (56.0/44.0)	A3	0.50	4,000	8.1	1,000	—
R-436B	zeotrope	R-290/600a (52.0/48.0)	A3	0.51	4,000	8.1	1,000	—
R-437A	zeotrope	R-125/134a/600/601 (19.5/78.5/1.4/0.6)	A1	5.0	19,000	82	990	—
R-438A	zeotrope	R-32/125/134a/600/601a (8.5/45.0/44.2/1.7/0.6)	A1	4.9	20,000	79	990	—
R-439A	zeotrope	R-32/125/600a (50.0/47.0/3.0)	A2	4.7	26,000	76	990	—
R-440A	zeotrope	R-290/134a/152a (0.6/1.6/97.8)	A2	1.9	12,000	31	1,000	—
R-441A	zeotrope	R-170/290/600a/600 (3.1/54.8/6.0/36.1)	A3	0.39	3,200	6.3	1,000	—
R-442A	zeotrope	R-32/125/134a/152a/227ea (31.0/31.0/30.0/3.0/5.0)	A1	21	100,000	330	1,000	—
R-443A	zeotrope	R-1270/290/600a (55.0/40.0/5.0)	A3	0.19	1,700	3.1	580	—
R-444A	zeotrope	R-32/152a/1234ze(E) (12.0/5.0/83.0)	A2 ^b Δ2L	5.1	21,000	81	850	—
R-444B	zeotrope	R-32/152a/1234ze(E) (41.5/10.0/48.5)	A2 ^b Δ2L	4.3	23,000	69	890	—
R-445A	zeotrope	R-744/134a/1234ze(E) (6.0/9.0/85.0)	A2 ^b Δ2L	4.2	16,000	67	930	—
R-446A	zeotrope	R-32/1234ze(E)/600 (68.0/29.0/3.0)	A2 ^b Δ2L	2.5	16,000	39	960	—
R-447A	zeotrope	R-32/125/1234ze(E) (68.0/3.5/28.5)	A2 ^b Δ2L	2.6	16,000	42	900	—
R-448A	zeotrope	R-32/125/1234yf/134a/1234ze(E) (26.0/26.0/20.0/21.0/7.0)	A1	24	110,000	390	890	—
R-449A	zeotrope	R-32/125/1234yf/134a (24.3/24.7/25.3/25.7)	A1	23	100,000	370	830	—
R-450A	zeotrope	R-134a/1234ze(E) (42.0/58.0)	A1	20	72,000	320	880	—
R-451A	zeotrope	R-1234yf/134a (89.8/10.2)	A2 ^b Δ2L	5.3	18,000	81	520	—
R-451B	zeotrope	R-1234yf/134a (88.8/11.2)	A2 ^b Δ2L	5.3	18,000	81	530	—
R-452A	zeotrope	R-32/125/1234yf (11.0/59.0/30.0)	A1	27	100,000	440	780	—
R-500 ^c	azeotrope	R-12/152a (73.8/26.2)	A1	7.6	30,000	120	1,000	2-0-0 ^b
R-501 ^d	azeotrope	R-22/12 (75.0/25.0)	A1	13	54,000	210	1,000	—
R-502 ^c	azeotrope	R-22/115 (48.8/51.2)	A1	21	73,000	330	1,000	2-0-0 ^b
R-503 ^c	azeotrope	R-23/13 (40.1/59.9)	—	—	—	—	1,000	2-0-0 ^b
R-504 ^d	azeotrope	R-32/115 (48.2/51.8)	—	28	140,000	450	1,000	—
R-507A	azeotrope	R-125/143a (50.0/50.0)	A1	32	130,000	520	1,000	2-0-0 ^b
R-508A	azeotrope	R-23/116 (39.0/61.0)	A1	14	55,000	220	1,000	2-0-0 ^b
R-508B	azeotrope	R-23/116 (46.0/54.0)	A1	13	52,000	200	1,000	2-0-0 ^b
R-509A	azeotrope	R-22/218 (44.0/56.0)	A1	24	75,000	390	1,000	2-0-0 ^b
R-510A	azeotrope	R-E170/600a (88.0/12.0)	A3	0.87	7,300	14	1,000	—
R-511A	azeotrope	R-290/E170 (95.0/5.0)	A3	0.59	5,300	9.5	1,000	—
R-512A	azeotrope	R-134a/152a (5.0/95.0)	A2	1.9	11,000	31	1,000	—
R-513A	azeotrope	R-1234yf/134a (56.0/44.0)	A1	20	72,000	320	650	—
R-600	CH ₃ CH ₂ CH ₂ CH ₃	butane	A3	0.15	1,000	2.4	1,000	1-4-0
R-600a	CH(CH ₃) ₂ CH ₃	2-methylpropane (isobutane)	A3	0.59	4,000	9.6	1,000	2-4-0
R-601	CH ₃ CH ₂ CH ₂ CH ₂ CH ₃	pentane	A3	0.18	1,000	2.9	600	—

R-601a	$(\text{CH}_3)_2\text{CHCH}_2\text{CH}_3$	2-methylbutane (isopentane)	A3	0.18	1,000	2.9	600	—
R-610	ethoxyethane (ethyl ether)	$\text{CH}_3\text{CH}_2\text{OCH}_2\text{CH}_3$	—	—	—	—	400	—
R-611	methyl formate	HCOOCH_3	B2	—	—	—	100	—
R-717	NH_3	ammonia	B2 ^b B2L	0.014	320	0.22	25	3-3-0 ^c
R-718	H_2O	water	A1	—	—	—	—	0-0-0
R-744	CO_2	carbon dioxide	A1	4.5	40,000	72	5,000	2-0-0 ^b
R-1150	$\text{CH}_2=\text{CH}_2$	ethene (ethylene)	A3	—	—	—	200	1-4-2
R-1233zd(E)	$\text{CF}_3\text{CH}=\text{CHCl}$	trans-1-chloro-3,3,3-trifluoro-1-propene	A1	5.3	16,000	85	800	—
R-1234yf	$\text{CF}_3\text{CF}=\text{CH}_2$	2,3,3,3-tetrafluoro-1 propene	A2 ^b A2L	4.7	16,000	75	500	—
R-1234ze(E)	$\text{CF}_3\text{CH}=\text{CHF}$	trans-1,3,3,3-tetrafluoro-1-propene	A2 ^b A2L	4.7	16,000	75	800	—
R-1270	$\text{CH}_3\text{CH}=\text{CH}_2$	Propene (propylene)	A3	0.1	1,000	1.7	500	1-4-1

For SI: 1 pound = 0.454 kg, 1 cubic foot = 0.0283m³

- a. Degrees of hazard are for health, fire, and reactivity, respectively, in accordance with NFPA 704.
- b. Reduction to 1-0-0 is allowed if analysis satisfactory to the code official shows that the maximum concentration for a rupture or full loss of refrigerant charge would not exceed the IDLH, considering both the refrigerant quantity and room volume.
- c. For installations that are entirely outdoors, use 3-1-0.
- d. Class I ozone depleting substance; prohibited for new installations.
- e. Occupational Exposure Limit based on the OSHA PEL, ACGIH TLV-TWA, the TERA WEEL or consistent value on a time-weighted average (TWA) basis (unless noted C for ceiling) for an 8 hr/d and 40 hr/wk.
- f. ~~The ASHRAE Standard 34 flammability classification for this refrigerant is 2L, which is a subclass of Class 2.~~

Reason:

ASHRAE 34 changed the classification of refrigerants. Two new groups were added, A2L and B2L. Previously, these types of refrigerants were subclasses of A2 and B2 respectively. With the change in designation, the table needs to be updated to reflect the appropriate classification. Additionally, note f no longer applies.

Cost Impact

The code change proposal will not increase or decrease the cost of construction .

This only changes the classification of existing refrigerants.

Internal ID: 1075

M98-18

IMC: 1103.1

Proponent: Julius Ballanco, representing Daikin US (JBENGINEER@aol.com)

2018 International Mechanical Code

Revise as follows:

1103.1 Refrigerant classification. Refrigerants shall be classified in accordance with ASHRAE 34 as listed in Table 1103.1. Each refrigerant shall be assigned to a single group of refrigerants. The group of refrigerants shall be A1, A2L, A2, A3, B1, B2L, B2, and B3.

Reason:

This proposed change adds general requirements found in ASHRAE 34. This added text will assist the code official in understanding how refrigerants are classified into a specific group of refrigerants. It will also make it clear to the code official that a refrigerant can only fall within one group of refrigerants.

ASHRAE 34 approved a change making A2L and B2L full groups of refrigerants. Previously, A2L was a subgroup of A2 and B2L was a subgroup of B2 refrigerants.

Cost Impact

The code change proposal will not increase or decrease the cost of construction .

This change only impacts the classification of refrigerants.

Internal ID: 1074

M99-18

IMC: 1107, 1107.1 (New), 1107.2 (New), 1107.3 (New), 1107.4 (New), TABLE 1107.4 (New), 1107.4.1 (New), 1107.5 (New), TABLE 1107.5 (New), 1107.5.1 (New), TABLE 1107.5.1 (New), 1107.6 (New), 1107.7 (New), SECTION 1108 (New), 1108.1 (New), 1108.1.1 (New), 1108.2 (New), 1108.3 (New), 1108.3.1 (New), 1108.3.2 (New), 1108.3.2.1 (New), 1108.3.2.2 (New), 1108.3.3 (New), 1108.3.4 (New), 1108.3.5 (New), 1108.4 (New), 1108.5 (New), 1108.6 (New), 1108.7 (New), 1108.8 (New), 1108.9 (New), SECTION 1109 (New), 1109.1 (New), 1109.2 (New), 1109.2.1 (New), 1109.2.2 (New), 1109.2.3 (New), 1109.2.4 (New), 1109.2.5 (New), 1109.2.6 (New), 1109.3 (New), 1109.3.1 (New), 1109.3.2 (New), TABLE 1109.3.2 (New), 1109.3.3 (New), 1109.4 (New), 1109.4.1 (New), 1109.4.3 (New), 1109.5 (New), 1109.6 (New), 1109.7 (New), 1109.8 (New), 1109.8.1 (New), 1109.8.2 (New), 1109.8.3 (New), 1109.8.4 (New), 1110, 1110.1 (New), 1110.2 (New), 1110.3 (New), 1110.4 (New), 1110.5 (New), 1110.5.1 (New), 1110.5.2 (New), 1110.6 (New), 1110.7 (New), 1110.8 (New)

Proponent: Julius Ballanco, JB Engineering and Code Consulting, P.C., representing Daikin US (Chair, Refrigerant Piping Committee) (JBENGINEER@aol.com)

2018 International Mechanical Code

Delete and substitute as follows:

~~SECTION 1107 REFRIGERANT PIPING~~ ~~SECTION 1107 PIPING MATERIAL~~

~~**1107.1 Piping.** Refrigerant piping material for other than R-717 (ammonia) systems shall conform to the requirements in this section.~~

~~Piping material and installations for R-717 (ammonia) refrigeration systems shall comply with IAR 2.~~

~~**1107.2 Used Materials.** Used pipe, fittings, valves and other materials that are to be reused shall be clean and free of foreign materials and shall be approved for reuse.~~

~~**1107.3 Material rating.** Materials, joints and connections shall be rated for the operating temperature and pressure of the refrigerant system. Materials shall be suitable for the type of refrigerant and type of lubricant in the refrigerant system. Magnesium alloys shall not be used in contact with any halogenated refrigerants. Aluminum, zinc, magnesium, and their alloys shall not be used in contact with R-40 (methyl chloride).~~

~~**1107.4 Piping materials standards.** Refrigerant pipe shall conform to one or more of the standards listed in Table 1107.4. The exterior of the pipe shall be protected from corrosion and degradation.~~

TABLE 1107.4
REFRIGERANT PIPE

<u>Piping Material</u>	<u>Standard (See Chapter 15)</u>
<u>Aluminum Tube</u>	<u>ASTM B210.</u> <u>ASTM B210M.</u> <u>ASTM B491/B491M</u>
<u>Brass (Copper Alloy) Pipe</u>	<u>ASTM B43</u>
<u>Copper Pipe</u>	<u>ASTM B42.</u> <u>ASTM B302</u>
<u>Copper Tube^a</u>	<u>ASTM B68.</u> <u>ASTM B75.</u> <u>ASTM B88.</u> <u>ASTM B280.</u> <u>ASTM B819</u>
<u>Copper Linesets</u>	<u>ASTM B1003.</u> <u>ASTM B280</u>
<u>Steel Pipe^b</u>	<u>ASTM A53.</u> <u>ASTM A106</u>
<u>Steel Tube</u>	<u>ASTM A254.</u> <u>ASTM A334</u>

a. Soft annealed copper tubing larger than 1³/₈ in. (35 mm) O.D. shall not be used for field assembled refrigerant piping, unless it is protected from mechanical damage.

b. ASTM A53, Type F steel pipe shall not be used for refrigerant lines having an operating temperature less than -20°F (-29°C).

1107.4.1 Steel pipe Group A2, A3, B2, and B3. The minimum weight of steel pipe for Group A2, A3, B2, and B3 refrigerants shall be Schedule 80 for sizes 1-1/2 inch or less in diameter.

1107.5 Pipe fittings. Refrigerant pipe fittings shall be approved for installation with the piping materials to be installed, and shall conform to one of more of the standards listed in Table 1107.5 or shall be listed and labeled as complying with UL 207.

**TABLE 1107.5
REFRIGERANT PIPE FITTINGS**

<u>Fitting Material</u>	<u>Standard (See Chapter 15)</u>
<u>Aluminum</u>	<u>ASTM B361</u>
<u>Brass (Copper Alloy)</u>	<u>ASME B16.15.</u> <u>ASME B16.24</u>
<u>Copper</u>	<u>ASME B16.15.</u> <u>ASME B16.18.</u> <u>ASME B16.22.</u> <u>ASME B16.24.</u> <u>ASME B16.26.</u> <u>ASME B16.50</u>
<u>Steel</u>	<u>ASTM A105.</u> <u>ASTM A181.</u> <u>ASTM A193.</u> <u>ASTM A234.</u> <u>ASTM A420.</u> <u>ASTM A707</u>

1107.5.1 Copper brazed field swaged. The minimum and maximum cup depth of field fabricated copper brazed swaged fitting connections shall comply with Table 1107.5.1.

**TABLE 1107.5.1
COPPER BRAZED SWAGED CUP DEPTHS**

<u>Fitting Size (Inch)</u>	<u>Minimum Depth (Inch)</u>	<u>Maximum Depth (Inch)</u>
<u>1/8</u>	<u>0.15</u>	<u>0.23</u>
<u>3/16</u>	<u>0.16</u>	<u>0.24</u>
<u>1/4</u>	<u>0.17</u>	<u>0.26</u>
<u>3/8</u>	<u>0.20</u>	<u>0.30</u>
<u>1/2</u>	<u>0.22</u>	<u>0.33</u>
<u>5/8</u>	<u>0.24</u>	<u>0.36</u>
<u>3/4</u>	<u>0.25</u>	<u>0.38</u>
<u>1</u>	<u>0.28</u>	<u>0.42</u>
<u>1-1/4</u>	<u>0.31</u>	<u>0.47</u>
<u>1-1/2</u>	<u>0.34</u>	<u>0.51</u>
<u>2</u>	<u>0.40</u>	<u>0.60</u>
<u>2-1/2</u>	<u>0.47</u>	<u>0.71</u>
<u>3</u>	<u>0.53</u>	<u>0.80</u>
<u>3-1/2</u>	<u>0.59</u>	<u>0.89</u>
<u>4</u>	<u>0.64</u>	<u>0.96</u>

1107.6 Valves. Valves shall be of materials that are compatible with the type of piping material, refrigerants, and oils in the system. Valves shall be listed and labeled and rated for the temperatures and pressures of the refrigerant systems in which the valves are installed.

1107.7 Flexible connectors, expansion and vibration compensators. Flexible connectors and expansion and vibration control devices shall be listed and labeled for use in refrigerant systems.

SECTION 1108 JOINTS AND CONNECTIONS

1108.1 Approval. Joints and connections shall be of an approved type. Joints and connections shall be tight for the pressure of the refrigerant system when tested in accordance with Section 1110.

1108.1.1 Joints between different piping materials.. Joints between different piping materials shall be made with approved adapter fittings. Joints between dissimilar metallic piping materials shall be made with a dielectric fitting or a dielectric union conforming to dielectric tests of ASSE 1079. Adapter fittings with threaded ends between different materials shall be joined with thread lubricant in accordance with Section 1108.3.4.

1108.2 Preparation of pipe ends. Pipe shall be cut square, reamed and chamfered, and shall be free of burrs and obstructions. Pipe ends shall have full-bore openings and shall not be undercut.

1108.3 Joint preparation and installation. Where required by Sections 1108.4 through 1108.9, the preparation and installation of brazed, flared, mechanical, press-connect, soldered, threaded and welded joints shall comply with Sections 1108.3.1 through 1108.3.5.

1108.3.1 Brazed joints. Joint surfaces shall be cleaned. An approved flux shall be applied where required by the braze filler metal manufacturer. The piping being brazed shall be purged of air to remove the oxygen and filled with one of the following inert gases: oxygen-free nitrogen, helium, or argon. The piping system shall be pre-purged with an inert gas for a minimum time corresponding to five volume changes through the piping system prior to brazing. The pre-purge rate shall be at a minimum velocity of 100 feet per minute. The inert gas shall be directly connected to the tube system being brazed to prevent the entrainment of ambient air. After the pre-purge, the inert gas supply shall be maintained through the piping during the brazing operation at a minimum pressure of 1.0 psi and a maximum pressure of 3.0 psi. The joint shall be brazed with a filler metal conforming to AWS A5.8.

1108.3.2 Mechanical joints. Mechanical joints shall be installed in accordance with the manufacturer's instructions.

1108.3.2.1 Flared joints. Flared fittings shall be installed in accordance with the manufacturer's instructions. The flared fitting shall be used with the tube material specified by the fitting manufacturer. The flared tube end shall be made by a tool designed for that operation.

1108.3.2.2 Press-connect joints. Press-connect joints shall be installed in accordance with the manufacturer's instructions.

1108.3.3 Soldered joints.. Joint surfaces to be soldered shall be cleaned and a flux conforming to ASTM B 813 shall be applied. The joint shall be soldered with a solder conforming to ASTM B 32. Solder joints shall be limited to refrigerant systems using Group A1 refrigerant and having a pressure of less than or equal to 200 psi.

1108.3.4 Threaded joints.. Threads shall conform to ASME B1.20.1, ASME B1.20.3, ASME B1.13M, or ASME B1.1. Thread lubricant, pipe-joint compound, or thread tape shall be applied on the external threads only and shall be approved for application on the piping material.

1108.3.5 Welded joints. Joint surfaces to be welded shall be cleaned by an approved procedure. Joints shall be welded with an approved filler metal.

1108.4 Aluminum tube. Joints between aluminum tubing or fittings shall be brazed, mechanical, press-connect, or welded joints conforming to Section 1108.3.

1108.5 Brass (copper alloy) pipe. Joints between brass pipe or fittings shall be brazed, mechanical, press-connect, threaded, or welded joints conforming to Section 1108.3.

1108.6 Copper pipe. Joints between copper or copper-alloy pipe or fittings shall be brazed, mechanical, press-connect, soldered, threaded, or welded joints conforming to Section 1108.3.

1108.7 Copper tube. Joints between copper or copper-alloy tubing or fittings shall be brazed, flared, mechanical, press-connect, or soldered joints.

1108.8 Steel pipe. Joints between steel pipe or fittings shall be mechanical joints, threaded, press-connect, or welded joints conforming to Section 1108.3.

1108.9 Steel tube. Joints between steel tubing or fittings shall be flared, mechanical, press-connect, or welded joints conforming to Section 1108.3.

SECTION 1109 REFRIGERANT PIPE INSTALLATION

1109.1 General. Refrigerant piping installations, other than R-717 (ammonia) refrigeration systems, shall comply with the requirements of this section. The design of refrigerant piping shall be in accordance with ASME B31.5.

1109.2 Piping location. Refrigerant piping shall comply with the installation location requirements of Sections 1109.2.1 through 1109.2.6. Refrigerant piping for group A2L and B2L shall also comply with the requirements of Section 1109.3. Refrigerant piping for group A2, A3, B2 and B3 shall also comply with the requirements of Section 1109.4.

1109.2.1 Minimum height.. Exposed refrigerant piping installed in open spaces that afford passage shall be not less than 7 feet 3 inches (2210 mm) above the finished floor.

1109.2.2 Refrigerant pipe enclosure. Refrigerant piping shall be protected by locating it within the building elements or within protective enclosures.

Exception: Piping protection within the building elements or protective enclosure shall not be required in any of the following locations:

1. Where installed without ready access or located more than 7 feet 3 inches (2210 mm) above the finished floor.
2. Where located within 6 feet (1830 mm) of the refrigerant unit or appliance.
3. Where located in a machinery room complying with Section 1105.

1109.2.3 Prohibited locations. Refrigerant piping shall not be installed in any of the following locations:

1. Exposed within a fire-resistance-rated exit access corridor,
2. Interior exit stairway,
3. Interior exit ramp,
4. Exit passageway, or

5. Elevator, dumbwaiter or other shaft containing a moving object.

1109.2.4 Piping in concrete floors. Refrigerant piping installed in concrete floors shall be encased in pipe, conduit, or ducts. The piping shall be protected to prevent damage from vibration, stress and corrosion.

1109.2.5 Refrigerant pipe shafts. Refrigerant piping that penetrates two or more floor/ceiling assemblies shall be enclosed in a fire-resistance-rated shaft enclosure. The fire-resistance-rated shaft enclosure shall comply with Section 713 of the International Building Code.

Exceptions:

1. For systems using R718 refrigerant.
2. Piping in a direct system using Group A1 refrigerant where the refrigerant quantity does not exceed the limits of Table 1103.1 for the smallest occupied space through which the piping passes.
2. Piping located on the exterior of the building where vented to the outdoors.

1109.2.6 Exposed piping surface temperature. Exposed piping with ready access having surface temperatures greater than 120°F (49°C) or less than 5°F (-15°C) shall be protected from contact or shall have thermal insulation that limits the exposed insulation surface temperature to a range of 5°F (-15°C) to 120°F (49°C).

1109.3 Installation requirements for A2L and B2L refrigerants. Piping systems using Group A2L or B2L refrigerant shall comply with the requirements of Sections 1109.3.1 through 1109.3.3.

1109.3.1 Pipe protection. In addition to the requirements of Section 305.5, aluminum, copper, and steel tube used for Group A2L and B2L refrigerants and located in concealed locations where tubing is installed in studs, joists, rafters or similar member spaces and located less than 1-1/2 inches (38 mm) from the nearest edge of the member, shall be continuously protected by shield plates. Protective steel shield plates having a minimum thickness of 0.0575 inch (1.463 mm) (No. 16 gage) shall cover the area of the tube plus the area extending not less than 2 inches beyond both sides of the tube..

1109.3.2 Shaft ventilation. Refrigerant pipe shafts with systems using Group A2L or B2L refrigerants shall be naturally or mechanically ventilated. The shaft ventilation exhaust outlet shall comply with Section 501.3.1. Naturally ventilated shafts shall have a pipe, duct, or conduit not less than 4 inches in diameter that connects to the lowest point of the shaft and extends to the outdoors. The pipe, duct, or conduit shall be level or pitched downward to the outdoors. Mechanically ventilated shafts shall have a minimum airflow velocity in accordance with Table 1109.3.2. The mechanical ventilation shall be continuously operated or activated by a refrigerant detector. Systems utilizing a refrigerant detector shall activate the mechanical ventilation at a maximum refrigerant concentration of 25 percent of the lower flammable limit of the refrigerant. The detector, or a sampling tube that draws air to the detector, shall be located in an area where refrigerant from a leak will concentrate. The shaft shall not be required to be ventilated for double wall refrigerant pipe where the interstitial space of the double wall pipe is vented to the outdoors.

**TABLE 1109.3.2
SHAFT VENTILATION VELOCITY**

Cross Sectional Area of Shaft (sq. in.)	Minimum Ventilation Velocity (feet per minute)
≤ 20	100
> 20 - ≤ 250	200
> 250 - ≤ 1250	300
> 1250	400

1109.3.3 Pipe identification. Refrigerant pipe located in areas other than the room or space where the refrigerating equipment is located shall be identified. The pipe identification shall be located at intervals not exceeding 20 feet on the refrigerant piping or pipe insulation. The identification shall indicate the refrigerant designation and safety group classification of refrigerant used in the piping system. For Group B2L refrigerants the identification shall also include the following statement: "DANGER - Toxic Refrigerant." The minimum height of lettering of the identification label shall be ½ inch.

1109.4 Installation requirements for A2, A3, B2, and B3 refrigerants. Piping systems using Group A2, A3, B2, or B3 refrigerant shall comply with the requirements of Section 1109.4.1 through 1109.4.3.

1109.4.1 Piping material. Piping material for Group A2, A3, B2, or B3 refrigerant located inside the building, except for machinery rooms, shall be copper pipe, brass pipe, or steel pipe. Pipe joints located in areas other than the machinery room shall be welded. Self-contained listed and labeled equipment or appliances shall have piping material based on the listing requirements.

1109.4.3 Shaft ventilation. Refrigerant pipe shafts with systems using Group A2, A3, B2, or B3 refrigerants shall be continuously mechanically ventilated. The shaft ventilation exhaust outlet shall comply with Section 501.3.1. Mechanically ventilated shafts shall have a minimum airflow velocity as specified in Table 1109.3.2. The shaft shall not be required to be ventilated for double wall refrigerant pipe where the interstitial space of the double wall pipe is vented to the outdoors.

1109.4.3 Pipe identification.. Refrigerant pipe shall be identified with the refrigerant designation and safety group classification of refrigerant used in the piping system and the following statement: "DANGER - Risk of Fire or Explosion, Flammable Refrigerant." For Group B2 and B3 refrigerants the identification shall also include the following statement: "DANGER - Toxic Refrigerant." The identification shall be at intervals not exceeding 5 feet on the refrigerant piping or pipe insulation. The minimum height of lettering of the identification label shall be 1 inch.

1109.5 Refrigerant pipe penetrations. The annular space between the outside of a refrigerant pipe and the inside of a pipe sleeve or opening in a building envelope wall, floor, or ceiling assembly penetrated by a refrigerant pipe shall be sealed in an approved manner with caulking material, foam sealant or closed with a gasketing system. The caulking material, foam sealant or gasketing system shall be designed for the conditions at the penetration location and shall be compatible with the pipe, sleeve and building materials in contact with the sealing materials. Refrigerant pipes penetrating fire-resistance-rated assemblies or membranes of fire-resistance-rated assemblies shall be sealed or closed in accordance with Section 714 of the International Building Code.

1109.6 Stress and strain. Refrigerant piping shall be installed so as to prevent strains and stresses that exceed the structural strength of the pipe. Where necessary, provisions shall be made to protect piping from damage resulting from vibration, expansion, contraction, and structural settlement.

1109.7 Condensate control. Refrigerating piping and fittings that, during normal operation, will reach a surface temperature below the dew point of the surrounding air, and are located in spaces or areas where condensation has the potential to cause a safety hazard to the building occupants, structure, electrical equipment or any other equipment or appliances, shall be insulated or protected in an approved manner to prevent damage from condensation.

1109.8 Stop valves. Stop valves shall be installed in specified locations in accordance with Sections 1109.8.1 and 1109.8.2. Stop valves shall be supported in accordance with Section 1109.8.3 and identified in accordance with Section 1109.8.4.

Exceptions:

1. Systems that have a refrigerant pump out function capable of storing the entire refrigerant

- charge in a receiver or heat exchanger.
2. Systems that are equipped with provisions for pump out of the refrigerant using either portable or permanently installed refrigerant recovery equipment.
 3. Self-contained listed and labeled systems.

1109.8.1 Refrigerating systems containing more than 6.6 pounds (3.0 kg) of refrigerant. Stop valves shall be installed in the following locations on refrigerating systems containing more than 6.6 pounds (3.0 kg) of refrigerant:

1. The suction inlet of each compressor, compressor unit or condensing unit.
2. The discharge outlet of each compressor, compressor unit or condensing unit.
3. The outlet of each liquid receiver.

1109.8.2 Refrigerating systems containing more than 100 pounds (45 kg) of refrigerant. In addition to stop valves required by Section 1109.8.1, systems containing more than 100 pound (45 kg) of refrigerant shall have stop valves installed in the following locations:

1. Each inlet of each liquid receiver.
2. Each inlet and each outlet of each condenser, where more than one condenser is used in parallel

Exceptions:

1. Stop valves shall not be required on the inlet of a receiver in a condensing unit, nor on the inlet of a receiver that is an integral part of the condenser.
2. Systems utilizing nonpositive displacement compressors.

1109.8.3 Stop valve support. Stop valves shall be supported to prevent detrimental stress and strain on the refrigerant piping system. The piping system shall not be utilized to support stop valves on copper tubing or aluminum tubing 1 inch (25.4 mm) OD or larger in diameter.

1109.8.4 Identification. Stop valves shall be identified where their intended purpose is not obvious. Where valves are identified by a numbering or lettering system, legend(s) or key(s) for the valve identification shall be located in the room containing the indoor refrigeration equipment. The minimum height of lettering of the identification label shall be ½ inch (12.7 mm).

SECTION 1108 FIELD TEST

SECTION 1110 REFRIGERANT PIPING SYSTEM TEST

1110.1 General. Refrigerant piping systems, other than R-717 (ammonia) refrigeration systems, that are erected in the field, shall be pressure tested for strength and leak tested for tightness, in accordance with the requirements of this section, after installation and before being placed in operation, Tests shall include both the high and low-pressure sides of each system.

Exception: Listed and labeled equipment, including compressors, condensers, vessels, evaporators, gas bulk storage tanks, safety devices, pressure gauges and control mechanisms, shall not be required to be tested.

1110.2 Exposure of refrigerant piping system. Refrigerant pipe and joints installed in the field shall be exposed for visual inspection and testing prior to being covered or enclosed.

1110.3 Test gases. The medium used for pressure testing the refrigerant system shall be one of the following inert gases: oxygen-free nitrogen, helium, or argon. For R-744 refrigerant systems carbon dioxide shall be allowed as the test medium. For R-718 refrigerant systems water shall be allowed as the test medium. Oxygen, air, combustible gases and mixtures containing such gases shall not be used as test medium. Systems erected on the premises with tubing not exceeding 5/8 inch (15.8 mm) OD shall be allowed to use the refrigerant identified on the nameplate label or marking as the test medium.

1110.4 Test apparatus. The means used to pressurize the refrigerant piping system shall have on its outlet side, a test pressure measuring device and either a pressure-limiting device or a pressure-reducing device. The test pressure measuring device shall have an accuracy of ±3 percent or less of the test pressure, and shall have a resolution of 5% or less of the test pressure.

1110.5 Piping system pressure test and leak test. The refrigerant piping system shall be tested as a whole or separate tests shall be conducted for the low pressure-side and high pressure-side of the piping system. The refrigerant piping system shall be tested in accordance with both of the following methods:

1. The system shall be pressurized for a period of not less than 60 minutes to not less than the lower of the design pressures or the setting of the pressure relief device(s). The design pressures for testing shall be the pressure listed on the label nameplate of the condensing unit, compressor, compressor unit, pressure vessel, or other system component with a nameplate. Additional test gas shall not be added to the system after the start of the pressure test. The system shall not show loss of pressure on the test pressure measuring device during the pressure test. Where using refrigerant as a test medium in accordance with Section 1110.3, the test pressure shall be not less than the saturation dew point pressure at 77°F (25°C).
2. A vacuum of 500 microns shall be achieved. After achieving a vacuum, the system shall be isolated from the vacuum pump. The system pressure shall not rise above 1500 microns for a period of not less than 10 minutes.

1110.5.1 Joints and refrigerant-containing parts in air ducts. Joints and all refrigerant-containing parts of a refrigerating system located in an air duct of an air-conditioning system that conveys conditioned air to and from human-occupied spaces shall be tested at a pressure of 150 percent of the higher of the design pressure or pressure relief device setting.

1110.5.2 Limited charge systems. Limited-charge systems with a pressure relief device, erected on the premises, shall be tested at a pressure not less than one and one-half times the pressure setting of the relief device. Listed and labeled limited charge systems shall be tested at the equipment or appliance design pressure.

1110.6 Booster compressor. Where a compressor protected by a pressure relief device is used as a booster to obtain an intermediate pressure and such compressor discharges into the suction side of another compressor, the booster compressor shall be considered to be a part of the low pressure side of the system.

1110.7 Centrifugal/nonpositive displacement compressors. Where testing systems using centrifugal or other nonpositive displacement compressors, the entire system shall be considered to be the low pressure-side for test purposes.

1110.8 Contractor or engineer declaration. The installing contractor or registered design professional of record shall issue a certificate of test to the code official for all systems containing 55 pounds (25 kg) or more of refrigerant. The certificate shall give the test date, name of the refrigerant, test medium, and the field test pressure applied to the high pressure-side and the low pressure-side of the system. The certification of test shall be signed by the installing contractor or registered design professional and shall be made part of the public record.

Reason:

I organized a group of 8 experts in the field of refrigerant piping to help develop this code change. I refer to them as the Refrigerant Piping Committee. However, I am submitting this change as the proponent. In addition to the Committee I created, I circulated a draft to other experts in the field of refrigeration. I received a number of comments through that review. Those comments have been incorporated in the final text that I am submitting.

It is the intent of the Refrigerant Piping Committee to submit a similar change to ASHRAE 15 and the UMC. The goal is to update all refrigerant piping requirements addressing every type of refrigerant system other than ammonia.

This proposed change reorganizes and updates the requirements for refrigerant piping. Many of the requirements remain the same as in the current code. The change follows the format used in other chapters in the Mechanical Code and Plumbing Code for listing piping material, joints and connections, and installation requirement.

Section 1107 remains the piping material section, however, the title is changed to be consistent with other chapters. There is no need to repeat refrigerant. Section 1107.1 is the general section indicating that compliance to the section for material requirements. The exception to Section 1107.1 is necessary to clarify that the ammonia piping requirements are regulated by IIAR 2. Without this statement, there could be confusion since Section 1101.6 states to apply IIAR 2 except as modified by this code. The piping requirements do not apply to ammonia systems. Similar exception language appears in Section 1109.1 and 1110.1.

There is currently no section regarding used materials, yet other chapters include requirements for used materials. This section is similar to the used material requirements in other chapters.

Section 1107.3 is a general requirement for the piping material to be rated for the temperatures, pressures, and type of refrigerant. The aluminum exception for R-40 (methyl chloride) currently appears in Section 1107.5.5. The

requirements have been expanded to include zinc and magnesium alloys since these materials are also susceptible to failure from R-40 (methyl chloride). Magnesium alloys cannot be used with any halogenated refrigerants since the material will react and fail. This prohibition has been added.

Section 1107.4 includes a table for listing all of the acceptable piping material. The appropriate standards for the piping material are listed in the table. While the word brass was previously converted to copper alloy throughout the code, ASTM B43 is still identified as a brass pipe standard. Therefore, brass was used with copper alloy included in parenthesis.

The current code has a restriction on the use of mechanical joints with annealed copper tubing. This is a hold over requirement that is out of date. ASME B31.5 has a different limitation. Note 1 to the table includes the requirements listed in ASME B31.5.

Note 2 of the table currently appears in Section 1107.5.1. The requirement remains the same.

Section 1107.5 includes a table of the fitting standards used in refrigerant piping systems. Some of the standards are new to this chapter since the previous requirements were weak with regard to referencing the appropriate fitting standards. There is also a general reference to UL 207. There are refrigerant fittings that do not meet the fitting standard, however, they are listed to UL 207. This is an appropriate standard for specialty type of refrigerant fittings.

Copper tubing is a common material used in refrigerant piping systems. A common joint is a swaged fitting which is made in the field. Since the swaging of copper expands the wall of the pipe, thus weakening the outer tube of the joint where not supported by the joint filler material and inner tube, the depth of the swage must be included. This depth is similar to the brazed fitting cup depths in the ASME B16.50 standard. The maximum depth allows a 50% increase in cup depth. A greater depth will result in too weak a pipe wall.

Section 1107.6 adds requirements for valves. The current code has valve installation requirements but is missing valve material requirements.

Section 1107.7 adds material requirements for flexible connectors and expansion and vibration compensators. These components are required to be listed and labeled for refrigerant systems.

Section 1108 is organized similar to the joints and connections section in Chapter 12. Many of the requirements are new since the current code requirements are not up to date. The section is organized with general requirements in the beginning, followed by joining methods, and completed with piping material allowances of various joining methods.

Section 1108.1 is the general section on joints requiring them to be approved and meet the tightness requirements to pass the system test.

Section 1108.1.1 lists requirements for joints between different materials. A reference to the testing requirements in ASSE 1079 is made in the section for joints between dissimilar metals. The standard has appropriate testing requirements for dielectric tests that can be used on refrigeration piping systems even though the standard appears to address water piping systems. Section 1108.2 is similar to the preparation of pipe ends found in other chapters. The same requirements would apply to refrigerant piping.

Section 1108.3 lists all of the acceptable joining methods. For brazing, there are requirements for using an inert gas inside the piping. This prevents oxidation on the interior of the piping. If there is excessive oxidation, it could result in obstruction of small piping or components in the system, as well as other system chemistry degradation, increasing the probability of future repair work. Reducing the frequency of opening refrigerating systems for repair reduces the exposure to numerous hazards and risks. For many of the joints, a reference to UL 207 is included. This standard covers the various refrigerant joining methods. The press-connect refrigerant fittings are listed to this standard, as are many mechanical joints.

Section 1108.3.4 includes all of the various threads that are used in refrigerant piping systems. This expands the listing of ASME standards for threaded joints.

Sections 1108.4 through 1108.9 list each material and the acceptable joining methods for the particular material.

The piping installation requirements are listed in a separate section from the material and joints and connections. The piping requirements have been expanded to address the necessary safety measures to assure a proper piping installation.

With a greater use of VRV and VRF systems, there is significantly more refrigerant piping installed inside a building. Additionally, with split systems and multi-split systems in multistory residential buildings, there is also a significant amount of piping installed.

There will be an expanded use of Group A2L refrigerants that are low global warming potential refrigerants. These refrigerants were previously listed as a subgroup of A2 refrigerants. As a separate group, the requirements need to be provided to address the installation of piping with Group A2L refrigerants.

The new section on piping is divided into four main subject matters. The first part of the section addresses piping

requirements for all types of refrigerants being used. The second part is for Group A2L and B2L refrigerants. The third part is for piping requirements for Group A2, A3, B2, and B3 refrigerants. The last part has additional general requirements for piping installations.

Section 1109.1 includes a reference to ASME B31.5. This standard is currently referenced in Section 1107.1. There is no change regarding the application of ASME B31.5.

Section 1109.2 identifies which sections are applicable to which refrigerant groups.

Section 1109.2.1 is a rewording of the requirements currently found in Section 1107.2.

Section 1109.2.2 is a new section requiring refrigerant piping to be concealed within the building elements. While this is implied in the current code, it is not stated. Section 1109.2.2.1, allowing refrigerant piping to be exposed, is similar to the current allowance specified in Sections 1107.2 and 1107.3. The other allowance would be refrigerant piping located in a machinery room. Exposed piping is anticipated in a machinery room where access is restricted to authorized personnel.

Section 1109.2.3 is similar to current Section 1107.2. One of the changes is the allowance for refrigerant piping to be located in the ceiling of a corridor, hence, not exposed. This appears to be implied, however, when the ceiling space is considered a part of the corridor, it appears to be prohibited. Refrigerant piping, especially for multi-split systems is often installed in the ceiling of a corridor. If the RCL requirements are met, there is no hazard posed to the corridor.

Section 1109.2.4 is a duplication of the requirements currently found in Section 1107.2.1.

Section 1109.2.5 is a new section regulating the requirements for shaft containing refrigerant piping. A fire-resistance-rated shaft will be required when the refrigerant piping connects three or more stories. Other utilities can also be located within the same shaft. There are three exceptions proposed to the shaft requirements in Section 1109.2.5.1, one is when water is use, that is R718 refrigerant. The second is for the use of Group A1 refrigerants provided the smallest space in which the pipe pass meets the RCL requirements for the refrigerant. The last exception is for when the piping is installed on the outside of the building where any leak would vent to atmosphere.

Section 1109.2.6 is also a new requirement. This section is intended to protect an individual from directly contacting a hot or cold refrigerant pipe. The temperatures are based on avoiding burning the skin or causing frostbite or frost damage to the skin. One of the methods of protection would adding insulation around the pipe. This is the most common method of protection for exposed piping.

Section 1109.3 is a new section regulating the installation of piping using Group A2L or B2L refrigerants. These refrigerants are lower flammable, lower burning velocity refrigerants. While the refrigerant will burn, it doesn't ignite or burn very easily. Since it is flammable additional protection requirements are proposed.

Section 1109.3.1 will require continuous protection when the piping is located within 1-1/2 inches of the nearest edge of a member. Currently the code requires this level of protection in certain locations, such as the top plate and bottom plate. This section will require the protection where ever the piping is installed. The protection is intended to prevent the tubing from be punctured by a nail or screw.

Section 1109.3.2 requires ventilation of the shaft in which the refrigerant piping is located. A minimal movement of air will exhaust the leaking refrigerant out of the shaft. The velocity rates identified in Table 1109.3.2 are taken from a peer reviewed paper published by ASME, and ensure that density differences between air and refrigerant will not defeat the purpose to exhaust the released refrigerant out of the shaft, whether in horizontal or vertical shaft orientation.

The ventilation would only be required when there is a leak of refrigerant. A leak detector is required in the shaft to identify when a leak occurs. Another option would be to naturally ventilate the shaft or continuously ventilate the shaft. Since most refrigerants are heavier than air, they tend to move downward. If naturally ventilated, the refrigerant moves to outside the building. An exception to the ventilation requirements would be the use of double wall pipe. While this is not commonly installed, the possibility exists that there will be greater use of double wall pipe.

The final requirement in Section 1109.3.3 specifies the labeling requirements for the piping. Since B2L refrigerant is toxic, there are special requirements to label the pipe as containing toxic refrigerant.

Section 1109.4 has the special requirement for the more flammable and more toxic refrigerants. Section 1109.4.1 requires the systems to be installed using only pipe, not tubing. The added strength of the pipe will reduce any potential leak from a puncture. The exception to this requirement would be self-contained listed equipment. Some refrigerators and similar appliances are using Group A3 refrigerants. However, these appliances are tested and listed.

Section 1109.4.2 requires any shaft with these refrigerants to be continuously ventilated. The same velocity requirements apply to this group of refrigerants as Group A2L and B2L. There is also an exception for double wall pipe.

Section 1109.4.3 specifies the labeling requirements. The labels are similar to what is required in UL/CSA 60335-2-40.

Section 1109.5 is a new section regulating pipe penetrations. Any time a pipe penetrated a wall, floor, or ceiling, it must be sealed to prevent the passage of any refrigerant that may be leaking. There is a direct reference to the building

code for penetrations of fire-resistance-rated assemblies.

Section 1109.6 is a new requirement for pipe protection. Similar language has been used for other piping systems in the Mechanical Code and the Plumbing Code. The requirements are also applicable to refrigerant piping.

Sections 1109.7 through 1109.8.4 are rewording and relocation of current Sections 1107.4, 1107.8, 1107.8.1, 1107.8.2, and 1107.8.3.

The Refrigerant Piping Committee spent a considerable amount of time rewriting and discussing the testing requirements. The basis for Section 1110 is the current Section 1108. The key elements of Section 1108 are captured in the new section. The significant differences relate to the test medium, the test equipment, and the pressure and vacuum test.

The test gas is specified as being either oxygen-free nitrogen, helium, or argon. These are the three inert gases used for testing refrigerant piping systems. Carbon dioxide refrigerant systems are permitted to be tested with carbon dioxide. Water refrigerant piping systems are permitted to be tested with water.

For smaller systems, refrigerant contractors have used the refrigerant for testing. This would be permitted for systems having 5/8 inch or smaller tubing.

The accuracy of the test gage is not currently specified. Most test gages used by refrigerant contractors have an accuracy within 2-1/2 percent. The allowance for up to 3 percent takes into consideration other gages that may be used.

For the testing of the system, the Committee believes it is important to run two tests; one is a pressure test, the other is a vacuum test. When testing with internal pressures, a one-way leak in the reverse direction may not be discovered. However, when a vacuum is placed on the system, the leak will be identified. The standard test for refrigerant systems is one hour for pressure and 10 minutes for a vacuum. These tests have been added to the section.

Cost Impact

The code change proposal will increase the cost of construction .

The additional testing required for refrigerant piping will take additional time which equates to a high cost for labor.

Internal ID: 886

M100-18

IMC: 1107.5.3.1 (New)

Proponent: Pennie Feehan, representing Plumbing, Mechanical, and Fuel Gas Code Action Committee (PMGCAC@iccsafe.org)

2018 International Mechanical Code

Add new text as follows:

1107.5.3.1 Copper joints. Joints in copper tubing shall not be made with epoxy or adhesives

Reason:

Refrigerant tubing should be joined by proven methods that have longevity, strength and resistance to heat and corrosion. Refrigerants can be toxic, flammable or both and can be harmful to the environment. There are no test or product standards for epoxy joints for refrigerant tubing.

This proposal is submitted by the ICC Plumbing/Mechanical/Gas Code Action Committee (PMG CAC). The PMG CAC was established by the ICC Board of Directors to pursue opportunities to improve and enhance the International Codes or portions thereof that were under the purview of the PMG CAC. In 2017 the PMG CAC held one face-to-face meeting and 11 conference call meetings. Numerous interested parties attended the committee meetings and offered their input.

Cost Impact

The code change proposal will not increase or decrease the cost of construction .

This proposal will not increase the cost of construction because no additional labor, materials, equipment, appliances or devices are mandated beyond what is currently required by the code.

Internal ID: 480

M101-18

IMC: 1103.2, TABLE 1104.3.2

Proponent: Phillip Johnson, representing self (phillip.johnson@daikinapplied.com)

2018 International Mechanical Code

1103.2 Occupancy classification. Locations of refrigerating systems are described by *occupancy* classifications that consider the ability of people to respond to potential exposure to refrigerants. Where *equipment* or appliances, other than piping, are located outside a building and within 20 feet (6096 mm) of any building opening, such *equipment* or appliances shall be governed by the *occupancy* classification of the building. *Occupancy* classifications shall be defined as follows:

1. Institutional *occupancy* is that portion of premises from which occupants cannot readily leave without the assistance of others because they are disabled, debilitated or confined. Institutional occupancies include, among others, hospitals, nursing homes, asylums and spaces containing locked cells.
2. Public assembly *occupancy* is that portion of premises where large numbers of people congregate and from which occupants cannot quickly vacate the space. Public assembly occupancies include, among others, auditoriums, ballrooms, classrooms, passenger depots, restaurants and theaters.
3. Residential *occupancy* is that portion of premises that provides the occupants with complete independent living facilities, including permanent provisions for living, sleeping, eating, cooking and sanitation. Residential occupancies include, among others, dormitories, hotels, multiunit apartments and private residences.
4. Commercial *occupancy* is that portion of premises where people transact business, receive personal service or purchase food and other goods. Commercial occupancies include, among others, office and professional buildings, markets (but not large mercantile occupancies) and work or storage areas that do not qualify as industrial occupancies.
5. Large mercantile *occupancy* is that portion of premises where more than 100 persons congregate on levels above or below street level to purchase personal merchandise.
6. Industrial *occupancy* is that portion of premises that is not open to the public, where access by authorized persons is controlled, and that is used to manufacture, process or store goods such as chemicals, food, ice, meat or petroleum.
7. Mixed *occupancy* occurs where two or more occupancies are located within the same building. Where each *occupancy* is isolated from the rest of the building by tight walls, floors and ceilings and by self-closing doors, the requirements for each *occupancy* shall apply to its portion of the building. Where the various occupancies are not so isolated, the *occupancy* having the most stringent requirements shall be the governing *occupancy*.

Revise as follows:

**TABLE 1104.3.2
MAXIMUM PERMISSIBLE QUANTITIES OF REFRIGERANTS**

TYPE OF REFRIGERATION SYSTEM	MAXIMUM POUNDS FOR VARIOUS OCCUPANCIES			
	Institutional	Public Assembly	Residential	All other occupancies
Sealed absorption system				
In exit access	0	0	3.3	3.3
In adjacent outdoor locations	0	0	22	22
In other than exit access	0	6.6	6.6	6.6
Unit systems				
In other than exit access	0	0	6.6	6.6

For SI: 1 pound = 0.454 kg.

Reason:

The occupancy type "Assembly" in Table 1104.3.2 is incomplete and should be "Public Assembly" to be consistent with occupancy types as defined in Section 1103.2.

Cost Impact

The code change proposal will not increase or decrease the cost of construction .

Editorial change only, no technical change so no cost impact.

Internal ID: 1513

M103-18

IMC: TABLE 1202.4, TABLE 1202.5, 1203.3.4, 1203.8 (New), 1203.9, 1203.9.1, 15

Proponent: Forest Hampton, Lubrizol Advance Materials, Inc., representing Lubrizol Advanced Materials, Inc.
(forest.hampton@lubrizol.com)

2018 International Mechanical Code

Revise as follows:

**TABLE 1202.4
HYDRONIC PIPE**

MATERIAL	STANDARD (see Chapter 15)
Acrylonitrile butadiene styrene (ABS) plastic pipe	ASTM D1527; ASTM F2806
Chlorinated polyvinyl chloride (CPVC) plastic pipe	ASTM D2846; ASTM F441; ASTM F442
<u>Chlorinated Polyvinyl Chloride/Aluminum/Chlorinated Polyvinyl Chloride (CPVC/AL/CPVC)</u>	<u>ASTM F2855</u>
Copper or copper-alloy pipe	ASTM B42; ASTM B43; ASTM B302
Copper or copper-alloy tube (Type K, L or M)	ASTM B75; ASTM B88; ASTM B135; ASTM B251
Cross-linked polyethylene/aluminum/cross-linked polyethylene (PEX-AL-PEX) pressure pipe	ASTM F1281; CSA CAN/CSA-B-137.10
Cross-linked polyethylene (PEX) tubing	ASTM F876
Ductile iron pipe	AWWA C115/A21.15; AWWA C151/A21.51
Lead pipe	FS WW-P-325B
Polyethylene/aluminum/polyethylene (PE-AL-PE) pressure pipe	ASTM F1282; CSA B137.9
Polypropylene (PP) plastic pipe	ASTM F2389
Polyvinyl chloride (PVC) plastic pipe	ASTM D1785; ASTM D2241
Raised temperature polyethylene (PE-RT)	ASTM F2623; ASTM F2769; CSA B137.18
Steel pipe	ASTM A53; ASTM A106
Steel tubing	ASTM A254

**TABLE 1202.5
HYDRONIC PIPE FITTINGS**

MATERIAL	STANDARD (see Chapter 15)
Copper and copper alloys	ASME B16.15; ASME B16.18; ASME B16.22; ASME B16.26; ASME B16.24; ASME B16.51; ASSE 1061; ASTM F1974
Ductile iron and gray iron	ANSI/AWWA C110/A21.10; AWWA C153/A21.53; ASTM A395; ASTM A536; ASTM F1476; ASTM F1548
Ductile iron	ANSI/AWWA C153/A21.53
Gray iron	ASTM A126
Malleable iron	ASME B16.3
PE-RT fittings	ASSE 1061;ASTM D3261;ASTM F1807; ASTM F2098; ASTM F2159; ASTM F2735; ASTM F2769;CSA B137.1; CSA B137.18
PEX fittings	ASSE 1061;ASTM F877; ASTM F1807; ASTM F1960; ASTM F2080; ASTM F2159
Plastic	ASTM D2466; ASTM D2467; <u>ASTM D2846</u> ; ASTM F438; ASTM F439; ASTM F877; ASTM F2389; ASTM F2735
Steel	ASME B16.5; ASME B16.9; ASME B16.11; ASME B16.28; ASTM A53; ASTM A106; ASTM A234; ASTM A395; ASTM A420; ASTM A536; ASTM F1476; ASTM F1548

1203.3.4 Solvent-cemented joints. Joint surfaces shall be clean and free of moisture. An *approved* primer shall be applied to CPVC and PVC pipe-joint surfaces. Joints shall be made while the cement is wet. Solvent cement conforming to the following standards shall be applied to all joint surfaces:

1. ASTM D2235 for ABS joints.
2. ASTM F493 for CPVC joints.
3. ASTM D2564 for PVC joints.

CPVC joints shall be made in accordance with ASTM D2846.

Exception: For CPVC pipe joint connections, a primer is not required where all of the following conditions apply:

1. The solvent cement used is third-party certified as conforming to ASTM F493.
2. The solvent cement is yellow in color.
3. The solvent cement is used only for joining 1/2-inch (12.7 mm) through 2-inch (51 mm) diameter CPVC pipe and fittings.
4. The CPVC pipe ~~and or~~ fittings are manufactured in accordance with ASTM D2846.

Add new text as follows:

1203.8 CPVC/AL/CPVC plastic pipe. Joints between CPVC/AL/CPVC plastic pipes or fittings shall be mechanical, solvent-cemented or threaded joints conforming to Section 1203.3

Revise as follows:

~~1203.8.1~~**1203.9 Polybutylene plastic pipe and tubing.** Joints between polybutylene plastic pipe and tubing or fittings shall be mechanical joints conforming to Section 1203.3 or heat-fusion joints conforming to Section ~~1203.8.1~~**1203.9.1.**

~~1203.8.1~~**1203.9.1 Heat-fusion joints.** Joints shall be of the socket-fusion or butt-fusion type. Joint surfaces shall be clean and free of moisture. Joint surfaces shall be heated to melt temperatures and joined. The joint shall be undisturbed until cool. Joints shall be made in accordance with ASTM D3309.

Add new standard(s) follows:

ASTM

ASTM International
100 Barr Harbor Drive, P.O. Box
C700
West Conshohocken PA 19428

F2855-12:

Standard Specification for Chlorinated Poly(Vinyl Chloride)/Aluminum/Chlorinated Poly(Vinyl Chloride) (CPVC-AL-CPVC) Composite Pressure Tubing

Reason:

Chlorinated Polyvinyl Chloride/Aluminum/Chlorinated Polyvinyl Chloride (CPVC/AL/CPVC) pipe was added to chapter 6 of the 2015 IPC for water service and water distribution pipe. It can also be used for hydronic piping and should be recognized in Chapter 12 of the IMC to give installers another option.

Cost Impact

The code change proposal will not increase or decrease the cost of construction .

The addition of this piping material will not increase the cost of construction as it only adds another option for the installer.

Internal ID: 1646

M104-18

IMC: Chapter 12, TABLE 1202.4, TABLE 1202.5, ordinal

Proponent: Gary Morgan, Viega LLC, representing Viega LLC (gary.morgan@viega.us); LANCE MacNevin, representing Plastics Pipe Institute (Lmacnevin@plasticpipe.org)

2018 International Mechanical Code

CHAPTER 12 HYDRONIC PIPING

Revise as follows:

**TABLE 1202.4
HYDRONIC PIPE**

MATERIAL	STANDARD (see Chapter 15)
Acrylonitrile butadiene styrene (ABS) plastic pipe	ASTM D1527; ASTM F2806
Chlorinated polyvinyl chloride (CPVC) plastic pipe	ASTM D2846; ASTM F441; ASTM F442
Copper or copper-alloy pipe	ASTM B42; ASTM B43; ASTM B302
Copper or copper-alloy tube (Type K, L or M)	ASTM B75; ASTM B88; ASTM B135; ASTM B251
Cross-linked polyethylene/aluminum/cross-linked polyethylene (PEX-AL-PEX) pressure pipe	ASTM F1281; CSA CAN/CSA-B-137.10
Cross-linked polyethylene (PEX) tubing	ASTM F876; <u>ASTM F3253</u>
Ductile iron pipe	AWWA C115/A21.15; AWWA C151/A21.51
Lead pipe	FS WW-P-325B
Polyethylene/aluminum/polyethylene (PE-AL-PE) pressure pipe	ASTM F1282; CSA B137.9
Polypropylene (PP) plastic pipe	ASTM F2389
Polyvinyl chloride (PVC) plastic pipe	ASTM D1785; ASTM D2241
Raised temperature polyethylene (PE-RT)	ASTM F2623; ASTM F2769; CSA B137.18
Steel pipe	ASTM A53; ASTM A106
Steel tubing	ASTM A254

**TABLE 1202.5
HYDRONIC PIPE FITTINGS**

MATERIAL	STANDARD (see Chapter 15)
Copper and copper alloys	ASME B16.15; ASME B16.18; ASME B16.22; ASME B16.26; ASME B16.24; ASME B16.51; ASSE 1061; ASTM F1974
Ductile iron and gray iron	ANSI/AWWA C110/A21.10; AWWA C153/A21.53; ASTM A395; ASTM A536; ASTM F1476; ASTM F1548
Ductile iron	ANSI/AWWA C153/A21.53
Gray iron	ASTM A126
Malleable iron	ASME B16.3
PE-RT fittings	ASSE 1061;ASTM D3261;ASTM F1807; ASTM F2098; ASTM F2159; ASTM F2735; ASTM F2769;CSA B137.1; CSA B137.18
PEX fittings	ASSE 1061;ASTM F877; ASTM F1807; ASTM F1960; ASTM F2080; ASTM F2159; <u>ASTM F3253</u>
Plastic	ASTM D2466; ASTM D2467; ASTM F438; ASTM F439; ASTM F877; ASTM F2389; ASTM F2735
Steel	ASME B16.5; ASME B16.9; ASME B16.11; ASME B16.28; ASTM A53; ASTM A106; ASTM A234; ASTM A395; ASTM A420; ASTM A536; ASTM F1476; ASTM F1548

Add new standard(s) follows:

ASTM

ASTM International
100 Barr Harbor Drive, P.O. Box
C700
West Conshohocken PA 19428
US

F3253-2017:

Standard Specification for Crosslinked Polyethylene (PEX) Tubing with Oxygen Barrier for Hot - and Cold - Water Hydronic Distribution Systems

Reason:

ASTM's committee on plastics piping recently completed a new Standard, F3253 - Standard Specification for Crosslinked Polyethylene (PEX) Tubing with Oxygen Barrier for Hot - and Cold - Water Hydronic Distribution Systems. This new system standard covers both the oxygen barrier PEX tubing as well as the performance and material requirements for the fittings. While this standard essentially mirrors the existing ASTM F876 and F877 PEX standards from a dimensional standpoint and existing fittings interchangeability, it also mandates the inclusion of an oxygen barrier layer with defined pass/fail criteria essentially equal with the industry's long accepted norm of DIN 4726 concerning allowed oxygen permeation. This new standard also requires a minimum pull-out strength test for the fittings not included in ASTM F877 today. The inclusion of this new standard in no way changes the acceptance of the existing ASTM F876 and F877 which will remain in the mechanical hydronics code for the foreseeable future.

This standard's project has been in works for nearly 4 years and represents the work and input from nearly all of the PEX tubing manufacturers in North America. Your support of this proposal is most appreciated.

Cost Impact

The code change proposal will not increase or decrease the cost of construction .

This additional standard will not result in any increased costs for construction.

Internal ID: 865

M105-18

IMC: 1203.9.3

Proponent: Richard Houle, Reliance Worldwide Corporation, representing Reliance Worldwide Corporation (rich.houle@rwc.com)

2018 International Mechanical Code

Delete without substitution:

~~**1203.9.3 Push-fit joints.** Push-fit joints that create a seal on the outside diameter of the tubing shall not be used with tubing that has an ethylene vinyl alcohol copolymer (EVOH) oxygen barrier layer.~~

Reason:

This code language is unnecessary as the standard for PEX tubing (ASTM F876) requires that the PEX tubing be marked with the standard designation(s) for the fitting system(s) approved for use with their tubing. The language is overly restrictive as some PEX manufactures have used the Push-to-Connect fittings on EVOH barrier tubing for years with great success. Reliance Worldwide Corporation support the use of Push-to-Connect Fittings on EVOH tubing and has not had any field issues with it use in this application. We respectfully request that this language be removed to allow those PEX manufacturers that wish to support the use of Push-to-Connect fittings on barrier tubing to continue to allow their use.

Cost Impact

The code change proposal will not increase or decrease the cost of construction .

There is no cost impact because the fittings are already approved in the code. The added restriction is unnecessary because the approval of different fitting systems is already covered in the ASTM F876 Standard which addresses approved fittings with the PEX tubing by the tubing manufacturer.

Internal ID: 1349

M106-18

IMC: TABLE 1202.5

Proponent: William Chapin, Professional Code Consulting, LLC, representing Professional Code Consulting, LLC
(bill@profcc.us)

2018 International Mechanical Code

Revise as follows:

**TABLE 1202.5
HYDRONIC PIPE FITTINGS**

MATERIAL	STANDARD (see Chapter 15)
Copper and copper alloys	ASME B16.15; ASME B16.18; ASME B16.22; ASME B16.26; ASME B16.24; ASME B16.51; ASSE 1061; ASTM F1974
<u>CPVC</u>	<u>ASSE 1061; ASTM D2846</u>
Ductile iron and gray iron	ANSI/AWWA C110/A21.10; AWWA C153/A21.53; ASTM A395; ASTM A536; ASTM F1476; ASTM F1548
Ductile iron	ANSI/AWWA C153/A21.53
Gray iron	ASTM A126
Malleable iron	ASME B16.3
PE-RT fittings	ASSE 1061;ASTM D3261;ASTM F1807; ASTM F2098; ASTM F2159; ASTM F2735; ASTM F2769;CSA B137.1; CSA B137.18
PEX fittings	ASSE 1061;ASTM F877; ASTM F1807; ASTM F1960; ASTM F2080; ASTM F2159
Plastic	ASTM D2466; ASTM D2467; ASTM F438; ASTM F439; ASTM F877; ASTM F2389; ASTM F2735
Steel	ASME B16.5; ASME B16.9; ASME B16.11; ASME B16.28; ASTM A53; ASTM A106; ASTM A234; ASTM A395; ASTM A420; ASTM A536; ASTM F1476; ASTM F1548

Reason:

CPVC is an accepted hydronic pipe in table 1202.4, but the CPVC fittings were not listed in table 1202.5. ASSE 1061 fittings are tested and listed to be used with CPVC that complies with ASTM D2846 and fittings that comply with ASTM D2846 are allowed as stated in section 1203.3.4.

Cost Impact

The code change proposal will not increase or decrease the cost of construction .

Adding existing fittings to table

Internal ID: 1755

M107-18

IMC: 1203.14.3

Proponent: William Chapin, Professional Code Consulting, LLC, representing Professional Code Consulting, LLC (bill@profcc.us)

2018 International Mechanical Code

Revise as follows:

1203.14.3 Push-fit joints. ~~Push-fit joints that create a seal on the outside diameter of the tubing shall not be used with tubing that has an ethylene vinyl alcohol copolymer (EVOH) oxygen barrier layer. fittings shall comply with ASSE 1061 and be used with PE-RT tubing that is rated for use with such fittings by the tubing manufacturer.~~

Reason:

The language in the 2018 edition was not accepted by the 2018 Code Committee because 1) there was no technical evidence presented that there is an issue using certain fittings with EVOH tubing, and 2) stating how a product should not be used is improper code language. Even though the public comment submitted had no technical evidence to support the change, this myth was perpetuated at the Public Comment hearing and won a narrow and poorly attended floor vote. While it should not influence this specific Committee, it should be noted that this language is not in the 2018 IPC, IRC, or any other code in this country where PE-RT tubing applications are listed.

Due to the vast number of joining technologies, the issue of fitting use is addressed in the ASTM standards for PE-RT tubing. These standards require the tubing manufacturer to clearly mark the standard designation of the fitting system(s) for which the tubing is recommended for use. The proposed language will make the installer and code official cognizant of the installation requirements without having to add language of what not to do.

Cost Impact

The code change proposal will not increase or decrease the cost of construction .

This proposal bring the code back to the proper installation language.

Internal ID: 1944

M108-18

IMC: 1203.9.3

Proponent: William Chapin, Professional Code Consulting, LLC, representing Professional Code Consulting, LLC (bill@profcc.us)

2018 International Mechanical Code

Revise as follows:

1203.9.3 Push-fit joints. ~~fittings. Push-fit joints that create a seal on the outside diameter of the tubing shall not fittings shall comply with ASSE 1061 and be used with tubing that has an ethylene vinyl alcohol copolymer (EVOH) oxygen barrier layer. PEX tubing that is rated for use with such fittings by the tubing manufacturer.~~

Reason:

The language in the 2018 edition was not accepted by the 2018 Code Committee because 1) there was no technical evidence presented that there is an issue using certain fittings with EVOH PEX tubing, 2) there is a long history of these fittings in use with all PEX tubing, and 3) stating how a product should not be used is improper code language. Even though the public comment submitted had no technical evidence to support the change, this myth was perpetuated at the Public Comment hearing and won a narrow and poorly attended floor vote. While it should not influence this specific Committee, it should be noted that this language is not in the 2018 IPC, IRC, or any other code in this country where PEX tubing applications are listed.

Due to the vast number of joining technologies and PEX manufacturing methods, the issue of fitting use is addressed in the ASTM F876 standard for PEX tubing. ASTM F876 requires the tubing manufacturer to clearly mark the standard designation of the fitting system(s) for which the tubing is recommended for use. The proposed language will make the installer and code official cognizant of the installation requirements without having to add language of what not to do.

Cost Impact

The code change proposal will not increase or decrease the cost of construction .

This proposal returns this code to previous language.

Internal ID: 1925

M109-18

IMC: TABLE 1210.4, TABLE 1210.5, 1210.8, 15

Proponent: LANCE MacNevin, Plastics Pipe Institute, representing Plastics Pipe Institute (lmacnevin@plasticpipe.org); Mark Metzner, IGSHPA Canada, representing IGSHPA Canada (markmetzner@shaw.ca)

2018 International Mechanical Code

Revise as follows:

**TABLE 1210.4
GROUND-SOURCE LOOP PIPE**

MATERIAL	STANDARD (see Chapter 15)
Chlorinated polyvinyl chloride (CPVC)	ASTM D2846; ASTM F441; ASTM F442
Cross-linked polyethylene (PEX)	ASTM F876; CSA B137.5; <u>CSA C448</u>
Polyethylene/aluminum/polyethylene (PE-AL-PE) pressure pipe	ASTM F1282; CSA B137.9
High-density polyethylene (HDPE)	ASTM D2737; ASTM D3035; ASTM F714; AWWA C901; CSA B137.1; CSA C448; NSF 358-1
Polypropylene (PP-R)	ASTM F2389; CSA B137.11; NSF 358-2
Polyvinyl chloride (PVC)	ASTM D1785; ASTM D2241
Raised temperature polyethylene (PE-RT)	ASTM F2623; ASTM F2769; CSA B137.18; <u>CSA C448</u>

**TABLE 1210.5
GROUND-SOURCE LOOP PIPE FITTINGS**

PIPE MATERIAL	STANDARD (see Chapter 15)
Chlorinated polyvinyl chloride (CPVC)	ASTM D2846; ASTM F437; ASTM F438; ASTM F439; CSA B137.6
Cross-linked polyethylene (PEX)	ASTM F877; ASTM F1807; ASTM F1960; ASTM F2080; ASTM F2159; ASTM F2434; CSA B137.5; CSA 448
Polyethylene/aluminum/polyethylene (PE-AL-PE)	ASTM F1282; ASTM F2434; CSA B137.9
High Density Polyethylene (HDPE)	ASTM D2683; ASTM D3261; ASTM F1055; CSA B137.1; CSA C448; CSA 448; NSF 358-1
Polypropylene (PP-R)	ASTM F2389; CSA B137.11; NSF 358-2
Polyvinyl chloride (PVC)	ASTM D2464; ASTM D2466; ASTM D2467; CSA B137.2; CSA B137.3
Raised temperature polyethylene (PE-RT)	ASTM D3261; ASTM F1807; ASTM F2098; ASTM F2159; ASTM F2735; ASTM F2769; CSA B137.1; CSA B137.18; CSA 448

1210.8 Installation. Piping, valves, fittings, and connections shall be installed in accordance with ANSI/CSA/IGSHPA C448 and the conditions of approval.

Update standard(s) as follows:



CSA Group
8501 East Pleasant Valley Road
Cleveland OH 44131-5516

ANSI/CSA/IGSHPA C448 Series—16:

Design and Installation of Earth Energy Systems

Reason:

This proposal is on behalf of the International Ground Source Heat Pump Association (IGSHPA); Mark Metzner - President of IGSHPA Canada and the Chairman of ANSI/CSA/IGSHPA C448; and The Plastics Pipe Institute.

ANSI/CSA/IGSHPA C448-16 contains specific requirements for HDPE, PEX and PE-RT piping systems (pipe and fittings) for use as ground loop piping systems. By adding reference to C448 in this row, this will indicate that this material is explicitly approved in ANSI/CSA/IGSHPA C448-16. ANSI/CSA/IGSHPA C448-16 “Design and installation of ground source heat pump systems for commercial and residential buildings” is an ANSI designated bi-national consensus standard for the design and installation of ground source heat pump systems. It was first published in February 2016.

ANSI/CSA/IGSHPA C448-16 is the first ANSI approved consensus standard for the design and installation of ground source systems.

ANSI/CSA/IGSHPA C448-16 replaces the original version known as CSA C448-02, already referenced within the IMC Chapter 12. ANSI/CSA/IGSHPA C448-16 is a greatly enhanced system standard which includes the industry knowledge of ground source geothermal systems gained since 2002.

The Standard includes performance-based criteria that provides a consistent application of requirements and best practices throughout the United States and Canada. This Standard will ensure that stakeholders in the ground source heat pump systems market sector will supply and receive ground source heating / cooling systems that perform to design efficiency expectations and deliver true, long-term value.

This Standard was developed by a Bi-national Technical Committee which comprised of the industry's leaders from Canada and USA, including representatives of the following industry associations:

- American Society for Heating, Refrigeration and Air Conditioning Engineers (ASHRAE)
- Geothermal Exchange Organization (GEO)
- International Ground Source Heat Pump Association (IGSHPA)
- International Ground Source Heat Pump Association Canada (IGSHPA - Canada)
- National Ground Water Association (NGWA)
- The Plastics Pipe Institute (PPI)
- Geothermal National & International Initiative (GEONII)

Heating, Refrigeration and Air Conditioning Institute of Canada (HRAI)

ANSI/CSA/IGSHPA C448-16 includes performance-based minimum requirements for industrial, commercial, institutional and residential applications. It addresses the following items related to ground source heat pump systems:

- equipment and material selection (including ground loop piping)
- site survey - geological and hydrogeological
- open and closed loop ground source heat pump system design / engineering
- direct expansion (DX) systems
- installation
- testing and verification
- documentation
- commissioning and decommissioning

ANSI/CSA/IGSHPA C448-16 applies to all ground source heat pump systems using outdoor ground loop heat exchangers as a thermal source or sink for heating and cooling, with or without supplementary heating or cooling source/s. The types of outdoor heat exchangers covered by this Standard include:

- ground heat exchangers - vertical and horizontal
- open-loop systems - drilled well and surface water
- submerged closed loop systems - fresh water and sea water
- standing column wells

The latest version of ANSI/CSA/IGSHPA C448 is available from CSA Program Manager Jovan Cheema; jovan.cheema@csagroup.org

Cost Impact

The code change proposal will not increase or decrease the cost of construction .

The code change proposal will not increase or decrease the cost of construction because it is simply identifying another industry consensus standard (C448) to which existing materials PEX and PE-RT can comply.

Internal ID: 2164

M110-18

IMC: 1209.5, 1209.5.1, 1209.5.2

Proponent: Mike Fischer, Kellen Company, representing The Center for the Polyurethanes Industry of the American Chemistry Council (mfischer@kellencompany.com)

2018 International Mechanical Code

Revise as follows:

1209.5 ~~Thermal barrier~~ Insulation and thermal break required. Radiant floor heating systems shall be provided with insulation and a thermal barrier break in accordance with Sections 1209.5.1 and 1209.5.2. Insulation *R*-values for slab-on-grade and suspended floor installation shall be in accordance with the International Energy Conservation Code.

Exception: Insulation shall not be required in engineered systems where it can be demonstrated that the insulation will decrease the efficiency or have a negative effect on the installation.

1209.5.1 Thermal break required. A thermal break shall be provided consisting of asphalt expansion joint materials or similar insulating materials at a point where a heated slab meets a foundation wall or other conductive slab.

1209.5.2 ~~Thermal barrier~~ Insulation material marking. Insulating materials utilized in ~~thermal barriers~~ radiant floor heating systems shall be installed such that the manufacturer's *R*-value mark is readily observable upon inspection.

Reason:

This proposal is an editorial change that removes the term "thermal barrier" and replaces it with "thermal break" in Section 1209.5 of the IMC for radiant floor heating systems. The term "thermal barrier" refers to fire performance requirements; this section is focusing only on the requirement to insulate the floor system. "Thermal barrier" should be used only to describe the protection of a combustible materials from direct exposure to fire.

Cost Impact

The code change proposal will not increase or decrease the cost of construction .

The proposal is editorial in nature.

Internal ID: 1940

M111-18

IMC: SECTION 1209, 1209.1

Proponent: Michael Cudahy, representing self (mikec@cmservices.com)

2018 International Mechanical Code

SECTION 1209 EMBEDDED PIPING

Revise as follows:

1209.1 Materials. Piping for heating panels shall be standard-weight steel pipe, Type L copper tubing, polybutylene ~~or other approved~~ plastic pipe or tubing rated at 100 psi (689 kPa) at 180°F (82°C) ~~or plastic pipe or tubing that~~ complies with one of the standards in Table 605.4 of the International Plumbing Code.

Reason:

The language is unusual, and could be clearer in this section. Polybutylene is a plastic pipe and doesn't need to be specifically called out, and should be permitted if approved. Pipe used for hot water distribution like PE-RT should comply with the section, but so should materials like PVDF, which is not used in the hot water table. You should allow for all three of these example types. Maybe this needs it's own standards table.

Cost Impact

The code change proposal will not increase or decrease the cost of construction .

No cost increase is expected by either adding additional materials or the modification to the text.

Internal ID: 2049

M112-18

IMC: TABLE 1210.4, TABLE 1210.5, ordinal

Proponent: Jeremy Brown, representing NSF International (brown@nsf.org)

2018 International Mechanical Code

**TABLE 1210.4
GROUND-SOURCE LOOP PIPE**

MATERIAL	STANDARD (see Chapter 15)
Chlorinated polyvinyl chloride (CPVC)	ASTM D2846; ASTM F441; ASTM F442
Cross-linked polyethylene (PEX)	ASTM F876; CSA B137.5
Polyethylene/aluminum/polyethylene (PE-AL-PE) pressure pipe	ASTM F1282; CSA B137.9
High-density polyethylene (HDPE)	ASTM D2737; ASTM D3035; ASTM F714; AWWA C901; CSA B137.1; CSA C448; NSF 358-1
Polypropylene (PP-R)	ASTM F2389; CSA B137.11; NSF 358-2
Polyvinyl chloride (PVC)	ASTM D1785; ASTM D2241
Raised temperature polyethylene (PE-RT)	ASTM F2623; ASTM F2769; CSA B137.18, <u>NSF 358-4</u>

**TABLE 1210.5
GROUND-SOURCE LOOP PIPE FITTINGS**

PIPE MATERIAL	STANDARD (see Chapter 15)
Chlorinated polyvinyl chloride (CPVC)	ASTM D2846; ASTM F437; ASTM F438; ASTM F439; CSA B137.6
Cross-linked polyethylene (PEX)	ASTM F877; ASTM F1807; ASTM F1960; ASTM F2080; ASTM F2159; ASTM F2434; CSA B137.5
Polyethylene/aluminum/polyethylene (PE-AL-PE)	ASTM F1282; ASTM F2434; CSA B137.9
High Density Polyethylene (HDPE)	ASTM D2683; ASTM D3261; ASTM F1055; CSA B137.1; CSA C448; NSF 358-1
Polypropylene (PP-R)	ASTM F2389; CSA B137.11; NSF 358-2
Polyvinyl chloride (PVC)	ASTM D2464; ASTM D2466; ASTM D2467; CSA B137.2; CSA B137.3
Raised temperature polyethylene (PE-RT)	ASTM D3261; ASTM F1807; ASTM F2098; ASTM F2159; ASTM F2735; ASTM F2769; CSA B137.1; CSA B137.18. NSF 358-4

Add new standard(s) follows:

NSF

NSF International
789 N. Dixboro Road P.O. Box
130140
Ann Arbor MI 48105
US

NSF 358-4-2017:

Polyethylene of raised temperature (PE-RT) pipe and fittings for water-based ground-source (geothermal) heat pump systems

Reason:

At the proposal deadline, NSF 358-4 was still a draft standard, but it is expected to be published prior to the public hearing. The balloted draft standard will be submitted with the proposal. Anyone may receive a complimentary copy of this draft standard for the purpose of reviewing this proposal by emailing brown@nsf.org.

These tables contain the acceptable materials for geothermal ground loop pipe and fittings. PE-RT piping and associated fittings are already accepted materials with referenced standards. NSF 358-4 is a proposed ANSI standard written specifically to contain requirements for PE-RT geothermal piping and fittings. Companion standards NSF 358-1 (PE) and NSF 358-3(PP) are already approved in this table. NSF 358-4 addresses performance pressure testing, long term strength, chemical resistance, constant tensile load joint testing, suitability for burial and marking specific to geothermal PE-RT piping systems.

Cost Impact

The code change proposal will not increase or decrease the cost of construction .

Adding an additional option will not increase the cost of construction.

Analysis: A review of the standard proposed for inclusion in the code, with regard to the ICC criteria for referenced standards (Section 3.6 of CP#28) will be posted on the ICC website on or before April 2, 2018.

Internal ID: 1083

M113-18

IMC: TABLE 1210.4, TABLE 1210.5, ordinal

Proponent: Jeremy Brown, representing NSF International (brown@nsf.org)

2018 International Mechanical Code

Revise as follows:

**TABLE 1210.4
GROUND-SOURCE LOOP PIPE**

MATERIAL	STANDARD (see Chapter 15)
Chlorinated polyvinyl chloride (CPVC)	ASTM D2846; ASTM F441; ASTM F442
Cross-linked polyethylene (PEX)	ASTM F876; CSA B137.5, NSF 358-3
Polyethylene/aluminum/polyethylene (PE-AL-PE) pressure pipe	ASTM F1282; CSA B137.9
High-density polyethylene (HDPE)	ASTM D2737; ASTM D3035; ASTM F714; AWWA C901; CSA B137.1; CSA C448; NSF 358-1
Polypropylene (PP-R)	ASTM F2389; CSA B137.11; NSF 358-2
Polyvinyl chloride (PVC)	ASTM D1785; ASTM D2241
Raised temperature polyethylene (PE-RT)	ASTM F2623; ASTM F2769; CSA B137.18

**TABLE 1210.5
GROUND-SOURCE LOOP PIPE FITTINGS**

PIPE MATERIAL	STANDARD (see Chapter 15)
Chlorinated polyvinyl chloride (CPVC)	ASTM D2846; ASTM F437; ASTM F438; ASTM F439; CSA B137.6
Cross-linked polyethylene (PEX)	ASTM F877; ASTM F1807; ASTM F1960; ASTM F2080; ASTM F2159; ASTM F2434; CSA B137.5; <u>NSF 358-3</u>
Polyethylene/aluminum/polyethylene (PE-AL-PE)	ASTM F1282; ASTM F2434; CSA B137.9
High Density Polyethylene (HDPE)	ASTM D2683; ASTM D3261; ASTM F1055; CSA B137.1; CSA C448; NSF 358-1
Polypropylene (PP-R)	ASTM F2389; CSA B137.11; NSF 358-2
Polyvinyl chloride (PVC)	ASTM D2464; ASTM D2466; ASTM D2467; CSA B137.2; CSA B137.3
Raised temperature polyethylene (PE-RT)	ASTM D3261; ASTM F1807; ASTM F2098; ASTM F2159; ASTM F2735; ASTM F2769; CSA B137.1; CSA B137.18

Update standard(s) as follows:

NSF

NSF International
789 N. Dixboro Road P.O. Box
130140
Ann Arbor MI 48105
US

NSF 358-4-2017:

Polyethylene of raised temperature (PE-RT) pipe and fittings for water-based ground-source (geothermal) heat pump systems

Reason:

These tables contain the acceptable materials for geothermal ground loop pipe and fittings. PEX piping and associated fittings are already accepted materials with referenced standards. NSF 358-3 is an ANSI standard written specifically to contain requirements for PEX geothermal piping and fittings. Companion standards NSF 358-1

(PE) and NSF 358-3(PP) are already approved in this table. NSF 358-3 addresses performance pressure testing, long term strength, chemical resistance, constant tensile load joint testing, suitability for burial and marking specific to geothermal PEX piping systems. Anyone wishing to receive a complimentary copy of this standard for the purpose of reviewing this code change can send an email to brown@nsf.org

Cost Impact

The code change proposal will not increase or decrease the cost of construction .

This is adding an additional choice to the code which will not increase the cost of construction.

Analysis: A review of the standard proposed for inclusion in the code, with regard to the ICC criteria for referenced standards (Section 3.6 of CP#28) will be posted on the ICC website on or before April 2, 2018.

Internal ID: 1081

M114-18

IMC: TABLE 1202.4

Proponent: LANCE MacNevin, Plastic Pipe Institute, representing Plastics Pipe Institute (Imacnevin@plasticpipe.org)

2018 International Mechanical Code

Revise as follows:

**TABLE 1202.4
HYDRONIC PIPE**

MATERIAL	STANDARD (see Chapter 15)
Acrylonitrile butadiene styrene (ABS) plastic pipe	ASTM D1527; ASTM F2806
Chlorinated polyvinyl chloride (CPVC) plastic pipe	ASTM D2846; ASTM F441; ASTM F442
Copper or copper-alloy pipe	ASTM B42; ASTM B43; ASTM B302
Copper or copper-alloy tube (Type K, L or M)	ASTM B75; ASTM B88; ASTM B135; ASTM B251
Cross-linked polyethylene/aluminum/cross-linked polyethylene (PEX-AL-PEX) pressure pipe	ASTM F1281; CSA CAN/CSA-B-137.10
Cross-linked polyethylene (PEX) tubing	ASTM F876; <u>CSA B137.5</u>
Ductile iron pipe	AWWA C115/A21.15; AWWA C151/A21.51
Lead pipe	FS WW-P-325B
Polyethylene/aluminum/polyethylene (PE-AL-PE) pressure pipe	ASTM F1282; CSA B137.9
Polypropylene (PP) plastic pipe	ASTM F2389
Polyvinyl chloride (PVC) plastic pipe	ASTM D1785; ASTM D2241
Raised temperature polyethylene (PE-RT)	ASTM F2623; ASTM F2769; CSA B137.18
Steel pipe	ASTM A53; ASTM A106
Steel tubing	ASTM A254

Reason:

CSA B137.5 is the CSA standard for "Crosslinked Polyethylene Tubing Systems for Pressure Applications". The requirements of B137.5 are harmonized with ASTM F876 to be equivalent. CSA B137.5 is already listed in Table 1210.4 as equivalent to ASTM F876.

Cost Impact

The code change proposal will not increase or decrease the cost of construction .

adding B137.5 for PEX in Table 1202.4: The code change proposal will not increase or decrease the cost of construction because the same PEX tubing that already meets the requirements of the listed ASTM F876 will already meet the requirements of CSA B137.5; requirements are harmonized.

Internal ID: 2150

M115-18

IMC: Chapter 12, SECTION 1204, 1204.1, 1204.2

Proponent: Craig Dipetrillo, representing self (cjd@dipetrilloproperties.com)

2018 International Mechanical Code

CHAPTER 12 HYDRONIC PIPING

SECTION 1204 PIPE INSULATION

Revise as follows:

1204.1 Insulation characteristics. Pipe insulation installed in buildings shall conform to the requirements of the International Energy Conservation Code; shall be tested in accordance with ASTM E84 or UL 723, using the specimen preparation and mounting procedures of ASTM E2231; and shall have a maximum flame spread index of 25 and a smoke-developed index not exceeding 450. Insulation installed in an air *plenum* shall comply with Section 602.2.1. Pipe insulation shall be continuous except where the piping passes through a framing member.

Exception: The maximum flame spread index and smoke-developed index shall not apply to one- and two-family dwellings.

1204.2 Required thickness. Hydronic piping shall be insulated to the thickness required by the International Energy Conservation Code.

Reason:

The intent of the proposal is to have consistency where the code requires insulation of water piping "to be continuous".

Testimony:

SUBMITTAL FOR CONTINUOUS INSULATION

For the past 25 years I have been a Commissioner on the Rhode Island Building Code Standards Committee as both a member and chairman. During those years I have been the chairman or member of the Energy, Mechanical and Plumbing Subcommittees. I have been very pleased with the progress of the energy conservation in mechanical and plumbing systems especially relating to insulation of piping. The ICC has clearly recognized the importance of pipe insulation used for hot water conveyance. Over the years ICC has established requirements of insulation of piping and how to install the insulation to achieve maximum energy savings. Specifically, the requirement of continuous insulation through the hangers/supports as addressed in section C404.4 of the IECC. Upon discussions established by Craig DiPetrillo in regards to his findings of inconsistency, and during my research I have noticed that the IMC and IPC have not clearly delineated the continuous insulation (C404.4) requirement. I have asked Craig DiPetrillo to introduce an amendment to Section 607.5 to address this installation methodology.

Sincerely yours,

Gordon W. Preiss P. E., LEED AP

Rhode Island Building Code Standard Committee Commissioner

Westerly R. I. 02891

Cost Impact

The code change proposal will not increase or decrease the cost of construction .

The intent of the proposal is to have consistency where the code requires insulation of water piping "to be continuous".

Internal ID: 1484

M116-18

IMC: 1203.7

Proponent: Forest Hampton, Lubrizol Advanced Materials, Inc., representing Lubrizol Advanced Materials, Inc.
(forest.hampton@lubrizol.com)

2018 International Mechanical Code

Revise as follows:

1203.7 CPVC plastic pipe. Joints between CPVC plastic pipe or fittings shall be mechanical, solvent-cemented or threaded joints conforming to Section 1203.3.

Reason:

Section 1203.7 is being revised to add mechanical joints as an option with CPVC pipe.. Mechanical joints with CPVC pipe have a proven track record in the field and are allowed by the IPC.

Cost Impact

The code change proposal will not increase or decrease the cost of construction .

The addition of this widely used joining method will not increase the cost of construction as it only adds another option for the installer.

Internal ID: 1649

M117-18

IMC: 1210.6.2

Proponent: Gary Morgan, representing Viega LLC (gary.morgan@viega.us)

2018 International Mechanical Code

Revise as follows:

1210.6.2 Preparation of pipe ends. Pipe shall be cut square, ~~be reamed,~~ and be free of burrs and obstructions. ~~CPVC, PE, and PVC pipe shall be chamfered.~~ Pipe ends shall have full-bore openings and shall ~~not be undercut.~~ be prepared in accordance with manufacturer's instructions.

Reason:

This section is specific to plastic pipes and some of the existing language refers to terms such as "reamed" and "undercut" which only apply to metallic pipes. The revised language is more appropriate by including reference to preparing pipe ends in accordance with manufacturer's instructions which will be specific to that particular type of plastic pipe.

Cost Impact

The code change proposal will not increase or decrease the cost of construction .

This is only a clarification of existing language and will not result in any increased cost of construction.

Internal ID: 1826

M118-18

IMC: 1210.8

Proponent: Gary Morgan, representing Viega LLC (gary.morgan@viega.us)

2018 International Mechanical Code

Revise as follows:

1210.8 Installation. Piping, valves, fittings, and connections shall be installed in accordance with the ~~conditions of approval.~~ manufacturer's instructions.

Reason:

The existing language "...shall be installed in accordance with the conditions of approval." is not consistent with IMC language and unclear what that statement even means. This simple revision will make this section read perfectly consistent with the IRC's equivalent ground-source heat-pump system loop piping section , M2105.17 Installation.

For information Section M2105.17 of the IRC reads as follows:

M2105.17 Installation. Piping, valves, fittings, and connections shall be installed in accordance with the manufacturer's instructions.

Cost Impact

The code change proposal will not increase or decrease the cost of construction .

This editorial revision simply adds clarity and consistency to the statement and has no impacts on the costs of construction.

Internal ID: 1837

M119-18 Part I

IMC: 1209.1

Proponent: Chris Haldiman, representing Watts Water Technologies (chris.haldiman@wattswater.com)

THIS IS A 2 PART CODE CHANGE PROPOSAL. PART I WILL BE HEARD BY THE IMC COMMITTEE AND PART II WILL BE HEARD BY THE IRC M/P COMMITTEE. PLEASE SEE THE HEARING ORDERS FOR THESE COMMITTEES.

2018 International Mechanical Code

Revise as follows:

1209.1 Materials. Piping for heating panels shall be standard-weight steel pipe, Type L copper tubing, polybutylene or other *approved* plastic pipe or tubing rated at ~~100-80 psi (689 kPa)~~ 552kPa at 180°F (82°C).

Internal ID: 2160

M119-18 Part II

IRC: M2103.1

Proponent: Chris Haldiman, representing Watts Water Technologies (chris.haldiman@wattswater.com)

2018 International Residential Code

M2103.1 Piping materials. Piping for embedment in concrete or gypsum materials shall be standard-weight steel pipe, copper and copper-alloy pipe and tubing, cross-linked polyethylene/aluminum/cross-linked polyethylene (PEX-AL-PEX) pressure pipe, chlorinated polyvinyl chloride (CPVC), ~~polybutylene~~, cross-linked polyethylene (PEX) tubing, polyethylene of raised temperature (PE-RT) or polypropylene (PP) with a rating of not less than ~~100-80~~ psi at 180°F (~~690-552~~ kPa at 82°C).

Reason:

A 100 psi rating is not necessary in hydronic applications, particularly when the tubing is encased in a hard concrete or a gypsum material. Hydronic heating systems are typically designed with operating pressures of 12 psi - 20 psi, and these systems contain expansion tanks incorporated in them that are factory set to 12 psi. Safety relief valves on the boilers are typically set at 30 psi or 50 psi.

ASTM Standard F2623, "Standard Specification for Polyethylene of Raised Temperature (PE-RT) SDR 9 Tubing", states in Section 1.4, "The tubing produced under this specification shall be permitted for use in general fluid transport, including hydronics and irrigations systems."

I believe the retention of 100 psi minimum was an oversight when ASTM F2623 PE-RT was added to Table 1202.4.

Cost Impact

The code change proposal will not increase or decrease the cost of construction .

.It will not increase or decrease costs as the products used in hydronic applications are currently rated for 100 psi or 80 psi @180F. This will allow the use of products rated at 80 psi rated products to be used in embedded and not embedded systems.

Internal ID: 3413

M120-18

IMC: TABLE 1302.3, 1302.9 (New), ordinal, 15

Proponent: Bob Torbin, OmegaFlex, representing OmegaFlex (bob.torbin@omegaflex.net)

2018 International Mechanical Code

Revise as follows:

**TABLE 1302.3
FUEL OIL PIPING**

MATERIAL	STANDARD (see Chapter 15)
Copper or copper-alloy pipe	ASTM B42; ASTM B43; ASTM B302
Copper or copper-alloy tubing (Type K, L or M)	ASTM B75; ASTM B88; ASTM B280; ASME B16.51
Labeled pipe	(See Section 1302.4)
Nonmetallic pipe	ASTM D2996
Steel pipe	ASTM A53; ASTM A106
Steel tubing	ASTM A254; ASTM A539
Stainless steel tubing	ASTM A240; UL1369; UL971A

Add new text as follows:

1302.9 Corrugated stainless steel tubing containment system. Corrugated stainless steel tubing that is factory-installed within a non-metallic containment system shall be listed and labeled in accordance with UL 1369 or UL 971A.

Add new standard(s) follows:

ASTM

ASTM International
100 Barr Harbor Drive, P.O. Box
C700
West Conshohocken PA 19428
US

A240/A240M- 15a:

Standard Specification for Chromium and Chromium-nickel Stainless Steel Plate, Sheet and Strip for Pressure Vessels and for General Applications

UL

UL LLC
333 Pfingsten Road
Northbrook IL 60062-2096
US

971A-2006:

Outline of Investigation for Metallic Underground Fuel Pipe

Reason:

The corrugated stainless steel tubing double-containment system, including termination fittings, is intended for use with fuel oil, as well as motor vehicle, aviation and marine fuels either above or below grade. The intent and design of double containment systems are focused on preventing fuel oil leaks that could result in severe fire hazards.

The corrugated stainless steel primary tubing is a zero-permeation pipe which is highly resistant to corrosion with exceptional crush resistance. The UV stabilized Nylon 12 protective containment layer offers exceptional resistance to hydrocarbons, chemical and water exposure, and carries a 50 psig rating. An EFEP secondary barrier jacket layer is bonded to the Nylon 12 protective layer to offer secondary containment with exceptional permeation resistance for product compatibility. The interstitial space between the tubing and jacket allows continuous monitoring for leak detection, with a 50 psig rating for pressurized systems. The self-flaring fitting provides a metal to metal sealing surface with excellent reliability and is field-attachable using standard hand tools. This class of piping product has been used for a variety of fuels for several years without failure, and is also permitted in the IFGC for similar applications for fuel gas systems (see Section 404.14).

Cost Impact

The code change proposal will decrease the cost of construction .

The use of a listed encasement system results in cost savings because the piping and encasement are installed simultaneously. This avoids the labor cost of separately installing the conduit and piping. In addition, the sealing and venting methods (when required) are also integrated within the encasement system, thus eliminating the need to separately assemble and/or install sealing and venting components within standard conduit.

M121-18

IMC: Chapter 13, SECTION 1301, 1301.1, 1301.2, 1301.3, 1301.4, 1301.5, SECTION 1302, 1302.1, 1302.2, TABLE 1302.3, 1302.3, 1302.4, 1302.5, 1302.6, 1302.7, 1302.8, SECTION 1303, 1303.1, 1303.1.1, 1303.2, 1303.3, 1303.3.1, 1303.3.2, 1303.3.3, 1303.3.4, 1303.3.5 (New), 1303.4, 1303.5, 1303.6, 1303.7, 1303.7.1, 1303.8, 1303.9, 15

Proponent: Mark Fasel, representing Viega LLC (mark.fasel@viega.us)

2018 International Mechanical Code

CHAPTER 13 FUEL OIL PIPING AND STORAGE

SECTION 1301 GENERAL

1301.1 Scope. This chapter shall govern the design, installation, construction and repair of fuel-oil storage and piping systems. The storage of fuel oil and flammable and combustible liquids shall be in accordance with Chapters 6 and 57 of the International Fire Code.

1301.2 Storage and piping systems. Fuel-oil storage systems shall comply with Section 603.3 of the International Fire Code. Fuel-oil piping systems shall comply with the requirements of this code.

1301.3 Fuel type. An *appliance* shall be designed for use with the type of fuel to which it will be connected. Such *appliance* shall not be converted from the fuel specified on the rating plate for use with a different fuel without securing reapproval from the code official.

Revise as follows:

1301.4 Fuel tanks, piping, fittings and valves. The tank, piping, fittings and valves for appliances burning oil shall be installed in accordance with the requirements of this chapter. Where an oil burner is served by a tank, any part of which is above the level of the burner inlet connection and where the fuel supply line is taken from the top of the tank, an *approved* antisiphon valve or other siphon-breaking device shall be installed in lieu of the shutoff valve.

1301.5 Tanks abandoned or removed. All exterior above-grade fill piping shall be removed when tanks are abandoned or removed. Tank abandonment and removal shall be in accordance with Section 5704.2.13 of the International Fire Code.

SECTION 1302 MATERIAL

1302.1 General. Piping materials shall conform to the standards cited in this section.

1302.2 Rated for system. All materials shall be rated for the operating temperatures and pressures of the system, and shall be compatible with the type of liquid.

**TABLE 1302.3
FUEL OIL PIPING AND FITTINGS**

MATERIAL	STANDARD (see Chapter 15)
Copper or copper-alloy pipe <u>and fittings</u>	ASTM B42; ASTM B43; ASTM B302; <u>ASTM F3226</u>
Copper or copper-alloy tubing <u>and fittings</u> (Type K, L or M)	ASTM B75; ASTM B88; ASTM B280; ASME B16.51; <u>ASTM F3226</u>
Labeled pipe	(See Section 1302.4)
Nonmetallic pipe	ASTM D2996
Steel <u>and Stainless Steel</u> pipe <u>and fittings</u>	ASTM A53; ASTM A106; <u>ASTM A312</u> ; <u>ASTM F3226</u>
Steel <u>and Stainless Steel</u> tubing <u>and fittings</u>	ASTM A254; ASTM A539; <u>ASTM A269</u> ; <u>ASTM F3226</u>

1302.3 Pipe standards. Fuel oil pipe shall comply with one of the standards listed in Table 1302.3.

1302.4 Nonmetallic pipe. Nonmetallic pipe shall be *listed* and *labeled* as being acceptable for the intended application for flammable and combustible liquids. Nonmetallic pipe shall be installed only outdoors, underground.

1302.5 Fittings and valves. Fittings and valves shall be *approved* for the piping systems, and shall be compatible with, or shall be of the same material as, the pipe or tubing.

1302.6 Bending of pipe. Pipe shall be *approved* for bending. Pipe bends shall be made with *approved equipment*. The bend shall not exceed the structural limitations of the pipe.

1302.7 Pumps. Pumps that are not part of an *appliance* shall be of a positive-displacement type. The pump shall automatically shut off the supply when not in operation. Pumps shall be *listed* and *labeled* in accordance with UL 343.

1302.8 Flexible connectors and hoses. Flexible connectors and hoses shall be *listed* and *labeled* in accordance with UL 536.

SECTION 1303 JOINTS AND CONNECTIONS

1303.1 Approval. Joints and connections shall be *approved* and of a type *approved* for fuel-oil piping systems. Threaded joints and connections shall be made tight with suitable lubricant or pipe compound. Unions requiring gaskets or packings, right or left couplings, and sweat fittings employing solder having a melting point of less than 1,000°F (538°C) shall not be used in oil lines. Cast-iron fittings shall not be used. Joints and connections shall be tight for the pressure required by test.

1303.1.1 Joints between different piping materials. Joints between different piping materials shall be made with *approved* adapter fittings. Joints between different metallic piping materials shall be made with *approved* dielectric fittings or copper-alloy converter fittings.

1303.2 Preparation of pipe ends. Pipe shall be cut square, reamed and chamfered and be free from all burrs and obstructions. Pipe ends shall have full-bore openings and shall not be undercut.

1303.3 Joint preparation and installation. Where required by Sections 1303.4 through 1303.9, the preparation and installation of brazed, mechanical, threaded, press-connect and welded joints shall comply with Sections 1303.3.1 through ~~1303.3.4-1303.3.5~~.

1303.3.1 Brazed joints. All joint surfaces shall be cleaned. An *approved* flux shall be applied where required. The joints shall be brazed with a filler metal conforming to AWS A5.8.

1303.3.2 Mechanical joints. Mechanical joints shall be installed in accordance with the manufacturer's instructions. ~~Press-connect joints shall conform to one of the standards listed in Table 1302.3.~~

1303.3.3 Threaded joints. Threads shall conform to ASME B1.20.1. Pipe-joint compound or tape shall be applied on the male threads only.

1303.3.4 Welded joints. All joint surfaces shall be cleaned by an *approved* procedure. The joint shall be welded with an *approved* filler metal.

1303.3.5 Press-Connect joints. Press-Connect joints shall be installed in accordance with the manufacturer's

instructions and shall conform to one of the standards listed in Table 1302.3.

1303.4 Copper or copper-alloy pipe. Joints between copper or copper-alloy pipe or fittings shall be brazed, mechanical, threaded, press-connect or welded joints complying with Section 1303.3.

1303.5 Copper or copper-alloy tubing. Joints between copper or copper-alloy tubing or fittings shall be brazed, mechanical joints ~~complying with Section 1303.3, or press-connect joints that conform to one of the standards in Table 1302.3~~ or flared joints. Flared joints shall be made by a tool designed for that operation complying with Section 1303.3.

1303.6 Nonmetallic pipe. Joints between nonmetallic pipe or fittings shall be installed in accordance with the manufacturer's instructions for the *labeled* pipe and fittings.

1303.7 Steel and Stainless Steel pipe. Joints between steel or stainless steel pipe or fittings shall be threaded, press-connect or welded joints complying with Section 1303.3 or mechanical joints complying with Section 1303.7.1.

1303.7.1 Mechanical joints. Joints shall be made with an *approved* elastomeric seal. Mechanical joints shall be installed in accordance with the manufacturer's instructions. Mechanical joints shall be installed outdoors, underground, unless otherwise *approved*.

1303.8 Steel and Stainless Steel tubing. Joints between steel or stainless steel tubing or fittings shall be mechanical, press-connect or welded joints complying with Section 1303.3.

1303.9 Piping protection. Proper allowance shall be made for expansion, contraction, jarring and vibration. Piping other than tubing, connected to underground tanks, except straight fill lines and test wells, shall be provided with flexible connectors, or otherwise arranged to permit the tanks to settle without impairing the tightness of the piping connections.

Add new standard(s) follows:

ASTM

ASTM International
100 Barr Harbor Drive, P.O. Box
C700
West Conshohocken PA 19428

A269-15:

Standard Specification for Seamless and Welded Austenitic Stainless Steel Tubing for General Service

A312-17:

Standard Specification for Seamless, Welded, and Heavily Cold Worked Austenitic Stainless Steel Pipes

F3226-16:

Standard Specification for Metallic Press-Connect Fittings for Piping and Tubing Systems

Reason:

Revisions for Chapter 13 have been included in one proposal for better discussion. Reason Statements will be provided under each Section number with proposed revisions.

Section 1301.4-proposed to include fittings in this section for consistency throughout the chapter.

Table 1302.3-Proposed revisions to this table include updating the Title to include both Pipe and Fittings. Currently fitting standards exist in this table. The proposed table revision includes the addition of ASTM F3226 (Press-connect fitting standard for copper, steel and stainless steel) which was recently published. ASTM A269 (stainless steel tubing standard) which is referenced in NFPA 31 and is recognized as acceptable for use in heating oil piping. Stainless steel tubing has been requested to be used due to its corrosion resistance properties. ASTM A312 (stainless steel pipe) is referenced for use in CSA B139 Installation code for Oil Burning Equipment.

Section 1303.3- this section adds press-connect joints in a new subsection 1303.3.5 and revises the section to state joints shall comply with sections 1303.3.1 through 1303.3.5.

Section 1303.3.2-Press-Connect joints have their own definition in the Chapter 2 of International Mechanical Code and needs to be uniquely identified from that of a Mechanical joint. The Mechanical Joint Definition does not exclude press-connect joints, but they are not listed under examples as types of joints see Chapter 2 definition below:

MECHANICAL JOINT.

1. A connection between pipes, fittings, or pipes and fittings that is not welded, brazed, caulked, soldered, solvent cemented or heat fused.

2. A general form of gas or liquid-tight connections obtained by the joining of parts through a positive holding mechanical construction such as, but not limited to, flanged, screwed, clamped or flared connections.

Section 1303.3.5-Press-Connect joints have their own definition in the Chapter 2 of International Mechanical Code and needs to be uniquely identified from that of a Mechanical joint.

PRESS-CONNECT JOINT. A permanent mechanical joint incorporating an elastomeric seal or an elastomeric seal and corrosion-resistant grip ring. The joint is made with a pressing tool and jaw or ring approved by the fitting manufacture.

Section 1303.4- this revision adds press-connect joints to acceptable copper or copper alloy pipe. The standard for press-connect fittings for use with copper or copper alloy pipe is ASTM F3226 which is included in Table 1302.2.

Section 1303.5- this proposed revision cleans up unnecessary language. All of the recognized joints are listed in subsections 1303.3.1 through 1303.3.5. The removal of the language referring press-connect joints to Table 1302.3 and is not needed as this is the requirement under Section 1303.3 Joint preparation and installation. Flared fittings are included in the definition of Mechanical joints and do not need to be specifically identified in this section. See definition of Mechanical joint below:

MECHANICAL JOINT.

1. A connection between pipes, fittings, or pipes and fittings that is not welded, brazed, caulked, soldered, solvent cemented or heat fused.

2. A general form of gas or liquid-tight connections obtained by the joining of parts through a positive holding mechanical construction such as, but not limited to, flanged, screwed, clamped or flared connections.

Section 1303.7-Stainless steel pipe is suitable for use in these systems and referenced as an acceptable piping material in CSA B139 Installation of Oil Fired Equipment Code section 5.2.1.2. This material has been specified due to its corrosion resistance properties.

Section 1303.8-NFPA 31 section 8.2.2.1 currently allows the use of stainless steel tubing. Stainless steel tubing is being specified on projects due to its corrosion-resistance properties and its compatibility as a piping material for fuel oil. Press-connect fittings are made for stainless steel piping and tubing and are already referenced in Chapter 13 of this code. Table 1302.3 has been proposed to be updated to add the stainless steel tubing and press-connect fitting standards ASTM A269 and ASTM F3226.

Chapter 15 Reference Standards- The standards proposed in Table 1302.3 that are not currently listed in Chapter 15 have been proposed to be added:

ASTM A269-15

Standard Specification for Seamless and Welded Austenitic Stainless Steel Tubing for General Service

ASTM A312-17

Standard Specification for Seamless, Welded, and Heavily Cold Worked Austenitic Stainless Steel Pipes

ASTM F3226-16

Standard Specification for Metallic Press-Connect Fittings for Piping and Tubing Systems

Cost Impact

The code change proposal will not increase or decrease the cost of construction .

These proposals provide an alternative to the existing pipe joining methods. The standards listed for Press-Connect type joints and stainless steel pipe are based on the alloys used and again are optional. No existing metallic alloys or joining methods are being removed as a result there are not costs associated with the proposed changes.

Analysis: A review of the standard proposed for inclusion in the code, with regard to the ICC criteria for referenced standards (Section 3.6 of CP#28) will be posted on the ICC website on or before April 2, 2018.

Internal ID: 909

M122-18

IMC: 1303.7

Proponent: Mark Fasel, representing Viega LLC (mark.fasel@viega.us)

2018 International Mechanical Code

Revise as follows:

1303.7 Steel and Stainless Steel pipe. Joints between steel or stainless steel pipe or fittings shall be threaded, press-connected or welded joints complying with Section 1303.3 or mechanical joints complying with Section 1303.7.1.

Reason:

Stainless steel pipe is suitable for use in these systems and referenced in CSA B139 Installation of Oil Fired Equipment Code. This material has been specified due to its corrosion resistance properties.

Cost Impact

The code change proposal will not increase or decrease the cost of construction .

This proposal includes stainless steel and press-connect fittings as alternates to existing steel and existing threaded or welded type connections. Since these are considered alternate to the existing there are no cost increases associated with this proposal..

Internal ID: 895

M123-18

IMC: TABLE 1302.3, ordinal

Proponent: Mark Fasel, representing Viega LLC (mark.fasel@viega.us)

2018 International Mechanical Code

Revise as follows:

**TABLE 1302.3
FUEL OIL PIPING AND FITTINGS**

MATERIAL	STANDARD (see Chapter 15)
Copper or copper-alloy pipe <u>and fittings</u>	ASTM B42; ASTM B43; ASTM B302; <u>ASTM F3226</u>
Copper or copper-alloy tubing <u>and fittings</u> (Type K, L or M)	ASTM B75; ASTM B88; ASTM B280; ASME B16.51; <u>ASTM F3226</u>
Labeled pipe	(See Section 1302.4)
Nonmetallic pipe	ASTM D2996
Steel <u>and Stainless Steel</u> pipe <u>and fittings</u>	ASTM A53; ASTM A106; <u>ASTM A312</u> ; <u>ASTM F3226</u>
Steel <u>and Stainless Steel</u> tubing <u>and fittings</u>	ASTM A254; ASTM A539; <u>ASTM A269</u> ; <u>ASTM F3226</u>

Add new standard(s) follows:

ASTM

ASTM International
100 Barr Harbor Drive, P.O. Box
C700
West Conshohocken PA 19428
US

F3226-16:

Standard Specification for Metallic Press-Connect Fittings for Piping and Tubing Systems

Reason:

Proposed revisions to this table include updating the Title to include both Pipe and Fittings. Currently there are fitting standards existing in this table. The proposed table revision includes the addition of ASTM F3226 (Press-connect fitting standard for copper, steel and stainless steel) which was recently published. ASTM A269 (stainless steel tubing standard) which is referenced in NFPA 31 and is recognized as acceptable for use in heating oil piping. Stainless steel tubing has been requested to be used due to its corrosion resistance properties. ASTM A312 (stainless steel pipe) is referenced for use in CSA B139 Installation code for Oil Burning Equipment.

Cost Impact

The code change proposal will not increase or decrease the cost of construction .

This proposal to update to the table with the mentioned standards simply allows for additional piping and connection options and does not remove any existing standards and therefore will not increase the cost of construction.

Analysis: A review of the standard proposed for inclusion in the code, with regard to the ICC criteria for referenced standards (Section 3.6 of CP#28) will be posted on the ICC website on or before April 2, 2018.

Internal ID: 875

M124-18

IMC: 1303.8

Proponent: Mark Fasel, representing Viega LLC (mark.fasel@viega.us)

2018 International Mechanical Code

Revise as follows:

1303.8 Steel and Stainless Steel tubing. Joints between steel or stainless steel tubing or fittings shall be mechanical, press-connected or welded joints complying with Section 1303.3.

Reason:

NFPA 31 section 8.2.2.1 currently allows the use of stainless steel tubing. Stainless steel tubing is being specified on projects due to its corrosion-resistance properties and its compatibility as a piping material for fuel oil. Press-connect fittings are made for stainless steel piping and tubing and are already referenced in Chapter 13 of this code.

Cost Impact

The code change proposal will not increase or decrease the cost of construction .

This proposal includes stainless steel tubing and press-connect fittings as alternates to existing steel tubing and existing mechanical or welded type connections. Since these are considered alternate to the existing there are no cost increases associated with this proposal.

Internal ID: 860

M125-18

IMC: 1303.7

Proponent: Mark Fasel, representing Viega LLC (mark.fasel@viega.us)

2018 International Mechanical Code

Revise as follows:

1303.7 Steel pipe. Joints between steel pipe or fittings shall be threaded, press-connected or welded joints complying with Section 1303.3 or mechanical joints complying with Section 1303.7.1.

Reason:

Press-connect fittings are referenced in Chapter 13 of this code and this proposal includes them as a joining method for steel pipe.

Cost Impact

The code change proposal will not increase or decrease the cost of construction .

The inclusion of press-connected fittings in addition to the existing joining methods currently allowed do not increase cost as they are just another option for pipe joining methods and are not required to be used.

Internal ID: 859

M126-18

IMC: TABLE 1302.3

Proponent: Mark Fasel, representing Viega LLC (mark.fasel@viega.us)

2018 International Mechanical Code

Revise as follows:

**TABLE 1302.3
FUEL OIL PIPING**

MATERIAL	STANDARD (see Chapter 15)
Copper or copper-alloy pipe	ASTM B42; ASTM B43; ASTM B302
Copper or copper-alloy tubing (Type K, L or M)	ASTM B75; ASTM B88; ASTM B280; ASME B16.51
Labeled pipe	(See Section 1302.4)
Nonmetallic pipe	ASTM D2996
Steel pipe	ASTM A53; ASTM A106
Steel tubing	ASTM A254; ASTM A539
<u>Stainless Steel tubing</u>	<u>ASTM A254; ASTM A269;</u>

Reason:

NFPA 31 section 8.2.2.1 currently allows the use of stainless steel tubing. Stainless steel tubing is being specified on projects due to its corrosion-resistance properties and its compatibility as a piping material for fuel oil.

Bibliography:

NFPA 31 Standard for Installation of Oil-Burning Equipment
 Chapter 8 Heating Fuel Piping Systems and Components Section 8.2.2.1
 National Fire Protection Agency
 2016

Cost Impact

The code change proposal will not increase or decrease the cost of construction .

The inclusion of stainless steel tubing and the related standards are optional and are not required to be used. Being this addition is optional, it will not increase the cost of construction as the existing materials may continue to be used and are not being eliminated.

Analysis: A review of the standard proposed for inclusion in the code, with regard to the ICC criteria for referenced standards (Section 3.6 of CP#28) will be posted on the ICC website on or before April 2, 2018.

Internal ID: 801

M127-18

IMC: 1402.8.1.2

Proponent: Lee Kranz, representing Washington Association of Building Officials Technical Code Development Committee (lkranz@bellevuewa.gov); Angela Haupt (AHaupt@kirklandwa.gov)

2018 International Mechanical Code

Revise as follows:

1402.8.1.2 Rooftop-mounted solar thermal collectors and systems. The roof shall be constructed to support the loads imposed by roof-mounted solar collectors. Where mounted on or above the roof covering, the collector array ~~and supporting construction, stanchions and their attachments to the roof~~ shall be constructed of noncombustible materials or fire-retardant-treated wood conforming to the International Building Code to the extent required for the type of roof construction of the building to which the collectors are accessory.

Reason:

This code change clarifies that roof mounted solar collectors, the supports between the collectors and the roof (for example, sleepers, curbs and stanchions), and the attachments to the roof are required to be of non-combustible materials or FRT wood. The current text could be misinterpreted to mean that the entire roof assembly supporting the collectors and associated equipment, even if allowed to be of combustible materials by other provisions of the code, needs to be noncombustible materials or FRT which is not the case.

Cost Impact

The code change proposal will not increase or decrease the cost of construction .

Clarrification only.

Internal ID: 249

M128-18

IMC: 1404.1

Proponent: Joseph Cain, Solar Energy Industries Association (SEIA), representing Solar Energy Industries Association (JoeCainPE@gmail.com)

2018 International Mechanical Code

Revise as follows:

1404.1 Collectors. Factory-built ~~solar thermal~~ collectors shall bear a label showing the manufacturer's name and address, ~~model number and serial number or certification number.~~

Reason:

The current language is inconsistent with labeling requirements of SRCC OG-100 labels. The proposed revision is to change the language to be consistent with SRCC OG-100 labels.

Cost Impact

The code change proposal will not increase or decrease the cost of construction .

This proposal includes editorial changes only.

Internal ID: 1994

2018 GROUP A – PROPOSED CHANGES TO THE INTERNATIONAL PLUMBING CODE

PLUMBING CODE COMMITTEE

Charles E. Gerber, *Chair*
Plumbing Plans Reviewer
County of Henrico
Henrico, VA

James C. Finley, PE, *Vice Chair*
Rep: Plumbing-Heating-Cooling Contractors
Association
President
C.N. Finley, Inc.
Destrehan, LA

Joseph Ackroyd, PE
Executive Director
New York City Department of Buildings
New York, NY

Michael Cudahy
Regulations and Sustainability Specialist
Plastic Pipe and Fittings Association
Glen Ellyn, IL

Scott J. Friesen, PE
Principal Consultant
Ivey Engineering, Inc.
San Diego, CA

McKenzie W. James
Chief Plumbing Inspector
City of Portland, Oregon
Portland, OR

Walt Krzyanowski
President/Executive Director
Plumbing & Heating Contractors Union
Affiliated Contractors, Local #690
Feasterville, PA

Joseph T. Madziar
Retired
State of Michigan
Lansing, MI

James Meyer
Vice President of Engineering
Norweco, Inc.
Norwalk, OH

James Pappas, CBO
Senior Plans Examiner
City of Scottsdale
Scottsdale, AZ

John A. Robitaille, CBO
Rep: Remington, Vernick and Beach Engineers
Construction Code Official
Wilmington, DE

James A. Richardson, Jr.
Plumbing Inspection Supervisor
City of Columbus-Building and Zoning Services
Columbus, OH

Matt Sigler
Technical Director
Plumbing Manufacturers International
Orlando, FL

John William Tye III, SMI
Construction Services Building Official,
State Mechanical Inspector
State of Connecticut Office of the State Building
Inspector
Hartford, CT

Gary Wickham
Senior Technical Manager, Codes and
Standards
AB&I Foundry
Oakland, CA

Staff Secretariat:
Fred Grable, PE
Senior Staff Engineer - Plumbing
International Code Council
Central Regional Office
Country Club Hills, IL

TENTATIVE ORDER OF DISCUSSION 2018 PROPOSED CHANGES TO THE INTERNATIONAL PLUMBING CODE

The following is the tentative order in which the proposed changes to the code will be discussed at the public hearings. Proposed changes which impact the same subject have been grouped to permit consideration in consecutive changes.

Proposed change numbers that are indented are those which are being heard out of numerical order. Indentation does not necessarily indicate that one change is related to another. Proposed changes may be grouped for purposes of discussion at the hearing at the discretion of the chair. Note that some P code change proposals may not be included on this list, as they are being heard by another committee.

IPSDC

PSD 1 -18
PSD 2 -18
PSD 3 -18
PSD 4 -18
PSD 5 -18
PSD 6 -18
 P1-18 Part VI

P26-18
P27-18
 G134-18
P28-18
P29-18
P30-18
P31-18
P32-18
P33-18 Part I

P62-18
P63-18 Part I
P64-18
P65-18
P66-18
P67-18
P68-18
P69-18
P70-18

P100-18
P101-18
P102-18
P103-18 Part I
P104-18
P105-18
P106-18 Part I
P107-18 Part I
P108-18

IPC

P1-18 Part I
P2-18
P3-18
P4-18
P5-18
P6-18
P7-18 Part I
P8-18 Part I
P9-18
P10-18
P11-18 Part I
P12-18
P13-18
P14-18
P15-18
P16-18
P17-18
P18-18
P19-18
P20-18 Part I
P20-18 Part II
P21-18
 G132-18
P22-18 Part I
P22-18 Part II
P23-18
P24-18
P25-18

P34-18
P35-18
P36-18
P37-18
P38-18 Part I
P38-18 Part II
P39-18
P40-18
P41-18
P42-18
P43-18
P44-18 Part I
P45-18 Part I
P46-18 Part I
P47-18 Part I
P48-18 Part I
P49-18
P50-18 Part I
P51-18
P52-18
P53-18
P54-18
P55-18
P56-18
P57-18
P58-18 Part I
P59-18
P60-18
P61-18

P71-18 Part I
P72-18
P73-18
P74-18
P75-18
P76-18
P77-18 Part I
P78-18
P79-18 Part I
P80-18
P81-18
P82-18 Part I
P83-18
P84-18
P85-18
P86-18
P87-18 Part I
P88-18 Part I
P89-18 Part I
P90-18
P91-18
P92-18
P93-18
P94-18
P95-18
P96-18
P97-18 Part I
P98-18 Part I
P99-18

P109-18 Part I
P110-18
P111-18
P112-18
P113-18 Part I
P114-18
P115-18 Part I
P116-18
P117-18
P118-18
P119-18
P120-18
P121-18
P122-18
P123-18
P124-18
P125-18
P126-18
P127-18
P128-18
P129-18
P130-18
 S1-18
P131-18 Part I
P132-18 Part I
P133-18 Part I

P1-18 Part I

IPC: 202 (New)

Proponent: Pennie L Feehan, Pennie L. Feehan Consulting, representing Copper Development Association (penniefeehan@me.com)

THIS IS A 6 PART CODE CHANGE PROPOSAL. PARTS I and VI WILL BE HEARD BY THE IPC-IPSDC COMMITTEE. PART II WILL BE HEARD BY THE IRC-PLUMBING COMMITTEE. PART III WILL BE HEARD BY THE IMC COMMITTEE. PART IV WILL BE HEARD BY THE IFGC COMMITTEE. PART V WILL BE HEARD BY THE ISPSC COMMITTEE. SEE THE TENTATIVE HEARING ORDERS FOR THESE COMMITTEES.

2018 International Plumbing Code

Add new definition as follows:

COPPER ALLOY. A homogeneous mixture of not less than two metals where not less than 50% of the finished metal is copper.

Internal ID: 1595

P1-18 Part II

IRC: R202

Proponent: Pennie L Feehan, Pennie L. Feehan Consulting, representing Copper Development Association (penniefeehan@me.com)

2018 International Residential Code

Add new definition as follows:

COPPER ALLOY. A homogeneous mixture of not less than two metals where not less than 50% of the finished metal is copper.

Internal ID: 1599

P1-18 Part III

IMC: 202 (New)

Proponent: Pennie L Feehan, Pennie L. Feehan Consulting, representing Copper Development Association (penniefeehan@me.com)

2018 International Mechanical Code

Add new definition as follows:

COPPER ALLOY. A homogeneous mixture of not less than two metals where not less than 50% of the finished metal is copper.

Internal ID: 1590

P1-18 Part IV

IFGC: 202 (New)

Proponent: Pennie L Feehan, Pennie L. Feehan Consulting, representing Copper Development Association (penniefeehan@me.com)

2018 International Fuel Gas Code

Add new definition as follows:

COPPER ALLOY. A homogeneous mixture of not less than two metals where not less than 50% of the finished metal is copper.

Internal ID: 1587

P1-18 Part V

ISPSC: 202 (New)

Proponent: Pennie L Feehan, Pennie L. Feehan Consulting, representing Copper Development Association (penniefeehan@me.com)

2018 International Swimming Pool and Spa Code

Add new definition as follows:

COPPER ALLOY. A homogeneous mixture of not less than two metals where not less than 50% of the finished metal is copper.

Internal ID: 1602

P1-18 Part VI

IPSDC: 202 (New)

Proponent: Pennie L Feehan, representing Copper Development Association (penniefeehan@me.com)

2018 International Private Sewage Disposal Code

Add new definition as follows:

COPPER ALLOY. A homogeneous mixture of not less than two metals where not less than 50% of the finished metal is copper.

Reason:

It is important to understand that copper tube is an almost pure copper alloy, composed of 99.9% Cu + Ag combined with no greater than 0.04% P. Whereas, a copper alloy is a mixture of at least two metals in which copper is the primary component comprising no less than 50% and is combined with other elements to create different copper alloys. Therefore, brass, bronze, red brass, etc. are all forms of Copper Alloy.

Cost Impact

The code change proposal will not increase or decrease the cost of construction .

This change only clarifies the code and doesn't impact the costs of labor or materials of construction.

Internal ID: 3126

P2-18

IPC: 202

Proponent: Gary Klein, Gary Klein and Associates, Inc., representing Self (gsmklein@comcast.net)

2018 International Plumbing Code

Revise as follows:

PUBLIC OR PUBLIC UTILIZATION. ~~In the classification of plumbing fixtures, “public” applies to fixtures in general toilet rooms of schools, gymnasiums, hotels, airports, bus and railroad stations, public buildings, bars, public comfort stations, office buildings, stadiums, stores, restaurants and other installations where a number of fixtures are installed so that their utilization is similarly unrestricted with unrestricted exposure to walk-in traffic.~~

PRIVATE. ~~In the classification of plumbing fixtures, “private” applies to fixtures in residences and apartments, and to fixtures in nonpublic toilet rooms of hotels and motels and similar installations in buildings where the plumbing fixtures are intended for utilization by a family or an individual that are not public.~~

Reason:

The purpose of this code change proposal is to clarify the distinction between private and public or public utilization.

The current definitions of private and public or public utilization are confusing to many who are responsible for implementing the IPC. This proposal attempts to simplify the two definitions by clearly defining one category and then stating that the other one is everything else. We have chosen to define public or public utilization.

The word “unrestricted” comes from ASME 112.18.1-2005¹ The wording “exposure to walk-in traffic” comes from ASME 112.18.1-2012/CSA B125.1-12. That document, referenced in the IPC and other I-codes, has a definition for “**Public Lavatory Fitting**— a fitting intended to be installed in non-residential bathrooms that are exposed to walk-in traffic.”² ANSI/ASHRAE/IES Standard 90.1-2016 supports this concept with the following definition: “**Public facility restroom** - a restroom used by the transient public.”³ Transient is used instead of walk-in traffic. We preferred “walk-in “ to “transient”, but either can work. It was our intent that using the same wording for a similar purpose helps to correlate the codes.

We believe that there are two key distinctions to make between public and private toilet facilities: level of access and frequency of use. “Public” toilet facilities are those with unrestricted access to anyone who enters the building. These toilet facilities are also likely to be used frequently throughout the hours of operation of each occupancy type. Some examples of these are: toilet facilities in airports, assembly occupancies such as stadiums and theaters, restaurants and other food service facilities, and in the lobbies of any non-residential building including public buildings, office buildings, manufacturing facilities, mercantile facilities and military facilities that have unrestricted access to walk-in traffic. Using both terms, “unrestricted” and “walk-in traffic” in the definition captures our intent for this code change proposal.

All other toilet facilities would then be considered private: those inside residences, hotel and motel rooms, patient rooms, and toilet facilities that are not in the lobbies of non-residential buildings. Their use is restricted to those who reside in or work in the occupancy. These toilet facilities are “private”.

The distinction is important because there are different requirements for public and private lavatories. Two such requirements come to mind: water temperature and flow rate. Currently, in the I-codes, private lavatories are required to be supplied with hot water; public lavatories are not. (See the table below) In addition, the flow rate for public lavatory faucets is limited to a maximum of 0.5 gpm or 0.25 gallons per cycle for metered faucets. (See Table 604.4 in the 2018 IPC. These values are taken from the Energy Policy Act (EPAAct) and have been a federal requirement since the 1990s.) Distinguishing more clearly between public and private toilet facilities will make it easier to explain why public lavatory faucets get the flow rates they do.

Adopting the proposed change to these definitions protects health and safety at least as well as the current definitions.

What follows is the reason statement that supports several change proposals. There is one reason statement for these proposals because the topics are interrelated and a comprehensive discussion is most likely to result in the best outcome for protecting the public’s health and safety

Health and safety for public hand washing needs to include 1) scald prevention, 2) hand washing efficacy and 3) minimizing the risk of pathogen growth in the building’s water distribution system.

We do not want the temperature of the water at public sinks to be too hot. We want the temperature of the water to

be comfortable for the users of public sinks so that people will scrub their hands long enough to get them clean. We want to reduce the likelihood that pathogens will grow in the water distribution system. And, we would like to accomplish all of these health and safety functions in the most cost effective and sustainable manner possible.

At present, we believe that there are a few provisions in the IPC that inadvertently create a public health risk. Changing the temperature limits in this definition is one part of resolving this problem.

When the provisions in the current definitions and the related sections were first codified, Legionella was not a significant concern to public health; many items known today were unknown then. Now Legionella in building water systems has become a major concern for public health with the incidence of Legionnaires' disease growing by 500% from 0.4 cases per 100,000 people in 2000 to 2.0 cases per 100,000 people in 2015.¹

At the time these same provisions were codified, it used be thought that warm water was necessary for effective hand cleaning to control the spread of germs (bacteria). Science has since proven that the temperature of the water used for handwashing does not impact the efficacy of removing bacteria at all.^{2, 3, 4} While each of these three papers are very clear the CDC sums it up best with "The temperature of the water does not appear to affect microbe removal; however, warmer water may cause more skin irritation and is more environmentally costly"⁴ The most important variables for removing bacteria from ones hands are scrubbing and the use of soap. Neither of these criteria is within the purview of a building code.

When scald prevention was discussed as part of codifying these same provisions, the unintended consequences of lower water temperature on waterborne pathogen growth was not known. Accordingly temperature of 140°F originally proposed for scald control in home hot water heaters was lowered to 130°F and finally a recommendation of 120°F was made because if 140°F was OK it was thought that adding a huge safety margin would only be better, we now know that huge safety margin had serious and significant unintended consequences. A temperature of 120°F is considered an abundantly safe scald limit. However, setting water heaters this low results in much of the hot water distribution system being at temperatures that ideal for growing pathogens.

Since 1998 OSHA guidelines have stated that hot water should be stored at 140F and delivered at a temperature greater than 120F. In 2009, the CDC published a study documenting scalding cases resulting in hospital visits by the elderly from 2001-2006. The elderly are the highest risk population for Legionnaires' disease and one of the highest risk for scalding. They found that more than 80% of the scalding cases were due to cooking activities in the kitchen. Less than 3% (220 out of 8,620 cases) were plumbing related.¹³

We believe that it is time to use our current knowledge of these interrelated elements to improve health and safety by revising the a few of the temperature related provisions in the 2018 IPC and the 2018 IRC-P

In both the IPC and the IRC, hot water is required to be supplied to plumbing fixtures and plumbing appliances intended for bathing, washing, or culinary purposes. The 2018 IPC and IRC-P have two different maximum temperature thresholds, which some say are for scald prevention. The temperature at public hand washing sinks (lavatories), is limited to 110°F. With the exception of bidets and emergency fixtures, which are also limited to 110°F, all other fixtures are limited to 120°F. Please see the table below.

Water Temperature Provisions in the 2018 IPC and IRC-P

Fixture	Maximum Temperature	Section
Bidet	110F (43C)	IPC 408.3 IRC P2721.2
Emergency showers and eyewash stations	110F (43C)	IPC 411.1*
Individual shower valve	120F (49C)	IPC 412.3 IRC P2708.4
Multiple (gang) showers	120F (49C)	IPC 412.4
Temperature-actuated, flow-reduction devices for individual fixture fittings	120F (49C)	IPC 412.7
Public lavatories	110F (43C)	IPC 419.5
Bath tub and whirlpool tub	120F (49C)	IPC 412.5 IRC 2713.3
Head shampoo sink faucet	120F (49C)	IPC 412.10
Footbaths and pedicure baths	120F (49C)	IPC 423.3

* The maximum temperature is not shown in this IPC section, but rather in the referenced standard. This standard also has a minimum acceptable temperature of 60F for emergency fixtures. This lower number might be useful guidance for jurisdictions with cold incoming water temperatures that want to raise the temperature of cold water for hand washing during the winter months where only cold water is supplied to public lavatory faucets.

Bidets, emergency showers and eyewash stations and public lavatories are required to have tempered water supplied through a water temperature limiting device that conforms to the appropriate ASSE, ANSI or CSA standard. The upper

limit of 110°F makes sense for bidets and emergency showers. It does not make sense for hand washing at public lavatories.

If 120°F is a safe temperature for showering, bathing, head shampooing, tubs, it is equally safe for hand washing at either public or private lavatory faucets. It does not make sense that the temperature is lower for hand washing than for tub bathing. If the water temperature rises quickly to an uncomfortably hot and unsafe number it is much easier to remove ones hands from the water coming out of the faucet than it is to get out of a bathtub or to get out of the way in a shower. There is no need to have a lower temperature supplied for hand washing than for showering or bathing. In fact this public lavatory temperature code is derived from ASHRAE 90.1 energy saving code, not safety.

In our research into this issue, we found that the 110°F temperature limitation for hand washing at public lavatories comes from an energy code, ASHRAE 90.1 (1989)⁵ “Energy Standard for Buildings Except Low-Rise Residential Buildings.” Section 11.4.5.2 presents the provisions for lavatories in public facility restrooms (such as those in service stations, airports, train terminals, and convention halls). These include the requirement for low flow rates (the document preceded the 1990’s era EPACT rules concerning public lavatory faucet flow rates) and for limiting the temperature to a maximum of 110°F.

In the very high use public toilets detailed in 90.1 (1989) the sinks are used many times per hour, and the combination of low temperature and low flow does not dramatically increase the health risks from waterborne pathogens; the very high turnover rates of the water in the piping brings in new disinfectant.

However, many toilet facilities currently classified as “public” are only used sporadically. The combination of low hot water temperature, low flow rate and infrequent usage, results in a very low turnover rate which in turn means that new disinfectant enters the piping very infrequently. This condition not only provides a localized incubation chamber for Legionella but once grown can result in contaminating the rest of the hot water system.

While the idea of establishing 85-110°F as a safe range for public hand washing seemed like a good idea at the time, it turns out this range is ideal for the growth of pathogens in the building’s water distribution system. Pathogens that affect humans grow in temperatures that are found in our bodies: 85-110°F. For example, Legionella reproduces at the highest rates in the range of 85-110°F. Legionnaires’ disease, caused by Legionella growth in building water systems has become a major public health concern.

Adding to the risk due to temperature is the complexity of the internal components of the mixing valves and the lack of maintenance these valves typically receive. Such maintenance is relatively time consuming and costly and is often ignored. By way of comparison, Australian codes for health and safety purposes require these local mixing valves to be disassembled and disinfected annually^{6, 7, 8}

Conclusions and Recommendations:

If 120°F is safe enough to protect against scalding for bathing, it is safe enough for public hand washing. If this temperature is safe enough for Health Care Occupancies (IPC Section 609.3), it is safe enough for the other occupancies covered by the IPC.

Maintaining temperatures in the range of 85-110°F that is currently required in Section 419.5 is unsafe because it provides ideal conditions for the growth of pathogens, bacteria dangerous to humans. All Legionella guidelines including OSHA 1998⁹, ASHRAE 2000¹⁰, CDC 2003¹¹, and CDC 2016¹² recommend maintaining hot water temperatures at fixtures and in hot water return lines at or above 120°F.

It is not necessary to specify the temperature range for supplying water for hand washing in public lavatories, only the maximum temperature to prevent scalding.

We recommend that the maximum safe temperature for the discharge of hot water into public hand washing sinks be raised to 120°F.

We recommend moving the break point between tempered and hot water from 110°F to 120°F.

We recommend enabling the use of cold water only, or tempered water, or both at public hand washing sinks.

Bibliography:

1) Plumbing Supply Fittings, ASME A112.18.1-2005

2) Plumbing Supply Fittings, ASME A112.18.1-2012/CSA B125.1-12, page 5

3) ANSI/ASHRAE/IES Standard 90.1-2016, page 28,

4) US Centers for Disease Control (CDC) Atlanta, GA Chart titled, “Legionnaires’ Disease is on the Rise 2000-2015*” National Notifiable Diseases Surveillance System
<https://www.cdc.gov/legionella/downloads/fs-legionella-clinicians.pdf>

5) Quantifying the Effects of Water Temperature, Soap Volume, Lather Time, and Antimicrobial Soap as Variables in the Removal of Escherichia coli ATCC 11229 from Hands Journal of Food Protection June 2017 Dane A. Jensen,¹ David R. Macinga,² David J. Shumaker,² Roberto Bellino,² James W. Arbogast,² and Donald W. Schaffner¹
<http://jfoodprotection.com/doi/full/10.4315/0362-028X.JFP-16-370?code=fopr-site>

Above was in an article titled Cool Water as Effective as Hot for Removing Germs During Handwashing Infection Control Today May 30 2017

- 6) The environmental cost of misinformation: why the recommendation to use elevated temperatures for handwashing is problematic
International Journal of Consumer Studies Volume 37, Issue 4 July 2013 Amanda R. Carrico, Micajah Spoden, Kenneth A. Wallston, Michael P. Vandenberg
<http://onlinelibrary.wiley.com/doi/10.1111/ijcs.12012/abstract>
- 7) Show Me the Science - How to Wash Your Hands CDC Website
<https://www.cdc.gov/handwashing/show-me-the-science-handwashing.html>
- 8) ASHRAE 90.1 (1989) "Energy Standard for Buildings Except Low-Rise Residential Buildings"
- 9) Guidelines for the Control of Legionella in Manufactured Water Systems in South Australia, 2008 revised 2013
<http://www.sahealth.sa.gov.au/wps/wcm/connect/d2f047804755f77e91f5d322c3ec38c5/LegionellaGuidelines+revised+2013.pdf?MOD=AJPERES>
- 10) Department of Health & Human Services Victoria Australia Sept 2011 "Risk management plan for Legionella Control in health and aged care facilities"
<https://www2.health.vic.gov.au/about/publications/policiesandguidelines/risk-management-plan-for-legionella-control-in-health-and-aged-care-facilities>
- 11) Australian Standard. Water supply. Valves for the control of heated water supply temperatures Part 3: Requirements for field-testing, maintenance or replacement of thermostatic mixing valves, tempering valves and end-of-line temperature control devices
<https://www.saiglobal.com/PDFTemp/Previews/OSH/as/as4000/4000/40323.pdf>
- 12) Occupational Safety and Health Administration (OSHA) "Technical Manual Section III: Chapter 7 Legionnaires' Disease" 1998
https://www.osha.gov/dts/osta/otm/otm_iii/otm_iii_7.html
- 13) American Society of Heating, Refrigeration and Air-Conditioning Engineers, Inc. (ASHRAE) Guideline 12 "Minimizing the Risk of Legionellosis Associated with Building Water Systems" 2000
- 14) Centers for Disease Control and Prevention (CDC) Guidelines for Environmental Infection Control in Health-Care Facilities 2003
<https://www.cdc.gov/infectioncontrol/pdf/guidelines/environmental-guidelines.pdf>
- 15) Centers for Disease Control and Prevention (CDC) Developing a Water Management Program to Reduce Legionella Growth & Spread in Buildings
<https://www.cdc.gov/legionella/downloads/toolkit.pdf>

Cost Impact

The code change proposal will decrease the cost of construction .

Justification:

Limiting public restrooms to only those that have unrestricted access to the transient public will decrease the cost of construction. Only public restrooms are currently required to be supplied with tempered water. This requires the installation of a mixing valve that complies with ASSE 1070/ASME A112.1070/CSA B125.70 or CSA B125.3. These valves are relatively expensive. In addition these valves need regular service, which is also costly. Reducing the number of restrooms that are classified as public will reduce the number of such valves that are required to be installed.

Internal ID: 2284

P3-18

IPC: 202

Proponent: James Kendzel, representing American Supply Association (jkendzel@asa.net)

2018 International Plumbing Code

Revise as follows:

WATER DISPENSER. A plumbing fixture that is manually controlled by the user for the purpose of dispensing potable drinking water into a receptacle such as a cup, glass or bottle. Such fixture is connected to the potable water distribution system of the premises. ~~This definition includes a freestanding apparatus for the same purpose that is not connected to the potable water distribution system and that is supplied with potable water from a container, bottle or reservoir.~~

Reason:

The definition for water dispenser is being revised as it creates potential confusion and makes the provisions in Section 410.4 unenforceable. The definition of plumbing fixture is, a receptacle or device that is **connected to a water supply system** [emphasis added] or discharges to a drainage system or both. Such receptacles or devices require a supply of water; or discharge liquid waste or liquid-borne solid waste; or require a supply of water and discharge waste to a drainage system.

By definition, a water dispenser can not be both a plumbing fixture and a free standing device not connected to a potable water distribution system.

In addition, the general scope of the IPC is specifically related to the "the erection, installation, alteration, repairs, relocation, replacement, addition to, use or maintenance of **plumbing systems...**" [emphasis added]. A free standing device does not appear to be covered under the definition of **plumbing system** and therefore does not appear to fall within the scope of the IPC. Although a free standing device may fall under other regulations or agencies within a given jurisdiction, they do not appear to fall under the IPC.

Cost Impact

The code change proposal will not increase or decrease the cost of construction .

There should be no increase to construction since the proposed revision is only intended to provide consistency in the definition of terms and the use of those terms in the code.

Internal ID: 847

P4-18

202

Proponent: Jenifer Gilliland, City of Seattle, Washington, representing City of Seattle, Washington (jenifer.gilliland@seattle.gov)

2018 International Plumbing Code

SECTION 202 GENERAL DEFINITIONS

WATER COOLER. A drinking fountain that incorporates a means of reducing the temperature of the water supplied to it from the potable water distribution system.

Revise as follows:

WATER DISPENSER. A plumbing fixture that is manually controlled by the user for the purpose of dispensing potable drinking water into a receptacle such as a cup, glass or bottle. Such fixture is connected to the potable water distribution system of the premises. ~~This definition includes a freestanding apparatus for the same purpose that is not connected to the potable water distribution system and that is supplied with potable water from a container, bottle or reservoir.~~

SECTION 410 DRINKING FOUNTAINS

410.4 Substitution. Where restaurants provide drinking water in a container free of charge, drinking fountains shall not be required in those restaurants. In other occupancies where drinking fountains are required, *water dispensers* shall be permitted to be substituted for not more than 50 percent of the required number of drinking fountains.

Reason:

A freestanding apparatus should not be substituted for a drinking fountain. There is nothing to stop a building owner from discontinuing the service or removing the equipment.

Having access to drinking fountains where someone can get water or access to a water dispenser where someone can use their own cup or bottle is important for occupant's health as well as helping our environment by reducing the number of plastic bottles going into the landfill. By eliminating the option to substitute a non-plumbed free standing apparatus containing a reservoir for a drinking fountain, we will also be saving the energy it would have taken to deliver the jugs or containers of water to supply the apparatus.

The water dispenser, which in many installations would be a water bottle filling station, could be plumbed as a separate fixture, combined with the traditional high-low drinking fountain in new equipment, or attached after-the-fact to existing drinking fountains.

Cost Impact

The code change proposal will not increase or decrease the cost of construction .

Where this option is chosen, a permanent fixture would need to be installed instead of allowing for a portable system. However, there are a variety of options to choose from so the cost to the building owner should be about the same.

Internal ID: 3408

P5-18

IPC: 308.2

Proponent: Kelly Cobeen, Wiss Janney Elstner Associates, Inc., representing Federal Emergency Management Agency/ Applied Technology Council Seismic Code Support Committee (KCobeen@wje.com); Michael Mahoney, Federal Emergency Management Agency, representing Federal Emergency Management Agency (mike.mahoney@fema.dhs.gov)

2018 International Plumbing Code

Revise as follows:

308.2 Piping seismic supports. Where earthquake loads are applicable in accordance with the building code, plumbing piping supports, anchorage, and bracing shall be designed and installed for ~~the~~ seismic forces in accordance with Chapter 16 of the International Building Code.

Reason:

The added text clarifies the IBC location where specific seismic requirements are defined. This is simply intended to make the seismic design provisions more easily used, consistent with the intent as stated in 2015 NEHRP Recommended Provisions Section 1.1.2, to preserve life safety by maintaining the position of components through anchorage, bracing and strength.

Bibliography:

NEHRP Recommended Seismic Provisions for New Buildings and Other Structures, 2015 Edition (FEMA P-1050-1).

Cost Impact

The code change proposal will not increase or decrease the cost of construction .

The proposed wording clarifies the intent of the code and does not impose any new requirements that were not already in effect.

Internal ID: 1033

P6-18

IPC: TABLE 308.5

Proponent: Forest Hampton, Lubrizol Advanced Materials, Inc., representing Lubrizol Advanced Materials, Inc.
(forest.hampton@lubrizol.com)

2018 International Plumbing Code

Revise as follows:

**TABLE 308.5
HANGER SPACING**

PIPING MATERIAL	MAXIMUM HORIZONTAL SPACING (feet)	MAXIMUM VERTICAL SPACING (feet)
Acrylonitrile butadiene styrene (ABS) pipe	4	10 ^b
Aluminum tubing	10	15
Brass pipe	10	10
Cast-iron pipe	5 ^a	15
Chlorinated polyvinyl chloride (CPVC) pipe and tubing, 1 inch and smaller	3 ^c	10 ^b
Chlorinated polyvinyl chloride (CPVC) pipe and tubing, 1 ¹ / ₄ inches and larger	4 ^c	10 ^b
Copper or copper-alloy pipe	12	10
Copper or copper-alloy tubing, 1 ¹ / ₄ -inch diameter and smaller	6	10
Copper or copper-alloy tubing, 1 ¹ / ₂ -inch diameter and larger	10	10
Cross-linked polyethylene (PEX) pipe 1 inch and smaller	2.67 (32 inches)	10 ^b
Cross-linked polyethylene (PEX) pipe 1 ¹ / ₄ inch and larger	4	10 ^b
Cross-linked polyethylene/aluminum/cross-linked polyethylene (PEX-AL-PEX) pipe	2.67 (32 inches)	4
Lead pipe	Continuous	4
Polyethylene/aluminum/polyethylene (PE-AL-PE) pipe	2.67 (32 inches)	4
Polyethylene of raised temperature (PE-RT) pipe 1 inch and smaller	2.67 (32 inches)	10 ^b
Polyethylene of raised temperature (PE-RT) pipe 1 ¹ / ₄ inch and larger	4	10 ^b
Polypropylene (PP) pipe or tubing 1 inch and smaller	2.67 (32 inches)	10 ^b
Polypropylene (PP) pipe or tubing, 1 ¹ / ₄ inches and larger	4	10 ^b
Polyvinyl chloride (PVC) pipe	4	10 ^b
Stainless steel drainage systems	10	10 ^b
Steel pipe	12	15

For SI: 1 inch = 25.4 mm, 1 foot = 304.8 mm.

- a. The maximum horizontal spacing of cast-iron pipe hangers shall be increased to 10 feet where 10-foot lengths of pipe are installed.
- b. For sizes 2 inches and smaller, a guide shall be installed midway between required vertical supports. Such guides shall prevent pipe movement in a direction perpendicular to the axis of the pipe.
- c. For applications with lower use temperatures, piping support spacing shall be permitted to be in accordance with the manufacturer's installation instructions provided that such support spacing is approved.

Reason:

CPVC piping can use longer support spacing at lower temperatures, but additional tables would add complexity. Allowing a CPVC system to utilize specific manufacturer's instructions under specific conditions and with prior AHJ approval would be of use in some installations. A footnote seems sufficient in those cases.

Cost Impact

The code change proposal will not increase or decrease the cost of construction .

This will not increase the cost of construction as it only adds an additional option for the installer.

Internal ID: 1216

P7-18 Part I

Part I IPC: 308.3

Part II IRC: P2605.1

Proponent: Brian Helms, Charlotte Pipe and Foundry, Plastics Division, representing Charlotte Pipe and Foundry (brian.helms@charlottepipe.com)

THIS IS A 2 PART CODE CHANGE PROPOSAL. PART I WILL BE HEARD BY THE IPC COMMITTEE. PART II WILL BE HEARD BY THE IRC-PLUMBING COMMITTEE. SEE THE TENTATIVE HEARING ORDERS FOR THESE COMMITTEES.

2018 International Plumbing Code

Revise as follows:

308.3 Materials. Hangers, anchors and supports shall support the piping and the contents of the piping. Hangers and strapping material shall be of *approved* material that will not promote galvanic action. Hangers, anchors and supports shall be chemically compatible with the piping system.

Internal ID: 1741

P7-18 Part II

IRC: P2605.1

Proponent: Brian Helms, Charlotte Pipe and Foundry, Plastics Division, representing Charlotte Pipe and Foundry (brian.helms@charlottepipe.com)

2018 International Residential Code

Revise as follows:

P2605.1 General. Piping shall be supported in accordance with the following:

1. Piping shall be supported to ensure alignment and prevent sagging, and allow movement associated with the expansion and contraction of the piping system.
2. Piping in the ground shall be laid on a firm bed for its entire length, except where support is otherwise provided.
3. Hangers and anchors shall be of sufficient strength to maintain their proportional share of the weight of pipe and contents and of sufficient width to prevent distortion to the pipe. Hangers and strapping shall be of *approved* material that will not promote galvanic action. Hangers, anchors and supports shall be chemically compatible with the piping system.
4. Where horizontal pipes 4 inches (102 mm) and larger convey drainage or waste, and where a pipe fitting changes the flow direction greater than 45 degrees (0.79 rad), rigid bracing or other rigid support arrangements shall be installed to resist movement of the upstream pipe in the direction of flow. A change of flow direction into a vertical pipe shall not require the upstream pipe to be braced.
5. Piping shall be supported at distances not to exceed those indicated in Table P2605.1.

Reason:

Some hangers and supports may be coated with vinyl, rubber or plastic materials. These materials may be chemically incompatible with some piping materials and their use could cause a failure of the piping system. Only hanger or support products determined to be chemically compatible with the piping systems being installed should be allowed to be used.

Cost Impact

The code change proposal will not increase or decrease the cost of construction .

This code change proposal will not increase or decrease the cost of construction because is is intended to clarify the existing requirements in regards to the compatibility of the products used.

Internal ID: 3495

P8-18 Part I

IPC: 305.8 (New)

Proponent: Brian Helms, Charlotte Pipe and Foundry, Plastics Division, representing Charlotte Pipe and Foundry (brian.helms@charlottepipe.com)

THIS IS A 2 PART CODE CHANGE PROPOSAL. PART I WILL BE HEARD BY THE IPC COMMITTEE. PART II WILL BE HEARD BY THE IRC-PLUMBING COMMITTEE. SEE THE TENTATIVE HEARING ORDERS FOR THESE COMMITTEES.

2018 International Plumbing Code

Add new text as follows:

305.8 Protection against UV exposure. Where installed in direct sunlight, ABS, PVC and CPVC piping systems shall be protected from exposure to ultraviolet radiation by an opaque tape wrap having a thickness of not less than 0.04 inch (1.02 mm) or by water-based latex paint.

Internal ID: 1747

P8-18 Part II

IRC: P2603.4 (New)

Proponent: Brian Helms, Charlotte Pipe and Foundry, Plastics Division, representing Charlotte Pipe and Foundry (brian.helms@charlottepipe.com)

2018 International Residential Code

Add new text as follows:

P2603.4 Protection against UV exposure. Where installed in direct sunlight, ABS, PVC and CPVC piping systems shall be protected from exposure to ultraviolet radiation by an opaque tape wrap having a thickness of not less than 0.04 inch (1.02 mm) or by water-based latex paint.

Reason:

ABS, PVC and CPVC can suffer adverse effects from exposure to sunlight. Exposure to sunlight can cause surface discoloration and loss of impact strength to these piping systems. UV radiation affects PVC, CPVC and ABS when energy from the sun causes excitation of the molecular bonds in the plastic. The resulting reaction occurs only on the exposed surface of the pipe and to the extremely shallow depths of .001 to .003 inches. The effect does not continue when exposure to sunlight is terminated. A two-year study was undertaken to quantify the effects of UV radiation on the properties of PVC pipe (See Uni-Bell's UNI-TR-5). The study found that exposure to UV radiation results in a change in the pipe's surface color and a reduction in impact strength.

The presence of a solid surface between the sun and the pipe prevents UV degradation. One of the most common forms of UV protection is painting the pipe and fittings with a water based latex paint which has proven to be chemically compatible with these materials.

Bibliography:

[The Effects of Ultraviolet Radiation Radiation on PVC Pipe] [UNI-TR-5]

https://www.uni-bell.org/application/files/6014/5956/5837/The_Effects_of_Ultraviolet_Radiation_on_PVC_Pipe_.pdf

Cost Impact

The code change proposal will increase the cost of construction .

The cost of construction will increase slightly in certain applications because paint or tape material and the labor to apply will add minimal cost.

Internal ID: 3493

P9-18

IPC: 308.9

Proponent: Michael Cudahy, Plastic Pipe and Fittings Association (PPFA), representing Plastic Pipe and Fittings Association (mikec@cmservices.com)

2018 International Plumbing Code

Revise as follows:

308.9 Parallel water distribution systems. Piping bundles for manifold systems shall be supported in accordance with Table 308.5. Support at changes in direction shall be in accordance with the manufacturer's instructions. Where hot water piping is bundled with cold or hot water piping, ~~each-hot water pipe-piping~~ shall be insulated in accordance with Section 607.5.

Reason:

Energy code has specific insulation requirements for all piping, this proposal points to the correct section of the code. Maybe, these requirements should be moved or duplicated in the IPC.

Cost Impact

The code change proposal will not increase or decrease the cost of construction .

Requirements are already existing. The proposal points to the requirements.

Internal ID: 946

P10-18

IPC: 202, 310, 310.1, 310.3, TABLE 403.1 (IBC [P]2902.1), 403.3.2 (IBC [P]2902.3.2), 403.3.6 (IBC [P]2902.3.6), 405.3.2, 405.3.4, 405.3.5

Proponent: James Richardson Jr, representing City of Columbus Ohio (jarichardson@columbus.gov); Robert Schutz, representing City of Columbus, OH (RJSchutz@columbus.gov)

2018 International Plumbing Code

Revise as follows:

PRIVATE. In the classification of plumbing fixtures, “private” applies to fixtures in residences and apartments, and to fixtures in nonpublic toilet ~~rooms~~ facilities of hotels and motels and similar installations in buildings where the plumbing fixtures are intended for utilization by a family or an individual.

PUBLIC OR PUBLIC UTILIZATION. In the classification of plumbing fixtures, “public” applies to fixtures in general toilet ~~rooms~~ facilities of schools, gymnasiums, hotels, airports, bus and railroad stations, public buildings, bars, public comfort stations, office buildings, stadiums, stores, restaurants and other installations where a number of fixtures are installed so that their utilization is similarly unrestricted.

SECTION 310 WASHROOM AND TOILET ~~ROOM~~ FACILITY REQUIREMENTS

310.1 Light and ventilation. Washrooms and toilet ~~rooms~~ facilities shall be illuminated and ventilated in accordance with the International Building Code and International Mechanical Code.

310.3 Interior finish. Interior finish surfaces of toilet ~~rooms~~ facilities shall comply with the International Building Code.

**TABLE 403.1
MINIMUM NUMBER OF REQUIRED PLUMBING FIXTURES^a (See Sections 403.1.1 and 403.2)**

NO.	CLASSIFICATION	DESCRIPTION	WATER CLOSETS (URINALS: SEE SECTION 424.2)		LAVATORIES		BATHTUBS/ SHOWERS	DRINKING FOUNTAIN (SEE SECTION 410)	OTHER
			MALE	FEMALE	MALE	FEMALE			
1	Assembly	Theaters and other buildings for the performing arts and motion pictures ^d	1 per 125	1 per 65	1 per 200		—	1 per 500	1 service sink
		Night clubs, bars, taverns, dance halls and buildings for similar purposes ^d	1 per 40	1 per 40	1 per 75		—	1 per 500	1 service sink
		Restaurants, banquet halls and food courts ^d	1 per 75	1 per 75	1 per 200		—	1 per 500	1 service sink
		Gaming areas	1 per 100 for the first 400 and 1 per 250 for the remainder exceeding 400	1 per 50 for the first 400 and 1 per 150 for the remainder exceeding 400	1 per 250 for the first 750 and 1 per 500 for the remainder exceeding 750		—	1 per 1,000	1 service sink
		Auditoriums without permanent seating, art galleries, exhibition halls, museums, lecture halls, libraries, arcades and gymnasiums ^d	1 per 125	1 per 65	1 per 200		—	1 per 500	1 service sink
		Passenger terminals and transportation facilities ^d	1 per 500	1 per 500	1 per 750		—	1 per 1,000	1 service sink
		Places of worship and other religious services ^d	1 per 150	1 per 75	1 per 200		—	1 per 1,000	1 service sink
		Coliseums, arenas, skating rinks, pools and tennis courts for indoor sporting events and activities	1 per 75 for the first 1,500 and 1 per 120 for the remainder exceeding 1,500	1 per 40 for the first 1,520 and 1 per 60 for the remainder exceeding 1,520	1 per 200	1 per 150	—	1 per 1,000	1 service sink
Stadiums, amusement parks, bleachers and grandstands for outdoor sporting events and activities ^f	1 per 75 for the first 1,500 and 1 per 120 for the remainder exceeding 1,500	1 per 40 for the first 1,520 and 1 per 60 for the remainder exceeding 1,520	1 per 200	1 per 150	—	1 per 1,000	1 service sink		
2	Business	Buildings for the transaction of business, professional services, other services involving merchandise, office buildings, banks, light industrial and similar uses	1 per 25 for the first 50 and 1 per 50 for the remainder exceeding 50		1 per 40 for the first 80 and 1 per 80 for the remainder exceeding 80		—	1 per 100	1 service sink ^e
3	Educational	Educational facilities	1 per 50		1 per 50		—	1 per 100	1 service sink
4	Factory and industrial	Structures in which occupants are	1 per 100		1 per 100		—	1 per 400	1 service sink

		engaged in work fabricating, assembly or processing of products or materials					
5	Institutional	Custodial care facilities	1 per 10	1 per 10	1 per 8	1 per 100	1 service sink
		Medical care recipients in hospitals and nursing homes	1 per room ^c	1 per room ^c	1 per 15	1 per 100	1 service sink per floor
		Employees in hospitals and nursing homes ^b	1 per 25	1 per 35	—	1 per 100	—
		Visitors in hospitals and nursing homes	1 per 75	1 per 100	—	1 per 500	—
		Prisons ^b	1 per cell	1 per cell	1 per 15	1 per 100	1 service sink
		Reformatories, detention centers, and correctional centers ^b	1 per 15	1 per 15	1 per 15	1 per 100	1 service sink
		Employees in reformatories, detention centers and correctional centers ^b	1 per 25	1 per 35	—	1 per 100	—
		Adult day care and child day care	1 per 15	1 per 15	1	1 per 100	1 service sink
6	Mercantile	Retail stores, service stations, shops, sales rooms, markets and shopping centers	1 per 500	1 per 750	—	1 per 1,000	1 service sink ^e
7	Residential	Hotels, motels, boarding houses (transient)	1 per sleeping unit	1 per sleeping unit	1 per sleeping unit	—	1 service sink
		Dormitories, fraternities, sororities and boarding houses (not transient)	1 per 10	1 per 10	1 per 8	1 per 100	1 service sink
		Apartment house	1 per dwelling unit	1 per dwelling unit	1 per dwelling unit	—	1 kitchen sink per dwelling unit; 1 automatic clothes washer connection per 20 dwelling units
		Congregate living facilities with 16 or fewer persons	1 per 10	1 per 10	1 per 8	1 per 100	1 service sink
		One- and two-family dwellings and lodging houses with five or fewer guestrooms	1 per dwelling unit	1 per dwelling unit	1 per dwelling unit	—	1 kitchen sink per dwelling unit; 1 automatic clothes washer connection per dwelling unit
		Congregate living facilities with 16 or fewer persons	1 per 10	1 per 10	1 per 8	1 per 100	1 service sink
8	Storage	Structures for the storage of goods, warehouses, storehouse	1 per 100	1 per 100	—	1 per 1,000	1 service sink

	and freight depots. Low and Moderate Hazard.						
--	---	--	--	--	--	--	--

a.The fixtures shown are based on one fixture being the minimum required for the number of persons indicated or any fraction of the number of persons indicated. The number of occupants shall be determined by the International Building Code.

b.Toilet facilities for employees shall be separate from facilities for inmates or care recipients.

c.A single-occupant toilet ~~room-facility~~ with one water closet and one lavatory serving not more than two adjacent patient sleeping units shall be permitted provided that each patient sleeping unit has direct access to the toilet ~~room-facility~~ and provision for privacy for the toilet ~~room-facility~~ user is provided.

d.The occupant load for seasonal outdoor seating and entertainment areas shall be included when determining the minimum number of facilities required.

e.For business and mercantile classifications with an occupant load of 15 or fewer, service sinks shall not be required.

f.The required number and type of plumbing fixtures for outdoor public swimming pools shall be in accordance with Section 609 of the International Swimming Pool and Spa Code.

403.3.2 Prohibited toilet ~~room-facility~~ location. Toilet ~~rooms-facilities~~ shall not open directly into a room used for the preparation of food for service to the public.

403.3.6 Door locking. Where a toilet ~~room-facility~~ is provided for the use of multiple occupants, the egress door for the room shall not be lockable from the inside of the room. This section does not apply to family or assisted-use toilet ~~rooms-facilities~~.

405.3.2 Public lavatories. In employee and *public* toilet ~~rooms-facilities~~, the required lavatory shall be located in the same room as the required water closet.

405.3.4 Water closet compartment. Each water closet utilized by the *public* or employees shall occupy a separate compartment with walls or partitions and a door enclosing the fixtures to ensure privacy.

Exceptions:

1. Water closet compartments shall not be required in a single-occupant toilet room with a lockable door.
2. Toilet ~~rooms-facilities~~ located in a child day care ~~facilities~~ and containing two or more water closets shall be permitted to have one water closet without an enclosing compartment.
3. This provision is not applicable to toilet areas located within Group I-3 housing areas.

405.3.5 Urinal partitions. Each urinal utilized by the *public* or employees shall occupy a separate area with walls or partitions to provide privacy. The horizontal dimension between walls or partitions at each urinal shall be not less than 30 inches (762 mm). The walls or partitions shall begin at a height not greater than 12 inches (305 mm) from and extend not less than 60 inches (1524 mm) above the finished floor surface. The walls or partitions shall extend from the wall surface at each side of the urinal not less than 18 inches (457 mm) or to a point not less than 6 inches (152 mm) beyond the outermost front lip of the urinal measured from the finished backwall surface, whichever is greater.

Exceptions:

1. Urinal partitions shall not be required in a singleoccupant or family/assisted-use toilet room with a lockable door.
2. Toilet ~~rooms-facilities~~ located in a child day care ~~facilities~~ and containing two or more urinals shall be permitted to have one urinal without partitions.

Reason:

When toilet room was changed to toilet facility there were several instances in the code where the language wasn't changed. This proposal is just to clean up the language.

Cost Impact

The code change proposal will not increase or decrease the cost of construction .

This is just a cleanup for coordination of terminology that has no impact on costs.

Analysis: Duplicated text in the International Building Code is not shown for brevity.

P11-18 Part I

IPC: 312.3

Proponent: Robert Fuller, County of Roanoke, Virginia, representing R. G. Fuller (rfuller@roanokecountyva.gov)

THIS IS A 2 PART CODE CHANGE PROPOSAL. PART I WILL BE HEARD BY THE IPC COMMITTEE. PART II WILL BE HEARD BY THE IRC-PLUMBING COMMITTEE. SEE THE TENTATIVE HEARING ORDERS FOR THESE COMMITTEES.

2018 International Plumbing Code

Revise as follows:

312.3 Drainage and vent air test. Plastic piping shall not be tested using air except where air is removed by an evacuation of the system with a vacuum type pump to achieve a uniform gauge pressure of -5 psi (-34.5 kPa) or to balance a 10-inch column of mercury. An air test shall be made by forcing air into the system until there is a uniform gauge pressure of 5 psi (34.5 kPa) or sufficient to balance a 10-inch (254 mm) column of mercury. This pressure shall be held for a test period of not less than 15 minutes. Any adjustments to the test pressure required because of changes in ambient temperatures or the seating of gaskets shall be made prior to the beginning of the test period.

Internal ID: 1932

P11-18 Part II

IRC: P2503.5.1

Proponent: Robert Fuller, County of Roanoke, Virginia, representing R. G. Fuller (rfuller@roanokecountyva.gov)

2018 International Residential Code

Revise as follows:

P2503.5.1 Rough plumbing. DWV systems shall be tested on completion of the rough piping installation by water or, air for piping systems other than plastic or, by a vacuum of air for plastic piping systems, without evidence of leakage. ~~Either~~The test shall be applied to the drainage system in its entirety or in sections after rough-in piping has been installed, as follows:

1. Water test. Each section shall be filled with water to a point not less than 5 feet (1524 mm) above the highest fitting connection in that section, or to the highest point in the completed system. Water shall be held in the section under test for a period of 15 minutes. The system shall prove leak free by visual inspection.
2. Air test. The portion under test shall be maintained at a gauge pressure of 5 pounds per square inch (psi) (34 kPa) or 10 inches of mercury column (34 kPa). This pressure shall be held without introduction of additional air for a period of 15 minutes.
3. Vacuum Test. The portion under test shall be evacuated of air by a vacuum type pump to achieve a uniform gauge pressure of -5 pounds per square inch or a negative 10-inches of mercury column (-34 kPa). This pressure shall be held without the removal of additional air for a period of 15 minutes.

Reason:

The code change allowance for this alternate test is a means for testing plastic piping systems when the ambient temperatures are below freezing where water cannot be used for the test. There is no safety hazard in testing with a vacuum such as that has occurred in the past with a positive pressure test which is no longer allowed for just concern.

There is no requirement to use this alternate method.

The equipment to perform the test is readily available on the market and many contractors have this equipment to perform the test among their tools at present.

This allowance will actually help to mitigate the cost of construction delays and prevent potential damage to plastic piping systems when water cannot be used while avoiding the dangerous, now disallowed use of air pressurizing the plastic piping system.

Cost Impact

The code change proposal will decrease the cost of construction .

The code already requires testing. This alternate test method doesn't require any more time or materials than other testing methods. This is just an option that can be used.

The equipment to perform the test is readily available on the market and many contractors already have this equipment to perform the test among their tools at present. The cost of contractor tooling doesn't add to the cost of construction of the building as the contractor has to remain competitive.

However, use of this method will help to mitigate the cost of construction delays (waiting for warmer weather to test with water) and the cost of repairing freeze damage where testing with water is attempted in freezing weather.

Internal ID: 3432

P12-18

IPC: 312.10.2, Chapter 15

Proponent: Brianne Hall, representing Self (bnhall@ftch.com)

2018 International Plumbing Code

Revise as follows:

312.10.2 Testing. Reduced pressure principle, double check, pressure vacuum breaker, reduced pressure detector fire protection, double check detector fire protection, and spill-resistant vacuum breaker backflow preventer assemblies and hose connection backflow preventers shall be tested at the time of installation, immediately after repairs or relocation and at least annually. The testing procedure shall be performed in accordance with one of the following standards: ASSE 5013, ASSE 5015, ASSE 5020, ASSE 5047, ASSE 5048, ASSE 5052, ASSE 5056, CSA B64.10 or CSA B64.10.1. Test gauges shall comply with ASSE 1064.

Add new standard(s) follows:

ASSE

ASSE International
18927 Hickory Creek Drive, Suite
220
Mokena IL 60448

1064—2006 (R2011):

Performance Requirements for Backflow Prevention Assembly Field Test Kits

Reason:

Gauges that comply with ASSE 1064 are specifically designed for testing backflow devices describing the proper accuracy (linearity & repeatability) and precision, while compensating for varying operating conditions, EMI/FRI exposure, ambient temperatures, etc. Further, the gauges are required to be NIST-traceable, calibrated periodically, and are designed to be used in tandem with the current referenced standards in this section.

Cost Impact

The code change proposal will not increase or decrease the cost of construction .

No change to the cost of construction. Those that test backflow preventers may need to ensure that their gauge conforms with the standard.

Analysis: A review of the standard proposed for inclusion in the code, ASSE 1064-2006 (R2011), with regard to the ICC criteria for referenced standards (Section 3.6 of CP#28) will be posted on the ICC website on or before April 2, 2018.

Internal ID: 1772

P13-18

IPC: TABLE 403.1 (IBC: [P] TABLE 2902.1)

Proponent: Don Davies, Salt Lake City Corporation, representing Utah Chapter of International Code Council
(don.davies@slcgov.com)

2018 International Plumbing Code

Revise as follows:

**TABLE 403.1
MINIMUM NUMBER OF REQUIRED PLUMBING FIXTURES^a (See Sections 403.1.1 and 403.2)**

NO.	CLASSIFICATION	DESCRIPTION	WATER CLOSETS (URINALS: SEE SECTION 424.2)		LAVATORIES		BATHTUBS/ SHOWERS	DRINKING FOUNTAIN (SEE SECTION 410)	OTHER
			MALE	FEMALE	MALE	FEMALE			
1	Assembly	Theaters and other buildings for the performing arts and motion pictures ^d	1 per 125	1 per 65	1 per 200		—	1 per 500	1 service sink
		Nightclubs, bars, taverns, dance halls and buildings for similar purposes ^d	1 per 40	1 per 40	1 per 75		—	1 per 500	1 service sink
		Restaurants, banquet halls and food courts ^d	1 per 75	1 per 75	1 per 200		—	1 per 500	1 service sink
		Gaming areas	1 per 100 for the first 400 and 1 per 250 for the remainder exceeding 400	1 per 50 for the first 400 and 1 per 150 for the remainder exceeding 400	1 per 250 for the first 750 and 1 per 500 for the remainder exceeding 750		—	1 per 1,000	1 service sink
		Auditoriums without permanent seating, art galleries, exhibition halls, museums, lecture halls, libraries, arcades and gymnasiums ^d	1 per 125	1 per 65	1 per 200		—	1 per 500	1 service sink
		Passenger terminals and transportation facilities ^d	1 per 500	1 per 500	1 per 750		—	1 per 1,000	1 service sink
		Places of worship and other religious services ^d	1 per 150	1 per 75	1 per 200		—	1 per 1,000	1 service sink
		Coliseums, arenas, skating rinks, pools and tennis courts for indoor sporting events and activities	1 per 75 for the first 1,500 and 1 per 120 for the remainder exceeding 1,500	1 per 40 for the first 1,520 and 1 per 60 for the remainder exceeding 1,520	1 per 200	1 per 150	—	1 per 1,000	1 service sink
		Stadiums, amusement parks, bleachers and grandstands for outdoor sporting events and activities ^f	1 per 75 for the first 1,500 and 1 per 120 for the remainder exceeding 1,500	1 per 40 for the first 1,520 and 1 per 60 for the remainder exceeding 1,520	1 per 200	1 per 150	—	1 per 1,000	1 service sink
2	Business	Buildings for the transaction of business, professional services, other services involving merchandise, office buildings, banks, light industrial and similar uses	1 per 25 for the first 50 and 1 per 50 for the remainder exceeding 50		1 per 40 for the first 80 and 1 per 80 for the remainder exceeding 80		—	1 per 100	1 service sink ^e
3	Educational	Educational facilities	1 per 50		1 per 50		—	1 per 100	1 service sink
4	Factory and industrial	Structures in which occupants are engaged in work fabricating,	1 per 100		1 per 100		—	1 per 400	1 service sink

		assembly or processing of products or materials					
5	Institutional	Custodial care facilities	1 per 10	1 per 10	1 per 8	1 per 100	1 service sink
		Medical care recipients in hospitals and nursing homes	1 per room ^c	1 per room ^c	1 per 15	1 per 100	1 service sink per floor
		Employees in hospitals and nursing homes ^b	1 per 25	1 per 35	—	1 per 100	—
		Visitors in hospitals and nursing homes	1 per 75	1 per 100	—	1 per 500	—
		Prisons ^b	1 per cell	1 per cell	1 per 15	1 per 100	1 service sink
		Reformatories, detention centers, and correctional centers ^b	1 per 15	1 per 15	1 per 15	1 per 100	1 service sink
		Employees in reformatories, detention centers and correctional centers ^b	1 per 25	1 per 35	—	1 per 100	—
		Adult day care and child day care	1 per 15	1 per 15	1	1 per 100	1 service sink
6	Mercantile	Retail stores, service stations, shops, salesrooms, markets and shopping centers	1 per 500	1 per 750	—	1 per 1,000	1 service sink ^e
7	Residential	Hotels, motels, boarding houses (transient)	1 per sleeping unit	1 per sleeping unit	1 per sleeping unit	—	1 service sink
		<u>Hostels (transient)</u>	<u>1 per 10</u>	<u>1 per 10</u>	<u>1 per 8</u>	<u>1 per 100</u>	<u>1 service sink</u>
		Dormitories, fraternities, sororities and boarding houses (not transient)	1 per 10	1 per 10	1 per 8	1 per 100	1 service sink
		Apartment house	1 per dwelling unit	1 per dwelling unit	1 per dwelling unit	—	1 kitchen sink per dwelling unit; 1 automatic clothes washer connection per 20 dwelling units
		Congregate living facilities with 16 or fewer persons	1 per 10	1 per 10	1 per 8	1 per 100	1 service sink
		One- and two-family dwellings and lodging houses with five or fewer guestrooms	1 per dwelling unit	1 per dwelling unit	1 per dwelling unit	—	1 kitchen sink per dwelling unit; 1 automatic clothes washer connection per dwelling unit
7	Residential	Congregate living facilities with 16 or fewer persons	1 per 10	1 per 10	1 per 8	1 per 100	1 service sink
8	Storage	Structures for the storage of goods, warehouses, storehouse and freight	1 per 100	1 per 100	—	1 per 1,000	1 service sink

Reason:

Hostels are not addressed in the code and they are unique in that they operate like a hotel/motel for transient stay as an R-1 occupancy but the restrooms facilities provided resemble the requirements for R-2 boarding houses where restroom facilities are shared as opposed to hotels and motels where each sleep unit must be provided with its own water closet, lavatory and tub or shower. This creates a problem when applying the provisions of I.B.C. Table 2902.1. The resolution would be to create another R-1 occupancy designation with a description of Hostels and place the requirements for plumbing fixtures from R-2 boarding houses into that classification. A precedent has already been established with two R-2 classifications one for boarding houses and another for apartments which have different requirements. Arbitrarily placing hostels in an R-2 occupancy group would also subject that use to the more restrictive accessibility requirements of I.B.C. Section 1106.2.2.1. While hostels are not that common in the U.S. they are quite common elsewhere in the world and the I.B.C. is an international code so this issue should be addressed.

Cost Impact

The code change proposal will decrease the cost of construction .

As the code is written, the hostel would be required to be classified as an R-1 occupancy and would required to have restrooms in each sleeping room. With the proposed change, the hostel classification would still remain an R-1 occupancy but the number of restrooms would decrease.

Analysis: Duplicated text in the IBC is not shown for brevity.

Internal ID: 2116

P14-18

IPC: 403.1.1

Proponent: Josephine Ortega, representing University of California

2018 International Plumbing Code

Revise as follows:

403.1.1 Fixture calculations. To determine the occupant load of each sex, the total occupant load shall be divided in half. To determine the required number of fixtures, the fixture ratio or ratios for each fixture type shall be applied to the occupant load of each sex in accordance with Table 403.1. Fractional numbers resulting from applying the fixture ratios of Table 403.1 shall be rounded up to the next whole number. For calculations involving multiple *occupancies*, such fractional numbers for each *occupancy* shall first be summed and then rounded up to the next whole number.

~~Exception~~ Exceptions:

1. The total occupant load shall not be required to be divided in half where *approved* statistical data indicates a distribution of the sexes of other than 50 percent of each sex.
2. Where multi-user facilities are designed to serve all genders, the minimum fixture count shall be calculated 100%, based on total occupant load. In such multi-user user facilities, each fixture type shall be in accordance with ICC A117.1 and each urinal that is provided shall be located in a stall.

Reason:

This proposal will permit designers to design gender specific facilities using either the men or women category. The proposal will also bridge the gap of designing for facilities that elect to install all-inclusive bathroom/restrooms.

Bibliography:

Cost Impact

The code change proposal will not increase or decrease the cost of construction .

This proposal simply offers a different way to design toilet facilities. No fixtures are being added or subtracted therefore, there is no impact to the cost of construction.

Internal ID: 2348

P15-18

IPC: 403.1.1 (IBC [P] 2902.1.1), 403.1.2 (IBC [P] 2902.1.2), 403.2 (IBC [P] 2902.2)

Proponent: David Collins, representing The American Institute of Architects (dcollins@preview-group.com)

2018 International Plumbing Code

Revise as follows:

403.1.1 Fixture calculations. To determine the occupant load of each sex, the total occupant load shall be divided in half. To determine the required number of fixtures, the fixture ratio or ratios for each fixture type shall be applied to the occupant load of each sex in accordance with Table 403.1. Fractional numbers resulting from applying the fixture ratios of Table 403.1 shall be rounded up to the next whole number. For calculations involving multiple *occupancies*, such fractional numbers for each *occupancy* shall first be summed and then rounded up to the next whole number.

~~Exception~~ **Exceptions:**

1. The total occupant load shall not be required to be divided in half where *approved* statistical data indicates a distribution of the sexes of other than 50 percent of each sex.
2. Distribution of the sexes is not required where single-user water closets and bathing room fixtures are provided in accordance with Section 403.1.2.

403.1.2 Single-user toilet facility and bathing room fixtures. The plumbing fixtures located in single-user toilet ~~facilities~~ and bathing rooms, including family or assisted-use toilet and bathing rooms that are required by Section 1109.2.1 of the International Building Code, shall contribute toward the total number of required plumbing fixtures for a building or tenant space. Single-user toilet ~~facilities~~ and bathing rooms, and family or assisted-use toilet rooms and bathing rooms shall be identified for use by either sex.

The total number of fixtures shall be permitted to be based on the required number of separate facilities or based on the aggregate of any combination of single-user or separate facilities.

403.2 Separate facilities. Where plumbing fixtures are required, separate facilities shall be provided for each sex.

Exceptions:

1. Separate facilities shall not be required for dwelling units and sleeping units.
2. Separate facilities shall not be required in structures or tenant spaces with a total occupant load, including both employees and customers, of 15 or fewer.
3. Separate facilities shall not be required in mercantile *occupancies* in which the maximum occupant load is 100 or fewer.
4. Separate facilities shall not be required in business occupancies in which the maximum occupant load is 25 or fewer.
5. Separate facilities shall not be required to be designated by sex where single-user toilets rooms are provided in accordance with Section 403.1.2.
6. Separate facilities shall not be required where rooms having both water closets and lavatory fixtures are designed for use by both sexes and privacy for water closets are installed in accordance with Section 405.3.4.

Reason:

As part of the changes to the 2018 code provisions were added to allow single user toileting features to be counted toward the total number of fixtures required despite their designation by sex or family. This change is proposed to clarify how toilet rooms that are configured in such a manner to allow use by either sex can also be used. Many communities have been asking to use these provisions in advance of full adoption of the 2018 codes because of their need to address significant issues of gender and equality for access.

The codes only require the installation of family or assisted-use facilities in a limited number of occupancies. With this change the codes will allow the design of facilities that are available to those needing assistance by other assistants that are of an opposite gender without causing any discomfort by anyone.

Cost Impact

The code change proposal will decrease the cost of construction .

This change would reduce the cost of construction because the duplication of areas used for single sex facilities can

be eliminated saving unneeded floor area.

Analysis: Duplicated text in the International Building Code is not shown for brevity.

Internal ID: 1731

P16-18

IPC: 403.1.2 (IBC [P]2902.1.2)

Proponent: James P. Colgate, Esq., RA, CFM, Bryan Cave LLP, representing National Center for Transgender Equality (James.Colgate@bryancave.com); David Collins, representing The American Institute of Architects (dcollins@preview-group.com)

2018 International Plumbing Code

Revise as follows:

403.1.2 Single-user toilet facility and bathing room fixtures. The plumbing fixtures located in single-user toilet facilities and bathing rooms, including family or assisted-use toilet and bathing rooms that are required by Section 1109.2.1 of the International Building Code, shall contribute toward the total number of required plumbing fixtures for a building or tenant space. Single-user toilet facilities and bathing rooms, and family or assisted-use toilet rooms and bathing rooms shall be identified as being available for use by ~~either~~ all persons regardless of their sex.

Reason:

This proposal merely clarifies some of the ambiguous language in a previous change adopted by the Membership in the last code cycle. Pursuant to P40-15, Public Comment 2, Section 403.1.2 of the International Plumbing Code was revised to state that “toilet and bathroom facilities be identified for use by either sex.” The Membership’s stated reason for adopting Public Comment 2 was two-fold. First, the change allowed designers to adopt single-occupant toilet rooms, rather than grouped facilities. Second, and more importantly, the Membership adopted this change to alleviate some of the issues transgender individuals face.

Under the design scheme approved by P40-15, Public Comment 2, the same numbers of fixtures are provided, and waiting time is reduced by allowing either sex to use the toilet room. However, despite the Membership’s intention to alleviate some of the problems transgender people face, the adopted language “for use by either sex” remains vague and subject to competing interpretations. For example, a designer might interpret “identified for use by either sex” to mean that single-user, family, or assisted-use toilet facilities could be identified for use by men, or could be identified for use by women, but not necessarily be identified for use by both men and women.

In response to this ambiguity, the National Center for Transgender Equality urges the Committee to approve this code change proposal to clarify Section 403.1.2 of the International Plumbing Code by including language that bathroom identification be “available for use by all persons regardless of their sex.” This modification resolves the problem of ambiguous interpretations because it could not logically be construed that it is permissible for bathroom signage to exclude one gender over the other. In essence, this proposal more accurately reflects the Membership’s intention to permit certain facilities to be identified for use by any and all persons.

Cost Impact

The code change proposal will not increase or decrease the cost of construction .

This proposal has no cost impact. The Membership already adopted this proposal in the 2018 International Plumbing Code. Rather than impose additional design costs, this proposal merely seeks to make a clarification. This proposal would better reflect the Membership’s intention than the current code.

Analysis: Duplicated text in the International Building Code is not shown for brevity.

Internal ID: 1432

P17-18

IPC: 403.2 (IBC [P]2902.2)

Proponent: James P. Colgate, Esq., RA, CFM, Bryan Cave LLP, representing National Center for Transgender Equality (James.Colgate@bryancave.com); David Collins, representing The American Institute of Architects (dcollins@preview-group.com)

2018 International Plumbing Code

Revise as follows:

403.2 Separate facilities. Where plumbing fixtures are required, separate facilities shall be provided for each sex.

Exceptions:

1. Separate facilities shall not be required for dwelling units and sleeping units.
2. Separate facilities shall not be required in structures or tenant spaces with a total occupant load, including both employees and customers, of 15 or fewer.
3. Separate facilities shall not be required in mercantile *occupancies* in which the maximum occupant load is 100 or fewer.
4. Separate facilities shall not be required in business occupancies in which the maximum occupant load is 25 or fewer.
5. Separate facilities shall not be required where all water closet compartments are provided with partitions, including the doors thereto, that extend to the floor and to the ceiling.

Reason:

Colleges across the United States, private businesses, membership clubs, and many establishments throughout Europe have adopted an alternative design for bathroom and toilet facilities that removes the requirement that such facilities be designated for use by a specific sex. This design has proven to be useful, effective, and economical.

NCTE's proposal would give designers the option of group toilet rooms regardless of sex, as long as each stall has partitions on all four sides that extend to the floor. Partitions ensure that the user's privacy is maintained. This proposal is advantageous because the partitions remove the embarrassment that many people face in a shared restroom facility. Additionally, group toilet facilities promote shorter wait times for the restroom and waste less space on a general bathroom waiting area.

It should be noted that this proposal does not trigger compliance with Exception 3 of IBC Section 1109.2, which requires that 50% of single-user toilet or bathing rooms clustered in a single location be accessible. The water closet compartments in this proposal need not contain a lavatory, and thus do not constitute a "toilet room" as such term is used in IPC Section 405.3.4 and IBC Sections 1109.2.1.2, 1109.2.2, and 1109.2.3. Rather, such "water closet compartments" are subject to the 5% rule of IBC Section 1109.2.2.

It should be noted that this proposal does not trigger compliance with Exception 2 of Section 1109.2 of the International Building Code, which requires that 50% of single-user toilet or bathing rooms clustered in a single location be accessible. Section 1109.2.1.2 of the International Building Code defines "toilet room" to include a water closet and a lavatory. Under NCTE's proposed design scheme, the partitioned stalls need not contain sinks or wash basins, and would therefore be treated as ordinary toilet compartments and subject to the 5% rule of Section 1109.2.2 of the International Building Code.

Cost Impact

The code change proposal will not increase or decrease the cost of construction .

The same numbers of fixtures are still required and waiting time will be reduced by allowing any sex to use any available water closet compartment. Further, the general waiting area and space required for two facilities will not be necessary in places with this design option. While that may save a small cost, an additional cost may be expended to create partitions on all four sides that extend to the floor.

Analysis: Duplicated text in the International Building Code is not shown for brevity.

Internal ID: 1426

P18-18

IPC: 403.2

Proponent: Josephine Ortega, representing University of California

2018 International Plumbing Code

Revise as follows:

403.2 Separate facilities. Where plumbing fixtures are required, separate facilities shall be provided for each sex.

Exceptions:

1. Separate facilities shall not be required for dwelling units and sleeping units.
2. Separate facilities shall not be required in structures or tenant spaces with a total occupant load, including both employees and customers, of 15 or fewer.
3. Separate facilities shall not be required in mercantile *occupancies* in which the maximum occupant load is 100 or fewer.
4. Separate facilities shall not be required in business occupancies in which the maximum occupant load is 25 or fewer.
5. Where multi-user facilities are designed to serve all genders, the minimum fixture count shall be calculated 100% based on the total occupant load. In such facilities, each fixture type shall be in accordance with ICC A117.1. Urinals provided shall be located in a stall.

Reason:

This proposal will permit designers to design gender specific facilities using either the men or women category. The proposal will also bridge the gap of designing for facilities that elect to install all-inclusive bathroom/restrooms.

Cost Impact

The code change proposal will not increase or decrease the cost of construction .

This proposal simply offers a different way to design toilet facilities. No fixtures are being added or subtracted therefore, there is no impact to the cost of construction.

Internal ID: 2349

P19-18

IPC: 403.3.1 (IBC [P] 2902.3.1), 403.5 (IBC [P] 2902.5)

Proponent: Dawn Anderson, representing self (gonedawning@yahoo.com); Dan Buuck, representing National Association of Home Builders (dbuuck@nahb.org); David Collins, representing the American Institute of Architects (dcollins@preview-group.com); Marsha Mazz, representing U.S. Access Board (mazz@Access-Board.gov); Dominic Marinelli, representing United Spinal Association (DMarinelli@accessibility-services.com)

2018 International Plumbing Code

Revise as follows:

403.3.1 Access. The route to the *public* toilet facilities required by Section 403.3 shall not pass through kitchens, storage rooms or closets. Access to the required facilities shall be from within the building or from the exterior of the building. ~~Routes shall comply with the accessibility requirements of the International Building Code.~~ The public shall have access to the required toilet facilities at all times that the building is occupied.

403.5 Drinking fountain location. Drinking fountains shall not be required to be located in individual tenant spaces provided that *public* drinking fountains are located within a distance of travel of 500 feet (152 m) of the most remote location in the tenant space and not more than one story above or below the tenant space. Where the tenant space is in a covered or open mall, such distance shall not exceed 300 feet (91 m). ~~Drinking fountains shall be located on an accessible route.~~

Reason:

Accessibility is addressed in Section 404 of the IPC, which includes specifics for accessible routes connecting accessible elements - including exceptions to the vertical route between levels that may contain toilets or drinking fountains. The language is redundant in Section 403.3.1 and is not needed. The language in Section 403.5 is also not consistent with 403.3.1 and could be interpreted to prohibit any drinking fountains to be installed on floors without elevator service. This is not the intent of the accessibility provisions.

Cost Impact

The code change proposal will not increase or decrease the cost of construction .

The proposal will eliminate possible conflicts between the IPC and accessibility requirements. The change is only correlative and contains, in itself, no substantive changes.

Analysis: Duplicated text in the International Building Code not shown for brevity.

Internal ID: 548

P20-18 Part I

IPC: 403.3.3 (IBC [P] 2902.3.3)

Proponent: Brian Tollisen, Division of Building Standards & Codes, New York State Dept. of State, representing Division of Building Standards and Codes, New York State Department of State (Brian.Tollisen@dos.ny.gov)

BOTH PARTS OF THIS PROPOSAL WILL BE HEARD BY THE IPC-IPSDC COMMITTEE. SEE HEARING AGENDA FOR THE IPC-IPSDC COMMITTEE.

2018 International Plumbing Code

Revise as follows:

403.3.3 Location of toilet facilities in occupancies other than malls.. In occupancies other than covered and open mall buildings, the required *public* and employee toilet facilities shall be located not more than one story above or below the space required to be provided with toilet facilities, and the path of travel to such facilities shall not exceed a distance of 500 feet (152 m).

Exception: ~~The location and maximum distances of travel~~ The location(s) of required employee plumbing fixtures are allowed to be located in adjacent structures under the same ownership, lease or control. The maximum travel distance to required employee facilities in factory and industrial occupancies, storage buildings and kiosks are permitted to exceed that required by this section, provided that the location and maximum distance of travel are approved. travel distance is approved.

Analysis: Duplicated text in the IBC is not shown for brevity.

Internal ID: 1357

P20-18 Part II

IPMC: 503.3

Proponent: Brian Tollisen, Division of Building Standards & Codes, New York State Dept. of State, representing Division of Building Standards and Codes, New York State Department of State (Brian.Tollisen@dos.ny.gov)

2018 International Property Maintenance Code

Revise as follows:

[P] 503.3 Location of employee toilet facilities.. Toilet facilities shall have access from within the employees' working area. The required toilet facilities shall be located not more than one story above or below the employees' working area and the path of travel to such facilities shall not exceed a distance of 500 feet (152 m). Employee facilities shall either be separate facilities or combined employee and public facilities.

Exception: ~~Facilities that are required for employees in storage structures or kiosks, which are~~ The location(s) of required employee plumbing fixtures are allowed to be located in adjacent structures under the same ownership, lease or control, shall not exceed a travel distance of 500 feet (152 m) from the employees' regular working area to the facilities. ~~control. The maximum travel distance to required employee facilities in factory and industrial occupancies, storage buildings and kiosks are permitted to exceed that required by this section, provided the travel distance is approved.~~

Reason:

The code sections currently are not coordinated with regards to the locations of employee plumbing facilities. This proposal brings consistency between the IPC and IPMC for the locations of employee toilet facilities. The spaces listed in the exception; factory and industrial occupancies, storage buildings and kiosks, are traditionally not provided with plumbing facilities due to the proximity to available facilities and due to the nature of their use. This change should also remove unnecessary violations issued due to the discrepancy in the current code language.

Cost Impact

The code change proposal will decrease the cost of construction .

Construction costs will decrease for the applicable occupancies by not requiring plumbing fixtures when adjacent facilities are approved.

Internal ID: 3394

P21-18

IPC: 403.3.3 (IBC [P]2902.3.3)

Proponent: Andrew Klein, representing Self Storage Association (andrew@asklein.com)

2018 International Plumbing Code

Revise as follows:

403.3.3 Location of toilet facilities in occupancies other than malls. In occupancies other than covered and open mall buildings, the required *public* and employee toilet facilities shall be located not more than one story above or below the space required to be provided with toilet facilities, and the path of travel to such facilities shall not exceed a distance of 500 feet (152 m).

Exception-Exceptions:

1. The location and maximum distances of travel to required employee facilities in factory and industrial *occupancies* are permitted to exceed that required by this section, provided that the location and maximum distance of travel are *approved*.
2. The location and maximum distances of travel to required public and employee facilities in Group S occupancies are permitted to exceed that required by this section, provided that the location and maximum distance of travel are approved

Reason:

This proposal adds exception #2, which builds on the existing exception for employee toilet facilities in factory and other industrial occupancies when approved by the code official. Because these types of occupancies have extremely low occupancy rates, it is not a cost-effective use of space or resources to require the same number of independent restrooms when they will rarely be utilized. The new exception for Group S facilities recognizes that even though there may be members of the public present in some S occupancies, the overall use of the building is similar to that of an industrial facility, where occupancy rates and dwell times are extremely low.

This proposal provides the code official the authority to increase the number of floors between restrooms from every other floor to something more appropriate in parking garages with attendants, self storage facilities, and other similar Group S buildings with low occupancy rates and dwell times.

Cost Impact

The code change proposal will decrease the cost of construction .

This code change proposal has the potential to decrease the cost of construction if the code official approves a reduction in the number of toilet facilities.

Analysis: Duplicated text in the IBC is not shown for brevity.

Internal ID: 1674

P22-18 Part I

IBC: 1109.2.1.7

Proponent: Jason Phelps, representing Self (jason.phelps@hillsboro-oregon.gov)

THIS IS A TWO PART CODE CHANGE. BOTH PARTS OF THIS CODE CHANGE WILL BE HEARD BY THE PLUMBING CODE DEVELOPMENT COMMITTEE. SEE THE TENTATIVE HEARING ORDER FOR THIS COMMITTEE.

2018 International Building Code

Revise as follows:

1109.2.1.7 Privacy. Doors to family or assisted-use toilet and bathing rooms shall be securable from within the room and be provided with an "occupied" indicator.

Internal ID: 1436

P22-18 Part II

IPC: 403.3.7 (New); IBC: 2902.3.7 (New)

Proponent: Jason Phelps, representing Self (jason.phelps@hillsboro-oregon.gov)

2018 International Plumbing Code

Add new text as follows:

403.3.7 Privacy. Doors to single-user toilet and bathing rooms and family or assisted-use toilet and bathing rooms shall be securable from within the room and be provided with an "occupied" indicator.

2018 International Building Code

Add new text as follows:

2902.3.7 Privacy. Doors to single-user toilet and bathing rooms and family or assisted-use toilet and bathing rooms shall be securable from within the room and be provided with an "occupied" indicator.

Reason:

This code change proposal will alleviate privacy and safety concerns by requiring the occupied indicator for single user restrooms. Without an occupied indicator, the only way for someone to see if the room is in use is to turn the handle. This causes safety and privacy concerns for the user. This can cause severe discomfort, even fear, for children or people who have suffered trauma. This proposal will proactively provide increased comfort and safety for everyone.

It is the intent of this proposal to have the added coordinate section IBC 2902.3.7, later scoped by CCC as "[P]" as everything else in Chapter 29 is [P] scoped.

Cost Impact

The code change proposal will increase the cost of construction .

Adding the occupied indicator to the already required privacy lock increases the cost of the hardware by no more than a few dollars per door.

Internal ID: 3488

P23-18

IPC: 403.6 (New)

Proponent: Eirene Knott, BRR Architecture, representing Metropolitan Kansas City Chapter of the ICC
(Eirene.Knott@brrarch.com)

2018 International Plumbing Code

Add new text as follows:

403.6 Service sink location. Service sinks shall not be required to be located in individual tenant spaces in a covered mall provided that service sinks are located within a distance of travel of 300 feet (91 m) of the most remote location in the tenant space and not more than one story above or below the tenant space. Service sinks shall be located on an accessible route.

Reason:

There were at least two attempts in the 2015/2016/2017 code development cycle to reduce or remove the requirement of a service sink. One proposal was to not require a service sink where the occupant load was 30 or less. The committee felt that raising the occupant threshold and applying that load across the board would result with some occupancies not having a sink but would need the sink for other regulations such as health code requirements.

The other proposed code changes came from the PMG CAC adding a new section for service sinks allowing for a service sink to be located in a central core of a building. The committee disapproved that code change because it called for a minimum outlet drain of 3 inches in diameter. The committee felt the 3-inch requirement was overkill and felt the proposed code change also superseded the requirements of Table 403.1.

Despite attempts during the public comment phase where both proposal were approved, both were disapproved in the final action process. Based on the action at the public comment phase, there is an understanding that some small tenant spaces, especially those within a mall, do not need to have the service sink in a readily accessible location. Since both drinking fountains and public toilets are allowed to be within 300 feet of a tenant space in a mall, the same travel distance seems reasonable for access to a service sink. I have opted to have this change apply only to tenants within a covered mall as in some parts of the country it may not be practical for tenants in an outdoor mall to push a mop bucket 300 feet in the snow.

For a small tenant that may not meet footnote e to Table 403.1, the addition of a service sink can take up much needed tenant space, let alone add an additional cost that can negatively impact the tenant space overall. Most small tenants do not need a service sink but knowing that one would be available to them, just like a public restroom and drinking fountain are available within the same travel distances, would provide a sense of security.

Cost Impact

The code change proposal will decrease the cost of construction .

This may reduce the cost of construction as each individual tenant would not be required to provide a service sink, reducing the cost of materials needed.

Internal ID: 112

P24-18

IPC: 404.1, 404.2, 404.3

Proponent: Dawn Anderson, representing self (gonedawning@yahoo.com); Dan Buuck, representing National Association of Home Builders (dbuuck@nahb.org); David Collins, representing the American Institute of Architects (dcollins@preview-group.com); Marsha Mazz, representing U.S. Access Board (mazz@Access-Board.gov); Dominic Marinelli, representing United Spinal Association (DMarinelli@accessibility-services.com)

2018 International Plumbing Code

Revise as follows:

404.1 Where required. Accessible plumbing facilities and fixtures shall be provided in accordance with the International Building Code and ICC A117.1.

Delete without substitution:

~~**404.2 Accessible fixture requirements.** Accessible plumbing fixtures shall be installed with the clearances, heights, spacings and arrangements in accordance with ICC A117.1.~~

~~**404.3 Exposed pipes and surfaces.** Water supply and drain pipes under accessible lavatories and sinks shall be covered or otherwise configured to protect against contact. Pipe coverings shall comply with ASME A112.18.9.~~

Reason:

Section 404.2 and 404.3 were added by P42-12. They should be removed for multiple reasons. The reference to IBC would also get a reference to ICC A117.1 in Section 1101.2, however, if there is a concern that this may be missed by plumbing inspectors, the reference can be added in Section 404.1.

In Section 404.2, the laundry list is incomplete on what is required in the A117.1 for accessible plumbing fixtures. Since standards are only referenced to the extent the code sends you there (Section 102.8), this could be misinterpreted as intending to limit requirements that would be applicable in the standard. The requirement for pipe protection is a technical requirement for accessible lavatories, address in A117.1 Section 606.6, so it should not be repeated here. The ASME A112.18.9 standard addresses the requirements for heat transfer, not cold, therefore it only addresses half the issue associated with water, and not all the issues associated with accidental contact. The test for hot water is substantially hotter than tempered water which is required for public lavatories. Also, if the pipes are protected from contact by some type of shield as indicated in the photo, there is no exception for compliance with the standard, even if there is no contact with the pipes. If ASME A112.18.9 should be referenced, this standard should be reviewed through the ICC A117.1 process for technical issues associated with accessibility requirements. It does not belong in the IPC.



Cost Impact

The code change proposal will not increase or decrease the cost of construction .

The proposal is only clarification that will eliminate potential conflicts between the IPC and ICC A117.1.

Internal ID: 546

P25-18

IPC: 404.3, Chapter 15

Proponent: Howard Ahern, representing Plumberex Speciality Products

2018 International Plumbing Code

Revise as follows:

404.3 Exposed pipes and surfaces. Water supply and drain pipes under accessible lavatories and sinks shall be covered or otherwise configured to protect against contact. Pipe coverings shall comply with ASME A112.18.9 or ASTM C1822.

Add new standard(s) follows:

ASTM

ASTM International
100 Barr Harbor Drive, P.O. Box
C700
West Conshohocken PA 19428-
2959
US

C1822-2015:

Standard Specification for Insulating Covers on Accessible Lavatory Piping

Reason:

There is a new standard that has been developed specifically for insulating covers over water supply pipes and drain piping under accessible lavatories. The new standard is titled: ASTM C1822-2015 Standard Specification for Insulating covers on Accessible Lavatory Piping. The Standard was developed by the C16.40 Thermal Insulation Systems committee. The new standard covers all of ASME A112.18.9 requirements but is a more comprehensive standard than ASME A112.18.9 and has additional language covering requirements related to restrictions on cable tie fasteners associated with a Federal lawsuit.

This code modification allows both the ASME A112 18.9 standard and would also allow ASTM C1822 compliance. designers are able to comply with either standard . Both standards are needed for these products allowing compliance with either standard will help contractors and inspectors with compliance and identification, while also allowing greater compliance with Department of Justice 2010 Americans with Disability Act standard for Assessable Design Standard 606.5 and ANSI Standard A117.1.

Bibliography:

Howard Ahern representing Plumberex Speciality Products.

Member ASME A112. 18.9 standard

Chairman ASTM C1822 Standard Committee

Cost Impact

The code change proposal will not increase or decrease the cost of construction .

No cost increase would be associated with this modification as there are many under sink Insulation products sold nationwide which already complying with this standard that are of no increased cost to the industry.

Analysis: A review of the standard proposed for inclusion in the code, ASTM C1822-2015, with regard to the ICC criteria for referenced standards (Section 3.6 of CP#28) will be posted on the ICC website on or before April 2, 2018.

Internal ID: 1982

P26-18

IPC: 404.3 (New)

Proponent: Richard Anderson, None, representing Oklahoma ADAPT

2018 International Plumbing Code

Add new text as follows:

404.3 Accessible water closet personal hygiene device. Each accessible water closet shall be provided with a personal hygiene device in compliance with Section 412.9.

Reason:

Toilets with built in bidets are known to provide a cleaner and more hygienic experience after using the restroom. Many people install them in their homes because of the more soothing and comfortable wash they provide as opposed to dry toilet paper. However, bidet toilets can offer a lot more than just a more comfortable cleaning experience for those suffering from a variety of medical issues. Seniors and persons with disabilities have been known to have these in their homes (including me) to help with our bathroom usages due to the loss of muscle strength and gross motor skills.

Toilet bidets provides both physical and psychological relief, because it helps us go to the bathroom by ourselves again or for the first time in our life. However, this brilliant product that gives independence and a peace of mind for a lot of us hasn't made it to the ADA Guideline as far as public bathrooms are concern.

Personally, I'm scared of going out days, never knowing if you gonna have to go bad and if you are able to hold it til you get home. If you are able to transfer to the toilet, you shouldn't be thinking about how you going get clean when you can't wipe yourself (sorry to be blunt). It really amazes me the toilet bidets haven't already been added.

I would suggest hotels to have bidets in accessible rooms, any place that serves food, i.e. dinning in restaurants, stores that has dinning in restaurants in them, like wal-marts, malls which has restaurants in them, and concert/sporting venues be the major public bathrooms to have toilet with built-in bidets in accessible stalls

As you will notice, commercial bidet toilets costs a liittle more then a regular commercial toilets, but at the end, it will pay for itself and more, it will allow us to go on vacations, eat out, shop, etc. which puts more money back into the business, not to mention the economy.

Example

<https://www.houzz.com/photos/47714905/OVE-Decors-Smart-Toilet-contemporary-toilets>

Cost Impact

The code change proposal will increase the cost of construction .

As you will notice, commercial bidet toilets costs a liittle more then a regular commercial toilets, but at the end, **it will pay for itself and more**, it will allow us to go on vacations, eat out, shop, etc. which puts more money back into the business, not to mention the economy.

Internal ID: 583

P27-18

IPC: 405.3.1

Proponent: Daniel Gleiberman, SLOAN, representing SLOAN (dangleib@gmail.com)

2018 International Plumbing Code

Revise as follows:

405.3.1 Water closets, urinals, lavatories and bidets. A water closet, urinal, lavatory or bidet shall not be set closer than 15 inches (381 mm) from its center to any side wall, partition, vanity or other obstruction. ~~Where~~ For water closets, urinals, or bidets, where partitions or other obstructions do not separate adjacent fixtures, fixtures shall not be set closer than 30 inches (762 mm) center to center between adjacent fixtures. There shall be not less than a 21-inch (533 mm) clearance in front of a water closet, urinal, lavatory or bidet to any wall, fixture or door. Water closet compartments shall be not less than 30 inches (762 mm) in width and not less than 60 inches (1524 mm) in depth for floor-mounted water closets and not less than 30 inches (762 mm) in width and 56 inches (1422 mm) in depth for wall-hung water closets.

Exception: An accessible children's water closet shall be set not closer than 12 inches (305 mm) from its center to the required partition or to the wall on one side.

Reason:

This code section is a subsection of Section 405 entitled "Installation of Fixtures". This code change proposal clarifies that lavatories must be installed to meet the 15 inch separation from the center of the fixture to any obstruction.

Cost Impact

The code change proposal will not increase or decrease the cost of construction .

The change only clarifies the current code requirement.

Internal ID: 1930

P28-18

IPC: 405.3.4

Proponent: Bruce Pitts, Self, representing Self (bhpbhp@yahoo.com)

2018 International Plumbing Code

Revise as follows:

405.3.4 Water closet compartment. Each water closet utilized by the public or employees shall occupy a separate compartment with full-height walls or partitions and a solid door fully enclosing the fixtures to ensure privacy. The door shall close against seals on the top and sides, can be undercut up to 3/4 inches (19.05 mm) and shall not have a transfer grille.

Exceptions:

1. Water closet compartments shall not be required in a single-occupant toilet room with a lockable door.
2. Toilet rooms located in child day care facilities and containing two or more water closets shall be permitted to have one water closet without an enclosing compartment.
3. This provision is not applicable to toilet areas located within Group I-3 housing areas.
4. Door undercut height limitations are not required for exterior water closet compartments.

Reason:

Full-height partitions can help the Paruresis community function in society.

Paruresis affects from 6.6% to 14.4% of the population who find it difficult or impossible to urinate in the presence of others. Restroom privacy is the issue.

Employment, commerce, productivity and well being are affected. Many cannot work in buildings with partial-partition group restrooms and can plan their days around facilities that have restroom privacy. Paruresis contributes to agoraphobia and even to suicide.

Expecting this many people to seek and pay for treatment, which may or may not help them, is not the way to remedy this matter. 21 million is the population of Florida. 46 million represents the combined populations of Florida, New York State and South Carolina.

A Study by Williams and Degenhart - Journal of General Psychology 51:19-29, 1954, found 14.4% of the population having Paruresis, equaling 46 million Americans, based upon the 2015 USA population of 320,098,857. A Harvard University Study - Social Phobia Subtypes in the National Comorbidity Study - American Journal of Psychiatry, 155:613-9, May 1998, found 6.6% of the population with Paruresis equalling 21 million Americans as of 2015.

Closing each full-height partition door against seals (and with minimal door undercut) provides privacy and sound attenuation.

A maximum door undercut is not required for exterior toilet compartments to avoid vagrancy.

In the attachment section, a cost differential is provided for partial versus full-height partitions.

Cost Impact

The code change proposal will increase the cost of construction .

The cost of full-height versus partial-height partitions (attached) is nominal in relation to improving the lives of millions of Americans.

Partial versus full height toilet partition cost differential
 Quotes based upon Aiken, SC 29803, by Bruce Pitts 1/8/17

2 toilets men's
 2 urinals men's (not applicable for these toilet partition enclosures) 4
 toilets women's

Six partial height stall quantity and prices for both men's and women's rooms

	Quantity	Cost Each	Amount
ADA partial height toilet stall men's	1.0	\$1,567.80	\$1,568
Standard partial height toilet stall men's	1.0	\$1,303.00	\$1,303
ADA partial height toilet stall women's	1.0	\$1,567.80	\$1,568
Standard partial height toilet stall women's	3.0	\$1,303.00	\$3,909
Total cost partial height toilet stalls			\$8,348

Six full-height stall quantity and prices for both men's and women's rooms

	Quantity	Cost Each	Amount
Full height partitions with full doors total cost, 2 ADA and 4 standard stalls (see Note 1)			14,384.00
Additional exhaust ductwork	9.0	\$40.00	\$360
	L.F.	cost per L.F.	
Additional exhaust duct takeoff per grille	4.0	\$13.52	\$54
Additional ceiling exhaust grille	4.0	\$15.54	\$62
Total cost full height toilet stalls			\$14,860
Additional cost multiplier for the full height stalls			1.78

Note

1) Basic grade full height partition, floor to 8' ceiling sides and fronts with 3/4" undercut doors for exhaust make-up air and 4" vertical floor bases. Full height partition estimate per manufacturer's quote times 1.25 for installation, includes 2 full height ADA toilet stalls and 4 standard full height toilet stalls.

P29-18

IPC: 405.3.6 (New)

Proponent: Gary Schenk, City of SeaTac, WA, representing Washington Association of Building Officials (gschenk@ci.seatac.wa.us); Gary Lampella, City of Seatac WA, representing Washington Association of Building Officials TDC (garyl@nwcodeprofessionals.com)

2018 International Plumbing Code

Add new text as follows:

405.3.6 Privacy. Public restrooms shall be visually screened from outside entry or exit doors to ensure user privacy within the restroom. This provision shall also apply where mirrors would compromise personal privacy.

Exception:Visual screening shall not be required for single-occupant toilet rooms with lockable doors.

Reason:

Although this section currently has provisions for sidewall or partition privacy within the restrooms, it does not address privacy from viewing the user at the fixture from outside the restroom. It also addresses the placement of mirror reflection viewing from the outside.

Cost Impact

The code change proposal will not increase or decrease the cost of construction .

This is a minor design consideration that is typically addressed at the design stage. The change doesn't impact costs as the designers have been already considering this feature for a long time.

Internal ID: 2131

P30-18

IPC: 405.4.3, Chapter 15

Proponent: Angel Guzman Rodriguez, ASME, representing The American Society of Mechanical Engineers (ASME)

2018 International Plumbing Code

Revise as follows:

405.4.3 Securing wall-hung water closet bowls. Wall-hung water closet bowls shall be supported by a concealed metal carrier that is attached to the building structural members so that strain is not transmitted to the ~~closet fixture~~ connector or any other part of the plumbing system. The carrier shall conform to ASME A112.6.1M or ASME A112.6.2.

Add new standard(s) follows:

ASME

American Society of Mechanical
Engineers
Two Park Avenue
New York NY 10016-5990

A112.6.1M-1997 (R2017):

Floor Affixed Supports for Off-the-Floor Plumbing Fixtures for Public Use

Reason:

The ASME A112.6.1 Standard includes requirements for floor-affixed supports that can be used to secure off the floor water closets and urinals

Cost Impact

The code change proposal will not increase or decrease the cost of construction .

This proposal is only adding an optional type of carrier that can be used for securing a water closet bowl to a wall.

Analysis: A review of the standard proposed for inclusion in the code, ASME A112.6.1M-1997 (R2017), with regard to the ICC criteria for referenced standards (Section 3.6 of CP#28) will be posted on the ICC website on or before April 2, 2018.

Internal ID: 1403

P31-18

IPC: 407.2

Proponent: Pennie Feehan, representing Plumbing, Mechanical, and Fuel Gas Code Action Committee (PMGCAC@iccsafe.org)

2018 International Plumbing Code

Revise as follows:

407.2 Bathtub waste outlets and overflows. Bathtubs shall be equipped with a waste outlet ~~and an overflow outlet. The outlets shall be connected to waste tubing or piping that is~~ not less than 1½ inches (38 mm) in diameter. The waste outlet shall be equipped with a water-tight stopper. Where an overflow is installed, the overflow shall be not less than 1½ inches (38mm) in diameter.

Reason:

This proposal will coordinate the IRC requirements and IPC requirements for outlets from tubs. There are many bathtub designs that do not have overflow openings and the plumbing fixture standards do not require an overflow.

This proposal is submitted by the ICC Plumbing/Mechanical/Gas Code Action Committee (PMG CAC). The PMG CAC was established by the ICC Board of Directors to pursue opportunities to improve and enhance the International Codes or portions thereof that were under the purview of the PMG CAC. In 2017 the PMG CAC held one face-to-face meeting and 11 conference call meetings. Numerous interested parties attended the committee meetings and offered their input.

Cost Impact

The code change proposal will not increase or decrease the cost of construction .

This proposal will not increase the cost of construction because no additional labor, materials, equipment, appliances or devices are mandated beyond what is currently required by the code.

Internal ID: 562

P32-18

IPC: 408.1

Proponent: Pennie Feehan, representing Plumbing, Mechanical, and Fuel Gas Code Action Committee (PMGCAC@iccsafe.org)

2018 International Plumbing Code

Revise as follows:

408.1 Approval. Bidets shall conform to ASME A112.19.2/CSA B45.1- or ASME A112.19.3/CSA B45.4.

Reason:

The current standard reference is only for ceramic plumbing fixture. The additional standard addresses stainless steel plumbing fixtures. The standard is already referenced in the IPC for other fixtures.

This proposal is submitted by the ICC Plumbing/Mechanical/Gas Code Action Committee (PMG CAC). The PMG CAC was established by the ICC Board of Directors to pursue opportunities to improve and enhance the International Codes or portions thereof that were under the purview of the PMG CAC. In 2017 the PMG CAC held one face-to-face meeting and 11 conference call meetings. Numerous interested parties attended the committee meetings and offered their input.

Cost Impact

The code change proposal will not increase or decrease the cost of construction .

The addition of the standard provides more flexibility in choice of fixtures. A stainless steel bidet is not required to be installed; it is a choice that the designer can make.

Internal ID: 492

P33-18 Part I

IPC: 408.3

Proponent: William Chapin, Professional Code Consulting, LLC, representing Professional Code Consulting, LLC (bill@profcc.us)

THIS IS A 2 PART CODE CHANGE PROPOSAL. PART I WILL BE HEARD BY THE IPC COMMITTEE. PART II WILL BE HEARD BY THE IRC-PLUMBING COMMITTEE. SEE THE TENTATIVE HEARING ORDERS FOR THESE COMMITTEES.

2018 International Plumbing Code

Revise as follows:

408.3 Bidet water temperature. The discharge water temperature from a bidet fitting shall be limited to not greater than 110°F (43°C) by a water-temperature-limiting device conforming to ASSE 1070/ASME A112.1070/CSA B125.70 ~~or CSA B125.3.~~

Internal ID: 2237

P33-18 Part II

IRC: P2721.2

Proponent: William Chapin, Professional Code Consulting, LLC, representing Professional Code Consulting, LLC (bill@profcc.us)

2018 International Residential Code

Revise as follows:

P2721.2 Bidet water temperature. The discharge water temperature from a bidet fitting shall be limited to not greater than 110°F (43°C) by a water-temperature-limiting device conforming to ASSE 1070/ASME A112.1070/CSA B125.70 ~~or CSA B125.3~~.

Reason:

In June of 2017, the CSA B125 Committee completed the project that removed the automatic compensating valve requirements from CSA B125.3. The reason for this was the publication of harmonized ASSE 1070/ASME A112.1070/CSA B125.70 standard.

Cost Impact

The code change proposal will not increase or decrease the cost of construction .

Proposal on removes a referenced standard from the code section.

Internal ID: 3436

P34-18

IPC: 408.3, 412.3, 412.4, 412.5, 412.7

Proponent: James Kendzel, representing American Supply Association (jkendzel@asa.net)

2018 International Plumbing Code

Revise as follows:

408.3 Bidet water temperature. The discharge water temperature from a bidet fitting shall be limited to not greater than 110°F (43°C) by a water-temperature-limiting device conforming to ASSE 1070/ASME A112.1070/CSA B125.70 or CSA B125.3. The water heater thermostat shall not be used to control the bidet fitting outlet water temperature.

412.3 Individual shower valves. Individual shower and tubshower combination valves shall be balanced-pressure, thermostatic or combination balanced-pressure/thermostatic valves that conform to the requirements of ASSE 1016/ASME A112.1016/CSA B125.16 or ASME A112.18.1/CSA B125.1 and shall be installed at the point of use. Shower and tub-shower combination valves required by this section shall be equipped with a means to limit the maximum setting of the valve to 120°F (49°C), which shall be field adjusted in accordance with the manufacturer's instructions. In-line thermostatic valves shall not be utilized for compliance with this section. The water heater thermostat shall not be used to control the shower control outlet water temperature.

412.4 Multiple (gang) showers. Multiple (gang) showers supplied with a single-tempered water supply pipe shall have the water supply for such showers controlled by an *approved* automatic temperature control mixing valve that conforms to ASSE 1069 or CSA B125.3, or each shower head shall be individually controlled by a balanced-pressure, thermostatic or combination balanced-pressure/thermostatic valve that conforms to ASSE 1016/ASME A112.1016/CSA B125.16 or ASME A112.18.1/CSA B125.1 and is installed at the point of use. Such valves shall be equipped with a means to limit the maximum setting of the valve to 120°F (49°C), which shall be field adjusted in accordance with the manufacturers' instructions. The water heater thermostat shall not be used to control the shower outlet water temperature.

412.5 Bathtub and whirlpool bathtub valves. The *hot water* supplied to bathtubs and whirlpool bathtubs shall be limited to not greater than 120°F (49°C) by a water-temperature limiting device that conforms to ASSE 1070/ASME A112.1070/CSA B125.70 or CSA B125.3, except where such protection is otherwise provided by a combination tub/shower valve in accordance with Section 412.3. The water heater thermostat shall not be used to control the tub fixture fitting outlet water temperature.

412.7 Temperature-actuated, flow-reduction devices for individual fixture fittings. Temperature-actuated, flow-reduction devices, where installed for individual fixture fittings, shall conform to ASSE 1062. A temperature-actuated, flow-reduction device shall be an *approved* method for limiting the water temperature to not greater than 120° F (49° C) at the outlet of a faucet or fixture fitting. Such devices shall not be used alone as a substitute for the balanced-pressure, thermostatic or combination shower valves required in Section 412.3 or as a substitute for bathtub or whirlpool tub watertemperature-limiting valves required in Section 412.5. The water heater thermostat shall not be used to control the outlet water temperature from any fixture fitting.

Reason:

Added statement is intended to emphasize that a water heater thermostat is not a product covered by the referenced standards and is not intended for tempering water at the fixture.

Cost Impact

The code change proposal will not increase or decrease the cost of construction .

Added language is to ensure proper interpretations of the sections and as it is a clarification statement only there is no cost associated with the revision.

Internal ID: 840

P35-18

IPC: 408.3, Chapter 15

Proponent: Julius Ballanco, JB Engineering and Code Consulting, P.C., representing Bradley Corporation (JBEngineer@aol.com)

2018 International Plumbing Code

Revise as follows:

408.3 Bidet water temperature. The discharge water temperature from a bidet fitting shall be limited to not greater than 110°F (43°C). The water temperature shall be regulated by a water temperature heater conforming to ASSE 1084 or by a limiting device conforming to either ASSE 1070/ASME A112.1070/CSA B125.70 or CSA B125.3.

Add new standard(s) follows:

ASSE

ASSE International
18927 Hickory Creek Drive, Suite
220
Mokena IL 60448

1084-2018:

Performance Requirements for Water Heaters used as Temperature Limiting Devices

Reason:

A new standard, ASSE 1084, was developed for water heaters that limit the temperature of hot water similar to an ASSE1070 valve. The standard is comparable to ASSE 10710/ASME A112.1070/CSA B125.7. The water heater cannot produce a temperature of hot water exceeding 120° F. The water heater must be capable of shutting off the supply of hot water when the temperature exceeds the set limit. These water heaters may be installed in the close proximity of the fixtures they serve.

Cost Impact

The code change proposal will decrease the cost of construction .

The availability of more options to achieve code compliance usually results in lower construction costs.

Analysis: A review of the standard proposed for inclusion in the code, ASSE 1084 2018, with regard to the ICC criteria for referenced standards (Section 3.6 of CP#28) will be posted on the ICC website on or before April 2, 2018.

Internal ID: 1162

P36-18

IPC: 410.1

Proponent: Pennie Feehan, representing Plumbing, Mechanical, and Fuel Gas Code Action Committee (PMGCAC@iccsafe.org)

2018 International Plumbing Code

Revise as follows:

410.1 Approval. Drinking fountains shall conform to ASME A112.19.1/CSA B45.2 or ASME A112.19.2/CSA B45.1, or ASME A112.19.3/CSA B45.4 and *water coolers* shall conform to ASHRAE 18. Drinking fountains, *water coolers* and *water dispensers* shall conform to NSF 61, Section 9. Electrically operated, refrigerated drinking *water coolers* and *water dispensers* shall be listed and labeled in accordance with UL 399.

Reason:

The current standards reference ceramic, enameled cast iron and enameled steel plumbing fixtures. The additional standard addresses stainless steel plumbing fixtures. The standard is already referenced in the IPC for other fixtures.

This proposal is submitted by the ICC Plumbing/Mechanical/Gas Code Action Committee (PMG CAC). The PMG CAC was established by the ICC Board of Directors to pursue opportunities to improve and enhance the International Codes or portions thereof that were under the purview of the PMG CAC. In 2017 the PMG CAC held one face-to-face meeting and 11 conference call meetings. Numerous interested parties attended the committee meetings and offered their input.

Cost Impact

The code change proposal will not increase or decrease the cost of construction .

The addition of the standard provides more flexibility in choice of fixtures. A stainless steel drinking fountain is not required to be installed; it is a choice that the designer can make.

Internal ID: 493

P37-18

IPC: 410.2, 410.4, TABLE 403.1

Proponent: James Kendzel, American Supply Association, representing American Supply Association (jkendzel@asa.net)

2018 International Plumbing Code

Revise as follows:

410.2 ~~Small occupancies.~~ Number of drinking fountains. ~~Drinking-~~The number of drinking fountains required shall not be required for an occupant load of 15 or fewer. be in accordance with Table 403.1.

Delete without substitution:

410.4 ~~Substitution.~~ ~~Where restaurants provide drinking water in a container free of charge, drinking fountains shall not be required in those restaurants. In other occupancies where drinking fountains are required, *water dispensers* shall be permitted to be substituted for not more than 50 percent of the required number of drinking fountains.~~

Revise as follows:

**TABLE 403.1
MINIMUM NUMBER OF REQUIRED PLUMBING FIXTURES^a (See Sections 403.1.1 and 403.2)**

NO.	CLASSIFICATION	DESCRIPTION	WATER CLOSETS (URINALS; SEE SECTION 424.2)		LAVATORIES		BATHTUBS/ SHOWERS	DRINKING FOUNTAIN ^b (SEE SECTION 419)	OTHER
			MALE	FEMALE	MALE	FEMALE			
1	Assembly	Theaters and other buildings for the performing arts and motion pictures ^c	1 per 125	1 per 65	1 per 200		—	1 per 500	1 service sink
		Nightclubs, bars, taverns, dance halls and buildings for similar purposes ^d	1 per 40	1 per 40	1 per 75		—	1 per 500	1 service sink
		Restaurants, banquet halls and food courts ^d	1 per 75	1 per 75	1 per 200		—	1 per 500	1 service sink
		Casino gaming areas	1 per 100 for the first 400 and 1 per 250 for the remainder exceeding 400	1 per 50 for the first 400 and 1 per 150 for the remainder exceeding 400	1 per 250 for the first 750 and 1 per 500 for the remainder exceeding 750		—	1 per 1,000	1 service sink
		Auditoriums without permanent seating, art galleries, exhibition halls, museums, lecture halls, libraries, arcades and gymnasiums ^d	1 per 125	1 per 65	1 per 200		—	1 per 500	1 service sink
		Passenger terminals and transportation facilities ^e	1 per 500	1 per 500	1 per 750		—	1 per 1,000	1 service sink
		Places of worship and other religious services ^f	1 per 150	1 per 75	1 per 200		—	1 per 1,000	1 service sink
		Coleseums, arenas, skating rinks, pools and tennis courts for indoor sporting events and activities	1 per 75 for the first 1,500 and 1 per 120 for the remainder exceeding 1,500	1 per 40 for the first 1,520 and 1 per 60 for the remainder exceeding 1,520	1 per 200	1 per 150	—	1 per 1,000	1 service sink
		Stadiums, amusement parks, bleachers and grandstands for outdoor sporting events and activities ^g	1 per 75 for the first 1,500 and 1 per 120 for the remainder exceeding 1,500	1 per 40 for the first 1,520 and 1 per 60 for the remainder exceeding 1,520	1 per 200	1 per 150	—	1 per 1,000	1 service sink
2	Business	Buildings for the transaction of business, professional services, other services involving merchandise, office buildings, banks, light industrial, ambulatory care and similar uses	1 per 25 for the first 50 and 1 per 50 for the remainder exceeding 50		1 per 40 for the first 80 and 1 per 80 for the remainder exceeding 80		—	1 per 100	1 service sink ^h
3	Educational	Educational facilities	1 per 50		1 per 50		—	1 per 100	1 service sink
4	Factory and industrial	Structures in which occupants are engaged in work fabricating, assembly or processing of materials or	1 per 100		1 per 100		—	1 per 400	1 service sink

		materials					
5	Institutional	Custodial care facilities	1 per 10	1 per 10	1 per 8	1 per 100	1 service sink
		Medical care recipients in hospitals and nursing homes	1 per room ^c	1 per room ^c	1 per 15	1 per 100	1 service sink per floor
		Employees in hospitals and nursing homes ^b	1 per 25	1 per 35	—	1 per 100	—
		Visitors in hospitals and nursing homes	1 per 75	1 per 100	—	1 per 500	—
		Prisons ^b	1 per cell	1 per cell	1 per 15	1 per 100	1 service sink
		Reformatories, detention centers, and correctional centers ^c	1 per 15	1 per 15	1 per 15	1 per 100	1 service sink
		Employees in reformatories, detention centers and correctional centers ^c	1 per 25	1 per 35	—	1 per 100	—
		Adult day care and child day care	1 per 15	1 per 15	1	1 per 100	1 service sink
6	Mercantile	Retail stores, service stations, shops, sales rooms, markets and shopping centers	1 per 500	1 per 750	—	1 per 1,000	1 service sink ^a
7	Residential	Hotels, motels, boarding houses (transient)	1 per sleeping unit	1 per sleeping unit	1 per sleeping unit	—	1 service sink
		Dormitories, fraternities, sororities and boarding houses (not transient)	1 per 10	1 per 10	1 per 8	1 per 100	1 service sink
		Apartment house	1 per dwelling unit	1 per dwelling unit	1 per dwelling unit	—	1 kitchen sink per dwelling unit; 1 automatic clothes washer connection per 20 dwelling units
		Congregate living facilities with 15 or fewer persons	1 per 10	1 per 10	1 per 8	1 per 100	1 service sink
		One- and two-family dwellings and lodging houses with five or fewer guest rooms	1 per dwelling unit	1 per dwelling unit	1 per dwelling unit	—	1 kitchen sink per dwelling unit; 1 automatic clothes washer connection per dwelling unit
8	Storage	Structures for the storage of goods, warehouses, storehouse and freight depots, Low and Moderate Hazard.	1 per 100	1 per 100	—	1 per 1,000	1 service sink

a. The fixtures shown are based on one fixture being the minimum required for the number of persons indicated or any fraction of the number of persons indicated. The number of occupants shall be determined by the International Building Code.

- b. Toilet facilities for employees shall be separate from facilities for inmates or care recipients.
- c. A single-occupant toilet room with one water closet and one lavatory serving not more than two adjacent patient sleeping units shall be permitted provided that each patient sleeping unit has direct access to the toilet room and provision for privacy for the toilet room user is provided.
- d. The occupant load for seasonal outdoor seating and entertainment areas shall be included when determining the minimum number of facilities required.
- e. For business and mercantile classifications with an occupant load of 15 or fewer, service sinks shall not be required.
- f. The required number and type of plumbing fixtures for outdoor public swimming pools shall be in accordance with Section 609 of the International Swimming Pool and Spa Code.
- g. Drinking fountains shall not be required for an occupant load of 15 or fewer. Where drinking fountains are required, water dispensers shall be permitted to be substituted provided that not more than 50 percent of the required number of drinking fountains are substituted with water dispensers.

Reason:

Table 403.1 provides the minimum requirements for plumbing fixtures, including drinking fountains. The proposed changes move requirements and exceptions for drinking water fountains currently provided in section 410 and place them directly into the table.

Section 410.4 has been placed as a footnote in table 403.1 however, the first sentence of section 410.4, "Where restaurants provide drinking water in a container free of charge, drinking fountains shall not be required in those restaurants." This requirement does not appear to be enforceable and may change due to change of ownership over time and no requirement is in place to ensure that the consumer is aware that free water shall be provided by those restaurants not complying with the minimum number of drinking fountain requirements.

Cost Impact

The code change proposal will increase the cost of construction .

There is the potential for a minor increase in cost for restaurant construction due to the proposed elimination of the exception for restaurants that serve water in a container for free. However, the elimination of the exception ensures that drinking water is available in all restaurants prior to opening.

Internal ID: 1354

P38-18 Part I

IBC: 202, 1109.5, 2902.7 (New)

Proponent: Jenifer Gilliland, City of Seattle, Washington, representing City of Seattle, Washington
(jenifer.gilliland@seattle.gov)

THIS IS A 2 PART CODE CHANGE. PART I AND PART II WILL BE HEARD BY THE PLUMBING CODE COMMITTEE. SEE THE TENTATIVE HEARING ORDER FOR THIS COMMITTEE.

2018 International Building Code

Add new definition as follows:

WATER DISPENSER. A plumbing fixture that is manually controlled by the user for the purpose of dispensing potable drinking water into a receptacle such as a cup, glass or bottle. Such fixture is connected to the potable water distribution system of the premises. This definition includes a freestanding apparatus for the same purpose that is not connected to the potable water distribution system and that is supplied with potable water from a container, bottle or reservoir.

Revise as follows:

~~1109.5 Drinking~~ High and low drinking fountains. Where drinking fountains are provided on an exterior site, on a floor or within a secured area, the drinking fountains shall be provided in accordance with Sections 1109.5.1 and 1109.5.2.

1109.5.1 Minimum number. Not fewer than two drinking fountains shall be provided. One drinking fountain shall comply with the requirements for people who use a wheelchair and one drinking fountain shall comply with the requirements for standing persons.

Exceptions:

1. A single drinking fountain with two separate spouts that complies with the requirements for people who use a wheelchair and standing persons shall be permitted to be substituted for two separate drinking fountains.
2. Where drinking fountains are primarily for children's use, drinking fountains for people using wheelchairs shall be permitted to comply with the children's provisions in ICC A117.1 and drinking fountains for standing children shall be permitted to provide the spout at 30 inches (762 mm) minimum above the floor.

1109.5.2 More than the minimum number. Where more than the minimum number of drinking fountains specified in Section 1109.5.1 is provided, 50 percent of the total number of drinking fountains provided shall comply with the requirements for persons who use a wheelchair and 50 percent of the total number of drinking fountains provided shall comply with the requirements for standing persons.

Exceptions:

1. Where 50 percent of the drinking fountains yields a fraction, 50 percent shall be permitted to be rounded up or down, provided that the total number of drinking fountains complying with this section equals 100 percent of the drinking fountains.
2. Where drinking fountains are primarily for children's use, drinking fountains for people using wheelchairs shall be permitted to comply with the children's provisions in ICC A117.1 and drinking fountains for standing children shall be permitted to provide the spout at 30 inches (762 mm) minimum above the floor.

[P] 2902.6 Small occupancies. Drinking fountains shall not be required for an occupant load of 15 or fewer.

Add new text as follows:

2902.7 Substitution. Where restaurants provide drinking water in a container free of charge, drinking fountains shall not be required in those restaurants. In other occupancies where more than two drinking fountains are required, water dispensers shall be permitted to be substituted for not more than 50 percent of the required number of drinking fountains.

Staff Note: In Part I, the intent is for the text in the IPC for the definition of water dispenser and Section 410.4 to be copied verbatim into the IBC as a new definition and new Section 2902.7. The Code Correlation Committee will decide, prior to publication of the codes, whether a scoping designation will be applied to this new definition and new section in the IBC. The title change of IBC Section 1109.5 is only editorial.

Internal ID: 1172

P38-18 Part II

IPC: 410.3 (New), [BE]410.3, 410.3.2(New), 410.4

Proponent: Jenifer Gilliland, City of Seattle, Washington, representing City of Seattle, Washington
(jenifer.gilliland@seattle.gov)

2018 International Plumbing Code

SECTION 202 GENERAL DEFINITIONS

WATER DISPENSER. A plumbing fixture that is manually controlled by the user for the purpose of dispensing potable drinking water into a receptacle such as a cup, glass or bottle. Such fixture is connected to the potable water distribution system of the premises. This definition includes a freestanding apparatus for the same purpose that is not connected to the potable water distribution system and that is supplied with potable water from a container, bottle or reservoir.

SECTION 410 DRINKING FOUNTAINS

410.2 Small occupancies. Drinking fountains shall not be required for an occupant load of 15 or fewer.

Add new text as follows:

410.3 High and low drinking fountains. Where drinking fountains are provided on an exterior site, on a floor or within a secured area, the drinking fountains shall be provided in accordance with Sections 410.3.1 and 410.3.2.

Revise as follows:

~~**[BE] 410.3 410.3.1 High and low drinking fountains Minimum number.**~~ ~~Where drinking fountains are required,~~ ~~not~~ Not fewer than two drinking fountains shall be provided. One drinking fountain shall comply with the requirements for people who use a wheelchair and one drinking fountain shall comply with the requirements for standing persons.

Exceptions:

1. A single drinking fountain with two separate spouts that complies with the requirements for people who use a wheelchair and standing persons shall be permitted to be substituted for two separate drinking fountains.
2. Where drinking fountains are primarily for children's use, the drinking fountains for people using wheelchairs shall be permitted to comply with the children's provisions in ICC A117.1 and drinking fountains for standing children shall be permitted to provide the spout at 30 inches (762 mm) minimum above the floor.

Add new text as follows:

410.3.2 More than the minimum number. Where more than the minimum number of drinking fountains specified in Section 1109.5.1 is provided, 50 percent of the total number of drinking fountains provided shall comply with the requirements for persons who use a wheelchair and 50 percent of the total number of drinking fountains provided shall comply with the requirements for standing persons.

Exceptions:

1. Where 50 percent of the drinking fountains yields a fraction, 50 percent shall be permitted to be rounded up or down, provided that the total number of drinking fountains complying with this section equals 100 percent of the drinking fountains.

2. Where drinking fountains are primarily for children's use, drinking fountains for people using wheelchairs shall be permitted to comply with the children's provisions in ICC A117.1 and drinking fountains for standing children shall be permitted to provide the spout at 30 inches (762 mm) minimum above the floor.

Revise as follows:

410.4 Substitution. Where restaurants provide drinking water in a container free of charge, drinking fountains shall not be required in those restaurants. In other occupancies where more than two drinking fountains are required, *water dispensers* shall be permitted to be substituted for not more than 50 percent of the required number of drinking fountains.

Reason:

It is important for both the building official and the plumbing inspector to fully understand the requirements for drinking fountains including when they can be eliminated, switched out, and when high/low drinking fountains are required. Currently, only a portion of the information is available in the IPC and IBC.

The IPC does not have language addressing two important points needed for accessible drinking fountains:

- 1) The IPC doesn't include the requirements found in the IBC that are based on where the fountain is being provided - per floor, per secure area, or outside.
- 2) The IPC doesn't address high/low requirements for three or more drinking fountains.

This proposal adds the relevant sections currently found in IBC to IPC. The changes to the language are editorial for coordination only. Current IPC Section 410.3 has additional words at the beginning which are not in the IBC and are not correct. Accessibility provisions apply to drinking fountains where provided, not only where required.

There also appears to be a conflict between the IPC allowing half of the drinking fountains to be switched out starting at two drinking fountains, and the accessibility requirement requiring at least two. Adding "two or more" to the IPC Section 410.4 will eliminate that conflict. This information should be repeated in IBC Chapter 29 along with the information that small occupancies do not have to have drinking fountains.

There is another change proposal to change the definition in the IPC for water dispensers. This proposal is totally separate, but it is the intent for the revised definition to be in the IBC if that change is successful.

Cost Impact

The code change proposal will not increase or decrease the cost of construction .

This is a coordination/clarification of existing requirements in the IBC and the IPC.

Staff note: In Part 2, the intent is for the text in the IBC Section 1109.5, 1109.5.1 and 1109.5.2 to be copied verbatim into the IPC as Sections 410.3, 410.3.1 and 410.3.2 . A [BE] is shown in front of the text to indicate this, however, code committee scoping will be officially determined at a later date. There is a revision to IPC Section 410.4.

Internal ID: 3452

P39-18

IPC: 410.4

Proponent: Dawn Anderson, representing self (gonedawning@yahoo.com); Dan Buuck, representing National Association of Home Builders (dbuuck@nahb.org); David Collins, representing the American Institute of Architects (dcollins@preview-group.com); Marsha Mazz, representing U.S. Access Board (mazz@Access-Board.gov); Dominic Marinelli, representing United Spinal Association (DMarinelli@accessibility-services.com)

2018 International Plumbing Code

Revise as follows:

410.4 Substitution. Where restaurants provide drinking water in a container free of charge, drinking fountains shall not be required in those restaurants. In other occupancies where three or more drinking fountains are required, *water dispensers* shall be permitted to be substituted for not more than 50 percent of the required number of drinking fountains.

[BE] 410.3 High and low drinking fountains. Where drinking fountains are required, not fewer than two drinking fountains shall be provided. One drinking fountain shall comply with the requirements for people who use a wheelchair and one drinking fountain shall comply with the requirements for standing persons.

Exceptions:

1. A single drinking fountain with two separate spouts that complies with the requirements for people who use a wheelchair and standing persons shall be permitted to be substituted for two separate drinking fountains.
2. Where drinking fountains are primarily for children's use, the drinking fountains for people using wheelchairs shall be permitted to comply with the children's provisions in ICC A117.1 and drinking fountains for standing children shall be permitted to provide the spout at 30 inches (762 mm) minimum above the floor.

Reason:

IPC 410.4 allows up to 50% of required drinking fountains to be substituted with water dispensers, which could be water bottle fillers or bottled water. This change attempts to remove a "gotcha" situation—using the tradeoff for where only two drinking fountains would be required without considering the requirements for high/low drinking fountains. Allowing for such a tradeoff is in conflict with high/low requirements in the IPC 410.3 and IBC Section 1109.5.

Cost Impact

The code change proposal will not increase or decrease the cost of construction .

The proposal will eliminate possible conflicts between the IPC and accessibility requirements. The change is only correlative and contains, in itself, no substantive changes.

Internal ID: 542

P40-18

IPC: 411, 411.1, 411.2, 411.3

Proponent: Ronald George, representing Self (Ron@Plumb-TechLLC.com)

2018 International Plumbing Code

Revise as follows:

411.2 Waste connection. Waste connections ~~shall not be required~~ or floor drains of adequate size and capacity shall be provided for for emergency showers and ~~eyewash stations~~ eye/facewash stations.

Exception: Waste connections or floor drains shall not be required where the code official determines that the flushing fluid will not cause structural damage and there will be no spread of chemicals or contaminants in the run-off.

SECTION 411 EMERGENCY SHOWERS AND ~~EYEWASH~~ EYE/FACE WASH STATIONS

411.1 Approval. Emergency showers and ~~eyewash~~ eye/facewash stations shall conform to ISEA Z358.1.

411.3 Water supply. Where hot and cold water is supplied to an emergency shower or ~~eyewash~~ eye/facewash station, the temperature of the water supply shall only be controlled by a temperature actuated mixing valve complying with ASSE 1071.

Reason:

Emergency fixtures will flow a minimum of 24 gallons per minute when a combination unit is activated. The units are required by the Industry Standard to flow for a minimum of 15 minutes. 15 minutes x 24 gallons per minute = 360 gallons of water or flushing fluid (that is equal to about seven, 55-gallon drums of liquid and chemicals spilling over for each fixture activated). 360 gallons of flushing fluid (water and chemicals) could cause significant damage to a building and in some cases it could be flushing of radioactive waste or other harmful chemicals that are in the run-off. If there are no drains provided for an emergency fixture, it also makes it difficult for a building owner to properly flush the fluid in the emergency fixture piping system on a weekly basis as recommended in the industry standard to eliminate stagnant water and bacteria from the piping system. Hospital utilize emergency fixtures in decontamination areas near the emergency room entrances, upstairs in the hospital labs they generally have emergency fixtures and research labs have them throughout. Those type of building could suffer significant damage and disruption for an emergency fixture activation when there is no waste connection or floor drain. Industrial facilities or warehouses, however typically have concrete floors and curbed containment areas which may not require a waste connection or floor drain. This code change allows the code official to make the decision of whether to allow an industrial facility to omit waste connections or drains when it is deemed not to be a structural damage hazard or chemical spread hazard for the building.

Cost Impact

The code change proposal will not increase or decrease the cost of construction .

This proposal simply clarifies what the industrial safety community already understands about the need for capture/containment of flush water from an emergency eye/face wash unit. Typically, the default is to provide a waste connection or floor drain for convenience of testing and easy cleanup after a actual event. However, in some circumstances, a waste connection or floor drain is not appropriate because the wastewater is "hazardous" to the drainage piping system or waste treatment processes downstream. In jurisdictions where code officials have forced waste connections or floor drains on every unit where the industrial safety experts don't want those connections, the exception allows for a cost decrease. In jurisdictions where where code officials don't see drainage provisions at a specific application and the industrial safety experts indicate that the wastewater is not hazardous to the typical drainage system, there will be a cost increase to add drainage means. On average, the overall industry-wide cost of construction is neither plus or minus because most builder designers are already doing the right thing.

Internal ID: 1869

P41-18

IPC: 411.3

Proponent: Ronald George, representing Self (Ron@Plumb-TechLLC.com)

2018 International Plumbing Code

Revise as follows:

411.3 Water supply. Where hot and cold water is supplied to an emergency shower or ~~eyewash~~eye/facewash station, the temperature of the water supply shall only be controlled by a temperature actuated mixing valve complying with ASSE 1071. The maximum temperature of the flushing fluid used for an eye/facewash station shall be 100° F (37.7°C).

Reason:

Medical experts say the maximum water temperature of water or flushing fluid flowing from an eyewash or eye/facewash is 100 F. Any higher temperature could damage the eyes. This should be included as a maximum temperature limit imposed upon combination emergency showers and washes or eye/facewashes. There are many new technologies for either water heaters or emergency fixture mixing valves being installed together in various combinations of heating equipment and tempering valves that can be installed and many of these combinations are untested. By placing this temperature limit in the code it allows the code official to test the fixtures for a maximum temperature.

Cost Impact

The code change proposal will not increase or decrease the cost of construction .

This is just a temperature setting for the valve that is already required by the code.

Internal ID: 2363

P42-18

IPC: 411.3, Chapter 15

Proponent: Julius Ballanco, JB Engineering and Code Consulting, P.C., representing Bradley Corporation (JBEngineer@aol.com)

2018 International Plumbing Code

Revise as follows:

411.3 Water supply. Where hot and cold water is supplied to an emergency shower or eyewash station, the temperature of the water supply shall only be controlled by a temperature actuated mixing valve complying with ASSE 1071. Where water is supplied directly to an emergency shower or eyewash station from a water heater, the water heater shall comply with ASSE 1085.

Add new standard(s) follows:

ASSE

ASSE International
18927 Hickory Creek Drive, Suite
220
Mokena IL 60448

1085-2018:

Performance Requirements for Water Heaters for Emergency Equipment

Reason:

A new standard, ASSE 1085, was developed for water heaters specifically designed for emergency fixtures. The standard is comparable to the valve standard, ASSE 1071. The water heater cannot produce a temperature of hot water exceeding 100° F. The water heater produces water within a minute at the tepid temperature range required for emergency fixtures. These water heaters are typically installed within the close proximity of the emergency fixture. This is an alternative methods for meeting the high flow rates for emergency showers without the need for adding to the hot water demand of the plumbing within the building.

Cost Impact

The code change proposal will decrease the cost of construction .

The availability of more options to achieve code compliance usually results in lower construction costs.

Analysis: A review of the standard proposed for inclusion in the code, ASSE 1085-2018, with regard to the ICC criteria for referenced standards (Section 3.6 of CP#28) will be posted on the ICC website on or before April 2, 2018.

Internal ID: 1165

P43-18

IPC: 412.2 (New)

Proponent: James Kendzel, American Supply Association, representing American Supply Association
(jkendzel@asa.net)

2018 International Plumbing Code

Add new text as follows:

412.2 Pre-rinse spray valves. Pre-rinse spray valves for commercial food service shall conform to ASME A112.18.1/CSA B125.1

Reason:

New section is being added to clarify that pre-rinse spray valves fall under the definition of fixture fitting and are covered under Section 412.

Cost Impact

The code change proposal will not increase or decrease the cost of construction .

New section is being added only to clarify the existing requirements of the IPC.

Internal ID: 911

P44-18 Part I

IPC: 412.3, 412.4, 412.5

Proponent: Pennie Feehan, representing Plumbing, Mechanical, and Fuel Gas Code Action Committee (PMGCAC@iccsafe.org)

THIS IS A 2 PART CODE CHANGE PROPOSAL. PART I WILL BE HEARD BY THE IPC COMMITTEE. PART II WILL BE HEARD BY THE IRC-PLUMBING COMMITTEE. SEE THE TENTATIVE HEARING ORDERS FOR THESE COMMITTEES.

2018 International Plumbing Code

Revise as follows:

412.3 Individual shower valves. Individual shower and tubshower combination valves shall be balanced-pressure, thermostatic or combination balanced-pressure/thermostatic valves that conform to the requirements of ASSE 1016/ASME A112.1016/CSA B125.16 or ASME A112.18.1/CSA B125.1 ~~and. Such valves shall be installed at the point of use.~~ Shower and tub-shower combination valves required by this section shall be equipped with a means to limit the maximum setting of the valve to 120°F (49°C), which shall be field adjusted in accordance with the manufacturer's instructions to provide water at a temperature not to exceed 120°F. In-line thermostatic valves shall not be utilized for compliance with this section.

412.4 Multiple (gang) showers. Multiple (gang) showers supplied with a single-tempered water supply pipe shall have the water supply for such showers controlled by an *approved* automatic temperature control mixing valve that conforms to ASSE 1069 or CSA B125.3, or each shower head shall be individually controlled by a balanced-pressure, thermostatic or combination balanced-pressure/thermostatic valve that conforms to ASSE 1016/ASME A112.1016/CSA B125.16 or ASME A112.18.1/CSA B125.1 and that is installed at the point of use. Such valves shall be equipped with a means to limit the maximum setting of the valve to 120°F (49°C), which shall be field adjusted in accordance with the manufacturers' instructions to provide water at a temperature not to exceed 120°F. Access shall be provided to a ASSE 1069 or CSA B125.3 valve..

412.5 Bathtub and whirlpool bathtub valves. ~~The hot water supplied to bathtubs~~ Bathtubs and whirlpool bathtubs ~~bathtub valves shall be limited to not greater than 120°F (49°C) have or be supplied by a water-temperature limiting device that conforms to ASSE 1070/ASME A112.1070/CSA B125.70 or CSA B125.3, except where such protection is otherwise provided by a~~ valves are combination tub/shower valve valves in accordance with Section 412.3. The water temperature limiting device required by this section shall be equipped with a means to limit the maximum setting of the device to 120°F (49°C), and, where adjustable, shall be field adjusted in accordance with the manufacturer's instructions to provide hot water at a temperature not to exceed (120°F (49°C)). Access shall be provided to water temperature limiting devices that conform to ASSE 1070/ASME A112.1070/CSA B125.70 or CSA B125.3.

Exception: Access is not required for non-adjustable water temperature limiting devices that conform to ASSE 1070/ASME A112.1070/CSA B125.70 or CSA B125.3 and are integral with a fixture fitting, provided that the fixture fitting itself can be accessed for replacement..

P44-18 Part II

IRC: P2708.4, P2713.3

Proponent: Pennie Feehan, representing Plumbing, Mechanical, and Fuel Gas Code Action Committee (PMGCAC@iccsafe.org)

2018 International Residential Code

Revise as follows:

P2708.4 Shower control valves. Individual shower and ~~tub/shower~~tubshower combination valves shall be equipped with control valves of the ~~pressure-balance~~balanced-pressure, thermostatic ~~-mixing~~or combination ~~balanced-pressure-balance/thermostatic-mixing~~valve types with a high limit stop in accordance with ~~thermostatic valves that conform to the requirements of ASSE 1016/ASME A112.1016/CSA B125.16. The high limit stop shall be set to limit the water temperature to not greater than 120°F (49°C). or ASME A112.18.1/CSA B125.1. Such valves shall be installed at the point of use. Shower and tub-shower combination valves required by this section shall be equipped with a means to limit the maximum setting of the valve to 120°F (49°C), which shall be field adjusted in accordance with the manufacturer's instructions to provide water at a temperature not to exceed 120°F. In-line thermostatic valves shall not be used~~utilized for compliance with this section.

P2713.3 Bathtub and whirlpool bathtub valves. Hot water supplied to bathtubs ~~Bathtubs~~ and whirlpool ~~bathtubs~~bathtub valves shall be limited to a temperature of not greater than 120°F (49°C) ~~have or be~~ supplied by a water-temperature limiting device that conforms to ASSE 1070/ASME A112.1070/CSA B125.70 or CSA B125.3, except where such ~~protection is otherwise provided by a~~valves are combination tub/shower ~~valve~~valves in accordance with Section ~~P2708.4.4~~412.3. The water temperature³ limiting device required by this section shall be equipped with a means to limit the maximum setting of the device to 120°F (49°C), and, where adjustable, shall be field adjusted in accordance with the manufacturer's instructions to provide hot water at a temperature not to exceed (120°F (49°C)). Access shall be provided to water temperature limiting devices that conform to ASSE 1070/ASME A112.1070/CSA B125.70 or CSA B125.3.

Exception: Access is not required for non-adjustable water temperature limiting devices that conform to ASSE 1070/ASME A112.1070/CSA B125.70 or CSA B125.3 and are integral with a fixture fitting, provided that the fixture fitting itself can be accessed for replacement.

Reason:

These three sections were not specific about actually requiring field adjustment of the temperature limiting devices to a not-to-exceed temperature. The language only required that the device had to have the capability of being adjusted and that field adjustment is required. The revised language makes the intent clear.

Neither Section 412.4 or 412.5 required access for the temperature limiting devices. Although it would seem that installers would intuitively understand the need for access, too often these devices end up being concealed in a wall or behind a permanently installed tub apron. The revised language makes the need for access clear.

The language of Section 412.5 needs updated to recognize some newer designs of tub valves that have integral water temperature limiting devices that comply with ASSE 1070/ASME A112.1070/CSA B125.70. These new designs of tub valves are factory-adjusted to limit the discharge water temperature to 120°F(49°C). These valves are not field-adjustable and require entire valve replacement should the temperature limiting device fail to work as intended.

This proposal is submitted by the ICC Plumbing/Mechanical/Gas Code Action Committee (PMG CAC). The PMG CAC was established by the ICC Board of Directors to pursue opportunities to improve and enhance the International Codes or portions thereof that were under the purview of the PMG CAC. In 2017 the PMG CAC held one face-to-face meeting and 11 conference call meetings. Numerous interested parties attended the committee meetings and offered their input.

Cost Impact

The code change proposal will not increase or decrease the cost of construction .

This proposal will not increase the cost of construction because no additional labor, materials, equipment, appliances or devices are mandated beyond what is currently required by the code.

Internal ID: 3470

P45-18 Part I

IPC: 412.3, 412.4, Chapter 15

Proponent: Julius Ballanco, JB Engineering and Code Consulting, P.C., representing Bradley Corporation (JBEngineer@aol.com)

THIS IS A 2 PART CODE CHANGE PROPOSAL. PART I WILL BE HEARD BY THE IPC COMMITTEE. PART II WILL BE HEARD BY THE IRC-PLUMBING COMMITTEE. SEE THE TENTATIVE HEARING ORDERS FOR THESE COMMITTEES.

2018 International Plumbing Code

Revise as follows:

412.3 Individual shower valves. Individual shower and tub-shower combination valves shall be balanced-pressure, thermostatic or combination balanced-pressure/thermostatic valves that conform to the requirements of ASSE 1016/ASME A112.1016/CSA B125.16 or ASME A112.18.1/CSA B125.1 and shall be installed at the point of use. Shower and tub-shower combination valves required by this section shall be equipped with a means to limit the maximum setting of the valve to 120°F (49°C), which shall be field-adjusted. ~~In-line thermostatic valves shall not be utilized for compliance with this section.~~ The means for regulating the maximum temperature shall be by one of following:

1. A field adjustment and setting of the maximum temperature limit means of the shower or tub-shower combination valve in accordance with the manufacturer's instructions.
2. A limiting device conforming to either ASSE 1070/ASME A112.1070/CSA B125.70 or CSA B125.3.
3. A thermostatic mixing valve conforming to ASSE 1017.
4. A water heater conforming to ASSE 1082.
5. A water heater conforming to ASSE 1084.
6. A temperature actuated flow reduction device conforming to ASSE 1062.

412.4 Multiple (gang) showers. Multiple (gang) showers supplied with a single-tempered water supply pipe shall have the water supply for such showers controlled by an *approved* automatic temperature control mixing valve that conforms to ASSE 1069 or CSA B125.3, or each shower head shall be individually controlled by a balanced-pressure, thermostatic or combination balanced-pressure/thermostatic valve that ~~conforms to ASSE 1016/ASME A112.1016/CSA B125.16 or ASME A112.18.1/CSA B125.1 and is installed at the point of use. Such valves shall be equipped with a means to limit the maximum setting of the valve to 120°F (49°C), which shall be field-adjusted in accordance with the manufacturers' instructions.~~ complies with Section 412.3.

Add new standard(s) follows:

ASSE

ASSE International
18927 Hickory Creek Drive, Suite
220
Mokena IL 60448

1082-18:

Performance Requirements for Water Heaters used as Temperature Control Devices for Hot Water Distribution Systems

1084-2018:

Performance Requirements for Water Heaters used as Temperature Limiting Devices

Analysis: A review of the standards proposed for inclusion in the code, ASSE 1084-2018 and ASSE1082-2018, with regard to the ICC criteria for referenced standards (Section 3.6 of CP#28) will be posted on the ICC website on or before April 2, 2018.

Internal ID: 1132

P45-18 Part II

IRC: P2708.4, Chapter 44

Proponent: Julius Ballanco, JB Engineering and Code Consulting, P.C., representing Bradley Corporation (JBEngineer@aol.com)

2018 International Residential Code

Revise as follows:

P2708.4 Shower control valves. Individual shower and tub/shower combination valves shall be equipped with control valves of the pressure-balance, thermostatic-mixing or combination pressure-balance/thermostatic-mixing valve types with a high limit stop in accordance with ASSE 1016/ASME A112.1016/CSA B125.16. ~~The high limit stop~~ A means shall be set provided to limit the water temperature to not greater than 120°F (49°C). ~~In-line thermostatic valves shall not be used for compliance with this section.~~ The means for regulating the maximum temperature shall be by one of the following:

1. A field adjustment and setting of the maximum temperature limit means of the shower or tub-shower combination valve in accordance with the manufacturer's instructions.
2. A limiting device conforming to either ASSE 1070/ASME A112.1070/CSA B125.70 or CSA B125.3.
3. A thermostatic mixing valve conforming to ASSE 1017.
4. A water heater conforming to ASSE 1082.
5. A water heater conforming to ASSE 1084.
6. A temperature actuated flow reduction device conforming to ASSE 1062.

Add new standard(s) follows:

ASSE

ASSE International
18927 Hickory Creek Drive, Suite
220
Mokena IL 60448

1082-2018:

Performance Requirements for Water Heaters Used as Temperature Control Devices for Hot Water Distribution Systems.

1084-2018:

Performance Requirements for Water Heaters used as Temperature Limiting Devices

Reason:

The scald prevention requirements for a shower valve are by the requirement for a balanced-pressure, thermostatic or combination balanced-pressure/thermostatic valves. The high temperature limit was originally added to protect children that play hot and cold while taking a shower. This was extended to protecting people who inadvertently turn up the temperature of the shower valve.

The current code only stipulates the setting of the limit stop on the fixture fitting or shower valve, however, other viable means are available for setting the maximum temperature. The other viable means are often superior to setting the limit stop on the fixture fitting.

When the limit stop is adjusted, it is based on the temperature setting of the water heater and the cold water temperature. If the cold water temperature drops, which happens in some areas during the winter months, the setting temperature drops. If the water heater is increased in temperature, the setting temperature rises. This phenomena does not occur when other means are used to regulate the high temperature.

Section 412.7 already permits the use of a TAFR complying with ASSE 1062 for controlling the water temperature discharging from a faucet. Hence, the identification of the standard in this section complements the requirements in Section 412.7.

A thermostatic mixing valve is an effective method of regulating the maximum temperature. The temperature is maintained within a few degrees depending on the flow rate. Scalding temperatures are in excess of this temperature. Other viable means of maintaining the water temperature to a maximum of 120° F are water heater meeting one of the two new standards.

The two new standard for water heaters are ASSE 1082 and ASSE 1084. These water heaters are equivalent to ASSE 1017 and ASSE 1070 respectively. As such, they have the capability of providing an equivalent level of performance as the corresponding mixing valve.

For Section 412.4, there is no need to repeat all of the requirements in Section 412.3. If an individual shower valve is installed in gang showers, the requirements of Section 412.3 automatically apply. The revision merely emphasizes this requirement.

The changes to the Residential Code will make the requirements consistent with the Plumbing Code.

Cost Impact

The code change proposal will decrease the cost of construction .

The availability of more options to achieve code compliance usually results in lower construction costs.

Analysis: A review of the standard proposed for inclusion in the code, ASSE 1082-2018 and ASSE 1084-2018, with regard to the ICC criteria for referenced standards (Section 3.6 of CP#28) will be posted on the ICC website on or before April 2, 2018.

Internal ID: 3497

P46-18 Part I

IPC: 412.3, 412.4

Proponent: Pennie Feehan, representing Plumbing, Mechanical, and Fuel Gas Code Action Committee (PMGCAC@iccsafe.org)

THIS IS A 2 PART CODE CHANGE PROPOSAL. PART I WILL BE HEARD BY THE IPC COMMITTEE. PART II WILL BE HEARD BY THE IRC-PLUMBING COMMITTEE. SEE THE TENTATIVE HEARING ORDERS FOR THESE COMMITTEES.

2018 International Plumbing Code

Revise as follows:

412.3 Individual shower valves. Individual shower and tubshower combination valves shall be balanced-pressure, thermostatic or combination balanced-pressure/thermostatic valves that conform to the requirements of ASSE 1016/ASME A112.1016/CSA B125.16 or ASME A112.18.1/CSA B125.1 and shall be installed at the point of use. Shower control valves shall be rated for the flow rate of the installed showerhead. Shower and tub-shower combination valves required by this section shall be equipped with a means to limit the maximum setting of the valve to 120°F (49°C), which shall be field adjusted in accordance with the manufacturer's instructions. In-line thermostatic valves shall not be utilized for compliance with this section.

412.4 Multiple (gang) showers. Multiple (gang) showers supplied with a single-tempered water supply pipe shall have the water supply for such showers controlled by an *approved* automatic temperature control mixing valve that conforms to ASSE 1069 or CSA B125.3, or each shower head shall be individually controlled by a balanced-pressure, thermostatic or combination balanced-pressure/thermostatic valve that conforms to ASSE 1016/ASME A112.1016/CSA B125.16 or ASME A112.18.1/CSA B125.1 and is installed at the point of use. Where a showerhead is individually controlled, shower control valves shall be rated for the flow rate of the installed showerhead. Such valves shall be equipped with a means to limit the maximum setting of the valve to 120°F (49°C), which shall be field adjusted in accordance with the manufacturers' instructions.

Internal ID: 577

P46-18 Part II

IRC: P2708.4

Proponent: Pennie Feehan, representing Plumbing, Mechanical, and Fuel Gas Code Action Committee (PMGCAC@iccsafe.org)

2018 International Residential Code

Revise as follows:

P2708.4 Shower control valves. Individual shower and tub/shower combination valves shall be equipped with control valves of the pressure-balance, thermostatic-mixing or combination pressure-balance/thermostatic-mixing valve types with a high limit stop in accordance with ASSE 1016/ASME A112.1016/CSA B125.16. Shower control valves shall be rated for the flow rate of the installed showerhead. The high limit stop shall be set to limit the water temperature to not greater than 120°F (49°C). In-line thermostatic valves shall not be used for compliance with this section.

Reason:

The thermal protection afforded by shower valves can be compromised if the flow rate of the showerhead is less than the flow rate for which the protective components of the valve have been designed. The proposed text is consistent with similar requirements found in ASSE 1016/ASME A112.1016/CSA B125.16 and ASME A112.18.1/CSA B125.1. As manufacturers continue to innovate with more water- and energy-efficient showerheads, this proposal is needed to ensure that new buildings built to the code will safely accommodate the showerheads selected by the designer or builder. Note that this language does not require that the showerhead itself have a flow rate of less than 2.5 gpm, but simply that the flow rating of the shower valve matches the flow rate of the installed showerhead to provide the scald and thermal shock protection required by the recognized standard when the valve model is tested.

Note that the 2012 Uniform Plumbing Code, Section 408.3, contains a similar requirement for 'matching' the valve and showerhead flow rates as follows:

"Showers and tub-shower combinations shall be provided with individual control valves of the pressure balance, thermostatic, or combination pressure balance/thermostatic mixing valve type that provide scald and thermal shock protection for the rated flow of the installed showerhead."

The IPC and IRC should be no less protective of health and safety than the UPC.

This proposal is submitted by the ICC Plumbing/Mechanical/Gas Code Action Committee (PMG CAC). The PMG CAC was established by the ICC Board of Directors to pursue opportunities to improve and enhance the International Codes or portions thereof that were under the purview of the PMG CAC. In 2017 the PMG CAC held one face-to-face meeting and 11 conference call meetings. Numerous interested parties attended the committee meetings and offered their input.

Cost Impact

The code change proposal will not increase or decrease the cost of construction .

Adoption of this proposal will have no effect on the cost of construction, because it calls for the installation of showerheads and shower mixing valves that are compatible, rather than calling for the installation of a particular showerhead or shower control valve that might carry a cost premium. Care in specification and installation is required, not a special product or special installation technique. As noted above, the proposal does not require that the showerhead itself have a flow rate of less than 2.5 gpm, and compliance can be achieved with minimally compliant valves and showerheads. If an architect or builder chooses to install a more efficient showerhead with a lower flow rate, there are control valves available at moderate price points that can accommodate the builder's decision.

Internal ID: 3428

P47-18 Part I

IPC: 412.5

Proponent: William Chapin, Professional Code Consulting, LLC, representing Professional Code Consulting, LLC (bill@profcc.us)

THIS IS A 2 PART CODE CHANGE PROPOSAL. PART I WILL BE HEARD BY THE IPC COMMITTEE. PART II WILL BE HEARD BY THE IRC-PLUMBING COMMITTEE. SEE THE TENTATIVE HEARING ORDERS FOR THESE COMMITTEES.

2018 International Plumbing Code

Revise as follows:

412.5 Bathtub and whirlpool bathtub valves. The *hot water* supplied to bathtubs and whirlpool bathtubs shall be limited to not greater than 120°F (49°C) by a water-temperature limiting device that conforms to ASSE 1070/ASME A112.1070/CSA B125.70 ~~or CSA B125.3~~, except where such protection is otherwise provided by a combination tub/shower valve in accordance with Section 412.3.

Internal ID: 2245

P47-18 Part II

IRC: P2713.3

Proponent: William Chapin, Professional Code Consulting, LLC, representing Professional Code Consulting, LLC (bill@profcc.us)

2018 International Residential Code

Revise as follows:

P2713.3 Bathtub and whirlpool bathtub valves. Hot water supplied to bathtubs and whirlpool bathtubs shall be limited to a temperature of not greater than 120°F (49°C) by a water-temperature limiting device that conforms to ASSE 1070/ASME A112.1070/CSA B125.70 ~~or CSA B125.3~~, except where such protection is otherwise provided by a combination tub/shower valve in accordance with Section P2708.4.

Reason:

In June of 2017, the CSA B125 Committee completed the project that removed the automatic compensating valve requirements from CSA B125.3. The reason for this was the publication of harmonized ASSE 1070/ASME A112.1070/CSA B125.70 standard.

Cost Impact

The code change proposal will not increase or decrease the cost of construction .

Proposal only removes a referenced standard from the code section.

Internal ID: 3434

P48-18 Part I

IPC: 412.5, Chapter 15

Proponent: Misty Guard, representing Bradley Corporation (Misty.Guard@bradleycorp.com)

THIS IS A 2 PART CODE CHANGE PROPOSAL. PART I WILL BE HEARD BY THE IPC COMMITTEE. PART II WILL BE HEARD BY THE IRC-PLUMBING COMMITTEE. SEE THE TENTATIVE HEARING ORDERS FOR THESE COMMITTEES.

2018 International Plumbing Code

Revise as follows:

412.5 Bathtub and whirlpool bathtub valves. The *hot water* supplied to bathtubs and whirlpool bathtubs shall be limited to not greater than 120°F (49°C) by a water-temperature limiting device that conforms to ASSE 1070/ASME A112.1070/CSA B125.70 or CSA B125.3 or by a water heater complying with ASSE 1082 or ASSE 1084, except where such protection is otherwise provided by a combination tub/shower valve in accordance with Section 412.3.

Add new standard(s) follows:

ASSE

ASSE International
18927 Hickory Creek Drive, Suite
220
Mokena IL 60448

1084-2018:

Performance Requirements for Water Heaters used as Temperature Limiting Devices

1082-2018:

Performance Requirements for Water Heaters Used as Temperature Control Devices for Hot Water Distribution Systems.

Analysis: A review of the standards proposed for inclusion in the code, ASSE 1084-2018 and ASSE1082-2018, with regard to the ICC criteria for referenced standards (Section 3.6 of CP#28) will be posted on the ICC website on or before April 2, 2018.

Internal ID: 1854

P48-18 Part II

IRC: P2713.3, Chapter 44

Proponent: Misty Guard, representing Bradley Corporation (Misty.Guard@bradleycorp.com)

2018 International Residential Code

Revise as follows:

P2713.3 Bathtub and whirlpool bathtub valves. Hot water supplied to bathtubs and whirlpool bathtubs shall be limited to a temperature of not greater than 120°F (49°C) by a water-temperature limiting device that conforms to ASSE 1070/ASME A112.1070/CSA B125.70 or CSA B125.3 or by a water heater complying with ASSE 1082 or ASSE 1084, except where such protection is otherwise provided by a combination tub/shower valve in accordance with Section P2708.4.

Add new standard(s) follows:

ASSE

ASSE International
18927 Hickory Creek Drive, Suite
220
Mokena IL 60448

1084-2018:

Performance Requirements for Water Heaters used as Temperature Limiting Devices

1082-2018:

Performance Requirements for Water Heaters Used as Temperature Control Devices for Hot Water Distribution Systems.

Reason:

There are two new standards for water heaters, ASSE 1082 and ASSE 1084. These water heaters are equivalent to ASSE 1017 and ASSE 1070 respectively. As such, they have the capability of providing an equivalent level of performance as the currently listed water-temperature limiting device.

Water heaters complying with either one of these standards can provide tempered water within a range of a few degrees depending on the flow rate. The temperature range is similar to the allowable temperature range for an ASSE 1070/ASME A112.1070/CSA B125.70 device. The two new standard for water heaters are ASSE 1082 and ASSE 1084. These water heaters are equivalent to ASSE 1017 and ASSE 1070 respectively. As such, they have the capability of providing an equivalent level of performance as the corresponding mixing valve.

Cost Impact

The code change proposal will not increase or decrease the cost of construction .

There is no cost associated with this change since the code change will merely provide other options for complying with the current requirements. There are no new mandatory requirements being added.

Analysis: A review of the standards proposed for inclusion in the code, ASSE 1084-2018 and ASSE1082-2018, with regard to the ICC criteria for referenced standards (Section 3.6 of CP#28) will be posted on the ICC website on or before April 2, 2018.

Internal ID: 1856

P49-18

IPC: 412.10, Chapter 15

Proponent: Misty Guard, representing Bradley Corporation (Misty.Guard@bradleycorp.com)

2018 International Plumbing Code

Revise as follows:

412.10 Head shampoo sink faucets. Head shampoo sink faucets shall be supplied with hot water that is limited to not more than 120°F (49°C) by a water-temperature-limiting device that conforms to ASSE 1070/ASME A112.1070/CSA B125.70 or by a water heater complying with ASSE 1082 or ASSE 1084. Each faucet shall have integral check valves to prevent crossover flow between the hot and cold water supply connections.

Add new standard(s) follows:

ASSE

ASSE International
18927 Hickory Creek Drive, Suite
220
Mokena IL 60448

1084-2018:

Performance Requirements for Water Heaters used as Temperature Limiting Devices

1082-2018:

Performance Requirements for Water Heaters Used as Temperature Control Devices for Hot Water Distribution Systems.

Reason:

There are two new standards for water heaters, ASSE 1082 and ASSE 1084. These water heaters are equivalent to ASSE 1017 and ASSE 1070 respectively. As such, they have the capability of providing an equivalent level of performance as the currently listed water-temperature limiting device.

Water heaters complying with either one of these standards can provide tempered water within a range of a few degrees depending on the flow rate. The temperature range is similar to the allowable temperature range for an ASSE 1070/ASME A112.1070/CSA B125.70 device.

Cost Impact

The code change proposal will not increase or decrease the cost of construction .

There is no cost associated with this change since the code change will merely provide other options for complying with the current requirements. There are no new mandatory requirements being added.

Analysis: A review of the standards proposed for inclusion in the code, ASSE 1084-2018 and ASSE1082-2018, with regard to the ICC criteria for referenced standards (Section 3.6 of CP#28) will be posted on the ICC website on or before April 2, 2018.

Internal ID: 2250

P50-18 Part I

IPC: 412.5, Chapter 15

Proponent: Julius Ballanco, JB Engineering and Code Consulting, P.C., representing Bradley Corporation (JBEngineer@aol.com)

THIS IS A 2 PART CODE CHANGE PROPOSAL. PART I WILL BE HEARD BY THE IPC COMMITTEE. PART II WILL BE HEARD BY THE IRC-PLUMBING COMMITTEE. SEE THE TENTATIVE HEARING ORDERS FOR THESE COMMITTEES.

2018 International Plumbing Code

Revise as follows:

412.5 Bathtub and whirlpool bathtub valves. The *hot water* supplied to bathtubs and whirlpool bathtubs shall be limited to not greater than 120°F (49°C) ~~by a~~The water temperature limiting device that conforms temperature shall be regulated by one of the following:

1. A limiting device conforming to ASSE 1070/ASME A112.1070/CSA B125.70 or CSA B125.3,
2. A thermostatic mixing valve conforming to ASSE 1017.
3. A water heater conforming to ASSE 1082.
4. A water heater conforming to ASSE 1084.

Exception: ~~except~~Water temperature regulation by one of the items indicated in this section shall not be required where such regulation is ~~Where such protection is otherwise provided by a combination tub/shower valve in accordance with Section 412.3.~~

Add new standard(s) follows:

ASSE

ASSE International
18927 Hickory Creek Drive, Suite
220
Mokena IL 60448

1084-2018:

Performance Requirements for Water Heaters used as Temperature Limiting Devices

1082-2018:

Performance Requirements for Water Heaters Used as Temperature Control Devices for Hot Water Distribution Systems.

Analysis: A review of the standards proposed for inclusion in the code, ASSE 1084-2018 and ASSE1082-2018, with regard to the ICC criteria for referenced standards (Section 3.6 of CP#28) will be posted on the ICC website on or before April 2, 2018.

Internal ID: 1150

P50-18 Part II

IRC: P2713.3, Chapter 44

Proponent: Julius Ballanco, JB Engineering and Code Consulting, P.C., representing Bradley Corporation (JBEngineer@aol.com)

2018 International Residential Code

Revise as follows:

P2713.3 Bathtub and whirlpool bathtub valves. *Hot water* supplied to bathtubs and whirlpool bathtubs shall be limited to not greater than 120°F (49°C) ~~by a~~The water temperature limiting device that conforms~~temperature shall be regulated by one of the following:~~

1. A limiting device conforming to ASSE 1070/ASME A112.1070/CSA B125.70 or CSA B125.3.
2. A thermostatic mixing valve conforming to ASSE 1017.
3. A water heater conforming to ASSE 1082.
4. A water heater conforming to ASSE 1084.

Exception:~~except~~Water temperature regulation by one of the items indicated in this section shall not be required where such regulation is~~Where such protection is otherwise provided by a combination tub/shower valve in accordance with Section 412.3.~~

Add new standard(s) follows:

ASSE

ASSE International
18927 Hickory Creek Drive, Suite
220
Mokena IL 60448

1082-2018:

Performance Requirements for Water Heaters used as Temperature Control Devices for Hot Water Distribution Systems

1084-2018:

Performance Requirements for Water Heaters used as Temperature Limiting Devices

Reason:

The requirement for regulating the maximum temperature of water for bathtubs and whirlpool bathtub is a scald prevention requirement. The current code allows the use of a device complying with ASSE 1070/ASME A112.1070/CSA B125.70 or CSA B125.3. This change identifies other viable methods of controlling the temperature of the hot water. The identification of the standard in this section complements the requirements in Section 412.7.

A thermostatic mixing valve is an effective method of regulating the maximum temperature. The temperature is maintained within a few degrees depending on the flow rate. Scalding temperatures are in excess of this temperature. Other viable means of maintaining the water temperature to a maximum of 120° F are water heater meeting one of the two new standards.

The two new standard for water heaters are ASSE 1082 and ASSE 1084. These water heaters are equivalent to ASSE 1017 and ASSE 1070 respectively. As such, they have the capability of providing an equivalent level of performance as the corresponding mixing valve.

The change to the Residential Code will make the requirements consistent with the Plumbing Code.

Cost Impact

The code change proposal will decrease the cost of construction .

The availability of more options to achieve code compliance usually results in lower construction costs.

Internal ID: 3499

P51-18

IPC: 412.10, Chapter 15

Proponent: Julius Ballanco, JB Engineering and Code Consulting, P.C., representing Bradley Corporation (JBEngineer@aol.com)

2018 International Plumbing Code

Revise as follows:

412.10 Head shampoo sink faucets. Head shampoo sink faucets shall be supplied with hot water that is limited to not more than 120°F (49°C) ~~by a water temperature limiting device that conforms to ASSE 1070/ASME A112.1070/CSA B125.70.~~ Each faucet shall have integral check valves to prevent crossover flow between the hot and cold water supply connections. The means for regulating the maximum temperature shall be one of the following:

1. A limiting device conforming to ASSE 1070/ASME A112.1070/CSA B125.70.
2. A thermostatic mixing valve conforming to ASSE 1017.
3. A water heater conforming to ASSE 1082.
4. A water heater conforming to ASSE 1084.
5. A temperature actuated flow reduction device conforming to ASSE 1062.

Add new standard(s) follows:

ASSE

ASSE International
18927 Hickory Creek Drive, Suite
220
Mokena IL 60448

1084-2018:

Performance Requirements for Water Heaters used as Temperature Limiting Devices

1082-2018:

Performance Requirements for Water Heaters Used as Temperature Control Devices for Hot Water Distribution Systems.

Reason:

The scald prevention requirements for head shampoo sink faucets is similar to the upper limit requirement for shower valves. There other viable means are available for setting the maximum temperature besides a device complying with ASSE 1070/ASME A112.1070/CSA B125.70. The other viable means of meeting the high temperature limit.

Section 412.7 already permits the use of a TAFR complying with ASSE 1062 for controlling the water temperature discharging from a faucet. Hence, the identification of the standard in this section complements the requirements in Section 412.7.

A thermostatic mixing valve is an effective method of regulating the maximum temperature. The temperature is maintained within a few degrees depending on the flow rate. Scalding temperatures are in excess of this temperature. Other viable means of maintaining the water temperature to a maximum of 120° F are water heater meeting one of the two new standards.

The two new standard for water heaters are ASSE 1082 and ASSE 1084. These water heaters are equivalent to ASSE 1017 and ASSE 1070 respectively. As such, they have the capability of providing an equivalent level of performance as the corresponding mixing valve.

Cost Impact

The code change proposal will decrease the cost of construction .

The availability of more options to achieve code compliance usually results in lower construction costs.

Analysis: A review of the standards proposed for inclusion in the code, ASSE 1084-2018 and ASSE1082-2018, with regard to the ICC criteria for referenced standards (Section 3.6 of CP#28) will be posted on the ICC website on or before April 2, 2018.

P52-18

IPC: 412.11 (New)

Proponent: Pennie Feehan, representing Plumbing, Mechanical, and Fuel Gas Code Action Committee (PMGCAC@iccsafe.org)

2018 International Plumbing Code

Add new text as follows:

412.11 Pre-rinse spray valve. Pre-rinse spray valves for commercial food service shall conform to ASME A112.18.1/CSA B125.1

Reason:

Currently the IPC does not address pre-rinse spray valves but these are in wide spread use for rinsing off dirty dishes prior to putting them through a commercial dishwasher. IPC Section 412.6 is not sufficiently clear enough as to whether it applies to pre-rinse spray valves. Therefore, this new section is needed.

This proposal is submitted by the ICC Plumbing/Mechanical/Gas Code Action Committee (PMG CAC). The PMG CAC was established by the ICC Board of Directors to pursue opportunities to improve and enhance the International Codes or portions thereof that were under the purview of the PMG CAC. In 2017 the PMG CAC held one face-to-face meeting and 11 conference call meetings. Numerous interested parties attended the committee meetings and offered their input.

Cost Impact

The code change proposal will not increase or decrease the cost of construction .

Pre-rinse spray valves are not required to be installed. It is a choice by the designer. Requiring that these valves comply with a standard doesn't increase the cost because most manufacturers are making these valves to the standard so that interchangeability exists.

Internal ID: 498

P53-18

IPC: 413.5 (New)

Proponent: James Richardson Jr, representing City of Columbus Ohio (jarichardson@columbus.gov); Robert Schutz, representing City of Columbus, OH (RJSchutz@columbus.gov)

2018 International Plumbing Code

Add new text as follows:

413.5 Floor slope to floor and trench drains. The floor surface in the area or room served by a floor or trench drain shall have a slope to such drains at not less than one-fourth unit vertical in 12 units horizontal (2-percent slope).

Reason:

This is long overdue. Everyone has seen this issue at some point in their life. There is some emergency situation and although there is an emergency floor drain/trench drain in the room or area, some water remains on the surface (sometimes several inches) due to the fact there is no real requirement for the area to have slope to the drain. In many cases the highest point in the room or area is actually the inlet to the floor drain/trench drain. It does seem odd that it is covered in great detail when we look at the requirements for a shower liner, however, a floor surface somehow doesn't matter. What many have failed to realize by overlooking this issue is that even though the floor drain/trench drain may be located in a concrete floor (with or without floor covering of some type), there are other portions of the building that can be greatly impacted. For instance, the walls that make up the room. Some assume these would be CMU units, but construction would allow for many other materials. If the walls were metal studs with drywall for instance, the metal studs could be subjected to deterioration from rust caused by the water that remained at the base of the wall because the surface was not sloped correctly. The drywall often becomes a breeding ground for mold as well.

Cost Impact

The code change proposal will not increase or decrease the cost of construction .

Sloping a floor to a floor or trench drain is simply a design call out for building drawings. The plumbing contractor already has to set the the top of the drains at the floor elevation called out on the drawings so there isn't any cost impact as no extra labor is necessary.

Internal ID: 2123

P54-18

IPC: 416.1

Proponent: Julius Ballanco, JB Engineering and Code Consulting, P.C., representing InSinkErator (JBENGINEER@aol.com)

2018 International Plumbing Code

Revise as follows:

416.1 Approval. Domestic food waste disposers shall conform to ASSE 1008 and shall be listed and labeled in accordance with UL 430. Commercial food waste disposers shall be listed and labeled in accordance with UL 430. Food waste disposers shall not increase the *drainage fixture unit* load on the sanitary drainage system.

Reason:

The current code requires domestic food waste disposers to conform with UL 430. However, this standard applies to both domestic and commercial food waste disposers. A second sentence has been added to address commercial food waste disposers. It should be noted that ASSE 1008 only applies to domestic food waste disposers, hence the word "commercial" cannot be added to the first sentence.

Cost Impact

The code change proposal will not increase or decrease the cost of construction .

Commercial disposers are already required to be listed. This merely adds reference to the correct standard for testing and listing.

Internal ID: 883

P55-18

IPC: 202, 419.1, 419.3

Proponent: Julius Ballanco, JB Engineering and Code Consulting, P.C., representing Bradley Corporation (JBENGINEER@aol.com); Daniel Gleiberman, SLOAN, representing SLOAN

2018 International Plumbing Code

Add new definition as follows:

GROUP WASH FIXTURE A type of lavatory that allows more than one person to utilize the fixture at the same time. The fixture has one or more drains and one or more faucets.

Revise as follows:

419.1 Approval. Lavatories shall conform to ASME A112.19.1/CSA B45.2, ASME A112.19.2/CSA B45.1, ASME A112.19.3/CSA B45.4 or CSA B45.5/IAPMO Z124. Group wash ~~up equipment fixtures~~ shall conform to the requirements of Section 402. ~~Every~~ For determining the number of lavatories required by Table 403.1, every 20 inches (508 mm) of rim space of a group wash fixture shall be considered as one lavatory.

419.3 Lavatory waste outlets. Lavatories and group wash fixtures shall have a waste outlets-outlet not less than 1¹/₄ inches (32 mm) in diameter. A strainer, pop-up stopper, crossbar or other device shall be provided to restrict the clear opening of the waste outlet.

Reason:

The current code uses two terms to describe the same fixture. In Section 419.1 the term “group wash-up equipment” is used. In Section 419.5, the term “group wash fixture” is used. The proper term used in the plumbing industry is “group wash fixture.”

Definitions of group wash fixture is being added. The group wash fixture definition identifies what the fixture is, including that there could be one or more drains and one or more faucets connected with the fixture.

The changes to the subsections in Section 419 become editorial in nature with the addition of the definitions. There is also clarification added that the 20 inches of rim space is only used for determining number of lavatories that are specified in Table 403.1. This is the only application of the 20 inches of rim space.

Cost Impact

The code change proposal will not increase or decrease the cost of construction .

The change clarifies the current code requirement.

Internal ID: 1504

P56-18

IPC: 419.5

Proponent: Gary Klein, representing Self (gsmklein@comcast.net)

2018 International Plumbing Code

Revise as follows:

419.5 Tempered water ~~Water for public hand-washing facilities. Tempered water shall be delivered from lavatories~~ Lavatories and group wash fixtures located in public toilet facilities ~~provided for customers, patrons and visitors. Tempered water shall be delivered through an approved water temperature limiting shall be provided with cold water, tempered water, or both. Where tempered water is supplied to such fixtures, the temperature shall be limited to 125°F (52°C) by means of temperature control device that conforms to ASSE 1070/ASME A112.1070/CSA B125.70, CSA B125.3 or ASSE 1017.~~

Reason:

The purpose of this code change proposal is to address the requirement to provide tempered water to public hand-washing facilities, to change the temperature of water delivered to public hand-washing facilities to a maximum of 125°F and to enable the use of either cold water or tempered water at public hand-washing facilities.

Most of the reasons supporting this proposal are discussed below. In addition, we are proposing that where tempered water is supplied to public hand-washing facilities its temperature can be controlled by either a local mixing valve (ASSE1070) or by a master mixing valve (ASSE 1017), depending on the configuration of the hot water distribution system.

Raising the maximum temperature for hand washing to 125F is still safe for scald prevention since people can easily remove their hands from water that is getting too hot too rapidly. It is also a better temperature to control the growth of Legionella in the hot water distribution system.

What follows is the reason statement that supports several code change proposals. There is one reason statement for these proposals because the topics are interrelated and a comprehensive discussion is most likely to result in the best outcome for protecting the public's health and safety.

Health and safety for public hand washing needs to include 1) scald prevention, 2) hand washing efficacy and 3) minimizing the risk of pathogen growth in the building's water distribution system.

We do not want the temperature of the water at public sinks to be too hot. We want the temperature of the water to be comfortable for the users of public sinks so that people will scrub their hands long enough to get them clean. We want to reduce the likelihood that pathogens will grow in the water distribution system. And, we would like to accomplish all of these health and safety functions in the most cost effective and sustainable manner possible.

At present, we believe that there are a few provisions in the IPC that inadvertently create a public health risk. Changing the temperature limits in this definition is one part of resolving this problem.

When the provisions in the current definitions and the related sections were first codified, Legionella was not a significant concern to public health; many items known today were unknown then. Now Legionella in building water systems has become a major concern for public health with the incidence of Legionnaires' disease growing by 500% from 0.4 cases per 100,000 people in 2000 to 2.0 cases per 100,000 people in 2015.¹

At the time these same provisions were codified, it used be thought that warm water was necessary for effective hand cleaning to control the spread of germs (bacteria). Science has since proven that the temperature of the water used for handwashing does not impact the efficacy of removing bacteria at all.^{2, 3, 4} While each of these three papers are very clear the CDC sums it up best with "The temperature of the water does not appear to affect microbe removal; however, warmer water may cause more skin irritation and is more environmentally costly"⁴ The most important variables for removing bacteria from ones hands are scrubbing and the use of soap. Neither of these criteria is within the purview of a building code.

When scald prevention was discussed as part of codifying these same provisions, the unintended consequences of lower water temperature on waterborne pathogen growth was not known. Accordingly temperature of 140°F originally proposed for scald control in home hot water heaters was lowered to 130°F and finally a recommendation of 120°F was made because if 140°F was OK it was thought that adding a huge safety margin would only be better, we now know that huge safety margin had serious and significant unintended consequences. A temperature of 120°F is considered an abundantly safe scald limit. However, setting water heaters this low results in much of the hot water distribution system being at temperatures that ideal for growing pathogens.

Since 1998 OSHA guidelines have stated that hot water should be stored at 140F and delivered at a temperature greater than 120F. In 2009, the CDC published a study documenting scalding cases resulting in hospital visits by the elderly from 2001-2006. The elderly are the highest risk population for Legionnaires' disease and one of the highest risk for scalding. They found that more than 80% of the scalding cases were due to cooking activities in the kitchen. Less than 3% (220 out of 8,620 cases) were plumbing related.¹³

We believe that it is time to use our current knowledge of these interrelated elements to improve health and safety by revising the a few of the temperature related provisions in the 2018 IPC and the 2018 IRC-P

In both the IPC and the IRC, hot water is required to be supplied to plumbing fixtures and plumbing appliances intended for bathing, washing, or culinary purposes. The 2018 IPC and IRC-P have two different maximum temperature thresholds, which some say are for scald prevention. The temperature at public hand washing sinks (lavatories), is limited to 110°F. With the exception of bidets and emergency fixtures, which are also limited to 110°F, all other fixtures are limited to 120°F. Please see the table below.

Water Temperature Provisions in the 2018 IPC and IRC-P

Fixture	Maximum Temperature	Section
Bidet	110F (43C)	IPC 408.3 IRC P2721.2
Emergency showers and eyewash stations	110F (43C)	IPC 411.1*
Individual shower valve	120F (49C)	IPC 412.3 IRC P2708.4
Multiple (gang) showers	120F (49C)	IPC 412.4
Temperature-actuated, flow-reduction devices for individual fixture fittings	120F (49C)	IPC 412.7
Public lavatories	110F (43C)	IPC 419.5
Bath tub and whirlpool tub	120F (49C)	IPC 412.5 IRC 2713.3
Head shampoo sink faucet	120F (49C)	IPC 412.10
Footbaths and pedicure baths	120F (49C)	IPC 423.3

* The maximum temperature is not shown in this IPC section, but rather in the referenced standard. This standard also has a minimum acceptable temperature of 60F for emergency fixtures. This lower number might be useful guidance for jurisdictions with cold incoming water temperatures that want to raise the temperature of cold water for hand washing during the winter months where only cold water is supplied to public lavatory faucets.

Bidets, emergency showers and eyewash stations and public lavatories are required to have tempered water supplied through a water temperature limiting device that conforms to the appropriate ASSE, ANSI or CSA standard. The upper limit of 110°F makes sense for bidets and emergency showers. It does not make sense for hand washing at public lavatories.

If 120°F is a safe temperature for showering, bathing, head shampooing, tubs, it is equally safe for hand washing at either public or private lavatory faucets. It does not make sense that the temperature is lower for hand washing than for tub bathing. If the water temperature rises quickly to an uncomfortably hot and unsafe number it is much easier to remove ones hands from the water coming out of the faucet than it is to get out of a bathtub or to get out of the way in a shower. There is no need to have a lower temperature supplied for hand washing than for showering or bathing. In fact this public lavatory temperature code is derived from ASHRAE 90.1 energy saving code, not safety.

In our research into this issue, we found that the 110°F temperature limitation for hand washing at public lavatories comes from an energy code, ASHRAE 90.1 (1989)⁵ "Energy Standard for Buildings Except Low-Rise Residential Buildings." Section 11.4.5.2 presents the provisions for lavatories in public facility restrooms (such as those in service stations, airports, train terminals, and convention halls). These include the requirement for low flow rates (the document preceded the 1990's era EPACT rules concerning public lavatory faucet flow rates) and for limiting the temperature to a maximum of 110°F.

In the very high use public toilets detailed in 90.1 (1989) the sinks are used many times per hour, and the combination of low temperature and low flow does not dramatically increase the health risks from waterborne pathogens; the very high turnover rates of the water in the piping brings in new disinfectant.

However, many toilet facilities currently classified as "public" are only used sporadically. The combination of low hot water temperature, low flow rate and infrequent usage, results in a very low turnover rate which in turn means that new disinfectant enters the piping very infrequently. This condition not only provides a localized incubation chamber for Legionella but once grown can result in contaminating the rest of the hot water system.

While the idea of establishing 85-110°F as a safe range for public hand washing seemed like a good idea at the time, it turns out this range is ideal for the growth of pathogens in the building's water distribution system. Pathogens that

affect humans grow in temperatures that are found in our bodies: 85-110°F. For example, Legionella reproduces at the highest rates in the range of 85-110°F. Legionnaires' disease, caused by Legionella growth in building water systems has become a major public health concern.

Adding to the risk due to temperature is the complexity of the internal components of the mixing valves and the lack of maintenance these valves typically receive. Such maintenance is relatively time consuming and costly and is often ignored. By way of comparison, Australian codes for health and safety purposes require these local mixing valves to be disassembled and disinfected annually^{6, 7, 8}

Conclusions and Recommendations:

If 120°F is safe enough to protect against scalding for bathing, it is safe enough for public hand washing. If this temperature is safe enough for Health Care Occupancies (IPC Section 609.3), it is safe enough for the other occupancies covered by the IPC.

Maintaining temperatures in the range of 85-110°F that is currently required in Section 419.5 is unsafe because it provides ideal conditions for the growth of pathogens, bacteria dangerous to humans. All Legionella guidelines including OSHA 1998⁹, ASHRAE 2000¹⁰, CDC 2003¹¹, and CDC 2016¹² recommend maintaining hot water temperatures at fixtures and in hot water return lines at or above 120°F.

It is not necessary to specify the temperature range for supplying water for hand washing in public lavatories, only the maximum temperature to prevent scalding.

We recommend that the maximum safe temperature for the discharge of hot water into public hand washing sinks be raised to 120°F.

We recommend moving the break point between tempered and hot water from 110°F to 120°F.

We recommend enabling the use of cold water only, or tempered water, or both at public hand washing sinks.

Bibliography:

US Centers for Disease Control (CDC) Atlanta, GA Chart titled, "Legionnaires' Disease is on the Rise 2000-2015*" National Notifiable Diseases Surveillance System <https://www.cdc.gov/legionella/downloads/fs-legionella-clinicians.pdf>

Quantifying the Effects of Water Temperature, Soap Volume, Lather Time, and Antimicrobial Soap as Variables in the Removal of Escherichia coli ATCC 11229 from Hands Journal of Food Protection June 2017 Dane A. Jensen,¹ David R. Macinga,² David J. Shumaker,² Roberto Bellino,² James W. Arbogast,² and Donald W. Schaffner¹ <http://jfoodprotection.com/doi/full/10.4315/0362-028X.JFP-16-370?code=fopr-site>

Above was in an article titled Cool Water as Effective as Hot for Removing Germs During Handwashing Infection Control Today May 30 2017

The environmental cost of misinformation: why the recommendation to use elevated temperatures for handwashing is problematic International Journal of Consumer Studies Volume 37, Issue 4 July 2013 Amanda R. Carrico, Micajah Spoden, Kenneth A. Wallston, Michael P. Vandenberg <http://onlinelibrary.wiley.com/doi/10.1111/ijcs.12012/abstract>

Show Me the Science - How to Wash Your Hands CDC Website <https://www.cdc.gov/handwashing/show-me-the-science-handwashing.html>

ASHRAE 90.1 (1989) "Energy Standard for Buildings Except Low-Rise Residential Buildings"

Guidelines for the Control of Legionella in Manufactured Water Systems in South Australia, 2008 revised 2013 <http://www.sahealth.sa.gov.au/wps/wcm/connect/d2f047804755f77e91f5d322c3ec38c5/LegionellaGuidelines+revised+2?MOD=AJPERES>

Department of Health & Human Services Victoria Australia Sept 2011 "Risk management plan for Legionella Control in health and aged care facilities" <https://www2.health.vic.gov.au/about/publications/policiesandguidelines/risk-management-plan-for-legionella-control-in-health-and-aged-care-facilities>

Australian Standard. Water supply. Valves for the control of heated water supply temperatures Part 3: Requirements for field-testing, maintenance or replacement of thermostatic mixing valves, tempering valves and end-of-line temperature control devices <https://www.saiglobal.com/PDFTemp/Previews/OSH/as/as4000/4000/40323.pdf>

Occupational Safety and Health Administration (OSHA) "Technical Manual Section III: Chapter 7 Legionnaires' Disease" 1998 https://www.osha.gov/dts/osta/otm/otm_iii/otm_iii_7.html

American Society of Heating, Refrigeration and Air-Conditioning Engineers, Inc. (ASHRAE) Guideline 12 "Minimizing the Risk of Legionellosis Associated with Building Water Systems" 2000

Centers for Disease Control and Prevention (CDC) Guidelines for Environmental Infection Control in Health-Care Facilities 2003 <https://www.cdc.gov/infectioncontrol/pdf/guidelines/environmental-guidelines.pdf>

Centers for Disease Control and Prevention (CDC) Developing a Water Management Program to Reduce Legionella Growth & Spread in Buildings | <https://www.cdc.gov/legionella/downloads/toolkit.pdf>

Centers for Disease Control and Prevention (CDC) MMWR Weekly September 18, 2009 / 58(36);993-996 "Nonfatal Scald-Related Burns Among Adults Aged ≥65 Years --- United States, 2001—2006" <https://www.cdc.gov/mmwr/preview/mmwrhtml/mm5836a1.htm>

Cost Impact

The code change proposal will decrease the cost of construction .

Justification:

This proposal enables the use of cold water, tempered water, or both to public hand-washing facilities. If only cold water is supplied, it will decrease construction costs by eliminating the installation of a hot water distribution system to these faucets and by eliminating the installation of the associated ASSE 1070 mixing valves, reducing or eliminating the water heater for this hot water and eliminating the mechanical space used by this piping and equipment. It will also eliminate the costs of operations and maintenance by reducing expenditures on hot water and on the maintenance of the mixing valves.

In places where city cold water is above 60°F year round, allowing only cold water to be supplied to public lavatories will eliminate much if not all the hot water piping and associated equipment in many buildings.

By virtue of raising the allowable maximum temperature to 120F it will now be possible to use a master-mixing valve (ASSE 1017) for temperature control instead of installing ASSE 1070 valves at every faucet. One valve costs less than many valves. Having fewer valves also dramatically reduces operating and maintenance costs.

Internal ID: 2306

P57-18

IPC: 419.5

Proponent: William Chapin, Professional Code Consulting, LLC, representing Professional Code Consulting, LLC (bill@profcc.us)

2018 International Plumbing Code

Revise as follows:

419.5 Tempered water for public hand-washing facilities. *Tempered water* shall be delivered from lavatories and group wash fixtures located in public toilet facilities provided for customers, patrons and visitors. *Tempered water* shall be delivered through an *approved* water-temperature limiting device that conforms to ASSE 1070/ASME A112.1070/CSA B125.70 ~~or CSA B125.3.~~

Reason:

In June of 2017, the CSA B125 Committee completed the project that removed the automatic compensating valve requirements from CSA B125.3. The reason for this was the publication of harmonized ASSE 1070/ASME A112.1070/CSA B125.70 standard.

Cost Impact

The code change proposal will not increase or decrease the cost of construction .

Proposal only removes a referenced standard from the code section.

Internal ID: 2249

P58-18 Part I

IPC: 202, 419.5

Proponent: Tim Keane, self, representing self (timke@verizon.net)

THIS IS A 2 PART CODE CHANGE PROPOSAL. PART I WILL BE HEARD BY THE IPC COMMITTEE. PART II WILL BE HEARD BY THE IRC-PLUMBING COMMITTEE. SEE THE TENTATIVE HEARING ORDERS FOR THESE COMMITTEES.

2018 International Plumbing Code

Revise as follows:

419.5 ~~Tempered water~~ Water for public hand-washing facilities.

~~Tempered water shall be delivered from lavatories~~ Lavatories and group wash fixtures located in public toilet facilities provided for customers, patrons and visitors. ~~Tempered water shall be delivered through an approved water-temperature-limiting shall be provided with cold water, tempered water, or both. Where tempered water is supplied to such fixtures, the temperature shall be limited to not greater than 120°F (49°C) by means of temperature control device that conforms to ASSE 1017, ASSE 1070/ASME A112.1070/CSA B125.70 or CSA B125.3.~~

HOT WATER. Water at a temperature greater than or equal to ~~110°F~~ 120°F (43°C/49°C):-

TEMPERED WATER. ~~Water having a temperature range between 85°F (29°C) and 110°F (43°C)~~ that is heated or blended with hot water to a temperature that is not greater than 120°F (49°C).

Internal ID: 1490

P58-18 Part II

IRC: R202

Proponent: Tim Keane, representing self (timke@verizon.net)

2018 International Residential Code

Revise as follows:

[MP] HOT WATER. Water at a temperature greater than ~~or equal to~~ 110°F (43°C) ~~120°F (49°C)~~.

Reason:

The purpose of this code change proposal is to address the requirement to provide tempered water to public hand-washing facilities, to change the temperature of water delivered to public hand-washing facilities to a maximum of 120°F and to enable the use of either cold water or tempered water at public hand-washing facilities.

Most of the reasons supporting this proposal are discussed below. In addition, we are proposing that where tempered water is supplied to public hand-washing facilities its temperature can be controlled by either a local mixing valve (ASSE1070) or by a master mixing valve (ASSE 1017), depending on the configuration of the hot water distribution system.

What follows is the reason statement that supports several code change proposals. There is one reason statement for these proposals because the topics are interrelated and a comprehensive discussion is most likely to result in the best outcome for protecting the public's health and safety.

Health and safety for public hand washing needs to include 1) scald prevention, 2) hand washing efficacy and 3) minimizing the risk of pathogen growth in the building's water distribution system.

We do not want the temperature of the water at public sinks to be too hot. We want the temperature of the water to be comfortable for the users of public sinks so that people will scrub their hands long enough to get them clean. We want to reduce the likelihood that pathogens will grow in the water distribution system. And, we would like to accomplish all of these health and safety functions in the most cost effective and sustainable manner possible.

At present, we believe that there are a few provisions in the IPC that inadvertently create a public health risk. Changing the temperature limits in this definition is one part of resolving this problem.

When the provisions in the current definitions and the related sections were first codified, Legionella was not a significant concern to public health; many items known today were unknown then. Now Legionella in building water systems has become a major concern for public health with the incidence of Legionnaires' disease growing by 500% from 0.4 cases per 100,000 people in 2000 to 2.0 cases per 100,000 people in 2015.¹

At the time these same provisions were codified, it used be thought that warm water was necessary for effective hand cleaning to control the spread of germs (bacteria). Science has since proven that the temperature of the water used for handwashing does not impact the efficacy of removing bacteria at all.^{2, 3, 4} While each of these three papers are very clear the CDC sums it up best with "The temperature of the water does not appear to affect microbe removal; however, warmer water may cause more skin irritation and is more environmentally costly"⁴ The most important variables for removing bacteria from ones hands are scrubbing and the use of soap. Neither of these criteria is within the purview of a building code.

When scald prevention was discussed as part of codifying these same provisions, the unintended consequences of lower water temperature on waterborne pathogen growth was not known. Accordingly temperature of 140°F originally proposed for scald control in home hot water heaters was lowered to 130°F and finally a recommendation of 120°F was made because if 140°F was OK it was thought that adding a huge safety margin would only be better, we now know that huge safety margin had serious and significant unintended consequences. A temperature of 120°F is considered an abundantly safe scald limit. However, setting water heaters this low results in much of the hot water distribution system being at temperatures that ideal for growing pathogens.

Since 1998 OSHA guidelines have stated that hot water should be stored at 140F and delivered at a temperature greater than 120F. In 2009, the CDC published a study documenting scalding cases resulting in hospital visits by the elderly from 2001-2006. The elderly are the highest risk population for Legionnaires' disease and one of the highest risk for scalding. They found that more than 80% of the scalding cases were due to cooking activities in the kitchen. Less than 3% (220 out of 8,620 cases) were plumbing related.¹³

We believe that it is time to use our current knowledge of these interrelated elements to improve health and safety by revising the a few of the temperature related provisions in the 2018 IPC and the 2018 IRC-P

In both the IPC and the IRC, hot water is required to be supplied to plumbing fixtures and plumbing appliances intended

for bathing, washing, or culinary purposes. The 2018 IPC and IRC-P have two different maximum temperature thresholds, which some say are for scald prevention. The temperature at public hand washing sinks (lavatories), is limited to 110°F. With the exception of bidets and emergency fixtures, which are also limited to 110°F, all other fixtures are limited to 120°F. Please see the table below.

Water Temperature Provisions in the 2018 IPC and IRC-P

Fixture	Maximum Temperature	Section
Bidet	110F (43C)	IPC 408.3 IRC P2721.2
Emergency showers and eyewash stations	110F (43C)	IPC 411.1*
Individual shower valve	120F (49C)	IPC 412.3 IRC P2708.4
Multiple (gang) showers	120F (49C)	IPC 412.4
Temperature-actuated, flow-reduction devices for individual fixture fittings	120F (49C)	IPC 412.7
Public lavatories	110F (43C)	IPC 419.5
Bath tub and whirlpool tub	120F (49C)	IPC 412.5 IRC 2713.3
Head shampoo sink faucet	120F (49C)	IPC 412.10
Footbaths and pedicure baths	120F (49C)	IPC 423.3

* The maximum temperature is not shown in this IPC section, but rather in the referenced standard. This standard also has a minimum acceptable temperature of 60F for emergency fixtures. This lower number might be useful guidance for jurisdictions with cold incoming water temperatures that want to raise the temperature of cold water for hand washing during the winter months where only cold water is supplied to public lavatory faucets.

Bidets, emergency showers and eyewash stations and public lavatories are required to have tempered water supplied through a water temperature limiting device that conforms to the appropriate ASSE, ANSI or CSA standard. The upper limit of 110°F makes sense for bidets and emergency showers. It does not make sense for hand washing at public lavatories.

If 120°F is a safe temperature for showering, bathing, head shampooing, tubs, it is equally safe for hand washing at either public or private lavatory faucets. It does not make sense that the temperature is lower for hand washing than for tub bathing. If the water temperature rises quickly to an uncomfortably hot and unsafe number it is much easier to remove ones hands from the water coming out of the faucet than it is to get out of a bathtub or to get out of the way in a shower. There is no need to have a lower temperature supplied for hand washing than for showering or bathing. In fact this public lavatory temperature code is derived from ASHRAE 90.1 energy saving code, not safety.

In our research into this issue, we found that the 110°F temperature limitation for hand washing at public lavatories comes from an energy code, ASHRAE 90.1 (1989)⁵ “Energy Standard for Buildings Except Low-Rise Residential Buildings.” Section 11.4.5.2 presents the provisions for lavatories in public facility restrooms (such as those in service stations, airports, train terminals, and convention halls). These include the requirement for low flow rates (the document preceded the 1990’s era EPACT rules concerning public lavatory faucet flow rates) and for limiting the temperature to a maximum of 110°F.

In the very high use public toilets detailed in 90.1 (1989) the sinks are used many times per hour, and the combination of low temperature and low flow does not dramatically increase the health risks from waterborne pathogens; the very high turnover rates of the water in the piping brings in new disinfectant.

However, many toilet facilities currently classified as “public” are only used sporadically. The combination of low hot water temperature, low flow rate and infrequent usage, results in a very low turnover rate which in turn means that new disinfectant enters the piping very infrequently. This condition not only provides a localized incubation chamber for Legionella but once grown can result in contaminating the rest of the hot water system.

While the idea of establishing 85-110°F as a safe range for public hand washing seemed like a good idea at the time, it turns out this range is ideal for the growth of pathogens in the building’s water distribution system. Pathogens that affect humans grow in temperatures that are found in our bodies: 85-110°F. For example, Legionella reproduces at the highest rates in the range of 85-110°F. Legionnaires’ disease, caused by Legionella growth in building water systems has become a major public health concern.

Adding to the risk due to temperature is the complexity of the internal components of the mixing valves and the lack of maintenance these valves typically receive. Such maintenance is relatively time consuming and costly and is often ignored. By way of comparison, Australian codes for health and safety purposes require these local mixing valves to be disassembled and disinfected annually^{6, 7, 8}

Conclusions and Recommendations:

If 120°F is safe enough to protect against scalding for bathing, it is safe enough for public hand washing. If this temperature is safe enough for Health Care Occupancies (IPC Section 609.3), it is safe enough for the other occupancies covered by the IPC.

Maintaining temperatures in the range of 85-110°F that is currently required in Section 419.5 is unsafe because it provides ideal conditions for the growth of pathogens, bacteria dangerous to humans. All Legionella guidelines including OSHA 1998⁹, ASHRAE 2000¹⁰, CDC 2003¹¹, and CDC 2016¹² recommend maintaining hot water temperatures at fixtures and in hot water return lines at or above 120°F.

It is not necessary to specify the temperature range for supplying water for hand washing in public lavatories, only the maximum temperature to prevent scalding.

We recommend that the maximum safe temperature for the discharge of hot water into public hand washing sinks be raised to 120°F.

We recommend moving the break point between tempered and hot water from 110°F to 120°F.

We recommend enabling the use of cold water only, or tempered water, or both at public hand washing sinks.

Bibliography:

US Centers for Disease Control (CDC) Atlanta, GA Chart titled, "Legionnaires' Disease is on the Rise 2000-2015*" National Notifiable Diseases Surveillance System <https://www.cdc.gov/legionella/downloads/fs-legionella-clinicians.pdf>

Quantifying the Effects of Water Temperature, Soap Volume, Lather Time, and Antimicrobial Soap as Variables in the Removal of Escherichia coli ATCC 11229 from Hands Journal of Food Protection June 2017 Dane A. Jensen,¹ David R. Macinga,² David J. Shumaker,² Roberto Bellino,² James W. Arbogast,² and Donald W. Schaffner¹ <http://foodprotection.com/doi/full/10.4315/0362-028X.JFP-16-370?code=fopr-site>

Above was in an article titled Cool Water as Effective as Hot for Removing Germs During Handwashing Infection Control Today May 30 2017

The environmental cost of misinformation: why the recommendation to use elevated temperatures for handwashing is problematic International Journal of Consumer Studies Volume 37, Issue 4 July 2013 Amanda R. Carrico, Micajah Spoden, Kenneth A. Wallston, Michael P. Vandenberg <http://onlinelibrary.wiley.com/doi/10.1111/ijcs.12012/abstract>

Show Me the Science - How to Wash Your Hands CDC Website <https://www.cdc.gov/handwashing/show-me-the-science-handwashing.html>

ASHRAE 90.1 (1989) "Energy Standard for Buildings Except Low-Rise Residential Buildings"

Guidelines for the Control of Legionella in Manufactured Water Systems in South Australia, 2008 revised 2013 <http://www.sahealth.sa.gov.au/wps/wcm/connect/d2f047804755f77e91f5d322c3ec38c5/LegionellaGuidelines+revised+2+MOD=AJPERES>

Department of Health & Human Services Victoria Australia Sept 2011 "Risk management plan for Legionella Control in health and aged care facilities" <https://www2.health.vic.gov.au/about/publications/policiesandguidelines/risk-management-plan-for-legionella-control-in-health-and-aged-care-facilities>

Australian Standard. Water supply. Valves for the control of heated water supply temperatures Part 3: Requirements for field-testing, maintenance or replacement of thermostatic mixing valves, tempering valves and end-of-line temperature control devices <https://www.saiglobal.com/PDFTemp/Previews/OSH/as/as4000/4000/40323.pdf>

Occupational Safety and Health Administration (OSHA) "Technical Manual Section III: Chapter 7 Legionnaires' Disease" 1998 https://www.osha.gov/dts/osta/otm/otm_iii/otm_iii_7.html

American Society of Heating, Refrigeration and Air-Conditioning Engineers, Inc. (ASHRAE) Guideline 12 "Minimizing the Risk of Legionellosis Associated with Building Water Systems" 2000

Centers for Disease Control and Prevention (CDC) Guidelines for Environmental Infection Control in Health-Care Facilities 2003 <https://www.cdc.gov/infectioncontrol/pdf/guidelines/environmental-guidelines.pdf>

Centers for Disease Control and Prevention (CDC) Developing a Water Management Program to Reduce Legionella Growth & Spread in Buildings | <https://www.cdc.gov/legionella/downloads/toolkit.pdf>

Centers for Disease Control and Prevention (CDC) MMWR Weekly September 18, 2009 / 58(36);993-996 "Nonfatal Scald-Related Burns Among Adults Aged ≥65 Years --- United States, 2001—2006" <https://www.cdc.gov/mmwr/preview/mmwrhtml/mm5836a1.htm>

Cost Impact

The code change proposal will decrease the cost of construction.

This proposal enables the use of cold water, tempered water, or both to public hand-washing facilities. If only cold water is supplied, it will decrease construction costs by eliminating the installation of a hot water distribution system to these faucets and by eliminating the installation of the associated ASSE 1070 mixing valves, reducing or eliminating the water heater for this hot water and eliminating the mechanical space used by this piping and equipment. It will also eliminate the costs of operations and maintenance by reducing expenditures on hot water and on the maintenance of the mixing valves.

In places where city cold water is above 60°F year round, allowing only cold water to be supplied to public lavatories will eliminate much if not all the hot water piping and associated equipment in many buildings.

By virtue of raising the allowable maximum temperature to 120F it will now be possible to use a master-mixing valve (ASSE 1017) for temperature control instead of installing ASSE 1070 valves at every faucet. One valve costs less than many valves. Having fewer valves also dramatically reduces operating and maintenance costs.

Internal ID: 1494

P59-18

IPC: 419.5, Chapter 15

Proponent: Julius Ballanco, JB Engineering and Code Consulting, P.C., representing Bradley Corporation (JBENGINEER@aol.com)

2018 International Plumbing Code

Revise as follows:

419.5 Tempered water for public hand-washing facilities. *Tempered water* shall be delivered from lavatories and group wash fixtures located in public toilet facilities provided for customers, patrons and visitors. *Tempered water* shall be delivered through an *approved* water-temperature limiting device that conforms to ASSE 1070/ASME A112.1070/CSA B125.70 or CSA B125.3 or from a water heater complying with ASSE 1082 or ASSE 1084.

Add new standard(s) follows:

ASSE

ASSE International
18927 Hickory Creek Drive, Suite
220
Mokena IL 60448

1084-2018:

Performance Requirements for Water Heaters used as Temperature Limiting Devices

1082-2018:

Performance Requirements for Water Heaters Used as Temperature Control Devices for Hot Water Distribution Systems.

Reason:

There are two new standards for water heaters, ASSE 1082 and ASSE 1084. These water heaters are equivalent to ASSE 1017 and ASSE 1070 respectively. As such, they have the capability of providing an equivalent level of performance as the currently listed water-temperature limiting device.

Water heaters complying with either one of these standards can provide tempered water within a range of a few degrees depending on the flow rate. The temperature range is similar to the allowable temperature range for an ASSE 1070/ASME A112.1070/CSA B125.70 device.

Cost Impact

The code change proposal will decrease the cost of construction .

This change could lower the cost by the allowance of a water heater without the need for an additional valve.

Analysis: A review of the standards proposed for inclusion in the code, ASSE 1084-2018 and ASSE1082-2018, with regard to the ICC criteria for referenced standards (Section 3.6 of CP#28) will be posted on the ICC website on or before April 2, 2018.

Internal ID: 1128

P60-18

IPC: 419.5, Chapter 15

Proponent: Julius Ballanco, JB Engineering and Code Consulting, P.C., representing Bradley Corporation (JBEngineer@aol.com)

2018 International Plumbing Code

Revise as follows:

419.5 Tempered water for public hand-washing facilities. *Tempered water* shall be delivered from lavatories and group wash fixtures located in public toilet facilities provided for customers, patrons and visitors. ~~Tempered~~ The tempered water shall be ~~delivered through an approved water temperature limiting device that conforms to~~ controlled by one of the following:

1. A temperature limiting device conforming to either ASSE 1070/ASME A112.1070/CSA B125.70 or CSA B125.3.
2. A thermostatic mixing valve conforming to ASSE 1017.
3. A water heater conforming to ASSE 1082.
4. A water heater conforming to ASSE 1084.
5. A temperature actuated flow reduction device conforming to ASSE 1062.

Add new standard(s) follows:

ASSE

ASSE International
18927 Hickory Creek Drive, Suite
220
Mokena IL 60448

1084-2018:

Performance Requirements for Water Heaters used as Temperature Limiting Devices

1082-2018:

Performance Requirements for Water Heaters Used as Temperature Control Devices for Hot Water Distribution Systems.

Reason:

The requirements for public lavatories is out of date based on the changes made to the standard. Previously, ASSE 1070 was considered a thermostatic mixing valve standard with safety features. The standard was revised to be a safety standard without performance requirements for thermostatic mixing. Some valves are adjustable, while others are not.

The requirement for tempered water for public lavatories is a comfort requirement as well as a scald prevention requirement. However, comfort overrides the safety requirement since tempered water is limited to a maximum temperature of 110° F. Scalding temperatures are in excess of this temperature. Other viable means of tempering water to 110° F or less are an ASSE 1017 valve or a water heater meeting one of the two new standards.

The two new standard for water heaters are ASSE 1082 and ASSE 1084. These water heaters are equivalent to ASSE 1017 and ASSE 1070 respectively. As such, they have the capability of providing an equivalent level of performance as the corresponding mixing valve.

The last device listed is a TAFR complying with ASSE 1062. Section 412.7 already permits the use of these devices for controlling the water temperature discharging from a faucet. Hence, the identification of the standard in this section complements the requirements in Section 412.7.

Cost Impact

The code change proposal will decrease the cost of construction .

The availability of more options to achieve code compliance usually results in lower construction costs.

Analysis: A review of the standards proposed for inclusion in the code, ASSE 1084-2018 and ASSE1082-2018, with regard to the ICC criteria for referenced standards (Section 3.6 of CP#28) will be posted on the ICC website on or before April 2, 2018.

P61-18

IPC: 419.5, Chapter 15

Proponent: Misty Guard, representing Bradley Corporation (Misty.Guard@bradleycorp.com)

2018 International Plumbing Code

Revise as follows:

419.5 Tempered water for public hand-washing facilities. *Tempered water* shall be delivered from lavatories and group wash fixtures located in public toilet facilities provided for customers, patrons and visitors. *Tempered water* shall be delivered through an *approved* water-temperature limiting device that conforms to ASSE 1070/ASME A112.1070/CSA B125.70 or CSA B125.3 or from a water heater complying with ASSE 1082 or ASSE 1084.

Add new standard(s) follows:

ASSE

ASSE International
18927 Hickory Creek Drive, Suite
220
Mokena IL 60448

1084-2018:

Performance Requirements for Water Heaters used as Temperature Limiting Devices

1082-2018:

Performance Requirements for Water Heaters Used as Temperature Control Devices for Hot Water Distribution Systems.

Reason:

There are two new standards for water heaters, ASSE 1082 and ASSE 1084. These water heaters are equivalent to ASSE 1017 and ASSE 1070 respectively. As such, they have the capability of providing an equivalent level of performance as the currently listed water-temperature limiting device.

Water heaters complying with either one of these standards can provide tempered water within a range of a few degrees depending on the flow rate. The temperature range is similar to the allowable temperature range for an ASSE 1070/ASME A112.1070/CSA B125.70 device.

Cost Impact

The code change proposal will not increase or decrease the cost of construction .

There is no cost associated with this change since the code change will merely provide other options for complying with the current requirements. There are no new mandatory requirements being added.

Analysis: A review of the standards proposed for inclusion in the code, ASSE 1084-2018 and ASSE1082-2018, with regard to the ICC criteria for referenced standards (Section 3.6 of CP#28) will be posted on the ICC website on or before April 2, 2018.

Internal ID: 2251

P62-18

IPC: 421.1

Proponent: Pennie Feehan, representing Plumbing, Mechanical, and Fuel Gas Code Action Committee (PMGCAC@iccsafe.org)

2018 International Plumbing Code

Revise as follows:

421.1 Approval. Prefabricated showers and shower compartments shall conform to ASME A112.19.1/CSA B45.2, ASME A112.19.2/CSA B45.1, ASME A112.19.3/CSA B45.4 or CSA B45.5/IAPMO Z124. Shower valves for individual showers shall conform to the requirements of Section 412.3.

Reason:

The current standards are only for ceramic and plastic type plumbing fixtures. Including standards for enameled cast iron, enameled steel plumbing fixtures and stainless steel fixtures provides for more flexibility in fixture selection. The added standards are already in the IPC.

This proposal is submitted by the ICC Plumbing/Mechanical/Gas Code Action Committee (PMG CAC). The PMG CAC was established by the ICC Board of Directors to pursue opportunities to improve and enhance the International Codes or portions thereof that were under the purview of the PMG CAC. In 2017 the PMG CAC held one face-to-face meeting and 11 conference call meetings. Numerous interested parties attended the committee meetings and offered their input.

Cost Impact

The code change proposal will not increase or decrease the cost of construction .

The addition of the standards provides more flexibility in choice of fixtures. Enameled cast iron, enameled steel and stainless steel plumbing fixtures and stainless steel fixtures are not required to be installed; they are a choice that the designer can make.

Internal ID: 499

P63-18 Part I

IPC: 421.3.1 (New)

Proponent: Angel Guzman Rodriguez, ASME, representing The American Society of Mechanical Engineers (ASME)

THIS IS A 2 PART CODE CHANGE PROPOSAL. PART I WILL BE HEARD BY THE IPC COMMITTEE. PART II WILL BE HEARD BY THE IRC-PLUMBING COMMITTEE. SEE THE TENTATIVE HEARING ORDERS FOR THESE COMMITTEES.

2018 International Plumbing Code

Add new text as follows:

421.3.1 Waste Fittings. Waste fittings shall conform to ASME A112.18.2/CSA B125.2.

Internal ID: 1407

P63-18 Part II

IRC: P2708.2.1 (New)

Proponent: Angel Guzman Rodriguez, ASME, representing The American Society of Mechanical Engineers (ASME)

2018 International Residential Code

Add new text as follows:

P2708.2.1 Waste Fittings. Waste fittings shall conform to ASME A112.18.2/CSA B125.2

Reason:

Section 421.3 discusses the waste outlet requirements for showers but there is no mention of waste fittings. Waste fittings are only mentioned in 412.1.2 for faucets or 412 for floor and trench drain types. The latest version of ASME A112.18.2/CSA B125.2 contains specific requirements for typical shower drains and also linear type drains which are different from trench type. This standard also includes requirements for built up shower drain systems which are normally used in field fabricated shower systems.

Cost Impact

The code change proposal will not increase or decrease the cost of construction .

This proposal only identifies the standard that the industry is already making these waste fittings comply with and be certified to. Thus, there will be no impact to material (or labor) cost because of this added requirement.

Internal ID: 1453

P64-18

IPC: 421.5.2

Proponent: James Richardson Jr, representing City of Columbus Ohio (jarichardson@columbus.gov); Robert Schutz, representing City of Columbus, OH (RJSchutz@columbus.gov)

2018 International Plumbing Code

Revise as follows:

421.5.2 Shower ~~lining~~ linings. Floors under shower compartments, except where prefabricated receptors have been provided, shall be lined and made water tight utilizing material complying with Sections 421.5.2.1 through 421.5.2.6. Such liners shall turn up on all sides not less than 2 inches (51 mm) above the finished threshold level. Liners shall be recessed and fastened to an *approved* backing so as not to occupy the space required for wall covering, and shall not be nailed or perforated at any point less than 1 inch (25 mm) above the finished threshold. Liners shall be pitched one-fourth unit vertical in 12 units horizontal (2-percent slope) and shall be sloped toward the fixture drains and be securely fastened to the waste outlet at the seepage entrance, making a water-tight joint between the liner and the outlet. For showers that are designed with a zero height threshold, a trench drain shall be provided that runs 2 inches beyond the full width of the shower compartment opening on both sides. The trench drain shall have a flashing clamp and the shower liner material shall be securely fastened to the waste outlet at the seepage entrance, making a water-tight joint between the liner and the outlet. The shower liner shall also be required to extend 2 inches above the floor level and 1 inch beyond the edges of the trench drain. If for some reason the trench drain cannot be accommodated, the entire room the shower is located in shall be considered part of the shower compartment and provided with a liner for the entire floor surface.

The completed liner shall be tested in accordance with Section 312.9.

Exceptions:

1. Floor surfaces under shower heads provided for rinsing laid directly on the ground are not required to comply with this section.
2. Where a sheet-applied, load-bearing, bonded, waterproof membrane is installed as the shower lining, the membrane shall not be required to be recessed.

Reason:

The plumbing code has not yet dealt with site built zero height threshold showers. These continue to be a problem for jurisdictions since the code provides no direction or parameters for how these should be constructed. We have seen installations end up causing substantial damage to a structure due to water migration between the floor covering and the sub floor. This proposal provides two possibilities which should result in adequate protection for the structure.

Cost Impact

The code change proposal will increase the cost of construction .

There will be the added material and labor cost of a trench drain or the added material and labor cost for a liner for the entire floor area of the room with the zero threshold shower.

Internal ID: 2207

P65-18

IPC: 423.3, Chapter 15

Proponent: Julius Ballanco, JB Engineering and Code Consulting, P.C., representing Bradley Corporation (JBEngineer@aol.com)

2018 International Plumbing Code

Revise as follows:

423.3 Footbaths and pedicure baths. The water supplied to specialty plumbing fixtures, such as pedicure chairs having an integral foot bathtub and footbaths, shall be limited to not greater than 120°F (49°C) ~~by a~~. The water - temperature-limiting device that conforms temperature shall be regulated by one of the following:

1. A limiting device conforming to ASSE 1070/ASME A112.1070/CSA B125.70 or CSA B125.3.
2. A thermostatic mixing valve conforming to ASSE 1017.
3. A water heater conforming to ASSE 1082.
4. A water heater conforming to ASSE 1084.
5. A temperature actuated flow reduction device conforming to ASSE 1062.

Add new standard(s) follows:

ASSE

ASSE International
18927 Hickory Creek Drive, Suite
220
Mokena IL 60448

1082-2018:

Water Heaters Used as Temperature Control Devices for Hot Water Distribution Systems.

1084-2018:

Performance Requirements for Water Heaters used as Temperature Limiting Devices

Reason:

The requirement for regulating the maximum temperature of water for pedicure chairs having an integral foot bathtub, footbaths, and head shampoo sinks is a scald prevention requirement. The current code allows the use of a device complying with ASSE 1070/ASME A112.1070/CSA B125.70 or CSA B125.3.

Section 412.7 already permits the use of a TARF complying with ASSE 1062 for controlling the water temperature discharging from a faucet. Hence, the identification of the standard in this section complements the requirements in Section 412.7.

A thermostatic mixing valve is an effective method of regulating the maximum temperature. The temperature is maintained within a few degrees depending on the flow rate. Scalding temperatures are in excess of this temperature. Other viable means of maintaining the water temperature to a maximum of 120° F are water heater meeting one of the two new standards.

The two new standard for water heaters are ASSE 1082 and ASSE 1084. These water heaters are equivalent to ASSE 1017 and ASSE 1070 respectively. As such, they have the capability of providing an equivalent level of performance as the corresponding mixing valve.

Cost Impact

The code change proposal will decrease the cost of construction .

The availability of more options to achieve code compliance usually results in lower construction costs.

Analysis: A review of the standard proposed for inclusion in the code, ASSE 1082-2018 and ASSE 1084-2018, with regard to the ICC criteria for referenced standards (Section 3.6 of CP#28) will be posted on the ICC website on or before April 2, 2018.

Internal ID: 1161

P66-18

IPC: 423.3, Chapter 15

Proponent: Misty Guard, representing Bradley Corporation (Misty.Guard@bradleycorp.com)

2018 International Plumbing Code

Revise as follows:

423.3 Footbaths and pedicure baths. The water supplied to specialty plumbing fixtures, such as pedicure chairs having an integral foot bathtub and footbaths, shall be limited to not greater than 120°F (49°C) by a water-temperature-limiting device that conforms to ASSE 1070/ASME A112.1070/CSA B125.70 or CSA B125.3 or from a water heater complying with ASSE 1082 or ASSE 1084.

Add new standard(s) follows:

ASSE

ASSE International
18927 Hickory Creek Drive, Suite
220
Mokena IL 60448

1084-2018:

Performance Requirements for Water Heaters used as Temperature Limiting Devices

1082-2018:

Performance Requirements for Water Heaters Used as Temperature Control Devices for Hot Water Distribution Systems.

Reason:

There are two new standards for water heaters, ASSE 1082 and ASSE 1084. These water heaters are equivalent to ASSE 1017 and ASSE 1070 respectively. As such, they have the capability of providing an equivalent level of performance as the currently listed water-temperature limiting device.

Water heaters complying with either one of these standards can provide tempered water within a range of a few degrees depending on the flow rate. The temperature range is similar to the allowable temperature range for an ASSE 1070/ASME A112.1070/CSA B125.70 device.

Cost Impact

The code change proposal will not increase or decrease the cost of construction .

There is no cost associated with this change since the code change will merely provide other options for complying with the current requirements. There are no new mandatory requirements being added.

Analysis: A review of the standards proposed for inclusion in the code, ASSE 1084-2018 and ASSE1082-2018, with regard to the ICC criteria for referenced standards (Section 3.6 of CP#28) will be posted on the ICC website on or before April 2, 2018.

Internal ID: 2253

P67-18

IPC: 423.3

Proponent: William Chapin, Professional Code Consulting, LLC, representing Professional Code Consulting, LLC (bill@profcc.us)

2018 International Plumbing Code

Revise as follows:

423.3 Footbaths and pedicure baths. The water supplied to specialty plumbing fixtures, such as pedicure chairs having an integral foot bathtub and footbaths, shall be limited to not greater than 120°F (49°C) by a water-temperature-limiting device that conforms to ASSE 1070/ASME A112.1070/CSA B125.70 ~~or CSA B125.3.~~

Reason:

In June of 2017, the CSA B125 Committee completed the project that removed the automatic compensating valve requirements from CSA B125.3. The reason for this was the publication of harmonized ASSE 1070/ASME A112.1070/CSA B125.70 standard.

Cost Impact

The code change proposal will not increase or decrease the cost of construction .

Proposal only removes a referenced standard from the code section.

Internal ID: 2252

P68-18

IPC: 202, 425.1, 425.1.1 (New), 425.1.2 (New), 425.1.3 (New)

Proponent: Pennie Feehan, representing Plumbing, Mechanical, and Fuel Gas Code Action Committee (PMGCAC@iccsafe.org)

2018 International Plumbing Code

Revise as follows:

425.1 Approval. Water closets shall conform to the water consumption requirements of Section 604.4 and shall conform to ASME A112.19.2/CSA B45.1, ASME A112.19.3/CSA B45.4 or CSA B45.5/IAPMO Z124. ~~Water closets shall conform to the hydraulic performance requirements of ASME A112.19.2/CSA B45.1. Water closet tanks shall conform to ASME A112.19.2/CSA B45.1, ASME A112.19.3/CSA B45.4 or CSA B45.5/IAPMO Z124. Electro-hydraulic water closets shall comply with ASME A112.19.2/CSA B45.1. Water closets equipped with a dual flushing device shall comply with ASME A112.19.14.~~

Add new text as follows:

425.1.1 Hydraulic performance. Water closets shall conform to the hydraulic performance requirements of ASME A112.19.2/CSA B45.1.

425.1.2 Water closet tanks. Water closet tanks shall conform to ASME A112.19.2/CSA B45.1, ASME A112.19.3/CSA B45.4 or CSA B45.5/IAPMO Z124.

425.1.3 Dual flush water closets. Water closets equipped with a dual flushing device shall comply with ASME A112.19.14.

Add new definition as follows:

DUAL FLUSHING DEVICE. A feature that allows the user to flush a water closet with either a reduced or full volume of water depending upon bowl contents.

Reason:

This proposal revises Section 425.1 so that it is more user friendly. Adding specific requirements to the IPC will assist the end user to know which standards apply to what fixture. The definition for dual flushing device is being added as code does not have a definition. The definition is consistent with the definition found in ASME A112.19.14.

This proposal is submitted by the ICC Plumbing/Mechanical/Gas Code Action Committee (PMG CAC). The PMG CAC was established by the ICC Board of Directors to pursue opportunities to improve and enhance the International Codes or portions thereof that were under the purview of the PMG CAC. In 2017 the PMG CAC held one face-to-face meeting and 11 conference call meetings. Numerous interested parties attended the committee meetings and offered their input.

Cost Impact

The code change proposal will not increase or decrease the cost of construction .

This proposal is a clarification of existing requirements. No new materials or labor are required by this proposal thus, there is not a cost increase.

Internal ID: 502

P69-18

IPC: 501.2

Proponent: James Kendzel, American Supply Association, representing American Supply Association
(jkendzel@asa.net)

2018 International Plumbing Code

Revise as follows:

501.2 Water heater as space heater. Where a combination potable water heating and space heating system requires water for space heating at temperatures greater than 140°F (60°C), a master thermostatic mixing valve complying with ASSE 1017 shall be provided to limit the water supplied to the potable *hot water* distribution system to a temperature of 140°F (60°C) or less. The potability of the water shall be maintained throughout the system. Requirements for combination potable water heating and space heating systems shall be in accordance with the International Mechanical Code.

Reason:

There are requirements in the International Mechanical Code for combination water heating and space heating systems that are covered in the IMC and not covered in the IPC. The 2018 IMC provides a reference back to the IPC related to water heating and space heating systems and there should also be a link from the IPC back to the IMC.

Cost Impact

The code change proposal will not increase or decrease the cost of construction .

Proposed change is not substantive and does not change existing requirements.

Internal ID: 1350

P70-18

IPC: 501.2

Proponent: Ronald George, representing Self (Ron@Plumb-TechLLC.com)

2018 International Plumbing Code

Revise as follows:

501.2 Water heater as space heater. Where a combination potable water heating and space heating system requires water for space heating at temperatures greater than 140°F (60°C), a master thermostatic mixing valve complying with ASSE 1017 shall be provided to limit the water supplied to the potable *hot water* distribution system to a temperature of 140°F (60°C) or less. The potability of the water-water for the space heating system shall be maintained throughout the system, separated from the potable water system by use of a double wall heat exchanger.

Reason:

This code change still allows a single heating appliance to provide both the heating and domestic hot water for a building, however it requires a heat exchanger to separate the two fluid systems. This is because heating hot water systems can sit idle for up to 8 or 9 months per year in southern climates. This causes the water to sit stagnate for many months when the thermostat does not call for heat. This stagnant period is when bacteria grows in a biofilm to very high numbers until the thermostat calls for heat. Then the bacteria is pumped into the water heater where it is transmitted to people from showers and other aerosolizing fixtures. The potential for Legionellosis or Legionnaires' disease is very high. The control valve or zone circulating pump remains off and allows water treatment chemicals to dissipate and bacteria can growth to very high levels in an uncirculated heating circuit. In systems where they cycle the zone valve or circulating pump, it wastes energy and overheats the spaces during summer months. There are other issues that are outlined below.

Combined systems require someone very familiar with how both systems are supposed to operate to properly operate and maintain the system. Proper maintenance of the system can be a comfort or Legionella bacteria growth issue when the temperatures are low and a serious safety and scald issue when temperatures are high. A combined system is a hybrid system that utilizes a boiler or boilers to heat water for heating the building environment and it uses boiler water to heat the domestic hot water for bathing, washing and cleaning uses. There are two applications for these combined systems. One application is heating the building environment with heating hot water which generally needs to be at a very high temperature around 180F to 210F without using oversized heating coils. The other application is for bathing, showering and domestic hot water uses which generally use a lower temperature around 85F to 120F. If the water gets too hot, there are scalding dangers, so proper controls (thermostatic mixing valves) are very important for these types of systems. I have been investigating scald incidents with combined systems since the mid-1990s and I have seen a significant number of these combined systems involved in scald litigation cases because these systems are generally not designed, installed, operated or maintained properly. The following is a list of problems or pitfalls that I have found over the years that are related to combined heating hot water and domestic hot water systems.

Codes: There is very little code language on Combines heating hot water and domestic hot water systems. There are only two plumbing code sections in the model codes that mention these combined systems and they give important, but often overlooked requirements. One section calls for the piping and components in a combined system to be approved for use in potable water systems. The other code section calls for a thermostatic mixing valve if the system temperature exceeds 140 degrees Fahrenheit.

There are many more issues that need to be addressed to have a safe and properly designed system. If you can avoid these pitfalls you will have a much safer system:

Pitfall Number 1: Open System vs Closed System “Open systems” are systems with domestic hot water flowing from the city water supply through the heating hot water system components such as pumps, control valves and heating coils. Open systems introduce a lot of oxygen and minerals into the heating coil of the boiler and can cause corrosion and scale build-up issues on heating surfaces. Open systems often have scale build-up on the boiler heating surfaces in hard water areas. High Flue gas temperatures are a sign of scale build-up which minimizes heat transfer into the water and therefore the flue temperatures rise. “Closed Systems” are systems with a double wall heat exchanger separating the fluid of the heating hot water system and the domestic hot water. The boiler loop can be chemically treated and mineral build-up on heating surfaces is minimized. Closed loop systems generally require a double wall heat exchanger when boiler chemicals are used. Open systems provide a significant challenge because the fluid in the system must be potable water and it is difficult to circulate domestic hot water through many hydronic components without having scale, corrosion, build-up of air pockets and oxidation problems. Most hydronic systems have pumps, valves, coils and components that are not approved for drinking water service. Closed systems allow the heating

hot water to be chemically treated to prevent corrosion and scale build-up on heating surfaces. Closed hydronic heating systems are the preferred type of combined systems because it eliminates a lot of opportunities for systems problems. There are water heaters with hot water coils in the tank that can be used for this application or a plate and frame or shell and tube heat exchanger can be used for this application. Open systems often see corrosion problems in the components that are not compatible for domestic water systems.

Pitfall Number 2: System Operating Temperatures The next challenge is with the system operating temperatures.

Heating hot water systems are generally designed to operate between 180 degrees Fahrenheit and 210 degrees Fahrenheit. Domestic hot water systems are designed to operate between 85 degrees Fahrenheit for the lowest temperature of tempered water to 140 degrees Fahrenheit the highest hot water temperature for kitchens or laundries. "Tempered Water" is water having a temperature range between 85°F (29°C) and 110°F (43°C). "Hot Water" is water at a temperature greater than or equal to 110°F (43°C) and generally domestic hot water for bathing and showering is limited to a maximum of 120 degrees Fahrenheit in code language related to showers and bathtub facilities. Domestic hot water for dishwashing and laundries can be higher. Generally, domestic hot water systems operate at a maximum of 140 degrees Fahrenheit and heating hot water Systems operate best around 190 to 200 degrees Fahrenheit. If the combined-open heating hot water system is set to 120 degrees F the building will be cold in winter months because there will not be enough heat coming out of the heating units. If the system temperature is set to a higher temperature to satisfy the heating coils or baseboard heater requirements then there is a significant scald risk on the domestic hot water side of the system unless thermostatic mixing valves are used to limit hot water temperatures.

Pitfall Number 3 - Not including all of the required components in the combined systems A combined system has many components that are required for it to operate properly. If all of the components are not installed in the proper location, then the system will experience problems. These components include but are not limited to: The boiler, and expansion tank, isolation valves, unions, dielectric waterways, circulating pumps, air eliminators or air vents, control valves, relief valves, balancing valves, heating coils, fin tube radiators, thermostats, pressure gauges, temperature gauges, flushing connections, plumbing fixtures, drains, etc. All of these components must work in concert and be designed to work together as a system. If any one or several of the components are not installed, or if they are undersized, adjusted or installed improperly the problems and safety issues can occur.

Pitfall Number 4 - Seasonal Pumping and Pump Sizing In large centrally piped systems, when the winter heating season occurs all of the components in a combined heating hot water and domestic hot water system will require a simultaneous peak demand in the morning when it is showering time. So the circulating pump must be sized for the simultaneous peak heating and showering loads. During the winter months, it does not make sense to circulate a large quantity of water, so often I see a smaller circulating pump that is piped around the large circulating pump so it can be used in the winter months when the large circulators are not needed for building heating. This creates a large dead leg in the hot water piping where Legionellae bacteria can grow when the heating hot water pumps are shut down.

Pitfall Number 5 - Dead legs During the summer months the fan coil units and branches to baseboard heating units are shut off with a solenoid valve or the circulating pump on these branches does not run all summer long. It is not unusual for heating system to sit idle for over six months in southern climates. When the first call for heating is made there is usually a slug of brackish and foul tasting water that is high in debris, metals and bacteria content. Combined systems are by design creating very large dead legs which is a plumbing code violation in many plumbing codes. Controls on combined systems need to incorporate a periodic flushing of the zones by operating the solenoid valves and circulators on each zone on at least a bi-weekly basis if not more often. Chlorine dissipates in the domestic water over time and when heated. So dead legs are more susceptible to bacteria growth. In combined systems where a significant portion of the system is used seasonally for heating and the remainder of the system is being used year round for domestic hot water, combined systems are open systems that are susceptible to bacteria growth in stagnant sections of heating coil piping. Heating coils in the summer season are an area with huge potential for bacterial amplification when hydronic systems are coupled with domestic hot water systems and there is no physical barrier or heat exchanger to separate the fluids between the two systems.

Pitfall Number 6 - Peak load problems - Space heating and Shower loads simultaneously The early morning is the generally coldest time of day and it is also when guests at a hotel or an apartment building or condominium take their morning showers. Equipment, piping, pumps and valves must be sized to handle this simultaneous peak load. If the heating coils, pipe and pump equipment is not sized big enough the temperature of the space will drop and the shower water temperature will drop to an uncomfortable temperature. Either condition is likely to result in call and complaints about water temperatures or space temperatures being too low.

Pitfall Number 7 - Sizing Sizing problems can arise when engineers, owners or contractors try to be thrifty and save a few bucks by rounding down on their peak load calculations and downsizing pumps, piping, valves or coils. When this happens, you can bet the maintenance department phone will be ringing off the hook with complaints of spaces being too cold or not enough hot water for a shower during cold weather conditions. The maintenance men usually do what comes natural when they receive a call of not enough heat, they go to the boiler and turn the temperature up. When someone is scalded they always claim they never touched the thermostat. Turning up the temperature will not cause

problems for the heating coils, but it does significantly increase the risk of scalding if the maintenance man does not go around and re-adjust all of the maximum temperature limit stops in the showers and tub/shower valves. If the shower has an old two-handle or single handle non-compensating type shower valve that cannot compensate for changes in incoming temperature or pressure, then the risk of scalding is even greater. The best solution is to have a Thermostatic mixing valve on the hot water supply to the bathing and washing fixtures to limit the hot water to a safe temperature. If the hot water and heating water piping are still separated, and the system uses one boiler then a temperature actuated master thermostatic mixing valve conforming to ASSE 1017 or the appropriate CSA B-125 mixing valve can be located at the water heater to lower the hot water to a safe delivery temperature. If the combined system utilizes the same piping for heating hot water and domestic hot water then, a temperature limiting valve conforming to ASSE 1070 should be used in-line to mix cold water with hot water to provide a safe temperature of hot water for bathing or showering fixtures locally.

Pitfall Number 8 - Maintenance The main problem with a combined system is the system includes components and controls for two different mechanical trade disciplines. Often if there is a service call on one of these systems, the service technician may only be familiar with one system or the other. If the system was designed with a specific operating temperature it is not uncommon for a service tech familiar with only one system to set the temperature of the system to what he is accustomed to setting the temperature to. There are also many components in the system that one trade or the other may be unfamiliar with. For example in one case the owner called an HVAC technician to work on his combined system. The HVAC technician was used to setting hydronic system for building heating at 190 to 200 degrees Fahrenheit. The technician set the temperature to 190 degrees and later a woman was scalded when she got in her shower. The HVAC technician did not know he needed to reset the maximum temperature limit stop on all of the ASSE 1016 shower valves when he readjusted the boiler set point temperature. There are maintenance technicians that are trained and fully capable of working on combined systems, but they would need to have the design drawings, design operating temperatures and sequence of operations in order to properly maintain the system.

Pitfall Number 9 - Cast Iron Boiler on an Open System I have seen Cast iron boilers used on an open combined heating hot water and domestic hot water system. Cast iron boilers do not perform well with open systems because of the large quantities of water that introduces oxygen and minerals which cause rust stains, oxidation and fouling of the heating surfaces. This mistake does not take long to find because of the rust stains that appear in the sinks, bathtubs & showers. Cast iron boiler can work nicely, but they must have a separate closed loop of boiler water that is treated with corrosion inhibitors and other boiler chemicals as needed. The boiler water can then be piped to a coil in a hot water tank or to a heat exchanger to provide domestic hot water.

Pitfall Number 10 - No Hot Water Tank with Copper Fin Tube Boilers I have seen installation where someone thought they could save a few bucks by eliminating the storage tank and using the heating hot water main as the storage tank. This does not work in motels, hotels, apartment buildings and condos with large peak loads. In facilities like these there needs to be a stored volume of water ready for use in a dump load such as a morning shower period. Copper fin-tube boilers can only raise the temperature of the water 20 - 40 degrees Fahrenheit as the water flows through the boiler. If the water flows too slow, through the boiler, it will scale up and if the water flows too fast (in excess of five feet per second) the copper will erode away. These types of boilers work fine, they just need to have a storage tank for plumbing applications with a dump load. In heating applications the BTU input is matched to the heating load calculations and the system works fine. In a large domestic hot water or a combined heating hot water/domestic hot water system, copper fin-tube boilers should have an adjacent storage tank in order to work properly. If there is no storage tank, the system temperatures will drop off drastically during peak winter showering and building heating periods. The usual result is the maintenance personnel turn up the temperature and higher temperatures increase the risk of scalding.

Pitfall Number 11 - No Thermal Expansion Tank/Proper Thermal Expansion Tank Materials All heating hot water system and domestic hot water systems must have a thermal expansion tank. The thermal expansion tank should be sized for a system start-up from ambient to hot. Another problem I have encountered with these combined systems is usage of a hydronic expansion tank on a combined system. If the same water flows through the coils and to the plumbing fixtures, the system must have a thermal expansion tank rated for use in a potable water system. If the system has one boiler and two separate piping systems with a heat exchanger each piping system should have a thermal expansion tank.

Pitfall Number 12 - Scalding Injuries & Deaths Many designers, contractors and owners forget there are lives at stake when they design and build the combined heating hot water and domestic hot water systems. People have been scalded to death and people have been seriously injured when the systems are not designed, installed or maintained properly. This is more than just a savings on first-cost of an installation, it is a system that warrants serious attention because the public's safety is at stake. A properly sized and located thermostatic mixing valve conforming to ASSE 1017 or ASSE 1070 should be located in the combined system in accordance with the scoping requirements for each type of valve to prevent scalding. At shower locations an ASSE 1016 valve should be used and it should be properly set by the installer and/or the maintenance personnel to limit the maximum outlet temperature to 120 F or less.

Pitfall Number 13 - Litigation Combined systems are susceptible to problems. Problems can lead to injuries and

injuries can lead to litigation. If an open combined heating hot water and domestic hot water system cannot be properly maintained for the entire life of the system, don't design it, don't install it or don't request that it be installed because problems will arise. Combined systems require an extensive amount of work and oversight by a person with knowledge of both the heating water requirements and domestic hot water requirements to make sure the system works properly and to make sure someone does not get injured. You must document everything when working on a combined system because when someone gets injured, everyone will be named in the lawsuit.

Pitfall Number 14 - Code Requirements for Thermostatic Mixing Valves The 2009 International Plumbing Code has the following Language dealing with combined systems: 501.2 Water heater as space heater. Where a combination potable water heating and space heating system requires water for space heating at temperatures higher than 140°F (60°C), a master thermostatic mixing valve complying with ASSE 1017 shall be provided to limit the water supplied to the potable hot water distribution system to a temperature of 140°F (60°C) or less. The potability of the water shall be maintained throughout the system. The above code language limits the domestic hot water system to 140 degrees Fahrenheit, and in other code sections the temperature for showers and tub/shower combination units is limited to 120 degrees Fahrenheit. The 2009 International Plumbing code also has the following language addressing maximum water temperatures for instantaneous water heaters: 501.6 Water temperature control in piping from tankless heaters. The temperature of water from tankless water heaters shall be a maximum of 140°F (60°C) when intended for domestic uses. This provision shall not supersede the requirement for protective shower valves in accordance with Section 424.3.

Pitfall Number 15 - Engineered System vs Value Engineered systems I have seen where a value engineering option was offered by a contractor to combine the domestic hot water system with the heating hot water system. This was not a value to the owner and it was not engineered. During the evaluation process the owner decided to allow the contractor to combine the systems without the contractor providing engineered drawings. This decision gave the contractor the ability to use whatever he wanted to use since there were no engineered drawings. The owner got a system that did not work, and had black brackish water flushed out of the dead legs every fall when the heating system was turned on and the stagnant water was circulated through the domestic water piping. I submitted a report almost 200 pages long documenting the many problems in that system.

Pitfall Number 16 - Pipe Materials I have seen where a pipe material cost cutting option that was labeled as a value engineering option was given by a contractor. The option was accepted and the contractor simply eliminated the domestic hot water system and changed the hydronic system from black steel to galvanized steel piping. This was in a condominium building that had about 500 condos that sold in the neighborhood of 1 million dollars each. The galvanized pipe started to rust significantly within two years of service and rust stains were significant in all fixtures. The seasonal dead legs from the heating coils allowed rust barnacles to form until the first call for heat. When the flow in these dead leg branches would resume on the first call for heat in the fall it would flush rust, debris and iron oxide and stagnant water into the strainers of the control valves and into the domestic water system. Galvanized steel pipe should never be used on a domestic hot water system because domestic hot water in an open system connected to the city water main introduces a large quantity of oxygenated water into the system and causes rust. Oxygenated water will cause significant corrosion in ferrous metals such as black steel and galvanized pipe. All components of a combined system should be copper or another code approved non-ferrous material for domestic hot water service if they are in contact with the city water supply. Another thing I often see is iron valves installed in these combined systems. This is usually the result of a heating contractor installing or performing maintenance on the combined system and it is usually the result of the contractor not being familiar with the requirements in the code for all components to be all bronze and/or approved for domestic water use.

Pitfall Number 17 - Pumps When sizing pumps for a combined system there should be two separate systems. The closed system should have large circulating pumps designed for the heating hot water flows. The open system should have small circulator pumps to maintain hot water to the farthest fixture. It is also a good idea to split the load into two and use two smaller pumps to allow for some redundancy and allow for one pump to be maintained while the other is in service. It's a good idea to do this with the boilers also to provide some redundancy. The hydronic system should be a closed loop that can use large ductile iron bodied pumps. The domestic water system is an open system and should have an all bronze circulator. I have seen combined systems where it was an open system with large ductile iron pumps in the main piping before the boilers to provide an adequate flow of heating hot water in the winter months. Then because they did not want to run the large pumps just to maintain the domestic hot water temperature at the end of the system, a small bronze circulator was installed on a branch off of the main with check valves to prevent short circuiting the flow through the larger pumps. The problem with an open system is when the large pumps are shut down for sometimes over 6 months the pumps, and all hydronic circuits to heating coils and baseboard heaters become dead legs in the piping system. Dead legs are places where bacteria like Legionellae can grow and thrive. This is why there should be a separate closed piping circuit for the heating hot water system piping.

Pitfall Number 18 - Corrosion Ferrous piping in a domestic hot water system is not advisable. Although galvanized pipe is allowed by code for domestic hot water systems, it should never be used in a domestic hot water system if you intend for the building systems to last more than a couple of years. Hot water tends to accelerate corrosion in

galvanized piping systems. All domestic hot water piping should be copper or another approved non-ferrous material. Another problem with combined systems is the use of large cast iron and ductile iron hydronic heating circulating pumps that are installed in combined systems that were not approved for domestic water systems. I have seen galvanized steel pipes and even black steel pipe nipples used in domestic hot water systems. When the systems were first turned on in the fall large slugs of iron oxide laden water is forced into the domestic hot water distribution system. This generally results in sinks and bathtubs filled with black and orange rusty looking water until the entire system get flushed out significantly. The ferrous materials in the combined system typically lead to other problems with plugged strainers on control valves and other components. The iron oxide can also provide a surface for bacteria to grow.

Pitfall Number 19 - Corrosion inhibitors and other boiler water treatment chemicals I visited one building on the east coast where the combined system consisted of 8 inch galvanized water pipes. The galvanized pipes were corroding to the point where the hot water was very cloudy and orange. The building maintenance personnel chose to add an injection pump to inject chemicals into the domestic water main entering the building to raise the PH of the water and to intentionally build up a layer of scale inside the piping to minimize the amount of corrosion in the galvanized piping. The problem was the scale also formed on the heating surfaces and in the control valves causing them to fail. Upon inspection of the barrel of chemicals being injected into the water supply there were warning labels that stated the materials were toxic to humans. I reported this to the building owner to correct the situation immediately. This was another case of a heating contractor working on a plumbing system and not being familiar with plumbing code requirements. The solution he came up with would be a possible option for a hydronic system, but in a domestic water system that was a code violation and a health and safety issue.

Pitfall Number 20 - Loss of Both Systems When There is a Problem Another problem with combined systems is when there is a problem with a combined system that causes the system to shut down, both the domestic hot water system and the heating hot water system is out of service. If it is a boiler problem or another major problem the entire building could be without both systems for a long period of time. Combined system should have separate piping loops and redundant equipment to allow for some usage if one system or the other requires service.

Pitfall Number 21 - Legionellae Bacteria A research report in 1988 authored by Al Steele who was the president of the ASPE Research foundation at the time recommended storing domestic hot water between 135 degrees Fahrenheit and 140 degrees Fahrenheit to kill Legionellae bacteria and utilizing a thermostatic mixing valve to mix the hot water down to a safe delivery temperature below 120 degrees Fahrenheit to minimize scalding. The higher storage temperature around 140 degrees Fahrenheit was suggested because it is above the temperatures where Legionella bacteria can survive and multiply. With a storage temperature of 140 degrees Fahrenheit the Legionellae bacteria will die within 32 minutes.

Table -1 Legionellae Bacteria Growth and Disinfection Temperature Chart.

158 F and above F (70 C +): Legionellae Bacteria Disinfection range.

At 151 Degrees F (66 Degrees C): Legionellae die within 2 minutes.

At 140 Degrees F (60 Degrees C): Legionellae die within 32 minutes.

At 135 Degrees F (57.5 Degrees C) Legionellae die within 2 hours.

At 131 Degrees F (55 Degrees C): Legionellae die within 5 to 6 hours.

Above 122 Degrees F (50 Degrees C): They can survive but do not multiply.

95 to 115 Degrees F(35 to 46 Degrees C): Ideal Legionellae Bacteria growth range.

68 to 122 Degrees F (20 to 50 Degrees C): Legionellae Bacteria growth range.

Below 68 Degrees F (20 Degrees C): Legionellae can survive but are dormant.

The Legionellae bacteria cannot survive water temperatures above 131 degrees Fahrenheit (55 Degrees C) for more than five or six hours. The bacteria die instantly at temperatures above 158 degrees F (70 degrees C). General protection against the bacteria can be achieved by designing an operating water temperature of at least 140 degrees F (60 degrees C) or higher. As temperatures increase, so does the risk of scalding.

For system water temperatures below 140 Degrees F (60 Degrees C) special provisions are necessary to allow for cleaning and chemical treatment procedures for addressing the Legionellae Bacteria in the Domestic Hot Water System. Given a storage temperature of 140 degrees Fahrenheit that should be high enough to protect the water heater from the bacteria, but in open systems with Legionellae bacteria in the municipal water supply, it would continually re-seed the potable hot water system with high dosages of potentially Legionellae bacteria infested water. This is another reason why combined systems should have a closed loop for the heating hot water system.

Pitfall Number 22 - Leakage of Boiler Water. When boiler water is at a higher temperature than 140 degrees Fahrenheit, (180 to 210 degrees Fahrenheit) and it is allowed to leak through a faulty zone valve or solenoid valve if there is debris in the line or if the boiler water is allowed to flow by gravity circulation through a circulating pump that is

de-energized, there is the potential for overheating the domestic hot water. In these cases a system can have a thermostat set to de-energize the circulating pumps or close the solenoid valve and if they leak, the domestic hot water can rise above the set point to a temperature close to the boiler water temperature. A thermostat that controls a solenoid valve or circulating pumps on the water heater should never be used to control the temperature in a domestic hot water system because thermostats allow too much of a temperature variation from when it senses the water to turn on or off the pump or solenoid valve and there is potential for leakage and temperature creep. The best way to address this is to provide a thermostatic mixing valve that conforms to ASSE 1017 on the domestic hot water line coming from the hot water tank to provide a safe hot water distribution temperature. If you are considering a combined system, avoiding these pitfalls listed above should help keep your building warm and the occupants in a safe temperature of hot water. If you don't avoid these pitfalls you could find yourself in hot water. Another option would be to keep life simple and keep the systems separate. Then you will not have to worry about someone coming along later and messing up your system design with system modifications or poor maintenance that can create scalding issues then steer clear of combined heating hot water and domestic hot water systems and you will steer clear of potential litigation also.

Cost Impact

The code change proposal will increase the cost of construction .

A combination water heater/space heater equipment will cost more.

Internal ID: 2380

P71-18 Part I

IPC: 501.2, 607.2.2

Proponent: Pennie Feehan, representing Plumbing, Mechanical, and Fuel Gas Code Action Committee (PMGCAC@iccsafe.org)

THIS IS A 2 PART CODE CHANGE PROPOSAL. PART I WILL BE HEARD BY THE IPC COMMITTEE. PART II WILL BE HEARD BY THE IRC-PLUMBING COMMITTEE. SEE THE TENTATIVE HEARING ORDERS FOR THESE COMMITTEES.

2018 International Plumbing Code

Revise as follows:

501.2 Water heater as space heater. Where a combination potable water heating and space heating system requires water for space heating at temperatures greater than 140°F (60°C), a ~~master thermostatic temperature-actuated~~ mixing valve complying with ASSE 1017 shall be provided to limit the water supplied to the potable *hot water* distribution system to a temperature of 140°F (60°C) or less. The potability of the water shall be maintained throughout the system.

607.2.2 Piping for recirculation systems having ~~master thermostatic temperature-actuated~~ mixing valves. Where a ~~thermostatic temperature-actuated~~ mixing valve is used in a system with a hot water recirculating pump, the *hot water* or *tempered water* return line shall be routed to the cold water inlet pipe of the water heater and the cold water inlet pipe or the hot water return connection of the ~~thermostatic temperature-actuated~~ mixing valve.

Internal ID: 528

P71-18 Part II

IRC: P2802.1, P2803.2

Proponent: Pennie Feehan, representing Plumbing, Mechanical, and Fuel Gas Code Action Committee (PMGCAC@iccsafe.org)

2018 International Residential Code

Revise as follows:

P2802.1 Water temperature control. Where heated water is discharged from a solar thermal system to a *hot water* distribution system, a ~~thermostatic-temperature-actuated~~ mixing valve complying with ASSE 1017 shall be installed to temper the water to a temperature of not greater than 140°F (60°C). Solar thermal systems supplying *hot water* for both space heating and domestic uses shall comply with Section P2803.2. A temperature-indicating device shall be installed to indicate the temperature of the water discharged from the outlet of the mixing valve. The ~~thermostatic-temperature-actuated~~ mixing valve required by this section shall not be a substitute for water-temperature limiting devices required by Chapter 27 for specific fixtures.

P2803.2 Temperature control. Where a combination water heater-space heating system requires water for space heating at temperatures exceeding 140°F (60°C), a ~~master thermostatic-temperature-actuated~~ mixing valve complying with ASSE 1017 shall be installed to temper the water to a temperature of not greater than 140°F (60°C) for domestic uses.

Reason:

This proposal is almost editorial in nature as it is simply making the terminology (for the same component), consistent everywhere it is used in the code. The code currently uses different terminology to describe mixing valves complying with ASSE 1017: “master thermostatic valves” and “temper-actuated mixing valves”. There are also variations: “master thermostatic mixing valve,” “master thermostatic valves,” and “thermostatic mixing valve.” For consistency, the code needs to use the same terminology everywhere and that terminology should be aligned with title of the ASSE 1017 standard: “... Temperature-Actuated Mixing Valves for Hot Water Distribution Systems.” Note that IPC Section 613.1 and IRC P2724.1 already use the proposed terminology. Those sections indicate the location for such valves: at the hot water source. This aligns with manufacturer’s instructions and the listing for ASSE 1017 valves. Thus, there is no need for the ambiguous term of “master” in the code.

This proposal is submitted by the ICC Plumbing/Mechanical/Gas Code Action Committee (PMG CAC). The PMG CAC was established by the ICC Board of Directors to pursue opportunities to improve and enhance the International Codes or portions thereof that were under the purview of the PMG CAC. In 2017 the PMG CAC held one face-to-face meeting and 11 conference call meetings. Numerous interested parties attended the committee meetings and offered their input.

Cost Impact

The code change proposal will not increase or decrease the cost of construction .

This proposal will not increase the cost of construction because no additional labor, materials, equipment, appliances or devices are mandated beyond what is currently required by the code.

Internal ID: 3426

P72-18

IPC: 501.8

Proponent: Ronald George, Plumb-Tech Design & Consulting Services LLC, representing Self (Ron@Plumb-TechLLC.com)

2018 International Plumbing Code

Revise as follows:

501.8 ~~Temperature-Water heater thermostat controls.~~ Hot water supply systems-Water heaters shall be equipped with automatic temperature controls capable of adjustments from the lowest to the highest acceptable temperature settings for the intended temperature operating range. The water heater thermostat shall not be used by itself for scald prevention or to limit the hot water temperatures being delivered to the plumbing fixtures as required in Chapter 4 of this code.

Reason:

The water heater thermostat should not be relied upon to accurately control the hot water system delivery temperature. The thermostat is located in the bottom of the water heater and is intended to only sense the incoming cold water and anticipate the need for hot water by turning the burner "ON" and "OFF". There is no temperature sensor in the top of a storage type water heater and the combination gas control valve and thermostat cannot sense or control the temperature of the hot water in the top of the tank or the outlet temperature. When there are intermittent short draws of hot water, the short draws of cold water enter the bottom of the heater and cause the burner to cycle "ON". This creates a condition known as stacking where the already heated water in the top of the heater gets overheated with each consecutive intermittent burner cycle from a short draw of water. (2-3 gallons) The hot water can exceed the water heater thermostat setting and therefore, thermostat dial on the water heater cannot be relied upon to accurately control the outlet temperature of the water heater. In some cases the hot water temperature can be as much as 30 or more degrees hotter than the thermostat setting on a water heater. This is why the thermostat on the water heater should not be used as a system temperature controller. Water heater thermostats are not tested for accurate control of temperatures on the outlet of the water heater. There are some newer water heaters on the market with sophisticated controls, but there is currently no industry standard test for verifying the ability of a water heater to accurately control the outlet hot water temperature. At 120 F a person would have about 5 minutes to get out of harms way, but with the inaccuracy of 30 degrees you can have the heater set at 120 F and get 150 F or hotter water from the water heater. At 150 F a person would be scalded in about 1-1/2 seconds. That would not be enough time to realize what is happening, react and try to adjust the temperature or get out of harms way. Even if the temperature was readjusted, it would still flow out of a shower head at the current temperature for about 6-10 more seconds (depending on the shower head flow rate) at the scalding hot temperature before the cooler water flowed out of the shower head. This would surely lead to serious burn injuries. This is already a requirement in other parts of the code for specific applications. This code change is just clarifying the language and adding it to the water heater chapter. By changing the code here, it covers all fixtures where scalding can occur.

Cost Impact

The code change proposal will not increase or decrease the cost of construction .

This is already a requirement in other parts of the code for specific applications. This code change is just clarifying the language and adding it to the water heater chapter.

Internal ID: 1992

P73-18

IPC: 502.4 (New), 502.4

Proponent: Richard Houle, Reliance Worldwide Corporation, representing Reliance Worldwide Corporation (rich.houle@rwc.com)

2018 International Plumbing Code

Add new text as follows:

502.4 Supports. Tank type water heaters shall be laterally supported to prevent the water heater from tipping over. The support shall be attached on the upper 1/3 of the tank. The support shall not compromise the outer shell of the tank and shall not violate the water heater manufacturer's installation requirements.

Revise as follows:

~~502.4~~ **502.4.1 Seismic supports.** Where earthquake loads are applicable in accordance with the International Building Code, water heater supports shall be designed and installed for the seismic forces in accordance with the International Building Code.

Reason:

Heavy equipment, especially those with a high center of gravity such as is a storage water heater, can be knocked over accidentally. When they do:

- a. There is the potential for bodily injury or death, should the equipment tip over onto a person
- b. There is the potential for a fire and/or explosion, should a fuel gas line be damaged or ruptured due to the equipment's movement.

In the case of a water heater or similar large water containing vessel, a vital source of potable water storage can be lost if the tank tips over and drains out onto the ground. This code requirement currently exists in the building code for equipment weighing 400 lbs or more. A 40 gallon water heater will weigh close to 400 lbs when filled with water.

Cost Impact

The code change proposal will increase the cost of construction .

A restraint strap kit is only about \$20 and takes about 15 minutes to install.

Internal ID: 1510

P74-18

IPC: 502.6 (New)

Proponent: Ronald George, representing Self (Ron@Plumb-TechLLC.com)

2018 International Plumbing Code

Add new text as follows:

502.6 Water Heater Replacement. When a water heater is replaced or repaired, all downstream hot water fixtures with temperature limit requirements, required in Chapter 4 of this code, shall be checked to make sure the maximum temperature limit-stops or other temperature limiting devices are properly adjusted to assure the maximum allowable temperature is not exceeded.
Where a downstream fixture has a non-code compliant shower or tub/shower valve, the valve shall be replaced with a code-compliant shower control, or other approved temperature control devices shall be installed to prevent scalding and thermal shock. The water heater thermostat shall not be used as a control for meeting this requirement.

Reason:

Many scald injuries are a result of a water heater replacement or water heater maintenance where the temperature is different upon completion of the work. It is a very important safety issue when a change has been made in the hot water distribution temperature to check all the maximum temperature limit-stop adjustments or temperature limiting devices downstream of the water heating equipment to prevent scalding incidents. Many scalding incidents occur even with code compliant shower valves or tempering valves when the incoming hot water temperature significantly changes to these devices. The American Society of Sanitary Engineering is working on a white paper addressing this issue. The white paper is intended to educate the industry about the issue, however, this code language is needed to mandate the checking and adjusting of the temperatures and allow enforcement of the issue. If this language is passed, an inspector can check fixtures downstream of a water heater after it is installed to assure the temperature limiting devices or temperature limit-stops have been adjusted properly in order to ensure a safe installation.

Cost Impact

The code change proposal will not increase or decrease the cost of construction .

There is no material cost associated with this code change. this is simply giving the installer direction and the code official the authority to check for this very important and potentially deadly safety issue.

Internal ID: 1964

P75-18

IPC: 504.7

Proponent: Ronald George, representing Code Study & Development Committee of Southeast Michigan (Ron@Plumb-TechLLC.com)

2018 International Plumbing Code

Revise as follows:

504.7 Required pan. Where a ~~storage tank type~~ water heater or a hot water storage tank is installed in a location where water leakage ~~from the tank~~ will cause damage, the ~~tank water heater~~ shall be installed in a pan constructed of one of the following:

1. Galvanized steel or aluminum of not less than 0.0236 inch (0.6010 mm) in thickness.
2. Plastic not less than 0.036 inch (0.9 mm) in thickness.
3. Other *approved* materials.

A plastic pan shall not be installed beneath a gas-fired water heater.

Exception: Drain pans shall not be required under tankless water heaters installed under lavatories or sinks in rooms having water impervious floors and where any leaks from the heater would be readily observable.

Reason:

During the last code change cycle, this section was changed to address drain pans for only tank-type water heaters. All water heaters can leak at some point and any water heater that can leak and cause water damage to a building structure should have a drain pan installed. The purpose of this section is to prevent water damage to the building. The code language as it currently is written does not provide protection for water heaters other than tank type heaters. Other types of water heaters, can fail and cause water damage to buildings, but the current code language only addresses tank type heaters. The proponent in the last code cycle tried to make tankless heaters exempt from drain pan and mentioned the intent was to not require drain pans under tankless water heaters in a bathroom. They should have proposed an exception addressing the tankless heaters. As written the section only applies to tank type water heater and does not distinguish a location. Tankless heaters, copper fin tube water heaters, instantaneous heaters, plate & frame heat exchangers and water tube boilers used as water heaters, and shell & tube heat exchangers used as water heaters are all not classified as tank type heaters. These larger style water heaters should have drain pans installed under them if they are installed in an attic or in another areas that could cause damage to the building from a leak. This code change proposal corrects this oversight and adds an exception for tankless heaters in bathrooms.

Cost Impact

The code change proposal will increase the cost of construction .

There will be the added cost and labor for some tankless water heater installations needing a pan (with a pan drain.)

Internal ID: 1109

P76-18

IPC: 202, 601.5

Proponent: Sidney Cavanaugh, representing LMK Technologies (sidneycavanaugh@yahoo.com)

2018 International Plumbing Code

SECTION 202 GENERAL DEFINITIONS

Add new definition as follows:

PRESSURE PIPING REHABILITATION. The process of the scouring or cleaning the interior surface of pressure pipe or fittings followed by resurfacing with epoxy or epoxy resin to create a smooth interior service to restore the original performance to the pipes and fittings.

Revise as follows:

601.5 Rehabilitation of pressure piping systems. ~~Where pressure piping systems are rehabilitated using an~~The epoxy lining system , such lining system for pressure piping rehabilitation shall comply with ASTM F 2831.

Reason:

To add needed definition for rehabilitation as it relates to pressure piping systems to the IPC

Cost Impact

The code change proposal will not increase or decrease the cost of construction .

This is simply a definition to clarify what rehabilitation of pressure piping is. Section 601.5 is only changed to make it agree with the new defined term.

Internal ID: 508

P77-18 Part I

IPC: 602.3.5

Proponent: Jeremy Brown, representing NSF International (brown@nsf.org)

THIS IS A 2 PART CODE CHANGE PROPOSAL. PART I WILL BE HEARD BY THE IPC COMMITTEE. PART II WILL BE HEARD BY THE IRC-PLUMBING COMMITTEE. SEE THE TENTATIVE HEARING ORDERS FOR THESE COMMITTEES.

2018 International Plumbing Code

Revise as follows:

602.3.5 Pumps. Pumps shall be rated for the transport of potable water. Pumps in an individual water supply system shall be constructed and installed so as to prevent contamination from entering a potable water supply through the pump units. Pumps intended to supply drinking water shall conform to NSF 61. Pumps shall be sealed to the well casing or covered with a water-tight seal. Pumps shall be designed to maintain a prime and installed such that ready access is provided to the pump parts of the entire assembly for repairs.

Internal ID: 145

P77-18 Part II

IRC: P2903.3.1 (New)

Proponent: Jeremy Brown, representing NSF International (brown@nsf.org)

2018 International Residential Code

Add new text as follows:

P2903.3.1 Pumps handling drinking water. Pumps intended to supply drinking water shall conform to NSF 61.

Reason:

The code would be more protective of public health if it required pumps to meet requirements of NSF 61. NSF/ANSI Standard 61 Drinking Water System Components-Health Effects helps to ensure that products/materials will not contribute harmful levels of contaminants to drinking water. The current IPC and IRC already requires conformance to NSF 61 for pipes, fittings, faucets, valves and tanks intended to supply drinking water. This requirement should also apply to pumps.

Pumps are within the scope of NSF 61 (as are virtually all drinking water system components).

Cost Impact

The code change proposal will not increase or decrease the cost of construction .

Because of the wide variety of NSF 61 certified pumps and most specifications requiring NSF 61 already, this change is not expected to increase the cost of construction.

Internal ID: 3422

P78-18

IPC: 604.1, CHAPTER 15

Proponent: Connor Barbaree, ASHRAE, representing ASHRAE (cbarbaree@ashrae.org)

2018 International Plumbing Code

Revise as follows:

604.1 General. The design of the water distribution system shall be in accordance with ASHRAE 188 and shall conform to *accepted engineering practice*. Methods utilized to determine pipe sizes shall be *approved*.

Add new standard(s) follows:

ASHRAE

ASHRAE
1791 Tullie Circle NE
Atlanta GA 30329

ASHRAE 188-2018:

Legionellosis: Risk Management for Building Water Systems (ANSI/ASHRAE Approved)

Reason:

ASHRAE Standard 188 was developed with the intent of providing code officials and building operators information on how to manage the risk of legionellosis. . ASHRAE Standard 188 was published on June 26, 2015, and is now publicly available as a final, published ANSI Standard. ASHRAE Standard 188 (2018) has been in continuous maintenance, and several addenda have been approved and published, as well as improvements in code compatible language which will be incorporated into the published 2018 standard. There are many design considerations in the ASHRAE standard that will help minimize Legionella bacteria growth in building water systems which can lead to Legionnaires Disease when water droplets are aerosolized from shower heads, and other building water systems and fixtures that aerosolize water droplets. Following the ASHRAE Standard will minimize the risk of a Person contracting Legionnaires' disease.

For more information on the standard, go here: <http://www.techstreet.com/ashrae/products/1897561>

Bibliography:

www.LegionellaPrevention.org

www.Plumb-TechLLC.com

Cost Impact

The code change proposal will increase the cost of construction .

The cost of construction of the plumbing system to eliminate dead legs and provide other design concepts to address temperature and stagnation is estimated to be about 10 - 15 percent more to comply with this standard, however it will provide for hygienic system designs that will minimize legionella bacteria growth and help prevent Legionnaires Disease. See www.LegionellaPrevention.org.

Analysis: A review of the standard proposed for inclusion in the code, ASHRAE 188-2018, with regard to the ICC criteria for referenced standards (Section 3.6 of CP#28) will be posted on the ICC website on or before April 2, 2018.

Internal ID: 358

P79-18 Part I

IPC: 604.3, TABLE 604.3

Proponent: Donald Surrena, National Association of Home Builders, representing National Association of Home Builders (dsurrena@nahb.org)

THIS IS A 2 PART CODE CHANGE PROPOSAL. PART I WILL BE HEARD BY THE IPC COMMITTEE. PART II WILL BE HEARD BY THE IRC-PLUMBING COMMITTEE. SEE THE TENTATIVE HEARING ORDERS FOR THESE COMMITTEES.

2018 International Plumbing Code

Revise as follows:

604.3 Water distribution system design criteria. The water distribution system shall be designed, and pipe sizes shall be selected such that under conditions of sized for peak demand, the capacities at the fixture supply pipe outlets shall be not less than using the values shown in Table 604.3. The minimum flow rate and flow pressure provided to fixtures and appliances not listed in Table 604.3 shall be in accordance with the manufacturer's installation instructions.

TABLE 604.3
FLOW RATES AND PRESSURES FOR DESIGNING WATER DISTRIBUTION SYSTEM DESIGN CRITERIA REQUIRED
CAPACITY AT FIXTURE SUPPLY PIPE OUTLET SYSTEMS

FIXTURE SUPPLY OUTLET SERVING	FLOW RATE^a (gpm)	FLOW PRESSURE (psi)
Bathtub, balanced-pressure, thermostatic or combination balanced-pressure/thermostatic mixing valve	4	20
Bidet, thermostatic mixing valve	2	20
Combination fixture	4	8
Dishwasher, residential	2.75	8
Drinking fountain	0.75	8
Laundry tray	4	8
Lavatory, private	0.8	8
Lavatory, private, mixing valve	0.8	8
Lavatory, public	0.4	8
Shower	2.5	8
Shower, balanced-pressure, thermostatic or combination balanced-pressure/thermostatic mixing valve	2.5 ^b	20
Sillcock, hose bibb	5	8
Sink, residential	1.75	8
Sink, service	3	8
Urinal, valve	12	25
Water closet, blow out, flushometer valve	25	45
Water closet, flushometer tank	1.6	20
Water closet, siphonic, flushometer valve	25	35
Water closet, tank, close coupled	3	20
Water closet, tank, one piece	6	20

For SI: 1 pound per square inch = 6.895 kPa, 1 gallon per minute = 3.785 L/m.

- a. For additional requirements for flow rates and quantities, see Section 604.4.
- b. Where the shower mixing valve manufacturer indicates a lower flow rating for the mixing valve, the lower value shall be applied.

Internal ID: 1351

P79-18 Part II

IRC: P2903.1, TABLE P2903.1

Proponent: Donald Surrena, National Association of Home Builders, representing National Association of Home Builders (dsurrena@nahb.org)

2018 International Residential Code

Revise as follows:

P2903.1 Water supply system design criteria. The water service and water distribution systems shall be designed and ~~pipe sizes shall be selected such that under conditions of~~ sized for peak demand, ~~the capacities at the point of outlet discharge shall be not less than~~ using values shown in Table P2903.1.

TABLE P2903.1**REQUIRED CAPACITIES AT POINT OF OUTLET DISCHARGE FLOW RATE AND PRESSURES FOR DESIGNING PIPING SYSTEMS**

FIXTURE SUPPLY OUTLET SERVING	FLOW RATE (gpm)	FLOW PRESSURE (psi)
Bathtub, balanced-pressure, thermostatic or combination balanced-pressure/thermostatic mixing valve	4	20
Bidet, thermostatic mixing valve	2	20
Dishwasher	2.75	8
Laundry tray	4	8
Lavatory	0.8	8
Shower, balanced-pressure, thermostatic or combination balanced-pressure/thermostatic mixing valve	2.5 ^a	20
Sillcock, hose bibb	5	8
Sink	1.75	8
Water closet, flushometer tank	1.6	20
Water closet, tank, close coupled	3	20
Water closet, tank, one-piece	6	20

For SI: 1 pound per square inch = 6.895 kPa, 1 gallon per minute = 3.785 L/m.

- a. Where the shower mixing valve manufacturer indicates a lower flow rating for the mixing valve, the lower value shall be applied.

Reason:

The section and the table were intended to be used to set design capacities for the domestic water systems, not for field testing. With the emphasis on low flow fixtures and lower flow rating for mixing valves these numbers are causing confusion and misinterpretation in the field. Looking at the table what would be the health or safety reason for a bathtub to be required to flow at 4 gpm at 20 psi, or a water closet at 6 gpm at 20 psi or even 3 gpm at 20 psi as the table states? Balanced mixing valves are shown as 2.5 gpm at 20 psi or even lower if the manufacturer indicates. How does the inspector regulate the psi from 20 to 8 depending on the fixture being measured? These are all design specifications and not volumes to be measured at the fixture at differing psi.

Cost Impact

The code change proposal will not increase or decrease the cost of construction .

This is a clarification change that will not impact the cost of construction.

Internal ID: 1344

P80-18

IPC: 604.3.1 (New), Chapter 15

Proponent: Ronald George, Plumb-Tech Design & Consulting Services LLC, representing Self (Ron@Plumb-TechLLC.com)

2018 International Plumbing Code

Add new text as follows:

604.3.1 System design for building water safety. Design of water distribution systems shall comply with Chapters 1 through 8 of ASHRAE 188.

Add new standard(s) follows:

ASHRAE

ASHRAE
1791 Tullie Circle NE
Atlanta GA 30329

188-2015:

Legionellosis: Risk Management for Building Water Systems.

Reason:

Since the last code cycle, ASHRAE completed standard 188 titled: Legionellosis: Risk Management for Building Water Systems. Chapter 8 covers items that need to be considered during the design stage of a domestic water system. This is especially important since the water flow from plumbing fixtures have been reduced to about 20% of the flows prior to the 1992 Energy Policy Act which established maximum flow rates for plumbing fixtures. These lower flow rates are allowing "Aging Water" which is allowing water treatment chemicals (like Chlorine, Monochlorine, etc.) to dissipate to levels that are not capable of controlling bacteria growth in buildings. As other water conservation programs are enacted to further reduce flow rates, there are more and more reported cases of Legionellosis or Legionnaires' disease. This code change includes design considerations to control the risk of Legionella bacteria growth.

Cost Impact

The code change proposal will not increase or decrease the cost of construction .

This proposal only offers direction to designers on how to better organize piping systems that are already required. Better piping organization doesn't cause any more or less cost for materials or labor.

Analysis: A review of the standard proposed for inclusion in the code, ASHRAE 188-2015, with regard to the ICC criteria for referenced standards (Section 3.6 of CP#28) will be posted on the ICC website on or before April 2, 2018.

Internal ID: 2081

P81-18

IPC: TABLE 604.4

Proponent: Anthony Floyd, City of Scottsdale, representing City of Scottsdale (afloyd@scottsdaleaz.gov)

2018 International Plumbing Code

Revise as follows:

**TABLE 604.4
 MAXIMUM FLOW RATES AND CONSUMPTION FOR PLUMBING FIXTURES AND FIXTURE FITTINGS**

PLUMBING FIXTURE OR FIXTURE FITTING	MAXIMUM FLOW RATE OR QUANTITY^b
Lavatory, private	2.2 gpm at 60 psi
Lavatory, public (metering)	0.25 gallon per metering cycle
Lavatory, public (other than metering)	0.5 gpm at 60 psi
Shower head ^a	2.5 gpm at 80 psi
Sink faucet	2.2 gpm at 60 psi
Urinal	1.0 0.5 gallon per flushing cycle
Water closet	1.6 gallons per flushing cycle

For SI: 1 gallon = 3.785 L, 1 gallon per minute = 3.785 L/m, 1 pound per square inch = 6.895 kPa.

- a. A hand-held shower spray is a shower head.
- b. Consumption tolerances shall be determined from referenced standards.

Reason:

Urinals account for a significant portion of indoor water usage in commercial and institutional settings. Manufacturers have responded with superior and better-performing urinals having a maximum flush rate of 0.5 gallons, without sacrificing performance.

All water flushing urinals produce calcite build-up in the urinal trapway and drain pipes caused by the bonding of the mineral ions in the flushing water with the sediment in urine. As such, build-up occurs in all water flushing urinals from 1.0 gpf down to 0.1 gpf and is not any greater for 0.5 gpf urinals.

Based on WaterSense product listings from January 2018, there are 160 models of flushing urinals from 20 brands and 239 models of urinal valves from 20 brands that meet the 0.5 gpf criterion, demonstrating widespread availability and commercial viability of more efficient urinals.

Bibliography:

EPA WaterSense - <https://www.epa.gov/watersense/urinals>

Considerations for Reduced Water Consumption Rates of Urinal Fixtures (Sloan Valve) - <https://www.sloan.com/sites/default/files/2016-01/hybrid-urinal-whitepaper.pdf>

Cost Impact

The code change proposal will not increase or decrease the cost of construction .

There is no appreciable cost difference between urinal flush valves at 0.5gpf and 1.0 gpf .

Internal ID: 1530

P82-18 Part I

IPC: TABLE 604.4

Proponent: Anthony Floyd, City of Scottsdale, representing City of Scottsdale (afloyd@scottsdaleaz.gov)

THIS IS A 2 PART CODE CHANGE PROPOSAL. PART I WILL BE HEARD BY THE IPC COMMITTEE. PART II WILL BE HEARD BY THE IRC-PLUMBING COMMITTEE. SEE THE TENTATIVE HEARING ORDERS FOR THESE COMMITTEES.

2018 International Plumbing Code

Revise as follows:

**TABLE 604.4
 MAXIMUM FLOW RATES AND CONSUMPTION FOR PLUMBING FIXTURES AND FIXTURE FITTINGS**

PLUMBING FIXTURE OR FIXTURE FITTING	MAXIMUM FLOW RATE OR QUANTITY^b
Lavatory, private	2.2 gpm at 60 psi
Lavatory, public (metering)	0.25 gallon per metering cycle
Lavatory, public (other than metering)	0.5 gpm at 60 psi
Shower head ^{a,c}	2.5 gpm at 80 psi
Sink faucet	2.2 gpm at 60 psi
Urinal	1.0 gallon per flushing cycle
Water closet	1.6 gallons per flushing cycle

For SI: 1 gallon = 3.785 L, 1 gallon per minute = 3.785 L/m, 1 pound per square inch = 6.895 kPa.

- a. A hand-held shower spray is a shower head.
- b. Consumption tolerances shall be determined from referenced standards.
- c. Where a shower compartment is served by multiple shower heads, the concurrent discharge of all shower heads controlled by a single valve shall not exceed the maximum flow rate.

Internal ID: 556

P82-18 Part II

IRC: TABLE P2903.2

Proponent: Anthony Floyd, City of Scottsdale, representing City of Scottsdale (afloyd@scottsdaleaz.gov)

2018 International Residential Code

Revise as follows:

TABLE P2903.2
MAXIMUM FLOW RATES AND CONSUMPTION FOR PLUMBING FIXTURES AND FIXTURE FITTINGS^b

PLUMBING FIXTURE OR FIXTURE FITTING	MAXIMUM FLOW RATE OR QUANTITY
Lavatory faucet	2.2 gpm at 60 psi
Shower head ^{a,c}	2.5 gpm at 80 psi
Sink faucet	2.2 gpm at 60 psi
Water closet	1.6 gallons per flushing cycle

For SI: 1 gallon per minute = 3.785 L/m, 1 pound per square inch = 6.895 kPa.

- a. A handheld shower spray shall be considered to be a shower head.
- b. Consumption tolerances shall be determined from referenced standards.
- c. Where a shower compartment is served by multiple shower heads, the concurrent discharge of all shower heads controlled by a single valve shall not exceed the maximum flow rate.

Reason:

This code change limits the combined shower head flow rate to 2.5 gpm where multiple heads are installed unless the shower is designed to allow only one shower head to operate at a time.

Multiple shower heads were not common when EAct was enacted 25 years ago to limit the flow rate of shower heads. Since then, shower compartments have trended towards multiple shower heads and body sprays.

This code change ensures that where a shower compartment is served by multiple shower heads, the maximum flow rate is 1) controlled by a single valve for each shower head, 2) designed to allow only one shower head to be in operation at a time or 3) controlled by a single valve for the combined flow rate of multiple heads not exceeding the maximum flow rate.

Shower compartments with multiple showering stations are typically provided with a separate valve for each shower head. Shared shower compartments with separate valve controls are common features and meet the intent of this code change.

Cost Impact

The code change proposal will not increase or decrease the cost of construction .

The code change is based on the shower compartment design and number of installed shower heads. It does not require any additional fixtures or valves to be installed.

Internal ID: 553

P83-18

IPC: TABLE 605.3, Chapter 15

Proponent: Pennie Feehan, representing Plumbing, Mechanical, and Fuel Gas Code Action Committee (PMGCAC@iccsafe.org)

2018 International Plumbing Code

Revise as follows:

**TABLE 605.3
WATER SERVICE PIPE**

MATERIAL	STANDARD
Acrylonitrile butadiene styrene (ABS) plastic pipe	ASTM D1527; ASTM D2282
Chlorinated polyvinyl chloride (CPVC) plastic pipe	ASTM D2846; ASTM F441; ASTM F442; CSA B137.6
Chlorinated polyvinyl chloride/aluminum/chlorinated polyvinyl chloride (CPVC/AL/CPVC)	ASTM F2855
Copper or copper-alloy pipe	ASTM B42; ASTM B302
Copper or copper-alloy tubing (Type K, WK, L, WL, M or WM)	ASTM B75; ASTM B88; ASTM B251; ASTM B447
Cross-linked polyethylene (PEX) plastic pipe and tubing	ASTM F876; AWWA C904; CSA B137.5
Cross-linked polyethylene/aluminum/cross-linked polyethylene (PEX-AL-PEX) pipe	ASTM F1281; ASTM F2262; CSA B137.10
Cross-linked polyethylene/aluminum/high-density polyethylene (PEX-AL-HDPE)	ASTM F1986
Ductile iron water pipe	AWWA C151/A21.51; AWWA C115/A21.15
Galvanized steel pipe	ASTM A53
Polyethylene (PE) plastic pipe	ASTM D2239; ASTM D3035; AWWA C901; CSA B137.11
Polyethylene (PE) plastic tubing	ASTM D2737; AWWA C901; CSA B137.1
Polyethylene/aluminum/polyethylene (PE-AL-PE) pipe	ASTM F1282; CSA B137.9
Polyethylene of raised temperature (PE-RT) plastic tubing	ASTM F2769; CSA B137.18
Polypropylene (PP) plastic pipe or tubing	ASTM F2389; CSA B137.11
Polyvinyl chloride (PVC) plastic pipe	ASTM D 1785; ASTM D2241; ASTM D2672; CSA B137.3
Stainless steel pipe (Type 304/304L)	<u>ASTM A269</u> ; ASTM A312; ASTM A778
Stainless steel pipe (Type 316/316L)	<u>ASTM A269</u> ; ASTM A312; ASTM A778

Add new standard(s) follows:

ASTM

ASTM International
100 Barr Harbor Drive, P.O. Box
C700
West Conshohocken PA 19428-
2959
US

A269/A269M-15a:

Standard Specification for Seamless and Welded Austenitic Stainless Steel Tubing for General

Reason:

Adding another standard for stainless steel piping into the code increases flexibility in choices of piping.

This proposal is submitted by the ICC Plumbing/Mechanical/Gas Code Action Committee (PMG CAC). The PMG CAC was established by the ICC Board of Directors to pursue opportunities to improve and enhance the International Codes or portions thereof that were under the purview of the PMG CAC. In 2017 the PMG CAC held one face-to-face meeting and 11 conference call meetings. Numerous interested parties attended the committee meetings and offered their input.

Cost Impact

The code change proposal will not increase or decrease the cost of construction .

This proposal is a clarification of existing requirements. No new materials or labor are required by this proposal thus, there is not a cost increase.

Analysis: A review of the standard proposed for inclusion in the code, ASTM A269 / A269M - 15a, with regard to the ICC criteria for referenced standards (Section 3.6 of CP#28) will be posted on the ICC website on or before April 2, 2018.

Internal ID: 506

P84-18

IPC: TABLE 605.3

Proponent: Pennie L Feehan, Copper Development Association, representing Copper Development Association (penniefeehan@me.com)

2018 International Plumbing Code

Revise as follows:

**TABLE 605.3
WATER SERVICE PIPE**

MATERIAL	STANDARD
Acrylonitrile butadiene styrene (ABS) plastic pipe	ASTM D1527; ASTM D2282
Chlorinated polyvinyl chloride (CPVC) plastic pipe	ASTM D2846; ASTM F441; ASTM F442; CSA B137.6
Chlorinated polyvinyl chloride/aluminum/chlorinated polyvinyl chloride (CPVC/AL/CPVC)	ASTM F2855
Copper or copper-alloy pipe	ASTM B42; <u>ASTM B43</u> , ASTM B302,
Copper or copper-alloy tubing (Type K, WK, L, WL, M or WM)	ASTM B75; ASTM B88; ASTM B251; ASTM B447
Cross-linked polyethylene (PEX) plastic pipe and tubing	ASTM F876; AWWA C904; CSA B137.5
Cross-linked polyethylene/aluminum/cross-linked polyethylene (PEX-AL-PEX) pipe	ASTM F1281; ASTM F2262; CSA B137.10
Cross-linked polyethylene/aluminum/high-density polyethylene (PEX-AL-HDPE)	ASTM F1986
Ductile iron water pipe	AWWA C151/A21.51; AWWA C115/A21.15
Galvanized steel pipe	ASTM A53
Polyethylene (PE) plastic pipe	ASTM D2239; ASTM D3035; AWWA C901; CSA B137.11
Polyethylene (PE) plastic tubing	ASTM D2737; AWWA C901; CSA B137.1
Polyethylene/aluminum/polyethylene (PE-AL-PE) pipe	ASTM F1282; CSA B137.9
Polyethylene of raised temperature (PE-RT) plastic tubing	ASTM F2769; CSA B137.18
Polypropylene (PP) plastic pipe or tubing	ASTM F2389; CSA B137.11
Polyvinyl chloride (PVC) plastic pipe	ASTM D 1785; ASTM D2241; ASTM D2672; CSA B137.3
Stainless steel pipe (Type 304/304L)	ASTM A312; ASTM A778
Stainless steel pipe (Type 316/316L)	ASTM A312; ASTM A778

Reason:

When combining copper and copper alloy sections, this Standard ASTM B43 was accidentally removed from IPC Water Service Pipe Table 605.3. It is in IPC Water Distribution Pipe Table 605.4. It is also in the IRC Water Service Pipe Table 2906.4 and Water Distribution Pipe Table 2906.5. The IRC and the IPC need to correlate.

Cost Impact

The code change proposal will not increase or decrease the cost of construction .

Only adding a standard reference to the table to clarify the code.

Internal ID: 450

P85-18

IPC: TABLE 605.4

Proponent: Ronald George, Plumb-Tech Design & Consulting Services LLC, representing Code Study & Development Committee of Southeast Michigan (Ron@Plumb-TechLLC.com)

2018 International Plumbing Code

Revise as follows:

**TABLE 605.4
WATER DISTRIBUTION PIPE**

MATERIAL	STANDARD
Chlorinated polyvinyl chloride (CPVC) plastic pipe and tubing	ASTM D2846; ASTM F441; ASTM F442; CSA B137.6
Chlorinated polyvinyl chloride/aluminum/chlorinated polyvinyl chloride (CPVC/AL/CPVC)	ASTM F2855
Copper or copper-alloy pipe	ASTM B42; ASTM B302; ASTM B43
Copper or copper-alloy tubing (Type K, WK, L, WL, M or WM)	ASTM B75; ASTM B88; ASTM B251; ASTM B447
Cross-linked polyethylene (PEX) plastic tubing	ASTM F876; CSA B137.5
Cross-linked polyethylene/aluminum/cross-linked polyethylene (PEX-AL-PEX) pipe	ASTM F1281; ASTM F2262; CSA B137.10
Cross-linked polyethylene/aluminum/high-density polyethylene (PEX-AL-HDPE)	ASTM F1986
Ductile iron pipe	AWWA C151/A21.51; AWWA C115/A21.15
Galvanized steel pipe	ASTM A53
Polyethylene/aluminum/polyethylene (PE-AL-PE) composite pipe	ASTM F1282
Polyethylene of raised temperature (PE-RT) plastic tubing	ASTM F2769; CSA B137.158
Polypropylene (PP) plastic pipe or tubing	ASTM F2389; CSA B137.11
Stainless steel pipe (Type 304/304L)	ASTM A312; ASTM A778
Stainless steel pipe (Type 316/316L)	ASTM A312; ASTM A778

Reason:

Galvanized piping corrodes and causes water quality issues when it is installed in a potable water system. Galvanized piping also provides a rough surface for biofilm to cling to and flourish. This proposal is to remove galvanized piping as a pipe material for potable water systems. It can still be used in process water and non-potable water systems.

Cost Impact

The code change proposal will not increase or decrease the cost of construction .

This proposed changes will reduce the life cycle cost of the system because a system installed with galvanized pipe will need to be replaced after about 15 years or so, which is much shorter than the life expectancy for a typical building.

Internal ID: 2152

P86-18

IPC: TABLE 605.5, Chapter 15

Proponent: Mark Fasel, representing Viega LLC (mark.fasel@viega.us)

2018 International Plumbing Code

Revise as follows:

**TABLE 605.5
PIPE FITTINGS**

MATERIAL	STANDARD
Acrylonitrile butadiene styrene (ABS) plastic	ASTM D2468
Cast iron	ASME B16.4
Chlorinated polyvinyl chloride (CPVC) plastic	ASSE 1061; ASTM D2846; ASTM F437; ASTM F 438; ASTM F439; CSA B137.6
Copper or copper alloy	ASME B16.15; ASME B16.18; ASME B16.22; ASME B16.26; ASME B16.51; ASSE 1061; ASTM F1476; ASTM F1548; ASTM F3226
Cross-linked polyethylene/aluminum/high-density polyethylene (PEX-AL-HDPE)	ASTM F1986
Fittings for cross-linked polyethylene (PEX) plastic tubing	ASSE 1061, ASTM F877; ASTM F1807; ASTM F1960; ASTM F2080; ASTM F2098, ASTM F2159; ASTM F2434; ASTM F2735; CSA B137.5
Fittings for polyethylene of raised temperature (PE-RT) plastic tubing	ASSE 1061, ASTM D3261; ASTM F1807; ASTM F2098; ASTM F2159; ASTM F2735; ASTM F2769; CSA B137.18
Gray iron and ductile iron	ASTM F1476; ASTM F1548; AWWA C110/A21.10; AWWA C153/A21.53;
Insert fittings for polyethylene/aluminum/polyethylene (PE-AL-PE) and cross-linked polyethylene/aluminum/cross-linked polyethylene (PEX-AL-PEX)	ASTM F1974; ASTM F1281; ASTM F1282; CSA B137.9; CSA B137.10
Malleable iron	ASME B16.3
Metal (brass) insert fittings for polyethylene/aluminum/polyethylene (PE-AL-PE) and cross-linked polyethylene/aluminum/cross-linked polyethylene (PEX-AL-PEX)	ASTM F1974
Polyethylene (PE) plastic pipe	ASTM D2609; ASTM D2683; ASTM D3261; ASTM F1055; CSA B137.1
Polypropylene (PP) plastic pipe or tubing	ASTM F2389; CSA B137.11
Polyvinyl chloride (PVC) plastic	ASTM D2464; ASTM D2466; ASTM D2467; CSA B137.2; CSA B137.3
Stainless steel (Type 304/304L)	ASTM A312; ASTM A778; ASTM F1476; ASTM F1548; ASTM F3226

Stainless steel (Type 316/316L)	ASTM A312; ASTM A778; ASTM F1476; ASTM F1548; ASTM F3226
Steel	ASME B16.9; ASME B16.11; ASME B16.28; ASTM F1476; ASTM F1548

Add new standard(s) follows:

ASTM

ASTM International
100 Barr Harbor Drive, P.O. Box
C700
West Conshohocken PA 19428-
2959

F3226/F3226M-16:

Standard Specification for Metallic Press-Connect Fittings for Piping and Tubing

Reason:

ASTM F3226-16 Standard Specification for Metallic Press-Connect Fittings for Piping and Tubing Systems is now published and includes Carbon Steel, Stainless Steel, Copper and Copper-Alloy material grades. By including this standard will provide a reference standard for Stainless Steel Press-Connect Fittings and provide an additional Press-connect standard for Copper and copper alloy fittings.

Bibliography:

ASTM F3226 Standard Specification for Metallic Press-Connect Fittings for Piping and Tubing Systems

ASTM International

2016 edition

www.astm.org

Cost Impact

The code change proposal will not increase or decrease the cost of construction .

This standard is not the only standard that the pipe fittings can meet in accordance with the Pipe Fittings Table, this is just an alternative standard that some manufacturer's have tested their products to and would like to see recognized as an acceptable standard for pipe fittings. Testing to this standard is optional and no existing standards have been removed or replaced by the proposed addition of this standard.

Analysis: A review of the standard proposed for inclusion in the code, ASTM F3226/F3226M-16, with regard to the ICC criteria for referenced standards (Section 3.6 of CP#28) will be posted on the ICC website on or before April 2, 2018.

Internal ID: 744

P87-18 Part I

IPC: TABLE 605.5, Chapter 15

Proponent: Pennie Feehan, representing Plumbing, Mechanical, and Fuel Gas Code Action Committee
(PMGCAC@iccsafe.org)

THIS IS A 2 PART CODE CHANGE PROPOSAL. PART I WILL BE HEARD BY THE IPC COMMITTEE. PART II WILL BE HEARD BY THE IRC-PLUMBING COMMITTEE. SEE THE TENTATIVE HEARING ORDERS FOR THESE COMMITTEES.

2018 International Plumbing Code

Revise as follows:

**TABLE 605.5
PIPE FITTINGS**

MATERIAL	STANDARD
Acrylonitrile butadiene styrene (ABS) plastic	ASTM D2468
Cast iron	ASME B16.4
Chlorinated polyvinyl chloride (CPVC) plastic	ASSE 1061; ASTM D2846; ASTM F437; ASTM F 438; ASTM F439; CSA B137.6
Copper or copper alloy	ASME B16.15; ASME B16.18; ASME B16.22; ASME B16.26; ASME B16.51; ASSE 1061; ASTM F1476; ASTM F1548; ASTM F3226
Cross-linked polyethylene/aluminum/high-density polyethylene (PEX-AL-HDPE)	ASTM F1986
Fittings for cross-linked polyethylene (PEX) plastic tubing	ASSE 1061, ASTM F877; ASTM F1807; ASTM F1960; ASTM F2080; ASTM F2098, ASTM F2159; ASTM F2434; ASTM F2735; CSA B137.5
Fittings for polyethylene of raised temperature (PE-RT) plastic tubing	ASSE 1061, ASTM D3261; ASTM F1807; ASTM F2098; ASTM F2159; ASTM F2735; ASTM F2769; CSA B137.18
Gray iron and ductile iron	ASTM F1476; ASTM F1548; AWWA C110/A21.10; AWWA C153/A21.53;
Insert fittings for polyethylene/aluminum/polyethylene (PE-AL-PE) and cross-linked polyethylene/aluminum/cross-linked polyethylene (PEX-AL-PEX)	ASTM F1974; ASTM F1281; ASTM F1282; CSA B137.9; CSA B137.10
Malleable iron	ASME B16.3
Metal (brass) insert fittings for polyethylene/aluminum/polyethylene (PE-AL-PE) and cross-linked polyethylene/aluminum/cross-linked polyethylene (PEX-AL-PEX)	ASTM F1974
Polyethylene (PE) plastic pipe	ASTM D2609; ASTM D2683; ASTM D3261; ASTM F1055; CSA B137.1
Polypropylene (PP) plastic pipe or tubing	ASTM F2389; CSA B137.11
Polyvinyl chloride (PVC) plastic	ASTM D2464; ASTM D2466; ASTM D2467; CSA B137.2; CSA B137.3
Stainless steel (Type 304/304L)	ASTM A312; ASTM A778; ASTM F1476; ASTM F1548
Stainless steel (Type 316/316L)	ASTM A312:

	ASTM A778; ASTM F1476; ASTM F1548
Steel	ASME B16.9; ASME B16.11; ASME B16.28; ASTM F1476; ASTM F1548

Add new standard(s) follows:

ASTM

ASTM International
100 Barr Harbor Drive, P.O. Box
C700
West Conshohocken PA 19428-
2959

F3226/F3226M—16e1:

Standard Specification for Metallic Press-Connect Fittings for Piping and Tubing Systems

Analysis: A review of the standard proposed for inclusion in the code, F3226/F3226M—16e1, with regard to the ICC criteria for referenced standards (Section 3.6 of CP#28) will be posted on the ICC website on or before April 2, 2018.

Internal ID: 517

P87-18 Part II

IRC: T ABLE P2906.6, Chapter 44

Proponent: Pennie Feehan, representing Plumbing, Mechanical, and Fuel Gas Code Action Committee (PMGCAC@iccsafe.org)

2018 International Residential Code

Revise as follows:

**TABLE P2906.6
PIPE FITTINGS**

MATERIAL	STANDARD
Acrylonitrile butadiene styrene (ABS) plastic	ASTM D2468
Cast-iron	ASME B16.4
Chlorinated polyvinyl chloride (CPVC) plastic	ASSE 1061; ASTM D2846; ASTM F437; ASTM F438; ASTM F439; CSA B137.6
Copper or copper alloy	ASME B16.15; ASME B16.18; ASME B16.22; ASME B16.26; ASME B16.51; ASSE 1061; <u>ASTM F3226</u>
Cross-linked polyethylene/aluminum/high-density polyethylene (PEX-AL-HDPE)	ASTM F1986
Fittings for cross-linked polyethylene (PEX) plastic tubing	ASSE 1061; ASTM F877; ASTM F1807; ASTM F1960; ASTM F2080; ASTM F2098; ASTM F2159; ASTM F2434; ASTM F2735; CSA B137.5
Gray iron and ductile iron	AWWA C110/A21.10; AWWA C153/A21.53
Malleable iron	ASME B16.3
Insert fittings for Polyethylene/aluminum/polyethylene (PE-AL-PE) and cross-linked polyethylene/aluminum/cross-linked polyethylene (PEX-AL-PEX)	ASTM F1281; ASTM F1282; ASTM F1974; CSA B137.9; CSA B137.10
Polyethylene (PE) plastic	ASTM D 2609; CSA B137.1
Fittings for polyethylene of raised temperature (PE-RT) plastic tubing	ASSE 1061; ASTM D2683; ASTM D3261; ASTM F1055; ASTM F1807; ASTM F2098; ASTM F 2159; ASTM F2735; ASTM F2769; CSA B137.18
Polypropylene (PP) plastic pipe or tubing	ASTM F2389; CSA B137.11
Polyvinyl chloride (PVC) plastic	ASTM D2464; ASTM D2466; ASTM D2467; CSA B137.2; CSA B137.3
Stainless steel (Type 30 ⁴ / _{304L}) pipe	ASTM A312; ASTM A778
Stainless steel (Type 31 ⁶ / _{316L}) pipe	ASTM A312; ASTM A778
Steel	ASME B16.9; ASME B16.11; ASME B16.28

Add new standard(s) follows:

F3226 F3226/F3226M—16e1:

Standard Specification for Metallic Press-Connect Fittings for Piping and Tubing Systems

Reason:

Press-connect joint fittings now have an ASTM standard that needs to be included in the code.

This proposal is submitted by the ICC Plumbing/Mechanical/Gas Code Action Committee (PMG CAC). The PMG CAC was established by the ICC Board of Directors to pursue opportunities to improve and enhance the International Codes or portions thereof that were under the purview of the PMG CAC. In 2017 the PMG CAC held one face-to-face meeting and 11 conference call meetings. Numerous interested parties attended the committee meetings and offered their input.

Cost Impact

The code change proposal will not increase or decrease the cost of construction .

Press-connect joints are not required to be used-it is a designer or installer decision. No new materials or labor are required by this proposal thus, there is not a cost increase.

Analysis: A review of the standard proposed for inclusion in the code, ASTM F3226/F3226M-16e1, with regard to the ICC criteria for referenced standards (Section 3.6 of CP#28) will be posted on the ICC website on or before April 2, 2018.

Internal ID: 3430

P88-18 Part I

IPC: 605.12.3, 605.13.6

Proponent: Jeremy Brown, representing NSF International (brown@nsf.org)

THIS IS A 2 PART CODE CHANGE PROPOSAL. PART I WILL BE HEARD BY THE IPC COMMITTEE. PART II WILL BE HEARD BY THE IRC-PLUMBING COMMITTEE. SEE THE TENTATIVE HEARING ORDERS FOR THESE COMMITTEES.

2018 International Plumbing Code

Revise as follows:

605.12.3 Solder joints. Solder joints shall be made in accordance with ASTM B828. Cut tube ends shall be reamed to the full inside diameter of the tube end. Joint surfaces shall be cleaned. A flux conforming to ASTM B813 shall be applied. The joint shall be soldered with a solder conforming to ASTM B32. The joining of water supply piping shall be made with *lead-free solder and fluxes*. "Lead free" shall mean a chemical composition equal to or less than 0.2-percent lead. Solder and flux joining pipe or fittings intended to supply drinking water shall conform to NSF 61.

605.13.6 Solder joints. Solder joints shall be made in accordance with the methods of ASTM B828. Cut tube ends shall be reamed to the full inside diameter of the tube end. Joint surfaces shall be cleaned. A flux conforming to ASTM B813 shall be applied. The joint shall be soldered with a solder conforming to ASTM B32. The joining of water supply piping shall be made with *lead-free solder and flux*. "Lead free" shall mean a chemical composition equal to or less than 0.2-percent lead. Solder and flux joining pipe or fittings intended to supply drinking water shall conform to NSF 61.

Internal ID: 1232

P88-18 Part II

IRC: P2906.15

Proponent: Jeremy Brown, representing NSF International (brown@nsf.org)

2018 International Residential Code

Revise as follows:

P2906.15 Soldered and brazed joints. Soldered joints in copper and copper alloy tubing shall be made with fittings *approved* for water piping and shall conform to ASTM B828. Surfaces to be soldered shall be cleaned bright. Fluxes for soldering shall be in accordance with ASTM B813. Brazing fluxes shall be in accordance with AWS A5.31M/A5.31. Solders and fluxes used in potable water-supply systems shall have a lead content of not greater than 0.2 percent. Solder and flux joining pipe or fittings intended to supply drinking water shall conform to NSF 61.

Reason:

NSF/ANSI Standard 61 Drinking Water System Components-Health Effects helps to ensure that products/materials will not contribute harmful levels of contaminants to drinking water. The current IPC and IRC already requires conformance to NSF 61 for pipes, fittings, faucets, valves and tanks intended to supply drinking water. This requirement should also apply to solders and flux. The current requirements in this section address lead content only but do not address the potential for other chemical contaminants as NSF 61 does. The code would be more protective of public health if it required NSF 61.

Anyone wanting a copy of the standard for the purpose of reviewing this proposal may request a copy from brown@nsf.org.

Cost Impact

The code change proposal will not increase or decrease the cost of construction .

Because there are many products on the market meeting this requirement, this is not expected to increase the cost of construction.

Internal ID: 3420

P89-18 Part I

IPC: 202, 605.13.7

Proponent: William Chapin, Professional Code Consulting, LLC, representing Professional Code Consulting, LLC (bill@profcc.us)

THIS IS A 2 PART CODE CHANGE PROPOSAL. PART I WILL BE HEARD BY THE IPC COMMITTEE. PART II WILL BE HEARD BY THE IRC-PLUMBING COMMITTEE. SEE THE TENTATIVE HEARING ORDERS FOR THESE COMMITTEES.

2018 International Plumbing Code

Add new definition as follows:

SECTION 202 GENERAL DEFINITIONS

PUSH-FIT FITTING

A mechanical fitting that joins pipes or tubes and achieves a seal by mating the pipe or tube into the fitting.

Revise as follows:

605.13.7 Push-fit fitting joints. Push-fit fitting joints shall conform to ASSE 1061 and shall be installed in accordance with the manufacturer's instructions.

Internal ID: 2220

P89-18 Part II

IRC: R202, P2906.21

Proponent: William Chapin, Professional Code Consulting, LLC, representing Professional Code Consulting, LLC (bill@profcc.us)

2018 International Residential Code

Revise as follows:

P2906.21 Push-fit fitting joints. Push-fit fitting joints shall be used only on copper-tube-size outside diameter dimensioned CPVC, PEX and copper tubing. Push-fit joints shall conform to ASSE 1061 and shall be installed in accordance with the manufacturer's instructions.

Add new definition as follows:

SECTION R202 DEFINITIONS

PUSH-FIT FITTING

A mechanical fitting that joins pipes or tubes and achieves a seal by mating the pipe or tube into the fitting.

Reason:

Adding the definition from the ASSE 1061 standard for Push-fit fittings.

Cost Impact

The code change proposal will not increase or decrease the cost of construction .

Adding a definition does not affect the cost of construction.

Internal ID: 3438

P90-18

IPC: 605.23.1

Proponent: David Runnels, representing Select Ventures LLC (drunnels@selectventures.com)

2018 International Plumbing Code

Revise as follows:

605.23.1 Copper or copper-alloy tubing to ~~galvanized steel pipe, steel~~. Joints between copper pipe or tubing and ~~galvanized steel pipe, steel fittings or steel appliance connections~~ shall be made with a copper-alloy or dielectric fitting or a dielectric union conforming to ASSE 1079. The copper tubing shall be soldered to the fitting in an *approved* manner, and the fitting shall be screwed to the threaded ~~pipe~~ steel connection.

Reason:

This section as written requires the isolation of copper pipe from iron pipe. Without the isolation, electrolytic action will destroy the copper pipe and deposit copper inside the iron.

However, all of this will also occur if the copper pipe is in contact with ANYTHING iron - it need not be a pipe.

For this reason I am suggesting that the word "pipe" is supplemented to also include iron fittings and iron pumps and other appliances.

Furthermore, I am suggesting removal of the word "galvanized" from the section title and from the text of the section. The meaning is more clear, and the presence or absence of galvanizing is immaterial.

In our area (Tulsa, Oklahoma) we have a number of houses which were built in the early 1990s with copper water pipes under the floor slab. Those copper pipes on the hot water side are connected to an iron re-circulating pump and an (iron) water heater. The result is that the copper pipe deteriorates and leaks and the copper is deposited within the water heater. Ultimately, it is necessary to remove the slab and replace the pipe. Eventually it is also necessary to replace the water heater. In my house, we went through this entire process five times before I figured out the nature of the problem. The plumber never did notice.

Note that in these cases there is no iron pipe and nothing is galvanized. Technically our installation complies with the code!

Cost Impact

The code change proposal will increase the cost of construction .

This change will add to the construction cost the cost of one fitting (< \$10).

However, this change will reduce the cost of later repairs by approximately \$100,000.

Internal ID: 1929

P91-18

IPC: 606.1

Proponent: Guy McMann, representing Colorado Association of Plumbing and Mechanical Officials (CAPMO)
(gcmann@jeffco.us)

2018 International Plumbing Code

Revise as follows:

606.1 Location of full-open valves. Full-open valves shall be installed in the following locations:

1. On the building water service pipe from the public water supply near the curb.
2. On the water distribution supply pipe at the entrance into the structure.
 - 2.1 In multiple tenant buildings, where a common water supply piping system is installed to supply other than one and two family dwellings, a main shutoff valve shall be provided for each tenant.
3. On the discharge side of every water meter.
4. On the base of every water riser pipe in occupancies other than multiple-family residential occupancies that are two stories or less in height and in one- and two-family residential occupancies.
5. On the top of every water down-feed pipe in occupancies other than one- and two-family residential occupancies.
6. On the entrance to every water supply pipe to a dwelling unit, except where supplying a single fixture equipped with individual stops.
7. On the water supply pipe to a gravity or pressurized water tank.
8. On the water supply pipe to every water heater.

Reason:

It is a needless inconvenience to have to shut down an entire building when tenants need to work on their own water piping or in the case of emergencies. For the minimal cost of a valve, it makes sense to isolate tenant spaces just as what is done for gas piping. Opening the system causes air in pipes in other units that they might not be aware of and possibly causing a water hammer situation that can have a negative effect on the piping.

Cost Impact

The code change proposal will increase the cost of construction .

The increase will be the cost of the valve and the labor to install it.

Internal ID: 118

P92-18

IPC: 606.5 (New), 606.5.1 (New)

Proponent: Richard Houle, Reliance Worldwide Corporation, representing Reliance Worldwide Corporation (rich.houle@rwc.com)

2018 International Plumbing Code

Add new text as follows:

606.5 Leak detection devices. A leak detection device shall be installed after the main water shut off valve and after the pressure reducing valve, where installed. The leak detection device shall be capable of measuring water flow down to 0.25 gpm. All water contact components shall be third party certified for compliance with NSF 61 and NSF 372. Where the device includes an automatic flow control valve, the valve shall comply with one of the standards indicated in Table 605.7. The leak detection system shall include an integrated automatic notification system for alerting users of potential leaks.

606.5.1 Automatic valves in fire suppression systems. Where a fire suppression system is installed, the automatic flow control valve shall be installed after the branch to the fire suppression system. Where a multi-purpose fire suppression system is installed, an automatic flow control valve shall not be installed.

Reason:

Water leaks in homes account for a significant amount of wasted water, whether it is from a leaking toilet, dripping faucet or a breach in the plumbing system. Water damages in homes is the number 1 cause of insurance claims. A leak in a home, whether caused from a nail penetrating one of the water distribution pipes or a leaking toilet can be the source of significant damage in a home requiring mold remediation, and significant repairs to a home. By detecting potential leaks early, not only can damage be minimized but also save a significant amount of one of our most precious resources. This device can also save significant water damage when installed during construction. Breaches to the plumbing system can be identified the minute a breach is made during the construction process. A new home can be turned over to the new owners with proof that the plumbing system has not been compromised during construction.

Cost Impact

The code change proposal will increase the cost of construction .

This proposal will increase the cost of construction \$200 - - \$1500 per unit depending on the system installed. There are several different manufacturer's of this type of system. The added cost of construction is outweighed by the benefits of this type of device. Early detection saves water and significant water damage.

Internal ID: 1507

P93-18

IPC: 606.7

Proponent: Michael Cudahy, representing Plastic Pipe and Fittings Association (mikec@cmservices.com)

2018 International Plumbing Code

Delete without substitution:

~~**606.7 Labeling of water distribution pipes in bundles.** Where water distribution piping is bundled at installation, each pipe in the bundle shall be identified using stenciling or commercially available pipe labels. The identification shall indicate the pipe contents and the direction of flow in the pipe. The interval of the identification markings on the pipe shall not exceed 25 feet (7620 mm). There shall be not less than one identification label on each pipe in each room, space or story.~~

Reason:

Current text is an unnecessary mandatory practice for flexible piping system, not required for any other piping system. The piping is all water distribution piping, so why mark it so? Marking the direction of flow is also unnecessary. The stencilling is not described and the interval seems arbitrary.

Cost Impact

The code change proposal will decrease the cost of construction .

Where labeling had to be field applied, there will be a minor decrease in label materials and the labor to apply.

Internal ID: 948

P94-18

IPC: 607.1

Proponent: Duane Jonlin, representing City of Seattle (duane.jonlin@seattle.gov)

2018 International Plumbing Code

Revise as follows:

607.1 Where required. In residential *occupancies*, *hot water* shall be supplied to plumbing fixtures and equipment utilized for bathing, washing, culinary purposes, cleansing, laundry or building maintenance. In nonresidential *occupancies*, *hot water* shall be supplied for culinary purposes, cleansing, laundry or building maintenance purposes. In nonresidential *occupancies*, *hot water* or *tempered water* shall be supplied for bathing and washing purposes.

Exception: Where the water serving public lavatories that are not served by separate hot and cold water pipes is not heated, or is heated with a water heating system that is not capable of heating the water to a temperature above 80° F, this section shall not apply.

Reason:

Use of 120-degree water for handwashing increases the risk of disease transmission, as well as wasting energy and increasing the cost and complexity of construction. Room temperature water provides equal handwashing hygiene, while not supporting the growth of legionella. This proposal makes hot water optional for lavatories, and provides significant cost savings: the hot water piping, circulation pumps, pipe insulation, tempering valves, mixing valves and numerous other components would become unnecessary, and little if any water heating would be required. Operational savings and risk reduction persist for the life of the building, with dramatically decreased energy, maintenance, and equipment replacement costs, and no growth of legionella.

Owners can still provide hot water for handwashing, but this proposal allows those concerned with cost, safety and disease control to opt out if they so choose.

Bibliography:

Show Me the Science - How to Wash Your Hands, Centers for Disease Control and Prevention (2017), page 1, www.cdc.gov/handwashing/show-me-the-science-handwashing.html

The environmental cost of misinformation: why the recommendation to use elevated temperatures for handwashing is problematic, International Journal of Consumer Studies, Carrico, Amanda R., et al. (2013) page 2.

Cool Water as Effective as Hot for Removing Germs During Handwashing, Infection Control Today (2017) page 1

Water temperature as a factor in handwashing efficacy, Food Service Technology, Michaels, B, et al, (2002) pages 139-149

Cost Impact

The code change proposal will decrease the cost of construction .

This proposal makes hot water for lavatories optional.

For those who choose to provide hot water for lavatories, there is no cost change.

For those who choose not to provide hot water for lavatories, there are significant cost savings in materials, labor and space usage, due to the elimination of an entire system serving those lavatories. In addition, operational savings for energy, maintenance and equipment replacement are dramatically reduced and in some cases eliminated for the building's water heating and distribution system.

Internal ID: 1183

P95-18

IPC: 607.1

Proponent: Tim Keane, representing self (timke@verizon.net)

2018 International Plumbing Code

Revise as follows:

607.1 Where required. In residential ~~and nonresidential~~ *occupancies, hot water or tempered water* shall be supplied to plumbing fixtures and equipment utilized for bathing, washing, culinary purposes, cleansing, laundry or building maintenance. ~~In nonresidential occupancies, hot water shall be supplied for culinary purposes, cleansing, laundry or building maintenance purposes. In nonresidential occupancies, hot water or tempered water shall be supplied for bathing and washing purposes.~~

Reason:

The purpose of this code change proposal is to simplify the code by recognizing that all purposes for using heated water need the same temperatures in residential and nonresidential occupancies.

What follows is the reason statement that supports several change proposals. There is one reason statement for these proposals because the topics are interrelated and a comprehensive discussion is most likely to result in the best outcome for protecting the public's health and safety

Health and safety for public hand washing needs to include 1) scald prevention, 2) hand washing efficacy and 3) minimizing the risk of pathogen growth in the building's water distribution system.

We do not want the temperature of the water at public sinks to be too hot. We want the temperature of the water to be comfortable for the users of public sinks so that people will scrub their hands long enough to get them clean. We want to reduce the likelihood that pathogens will grow in the water distribution system. And, we would like to accomplish all of these health and safety functions in the most cost effective and sustainable manner possible.

At present, we believe that there are a few provisions in the IPC that inadvertently create a public health risk. Changing the temperature limits in this definition is one part of resolving this problem.

When the provisions in the current definitions and the related sections were first codified, Legionella was not a significant concern to public health; many items known today were unknown then. Now Legionella in building water systems has become a major concern for public health with the incidence of Legionnaires' disease growing by 500% from 0.4 cases per 100,000 people in 2000 to 2.0 cases per 100,000 people in 2015.¹

At the time these same provisions were codified, it used be thought that warm water was necessary for effective hand cleaning to control the spread of germs (bacteria). Science has since proven that the temperature of the water used for handwashing does not impact the efficacy of removing bacteria at all.^{2, 3, 4} While each of these three papers are very clear the CDC sums it up best with "The temperature of the water does not appear to affect microbe removal; however, warmer water may cause more skin irritation and is more environmentally costly"⁴ The most important variables for removing bacteria from ones hands are scrubbing and the use of soap. Neither of these criteria is within the purview of a building code.

When scald prevention was discussed as part of codifying these same provisions, the unintended consequences of lower water temperature on waterborne pathogen growth was not known. Accordingly temperature of 140°F originally proposed for scald control in home hot water heaters was lowered to 130°F and finally a recommendation of 120°F was made because if 140°F was OK it was thought that adding a huge safety margin would only be better, we now know that huge safety margin had serious and significant unintended consequences. A temperature of 120°F is considered an abundantly safe scald limit. However, setting water heaters this low results in much of the hot water distribution system being at temperatures that ideal for growing pathogens.

Since 1998 OSHA guidelines have stated that hot water should be stored at 140F and delivered at a temperature greater than 120F. In 2009, the CDC published a study documenting scalding cases resulting in hospital visits by the elderly from 2001-2006. The elderly are the highest risk population for Legionnaires' disease and one of the highest risk for scalding. They found that more than 80% of the scalding cases were due to cooking activities in the kitchen. Less than 3% (220 out of 8,620 cases) were plumbing related.¹³

We believe that it is time to use our current knowledge of these interrelated elements to improve health and safety by revising the a few of the temperature related provisions in the 2018 IPC and the 2018 IRC-P

In both the IPC and the IRC, hot water is required to be supplied to plumbing fixtures and plumbing appliances intended for bathing, washing, or culinary purposes. The 2018 IPC and IRC-P have two different maximum temperature thresholds, which some say are for scald prevention. The temperature at public hand washing sinks (lavatories), is

limited to 110°F. With the exception of bidets and emergency fixtures, which are also limited to 110°F, all other fixtures are limited to 120°F. Please see the table below.

Water Temperature Provisions in the 2018 IPC and IRC-P

Fixture	Maximum Temperature	Section
Bidet	110F (43C)	IPC 408.3 IRC P2721.2
Emergency showers and eyewash stations	110F (43C)	IPC 411.1*
Individual shower valve	120F (49C)	IPC 412.3 IRC P2708.4
Multiple (gang) showers	120F (49C)	IPC 412.4
Temperature-actuated, flow-reduction devices for individual fixture fittings	120F (49C)	IPC 412.7
Public lavatories	110F (43C)	IPC 419.5
Bath tub and whirlpool tub	120F (49C)	IPC 412.5 IRC 2713.3
Head shampoo sink faucet	120F (49C)	IPC 412.10
Footbaths and pedicure baths	120F (49C)	IPC 423.3

* The maximum temperature is not shown in this IPC section, but rather in the referenced standard. This standard also has a minimum acceptable temperature of 60F for emergency fixtures. This lower number might be useful guidance for jurisdictions with cold incoming water temperatures that want to raise the temperature of cold water for hand washing during the winter months where only cold water is supplied to public lavatory faucets.

Bidets, emergency showers and eyewash stations and public lavatories are required to have tempered water supplied through a water temperature limiting device that conforms to the appropriate ASSE, ANSI or CSA standard. The upper limit of 110°F makes sense for bidets and emergency showers. It does not make sense for hand washing at public lavatories.

If 120°F is a safe temperature for showering, bathing, head shampooing, tubs, it is equally safe for hand washing at either public or private lavatory faucets. It does not make sense that the temperature is lower for hand washing than for tub bathing. If the water temperature rises quickly to an uncomfortably hot and unsafe number it is much easier to remove ones hands from the water coming out of the faucet than it is to get out of a bathtub or to get out of the way in a shower. There is no need to have a lower temperature supplied for hand washing than for showering or bathing. In fact this public lavatory temperature code is derived from ASHRAE 90.1 energy saving code, not safety.

In our research into this issue, we found that the 110°F temperature limitation for hand washing at public lavatories comes from an energy code, ASHRAE 90.1 (1989)⁵ “Energy Standard for Buildings Except Low-Rise Residential Buildings.” Section 11.4.5.2 presents the provisions for lavatories in public facility restrooms (such as those in service stations, airports, train terminals, and convention halls). These include the requirement for low flow rates (the document preceded the 1990’s era EPACT rules concerning public lavatory faucet flow rates) and for limiting the temperature to a maximum of 110°F.

In the very high use public toilets detailed in 90.1 (1989) the sinks are used many times per hour, and the combination of low temperature and low flow does not dramatically increase the health risks from waterborne pathogens; the very high turnover rates of the water in the piping brings in new disinfectant.

However, many toilet facilities currently classified as “public” are only used sporadically. The combination of low hot water temperature, low flow rate and infrequent usage, results in a very low turnover rate which in turn means that new disinfectant enters the piping very infrequently. This condition not only provides a localized incubation chamber for Legionella but once grown can result in contaminating the rest of the hot water system.

While the idea of establishing 85-110°F as a safe range for public hand washing seemed like a good idea at the time, it turns out this range is ideal for the growth of pathogens in the building’s water distribution system. Pathogens that affect humans grow in temperatures that are found in our bodies: 85-110°F. For example, Legionella reproduces at the highest rates in the range of 85-110°F. Legionnaires’ disease, caused by Legionella growth in building water systems has become a major public health concern.

Adding to the risk due to temperature is the complexity of the internal components of the mixing valves and the lack of maintenance these valves typically receive. Such maintenance is relatively time consuming and costly and is often ignored. By way of comparison, Australian codes for health and safety purposes require these local mixing valves to be disassembled and disinfected annually^{6, 7, 8}

Conclusions and Recommendations:

If 120°F is safe enough to protect against scalding for bathing, it is safe enough for public hand washing. If this temperature is safe enough for Health Care Occupancies (IPC Section 609.3), it is safe enough for the other

occupancies covered by the IPC.

Maintaining temperatures in the range of 85-110°F that is currently required in Section 419.5 is unsafe because it provides ideal conditions for the growth of pathogens, bacteria dangerous to humans. All Legionella guidelines including OSHA 1998⁹, ASHRAE 2000¹⁰, CDC 2003¹¹, and CDC 2016¹² recommend maintaining hot water temperatures at fixtures and in hot water return lines at or above 120°F.

It is not necessary to specify the temperature range for supplying water for hand washing in public lavatories, only the maximum temperature to prevent scalding.

We recommend that the maximum safe temperature for the discharge of hot water into public hand washing sinks be raised to 120°F.

We recommend moving the break point between tempered and hot water from 110°F to 120°F.

We recommend enabling the use of cold water only, or tempered water, or both at public hand washing sinks.

Bibliography:

US Centers for Disease Control (CDC) Atlanta, GA Chart titled, "Legionnaires' Disease is on the Rise 2000-2015*" National Notifiable Diseases Surveillance System <https://www.cdc.gov/legionella/downloads/fs-legionella-clinicians.pdf>

Quantifying the Effects of Water Temperature, Soap Volume, Lather Time, and Antimicrobial Soap as Variables in the Removal of Escherichia coli ATCC 11229 from Hands Journal of Food Protection June 2017 Dane A. Jensen,¹ David R. Macinga,² David J. Shumaker,² Roberto Bellino,² James W. Arbogast,² and Donald W. Schaffner¹
<http://foodprotection.com/doi/full/10.4315/0362-028X.JFP-16-370?code=fopr-site> Above was in an article titled Cool Water as Effective as Hot for Removing Germs During Handwashing Infection Control Today May 30 2017

The environmental cost of misinformation: why the recommendation to use elevated temperatures for handwashing is problematic International Journal of Consumer Studies Volume 37, Issue 4 July 2013 Amanda R. Carrico, Micajah Spoden, Kenneth A. Wallston, Michael P. Vandenberg <http://onlinelibrary.wiley.com/doi/10.1111/ijcs.12012/abstract>

Show Me the Science - How to Wash Your Hands CDC Website <https://www.cdc.gov/handwashing/show-me-the-science-handwashing.html>

ASHRAE 90.1 (1989) "Energy Standard for Buildings Except Low-Rise Residential Buildings"

Guidelines for the Control of Legionella in Manufactured Water Systems in South Australia, 2008 revised 2013
<http://www.sahealth.sa.gov.au/wps/wcm/connect/d2f047804755f77e91f5d322c3ec38c5/LegionellaGuidelines+revised+2008/MOD=AJPERES>

Department of Health & Human Services Victoria Australia Sept 2011 "Risk management plan for Legionella Control in health and aged care facilities" <https://www2.health.vic.gov.au/about/publications/policiesandguidelines/risk-management-plan-for-legionella-control-in-health-and-aged-care-facilities>

Australian Standard. Water supply. Valves for the control of heated water supply temperatures Part 3: Requirements for field-testing, maintenance or replacement of thermostatic mixing valves, tempering valves and end-of-line temperature control devices <https://www.saiglobal.com/PDFTemp/Previews/OSH/as/as4000/4000/40323.pdf>

Occupational Safety and Health Administration (OSHA) "Technical Manual Section III: Chapter 7 Legionnaires' Disease" 1998 https://www.osha.gov/dts/osta/otm/otm_iii/otm_iii_7.html

American Society of Heating, Refrigeration and Air-Conditioning Engineers, Inc. (ASHRAE) Guideline 12 "Minimizing the Risk of Legionellosis Associated with Building Water Systems" 2000

Centers for Disease Control and Prevention (CDC) Guidelines for Environmental Infection Control in Health-Care Facilities 2003 <https://www.cdc.gov/infectioncontrol/pdf/guidelines/environmental-guidelines.pdf>

Centers for Disease Control and Prevention (CDC) Developing a Water Management Program to Reduce Legionella Growth & Spread in Buildings <https://www.cdc.gov/legionella/downloads/toolkit.pdf>

Cost Impact

The code change proposal will not increase or decrease the cost of construction.

This proposal enables the use of cold water, tempered water, or both to public hand-washing facilities. If only cold water is supplied, it will decrease construction costs by eliminating the installation of a hot water distribution system to these faucets and by eliminating the installation of the associated ASSE 1070 mixing valves, reducing or eliminating the water heater for this hot water and eliminating the mechanical space used by this piping and equipment. It will also eliminate the costs of operations and maintenance by reducing expenditures on hot water and on the maintenance of the mixing valves. In places where city cold water is above 60°F year round, allowing only cold water to be supplied to public lavatories will eliminate much if not all the hot water piping and associated equipment in many buildings. By virtue of raising the allowable maximum temperature to 120°F it will now be possible to use a master-mixing valve (ASSE 1017) for temperature control instead of installing ASSE 1070 valves at every faucet. One valve costs less than many valves. Having fewer valves also dramatically reduces operating and maintenance costs.

Internal ID: 1499

P96-18

IPC: 607.1.1, 607.1.2, Chapter 15

Proponent: Julius Ballanco, JB Engineering and Code Consulting, P.C., representing Bradley Corporation (JBEngineer@aol.com)

2018 International Plumbing Code

Revise as follows:

607.1.1 Temperature limiting means. A thermostat control for a water heater shall ~~not only~~ serve as the temperature limiting means for the purposes of complying with the requirements of this code for maximum allowable hot or tempered water delivery temperature at fixtures where the water heater complies with ASSE 1082, ASSE 1084, or ASSE 1085.

607.1.2 Tempered water temperature control. Tempered water shall be ~~supplied through a water temperature controlled by one the following:~~

1. ~~A limiting device that conforms~~ conforming to ASSE 1070/ASME A112.1070/CSA B125.70 and shall limit the tempered water to not greater than set to a maximum of 110°F (43°C).
2. A thermostatic mixing valve conforming to ASSE 1017.
3. A water heater conforming to ASSE 1082.
4. A water heater conforming to ASSE 1084.

This provision shall not supersede the requirement for protective shower valves in accordance with Section 412.3.

Add new standard(s) follows:

ASSE

ASSE International
18927 Hickory Creek Drive, Suite
220
Mokena IL 60448

1085-2018:

Performance Requirements for Water Heaters for Emergency Equipment

1084-2018:

Performance Requirements for Water Heaters used as Temperature Limiting Devices

1082-2018:

Performance Requirements for Water Heaters Used as Temperature Control Devices for Hot Water Distribution Systems.

Reason:

The restriction on the use of the water heater thermostat for regulating water temperature is based on standard water heaters. There are three new water heater standards that regulate the outlet temperature of the water heater. Hence, it is appropriate to use reference these standards as the only water heaters in which the water heater thermostat can be used to regulate the upper temperature limit.

Tempered water is a comfort requirement, as well as, a scald prevention requirement. However, comfort overrides the safety requirement since tempered water is limited to a maximum temperature of 110° F. Scalding temperatures are in excess of this temperature. Other viable means of controlling tempered water to 110° F or less are available in addition to a limiting device that complies with ASSE 1070/ASME A112.1070/CSA B125.70. The most common means of controlling tempered water is with a thermostatic mixing valve that complies with ASSE 1017.

A thermostatic mixing valve is an effective method of regulating the maximum temperature. The temperature is maintained within a few degrees depending on the flow rate. Scalding temperatures are in excess of this temperature. Other viable means of maintaining the water temperature to a maximum of 110° F are water heater meeting one of the three new water heater standards.

The three new standard for water heaters are ASSE 1082, ASSE 1084, and ASSE 1085. These water heaters are equivalent to ASSE 1017, ASSE 1070, and ASSE 1071 respectively. As such, they have the capability of providing an equivalent level of performance as the corresponding mixing valve. While a water heater complying with ASSE 1071 is designed to supply tepid water for emergency fixtures, the tepid temperature range can also meet the tempered

temperature range. Hence, an ASSE 1085 water heater is also a viable option.

Cost Impact

The code change proposal will decrease the cost of construction .

The availability of more options to achieve code compliance usually results in lower construction costs.

Analysis: A review of the standards proposed for inclusion in the code, ASSE 1085-2018, ASSE 1084-2018 and ASSE1082-2018, with regard to the ICC criteria for referenced standards (Section 3.6 of CP#28) will be posted on the ICC website on or before April 2, 2018.

Internal ID: 1156

P97-18 Part I

IPC: TABLE 608.1, 608.14.3, 608.17.2, Chapter 15

Proponent: Linda Soares, TACO COMFORT SOLUTIONS, Inc., representing Linda L. Soares (LinSoa@TacoComfort.com)

THIS IS A 2 PART CODE CHANGE PROPOSAL. PART I WILL BE HEARD BY THE IPC COMMITTEE. PART II WILL BE HEARD BY THE IRC-PLUMBING COMMITTEE. SEE THE TENTATIVE HEARING ORDERS FOR THESE COMMITTEES.

2018 International Plumbing Code

Revise as follows:

608.14.3 Backflow preventer with intermediate atmospheric vent. Backflow preventers with intermediate atmospheric vents shall conform to ASSE 1012, ~~ASSE 1081~~, or CSA B64.3. These devices shall be permitted to be installed where subject to continuous pressure conditions. The relief opening shall discharge by *air gap* and shall be prevented from being submerged.

608.17.2 Connections to boilers. The potable supply to the boiler shall be equipped with a backflow preventer with an intermediate atmospheric vent complying with ASSE 1012, ~~ASSE 1081~~, or CSA B64.3. Where conditioning chemicals are introduced into the system, the potable water connection shall be protected by an *air gap* or a reduced pressure principle backflow preventer, complying with ASSE 1013, CSA B64.4 or AWWA C511.

**TABLE 608.1
APPLICATION OF BACKFLOW PREVENTERS**

DEVICE	DEGREE OF HAZARD ^a	APPLICATION ^b	APPLICABLE STANDARDS
Backflow prevention assemblies:			
Double check backflow prevention assembly and double check fire protection backflow prevention assembly	Low hazard	Backpressure or back siphonage Sizes 3/8" - 16"	ASSE 1015, AWWA C510, CSA B64.5, CSA B64.5.1
Double check detector fire protection backflow prevention assemblies	Low hazard	Backpressure or back siphonage Sizes 2" - 16"	ASSE 1048
Pressure vacuum breaker assembly	High or low hazard	Back siphonage only Sizes 1/2" - 2"	ASSE 1020, CSA B64.1.2
Reduced pressure principle backflow prevention assembly and reduced pressure principle fire protection backflow assembly	High or low hazard	Backpressure or back siphonage Sizes 3/8" - 16"	ASSE 1013, AWWA C511, CSA B64.4, CSA B64.4.1
Reduced pressure detector fire protection backflow prevention assemblies	High or low hazard	Back siphonage or backpressure (Fire sprinkler systems)	ASSE 1047
		Sizes 1/4" - 2"	
Backflow preventer plumbing devices:			
water closet flush tanks			
Backflow preventer for carbonated beverage machines	Low hazard	Backpressure or back siphonage Sizes 1/4" - 3/8"	ASSE 1022
Backflow preventer with intermediate atmospheric vents	Low hazard	Backpressure or back siphonage Sizes 1/4" - 3/4"	ASSE 1012, CSA B64.3
<u>Backflow preventer with intermediate atmospheric vent and pressure reducing valve</u>	<u>Low hazard</u>	<u>Backpressure or back siphonage</u> <u>Sizes 1/4" - 3/4"</u>	<u>ASSE 1081</u>
Dual-check-valve-type backflow preventer	Low hazard	Backpressure or back siphonage Sizes 1/4" - 1"	ASSE 1024, CSA B64.6
Hose connection backflow preventer	High or low hazard	Low head backpressure, rated working pressure, backpressure or back siphonage Sizes 1/2" - 1"	ASME A112.21.3, ASSE 1052, CSA B64.2.1.1
Hose connection vacuum breaker	High or low hazard	Low head backpressure or back siphonage Sizes 1/2" - 1"	ASME A112.21.3, ASSE 1011, CSA B64.2

		1/2, 3/4, 1	CSA B64.2, CSA B64.2.1
Laboratory faucet backflow preventer	High or low hazard	Low head backpressure and backsiphonage	ASSE 1035, CSA B64.7
Pipe-applied atmospheric-type vacuum breaker	High or low hazard	Backsiphonage only Sizes 1/4"–4"	ASSE 1001, CSA B64.1.1
Vacuum breaker wall hydrants, frost-resistant, automatic-draining-type	High or low hazard	Low head backpressure or backsiphonage Sizes 3/4", 1"	ASME A112.21.3, ASSE 1019, CSA B64.2.2
Other means or methods:			
Air gap	High or low hazard	Backsiphonage or backpressure	ASME A112.1.2
Air gap fittings for use with plumbing fixtures, appliances and appurtenances	High or low hazard	Backsiphonage or backpressure	ASME A112.1.3
Barometric loop	High or low hazard	Backsiphonage only	(See Section 608.14.4)

For SI: 1 inch = 25.4 mm.

- a. Low hazard-See Pollution (Section 202).High hazard-See Contamination (Section 202).
- b. See Backpressure, low head (Section 202).See Backsiphonage (Section 202).

Add new standard(s) follows:

ASSE

ASSE International
18927 Hickory Creek Drive, Suite
220
Mokena IL 60448

1081-2014:

Performance Requirements for Backflow Preventers with Integral Pressure Reducing Boiler Feed Valve and Intermediate Atmospheric Vent Style for Domestic and Light Commercial Water

Analysis: A review of the standard proposed for inclusion in the code, ASSE 1081-2014, with regard to the ICC criteria for referenced standards (Section 3.6 of CP#28) will be posted on the ICC website on or before April 2, 2018.

Internal ID: 1573

P97-18 Part II

IRC: TABLE P2902.3, P2902.3.3, P2902.5.1, Chapter 44

Proponent: Linda Soares, TACO COMFORT SOLUTIONS, Inc., representing Linda L. Soares (LinSoa@TacoComfort.com)

2018 International Residential Code

Revise as follows:

P2902.3.3 Backflow preventer with intermediate atmospheric vent~~vent~~. Backflow preventers with intermediate atmospheric vents shall conform to ASSE 1012, ASSE 1081, or CSA B64.3. These devices shall be permitted to be installed where subject to continuous pressure conditions. These devices shall be prohibited as a means of protection where any hazardous chemical additives are introduced downstream of the device. The relief opening shall discharge by *air gap* and shall be prevented from being submerged.

P2902.5.1 Connections to ~~boilers~~boilers. Where chemicals will not be introduced into a boiler, the potable water supply to the boiler shall be protected from the boiler by a backflow preventer with an intermediate atmospheric vent complying with ASSE 1012, ASSE 1081, or CSA B64.3. Where chemicals will be introduced into a boiler, the potable water supply to the boiler shall be protected from the boiler by an *air gap* or a reduced pressure principle backflow prevention assembly complying with ASSE 1013, CSA B64.4 or AWWA C511.

**TABLE P2902.3
APPLICATION FOR BACKFLOW PREVENTERS**

DEVICE	DEGREE OF HAZARD^a	APPLICATION^b	APPLICABLE STANDARDS
Backflow Prevention Assemblies			
Double-check backflow prevention assembly and double-check fire protection backflow prevention assembly	Low hazard	Backpressure or backsiphonage Sizes $\frac{3}{8}$ " - 16"	ASSE 1015, AWWA C510, CSA B64.5, CSA B64.5.1
Double-check detector fire protection backflow prevention assemblies	Low hazard	Backpressure or backsiphonage Sizes 2" - 16"	ASSE 1048
Pressure vacuum breaker assembly	High or low hazard	Backsiphonage only Sizes $\frac{1}{2}$ " - 2"	ASSE 1020, CSA B64.1.2
Reduced pressure principle backflow prevention assembly and reduced pressure principle fire protection backflow prevention assembly	High or low hazard	Backpressure or backsiphonage Sizes $\frac{3}{8}$ " - 16"	ASSE 1013, AWWA C511, CSA B64.4, CSA B64.4.1
Reduced pressure detector fire protection backflow prevention assemblies	High or low hazard	Backsiphonage or backpressure (Fire sprinkler systems)	ASSE 1047
Spill-resistant vacuum breaker	High or low hazard	Backsiphonage only Sizes $\frac{1}{4}$ " - 2"	ASSE 1056, CSA B64.1.3
Backflow Preventer Plumbing Devices			
Antisiphon-type fill valves for gravity water closet flush tanks	High hazard	Backsiphonage only	ASSE 1002/ASME A112.1002/CSA B125.12, CSA B125.3
Backflow preventer with intermediate atmospheric vents	Low hazard	Backpressure or backsiphonage Sizes $\frac{1}{4}$ " - $\frac{3}{8}$ "	ASSE 1012, CSA B64.3
<u>Backflow preventer with intermediate atmospheric vents and pressure reducing valve</u>	<u>Low hazard</u>	<u>Backpressure or backsiphonage</u> <u>Sizes $\frac{1}{4}$" - $\frac{3}{4}$"</u>	<u>ASSE 1081</u>
Dual-check-valve-type backflow preventers	Low hazard	Backpressure or backsiphonage Sizes $\frac{1}{4}$ " - 1"	ASSE 1024, CSA B64.6
Hose-connection backflow preventer	High or low hazard	Low head backpressure, rated working pressure backpressure or backsiphonage Sizes $\frac{1}{2}$ " - 1"	ASSE 1052, CSA B64.2.1.1
Hose-connection vacuum breaker	High or low hazard	Low head backpressure or backsiphonage Sizes $\frac{1}{2}$ ", $\frac{3}{4}$ ", 1"	ASSE 1011, CSA B64.2, CSA B64.2.1
Laboratory faucet backflow preventer	High or low hazard	Low head backpressure and backsiphonage	ASSE 1035, CSA B64.7
Pipe-applied atmospheric-type vacuum breaker	High or low hazard	Backsiphonage only Sizes $\frac{1}{4}$ " - 4"	ASSE 1001, CSA B64.1.1
Vacuum breaker wall hydrants, frost-resistant, automatic-draining type	High or low hazard	Low head backpressure or backsiphonage Sizes $\frac{3}{4}$ " - 1"	ASSE 1019, CSA B64.2.2
Other Means Or Methods			
Air gap	High or low hazard	Backsiphonage only	ASME A112.1.2
Air gap fittings for use with plumbing fixtures, appliances and appurtenances	High or low hazard	Backsiphonage or backpressure	ASME A112.1.3

For SI: 1 inch = 25.4 mm.

- a. Low hazard-See Pollution (Section R202). High hazard-See Contamination (Section R202).
- b. See Backpressure (Section R202). See Backpressure, Low Head (Section R202). See Backsiphonage (Section R202).

Add new standard(s) follows:

ASSE

ASSE International
18927 Hickory Creek Drive, Suite
220
Mokena IL 60448
US

1081-2014:

Performance Requirements for Backflow Preventers with Integral Pressure Reducing Boiler Feed Valve and Intermediate Atmospheric Vent Style for Domestic and Light Commercial Water

Reason:

ASSE 1081 covers devices that have combined products compliant to both ASSE 1003 and ASSE 1012. These devices have different hydrodynamic needs, hence the new standard for the device. They can be used in lieu of an ASSE 1012-compliant device with respect to boiler feed applications.

Cost Impact

The code change proposal will not increase or decrease the cost of construction .

An ASSE 1081 device can be used interchangeably with an ASSE 1012 or CSA B64.3 device. Options for code compliance usually result in lower cost of construction.

Analysis: A review of the standard proposed for inclusion in the code, ASSE 1081-2014, with regard to the ICC criteria for referenced standards (Section 3.6 of CP#28) will be posted on the ICC website on or before April 2, 2018.

Internal ID: 3424

P98-18 Part I

IPC: 608.15.2.1

Proponent: Julius Ballanco, JB Engineering and Code Consulting, P.C., representing Self (JBEngineer@aol.com)

THIS IS A 2 PART CODE CHANGE PROPOSAL. PART I WILL BE HEARD BY THE IPC COMMITTEE. PART II WILL BE HEARD BY THE IRC-PLUMBING COMMITTEE. SEE THE TENTATIVE HEARING ORDERS FOR THESE COMMITTEES.

2018 International Plumbing Code

Revise as follows:

608.15.2.1 Relief port piping. The termination of the piping from the relief port or *air gap* fitting of a backflow preventer shall discharge to an *approved* indirect waste receptor or to the outdoors where it will not cause damage or create a nuisance. The indirect waste receptor and drainage piping shall be sized to drain the maximum discharge flow rate from the relief port as published by the backflow preventer manufacturer.

Internal ID: 1315

P98-18 Part II

IRC: P2902.6.3

Proponent: Julius Ballanco, JB Engineering and Code Consulting, P.C., representing Self (JBEngineer@aol.com)

2018 International Residential Code

Revise as follows:

P2902.6.3 Relief port piping. The termination of the piping from the relief port or air gap fitting of the backflow preventer shall discharge to an *approved* indirect waste receptor or to the outdoors where it will not cause damage or create a nuisance. The indirect waste receptor and drainage piping shall be sized to drain the maximum discharge flow rate from the relief port as published by the backflow preventer manufacturer.

Reason:

It is not uncommon to find in the field a 4 inch reduced pressure principle backflow preventer relief port discharging to a 2 inch floor drain. When the relief port opens at the full flow rate published by the manufacturer, the room where the backflow preventer is located will fill with water in a short period of time.

It is important that the indirect waste receptor and drain be properly sized to accommodate the maximum flow rate from a relief port. When multiple backflow preventers are located in the same room, the indirect waste receptor and drain only has to be sized for the largest backflow preventer. There is never an assumption of multiple relief ports opening at the same time. That would indicate a multiple failure scenario which is not how the Plumbing Code evaluates failures.

The manufacturers are required to publish the flow rates through the backflow preventer relief port in their specification sheets. This information is readily available. The drain can be easily sized for the discharge in the manufacturer's published data.

Cost Impact

The code change proposal will not increase or decrease the cost of construction .

The manufacturers require drainage for the discharge from the relief port. This addition reinforces the requirements already stated in the manufacturer's literature.

Internal ID: 3501

P99-18

IPC: 609.2

Proponent: Guy McMann, representing Colorado Association of Plumbing and Mechanical Officials (CAPMO)
(gcmcmann@jeffco.us)

2018 International Plumbing Code

Revise as follows:

609.2 Water service. Hospitals shall have two water service pipes installed in such a manner so as to minimize the potential for an interruption of the supply of water in the event of a water main or water service pipe failure. Each water service pipe shall enter the building independently and shall be sized in accordance with Section 603.1.

Reason:

This Section lacks some specificity and doesn't provide much guidance. The intent is to eliminate the possibility of water service interruption. There needs to be a separation distance for the two water lines that designers can employ based the the situation. No specific number has been submitted as each situation will require analysis by the designers

Cost Impact

The code change proposal will not increase or decrease the cost of construction .

This is editorial in nature and isnt requiring anything in addition to whats already required.

Internal ID: 109

P100-18

IPC: 609.2

Proponent: John Williams, Chair, representing Healthcare Committee (AHC@iccsafe.org)

2018 International Plumbing Code

Revise as follows:

609.2 Water service for Group I-2, Condition 2. ~~Hospitals Group I-2, Condition 2 facilities shall have a minimum of two water service pipes installed in such a manner so as to minimize the potential for an interruption of the supply of water in the event of a water main or water service pipe failure, sized such that with the loss of the largest service pipe, the remaining service pipes will meet the water demand for the entire facility. Each water service shall have a shut off valve in the building and a shut off valve at the utility-provided point of connection to the water main or other source of potable water.~~

Reason:

The existing language is not specific and could lead to several different required piping configurations. The proposed change provides needed clarity to the code and provides jurisdiction a reasonable means of enforcement. Existing language creates a overly burdensome requirement for hospitals on remote sites. The proposed language sets specific requirements for the service lines into the building, with directions for capacity redundancy. Also clarifies a design configuration that provides maximum flexibility in event of failure of a single service line.

This proposal is submitted by the ICC Committee on Healthcare (CHC). The CHC was established by the ICC Board to evaluate and assess contemporary code issues relating to healthcare facilities. This is a joint effort between ICC and the American Society for Healthcare Engineering (ASHE), a subsidiary of the American Hospital Association, to eliminate duplication and conflicts in healthcare regulation. In 2017 the CHC held 2 open meetings and numerous conference calls, which included members of the committees as well as any interested parties, to discuss and debate the proposed changes. Information on the CHC, including: meeting agendas; minutes; reports; resource documents; presentations; and all other materials developed in conjunction with the CHC effort can be downloaded from the CHC website at: <https://www.iccsafe.org/codes-tech-support/cs/icc-committee-on-healthcare/>.

Cost Impact

The code change proposal will not increase or decrease the cost of construction .

The existing language is ambiguous to the degree that it is difficult to understand how facilities are consistently enforcing the section. If anything the proposal reduces cost for providers and purveyors.

Internal ID: 705

P101-18

IPC: 609.2.1 (New)

Proponent: Guy McMann, representing Colorado Association of Plumbing and Mechanical Officials (CAPMO)
(gcmann@jeffco.us)

2018 International Plumbing Code

Add new text as follows:

609.2.1 Tracer. A yellow insulated copper tracer wire or a product designed for that purpose or other approved conductor shall be installed adjacent to underground nonmetallic piping serving as a water service for a hospital. Access shall be provided to the tracer wire or the tracer wire shall terminate above ground at each end of the nonmetallic piping. The tracer wire size shall be not less than 18 AWG and the wire insulation type shall be suitable for direct burial.

Reason:

It would be prudent for Hospitals to have the ability to locate their water service piping when utilizing non-metallic piping underground. This provides the ability to locate the pipes without having to excavate which can be an enormous cost savings. Locating the service pipes is critical to eliminate the possibility of damaging the pipes avoiding the usual methods of doing so.

Cost Impact

The code change proposal will increase the cost of construction .

The cost increase will be the cost of the wire itself and locating the ends of of the wire in a suitable fashon.

Internal ID: 117

P102-18

IPC: 202, 611, 611.1, 611.2, 611.3, 611.4 (New), 611.5 (New), Chapter 15

Proponent: Vincent Kent, Abendroth Water Conditioning, representing Abendroth Water Conditioning (vince@abendrothwater.com)

2018 International Plumbing Code

SECTION 202 GENERAL DEFINITIONS

Add new definition as follows:

POINT-OF-ENTRY (POE) WATER-CONDITIONING OR -TREATMENT DEVICE A water treatment device serving the water distribution system of a building for the purposes of altering, modifying, adding, or removing minerals, chemicals, contaminants, and suspended solids in the water that is distributed throughout the building. Outdoor hose bibbs are typically excluded from being served by conditioned or treated water.

POINT-OF-USE (POU) WATER-CONDITIONING OR -TREATMENT DEVICE A water treatment device installed to serve a single atmospheric outlet such as a faucet for the purposes of altering, modifying, adding, or removing any minerals, chemicals, contaminants, and suspended solids in water supplied to the outlet. POU treatment is often used to treat water only for drinking and cooking.

WATER CONDITIONING OR TREATMENT DEVICE. A point-of-use (POU) or point-of-entry (POE) original equipment appliance, appurtenance, fixture, or a combination thereof designed to treat potable water so as to alter, modify, add, or remove any minerals, chemicals, contaminants, and suspended solids contained in the source water. Example technologies include but are not limited to softeners, filters and reverse osmosis systems.

Revise as follows:

SECTION 611 ~~DRINKING-WATER-CONDITIONING or TREATMENT UNITS-DEVICES~~

~~611.1 Design-General system approvals.~~ Point-of-use reverse osmosis drinking water treatment units shall comply with NSF 58 or CSA B483.1. Drinking water treatment units shall meet the requirements of and point-of-entry water-conditioning or -treatment systems shall comply with ASSE 1087, NSF 42, NSF 44, NSF 53, NSF 55, NSF 58, NSF 62 or NSF 401 CSA 483.1.

~~611.2 Reverse osmosis systems-Drain discharge.~~ The drain discharge from a reverse osmosis drinking water treatment unit water-conditioning or -treatment device shall enter the drainage system through by means of an air gap in accordance with Table 608.16.1, a backflow prevention device in accordance with ASSE 1087, an appropriate backflow prevention device in accordance with Table 608.1, or an air gap device that meets the requirements of NSF 58, CSA B483.1 or IAPMO PS 65.
The building drainage system shall be capable of handling the additional discharge load of the water-conditioning or -treatment device.

~~611.3 Connection tubing-Plumbing connections.~~ The tubing-Pipe, tubing, and pipe fittings supplying water to and from drinking water treatment units shall be of a size and material as recommended by the manufacturer. The tubing shall comply with NSF 14, NSF 42, NSF 44, NSF 53, NSF 58 or NSF 61.a point-of-use or point-of-entry water-conditioning or -treatment device shall comply with NSF 14 or NSF 61. The interconnection tubing within a device shall comply with the requirements of NSF 14, NSF 61 or Section 611.1.

Pipe, tubing, and pipe fittings used downstream of point-of-use and point-of entry water-conditioning or -treatment devices shall be compatible with the treated water. The manufacturer's instructions shall be followed for the recommended compatible materials for pipe, tubing, and pipe fittings for the treated water. Copper tubing shall not be used for water treated by a reverse osmosis device.

Add new text as follows:

611.4 Sizing of Point-of-Entry Water-Conditioning or Treatment Devices. Third-party certified pressure loss characteristics shall be provided with all devices. The pressure loss through such devices shall be included in the pressure loss calculations of the system, and the water supply pipe and meter shall be adequately sized to provide for such a pressure loss.

611.5 Sizing of Point-of-Use Water-Conditioning or Treatment Devices. Point-of-use water-conditioning or

treatment devices that provide potable water to appliances, fittings, or appurtenances that require a minimum pressure and flow rate demand shall be sized, designed, and installed to meet the downstream appliance, fitting, or appurtenance manufacturer's specifications so as to not cause improper operation.

Add new standard(s) follows:

CHAPTER 15 REFERENCED STANDARDS

ASSE

ASSE International
18927 Hickory Creek Drive, Suite
220
Mokena IL 60448

ASSE 1087-2018:

Performance Requirements for Commercial and Food Service Water Treatment Utilizing Drinking Water

IAPMO

IAPMO Group
4755 E. Philadelphia Street
Ontario CA 91761 USA

PS 65-2002:

Material and Property Standard for Airgap Units for Water Conditioning Equipment Installation

NSF

NSF International
789 N. Dixboro Road P.O. Box
130140
Ann Arbor MI 48105

NSF/ANSI 401 - 2017:

Drinking Water Treatment Units - Emerging Compounds/Incidental Contaminants

NSF/ANSI 55 - 2017:

Ultraviolet Microbiological Water Treatment Systems

Reason:

202 - There currently are no definitions for a water treatment device, nor for point-of-use or point-of-entry treatment devices. These are generally accepted definitions.

611.0 - Changing the heading of the section to be consistent with what is used and installed in the industry today.

611.1 - These standards do not deal with design of the products, but rather the safety, structural integrity, and performance requirements. Updated language to describe the current standards for all POE and POU treatment devices. ASSE 1087 is a new standard developed to specifically address commercial water treatment equipment.

611.2 - Drain discharge applies to all treatment devices, not just reverse osmosis systems. Further, the type of backflow prevention device may be varied in order to ensure protection of the potable water supply, even though the most common ones used are air gaps and air gap devices. Finally, it is critical that the drain system be able to accept the volume of discharge from the device.

611.3 - The title "Connections" is more appropriate as there are connections both to and from a device as well as within the device. Described the appropriate standards for each of these use cases. When the connections are within a device covered by a standard, the connections need to meet the requirements of that device's standard. Also, as an example, the low pH or minimal total dissolved solids from the product water of a reverse osmosis system will cause pitting and corrosion of downstream copper tubing. Some consideration needs to be made for this when a system is designed and installed.

611.4 & 611.5 - This language is missing from section 611 as questions arise frequently in the field as to how to size a system when water conditioning and treatment units are involved. Documentation on losses is not always available which may lead to over- or under-sized systems. This is a more accurate representation of how to properly size any water distribution system, and is consistent with the existing language in Appendix E.

Cost Impact

The code change proposal will not increase or decrease the cost of construction .

These changes clarify how water conditioning and treatment products are used. The additional sections codifies information that should be given to the designer and installer anyway for proper sizing.

Analysis: A review of the standard proposed for inclusion in the code, ASSE 1087—2018, NSF 401-2017, NSF 55-2017 and IAPMO PS 65-2002 with regard to the ICC criteria for referenced standards (Section 3.6 of CP#28) will be posted on the ICC website on or before April 2, 2018.

Internal ID: 1728

P103-18 Part I

IPC: TABLE 702.3, Chapter 15

Proponent: Pennie Feehan, representing Plumbing, Mechanical, and Fuel Gas Code Action Committee
(PMGCAC@iccsafe.org)

THIS IS A 2 PART CODE CHANGE PROPOSAL. PART I WILL BE HEARD BY THE IPC COMMITTEE. PART II WILL BE HEARD BY THE IRC-PLUMBING COMMITTEE. SEE THE TENTATIVE HEARING ORDERS FOR THESE COMMITTEES.

2018 International Plumbing Code

Revise as follows:

**TABLE 702.3
BUILDING SEWER PIPE**

MATERIAL	STANDARD
Acrylonitrile butadiene styrene (ABS) plastic pipe in IPS diameters, including Schedule 40, DR 22 (PS 200) and DR 24 (PS 140); with a solid, cellular core or composite wall	ASTM D2661; ASTM D2680; ASTM F628; ASTM F1488; CSA B181.1
Acrylonitrile butadiene styrene (ABS) plastic pipe in sewer and drain diameters, including SDR 42 (PS 20), PS 35, SDR 35 (PS 45), PS 50, PS 100, PS 140, SDR 23.5 (PS 150) and PS 200; with a solid, cellular core or composite wall	ASTM F1488; ASTM D2751
Cast-iron pipe	ASTM A74; ASTM A888; CISPI 301
Concrete pipe	ASTM C14; ASTM C76; CSA A257.1M; CSA A257.2M
Copper or copper-alloy tubing (Type K or L)	ASTM B75; ASTM B88; ASTM B251
Polyethylene (PE) plastic pipe (SDR-PR)	ASTM F714
Polypropylene (PP) plastic pipe	ASTM F2736; ASTM F2764; CSA B182.13
Polyvinyl chloride (PVC) plastic pipe in IPS diameters, including Schedule 40, DR 22 (PS 200) and DR 24 (PS 140); with a solid, cellular core or composite wall	ASTM D2665; ASTM F891; ASTM F1488
Polyvinyl chloride (PVC) plastic pipe in sewer and drain diameters, including PS 25, SDR 41 (PS 28), PS 35, SDR 35 (PS	ASTM F891; ASTM F1488; ASTM D3034; CSA B182.2; CSA B182.4

46), PS 50, PS 100, SDR 26 (PS 115), PS 140 and PS 200; with a solid, cellular core or composite wall	
Polyvinyl chloride (PVC) plastic pipe with a 3.25-inch O.D. and a solid, cellular core or composite wall	ASTM D2949, ASTM F1488
Polyvinylidene fluoride (PVDF) plastic pipe	ASTM F1673; CSA B181.3
Stainless steel drainage systems, Types 304 and 316L	ASME A112.3.1
Vitrified clay pipe	ASTM C4; ASTM C700

For SI: 1 inch = 25.4 mm.

Add new standard(s) follows:

ASTM

ASTM International
100 Barr Harbor Drive, P.O. Box
C700
West Conshohocken PA 19428-
2959

D2680 - 01(2014):

**Standard Specification for Acrylonitrile-Butadiene-Styrene (ABS) and Poly(Vinyl Chloride) (PVC)
Composite Sewer Piping**

Analysis: A review of the standard proposed for inclusion in the code, ASTM D2680 - 01(2014), with regard to the ICC criteria for referenced standards (Section 3.6 of CP#28) will be posted on the ICC website on or before April 2, 2018.

Internal ID: 521

P103-18 Part II

IRC: TABLE P3002.2, Chapter 44

Proponent: Pennie Feehan, representing Plumbing, Mechanical, and Fuel Gas Code Action Committee (PMGCAC@iccsafe.org)

2018 International Residential Code

Revise as follows:

**TABLE P3002.2
BUILDING SEWER PIPE**

MATERIAL	STANDARD
Acrylonitrile butadiene styrene (ABS) plastic pipe in IPS diameters, including schedule 40, DR 22 (PS 200) and DR 24 (PS 140); with a solid, cellular core or composite wall	ASTM D2661; ASTM D2680; ASTM F628; ASTM F1488
Acrylonitrile butadiene styrene (ABS) plastic pipe in sewer and drain diameters, including SDR 42 (PS 20), PS35, SDR 35 (PS 45), PS50, PS100, PS140, SDR 23.5 (PS 150) and PS200; with a solid, cellular core or composite wall	ASTM D2751; ASTM F1488
Polyvinyl chloride (PVC) plastic pipe in sewer and drain diameters, including PS 25, SDR 41 (PS 28), PS 35, SDR 35 (PS 46), PS 50, PS 100, SDR 26 (PS 115), PS140 and PS 200; with a solid, cellular core or composite wall	ASTM D3034; ASTM F891; ASTM F1488; CSA B182.2; CSA B182.4
Cast-iron pipe	ASTM A74; ASTM A888; CISPI 301
Concrete pipe	ASTM C14; ASTM C76; CSA A257.1; CSA A257.2
Copper or copper-alloy tubing (Type K or L)	ASTM B75/B75M; ASTM B88; ASTM B251
Polyethylene (PE) plastic pipe (SDR-PR)	ASTM F714
Polyolefin pipe	ASTM F1412; CSA B181.3
Polyvinyl chloride (PVC) plastic pipe in IPS diameters, including schedule 40, DR 22 (PS 200) and DR 24 (PS 140); with solid, cellular core or composite wall	ASTM D2665; ASTM D2949; ASTM D3034; ASTM F1412; CSA B182.2; CSA B182.4
Polyvinyl chloride (PVC) plastic pipe with a 3.25 inch O.D. and a solid, cellular core or composite wall	ASTM D2949, ASTM F1488
Stainless steel drainage systems, Types 304 and 316L	ASME A112.3.1
Vitrified clay pipe	ASTM C425; ASTM C700

For SI: 1 inch = 25.4 mm.

Add new standard(s) follows:

ASTM

ASTM International
100 Barr Harbor Drive, P.O. Box
C700
West Conshohocken PA 19428
US

D2680 - 01(2014):

Standard Specification for Acrylonitrile-Butadiene-Styrene (ABS) and Poly(Vinyl Chloride) (PVC) Composite Sewer Piping

Reason:

A new standard for ABS piping is being added to increase flexibility in piping choices for building sewers.

This proposal is submitted by the ICC Plumbing/Mechanical/Gas Code Action Committee (PMG CAC). The PMG CAC was established by the ICC Board of Directors to pursue opportunities to improve and enhance the International Codes or portions thereof that were under the purview of the PMG CAC. In 2017 the PMG CAC held one face-to-face meeting and 11 conference call meetings. Numerous interested parties attended the committee meetings and offered their input.

Cost Impact

The code change proposal will not increase or decrease the cost of construction .

ABS piping is not required to be used-it is a designer or installer decision. No new materials or labor are required by this proposal thus, there is not a cost increase.

Internal ID: 3472

P104-18

IPC: 702.6, TABLE 702.6 (New), 901.3, 902.1.1 (New), Chapter 15

Proponent: Brian Helms, Charlotte Pipe and Foundry, Plastics Division, representing Charlotte Pipe and Foundry (brian.helms@charlottepipe.com)

2018 International Plumbing Code

Revise as follows:

702.6 Chemical waste drainage system. A chemical waste drainage system, including its vent system, shall be completely ~~separated independent~~ from ~~the any~~ sanitary drainage system. The pipes and fittings of a chemical waste drainage system shall conform to any of the applicable standards indicated in Table 702.6. The pipe and fitting material shall be recommended by the manufacturers of the pipe and fittings for the temperatures, types and concentrations of chemicals that the system is designed for. The drainage in a chemical waste drainage system shall be treated in accordance with Section 803.2 before discharging to the a sanitary drainage system. Separate drainage systems for chemical wastes and vent pipes shall be of an approved material that is resistant to corrosion and degradation for the concentrations of chemicals involved.

Add new text as follows:

**TABLE 702.6
CHEMICAL DRAINAGE SYSTEM PIPE AND FITTINGS**

MATERIAL	STANDARD
Chlorinated polyvinyl chloride (CPVC)	ASTM F2618
High silicon iron	ASTM A518/A518M
Polypropylene (PP)	ASTM F1412
Polyvinylidene fluoride (PVDF)	ASTM F1673
Chemical-resistance glass	ASTM C1053
Stainless steel drainage systems	ASME A112.3.1

Revise as follows:

901.3 Chemical waste ~~vent systems~~ drainage system venting. The vent system for a chemical waste drainage system shall be independent of the sanitary vent system and shall terminate separately any vent system for a sanitary drainage system. The termination of a vent system for a chemical waste drainage system shall be through the roof to the outdoors or to an air admittance valve that complies with ASSE 1049. Air admittance valves for chemical waste drainage systems shall be constructed of materials ~~approved~~ in accordance with Section 702.6 and shall be tested for chemical resistance in accordance with ASTM F1412.

Add new text as follows:

902.1.1 Chemical waste drainage system vents. The pipe and fitting materials for the vent system of a chemical waste drainage system shall be in accordance with Section 702.6. The methods utilized for construction and installation of such venting system shall be in accordance with the pipe and fitting manufacturers' instructions.

Add new standard(s) follows:

ASTM

ASTM International
100 Barr Harbor Drive, P.O. Box
C700
West Conshohocken PA 19428-
2959

F2618-15:

Standard Specification for Chlorinated Poly (Vinyl Chloride) (CPVC) Pipe and Fittings for Chemical Waste Drainage Systems

C1053-00 (2015):

Standard Specification for Borosilicate Glass Pipe and Fittings for Drain, Waste, and Vent (DWV) Applications

A518/A518M -99 (2012):

Standard Specification for Corrosion-Resistant High-Silicon Iron Castings

Reason:

Chemical waste drainage is very different from sanitary drainage applications included in Chapter 7. Chemical waste applications require pipe and fitting systems that are specifically designed to convey waste that may be harmful to other piping materials as well as the health and safety of the public. The code currently provides direction on allowable materials for sanitary drainage systems in tables 702.1, 702.2, 702.3 and 702.4 but is not as specific regarding chemical waste in 702.6.

Since the code requires chemical waste systems to be completely separated from the sanitary system in section 702.6 and provides direction on system design in section 803.2, it should also include a table to provide direction on allowable materials for these applications. Currently, section 702.6 requires an "approved" material, which by definition in Chapter 2, means that the material should be "acceptable to the code official." The removal of this statement and the addition of the proposed table will eliminate any confusion regarding appropriate materials for chemical waste drainage applications. Since there is no single piping system available that is impervious to every chemical, manufacturers recommendations regarding suitability for temperature and chemical resistance should be referenced

when choosing a material for a specific application.

Materials used for vents in these systems should exhibit the same physical characteristics regarding temperature and chemical resistance and therefore should be held to the same requirements.

This code change proposal includes all materials either currently manufactured or available in the market that are manufactured to standards specifically for corrosive or laboratory waste drainage applications.

Cost Impact

The code change proposal will not increase or decrease the cost of construction .

This code change proposal will not increase or decrease the cost of construction because it is intended to clarify allowable third party certified products appropriate for chemical waste drainage applications.

Analysis: A review of the standard proposed for inclusion in the code, ASTM F2618-15, ASTM C1053-00 (2015), and ASTM A518/A518M -99 (2012) with regard to the ICC criteria for referenced standards (Section 3.6 of CP#28) will be posted on the ICC website on or before April 2, 2018.

Internal ID: 1831

P105-18

IPC: Table 702.4, 705.2.4 (New), Chapter 15

Proponent: Brian Conner, Charlotte Pipe and Foundry, representing Charlotte Pipe and Foundry
(bconner@charlottepipe.com)

2018 International Plumbing Code

Add new text as follows:

705.2.4 Push-fit joints. Push-fit joints shall conform to ASME A112.4.4 and shall be installed in accordance with the manufacturer's instructions.

Revise as follows:

**TABLE 702.4
PIPE FITTINGS**

MATERIAL	STANDARD
Acrylonitrile butadiene styrene (ABS) plastic pipe in IPS diameters	ASTM D2661; ASTM F628; CSA B181.1; <u>ASME A112.4.4</u>
Acrylonitrile butadiene styrene (ABS) plastic pipe in sewer and drain diameters	ASTM D2751
Cast iron	ASME B16.4; ASME B16.12; ASTM A74; ASTM A888; CISPI 301
Copper or copper alloy	ASME B16.15; ASME B16.18; ASME B16.22; ASME B16.23; ASME B16.26; ASME B16.29
Glass	ASTM C1053
Gray iron and ductile iron	AWWA C110/A21.10
Polyethylene	ASTM D2683
Polyolefin	ASTM F1412; CSA B181.3
Polyvinyl chloride (PVC) plastic in IPS diameters	ASTM D2665; ASTM F1866
Polyvinyl chloride (PVC) plastic pipe in sewer and drain diameters	ASTM D3034
Polyvinyl chloride (PVC) plastic pipe with a 3.25-inch O.D.	ASTM D2949
Polyvinylidene fluoride (PVDF) plastic pipe	ASTM F1673; CSA B181.3
Stainless steel drainage systems, Types 304 and 316L	ASME A112.3.1
Steel	ASME B16.9; ASME B16.11; ASME B16.28
Vitrified clay	ASTM C700

For SI: 1 inch = 25.4 mm.

Add new standard(s) follows:

ASME

American Society of Mechanical
Engineers
Two Park Avenue
New York NY 10016-5990

A112.4.4-2017:

Plastic Push Fit Drain, Waste, and Vent (DWV) Fittings

Reason:

Adding this section along with the consensus standard for Push-fit DWV fittings will give code officials direction on inspecting push-fit fitting installations and installers direction on installing push-fit fittings.

Adding this section is consistent with 'push-fit joints" sections in chapter 6.

Cost Impact

The code change proposal will not increase or decrease the cost of construction .

Use of push-fit DWV fittings is an option. More options in the code usually result in an overall lowering of costs of construction because of increased flexibility for adapting to varying project situations.

Analysis: A review of the standard proposed for inclusion in the code, ASME A112.4.4-2017, with regard to the ICC criteria for referenced standards (Section 3.6 of CP#28) will be posted on the ICC website on or before April 2, 2018.

Internal ID: 2214

P106-18 Part I

IPC: 705.2.4 (New), TABLE 702.4, Chapter 15

Proponent: Angel Guzman Rodriguez, ASME, representing The American Society of Mechanical Engineers (ASME)

THIS IS A 2 PART CODE CHANGE PROPOSAL. PART I WILL BE HEARD BY THE IPC COMMITTEE. PART II WILL BE HEARD BY THE IRC-PLUMBING COMMITTEE. SEE THE TENTATIVE HEARING ORDERS FOR THESE COMMITTEES.

2018 International Plumbing Code

Add new text as follows:

705.2.4 Push-fit joints. Push-fit joints shall conform to ASME A112.4.4 and shall be installed in accordance with the manufacturer's instructions.

Revise as follows:

**TABLE 702.4
PIPE FITTINGS**

	MATERIAL	STANDARD
	Acrylonitrile butadiene styrene (ABS) plastic pipe in IPS diameters	ASTM D2661; ASTM F628; CSA B181.1; <u>ASME A112.4.4</u>
	Acrylonitrile butadiene styrene (ABS) plastic pipe in sewer and drain diameters	ASTM D2751
	Cast iron	ASME B16.4; ASME B16.12; ASTM A74; ASTM A888; CISPI 301
	Copper or copper alloy	ASME B16.15; ASME B16.18; ASME B16.22; ASME B16.23; ASME B16.26; ASME B16.29
	Glass	ASTM C1053
	Gray iron and ductile iron	AWWA C110/A21.10
	Polyethylene	ASTM D2683
	Polyolefin	ASTM F1412; CSA B181.3
	Polyvinyl chloride (PVC) plastic in IPS diameters	ASTM D2665; ASTM F1866
	Polyvinyl chloride (PVC) plastic pipe in sewer and drain diameters	ASTM D3034
	Polyvinyl chloride (PVC) plastic pipe with a 3.25-inch O.D.	ASTM D2949
	Polyvinylidene fluoride (PVDF) plastic pipe	ASTM F1673; CSA B181.3
	Stainless steel drainage systems, Types 304 and 316L	ASME A112.3.1
	Steel	ASME B16.9; ASME B16.11; ASME B16.28
	Vitrified clay	ASTM C700

For SI: 1 inch = 25.4 mm.

Add new standard(s) follows:

ASME

American Society of Mechanical
Engineers
Two Park Avenue
New York NY 10016-5990

A112.4.4-2017:

Plastic Push Fit Drain, Waste, and Vent (DWV) Fittings

Analysis: A review of the standard proposed for inclusion in the code, ASME A112.4.4-2017 , with regard to the ICC criteria for referenced standards (Section 3.6 of CP#28) will be posted on the ICC website on or before April 2, 2018.

Internal ID: 1418

P106-18 Part II

IRC: P3003.3.4 (New), TABLE P3002.3, Chapter 44

Proponent: Angel Guzman Rodriguez, ASME, representing The American Society of Mechanical Engineers (ASME)

2018 International Residential Code

Add new text as follows:

P3003.3.4 Push-fit joints. Push-fit joints shall conform to ASME A112.4.4 and shall be installed in accordance with the manufacturer's instructions.

Revise as follows:

**TABLE P3002.3
PIPE FITTINGS**

PIPE MATERIAL	FITTING STANDARD
Acrylonitrile butadiene styrene (ABS) plastic pipe in IPS diameters	ASTM D2661; ASTM D3311; ASTM F628; CSA B181.1; ASME A112.4.4
Acrylonitrile butadiene styrene (ABS) plastic pipe in sewer and drain diameters	ASTM D2751
Cast-iron	ASME B16.4; ASME B16.12; ASTM A74; ASTM A888; CISPI 301
Copper or copper alloy	ASME B16.15; ASME B16.18; ASME B16.22; ASME B16.23; ASME B16.26; ASME B16.29
Gray iron and ductile iron	AWWA C110/A21.10
Polyethylene	ASTM D2683
Polyolefin	ASTM F1412; CSA B181.3
Polyvinyl chloride (PVC) plastic in IPS diameters	ASTM D2665; ASTM D3311; ASTM F1866
Polyvinyl chloride (PVC) plastic pipe in sewer and drain diameters	ASTM D3034
Polyvinyl chloride (PVC) plastic pipe with a 3.25 inch O.D.	ASTM D2949
PVC fabricated fittings	ASTM F1866
Stainless steel drainage systems, Types 304 and 316L	ASME A112.3.1
Vitrified clay	ASTM C700

For SI: 1 inch = 25.4 mm.

Add new standard(s) follows:

ASME

American Society of Mechanical
Engineers
Two Park Avenue
New York NY 10016-5990

A112.4.4-2017:

Plastic Push Fit Drain, Waste, and Vent (DWV) Fittings

Reason:

A new standard has been published for push fit fittings to be used in DWV applications. Fittings are to be used with ABS or PVC pipe only in non-pressure applications.

Cost Impact

The code change proposal will not increase or decrease the cost of construction .

This proposal is only adding an optional type fitting that can be used for joining ABS pipe.

A review of the standard proposed for inclusion in the code, ASME A112.4.4-2017, with regard to the ICC criteria for referenced standards (Section 3.6 of CP#28) will be posted on the ICC website on or before April 2, 2018.

Internal ID: 1458

P107-18

IPC: 705.3.3.1 (New)

Proponent: Richard Houle, Reliance Worldwide Corporation, representing Reliance Worldwide Corporation (rich.houle@rwc.com)

THIS IS A 2 PART CODE CHANGE PROPOSAL. PART I WILL BE HEARD BY THE IPC COMMITTEE. PART II WILL BE HEARD BY THE IRC-PLUMBING COMMITTEE. SEE THE TENTATIVE HEARING ORDERS FOR THESE COMMITTEES.

2018 International Plumbing Code

Add new text as follows:

705.3.3.1 Restraint of hubless joints. Hubless joints shall be restrained to withstand a thrust force associated with 40 feet of water head pressure (17.3 psi) (119.6 kPa) in accordance with CISPI 301 or CISPI 310. Restraint systems shall be third party certified to this requirement. Such restraints shall be installed in accordance with manufacturer's instructions.

Reason:

This proposal brings forward the language currently included in Chapter 3 with the addition of a prescriptive requirement that is not currently included in the CISPI 301 and 310 standards, The Thrust Force Tables are included but no specific requirements for the restraint systems to meet. This proposal also includes the third party certification requirement for restraint systems. Manufactures of the hubless system currently support the installation of these systems to be in accordance with CISPI 301 and CISPI 310. This proposal would ensure that all systems would be installed uniformly throughout the US.

Cost Impact

The code change proposal will not increase or decrease the cost of construction .

This proposal is clarifying the code language already included in the code. It brings language forward from Section 303.5.

Internal ID: 1509

P108-18

IPC: Table 702.4, 705.10.4 (New), Chapter 15

Proponent: Brian Conner, representing Charlotte Pipe and Foundry (bconner@charlottepipe.com)

2018 International Plumbing Code

Add new text as follows:

705.10.4 Push-fit joints. Push-fit joints shall conform to ASME A112.4.4 and shall be installed in accordance with the manufacturer's instructions.

Revise as follows:

**TABLE 702.4
PIPE FITTINGS**

MATERIAL	STANDARD
Acrylonitrile butadiene styrene (ABS) plastic pipe in IPS diameters	ASTM D2661; ASTM F628; CSA B181.1
Acrylonitrile butadiene styrene (ABS) plastic pipe in sewer and drain diameters	ASTM D2751
Cast iron	ASME B16.4; ASME B16.12; ASTM A74; ASTM A888; CISPI 301
Copper or copper alloy	ASME B16.15; ASME B16.18; ASME B16.22; ASME B16.23; ASME B16.26; ASME B16.29
Glass	ASTM C1053
Gray iron and ductile iron	AWWA C110/A21.10
Polyethylene	ASTM D2683
Polyolefin	ASTM F1412; CSA B181.3
Polyvinyl chloride (PVC) plastic in IPS diameters	ASTM D2665; ASTM F1866; <u>ASME A112.4.4</u>
Polyvinyl chloride (PVC) plastic pipe in sewer and drain diameters	ASTM D3034
Polyvinyl chloride (PVC) plastic pipe with a 3.25-inch O.D.	ASTM D2949
Polyvinylidene fluoride (PVDF) plastic pipe	ASTM F1673; CSA B181.3
Stainless steel drainage systems, Types 304 and 316L	ASME A112.3.1
Steel	ASME B16.9; ASME B16.11; ASME B16.28
Vitrified clay	ASTM C700

For SI: 1 inch = 25.4 mm.

Add new standard(s) follows:

ASME

American Society of Mechanical
Engineers
Two Park Avenue
New York NY 10016-5990

A112.4.4-2017:

Plastic Push Fit Drain, Waste, and Vent (DWV) Fittings

Reason:

Use of push-fit DWV fittings is an option. More options in the code usually result in an overall lowering of costs of construction because of increased flexibility for adapting to varying project situations.

Cost Impact

The code change proposal will not increase or decrease the cost of construction .

Use of push-fit DWV fittings is an option. More options in the code usually result in an overall lowering of costs of construction because of increased flexibility for adapting to varying project situations.

Analysis: A review of the standard proposed for inclusion in the code, ASME A112.4.4-2017, with regard to the ICC criteria for referenced standards (Section 3.6 of CP#28) will be posted on the ICC website on or before April 2, 2018.

Internal ID: 2223

P109-18 Part I

IPC: TABLE 702.4, 705.10.4 (New), Chapter 15

Proponent: Angel Guzman Rodriguez, ASME, representing The American Society of Mechanical Engineers (ASME)

THIS IS A 2 PART CODE CHANGE PROPOSAL. PART I WILL BE HEARD BY THE IPC COMMITTEE. PART II WILL BE HEARD BY THE IRC-PLUMBING COMMITTEE. SEE THE TENTATIVE HEARING ORDERS FOR THESE COMMITTEES.

2018 International Plumbing Code

Add new text as follows:

705.10.4 Push-fit joints. Push-fit joints shall conform to ASME A112.4.4 and shall be installed in accordance with the manufacturer's instructions.

Revise as follows:

**TABLE 702.4
PIPE FITTINGS**

MATERIAL	STANDARD
Acrylonitrile butadiene styrene (ABS) plastic pipe in IPS diameters	ASTM D2661; ASTM F628; CSA B181.1
Acrylonitrile butadiene styrene (ABS) plastic pipe in sewer and drain diameters	ASTM D2751
Cast iron	ASME B16.4; ASME B16.12; ASTM A74; ASTM A888; CISPI 301
Copper or copper alloy	ASME B16.15; ASME B16.18; ASME B16.22; ASME B16.23; ASME B16.26; ASME B16.29
Glass	ASTM C1053
Gray iron and ductile iron	AWWA C110/A21.10
Polyethylene	ASTM D2683
Polyolefin	ASTM F1412; CSA B181.3
Polyvinyl chloride (PVC) plastic in IPS diameters	ASTM D2665; ASTM F1866; <u>ASME A112.4.4</u>
Polyvinyl chloride (PVC) plastic pipe in sewer and drain diameters	ASTM D3034
Polyvinyl chloride (PVC) plastic pipe with a 3.25-inch O.D.	ASTM D2949
Polyvinylidene fluoride (PVDF) plastic pipe	ASTM F1673; CSA B181.3
Stainless steel drainage systems, Types 304 and 316L	ASME A112.3.1
Steel	ASME B16.9; ASME B16.11; ASME B16.28
Vitrified clay	ASTM C700

For SI: 1 inch = 25.4 mm.

Add new standard(s) follows:

ASME

American Society of Mechanical
Engineers
Two Park Avenue
New York NY 10016-5990

A112.4.4-2017:

Plastic Push Fit Drain, Waste, and Vent (DWV) Fittings

Analysis: A review of the standard proposed for inclusion in the code, ASME A112.4.4-2017, with regard to the ICC criteria for referenced standards (Section 3.6 of CP#28) will be posted on the ICC website on or before April 2, 2018.

Internal ID: 1423

P109-18 Part II

IRC: P3003.9.4 (New), TABLE P3002.3, Chapter 44

Proponent: Angel Guzman Rodriguez, ASME, representing The American Society of Mechanical Engineers (ASME)

2018 International Residential Code

Add new text as follows:

P3003.9.4 Push-fit joints. Push-fit joints shall conform to ASME A112.4.4 and shall be installed in accordance with the manufacturer's instructions.

Revise as follows:

**TABLE P3002.3
PIPE FITTINGS**

PIPE MATERIAL	FITTING STANDARD
Acrylonitrile butadiene styrene (ABS) plastic pipe in IPS diameters	ASTM D2661; ASTM D3311; ASTM F628; CSA B181.1
Acrylonitrile butadiene styrene (ABS) plastic pipe in sewer and drain diameters	ASTM D2751
Cast-iron	ASME B16.4; ASME B16.12; ASTM A74; ASTM A888; CISPI 301
Copper or copper alloy	ASME B16.15; ASME B16.18; ASME B16.22; ASME B16.23; ASME B16.26; ASME B16.29
Gray iron and ductile iron	AWWA C110/A21.10
Polyethylene	ASTM D2683
Polyolefin	ASTM F1412; CSA B181.3
Polyvinyl chloride (PVC) plastic in IPS diameters	ASTM D2665; ASTM D3311; ASTM F1866; <u>ASME A112.4.4</u>
Polyvinyl chloride (PVC) plastic pipe in sewer and drain diameters	ASTM D3034
Polyvinyl chloride (PVC) plastic pipe with a 3.25 inch O.D.	ASTM D2949
PVC fabricated fittings	ASTM F1866
Stainless steel drainage systems, Types 304 and 316L	ASME A112.3.1
Vitrified clay	ASTM C700

For SI: 1 inch = 25.4 mm.

Add new standard(s) follows:

ASME

American Society of Mechanical
Engineers
Two Park Avenue
New York NY 10016-5990

A112.4.4-2017:

Plastic Push Fit Drain, Waste, and Vent (DWV) Fittings

Reason:

A new standard has been published for push fit fittings to be used in DWV applications. Fittings are to be used with ABS or PVC pipe only in non-pressure applications.

Cost Impact

The code change proposal will not increase or decrease the cost of construction .

This proposal is only adding an optional type fitting that can be used for joining PVC pipe.

A review of the standard proposed for inclusion in the code, ASME A112.4.4-2017, with regard to the ICC criteria for referenced standards (Section 3.6 of CP#28) will be posted on the ICC website on or before April 2, 2018.

Internal ID: 1459

P110-18

IPC: 706.3, TABLE 706.3

Proponent: Ronald George, Plumb-Tech Design & Consulting Services LLC, representing Self (Ron@Plumb-TechLLC.com)

2018 International Plumbing Code

Revise as follows:

706.3 Installation of fittings. Fittings shall be installed to guide sewage and waste in the direction of flow. Change in direction shall be made by fittings installed in accordance with Table 706.3. Change in direction by combination fittings, side inlets or increasers shall be installed in accordance with Table 706.3 based on the pattern of flow created by the fitting. Horizontal building drains shall have all branch connections rolled up as close to the building drain connection as possible so that the invert elevation of the branch connection is at least as high as the centerline of the building drain at the point of connection. Double sanitary tee patterns shall not receive the discharge of back-to-back water closets and fixtures or appliances with pumping action discharge.

Exception: Back-to-back water closet connections to double sanitary tees shall be permitted where the horizontal *developed length* between the outlet of the water closet and the connection to the double sanitary tee pattern is 18 inches (457 mm) or greater.

**TABLE 706.3
FITTINGS FOR CHANGE IN DIRECTION**

TYPE OF FITTING PATTERN	CHANGE IN DIRECTION		
	Horizontal to vertical	Vertical to horizontal	Horizontal to horizontal
Sixteenth bend	X	X	X
Eighth bend	X	X	X
Sixth bend	X	X	X
Quarter bend	X	X ^a	X ^a
Short sweep	X	X ^{a,b}	X ^a
Long sweep	X	X	X
Sanitary tee	X ^c	—	—
Wye	X	X	X ^d
Combination wye and eighth bend	X	X	X ^d

For SI: 1 inch = 25.4 mm.

- a. The fittings shall only be permitted for a 2-inch or smaller fixture drain.
- b. Three inches or larger.
- c. For a limitation on double sanitary tees, see Section ~~706.3~~ 706.3
- d. Rolled up to above the centerline of the downstream horizontal drain where connected to the horizontal building drain.

Reason:

This code change is necessary in order to maintain the hydraulic depth of flow in the main building drain and to prohibit waste from flowing back into building drain branches from the main building drain flow which causes a loss in the hydraulic depth of flow in the main building drain each time a water line flows past a branch drain and some of the mainline waste flows into to horizontal branches.

Excerpt fro an Article in Plumbing Engineer Magazine:

Energy and Water Savings Mandates are Contributing "Dry-Drains"

In 1992, the federal Energy Policy Act, was passed, and has since undergone various amendments. The broad focus of this law is to increase clean energy use and improve overall energy efficiency in the United States. Mandates for the reduction of water usage by residential and commercial users were included in this law based upon the understanding that the production and distribution of water requires energy. The law sets minimum efficiency standards for flow rates for water closets, urinals, faucets and showerheads, (except emergency fixture showerheads) that are distributed in commerce for personal use or commercial use or consumption.

The minimum efficiency standards for water closets, urinals faucets and showerheads set forth in the 1992 Energy Policy Act, section 123, are covered in in Title 42 USC section 6295(j) and , 6295 (k).

42 USC section 6295(k)(1)(A) Except as provided in subparagraph (B), the maximum water use allowed in gallons per flush for any of the following water closets manufactured after January 1, 1994, is the following:

Gravity tank-type toilets	1.6 gpf.
Flushometer tank toilets	1.6 gpf.
Electromechanical hydraulic toilets	1.6 gpf.
Blowout toilets	3.5 gpf.

42 USC section 6295(k)(1)(B)

The maximum water use allowed for any gravity tank-type white 2-piece toilet which bears an adhesive label conspicuous upon installation consisting of the words "Commercial Use Only" manufactured after January 1, 1994, and before January 1, 1997, is 3.5 gallons per flush.

42 USC section 6295(k)(1)(C)

The maximum water use allowed for flushometer valve toilets, other than blowout toilets, manufactured after January 1, 1997, is 1.6 gallons per flush.

42 USC section 6295(k)(2)

The maximum water use allowed for any urinal manufactured after January 1, 1994, is 1.0 gallon per flush.

There are similar maximum flow requirements for faucets and showers in section (j). These flow rate reductions have led to an increased the number of drainline transport problems for older plumbing systems when they were combined with poorly designed and poorly performing plumbing fixtures at the time. Manufacturers had to spend great sums of money to redesign water closets to flush with better performance. We are approaching the point where manufacturers cannot make many more improvements to plumbing fixture performance at these very low flow rates. There is a minimum amount of water required to maintain a hydraulic depth of flow in a drain and for drains to flow and perform properly. When low-flow plumbing fixtures are installed on older plumbing systems that have existing larger drains installed at the minimum slope, the lower flows create a lower hydraulic depth of flow in the drain and solids will do not transport down the drain as well. They tend to pile up and form a dam over time. The dam creates a pond in from of the dam where flow velocities are interrupted allowing solids to settle out in the pond that is formed in the drain pipe. Over a period of time, the solids plug up the existing oversized drain lines. This necessitates a call for a drain cleaning service technician.

Many of us may have heard about problems in drains and sewers following the advent of the 1992 Energy Policy Act and the mandated water flow reductions. Since then, the plumbing product manufacturers have invested a lot of money redesigning their fixtures to perform better at lower flows, however there is a limit to the possible

improvements with respect to performance. The Plumbing Industry Research Coalition (PERC) was formed and has been doing research to learn more about the drainline transport issues using low-flow fixtures. Their funding has been limited, and more research is needed, to address issues with flushable wipes, flushable toilet seat covers, and feminine products in the drain line. The research they have provided so far has been valuable with respect to understanding the limitations of plumbing fixtures and drain line transport at lower flow rates. For information on the PERC research see the following website: <http://www.plumbingefficiencyresearchcoalition.org/> (Phase 1, Phase 2 and Phase 2.1).

Studies by two engineers, Bill Gauley and John Koeller, show when various models of 1.6 and 1.28 Gallon per flush GPF water closet's were tested, tests showed drainline transport of solids is generally less in 1.28 GPF water closets when compared to 1.6 GPF water closets. There was a reduction in the drainline transport of about at 37 percent when reducing flows from 1.6 to 1.28 GPF. The transport distance was reduced from 36 feet on average to about 23 feet on average. (See Figure 4). With even lower flows being proposed, it will be difficult if not impossible for larger horizontal drainage systems to transport solids. Drain blockages will become more common at lower flow rates. In high-rise vertical buildings, it should be relatively easy to transport the waste a short distance to a vertical stack if the stack is within about 15 feet of the fixtures. There should be enough additional uses of water in the stack in a high-rise building to provide sufficient drainline transport at the lowest level in the horizontal building drain.

In a remote restroom in a large horizontal building, with no other branches providing drainage flow, there will be drainline transport problems and an increase in drainline blockages. The energy expended after cleaning up after a sewage back-ups could easily exceed the cost associated with having an adequate drain flow in the original system design. When you consider the energy and expenses associated with:

Cleaning the drain lines,

Removing moldy drywall and finishes

Repairing damage to the building

Healthcare costs associated with the spread of disease, bacteria and mold

The small amount of energy and water that may be saved will be offset by far with remediation costs. Another consideration that I have experienced is, when people realize the drains block-up on a regular basis because of inadequate flow, people will be trained to flush twice or three times to ensure the waste goes down the drain. I have seen signs in many restrooms asking users to flush multiple times if there are solids in the bowl. There is a minimum sustainable drainline flow rate and more research is needed to understand these limitations before we arbitrarily pick lower flow rates in order to gain points for an energy and environmental, water conservation program.

Figure 7c: 4" Pipe, 1% Slope, Minimum Drop Height

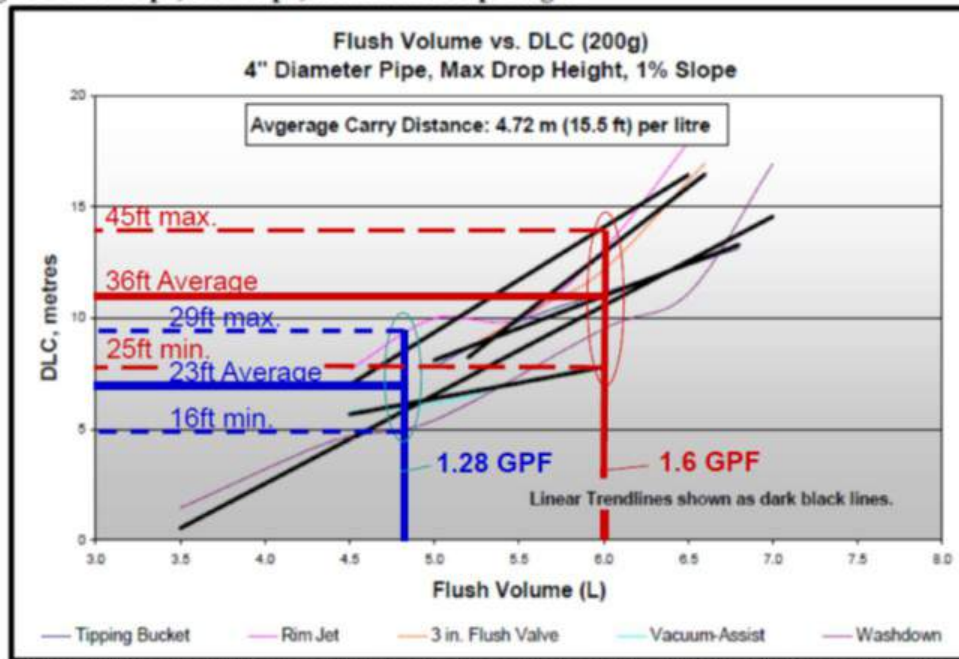

Figure 4 - Illustration Showing Drainline Transport Distance at various flow rates

Source: Evaluation of Low-Flush-Volume Toilet Technologies to Carry Waste in Drainlines, February 2005, by: Bill Gauley, P.Eng., and John Koeller, P.E.

The 'Dry Drains' Phenomenon

Dry drains is a phenomenon being brought about because of aggressive energy and water conservation efforts. Energy and water conservation code changes continue to be proposed for further reductions of water consumption for

plumbing fixtures beyond the requirements in the Energy Policy Act of 1992. These water flow reduction proposals are what I have referred to in the past as the “water conservation limbo. How low can we go?” Using the Manning Formula, and from various drainage research that is available, we have a basic understanding of the minimum flow required for each pipe size and pipe slope for various drain loadings. Despite this available knowledge, people still propose code change submittals based on simple math of water savings based on a lower flow over a fixture use period. There is no consideration of the impact on other parts of the plumbing system. Many code change proposals don't consider the laws of physics. Many code changes seem to be on the edge of violating or maybe violate the laws of physics. However, plumbing systems should perform properly with health and safety being more important than energy and water conservation. The International code change process has a button to click that asks if the proposed code change will add cost to building construction. I would like to see a button that asks: Will this code change potentially cause a decrease in system performance? I would also like to see a button for: Will this code change cause a health and Safety Issue? Code changes should be provided with technical support and research that shows no adverse effect on system performance, and the health and safety issues. The problem is complex and a simple request to save water comes with many other performance and health & safety ramifications that are not always contemplated by code change proponents with the good intentions of saving water.

Drain flows are getting to the point where the flows are insufficient to transport solids down the drain. If drain flows are reduced, and the drain pipes are the same size, then the hydraulic depth of flow will be less. In older buildings, there will likely be more problems than in newer buildings that can be designed with smaller drains with more slope.

To compound the issue, when a greywater reuse system collects discharged water from fixtures for reuse to flush water closets or for sub-surface irrigation purposes, it is taking water away from the sanitary drainage system. (See Figure 4). The wastewater flow needs to be maintained at a level to keep the hydraulic depth of flow sufficient for proper water velocities and drain line transport.

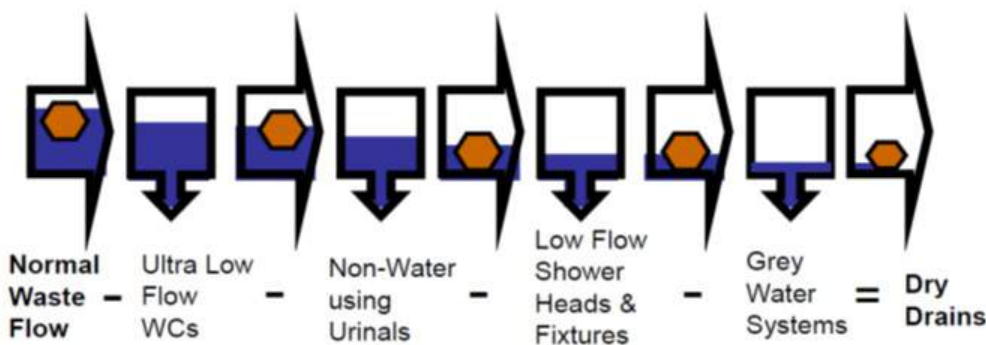

Figure 5 - Illustration showing Less Water in Drains Due to Water Conservation

Loss of Hydraulic Depth in Building Drains from Flow into Horizontal Branch Drains

There has been research done in Australia that was reported on at the Dry Drains conference that addressed flows in horizontal building drains with horizontal branch connections. The study showed when building drain branches are connected horizontally to the building drain, they allow waste to divert or back-up into each branch as the waste flows by each branch. This lowers the hydraulic depth of flow in the main. (See Figure's 5, 6 & 7) This illustrates the need to consider code requirements to roll up branches up on a 45-degree angle to prevent the waste from entering the branches (and further reducing the drainline transport capacity for drains that are already at or near minimum flow rates for proper drainline transport for ultra-low flow fixtures).

The research also confirmed a drain should not drop from directly overhead into a horizontal drain. Waste usually would be directed upstream from a vertical stack dropping into a horizontal drain. This allowed solids to settle in the horizontal pipe upstream of the connection

and reduced the hydraulic depth of flow because of the diversion of waste. The stack should use a 45 and a Y fitting rolled to allow a rolled up 45-degree entry into the horizontal drain.

Some of these are already required in our codes. We should also be more aware of using directional drainage pattern fittings as water closet flow rates are further reduced. An interesting thing of note is the fact that the minimum slope in Australia is 1.67 percent and in the U.S., the minimum slope is 1.0104 percent (1/8 inch per foot) because they generally use smaller drain pipes.

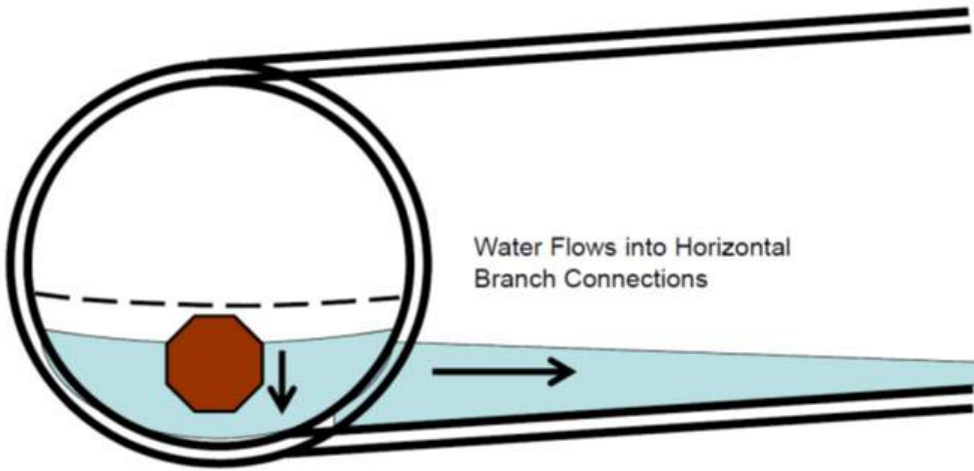

Figure 6 - Less Water in Drains Due to flow into Horizontal Branch Connections

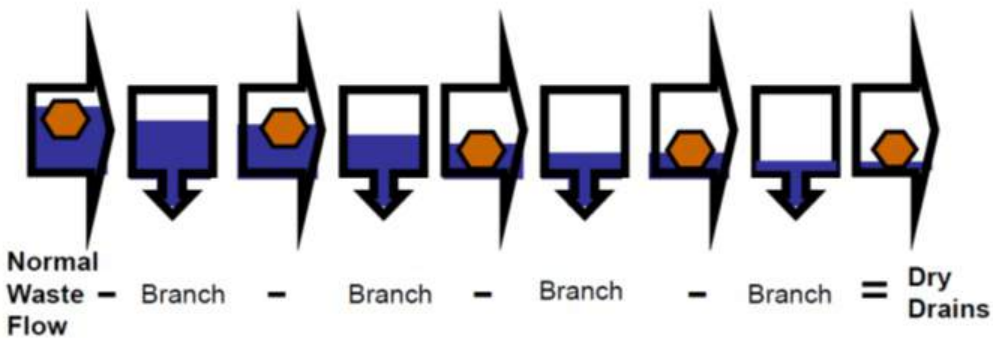

Figure 7 - Less Water in Drains Due to flow into Multiple Horizontal Branch Connections

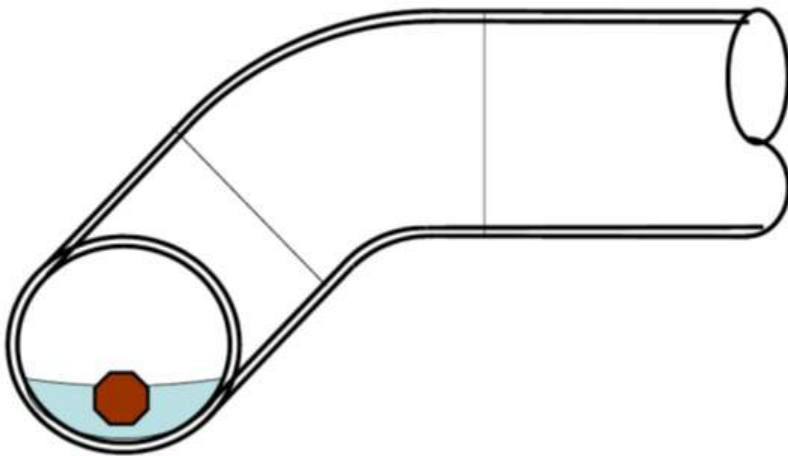

Figure 8 - Rolled Up Branch Drain to Assist with Transport of Solids.

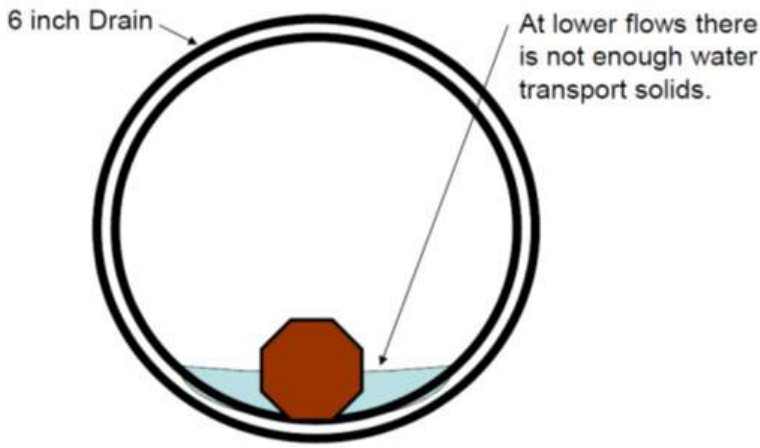

Figure 9 - Large Pipe with Low Flow Fixtures = Low hydraulic depth and Drainline Transport Problems

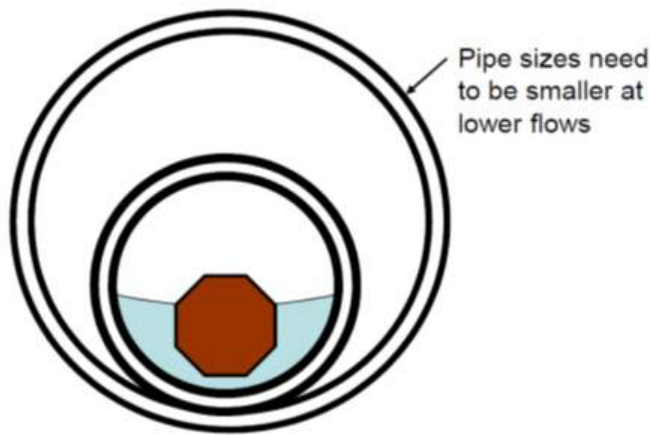

Figure 10 - Small Pipe with Low Flow Fixtures = Good Hydraulic Depth and Drainline Transport (Smaller pipes may require increased slope)

As a member of a water utility, we were experiencing water quality problems at the ends of the water distribution network because of aging water. We were also dealing with blockages in the sewer mains because there was not enough flow in the sewers. We ended up flushing fire hydrants every couple of weeks and directing the flow into sewer manholes to address the water quality and simultaneously flushing the sewers. How is this accounted for in the energy and water conservation calculations? Sadly it is not. We need to determine what the minimum flows are in order to maintain safe and properly performing plumbing systems.

I am hoping the water quality studies associated with water conservation programs at Drexel University and Purdue University look at these issues. Dumping water to keep water treatment chemical residuals up and low flow fixtures contributing to drain line transport issues seems counter-productive if we continue to make cuts in water use without knowing what are the minimum sustainable flows for each pipe size.

Ron George, CPD is president of Plumb-Tech Design & Consulting Services he has over 40 years' experience designing plumbing systems.

Cost Impact

The code change proposal will increase the cost of construction .

This code change will only address branch connections to the building drain. It is needed for health and safety.

Internal ID: 2181

P111-18

IPC: 706, 706.3 (New), 706.3, Table 706.3, 706.3.2 (New), 706.3.3 (New), 706.34 (New)

Proponent: James Richardson Jr, representing City of Columbus Ohio (jarichardson@columbus.gov); Robert Schutz, representing City of Columbus, OH (RJSchutz@columbus.gov)

2018 International Plumbing Code

Revise as follows:

SECTION 706 CONNECTIONS BETWEEN DRAINAGE PIPING AND FITTINGS SYSTEMS

Add new text as follows:

706.3 Installation. Drainage systems shall be installed in accordance with 706.3.1 thru 706.3.4.

Revise as follows:

~~**706.3**~~**706.3.1 Installation of fittings.**~~**Fittings.**~~ Fittings shall be installed to guide sewage and waste in the direction of flow. Change in direction shall be made by fittings installed in accordance with Table 706.3. Change in direction by combination fittings, side inlets or increasers shall be installed in accordance with Table ~~706.3~~706.3.1 based on the pattern of flow created by the fitting. ~~Double sanitary tee patterns shall not receive the discharge of back-to-back water closets and fixtures or appliances with pumping action discharge.~~

~~**Exception:** Back-to-back water closet connections to double sanitary tees shall be permitted where the horizontal *developed length* between the outlet of the water closet and the connection to the double sanitary tee pattern is 18 inches (457 mm) or greater.~~

**TABLE 706.3-706.3.1
FITTINGS FOR CHANGE IN DIRECTION**

TYPE OF FITTING PATTERN	CHANGE IN DIRECTION		
	Horizontal to vertical	Vertical to horizontal	Horizontal to horizontal
Sixteenth bend	X	X	X
Eighth bend	X	X	X
Sixth bend	X	X	X
Quarter bend	X	X ^a	X ^a
Short sweep	X	X ^{a,b}	X ^a
Long sweep	X	X	X
Sanitary tee	X ^e	—	—
Wye	X	X	X
Combination wye and eighth bend	X	X	X

For SI: 1 inch = 25.4 mm.

- a. The fittings shall only be permitted for a 2-inch or smaller fixture drain.
- b. Three inches ~~or~~ larger.
- c. ~~For a limitation on double sanitary tees, see Section 706.3.~~

Add new text as follows:

706.3.2 Fixture drains. ~~Fixture drains shall discharge to a horizontal branch drain, stack or building drain.~~

706.3.3 Branch drains. ~~Branch drains, horizontal or vertical, shall discharge to a stack or a building drain.~~

706.3.4 Building drain. ~~Building drains shall discharge to a building sewer.~~

Reason:

We have been witnessing a decline in the understanding of good plumbing practices. Unfortunately, many do not seem to understand that the base knowledge for the code is derived from the definitions. The definitions in the codes are the most important item in the code to understand, for without a clear understanding of the definitions you could not reasonably understand the intent of the code sections. This is the reason when a word included in the definitions is used in the code text, it is **italicized**. This provides a clear road sign back so people will refer back to the definition when developing their interpretation of the code.

Unfortunately this doesn't seem to be happening like it should. From my experience many jurisdictions will adopt some form of the ICC Building Codes, though many will also amend the code based on local submissions or adopted legislation (including my own). For my State, this has resulted in the "road signs" disappearing because someone felt it was better to italicize our changes. The end result as I have stated is many now do not apply the definitions when developing designs. This is a problem that is not centralized to design professionals in my jurisdiction, we have seen it from design professionals all across the United States.

Horizontal branch drains are intended to serve as a collector for fixture discharge and convey the discharge to a stack or the building drain. The horizontal branch drain is intended to receive waste from the same floor level that requires little time to settle in a non-turbulent horizontal flow. The discharge of a stack into a horizontal branch drain results in the discharge affecting fixtures attached to the horizontal branch drain. The waste from a stack reaches terminal velocity resulting in "hydraulic jump" when the waste reached the base of the stack and transitions to a horizontal flow pattern.

In simple terms, if we look at different plumbing items as though they were part of the transportation infrastructure, we could identify **fixture drains** as neighborhood streets, **horizontal branch drains** as North/South, East /West connector streets (Main St., High St.), **stacks** and **building drains** as State Routes, and the **building sewers** and **public sewers** as the InterState Highways. Applying that logic, we can see we don't typically have the higher traffic roads discharging through the smaller roads. The plumbing code was designed the same way if people would apply the definitions.

Clearly this was something that was initially in people's minds when the code was developed and revised over the years as there are multiple instances where code language was written in such a way to prevent a stack from discharging to; a wet vent, a circuit vented horizontal branch drain, a combination waste and vent system. That language really just tiptoes around the issue though and has lead to a very blurred line.

Since as stated before, design professionals often are not applying the definitions, the same holds true for many plans examiners, inspectors and contractors. The intent of this proposal is to clearly define how the waste should be collected in each point of the process as it makes its way to the end point of disposal.

Cost Impact

The code change proposal will not increase or decrease the cost of construction .

This change is a simple clarification as to how a drainage system is built. This doesn't result in any change in code requirements and thus no impact to the costs of construction.

Internal ID: 2050

P112-18

IPC: 707.1

Proponent: James Richardson Jr, representing City of Columbus Ohio (jarichardson@columbus.gov); Robert Schutz, representing City of Columbus, OH (RJSchutz@columbus.gov)

2018 International Plumbing Code

Revise as follows:

707.1 Prohibited joints. The following types of joints and connections shall be prohibited:

1. Cement or concrete joints.
2. Mastic or hot-pour bituminous joints.
3. Joints made with fittings not *approved* for the specific installation.
4. Joints between different diameter pipes made with elastomeric rolling O-rings.
5. Solvent-cement joints between different types of plastic pipe except where provided for in Section 705.16.4.
6. Saddle-type fittings.
7. Double pattern fittings shall not be used in sanitary drains.

Reason:

We receive constant complaints about double pattern fittings from the service industry. Everyone who has ever ran a snake for any amount of time can attest to the issue with a double cross. We have all heard stories where a technician has pulled back a shower curtain from an adjacent restroom, even from an adjacent apartment. The service contractors are reporting issues where double pattern combination Wye & 1/8th bend and double pattern Wye's have been used in a horizontal configuration on a building drain. Videos have shown that waste is flowing straight across and blocking one of the branches causing backups to occur. Additionally, when they run snakes through the branches, as it reaches the double pattern fitting, often times the snake will go through to the other branch instead of turning in the intended direction of flow. This is a needless nuisance for a building owner and the occupants. These connections can be made simply by using a wye then upstream of the wye, a combination wye & 1/8th bend or just using another wye. The issue for the owners/occupants goes away and should result in a savings in maintenance costs for the owner.

Cost Impact

The code change proposal will increase the cost of construction .

There will be a small cost impact associated with this proposal as it will require an additional fitting and slightly more labor. These costs will be offset by the savings in maintenance costs.

Internal ID: 2019

P113-18 Part I

IPC: 708.1, 708.1.6 (New)

Proponent: Janine Snyder, City of Thornton, representing Colorado Association of Plumbing & Mechanical Officials (CAPMO) (Janine.Snyder@cityofthornton.net); Guy Tomberlin, Fairfax County, VA, representing Fairfax County Building Division (guy.tomberlin@fairfaxcounty.gov)

THIS IS A 2 PART CODE CHANGE PROPOSAL. PART I WILL BE HEARD BY THE IPC COMMITTEE. PART II WILL BE HEARD BY THE IRC-PLUMBING COMMITTEE. SEE THE TENTATIVE HEARING ORDERS FOR THESE COMMITTEES.

2018 International Plumbing Code

Add new text as follows:

708.1.6 Cleanout equivalent. A fixture trap or a fixture with integral trap, removable without altering concealed piping, shall be acceptable as a cleanout equivalent.

Revise as follows:

708.1 Cleanouts required. Cleanouts shall be provided for drainage piping in accordance with Sections 708.1.1 through ~~708.1.11~~708.1.12.

Analysis: The change in the section number in 708.1 is the result of adding new Section 708.1.6 which renumbers subsequent sections.

Internal ID: 2070

P113-18 Part II

IRC: P3005.2 P3005.2.10.1 (New)

Proponent: Janine Snyder, City of Thornton, representing Colorado Association of Plumbing & Mechanical Officials (CAPMO) (Janine.Snyder@cityofthornton.net); Guy Tomberlin, Fairfax County, VA, representing Fairfax County Building Division (guy.tomberlin@fairfaxcounty.gov)

2018 International Residential Code

Add new text as follows:

P3005.2.10.1 Cleanout Equivalent. A fixture trap or a fixture with integral trap, removable without altering the concealed piping shall be acceptable as a cleanout equivalent.

Revise as follows:

P3005.2 Cleanouts required. Cleanouts shall be provided for drainage piping in accordance with Sections P3005.2.1 through ~~P3005.2.11~~P3005.2.12.

Reason:

This is a companion change to the 2018 IRC subsection reintroduction of cleanout equivalents that was mistakenly left out during the reorganization of the cleanout section in the 2015 IRC. This is a viable option for cleanout equivalents in the IPC as well which is why the addition of the language is being proposed to match the IRC language.

Cost Impact

The code change proposal will decrease the cost of construction .

This will reduce the cost of construction by allowing fixtures such as water closets to be utilized as cleanouts, as have been allowed in the past.

Internal ID: 1362

P114-18

IPC: 708.1.8, Chapter 15

Proponent: Sidney Cavanaugh, representing LMK Technologies (sidneycavanaugh@yahoo.com)

2018 International Plumbing Code

Revise as follows:

708.1.8 Installation arrangement. The installation arrangement of a cleanout shall enable cleaning of drainage piping only in the direction of drainage flow.

Exceptions:

1. Test tees serving as cleanouts.
2. A two-way cleanout installation that is *approved* for meeting the requirements of Section 708.1.3.
3. A small bore vacuum excavation saddle installed in accordance with ASTM F3097.

Add new standard(s) follows:

ASTM

ASTM International
100 Barr Harbor Drive, P.O. Box
C700
West Conshohocken PA 19428-
2959
US

F3097-17:

Standard Practice for Installation of an Outside Sewer Service Cleanout through a Minimally Invasive Small Bore Vacuum Excavation

Reason:

This change is needed to recognize a less costly and invasive means of installing a clean out which may be used for maintenance and rehabilitation of building sewer and sewer service lateral.

Cost Impact

The code change proposal will not increase or decrease the cost of construction .

This type of cleanout is not required and therefore doesn't result in an increase in the cost of construction. Use of this type of cleanout could actually decrease the cost as the building sewer line does not have to be excavated to install a cleanout (tee).

Analysis: A review of the standard proposed for inclusion in the code, ASTM F3097-17, with regard to the ICC criteria for referenced standards (Section 3.6 of CP#28) will be posted on the ICC website on or before April 2, 2018.

Internal ID: 925

P115-18 Part I

IPC: 717 (New), Chapter 15

Proponent: Guy Tomberlin, Fairfax County, VA, representing The Virginia Plumbing and Mechanical Inspectors Assco. and the Virginia Building and Code Officials Assco Code Committee (guy.tomberlin@fairfaxcounty.gov); Janine Snyder, representing Colorado Association of Plumbing & Mechanical Officials (CAPMO) (Janine.Snyder@cityofthornton.net)

THIS IS A 2 PART CODE CHANGE PROPOSAL. PART I WILL BE HEARD BY THE IPC COMMITTEE. PART II WILL BE HEARD BY THE IRC-PLUMBING COMMITTEE. SEE THE TENTATIVE HEARING ORDERS FOR THESE COMMITTEES.

2018 International Plumbing Code

Add new text as follows:

717 RELINING BUILDING SEWERS AND BUILDING DRAINS

717.1 General. This section shall govern the relining of existing *building sewers and building drainage piping*.

717.2 Applicability. The relining of existing *building sewer* and building drainage piping shall be limited to gravity drainage piping, 4 inches (102 mm) in diameter and larger. The relined piping shall be of the same nominal size as the existing piping.

717.3 Pre-installation requirements. Prior to commencement of the relining installation, the existing piping sections to be relined shall be descaled and cleaned. After the cleaning process has occurred and water has been flushed through the system, the piping shall be inspected internally by a recorded video camera survey.

717.3.1 Pre-installation recorded video camera survey. The video survey shall include verification of the project address location. The video shall include notations of the cleanout and fitting locations, and the approximate depth of the existing piping. The video shall also include notations of the length of piping at intervals no greater than 25 feet.

717.4 Permitting. Prior to permit issuance, the code official shall review and evaluate the pre-installation recorded video camera survey to determine if the piping system is capable to be relined in accordance with the proposed lining system manufacturer's installation requirements and applicable referenced standards.

717.5 Prohibited applications.

Where review of the pre-installation recorded video camera survey reveals that piping systems are not installed correctly or defects exist, relining shall not be permitted. The defective portions of piping shall be exposed and repaired with pipe and fittings in accordance with this code. Defects shall include, but are not limited to, backgrade or insufficient slope, complete pipe wall deterioration or complete separations such as from tree root invasion or improper support.

717.6 Relining materials. The relining materials shall be manufactured in compliance with applicable standards and certified as required in Section 303. Fold -and-form pipe reline materials shall be manufactured in compliance with ASTM F1504 or ASTM F1871.

717.7 Installation. The installation of relining materials shall be performed in accordance with the manufacturer's installation instructions, applicable referenced standards and this code.

717.7.1 Material data report. The installer shall record the data as required by the relining material manufacture and applicable standards. The recorded data shall include but is not limited to the location of the project, relining material type, amount of product installed and conditions of the installation. A copy of the data report shall be provided to the code official prior to final approval.

717.8 Post-installation recorded video camera survey. The completed relined piping system shall be inspected internally by a recorded video camera survey after the system has been flushed and flow tested with water. The video survey shall be submitted to the the *code official* prior to finalization of the permit. The video survey shall be reviewed and evaluated to provide verification that no defects exist. Any defects identified shall be repaired and replaced in accordance with this code.

717.9 Certification. A certification shall be provided in writing to the code official, from the permit holder, that the

relining materials have been installed in accordance with the manufacturer's installation instructions, the applicable standards and this code.

717.10 Approval. Upon verification of compliance with the requirements of Sections 717.1 through 717.9, the code official shall approve the installation.

Add new standard(s) follows:

ASTM

ASTM International
100 Barr Harbor Drive, P.O. Box
C700
West Conshohocken PA 19428-
2959
US

F1504—2014:

Standard Specification for Folded Poly (Vinyl Chloride) (PVC) for Existing Sewer and Conduit Rehabilitation

F1871—2011:

Standard Specification for Folded/Formed Poly (Vinyl Chloride) Pipe Type A for Existing Sewer and Conduit Rehabilitation

Analysis: The referenced standards, ASTM F1504-2014 and F1871-2011, are currently referenced in the 2018 IRC.

Internal ID: 1881

P115-18 Part II

IRC: P3011, P3011.1, P3011.2, P3011.3, P3011.4, P3011.5, P3011.6, P3011.7, P3011.7.1 (New), P3011.7.2 (New), P3011.8 (New), P3011.9 (New), P3011.10 (New)

Proponent: Guy Tomberlin, Fairfax County, VA, representing The Virginia Plumbing and Mechanical Inspectors Assco. and the Virginia Building and Code Officials Assco Code Committee (guy.tomberlin@fairfaxcounty.gov); (janine.snyder@cityofthorton.net)

2018 International Residential Code

Revise as follows:

~~SECTION P3011 REPLACEMENT RELINING OF UNDERGROUND BUILDING SEWERS BY PVC FOLD AND FORM METHODS BUILDING DRAINS~~

~~P3011.1 General.~~ This section shall govern the ~~replacement relining of existing building sewer piping by PVC Fold and Form methods; and building drainage piping.~~

~~P3011.2 Applicability.~~ The ~~replacement relining of existing building sewer piping by PVC fold and form methods and building drainage piping~~ shall be limited to gravity drainage piping 4 inches (102 mm) ~~to 18 inches (457 mm).~~ The ~~replacement in diameter and larger.~~ The relined piping shall be of the same nominal size as the existing piping.

~~P3011.3 Preinstallation inspection Pre-installation Requirements.~~ ~~The Prior to commencement of the relining installation, the existing piping sections to be replaced relined shall be descaled and cleaned. After the cleaning process has occurred and water has been flushed through the system, the piping shall be inspected internally by a recorded video camera survey. The survey shall include notations of the position of cleanouts and the depth of connections to the existing piping.~~

Add new text as follows:

P3011.3.1 Pre-installation recorded video camera survey. The video survey shall include verification of the project address location. The video shall include notations of the cleanout and fitting locations, and the approximate depth of the existing piping. The video shall also include notations of the length of piping at intervals no greater than 25 feet.

P3011.4 Permitting. Prior to issuing a permit for relining, the building official shall review and evaluate the pre-installation recorded video camera survey to determine whether the piping system is capable to be relined in accordance with the proposed lining system manufacturer's installation requirements and applicable referenced standards.

Delete and substitute as follows:

~~3011.4 Pipe.~~ ~~The replacement piping shall be manufactured in compliance with ASTM F1504 or ASTM F1871.~~

~~3011.5 Prohibited applications.~~ ~~Where review of the pre-installation recorded video camera survey reveals that piping systems are not installed correctly, or defects exist, relining shall not be permitted. The defective portions of piping shall be exposed and repaired with pipe and fittings in accordance with this code. Defects shall include, but are not limited to, backslope or insufficient slope, complete pipe wall deterioration or complete separations such as from tree root invasion or improper support.~~

~~3011.5 Installation.~~ ~~The piping sections to be replaced shall be cleaned and flushed. Remediation shall be performed where there is groundwater infiltration, roots, collapsed pipe, dropped joints, offsets more than 12 percent of the inside pipe diameter or other obstructions.~~

~~3011.6 Relining materials.~~ ~~The relining materials shall be manufactured in compliance with applicable standards and certified as required in Section P2609. Fold-and-form pipe reline materials shall be manufactured in compliance with ASTM F1504 or ASTM F1871.~~

Add new text as follows:

P3011.7.1 Material data report. The installer shall record the data as required by the relining material manufacture and applicable standards. The recorded data shall include but is not limited to the location of the project, relining material type, amount of product installed and conditions of the installation. A copy of the data report shall be provided to the building official prior to final approval.

Delete and substitute as follows:

~~**3011.6 Cleanouts.** Where the existing *building sewer* did not have cleanouts meeting the requirements of this code, cleanout fittings shall be installed as required by this code.~~

~~**P3011.7 Installation.** The installation of relining materials shall be performed in accordance with the manufacturer's installation instructions, applicable referenced standards and this code.~~

~~**3011.7 Post-installation inspection.** The completed replacement piping shall be inspected internally by a recorded video camera survey. The video survey shall be reviewed and *approved* by the *building official* prior to pressure testing of the replacement piping system.~~

~~**P3011.8 Post-installation recorded video camera survey.** The completed relined piping system shall be inspected internally by a recorded video camera survey after the system has been flushed and flow tested with water. The video survey shall be submitted to the *code official* prior to finalization of the permit. The video survey shall be reviewed and evaluated to provide verification that no defects exist. Any defects identified shall be repaired and replaced in accordance with this code.~~

Delete without substitution:

~~**P3011.8 Pressure testing.** The replacement piping system as well as the connections to the replacement piping shall be tested in accordance with Section P2503.4.~~

Add new text as follows:

P3011.9 Certification. A certification shall be provided in writing to the building official, from the permit holder, that the relining materials have been installed in accordance with the manufacturer's installation instructions, the applicable standards and this code.

P3011.10 Approval. Upon verification of compliance with the requirements of Sections P3011.1 through P3011.9, the building official shall approve the installation.

Reason:

To date there has been limited to no code reference for all the technologies currently available to the reline piping systems. Many localities across the country are accepting it as an alternate material and method with no code guidance. This proposal is not an endorsement of any particular method or process. It does not promote or require relining. It simply provides installation and acceptance criteria when the application is encountered. This language will provide consistent application for all materials and technologies for the industry, including the code official and installers alike. Pipe relining technology has been successfully used for many years. It began with larger utility piping systems and has progressed into smaller piping systems that are privately owned and fall within the purview of the plumbing code. The process reduces the impact of open trench excavation's and thereby reduces repair cost according to industry data.

Cost Impact

The code change proposal will decrease the cost of construction .

Reducing open trench excavation, assisting with preservation of the natural environment and limiting destruction of private property will reduce the cost of plumbing repairs.

Internal ID: 1867

P116-18

IPC: 717 (New), 717.1 (New), Chapter 15

Proponent: Sidney Cavanaugh, representing LMK Technologies (sidneycavanaugh@yahoo.com)

2018 International Plumbing Code

Add new text as follows:

717 BUILDING SEWER AND SEWER SERVICE LATERAL REHABILITATION

717.1 Building sewer and sewer service lateral rehabilitation. Any rehabilitation of building sewer piping and sewer service lateral piping shall be in accordance with ASTM F2599. Any rehabilitation of building sewer and sewer service lateral pipe and its connection to the main sewer pipe shall be in accordance with F2561. All rehabilitation of building sewer piping and sewer service laterals shall include the use of hydrophilic rings or gaskets meeting ASTM F3240 to assure water tightness and elimination of ground water penetration.

Add new standard(s) follows:

ASTM

ASTM International
100 Barr Harbor Drive, P.O. Box
C700
West Conshohocken PA 19428-
2959

F2599-16:

Standard Practice for The Sectional Repair of Damaged Pipe By Means of An Inverted Cured-In-Place Liner

F2561-17:

Standard Practice for Rehabilitation of a Sewer Service Lateral and Its Connection to the Main Using a One Piece Main and Lateral Cured-in-Place Liner

F3240-17:

Standard Practice for Installation of Seamless Molded Hydrophilic Gaskets (SMHG) for Long-Term Watertightness of Cured-in-Place Rehabilitation of Main and Lateral Pipelines

Reason:

To add necessary requirements for rehabilitation of building sewers and sewer service laterals that are currently missing from IPC.

Cost Impact

The code change proposal will not increase or decrease the cost of construction .

In most cases this method would decrease cost of repair of existing piping because there would be no need to dig up and replacing existing piping.

Analysis: A review of the standard proposed for inclusion in the code, ASTM F2599-16, ASTM F2561-17, ASTM F3240- 17, with regard to the ICC criteria for referenced standards (Section 3.6 of CP#28) will be posted on the ICC website on or before April 2, 2018.

Internal ID: 507

P117-18

IPC: 903.1, 903.1.1 (New), 903.1.2 (New), 903.1.3 (New), 903.1.4 (New), 903.6

Proponent: Julius Ballanco, JB Engineering and Code Consulting, P.C., representing Tesla (JBEngineer@aol.com)

2018 International Plumbing Code

Revise as follows:

903.1 Roof extension-Vent terminal required. ~~Open vent pipes that extend through a roof shall be terminated not less than [NUMBER] inches (mm) above the roof. Where a roof is to be used for assembly or as a promenade, observation deck, sunbathing deck or similar purposes, open vent pipes shall terminate not less than 7 feet (2134 mm) above the roof. The vent pipe shall terminate by extending to the outdoors through the roof or the side wall in accordance with one of the methods identified in Section 903.1.1 through 903.1.4.~~

Add new text as follows:

903.1.1 Roof extension unprotected. Open vent pipes that extend through a roof shall be terminated not less than [NUMBER] inches (mm) above the roof.

903.1.2 Roof used for recreational or assembly purposes. Where a roof is to be used as a promenade, restaurant, bar, observation deck, sunbathing deck, or similar purposes, open vent pipes shall terminate not less than 7 feet (2134 mm) above the roof.

903.1.3 Protected vent terminal. Where an open vent pipe terminates above a sloped roof and is covered by either a roof-mounted panel (such as a solar collector or photovoltaic panel mounted over the vent opening) or a roof element (such as an architectural feature or a decorative shroud), the vent pipe shall terminate not less than 2 inches (51 mm) above the roof surface. Such roof elements shall be designed to prevent the adverse effects of snow accumulation and wind on the function of the vent. The placement of a panel over a vent pipe and the design of a roof element covering the vent pipe shall provide for an open area for the vent pipe to the outdoors that is not less than the area of the pipe, as calculated from the inside diameter of the pipe. Such vent terminals shall be protected by a method that prevents birds and rodents from entering or blocking the vent pipe opening.

903.1.4 Sidewall vent terminal. Vent terminals extending through the wall shall terminate not less than 10 feet (3048 mm) from the lot line and 10 feet (3048 mm) above the highest adjacent grade within 10 feet (3048 mm) horizontally of the vent terminal. Vent terminals shall not terminate under the overhang of a structure with soffit vents. Side wall vent terminals shall be protected to prevent birds or rodents from entering or blocking the vent opening.

Delete without substitution:

903.6 Extension through the wall. ~~Vent terminals extending through the wall shall terminate at a point not less than 10 feet (3048 mm) from a lot line and not less than 10 feet (3048 mm) above average ground level. Vent terminals shall not terminate under the overhang of a structure with soffit vents. Side wall vent terminals shall be protected to prevent birds or rodents from entering or blocking the vent opening.~~

Reason:

A similar change was proposed during the last cycle. There was concern regarding the wording used in the proposed code text. Those issues have been addressed with revised wording. A similar change was approved for inclusion in the International Residential Code-Plumbing Section.

The proposed change reorganizes vent terminal requirements. There are currently three options for a vent terminal, extending the vent (number) inches or more above the roof, extending the vent more than 7 feet above the roof when the roof is used for entertainment, or extending the vent through the side wall. However, the three requirements are separated between multiple sections. This makes the requirement readily identifiable in a section that presents all the options in one main section.

A fourth option for terminating the vent has been included. The fourth option would allow the vent to terminate 2 inches above a sloped roof when protected by a covering. This would allow photovoltaic solar collectors to be installed over vent terminals. It would also allow other protected vent terminals, such as architectural features that hide the vent for aesthetic purposes.

The size, length, and location of vent terminals has been a subject matter that has been greatly discussed over the last century. There are many myths, innuendoes, theories, and hypothesis regarding vent terminals. One of the most

complete papers on vent terminals was published by the National Bureau of Standards (NBS) in 1954, entitled, "Frost Closure of Roof Vents in Plumbing Systems," authored by Nerbert Eaton and Robert Wyly. Most of the current code requirements originate from the recommendations of this paper.

The NBS paper investigated plumbing roof vents and their termination throughout North America. Identified as a major concern is the frost closure of the vent terminal. Other concerns included snow blockage, shearing off of the vent terminal, and rainwater entrance.

Prior to this paper, it was largely alluded that the reason for a minimum size of 1-1/4 inch and a termination above the roof surface was to prevent a bird from building a nest and laying an egg to block off the vent. To this day, birds building nests in vents is a concern. However, that concern is more related to side wall venting that provides an easy opening for a bird to build a nest.

When a vent terminates lower to the roof, measures must be taken to prevent a bird from building a nest around the vent pipe and blocking it off. Increasing the size of the vent is one means used to avoid a bird's nest. Screening and vent covers also are used to prevent birds from building a nest.

The more pressing issue is how far above the roof a vent should terminate. Two issues of importance are water tightness of the flashing and preventing rainwater entrance into the plumbing vent. Modern day flashings can make the roof penetration water tight at much lower heights, including a termination 2 inches above the roof.

The NBS report suggested a minimum of 2 inch penetration above the roof to prevent rainwater from entering the plumbing vent. It is recognized that a flat roof can have a greater accumulation of water hence the need for the vent to be at a higher elevation. Typically secondary roof drains are located between 2 and 4 inches above the roof. Thus, the vent terminal would have to be located at a higher height which is the reason for maintaining a minimum of inserting the appropriate number of inches above the roof for a flat roof.

The NBS report identified a vent terminal used in Saskatoon, Canada that terminates at the sloped roof. There was no extension above the roof. This was found to be extremely effective in preventing frost closure. As the NBS report states, the closer the vent terminates to the roof, the lower the possibility of frost closure. The report also found that by making the vent a minimum of 3 inch in diameter, frost closure that impacts the performance of the venting system was avoided.

Snow accumulation has been a subject of more recent discussions regarding vent terminals. However, snow accumulation was addressed in the NBS report. The NBS report found that while snow may completely cover the vent terminal, the snow eventually melts from the heated vapors emanating out of the vent. Prior to the snow melting, the NBS report found that the snow cover did not impact the performance of the vent. This makes sense since the purpose of the vent is to balance the pressure in the drainage system with atmospheric pressure. The snow cover is not dense enough to prevent the balancing of pressure in the piping system.

The current code requires the vent to terminate at a height specified by the jurisdiction. The Residential Code requires the termination to be 6 inches above the anticipated snow cover. The requirement add the local value remains intact. However, when the vent is covered, such as by a solar panel or architectural feature, it cannot be covered by snow such that the vent doesn't perform properly. Thus, the vent could terminate at a 2 inch height above a sloped roof.

In the mountain west, shearing of the roof vent is a problem when the snow and ice melt and slide off of sloped roofs. By extending the vent higher through the roof, there is a greater force applied on the vent that can result in the pipe being sheared off. If the vent is lowered, the force on the vent during snow and ice slides is also lowered. This may reduce the shearing incidents of vent pipes. However, that is not part of the reason for lowering the vent terminal height. The vent would be protected if installed at a lower height. Hence, the snow and ice slides would have little to no impact on the vent since it is covered.

Plumbing contractors in the mountain west with heavy snow and ice accumulations have found that the more practical solution is to extend the vent through the roof closer to the peak of the roof. Thus, the force from sliding snow and ice is lowered. This has not been addressed in this code change and is more of a regional issue addressed by knowledgeable local contractors.

The remaining issue that is not often addressed for vent terminals is the impact of wind. During windy conditions, the vent terminal can create a reduced pressure zone that siphons the trap seal. This is often called a Venturi effect. The other concern is downdrafts that can increase the pressure in the drainage system. However, downdrafts have not had a major impact on the drainage system based on the termination height above the roof. While the possibility exists that a lower vent termination height could result in higher wind downdrafts, this has not proven to be the case. However, the code requirement addresses downdrafts by requiring the covering to prevent any adverse impact from wind.

What the plumbing profession must acknowledge is that solar is a viable source of energy for a building. As such, accommodations must be made to allow for the maximum area of roof coverage with solar panels. This may require the adjustment in the height of the vent terminal.

While accommodations must be made, there cannot be a sacrifice of public health. The lowering of the vent terminal to 2 inches on a sloped roof will not impact public health. This was proven by the NBS study published in 1954. Furthermore, modern building practices will result in a water tight vent terminal that will perform as intended.

Bibliography:

“Frost Closure of roof Vents in Plumbing Systems,” Herbert N. Eaton and Robert S. Wyly, BMS Report 142, published 1954, United States Department of Commerce, National Bureau of Standards.

National Plumbing Code Handbook, Standards and Design Information, Vincent T. Manas, P.E., copyright 1957, McGraw-Hill Book Company

Cost Impact

The code change proposal will decrease the cost of construction .

Options for vent termination will be provided. This will lower the cost of construction.

Internal ID: 1311

P118-18

IPC: 915.1

Proponent: Julius Ballanco, JB Engineering and Code Consulting, P.C., representing InSinkErator (JBENGINEER@aol.com)

2018 International Plumbing Code

Revise as follows:

915.1 Type of fixtures. A *combination waste and vent system* shall not serve fixtures other than floor drains, sinks, lavatories and drinking fountains. *Combination waste and vent systems* shall not receive the discharge from a ~~food waste disposer or~~ clinical sink.

Reason:

The ASPE Research Foundation did a study on food waste disposers discharging through a combination waste and vent system. There was no problem found with the installation of a combination waste and vent system connecting a food waste disposer. Testing was performed with both residential and commercial food waste disposers. A copy of the ASPE Research Foundation report is included with this submittal. This paper documents why this current code restriction is unnecessary.

A series of videos taken during the research project can be viewed at: <https://aspe.org/FoodDisposerTestVideos>.

A similar restriction in the Residential Code Plumbing Section was removed during the last code change cycle. This IPC should be consistent with the IRC plumbing requirements.

Cost Impact

The code change proposal will decrease the cost of construction .

This will allow a lower cost venting system where a food waste disposer is installed.

Internal ID: 884

P119-18

IPC: 202, 919 (New), 919.1 (New), 919.2 (New), Chapter 15

Proponent: Ronald George, representing IPS corporation (Ron@Plumb-TechLLC.com)

2018 International Plumbing Code

Add new definition as follows:

POSTIVE PRESSURE REDUCTION DEVICE A device that is connected to a drainage or vent stack to attenuate pressure waves and reduce pressure fluctuations in the sanitary waste & vent system to within acceptable levels.

Add new text as follows:

919 POSITIVE PRESSURE REDUCTION DEVICES

919.1 General. Positive pressure reduction devices used in vent systems shall comply with ASSE 1030.

919.2 Installation. The installation of positive pressure reduction devices in sanitary drainage and vent systems shall be in accordance with the device manufacturer's instructions.

Add new standard(s) follows:

ASSE

ASSE International
18927 Hickory Creek Drive, Suite
220
Mokena IL 60448

1030-2016:

Performance Requirements for Positive Pressure Reduction Devices for Sanitary Drainage Systems

Reason:

This proposal adds a definition for positive pressure reduction devices and a standard for such devices. Positive pressure reduction devices (hereafter referred to as "device") are to be used in building drainage waste and vent (DWV) systems. They are intended to reduce the impact of short duration air pressure transients that arise in DWV stacks through use. The device consists of a variable volume reservoir contained within a ventilated rigid outer casing with an inlet connection by which the reservoir inflates when subjected to positive pressure. In its inactive state, the flexible reservoir is deflated. Expansion only occurs in response to an increase in line pressure at the entrance to the device. This expansion provides a variable volume reservoir for air. The device connects to the drainage network via an airtight seal to prevent the diversion of airflow from entering the reservoir. As a result, the reservoir becomes an integral part of the drainage network.

P.A.P.A.™ - Positive Air Pressure Attenuator



The P.A.P.A. device is the perfect complement to Studor Air Admittance Valves. Together they form an Engineered System known as "Studor Single Pipe System (SSPS)", a total solution to building venting requirements. The Studor AAVs deal with negative pressure in the system while the P.A.P.A. effectively deals with the positive pressure transients. The combination of the two maintains the perfect system balance quickly and efficiently throughout the system preventing siphonage and blowing of traps.

- For Commercial use
- The P.A.P.A. can be used in conjunction with a conventional DWV system
- ASSE 1030 - Positive Pressure Reduction Devices for Sanitary Drainage Systems

DIMENSIONS

A		B		Nominal Pipe Size	
C		D		E	
7-7/16"		29-1/2"		3" Spigot	



CAPACITY

Series Assembly	
Maximum Number of Units: 4	
Air Capacity	US Gallons
1 Unit	1
2 Units	2
3 Units	3
4 Units	4

The P.A.P.A. is rated for 5 PSI

Weight: 5 pounds

Bibliography:

Pages 29 through 44 & 49 of Studor Technical Manual, 9th Edition

Web Link: http://ipscorp.com/pdf/studor/Studor_Technical_Manual.pdf

Cost Impact

The code change proposal will not increase or decrease the cost of construction .

This is only an option that is not required to be used. When used in single stack drainage systems, it can decrease the cost of construction, however these devices can be used in any sanitary waste and vent system that is experiencing pressure fluctuations and it will attenuate pressure waves.

Analysis: A review of the standard proposed for inclusion in the code, ASSE 1030-2016, with regard to the ICC criteria for referenced standards (Section 3.6 of CP#28) will be posted on the ICC website on or before April 2, 2018.

P120-18

IPC: 1002.1

Proponent: James Richardson Jr, representing City of Columbus Ohio (jarichardson@columbus.gov); Robert Schutz, representing City of Columbus, OH (RJSchutz@columbus.gov)

2018 International Plumbing Code

Revise as follows:

1002.1 Fixture traps. Each plumbing fixture shall be separately trapped by a liquid-seal trap, except as otherwise permitted by this code. The vertical distance from the fixture outlet to the trap weir shall not exceed 24 inches (610 mm), and the horizontal distance shall not exceed 30 inches (610 mm) measured from the centerline of the fixture outlet to the centerline of the inlet of the trap. The height of a clothes washer standpipe above a trap shall conform to Section 802.3.3. A fixture shall not be double trapped.

Exceptions:

1. This section shall not apply to fixtures with integral traps.
2. A combination plumbing fixture is permitted to be installed on one trap, provided that one compartment is not more than 6 inches (152 mm) deeper than the other compartment and the waste outlets are not more than 30 inches (762 mm) apart.
- ~~3. A grease interceptor intended to serve as a fixture trap in accordance with the manufacturer's installation instructions shall be permitted to serve as the trap for a single fixture or a combination sink of not more than three compartments where the vertical distance from the fixture outlet to the inlet of the interceptor does not exceed 30 inches (762 mm) and the *developed length* of the waste pipe from the most upstream fixture outlet to the inlet of the interceptor does not exceed 60 inches (1524 mm).~~
- ~~4.3.~~ Floor drains in multilevel parking structures that discharge to a building storm sewer shall not be required to be individually trapped. Where floor drains in multilevel parking structures are required to discharge to a combined *building sewer* system, the floor drains shall not be required to be individually trapped provided that they are connected to a main trap in accordance with Section 1103.1.

Reason:

This is an error in the code that has been present since the change was made to section 802.1.7 requiring that utensil/pot/pan sinks to be indirectly connected. Previously a direct connection was also permissible, which promulgated exception # 3. Since a direct connection is no longer permissible for these type of sinks, exception # 3 would be in direct violation of 802.1.7

Bibliography:

2018 International Plumbing Code

PUB. - 08/31/2017

802.1.7 Food utensils, dishes, pots and pans sinks.

Sinks, in other than dwelling units, used for the washing, rinsing or sanitizing of utensils, dishes, pots, pans or service ware used in the preparation, serving or eating of food **shall discharge indirectly through an air gap or an air break to the drainage system.**

1002.1 Fixture traps.

Each plumbing fixture shall be separately trapped by a liquid-seal trap, except as otherwise permitted by this code. The vertical distance from the fixture outlet to the trap weir shall not exceed 24 inches (610 mm), and the horizontal distance shall not exceed 30 inches (610 mm) measured from the centerline of the fixture outlet to the centerline of the inlet of the trap. The height of a clothes washer standpipe above a trap shall conform to Section 802.3.3. A fixture shall not be double trapped.

Exceptions:

1. This section shall not apply to fixtures with integral traps.
2. A combination plumbing fixture is permitted to be installed on one trap, provided that one compartment is not more than 6 inches (152 mm) deeper than the other compartment and the waste outlets are not more than 30 inches (762 mm) apart.

3. A grease interceptor intended to serve as a fixture trap in accordance with the manufacturer's installation instructions shall be permitted to serve as the trap for a single fixture or a combination sink of not more than three compartments where the vertical distance from the fixture outlet to the inlet of the interceptor does not exceed 30 inches (762 mm) and the developed length of the waste pipe from the most upstream fixture outlet to the inlet of the interceptor does not exceed 60 inches (1524 mm).

4. Floor drains in multilevel parking structures that discharge to a building storm sewer shall not be required to be individually trapped. Where floor drains in multilevel parking structures are required to discharge to a combined building sewer system, the floor drains shall not be required to be individually trapped provided that they are connected to a main trap in accordance with Section 1103.1.

Cost Impact

The code change proposal will not increase or decrease the cost of construction .

There will be no cost impact due to the fact that the requirement is already in chapter 8 for an indirect connection.

Internal ID: 1533

P121-18

IPC: 1002.4.1.1

Proponent: Ed Osann, representing Natural Resources Defense Council (eosann@nrdc.org)

2018 International Plumbing Code

Revise as follows:

1002.4.1.1 Potable water-supplied trap seal primer valve. A potable water-supplied trap seal primer valve shall supply water to the trap. Water-supplied trap seal primer valves shall conform to ASSE 1018-, and shall be of the type that uses not more than 30 gallons per year per trap. The discharge pipe from the trap seal primer valve shall connect to the trap above the trap seal on the inlet side of the trap.

Reason:

A water-supplied trap seal primer that is unrestricted can discharge 300 to 500 gallons a year to a trap. By comparison, a 2-inch trap, for example, actually requires less than 1/2 gallon per year to maintain the trap seal. Trap seal primer valves that limit the amount of water discharged to 8 gallons per year have been on the market for several years.

The maximum of 30 gallons of discharge per year in this proposal is contained in both the 2015 International Green Construction Code (IgCC) and the 2015 IAPMO Green Plumbing and Mechanical Code Supplement. It is time to bring this common-sense requirement into the IPC to prevent an unnecessary waste of drinking water.

Bibliography:

2015 International Green Construction Code, International Code Council, 2015, sec. 702.8.2.

2015 Green Plumbing and Mechanical Code Supplement, International Association of Plumbing and Mechanical Officials, 2015, sec. 415.1.

Cost Impact

The code change proposal will not increase or decrease the cost of construction .

This code change proposal applies to only one of four available compliance paths where trap seal protection is required, and thus will not increase the cost of construction.

Internal ID: 1621

P122-18

IPC: 1002.4.1.5 (New), 1002.4.1

Proponent: James Richardson Jr, representing City of Columbus Ohio (jarichardson@columbus.gov); Robert Schutz, representing City of Columbus, OH (RJSchutz@columbus.gov)

2018 International Plumbing Code

Add new text as follows:

1002.4.1.5 Fixture drain connection for trap priming. A fixture drain from a lavatory or hand sink shall serve as a method of providing trap seal protection for an emergency floor drain, a trench drain, or a floor sink where such fixtures are located in the same room. A fixture drain from a drinking fountain shall serve as a method of providing trap seal protection for an emergency floor drain, a trench drain, or a floor sink where such fixtures are in the same room or in a room adjacent to the room having the drinking fountain. The fixture drain shall not be routed on or above the surface of the floor and shall connect to the floor drain, trench drain, or floor sink at a point that is below the flood level rim and above the inlet to the trap of the receiving fixture.

Revise as follows:

1002.4.1 Trap seal protection. Trap seals of *emergency floor drain* traps and trap seals subject to evaporation shall be protected by one of the methods in Sections 1002.4.1.1 through ~~1002.4.1.4~~1002.4.1.5.

Reason:

This is a method of providing trap seal protection that can lower the owner's overall cost of maintenance and requires no special or certified product to do so.

Currently the 2018 International Plumbing Code allows for reclaimed or gray water supplied trap primer devices that comply with ASSE 1018, as well as a waste water supplied device that complies with ASSE 1044. The proposed method simply removes the need for any "certified" product. Experience has proven that the ASSE 1018 devices don't typically have a record of providing long service, maintenance issues have also been reported with the 1044 devices. When owners decide to go back to using gel type soaps even though the manufacture specifically states the need for foaming soap, the 1044 device have a tendency to plug up with the gel soaps over time which requires maintenance intervention. The maintenance for the 1018 device is even more problematic, often we would be replacing these devices within 6-12 months of installation. This proposed method is essentially already something that is allowed by the code. We have used this method since before I entered into the plumbing trade and have never had a complaint about it failing or creating an unsafe/serious condition for an occupancy.

2018 International Plumbing Code

PUB. - 08/31/2018

1002.4.1.2 Reclaimed or gray water-supplied trap seal primer valve.

A reclaimed or gray water-supplied trap seal primer valve shall supply water to the trap. Water-supplied trap seal primer valves shall conform to ASSE 1018. The quality of reclaimed or gray water supplied to trap seal primer valves shall be in accordance with the requirements of the manufacturer of the trap seal primer valve. The discharge pipe from the trap seal primer valve shall connect to the trap above the trap seal, on the inlet side of the trap.

1002.4.1.3 Waste water-supplied trap primer device.

A waste water-supplied trap primer device shall supply water to the trap. Waste water-supplied trap primer devices shall conform to ASSE 1044. The discharge pipe from the trap seal primer device shall connect to the trap above the trap seal on the inlet side of the trap

Cost Impact

The code change proposal will decrease the cost of construction .

This method should actually result in a decrease cost of construction because no special trap priming devices are required. The fixture drain already has to be piped, it is just piped to the fixture needing trap priming. This will also save maintenance costs because trap priming devices will not need repaired/replaced.

Internal ID: 1534

P123-18

IPC: 1003.3.2

Proponent: Julius Ballanco, JB Engineering and Code Consulting, P.C., representing InSinkErator (JBENGINEER@aol.com)

2018 International Plumbing Code

Revise as follows:

1003.3.2 Food waste disposers restriction. A food waste disposer shall not discharge to a grease interceptor.

Exception: A two or three compartment sink that is required to discharge to a grease interceptor shall be permitted to have a food waste disposer provided that the disposer rating is not greater than 1.0 horsepower.

Reason:

The commercial food handling industry has requested that small food waste disposers be permitted on two or three compartment sinks to handle the incidental food waste that accumulates in the wash sink after cleaning. The food waste disposer would not be the typical commercial food waste disposer unit handling all of the food waste from the establishment. It would only account for a small portion of food waste remaining during the washing operation.

Cost Impact

The code change proposal will not increase or decrease the cost of construction .

The allowance for having a small disposer discharging to a grease interceptor could save the cost of materials and labor of needing a separate sink just for a small disposer and the need for separate drainage piping to connect that sink downstream of the interceptor.

Internal ID: 1882

P124-18

IPC: 1003.3.2.1 (New)

Proponent: Julius Ballanco, JB Engineering and Code Consulting, P.C., representing InSinkErator (JBENGINEER@aol.com)

2018 International Plumbing Code

Add new text as follows:

1003.3.2.1 Existing installations. For existing installations where the food waste disposer discharges through the grease interceptor, the grease interceptor shall be properly sized to include the discharge from the food waste disposer. The sizing of the grease interceptor shall be based on the continuous flow from the food waste disposer.

Reason:

The code was revised to add the prohibition for the discharge of food waste disposers through grease interceptors. However, there are many existing installations where the food waste disposer discharges through the grease interceptor. When the grease interceptor is replaced, the sizing must include the increase load from the food waste disposer.

It is common practice to have the food waste disposer operating in a food handling establishment. When connected to a grease interceptor, this can add a greater load than normal dishwashing sinks. This additional load must be considered when sizing the replacement grease interceptor. The time interval between cleaning of the grease interceptor must also be considered.

In a recently published paper, "A critical review of fat, oil, and grease (FOG) in sewer collection systems: Challenges and control," the importance of properly sizing and maintaining a grease interceptor was identified as a means of reducing the problems of FOG build up in public sewer systems. This proposed change will provide guidance in the proper sizing when an existing system has a food waste disposer discharging to a grease interceptor. This will reduce the contributions of FOG to the public sewer system.

Cost Impact

The code change proposal will not increase or decrease the cost of construction .

This addresses existing installations and has no impact on the cost.

Internal ID: 885

P125-18

IPC: 1106.2, 1106.2.1 (New), TABLE 1106.2.1 (New), 1106.2.1.1 (New), 1106.2.1.2 (New), 1106.2.2 (New), 1106.2.2.1 (New)

Proponent: Julius Ballanco, JB Engineering and Code Consulting, P.C., representing Self (JBEngineer@aol.com)

2018 International Plumbing Code

Revise as follows:

~~**1106.2 Size of storm drain piping.** Storm drain pipe sizing. Vertical and horizontal. The storm drain drainage piping shall be sized based on the flow rate through the roof drain. The flow rate in storm drain piping shall not exceed that specified in Table 1106.2 in accordance with Section 1106.2.1 or Section 1106.2.2.~~

Add new text as follows:

1106.2.1 Roof drainage. The rainwater drainage flow rate from the roof surface shall be determined based on the rainfall rate of a 60 minute storm with a 100 year return period and the area of the roof being drained in accordance with Table 1106.2.1.

**TABLE 1106.2.1
ROOF AREA DRAINAGE FLOW RATE**

Roof Drainage Area (sq. ft.)	Drainage Flow Rate (gpm)					
	Based on Rainfall Rates (in/hr)					
	1	2	3	4	5	6
500	5	10	16	21	26	31
1000	10	21	31	42	52	62
1500	16	31	47	62	78	94
2000	21	42	62	83	104	125
2500	26	52	78	104	130	156
3000	31	62	94	125	156	187
3500	36	73	109	145	182	218
4000	42	83	125	166	208	249
4500	47	94	140	187	234	281
5000	52	104	156	208	260	312
5500	57	114	171	229	286	343
6000	62	125	187	249	312	374
6500	68	135	203	270	338	405
7000	73	145	218	291	364	436
7500	78	156	234	312	390	468
8000	83	166	249	332	416	499
9000	94	187	281	374	468	561
10000	104	208	312	416	519	623
11000	114	229	343	457	571	686
12000	125	249	374	499	623	748

1106.2.1.1 Roof drain. The flow rate used for sizing the roof drainage system shall be not less than the roof drain manufacturer's published flow rate based on a head height of 4 inches (102 mm) of water ponding. Storm drainage piping shall be sized in accordance with Table 1106.2.

1106.2.1.2 Secondary roof drainage. The opening for the secondary roof drainage shall be not less than 2 inches (51 mm) and not more than 5 inches (76 mm) above the bottom opening of the primary roof drain.

1106.2.2 Engineered Roof Drain Flow Rate. Vertical and horizontal storm drain piping shall be sized based on the flow rate through the roof drain. The flow rate used for sizing the storm drainage piping shall be based on the maximum anticipated ponding at the roof drain based on a rainfall rate of a 60 minute storm with a 100 year return period and a 5 minute storm with a 10 year return period. The flow rate used for sizing the storm drainage piping system shall be the manufacturer's published flow rate for the roof drain based on the established maximum anticipated water ponding height. The storm drainage piping shall be sized in accordance with Table 1106.2.

1106.2.2.1 Secondary roof drainage. The discharge through the secondary roof drain shall not be considered when establishing the maximum height of ponding at the primary roof drain. The opening for the secondary roof drainage shall be not less than 2 inches (51 mm) above the bottom opening of the primary roof drain.

Reason:

The code was revised a few cycles ago to reflect the research published by the ASPE Research Foundation. ASPE RF and IAPMO cosponsored research on the performance of roof drains in storm drainage systems. There has been a number of requests for a fast sizing method that does not require engineering calculations. The change adds such a fast, cook-book method of sizing the storm drainage piping system.

The ASPE RF research report states the problem associated with a storm drainage system is the improper sizing of the storm drainage pipe. The old sizing method did not account for the high quality of the roof drain. The research report is included with the submittal and can be downloaded at no cost at www.aspe.org.

The code change identifies two methods for sizing the storm drainage system. The first sizing method listed in Section 1106.2.1 Roof Drainage, is the quick sizing method. When using this method, the storm drain pipe may be sized large

than the engineered sizing method. The quick method will not result in smaller diameter pipe for the storm drainage system.

These requirements respond to the request by inspectors, contractors, and engineers. The first sizing method identified was developed to provide a cookbook method of sizing rather than conducting a full engineering design analysis. The sizing of the storm drainage system still relies on the values published by the roof drain manufacturers. This data identifies the flow rate based on head height through the roof drain.

Because the method takes a cookbook approach, the secondary roof drainage must be considered. For that reason, secondary roof drainage is required to be between 2 inch and 5 inches above the primary roof drainage. This is calculated into the flow rate sizing values in Table 1106.2.1. It will assure that the system will not exceed the ponding height determined in flow calculations.

The second method, identified as Section 1106.2.2 Engineered Roof Drain Flow Rate, is the current sizing method required by the code. One change has been added to the engineered sizing method. The engineered sizing will require the evaluation of the roof drainage system for a microburst, which is a 5-minute storm with a 10-year return period. While a 100-year storm may appear to be the most drastic storm for sizing a system, a microburst can overpower the storm drainage piping resulting in failure of the piping system. The microburst will typically not have a significant impact on the roof loading compared to a 100-year storm of 60-minute duration. The ASPE RF research report recommends the evaluation of both a 100-year storm of 60 minutes duration and a 10-year storm of 5-minute duration.

Cost Impact

The code change proposal will not increase or decrease the cost of construction .

This provides an option for sizing the storm drainage system and options usually lower the cost of construction.

Internal ID: 1313

P126-18

IPC: 1102.6, Chapter 15

Proponent: Julius Ballanco, JB Engineering and Code Consulting, P.C., representing Froet Industries (JBEngineer@aol.com)

2018 International Plumbing Code

Revise as follows:

1102.6 Roof Drains. Roof drains shall conform to ASME A112.6.4 or ASME A112.3.1. Roof drains, other than siphonic roof drains, shall be tested and rated in accordance with ASME A112.6.4 or ASPE/IAPMO Z1034.

Add new standard(s) follows:

ASPE

American Society of Plumbing
Engineers
6400 Shafer Ct., Suite 350
Rosemont IL 60018-4914

ASME/IAPMO 21034-2015:

Test Method for Evaluating Roof Drain Performance

Reason:

ASPE/IAPMO Z1034 is the consensus standard for testing and rating roof drains for their flow rate at different ponding heights. The current code requires the manufacturer to publish their flow rates. The flow rates are determined by testing to either of the two standards referenced.

Siphonic roof drains are rated differential with the system designed in accordance with ASPE 45 and the roof drain tested in accordance with ASME A112.6.9.

The testing requirements in the standard are consistent with the results published in the ASPE Research Foundation Roof Drainage Research Report. There are third party laboratories currently testing and certifying roof drains to the ASPE/IAPMO Z1034 standard.

Cost Impact

The code change proposal will increase the cost of construction .

There is a cost associated with the testing of roof drains.

Analysis: A review of the standard proposed for inclusion in the code, ASPE/IAPMO 21034-2015, with regard to the ICC criteria for referenced standards (Section 3.6 of CP#28) will be posted on the ICC website on or before April 2, 2018.

Internal ID: 1173

P127-18

IPC: 1105.1

Proponent: Mark Jelinske, representing Self (mjelinske@rmhgroup.com)

2018 International Plumbing Code

Delete without substitution:

~~**1105.2 Roof drain flow rate.** The published roof drain flow rate, based on the head of water above the roof drain, shall be used to size the storm drainage system in accordance with Section 1106. The flow rate used for sizing the storm drainage piping shall be based on the maximum anticipated ponding at the roof drain.~~

Reason:

Recent (Dec 2017) conversations and correspondence with major roof drain manufacturers have indicated that there is no published flow data for roof drains, no recognized standards for testing the flow rate of roof drains, and no industry initiative to develop such testing programs.

While a good idea, this provision is premature until there are recognized standards developed, and until the manufacturers have developed the performance data from these standards.

Cost Impact

The code change proposal will not increase or decrease the cost of construction .

This has no cost impact since there is no practical method to comply with the provisions of this section anyway. If anything, this proposal will reduce cost for the unlucky project forced to comply, since at present, a construction project would have to fund the development of a testing standard, fund a laboratory to perform such testing, and fund the publication of the data.

Internal ID: 1143

P128-18

IPC: 1105.2

Proponent: James Richardson Jr, representing City of Columbus Ohio (jarichardson@columbus.gov); Robert Schutz, representing City of Columbus, OH (RJSchutz@columbus.gov)

2018 International Plumbing Code

Revise as follows:

1105.2 Roof drain flow rate. The published roof drain flow rate, based on the head of water above the roof drain, shall be used to size the storm drainage system in accordance with Section 1106. The flow rate used for sizing the storm drainage piping shall be based on the ~~maximum anticipated ponding height water~~ at the roof drain should not exceed with regard to the weight of ponding water equal to the acceptable threshold established by the structural engineer.

Reason:

The previous revision to this code section left no real direction or parameters for design professionals. This proposal is simply suggesting at the minimum height of water that should be used when calculating the flow rate through the roof drain should be equal to the height ponding water would reach yet stay below the maximum weight threshold as established by the structural engineer.

Cost Impact

The code change proposal will not increase or decrease the cost of construction .

This is only providing providing direction for minimum safety.

Internal ID: 2358

P129-18

IPC: 1106.2, 1106.2.1 (New)

Proponent: Ronald George, Plumb-Tech Design & Consulting Services LLC, representing Self (Ron@Plumb-TechLLC.com)

2018 International Plumbing Code

Revise as follows:

1106.2 Size of storm drain piping. Vertical and horizontal storm drain piping shall be sized based on the flow rate through the roof drain. The flow rate, as calculated in accordance with Section 1106.2.1, shall be checked against the roof drain manufacturer's published flow rate for the specific roof drain model and size to verify that the selected roof drain will handle the anticipated flow. The flow rate in storm drain piping shall not exceed that specified in Table 1106.2.

Add new text as follows:

1106.2.1 Rainfall rate conversion method. The rainfall rate falling on a roof surface shall be converted to a gallons per minute flow rate in accordance with Equation 11-1.

GPM = R • A • 0.0104 (Equation 11-1)

where,

R = Rainfall intensity in inches per hour

A = Roof area in square feet

Reason:

The flow rates for various pipe sizes in the roof drain sizing table were changed from square feet (SF) to gallons per minute (GPM). This code change simply adds a calculation from SF to GPM.

Cost Impact

The code change proposal will not increase or decrease the cost of construction .

This code change only adds a calculation method and a caution about selecting an appropriate roof drain model.

Internal ID: 2246

P130-18

IPC: TABLE 1106.2

Proponent: Mark Jelinske, representing Self (mjelinske@rmhgroup.com)

2018 International Plumbing Code

Revise as follows:

**TABLE 1106.2
STORM DRAIN PIPE SIZING**

PIPE SIZE (inches)	CAPACITY ^a (gpm)				
	VERTICAL DRAIN	SLOPE OF HORIZONTAL DRAIN			
		$\frac{1}{16}$ inch per foot	$\frac{1}{8}$ inch per foot	$\frac{1}{4}$ inch per foot	$\frac{1}{2}$ inch per foot
2	34	15	22	31	44
3	87	39	55	79	111
4	180	81	115	163	231
5	311	117	165	234	331
6	538	243	344	487	689
8	1,117	505	714	1,010	1,429
10	2,050	927	1,311	1,855	2,623
12	3,272	1,480	2,093	2,960	4,187
15	5,543	2,508	3,546	5,016	7,093

For SI: 1 inch = 25.4 mm, 1 foot = 304.8 mm, 1 gallon per minute = 3.785 L/m.

a. Values based on PVC piping. For cast iron pipe other than 5 inches, multiply the indicated capacity by 0.75.

Reason:

When this table was added to the 2015 IPC, it was based on PVC pipe, except for 5" which was based on cast iron. See the ICC 2012/2013 Code Development Cycle Group A Proposal P219-12. This is the smoothest pipe allowed by the IPC. Cast Iron is still a commonly used material, but is a rougher pipe, and therefore has a different flow capacity.

Gravity flow through a pipe is governed by the Gauckler–Manning formula. A roughness coefficient is used to account for the different roughness of materials. Flow is directly proportional to this roughness factor.

The roughness factor is generally given as 0.009 for PVC , and as 0.012 for cast iron. Since flow is directly proportional to roughness for the same diameter and slope, cast iron pipe is $0.009/0.012 = 0.75$ the capacity of PVC.

Using the smoothest possible pipe as the basis of the code will result in undersized pipe if not corrected for rougher pipe.

Since codes usually assume a worst case in establishing minimum requirements, an alternate method would be to modify the table with cast iron as the basis and allowing a $0.012/0.009 = 1.33$ credit if PVC is used.

It is recognized that there are other materials allowed, but PVC and cast iron are overwhelmingly dominant. Cast iron is the roughest, and PVC is the smoothest. In the interest of keeping this table simple, this proposal is just establishing the range of options, a designer can document alternate factors for other materials if desired.

Bibliography:

INTERNATIONAL CODE COUNCIL 2012/2013 CODE DEVELOPMENT CYCLE Group A (2012) PROPOSED CHANGES TO THE 2012 EDITIONS OF THE INTERNATIONAL PLUMBING CODE

P219 - 12

Pages 283-285

https://cdn-web.iccsafe.org/wp-content/uploads/05_IPC1.pdf

Cost Impact

The code change proposal will increase the cost of construction .

This proposal will not increase the cost of correctly sized cast iron storm drainage systems. This will avoid the potential costs involved with an undersized cast iron system if a designer does is not aware of the limitations of the table. The above statement is based on the assumption that many designers are not aware that the table will undersize a cast iron system.

Internal ID: 1978

P131-18 Part I

IPC: 1301.1.1 (New), Chapter 15

Proponent: Dave Cantrell, representing The Joint CSA/ICC Rainwater System Design and Installation Consensus Committee (dave.cantrell.codes@gmail.com)

THIS IS A 2 PART CODE CHANGE PROPOSAL. PART I WILL BE HEARD BY THE IPC COMMITTEE. PART II WILL BE HEARD BY THE IRC-PLUMBING COMMITTEE. SEE THE TENTATIVE HEARING ORDERS FOR THESE COMMITTEES.

2018 International Plumbing Code

Add new text as follows:

1301.1.1 Alternate compliance path. Systems for nonpotable uses that comply with CSA B805/ICC 805 are deemed to comply with this chapter.

Add new standard(s) follows:

CSA

CSA Group
8501 East Pleasant Valley Road
Cleveland OH 44131-5516

CSA B805-18/ICC 805-2018:

Rainwater Harvesting Systems

Analysis: A review of the standard proposed for inclusion in the code, CSA 805-17/ICC 805-2017, with regard to the ICC criteria for referenced standards (Section 3.6 of CP#28) will be posted on the ICC website on or before April 2, 2018.

Internal ID: 1971

P131-18 Part II

IRC: P2912.1.1 (New), Chapter 44

Proponent: Dave Cantrell, representing The Joint CSA/ICC Rainwater System Design and Installation Consensus Committee (dave.cantrell.codes@gmail.com)

2018 International Residential Code

Add new text as follows:

P2912.1.1 Alternate compliance path. Systems for nonpotable uses that comply with CSA B805/ICC 805 are deemed to comply with Section P2912.

Add new standard(s) follows:

CSA

CSA Group
8501 East Pleasant Valley Road
Cleveland OH 44131-5516

CSA B805-18/ICC 805-2018:

Rainwater Harvesting Systems

Reason:

This proposal adds the CSA B805/ICC 805 Standard as an alternate compliance path for rainwater to be used in nonpotable applications. The Canadian Standards Association and the International Code Council jointly formed the Rainwater System Design and Installation Consensus Committee (IS-RCSDI) in order to create a Rainwater Harvesting Standard for use in North America. Nonpotable rainwater harvesting systems that conform to this Standard will comply with Chapter 13 (IRC Section P2912), thus providing a far more comprehensive guidance document as an alternate compliance path.

While this new Standard addresses rainwater for potable use and stormwater for nonpotable use, neither of which are addressed in Chapter 13 (IRC P2912), including this Standard in Chapter 14 (IRC Chapter 44) would not mandate such uses. However, it will provide code officials with the guidance needed for reviewing and inspecting these types of water reuse systems that are becoming more common with ever-increasing water conservation measures.

Here are some necessary provisions that the committee felt obligated to include in this Standard:

1. This Standard addresses roof surface rainwater and stormwater being used as source water. It addresses rainwater intended for use in nonpotable applications as well as potable applications.
2. Recognizing that the risk to public health increases with the number of persons using a rainwater harvesting system, this Standard provides different methods for protecting water based on the influent water quality, the system, and the application. Stormwater runoff is expected to have a higher likelihood of contamination as a result of its flowing overland. Therefore, this Standard specifies additional treatment process requirements for stormwater runoff and does not cover its use for potable water applications.
3. In order to ensure the consideration of the wide range of variables associated with each site, location, design, and application, this Standard requires that a water safety plan be developed for all rainwater harvesting systems. The water safety plan considers the specific challenges and risks presented by the site and associated impact on source water quality, operation of system components, and the risk associated with the end use.
4. Applications for harvested rainwater are separated into four end use tiers that consider the exposure potential through ingestion, inhalation, and skin contact. It further separates these tiers into two groups, one for single-family residential and one for multifamily, commercial and public facilities.
5. This Standard specifies minimum performance criteria for each end use tier in consideration of the health risk and identifies possible treatment process options to meet the specified performance criteria.
6. Based on the expected source water quality, this Standard establishes suitable water quality parameters that are used to substantiate that the treatment process is operating as intended to produce safe water for the specified end use.

Cost Impact

The code change proposal will not increase or decrease the cost of construction .

The proposed alternate compliance path is an option provided to the user, not a requirement. Therefore, no added cost is mandated to the user of the code.

Analysis: A review of the standard proposed for inclusion in the code, CSA B805-18/ICC 805-2018, with regard to the ICC criteria for referenced standards (Section 3.6 of CP#28) will be posted on the ICC website on or before April 2, 2018.

Internal ID: 1986

P132-18 Part I

IPC: 1301.1.1 (New), Chapter 15

Proponent: Dave Cantrell, representing The Joint CSA/ICC Rainwater System Design and Installation Consensus Committee (dave.cantrell.codes@gmail.com)

2018 International Plumbing Code

Add new text as follows:

1301.1.1 Alternate compliance path. Systems designed for potable uses shall comply with CSA B805/ICC 805.

Add new standard(s) follows:

CSA

CSA Group
8501 East Pleasant Valley Road
Cleveland OH 44131-5516

CSA B805-18/ICC 805-2018:

Rainwater Harvesting Systems

Analysis: A review of the standard proposed for inclusion in the code, CSA 805-18/ICC 805-2018, with regard to the ICC criteria for referenced standards (Section 3.6 of CP#28) will be posted on the ICC website on or before April 2, 2018.

Internal ID: 1981

P132-18 Part II

IRC: P2912.1.1 (New), Chapter 44

Proponent: Dave Cantrell, representing The Joint CSA/ICC Rainwater System Design and Installation Consensus Committee (dave.cantrell.codes@gmail.com)

2018 International Residential Code

Add new text as follows:

P2912.1.1 Alternate compliance path. Systems designed for potable uses shall comply with CSA B805/ICC 805.

Add new standard(s) follows:

CSA

CSA Group
8501 East Pleasant Valley Road
Cleveland OH 44131-5516

CSA B805-18/ICC 805-18:

Rainwater Harvesting Systems

Reason:

This proposal adds the CSA B805/ICC 805 Standard as an alternate compliance path for rainwater to be used in both potable and nonpotable applications. The Canadian Standards Association and the International Code Council jointly formed the Rainwater System Design and Installation Consensus Committee (IS-RCSDI) in order to create a Rainwater Harvesting Standard for use in North America, one that will provide further guidance for rainwater to serve both potable and nonpotable uses.

Chapter 13 (IRC Section P2912) does not address rainwater for potable use, nor does it contain provisions for the use of stormwater for nonpotable use. This Standard provides code officials the guidance needed for reviewing and inspecting these types of water reuse systems that are becoming more common with ever-increasing water conservation measures. For this reason this Standard should be referenced in Chapter 14 (IRC Chapter 44) . It should further be noted that nonpotable rainwater harvesting systems that conform to this Standard will comply with Chapter 13 (Section P2912), thus providing a far more comprehensive guidance document as an alternate compliance path.

Here are some necessary provisions that the committee felt obligated to include in this Standard:

1. This Standard addresses roof surface rainwater and stormwater being used as source water. It addresses rainwater intended for use in nonpotable applications as well as potable applications.
2. Recognizing that the risk to public health increases with the number of persons using a rainwater harvesting system, this Standard provides different methods for protecting water based on the influent water quality, the system, and the application. Stormwater runoff is expected to have a higher likelihood of contamination as a result of its flowing overland. Therefore, this Standard specifies additional treatment process requirements for stormwater runoff and does not cover its use for potable water applications.
3. In order to ensure the consideration of the wide range of variables associated with each site, location, design, and application, this Standard requires that a water safety plan be developed for all rainwater harvesting systems. The water safety plan considers the specific challenges and risks presented by the site and associated impact on source water quality, operation of system components, and the risk associated with the end use.
4. Applications for harvested rainwater are separated into four end use tiers that consider the exposure potential through ingestion, inhalation, and skin contact. It further separates these tiers into two groups, one for single-family residential and one for multifamily, commercial and public facilities.
5. This Standard specifies minimum performance criteria for each end use tier in consideration of the health risk and identifies possible treatment process options to meet the specified performance criteria.
6. Based on the expected source water quality, this Standard establishes suitable water quality parameters that are used to substantiate that the treatment process is operating as intended to produce safe water for the specified end use.

Cost Impact

The code change proposal will not increase or decrease the cost of construction .

The proposed alternate compliance path is an option provided to the user, not a requirement. Therefore, not added cost is mandated to the user of the code.

Analysis: A review of the standard proposed for inclusion in the code, CSA B805-18/ICC 805-2018, with regard to the ICC criteria for referenced standards (Section 3.6 of CP#28) will be posted on the ICC website on or before April 2, 2018.

Internal ID: 1988

P133-18 Part I

IPC: Chapter 14, 1401.1, 1401.2, 1401.3, 1401.4, 1401.5, 1401.6, 1402.1, 1402.3, TABLE 1402.3, 1403.1

Proponent: Brent Mecham, Irrigation Association, representing Irrigation Association (brentmecham@irrigation.org)

THIS IS A 2 PART CODE CHANGE PROPOSAL. PART I WILL BE HEARD BY THE IPC COMMITTEE. PART II WILL BE HEARD BY THE IRC-PLUMBING COMMITTEE. SEE THE TENTATIVE HEARING ORDERS FOR THESE COMMITTEES.

2018 International Plumbing Code

Revise as follows:

CHAPTER 14 SUBSURFACE ~~LANDSCAPE IRRIGATION GRAY WATER SOIL ABSORPTION~~ SYSTEMS

1401.1 Scope. The provisions of this chapter shall govern the materials, design, construction and installation of subsurface ~~landscape irrigation graywater soil absorption~~ systems connected to nonpotable water from on-site water reuse systems.

1401.2 Materials. Above-ground drain, waste and vent piping for subsurface ~~landscape irrigation graywater soil absorption~~ systems shall conform to one of the standards listed in Table 702.1. Subsurface ~~landscape irrigation graywater soil absorption~~ systems, underground building drainage and vent pipe shall conform to one of the standards listed in Table 702.2.

1401.3 Tests. Drain, waste and vent piping for subsurface ~~landscape irrigation graywater soil absorption~~ systems shall be tested in accordance with Section 312.

1401.4 Inspections. Subsurface ~~landscape irrigation graywater soil absorption~~ systems shall be inspected in accordance with Section 107.

1401.5 Disinfection. Disinfection shall not be required for on-site nonpotable water reuse for subsurface ~~landscape irrigation graywater soil absorption~~ systems.

1401.6 Coloring. On-site nonpotable water reuse for subsurface ~~landscape irrigation graywater soil absorption~~ systems shall not be required to be dyed.

1402.1 Sizing. The system shall be sized in accordance with the sum of the output of all water sources connected to the subsurface ~~irrigation gray water soil absorption~~ system. Where gray water collection piping is connected to subsurface landscape irrigation systems, gray water output shall be calculated according to the gallons-per-day-per-occupant number based on the type of fixtures connected. The gray water discharge shall be calculated by the following equation:

$$C = A \times B \text{ (Equation 14-1)}$$

where:

A = Number of occupants:

Residential-Number of occupants shall be determined by the actual number of occupants, but not less than two occupants for one bedroom and one occupant for each additional bedroom.

Commercial-Number of occupants shall be determined by the International Building Code.

B = Estimated flow demands for each occupant:

Residential-25 gallons per day (94.6 lpd) per occupant for showers, bathtubs and lavatories and 15 gallons per day (56.7 lpd) per occupant for clothes washers or laundry trays.

Commercial-Based on type of fixture or water use records minus the discharge of fixtures other than those discharging gray water.

C = Estimated gray water discharge based on the total number of occupants.

1402.3 Subsurface ~~landscape irrigation graywater soil absorption~~ site location. The surface grade of all soil absorption systems shall be located at a point lower than the surface grade of any water well or reservoir on the same or adjoining lot. Where this is not possible, the site shall be located so surface water drainage from the site is not directed toward a well or reservoir. The soil absorption system shall be located with a minimum horizontal distance

between various elements as indicated in Table 1402.3. Private sewage disposal systems in compacted areas, such as parking lots and driveways, are prohibited. Surface water shall be diverted away from any soil absorption site on the same or neighboring lots.

**TABLE 1402.3
LOCATION OF SUBSURFACE IRRIGATION-GRAYWATER SOIL ABSORPTION SYSTEM**

ELEMENT	MINIMUM HORIZONTAL DISTANCE	
	Storage tank (feet)	Absorption field (feet)
Buildings	5	2
Lot line adjoining private property	5	5
Water wells	50	100
Streams and lakes	50	50
Seepage pits	5	5
Septic tanks	0	5
Water service	5	5
Public water main	10	10

For SI: 1 foot = 304.8 mm.

1403.1 Installation. Absorption systems shall be installed in accordance with Sections 1403.1.1 through 1403.1.5 ~~to provide landscape irrigation without surfacing of water.~~

Internal ID: 1251

P133-18 Part II

IRC: P3009, P3009.1, P3009.2, P3009.3, P3009.4, P3009.5, P3009.6, P3009.7, P3009.9, TABLE P3009.9, P3009.10

Proponent: Brent Mecham, Irrigation Association, representing Irrigation Association (brentmecham@irrigation.org)

2018 International Residential Code

Revise as follows:

SECTION P3009 SUBSURFACE ~~LANDSCAPE IRRIGATION~~ GRAY WATER SOIL ABSORPTION SYSTEMS

P3009.1 Scope. The provisions of this section shall govern the materials, design, construction and installation of subsurface ~~landscape irrigation~~ gray water soil absorption systems connected to nonpotable water from on-site water reuse systems.

P3009.2 Materials. Above-ground drain, waste and vent piping for subsurface ~~landscape irrigation~~ gray water soil absorption systems shall conform to one of the standards indicated in Table P3002.1(1). Subsurface ~~landscape irrigation~~ gray water soil absorption, underground building drainage and vent pipe shall conform to one of the standards indicated in Table P3002.1(2).

P3009.3 Tests. Drain, waste and vent piping for subsurface ~~landscape irrigation~~ gray water soil absorption systems shall be tested in accordance with Section P2503.

P3009.4 Inspections. Subsurface ~~landscape irrigation~~ gray water soil absorption systems shall be inspected in accordance with Section R109.

P3009.5 Disinfection. Disinfection shall not be required for on-site nonpotable reuse water for subsurface ~~landscape irrigation~~ gray water soil absorption systems.

P3009.6 Coloring. On-site nonpotable reuse water used for subsurface ~~landscape irrigation~~ gray water soil absorption systems shall not be required to be dyed.

P3009.7 Sizing. The system shall be sized in accordance with the sum of the output of all water sources connected to the subsurface ~~irrigation system~~ gray water soil absorption system. Where gray-water collection piping is connected to subsurface ~~landscape~~ gray water soil absorption irrigation systems, gray-water output shall be calculated according to the gallons-per-day-per-occupant (liters per day per occupant) number based on the type of fixtures connected. The gray- water discharge shall be calculated by the following equation:

$$C = A \times B$$

(Equation 30-1)

where:

A = Number of occupants:

Number of occupants shall be determined by the actual number of occupants, but not less than two occupants for one bedroom and one occupant for each additional bedroom.

B = Estimated flow demands for each occupant:

25 gallons (94.6 L) per day per occupant for showers, bathtubs and lavatories and 15 gallons (56.7 L) per day per occupant for clothes washers or laundry trays.

C = Estimated gray-water discharge based on the total number of occupants.

P3009.9 Subsurface ~~landscape irrigation~~ gray water soil absorption system site location. The surface grade of soil absorption systems shall be located at a point lower than the surface grade of any water well or reservoir on the same or adjoining lot. Where this is not possible, the site shall be located so surface water drainage from the site is not directed toward a well or reservoir. The soil absorption system shall be located with a minimum horizontal distance between various elements as indicated in Table P3009.9. Private sewage disposal systems in compacted areas, such as parking lots and driveways, are prohibited. Surface water shall be diverted away from any soil absorption site on the same or neighboring lots.

**TABLE P3009.9
LOCATION OF SUBSURFACE IRRIGATION GRAY WATER SOIL ABSORPTION SYSTEM**

ELEMENT	MINIMUM HORIZONTAL DISTANCE	
	STORAGE TANK(feet)	IRRIGATION DISPOSAL ABSORPTION FIELD(feet)
Buildings	5	2
Lot line adjoining private property	5	5
Water wells	50	100
Streams and lakes	50	50
Seepage pits	5	5
Septic tanks	0	5
Water service	5	5
Public water main	10	10

For SI: 1 foot = 304.8 mm.

P3009.10 Installation. Absorption systems shall be installed in accordance with Sections P3009.10.1 through P3009.11 ~~to provide landscape irrigation without surfacing of water.~~

Reason:

The proposed changes better identifies the content of the chapter from irrigation systems to soil absorption systems. The technical requirements can remain as written.

While gray water is a good source of water for maintaining plants, the provisions in this section do not adequately describe the technical aspects for use in an irrigation system. The technical requirements are addressing the soil's ability to absorb water and percolate into the soil. There are no requirements mentioned about considering the needs of plants which is an essential part of an irrigation system.

When gray water is to be used for irrigation, then chapters that are in the International Green Construction Code include better technical requirements for irrigation systems and those should be followed.

Cost Impact

The code change proposal will not increase or decrease the cost of construction .

The proposed changes only better identify the name of the chapter and do not include any technical changes that would affect construction costs

Internal ID: 3503

PSD1-18

IPSDC: 101.2, 101.3, 107.2, 107.2.1, 107.2.2, 1 (New), 304, 304.1, 304.1.1, 304.2, 304.3, 304.4, 304.5, 304.6, 504.5, 802.1, 802.4, 802.5, 802.10, 805.3, 805.6, Chapter 11, 1101.1, 1101.2, 1202.4, Chapter 14

Proponent: Dennis Hallahan, Infiltrator Water Technologies, representing National Onsite Wastewater Recycling Association (dhallahan@infiltratorwater.com)

2018 International Private Sewage Disposal Code

Revise as follows:

[A] 101.2 Scope. Septic tank and effluent absorption systems or other treatment tank and effluent disposal systems shall be permitted where a public sewer is not available to the property served. ~~Unless specifically approved, the private sewage disposal system of each building shall be entirely separate from and independent of any other building.~~ The use of a common system or a system on a parcel other than the parcel where the structure is located shall be subject to the full requirements of this code as for systems serving public buildings.

[A] 101.3 Public sewer connection. Where public sewers become available to the premises served, the use of the *private sewage disposal system* shall be discontinued within that period of time required by law, but such period shall not exceed one year. The building sewer shall be disconnected from the *private sewage disposal system* and connected to the public sewer.

Exception: Where approved by the code official for such reasons as excessive cost or project difficulty, or where the existing system does not pose a health threat or is code compliant, then connection to the public sewer shall not be required.

[A] 107.2 Special inspections. Special inspections of alternative ~~engineered~~-design *private sewage disposal systems* shall be conducted in accordance with Sections 107.2.1 and 107.2.2.

[A] 107.2.1 Periodic inspection. The registered design professional or designated inspector shall periodically inspect and observe the alternative ~~engineered~~-design to determine that the installation is in accordance with the approved plans. Discrepancies shall be brought to the immediate attention of the *private sewage disposal system* contractor for correction. Records shall be kept of all inspections.

[A] 107.2.2 Written report. The registered design professional shall submit a final report in writing to the code official upon completion of the installation, certifying that the alternative ~~engineered~~-design conforms to the approved construction documents. A notice of approval for the *private sewage disposal system* shall not be issued until a written certification has been submitted.

SECTION 304 ALTERNATIVE ~~ENGINEERED~~-DESIGN

304.1 Alternative ~~engineered~~ design. The design, documentation, inspection, testing and approval of an alternative ~~engineered~~-design *private sewage disposal system* shall comply with Sections 304.1.1 through 304.6.

304.1.1 Design criteria. An alternative ~~engineered~~-design shall conform to the intent of the provisions of this code and shall provide an equivalent level of quality, strength, effectiveness, fire resistance, durability and safety. Material, equipment or components shall be designed and installed in accordance with the manufacturer's instructions.

304.2 Submittal. The registered design professional shall indicate on the permit application that the *private sewage disposal system* is an alternative ~~engineered~~-design. The permit and permanent permit records shall indicate that an alternative ~~engineered~~-design was part of the approved installation.

304.3 Technical data. The registered design professional shall submit sufficient technical data to substantiate the proposed alternative ~~engineered~~-design and to prove that the performance meets the intent of this code.

304.4 Construction documents. The registered design professional shall submit to the code official two complete sets of signed and sealed construction documents for the alternative ~~engineered~~-design.

304.5 Design approval. Where the code official determines that the alternative ~~engineered~~-design conforms to the intent of this code, the *private sewage disposal system* shall be approved. If the alternative ~~engineered~~-design is not approved, the code official shall notify the registered design professional in writing, stating the reasons therefor.

304.6 Inspection and test. The alternative ~~engineered~~ design shall be inspected in accordance with the requirements of Section 107.

Add new text as follows:

504.5 Thermoplastic Tanks. Thermoplastic tanks shall conform to IAPMO Z1000, IAPMO IGC 262-2013 or CSA B66-16.

Revise as follows:

504.5 6 Manholes. ~~Manhole collars and extensions shall be of the same material as the tank. Manhole covers shall be of concrete, steel, cast iron,~~ thermoplastic or other approved material.

802.1 General. Septic tanks shall be fabricated or constructed of welded steel, monolithic concrete, fiberglass, thermoplastic or an approved material. Tanks shall be water tight and fabricated to constitute an individual structure, and shall be designed and constructed to withstand anticipated loads. The design of prefabricated septic tanks shall be approved. Plans for site-constructed concrete tanks shall be approved prior to construction.

805.3 Construction. Holding tanks shall be constructed of welded steel, monolithic concrete, glass-fiber-reinforced polyester, thermoplastic or other approved materials.

802.4 Manholes. Each compartment of a tank shall be provided with not fewer than one manhole opening located over the inlet or outlet opening, and such opening shall be not less than 24 inches (610 mm) square or 24 inches (610 mm) in diameter. Where the inlet compartment of a septic tank exceeds 12 feet (3658 mm) in length, an additional manhole shall be provided over the baffle wall. Manholes shall terminate not greater than 6 inches (152 mm) below the ground surface. ~~Manholes shall be of the same material as the tank. Steel tanks shall have not less than a 2-inch (51 mm) collar for the manhole extensions permanently welded to the tank. The manhole extension on fiberglass tanks shall be of the same material as the tank and an integral part of the tank. The collar shall be not less than 2 inches (51 mm) high.~~

802.5 Manhole covers. Manhole risers shall be provided with a fitted, water-tight cover of concrete, steel, cast iron, thermoplastic or other approved material capable of withstanding all anticipated loads. Manhole covers terminating above grade shall have an approved locking device.

805.6 Manholes. Each tank shall be provided with either a manhole not less than 24 inches (610 mm) square or with a manhole having a 24-inch (610 mm) inside diameter extending not less than 4 inches (102 mm) above ground. Finished grade shall be sloped away from the manhole to divert surface water from the manhole. Each manhole cover shall have an effective locking device or tamper resistant screw fastener. Service ports in manhole covers shall be not less than 8 inches (203 mm) in diameter and shall be 4 inches (102 mm) above finished grade level. The service port shall have an effective locking cover or a brass cleanout plug.

802.10 Manhole riser joints. Joints on concrete risers and manhole covers shall be tongue-and-groove or shiplap type and sealed water tight using neat cement, mortar or bituminous compound. Joints on steel risers shall be welded or flanged and bolted and water tight. Steel manhole extensions shall be bituminous coated both inside and outside. Methods of attaching fiberglass and thermoplastic risers shall be water tight and approved.

CHAPTER 11 ~~RESIDENTIAL~~ ADVANCED WASTE-WATER TREATMENT SYSTEMS

1101.1 Scope. The provisions of this chapter shall govern ~~residential~~ advanced wastewater treatment systems.

1101.2 ~~Residential~~ Advanced waste-water treatment systems. The regulations for materials, design, construction and performance shall comply with NSF 40, NSF 245 or NSF 350, as applicable.

1202.4 Other inspections. In addition to the required inspection prior to backfilling, the code official shall conduct any other inspections deemed necessary to determine compliance with this code. Including inspections to verify adequate ongoing performance of the system as required.

Add new standard(s) follows:

NSF

NSF International
789 N. Dixboro Road
Ann Arbor MI 48105

PSD2

NSF/ANSI 245 - 2013:

Wastewater Treatment Systems - Nitrogen Reduction

NSF/ANSI 350-2014:

Onsite Residential and Commercial Water-Reuse Treatment Systems

CSA

CSA Group
8501 East Pleasant Valley Road
Cleveland OH 44131-5516

B602—15:

Mechanical Couplings for Drain, Waste, and Vent Pipe and Sewer Pipe

B66-16:

Design, material, and manufacturing requirements for prefabricated septic tanks and sewage holding tanks

IAPMO IAPMO/ANSI Z1000-2013 Prefabricated Septic Tanks

IAPMO IAPMO IGC 262-2013 Corrugated Thermoplastic Tanks

Reason:

101.1 Cluster system designs are very common, can serve more than one building, and allow additional solutions to protect public health.

101.3 A private sewage treatment system can provide wastewater treatment similar to a public sewer.

107.2, 107.2.1, 304, 304.1, 304.1.1, 304.2, 304.3, 304.4, 304.5, 304.6:

In the 2015 International Private Sewage Disposal Code, the phrase Alternative Engineered Design is stated 16 times, including the table of contents and the index, therefore there are additional locations to remove this term. The Code does not define an "Alternative Engineered Design", nor does it provide guidance as to what constitutes an Alternative Engineered Design. Many states, provinces, and international programs allow registered sanitarians or environmental specialists to design sewage treatment systems, hence NOWRA requests that the term "engineered" be removed from this section and others.

New Section 504.5 Thermoplastic tanks are approved by all 50 states and provinces and are common internationally.

504.5 (this section number should be moved up to 504.6) Thermoplastic collars and extensions are approved by all 50 states. It is common practice to have materials differing than the tank. For example, thermoplastic extensions are cast into concrete tanks.

802.1 Thermoplastic tanks are approved by all 50 states and provinces and are common internationally.

802.4 Thermoplastic collars and manhole extensions are approved by all 50 states and provinces. It is common practice to have materials differing than the tank.

802.5, 802.10, & 805.3 Thermoplastic materials have been in use for many years and are approved in all states and provinces.

805.6 Tamper resistant screws are standard practice are approved in many state and provincial codes.

11 The title is proposed to change to Advanced Waste-Water Treatment Systems because this is the most common industry term. The term "Residential" is removed because the facilities served can be residential or commercial.

1101.1 Change consistent with Section 11 above.

1101.2 The term Residential is removed to be consistent with Section 11 above. Available new standards are NSF 245 and NSF 350 to address nutrient removal and reuse.

1202.4 As the decentralized wastewater industry progresses, many states, provinces, and counties require operational permits for private sewage treatment systems, both conventional and/or advanced waste-water treatment systems.

Cost Impact

The code change proposal will decrease the cost of construction .

101.1 By allowing other solutions to be considered the cost may be lowered.

101.3 The private sewage treatment system option may have a lower cost.

107.2, 107.2.1, 304, 304.1, 304.1.1, 304.2, 304.3, 304.4, 304.5, & 304.6:

Allowing other certified professionals to design systems will increase choices and may lower costs.

New Section 504.5 The inclusion of Thermoplastic tanks will increase choices and may offer cost savings in materials and labor.

504.5 The inclusion of thermoplastic collars and extensions will increase choices and may offer cost savings.

802.1 The inclusion of thermoplastic materials will increase choices and may offer cost savings.

802.4 The inclusion of thermoplastic materials will increase choices and may offer cost savings.

802.5 The inclusion of thermoplastic materials will increase choices and may offer cost savings.

802.10 The inclusion of thermoplastic materials will increase choices and may offer cost savings.

805.3 The inclusion of thermoplastic materials will increase choices and may offer cost savings.

805.6 The inclusion of tamper resistant screws will increase choices and may offer cost savings.

11 The code change proposal will have no impact on the cost of construction.

1101.1 The code change proposal will have no impact on the cost of construction.

1101.2 For the jurisdictions that require treatment in accordance with these standards, the code change proposal will have no impact on the cost of construction.

1202.4 For the jurisdictions that require operational permits, the code change proposal will have no impact on the cost of construction.

Analysis: A review of the standard proposed for inclusion in the code, NSF 245-2013, IAPMO Z1000-2013, IAPMO IGC 262-2013 and CSA B66-16 with regard to the ICC criteria for referenced standards (Section 3.6 of CP#28) will be posted on the ICC website on or before April 2, 2018. The referenced standard, NSF 350-2014, is currently referenced in other 2018 I-codes.

Internal ID: 1277

PSD2-18

IPSDC: 504.2.1, 504.2.2 (New), 504.2.3 (New), 504.5, 504.2.1 (New), Chapter 14

Proponent: William Hall, Portland Cement Association, representing Alliance For Concrete Codes and Standards (jhall@cement.org); Eric Carleton, representing National Precast Concrete Association (ecarleton@precast.org)

2018 International Private Sewage Disposal Code

Revise as follows:

504.2.1 Precast concrete and site-constructed tanks. Precast concrete septic tanks and square or rectangular holding tanks shall conform to ASTM ~~C913~~C1227. The floor and sidewalls of a site-constructed concrete tank shall be monolithic, except a construction joint is permitted in the lower 12 inches (305 mm) of the sidewalls of the tank. The construction joint shall have a keyway in the lower section of the joint. The width of the keyway shall be approximately 30 percent of the thickness of the sidewall with a depth equal to the width. A continuous water stop or baffle not less than 56 inches (1422 mm) wide shall be set vertically in the joint, embedded one-half its width in the concrete below the joint with the remaining width in the concrete above the joint. The water stop or baffle shall be copper, neoprene, rubber or polyvinyl chloride designed for this specific purpose. Joints between the concrete septic tank and the tank cover and between the septic tank cover and manhole riser shall be tongue and groove or shiplap-type and sealed water tight using cement, mortar or bituminous compound. Connections between concrete septic tanks and holding tanks shall conform to ASTM C1644

Add new text as follows:

504.2.2 Precast Circular Concrete. Pre-cast circular concrete;manhole riser sections, collars circular dosing or pump chambers, and holding tanks shall conform to ASTM C478

504.2.3 Pre-cast square or rectangular concrete. Precast square or rectangular concrete; riser sections, collars, dosing or pump chambers shall conform to ASTM C913

Revise as follows:

504.5 Manholes. ~~Manhole collars and extensions shall be of the same material as the tank. Manhole covers shall be of concrete, steel, cast iron or other approved material.~~an approved material that maintains a watertight seal.

Add new text as follows:

504.2.1 Manhole Covers. Manhole covers shall be of an approved material that maintains a watertight seal. When required by the jurisdiction having authority each manhole cover shall have an effective locking device.

Add new standard(s) follows:

CHAPTER 14 REFERENCED STANDARDS

ASTM

ASTM International
100 Barr Harbor Drive, P.O. Box
C700
West Conshohocken PA 19428-
2959

C478-15a:

Specification for Circular Precast Reinforced Concrete Manhole Sections

C1644-06:

Specification for Resilient Connectors Between Reinforced Concrete On-Site Wastewater Tanks and Pipes

Reason:

Section 504.2 Precast concrete and site-constructed tanks - because it is suggested to reference the specific components based on their shape, function and individual ASTM reference, it was felt that separate sections for each precast concrete shape helped clarify the code references and applications.

Section 504.2.1. The current edition specifies the ASTM C913 Specification for Precast Concrete Water and Wastewater Structures standard, which may be appropriate for many precast structures utilized for water and wastewater applications including other precast items within this code. However, the suggested ASTM C1227 Specification for Precast Concrete Septic Tanks provides the specific requirements for septic tank materials, fabrication and quality testing. Additionally, the provisions within C1227 are appropriate for the sewage holding tank applications described within Section 805. To provide best uniform assurance of water tightness a resilient connector between tank and pipe is required. The standard for this product is ASTM C1644 Specification for Resilient Connectors Between Reinforced Concrete On-Site Wastewater Tanks and Pipes.

Section 504.2.2 Included within this code are precast concrete components that are circular shaped. Those components are referenced as risers for tanks or holding structures. Consequently, the appropriate ASTM standard for describing these components are best defined and included within ASTM C478 Specification for Circular Precast Reinforced Concrete Manhole Sections.

Section 504.2.3 Additionally, there are available precast risers, collars, dosing or pump chambers which are not circular nor a septic tank. These components are best described and fall under the umbrella of ASTM c913 Specification for Precast Concrete Water and Wastewater Structures.

Section 504.5 Manholes - The existing language requires the use of the same materials for the extension sections (collars, risers, etc.) upon the flattop lid. Current septic tank fabrication methods have successfully fabricated hybrid systems which utilize precast concrete for the tank chamber for the attributes it possesses and other materials which are directly cast into the flattop lid as the riser section. Such materials could be cast-iron frames, or virgin resin pvc components.

Section 504.5.1. This new provision clarifies the cover is also to be watertight like the balance of the system and not the weak link. Additional language is added as a response to an identified safety issue regarding unauthorized access to septic systems, primarily by children, leading to dangerous or life-threatening situations. The proposed language as similarly described within section 805.6, provides guidance and authority for local agencies to require locking apparatus on septic tank access covers if deemed appropriate for their jurisdiction.

Cost Impact

The code change proposal will not increase or decrease the cost of construction .

This proposal only clarifies the code by referring to the correct reference standard and separates circular from square or rectangular pre-cast components.

Analysis: A review of the standard proposed for inclusion in the code, ASTM C478a-15a and ASTM ASTM C1644-06, with regard to the ICC criteria for referenced standards (Section 3.6 of CP#28) will be posted on the ICC website on or before April 2, 2018. The standard ASTM C1227-13 is already in the current edition of the code.

Internal ID: 663

PSD3-18

IPSDC: 802.1

Proponent: William Hall, Portland Cement Association, representing Alliance For Concrete Codes and Standards (jhall@cement.org); Eric Carleton, National Precast Concrete Association, representing National Precast Concrete Association (ecarleton@precast.org); Stephen Szoke, representing American Concrete Institute (steve.szoke@concrete.org)

2018 International Private Sewage Disposal Code

Revise as follows:

802.1 General. Septic tanks shall be fabricated or constructed of welded steel, monolithic concrete, fiberglass or an approved material. Tanks shall be water tight and fabricated to constitute an individual structure, and shall be designed and constructed to withstand anticipated ~~loads.~~ hydraulic and structural loads including soil, hydrostatic, flotation and traffic when conditions exist. When required by the code official, the design of septic tanks shall be by a registered professional engineer within the state or province of the septic tank installation. The design of prefabricated septic tanks shall be approved. Plans for site-constructed concrete tanks shall be approved prior to construction.

Reason:

Section 802.1 General. The current language ignores clarifying that the critical components of septic tank design is both hydraulic for correct sizing and structural for continued function of the tank without failure. The listing of specific loads is for the benefit of the reviewer to be aware that each site is unique and requires the designer to be aware and acknowledge those variable conditions have been analyzed.

Cost Impact

The code change proposal will not increase or decrease the cost of construction .

The proposed language is only a clarification of the code requirements and therefore, does not impact the cost of construction.

Internal ID: 669

PSD4-18

IPSDC: 802.4

Proponent: William Hall, Portland Cement Association, representing Alliance For Concrete Codes and Standards (jhall@cement.org); Stephen Szoke, representing American Concrete Institute (steve.szoke@concrete.org); Eric Carleton, National Precast Concrete Association, representing National Precast Concrete Association (ecarleton@precast.org)

2018 International Private Sewage Disposal Code

Revise as follows:

802.4 Manholes. Each compartment of a tank shall be provided with not fewer than one manhole opening located over the inlet or outlet opening, and such opening shall be not less than 24 inches (610 mm) square or 24 inches (610 mm) in diameter. Where the inlet compartment of a septic tank exceeds 12 feet (3658 mm) in length, an additional manhole shall be provided over the baffle wall. Manholes shall terminate not greater than 6 inches (152 mm) below the ground surface. ~~Manholes shall be of the same material as the tank.~~ Steel tanks shall have not less than a 2-inch (51 mm) collar for the manhole extensions permanently welded to the tank. The manhole extension on fiberglass tanks shall be of the same material as the tank and an integral part of the tank. The collar shall be not less than 2 inches (51 mm) high.

Reason:

Same as section 504.5, the existing language requires the use of same materials for the extension sections upon the flattop lid. Current septic tank fabrication methods have successfully fabricated hybrid systems which utilize precast concrete for the tank chamber for the attributes it possesses and other materials which are directly cast into the flat top lid for the riser section such as cast-iron frames and covers.

Cost Impact

The code change proposal will not increase or decrease the cost of construction .

The proposed language is only a clarification of the code requirements and therefore, does not impact the cost of construction.

Internal ID: 675

PSD5-18

IPSDC: Chapter 11, SECTION 1101, 1101.1, 1101.2, 1101.3 (New), 1101.4 (New), 1101.5 (New), 1101.5.1 (New), 1101.5.2 (New), 1101.5.3 (New), 1101.5.4 (New), 1101.6 (New), 1101.7 (New), 1101.7.1 (New), 1101.7.2 (New), SECTION 1102 (New), 1102.1 (New), 1102.2 (New), 1102.2.1 (New), 1102.2.2 (New), 1102.2.3 (New), 1102.2.4 (New), 1102.2.5 (New), SECTION 1103 (New), 1103.1 (New), 1103.2 (New), 1103.2.1 (New), 1103.2.2 (New), 1103.2.3 (New), 1103.2.4 (New), 1103.2.5 (New), 1103.3 (New), 1103.4 (New), Chapter 14

Proponent: Scott Hetrick, representing Norweco, Inc. (shetrick@norweco.com)

2018 International Private Sewage Disposal Code

Revise as follows:

CHAPTER 11 ADVANCED RESIDENTIAL WASTE-WATER-WASTEWATER TREATMENT SYSTEMS

SECTION 1101 GENERAL

1101.1 Scope. The provisions of this chapter shall govern advanced residential waste-water-wastewater treatment systems.

~~1101.2 Residential waste-water treatment systems.~~ Advanced residential wastewater treatment systems (ATUs). The regulations for materials, design, construction and performance of advanced residential wastewater treatment systems shall comply with NSF 40, 46, 245 or 350 as applicable. Products certified to these standards shall be considered for use where residential building lots have size or soil limitations that prevent the use of septic tanks, the existing onsite system has failed and is causing a public health nuisance, or the building owner wants improved wastewater treatment.

Advanced residential wastewater treatment systems or any other product that displays and promotes the NSF Mark shall be subject to required service obligations under the provisions of the NSF listing, regardless of the treatment technology.

Add new text as follows:

1101.3 Treatment tank construction. Advanced treatment system tankage for residential use shall be manufactured from precast concrete, plastic or fiberglass.

1101.4 Description. Where soils are not ideal for leaching such as soils having high perched water tables or limiting layers both of which negatively affect the transport of treated effluent into the ground, advanced residential wastewater treatment (ATU) systems shall be considered for overcoming soil limitations or inadequate lot size. Advanced residential wastewater treatment systems shall include pretreatment followed by secondary treatment. Tertiary treatment and disinfection shall be required where soil limitations necessitate a greater level of treatment.

1101.5 Daily design flow. The owner or owner's agent shall provide information to the Board of Health or system designer about the source of sewage from the dwelling or structures to be served by an advanced residential wastewater treatment system so as to document system design flow and waste strength . Where required by the Board of Health, building and plumbing plans including plumbing fixture details and other information shall be submitted. The daily design flow estimate for an advanced wastewater treatment system shall comply with Sections 1101.5.1 through 1101.5.4, as applicable.

1101.5.1 Flow per bedroom. The daily design flow for an advanced residential wastewater treatment system shall be 150 gallons per bedroom per day and not less than a total of 300 gallons per day except where conditions described in Sections 1101.5.2 or 1101.5.3 require greater or lesser flow, respectively.

1101.5.2 Non-residential use systems. For an advanced wastewater treatment system for non-residential use, daily design flow shall be determined in accordance with Table 802.7.2 of this code or an alternative daily design flow established by the Board of Health. Where required by the Board of Health, flow monitoring data in addition to or in place of the minimum daily design flow requirements in Table 802.7.2 shall be provided. Where flow monitoring is used as the method of determining daily design flows, the daily design flow shall be not less than 1.5 times the measured average daily flows.

For non-residential use systems, effluent storage shall be permitted to avoid exceeding 1,500 gallons per day daily design loading provided that the peak design flow does not exceed 6,000 gallons per day. Where effluent is stored to avoid exceeding the 1,500 gallons per day daily design flow limit, the design shall use timed dosing and the

appropriate tank capacity to store effluent during peak flows.

1101.5.3 Anticipated increased flows. An increase in the daily design flow for an advanced wastewater treatment system shall be required by the Board of Health where there is an indication that the flows established in accordance with Sections 1101.5.1 or 1101.5.2 of the code will be exceeded. Any required increase in daily flow shall be documented on the installation permit and operation permit.

1101.5.4 Anticipated decreased flows. A reduction in the daily design flow for an advanced wastewater treatment system shall be permitted to be approved by the Board of Health provided that information is submitted indicating conditions that justify reduced flows such as low flow fixtures, alternative toilets or other circumstances that support a reduction in daily design flow. Justification for a proposed reduction in daily design flow shall be included in the site review application and, if approved, shall be documented on the installation permit and operation permit. Where actions are taken to reduce the flows to an advanced wastewater treatment system, the design shall address increased waste strength caused by the reduced flows.

1101.6 Influent wastewater strength. The influent wastewater strength for an advanced residential wastewater treatment system shall be determined for design purposes. Wastewater shall be considered typical residential strength where the 30 day averages have all of the following parameters:

1. BOD₅ not exceeding 300 mg/l.
2. TSS not exceeding 350 mg/l.
3. Fats, oils and grease (FOG) not exceeding 25 mg/l.

Wastewater strength estimates for non-residential use treatment systems shall be determined by the Board of Health or system designer using information provided by the owner or the owner's agent.

1101.7 System design. Designers and designs of sewage treatment system (STS) shall be in accordance with Sections 1101.7.1 and 1101.7.2.

1101.7.1 Preparation and submittal. STS designs shall be prepared and submitted by persons capable of reviewing the soil evaluation, site conditions, information provided by the building owner. Such designs shall be in accordance with this code and shall facilitate the choice of an appropriate, site specific STS and complete the STS design in compliance with Section 1101.7.2. Designers shall be knowledgeable of the requirements of this section and obtain education as necessary or required by manufacturer for all STS technologies they are responsible for designing. Designers shall complete the STS design either while acting as an agent of a Board of Health, or acting as an independent agent of the building owner. A Board of Health employing staff qualified to prepare STS designs shall be permitted to charge a fee for the preparation of the design including associated costs before or after the design is created.

1101.7.2 Required tasks. For the purposes of this section, STS designers shall demonstrate the ability to perform the following tasks required for STS designs through the submission of complete and accurate designs to the Board of Health by performing all of the following, where necessary:

1. Estimate STS flows including daily design flows and any expected variations, and estimate pollutant concentrations and mass loads exceeding typical residential sewage strength.
2. Interpret and evaluate all site-specific information including the soil evaluation, site conditions, site prohibitions and information provided by the owner to determine feasible STS options that will meet the requirements of this section.
3. Evaluate site hydraulics and understand how the proposed STS integrates with the site topography and grade to site the STS.
4. Select devices and components capable of meeting performance requirements based on knowledge of these rules and STS technologies approved by the director of health.
5. Provide approximate installation and operation costs of feasible STS options to assist the owner in selection of the STS to design.
6. Prepare a detailed design which fully complies with this section.
7. Delineate by staking or flagging the proposed soil absorption areas on the site as they relate to topography and contour.
8. Be available to clarify any questions with and make adjustments to the system design, layout or operational concerns. Be available to meet with the owner, soil scientist, installer, service provider

or local health department during, prior and after the installation.

9. Either perform a site visit or have his designee perform a site visit where the STS is to be located during the design process.

SECTION 1102 EFFLUENT QUALITY FOR SOIL-BASED DISCHARGE

1102.1 General. Advanced residential wastewater treatment systems shall be permitted for use in conjunction with any soil based disposal method including gravity pipe and stone, chambers, sand mounds, pressurized mounds, at grade mounds, drip irrigation, spray irrigation, constructed wetlands and any other soil based dispersal system that has been reviewed and approved by the Board of Health.

1102.2 Effluent quality standards. Advanced residential wastewater treatment systems shall comply with the performance based effluent quality standards in Sections 1102.2.1 through 1102.2.5, as applicable, before the system can be considered for approval by the director or Board of Health for reductions in soil absorption area sizing, soil depth credits, nutrient reduction or reduction of high strength waste before distribution to a soil absorption component. A soil absorption component meeting the requirements of this code shall be installed after the advanced residential wastewater treatment system.

1102.2.1 CBOD₅ and TSS.

Treatment system effluent quality shall comply the following requirements for carbonaceous 5-day biochemical oxygen demand (CBOD₅) and total suspended solids (TSS) as demonstrated by 30 day averages in an NSF 40 certification report:

1. CBOD₅ not exceeding 25 mg/l.
2. TSS not exceeding 30 mg/L.

1102.2.2 Fecal coliform and E. coli. Soil depth credits for the disposal system shall be granted based on the following 30 day geometric mean effluent requirements:

1. Fecal coliform not exceeding 10,000 CFU/100ml, or E. coli not exceeding 5,150 CFU/100ml for a 12 inch soil depth credit.
2. Fecal coliform not exceeding 1,000 CFU/100ml, or E. coli not exceeding 515 CFU/100ml for a 24 inch soil depth credit.
3. Fecal coliform not exceeding 200 CFU/100ml, or E. coli not exceeding 103 CFU/100ml for surface application.

1102.2.3 Nutrient reduction. The director or Board of Health shall establish nutrient reduction standards for pretreatment components where there is a significant risk of nutrient contamination to surface or ground water because of risk factors identified in the site review or other types of water quality assessments, or because of risks involved with the proximity to local, state, or federally recognized nutrient sensitive environments.

1102.2.3.1 Total nitrogen reduction. Where total nitrogen reduction is required, pretreatment components shall be capable of not less than a fifty percent reduction in the total nitrogen concentration based on average influent and effluent total nitrogen concentrations as demonstrated by NSF 245 or CAN/BNQ 3680-600. The actual reduction percentage for the pretreatment component shall be indicated.

1102.3.2.2 Other nutrients. The director or Board of Health shall develop standards for areas requiring greater reductions of other nutrients such as nitrogen or phosphorus.

1102.2.4 High strength waste. he director or Board of Health shall establish standards for the reduction of high strength waste or systems receiving sewage from sources producing or expected to produce sewage of a higher strength than typical residential sewage.

1102.2.5 Deemed to comply. The system shall be deemed to comply with the effluent quality standards provided that the system is operated and maintained in accordance with the permit approval documents. The system shall include one or more advanced treatment components for the removal of CBOD₅ and TSS before the wastewater is discharged to the receiving waters, common collector or ground or surface. A treatment component classified as "deemed to comply" shall be assumed to comply with the adopted standard without requiring effluent sampling during system operation.

SECTION 1103 EFFLUENT QUALITY FOR OFF-LOT DISCHARGE

1103.1 General. Advanced residential wastewater treatment systems shall be permitted to be used for off-lot discharges provided that circumstances do not allow for discharge of effluent to a soil based disposal field.

1103.2 Effluent quality standards. Advanced residential wastewater treatment systems shall comply with the performance based effluent quality standards in Sections 1103.2.1 through 1103.2.5, as applicable, in order to be considered for approval by the director for off-lot discharge.

1103.2.1 CBOD₅ and TSS. Treatment system effluent quality shall comply with both of the following 30 day average requirements for carbonaceous 5-day biochemical oxygen demand (CBOD₅) and total suspended solids (TSS).

1. CBOD₅ not exceeding 15 mg/l.
2. TSS not exceeding 18 mg/l.

1103.2.2 NH₃ ammonia. Treatment system effluent quality shall comply with both of the following 30 day average requirements for NH₃ ammonia.

1. NH₃ ammonia not exceeding 2 mg/l (summer).
2. NH₃ ammonia not exceeding 4 mg/l (winter).

1103.2.3 Dissolved oxygen. Treatment system effluent dissolved oxygen shall be not less than 6 mg/l.

1103.2.4 Fecal coliform and E. coli. Treatment system effluent fecal coliform shall not exceed 200 CFU/100ml.

1103.4 Effluent sample collection.

This section shall apply where periodic effluent sampling is required to determine whether an advanced residential wastewater treatment system is working properly, Collection of effluent shall be performed by a qualified service provider who is trained on the treatment technology. Samples shall be collected from the location and sample port approved by the system manufacturer. Effluent sample collection shall address all of the following guidelines:

1. Effluent shall not contain settleable solids above prescribed standards.
2. Color and odor shall be reduced to below discernable levels.
3. Effluent shall not contain floating debris, visible oil, grease, scum or sludge solids.
4. Fecal coliform bacteria concentration shall not exceed 200 CFU/100ml.
5. Any surface discharging system installed, repaired, renovated or replaced shall have a sample port downstream of and within a reasonable distance of the treatment tankage prior to discharge off-lot. For systems that are repaired or replaced and are connected to an existing effluent discharge line, one acceptable sampling port design shall be an inline cross fitting 4 inches (102 mm) in diameter with one branch extending deep enough to accept a sample bottle. For new construction, the sampling port design shall allow for collection of a free falling sample without the sample being tainted by existing flow in the port's sump.
6. A surface discharging system shall discharge to a roadside ditch, stream, pond, lake or other body of water with some method of disinfection.
7. Where samples are collected, they shall be analyzed in accordance with approved methods.

1103.2.5 Deemed to comply. The system shall be deemed to comply with the effluent quality standards provided that the system is operated and maintained in accordance with the permit approval documents. The system shall include one or more advanced treatment components for the removal of CBOD₅ and TSS before the wastewater is discharged to the receiving waters, common collector or ground surface. A treatment component shall be classified as deemed to comply because it complies with the adopted standard without requiring effluent sampling during system operation.

1103.3 Effluent discharges. Systems complying with NSF 245, Class R or C per NSF 350, Class I per NSF 40, or any department approved or accepted system shall discharge to any one of the following:

1. A receiving stream, river, lake or pond that provides greater than a 5:1 dilution of the effluent, based on the 7-day, 10-year low flow rate. A discharge within 10 feet of one of these receiving bodies of water shall be considered to be a discharge to the receiving body of water. Discharges to a lake or pond shall be limited to 2 discharges per surface acre of water. Where more than 2

discharges occur per individual surface acre of water, the total number of discharges to total surface acres of water shall not exceed a ratio of 2:1. Where discharges are not equally distributed around a lake or pond, the department or local authority shall be consulted to assure that nuisance conditions are not created.

2. A common collector, provided that the collector does not discharge within one mile upstream from a public water supply intake, public bathing beach, or to any public use area such as any area frequently used by the public.
3. The ground surface, where the discharge points of private sewage disposal systems with surface discharges do not exceed an average of one per acre and the effluent does not pond or create a nuisance condition.

Add new standard(s) follows:

NSF

NSF International
789 N. Dixboro Road
Ann Arbor MI 48105

NSF/ANSI 46 - 2016:

Evaluation of Components and Devices Used in Wastewater Treatment Systems

NSF/ANSI 245 - 2013:

Wastewater Treatment Systems - Nitrogen Reduction

CAN/BNQ Bureau De Normalisation Du Quebec CAN/BNQ 3680-600/2009 Onsite Residential Wastewater Treatment Technologies including Modification 1 dated March 16, 2017

Reason:

Currently, Chapter 11 only contains two very brief sections to cover a very complex topic. As currently written, no real guidance regarding Advanced Residential Treatment Systems is provided in Chapter 11. The language that I have proposed includes the details necessary to properly specify a treatment system for a residential application. The majority of the information included in this draft has been modeled after existing state codes that are currently being used. By adding additional details, this code will be valuable to regulators and will be more likely to be adopted.

Cost Impact

The code change proposal will increase the cost of construction .

As compared to the current version of the International Private Sewage Disposal Code, the proposed changes may result in increased costs, but the anticipated increased cost of advanced treatment technology may be offset by a reduction in the cost of the soil based disposal footprint for that particular technology. The current version of the code is limited and does not provide adequate guidance regarding the installation, maintenance and inspection of Advanced Residential Wastewater Treatment systems. In reality, most regulatory agencies responsible for onsite system installations have implemented their own sewage disposal codes, but these codes vary widely from state to state. There is significant value in publishing an International Private Sewage Disposal Code with detailed guidelines that could be adopted by these regulatory agencies in lieu of their existing codes. Harmonization of codes between regulatory agencies would allow manufacturers to focus their design efforts and not be restricted by provincial attitudes and practices. If a regulatory agency decides to adopt the International Private Sewage Disposal Code in place of their existing code, the actual cost impact would depend on the code being replaced. In its present form, the International Private Sewage Disposal Code only recognizes 19th and 20th Century onsite technology, and does not properly address the challenges of 21st Century site development.

The proposed changes will provide usable guidelines that regulatory agencies can use to assure that Advanced Residential Wastewater Treatment systems are installed, maintained and inspected in a manner that protects the public. The proposed changes are not intended to specify a particular treatment technology. There are many treatment technologies commercially available that meet the proposed guidelines, and these technologies vary in price depending on their complexity. Some simpler technologies may be available at pricing that is comparable to a conventional septic tank, while other more complex technologies could result in an additional \$5,000 to \$20,000. The more complex technologies are typically used in applications with very stringent effluent and/or monitoring requirements.

Analysis: A review of the standard proposed for inclusion in the code, CAN/BNQ 3680-600/2009 including Mod1 March 16, 2017, NSF 46-2016 and NSF 245-13, with regard to the ICC criteria for referenced standards (Section 3.6 of CP#28)

will be posted on the ICC website on or before April 2, 2018.

The referenced standard, NSF 350-2014, is currently referenced in other 2018 I-codes.

Internal ID: 384

PSD6-18

IPSDC: SECTION 1203 (New), 1203.1 (New), 1203.2 (New), 1203.3 (New), 1203.3.1 (New), 1203.3.2 (New), 1203.4 (New), 1203.5 (New), 1203.5.1 (New), 1203.5.2 (New), 1203.5.3 (New), 1203.6 (New), 1203.7 (New), 1203.8 (New), 1203.9 (New), 1203.10 (New), 1203.11 (New), 1203.12 (New), 1203.13 (New), 1203.14 (New), 1203.15 (New)

Proponent: Scott Hetrick, Norweco, Inc., representing Norweco, Inc. (shetrick@norweco.com)

2018 International Private Sewage Disposal Code

Add new text as follows:

SECTION 1203 SYSTEM MAINTENANCE

1203.1 General. An ongoing maintenance program shall be required for advanced residential wastewater treatment systems or any onsite system installation with a mechanical component. Periodic maintenance must be provided to the treatment system on an annual basis in the form of a renewable maintenance contract. The yearly maintenance visits shall be conducted by a service provider that has been trained by the system manufacturer or distributor.

1203.2 Installation. All components of advanced residential wastewater treatment systems shall be installed at the time of the original installation. If this is not possible, a solid end cap shall be securely placed over the end of the discharge line until the system can be completed to prevent the discharge of raw sewage to the ground surface.

1203.3 Accessibility for inspection and maintenance. Advanced residential wastewater treatment systems shall be equipped with ground-level access ports that are sized and located to facilitate the installation, removal, sampling, examination, maintenance, and servicing of components and compartments that require routine maintenance and inspection.

1203.3.1 Access port size and location. Ground-level access ports shall be of sufficient size and located so as to allow for the following:

1. Visual inspection and removal of all mechanical or electrical components.
2. Periodic cleaning or replacement of components and removal of residuals.
3. Visual inspection and sampling, including a means for collecting a representative effluent sample and determining the need for residuals removal.
4. Removal of collected residuals as required by the manufacturer in the operations and maintenance manual. If the operations and maintenance manual describes a means to determine the need to remove residuals from a chamber without ground-level access, then only the ability to install ground-level access shall be required. Systems without ground-level access to a chamber shall be equipped with a means to locate the opening to the chambers. This information shall be provided on or in a ground-level access opening.

1203.3.2 Access port protection. Access ports larger than 6 inches (152 mm) in diameter shall be protected against unauthorized intrusions. Acceptable protective measures include, but are not limited to:

1. A padlock.
2. A cover that can be removed only with specialized tools. Cover fasteners shall have tamper-resistant heads. Hex head, flat groove or Phillips head fasteners shall be prohibited.
3. A cover having a minimum net weight of 65 lb. (29.5 kg).

1203.4 Service. Advanced residential wastewater treatment systems shall require periodic maintenance to achieve performance consistent with demonstrated capabilities. Assured professional service is imperative to ensure system performance. A two-year initial service policy shall be furnished to the owner by the manufacturer or the authorized representative. The cost of the initial service policy shall be included in the original purchase price.

1203.5 Initial service policy. The private sewage disposal installation contractor, through the manufacturer or the distributor of the advanced residential wastewater treatment system, shall furnish a two-year initial service policy to the purchaser. This policy shall cover the requirements in Sections 1203.5.1 through 1203.5.3.

1203.5.1 Service calls. The policy shall include four inspection and service calls, not less than one every six months.

The call shall include inspection, adjustment and servicing of the mechanical and the applicable component parts to ensure proper function.

1203.5.2 Effluent quality inspection. The policy shall include an effluent quality inspection consisting of a visual check for color, turbidity, scum overflow, and an examination for odors.

1203.5.3 Homeowner reporting. The policy shall include immediate reporting to the owner about any improper operation that cannot be corrected at the time of the inspection or service call.

1203.6 Continuing service policy. Each manufacturer of a system shall make available for purchase by the owner, a continuing service policy with terms equal to the initial service policy.

1203.7 Standby parts. The local distributor shall stock standby mechanical and electrical component parts for use where the plant's mechanical or electrical components are required to be removed from the site for repairs.

1203.8 Component parts. The mechanical and electrical component parts shall be guaranteed against any defects in materials and workmanship as warranted.

1203.9 Service. Service shall be available within two working days following a request.

1203.10 Owner's manual. The manufacturer shall provide an owner's manual with each unit. The manual shall include the following information:

1. Model numbers
2. Functional description of unit, including a statement of minimum performance requirements as established by test
3. Design and flow diagrams
4. Warranty
5. Replacement policy and service policy
6. Installation instructions
7. Detailed operation and maintenance requirements including user responsibility, parts and service
8. Rated service flow in GPM (gallons per minute) or GPD (gallons per day)
9. Energy source and energy required for proper operation of the plant
10. Specification of models tested in accordance with NSF 40.

1203.11 Service label. A clearly visible, permanently attached label or plate giving instructions for obtaining service shall be placed at the audible and visual alarm.

1203.12 Responsibility of property owner. The property owner shall be responsible for maintaining and operating the system in accordance with this code and the manufacturer's specifications.

1203.13 Maintenance. If a routine service call indicates an electrical, mechanical or performance failure or malfunction or if routine laboratory test results indicate improper treatment, the property owner shall immediately take action to bring the advanced residential wastewater treatment system into compliance with this section.

1203.14 Non-residential use. Advanced residential wastewater treatment systems certified to comply with Class I requirements of NSF 40 by an ANSI accredited third-party certification agency shall be considered for use to serve a non-residential property, provided that all of the following are met:

1. Total daily flows from the wastewater source into the plant are at least 75% of the rated hydraulic capacity and do not exceed the rated hydraulic capacity of the plant.
2. Wastewater influent does not exceed the manufacturer's design specifications for BOD₅ loading as established by the ANSI accredited third-party certification agency to determine compliance with NSF 40 during testing of the system.

1203.15 Certification compliance. Private sewage disposal installation contractors or building owners who maintain or service wastewater treatment systems that have been certified to the NSF standards shall be required to maintain the integrity of the seal of the ANSI accredited third-party certification agency that has certified the

compliance with the appropriate standard. Only component parts approved by the manufacturer for use in an individual system shall be used. No design changes or component part changes shall be made that will void compliance with the appropriate standard. Any person who voids the compliance with the appropriate standard shall be responsible for repairing the system so it can bear the seal of the ANSI accredited third-party certification agency that has certified compliance or the person shall replace the plant with an approved residential wastewater treatment system.

Reason:

Currently, Chapter 12 does not provide much detail regarding the actual inspection of a private sewage disposal system. In addition, maintenance and service is typically performed in conjunction with routine service inspections. It makes sense to include language in this chapter that provides some direction for the maintenance and service of private sewage treatment systems. The majority of the information included in this draft has been modeled after existing state codes that are currently being used. By adding additional details, this code will be valuable to regulators and will be more likely to be adopted.

Cost Impact

The code change proposal will increase the cost of construction .

As compared to the current version of the International Private Sewage Disposal Code, the proposed changes may result in increased costs, but the anticipated increased cost of advanced treatment technology may be offset by a reduction in the cost of the soil based disposal footprint for that particular technology. The current version of the code is limited and does not provide adequate guidance regarding the installation, maintenance and inspection of Advanced Residential Wastewater Treatment systems. In reality, most regulatory agencies responsible for onsite system installations have implemented their own sewage disposal codes, but these codes vary widely from state to state. There is significant value in publishing an International Private Sewage Disposal Code with detailed guidelines that could be adopted by these regulatory agencies in lieu of their existing codes. Harmonization of codes between regulatory agencies would allow manufacturers to focus their design efforts and not be restricted by provincial attitudes and practices. If a regulatory agency decides to adopt the International Private Sewage Disposal Code in place of their existing code, the actual cost impact would depend on the code being replaced. In its present form, the International Private Sewage Disposal Code only recognizes 19th and 20th Century onsite technology, and does not properly address the challenges of 21st Century site development.

The proposed changes will provide usable guidelines that regulatory agencies can use to assure that Advanced Residential Wastewater Treatment systems are installed, maintained and inspected in a manner that protects the public. The proposed changes are not intended to specify a particular treatment technology. There are many treatment technologies commercially available that meet the proposed guidelines, and these technologies vary in price depending on their complexity. Some simpler technologies may be available at pricing that is comparable to a conventional septic tank, while other more complex technologies could result in an additional \$5,000 to \$20,000. The more complex technologies are typically used in applications with very stringent effluent and/or monitoring requirements.

Internal ID: 418

**2018 GROUP A – PROPOSED CHANGES TO THE
INTERNATIONAL PROPERTY MAINTENANCE / ZONING
CODE**

PROPERTY MAINTENANCE / ZONING CODE COMMITTEE

Richard G. Lambert, CBO, Chair
Director of Code Enforcement
City of Saco
Saco, ME

Teresa E. Gerber, CPMO, Vice Chair
Building Inspector III, Property Maintenance Div.
Chesterfield County, Department of Building
Inspections
Chesterfield, VA

Ted Bush, Jr., CBO
Plans Examiner
The City of Helena Montana
Helena, MT

John Christophe
Manager
City of Austin Code Department
Austin, TX

Jimmie Deer
Building Official
City of Fort Smith
Fort Smith, AR

Kyley Flynn
Building Inspector
SAFEbuilt
Firestone, CO

Glenn Holt
Building Official
Marple Township
Broomall, PA

Lucas Pump
Building Inspector/Code Enforcement
City of Cedar Rapids
Cedar Rapids, IA

M. Hannah Leslie Reig, RA
Planner II
City of Florence (Planning, Research &
Development)
Florence, SC

Laura Rouse-Devore, CCEO
Senior Property Maintenance Inspector
City of Evanston, Illinois
Evanston, IL

Emily A. Ryan
President
Mt. Hermon Planning & Permitting Corp.
Chicago, IL

Fred T. Stokley, Jr., BI
Building Inspector Supervisor/Residential Plan
Reviewer
Lexington Fayette Urban County Government
Lexington, KY

Staff Secretariat:
Edward Wirtschoreck, RA
Manager, Standards
International Code Council
Central Regional Office
County Club Hills, IL

TENTATIVE ORDER OF DISCUSSION 2018 PROPOSED CHANGES TO THE INTERNATIONAL PROPERTY MAINTENANCE CODE

The following is the tentative order in which the proposed changes to the code will be discussed at the public hearings. Proposed changes which impact the same subject have been grouped to permit consideration in consecutive changes.

Proposed change numbers that are indented are those which are being heard out of numerical order. Indentation does not necessarily indicate that one change is related to another. Proposed changes may be grouped for purposes of discussion at the hearing at the discretion of the chair. Note that some PM code change proposals may not be included on this list, as they are being heard by another committee.

G5-18 Part II

PM1-18

PM2-18

PM3-18

PM4-18

PM5-18

PM6-18

PM7-18

PM8-18 Part I

PM9-18

G130-18 Part II

PM10-18

PM11-18

PM1-18

IPMC: SECTION 202, 202 (New)

Proponent: Ronald George, Plumb-Tech Design & Consulting Services LLC, representing Self (Ron@Plumb-TechLLC.com)

2018 International Property Maintenance Code

SECTION 202 GENERAL DEFINITIONS

Add new definition as follows:

HAZARD. Any condition that could cause harm or a serious life threatening injury or death at any time, including but not limited to a trip hazard, slip hazard or scald hazard. An exposure to danger or risk that can be harmful.

Reason:

The word hazard has been included in a code change proposal. This definition will assist inspectors with enforcing safe conditions related to what a hazard is.

Cost Impact

The code change proposal will not increase or decrease the cost of construction .

This is just adding a definition for the term "Hazard"

Internal ID: 1851

PM2-18

IPMC: 202, 202 (New)

Proponent: Ronald George, Plumb-Tech Design & Consulting Services LLC, representing Self (Ron@Plumb-TechLLC.com)

2018 International Property Maintenance Code

Add new definition as follows:

SECTION 202 GENERAL DEFINITIONS

SAFE. Free of hazards or any condition that could cause harm or a serious life threatening injury or death at any time, including but not limited to trip hazards, slip hazards or scald hazards. Protected from or not exposed to danger or risk; not likely to be harmed.

Reason:

The term "safe" is used in the property maintenance code in many locations and there is no definition. This definition will assist inspectors with enforcing safe conditions.

Cost Impact

The code change proposal will not increase or decrease the cost of construction .

A safe condition is already required, this is just defining "Safe".

Internal ID: 1802

PM3-18

IPMC: SECTION 202, 202 (New), 302.4

Proponent: Francis McAndrew, representing New York State Department of State, Division of Building Standards and Codes (francis.mcandrew@dos.ny.gov)

2018 International Property Maintenance Code

SECTION 202 GENERAL DEFINITIONS

Add new definition as follows:

WEEDS. Uncultivated vegetation such as grasses, brush, briars, and annual plants, excluding trees and cultivated vegetation, such as shrubs, flowers, gardens, and vegetation used for agricultural purposes.

Revise as follows:

302.4 Weeds. ~~Premises and exterior property~~ Except as provided for in statute, local law, ordinance, or other regulations, all developed areas of a premises that are intended to be used by building occupants or the public shall be maintained free from weeds or plant growth in excess of [JURISDICTION TO INSERT HEIGHT IN INCHES]. Noxious weeds shall be prohibited. Weeds shall be defined as all grasses, annual plants and vegetation, other than trees or shrubs provided; however, this term shall not include cultivated flowers and gardens. Upon failure of the *owner* or agent having charge of a property to cut and destroy weeds after service of a notice of violation, they shall be subject to prosecution in accordance with Section 106.3 and as prescribed by the authority having jurisdiction. Upon failure to comply with the notice of violation, any duly authorized employee of the jurisdiction or contractor hired by the jurisdiction shall be authorized to enter upon the property in violation and cut and destroy the weeds growing thereon, and the costs of such removal shall be paid by the *owner* or agent responsible for the property.

Reason:

This code change proposal is intended to correct the following shortcomings:

1. It removes the definition of “weeds” from this code section and places it in Section 202 with the remainder of the definitions.
2. The definition of “weeds” is modified to make a distinction between cultivated and uncultivated vegetation, and vegetation used for agricultural purposes.
3. It provides an avenue for jurisdictions to more readily modify the maintained area of a premises and weed height requirement (“except as provided for in statute, local law, ordinance or other regulation”).
4. Requiring the entire premises to be maintained weed free is unrealistic and overly burdensome for undeveloped parcels, parcels that are only partially developed, and rural areas. This proposal requires only developed areas of a premises that are intended to be used by building occupants or the public to be maintained weed free. Allowing taller weed growth and plant diversity in undeveloped and undisturbed areas of a premises maintains the site's natural pre-developed conditions thereby promoting groundwater recharge, which is required by many (if not most) stormwater management regulations. Allowing taller weed growth and plant diversity also ensures habitat for wildlife.
5. This approach is more practical for undeveloped parcels, parcels that are only partially developed, and rural areas. Vacant land is currently required to be “maintained in a clean, safe, secure and sanitary condition as provided herein so as not to cause a blighting problem or adversely affect the public health or safety”, pursuant to IPMC Section 301.3.

Cost Impact

The code change proposal will decrease the cost of construction .

This code change will reduce the maintenance burden by not requiring the entire premises to be maintained weed free, but instead only the developed portions of a premises used by building occupants or the public.

Internal ID: 1348

PM4-18

IPMC: 302.8

Proponent: Francis McAndrew, representing New York State Department of State, Division of Building Standards and Codes (francis.mcandrew@dos.ny.gov)

2018 International Property Maintenance Code

Revise as follows:

302.8 Motor vehicles. Except as provided for in statute, local law, ordinance, or other regulations, not more than one inoperative or unlicensed motor ~~vehicles~~~~vehicle~~ shall ~~not~~ be parked, kept, or stored on any *premises*, and vehicles shall not at any time be in a state of major disassembly, ~~disrepair~~, or in the process of being stripped or dismantled. Painting of vehicles is prohibited unless conducted inside an *approved* spray booth.

Exception: A vehicle of any type is permitted to undergo major overhaul, including body work, provided that such work is performed inside a structure or similarly enclosed area designed and *approved* for such purposes.

Reason:

The existing code section uses the phrase: "Except as provided for in other regulations" in an attempt to provide an avenue for an adopting jurisdiction to modify the number of vehicles stored on a property. Unfortunately, the word "regulations" may have different meanings in different jurisdictions across the country, thereby requiring modification of this code section by the adopting jurisdiction. The proposed code change generalizes the word "regulations", and inserts the words "statute", "local law", and "ordinance" to accommodate the variations of rule making across the country, thereby making this code section more of a true model code.

Notwithstanding the exception, the current code prohibits inoperative or unlicensed motor vehicles from being stored on a premises. This requirement is overly burdensome because not all home owners have access to a "structure or similarly enclosed area" (garage) to repair a motor vehicle as required by the exception. Because not everyone has access to a garage, this code section infringes on the rights and abilities of homeowners from being able to perform a minor repair on their "motor vehicle", thereby rendering it operable. Examples include replacing a starter, brakes, or belts, all of which are generally not considered a "major overhaul" as provided for in the exception. Furthermore, a "motor vehicle" could be something as simple as a motor scooter, all-terrain vehicle (ATV/four wheeler), recreational vehicle, or farm equipment, since the term "motor vehicle" has different legal definitions across the country. The proposed code change alleviates this burden by allowing not more than one vehicle, but maintains that this requirement can be overruled by a jurisdiction via statute, local law, ordinance, or other regulations. The proposed code change removes the word "disrepair" to ensure that a motor vehicle stored on a premises can be repaired, but also ensures that vehicles are not in a major state of disassembly or stripped, thereby preventing a junk yard appearance.

Cost Impact

The code change proposal will not increase or decrease the cost of construction .

The proposed code modification does not alter a standard for construction, but instead clarifies the intent of the code as it relates to the storage of motor vehicles. Consequently, the proposed code change will neither increase nor decrease the cost of construction.

Internal ID: 1238

PM5-18

IPMC: 304.1.1, 305.1.1, 306.1.1

Proponent: Michael Fillion, representing Existing Buildings Subcommittee, National Council of Structural Engineers Association (mrf.structure@verizon.net)

2018 International Property Maintenance Code

Revise as follows:

304.1.1 Unsafe conditions. ~~The following Unsafe conditions shall be determined as unsafe and shall be repaired or replaced to comply with the International Building Code or in compliance with the International Existing Building Code as required for existing buildings: Code.~~

- ~~1. The nominal strength of any structural member is exceeded by nominal loads, the load effects or the required strength.~~
- ~~2. The anchorage of the floor or roof to walls or columns, and of walls and columns to foundations is not capable of resisting all nominal loads or load effects.~~
- ~~3. Structures or components thereof that have reached their limit state.~~
- ~~4. Siding and masonry joints including joints between the building envelope and the perimeter of windows, doors and skylights are not maintained, weather resistant or water tight.~~
- ~~5. Structural members that have evidence of *deterioration* or that are not capable of safely supporting all nominal loads and load effects.~~
- ~~6. Foundation systems that are not firmly supported by footings, are not plumb and free from open cracks and breaks, are not properly *anchored* or are not capable of supporting all nominal loads and resisting all load effects.~~
- ~~7. Exterior walls that are not anchored to supporting and supported elements or are not plumb and free of holes, cracks or breaks and loose or rotting materials, are not properly *anchored* or are not capable of supporting all nominal loads and resisting all load effects.~~
- ~~8. Roofing or roofing components that have defects that admit rain, roof surfaces with inadequate drainage, or any portion of the roof framing that is not in good repair with signs of *deterioration*, fatigue or without proper anchorage and incapable of supporting all nominal loads and resisting all load effects.~~
- ~~9. Flooring and flooring components with defects that affect serviceability or flooring components that show signs of *deterioration* or fatigue, are not properly anchored or are incapable of supporting all nominal loads and resisting all load effects.~~
- ~~10. Veneer, cornices, belt courses, corbels, trim, wall facings and similar decorative features not properly anchored or that are anchored with connections not capable of supporting all nominal loads and resisting all load effects.~~
- ~~11. Overhang extensions or projections including, but not limited to, trash chutes, canopies, marquees, signs, awnings, fire escapes, standpipes and exhaust ducts not properly *anchored* or that are anchored with connections not capable of supporting all nominal loads and resisting all load effects.~~
- ~~12. Exterior stairs, decks, porches, balconies and all similar appurtenances attached thereto, including *guards* and handrails, are not structurally sound, not properly *anchored* or that are *anchored* with connections not capable of supporting all nominal loads and resisting all load effects.~~
- ~~13. Chimneys, cooling towers, smokestacks and similar appurtenances not structurally sound or not properly *anchored*, or that are anchored with connections not capable of supporting all nominal loads and resisting all load effects.~~

Exceptions:

1. Where substantiated otherwise by an *approved* method.
2. Demolition of unsafe conditions shall be permitted where *approved* by the *code official*.

305.1.1 Unsafe conditions. ~~The following Unsafe conditions shall be determined as unsafe and shall be repaired or replaced to comply in compliance with the International Building Code or the International Existing Building Code as required for existing buildings:~~

- ~~1.The nominal strength of any structural member is exceeded by nominal loads, the load effects or the required strength.~~
- ~~2.The anchorage of the floor or roof to walls or columns, and of walls and columns to foundations is not capable of resisting all nominal loads or load effects.~~
- ~~3.Structures or components thereof that have reached their limit state.~~
- ~~4.Structural members are incapable of supporting nominal loads and load effects.~~
- ~~5.Stairs, landings, balconies and all similar walking surfaces, including *guards* and handrails, are not structurally sound, not properly *anchored* or are *anchored* with connections not capable of supporting all nominal loads and resisting all load effects.~~
- 6.Foundation systems that are not firmly supported by footings are not plumb and free from open cracks and breaks, are not properly *anchored* or are not capable of supporting all nominal loads and resisting all load effects.

Code.

1.

2.

3.

4.

5.

6.

Exceptions:

1. Where substantiated otherwise by an *approved* method.
2. Demolition of unsafe conditions shall be permitted where *approved* by the *code official*.

306.1.1 Unsafe conditions. Where any of the following conditions cause the component or system to be beyond its limit state, the component or system shall be determined as unsafe and Unsafe components and systems shall be repaired or replaced to comply with the International Building Code or in compliance with the International Existing Building Code. as required for existing buildings:

1. ~~Soils that have been subjected to any of the following conditions:~~
 - 1.1. ~~Collapse of footing or foundation system.~~
 - 1.2. ~~Damage to footing, foundation, concrete or other structural element due to soil expansion.~~
 - 1.3. ~~Adverse effects to the design strength of footing, foundation, concrete or other structural element due to a chemical reaction from the soil.~~
 - 1.4. ~~Inadequate soil as determined by a geotechnical investigation.~~
 - 1.5. ~~Where the allowable bearing capacity of the soil is in doubt.~~
 - 1.6. ~~Adverse effects to the footing, foundation, concrete or other structural element due to the ground water table.~~
2. ~~Concrete that has been subjected to any of the following conditions:~~
 - 2.1. ~~*Deterioration.*~~
 - 2.2. ~~*Ultimate deformation.*~~
 - 2.3. ~~Fractures.~~
 - 2.4. ~~Fissures.~~
 - 2.5. ~~Spalling.~~
 - 2.6. ~~Exposed reinforcement.~~
 - 2.7. ~~*Detached, dislodged or failing connections.*~~
3. ~~Aluminum that has been subjected to any of the following conditions:~~
 - 3.1. ~~*Deterioration.*~~
 - 3.2. ~~Corrosion.~~

- 3.3. ~~Elastic deformation.~~
- 3.4. ~~Ultimate deformation.~~
- 3.5. ~~Stress or strain cracks.~~
- 3.6. ~~Joint fatigue.~~
- 3.7. ~~Detached, dislodged or failing connections.~~
- 4. ~~Masonry that has been subjected to any of the following conditions:~~
 - 4.1. ~~Deterioration.~~
 - 4.2. ~~Ultimate deformation.~~
 - 4.3. ~~Fractures in masonry or mortar joints.~~
 - 4.4. ~~Fissures in masonry or mortar joints.~~
 - 4.5. ~~Spalling.~~
 - 4.6. ~~Exposed reinforcement.~~
 - 4.7. ~~Detached, dislodged or failing connections.~~
- 5. ~~Steel that has been subjected to any of the following conditions:~~
 - 5.1. ~~Deterioration.~~
 - 5.2. ~~Elastic deformation.~~
 - 5.3. ~~Ultimate deformation.~~
 - 5.4. ~~Metal fatigue.~~
 - 5.5. ~~Detached, dislodged or failing connections.~~
- 6. ~~Wood that has been subjected to any of the following conditions:~~
 - 6.1. ~~Ultimate deformation.~~
 - 6.2. ~~Deterioration.~~
 - 6.3. ~~Damage from insects, rodents and other vermin.~~
 - 6.4. ~~Fire damage beyond charring.~~
 - 6.5. ~~Significant splits and checks.~~
 - 6.6. ~~Horizontal shear cracks.~~
 - 6.7. ~~Vertical shear cracks.~~
 - 6.8. ~~Inadequate support.~~
 - 6.9. ~~Detached, dislodged or failing connections.~~
 - 6.10. ~~Excessive cutting and notching.~~

Exceptions:

- 1. Where substantiated otherwise by an *approved* method.
- 2. Demolition of unsafe conditions shall be permitted where *approved* by the *code official*.

Reason:

This proposal corrects errors and removes duplication in the IPMC of provisions already covered more appropriately in the IBC and IEBC.

Unsafe conditions are rare and represent extreme situations. As such, they are outside the general scope (see Section 101.2) and intent (101.3) of the IPMC. Rather, they are more properly addressed by the IBC and IEBC, which already define unsafe conditions to include "inadequate maintenance" and provide remedial administrative procedures (IBC Section 116, IEBC Section 115). In fact, the IPMC relies on the IEBC definitions of unsafe and dangerous, as it does not provide its own definitions in Chapter 2.

Consider the many references in these three sections to structural elements and their resistance to "nominal loads" and "all load effects." Nominal loads include full Wind and Earthquake loads. Applying these provisions as currently written would cause every building more than about 20 years old to be labeled dangerous and unsafe even in the absence of deterioration or damage. Further, by referencing structural loads and capacities, simple implementation of

the IPMC would require regular assessment by a structural engineer, which is certainly beyond the code's intent.

Consider the many references to structural "soundness." This term is undefined and unenforceable. Provisions requiring structurally sound conditions were removed from the IBC and IEBC for this reason over the last several code cycles.

Consider the several references to a component's "limit state." These references are inappropriate because, as defined in the IBC, there are multiple possible limit states. Merely exceeding a serviceability limit state (especially as contemplated by Section 306.1.1) almost never makes a building or component unsafe.

Consider the many references to deterioration. Deterioration is indeed a sign that maintenance is needed, but it is not a reason to label a building or component unsafe. Similarly, corrosion, elastic deformation, sapling, and cracks (especially as listed in Section 306.1.1) are often normal and are not of themselves reason to label a building or component unsafe. (The IEBC definition of unsafe includes "inadequate maintenance," meaning "not enough to maintain health, safety, and welfare," not merely non-compliant or imperfect maintenance.)

Despite the deletion of these long lists, the proposal results in no loss of substance. As noted, unsafe conditions are already defined and addressed in the IEBC. More specifically, each of the items proposed for deletion is already covered elsewhere in the IPMC. Considering the list in Section 304.1.1:

- Items 1, 2, 3, 5, 6, and 7 address structural elements and thus are already covered by the IEBC

and IBC definition of dangerous.

- Item 4 is addressed in Section 304.6.

- Item 8 is addressed in Section 304.7.

- Item 9 does not even belong in Section 304 but is addressed in Section 305.4

- Item 10 is addressed in Section 304.8.

- Item 11 is addressed in Section 304.9.

- Item 12 is addressed in Section 304.10.

- Item 13 is addressed in Section 304.1.

Considering the list in Section 305.1.1: Items 1 through 6 address structural elements and thus are already covered by the IBC and IEBC definition of dangerous. Item 5 is additionally addressed by Section 305.4.

Considering the list in Section 306.1.1: Items 1 through 6 address components in terms of their structural materials and properties and thus are already covered by the IBC and IEBC definition of dangerous.

Finally, in addition to removing the inappropriate lists, the proposal requires compliance only with the IEBC, not the IBC, because the IPMC by definition relates to existing buildings, and the IBC no longer has existing building provisions for repair or removal of unsafe conditions.

If approved, a coordinated proposal will be made in Group B to address further duplication and overlap in IPMC Section 108.

Cost Impact

The code change proposal will not increase or decrease the cost of construction .

The proposal merely removes duplicate provisions already found in the other applicable codes.

Internal ID: 2278

PM6-18

IPMC: 305.3

Proponent: Sean Glasscock, representing City of Claremont New Hampshire, Building Inspector and Deputy Health Officer (sglasscock@claremontnh.com)

2018 International Property Maintenance Code

Revise as follows:

305.3 Interior surfaces. Interior surfaces, including walls, ceilings, floors, windows and doors, shall be maintained in good, clean and sanitary condition. Peeling, chipping, flaking or abraded paint shall be repaired, removed or covered. Cracked or loose plaster, decayed wood, water damage and staining, and other defective surface conditions shall be corrected.

Reason:

The current version of the Interior Surfaces section of the International Property Maintenance code gives the reader the implication that it is "including windows and doors" and not speaking to the other interior surfaces. Adding additional language clarifies the requirement that all interior surfaces shall be maintained in good, clean and sanitary condition. Citing section 305.3 for other than windows and doors in its current state could be challenged as incorrect interpretation of the code. It must be changed to be clarified.

Cost Impact

The code change proposal will not increase or decrease the cost of construction .

This proposal is a clarification and will not effect the cost of construction.

Internal ID: 1445

PM7-18

IPMC: 305.4

Proponent: Sean Glasscock, City of Claremont NH, representing City of Claremont New Hampshire, Building Inspector and Deputy Health Officer (sglasscock@claremontnh.com)

2018 International Property Maintenance Code

Revise as follows:

305.4 ~~Stairs~~ Walking surfaces and walking surfaces flooring. Every ~~stair~~walking surface, ramp~~including stairs,~~ landing~~ramps, balcony~~landings, porch, deck or balconies, porches, decks, and other walking surface~~surfaces~~ shall be maintained in sound condition and good repair. All interior flooring and floor covering including laminate, tile, carpet, hardwood and/or manufactured composite flooring shall be maintained in good repair.

Reason:

The current version of the International Property Maintenance Code lacks clear and concise language about the condition of interior flooring which is a major concern for the safety of residents and visitors. Flooring condition is often cited during a property maintenance inspection as being in poor condition. The current language does not adequately address the issue and may become an enforcement problem if challenged.

Cost Impact

The code change proposal will not increase or decrease the cost of construction .

Cost impact will be negligible because flooring condition is already cited, this code change just strengthens the language.

Internal ID: 1410

PM8-18 Part I

IPMC: SECTION 310 (New), 310.1 (New), 310.2 (New), 310.3 (New), 310.4 (New), ordinal

Proponent: Jonathan Roberts, UL LLC, representing UL LLC (jonathan.roberts@ul.com)

THIS IS A 2 PART CODE CHANGE. PART I WILL BE HEARD BY THE IPMC COMMITTEE. PART II WILL BE HEARD BY THE IFC CODE COMMITTEE. SEE THE TENTATIVE HEARING ORDER FOR THESE COMMITTEES.

2018 International Property Maintenance Code

Add new text as follows:

SECTION 310 STORM SHELTERS

310.1 Inspection and maintenance. Storm shelters required by Section 423 of the International Building Code, Section 1106 of the International Existing Building Code, or otherwise legally required in a jurisdiction shall be inspected and maintained in accordance with this section.

310.2 Door function. Storm shelter doors, and door hardware, shall be maintained to ensure proper door operation as required by ICC 500.

310.3 Damage or missing components. Storm shelters shall be maintained in accordance with ICC 500 so that walls and roofs are intact and undamaged. Any damage to the storm shelter or its impact-protective systems shall be repaired or replaced in accordance with ICC 500. Missing equipment or components shall be replaced.

310.4 Replacement components. Where it is necessary to replace impact-protective systems, including certified doors, shutters, windows or their frames, hardware, and closing mechanisms, replacements shall comply with applicable ICC 500 requirements.

Add new standard(s) follows:

ICC

International Code Council
500 New Jersey Avenue, NW 6th
Floor
Washington DC 20001
US

ICC 500-2014:

ICC/NSSA Standard for the Design and Construction of Storm Shelters

Analysis: The referenced standard, ICC 500-2014, is currently referenced in other 2018 I-codes.

Internal ID: 1314

PM8-18 Part II

IFC: 301.1, SECTION 320 (New), 320.1 (New), 320.2 (New), 320.3 (New), 320.4 (New), ordinal

Proponent: Jonathan Roberts, UL LLC, representing UL LLC (jonathan.roberts@ul.com)

2018 International Fire Code

Revise as follows:

301.1 Scope. The provisions of this chapter shall govern the occupancy and maintenance of all structures and premises for precautions against fire and the spread of fire and general requirements of fire and life safety.

Add new text as follows:

SECTION 320 STORM SHELTERS

320.1 Inspection and maintenance. Storm shelters required by Section 423 of the International Building Code, Section 1106 of the International Existing Building Code, or otherwise legally required in a jurisdiction shall be inspected and maintained in accordance with this section.

320.2 Door function. Storm shelter doors and door hardware shall be maintained to ensure proper door operation as required by ICC 500.

320.3 Damage or missing components. Storm shelters shall be maintained in accordance with ICC 500 so that walls and roofs are intact and undamaged. Any damage to the storm shelter or its impact-protective systems shall be repaired or replaced in accordance with ICC 500. Missing equipment or components shall be replaced.

320.4 Replacement components. Where it is necessary to replace impact-protective systems, including certified doors, shutters, windows or their frames, hardware, and closing mechanisms, replacements shall comply with applicable ICC 500 requirements.

Add new standard(s) follows:

ICC

International Code Council, Inc.
500 New Jersey Avenue, NW 6th
Floor
Washington DC 20001
US

ICC 500-2014:

ICC/NSSA Standard for the Design and Construction of Storm Shelters

Reason:

Storm shelters are relied upon to protect citizens in communities prone to tornadoes, hurricanes, or other similar extreme weather events. It is important to make sure that the shelters, in particular the impact protection systems, doors, and latching components are maintained in an operable condition so they will provide shelter when needed. This proposal includes basic safety requirements for maintaining desired protection.

Cost Impact

The code change proposal will not increase or decrease the cost of construction .

This change would not result in any increase in the initial construction cost, but could be a minimal increase for the inspection, maintenance, and repairs, especially if the storm shelter is damaged by an inclement weather event.

Analysis: The referenced standard, ICC 500-2014, is currently referenced in other 2018 I-codes.

Internal ID: 1308

PM9-18

IPMC: 404.4, 404.4.1, 404.5, TABLE 404.5

Proponent: Gerard Hathaway, NYS Dept. of State, Div. of Building Standards and Codes, representing New York State Department of State, Division of Building Standards and Codes (gerard.hathaway@dos.state.ny.us)

2018 International Property Maintenance Code

Revise as follows:

404.4 ~~Bedroom~~ Habitable room and living room-bedroom requirements. Every habitable room and bedroom ~~and living room~~ shall comply with the requirements of Sections 404.4.1 through 404.4.5.

404.4.1 Room area. Every ~~living room~~ shall contain not less than ~~120 square feet (11.2 m²)~~ and every bedroom habitable room shall contain not less than 70 square feet (6.5 m²) and every bedroom occupied by more than one person shall contain not less than 50 square feet (4.6 m²) of floor area for each occupant thereof.

404.5 Overcrowding. Dwelling units shall not be occupied by more occupants than permitted by the minimum area requirements of Table 404.5.

**TABLE 404.5
MINIMUM AREA REQUIREMENTS**

SPACE	MINIMUM AREA IN SQUARE FEET		
	1-2 occupants	3-5 occupants	6 or more occupants
Living room ^{a, b}	120-70	120	150
Dining room ^{a, b}	No requirement	80	100
Bedrooms	Shall comply with Section 404.4.1		

For SI: 1 square foot = 0.0929 m².

- See Section 404.5.2 for combined living room/dining room spaces.
- See Section 404.5.1 for limitations on determining the minimum occupancy area for sleeping purposes.

Reason:

The purpose of this code change is to coordinate the minimum room area requirements found in the International Property Maintenance Code (IPMC) with those found in the International Residential Code (IRC) and the International Building Code (IBC). We have received technical support questions on this subject in New York State, and nationally it has been discussed in industry related online chat rooms.

IPMC 404.4.1 requires that every living room contain not less than 120 square feet (11.2 m²) and every bedroom contain not less than 70 square feet (6.5 m²). The IBC has similar language which is somewhat compatible with the IPMC, requiring that every dwelling unit shall have not less than one room (not specifically a living room) that shall have not less than 120 square feet (11.2 m²) of net floor area, and that other habitable rooms (not only but including bedrooms) shall have a net floor area of not less than 70 square feet (6.5 m²). However, IRC R304.1 simply requires that habitable rooms (including living rooms, bedrooms, etc.) shall have a floor area of not less than 70 square feet (6.5 m²).

Possible scenarios: A dwelling unit could be constructed under the IRC or IBC with a 70 square foot living room as allowed by both the IRC and IBC, receive a Certificate of Occupancy, and they would not be in compliance with the 2018 IPMC, which requires a minimum 120 square foot living room.

The proposed changes to IPMC 404.4 and 404.4.1 are meant to use language (the term "habitable rooms") which is compatible with both the IRC and IBC for consistency. Also, to allow small dwellings to have the minimum 70 square foot living rooms as intended by both the IRC and IBC.

This code change proposal also includes a change in IPMC 404.5 Overcrowding, specifically Table 404.5 Minimum Area Requirements. The "Living Room"/"1-2 occupants" cell of the table has been changed to delete the minimum 120 square foot requirement, and allow a minimum 70 square foot Living Room for 1-2 occupants in small dwellings constructed under either the IRC or IBC.

This change continues the effort to allow smaller dwellings built under the IRC and IBC to be compatible with the IPMC

once they are completed. Code change proposal RB106-13 (R304.1, R304.2), approved for the 2015 IRC, removed the requirement that every dwelling unit have at least one room not less than 120 square feet. One of the prime reasons given for that code change proposal was to allow small dwellings to be built under the IRC.

Cost Impact

The code change proposal will decrease the cost of construction .

Allowing small homes to be built, without forcing them to provide a 120 square foot living room, will decrease cost.

Internal ID: 1363

PM10-18

IPMC: 602.2

Proponent: Kelly Kirk, City of Norfolk, representing City of Norfolk; Christina Jackson, City of Norfolk, representing City of Norfolk

2018 International Property Maintenance Code

Revise as follows:

602.2 Residential occupancies. Dwellings shall be provided with heating facilities capable of maintaining a room temperature of 68°F (20°C) in all habitable rooms, *bathrooms* and *toilet rooms* based on the winter outdoor design temperature for the locality indicated in Appendix D of the International Plumbing Code. Cooking appliances shall not be used, nor shall portable unvented fuel-burning space heaters be used, as a means to provide required heating. Additionally, the installation of one or more portable space heaters shall not be used to achieve compliance with this section.

Exception: In areas where the average monthly temperature is above 30°F (-1°C), a minimum temperature of 65°F (18°C) shall be maintained.

Reason:

This proposed change is submitted with the intent to bring the IPMC 602.2 verbiage in line with the current IRC R303.9 verbiage so that these I-Codes cohesively reflect the intent of the ICC as currently written in the IRC R303.9.

Bibliography:

2015 IPMC, Section 602.2 - Heating Facilities, Residential Occupancies; ICC; Fourth Printing, December 2015; Page 2.

2015 IRC, Section R303.9 - Required Heating; ICC; Second Printing, January 2016; Page 56.

Cost Impact

The code change proposal will not increase or decrease the cost of construction .

This proposal merely clarifies existing code requirements by aligning the requirements of IPMC with the IRC.

Internal ID: 2119

PM11-18

IPMC: 703.8 (New)

Proponent: Sean Glasscock, representing City of Claremont New Hampshire, Building Inspector and Deputy Health Officer (sglasscock@claremontnh.com)

2018 International Property Maintenance Code

Add new text as follows:

703.8 Flammable insulation material. All paper faced insulation and foam insulation shall be protected as required elsewhere in the International Codes. Paper faced insulation and foam insulation shall not be left exposed to the interior of the building.

Exception:Where approved documentation is submitted to the building official showing the material meets the requirements for exposed interior finishes elsewhere in the International Codes.

Reason:

The current version of the International Property Maintenance Code does not contain clear and concise language regarding the condition of exposed flammable insulation material. Commonly found during inspections is paper faced insulation or foam plastic insulation exposed to the interior of the building which creates a significant fire hazard. Often, it should not have been installed and left in the exposed condition but rather appropriately covered according to the manufacturer's installation instructions that are printed on the material. This code change will simply clarify that requirement and allow for more effective enforcement.

Cost Impact

The code change proposal will not increase or decrease the cost of construction .

This is already required in new construction. The concern is older existing construction. There are multiple cost effective ways of dealing with this hazard including removing the paper faced insulation, or covering with the appropriate material.

Internal ID: 1434

IRC — Building



2018 GROUP A PROPOSED CHANGES TO THE I-CODES COLUMBUS COMMITTEE ACTION HEARINGS

April 15–23, 2018
Columbus Convention Center
Columbus, Ohio

First Printing

Publication Date: February 2018

Copyright © 2018

By

International Code Council, Inc.

ALL RIGHTS RESERVED. This 2018-2019 Code Development Cycle, Group A (2018) Proposed Changes to the 2018 *International Codes* is a copyrighted work owned by the International Code Council, Inc. Without advanced written permission from the copyright owner, no part of this book may be reproduced, distributed, or transmitted in any form or by any means, including, without limitations, electronic, optical or mechanical means (by way of example and not limitation, photocopying, or recording by or in an information storage retrieval system). For information on permission to copy material exceeding fair use, please contact: Publications, 4051 West Flossmoor Road, Country Club Hills, IL 60478 (Phone 1-888-422-7233).

Trademarks: "International Code Council," the "International Code Council" logo are trademarks of the International Code Council, Inc.

PRINTED IN THE U.S.A.

IRC Building Code Change Proposals

The following code change proposals are labeled as structural code change proposals because they are proposals for changes to sections in chapters of the International Building Code that are designated as the responsibility of the IRC-Building Code Development Committee (see page ix of the Introductory pages of this monograph), which meets in the Group B cycle in 2019. However the changes included in this Group A code development cycle are to sections of the code that are the responsibility of a different IRC Code Development Committee— either the IRC-Mechanical or the IRC-Plumbing Committee.

The committee assigned for each code change proposal is indicated in a banner statement near the beginning of the proposal. Both the IBC-Fire Safety and the IBC-General hearing orders are include here for your reference.

2018 GROUP A – PROPOSED CHANGES TO THE INTERNATIONAL RESIDENTIAL CODE – PLUMBING/ MECHANICAL

PLUMBING/MECHANICAL CODE COMMITTEE

W. Travis Lindsey, MCP, Chair

Sr. Plans Examiner
City of Scottsdale
Scottsdale, AZ

Marguerite Carroll, Vice Chair

Codes and Regulatory Services Manager
Underwriters Laboratories
Fremont, CA

John Ainslie

Rep: National Association of Home Builders
Owner
Ainslie Group
Virginia Beach, VA

Richard C. Anderson

Division Manager/Deputy Building Official
City of Austin
Austin, TX

Roland Asp, CET

Manager of Installation Standards
National Fire Sprinkler Association
Linthicum Heights, MD

Pennie Feehan

Rep: Copper Development Association
Owner
Pennie L. Feehan Consulting
Palm Springs, CA

R. L. Ric Johnson, CAPS, DHTI+

Rep: National Association of Home Builders
President/CEO
Right at Home Technologies
Ada, OH

Nick McAndrew, PE

Professional Engineer I (Civil/Construction)
NY Department of State Division of Buildings
Standards and Codes
Albany, NY

David W. Perry

Sr. Combination Inspector
City of Richardson
Richardson, TX

Thomas Polino

Plumbing Subcode Official
West Windsor Township
West Windsor, NJ

Loren K. Swanson, BSIE

Rep: National Association of Home Builders
Retired from Southern Michigan Co.
Jackson, MI

Jeremy Wright

Rep: National Association of Home Builders
President
J. Wright Building Company
J. Wright Home Design
Birmingham, AL

Staff Secretariat:

Fred Grable, PE

Senior Staff Engineer - Plumbing
International Code Council
Central Regional Office
Country Club Hills, IL

Gregg Gress

Senior Technical Staff
International Code Council
Central Regional Office
4051 W. Flossmoor Rd
Country Club Hills, IL

TENTATIVE ORDER OF DISCUSSION 2018 PROPOSED CHANGES TO THE INTERNATIONAL RESIDENTIAL CODE – MECHANICAL

The following is the tentative order in which the proposed changes to the code will be discussed at the public hearings. Proposed changes which impact the same subject have been grouped to permit consideration in consecutive changes.

Proposed change numbers that are indented are those which are being heard out of numerical order. Indentation does not necessarily indicate that one change is related to another. Proposed changes may be grouped for purposes of discussion at the hearing at the discretion of the chair. Note that some RM code change proposals may not be included on this list, as they are being heard by another committee.

RM1-18	M78-18 Part II
P1-18 Part II	RM32-18
RB5-18	RM33-18
RM2-18	RM34-18
RM3-18	RM35-18
RM4-18	M119-18 Part II
RM5-18	RM36-18
RM6-18	RM37-18
RM7-18	RM38-18
M86-18 Part II	RM39-18
RM8-18	RM40-18
RM9-18	RM41-18
RM10-18	RM42-18
RM11-18	RM43-18
RM12-18	RM44-18
RM13-18	RM45-18
RM14-18	RM46-18
RM15-18	
RM16-18	
M53-18 Part II	
RM17-18	
RM18-18	
RM19-18	
RM20-18	
RM21-18	
RM22-18	
RM23-18	
RB1-18	
RB2-18	
RB3-18	
RM24-18	
RM25-18	
RM26-18	
RM27-18	
RM28-18	
RM29-18	
RM30-18	
RM31-18	

TENTATIVE ORDER OF DISCUSSION 2018 PROPOSED CHANGES TO THE INTERNATIONAL RESIDENTIAL BUILDING CODE – PLUMBING

The following is the tentative order in which the proposed changes to the code will be discussed at the public hearings. Proposed changes which impact the same subject have been grouped to permit consideration in consecutive changes.

Proposed change numbers that are indented are those which are being heard out of numerical order. Indentation does not necessarily indicate that one change is related to another. Proposed changes may be grouped for purposes of discussion at the hearing at the discretion of the chair. Note that some RP code change proposals may not be included on this list, as they are being heard by another committee.

P1-18 Part II	RP12-18
RB4-18	P131-18 Part II
P58-18 Part II	P132-18 Part II
RP1-18	P103-18 Part II
RP2-18	P106-18 Part II
P11-18 Part II	P109-18 Part II
P8-18 Part II	P113-18 Part II
P7-18 Part II	P133-18 Part II
RP3-18	RP13-18
P63-18 Part II	P115-18 Part II
P44-18 Part II	RP14-18
P45-18 Part II	
P46-18 Part II	
RP4-18	
P47-18 Part II	
P50-18 Part II	
P48-18 Part II	
P33-18 Part II	
P71-18 Part II	
F14-18 Part II	
P97-18 Part II	
P98-18 Part II	
P79-18 Part II	
P82-18 Part II	
RP16-18	
P77-18 Part II	
RP5-18	
RP6-18	
RP7-18	
RP8-18	
RP9-18	
RP10-18	
RP15-18	
P87-18 Part II	
P88-18 Part II	
RP11-18	
P89-18 Part II	

RB1-18

IRC: R303.4

Proponent: Mike Moore, representing Broan-NuTone (mmoore@newportventures.net)

2018 International Residential Code

Revise as follows:

R303.4 Mechanical ventilation. Where the air infiltration rate of a *dwelling unit* is 5 air changes per hour or less where tested with a blower door at a pressure of 0.2 inch w.c (50 Pa) in accordance with Section N1102.4.1.2, the *dwelling unit* shall be provided with whole-house mechanical ventilation and local exhaust for kitchens in accordance with ~~Section M1505.4.~~ Chapter 15.

Reason:

Kitchens are typically the largest source of indoor air pollution in U.S. homes. During cooking, harmful pollutants are released in concentrations that have been shown to increase the frequency of cancer, lung disease, heart disease, asthma aggravation, and hospital visits. In residential kitchens, concentrations of these pollutants frequently exceed maximum safe levels set by the World Health Organization and U.S. National Ambient Air Quality Standards. According to research cited by the World Health Organization, "long-term exposure to PM_{2.5} (particulate matter with a diameter of 2.5 microns or less, see graphic below for relative size) is associated with an increase in the long-term risk of cardiopulmonary mortality by 6–13% per 10 µg/m³ of PM_{2.5}." Without kitchen exhaust, residential kitchens regularly see concentrations that are easily hundreds of µg/m³ higher than outdoor levels (see Chart 1).

Cooks (all of us and our spouses if we're so fortunate) face the highest exposure to cooking pollutants, but if not captured at the source, these pollutants quickly find their way to bedrooms in far corners of the home. In tight homes, the concentration and associated damage caused by cooking pollutants can increase dramatically, as pollutants have nowhere to go. Opening a window can help to reduce kitchen pollutant levels, but it's as likely to spread the pollutants to other corners of the home as it is to exhaust them to the outdoors. In these locations, pollutants are deposited on surfaces, and re-enter the breathing zone when disturbed. All considered, building homes tight without providing mechanical kitchen exhaust presents an enormous liability for the industry and a disservice to the families that buy homes.

Builders are doing a great job constructing tight homes. But this shouldn't happen to the detriment of home owner health and safety. The IRC's charge in Section R101.3 is to IRC to "safeguard public safety, health, and general welfare through...ventilation" (among other methods). Approve this proposal to ensure that our ventilation systems are keeping pace with today's tight construction.

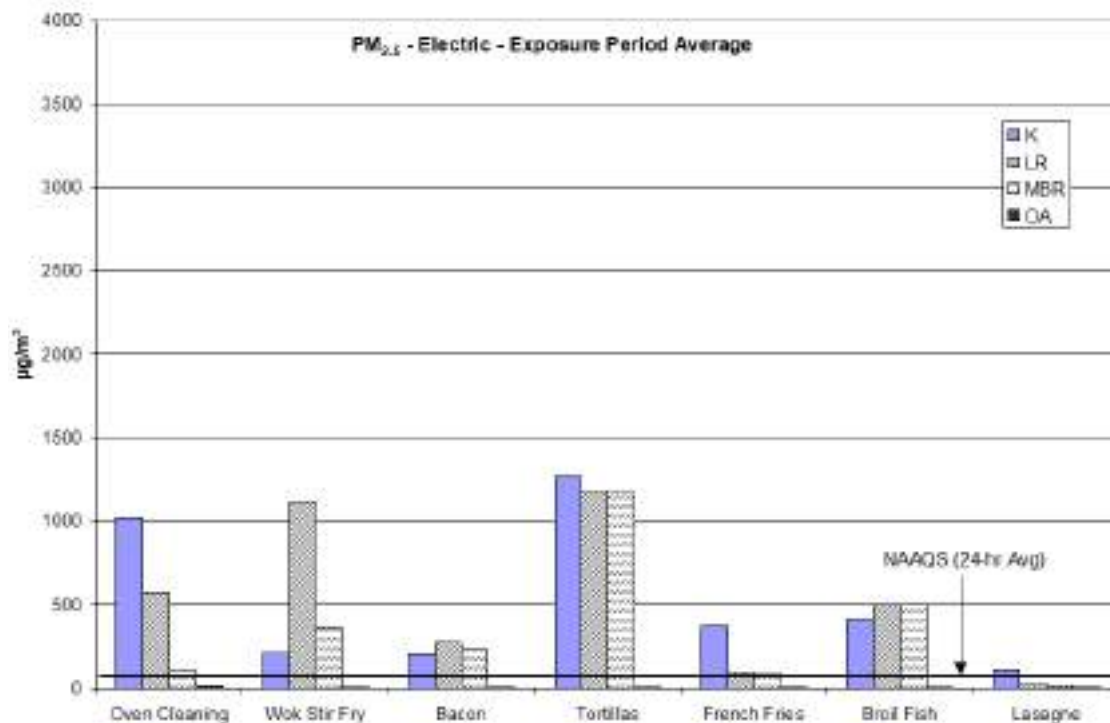

Chart 1. Concentration of PM_{2.5} (particulate matter with a diameter < 2.5 microns: the most harmful cooking pollutant)

during various cooking events in a test home. According to the World Health Organization, "long-term exposure to PM_{2.5} is associated with an increase in the long-term risk of cardiopulmonary mortality by 6–13% per 10 µg/m³ of PM_{2.5} (8–10)." Chart data sourced from Fortmann et al.

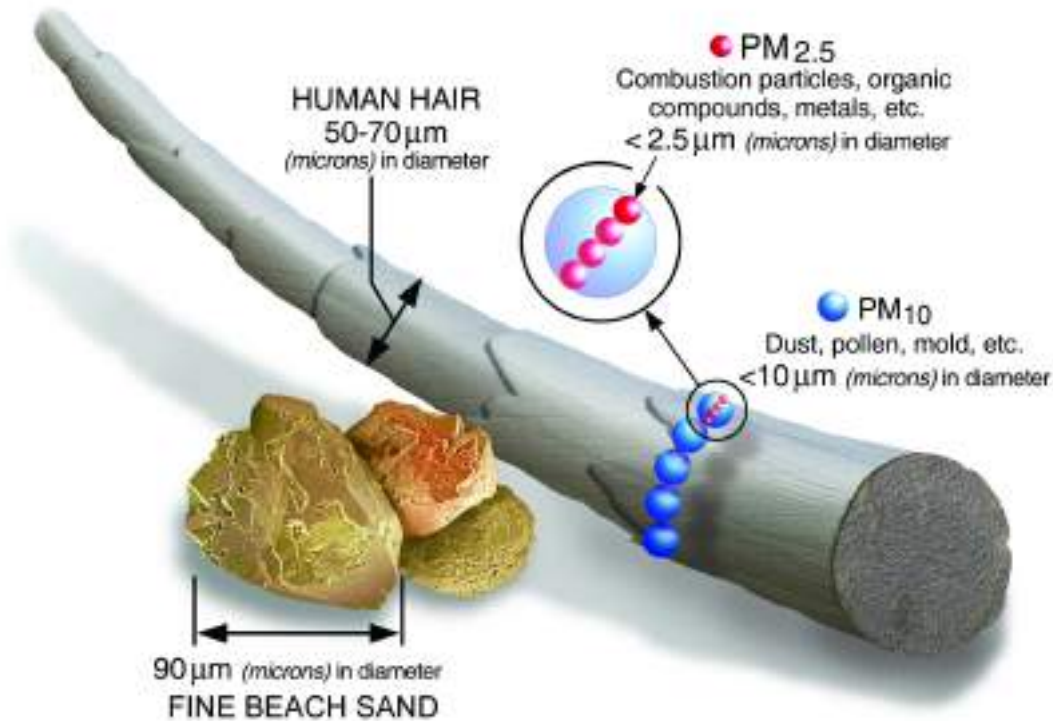

Figure 1. Size of particulate matter. Source: <https://www.epa.gov/pm-pollution/particulate-matter-pm-basics>.

Bibliography:

- Abdullahi, K. L., Delgado-Saborit, J. M., & Harrison, R. M. (2013). Emissions and indoor concentrations of particulate matter and its specific chemical components from cooking: A review. *Atmospheric Environment*, 71, 260-294. doi: Doi 10.1016/j. Atmosenv.2013.01.061.
- Belanger, K., Gent, J. F., Triche, E. W., Bracken, M. B., & Leaderer, B. P.(2006). Association of indoor nitrogen dioxide exposure with respiratory symptoms in children with asthma. *American Journal of Respiratory and Critical Care Medicine*, 173(3), 297-303. doi: 10.1164/rccm.200408-1123OC.
- Buonanno, G., Morawska, L., & Stabile, L. (2009). Particle emission factors during cooking activities. *Atmospheric Environment*, 43(20), 3235-3242. doi:Doi 10.1016/j.Atmosenv.2009.03.044.
- Dennekamp, M., Howarth, S., Dick, C. A. J., Cherrie, J. W., Donaldson, K., &Seaton, A. (2001). Ultrafine particles and nitrogen oxides generated by gas and electric cooking. *Occupational and Environmental Medicine*, 58(8), 511-516.4.
- Fortmann, R., Kariher, P., & Clayton, R. (2001). *Indoor air quality: residential cooking exposures*. Sacramento, CA: Prepared for California Air Resources Board.
- Garrett, M. H., Hooper, M. A., Hooper, B. M., & Abramson, M. J. (1998).Respiratory symptoms in children and indoor exposure to nitrogen dioxide and gas stoves. *American Journal of Respiratory and Critical Care Medicine*,158(3), 891-895.
- Hansel, N. N., Breyse, P. N., McCormack, M. C., Matsui, E. C., Curtin-Brosnan, J., Williams, D. L., . . . Diette, G. B. (2008). A longitudinal study of indoor nitrogen dioxide levels and respiratory symptoms in inner-city children with asthma. *Environmental Health Perspectives*, 116(10), 1428-1432. doi:10.1289/ehp.11349.
- Logue JM, Price PN, Sherman MH, & Singer BC. 2012. A Method to Estimate the Chronic Health Impact of Air Pollutants in U.S. Residences. *Environmental Health Perspectives* 120(2): 216-222.
- Logue et al. (2014). *Pollutant exposures from natural gas cooking burners: a simulation based assessment for Southern California.* Lawrence Berkeley National Laboratory. LBNL-6712E.
- Moschandreas, D. J., & Relwani, S. M. (1989). Field-Measurements of NO₂ Gas Range-Top Burner Emission Rates. *Environment International*, 15(1-6),489-492.5.
- Moschandreas, D., Relwani, S., Johnson, D., & Billick, I. (1986). Emission Rates from Unvented Gas Appliances. *Environment International*, 12(1-4),247-254.6. EPA. Fine Particle Designations. Available at

<http://www.epa.gov/pmdesignations/faq.htm>. Sourced on December 10, 2014.

McKenna, M.T., C.M. Michaud, C.J.L. Murray, and J.S. Marks. (2005). Assessing the burden of disease in the United States using disability adjusted life years. *Am J Prev Med.*: 28(5):415-423.9.

Nicole, W. (2014). Cooking Up Indoor Air Pollution: Emissions from NaturalG as Stoves. *Environ Health Perspect*: 122-A27.

Offerman, F.J. (2009). Ventilation and indoor air quality in new homes. PIER Collaborative Report. California Energy Commission & California Environmental Protection Agency Air Resources Board.

Seaman, V. Y., Bennett, D. H., & Cahill, T. M. (2009). Indoor acrolein emission and decay rates resulting from domestic cooking events. *Atmospheric Environment*, 43(39), 6199-6204. doi:10.1016/j.atmosenv.2009.08.043.

Singer, B. C., Apte, M. G., Black, D. R., Hotchi, T., Lucas, D., Lunden, M., Sullivan, D. P. (2010). Natural Gas Variability in California: Environmental Impacts and Device Performance: Experimental Evaluation of Pollutant Emissions from Residential Appliances. Sacramento CA: California Energy Commission.

Smith PA. (2013). The Kitchen as a Pollution Hazard. *New York Times*. http://well.blogs.nytimes.com/2013/07/22/the-kitchen-as-a-pollution-hazard/?_r=0. Accessed December 18, 2015.

Wallace LA, Emmerich SJ, & Howard-Reed C. 2004. Source strengths of ultrafine and fine particles due to cooking with a gas stove. *Environmental Science & Technology*, 38(8), 2304-2311.

World Health Organization. 2013. Health effects of particulate matter. ISBN 978 92 890 0001 7. Available at: http://www.euro.who.int/__data/assets/pdf_file/0006/189051/Health-effects-of-particulate-matter-final-Eng.pdf. Sourced on: Jan. 1, 2018.

Zhang Q, Gangupomu RH, Ramirez D, & Zhu Y. 2010. Measurement of Ultrafine Particles and Other Air Pollutants Emitted by Cooking Activities. *Int. J. Environ. Res. Public Health* 7: 1744-1759.

Cost Impact

The code change proposal will increase the cost of construction .

For those units that do not already install kitchen exhaust, the cost of construction will increase, depending on equipment selection. Exhaust hoods start around \$50 retail (e.g., Broan economy hood #403001, 2-speed, moving 160 cfm, priced on zoro.com at \$47.60 with tax and shipping on January 11, 2018). Installed cost to the GC for ducting is estimated at ~\$9.85 per linear foot for 3.25"x10" galvanized sheet metal duct (RS Means, 2015, Section 23 31 13.13.0500), and a damper would cost about \$15 retail.

Internal ID: 1949

RB2-18

IRC: R303.4

Proponent: Mike Moore, Newport Ventures, representing The Home Ventilating Institute (mmoore@newportventures.net)

2018 International Residential Code

Revise as follows:

R303.4 Mechanical ventilation. ~~Where the air infiltration rate of a dwelling unit is 5 air changes per hour or less where tested with a blower door at a pressure of 0.2 inch w.c (50 Pa) in accordance with Section N1102.4.1.2, the dwelling unit is served by space-heating or cooling equipment, it shall be provided with whole-house mechanical ventilation in accordance with Section M1505.4.~~

Reason:

Building tight dwelling units has benefits of energy efficiency; improved comfort; and improved odor, rodent, and sound control. Tight buildings are typically the byproduct of better fire and smoke control as well. Beginning with the 2012 IRC, building tight has been code minimum practice, which is good. However, we learned in the 1970s that building tight without mechanically ventilating results in sick building syndrome.

So, since 2012, the code has required tight dwelling units to also be provided with mechanical ventilation. The problem is that we've heard from ICC staff, code officials, builders, and design professionals that it's hard to follow the code language requirements. Currently, we have a 5-step process to identify that mechanical ventilation is required for all IRC dwelling units that introduces needless confusion. Here's what the process looks like:

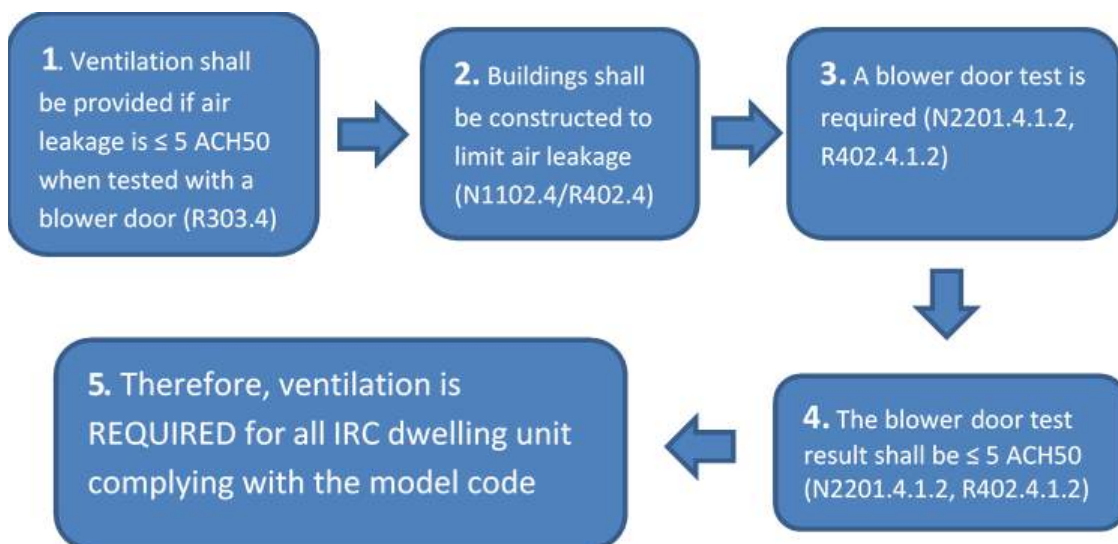

Instead of a 5-step process, we can simplify the code and enforcement by jumping straight to the conclusion: ventilation is required for all dwelling units. This proposal does exactly that. Additionally, this proposal introduces an exception for the mechanical ventilation requirement in climates and situations where natural ventilation is expected to provide all of the climate control and ventilation needed (i.e., when no space-heating or cooling equipment is provided). A similar exception exists in ASHRAE 62.2.

Cost Impact

The code change proposal will not increase or decrease the cost of construction .

Ventilation is already required for IRC dwelling units, so this proposal will not increase the cost of construction. For dwelling units without heating or cooling (e.g., seasonal cabins), this code change proposal will decrease the cost of construction.

Internal ID: 531

RB3-18

IRC: R303.1

Proponent: Mike Moore, Newport Ventures, representing Broan-NuTone (mmoore@newportventures.net)

2018 International Residential Code

R303.1 Habitable rooms. Habitable rooms shall have an aggregate glazing area of not less than 8 percent of the floor area of such rooms. Natural *ventilation* shall be through windows, skylights, doors, louvers or other *approved* openings to the outdoor air. Such openings shall be provided with ready access or shall otherwise be readily controllable by the building occupants. The openable area to the outdoors shall be not less than 4 percent of the floor area being ventilated.

Exceptions:

1. The For habitable rooms other than kitchens, the glazed areas need not be openable where the opening is not required by Section R310 and a whole-house mechanical *ventilation* system or a mechanical ventilation system capable of producing 0.35 air changes per hour in the habitable rooms is installed in accordance with Section M1505.
2. For kitchens, the glazed areas need not be openable where the opening is not required by Section R310 and a local exhaust system is installed in accordance with Section M1505. Where the openable glazing area is less than 4 percent of the kitchen floor area, ductless kitchen exhaust shall not be permitted.
- ~~2.3.~~ The glazed areas need not be installed in rooms where Exception 1 is satisfied and artificial light is provided that is capable of producing an average illumination of 6 footcandles (65 lux) over the area of the room at a height of 30 inches (762 mm) above the floor level.
- ~~3.4.~~ Use of sunroom and patio covers, as defined in Section R202, shall be permitted for natural ventilation if in excess of 40 percent of the exterior sunroom walls are open, or are enclosed only by insect screening.

Reason:

Prior to 2012, this section permitted users to specify "mechanical ventilation systems capable of producing 0.35 air changes per hour" or whole-house mechanical ventilation systems where an openable area of at least 4% of the habitable room's floor area is not provided. This proposed change would reintroduce the option for room-based mechanical ventilation systems, which are especially useful for additions or remodels. The proposed change is also consistent with Chapter 15's recognition that kitchens have different ventilation requirements than other habitable rooms. Namely, local exhaust, not whole-house mechanical ventilation that could be located in a far corner of the house, is needed for kitchens to ensure that cooking pollutants generated in the kitchen are captured and exhausted at their source. This language clarifies that IF the builder chooses to not provide the minimum openable glazing area in a kitchen, the kitchen shall be provided with ducted local exhaust in compliance with Chapter 15.

If approved, this change will provide more flexibility and can introduce cost savings for builders and buyers.

Cost Impact

The code change proposal will decrease the cost of construction .

This change adds options that can reduce cost and clarifies that if a kitchen range hood is installed in lieu of natural ventilation, the kitchen range hood shall be ducted to the exterior.

Internal ID: 1654

RB4-18

IRC: R202

Proponent: Janine Snyder, City of Thornton, representing Colorado Association of Plumbing & Mechanical Officials (CAPMO) (Janine.Snyder@cityofthornton.net); Guy Tomberlin, Fairfax County, VA, representing Fairfax County Building Division (guy.tomberlin@fairfaxcounty.gov)

2018 International Residential Code

Revise as follows:

[MP] CLEANOUT. An access opening in the drainage system ~~used~~ utilized for the removal of possible obstruction and ~~located to allow for access~~ of obstructions. Types of cleanouts include a removable plug or cap, and a removable fixture or fixture trap.

Reason:

By adding the text from the cleanout definition in the International Plumbing Code will not only add clarity by adding the types of cleanouts into the definition in International Residential Code, but will also maintain consistency between the two code definitions.

Cost Impact

The code change proposal will decrease the cost of construction .

This proposal will decrease the cost of construction by not requiring additional cleanouts to be installed where a water closet may be utilized.

Internal ID: 1372

RB5-18

IRC: R105.2

Proponent: Jim Tidwell, Tidwell Code Consulting, representing Honeywell (jimtiddwell@tccfire.com)

2018 International Residential Code

Revise as follows:

R105.2 Work exempt from permit. Exemption from *permit* requirements of this code shall not be deemed to grant authorization for any work to be done in any manner in violation of the provisions of this code or any other laws or ordinances of this *jurisdiction*. *Permits* shall not be required for the following:

- Building:
 1. One-story detached *accessory structures*, provided that the floor area does not exceed 200 square feet (18.58 m²).
 2. Fences not over 7 feet (2134 mm) high.
 3. Retaining walls that are not over 4 feet (1219 mm) in height measured from the bottom of the footing to the top of the wall, unless supporting a surcharge.
 4. Water tanks supported directly upon *grade* if the capacity does not exceed 5,000 gallons (18 927 L) and the ratio of height to diameter or width does not exceed 2 to 1.
 5. Sidewalks and driveways.
 6. Painting, papering, tiling, carpeting, cabinets, counter tops and similar finish work.
 7. Prefabricated swimming pools that are less than 24 inches (610 mm) deep.
 8. Swings and other playground equipment.
 9. Window awnings supported by an exterior wall that do not project more than 54 inches (1372 mm) from the exterior wall and do not require additional support.
 10. Decks not exceeding 200 square feet (18.58 m²) in area, that are not more than 30 inches (762 mm) above *grade* at any point, are not attached to a dwelling and do not serve the exit door required by Section R311.4.
- Electrical:
 1. *Listed* cord-and-plug connected temporary decorative lighting.
 2. Reinstallation of attachment plug receptacles but not the outlets therefor.
 3. Replacement of branch circuit overcurrent devices of the required capacity in the same location.
 4. Electrical wiring, devices, *appliances*, apparatus or *equipment* operating at less than 25 volts and not capable of supplying more than 50 watts of energy.
 5. Minor repair work, including the replacement of lamps or the connection of *approved* portable electrical *equipment* to *approved* permanently installed receptacles.
- Gas:
 1. Portable heating, cooking or clothes drying *appliances*.
 2. Replacement of any minor part that does not alter approval of *equipment* or make such *equipment* unsafe.
 3. Portable-fuel-cell *appliances* that are not connected to a fixed piping system and are not interconnected to a power grid.
- Mechanical:
 1. Portable heating *appliances*.
 2. Portable ventilation *appliances*.
 3. Portable cooling units.
 4. Steam, hot- or chilled-water piping within any heating or cooling *equipment* regulated by this code.
 5. Replacement of any minor part that does not alter approval of *equipment* or make such *equipment*

unsafe.

6. Portable evaporative coolers.
 7. Self-contained refrigeration systems containing 10 pounds (4.54 kg) or less of ~~refrigerant or non-flammable (A-1) refrigerant.~~
 8. Self-contained refrigeration systems containing non-flammable (A-1) refrigerants that are actuated by motors of 1 horsepower (746 W) or less.
 - ~~8.9.~~ Portable-fuel-cell *appliances* that are not connected to a fixed piping system and are not interconnected to a power grid.
- Plumbing:
 1. The stopping of leaks in drains, water, soil, waste or vent pipe; provided, however, that if any concealed trap, drainpipe, water, soil, waste or vent pipe becomes defective and it becomes necessary to remove and replace the same with new material, such work shall be considered as new work and a *permit* shall be obtained and inspection made as provided in this code.
 2. The clearing of stoppages or the repairing of leaks in pipes, valves or fixtures, and the removal and reinstallation of water closets, provided such repairs do not involve or require the replacement or rearrangement of valves, pipes or fixtures.

Reason:

The existing exemption for permitting residential size HVAC systems is founded on the fact that all refrigerants used in these systems have been non-flammable up until now. Changing out a system historically hasn't presented a significant risk. That changes with the introduction of flammable refrigerants. Changing out a system now may require significantly more design work to assure a safe installation. In addition, piping may need to be re-routed or replaced in some cases. If flammable refrigerants are used, it is no longer a simple equipment replacement, but a much more complex issue with significant safety risk. Requiring a permit will provide the jurisdiction with the opportunity to address that risk during the review and inspection process.

Cost Impact

The code change proposal will increase the cost of construction .

While the actual cost of construction isn't impacted, the requirement for a permit will add to the final cost.

Internal ID: 2065

2018 GROUP A – PROPOSED CHANGES TO THE INTERNATIONAL RESIDENTIAL CODE – PLUMBING/ MECHANICAL

PLUMBING/MECHANICAL CODE COMMITTEE

W. Travis Lindsey, MCP, Chair

Sr. Plans Examiner
City of Scottsdale
Scottsdale, AZ

Marguerite Carroll, Vice Chair

Codes and Regulatory Services Manager
Underwriters Laboratories
Fremont, CA

John Ainslie

Rep: National Association of Home Builders
Owner
Ainslie Group
Virginia Beach, VA

Richard C. Anderson

Division Manager/Deputy Building Official
City of Austin
Austin, TX

Roland Asp, CET

Manager of Installation Standards
National Fire Sprinkler Association
Linthicum Heights, MD

Pennie Feehan

Rep: Copper Development Association
Owner
Pennie L. Feehan Consulting
Palm Springs, CA

R. L. Ric Johnson, CAPS, DHTI+

Rep: National Association of Home Builders
President/CEO
Right at Home Technologies
Ada, OH

Nick McAndrew, PE

Professional Engineer I (Civil/Construction)
NY Department of State Division of Buildings
Standards and Codes
Albany, NY

David W. Perry

Sr. Combination Inspector
City of Richardson
Richardson, TX

Thomas Polino

Plumbing Subcode Official
West Windsor Township
West Windsor, NJ

Loren K. Swanson, BSIE

Rep: National Association of Home Builders
Retired from Southern Michigan Co.
Jackson, MI

Jeremy Wright

Rep: National Association of Home Builders
President
J. Wright Building Company
J. Wright Home Design
Birmingham, AL

Staff Secretariat:

Fred Grable, PE

Senior Staff Engineer - Plumbing
International Code Council
Central Regional Office
Country Club Hills, IL

Gregg Gress

Senior Technical Staff
International Code Council
Central Regional Office
4051 W. Flossmoor Rd
Country Club Hills, IL

TENTATIVE ORDER OF DISCUSSION 2018 PROPOSED CHANGES TO THE INTERNATIONAL RESIDENTIAL CODE – MECHANICAL

The following is the tentative order in which the proposed changes to the code will be discussed at the public hearings. Proposed changes which impact the same subject have been grouped to permit consideration in consecutive changes.

Proposed change numbers that are indented are those which are being heard out of numerical order. Indentation does not necessarily indicate that one change is related to another. Proposed changes may be grouped for purposes of discussion at the hearing at the discretion of the chair. Note that some RM code change proposals may not be included on this list, as they are being heard by another committee.

RM1-18	M78-18 Part II
P1-18 Part II	RM32-18
RB5-18	RM33-18
RM2-18	RM34-18
RM3-18	RM35-18
RM4-18	M119-18 Part II
RM5-18	RM36-18
RM6-18	RM37-18
RM7-18	RM38-18
M86-18 Part II	RM39-18
RM8-18	RM40-18
RM9-18	RM41-18
RM10-18	RM42-18
RM11-18	RM43-18
RM12-18	RM44-18
RM13-18	RM45-18
RM14-18	RM46-18
RM15-18	
RM16-18	
M53-18 Part II	
RM17-18	
RM18-18	
RM19-18	
RM20-18	
RM21-18	
RM22-18	
RM23-18	
RB1-18	
RB2-18	
RB3-18	
RM24-18	
RM25-18	
RM26-18	
RM27-18	
RM28-18	
RM29-18	
RM30-18	
RM31-18	

RM1-18

IRC: Chapter 21, 202 (New)

Proponent: Mark Fasel, representing Viega LLC (mark.fasel@viega.us)

2018 International Residential Code

CHAPTER 21 HYDRONIC PIPING

Add new definition as follows:

PRESS-CONNECT JOINT A permanent mechanical joint incorporating an elastomeric seal or an elastomeric seal and corrosion-resistant grip or bite ring. The joint is made with a pressing tool and jaw or ring approved by the fitting manufacturer.

Reason:

Currently the IRC does not include the definition of Press-Connect Joint which is used in the text of the code in IRC section M2103.3. Including this definition will align the definitions as similarly provided for in the IMC and IPC.

Cost Impact

The code change proposal will not increase or decrease the cost of construction .

This proposed definition will not increase or decrease cost of construction as it defines a pipe joining method already referenced in the code.

Internal ID: 787

RM2-18

IRC: M1305.1.4 (New), M1305.1.4.1 (New), M1305.1.4.2 (New)

Proponent: Brent Ursenbach, representing Salt Lake County Planning and Development Services
(bursenbach@slco.org)

2018 International Residential Code

Add new text as follows:

M1305.1.4 Equipment and appliances on roofs or elevated structures. Where equipment requiring access or appliances are located on an elevated structure or the roof of a building such that personnel will have to climb higher than 16 feet (4877 mm) above grade to access such equipment or appliances, an interior or exterior means of access shall be provided. Such access shall not require climbing over obstructions greater than 30 inches (762 mm) in height or walking on roofs having a slope greater than four units vertical in 12 units horizontal (33-percent slope). Where access involves climbing over parapet walls, the height shall be measured to the top of the parapet wall. Roof access shall not require the use of portable ladders except where roof access is from the building interior through an attic space, or through a hatch in the roof assembly, and the height necessary to climb on such portable ladder does not exceed 16 feet. Roof hatches used for access shall comply with the dimension requirements for an attic access. Permanent ladders installed to provide the required access shall comply with the following minimum design criteria:

1. The side railing shall extend above the parapet or roof edge not less than 30 inches (762 mm).
2. Ladders shall have rung spacing not to exceed 14 inches (356 mm) on center. The uppermost rung shall be not greater than 24 inches (610 mm) below the upper edge of the roof hatch, roof or parapet, as applicable.
3. Ladders shall have a toe spacing not less than 6 inches (152 mm) deep.
4. There shall be not less than 18 inches (457 mm) between rails.
5. Rungs shall have a diameter not less than 0.75-inch (19.1 mm) and be capable of withstanding a 300-pound (136 kg) load.
6. Ladders over 30 feet (9144 mm) in height shall be provided with offset sections and landings capable of withstanding 100 pounds per square foot (488 kg/m²). Landing dimensions shall be not less than 18 inches (457 mm) and not less than the width of the ladder served. A guard rail shall be provided on all open sides of the landing.
7. Climbing clearance. The distance from the centerline of the rungs to the nearest permanent object on the climbing side of the ladder shall be not less than 30 inches (762 mm) measured perpendicular to the rungs. This distance shall be maintained from the point of ladder access to the bottom of the roof hatch. A minimum clear width of 15 inches (381 mm) shall be provided on both sides of the ladder measured from the midpoint of and parallel with the rungs except where cages or wells are installed.
8. Landing required. The ladder shall be provided with a clear and unobstructed bottom landing area having a minimum dimension of 30 inches (762 mm) by 30 inches (762 mm) centered in front of the ladder.
9. Ladders shall be protected against corrosion by approved means.
10. Access to ladders shall be provided at all times.

Catwalks installed to provide the required access shall be not less than 24 inches (610 mm) wide and shall have railings as required for service platforms.

M1305.1.4.1 Sloped roofs. Where appliances, equipment, fans or other components that require service are installed on a roof having a slope of three units vertical in 12 units horizontal (25-percent slope) or greater and having an edge more than 30 inches (762 mm) above grade at such edge, a level platform shall be provided on each side of the appliance or equipment to which access is required for service, repair or maintenance. The platform shall be not less than 30 inches (762 mm) in any dimension and shall be provided with guards. The guards shall extend not less than 42 inches (1067 mm) above the platform, shall be constructed so as to prevent the passage of a 21-inch-diameter (533 mm) sphere and shall comply with the loading requirements for guards specified in this code. Access shall not require walking on roofs having a slope greater than four units vertical in 12 units horizontal (33-percent slope). Where access involves obstructions greater than 30 inches (762 mm) in height, such obstructions shall be provided with ladders installed in accordance with Section M1305.1.4 or stairways installed in accordance with the requirements specified in this code in the path of travel to and from appliances, fans or equipment requiring service.

M1305.1.4.2 Electrical requirements. Electrical requirements. A receptacle outlet shall be provided at or near the equipment location in accordance with Section E3901.12.

Reason:

The IRC and IMC have always included provisions for the safe access to appliances and equipment, for inspection, maintenance, repair and replacement, in rooms, attics and under-floor spaces. The IMC has also included requirements for appliances located on roofs or elevated structures, the location where the greatest hazards exist; however, the IRC is silent on access to appliances and equipment on roofs or elevated structures.

It's not logical to have a code which protects safety of those servicing commercial HVAC systems located on roofs and ignores the safety of those servicing HVAC equipment located roofs of SFD, duplexes and townhouses. Homeowners often perform annual maintenance on their own HVAC systems. Is their safety less important than the safety of the HVAC technician?

This proposal is similar to the requirements from the IMC; however this proposal allows the use of a portable ladder, for use inside the dwelling, for access to the attic or directly on the roof through roof rafters and a roof access.

This has become a significant issue in recent years with the trend of building 2 and 3 story townhouses, with RTU's or condensing units located on the roof. Many of these projects have roof more than 30' above grade.

-

Cost Impact

The code change proposal will increase the cost of construction .

This proposal will increase the cost of construction only in situations where HVAC systems are installed on roofs or elevated structures higher than 16 feet.

Internal ID: 1444

RM3-18

IRC: M1307.7 (New)

Proponent: Pennie Feehan, representing Plumbing, Mechanical, and Fuel Gas Code Action Committee (PMGCAC@iccsafe.org)

2018 International Residential Code

Add new text as follows:

M1307.7 Prohibited support. Gypsum board shall not be used as a support base under an appliance.

Reason:

If appliances are installed resting on gypsum board, the board can compress, degrade from heat, moisture and vibration and crumble, with the result being movement and settling of the appliance which would put stress on gas piping, vent connectors, chimney connectors, electrical connections and ductwork. Gypsum board is not intended to be a support base for vertical deadloads.

This proposal is submitted by the ICC Plumbing/Mechanical/Gas Code Action Committee (PMG CAC). The PMG CAC was established by the ICC Board of Directors to pursue opportunities to improve and enhance the International Codes or portions thereof that were under the purview of the PMG CAC. In 2017 the PMG CAC held one face-to-face meeting and 11 conference call meetings. Numerous interested parties attended the committee meetings and offered their input.

Cost Impact

The code change proposal will not increase or decrease the cost of construction .

This proposal will not increase the cost of construction because no additional labor, materials, equipment, appliances or devices are mandated beyond what is currently required by the code.

Internal ID: 379

RM4-18

IRC: M1308.3 (New)

Proponent: Howard Ahern, representing Airex Manufacturing (howard.ahern@airexmf.com)

2018 International Residential Code

Add new text as follows:

M1308.3 Wall Penetration Sealing. Where pipe penetrates a building envelope wall, the annular space between the outside of the pipe and the inside of a pipe sleeve and the annular space between the outside of a pipe sleeve and the opening in a building envelope wall shall be sealed with caulking material or closed with a gasketing system. Caulking materials, and gasketing systems shall allow for expansion and contraction of material and mechanical vibration, shall be designed for the conditions at the location of the penetration, and shall be compatible with the pipe, sleeve and building materials in contact with the sealing materials. Annular spaces created by pipes penetrating fire-resistance-rated assemblies or membranes of such assemblies shall be sealed or closed in accordance with this code

Reason:

There are no sections for sealing wall pipe penetrations for mechanical systems.

This change provides for the annular sealing of pipe penetrations for mechanical systems, some mechanical piping may vibrate and this change shall allow for the proper sealing of these penetrations.

Cost Impact

The code change proposal will not increase or decrease the cost of construction .

Sealing of the pipe wall penetration should be part of standard construction practice, and not lead to increased cost , however sealing of refrigerant piping should not increase cost , also the IBC requires rodent proofing as well

Internal ID: 385

RM5-18

IRC: M1309 (New)

Proponent: Craig Conner, representing self (craig.conner@mac.com); Jani Palmer (Palmer.Janise@epa.gov)

2018 International Residential Code

Add new text as follows:

M1309 Radon testing. Radon testing shall be performed for radon zone 1, as defined in Appendix F. This section requires that tests be performed and the results be provided to the owner, but does not require a specific test result..

Exceptions:

1. Testing is not required where the authority having jurisdiction has defined the radon zone as Zone 2 or 3.
2. Testing is not required where the occupied space is located above an open space.

Testing shall be performed as specified in items 1 through 10:

1. Testing shall be performed after the dwelling passes its air tightness test.
2. Testing shall be performed after the radon control system installation is complete. If the system has an active fan, the residence shall be tested with the fan operating.
3. Testing shall be performed at the lowest floor level that will be occupied, whether or not the space is finished. Spaces that are physically separated and served by different HVAC systems shall be tested separately.
4. Testing shall not be performed in a closet, hallway, stairway, laundry room, furnace room, bathroom or kitchen.
5. Testing shall be performed with a commercially available radon test kit or with a continuous radon monitor that can be calibrated. Testing with test kits shall include two tests, and the test results shall be averaged. Testing shall be in accordance with the testing device manufacturer's instructions.
6. Testing shall be performed by the builder, a registered design professional, or an approved third party.
7. Testing shall be conducted over a period of not less than 48 hours or not less than the period specified by the testing device manufacturer, whichever is longer. The initial testing shall begin prior to occupancy, but need not be completed prior to occupancy.
8. Test results shall be provided directly to the owner by the test lab or testing party and shall be delivered either before or after occupancy.
9. An additional pre-paid test kit shall be provided to the owner to utilize at the owner's discretion. The test kit shall include mailing or emailing the results from the testing lab to the owner.
10. The owner or registered design professional shall be notified in writing prior to occupancy, stating one of the following:
 - 10.1. A radon test result of 4 pCi/L or above is the 'action level' set by EPA. The EPA recommends radon reduction measures to lower radon levels below 4 pCi/L."
 - 10.2. For a radon test result of 4 pCi/L or above [name of builder or authority having jurisdiction] recommends radon reduction measures to lower radon levels below 4 pCi/L."

Reason:

Radon tests are the only way to know if a residence has significant levels of radon. The test kits are inexpensive and easy to use. This change is designed not to delay the sale or occupancy of the home. Testing in radon zone 1 provides information for areas that tend to have higher levels of radon.

Cost Impact

The code change proposal will increase the cost of construction .

Multiple companies make inexpensive radon test kits. This change would require two tests which are averaged, plus a third test kit to be left with the owners. Three tests including pre-paid testing, postage and tax will cost less than \$80, often less than \$50.

RM6-18

IRC: M1305.1.4.4 (New)

Proponent: Guy McMann, representing Colorado Association of Plumbing and Mechanical Officials (CAPMO) (gcmann@jeffco.us); Troy Jones, representing Jefferson County Division of Building Safety (tjones@jeffco.us)

2018 International Residential Code

Add new text as follows:

M1305.1.4.4 Ladder Required. Where mechanical equipment or appliances that require servicing are located in under floor spaces that are greater than 30 inches in depth below the floor level, the access openings to such spaces shall be equipped with an approved, permanently affixed ladder capable of withstanding a 300-pound (136.1 kg) load. Such ladders shall be securely fastened to the structure at the top and bottom, shall have a rung spacing of not less than 14 inches (356 mm) on center and a rail spacing of not less than 18 inches (457 mm) between rails. Ladders constructed of dimensional lumber shall be not less than nominal two by four members. Fasteners shall be in accordance with Table R602.3 (1) item 16 for end nailing or other approved fastening methods.

Reason:

The code tells us how to go up but it doesn't tell us how to go down. Ladders constructed of wood in many instances lack the quality in construction to support the weight imposed on them. Often the rungs break exposing the fasteners that can seriously wound the person accessing the ladder. There needs to be a ladder capable of withstanding the repeated use that accessing appliances and equipment in crawlers and under floor spaces require. The spacing requirements are the same as found in the IMC along with the loading requirements. This proposal provides much flexibility in construction. Guidance for using wood has been provided. Other methods of construction shall be up for approval by the AHJ.

Cost Impact

The code change proposal will increase the cost of construction .

This requirement may increase cost as it has not been required to install a ladder in a under floor access opening to date although many just do it anyway in a haphazard way.

Internal ID: 170

RM7-18

IRC: M1401.1

Proponent: David Bixby, Air Conditioning Contractors of America (ACCA), representing Air Conditioning Contractors of America (bixster1953@yahoo.com)

2018 International Residential Code

M1401.1 Installation. Heating and cooling *equipment* and *appliances* shall be installed in accordance with the manufacturer's instructions and the requirements of this code. HVAC systems shall be installed in compliance with ACCA 5 QI.

Reason:

ACCA 5 QI details nationally-recognized minimum criteria for the proper installation of HVAC systems in new and existing residential and commercial buildings. This Standard provides a universally accepted definition for quality installation across a broad spectrum of the HVAC industry (e.g., manufacturers, distributors, contractors, user groups, customers, utilities, efficiency advocates, trade associations, professional societies, and governmental agencies). In this Standard, the QI elements focus on the application and how well the system is selected and actually installed. ACCA 5 QI is also a consensus-based ANSI standard. A proposal to add ACCA 5 QI to Chapter 44, Referenced Standards, has also been submitted.

Cost Impact

The code change proposal will not increase or decrease the cost of construction .

Cost impacts for using ACCA 5 QI would be minimal, other than some extra time involved. Installers will have to perform calculations for ventilation, heat loss/gain, ensure proper equipment sizing and selection, in order to comply. This is a guide for making sure the industry performs quality installations based on current industry practice. Code officials will have to verify and document compliance.

Analysis: A review of the standard proposed for inclusion in the code, with regard to the ICC criteria for referenced standards (Section 3.6 of CP#28) will be posted on the ICC website on or before April 2, 2018.

Internal ID: 1873

RM8-18

IRC: M1404.1

Proponent: Jim Tidwell, representing Honeywell (jimtidwell@tccfire.com)

2018 International Residential Code

Revise as follows:

M1404.1 Compliance. Refrigeration cooling *equipment* shall comply with Section M1411 and ANSI/ASHRAE 15.

Reason:

ASHRAE 15 is the accepted standard for the installation of refrigeration equipment, and should be referenced by the IRC. We believe this was an oversight, and this change corrects that oversight. The IMC references this standard as well.

Cost Impact

The code change proposal will not increase or decrease the cost of construction .

The code change may change the cost of construction, either by increasing it or decreasing it depending upon the system being installed. Referencing a national standard for installation criteria should streamline the overall process.

Internal ID: 2258

RM9-18

IRC: M1411.3.1.2 (New)

Proponent: Guy McMann, Jefferson County Colorado, representing Colorado Association of Plumbing and Mechanical Officials (CAPMO) (gcmcmann@jeffco.us)

2018 International Residential Code

Add new text as follows:

M1411.3.1.2 Appliance, equipment and insulation in pans. Where appliances, equipment or insulation are subject to water damage when auxiliary drain pans fill, that portion of the appliance, equipment and insulation shall be installed above the rim of the pan. Supports located inside of the pan to support the appliance or equipment shall be water resistant and approved.

Reason:

This is editorial in nature and is missing from this code. This can be found in the IMC Section 307.2.3.2 and in the IPC. This addition will make the IRC consistent with the other codes.

Cost Impact

The code change proposal will not increase or decrease the cost of construction .

This change is editorial in nature.

Internal ID: 152

RM10-18

IRC: M1411.6

Proponent: Pennie Feehan, representing Plumbing, Mechanical, and Fuel Gas Code Action Committee (PMGCAC@iccsafe.org)

2018 International Residential Code

Revise as follows:

M1411.6 Insulation of refrigerant piping. Piping and fittings for refrigerant vapor (suction) lines shall be insulated with insulation having a thermal resistivity of not less than R-~~4~~3 and having external surface permeance not exceeding 0.05 perm [2.87 ng/(s • m² • Pa)] when tested in accordance with ASTM E96.

Reason:

This change is simply for consistency with the Chapter 11 energy provisions. The two insulation requirements did not match and caused confusion.

This proposal is submitted by the ICC Plumbing/Mechanical/Gas Code Action Committee (PMG CAC). The PMG CAC was established by the ICC Board of Directors to pursue opportunities to improve and enhance the International Codes or portions thereof that were under the purview of the PMG CAC. In 2017 the PMG CAC held one face-to-face meeting and 11 conference call meetings. Numerous interested parties attended the committee meetings and offered their input.

Cost Impact

The code change proposal will not increase or decrease the cost of construction .

This proposal will not increase the cost of construction because no additional labor, materials, equipment, appliances or devices are mandated beyond what is currently required by the code.

Internal ID: 484

RM11-18

IRC: M1411.8 (New)

Proponent: Howard Ahern, Airex Manufacturing, representing Airex Manufacturing (howard.ahern@airexmfg.com)

2018 International Residential Code

Add new text as follows:

M1411.8 Support of Refrigerant piping. Refrigerant piping & tubing shall be securely fastened to a permanent support within 6 feet of the compressor and within 3 feet of each subsequent bend or angle.

Reason:

This proposal will require support of the Refrigerant piping which vibrates and that can lead to damage of piping and joints from vibration and stress. Unfortunately many refrigerant pipes are not supported from the condenser, or the only support is foam , caulking in the walls penetration. This proposal will require supporting of the piping to ensure safety, reduce piping ,and joints damage from vibration and stress.

Bibliography:

Howard Ahern

representing Airex Manufacturing

National Sales and Technical Manager

Cost Impact

The code change proposal will decrease the cost of construction .

The piping should already be supported .

Internal ID: 2362

RM12-18

IRC: M1503.3

Proponent: Mike Moore, Newport Ventures, representing Broan-NuTone (mmoore@newportventures.net)

2018 International Residential Code

M1503.3 Exhaust discharge. Domestic cooking exhaust equipment shall discharge to the outdoors through a duct. The duct shall have a smooth interior surface, shall be air tight, shall be equipped with a backdraft damper and shall be independent of all other exhaust systems. Ducts serving domestic cooking exhaust equipment shall not terminate in an attic or crawl space or areas inside the building.

Listed and labeled ductless range hoods shall not be required to discharge to the outdoors where all of the following conditions are met:

~~**Exception:** Where installed in accordance with the manufacturer's instructions, and where mechanical or natural ventilation is otherwise provided, listed and labeled ductless range hoods shall not be required to discharge to the outdoors.~~

1. The equipment is installed in accordance with the manufacturer's instructions.
2. Mechanical or natural ventilation is otherwise provided in the cooking area.
3. The equipment is installed in a newly constructed dwelling unit other than single family, or is installed in an existing kitchen not having an existing range hood exhaust duct to the outdoors.

Reason:

Cooking is typically the largest source of indoor air pollution in homes, with concentrations of key pollutants frequently exceeding U.S. National Ambient Air Quality Standards. Over time, exposure to these pollutants has been shown to reduce length and quality of life. Clearly, kitchen ventilation is needed to comply with the purpose of the IRC to "safeguard public safety, health, and general welfare through...ventilation" (among other means). Unless captured and exhausted at the source, cooking pollutants spread rapidly through a home and deposit themselves on surfaces, only to be released again into the breathing zone when disturbed at a later time. For new construction in detached buildings, where the builder elects to install a range hood, requiring that the range hood be ducted is a very low-cost item with high returns in terms of occupant health. For reasons of constructability and cost sensitivity (not health), this proposal would only permit ductless range hoods when they are installed in an attached dwelling unit of new construction or when they are installed in an existing kitchen that doesn't have an pre-existing range hood exhaust duct.

Bibliography:

- Wallace, L. A., Emmerich, S. J., & Howard-Reed, C. (2004). Source strengths of ultrafine and fine particles due to cooking with a gas stove. *Environmental Science & Technology*, 38(8), 2304-2311.
- Singer, B. C., Apte, M. G., Black, D. R., Hotchi, T., Lucas, D., Lunden, M., Sullivan, D. P. (2010). Natural Gas Variability in California: Environmental Impacts and Device Performance: Experimental Evaluation of Pollutant Emissions from Residential Appliances. Sacramento CA: California Energy Commission.
- Dennekamp, M., Howarth, S., Dick, C. A. J., Cherrie, J. W., Donaldson, K., & Seaton, A. (2001). Ultrafine particles and nitrogen oxides generated by gas and electric cooking. *Occupational and Environmental Medicine*, 58(8), 511-516.
- Moschandreas, D. J., & Relwani, S. M. (1989). Field-Measurements of NO₂ Gas Range-Top Burner Emission Rates. *Environment International*, 15(1-6), 489-492.
- Moschandreas, D., Relwani, S., Johnson, D., & Billick, I. (1986). Emission Rates from Unvented Gas Appliances. *Environment International*, 12(1-4), 247-254.
- EPA. Fine Particle Designations. Available at <http://www.epa.gov/pmdesignations/faq.htm>. Sourced on December 10, 2014.
- Logue et al. (2012). A method to estimate the chronic health impact of air pollutants in U.S. residences. *Environmental Health Perspectives*: 120(2): 216-222.
- McKenna, M.T., C.M. Michaud, C.J.L. Murray, and J.S. Marks. (2005). Assessing the burden of disease in the United States using disability-adjusted life years. *Am J Prev Med.*: 28(5):415-423.
- Nicole, W. (2014). Cooking Up Indoor Air Pollution: Emissions from Natural Gas Stoves. *Environ Health Perspect*: 122-A27.
- Offerman, F.J. (2009). Ventilation and indoor air quality in new homes. PIER Collaborative Report. California Energy Commission & California Environmental Protection Agency Air Resources Board.
- Klug, V. L., Lobscheid, A. B., & Singer, B. C. (2011). Cooking Appliance Use in California Homes - Data Collected from a Web-Based Survey LBNL-5028E. Berkeley, CA: Lawrence Berkeley National Laboratory.
- Logue et al. (2014). Pollutant exposures from natural gas cooking burners: a simulation based assessment for Southern California." Lawrence Berkeley National Laboratory. LBNL-6712E.
- Smith, P.A. (2013). The Kitchen as a Pollution Hazard. *New York Times*. <http://well.blogs.nytimes.com/2013/07/22/the->

kitchen-as-a-pollution-hazard/?_r=0. Accessed December 10, 2014.

Belanger, K., Gent, J. F., Triche, E. W., Bracken, M. B., & Leaderer, B. P. (2006). Association of indoor nitrogen dioxide exposure with respiratory symptoms in children with asthma. *American Journal of Respiratory and Critical Care Medicine*, 173(3), 297-303. doi: 10.1164/rccm.200408-1123OC.

Hansel, N. N., Breyse, P. N., McCormack, M. C., Matsui, E. C., Curtin-Brosnan, J., Williams, D. L., . . . Diette, G. B. (2008). A longitudinal study of indoor nitrogen dioxide levels and respiratory symptoms in inner-city children with asthma. *Environmental Health Perspectives*, 116(10), 1428-1432. doi:10.1289/ehp.11349.

Garrett, M. H., Hooper, M. A., Hooper, B. M., & Abramson, M. J. (1998). Respiratory symptoms in children and indoor exposure to nitrogen dioxide and gas stoves. *American Journal of Respiratory and Critical Care Medicine*, 158(3), 891-895.

Abdullahi, K. L., Delgado-Saborit, J. M., & Harrison, R. M. (2013). Emissions and indoor concentrations of particulate matter and its specific chemical components from cooking: A review. *Atmospheric Environment*, 71, 260-294. doi: Doi 10.1016/J.Atmosenv.2013.01.061.

Buonanno, G., Morawska, L., & Stabile, L. (2009). Particle emission factors during cooking activities. *Atmospheric Environment*, 43(20), 3235-3242. doi: Doi 10.1016/J.Atmosenv.2009.03.044.

Fortmann, R., Kariher, P., & Clayton, R. (2001). Indoor air quality: residential cooking exposures. Sacramento, CA: Prepared for California Air Resources Board.

Seaman, V. Y., Bennett, D. H., & Cahill, T. M. (2009). Indoor acrolein emission and decay rates resulting from domestic cooking events. *Atmospheric Environment*, 43(39), 6199-6204. doi: 10.1016/j.atmosenv.2009.08.043.

Zhang, Q. F., Gangupomu, R. H., Ramirez, D., & Zhu, Y. F. (2010). Measurement of Ultrafine Particles and Other Air Pollutants Emitted by Cooking Activities. *International Journal of Environmental Research and Public Health*, 7(4), 1744-1759. doi: 10.3390/ijerph7041744.

Cost Impact

The code change proposal will increase the cost of construction .

Where builders are already installing ducts with range hoods, there will not be any increase in the cost of construction. Where new, single-family dwelling units are not currently provided with ducts for their range hoods, this proposal would increase the cost of construction. Installed duct costs can be estimated at ~ \$9.85 per linear foot for 3.25"x10" galvanized sheet metal (RS Means, 2015, Section 23 31 13.13.0500), and a damper would cost about \$15 retail.

Internal ID: 1744

RM13-18

IRC: M1502.3

Proponent: Pennie Feehan, representing Plumbing, Mechanical, and Fuel Gas Code Action Committee (PMGCAC@iccsafe.org)

2018 International Residential Code

Revise as follows:

M1502.3 Duct termination. Exhaust ducts shall terminate on the outside of the building. Exhaust duct terminations shall be in accordance with the dryer manufacturer's installation instructions. If the manufacturer's instructions do not specify a termination location, the exhaust duct shall terminate not less than 3 feet (914 mm) in any direction from openings into buildings including openings in ventilated soffits. Exhaust duct terminations shall be equipped with a backdraft damper. Screens shall not be installed at the duct termination.

Reason:

The code does not address ventilated soffits as building openings, which indeed they are.

This proposal is submitted by the ICC Plumbing/Mechanical/Gas Code Action Committee (PMG CAC). The PMG CAC was established by the ICC Board of Directors to pursue opportunities to improve and enhance the International Codes or portions thereof that were under the purview of the PMG CAC. In 2017 the PMG CAC held one face-to-face meeting and 11 conference call meetings. Numerous interested parties attended the committee meetings and offered their input.

Cost Impact

The code change proposal will not increase or decrease the cost of construction .

This proposal will not increase the cost of construction because no additional labor, materials, equipment, appliances or devices are mandated beyond what is currently required by the code.

Internal ID: 529

RM14-18

IRC: 1502.3.2 (New)

Proponent: Rick Harpenau, representing self (rick@dryerbox.com)

2018 International Residential Code

Add new text as follows:

1502.3.2 Animal Grills. Where grilles are provided on dryer exhaust duct terminals to prevent entry of animals, the grille shall consist entirely of vertical slots without horizontal or diagonal members, the slots shall have a width of not less than 5/8 inch, and the total open area of the grille shall be not less than 4 times the opening area of the exhaust duct.

Reason:

Rural areas across our country experience sufficient intrusion of squirrels, rodents and birds. So much so that homeowners seek or create their own protection. Many resort to mechanical cloth wraps with wire spacing of less than 1/2". Plastic grilles are common as well but due to the lack of material strength, the grill partitions are large and flat promoting accelerated lint build up. Some plastic wall vent hoods incorporate an integral defensive grill. Generally, this design does not provide an adequate area spread and aperture size of each opening is insufficient to allow the lint accumulation to release and exit.

Currently Section 1502.3 clearly indicates screens shall not be installed at the duct termination. Grills and screens could be considered equivalent in description causing confusion. A separate section defining acceptable grills seems logical and removes the equal comparison argument for grills and screens and their use at or near the dryer termination.

Vertical bars resist accelerated lint build up.

The text simply lays out criteria for cages to feature vertical bars.











Bibliography:

Inventor of the Dryerbox. Owner of In-O-Vate Technologies Inc.

Cost Impact

The code change proposal will not increase or decrease the cost of construction .

A rodent/bird defensive grill or cage is an owner/occupant discretionary item.

Wording is necessary to distinguish grills from disallowed screens.

Internal ID: 426

RM15-18

IRC: M1502.4.2

Proponent: Rick Harpenau, representing self (rick@dryerbox.com)

2018 International Residential Code

Revise as follows:

M1502.4.2 Duct installation. Exhaust ducts shall be supported at intervals not to exceed ~~12-4~~ feet (~~3658-1219~~ mm) and shall be secured in place. The insert end of the duct shall extend into the adjoining duct or fitting in the direction of airflow. Exhaust duct joints shall be sealed in accordance with Section M1601.4.1 and shall be mechanically fastened. Ducts shall not be joined with screws or similar fasteners that protrude more than $\frac{1}{8}$ inch (3.2 mm) into the inside of the duct. Where dryer exhaust ducts are enclosed in wall or ceiling cavities, such cavities shall allow the installation of the duct without deformation.

Reason:

12 feet spacing does not provide adequate support for sections of pipe that feature a maximum length of 5 feet. Also, for consistency, the Mechanical Code requires 4 feet support intervals. For the most part, the Res and Mech codes mirror themselves except for the support intervals. These images show the importance of both mechanical fastening, seam taping and 4 foot interval support spacing.



Bibliography:

Inventor of the Dryerbox receptacle, president of In-O-Vate Technologies Inc

Cost Impact

The code change proposal will not increase or decrease the cost of construction .

Clarification and consistency between the Res and Mech codes.

Internal ID: 323

RM16-18

IRC: M1502.4.2

Proponent: Pennie Feehan, representing Plumbing, Mechanical, and Fuel Gas Code Action Committee (PMGCAC@iccsafe.org)

2018 International Residential Code

Revise as follows:

M1502.4.2 Duct installation. Exhaust ducts shall be supported at intervals not to exceed ~~12-4~~ feet (3658 mm) and shall be secured in place. The insert end of the duct shall extend into the adjoining duct or fitting in the direction of airflow. Exhaust duct joints shall be sealed in accordance with Section M1601.4.1 and shall be mechanically fastened. Ducts shall not be joined with screws or similar fasteners that protrude more than $\frac{1}{8}$ inch (3.2 mm) into the inside of the duct. Where dryer exhaust ducts are enclosed in wall or ceiling cavities, such cavities shall allow the installation of the duct without deformation.

Reason:

This proposal will correlate the IRC provision with that of the IMC. 12 foot spacing is not allowed in the IMC and could cause light gage ducts to fail during duct cleaning operations. A 12 foot run of dryer exhaust duct would have one or more joints in it, thus compromising duct integrity where supports are at 12 foot intervals.

This proposal is submitted by the ICC Plumbing/Mechanical/Gas Code Action Committee (PMG CAC). The PMG CAC was established by the ICC Board of Directors to pursue opportunities to improve and enhance the International Codes or portions thereof that were under the purview of the PMG CAC. In 2017 the PMG CAC held one face-to-face meeting and 11 conference call meetings. Numerous interested parties attended the committee meetings and offered their input.

Cost Impact

The code change proposal will increase the cost of construction .

Additional hangars/supports will be required based on shorter intervals.

Internal ID: 482

RM17-18

IRC: M1504.3

Proponent: Mike Moore, representing The Home Ventilating Institute (mmoore@newportventures.net)

2018 International Residential Code

Revise as follows:

M1504.3 Exhaust openings. Air exhaust openings shall terminate as follows:

1. Not less than 3 feet (914 mm) from property lines.
2. Not less than 3 feet (914 mm) from gravity air intake openings, operable windows and doors.
3. Not less than 10 feet (3048 mm) from mechanical air intake openings except where either of the following apply:
 - 3.1. The exhaust opening is located not less than 3 feet (914 mm) above the air intake opening.
 - 3.2. The exhaust opening is part of a factory-built intake/exhaust combination termination fitting installed in accordance with the manufacturer's instructions, and the exhaust air is drawn from a living space.
4. Openings shall comply with Sections R303.5.2 and R303.6.

Reason:

This proposal is very similar to a PMGCAC proposal on the same subject. The only difference is that this proposal does not include the word "approved" in front of "factory-built intake/exhaust termination combination fitting". In some jurisdiction, equipment or products requiring approval will trigger an "alternative means and methods" process to secure a permit. As explained in the reason statement below, these products have been determined to perform well across manufacturers and models. With good performance and insignificant deviation across products, there is no need to further scrutinize these products or delay permits for dwelling units that specify them. This is the position of the Home Ventilating Institute.

The rest of the reason statement echoes that in the PMGCAC proposal:

Intake/exhaust combination terminations are regularly installed with heating and energy recovery ventilators (H/ERVs) used for dwelling units. Their use reduces building penetrations, labor, and associated system costs. By reducing the number of penetrations, air leakage can also be reduced, resulting in space conditioning energy savings. Further, the durability of the structure can be improved through reducing entry pathways for bulk water.

Manufacturer tests conducted by Natural Resources Canada (NRC) have demonstrated that use of intake/exhaust combination terminations results in minimum cross-contamination of airflows (i.e., not exceeding 4%; see NRC report A1-007793¹). These results are aligned with ASHRAE 62.2 approval of such devices which limits cross-contamination to 10%, as verified by the manufacturer. If approved, this proposed modification to the IRC would limit application of intake/exhaust combination terminations to "approved", "factory-built" units. Approval of this proposed modification is expected to result in more affordable and architecturally-flexible terminations.

Note: The IRC defines living space as, "space within a dwelling unit utilized for living, sleeping, eating, cooking, bathing, washing and sanitation purposes". The use of the term "environmental air" was also considered, but was abandoned because "environmental air" can also include exhaust air from parking garages and clothes dryers, which we want to exclude from this exception.

Bibliography:

Bibliography:

Ouazia, B. 2016. Evaluation of a dual hood performance in term of contaminant re-entrainment from exhaust to supply. A1-007793. National Research Council Canada. For a copy of the report, please contact the proponent at the email address provided. Additional reports are available from the proponent upon request.

Cost Impact

The code change proposal will decrease the cost of construction .

This proposal can reduce the number of intake and exhaust penetrations required for a dwelling unit, thereby reducing the cost of construction.

Internal ID: 1899

RM18-18

IRC: M1505.4.1

Proponent: Joseph Hill, representing New York State Department of State, Division of Building Standards and Codes (Joseph.Hill@dos.ny.gov)

2018 International Residential Code

Revise as follows:

M1505.4.1 System design. The whole-house ventilation system shall consist of one or more supply or exhaust fans, or a combination of such, and associated ducts and controls. Local exhaust or supply fans are permitted to serve as a part of such a system. Outdoor air ducts connected to the return side of an air handler shall be considered as providing supply ventilation. Where building infiltration provides all or a portion of the outdoor air intake for whole-house ventilation, such air intake shall be demonstrated by calculations, otherwise, the whole-house ventilation system shall be designed to provide outdoor air intake by means other than building infiltration.

Reason:

The use of exhaust only ventilation has been the subject of intense debate in the industry, whether exhaust only ventilation can effectively exchange indoor air with outdoor air as is the defined purpose of a Whole House Mechanical Ventilation System. In the case of supply air supplied by building infiltration only, it is hard to justify supply air provided by means of building infiltration only, especially at the rates of infiltration which single family dwellings are required to be tested. When a single-family residence is tested at less than 5 Air Changes per hour, at ACH 50, Code Section R303.4 indicates that Mechanical ventilation is required. All climate design zones throughout the United States are required to be tested at 5 or less air changes per hour. It is the learned opinion of many in the building science industry that exhaust only ventilation does not work to provide the fresh air required by code, and additionally, may be the cause of increasing indoor contaminants, rather than alleviating them.

This science is not very complex, by adding an exhaust fan any given dwelling, you effectively decrease the internal pressure. This will cause an increase in infiltration, drawing with it any contaminants held within the building envelope, as well as a very likely increase radon. The following reasoning may illustrate this point and rationalize the need for this modification. The following quotation are in support this statement;

From Green Builder magazine (September 2009): "Because exhaust-only ventilation pulls air through the building envelope, this approach can bring contaminants from the garage, dust from attics, pesticides from the outdoors, mold spores, and even radon into the house."¹

From NSERDA's "Homeowner's Guide to Ventilation": "Exhaust-only ventilation is a good choice for homes that do not have existing ductwork to distribute heated or cooled air. However, if there is radon in the soil around the house, this method can increase indoor radon levels."¹

From Chapter 9 of the Alaska Residential Building Manual: "Exhaust-only ventilation systems, because they depressurize the house, may increase the amount of radon that enters the living space."¹

Section M1507 Mechanical Ventilation was introduced into the 2012 IRC, being a derivation of the requirements of ASHRAE 62.2 -2004 Ventilation and Acceptable Indoor Air Quality In Residential Buildings. There are additional provisions of ASHRAE 62.2 which require the determination of infiltration air, thereby **allowing** (not requiring) a portion of the supply air for the mechanical ventilation systems to be provided by building infiltration. There is no allowance that can be found within 62.2 which allows for 100% of the supply air for mechanical ventilation systems to be provided by building infiltration. The following calculations are present within ASHRAE 62.2 -2016 which require the determination for the allowable amount of building infiltration air which can be utilized by the mechanical ventilation system.

Section 4.1.2 Infiltration Credit states that if a blower door test has been performed, then a credit for estimated infiltration may be taken for non-attached dwelling units using the procedure in Section 4.1.2 (a) ²

4.1.2 (a) Effective Annual Average Infiltration Rate (O inf) shall be calculated using the normalized leakage calculated from measurements of envelope leakage using either ASTM E779, or CGSB 149.10. The authority having jurisdiction may approve other means of calculating effective leakage area (ELA), such as RESNET Mortgage Industry National; Home Energy Systems Standard.²

The procedure described by 62.2-2016 is represented by Equation 4.2 which states;

$$^2 \text{ ELA} = (\text{Lpress} + \text{Ldepress}) / 2$$

The reference, or test pressure = 4 Pa

Where ELA = effective leakage area, ft²

L press= leakage area from pressurization , ft²

L depress= leakage area from depressurization , ft²

2 Normalized Leakage

Normalized Leakage shall be calculated using Equation 4.4

Equation 4.4- $NL = 1000 \times ELA/A_{\text{floor}} \times [H/H_r]^Z$

NL= Normalized Leakage

ELA= effective leakage area, ft²

A floor= Floor area of Residence

H= Vertical Distance between the lowest and highest above grade points within the pressure boundary, in feet.

H_r= Reference height, 8.2 feet

Z= 0.4

2 The Effective Annual Average Infiltration Rate (Q inf)

The Effective annual average infiltration rate (Q inf) shall be calculated using Equation 4.5a (or 4.5b)

Equation 4.5a - $Q_{\text{inf}} (\text{cfm}) = NL \times WSF \times A_{\text{floor}}/7.3$

NL= Normalized Leakage

WSF= Weather shielding Factor (Normative Appendix B)

A floor= Floor area of Residence

[1]Sources taken from the Green Building Advisor. <http://www.greenbuildingadvisor.com/blogs/dept/musings/exhaust-only-ventilation-systems-and-radon#ixzz53nGgGB6N>

[2] Code Sections and Calculations taken from ASHRAE 62.2 -2016 Ventilation and Acceptable Indoor Air Quality In Residential Buildings.

Bibliography:

Cost Impact

The code change proposal will increase the cost of construction .

The Code change may require the addition of ducts and mechanical and/or gravity damper's.

Internal ID: 1845

RM19-18

IRC: M1505.4.4

Proponent: Anthony Floyd, City of Scottsdale, representing City of Scottsdale (afloyd@scottsdaleaz.gov)

2018 International Residential Code

Revise as follows:

M1505.4.4 Local exhaust rates. *Local exhaust* systems shall be designed to have the capacity to exhaust the minimum airflow rate determined in accordance with Table M1505.4.4. Intermittently operated exhaust fans in bathrooms and toilet rooms shall be provided with a delay-shutoff timer or humidity sensor control.

Exception: A delay-shutoff timer or humidity sensor control switch is not required for exhaust fans that function as a component of a programmed whole-house ventilation system.

Reason:

This code change provides compliance options for intermittently operated exhaust fans when the bathroom is occupied (manual or humidity sensor activation) and for a limited period of time after the user leaves the room (delay timer or humidity sensor deactivation). Delay timer and humidity sensor exhaust fan controls are a consistent and effective means of removing indoor moisture and pollutants.

During a bath or shower, the humidity level in a bathroom can be a perfect breeding ground for mold, mildew and microorganisms that can negatively impact occupant health. Excess moisture has tremendous potential for damaging the structure. It cracks and peels paint, ruins gypsum wallboard, causes exterior paint failure, warps doors and rusts cabinets and fixtures. It can cause deterioration of joists and framing. As it condenses on windows, walls, ceilings and cabinets, it attracts dirt. It encourages mildew on tile grout and generally provides an environment for increased bacterial growth.

According to the Home Ventilation Institute, an intermittently operated exhaust fan needs to run at least 20 minutes after each shower to sufficiently remove moisture from an average size bathroom. Bathroom exhaust systems reduce the risk of mildew and mold growth, which is a sanitation and durability concern in all homes, regardless of climate. Delay timer and moisture sensor controlled exhaust fans are more effective than a manually operated fan or an operable window that is usually left closed during the winter and summer months of the year.

Automatic shut-off controls help to ensure exhaust fan operates when the bathroom is in use and for a limited period of time after the user leaves the room. Automatic controls also save energy by ensuring fans don't run unnecessarily after removal of moisture and pollutants.

Bibliography:

ASHRAE 62.2-2016 Ventilation and Acceptable Indoor Air Quality in Low-Rise Residential Buildings
Home Ventilating Institute - <http://www.hvi.org/publications/HowMuchVent.cfm>

Cost Impact

The code change proposal will increase the cost of construction .

A basic dial delay timer switch costs \$15, while a basic humidity sensor switch costs \$46. Timer and moisture controlled exhaust fans reduce the potential of making costly moisture damage repairs to correct problems that is easy to avoid with adequate local exhaust.

Internal ID: 550

RM20-18

IRC: SECTION M1505, 1505.5 (New)

Proponent: Craig Conner, representing self (craig.conner@mac.com)

2018 International Residential Code

SECTION M1505 MECHANICAL VENTILATION

Add new text as follows:

1505.5 Combustion venting into conditioned space. Permanently installed combustion devices that are designed to vent combustion products into conditioned space shall be approved by a licensed design professional.

Exception: Section 1505.5 shall not apply to stoves, ovens and pilot lights.

Reason:

Combustion devices which are designed to vent combustion products into the conditioned space are high risk from the perspective of indoor air quality. These devices also increase interior moisture and can add contaminants such as NO_x (nitrous oxides).

Cost Impact

The code change proposal will increase the cost of construction .

There will likely be a cost associated with the review by a licensed design professional. However, it is also possible that the design professional will be less expensive than correcting any problem resulting from routinely venting combustion products into conditioned space.

Internal ID: 2010

RM21-18

IRC: M1505.4.3

Proponent: Craig Conner, representing self (craig.conner@mac.com); Joseph Lstiburek, representing Self (joe@buildingscience.com)

2018 International Residential Code

Revise as follows:

M1505.4.3 Mechanical ventilation rate. The whole house mechanical ventilation system shall ~~provide~~be capable of providing outdoor air at a minimum continuous rate as determined in accordance with Table M1505.4.3(1) or Equation 15-1.

~~Ventilation rate in cubic feet per minute = $0.01 \times \text{total square foot area of house} + 7.5 \times \text{number of bedrooms} + 1$~~
Ventilation rate in cubic feet per minute = $(0.01 \times \text{total square foot area of house}) + [7.5 \times (\text{number of bedrooms} + 1)]$ **(Equation 15-1)**

Exception: The whole-house mechanical ventilation system is permitted to operate intermittently where the system has controls that enable operation for not less than 25 percent of each 4-hour segment and the ventilation rate prescribed in Table M1505.4.3(1) or in accordance with Equation 15-1 is multiplied by the factor determined in accordance with Table M1505.4.3(2).

Reason:

This code change contains a number of improvements that clarify the intent and requirements of whole-house mechanical ventilation rates.

First, the ventilation system must “be capable of providing” the necessary ventilation air. A “manual override” (on/off switch) must be provided as defined in M1505.4.2. So, as written, if the system is switched off, the house would be out of code compliance.

Second, the ventilation rates are minimum values and it should be clearly stated in the code.

Third, the term “total square foot area of house” is not a defined term and could easily be interpreted to include unconditioned spaces (e.g. basements, garages, enclosed porches). “conditioned floor area” is a defined term and is appropriate for determining ventilation rates.

Last, Exception 1 intermittent ventilation rates should be able to be determined by either the table or the equation. Last code cycle the equation (15-1) was added to determine the ventilation rate, but was missed in the exception. This change fixes this omission.

Cost Impact

The code change proposal will not increase or decrease the cost of construction .

This change will clarify the code language as described in the "reason".

Internal ID: 1628

RM22-18

IRC: 202 (New), M1505.4.3

Proponent: Craig Conner, representing self (craig.conner@mac.com); Joseph Lstiburek, representing Self (joe@buildingscience.com)

2018 International Residential Code

BALANCED VENTILATION. Any combination of concurrently operating mechanical exhaust and mechanical supply whereby the total mechanical exhaust airflow rate and the total mechanical supply airflow rate are substantially the same.

Revise as follows:

M1505.4.3 Mechanical ventilation rate. The whole house mechanical ventilation system shall provide outdoor air at a continuous rate as determined in accordance with Table M1505.4.3(1) or Equation 15-1.

Ventilation rate in cubic feet per minute = $(0.01 \times \text{total square foot area of house}) + [7.5 \times (\text{number of bedrooms} + 1)]$

(Equation 15-1)

Exception-Exceptions:

1. The whole-house mechanical ventilation system is permitted to operate intermittently where the system has controls that enable operation for not less than 25 percent of each 4-hour segment and the ventilation rate prescribed in Table M1505.4.3(1) is multiplied by the factor determined in accordance with Table M1505.4.3(2).
2. The minimum mechanical ventilation rate determined in accordance with Table M1505.4.3(1) or Equation 15-1 shall be reduced by 25%, provided that all of the following conditions apply:
 - 2.1. A ducted system supplies recirculated air directly to each bedroom and the largest common area.
 - 2.2. For continuously operating systems, not less than 70% of the air volume in the conditioned space is recirculated each hour through a ducted system, or for intermittently operating systems, an equivalent air recirculation is provided during each four hour period.
 - 2.3. The whole-house ventilation system is a balanced ventilation system.

Reason:

This code change credits the better performance of whole-building dilution ventilation systems that are distributed, mixed and balanced.

Distributed, mixed and balanced ventilation is more effective at controlling indoor contaminants than typical exhaust ventilation that provides no distribution and mixing. Ventilation with effective distribution and mixing prevents or minimizes high levels of contaminant concentration in various spaces within houses, especially rooms where people spend a lot of time with doors closed such as bedrooms. Distribution and mixing homogenizes interior conditions reducing potentially harmful high intermittent contaminant concentrations in interior spaces. Complex field testing and contaminate transport software analysis have shown that 70% mixing combined with a 25% reduced balanced ventilation is equally as effective as a typical exhaust ventilation.

This code change does not penalize exhaust ventilation, it justifiably credits balanced ventilation. Exhaust only ventilation should not be given the same indoor air quality credit in energy rating calculations since typical exhaust ventilation systems result in less air change than balanced ventilation systems and do not provide as effective control of contaminants. This code change rectifies that inequity.

Technical justification for this proposed code change can be found in the following links:

https://buildingscience.com/sites/default/files/migrate/pdf/CP-0909_ASHRAE_Calibrated_Multizone_Airflow.pdf

https://buildingscience.com/sites/default/files/migrate/pdf/CP-0908_ASHRAE_Modifying_Ventilation_Airflow.pdf

https://buildingscience.com/sites/default/files/migrate/pdf/CP-0802_Field_Test_Room_to_Room.pdf

<http://www.nrcan.gc.ca/energy/efficiency/housing/home-improvements/18633>

https://www.nrc-cnrc.gc.ca/ctu-sc/files/doc/ctu-sc/ctu-n15_eng.pdf

Cost Impact

The code change proposal will decrease the cost of construction .

Choosing to use a more effective type of ventilation will result in a lower ventilation rate which could reduce both construction and operating costs.

Internal ID: 1631

RM23-18

IRC: TABLE M1505.4.4

Proponent: Mike Moore, representing Broan-NuTone (mmoore@newportventures.net)

2018 International Residential Code

Revise as follows:

TABLE M1505.4.4
MINIMUM REQUIRED LOCAL EXHAUST RATES FOR ONE- AND TWO-FAMILY DWELLINGS

AREA TO BE EXHAUSTED	EXHAUST RATES ^a
Kitchens	100 cfm intermittent or 25 cfm continuous
Bathrooms-Toilet Rooms	Mechanical exhaust capacity of 50 cfm intermittent or 20 cfm continuous

For SI: 1 cubic foot per minute = 0.0004719 m³/s.

a. The listed exhaust rate for bathrooms-toilet rooms shall equal or exceed the exhaust rate at a minimum static pressure of 0.25 inch wc in accordance with Section M1505.3.

Reason:

To ensure that exhaust fans provide the minimum CFM required by the IRC, the IRC was amended in recent cycles to require prescriptive duct sizing for exhaust rates taken at a static pressure of 0.25 inch water column (see Table M1504.2). For consistency, this change will align the flow rate requirements of Table 1505.4.4 with the duct sizing requirements of Table M1504.2 and the equipment listing requirements of Section M1505.3.

Cost Impact

The code change proposal will not increase or decrease the cost of construction .

The prescriptive duct sizing requirements of M1504.2 require that ducts be sized for flows taken at 0.25 in w.c. in accordance with ANSI/AMCA 210-ANSI/ASHRAE 51. Because this change is a simple clarification of existing requirements, no change to construction cost is expected.

Internal ID: 1761

RM24-18

IRC: 202 (New), M1505.1, M1505.4.3

Proponent: Mike Moore, representing The Home Ventilating Institute (mmoore@newportventures.net)

2018 International Residential Code

Add new text as follows:

BALANCED VENTILATION SYSTEM. A ventilation system where the total supply airflow and total exhaust airflow are simultaneously within 10% of their average. The balanced ventilation system airflow is the average of the supply and exhaust airflows.

Revise as follows:

M1505.1 General. Where local exhaust or whole-house mechanical ventilation is provided, the ~~equipment-ventilation system~~ shall be designed in accordance with this section.

M1505.4.3 Mechanical ventilation rate. The whole house mechanical ventilation system shall provide outdoor air at a continuous rate ~~as not less than that~~ determined in accordance with Table M1505.4.3(1) or ~~not less than that~~ determined by Equation 15-1.

Ventilation rate in cubic feet per minute = $(0.01 \times \text{total square foot area of house}) + [7.5 \times (\text{number of bedrooms} + 1)]$

(Equation 15-1)

Exceptions:

1. Ventilation rate credit. Where a whole-house mechanical balanced ventilation system is provided, the whole-house mechanical ventilation system rate shall be permitted to be adjusted by multiplying the ventilation rate determined in accordance with Table M1505.4.3(1) or by Equation 15-1 by 0.7.
2. Programmed intermittent operation. The whole-house mechanical ventilation system is permitted to operate intermittently where the system has controls that enable operation for not less than 25 percent of each 4-hour segment and the ventilation rate prescribed in Table M1505.4.3(1), by Equation 15-1, or by Exception 1 is multiplied by the factor determined in accordance with Table M1505.4.3(2).

Reason:

This proposal is very similar to a PMGCAC proposal that also proposes a ventilation rate credit for balanced systems. The only difference between the proposals is that this proposal does not reference ASHRAE 62.2 as an optional path.

Balanced mechanical ventilation systems provide superior ventilation to unbalanced systems, and should not be required to provide the same rate as less effective, unbalanced systems to provide equivalent ventilation. This proposed credit for balanced ventilation is a simplified version that was derived from ASHRAE 62.2-2016 Equation 4.2 (published in addendum s). The ASHRAE equation adjusts the balanced whole house ventilation flow rate as a function of building air leakage, building height, and weather and shielding factor (which approximates climate zone). To simplify application of the ASHRAE calculation, we developed a one-size-fits-all balanced system factor using the following methodology:

1. Define a typical new, single-family detached home. The home characteristics were as follows: 2600 ft²; 3-bedroom; heights of 8, 17, and 26 feet above grade for one-, two- and three-story versions of the typical home; and leakage rate of 4.5 ACH50 in CZ 1-2 and 2.5 ACH50 in CZ 3-8. Note: Higher values for air leakage provide larger credits for balanced ventilation systems. To be conservative, we assumed that the average home was slightly tighter than the 2018 IECC maximum leakage rates of 5 ACH50 in CZ 1-2 and 3 ACH50 in CZ 3-8 (i.e., 4.5 ACH50 instead of 5 ACH50 in CZ 1-2 and 2.5 ACH50 instead of 3 ACH50 in CZ 3-8).

2. Calculate the average weather and shielding factor across each climate zone using over 1000 weather stations catalogued in Appendix B of ASHRAE 62.2.

3. Calculate the ASHRAE 62.2-2016 flow rates for balanced and unbalanced systems in the one-, two-, and three-story versions of the typical home across all IECC climate zones using Equation 4.2 and the average weather and shielding factors calculated in step 2.

4. Calculate the percent reduction in the balanced system ventilation rate versus the unbalanced systems' ventilation rate for each case. Apply weightings to the percent reductions for one-, two-, and three-story cases in each climate zone based on average U.S. Census Data (i.e., 44% are assumed to be one-story; 52% are assumed to be two-story; 4% are assumed to be 3-story in each climate zone). Sum the weighted percent reductions for the various stories to develop an estimated percent reduction for each climate zone.

Following is a table that summarizes interim and aggregate results of these steps used to calculate the balanced ventilation system multiplier of 0.7. The weighted average percent reduction in flow rate for balanced systems across each climate zone varied from 22% to 41%. The average percent reduction in flow rate for balanced systems across all scenarios for the typical home is ~30%, resulting in a multiplier of 0.7 in this proposal.

Percent Reduction Possible in Ventilation Fan Flow Rate When Specifying Balanced vs. Unbalanced: 4.5 ACH50 in CZ 1-2 & 2.5 ACH50 in CZ 3-8				
CZ	Stories and Distribution			Weighted Average Across All Stories
	44% 1-story	52% 2-story	4% 3-story	
1A	31%	42%	50%	38%
2A	30%	41%	49%	37%
2B	34%	46%	55%	41%
3A	18%	25%	29%	22%
3B	20%	27%	32%	24%
3C	21%	28%	34%	25%
4A	20%	27%	32%	24%
4B	24%	33%	39%	29%
4C	23%	31%	36%	27%
5A	23%	31%	37%	28%
5B	24%	33%	39%	29%
6A	25%	34%	40%	30%
6B	27%	37%	44%	33%
7	29%	39%	46%	35%
8	34%	46%	54%	41%
Average of weighted averages				31%

Cost Impact

The code change proposal will decrease the cost of construction .

This proposal may decrease the cost of construction by approving specification of balanced systems with lower flow rates.

Internal ID: 595

RM25-18

IRC: M1505.1, 44

Proponent: Mike Moore, representing The Home Ventilating Institute (mmoore@newportventures.net)

2018 International Residential Code

Revise as follows:

M1505.1 General. Where local exhaust or whole-house mechanical ventilation is provided, the equipment-ventilation system shall be designed in accordance with this section, or the ventilation system shall be designed in accordance with ASHRAE 62.2.

Add new standard(s) follows:

ASHRAE

ASHRAE
1791 Tullie Circle NE
Atlanta GA 30329
US

62.2-2016:

Ventilation and Acceptable Indoor Air Quality in Residential Buildings with Addenda b, d, k, l, q, and s.

Reason:

This proposed modification would provide builders with the OPTION of using ASHRAE Standard 62.2 to comply with the ventilation requirements of the IRC without requiring builders to use the standard. ASHRAE 62.2 is the ANSI standard for establishing minimum acceptable indoor air quality for dwelling units. There are several reasons that builders may want to use ASHRAE 62.2 instead of the IRC for compliance, including: greater flexibility for specifying climate-appropriate ventilation controls, ability to achieve energy and cost savings for homeowners by shifting operation of the ventilation system to times when ambient temperature and humidity are favorable, flexibility to specify innovative systems that can be demonstrated to provide equivalent exposure to pollutants, ability to down-size and save money on balanced ventilation equipment versus what may be required by the code, 62.2's use by code-plus programs such as ENERGY STAR and LEED, and ability to size the system as a function of measured dwelling unit air leakage instead of a one-size-fits-all approach.

Cost Impact

The code change proposal will not increase or decrease the cost of construction .

Use of this standard is proposed as an OPTIONAL path. Costs associated with using 62.2 versus other compliance paths will vary based on the application. As such, this proposal will neither decrease nor increase the cost of construction.

Internal ID: 533

RM26-18

IMC: 202 (New); IRC: M1505.1, M1505.4.3, ordinal

Proponent: Pennie Feehan, representing Plumbing, Mechanical, and Fuel Gas Code Action Committee (PMGCAC@iccsafe.org)

2018 International Mechanical Code

Add new definition as follows:

BALANCED VENTILATION SYSTEM. A ventilation system where the total supply fan airflow is within 20 percent of the total exhaust fan airflow. The balanced system airflow is the average of the supply and exhaust airflows.

2018 International Residential Code

Revise as follows:

M1505.1 General. Where local exhaust or whole-house mechanical ventilation is provided, the ~~equipment ventilation system~~ shall be designed in accordance with this ~~section~~ section, or the ventilation system shall be designed in accordance with ASHRAE 62.2.

M1505.4.3 Mechanical ventilation rate. The whole house mechanical ventilation system shall provide outdoor air at a continuous rate ~~as not less than that~~ determined in accordance with Table M1505.4.3(1) or ~~not less than that~~ determined by Equation 15-1.

Ventilation rate in cubic feet per minute = $(0.01 \times \text{total square foot area of house}) + [7.5 \times (\text{number of bedrooms} + 1)]$

(Equation 15-1)

~~Exception:~~Exceptions:

1. Ventilation rate credit. Where a balanced whole-house mechanical ventilation system is provided, the whole-house mechanical ventilation system rate shall be permitted to be adjusted by multiplying the mechanical ventilation rate determined in accordance with Table M1505.4.3(1) or by Equation 15-1 by 0.7.
2. Programmed intermittent operation. The whole-house mechanical ventilation system is permitted to operate intermittently where the system has controls that enable operation for not less than 25 percent of each 4-hour segment and the ventilation rate prescribed in Table M1505.4.3(1) , by Equation 15-1, or by Exception 1 is multiplied by the factor determined in accordance with Table M1505.4.3(2).

Add new standard(s) follows:

ASHRAE

ASHRE
1791 Tullie Circle NE
Atlanta GA 30329
US

62.2-2016:

Ventilation and Acceptable Indoor Air Quality in Residential Buildings with Addenda b, d, k, l, g, and s

Reason:

Balanced mechanical ventilation systems provide superior ventilation to unbalanced systems, and should not be required to provide the same rate as less effective, unbalanced systems to provide equivalent ventilation. This proposed credit for balanced ventilation is a simplified version that was derived from ASHRAE 62.2-2016 Equation 4.2 (published in addendum s). The ASHRAE equation adjusts the balanced whole house ventilation flow rate as a function of building air leakage, building height, and weather and shielding factor (which approximates climate zone). To simplify application of the ASHRAE calculation for the IRC, we developed a one-size-fits-all balanced system factor using the following methodology:

1. Define a typical new, single-family detached home. The home characteristics were as follows: 2600 ft²; 3-bedroom; heights of 8, 17, and 26 feet above grade for one-, two- and three-story versions of the typical home; and leakage rate of 4.5 ACH50 in CZ 1-2 and 2.5 ACH50 in CZ 3-8. Note: Higher values for air leakage provide larger credits for balanced ventilation systems. To be conservative, we assumed that the average home was slightly tighter than the 2018 IECC

maximum leakage rates of 5 ACH50 in CZ 1-2 and 3 ACH50 in CZ 3-8 (i.e., 4.5 ACH50 instead of 5 ACH50 in CZ 1-2 and 2.5 ACH50 instead of 3 ACH50 in CZ 3-8).

2. Calculate the average weather and shielding factor across each climate zone using over 1000 weather stations catalogued in Appendix B of ASHRAE 62.2.
3. Calculate the ASHRAE 62.2-2016 flow rates for balanced and unbalanced systems in the one-, two-, and three-story versions of the typical home across all IECC climate zones using Equation 4.2 and the average weather and shielding factors calculated in step 2.
4. Calculate the percent reduction in the balanced system ventilation rate versus the unbalanced systems' ventilation rate for each case. Apply weightings to the percent reductions for one-, two-, and three-story cases in each climate zone based on average U.S. Census Data (i.e., 44% are assumed to be one-story; 52% are assumed to be two-story; 4% are assumed to be 3-story in each climate zone). Sum the weighted percent reductions for the various stories to develop an estimated percent reduction for each climate zone.

Following is a table that summarizes interim and aggregate results of these steps used to calculate the balanced ventilation system flow rate multiplier of 0.7. The weighted average percent reduction in flow rate for balanced systems across each climate zone varied from 22% to 41%. The average percent reduction in flow rate for balanced systems across all scenarios for the typical home is ~30%, resulting in a multiplier of 0.7 in this proposal.

This proposal is submitted by the ICC Plumbing/Mechanical/Gas Code Action Committee (PMG CAC). The PMG CAC was established by the ICC Board of Directors to pursue opportunities to improve and enhance the International Codes or portions thereof that were under the purview of the PMG CAC. In 2017 the PMG CAC held one face-to-face meeting and 11 conference call meetings. Numerous interested parties attended the committee meetings and offered their input.

Cost Impact

The code change proposal will not increase or decrease the cost of construction .

This proposal will not increase the cost of construction because no additional labor, materials, equipment, appliances or devices are mandated beyond what is currently required by the code.

Percent Reduction Possible in Ventilation Fan Flow Rate When Specifying Balanced vs. Unbalanced: 4.5 ACH50 in CZ 1-2 & 2.5 ACH50 in CZ 3-8				
CZ	Stories and Distribution			Weighted Average Across All Stories
	44%	52%	4%	
	1-story	2-story	3-story	
1A	31%	42%	50%	38%
2A	30%	41%	49%	37%
2B	34%	46%	55%	41%
3A	18%	25%	29%	22%
3B	20%	27%	32%	24%
3C	21%	28%	34%	25%
4A	20%	27%	32%	24%
4B	24%	33%	39%	29%
4C	23%	31%	36%	27%
5A	23%	31%	37%	28%
5B	24%	33%	39%	29%
6A	25%	34%	40%	30%
6B	27%	37%	44%	33%
7	29%	39%	46%	35%
8	34%	46%	54%	41%
Average of weighted averages				31%

Analysis: A review of the standard proposed for inclusion in the code, with regard to the ICC criteria for referenced standards (Section 3.6 of CP#28) will be posted on the ICC website on or before April 2, 2018.

Internal ID: 569

RM27-18

IRC: M1504.3

Proponent: Pennie Feehan, representing Plumbing, Mechanical, and Fuel Gas Code Action Committee (PMGCAC@iccsafe.org)

2018 International Residential Code

Revise as follows:

M1504.3 Exhaust openings. Air exhaust openings shall terminate as follows:

1. Not less than 3 feet (914 mm) from property lines.
2. Not less than 3 feet (914 mm) from gravity air intake openings, operable windows and doors.
3. Not less than 10 feet (3048 mm) from mechanical air intake openings except where either of the following apply:
 - 3.1. the exhaust opening is located not less than 3 feet (914 mm) above the air intake opening.
 - 3.2. The exhaust opening is part of an approved factory-built intake/exhaust combination termination fitting installed in accordance with the manufacturer's instructions, and the exhaust air is drawn from a living space.
4. Openings shall comply with Sections R303.5.2 and R303.6.

Reason:

Intake/exhaust combination terminations are regularly installed with heating and energy recovery ventilators (H/ERVs) used for dwelling units. Their use reduces building penetrations, labor, and associated system costs. By reducing the number of penetrations, air leakage can also be reduced, resulting in space conditioning energy savings. Further, the durability of the structure can be improved through reducing entry pathways for bulk water.

Manufacturer tests conducted by Natural Resources Canada (NRC) have demonstrated that use of intake/exhaust combination terminations results in minimum cross-contamination of airflows (i.e., not exceeding 4%; see NRC report A1-007793¹). These results are aligned with ASHRAE 62.2 approval of such devices, which limits cross-contamination to 10%, as verified by the manufacturer. If approved, this proposed modification to the IRC would limit application of intake/exhaust combination terminations to “approved”, “factory-built” units. Approval of this proposed modification is expected to result in more affordable and architecturally flexible terminations.

Note: The IRC defines living space as, “space within a dwelling unit utilized for living, sleeping, eating, cooking, bathing, washing and sanitation purposes”.

This proposal is submitted by the ICC Plumbing/Mechanical/Gas Code Action Committee (PMG CAC). The PMG CAC was established by the ICC Board of Directors to pursue opportunities to improve and enhance the International Codes or portions thereof that were under the purview of the PMG CAC. In 2017 the PMG CAC held one face-to-face meeting and 11 conference call meetings. Numerous interested parties attended the committee meetings and offered their input.

Bibliography:

Ouazia, B. 2016. Evaluation of a dual hood performance in term of contaminant re-entrainment from exhaust to supply. A1-007793. National Research Council Canada. For a copy of the report, please contact the proponent at the email address provided. Additional reports are available from the proponent upon request.

Cost Impact

The code change proposal will not increase or decrease the cost of construction .

This proposal will not increase the cost of construction because no additional labor, materials, equipment, appliances or devices are mandated beyond what is currently required by the code.

Internal ID: 567

RM28-18

IRC: M1503.4

Proponent: Pennie Feehan, representing Plumbing, Mechanical, and Fuel Gas Code Action Committee (PMGCAC@iccsafe.org)

2018 International Residential Code

Revise as follows:

M1503.4 Duct material. Ducts serving domestic cooking exhaust equipment shall be constructed of ~~galvanized steel, stainless steel or copper,~~ smooth-wall metal of thicknesses consistent with Table M1601.1.1.

Exception: Ducts for domestic kitchen cooking *appliances* equipped with down-draft exhaust systems shall be permitted to be constructed of schedule 40 PVC pipe and fittings provided that the installation complies with all of the following:

1. The duct is installed under a concrete slab poured on grade.
2. The underfloor trench in which the duct is installed is completely backfilled with sand or gravel.
3. The PVC duct extends not more than 1 inch (25 mm) above the indoor concrete floor surface.
4. The PVC duct extends not more than 1 inch (25 mm) above grade *outside of the building*.
5. The PVC ducts are solvent cemented.

Reason:

There is no reason why black steel and aluminum ducts can't be used. It is important that the ducts be metal and smooth-wall. A reference to the duct wall thickness table was missing.

This proposal is submitted by the ICC Plumbing/Mechanical/Gas Code Action Committee (PMG CAC). The PMG CAC was established by the ICC Board of Directors to pursue opportunities to improve and enhance the International Codes or portions thereof that were under the purview of the PMG CAC. In 2017 the PMG CAC held one face-to-face meeting and 11 conference call meetings. Numerous interested parties attended the committee meetings and offered their input.

Cost Impact

The code change proposal will not increase or decrease the cost of construction .

This proposal will not increase the cost of construction because no additional labor, materials, equipment, appliances or devices are mandated beyond what is currently required by the code.

Internal ID: 485

RM29-18

IRC: M1505.4.2

Proponent: Pennie Feehan, representing Plumbing, Mechanical, and Fuel Gas Code Action Committee (PMGCAC@iccsafe.org)

2018 International Residential Code

Revise as follows:

M1505.4.2 System controls. The whole-house mechanical ventilation system shall be provided with controls that enable manual override. Controls shall include text or a symbol indicating their function.

Reason:

Tight dwelling units are being outfitted with code-mandated outdoor air/"whole-house" mechanical ventilation systems. These systems are often simply a bathroom exhaust fan expected to run continuously. The problem is that without a label indicating the system's function, occupants have no idea of the purpose of these systems and are likely to turn them off - thereby increasing the rate of accumulation of harmful indoor pollutants without their knowledge. At a minimum, these systems should be labeled to indicate that they are different than a typical bath fan. This proposed language would echo language in ASHRAE 62.2 and also within the 2018 IMC as follows: "403.3.2.4 System controls. Where provided within a dwelling unit, controls for outdoor air ventilation systems shall include text or a symbol indicating the system's function." The language is intended to be flexible enough to allow multiple options for the text or symbol, provided it achieves the intention of conveying that the control is for a system that is not merely a standard bath fan. For example, the Home Ventilating Institute (an industry association representing over 90% of the manufacturers of residential ventilating products in the U.S.), recently developed the following logo for this purpose:



This proposal is submitted by the ICC Plumbing/Mechanical/Gas Code Action Committee (PMG CAC). The PMG CAC was established by the ICC Board of Directors to pursue opportunities to improve and enhance the International Codes or portions thereof that were under the purview of the PMG CAC. In 2017 the PMG CAC held one face-to-face meeting and 11 conference call meetings. Numerous interested parties attended the committee meetings and offered their input.

Cost Impact

The code change proposal will increase the cost of construction .

This proposal will increase the cost of construction because a label will be required on a switch cover.

Internal ID: 563

RM30-18

IRC: M1505.3

Proponent: Pennie Feehan, representing Plumbing, Mechanical, and Fuel Gas Code Action Committee (PMGCAC@iccsafe.org)

2018 International Residential Code

Revise as follows:

M1505.3 Exhaust equipment. Exhaust equipment serving single dwelling units fans and whole-house mechanical ventilation fans shall be *listed* and *labeled* as providing the minimum required airflow in accordance with ANSI/AMCA 210-ANSI/ASHRAE 51.

Reason:

Industry experience and research have shown that "for advertised airflows that are not certified, the actual installed airflow can be a small fraction of the advertised value".¹ The 2018 IMC and IRC now require listing and labeling flows in accordance with ANSI/AMCA 210-ANSI/ASHRAE 51 for exhaust equipment serving single dwelling units. This requirement should be expanded to all fans under the scope of the ANSI standard to ensure that flows are reported on an equivalent basis. AMCA and HVI maintain listings of products tested in accordance with the standard.

This proposal is submitted by the ICC Plumbing/Mechanical/Gas Code Action Committee (PMG CAC). The PMG CAC was established by the ICC Board of Directors to pursue opportunities to improve and enhance the International Codes or portions thereof that were under the purview of the PMG CAC. In 2017 the PMG CAC held one face-to-face meeting and 11 conference call meetings. Numerous interested parties attended the committee meetings and offered their input.

Bibliography:

1. Singer, B. C., Delp, W. W., Apte, M., & Price, P. N. (2011). Performance of Installed Cooking Exhaust Devices. LBNL-5265E. Berkeley, CA: Lawrence Berkeley National Laboratory.

Cost Impact

The code change proposal will not increase or decrease the cost of construction .

This proposal will not increase the cost of construction because no additional labor, materials, equipment, appliances or devices are mandated beyond what is currently required by the code.

Internal ID: 568

RM31-18

IRC: M1601.1.1

Proponent: David Bixby, Air Conditioning Contractors of America (ACCA), representing Air Conditioning Contractors of America (bixster1953@yahoo.com)

2018 International Residential Code

Revise as follows:

M1601.1.1 Above-ground duct systems. Above-ground *duct systems* shall conform to the following:

1. *Equipment* connected to *duct systems* shall be designed to limit discharge air temperature to not greater than 250°F (121°C).
2. Factory-made ducts shall be listed and labeled in accordance with UL 181 and installed in accordance with the manufacturer's instructions.
3. Fibrous glass duct construction shall conform to the SMACNA *Fibrous Glass Duct Construction Standards* or NAIMA *Fibrous Glass Duct Construction Standards*.
4. Field-fabricated and shop-fabricated metal and flexible duct constructions shall conform to the SMACNA *HVAC Duct Construction Standards—Metal and Flexible* except as allowed by Table M1601.1.1. Galvanized steel shall conform to ASTM A653.
5. The use of gypsum products to construct return air ducts or plenums is permitted, provided that the air temperature does not exceed 125°F (52°C) and exposed surfaces are not subject to condensation.
6. *Duct systems* shall be constructed of materials having a flame spread index of not greater than 200.
7. Stud wall cavities and the spaces between solid floor joists to be used as air plenums shall comply with the following conditions:
 - 7.1. These cavities or spaces shall not be used as a plenum for supply air.
 - 7.2. These cavities or spaces shall not be part of a required fire-resistance-rated assembly.
 - 7.3. Stud wall cavities shall not convey air from more than one floor level.
 - 7.4. Stud wall cavities and joist-space plenums shall be isolated from adjacent concealed spaces by tight-fitting fireblocking in accordance with Section R602.8.
 - 7.5. Stud wall cavities in the outside walls of building envelope assemblies shall not be utilized as air plenums.
8. Volume dampers, equipment and other means of supply, return and exhaust air adjustment used in system balancing shall be provided with access.
9. Zoned duct systems shall be designed and installed in accordance with ACCA Manual Zr.

Reason:

Currently there is no coverage in the residential code to address the design of zoned duct systems. ACCA Manual Zr provides procedures for designing zoned comfort systems for single family detached homes, duplex and triplex homes, row houses, town houses, and large multi-family structures that are compatible with ACCA Manual J procedures for residential load calculations. In addition, use of Manual Zr will avoid the potential for an improperly designed zoned duct system to adversely impact the safe operation and durability of the heating/cooling equipment. For code officials, Manual Zr has three normative sections to determine clear compliance. Manual Zr is also a consensus-based ANSI standard.

Cost Impact

The code change proposal will not increase or decrease the cost of construction .

Cost impacts for using Manual Zr would be minimal, other than some extra time involved. Installers will have to ensure the installation of equipment and zoning devices complies with OEM installation instructions, as well as documenting such. Code officials will have to verify and document airflow rates, set-points for operation and safety controls, which will involve minimal time.

Analysis: A review of the standard proposed for inclusion in the code, with regard to the ICC criteria for referenced

standards (Section 3.6 of CP#28) will be posted on the ICC website on or before April 2, 2018.

Internal ID: 1860

RM32-18

IRC: M1601.1.1, M1601.4.5

Proponent: Pennie Feehan, representing Plumbing, Mechanical, and Fuel Gas Code Action Committee (PMGCAC@iccsafe.org)

2018 International Residential Code

Revise as follows:

M1601.1.1 Above-ground duct systems. Above-ground *duct systems* shall conform to the following:

1. *Equipment* connected to *duct systems* shall be designed to limit discharge air temperature to not greater than 250°F (121°C).
2. Factory-made ducts shall be listed and labeled in accordance with UL 181 and installed in accordance with the manufacturer's instructions.
3. Fibrous glass duct construction shall conform to the SMACNA *Fibrous Glass Duct Construction Standards* or NAIMA *Fibrous Glass Duct Construction Standards*.
4. Field-fabricated and shop-fabricated metal and flexible duct constructions shall conform to the SMACNA *HVAC Duct Construction Standards—Metal and Flexible* except as allowed by Table M1601.1.1. Galvanized steel shall conform to ASTM A653.
5. The use of gypsum products to construct return air ducts or plenums is permitted, provided that the air temperature does not exceed 125°F (52°C) and exposed surfaces are not subject to condensation.
6. *Duct systems* shall be constructed of materials having a flame spread index of not greater than 200.
7. Stud wall cavities and the spaces between solid floor joists to be used as air plenums shall comply with the following conditions:
 - 7.1. These cavities or spaces shall not be used as a plenum for supply air.
 - 7.2. These cavities or spaces shall not be part of a required fire-resistance-rated assembly.
 - 7.3. Stud wall cavities shall not convey air from more than one floor level.
 - 7.4. Stud wall cavities and joist-space plenums shall be isolated from adjacent concealed spaces by tight-fitting fireblocking in accordance with Section ~~R602.8~~R302.11. Fireblocking materials used for isolation shall comply with Section R302.11.1.
 - 7.5. Stud wall cavities in the outside walls of building envelope assemblies shall not be utilized as air plenums.
8. Volume dampers, equipment and other means of supply, return and exhaust air adjustment used in system balancing shall be provided with access.

M1601.4.5 Fireblocking. Duct installations shall be fireblocked in accordance with Section ~~R602.8~~R302.11.

Reason:

The current text creates an unnecessary step by taking the reader to R602.8, only to be redirected to R302.11.1. This proposal is a nontechnical cleanup of text.

This proposal is submitted by the ICC Plumbing/Mechanical/Gas Code Action Committee (PMG CAC). The PMG CAC was established by the ICC Board of Directors to pursue opportunities to improve and enhance the International Codes or portions thereof that were under the purview of the PMG CAC. In 2017 the PMG CAC held one face-to-face meeting and 11 conference call meetings. Numerous interested parties attended the committee meetings and offered their input.

Cost Impact

The code change proposal will not increase or decrease the cost of construction .

This proposal will not increase the cost of construction because no additional labor, materials, equipment, appliances or devices are mandated beyond what is currently required by the code.

Internal ID: 382

RM33-18

IRC: M1601.1.1.7 (New)

Proponent: Pennie Feehan, representing Plumbing, Mechanical, and Fuel Gas Code Action Committee (PMGCAC@iccsafe.org)

2018 International Residential Code

Add new text as follows:

M1601.1.1.7 Sealing. Building cavities used as plenums shall be sealed.

Reason:

Where stud cavities and joist cavities are used for return air, the negative pressure in the cavities can draw in outdoor air at any point where the cavities abut attic spaces, crawl spaces and outside walls. Sealing of the interface with attics, crawls and outside walls will reduce unwanted infiltration of outdoor air and will improve system efficiency.

This proposal is submitted by the ICC Plumbing/Mechanical/Gas Code Action Committee (PMG CAC). The PMG CAC was established by the ICC Board of Directors to pursue opportunities to improve and enhance the International Codes or portions thereof that were under the purview of the PMG CAC. In 2017 the PMG CAC held one face-to-face meeting and 11 conference call meetings. Numerous interested parties attended the committee meetings and offered their input.

Cost Impact

The code change proposal will increase the cost of construction .

This proposal will increase the cost of construction because additional labor and sealants are required

Internal ID: 381

RM34-18

IRC: M1802.4 (New)

Proponent: Pennie Feehan, representing Plumbing, Mechanical, and Fuel Gas Code Action Committee (PMGCAC@iccsafe.org)

2018 International Residential Code

Add new text as follows:

M1802.4 Blocked vent switch. The venting system for oil-fired appliances shall be equipped with a device that will stop burner operation in the event that the venting system is obstructed. Such device shall have a manual reset, and shall be installed in accordance with the manufacturer's instructions.

Reason:

Such devices can save lives in the event that a chimney or Type L vent is blocked by debris, decaying masonry or dead animals. Gas furnaces are equipped with thermal and/or pressure devices that will sense failure of the venting system, but such is not known to be required for oil-fired appliances. Such devices have been installed for many decades, but not necessarily required. These devices are typically provided for or are an option for draft regulators that are commonly installed in the vent of oil-fired appliances.

This proposal is submitted by the ICC Plumbing/Mechanical/Gas Code Action Committee (PMG CAC). The PMG CAC was established by the ICC Board of Directors to pursue opportunities to improve and enhance the International Codes or portions thereof that were under the purview of the PMG CAC. In 2017 the PMG CAC held one face-to-face meeting and 11 conference call meetings. Numerous interested parties attended the committee meetings and offered their input.

Cost Impact

The code change proposal will increase the cost of construction .

This proposal will increase the cost of construction because an additional device is mandated beyond what is currently required by the code.

Internal ID: 431

RM35-18

IRC: M2101.11 (New), M2101.21.6 (New), M2101.20.4 (New), M2101.21 (New), M2101.21.1 (New), M2101.21.2 (New), M2101.21.3 (New), M2101.21.4 (New), M2101.21.5 (New), M2101.22 (New), M2101.20.2 (New), M2101.23 (New), M2101.24 (New), M2101.25 (New), M2101.26 (New), M2101.27 (New), M2101.28 (New), M2101.28.1 (New), M2101.29 (New), M2101.20.3 (New), M2101.20.1 (New), M2101.12 (New), M2101.17 (New), M2101.13 (New), M2101.13.1 (New), M2101.14 (New), M2101.15 (New), M2101.15.1 (New), M2101.15.2 (New), M2101.16 (New), M2101.16.1 (New), M2101.17.1 (New), M2101.20 (New), M2101.17.2 (New), M2101.18 (New), M2101.18.1 (New), M2101.18.2 (New), M2101.18.3 (New), M2101.19 (New), M2101.19.1 (New), M2101.19.2 (New), M2101.30 (New)

Proponent: Pennie Feehan, representing Plumbing, Mechanical, and Fuel Gas Code Action Committee (PMGCAC@iccsafe.org)

2018 International Residential Code

Add new text as follows:

M2101.11 Used materials. Used pipe, fittings, valves, and other materials shall not be reused in hydronic systems.

M2101.21.6 Expansion tanks. Shutoff valves shall be installed at connections to nondiaphragm-type expansion tanks.

M2101.20.4 Electrofusion joints. Joints shall be of the electrofusion type. Joint surfaces shall be clean and free from moisture and scoured to expose virgin resin. Joint surfaces shall be heated to melt temperatures for the period of time specified by the manufacturer and joined. The joint shall remain undisturbed until cool. Fittings shall be manufactured in accordance with ASTM F105..

M2101.21 PVC plastic pipe. Joints between PVC plastic pipe or fittings shall be solvent-cemented in accordance with Section P2906.9.1.4. Threaded joints between fittings and PVC plastic pipe shall be in accordance with Section M2101.16.1.

M2101.21 Shutoff valves. Shutoff valves shall be installed in ground-source loop piping systems in the locations indicated in Sections M2101.21.1 through M2101.21.6.

M2101.21.1 Heat exchangers. Shut off valves shall be installed on the supply and return side of a heat exchanger.

Exception: Shutoff valves shall not be required where heat exchangers are integral with a boiler or are a component of a manufacturer's boiler and heat exchanger packaged unit and are capable of being isolated from the hydronic system by the supply and return valves required by Section M2001.3.

M2101.21.2 Central systems. Shutoff valves shall be installed on the building supply and return of a central utility system.

M2101.21.3 Pressure vessels. Shutoff valves shall be installed on the connection to any pressure vessel.

M2101.21.4 Pressure-reducing valves. Shutoff valves shall be installed on both sides of a pressure-reducing valve.

M2101.21.5 Equipment and appliances. Shutoff valves shall be installed on connections to mechanical equipment and appliances. This requirement does not apply to components of ground-source loop systems such as pumps, air separators, metering devices, and similar equipment.

M2101.22 Reduced pressure. A pressure relief valve shall be installed on the low-pressure side of a hydronic piping system that has been reduced in pressure. The relief valve shall be set at the maximum pressure of the system design. The valve shall be installed in accordance with Section M2002.

M2101.20.2 PE-RT-to-metal connections. Solder joints in a metal pipe shall not occur within 18 inches (457 mm) of a transition from such metal pipe to PE-RT pipe or tubing.

M2101.23 Installation. Piping, valves, fittings, and connections shall be installed in accordance with the manufacturer's instructions.

M2101.24 Protection of potable water. Where hydronic systems have a connection to a potable water supply,

the potable water system shall be protected from backflow in accordance with Section P2902.

M2101.25 Pipe penetrations. Openings for pipe penetrations in walls, floors and ceilings shall be larger than the penetrating pipe. Openings through concrete or masonry building elements shall be sleeved. The annular space surrounding pipe penetrations shall be protected in accordance with Section P2606.1.

M2101.26 Clearance from combustibles. A pipe in a piping system having an exterior surface temperature exceeding 250°F (121°C) shall have a clearance of not less than 1 inch (25 mm) from combustible materials.

M2101.27 Contact with building material. A piping system shall not be in direct contact with building materials that cause the piping or fitting material to degrade or corrode, or that interfere with the operation of the system.

M2101.28 Strains and stresses. Piping shall be installed so as to prevent detrimental strains and stresses in the pipe. Provisions shall be made to protect piping from damage resulting from expansion, contraction and structural settlement. Piping shall be installed so as to avoid structural stresses or strains within building components.

M2101.28.1 Flood hazard. Piping located in a flood hazard area shall be capable of resisting hydrostatic and hydrodynamic loads and stresses, including the effects of buoyancy, during the occurrence of flooding to the design flood elevation.

M2101.29 Chemical compatibility. Antifreeze and other materials used in the system shall be chemically compatible with the pipe, tubing, fittings and mechanical systems.

M2101.20.3 Heat-fusion joints. Heat-fusion joints shall be of the socket-fusion, saddle-fusion or butt-fusion type, and shall be joined in accordance with ASTM D2657. Joint surfaces shall be clean and free from moisture. Joint surfaces shall be heated to melt temperatures and joined. The joint shall remain undisturbed until cool. Fittings shall be manufactured in accordance with ASTM D2683 or ASTM D3261.

M2101.20.1 Compression-type fittings. Where compression-type fittings include inserts and ferrules or O-rings, the fittings shall be installed without omitting the inserts and ferrules or O-rings.

M2101.12 Material rating. Pipe and tubing shall be rated for the operating temperature and pressure of the system. Fittings shall be suitable for the pressure applications and recommended by the manufacturer for installation with the pipe and tubing material installed. Where used underground, materials shall be suitable for burial.

M2101.17 Cross-linked polyethylene (PEX) plastic tubing. Joints between cross-linked polyethylene plastic tubing and fittings shall comply with Sections M2101.17.1 and M2101.17.2. Mechanical joints shall comply with Section M2101.15.1.

M2101.13 Joints and connections. Joints and connections shall be of an approved type. Joints and connections shall be tight for the pressure of the system. Joints used underground shall be approved for such applications.

M2101.13.1 Joints between different piping materials. Joints between different piping materials shall be made with approved transition fittings.

M2101.14 Preparation of pipe ends. Pipe shall be cut square, reamed, and shall be free of burrs and obstructions. CPVC, PE, and PVC pipe shall be chamfered. Pipe ends shall have full-bore openings and shall not be undercut.

M2101.15 Joint preparation and installation. Where required by Sections M2101.16 through M2101.18, the preparation and installation of mechanical and thermoplastic-welded joints shall comply with Sections M2101.15.1 and M2101.15.2.

M2101.15.1 Mechanical joints. Mechanical joints shall be installed in accordance with the manufacturer's instructions.

M2101.15.2 Thermoplastic-welded joints. Joint surfaces for thermoplastic-welded joints shall be cleaned by an approved procedure. Joints shall be welded in accordance with the manufacturer's instructions.

M2101.16 CPVC plastic pipe. Joints between CPVC plastic pipe or fittings shall be solvent-cemented in accordance with Section P2906.9.1.2. Threaded joints between fittings and CPVC plastic pipe shall be in accordance with Section M2101.16.1

M2101.16.1 Threaded joints. Threads shall conform to ASME B1.20.1 The pipe shall be Schedule 80 40 or heavier plastic pipe and shall be threaded with dies specifically designed for plastic pipe. Thread lubricant, pipe-joint compound or tape shall be applied on the male threads only and shall be approved for application on the piping material.

M2101.17.1 Compression-type fittings. Where compression-type fittings include inserts and ferrules or O-rings, the fittings shall be installed without omitting the inserts and ferrules or O-rings.

M2101.20 Raised temperature polyethylene (PE-RT) plastic tubing. Joints between raised temperature polyethylene tubing and fittings shall comply with Sections M2101.20.1 through M2101.20.4. Mechanical joints shall comply with Section M2101.15.1.

M2101.17.2 Plastic-to-metal. Solder joints in a metal pipe shall not occur within 18 inches (457 mm) of a transition from such metal pipe to plastic pipe or tubing.

M2101.18 Polyethylene plastic pipe and tubing. Joints between polyethylene plastic pipe and tubing or fittings for systems shall be heat-fusion joints complying with Section M2101.18.1, electrofusion joints complying with Section M2101.18.2, or stab-type insertion joints complying with Section M2101.18.3.

M2101.18.1 Heat-fusion joints. Joints shall be of the socket-fusion, saddle-fusion or butt-fusion type, and joined in accordance with ASTM D2657. Joint surfaces shall be clean and free from moisture. Joint surfaces shall be heated to melt temperatures and joined. The joint shall remain undisturbed until cool. Fittings shall be manufactured in accordance with ASTM D2683 or ASTM D3261.

M2101.18.2 Electrofusion joints. Joints shall be of the electrofusion type. Joint surfaces shall be clean and free from moisture, and scoured to expose virgin resin. Joint surfaces shall be heated to melt temperatures for the period of time specified by the manufacturer. The joint shall remain undisturbed until cool. Fittings shall be manufactured in accordance with ASTM F1055.

M2101.18.3 Stab-type insert fittings. Joint surfaces shall be clean and free from moisture. Pipe ends shall be chamfered and inserted into the fittings to full depth. Fittings shall be manufactured in accordance with ASTM F1924.

M2101.19 Polypropylene (PP) plastic. Joints between PP plastic pipe and fittings shall comply with Sections M2101.19.1 and M2101.19.2.

M2101.19.1 Heat-fusion joints. Heat-fusion joints for polypropylene (PP) pipe and tubing joints shall be installed with socket-type heat-fused polypropylene fittings, electrofusion polypropylene fittings or by butt fusion. Joint surfaces shall be clean and free from moisture. The joint shall remain undisturbed until cool. Joints shall be made in accordance with ASTM F2389.

M2101.19.2 Mechanical and compression sleeve joints. Mechanical and compression sleeve joints shall be installed in accordance with the manufacturer's instructions.

M2101.30 Makeup water. The transfer fluid shall be compatible with the makeup water supplied to the system.

Reason:

This proposal fills a gap in the code coverage for hydronic piping. The new text is simply borrowed from Section M1205 which is specific to ground-source heat-pump loop piping. The same requirements also need to apply to all hydronic piping systems under Section M2101, not just ground-source heat-pump systems. This proposal provides the same coverage for general hydronic systems as is currently required for ground-source heat-pump systems.

This proposal is submitted by the ICC Plumbing/Mechanical/Gas Code Action Committee (PMG CAC). The PMG CAC was established by the ICC Board of Directors to pursue opportunities to improve and enhance the International Codes or portions thereof that were under the purview of the PMG CAC. In 2017 the PMG CAC held one face-to-face meeting and 11 conference call meetings. Numerous interested parties attended the committee meetings and offered their input.

Cost Impact

The code change proposal will not increase or decrease the cost of construction .

This proposal will not increase the cost of construction because no additional labor, materials, equipment, appliances or devices are mandated beyond what is currently required by the code.

RM36-18

IRC: TABLE M2105.4

Proponent: LANCE MacNevin, Plastics Pipe Institute, representing Plastics Pipe Institute (lmacnevin@plasticpipe.org); Mark Metzner, IGSHPA Canada, representing IGSHPA Canada (markmetzner@shaw.ca)

2018 International Residential Code

Revise as follows:

**TABLE M2105.4
GROUND-SOURCE LOOP PIPE**

MATERIAL	STANDARD
Chlorinated polyvinyl chloride (CPVC)	ASTM D2846; ASTM F437; ASTM F438; ASTM F439; ASTM F441; ASTM F442; CSA B137.6
Cross-linked polyethylene (PEX)	ASTM F876; CSA B137.5; <u>CSA C448</u>
High-density polyethylene (HDPE)	ASTM D2737; ASTM D3035; ASTM F714; AWWA C901; CSA B137.1; CSA C448; NSF 358-1
Polyethylene/aluminum/polyethylene (PE-AL-PE) pressure pipe	ASTM F1282; AWWA C 903; CSA B137.9
Polypropylene (PP-R)	ASTM F2389; CSA B137.11, NSF 358-2
Polyvinyl chloride (PVC)	ASTM D1785; ASTM D2241; CSA 137.3
Raised temperature polyethylene (PE-RT)	ASTM F2623; ASTM F2769, CSA B137.18; <u>CSA C448</u>

Reason:

This proposal is on behalf of the International Ground Source Heat Pump Association (IGSHPA); Mark Metzner - President of IGSHPA Canada and the Chairman of ANSI/CSA/IGSHPA C448; and The Plastics Pipe Institute.

ANSI/CSA/IGSHPA C448-16 “Design and installation of ground source heat pump systems for commercial and residential buildings” is an ANSI designated bi-national consensus standard for the design and installation of ground source heat pump systems. It was first published in February 2016.

ANSI/CSA/IGSHPA C448-16 replaces the original version known as CSA C448-02. ANSI/CSA/IGSHPA C448-16 is a greatly enhanced system standard which includes the industry knowledge of ground source geothermal systems gained since 2002.

ANSI/CSA/IGSHPA C448-16 contains specific requirements for HDPE, PEX and PE-RT piping systems (pipe and fittings) for use as ground loop piping systems. By adding reference to C448 in these rows, this will indicate that these materials (PEX and PE-RT) are explicitly approved in ANSI/CSA/IGSHPA C448-16.

Cost Impact

The code change proposal will not increase or decrease the cost of construction .

The code change proposal will not increase or decrease the cost of construction because it is simply identifying another industry consensus standard (C448) to which existing materials PEX and PE-RT can comply.

Analysis: A review of the standard proposed for inclusion in the code, with regard to the ICC criteria for referenced standards (Section 3.6 of CP#28) will be posted on the ICC website on or before April 2, 2018.

Internal ID: 2263

RM37-18

IRC: M2105.17

Proponent: LANCE MacNevin, Plastics Pipe Institute, representing Plastics Pipe Institute (lmacnevin@plasticpipe.org); Mark Metzner, IGSHPA Canada, representing IGSHPA Canada (markmetzner@shaw.ca)

2018 International Residential Code

Revise as follows:

M2105.17 Installation. Piping, valves, fittings, and connections shall be installed in accordance with ANSI/CSA/IGSHPA C448 and the manufacturer's instructions.

Reason:

This proposal is on behalf of the International Ground Source Heat Pump Association (IGSHPA); Mark Metzner - President of IGSHPA Canada and the Chairman of ANSI/CSA/IGSHPA C448; and The Plastics Pipe Institute.

ANSI/CSA/IGSHPA C448-16 "Design and installation of ground source heat pump systems for commercial and residential buildings" is an ANSI designated bi-national consensus standard for the design and installation of ground source heat pump systems. It was first published in February 2016.

ANSI/CSA/IGSHPA C448-16 is the first ANSI approved consensus standard for the design and installation of ground source systems.

ANSI/CSA/IGSHPA C448-16 replaces the original version known as CSA C448-02. ANSI/CSA/IGSHPA C448-16 is a greatly enhanced system standard which includes the industry knowledge of ground source geothermal systems gained since 2002. Ground loop piping system installations should be in accordance with the requirements of this standard.

The Standard includes performance-based criteria that provides a consistent application of requirements and best practices throughout the United States and Canada. This Standard will ensure that stakeholders in the ground source heat pump systems market sector will supply and receive ground source heating / cooling systems that perform to design efficiency expectations and deliver true, long-term value.

This Standard was developed by a Binational Technical Committee which comprised of the industry's leaders from Canada and USA, including representatives of the following industry associations:

American Society for Heating, Refrigeration and Air Conditioning Engineers (ASHRAE)

Geothermal Exchange Organization (GEO)

International Ground Source Heat Pump Association (IGSPHA)

International Ground Source Heat Pump Association Canada (IGSPHA - Canada)

National Ground Water Association (NGWA)

The Plastics Pipe Institute (PPI)

Geothermal National & International Initiative (GEONII)

Heating, Refrigeration and Air Conditioning Institute of Canada (HRAI)

ANSI/CSA/IGSHPA C448-16 includes performance-based minimum requirements for industrial, commercial, institutional and residential applications. It addresses the following items related to ground source heat pump systems:

equipment and material selection (including ground loop piping)

site survey - geological and hydrogeological

open and closed loop ground source heat pump system design / engineering

direct expansion (DX) systems

installation

testing and verification

documentation

commissioning and decommissioning

ANSI/CSA/IGSHPA C448-16 applies to all ground source heat pump systems using outdoor ground loop heat exchangers as a thermal source or sink for heating and cooling, with or without supplementary heating or cooling source/s. The types of outdoor heat exchangers covered by this Standard include:

ground heat exchangers - vertical and horizontal

open-loop systems - drilled well and surface water

submerged closed loop systems - fresh water and sea water

standing column wells

Cost Impact

The code change proposal will not increase or decrease the cost of construction .

The code change proposal will not increase or decrease the cost of construction because it is simply clarifying that ground loop pipes must be installed correctly, in accordance with the latest version of this industry consensus standard which is already referenced in the IMC and IRC.

Analysis: A review of the standard proposed for inclusion in the code, with regard to the ICC criteria for referenced standards (Section 3.6 of CP#28) will be posted on the ICC website on or before April 2, 2018.

Internal ID: 2274

RM38-18

IRC: TABLE M2105.5

Proponent: LANCE MacNevin, Plastics Pipe Institute, representing Plastics Pipe Institute (lmacnevin@plasticpipe.org); Mark Metzner, IGSHPA Canada, representing IGSHPA Canada (markmetzner@shaw.ca)

2018 International Residential Code

**TABLE M2105.5
GROUND-SOURCE LOOP PIPE FITTINGS**

PIPE MATERIAL	STANDARD
Chlorinated polyvinyl chloride (CPVC)	ASTM D2846; ASTM F437; ASTM F438; ASTM F439; ASTM F1970; CSA B137.6
Cross-linked polyethylene (PEX)	ASTM F877; ASTM F1807; ASTM F1960; ASTM F2080; ASTM F2159; ASTM F2434; CSA B137.5; <u>CSA C448</u>
High-density polyethylene (HDPE)	ASTM D2683; ASTM D3261; ASTM F1055; CSA B137.1; <u>CSA C448</u> ; NSF 358-1
Polyethylene/aluminum/polyethylene (PE-AL-PE)	ASTM F1282; ASTM F2434; CSA B137.9
Polypropylene (PP-R)	ASTM F2389; CSA B137.11; NSF 358-2
Polyvinyl chloride (PVC)	ASTM D2464; ASTM D2466; ASTM D2467; ASTM F1970, CSA B137.2; CSA B137.3
Raised temperature polyethylene (PE-RT)	ASTM D2683; ASTM D3261; ASTM F1055; ASTM F1807; ASTM F2098; ASTM F2159; ASTM F2735; ASTM F2769; CSA B137.1; CSA B137.18; <u>CSA C448</u>

Reason:

This proposal is on behalf of the International Ground Source Heat Pump Association (IGSHPA); Mark Metzner – President of IGSHPA Canada and the Chairman of ANSI/CSA/IGSHPA C448; and The Plastics Pipe Institute.

ANSI/CSA/IGSHPA C448-16 “Design and installation of ground source heat pump systems for commercial and residential buildings” is an ANSI designated bi-national consensus standard for the design and installation of ground source heat pump systems. It was first published in February 2016.

ANSI/CSA/IGSHPA C448-16 contains specific requirements for HDPE, PEX and PE-RT piping systems (pipe and fittings) for use as ground loop piping systems. By adding reference to C448 in this row, this will indicate that these materials (PEX and PE-RT) are explicitly approved in ANSI/CSA/IGSHPA C448-16.

Cost Impact

The code change proposal will not increase or decrease the cost of construction .

The code change proposal will not increase or decrease the cost of construction because it is simply identifying another industry consensus standard (C448) to which existing fittings for use with PEX and PE-RT can comply.

Analysis: A review of the standard proposed for inclusion in the code, with regard to the ICC criteria for referenced standards (Section 3.6 of CP#28) will be posted on the ICC website on or before April 2, 2018.

Internal ID: 2267

RM39-18

IRC: TABLE M2105.4, TABLE M2105.5, ordinal

Proponent: Jeremy Brown, representing NSF International (brown@nsf.org)

2018 International Residential Code

Revise as follows:

**TABLE M2105.4
GROUND-SOURCE LOOP PIPE**

MATERIAL	STANDARD
Chlorinated polyvinyl chloride (CPVC)	ASTM D2846; ASTM F437; ASTM F438; ASTM F439; ASTM F441; ASTM F442; CSA B137.6
Cross-linked polyethylene (PEX)	ASTM F876; CSA B137.5
High-density polyethylene (HDPE)	ASTM D2737; ASTM D3035; ASTM F714; AWWA C901; CSA B137.1; CSA C448; NSF 358-1
Polyethylene/aluminum/polyethylene (PE-AL-PE) pressure pipe	ASTM F1282; AWWA C 903; CSA B137.9
Polypropylene (PP-R)	ASTM F2389; CSA B137.11, NSF 358-2
Polyvinyl chloride (PVC)	ASTM D1785; ASTM D2241; CSA 137.3
Raised temperature polyethylene (PE-RT)	ASTM F2623; ASTM F2769, CSA B137.18, <u>NSF358-4</u>

**TABLE M2105.5
GROUND-SOURCE LOOP PIPE FITTINGS**

PIPE MATERIAL	STANDARD
Chlorinated polyvinyl chloride (CPVC)	ASTM D2846; ASTM F437; ASTM F438; ASTM F439; ASTM F1970; CSA B137.6
Cross-linked polyethylene (PEX)	ASTM F877; ASTM F1807; ASTM F1960; ASTM F2080; ASTM F2159; ASTM F2434; CSA B137.5
High-density polyethylene (HDPE)	ASTM D2683; ASTM D3261; ASTM F1055; CSA B137.1; CSA C448; NSF 358-1
Polyethylene/aluminum/polyethylene (PE-AL-PE)	ASTM F1282; ASTM F2434; CSA B137.9
Polypropylene (PP-R)	ASTM F2389; CSA B137.11; NSF 358-2
Polyvinyl chloride (PVC)	ASTM D2464; ASTM D2466; ASTM D2467; ASTM F1970; CSA B137.2; CSA B137.3
Raised temperature polyethylene (PE-RT)	ASTM D2683; ASTM D3261; ASTM F1055; ASTM F1807; ASTM F2098; ASTM F2159; ASTM F2735; ASTM F2769; CSA B137.1; CSA B137.18, <u>NSF 358-4</u>

Add new standard(s) follows:

NSF

NSF International
789 N. Dixboro Road P.O. Box
130140
Ann Arbor MI 48105
US

NSF 358-4-2017:

Polyethylene of raised temperature (PE-RT) pipe and fittings for water-based ground-source (geothermal) heat pump systems

Reason:

At the proposal deadline, NSF 358-4 was still a draft standard, but it is expected to be published prior to the public hearing. The balloted draft standard will be submitted with the proposal. Anyone may receive a complimentary copy of this draft standard for the purpose of reviewing this proposal by emailing brown@nsf.org.

These tables contain the acceptable materials for geothermal ground loop pipe and fittings. PE-RT piping and associated fittings are already accepted materials with referenced standards. NSF 358-4 is a proposed ANSI standard written specifically to contain requirements for PE-RT geothermal piping and fittings. Companion standards NSF 358-1 (PE) and NSF 358-3(PP) are already approved in this table. NSF 358-4 addresses performance pressure testing, long term strength, chemical resistance, constant tensile load joint testing, suitability for burial and marking specific to geothermal PE-RT piping systems.

Cost Impact

The code change proposal will not increase or decrease the cost of construction .

Providing an additional option is cost neutral.

Analysis: A review of the standard proposed for inclusion in the code, with regard to the ICC criteria for referenced standards (Section 3.6 of CP#28) will be posted on the ICC website on or before April 2, 2018.

Internal ID: 1088

RM40-18

IRC: TABLE M2105.4, TABLE M2105.5, ordinal

Proponent: Jeremy Brown, representing NSF International (brown@nsf.org)

2018 International Residential Code

Revise as follows:

**TABLE M2105.4
GROUND-SOURCE LOOP PIPE**

MATERIAL	STANDARD
Chlorinated polyvinyl chloride (CPVC)	ASTM D2846; ASTM F437; ASTM F438; ASTM F439; ASTM F441; ASTM F442; CSA B137.6
Cross-linked polyethylene (PEX)	ASTM F876; CSA B137.5, <u>NSF 358-3</u>
High-density polyethylene (HDPE)	ASTM D2737; ASTM D3035; ASTM F714; AWWA C901; CSA B137.1; CSA C448; NSF 358-1
Polyethylene/aluminum/polyethylene (PE-AL-PE) pressure pipe	ASTM F1282; AWWA C 903; CSA B137.9
Polypropylene (PP-R)	ASTM F2389; CSA B137.11, NSF 358-2
Polyvinyl chloride (PVC)	ASTM D1785; ASTM D2241; CSA 137.3
Raised temperature polyethylene (PE-RT)	ASTM F2623; ASTM F2769, CSA B137.18

**TABLE M2105.5
GROUND-SOURCE LOOP PIPE FITTINGS**

PIPE MATERIAL	STANDARD
Chlorinated polyvinyl chloride (CPVC)	ASTM D2846; ASTM F437; ASTM F438; ASTM F439; ASTM F1970; CSA B137.6
Cross-linked polyethylene (PEX)	ASTM F877; ASTM F1807; ASTM F1960; ASTM F2080; ASTM F2159; ASTM F2434; CSA B137.5, <u>NSF 358-3</u>
High-density polyethylene (HDPE)	ASTM D2683; ASTM D3261; ASTM F1055; CSA B137.1; CSA C448; NSF 358-1
Polyethylene/aluminum/polyethylene (PE-AL-PE)	ASTM F1282; ASTM F2434; CSA B137.9
Polypropylene (PP-R)	ASTM F2389; CSA B137.11; NSF 358-2
Polyvinyl chloride (PVC)	ASTM D2464; ASTM D2466; ASTM D2467; ASTM F1970, CSA B137.2; CSA B137.3
Raised temperature polyethylene (PE-RT)	ASTM D2683; ASTM D3261; ASTM F1055; ASTM F1807; ASTM F2098; ASTM F2159; ASTM F2735; ASTM F2769; CSA B137.1; CSA B137.18

Add new standard(s) follows:

NSF

NSF International
789 N. Dixboro Road P.O. Box
130140
Ann Arbor MI 48105
US

358-3-2016:

Cross-linked polyethylene (PEX) pipe and fittings for water-based ground-source (geothermal) heat pump systems

Reason:

These tables contain the acceptable materials for geothermal ground loop pipe and fittings. PEX piping and associated fittings are already accepted materials with referenced standards. NSF 358-3 is an ANSI standard written specifically to contain requirements for PEX geothermal piping and fittings. Companion standards NSF 358-1 (PE) and NSF 358-3(PP) are already approved in this table. NSF 358-3 addresses performance pressure testing, long term strength, chemical resistance, constant tensile load joint testing, suitability for burial and marking specific to geothermal PEX piping systems. Anyone wishing to receive a complimentary copy of this standard for the purpose of reviewing this code change can send an email to brown@nsf.org

Cost Impact

The code change proposal will not increase or decrease the cost of construction .
Adding an additional standard choice will not increase the cost of construction.

Analysis: A review of the standard proposed for inclusion in the code, with regard to the ICC criteria for referenced standards (Section 3.6 of CP#28) will be posted on the ICC website on or before April 2, 2018.

Internal ID: 1082

RM41-18

IRC: TABLE M2101.1

Proponent: Gary Morgan, Viega LLC, representing Viega LLC (gary.morgan@viega.us); LANCE MacNevin, Plastics Pipe Institute, representing Plastics Pipe Institute (Lmacnevin@plasticpipe.org)

2018 International Residential Code

Revise as follows:

TABLE M2101.1

HYDRONIC PIPING AND FITTING MATERIALS

MATERIAL	USE CODE ^a	STANDARD ^b	JOINTS	NOTES
Acrylonitrile butadiene styrene (ABS) plastic pipe	1, 5	ASTM D1527 ASTM F2806 ASTM F2969	Solvent cement joints	—
Chlorinated poly (vinyl chloride) (CPVC) pipe and tubing	1, 2, 3	ASTM D2846	Solvent cement joints, compression joints and threaded adapters	—
Copper and copper-alloy pipe	1	ASTM B42, B43, B302	Brazed, soldered and mechanical fittings threaded, welded and flanged	—
Copper and copper-alloy tubing (Type K, L or M)	1, 2	ASME B16.51, ASTM B75, B88, B135, B251, B306	Brazed, soldered, press-connected and flared mechanical fittings	Joints embedded in concrete shall be brazed
Cross-linked polyethylene (PEX)	1, 2, 3	ASTM F876, ASTM F3253	(See PEX fittings)	Install in accordance with manufacturer's instructions
Cross-linked polyethylene/aluminum/cross-linked polyethylene (PEX-AL-PEX) pressure pipe	1, 2	ASTM F1281 or CAN/CSA B137.10	Mechanical, crimp/insert	Install in accordance with manufacturer's instructions
PEX fittings		ASTM F877 ASTM F1807 ASTM F1960 ASTM F2098 ASTM F2159 ASTM F2735; ASTM F3253	Copper crimp/insert fittings, cold expansion fittings, stainless steel clamp, insert fittings	Install in accordance with manufacturer's instructions
Polybutylene (PB) pipe and tubing	1, 2, 3	ASTM D3309	Heat-fusion, crimp/insert and compression	Joints in concrete shall be heat-fused
Polyethylene/aluminum/polyethylene (PE-AL-PE) pressure pipe	1, 2, 3	ASTM F1282 CSA B 137.9	Mechanical, crimp/insert	—
Polypropylene (PP)	1, 2, 3	ISO 15874 ASTM F2389	Heat-fusion joints, mechanical fittings, threaded adapters, compression joints	—
Raised temperature polyethylene (PE-RT)	1, 2, 3	ASTM F2623 ASTM F2769, CSA B137.18	Copper crimp/insert fitting, stainless steel clamp, insert fittings	—
Raised temperature polyethylene (PE-RT) fittings	1, 2, 3	ASTM D3261 ASTM F1807 ASTM F2098 ASTM F2159 ASTM F2735 ASTM F2769 CSA B137.18	Copper crimp/insert fitting, stainless steel clamp, insert fittings	—
Steel pipe	1, 2	ASTMA53 ASTMA106	Brazed, welded, threaded, flanged and mechanical fittings	Joints in concrete shall be welded. Galvanized pipe shall not be welded or brazed.
Steel tubing	1	ASTMA254	Mechanical fittings, welded	—

For SI: °C = [(°F)-32]/1.8.

- a. Use code:
 1. Above ground.
 2. Embedded in radiant systems.
 3. Temperatures below 180°F only.
 4. Low temperature (below 130°F) applications only.
 5. Temperatures below 160°F only.
- b. Standards as listed in Chapter 44.

Reason:

ASTM's committee on plastics piping recently completed a new Standard, F3253 - Standard Specification for Crosslinked Polyethylene (PEX) Tubing with Oxygen Barrier for Hot - and Cold - Water Hydronic Distribution Systems. This new system standard covers both the oxygen barrier PEX tubing as well as the performance and material requirements for the fittings. While this standard essentially mirrors the existing ASTM F876 and F877 PEX standards from a dimensional standpoint and existing fittings interchangeability, it also mandates the inclusion of an oxygen barrier layer with defined pass/fail criteria essentially equal with the industry's long accepted norm of DIN 4726 concerning allowed oxygen permeation. This new standard also requires a minimum pull-out strength test for the fittings not included in ASTM F877 today. The inclusion of this new standard in no way changes the acceptance of the existing ASTM F876 and F877 which will remain in the mechanical hydronics code for the foreseeable future.

This standard's project has been in works for nearly 4 years and represents the work and input from nearly all of the PEX tubing manufacturers in North America. Your support of this proposal is most appreciated.

A similar proposal is being submitted for Chapter 12 of the IMC.

Cost Impact

The code change proposal will not increase or decrease the cost of construction .

The addition of this new standard simply offers an alternative product that uses products which are relatively identical in cost today to existing pipe and fitting materials.

Internal ID: 1762

RM42-18

IRC: M2105.7

Proponent: Gary Morgan, representing Viega LLC (gary.morgan@viega.us)

2018 International Residential Code

M2105.7 Preparation of pipe ends. Pipe shall be cut square, ~~reamed,~~ and shall be free of burrs and obstructions. ~~CPVC, PE and PVC pipe shall be chamfered.~~ Pipe ends shall have full-bore openings and shall ~~not be undercut.~~ be prepared in accordance with the pipe manufacturer's instructions.

Reason:

This section is specific to plastic pipes and some of the existing language refers to terms such as "reamed" and "undercut" which only apply to metallic pipes. The revised language is more appropriate by including reference to preparing pipe ends in accordance with manufacturer's instructions which will be specific to that particular type of plastic pipe.

Cost Impact

The code change proposal will not increase or decrease the cost of construction .

This is only a clarification of existing language and will not result in any increased cost of construction.

Internal ID: 1829

RM43-18

IRC: M2202.1

Proponent: Mark Fasel, Viega, representing Viega LLC (mark.fasel@viega.us)

2018 International Residential Code

Revise as follows:

M2202.1 Materials. Piping shall consist of steel pipe, copper and copper-alloy pipe and tubing, steel tubing conforming to ASTM A539 or stainless steel tubing conforming to ASTM A254 or ASTM A539-A269. Aluminum tubing shall not be used between the fuel-oil tank and the burner units.

Reason:

Stainless steel tubing is an accepted material in accordance with NFPA 31 Standard for the Installation of Oil-Burning Equipment section 8.2.2.1 and is widely used in these applications due to its corrosion-resistance.

Bibliography:

® NFPA

NFPA 31 Standard for the Installation of Oil-Burning Equipment

Section 8.2.2.1

2016

Page 24

<http://www.nfpa.org/>

Cost Impact

The code change proposal will not increase or decrease the cost of construction .

This proposal simply adds stainless steel pipe as an additional piping material that can be used for these applications and therefore will not increase the costs of construction.

Internal ID: 768

RM44-18

IRC: Chapter 22, M2202.2

Proponent: Mark Fasel, representing Viega LLC (mark.fasel@viega.us)

2018 International Residential Code

CHAPTER 22 SPECIAL PIPING AND STORAGE SYSTEMS

Revise as follows:

M2202.2 Joints and fittings. Piping shall be connected with standard fittings compatible with the piping material. Cast-iron fittings shall not be used for oil piping. Unions requiring gaskets or packings, right or left couplings, and sweat fittings employing solder having a melting point less than 1,000°F (538°C) shall not be used for oil piping. Threaded joints and connections shall be made tight with a lubricant or pipe thread compound. Press-Connect joints shall be listed and labeled and shall be installed in accordance with the manufacturer's instructions.

Reason:

Press-Connect joints have been tested and listed for use in fuel oil piping systems and are referenced in the International Mechanical Code in Chapter 13 Fuel Oil Piping and Storage.

Bibliography:

UL 180 Standard for Liquid-Level Indicating Gauges for Oil Burner Fuels.

Underwriters Laboratories

Published 2012

www.ul.com

Cost Impact

The code change proposal will not increase or decrease the cost of construction .

This standard is not the only standard the pipe fittings can meet in accordance with the Pipe Fittings Table, this is just an alternative standard that some manufacturer's have tested their products to and would like to see recognized as an acceptable standard for pipe fittings. Testing to this standard is optional and no existing standards have been removed or replaced by the proposed addition of this standard

Internal ID: 770

RM45-18

IRC: M2202.2

Proponent: Mark Fasel, representing Viega LLC (mark.fasel@viega.us)

2018 International Residential Code

Revise as follows:

M2202.2 Joints and fittings. Piping shall be connected with ~~standard~~ fittings compatible with the piping material. Cast-iron fittings shall not be used for oil piping. Unions requiring gaskets or packings, right or left couplings, and sweat fittings employing solder having a melting point less than 1,000°F (538°C) shall not be used for oil piping. Threaded joints and connections shall be made tight with a lubricant or pipe thread compound.

Reason:

Editorial: The term "standard fittings" is not used in any International codes and has no definition. There is no reason to state the word "standard".

Cost Impact

The code change proposal will not increase or decrease the cost of construction .

The removal of the term standard fittings has no cost implications due to the fact this terminology has no requirements for listings or required testing associated with this proposal to remove this vague undefined terminology.

Internal ID: 861

**2018 GROUP A – PROPOSED CHANGES TO THE
INTERNATIONAL RESIDENTIAL CODE – PLUMBING/
MECHANICAL**

PLUMBING/MECHANICAL CODE COMMITTEE

W. Travis Lindsey, MCP, Chair

Sr. Plans Examiner
City of Scottsdale
Scottsdale, AZ

Marguerite Carroll, Vice Chair

Codes and Regulatory Services Manager
Underwriters Laboratories
Fremont, CA

John Ainslie

Rep: National Association of Home Builders
Owner
Ainslie Group
Virginia Beach, VA

Richard C. Anderson

Division Manager/Deputy Building Official
City of Austin
Austin, TX

Roland Asp, CET

Manager of Installation Standards
National Fire Sprinkler Association
Linthicum Heights, MD

Pennie Feehan

Rep: Copper Development Association
Owner
Pennie L. Feehan Consulting
Palm Springs, CA

R. L. Ric Johnson, CAPS, DHTI+

Rep: National Association of Home Builders
President/CEO
Right at Home Technologies
Ada, OH

Nick McAndrew, PE

Professional Engineer I (Civil/Construction)
NY Department of State Division of Buildings
Standards and Codes
Albany, NY

David W. Perry

Sr. Combination Inspector
City of Richardson
Richardson, TX

Thomas Polino

Plumbing Subcode Official
West Windsor Township
West Windsor, NJ

Loren K. Swanson, BSIE

Rep: National Association of Home Builders
Retired from Southern Michigan Co.
Jackson, MI

Jeremy Wright

Rep: National Association of Home Builders
President
J. Wright Building Company
J. Wright Home Design
Birmingham, AL

Staff Secretariat:

Fred Grable, PE

Senior Staff Engineer - Plumbing
International Code Council
Central Regional Office
Country Club Hills, IL

Gregg Gress

Senior Technical Staff
International Code Council
Central Regional Office
4051 W. Flossmoor Rd
Country Club Hills, IL

TENTATIVE ORDER OF DISCUSSION 2018 PROPOSED CHANGES TO THE INTERNATIONAL RESIDENTIAL BUILDING CODE – PLUMBING

The following is the tentative order in which the proposed changes to the code will be discussed at the public hearings. Proposed changes which impact the same subject have been grouped to permit consideration in consecutive changes.

Proposed change numbers that are indented are those which are being heard out of numerical order. Indentation does not necessarily indicate that one change is related to another. Proposed changes may be grouped for purposes of discussion at the hearing at the discretion of the chair. Note that some RP code change proposals may not be included on this list, as they are being heard by another committee.

P1-18 Part II	RP12-18
RB4-18	P131-18 Part II
P58-18 Part II	P132-18 Part II
RP1-18	P103-18 Part II
RP2-18	P106-18 Part II
P11-18 Part II	P109-18 Part II
P8-18 Part II	P113-18 Part II
P7-18 Part II	P133-18 Part II
RP3-18	RP13-18
P63-18 Part II	P115-18 Part II
P44-18 Part II	RP14-18
P45-18 Part II	
P46-18 Part II	
RP4-18	
P47-18 Part II	
P50-18 Part II	
P48-18 Part II	
P33-18 Part II	
P71-18 Part II	
F14-18 Part II	
P97-18 Part II	
P98-18 Part II	
P79-18 Part II	
P82-18 Part II	
RP16-18	
P77-18 Part II	
RP5-18	
RP6-18	
RP7-18	
RP8-18	
RP9-18	
RP10-18	
RP15-18	
P87-18 Part II	
P88-18 Part II	
RP11-18	
P89-18 Part II	

RP1-18

IRC: P2503.4

Proponent: Gary Kozan, Ridgeway Plumbing, representing Ridgeway Plumbing (garyk@ridgewayplumbing.com)

2018 International Residential Code

Revise as follows:

P2503.4 Building sewer testing. The *building sewer* shall be tested by insertion of a test plug at the point of connection with the public sewer, filling the *building sewer* with water and pressurizing the sewer to not less than a ~~10~~5-foot (3048 mm) head of water. The test pressure shall not decrease during a period of not less than 15 minutes. The *building sewer* shall be water tight at all points.

A forced sewer test shall consist of pressurizing the piping to a pressure of not less than 5 psi (34.5 kPa) greater than the pump rating and maintaining such pressure for not less than 15 minutes. The forced sewer shall be water tight at all points.

Reason:

For consistency with P2503.5.1, which requires a 5-foot head test for interior DWV systems. There is no reason for outside drainage piping to be tested differently than inside piping.

Cost Impact

The code change proposal will not increase or decrease the cost of construction .

This is only a change in test pressure. There is no extra labor or extra materials required that would impact the cost of construction.

Internal ID: 274

RP2-18

IRC: P2503.5.1

Proponent: Janine Snyder, City of Thornton, representing Colorado Association of Plumbing & Mechanical Officials (CAPMO) (Janine.Snyder@cityofthornton.net)

2018 International Residential Code

P2503.5.1 Rough plumbing. DWV systems shall be tested on completion of the rough piping installation by water or, for piping systems other than plastic, by air, without evidence of leakage. Either test shall be applied to the drainage system in its entirety or in sections after rough-in piping has been installed, as follows:

1. Water test. Each section shall be filled with water to a point not less than 5-10 feet (~~1524-3048~~ mm) above the highest fitting connection in that section, or to the highest point in the completed system. Water shall be held in the section under test for a period of 15 minutes. The system shall prove leak free by visual inspection.
2. Air test. The portion under test shall be maintained at a gauge pressure of 5 pounds per square inch (psi) (34 kPa) or 10 inches of mercury column (34 kPa). This pressure shall be held without introduction of additional air for a period of 15 minutes.

Reason:

In the 2015 cycle, the IRC was changed to reduce the DWV water test pressure from 10 feet of head to 5 feet of head, yet the air test pressure remains at the equivalent of 10 feet of head or 5 psi. Since it is important enough to maintain the equivalent air test pressure for the 10 feet of head then why are we creating a conflict within the same code section between water and air tests. The DWV material performs in the exact same manner in an IRC building as it does in an IPC building, and the pipe used for DWV systems in an IRC building is the same pipe allowed for use in an IPC building. Furthermore, the integrity of the 10 feet of head test was important enough for the IPC committee to disapprove the reduction in the water test pressure in the 2015 and 2018 codes, so why are we risking a compromise to the IRC structures by allowing a reduced test pressure that allows leaks in the system to go undetected until they cause damage. This code change corrects the conflict between the air and water test within the IRC requirements, and this code change will also address the conflicting test pressures between the IPC and the IRC for the water test.

Cost Impact

The code change proposal will not increase or decrease the cost of construction .

The test is already a requirement within the code and a change in test pressure doesn't impact labor or materials.

Internal ID: 2378

RP3-18

IRC: P2705.1, P2708.6 (New), P2713.4 (New), SECTION P2726 (New), P2726.1 (New), P2726.2 (New), P2726.2.1 (New), P2726.2.2 (New), P2726.3 (New), P2726.4 (New), P2726.4.1 (New), P2726.4.2 (New), P2726.4.3 (New), P2726.5 (New), P2726.6 (New)

Proponent: Jake Pauls, representing Jake Pauls Consulting Services (bldguse@aol.com)

2018 International Residential Code

Revise as follows:

P2705.1 General. The installation of fixtures shall conform to the following:

1. Floor-outlet or floor-mounted fixtures shall be secured to the drainage connection and to the floor, where so designed, by screws, bolts, washers, nuts and similar fasteners of copper, copper alloy or other corrosion-resistant material.
2. Wall-hung fixtures shall be rigidly supported so that strain is not transmitted to the plumbing system.
3. Where fixtures come in contact with walls and floors, the contact area shall be water tight.
4. Plumbing fixtures shall be usable including safety of users of showers, bathtubs and bathtub-shower combinations in accordance with R301.1, R306, R307, R308, R311, R320, P2701, P2708, P2713, and P2726.
5. Water closets, lavatories and bidets. A water closet, lavatory or bidet shall not be set closer than 15 inches (381 mm) from its center to any side wall, partition or vanity or closer than 30 inches (762 mm) center-to-center between adjacent fixtures. There shall be a clearance of not less than 21 inches (533 mm) in front of a water closet, lavatory or bidet to any wall, fixture or door.
6. The location of piping, fixtures or equipment shall not interfere with the operation of windows or doors.
7. In flood hazard areas as established by Table R301.2(1), plumbing fixtures shall be located or installed in accordance with Section R322.1.6.
8. Integral fixture-fitting mounting surfaces on manufactured plumbing fixtures or plumbing fixtures constructed on site, shall meet the design requirements of ASME A112.19.2/CSA B45.1 or ASME A112.19.3/CSA B45.4.

Add new text as follows:

P2708.6 Grab Bars and Stanchions for Showers and Bathtub-Shower Combinations. Showers and bathtub-shower combinations shall provide stanchions or similar vertically-oriented, handholds typically not attached to walls, and grab bars in accordance with P2726.

P2713.4 Grab Bars and Stanchions for Bathtubs and Bathtub-Shower Combinations. Bathtubs and bathtub-shower combinations shall provide grab bars or stanchions in accordance with P2726.

SECTION P2726 GRAB BARS FOR BATHTUBS AND SHOWERS.

P2726.1 General. Grab Bars and Stanchions for Bathtubs, Bathtub-Shower Combinations, and Showers. Bathtubs, bathtub-shower combinations, and showers not required to be accessible shall be provided with grab bars or stanchions complying with P2726.1 through P2726.6. Dimensions specified are to the centerline of the grab bar or stanchion.

P2726.2 Grab Bars or Stanchions for Bathtubs and Bathtub-Showers. Grab bars or stanchions complying with P2726.2.1 and P2726.2.2 shall be provided at bathtubs and bathtub-shower combinations.

P2726.2.1 Vertical Grab bar or Stanchion. A vertical grab bar or stanchion shall be provided and shall comply with the following criteria.

1. Approach. The grab bar or stanchion shall be located so that it is usable without any obstruction. An unobstructed clear floor space 21 inches (533 mm) wide minimum and 21 inches (533 mm) deep minimum, measured from the outer side of the bathtub, shall be provided and shall be located within 12 inches (305 mm) of the grab bar or stanchion.

2. Length. The grab bar or stanchion shall be 36 inches (914 mm) long minimum.
3. Position. The grab bar or stanchion shall be positioned in accordance with the following criteria:
 - 3.1. The lower end of the grab bar or stanchion shall be 24 inches (610 mm) minimum and 27 inches maximum above the finished floor.
 - 3.2. Grab bars located inside a combination bathtub-shower compartment shall have their centerline 6 inches (152 mm) minimum, measured horizontally, to the shower curtain rod and 8 inches (200 mm) maximum, measured horizontally from the outer side of the bathtub.
 - 3.3. Grab bars and stanchions shall be permitted within 6 inches (152 mm) outside of the outer side of the bathtub complying with P2726.2.1.1

P2726.2.2 Horizontal Grab Bar. A 24-inch (610 mm) long minimum grab bar shall be provided on the long, non-entry side of bathtubs and bathtub-shower combinations. The grab bar shall be installed in a horizontal position and shall be centered, plus or minus two inches, along the length of the tub. The horizontal grab bar shall be located 8 inches (205 mm) minimum and 10 inches (255 mm) maximum above the tub rim.

Exception: A diagonal grab bar or, with 24 inches (610 mm) minimum length is permitted if installed with its higher end 12 inches (305mm) maximum from the control wall. The higher end of the grab bar shall be 25 inches (635 mm) minimum and 27 inches (685 mm) maximum above the tub rim. The lower end shall be located 8 inches (205 mm) minimum and 10 inches (255 mm) maximum above the tub rim.

P2726.3 Vertical Grab Bar or Stanchion for Showers. A vertical grab bar or stanchion shall be provided for showers. The vertical grab bar or stanchion shall be located either interior to or outside the shower compartment, within 3 inches (76 mm) of the compartment access and egress opening. The grab bar or stanchion shall be 24 inches (610 mm) long minimum with its lower end 39 inches (991 mm) maximum above the finished floor.

P2726.4 Other Details. Grab bars and stanchions shall comply with P2726.4

P2726.4.1 Cross Section. Grab bars and stanchions shall be circular in cross section having an outside diameter of 1.25 inches (32 mm) minimum and 2 inches (51 mm) maximum.

P2726.4.2 Spacing. The space between the grab bar or stanchion and adjacent surfaces plus water controls shall be 1.5 inches (32 mm) minimum.

P2726.4.3 Surface Hazards. Grab bars, stanchions and adjacent surfaces shall be free of sharp or abrasive elements. Edges shall be rounded with a minimum radius of 0.25 inch (6 mm).

P2726.5 Structural Characteristics. Allowable stresses shall not be exceeded for materials used when a vertical or horizontal force of 250 pounds (1112 N) is applied at any point on the grab bar, stanchion, fasteners, mounting device or supporting structure. Grab bars and stanchions shall not rotate within their fittings.

P2726.6 Design and Installation for Water. Grab bars, stanchions, fasteners, mounting device or supporting structure shall be designed and installed in accordance with P2701.1, with suitable materials, to withstand effects of water, including corrosion and other deterioration through their service life.

Reason:

“Reason Statement” or Justification for Grab Bars and Stanchions for Bathtubs, Bathtub-Shower Combinations and Showers

Complying with New Requirements in IRC, especially Section P2726

Proposed by Jake Pauls, BArch, CPE, HonDSc

Introduction

Points of Control. Grab bars, handrails and stanchions are important building components providing—in combination with our hands and our feet—what are called (in ergonomics) “points of control” to maintain balance and aid in ambulation and other movement activities that are crucial to utilizing means of egress for safety generally (in both normal and emergency conditions) and which pose dangers of injurious falls, the leading source of injuries in most countries, including the USA.

A brief digression to explain “stanchions.” You see them routinely on transportation vehicles such as subway trains and city buses. They are the **vertical** assemblies of graspable tubing that are fixed between ceilings, horizontal handrails just above head height, seats, floors, etc. usually located between seating and passageways or aisles. The term,

stanchions is used in ADA requirements for transportation vehicles and for this context Wikipedia has the following description: “On board most buses and trams/subways, vertical supports to provide stability when passengers are standing. They are located throughout most city buses and are connected to seats, floor, roof, etc.” This term is used in contexts similar to those for the “poles” referred to in NFPA’s recent adoption of new requirements for grab bars or poles for new bathtubs, bathtub-shower combinations and showers.

Examples of Points of Control in Specific Contexts. The starred, central cell of Table 1. shows the equity, with points of control—**shown in bold italics**—achieved with now-proposed grab bars, handrails and stanchions being required, in Section 1003, in the same way that handrails are required for stairs in the rest of the IBC.

Table 1. Minimum Number of Points of Control Provided with New (★) or Currently Imposed Rules or Practices

Number of Points of Control Via Hands or Feet	≤1	1	2	3	3-4
Standard walker for older adult with altered gait.					✓
Occupational settings with risk of worker falls from heights. Also, stairs where users can use two handrails simultaneously, one on each side.				✓	
Stairs where users have only a single handrail. <i>Grab bar(s) usable for bathtub/shower entry/egress.</i>			✓ ★		
Bathtubs/showers with slip resistant underfoot surfaces when wet.		✓			
Bathtubs/showers without slip resistant underfoot surfaces when wet, the common condition currently.	✓				

The Problems To Be Solved with A New Requirement for Grab bars, handrails and stanchions. The central and most important point of this code change proposal is to respond to the relatively high risk of injurious falls when entering and exiting bathing/showering facilities, in all new settings where they occur. Such risks exceed those for stairs on an exposure-adjusted basis. That is, the time during which one is stepping into or out of a bathtub or shower is more risky than a similar stepping behavior on a stair. The former result in about 25 percent of the injuries as do falls on stairs. This is based on about 300,000 US hospital emergency room visits per year for bathtubs and showers versus about 1.2 million US hospital emergency room visits per year for stairs, using comparably serious injury data for 2010 (discussed by Lawrence, et al., 2015 in the journal Injury Prevention). The societal cost of these injuries, plus about two and a half times additional, medically treated injuries, was (for 2010) about 20 billion dollars for US bathtubs and showers and about 93 billion dollars for US stairs with the greatest risk for both being in homes, where bathing/showering is a near daily activity for most people in the US (Lawrence, et al, 2015). (See also the annex to this justification for details of injuries documented by the US Consumer Product Safety Commission, CPSC.)

Table 1 depicts the current inequity as well as the increased equity that will be achieved when bathtubs and showers are subject to the same principle about availability of points of control (usable by ones hands or feet) that are crucial to our stability in utilizing those portions of the means of egress that entail elevation differences, changes of slope, and changes in slip resistance. The current—at best—one point of control provided with typical bathtubs and showers (i.e., one foot in a stable placement on a slip-resistant surface) would be augmented by one point of control available reliably to one hand. This achieves equity of safety with stairs where we can count on one foot planted on a tread and one hand on a handrail. For some situations, involving bathtubs used for immersion bathing (with occupants seated or lying on the bottom of the tub) two points of control, utilizing grab bars, handrails or stanchions—one for each hand—are needed for this equity and, more practically, to accomplish the relatively difficult stand-to-sit and sit-to-stand transfers within the tub.

Size of the Problem with Bathtubs and Showers Compared to Other Large Problems. Figure 1, a pie chart, shows the approximate scales of the nonfatal injury problem for three dangers to building occupants. In the US, the traditional danger of fire-related injuries is far smaller than that from bathing/showering and even smaller in relation to stair-related injuries. Right now, in the I-Codes, the segment for bathing/showering is not addressed while many, many pages of the I-Codes deal with fire-related injury prevention. Again, the proposal for grab bars and other points of control to be provided equitably, will provide a major improvement to injury prevention that, heretofore, has been largely ignored in code development and in practice except in some hotel properties where no more than half of the grab bars, handrails or stanchions to be required under the new proposal are provided for bathtubs.

Figure 1. Comparing three dangers resulting in injuries in buildings

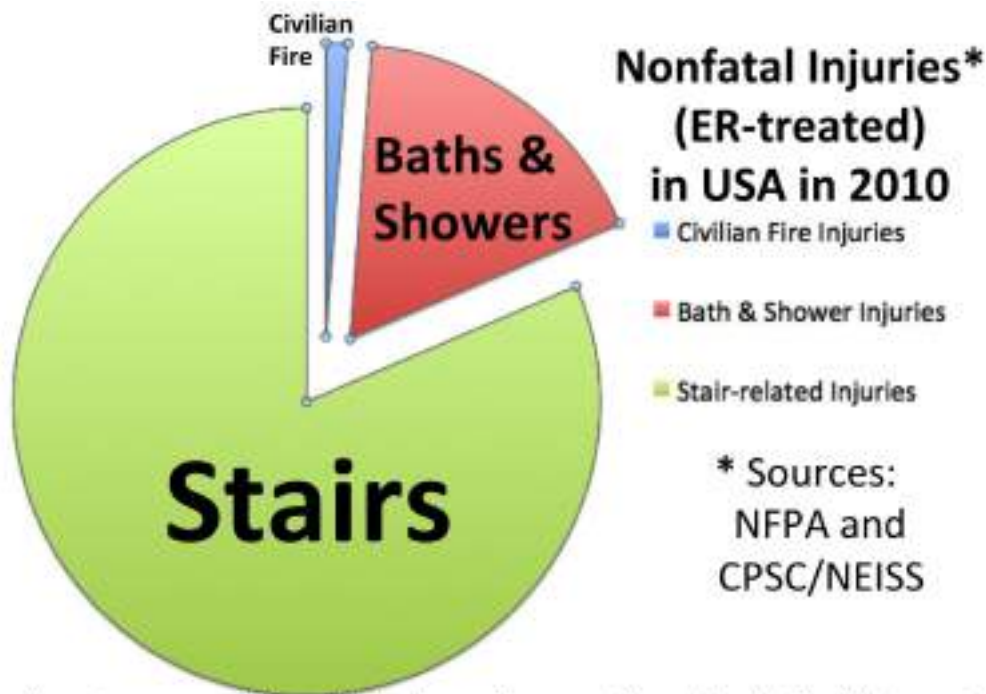

There is an inverse relationship between these epidemiological insights and the extent of coverage of the great dangers of stairs and baths/showers in building codes and housing codes plus leading healthy homes literature.

International Codes, Scientific/Technical/Policy/Managerial Perspectives

Precedent Set by NFPA Codes. The foregoing is the philosophical and epidemiological foundation for the proposed addition of requirements for grab bars, handrails and stanchions in Section 1003 of the IBC and, in future or elsewhere, in the I-Codes generally. There is also the precedent taken in NFPA 101 and NFPA 5000 in their 2018 editions where grab bars (alternatively poles which are given the more-technical name “stanchions” in this IBC proposal) were proposed and almost completely adopted (with the exception of health care, discussed below) for new bathtubs and showers in buildings regulated by these codes. The new requirements were mostly noncontroversial and it is hoped that the same will be true with the proposals now submitted to the I-Codes. The justification for the new requirements far outweigh the opposition to them as the ergonomic, biomechanics, epidemiological, etiological and economic aspects have been carefully considered and addressed to the satisfaction of many people who know building codes and safety standards well and whose votes on the many committees considering the issue attest to the multiple justifications for this new feature of building codes and safety standards.

Parallel Code Development Activity in Canada. A proposal, comparable to what NFPA has adopted, is being addressed by a Grab Bar Task Group for the National Building Code of Canada and, when its next cycle commences, will also be proposed for action by the ICC A117 Committee for a new section, on mainstreamed grab bar, handrail and stanchion features for the A117.1 standard. Leaders in the standards and codes field, conversant with the value of grab bars, handrails and stanchions have been discussing such mainstreaming since early 2016, at an international meeting of experts on bathing/showering safety held in Toronto and partly available for study in a free streaming video that is available with several other streaming videos addressing points of control, grab bars, cost-benefit issues, etc., that are all listed in the Bibliography provided with this proposal. So a lot of the groundwork has been laid and different perspectives have been elicited and discussed.

Survey of Existing Facilities. Centered on hotels, health care facilities**, airport airline club shower facilities*, and homes, the proponent for this code change has been conducting a personal, opportunity-based survey of bathing/showering facilities worldwide, including the following countries where his work on building use and safety has taken him in recent years or his work is followed by other professionals, including public health authorities.

- Canada**
- USA* **
- UK*

- Sweden**
- Finland
- Netherlands
- Italy
- Singapore*
- Australia**
- New Zealand
- Japan

The survey is documented in many hours of video and thousands of photographs plus many measurements, in residential occupancies, of three-, four-, five-piece bathrooms ranging in size from a few square meters (20 square feet) to spaces big enough to park an automobile, occasionally with tubs and showers almost that big. Generally, the more compact the bathroom, the easier it is to provide the needed points of control—and with very substantial cost savings.

Hotels Surveyed. They were operated by Marriott, Sheraton, Intercontinental, Holiday Inn, Best Western, Hyatt, Hilton in almost of the countries listed above. In some of them, meetings were held with hotel managers and those responsible for risk management.

Detailed Justifications for Specific New Sections in IRC

P2705.1 already has the heart of the proposal in its item 4, “Plumbing fixtures shall be usable.” The proposal simply fleshes this out with sufficient detail to implement this objective.

P2708. The new text, for the Section for Showers, clarifies, for Showers, that stanchions (sometimes termed “poles,” as in NFPA’s requirements) are equivalent to required grab bars of the conventional sort. It directs IRC users to a new P2726 for requirements.

P2713. 4. The new text, for the section on Bathtubs, directs users to a new P2726 for requirements.

P2726.1. This new text introduces the detailed requirements and clarifies that dimensions (taken at right angles to the grab bar or stanchion) are to the centerline of the device.

P2726.2. These detailed requirements, here for vertical points of control, are based on research findings and recommendations described below and are roughly similar to what NFPA adopted for the 2018 edition of NFPA 101 and NFPA 5000. They are also being considered currently for the National Building Code of Canada.

In these detailed requirements for the vertical points of control, the first thing is to establish where within the plan of the bathroom, they will adequately serve users. This is based on Section R307 of the IRC which, along with Figure R307.1, sets the required minimum 21-inch (533 mm) clearances in front of fixtures (toilet, lavatory and tub), the areas through which bathers need to move reasonably unobstructed to access the tub and to exit the tub. The required points of control have to be within 12 inches (905 mm), measured horizontally, of these clear areas.

The dimensions shown here, plus the general superiority of vertical grab bars for ambulatory transfers, are based on extensive Canadian research over the last two decades as well as a meeting of US and Canadian experts in early 2016 that is partially available—for its presentations of Principal Investigators—on free steaming video (with links also provided in the Bibliography). An example of a vertical pole that is recognized as at least equivalent to the conventional vertical grab bar is shown in Figure 2, above, along with relevant discussion that supports the superiority of a properly installed stanchion which can be more easily positioned where the tub is most likely to be accessed. These dimensions are generally similar to what NFPA adopted for its 2018 editions of NFPA 101 and NFPA 5000. They are stated slightly differently in the IBC proposal to take better account of bathtubs that do not have walls on one to three sides. As in the NFPA-adopted requirements, P2726.2.1.3(2) addresses the often-missed issue of a wall-mounted conventional, vertical grab bar interfering with the shower curtain getting a good seal on the end wall.

Figure 2. Demonstration set up of both conventional grab bars (nominally meeting the length and location criteria of proposed IRC requirements and a stanchion plus a horizontally-fixed section—like a handrail—of the same tubing used for the stanchion (both completely meeting the length, location and structural strength requirements of proposed IRC requirements (which are consistent with IBC, ICC A117.1 and NFPA requirements)



Besides aesthetic advantages, the stanchion and the full-tub-length bars /tubing are clearly superior in placement flexibility—as they do not require walls for attachment—and better performance for a wider range of users and uses including here, especially for the stanchion, serving a use that is not addressed in P2726 for stand-to-sit and sit-to-stand transfers for toilet users that might be a bonus benefit used more frequently than would be uses related to bathing and showering. This is especially the case in small, residential-use bathrooms such as serving dwellings, where (for space and plumbing efficiency reasons) often have bathtubs and toilets in close proximity. This is addressed further in the Cost Impact section of the justification.

Note that the straight tubing based stanchion and the horizontal bar/tubing are not held by mere compression fit; they are held by adhesive that is permanent and waterproof. The lower part of the stanchion was tested at sustained loads of 300 pounds of horizontal, shearing force without any indication of failure. Its fixing plate shear area exceeds the shear area of conventional grab bar screws by a factor of six and unlike the case for conventional grab bar screws there is no issue with water intrusion and corrosion as well as deterioration of the structural backing for the screws. (See the section below describing field observations of serious deterioration of conventional grab bars fixing details that are often not designed for water intrusion.) Here it should be noted that automobiles, today, utilize high-performance adhesives where, in the past, screws were the norm but these, and the necessary perforations in parts, performed poorly from a corrosion perspective. Water pumps as well as body panels and headlamp plus taillight assemblies are examples of how modern automobiles are built with waterproof, automotive-grade adhesives. Examples of greater use of modern adhesives are also found increasingly in building construction.

Here it must be emphasized that grab bars and stanchions have to be structurally installed; some of the products available in the marketplace, e.g., suction-cup grab bars—that have a temporary and precarious adhesion to smooth tiles—and compression-fit (via a jackscrew mechanism) temporary transfer poles do not meet the structural requirements imposed in the proposed new requirements, the same structural performance requirements applied—withstanding loads of 250 pounds—currently applicable to conventional grab bars in the IBC. In Figure 2, below, the photograph shows a demonstration bathtub-shower combination with a redundant set of both conventional (vertical and diagonal) grab bars and (vertical and horizontal, straight lengths of tubing fixed at their ends)—the latter easily meet the 250-pound structural load criterion.

P2726.2.2 Horizontal Grab Bar. As with the vertical grab bar, described above (for P2726.2.1), the dimensions and

need for this second grab bar are based on Canadian research identified in the Bibliography and is addressed in the video of the presentation by Dr. Nancy Edwards, Principal Investigator of the early Canadian work which also addressed the option of a diagonal grab bar provided via the exception to 2726.2. Note that the base requirement covers installations where the bathtub is not enclosed on one or more sides with a wall. Such horizontal grab bars are intended for use by persons using the tub for immersion bathing which requires stand-to-sit and sit-to-stand transfers that utilize a horizontal or diagonal grab bar (and might also utilize a vertical grab bar or pole addressed by 27.2.1). 2726.2.2 permits horizontal handrails, which could be the same tubing used for the stanchion, to be used in a horizontal orientation. These could be longer (e.g., full tub length) than conventional, horizontal grab bars which need a parallel wall for support, unlike the horizontal tubing fixed between end walls only.

P2726.2.3. Vertical Grab Bar or Stanchion for Showers. Because of the variety of dedicated showers, especially in plan shape and size, this requirement is stated in a relatively flexible fashion relying more on a performance approach than specific dimensions, other than the minimum length and lower end position that takes into account various statures of users as well as the possibility there might be a seat in the shower. The inclusion of a stanchion takes into account the structural differences between bathtubs and free-standing showers; the latter would be good candidates for a stanchion positioned between the ceiling and the floor just outside the shower entrance.

2726.4. Other Details. Generally the requirements referenced here are based mostly on current requirements of ICC A117.1-2017 and with a new provision that addresses often-seen issues of water damage to conventional grab bars that range from the cosmetic to the catastrophic.

27.26.4.1 Cross Section. This is the same as ICC A117.1-2017 without an exception for noncircular sections which are rarely seen within bathrooms.

P2726.4.2. Spacing. This is based on a simplified version of ICC A117.1-2017.

P2726.4.3. Surface Hazards. This expands on a requirement, P2701.1.

P2726.5. Structural Characteristics. This is based on current requirements of ICC A117.1

2726.6. Design and Installation for Water. This last section is new and it addresses a serious problem with a non-trivial number of grab bars that have been seen in hotels, especially in the USA and Canada. Many are not designed, installed and maintained to address deterioration and corrosion problems with conventional, wall-mounted grab bars due to easy water intrusion and entrapment between conventional grab bar mounting plates and the covers fastened over them. Often, when water is entrapped here, there is no way for it to drain out, particularly from the lower portion of the enclosed space.

Problems Found in the Field with Conventional Grab Bars

Here follows some detail on what has been observed in the field on two large problems addressed in 2726.6 as well as in 2726.2.1.3(2).

During the course of his opportunity-based survey of grab bars provided for bathrooms in hotel guest rooms the proponent of this code change has found two problems with many installations.

The first, affecting over 50 percent of the surveyed bathtub-shower combinations, comes from placement of vertical grab bars underneath—and within a few inches horizontally of the end bracket for shower curtains. This makes sealing the shower curtain against the end wall of the bathtub-shower combination very difficult so that the danger of water getting outside the bathtub, on the adjacent floor is heightened unreasonably and needlessly. The proposed section 1003.8.2.1.3(3) addresses this problem as follows: “If attached to a wall, a grab bar or handrail shall be located inside the bathtub or combination bathtub-shower compartment and shall be no closer than 6 inches (152 mm), measured horizontally to the shower curtain rod.”

A much more worrying problem is found with a smaller percentage of conventional, wall-mounted grab bar installations, specifically grab bars which have cover plates over the screw plate onto which the tube of the grab bar is welded. There is invariably a space between the hole in the cover plate through which the tubing (grasped) portion of the grab bar passes and the tubing itself. Water can easily enter here and get trapped by the cover plate thus creating a pool of water and debris (hair, shampoo residue, etc.) from the showering process.

Aside from the hygiene problem here, there is a greatly heightened risk of two structural problems. One is water intrusion into the wall, around the fixing screws—typically two or three for each end of the grab bar, causing deterioration of the backing material so the screws become loose enough to be extractable with ones fingers. The second problem is equally worrisome especially as the quality of the steel used in (off-shore) grab bars is relatively poor in terms of corrosion of the screws and, less often, the mounting plates. The worst case seen recently had the heads of all the screws holding a grab bar so corroded that their heads were completely deteriorated and the grab bar could be pulled away from the walls with little force by one hand—clearly far, far less than the stipulated load of 250 pounds that codes in the US stipulate for structural strength.

The proponent has many photographs of these problems as well as a few videos showing how loose the grab bars have become due to corrosion as well as backing deterioration from water. One such photograph is provided in Figure

3, below; it is not the worst situation seen in the field.

Figure 3. Corrosion behind grab bar cover plate



Clearly such examples need to be addressed in several ways including stronger inspection by authorities and improved management of facilities. Improved design and manufacture of conventional grab bars would help too but, until that occurs, this proposal offers the stanchion options as well as mounting locations that keep the important “points of control” in relatively dry locations, for example at the exterior of a shower enclosure, but still near enough to the entrance to be usable from both outside and inside the enclosure. Proposed Section 2726.2.3 contains the provision, for the grab bar or stanchion to be located either interior to or outside of the shower compartment. . . .

Annexes

Annex 1: Representative sample of narratives of actual bathtub/shower-related injuries that led to US hospital emergency department visits, and for about one in ten of such visits led to hospital admission, **Annex 2**, (plus an additional 30 percent who went directly to hospital admission without an ED visit) in 2010. These are collected and published by the US Consumer Product Safety Commission (CPSC) National Electronic Injury Surveillance System (NEISS) and many more can be downloaded from the CPSC/NEISS Web site, <https://www.cpsc.gov/Research--Statistics/NEISS-Injury-Data>. Accessed January 8, 2018.

Annex 1: US CPSC NEISS: First 112 Sample Narratives (of 6,946 cases) for Product Code 0611 Injuries in 2010 - ER released w/wo treatment

(Product Code 611 covers bathtubs or showers including fixtures or accessories; excluding enclosures, faucets, spigots and towel racks)

41 YOM FRACTURED A RIB BY SLIPPING IN THE BATHTUB & FALLING AGAINST THE TOILET AT HOME.

53 YOF SUSTAINED A CONTUSION OF A SHIN BY BUMPING IT WHILE SHOWERING AT HOME.

18 YOF SPRAINED HER LOWER BACK BY FALLING IN THE SHOWER AT SCHOOL.

02 YOF SUSTAINED A LACERATION OF THE CHIN BY FALLING IN THE BATHTUB AT HOME.

18 YOF SUSTAINED A HEAD INJURY BY FALLING IN A SHOWER AT HOME.

80 YOM DISLOCATED A HIP BY LIFTING LEG IN SHOWER.

86 YOF SUSTAINED A LACERATION OF THE SCALP BY TRIPPING ON A RUG IN THE SHOWER AT HOME.

71 YOF SUSTAINED A HEAD INJURY BY FALLING FROM TOILET AGAINST THE BATHTUB AT HOME.

68 YOF SPRAINED AN ANKLE BY FALLING IN A SHOWER.
47 YOF FRACTURED A KNEE BY FALLING IN THE SHOWER AT HOME.
02 YOF SUSTAINED A LACERATION OF THE CHIN BY FALLING IN THE BATHTUB.
22 YOM SPRAINED A FOOT WHILE STEPPING OUT OF A SHOWER AT JAIL.
23 YOF SUSTAINED A CONTUSION OF A FOOT BY TRIPPING ON A RUG & STRIKING AGAINST A TUB AT HOME.
40 YOM SUSTAINED A LACERATION OF THE NOSE FROM BEING STRUCK BY THE SHOWER HEAD IN THE SHOWER AT HOME.
21 MOM RUPTURED AN EAR DRUM WITH A COTTON-TIPPED SWAB WHILE BATHING IN TUB AT HOME.
48 YOF SUSTAINED A CONTUSION OF THE NECK BY FALLING IN THE BATHTUB AT HOME.
04 YOF SLIPPED IN BATHTUB FELL AND INJURED FACE DX/ FACIAL LAC L KNEE STR
10 YOF FELL OUT OF SHOWER AND INJURED L KNEE. HAS ABRASION TO KNEE ALSO
80 YOF FELL IN SHOWER AT HOME HIT HEAD. DX/ HEAD INJURY
94 YOM SLIPPED AND FELL IN SHOWER AND HIT FACE ON FLOOR. DX/ FACIAL FX
55 YOM SLL LEG HEMATOMA
72 YOF CAUGHT FOOT IN TUB, INJURING LOWER LEG. NOW HAS HEMATOMA AND INCREASING PAIN.
22 YOF AT HOME FAINTED WHILE IN SHOWER AND FELL CUTTING FOREHEAD.
26 YOF SLIPPED AND FELL IN TUB DX: KNEE STRAIN
90 YOF GETTING OUT OF SHOWER WITH WALKER SLIPPED ON THE FLOOR AND HIT HEAD DX/ SCALP ABRASION
30 YOM SLIPPED AND FELL INTO TUB DX: CONTUSION TO BACK
51 YOF SLIPPED IN TUB AND HIT HEAD DX/ SCALP LAC
60 YOF SLIPPED AND FELL IN TUB DX: CONTUSION TO COCCYX
44 YOM FELL AND HIT ABDOMEN ON BATHTUB AT HOME. DX/ ABDOMINAL CONTUSION
04 YOM WITH CUT TO FACE FELL IN TUB DX: LACERATION TO FACE
51 YOF AT HOME FELL AT 5PM WHEN LOST BALANCE AND HIT L SIDE OF RIBS ON BATHTUB.
33 YOF SLIPPED AND FELL IN TUB DX: HEAD LACERATION
23 MOM FELL IN BATHTUB AT HOME AND HIT CHIN CAUSING LACERATION.
62 YOM WITH BACK PAIN FELL INTO TUB DX; CONTUSION TO LOWER BACK
63 YOF FELL INTO BATHTUB / NO INJURIES OR COMPLAINTS
54 YOM SLIPPED AND FELL IN TUB DX: RIB FRACTURE
02 YOM SLIPPED IN TUB AT HOME AND INJURED FACE DX/ CHIN LAC
25 YOF WITH CHEST PAIN AFTER FALL INTO TUB DX: CONTUSION TO CHEST
84 YOM FELL OUT OF SHOWER ON TO THE FLOOR AT HOME HIT HEAD DX/ HEAD INJURY
85 YOF SLIPPED AND FELL IN TUB AND HIT HEAD AT HOME DX/ HEAD INJURY
06 YOM AT HM WAS TAKING A BATH & SWIMMING IN TUB WHEN HE STRUCK HIS HEAD AGAINST FAUCET CAUSING HEAD LACERATION.
28 YOM AT HOME FELL IN SHOWER. WAS RESPONSIVE PER EMS.
26 YOF SLIPPED / FELL IN THE SHOWER DX: R EAR LAC. / HEAD & R SHOULDER CONTUSION
36 YOF THIS AM SLIPPED WHILE TRYING TO GET OUT OF BATHTUB AND LANDED ON BUTTOCKS.
28 YOF RIPPED FINGER NAIL OFF WHEN SLIPPED IN THE SHOWER AND THE NAIL BENT BACKWARDS.
26 YOF INJURED KNEE STEPPING OUT OF SHOWER DX/ RIGHT KNEE SPRAIN
50 YOM FELL IN BATHTUB AND HIT CHEST DX/ RIB FX
83 YOM CUT SCROTUM FELL IN TUB DX: LACERATION TO SCROTUM
71 YOF FELL OUT OF BATHTUB AT HOME AND HIT HEAD ON THE FLOOR DX/ HEAD INJURY
89 YOF FELL IN TUB HITTING HEAD DX: CLOSED HEAD INJURY
69 YOF WAS IN SHOWER AND FELL BACKWARDS STRIKING HER BACK.
08 YOF AT HOME LACERATED FACE ABOVE R ORBITAL. HIT HER HEAD ON SOAP DISH WHILE SHOWERING. NO LOC.

40 YOM SLIPPED AND FELL IN SHOWER AND INJURED CHEST. DX/ RIB FX
17 YOF FELL IN TUB HURT NECK DX: NECK STRAIN
23 YOM INJURED LOWER BACK BENDING OVER IN SHOWER AT HOME DX/ LUMBAR STRAIN
83 YOF FELL IN THE TUB AT ASSISTED LIVING AND INJURED SHOULDER DX/ RT SHOULDER CONTUSION
02 YOM HIT FACE ON BATHTUB AT HOME DX/ FACIAL LAC
74 YOM FELL AND HIT HEAD IN TUB DX: CONTUSION TO HEAD
85 YOF SLIPPED AND FELL GETTING OUT OF TUB DX: CONTUSION TO HIP
58 YOF SLIPPED AND FELL INTO TUB HIT HEAD DX: CLOSED HEAD INJURY
13 MOM AT HOME FELL IN BATHTUB AND HIT FOREHEAD AND MOUTH.
06 YOM SLIPPED IN BATHTUB AND HIT HEAD DX/ HEAD CONTUSION
78 YOM SLIPPED AND FELL IN TUB DX: LACERATION TO HEAD
08 YOM SLIPPED IN TUB TWISTED ANKLE DX: ANKLE STRAIN
51 YOF HIT HEAD ON SOAP DISH IN SHOWER 2 TIMES THIS WEEK HAS HEADACHE DX/ CONCUSSION
51 YOF SLIPPED IN SHOWER AND INJURED KNEE AT HOME DX/ RIGHT KNEE CONTUSION
83 YOM SLIPPED AND FELL IN THE SHOWER LAST NIGHT AND INJURED BACK DX/ BACK PAIN
31 YOM HIT EYE WITH TOWEL WHILE GETTING OUT OF THE SHOWER AT HOME DX/ RIGHT EYE CORNEAL ABRASION
24 YOF FELL GETTING OUT OF SHOWER HIT HEAD DX/ SCALP LAC
48 YOF SLIPPED IN SHOWER HIT HEAD + LOC DX/ HEAD INJURY
11 YOM SLIPPED IN SHOWER AND INJURED LEG. DX/ LEFT LEG CONTUSION
30 YOF SLIPPED AND FELL INTO TUB DX: CONTUSION TO HIP
18 MOM FELL IN TUB DX: LACERATION TO FACE
46 YOF SLIPPED AND FELL IN TUB DX: CONTUSION TO LOWER BACK
30 YOM CUT HAND ON BROKEN SOAP DISH AT HOME. DX// RIGHT HAND LAC
70 YOF SLIPPED AND FELL IN TUB DX: CONTUSION TO CHEST
31 YOM CUT THUMB ON SHOWER DRAIN THIS AM.
62 YOF SLIPPED IN THE SHOWER AND FELL ON THE FLOOR AT HOME DX/ LEFT WRIST SPRAIN
67 YOM FELL GETTING OUT OF SHOWER HIT HEAD ON TUB AT HOME DX/ SCALP CONTUSION
45 YOF PASSED OUT IN SHOWER AT GROUP HOME HIT HEAD. DX/ HEAD INJURY
04 YOF FELL IN BATHTUB AND HIT MOUTH DX/ LIP LAC
43 YOM SLIPPED IN BATHTUB AND INJURED KNEE DX/ LEFT KNEE CONTUSION
15 YOM TAKING SHOWER AND SHOWER DOOR SHATTERED AND PT FEET WERE CUT WITH THE GLASS AT HOME DX/ BILAT
FOOT LAC
73 YOF AT 9AM TODAY WAS GETTING OUT OF TUB AND SLIPPED AND BUMPED L RIBS ON THE TUB. C/O RIB PAIN.
87 YOF BENT DOWN TO PUT SCALE AWAY FELL AND HIT INTO TUB AT HOME DX/ LEFT HIP CONTUSION22 YOM FELL IN TUB
AT HOME AND INJURED CHEST DX/ RIB FX
40 YOF SLIPPED GETTING OUT OF BATHTUB AND INJURED LOWER BACK DX/ LOW BACK PAIN
34 YOM FELL AND HIT TUB DX: SHOULDER STRAIN
70 YOF SLIPPED FELL HIT CHEST ON SIDE OF TUB DX: CONTUSION TO CHEST
89 YOF SLIPPED AND FELL IN THE SHOWER LAST NIGHT AT NURSING HOME INJURED CHEST DX/ CHEST CONTUSION
44 YOM FELL IN TUB AND HIT CHEST DX.CHEST CONTUSION
36 YOF SLIPPED AND FELL IN TUB DX: LACERATION TO FACE
56 YOM CUT WRIST ON BROKEN SHOWER KNOB AT HOME DX/ LEFT WRIST LAC
88 YOF FELL AT HOME IN SHOWER AND HIT HEAD ON TUB DX/ SCALP CONTUSION
51 YOM SLIPPED AND FELL IN TUB DX: NECK STRAIN
23 YOM FELL IN BATH TUB AND INJURED CHEST DX/ CHEST CONTUSION

59 YOM FELL IN SHOWER AND INJURED SHOULDER DX/ LEFT SHOULDER FX
46 YOM HAD FALL HIT TUB DX: CONTUSION TO FACE
78 YOF FELL AT HOME AND HIT FACE ON BATHTUB DX/ FACIAL CONTUSION
29YOF WITH BACK PAIN AFTER FALL IN TUB DX: LOW BACK STRAIN
31 YOF FELL GETTING OUT OF TUB AT HOME INJURED FLANK DX/ FLANK CONTUSION
72 YOF AT HOME FELL WHEN SLIPPED ON URINE IN BATHROOM AND HIT HEAD ON SIDE OF BATH TUB.
19 YOF SLIPPED AND FELL INTO TUB DX: CONTUSION TO LOWER BACK
08 YOM FELL IN THE SHOWER AT HOME AND HIT EAR DX/ LEFT EAR LAC
62 YOM SLIPPED / FELL IN THE SHOWER. DX: RIB CONTUSION
09 YOF FELL IN TUB AND HIT LIP. DX/ LIP LAC
56 YOF WITH SHOULDER PAIN AFTER USING BATHBRUSH IN SHOWER DX: SHOULDER STRAIN
75 YOF AT HOME FELL OFF HASSOCK APPROX 30 MIN AGO HITTING HEAD AND L ARM ON BATHTUB. DENIES LOC.
62 YOF SLIPPED IN TUB HITTING FOOT DX: CONTUSION TO FOOT
04 YOM SLIPPED IN THE BATHTUB AND HIT CHIN DX/ CHIN LAC
34 YOM FELL IN THE SHOWER AT HOME INJURED BACK DX/ BACK SPRAIN
25 YOF + ETOH BAL 313 FELL IN SHOWER AND HIT HEAD DX/ HEAD CONTUSION

Annex 2: US CPSC NEISS: First 48 Sample Narratives (of 630 cases) for Product Code 0611 Injuries in 2010 - ER treated & Then Admitted to Hospital

(Product Code 611 covers bathtubs or showers including fixtures or accessories; excluding enclosures, faucets, spigots and towel racks)

89 YOF GETTING OUT OF THE SHOWER THE NEXT THING SHE KNEW SHE WAS ON THE FLOOR WITH HEAD AND SHOULDER INJURY; SHOULDER AND HEAD CONTUSION
69 YOM WAS WASHING HIMSELF IN SHOWER, FELL ONTO BLUNT PART OF BATHTUB, IMMEDIATELY HAD PAIN & TROUBLE BREATHING. DX - MULTIPLE RIB FXS
56 YOF SLIPPED IN THE SHOWER AND FELL FORWARD HITTING HER FACE & INJURING HER RT ARM- DX- MECHANICAL FALL W/ FRACTURE RT SHOULDER
78 YOF FAMILY FOUND HER ON THE FLOOR BETWEEN TOILET AND BATHTUB, SHE STATED SHE PASSED OUT WHEN SHE WAS IN SHOWER; SHOULDER INJURY
47 YOM HAD A WET SHEETROCK FALL ON HEAD WHILE IN SHOWER, +LOC, WAS CONFUSED. DX - BLUNT HEAD TRAUMA W/BRIEF LOC
62 YOM HAD A SYNCOPAL TODAY AT HOME IN THE SHOWER INJURING EYE AREA- DX- LACERATION TO FACE(EYE)
78 YOF PRESENT TO ER FROM HOME WHEN SHE WAS TAKING A BATH AND COLLAPSED - DX- CARDIAC ARREST, RESUSCITAED
43 YOM PRESENT TO ER AFTER HE WAS IN THE BATHTUB AND SLIP AND FELL GETTING OUT HITTING HEAD ON FLOOR- DX- BLUNT HEAD TRAUMA
81 YOM PRESENT TO ER AFTER A FALL IN THE SHOWER AT HOME TODAY INJURING THE HEAD AREA- DX- BLUNT HEAD TRAUMA
41 YOM FELL OUT OF SHOWER AT ASSISTED LIVING HOME YESTERDAY ONTO RT SIDE C/O RT HIP & RT LEG PAIN. DX - RT HIP FRACTURE
80 YOF TRYING TO GET OUT OF BATHTUB ACCIDENTLY FELL INJURED LOWER BACK; BACK CONTUSION AND AMBULATORY DYSFUNCTION
92 YOM PRESENT TO ER AFTER A FALL IN BATHTUB THIS MORNING INJURING RT HIP-DX- FRACTURE RT LOWER TRUNK (HIP)
88 YOF PRESENT TO ER AFTER A FAL IN BATH TUB AT SNF INJURING LT HIP- DX - FRACTURE LT LOWER TRUNK (HIP)
88 YOF WAS GETTING OUT OF SHOWER, FELT DIZZY & FELL STRIKING BACK OF HEAD ON FLOOR INJURING LT ARM. DX - SKIN TEAR LACERATION
88 YOF GETTING OUT OF BATHTUB THIS MORNING FELL TRIED TO BRACE HERSELF INJURED SHOULDER; SHOULDER FRACTURE

71 YOF WAS FOUND DOWN BY SON IN BATHTUB AT HOME, HAS INJURY TO LT EYE & FOREHEAD, IS REPETITIVE. DX - BLUNT HEAD TRAUMA, +ETOH

86 YOF LOST BALANCE WHEN SHE TURNED AROUND & FELL INTO BATHTUB C/O LOW BACK PAIN. DX - LOW BACK PAIN, POSS FX VS CONTUSION

80 YOF HUSBAND DID NOT WANT HER SMOKING IN HOUSE, WENT TO BATHROOM STOOD ON THE TOILET, OPENED WINDOW, SLIPPED BETWN TOILET/TUB; PELVIC FX

44 YOF FELL IN SHOWER TODAY SUSTAINING HEAD INJURY. DX - SCALP LACERATION

37 YOF SUSTAINED A MECHANICAL FALL IN SHOWER ONTO RT UPPER EXTREMITY, C/O RT SHOULDER PAIN. DX - RT DISTAL CLAVICLE FX

37 YOM HAD A GROUND LEVEL FALL IN BATHROOM STRIKING LOWER BACK ON BATHTUB. DX - SPINAL CONTUSION

84 YOF HAD SYNCOPAL EPISODE IN SHOWER AND FELL. DX: L 10TH RIB FX, INABILITY TO AMBULATE.

87 YOF FELL IN SHOWER. DX: RHABDOMYOLYSIS.

93 YOF FELL IN SHOWER AT ASSISTED LIVING. DX: L DISTAL HUMERUS FX.

79 YOM FELL IN SHOWER. DX: A FIB W/RAPID VENTRICULAR RESP, SYNCOPE, SDH, SAH, ELEVATED INR.

84 YOF FELL WHILE GETTING OUT OF BATHTUB SUSTAINING A FRACTURE TO HER LUMBAR SPINE

90 YOF SLIPPED IN BATHTUB AND GRAZED HEAD ON SHELF AT ASSISTED LIVING. DX: R KNEE STRAIN W/POSS INTERNAL DERANGEMENT, CLOSED HEAD INJURY.

82 YOF WITH NO INJ FROM FALL IN TUB

85 YOM WITH NO IN, FELL IN BATHTUB, ADMITTED FOR OTHER REASONS

52 YOM W/ALS FELL AND BECAME STUCK BETWEEN TOILET AND TUB. DX: RHABDOMYOLYSIS STATUS POST FALL, NASAL FX.

95 YOF FELL IN SHOWER SUSTAINING CHEST CONTUSION

71 YOF SLIPPED AND FELL IN SHOWER. DX: SYNCOPE, LARGE HEAD LAC, COAGULOPATHY, HYPOKALEMIA, LONT QT, ALCO

79 YOF FELL IN SHOWER SUSTAINING A FRACTURED KNEE

87 YOF WITH RIB FRACTURE FROM FALL IN TUB

79 YOM WITH LOWER BACK STRAIN FROM FALL IN SHOWER

81 YOF TURNED IN SHOWER AND FELL SUSTAINING A FRACTURED HIP

97 YOF FELL IN THE SHOWER AT NURSING HOME. DX: TRAUMATIC SDH, AGGITATION.

70 YOF FELL IN SHOWER AT HOME AND WAS UNABLE TO GET UP, SUSTAINED CHI, BACK CONTUSIONS

88 YOF FELL AGAINST BATHTUB AND WALL AT ASSISTED LIVING. DX: BACK/SHOUL PX, SYNCOPE, STAGE I THORACIC DECUBITUS ULCER, MULT OLD THORACIC FX'S.

88 YOF SLIPPED ON WET FLOOR GETTING OUT OF SHOWER AT NURSING HOME. DX: BACK CONT, PNEUMONIA, HYPOXEMIA, PLEURAL EFFUSION.

41YOF WITH NO INJURIES FROM FALL IN SHOWER, WAS ADMITTED

83 YOM FELL IN THE SHOWER. DX: TRAUMATIC ICH, FACIAL LAC, CONCUSSION W/O LOC, RENAL FAILURE.

94 YOM FELL GETTING OUT OF THE SHOWER AND HIT HEAD SUSTAINING A LACERATION

79 YOM FELL ON SIDE OF BATHTUB. DX: SYNCOPE, CHEST WALL CONT.

55 YOM SLIPPED AND FELL IN BATHTUB. DX: R HEMOTHORAX/PNEUMOTHORAX, MULT R RIB FX'S.

86 YOF FELL BACKWARDS INTO BATHTUB & HIT HEAD AT HOME DX: LACERATION TO SCALP/ ACUTE DEHYDRATED

95 YOF TRIPPED OVER THROW RUG WHILE GETTING INTO SHOWER AT HOME DX; AVULSION TO FACE/ MALIGNANT HYPERTENSION

53 YOF SLIPPED IN SHOWER AND FELL HITTING HIP ON TOILET AT HOME DX: STRAINED RIGHT HIP/ UNCONTROLABLE DIABETES

Bibliography:

Bibliography

Approximately 50 internationally-produced scientific and technical references, on bathing/showering safety, were

compiled by the proponent, in 2016, for an American Public Health Association (APHA) draft policy highlighting, especially two Canadian research studies that also are addressed in video presentations by Principal Investigators (Dr. Nancy Edwards, Dr. Alison Novak) for the research and posted, for free streaming viewing at, <https://vimeo.com/164239941> Accessed January 8, 2018. Additional videos covering technical aspects of bathing and showering safety (including cost impact and benefit issues*) are found at the following links (all of which are available, with descriptions, at www.bldguse.com, the proponent's Professional Practice Website, Accessed January 8, 2018.).

- <https://vimeo.com/237294479>
- <https://vimeo.com/239276202> *
- <https://vimeo.com/197742277>
- <https://vimeo.com/193507768>
- <https://vimeo.com/173883358>
- <https://vimeo.com/175101448> *
- <https://vimeo.com/117572176>

Bibliography Entries. The draft policy statement, for APHA consideration in 2016, was titled, “Improving Fall Safety and Related Usability of Bathrooms within Buildings through Safety Standards, Building Codes, Housing Codes and Other Mechanisms.” (The numbers shown for this bibliography—in connection with the ICC code change proposal—are those used in the 2016 draft policy.)

Note that, given the source and the fairly standard format for scientific papers, this format departs from the suggested ICC format and logistics prevent converting the following to the ICC format.

1. Edwards N, Birkett N, Nair R, et al. Access to bathtub grab bars: evidence of a policy gap. *Can J Aging* 2006;25:295-304.
2. Chauvin J, Pauls J, Strobl L. Building Codes: an often overlooked determinant of health. *J. Public Health Policy* 2016;37(2):136-48.
3. Centers for Disease Control and Prevention. Nonfatal Bathroom Injuries Among Persons Aged ≥ 15 Years United States, 2008. *MMWR* 2011;60:729-33.
4. Lockett D, Aminzadeh F, Edwards N. Development and evaluation of an instrument to measure seniors' attitudes toward the use of bathroom grab bars. *Public Health Nurs* 2002;19:390-397.
5. Aminzadeh F, Edwards N, Lockett D, Nair RC. Utilization of bathroom safety devices, patterns of bathing and toileting, and bathroom falls in a sample of community living older adults. *Technology and Disability* 2000;13:95-103.
6. Kira A. *The Bathroom*. New and Expanded Edition, The Viking Press, New York, 1976.
7. Lawrence B, Spicer R, Miller T. A fresh look at the costs of non-fatal consumer product injuries. *Injury Prevention* 2015;21:23-9.
8. US CPSC NEISS. National Electronic Injury Surveillance System (NEISS). US Consumer Product Safety Commission. Available at: www.cpsc.gov/en/Research--Statistics/NEISS-Injury-Data/ Accessed August 8, 2016.
9. Cote R. Grab Hold: Considering grab bars to prevent falls in baths and showers. *NFPA Journal*, November-December 2015. Available at: <http://www.nfpa.org/newsandpublications/nfpa-journal/2015/november-december-2015/in-compliance/nfpa-1>. Accessed August 8, 2016.
10. Mao SJ, McKenzie LB, Xiang H, Smith, GA. Injuries associated with bathtubs and showers among children in the United States *Pediatrics* August 2009;124(2):541-7.
11. Stone RF, Blackwell D, Burton DJ. A systematic program to reduce the incidence and severity of bathtub and shower area injuries. US Consumer Product Safety Commission Contract No.: CPSC-P-74-334, Report. Cambridge, MA: Abt Associates, 1975. Available at: www.cpsc.gov/pagefiles/93711/os1b.pdf Accessed August 9, 2016.
12. Lawrence B, Miller T, Jensen A, et al. Estimating the costs of non-fatal consumer product injuries in the United States. *Inj Control Saf Promot* 2000;7:97-113.
13. Queensland Injury Surveillance Unit. Bathroom injuries in Queensland. *Injury Bulletin* 2006;91. Available at: www.qisu.org.au/ModCoreFilesUploaded/Bulletin_9198.pdf. Accessed August 10, 2016.
14. Professional Education, American Geriatrics Society. Summary of the Updated American Geriatrics Society/British Geriatrics Society Clinical Practice Guideline for Prevention of Falls in Older Persons *J Am Geriatr Soc* 2011 Jan;59(1):148-57. Available at: <http://www.ncbi.nlm.nih.gov/pubmed/21226685> accessed August 10, 2016.
15. Tinetti ME, Speechley M, Ginter SF. Risk factors for falls among elderly persons living in the community. *New England Journal of Medicine* 1988;319(26): 1701-07.

16. Shields W, McDonald E, Frattaroli S, et al. Structural housing elements associated with home injuries in children *Inj Prev* 2016;22:105-109.
17. Gill TM, Williams CS, Robinson JT, Tinetti ME. A population-based study of environmental hazards in the homes of older persons. *Am J Public Health* 1998;89:553-6.
18. Gill TM, Williams CS, Tinetti ME. Environmental hazards and the risk of nonsyncopal falls in the homes of community-living older persons. *Med Care* 2000;38:1174-83.
19. Marshall SW, Runyan CW, Yang J, et al. Prevalence of selected risk and protective factors for falls in the home. *Am J Prev Med* 2005;28(1):95-101.
20. Runyan CW, Perkis D, Black C, et al. Unintentional injuries in the home in the United States. Part II: morbidity. *Am J Prev Med* 2005;28:80 -7.
21. Sattin RW, Rodriguez JG, DeVito CA, Wingo PA, Study to Assess Falls Among the Elderly (SAFE) Working Group. Home environmental hazards and the risk of fall injury events among community-dwelling older persons. *J Am Geriatr Soc* 1998;46:669 -76.
22. Lawrence, BA. Revised Incidence Estimates for Nonfatal, Non-Hospitalized Consumer Product Injuries Treated Outside Emergency Departments. Draft Final Report to the U.S. Consumer Product Safety Commission, Task Order 2, Contract CPSC-D-09-0003, April 30, 2013 Available at: <https://www.cpsc.gov/PageFiles/169938/DecisionTree.pdf> Accessed August 14, 2016.
23. Sveistrup H. Patterns of use of different toilet grab bar configurations by community-living older adults Research Highlight (Canada Mortgage and Housing Corporation) 2013.
24. Sveistrup H, Lockett D, Edwards N, Aminzadeh F. Evaluation of bath grab bar placement for older adults. *Technology and Disability* 2006;13(39):1-11.
25. Ellis N. Introduction to Fall Protection. American Society of Safety Engineers, Des Plaines, IL, 2011, 122-3.
26. Novak A, King E. Final Report for National Research Council, Joint Task Group on Grab Bars: Biomechanical investigation of grab bar use and balance control during bathing transfers. Toronto Rehab Institute - University Health Network, Toronto, Canada, 2016
28. Edwards N, Lockett D, Aminzadeh F, Nair RC. Predictors of bath grab-bar use among community living older adults. *Can J Aging* 2002;22:217-27.
29. Sveistrup H, Lockett D, Edwards N, Aminzadeh F. Evaluation of bath grab bar placement for older adults. *Technology and Disability* 2006;13; 1-11
30. Guitard P, Sveistrup H, Edwards N, Lockett D. Use of different bath grab bar configurations following a balance perturbation. *Assistive Technology* 2011;23:205-15
31. Siegmund GP, Flynn J, Mang DW, Chimich DD, Gardiner JC. Utilized friction when entering and exiting a dry and wet bathtub. *Gait & Posture* 2010; 31(4):473-8.
32. Sparrow WA, Shinkfield A, Chow S, Begg RK. Characteristics of gait in stepping over obstacles. *Hum Movement Sci* 1996;15:605-22.
35. U.S. Department of Justice. Americans with Disabilities Act Standards for Accessible Design. 2010 § 607-809. Available at: <http://www.ada.gov/regs2010/2010ADASTandards/2010ADAstandards.htm>. Accessed 08/10/16.
36. U.S. Department of Housing and Urban Development. Fair Housing Design Manual: A manual to assist designers and builders in meeting the accessibility requirements of the Fair Housing Act. Available at: www.huduser.gov/portal/publications/destech/fairhousing.html Accessed 08/10/16.
37. Pacific Institute for Research and Evaluation. Injury Prevention: What works? A Summary of cost-outcome analysis for injury prevention programs. Report prepared for Children's Safety Network. 2014.
38. Gillespie LD, Gillespie WJ, Robertson MC, et al. Interventions for preventing falls in elderly people. *Cochrane Database Syst Rev* 2003;4:CD000 Available at: www.cochranelibrary.com/cochrane-database-of-systematic-reviews/index.html accessed August 10, 2016.
39. Turner S, Arthur G, Lyons RA, et al. Modification of the home environment for the reduction of injuries. *Cochrane Database of Systematic Reviews* 2011, Issue 2. Art. No.: CD003600.
DOI: 10.1002/14651858.CD003600.pub Available at: www.cochranelibrary.com/cochrane-database-of-systematic-reviews/index.html accessed August 10, 2016.
40. Kendrick D, Young B, Mason-Jones AJ, et al. Home safety education and provision of safety equipment for injury prevention. *Cochrane Database of Systematic Reviews* 2012, Issue 9. Art. No.: CD005014. DOI: 10.1002/14651858.CD005014.pub3. Available at: www.cochranelibrary.com/cochrane-database-of-systematic-reviews/index.html

reviews/index.html accessed August 10, 2016.

41. Keall MD, Howden-Chapman P, Baker MG, et al. Formulating a programme of repairs to structural home injury hazards in New Zealand. *Accid Anal Prev* 2013;57:124–
42. Keall MD, Pierse N, Howden-Chapman P, et al. Home modifications to reduce injuries from falls in the Home Injury Prevention Intervention (HIPI) study: a cluster-randomised controlled trial. *Lancet* 2015;385:231–8.
43. Kaniewaki M, Stevens JA, Parker EM, Lee R. An introduction to the Centers for Disease Control and Prevention's efforts to prevent older adult falls. *Front Public Health* 2014;2:119.
44. Stevens JA, Phelan EA. Development of STEADI: A fall prevention resource for health care providers. *Health Promot Pract.* 2013;14(5): 706–714. (See Table 2 where the brochure, Check for Safety, is listed under Patient educational materials.)
45. CDC National Center for Injury Prevention and Control. Check for Safety: A home fall prevention checklist for older adults. US CDC 1999.
46. CDC National Center for Injury Prevention and Control. Check for Safety: A home fall prevention checklist for older adults. US CDC 2016. Available at: www.cdc.gov/steady/patient.html Accessed August 9, 2016.
47. Lunsford B, Wilson LD. Assessing your patients' risk for falling. *American Nursing Today* 2015;10(7). Available at: <https://americannursetoday.com/assessing-patients-risk-falling/> Accessed January 8, 2018.

Other items for the Proposal Bibliography (from post-2016 sources) and one earlier paper specific to (transfer) pole-type grab bars which are included in the IBC proposal.

Novak A, King E. Final Report for National Research Council, Joint Task Group on Grab Bars: Biomechanical investigation of grab bar use and balance control during bathing transfers. Toronto Rehabilitation Institute-University Health Network, 2017.

King EC, Novak AC. Centennial Topics—Effect of bathroom aids and age on balance control during bathing transfers. *American Journal of Occupational Therapy*, 71, 1-9, 2017. Available at <https://doi.org/10.5014/ajot.2017.027136>. Accessed January 8, 2018.

Vena D, Novak AC, King EC, Dutta T, & Fernie GR. The Evaluation of Vertical Pole Configuration and Location on Assisting the Sit-to-Stand Movement in Older Adults with Mobility Limitations. *Assistive Technology* 27, 4, 2015, Available at <http://www.tandfonline.com/doi/full/10.1080/10400435.2015.1030514>. Accessed January 8, 2018. (In referring to sit-to-stand transfers, as from a toilet, this article uses the term, “transfer poles,” to describe the configuration and location of “poles” referred to in the code change proposal.)

Cost Impact

The code change proposal will increase the cost of construction .

Cost Impact

The code change proposal will increase the cost of residential construction, but that increased cost pales in comparison to the benefits of enhanced usability and reduction of fall injuries, the majority of which occur in residential settings, especially homes.

The additional material in the form of conventional grab bars or poles plus their fixings is about 50 dollars per grab bar or pole (using retail prices for the components confirmed as recently as 2017) and with a conventional three-fixture bathroom with a bathtub there would be a need for two such grab bars or poles or one of each. Labor to install these would be about one hour for each. Thus an overall, installed cost is on the order of \$200 per bathroom. The service life would be on the order of two or more decades.

Against this added cost of an installed single grab bar or two per bathroom there are the ongoing benefits of enhanced normal (non-injury) uses which, for a typical US household for a 20-year period, for example, number about 7,000 per person or on the order of 20,000 per household. Those enhanced uses, with grab bars, have an economic value that is larger than the benefit of averted injuries from falls.

Currently without grab bars, our bathtubs and showers are the site of injuries serious enough to require professional medical attention at a rate, annually (using 2010 data) of about 1 million per 110 billion uses or about one in 110,000 uses. Every one of those non-injury uses has a value. By comparison, for stairs this ratio is about one professionally treated fall injury for every million flight uses in home settings and one such injury for every ten million flight uses in public settings where, under the IBC and more-detailed inspection procedures, stairs are nearly one order of magnitude safer than those nominally constructed under the IRC. See the video presentation by Jake Pauls to the April 2017 meeting, “The Impact of Building Codes and Standards in Public Health and Safety,” held in Melbourne, Australia, in connection with the 15th World Congress on Public Health. The streaming video containing this presentation, which

includes the “Injury Pyramids” used for the above stair safety calculation, is available freely at <https://vimeo.com/239276202> (as listed in the first part of the Bibliography accompanying this proposal) accessed Jan 8, 2018.

The injuries-averted benefit, over twenty years, has a value, in 2010 dollars, about 6.5 times greater than the installation cost, based on the very reasonable assumption that half the falls are averted with the specified grab bars or poles. For the vertical poles that also enhance and make safer the use of toilets that, being adjacent to a bathtub, can serve stand-to-sit and sit-to-stand transfers for toileting, this benefit increases by about 35 percent to nearly 9 times greater than the installation cost. These projections are based on the injury economic data provided by the 2015 paper in the respected journal, *Injury Prevention*, by Lawrence, Spicer and Miller (see Bibliography for details).

The bottom line is that the benefits of both enhanced normal uses, in the tens of thousands per household over a 20-year period, combined with the benefit of averted injuries, is on the order of at least 20 or more times the cost of providing the grab bars, especially if they take the form of vertical poles serving bathtub-shower combination users as well as toilet users in a three-piece bathroom provision that is very common in homes and hotels, for example. For hotels, while the lavatory sink(s) may be in a separate space, the toilet and bathtub-shower combination are usually close together so that a single pole can serve transfers for both. Thus the cost impact of grab bar or pole installations is very small in relation to the benefits and that cost of installation is very small in relation to the overall price of a dwelling unit or hotel guest room for example.

Internal ID: 2120

RP4-18

IRC: P2709.4.1 (New)

Proponent: Angel Guzman Rodriguez, ASME, representing The American Society of Mechanical Engineers (ASME)

2018 International Residential Code

Add new text as follows:

P2709.4.1 Waste Fittings. Flanged drains shall conform to ASME A112.18.2/CSA B125.2.

Reason:

Section P2709.4 mentions flanged drain requirements and these drains must be approved but to what standard. The latest version of ASME A112.18.2/CSA B125.2 contains specific requirements for flanged drains. This standard also includes requirements for built up shower drains systems which are normally used in field fabricated shower systems.

Cost Impact

The code change proposal will not increase or decrease the cost of construction .

This proposal only identifies the standard that the industry is already making these waste fittings comply with and be certified to. Thus, there will be no impact to material (or labor) cost because of this added requirement.

Internal ID: 1454

RP5-18

IRC: P2904.2.1

Proponent: Jeffrey Shapiro, representing IRC Fire Sprinkler Coalition (jshapiro@ircfiresprinkler.org)

2018 International Residential Code

Revise as follows:

P2904.2.1 Temperature rating and separation from heat sources. Except as provided for in Section P2904.2.2, sprinklers shall have a temperature rating of not less than 135°F (57°C) and not more than ~~170°F (77°C)~~ 225°F (107°C). Sprinklers shall be separated from heat sources as required by the sprinkler manufacturer's installation instructions.

Reason:

NFPA 13D (Section 7.5.6.1 in the 2016 edition) allows intermediate temperature sprinklers to be used in lieu of ordinary temperature sprinklers in dwelling units, even where elevated ambient temperatures are not expected. So long as the sprinkler used qualifies as a residential sprinkler based on the Response Time Index (RTI) and passing the UL1626 fire test, there is no reason for activation temperature to be limited. Permitting intermediate temperature sprinklers to be used in lieu of ordinary temperature sprinklers can help to avoid the risk of mixing up sprinklers during installation and can ensure that intermediate temperature sprinklers will be present in locations where elevated ambient temperatures may or may not have been anticipated.

Cost Impact

The code change proposal will not increase or decrease the cost of construction .

Residential sprinklers of ordinary or intermediate temperature range are typically the same cost, and this proposal does not require the use of a different sprinkler. It simply allows flexibility.

Internal ID: 1346

RP6-18

IRC: P2904.2.3

Proponent: Jeffrey Shapiro, representing IRC Fire Sprinkler Coalition (jshapiro@ircfiresprinkler.org)

2018 International Residential Code

Revise as follows:

P2904.2.3 Freezing areas. Piping shall be protected from freezing as required by Section P2603.5. or by using a dry pipe automatic sprinkler system that is listed for residential occupancy applications. Where sprinklers are required in areas that are subject to freezing, dry-side-wall or dry-pendent sprinklers extending from a nonfreezing area into a freezing area shall be installed.

Reason:

Listed dry pipe residential sprinkler systems are available, are recognized by NFPA 13D, and are a viable option for freeze protection in lieu of other methods that are currently permitted.

Cost Impact

The code change proposal will not increase or decrease the cost of construction .

Proposal allows an additional alternative to current requirements for freeze protection as an option. There is no mandatory requirement being added.

Internal ID: 1194

RP7-18

IRC: P2904.3.2

Proponent: Jeffrey Shapiro, representing IRC Fire Sprinkler Coalition (jshapiro@ircfiresprinkler.org)

2018 International Residential Code

Revise as follows:

P2904.3.2 Shutoff valves prohibited. With the exception of shutoff valves for the entire water distribution system or a single master control valve for the automatic sprinkler system that is locked in the open position, valves shall not be installed in any location where the valve would isolate piping serving one or more sprinklers.

Reason:

The proposal will correlate with an allowance in NFPA 13D to have a control valve on a standalone sprinkler system. Although NFPA 13D allows such valves to be electronically monitored in lieu of locking, this proposal requires that the valve be locked open, which could be accomplished by simply providing a nylon strap to secure the valve handle. If an owner also wants to electronically monitor the valve, that would be permitted in addition to securing the valve to discourage tampering.

Cost Impact

The code change proposal will not increase or decrease the cost of construction .

The proposal adds an allowance to have a master control valve, but there is no mandate to include one.

Internal ID: 1352

RP8-18

IRC: P2904.4, P2904.4.1, P2904.4.1.1 (New), P2904.4.1.2 (New), P2904.4.1.3 (New), P2904.4.2

Proponent: Jeffrey Shapiro, representing IRC Fire Sprinkler Coalition (jshapiro@ircfiresprinkler.org)

2018 International Residential Code

Revise as follows:

P2904.4 Determining system design flow. ~~The flow for sizing the sprinkler piping system shall be based on the flow rating of each sprinkler in accordance with Section P2904.4.1 and the calculation in accordance with Section P2904.4.2. Sections P2904.4.1 through P2904.4.2.~~

P2904.4.1 Determining required flow rate for each sprinkler. The minimum required flow for each sprinkler shall be determined using the sprinkler manufacturer's published data for the specific sprinkler model based on all of the following:

1. The area of coverage.
2. The ceiling configuration, in accordance with Section P2904.4.1.1 through P2904.4.1.3.
3. The temperature rating.
4. Any additional conditions specified by the sprinkler manufacturer.

Add new text as follows:

P2904.4.1.1 Ceiling configurations. Manufacturer's published flow rates for sprinklers tested under an 8 ft (2.4 m) high ceiling, in accordance with the sprinkler listing, shall be used for the following ceiling configurations, provided that the ceiling surface does not have significant irregularities, lumps or indentations and is continuous in a single plane.

1. Ceilings that are horizontal or that have a slope not exceeding 8 units vertical in 12 units horizontal (67%), without beams, provided that the ceiling height, measured to the highest point, does not exceed 24 ft (7.3 m) above the floor. Where the slope exceeds 2 units vertical in 12 units horizontal (17%), the highest sprinkler installed along the sloped portion of a ceiling shall be positioned above all communicating openings connecting the sloped ceiling compartment with an adjacent space.
2. Ceilings that are horizontal or that have a slope not exceeding 8 units vertical in 12 units horizontal (67%), with beams, provided that the ceiling height, measured to the highest point, does not exceed 24 ft (7.3 m) above the floor. Beams shall not exceed 14 in. (350 mm) in depth, and pendent sprinklers shall be installed under the beams as described at the end of this section. The compartment containing the beamed ceiling shall not exceed 600 ft² (56 m²) in area. Where the slope does not exceed 2 units vertical in 12 units horizontal (17%), the highest sprinkler in the compartment shall be above all communicating openings connecting the compartment with an adjacent space. Where the slope exceeds 2 units vertical in 12 units horizontal (17%) the highest sprinkler installed along the sloped portion of a ceiling shall be positioned above all communicating openings connecting the sloped ceiling compartment with an adjacent space.
3. Ceilings that have a slope exceeding 2 units vertical in 12 units horizontal (17%) but not exceeding 8 units vertical in 12 units horizontal (67%), with beams of any depth, provided that the ceiling height, measured to the highest point, does not exceed 24 ft (7.3 m) above the floor. Sidewall or pendent sprinklers shall be installed in each pocket formed by beams. The compartment containing the sloped, beamed ceiling shall not exceed 600 ft² (56 m²) in area.

Pendent, recessed pendent, and flush-type pendent sprinklers installed directly under a beam having a maximum depth of 14 inches shall have the sprinkler deflector located not less than 1 inch or more than 2 inches below the bottom of the beam. Pendent sprinklers installed adjacent to the bottom of a beam having a maximum depth of 14 inches shall be positioned such that the vertical centerline of the sprinkler is no more than 2 inches from the edge of the beam, with the sprinkler deflector located not less than 1 inch or more than 2 inches below the bottom of the beam. Pendent sprinklers shall also be permitted to be installed less than 1 inch below the bottom of a beam where in accordance with manufacturer's instructions for installation of flush sprinklers.

P2904.4.1.2 Ceiling configurations with special sprinkler listings. For ceiling configurations not specified in Section 2904.4.1.1, the manufacturer's published flow rate for sprinklers that have been listed for protection of such

configurations shall be used.

P2904.4.1.3 Other Ceiling Configurations. For ceiling configurations not addressed by Sections P2904.4.1.1 or P2904.4.1.2, the flow rate shall be subject to approval by the fire code official.

Revise as follows:

P2904.4.2 System design flow rate. The design flow rate for the system shall be based on the following:

1. The design flow rate for a room having only one sprinkler shall be the flow rate required for that sprinkler, as determined by Section P2904.4.1.
2. The design flow rate for a room having two or more sprinklers and a ceiling configuration specified in Section P2904.4.1.1 shall be determined by identifying the sprinkler in that room with the highest required flow rate, based on Section P2904.4.1, and multiplying that flow rate by 2.
3. ~~Where the sprinkler manufacturer specifies different criteria for ceiling configurations that are not smooth, flat and horizontal, the required~~ The design flow rate for that room shall comply with the ~~sprinkler~~ a room having two or more sprinklers and a ceiling configuration covered by Section P2904.4.1.2 shall be in accordance with the manufacturer's instructions.
4. The design flow rate for a room having two or more sprinklers and a ceiling configuration covered by Section P2904.4.1.3 shall be subject to approval by the fire code official.
5. The design flow rate for the sprinkler system shall be the flow required by the room with the largest flow rate, based on Items 1, 2 and 3 through 4.
6. For the purpose of this section, it shall be permissible to reduce the design flow rate for a room by subdividing the space into two or more rooms, where each room is evaluated separately with respect to the required design flow rate. Each room shall be bounded by walls and a ceiling. Openings in walls shall have a lintel not less than 8 inches (203 mm) in depth and each lintel shall form a solid barrier between the ceiling and the top of the opening.

Reason:

These revisions are intended to correlate with NFPA 13D and current installation practices for residential sprinklers protecting spaces with sloped and/or beamed ceilings.

The current Section P2904.4.2 (3) sends the user to the manufacturer's data sheets for special design information related to sloped and/or beamed ceilings, but data sheets for most residential sprinklers no longer provide guidance for these conditions. A 2010 Fire Protection Research Foundation study helped to standardize sprinkler protection criteria for ceilings with slopes and beams by determining that many sloped and beamed ceilings can be sufficiently protected using the same design criteria that apply to horizontal ceilings. This prompted NFPA to add model design criteria to their sprinkler standards and manufacturers are now amending cut sheets to delete criteria for ceiling configurations that are covered by NFPA's standards. Without this revision to Section P2904, the IRC will no longer provide sufficient guidance for protection of sloped or beamed ceilings, and that could be improperly interpreted as only allowing smooth, flat, horizontal ceiling configurations in sprinklered dwellings.

Cost Impact

The code change proposal will decrease the cost of construction .

The sprinkler rules in the IRC, as written, would not allow for sloped ceilings which made the installation of sprinkler systems much more costly than need be.

Internal ID: 421

RP9-18

IRC: TABLE P2904.6.2(2)

Proponent: Jeffrey Shapiro, representing IRC Fire Sprinkler Coalition (jshapiro@ircfiresprinkler.org)

2018 International Residential Code

Revise as follows:

**TABLE P2904.6.2(2)
MINIMUM WATER METER PRESSURE LOSS (PLm)a**

FLOW RATE (gallons per minute, gpm)^b	⁵/₈-INCH METER PRESSURE LOSS (pounds per square inch, psi)	³/₄-INCH METER PRESSURE LESS (pounds per square inch, psi)	1-INCH METER I LOSS (pounds per sq
8	2 <u>3</u>	1 <u>3</u>	1
10	3	1 <u>3</u>	1
12	4	1 <u>3</u>	1
14	5 <u>6</u>	2 <u>5</u>	1
16	7	3 <u>6</u>	1
18	9	4 <u>7</u>	1 <u>2</u>
20	11	4 <u>9</u>	2
22 <u>23</u>	NP <u>14</u>	5 <u>11</u>	2 <u>3</u>
24	NP	5	2
26	NP <u>18</u>	6 <u>14</u>	2 <u>3</u>
28	NP	6	2
30 <u>31</u>	NP <u>26</u>	7 <u>22</u>	2 <u>4</u>
32 <u>39</u>	NP <u>38</u>	7 <u>35</u>	3 <u>6</u>
34	NP	8	3
36 <u>52</u>	NP	8 <u>NP</u>	3 <u>10</u>

For SI: 1 inch = 25.4 mm, 1 pound per square inch = 6.895 kPa, 1 gallon per minute = 0.063 L/s.

NP = Not permitted unless the actual water meter pressure loss is known.

- a. Table P2904.6.2(2) establishes conservative values for water meter pressure loss or installations where the water meter loss is unknown. Where the actual water meter pressure loss is ~~known~~ published and available from the meter manufacturer, P_m shall be the actual loss published pressure loss for the selected meter.
- b. Flow rate from Section P2904.4.2. Add 5 gpm to the flow rate required by Section P2904.4.2 where the water service pipe supplies more than one dwelling.

Reason:

This proposal revises the water meter table in the IRC to better correlate with the water meter table in NFPA 13D, which was updated in the 2013 edition based on research that was published in an Fire Protection Research Foundation Report titled, " Residential Fire Sprinklers - Water Usage and Water Meter performance Study" in 2011. The revised IRC table will include NFPA 13D correlated values for 5/8-inch, 3/4-inch and 1-inch meters, and it retains entries for flows less than 18 gpm, which have been adjusted to reflect findings from the Fire Protection Research Foundation study. NFPA 13D does not include these lesser flows, but the IRC has always included them since low-flow systems are an option for affordable housing. This proposal does not add values for 1 1/2-inch and 2-inch meters, which are included in NFPA 13D, because these meter sizes are excessive and unnecessary for flow demands associated with home fire sprinkler systems. Including them in the table could be taken as a basis of validation for water purveyors looking to justify local requirements for larger, more expensive meters.

Bibliography:

<http://www.nfpa.org/News-and-Research/Fire-statistics-and-reports/Research-reports/Suppression/Residential-Fire-Sprinklers>

Cost Impact

The code change proposal will not increase or decrease the cost of construction .

No expected cost consequences are anticipated to be associated with this proposal in most cases since actual meter pressure loss values are typically available. The prescriptive table values are only included in the code for rare occasions where actual values cannot be ascertained.

Internal ID: 1055

RP10-18

IRC: P2905.3 (New)

Proponent: Anthony Floyd, City of Scottsdale, representing City of Scottsdale (afloyd@scottsdaleaz.gov)

2018 International Residential Code

Add new text as follows:

P2905.3 Hot water supply to fixtures. The developed length of hot water piping, from the source of hot water to the fixtures that require hot water, shall not exceed 50 feet (15 240 mm). Water heaters and recirculating system piping shall be considered to be sources of hot or tempered water.

Reason:

This change adds a new section to limit the hot water supply line length from the source of hot water to the fixtures that require hot or tempered water. This provision is replicated from existing IPC Section 607.2.

Hot water supply lines greater than 50 feet waste water (proportional to pipe size) while occupants wait for hot water to reach fixtures for bathing, washing and culinary purposes. Even though hot water supply lines are insulated, the hot water remaining in the lines between demand periods cools down. Limiting the length and consequent volume of heated water in the supply lines reduce the amount of wasted water and occupant waiting time.

Cost Impact

The code change proposal will not increase or decrease the cost of construction .

Cost is based on proximity of hot water source to point of use.

Internal ID: 552

RP11-18

IRC: P2906.21

Proponent: William Chapin, Professional Code Consulting, LLC, representing Professional Code Consulting, LLC (bill@profcc.us)

2018 International Residential Code

Revise as follows:

P2906.21 Push-fit joints. Push-fit joints shall be used only on copper-tube-size outside diameter dimensioned CPVC, PEX, PE-RT, and copper tubing. Push-fit joints shall conform to ASSE 1061 and shall be installed in accordance with the manufacturer's instructions.

Reason:

Table P2906.6 lists ASSE 1061 fittings as acceptable to be used with polyethylene of raised temperature (PE-RT) plastic tubing. ASSE 1061 does contain testing requirements for use with PE-RT tubing.

Cost Impact

The code change proposal will not increase or decrease the cost of construction .

This proposal is only a clarification as Table P2906.6 already indicates ASSE 1061 fittings for PE-RT tubing.

Internal ID: 1750

RP12-18

IRC: P2909.1, 44

Proponent: Jeremy Brown, NSF International, representing NSF International (brown@nsf.org)

2018 International Residential Code

Revise as follows:

P2909.1 Design.. Drinking water treatment units shall meet the requirements of NSF42, NSF 44, NSF 53, NSF ~~60~~62 or CSA B483.1.

Add new standard(s) follows:

NSF

NSF International
789 N. Dixboro Road
Ann Arbor MI 48105

62-2015:

Drinking Water Distillation Systems

Reason:

The current text of the IRC references an incorrect standard. NSF 60 is Drinking Water Chemicals-Health Effects. This is unrelated to Drinking Water Treatment Units.

The origin of this standard in this code goes back to 2009 when a proposal to add CSA 483.1 also incorrectly added NSF 60. It is believed that the actual intent was to add NSF 62- Drinking Water Distillation Systems.

NSF 62 is an appropriate drinking water treatment technology and this is the American National Standard for this technology. This standard is already referenced in the International Plumbing Code in the corresponding section 611.1 with the same language.

This standard establishes minimum materials, design and construction, and performance requirements for point-of-use and point-of-entry drinking water distillation systems and the components used in these systems. Distillation systems covered by this standard are designed to reduce specific chemical contaminants from potable drinking water supplies. Systems covered under this standard may also be designed to reduce microbiological contaminants, including bacteria, viruses, and cysts, from potable drinking water supplies.

A copy of NSF 62 was submitted with this code change and may be obtained free of charge by anyone considering this code change proposal by emailing brown@nsf.org.

Cost Impact

The code change proposal will not increase or decrease the cost of construction .

This creates an additional option for water treatment but does not mandate the use of this technology so is cost neutral.

Analysis: The referenced standard, NSF 62-2015, is currently referenced in the 2018 IPC-2015 in a section that is coordinate in subject matter to the proposed revised section.

Internal ID: 144

RP13-18

IRC: P3110 (New), P3110.1 (New), P3110.2 (New), P3110.2.1 (New), P3110.3 (New), P3110.3.1 (New), P3110.3.2 (New), P3110.3.3 (New)

Proponent: Jane Malone, American Association of Radon Scientists and Technologists, representing American Association of Radon Scientists and Technologists, National Policy Director

2018 International Residential Code

Add new text as follows:

SECTION P3110 SOIL GAS VENT PIPING

P3110.1 Scope. The provisions of this section shall govern the materials, construction, and installation of soil gas vent pipe and connectors.

P3110.2 Soil gas vent pipe. A gas-tight pipe of 3-inch [76 mm] nominal size or larger shall be extended from below the slab or crawl space through the interior of the building and exit the roof. The pipe shall be centered in a cylindrical space which is located in the attic below the roof, is not adjacent to an eave or wall, and has a vertical height of not less than 48 inches [122 cm] and diameter of not less than 21 inches [53 cm]. Materials used shall comply with Section P3002.

P3110.2.1 Soil gas vent pipe termination. The vent pipe shall terminate vertically upward not less than 12 inches [305 mm] above the roof in a location not less than 10 feet [3048 mm] away from any window, air intake, or other opening into the conditioned spaces of the building that is less than 2 feet [610 mm] below the exhaust point. The vent pipe shall terminate not less than 10 feet [3048 mm] from window or other opening in adjoining or adjacent buildings.

P3110.3 Soil gas vent pipe connector. A tee fitting or equivalent method shall be installed to secure the soil gas vent pipe to the perforated piping or geotextile matting from which soil gas is collected.

P3110.3.1 Crawl spaces. In a building with a crawl space, a soil gas vent pipe connector shall be installed with not less than 10 feet [3048 mm] of perforated pipe or geotextile matting connected to each of the two horizontal openings of the connector. The connector and pipe or geotextile matting shall be located below a soil gas membrane complying with ASTM Class A, B, or C.

P3110.3.2 Slab-on-grade and basements. In buildings with a basement or slab-on-grade, a soil gas vent pipe connector of 4-inch [102 mm] nominal diameter shall be installed with not less than 4 feet [1219 mm] of perforated pipe or geotextile matting connected to each of the two horizontal openings of the connector.

P3110.3.3 Drain tile systems. Where an interior drain tile system is present, the two horizontal openings of the soil gas vent pipe connector shall be connected to the drain tile system.

Reason:

Chapter 31 governs the piping, tubing and fittings for vents in one- and two-family dwellings. Soil gas vents are commonly installed by plumbers yet there is no information about soil gas vents in Chapter 31 or elsewhere in the plumbing sections of the IRC. Sections 401 through 701 of ANSI AARST CCAH-2013, Reducing Radon in New Construction of One and Two Family Dwellings describe the pipe-related (and other) requirements for soil gas vents. This proposed code change concisely adds the standard's requirements for such vents, which will ensure that plumbers have the correct information within the IRC plumbing chapter on vents. This change does not add a requirement to provide a soil gas vent but rather delivers the specification for how to provide one when a building project requires one.

Bibliography:

[ANSI AARST CCAH-2013, Reducing Radon in New Construction of One and Two Family Dwellings] [AARST Consortium on Radon Standards] [2013] [<http://aarst-nrpp.com/wp/america-national-radon-standards/>]

Cost Impact

The code change proposal will not increase or decrease the cost of construction .

The provisions are not required for every home. They only apply to homes where the builder or buyer includes soil gas vent pipe.

Internal ID: 2287

RP14-18

IRC: P2701.4, P2717.2, P3005.3.5, P3201.1, P3201.2, P3201.3 (New), P3201.4, P3201.3.1, P3201.5, P3201.6, P3201.7, Chapter 44

Proponent: Ronald George, representing Wavin Ltd. (Ron@Plumb-TechLLC.com)

2018 International Residential Code

Add new text as follows:

P3201.3 Non-liquid seal devices. Each non-liquid seal, drainage sealing device shall conform to ASME A112.18.8 and shall be an alternative to a liquid seal type trap. Such devices shall be installed only on 1-1/4 inch (31.8mm) and 1-1/2 inch (38.1 mm) tubular drains. Where devices conforming to ASME A112.18.8 are installed on the outlet of food waste disposers, the devices shall be installed in the vertical, downward flow orientation. These devices shall be protected from back pressure by one of the same approved venting methods as for a liquid seal trap, in accordance with Section P3101. Non-liquid seal devices shall not be installed on the outlet of a urinal. Where installed, the devices shall be installed only in the vertical downward orientation or in horizontal waste branches in accordance with Section P3005.3. The devices shall be installed in accordance with the manufacturer's instructions and shall be accessible.

Revise as follows:

P3201.1 Design of traps-Liquid Seal Traps. Traps relying on a liquid seal shall be of standard design, shall have smooth uniform internal waterways, shall be self-cleaning and shall not have interior partitions except where integral with the fixture. Traps shall be constructed of lead, cast iron, copper or copper alloy or *approved* plastic. Copper or copper-alloy traps shall be not less than No. 20 gage (0.8 mm) thickness. Solid connections, slip joints and couplings shall be permitted to be used on ~~the liquid seal type trap inlets, liquid seal type trap outlet~~ inlets, liquid seal type trap outlet, or within the liquid seal type trap seal. Slip joints shall be permitted on non-liquid seal devices conforming to Section P3201.3. Traps and other approved devices having slip-joint connections shall comply with Section P2704.1.

P3201.2 Trap seals-Liquid seal traps. Each fixture trap with a liquid seal shall have a liquid seal of not less than 2 inches (51 mm) and not more than 4 inches (102 mm).

Exception: Sealing devices not relying on a liquid seal shall conform to the requirements in Section P3201.3.

P3201.3P3201.4 Liquid Seal Trap setting and protection. ~~Traps-Liquid seal traps~~ shall be set level with respect to their water or other liquid seals and shall be protected from freezing. Trap seals shall be protected from siphonage, aspiration or back pressure by an *approved* system of venting (see Section P3101).

Exception: Sealing devices not relying on a liquid seal shall conform to the requirements in P3201.3.

P3201.4P3201.5 Building traps. Building traps shall be prohibited.

P3201.5P3201.6 Prohibited trap designs. The following types of traps are prohibited:

1. Bell traps.
2. Separate fixture traps with interior partitions, except those lavatory traps made of plastic, stainless steel or other corrosion-resistant material.
3. "S" -traps.
4. Drum traps.
5. Trap designs with moving parts.

Exception: Non-Liquid seal type devices conforming to ASME A112.18.8 and in accordance with Section P3201.3

P3201.6P3201.7 Number of fixtures per trap. Each plumbing fixture shall be separately trapped by a water seal ~~trap-trap~~ or a device conforming to the requirements in Section P3201.3. The vertical distance from the fixture outlet to the trap weir of a liquid seal trap or the inlet of a device meeting the requirements of Section P3201.3 shall not exceed 24 inches (610 mm) and the horizontal offset distance of a liquid seal trap shall not exceed 30 inches (762 mm) measured from the centerline of the fixture outlet to the centerline of the inlet of the trap. The height of a clothes washer standpipe above a trap shall conform to Section P2706.1.2. Fixtures shall not be double ~~trapped-trapped~~ with liquid seal traps and/or devices covered under section P3201.3.

Exceptions:

1. Fixtures that have integral traps.
2. A single trap or non-liquid seal device shall be permitted to serve two or three like fixtures limited to kitchen sinks, laundry tubs and lavatories. Such fixtures shall be adjacent to each other and located in the same room with a continuous waste arrangement. The trap shall be installed at the center fixture where three fixtures are installed. Common trapped fixture outlets shall be not more than 30 inches (762 mm) apart.
3. Connection of a laundry tray waste line into a standpipe for the automatic clothes-washer drain shall be permitted in accordance with Section P2706.1.2.1.

P3002.3.1 Drainage. Drainage fittings shall have a smooth interior waterway of the same diameter as the piping served. Fittings shall conform to the type of pipe used. Drainage fittings shall not have ledges, shoulders or reductions that can retard or obstruct drainage flow in the piping. Threaded drainage pipe fittings shall be of the recessed drainage type, black or galvanized. Drainage fittings shall be designed to maintain one-fourth unit vertical in 12 units horizontal (2-percent slope) grade. This section shall not be applicable to tubular waste fittings used to convey vertical flow upstream of the trap liquid seal liquid level of a fixture trap or a device conforming to P3201.3.

P3005.2.5 Cleanout size. Cleanouts shall be the same size as the piping served by the cleanout, except cleanouts for piping larger than 4 inches (102 mm) need not be larger than 4 inches (102 mm).

Exceptions:

1. A removable P-trap or non-liquid seal type device conforming to Section P3201.3 with slip- or ground-joint connections can serve as a cleanout for drain piping that is one size larger than the P-trap-tubular drain size.
2. Cleanouts located on stacks can be one size smaller than the stack size.
3. The size of cleanouts for cast-iron piping can be in accordance with the referenced standards for cast iron fittings as indicated in Table P3002.3.

P2704.1 Slip joints. Slip-joint connections shall be installed only for tubular waste piping and only between the trap outlet tailpiece of a fixture and traps, within traps, on devices conforming to section P3201.3, and on the connection to between tubular fixture drains and the drainage piping. piping system. Slip-joint connections shall be made with an approved elastomeric sealing gasket. Slip-joint connections shall be accessible. Such access shall provide an opening that is not less than 12 inches (305 mm) in its smallest dimension.

P2717.2 Sink and dishwasher. The combined discharge from a dishwasher and a one- or two-compartment sink, with or without a food-waste disposer, shall be served by a trap or device conforming to section P3201.3 of not less than 1½ inches (38 mm) in outside diameter. The dishwasher discharge pipe or tubing shall rise to the underside of the counter and be fastened or otherwise held in that position before connecting to the head of the food-waste disposer or to a wye fitting in the sink tailpiece.

Add new standard(s) follows:

ASME

American Society of Mechanical
Engineers
Two Park Avenue
New York NY 10016-5990

ASME A112.18.8-2009 (R2014) :

In-Line Sanitary Waste Valves for Plumbing Drainage Systems

Reason:

ASME standard A112.18.8-2009 (Re-affirmed in 2014) titled: "In-Line Sanitary Waste Valves for Plumbing Drainage" was developed for sanitary waste devices for use in lieu of p-traps for applications prone to liquid seal loss from evaporation, siphoning or freezing. They are certified by a third-party testing lab to the testing requirements in the ASME A112.18.8 Standard listed below. The devices are limited to tubular drains in sizes 1-1/4 inch or 1-1/2 inch outside diameter (OD).

This proposal is to add these non-liquid seal devices as an alternative to liquid seal traps for applications where evaporation, siphoning or freezing can be a problem. These devices will not fail from evaporation associated with long periods of non-use as would occur with a water filled p-trap or from negative pressures in the drainage systems that would siphon a p-trap, or from freezing which can crack or damage p-traps and p-trap joints. These devices

conform to ASME A112.18.8 and they are non-liquid sealing devices not traps or p-traps. They are an alternative to, and a better means of complying with the requirements of preventing sewer gases from entering a building. They fulfill the same function of a p-trap to not allowing sewer gases to pass into the building. These devices are approved and widely used in Europe and other international markets.

These devices are ideally suited for situations where plumbing fixtures experience only occasional use and can evaporate, like seasonal occupancy dwellings, vacation homes, guest bathrooms, cabins, on bar sinks, in low humidity conditions, or in persistent high temperature conditions. They also offer protection in freezing conditions and where there are limited or confined space conditions where a p-trap can conflict with structural or other building components. Other common uses for this type of device are in recreational vehicles and ships or boats

These devices have performed reliably for many years in millions of installations worldwide. They offer a better, more reliable option to a liquid seal p-trap especially in cases where evaporation, siphoning or freezing conditions exist.

The testing and performance requirements in the Standard for these devices are very stringent. P-Traps do not have a standard and are not tested. The tests for this device meet and exceed the performance capabilities of a p-trap. The tests in the standard include the following:

1. Seal materials shall meet various listed standards
2. Valve inlet/Outlet dimensions
3. Threaded connection dimensions
4. Gas-tight seal tests
5. Minimum flow rate tests for various tubing sizes/fixtures
6. One-way sealing performance tests
7. Airway flow rate tests
8. Thermal cycling Test
9. Long term cyclic fatigue tests
10. Grease/lard test
11. Resistance to cleaning chemicals and solvents test
12. Resistance to household substances and solids tests
13. Drop tests

The scope of the ASME A112.18.8 Standard establishes minimum requirements for materials in the construction of the devices for use as an alternate to tubular p-traps, and prescribes the minimum test requirements for the performance of the valve. In addition, the standard requires the methods of permanent marking and identification of the product. The standard also states that these devices are not intended to be used for urinals or water closets.

Below is an example of the type of valve that complies with the Standard:

Cost Impact

The code change proposal will not increase or decrease the cost of construction .

This code change is for a device that is an option to a p-trap. It is not required and therefore, will not cause an increase in construction. P-traps are still allowed. However, this code change allows for a better performing product as an approved option for areas where evaporation associated with seldom use of a fixture, siphoning or freezing may be an issue.

Analysis: A review of the standard proposed for inclusion in the code, ASME A112.18.8-2009(R2014), with regard to the ICC criteria for referenced standards (Section 3.6 of CP#28) will be posted on the ICC website on or before April 2, 2018.

Internal ID: 887

RP15-18

IRC: TABLE AG101.1

Proponent: Larry Gill, IPEX USA LLC, representing IPEX USA LLC (larry.gill@ipexna.com)

2018 International Residential Code

Revise as follows:

**TABLE AG101.1
PLASTIC PIPING STANDARDS FOR VARIOUS APPLICATIONS^{a, b}**

APPLICATION	LOCATION	TYPE OF PLASTIC PIPING									
		ABS	CPVC	PE	PE-AL-PE	PE-RT	PEX	PEX-AL-PEX	PP	PVC	
Central vacuum	System piping	—	—	—	—	—	—	—	—	—	ASTM F2358
Foundation drainage	System piping	ASTM F628	—	ASTM F805	—	—	—	—	—	—	ASTM D2685 ASTM D2729 ASTM D3034
Geothermal ground loop	System piping	—	ASTM D2846 ASTM F441 ASTM F442 ASTM F2855 CSA B137.6	ASTM D2239 ASTM D2737 ASTM D3035	ASTM F1282	ASTM F2623 ASTM F2769 CSA B137.3B	ASTM F876 CSA B137.5	ASTM F1281	ASTM F2389 CSA B137.11	ASTM D1785 ASTM D2241 CSA B137.3	
	Loop piping	—	—	ASTM D2239 ASTM D2737 ASTM D3035 NSF 306-1	ASTM F1282	ASTM F2623 ASTM F2769 CSA B137.3B	ASTM F876 CSA B137.5	—	ASTM F2389 CSA B137.11	—	
Geothermal water	Nonpressure distribution/collection	ASTM F628	—	ASTM D2239 ASTM D2737 ASTM D3035 ASTM F2306	—	—	—	—	ASTM F2389 CSA B137.11	ASTM D1785 ASTM D2729 ASTM D2949 ASTM D3035 ASTM F891 ASTM F1760 CSA B137.3	
	Pressure distribution	—	ASTM D2846 ASTM F441 ASTM F442 ASTM F2855 CSA B137.6	ASTM D2239 ASTM D2737 ASTM D3035	ASTM F1282	ASTM F2623 ASTM F2769 CSA B137.3B	ASTM F876 CSA B137.5	ASTM F1281	ASTM F2389 CSA B137.11	ASTM D1785 ASTM D2241 CSA B137.3	
Radiant cooling	Loop piping	—	ASTM D2846 ASTM F441 ASTM F442 ASTM F2855	ASTM D2239 ASTM D2737 ASTM D3035	ASTM F1282	ASTM F2623 ASTM F2769 CSA B137.3B	ASTM F876 CSA B137.5	ASTM F1281	ASTM F2389 CSA B137.11	—	
Radiant heating	Loop piping	—	ASTM D2846 ASTM F441 ASTM F442 ASTM F2855	—	ASTM F1282	ASTM F2623 ASTM F2769 CSA B137.3B	ASTM F876 CSA B137.5	ASTM F1281	ASTM F2389 CSA B137.11	—	
Rainwater harvesting	Nonpressure/collection	ASTM F628	—	ASTM F1901	—	—	—	—	ASTM F2389 CSA B137.11	ASTM D1785 ASTM D2729 ASTM D2949 ASTM F891 ASTM F1760 CSA B137.3	
	Pressure/distribution	—	ASTM D2846 ASTM F441 ASTM F442 ASTM F2855 CSA B137.6	ASTM D2239 ASTM D2737 ASTM D3035	ASTM F1282	ASTM F2623 ASTM F2769 CSA B137.3B	ASTM F876 CSA B137.5	ASTM F1281	ASTM F2389 CSA B137.11	ASTM D1785 ASTM D2241 CSA B137.3	
Radon venting	System piping	ASTM F628	—	—	—	—	—	—	—	—	ASTM D1785 ASTM F891 ASTM F1760
Reclaimed water	Main to building service	—	ASTM D2846 ASTM F441 ASTM F442 ASTM F2855 CSA B137.6	ASTM D3035 AWWA C901 CSA B137.1	ASTM F1282	ASTM F2623 ASTM F2769 CSA B137.3B	ASTM F876 AWWA C904 CSA B137.5	—	ASTM F2389 CSA B137.11	ASTM D1785 ASTM D2241 AWWA C905 CSA B137.3	
	Pressure/distribution/irrigation	—	ASTM D2846	ASTM D2239	ASTM F1282	ASTM F2623	ASTM F876	ASTM F1281	ASTM F2389 AWWA	ASTM D1785	

			ASTM F441 ASTM F442 ASTM F2855 CSA B137.5	ASTM D2737 ASTM D3035		ASTM F2769 CSA B137.5B	CSA B137.5		C900 CSA B137.11	ASTM D2241 AWWA C900
Residential fire sprinklers ^c	Sprinkle piping	—	ASTM F441 ASTM F442 CSA B137.5-UL 1821	—	—	ASTM F2769 CSA B137.5B	ASTM F876 CSA B137.5 UL 1821	—	ASTM F2389 CSA B137.11	—
Solar heating	Pressure/distribution	—	ASTM D2846 ASTM F441 ASTM F442 ASTM F2855	—	—	ASTM F2523 ASTM F2769 CSA B137.5B	ASTM F876 CSA B137.5	ASTM F1281	ASTM F2389 CSA B137.11	—

- a. This table indicates manufacturing standards for plastic piping materials that are suitable for use in the applications indicated. Such applications support green and sustainable building practices. The system designer or the installer of piping shall verify that the piping chosen for an application complies with local codes and the recommendations of the manufacturer of the piping.
- b. Fittings applicable for the piping shall be as recommended by the manufacturer of the piping.
- c. Piping systems for fire sprinkler applications shall be listed for the application.

Reason:

This change is to add CSA B137.18 to the various applications in Table AG 101.1. CSA B137.18 is already included in the I Codes and is referenced in Chapter 44 - Reference Standards of the 2018 IRC.

Bibliography:

CSA B137.18 Polyethylene of Raised Temperature (PE-RT) Tubing Systems for Pressure Applications

Cost Impact

The code change proposal will not increase or decrease the cost of construction .

This standard is only another option to choose from. More options generally result in a lowering of the costs of construction.

Internal ID: 1045

RP16-18

IRC: Appendix U (New)

Proponent: Ed Osann, representing Natural Resources Defense Council (eosann@nrdc.org)

2018 International Residential Code

Add new text as follows:

APPENDIX U **Water Efficiency**

AU101.1 Scope. This appendix shall apply to:

1. New buildings.
2. Additions to existing buildings.
3. Alterations to existing buildings.

SECTION AU102 DEFINITIONS

AU102.1 General. The following words and terms, for purposes of this appendix, shall have the meanings shown herein. Chapter 2 shall be referred to for general definitions.

Add new definition as follows:

AUTOMATIC. Self-acting, operating by its own mechanism when actuated by some impersonal influence, such as a change in current strength, pressure, temperature, or mechanical configuration.

AUTOMATIC IRRIGATION CONTROLLER. A timing device used to remotely control valves that operate an irrigation system.

REGENERATION. The maintenance process that restores a medium in a system so that it can continue to perform its water treatment function.

RUNOFF. Water that is not absorbed by the soil or landscape to which it is applied and flows from the landscape area.

SUBMETER. A meter installed subordinate to a utility service meter.

WATER SOFTENER. A pressurized water treatment device in which hard water is passed through a bed of cation exchange media (either inorganic or synthetic organic) for the purpose of exchanging calcium and magnesium ions for sodium or potassium ions, thus producing a softened water that is more desirable for laundering, bathing, and dishwashing.

AU103 PLUMBING FIXTURES AND FIXTURE FITTINGS

AU103.1 Maximum flow and water consumption. The maximum water consumption flow rates and quantities for plumbing fixtures and fittings shall be in accordance with Table AU103.1.

TABLE AU103.1

MAXIMUM FLOW RATES AND CONSUMPTION FOR PLUMBING FIXTURES AND FIXTURE FITTINGS^b

PLUMBING FIXTURE OR FITTING	MAXIMUM FLOW RATE OR QUANTITY
Lavatory faucet	1.5 gpm at 60 psi
Shower head ^a	2.0 gpm at 80 psi
Sink faucet ^c	1.8 gpm at 60 psi
Water closet	1.28 gallons per flushing cycle

For SI: 1 gallon per minute = 3.785 L/m, 1 pound per square inch = 6.895 kPa

a. A handheld shower spray shall be considered to be a shower head.

b. Consumption tolerances shall be determined from referenced standards.

c. Kitchen faucets shall be permitted to have a temporary increase in flow to not exceed 2.2 gpm provided that upon either the user's physical release of the increased flow activation mechanism or the user's closure of the faucet valve, the faucet reverts to the flow indicated in the table.

AU104 WATER SOFTENERS AND TREATMENT DEVICES

AU104.1 Water softeners. Water softeners shall be listed and labeled in accordance with NSF 44 and shall comply with Sections AU104.1.1 through AU104.1.3.

AU104.1.1 Demand-initiated regeneration. Water softeners shall be equipped with demand-initiated regeneration control systems. Such control systems shall automatically initiate the regeneration cycle after determining the depletion, or impending depletion, of softening capacity.

AU104.1.2 Water consumption. Water softeners shall have a maximum water consumption during regeneration of 4 gallons per 1,000 grains of hardness removed as measured in accordance with NSF 44.

AU104.1.3 Salt efficiency. Water softeners shall have a rated salt efficiency of not less than 4,000 grains of total hardness exchange per pound of salt, based on sodium chloride equivalency.

AU104.2 Reverse osmosis water treatment systems. Point-of-use reverse osmosis systems shall be equipped with an automatic shutoff valve that prevents the production of reject water when there is no demand for treated water.

AU105 AUTOMATIC IRRIGATION SYSTEMS

AU105.1 Automatic irrigation controllers. Where installed as part of a permanent landscape irrigation system, irrigation controllers shall regulate irrigation based on weather, climatological, or soil moisture status data. The controller shall have an integrated or separate sensor to suspend irrigation events during rainfall.

AU105.2 Misdirection and runoff prohibited. Automatic irrigation systems shall not direct water onto building exterior surfaces, foundations, exterior paved surfaces, or adjoining lots. Systems shall not generate runoff.

AU105.3 Landscape water measurement. A submeter shall be installed to separately record the volume of all water supplied to an outdoor landscape with an irrigated area of 5,000 square feet or greater served by an automatic irrigation system.

Exception: Where a utility service meter is installed to record the volume of all water supplied to the landscape through a service connection dedicated to irrigation.

Reason:

This proposal adds a short, voluntary appendix to the IRC containing requirements that will enhance the water efficiency of dwellings subject to the code. The language of this appendix is NOT mandatory unless, and to the extent, specifically referenced in the adopting ordinance or regulation of the jurisdiction.

The purpose of the proposal is to offer enhanced water efficiency provisions applicable to one- and two-family homes in code language for consideration by jurisdictions using the IRC. The ICC offers enhanced or "stretch code" provisions for large buildings in the International Green Construction Code (IgCC), but the IgCC does NOT apply to low-rise residential buildings. The ICC also offers "green" building standards for residential buildings of all sizes in ICC 700, the National Green Building Standard. However, ICC 700 is a points-based rating system, NOT code language, and the practices in its chapter on water efficiency are not mandatory. This new appendix will fill this gap, allowing jurisdictions that customarily use the IRC the opportunity to consider enhanced water efficiency requirements in familiar code format.

The proposal is intentionally brief, focusing on three areas of water consumption where enhanced performance criteria are well-known, and that together are responsible for the great majority of single-family residential water use in nearly all jurisdictions -- plumbing products, water softening, and landscape irrigation.

* Plumbing products: Requirements are based on performance levels established by the US EPA WaterSense Program for water closets, lavatory faucets, and showerheads, and by the 2016 California Green Building Standards Code (CalGreen) for kitchen faucets. These provisions are all found in IgCC 2015 as well, in Table 702.1, applicable to

residential occupancies covered by that code.

* Water softeners and treatment devices: These requirements for water use and salt efficiency (an important consideration for maintaining water quality and the ability to beneficially recycle municipal wastewater) were all included in section 704 of IgCC 2015, and are adopted here for applicability to the one- and two-family homes covered by the IRC. Water consumption during regeneration and salt efficiency are considered "elective performance claims" under NSF 44, and must be verified by test procedures laid out in section 711 of that standard. The requirements for demand-initiated regeneration and salt efficiency have been mandatory requirements for all residential water softeners installed in California since 2002.

* Automatic irrigation systems: These requirements are also drawn from the IgCC, where landscape metering requirements are specified in section 701.2.1 and other irrigation system requirements are laid out in section 404.1.2. Although the IgCC requires separate metering for irrigated landscapes of all sizes, a less stringent requirement may be appropriate for single-family residences. This proposal limits the metering requirement to residential landscapes of 5,000 square feet or more, the threshold of applicability for landscape metering contained in the California Code of Regulations, Title 23, Chapter 2.7, also known as the Model Water Efficient Landscape Ordinance (MWELO). MWELO also requires that irrigation controllers in all newly permitted landscape installations in California be either weather-based or soil moisture sensor-based, as required in this proposal. Note that the requirements of section AU105 are only applicable to permanent irrigation systems with automatic controls, and have no applicability to hose-end sprinklers.

Terms that are not otherwise defined in the IRC are included in a definitions section of the appendix. The definitions have been drawn variously from the IgCC, MWELO, the IAPMO Green Plumbing and Mechanical Code Supplement, and NSF 330.

It should be noted that when considering this voluntary appendix, adopting jurisdictions are free to adopt the appendix in its entirety, but may adopt any individual provision of their choosing that they find most relevant to local conditions and most practical for enforcement. Each element of the proposal stands on its own. The scope of the proposal has also been drafted in such a way as to highlight its applicability to project types (new buildings, additions to buildings, and alterations) and allow adopting jurisdictions full latitude to narrow the scope in that regard should they so choose.

Each successive year brings new evidence of the impacts of our changing climate, and significant among these impacts are greater extremes and frequency of both droughts and floods. The hydrological record of the last 100 years has become less useful as a predictor of water supply reliability. Few can doubt that efficient water use will become even more important in the decades ahead than it is today. Residential water use typically constitutes 60 to 65% of all publicly supplied drinking water, and the majority of residential use is found in single-family homes. For all these reasons, the IRC would be made more valuable to jurisdictions throughout the country if it included enhanced water efficiency criteria in clear code language for voluntary adoption.

Bibliography:

American Water Works Association/Raftelis Financial Consultants Inc., 2016 Water and Wastewater Rate Survey
ICC-ES Water Efficient Plumbing Fixtures -- <http://www.icc-es.org/News/Articles/High-efficiencyPlumbingFixtures.pdf>
Plumbing Manufacturers International, Water Efficiency Overview -- www.safeplumbing.org/water-efficiency
National Association of Homebuilders, ICC/ASHRAE 700-2015, National Green Building Standard
NSF International, NSF/ANSI 44-2016, Residential Cation Exchange Water Softeners
NSF International, NSF/ANSI 330-2015, Glossary of Drinking Water Treatment Unit Terminology
International Association of Plumbing and Mechanical Officials, 2015 Green Plumbing & Mechanical Code Supplement
California Department of Water Resources, Model Water Efficient Landscape Ordinance, California Code of Regulations, Title 23, Chapter 2.7, [www.water.ca.gov/wateruseefficiency/landscapeordinance/docs/Title_23 extract - Official CCR pages.pdf](http://www.water.ca.gov/wateruseefficiency/landscapeordinance/docs/Title_23_extract_-_Official_CCR_pages.pdf)
California Energy Commission, "Staff Analysis of Water Efficiency Standards for Showerheads," Docket Number 15-AAER-05, p. 13, August 7, 2015, http://docketpublic.energy.ca.gov/PublicDocuments/15-AAER-05/TN205654_20150807T151426_Staff_Analysis_Of_Water_Efficiency_Standards_For_Showerheads.pdf
California Energy Commission, "Staff Analysis of Lavatory Faucet Appliance Standards," Docket Number 15-AAER-05, July 24, 2015, http://docketpublic.energy.ca.gov/PublicDocuments/15-AAER-05/TN205513_20150724T152718_Staff_Analysis_of_Lavatory_Faucet_Appliance_Standards.pdf
California Legislative Information, California Health and Safety Code, §§ 116775-116795
US Environmental Protection Agency, WaterSense Program, www.epa.gov/watersense/technical-specifications

Cost Impact

The code change proposal will not increase or decrease the cost of construction .

The proposal offers enhanced water efficiency specifications for voluntary adoption by jurisdictions using the IRC. As such, there is no general impact on users of the IRC.

The content of this voluntary appendix establishes enhanced efficiency criteria for plumbing products, water softeners, and certain landscape irrigation equipment.

Regarding plumbing products, products are widely available from multiple manufacturers. Based on US EPA WaterSense product listings, as of September 2017 there are over 3,100 models of tank-type toilets, over 15,000 models of lavatory faucets, and nearly 6,000 models of showerheads that meet the criteria in this proposal. Although prices for plumbing products vary widely, based on considerations of style, color, and trim, there is no price premium attached to higher water use efficiency per se. See, for example, the staff reports of the California Energy Commission on standards for lavatory faucets and showerheads that found no price premium for products performing at the level proposed in this voluntary appendix.

Regarding water softeners, costs vary widely, but much of this difference is due to capacity, rather than efficiency of performance. The key criteria in this proposal have been statewide requirements for residential water softeners in California since 2002. As such, compliant products are widely available from multiple manufacturers. By way of illustration, as of this writing, the least expensive residential cation exchange water softener now available from Lowes fully complies with all criteria in this proposal (http://pdf.lowes.com/installationguides/090259891214_install.pdf), as does the least expensive cation exchange water softener available from Home Depot (<https://www.homedepot.com/b/Kitchen-Water-Filters-Water-Softeners/N-5yc1vZaq3y/Ntk-semanticsearch/Ntt-water+softener?NCNI-5>).

Regarding irrigation controllers, prices also vary widely, with a major driver being the number of zones controlled by the controller. Some 800 models of irrigation controllers have been certified to the WaterSense specification for weather-based irrigation controllers, so supply and choice of compliant products are ample. Smart controllers are now required for all newly permitted landscape installations in California, ensuring continued competitive interest in this product area. The prevailing price differential between a timer-based controller and a smart controller meeting the criteria of this proposal has been around \$100. But several products are on the market that cut this differential in half, and at least one weather-based irrigation controller is now on the market at a price comparable to a timer-based controller.

When products meet enhanced criteria for water efficiency, costs are typically recouped by savings on water and/or sewer charges over the life of the product. According to the 2016 Water and Wastewater Rate Survey, over the last decade, water charges have annually increased by 5.34 % and wastewater charges have annually increased by 5.98 %, far exceeding the annual inflation rate of 2.07 % for that period. These trends are expected to continue, underscoring the cost-effectiveness of installation of water-efficient products.

Internal ID: 2264

2018 GROUP A – PROPOSED CHANGES TO THE INTERNATIONAL SWIMMING POOL AND SPA CODE

SWIMMING POOL AND SPA CODE COMMITTEE

Edward Kulik, Chair

Chief Building Official
Building Division
Mohave County Development Services
Kingman, AZ

Donald Leas, Vice Chair

Rep: Association of Pool & Spa Professionals
Consultant
United States Of America Diving
Mayport, PA

Steve Barnes, CPO

Rep: Association of Pool & Spa Professionals
Director of Science and Compliance
AquaStar Pool Products, Inc.
Ventura, CA

Theresa Bellish

General Manager of Municipal and Recreational
Water Product Certification
NSF International
Ann Arbor, MI

Larry W. Brock

Building Inspector III
Chesterfield County
Chesterfield, VA

Joseph R. Crum, CBO

Rep: Orange County, FL
Commercial Plans Examiner
Orange County Building Safety
Orlando, FL

Dale Engebretson, MCP

Chief Code Official
City of Warrenville
Warrenville, IL

Kenneth Gregory

Compliance and Safety Manager
Pentair Water Quality Systems
Washington, UT

Lee Hovis

Director of Operations and Recreation
Tolomato Community Development District
Ponte Vedra, FL

Eugene “Gene” Novak, Jr., CBO

Rep: Metro West Building Officials of MA
District State Building Inspector
Commonwealth of Massachusetts
Dept. of Public Safety
Framingham, MA

Michael Olson

City of McGregor
Kempner, TX

Michael Ribnikar

Rep: Association Pool and Spa Professionals
VP Operations, Premier Pools & Spas
Premier Pools & Spas/Dallas Office
Plano, TX

Shajee Siddiqui

Rep: Association of Pool & Spa Professionals
Director, Global Product Safety & Compliance
Zodiac Pool Systems, Inc.
Vista, CA

Shawn Still

Rep: Association of Pool and Spa Professionals
(APSP)
President & CEO
Olympic Pool Plastering
Norcross, GA

Staff Secretariat:

Fred Grable, PE

Senior Staff Engineer - Plumbing
International Code Council
Central Regional Office
Country Club Hills, IL

TENTATIVE ORDER OF DISCUSSION 2018 PROPOSED CHANGES TO THE INTERNATIONAL SWIMMING POOL AND SPA CODE

The following is the tentative order in which the proposed changes to the code will be discussed at the public hearings. Proposed changes which impact the same subject have been grouped to permit consideration in consecutive changes.

Proposed change numbers that are indented are those which are being heard out of numerical order. Indentation does not necessarily indicate that one change is related to another. Proposed changes may be grouped for purposes of discussion at the hearing at the discretion of the chair. Note that some SP code change proposals may not be included on this list, as they are being heard by another committee.

P1-18 Part V	SP38-18
SP1-18	SP39-18
SP2-18	SP40-18
SP3-18	SP41-18
SP4-18	SP42-18
SP5-18	SP43-18
SP6-18	SP44-18
SP7-18	SP45-18
SP8-18	SP46-18
SP9-18	SP47-18
SP10-18	SP48-18
SP11-18	SP49-18
SP12-18	
SP13-18	
SP14-18	
SP15-18	
SP16-18	
SP17-18	
SP18-18	
SP19-18	
SP20-18	
SP21-18	
SP22-18	
SP23-18	
SP24-18	
SP25-18	
SP26-18	
SP27-18	
SP28-18	
SP29-18	
SP30-18	
SP31-18	
SP32-18	
SP33-18	
SP34-18	
SP35-18	
SP36-18	
SP37-18	

SP1-18

ISPSC: 202

Proponent: Jennifer Hatfield, J. Hatfield & Associates, PL, representing Association of Pool & Spa Professionals (jhatfield@apsp.org)

2018 International Swimming Pool and Spa Code

Revise as follows:

SWIMOUT. An underwater seat area that is placed completely outside of the ~~perimeter shape~~ diving envelope of the pool. Where located at the deep end, swimouts are permitted to be used as the deep-end means of entry or exit to the pool.

Reason:

A swimout is not required to be outside of the perimeter shape of a pool. Many times they are located on those areas but they are not required to be. This revised wording agrees with Figure 322.2.

Cost Impact

The code change proposal will not increase or decrease the cost of construction .

This proposal only clarifies the original intent and normal practice of where swimouts are installed.

Internal ID: 1785

SP2-18

ISPSC: 202

Proponent: John Kelly, Iowa Department of Public Health, representing self

2018 International Swimming Pool and Spa Code

Revise as follows:

SWIMOUT. An underwater ~~seat area shelf~~ shelf located in deep water that is placed completely outside of the perimeter shape of the pool. ~~Where located at the deep end, swimouts are permitted to be used as the deep end means of entry or exit to the pool with stairs leading to the deck.~~

Reason:

The definition was changed to clarify the differences between swimouts and underwater seats. The definition of the swimout was changed to better align with its intent as a entry to and exit from the deep end of a pool. The code does not recognize a swimout in shallow water as one of the required entry/exit from the pool, so in shallow water it is simply an underwater bench/seat and should be constructed accordingly.

Cost Impact

The code change proposal will not increase or decrease the cost of construction .

This clarifies the definition of a swimout but the requirements for a swimout are addressed in another section of the code so this change in definition does not increase or decrease the cost of construction.

Internal ID: 1600

SP3-18

ISPSC: 202

Proponent: John Kelly, Iowa Department of Public Health, representing self

2018 International Swimming Pool and Spa Code

Revise as follows:

UNDERWATER SEAT-BENCH. ~~An underwater ledge that is seat that can be recessed into the pool wall or placed completely inside the perimeter shape of the pool, generally located in the shallow end of the pool.~~

Reason:

The current code refers to both underwater seats and benches but only an "underwater seat" is defined. It is more common to call a seat within a pool or spa simply as an "underwater bench", which would be consistent with the Model Aquatic Health Code. The definition should be changed from "underwater seat" to "underwater bench". Underwater benches are commonly recessed into the pool wall or placed completed inside the perimeter shape of the pool.

Cost Impact

The code change proposal will not increase or decrease the cost of construction .

This is simply clarifying the definition of an underwater bench (seat) . Any requirements for the underwater bench are addressed separately within the code.

Internal ID: 1652

SP4-18

ISPSC: 305.1

Proponent: Tommy Moberg, Town of Acton, representing Town of Acton

2018 International Swimming Pool and Spa Code

Revise as follows:

305.1 General. The provisions of this section shall apply to the design of barriers for restricting entry into areas having pools and spas. Where spas a spa or hot tubs are tub is equipped with a lockable safety cover complying with ASTM F1346 and swimming pools are the areas where the spa or hot tub are located shall not be required to comply with Sections 305.2 through 305.7.Where a swimming pool is equipped with a powered safety cover that complies with ASTM F1346, and such cover is equipped with an occupant sensor to close the cover automatically when the swimming pool is not in use after 20 minutes, or is equipped with smart controller that alerts the pool owner when the pool cover has been opened, closed, and the amount of time the cover is open, the areas where those spas, hot tubs or pools are located shall not be required to comply with Sections 305.2 through 305.7.

Reason:

In the years leading up to the 2015 IPSC there has been a requirement for a passive barrier system. A design of that system was such that forgetting to close a gate, or close a door to the pool area was taken out of the day to day practice of pool safety. Install your barrier fence, self closing gates, alarms if needed and use your pool. But the new language only consists of an active system, and relies on the owner to uncover and recover the hazard after every use. This system has a high potential of failure. There needs to be some additional safety measures that will assist the owner to insure that the pool is safe when they forget to close the power safety.

Cost Impact

The code change proposal will increase the cost of construction .

The cost of the WIFI controller is around \$340.00 US.

Internal ID: 1139

SP5-18

ISPSC: 305.1.1 (New)

Proponent: Pennie Feehan, representing Plumbing, Mechanical, and Fuel Gas Code Action Committee (PMGCAC@iccsafe.org)

2018 International Swimming Pool and Spa Code

Add new text as follows:

305.1.1 Construction fencing required. The construction sites for in-ground swimming pools and spas shall be provided with construction fencing to surround the site from the time that any excavation occurs up to the time that the permanent barrier is completed. The fencing shall be not less than 4 feet in height.

Reason:

Usually, a pool contractor is not responsible for the fencing whether permanent or temporary during construction of a pool. A pool can be under construction for several weeks (or more) which presents a fall hazard/drowning hazard where there is not some type of barrier in place. Sometimes a pool is completed and the builder has moved onto the next job without any barrier around the completed pool. This new section requires a temporary barrier until the permanent barrier is erected. The specifics about what type of barrier is acceptable are left up to the contractor with oversight by the code official. It is not the intent of this proposal to require a temporary barrier to be constructed to the same way as the code's requirements for a permanent barrier.

This proposal is submitted by the ICC Plumbing/Mechanical/Gas Code Action Committee (PMG CAC). The PMG CAC was established by the ICC Board of Directors to pursue opportunities to improve and enhance the International Codes or portions thereof that were under the purview of the PMG CAC. In 2017 the PMG CAC held one face-to-face meeting and 11 conference call meetings. Numerous interested parties attended the committee meetings and offered their input.

Cost Impact

The code change proposal will increase the cost of construction .

Rental of temporary construction fencing and its installation will add cost to a pool project for those contractors who have not already been taking precautions to secure the excavation/pool construction site. One national average for rental installation for 120' x 6 foot high of chain link fencing panels and bases for 1 month is \$480. Job site conditions and project site location could greatly affect the cost.

Internal ID: 523

SP6-18

ISPSC: 305.2.9

Proponent: Pennie Feehan, representing Plumbing, Mechanical, and Fuel Gas Code Action Committee (PMGCAC@iccsafe.org)

2018 International Swimming Pool and Spa Code

Revise as follows:

305.2.9 Clear zone. ~~There shall be a clear zone of~~ Where equipment, including pool equipment such as pumps, filters and heaters, is on the same lot as a pool or spa and such equipment is located outside of the barrier protecting the pool or spa, such equipment shall be located not less than 36 inches (914 mm) ~~between from the exterior of the barrier and any permanent structures or equipment such as pumps, filters and heaters that can be used to climb outside of~~ the barrier.

Reason:

When the ISPSC was drafted, the origin of the current language was the APSP standard covering on-ground pools. From the perspective of a 48 inch (or taller) wall of an on-ground pool serving as the barrier to entry into the pool and the fact that pumps, filters and heaters for on-ground pools are always on the outside of the pool wall, the current language has clear intent: don't locate such equipment (that can be climbed on top of) any closer than 36 inches from the outside of the pool wall.

However, as this section is located in the General Regulations chapter, the clear zone requirement applies to all pool types, including in-ground pools and spas that are required to have a separate barrier such as a fence. Although the requirement for not locating pool equipment in close proximity (less than 36 inches) to outside of the barrier (fence) is no less important, the possible locations of the barrier (fence) on the lot where the pool or spa is located creates enforcement difficulties. For example, where the barrier (fence) is located on one or more lot lines, the pool or spa owner has no legal control (over his neighbor) as to what the neighbor might place (within 36 inches) of the outside of the barrier (fence) nor can the code official enforce this code section on the neighbor (who is not the permit holder.) This has resulted in some building departments requiring that any pool (or spa) barriers (fences) be set back from any lot line by 36 inches so that pool owner (the lot owner) has the legal control over the 36 inch strip between the lot line and the pool barrier (fence.) The unfortunate results of this are: 1) for small lots, pools (or spas) cannot be as large or might not be feasible to build, 2) adjacent neighbors having pools will each have a barrier (fence) resulting in an unusable 6 feet wide strip of land between the fences, or 3) the presence of existing "permanent structures" on adjacent (neighboring) lots may preclude the installation of a pool or spa.

The original intent of the section was never intended to address any situation that was outside the confines of the lot on which the pool or spa is installed or constructed. Therefore, the revised language specifically addresses the required clearance with respect to pool equipment on the lot and not anything that is on the neighbor's side of the lot lines.

This proposal is submitted by the ICC Plumbing/Mechanical/Gas Code Action Committee (PMG CAC). The PMG CAC was established by the ICC Board of Directors to pursue opportunities to improve and enhance the International Codes or portions thereof that were under the purview of the PMG CAC. In 2017 the PMG CAC held one face-to-face meeting and 11 conference call meetings. Numerous interested parties attended the committee meetings and offered their input.

Cost Impact

The code change proposal will not increase or decrease the cost of construction .

This proposal will not increase the cost of construction because no additional labor, materials, equipment, appliances or devices are mandated beyond what is currently required by the code.

Internal ID: 524

SP7-18

ISPSC: 305.2.4.1 (New), 305.2.10

Proponent: Jennifer Hatfield, J. Hatfield & Associates, PL, representing Association of Pool & Spa Professionals (jhatfield@apsp.org)

2018 International Swimming Pool and Spa Code

Add new text as follows:

305.2.4.1 Setback for mesh fences. The inside of a mesh fence shall be not closer than 20 inches (508mm) to the nearest edge of the water of a pool or spa.

Delete without substitution:

~~**305.2.10 Poolside barrier setbacks.** The pool or spa side of the required barrier shall be not less than 20 inches (508 mm) from the water's edge.~~

Reason:

This proposal clarifies the original intent of section 305.2.10, which was to apply only to mesh fences, which are removable child barriers otherwise known as "baby barriers." The setback requirement was never intended to apply to walls, screen enclosures, other types of fencing, etc. The way the code is currently written it could be construed as applying to all types of barriers and not just the mesh fencing as intended. Therefore, this proposal simply deletes section 305.2.10 and then places this setback requirement as a subsection of the mesh fencing section, so it is applicable to only that type of barrier fence, as was always the original intent of this language.

Bibliography:

See 6th edition (2017) Florida Building Code, Section R4501.17.1.13 and any previous editions, which provide this language for mesh barriers:

R4501.17.1.13

Removable child barriers must be placed sufficiently away from the water's edge to prevent a young child or medically frail elderly person who may manage to penetrate the barrier from immediately falling into the water. Sufficiently away from the water's edge shall mean no less than 20 inches (508 mm) from the barrier to the water's edge. Dwelling or nondwelling walls including screen enclosures, when used as part or all of the "barrier" and meeting the other barrier requirements, may be as close to the water's edge as permitted by this code.

See 2007 Florida Building Code, Commentary for what was then section R4101.17.1.13, which provides commentary that clearly notes the intent of the setback is only for mesh fencing.

Cost Impact

The code change proposal will not increase or decrease the cost of construction .

This will not increase the cost of construction, as it simply clarifies the original intent of the code provision.

Internal ID: 1754

SP8-18

ISPS: 305.3, 305.3.1, 305.3.2, 305.3.3, 305.3.4 (New), 305.4

Proponent: Dawn Anderson, representing self (gonedawning@yahoo.com); Dan Buuck, representing National Association of Home Builders (dbuuck@nahb.org); David Collins, representing the American Institute of Architects (dcollins@preview-group.com); Marsha Mazz, representing U.S. Access Board (mazz@Access-Board.gov); Dominic Marinelli, representing United Spinal Association (DMarinelli@accessibility-services.com)

2018 International Swimming Pool and Spa Code

Revise as follows:

305.3 Gates—Doors and gates. ~~Access—Doors and gates in barriers shall comply with the requirements of Sections 305.3.1 through 305.3.3 and shall be equipped to accommodate a locking device. Pedestrian access doors and gates shall open outward away from the pool or spa, shall be self-closing and shall have a self-latching device.~~

305.3.1 Utility or service doors and gates. ~~Gates—Doors and gates not intended for pedestrian use, such as utility or service doors and gates, shall remain locked when not in use.~~

305.3.2 Double or multiple doors and gates. ~~Double doors and gates or multiple doors and gates shall have not fewer than one leaf secured in place and the adjacent leaf shall be secured with a selflatching device. The gate and barrier shall not have openings larger than $\frac{3}{4}$ inch (12.7 mm) within 18 inches (457 mm) of the latch release mechanism. The self-latching device shall comply with the requirements of Section 305.3.3.~~device.

Delete and substitute as follows:

305.3.3 Latches. ~~Where the release mechanism of the self-latching device is located less than 54 inches (1372 mm) from grade, the release mechanism shall be located on the pool or spa side of the gate not less than 3 inches (76 mm) below the top of the gate, and the gate and barrier shall not have openings greater than $\frac{3}{4}$ inch (12.7 mm) within 18 inches (457 mm) of the release mechanism.~~

305.3.3 Latch release. For doors and gates in barrier, the door and gate latch release mechanisms shall be in accordance with the following:

1. Where door and gate latch release mechanisms are accessed from the outside of the barrier and are not of the self-locking type, such mechanism shall be located above the finished floor or ground surface in accordance with the following:
 - 1.1. At public pools and spas, not less than 52 inches (1219 mm) and not greater than 54 inches (1372 mm).
 - 1.2. At residential pools and spas, not less 54 inches (1372 mm)
2. Where door and gate latch release mechanisms are of the self-locking type such as where the lock is operated by means of a key, an electronic opener or the entry of a combination into an integral combination lock, the lock operation control and the latch release mechanism shall be located above the finished floor or ground surface in accordance with the following:
 - 2.1. At public pools and spas, not less than 34 inches and not greater than 48 inches (1219 mm).
 - 2.2. At residential pools and spas, at not greater than 54 inches (1372 mm).
3. At private pools, where the only latch release mechanism of a self-latching device for a gate is located on the pool and spa side of the barrier, the release mechanism shall be located at a point that is at least 3 inches (76 mm) below the top of the gate.

Add new text as follows:

305.3.4 Barriers adjacent to latch release mechanisms. Where a latch release mechanism is located on the inside of a barrier, openings in the door, gate and barrier within 18 inches (457 mm) of the latch, shall not be greater than $\frac{1}{2}$ inch (12.7 mm) in any dimension.

Revise as follows:

305.4 Structure wall as a barrier. Where a wall of a dwelling or structure serves as part of the barrier and where doors, gates or windows provide direct access to the pool or spa through that wall, one of the following shall be required:

1. Operable windows having a sill height of less than 48 inches (1219 mm) above the indoor finished floor, ~~doors and doors-gates~~ shall have an alarm that produces an audible warning when the window, door or their screens are opened. The alarm shall be *listed* and *labeled* as a water hazard entrance alarm in accordance with UL 2017.
2. In dwellings ~~or structures~~ not required to be Accessible units, Type A units or Type B units, the operable parts of the alarm deactivation switches shall be located at not less than 54 inches (1372 mm) or more above the finished floor.
3. In dwellings ~~or structures~~ that are required to be Accessible units, Type A units or Type B units, the operable parts of the alarm deactivation switches shall be located not greater than 54 inches (1372 mm) and not less than 48 inches (1219 mm) above the finished floor.
4. In structures other than dwellings, the operable parts of the alarm deactivation switches shall be located not greater than 54 inches (1372 mm) and not less than 48 inches (1220 mm) above the finished floor.
- ~~2-5.~~ A *safety cover* that is *listed* and *labeled* in accordance with ASTM F1346 is installed for the pools and spas.
- ~~3-6.~~ An *approved* means of protection, such as self-closing doors with self-latching devices, is provided. Such means of protection shall provide a degree of protection that is not less than the protection afforded by Item 1 or 2.

Reason:

Section 305.3.3 deals with latches for all gates providing access to a pool. Section 305.4 deals with alarms for doors and windows in a barrier. The current text seems to be applicable more for residential pools than public pools.

There are several reason for this proposal. Pools can be interior or exterior, so latch provisions should apply to doors as well as gates. The last sentence of 305.3.2 is not needed since Section 305.3 requires compliance with the whole section. Section 305.3.3 is dealing with a situation where you reach over a gate to open the latch. Fences around public pools are typically much higher. The requirements for latches should follow the IBC Section 1010.1.9.2. This section includes an exception for operable parts of manual latches to be above 48" so that they latch is outside the reach of children.

Section 305.4 Item 1 deals with the deactivation switch for alarms on doors or windows in a pool barrier. The same allowance for height protection for children is permitted. Dwelling units are separated from structures because this wall could be on a common corridor or in another building for pools that serve hotels, apartment buildings or other community buildings. In public areas these alarm shut offs must be accessible or addressed as employee only elements under Section 1103.2.2.

2018 IBC

1010.1.9.2 Hardware height. Door handles, pulls, latches, locks and other operating devices shall be installed 34 inches (864 mm) minimum and 48 inches (1219 mm) maximum above the finished floor. Locks used only for security purposes and not used for normal operation are permitted at any height.

Exception: Access doors or gates in barrier walls and fences protecting pools, spas and hot tubs shall be permitted to have operable parts of the release of latch on self-latching devices at 54 inches (1370 mm) maximum above the finished floor or ground, provided the self-latching devices are not also self-locking devices operated by means of a key, electronic opener or integral combination lock.

Cost Impact

The code change proposal will not increase or decrease the cost of construction .

This is a clarification of the height for pool latches and alarms only. There is no change to the cost for construction.

Internal ID: 551

SP9-18

ISPSC: 305.3.3, 305.4

Proponent: Jennifer Hatfield, J. Hatfield & Associates, PL, representing Association of Pool & Spa Professionals (jhatfield@apsp.org)

2018 International Swimming Pool and Spa Code

Revise as follows:

305.3.3 Latches. ~~Where Operable parts of the latch release mechanism of for the self-latching device is located that are located on the side of the gate away from the pool or spa shall be located not less than 54 inches (1372 mm) from grade, the release mechanism shall be above the finished floor or ground, whichever is higher. For public pools and public spas, such latch release shall be located at 54 inches (1372 mm) above the finished floor or ground, whichever is higher. For residential pools and residential spas, where the latch release of the self-latching device is located on the pool or spa side of the gate and is less than 54 inches (1372 mm) above the finished floor or ground, the latch release shall be located not less than 3 inches (76 mm) below the top of the gate, and the gate and barrier shall not have openings greater than 1/2 inch (12.7 mm) within 18 inches (457 mm) of the release mechanism.~~ latch release.

305.4 Structure wall as a barrier. Where a wall of a dwelling or structure serves as part of the barrier and where doors or windows provide direct access to the pool or spa through that wall, one of the following shall be required:

1. Operable windows having a sill height of less than 48 inches (1219 mm) above the indoor finished floor and doors shall have an alarm that produces an audible warning when the window, door or their screens are opened. The alarm shall be *listed* and *labeled* as a water hazard entrance alarm in accordance with UL 2017. ~~In dwellings or structures dwelling units not required to be Accessible units, Type A units or Type B units, the operable parts of the alarm deactivation switches shall be located 54 inches (1372 mm) or more above the finished floor. In dwellings or structures dwelling units required to be Accessible units, Type A units or Type B units, or in structures where the swimming pool is required to be accessible, the operable parts of the alarm deactivation switches shall be located not greater than 54 inches (1372 mm) and not less than 48 inches (1219 mm) above the finished floor.~~
2. A *safety cover* that is *listed* and *labeled* in accordance with ASTM F1346 is installed for the pools and spas.
3. An *approved* means of protection, such as self-closing doors with self-latching devices, is provided. Such means of protection shall provide a degree of protection that is not less than the protection afforded by Item 1 or 2.

Reason:

The intent of the changes is to coordinate locking arrangements on gates and doors to public pools with the allowances worked out in the IBC as part of the coordination with ADA. At the same time, the language is being proposed to ensure that the latch is not under 54 inches, as this should not be permitted for safety reasons (all existing barrier codes and standards require a minimum 54 inches from the ground or floor to ensure a child cannot access the pool or spa without adult supervision). The definition for public pool and residential pool would determine where accessibility is appropriate.

Cost Impact

The code change proposal will not increase or decrease the cost of construction .

This proposal will not increase the cost of construction because no additional labor, materials, equipment, or devices are mandated beyond what is currently required by the code.

Internal ID: 1782

SP10-18

ISPSC: 305.8 (New)

Proponent: Timothy Pate, representing Colorado Chapter Code Change Committee (tpate@broomfield.org)

2018 International Swimming Pool and Spa Code

Add new text as follows:

305.8 Means of Egress. Outdoor public pools provided with barriers shall have means of egress as required by Chapter 10 of the International Building Code.

Reason:

I am proposing to add this new section that will give direction for outdoor public pools provided with barriers to have means of egress as required by Chapter 10 of the IBC. This will give direction as to how to figure out occupant loads along with required size and location of exits from pool and pool area. It will give direction for when you need doors or gates to swing in direction of travel and have panic hardware (when occupant load is 50 or more).

This is important in order to provide a safe exit system in the event of a weather event of possible chemical leak from pool chemical storage areas that may be adjacent to the pool areas.

I attempted to put language into section 305.3 during the 2015 code change cycle to calculate occupant load using the IBC and you would need to meet exit requirements from IBC for swing and panic hardware. The Committee had concerns that this would apply to both public and private pools and could also limit exits to only gates and not doors.

I brought it back to final action hearings by adding a new section in 305 and adding language to only apply to public pools.. I was not successful getting the required 2/3 vote to overturn the Committee recommendation for disapproval.

I would also clarify that this proposal is not adding any requirements to use the occupant load to determine required number of plumbing fixtures - only for means of egress requirements. Sections 403 and 410 have requirements for determining bather loads for Class B and C pools.

Cost Impact

The code change proposal will not increase or decrease the cost of construction .

This proposal is just to clarify existing code requirements

Internal ID: 1181

SP11-18

ISPSC: 307.1.2.1 (New), Chapter 11

Proponent: Jennifer Hatfield, J. Hatfield & Associates, PL, representing Association of Pool & Spa Professionals (jhatfield@apsp.org)

2018 International Swimming Pool and Spa Code

Add new text as follows:

307.1.2 Colors and finishes. For other than *residential* pools and *residential* spas, the colors, patterns, or finishes of the pool and spa interiors shall not obscure objects or surfaces within the pool or spa.

307.1.2.1 Interior finishes. The interior finish coating on floors and walls shall be comprised of a non-pigmented white or pastel cementitious binder component together with a sand/aggregate component. The finish coating shall have an overall dry lightness level (CIE L* value) of 80.0 or greater and an overall wet luminous reflectance value (CIE Y value) of 50.0 or greater, as determined by test results provided by the manufacturer, utilizing testing methodology from ASTM D4086, ASTM E1477 and ASTM E1347.

Add new standard(s) follows:

ASTM

ASTM International
100 Barr Harbor, P.O. Box C700
West Conshohocken PA 19428-
2959

D4086 - 92a(2012):

Standard Practice for Visual Evaluation of Metamerism

E1477 - 98a(2017):

Standard Test Method for Luminous Reflectance Factor of Acoustical Materials by Use of Integrating-Sphere Reflectometers

E1347 - 06(2015):

Standard Test Method for Color and Color-Difference Measurement by Tristimulus Colorimetry

Reason:

This proposal creates a quantifiable standard for allowable public pool and spa surface colors. The dry Lightness (CIE L* value) represents the whiteness of the dry finish surface when compared on a grey scale, where 0 = black and 100 = white. The wet Luminous Reflectance Value (CIE Y value) represents the brightness and/or contrast of the wet finish surface as a perceived visual response of the human eye. While neither value is a true representation, knowing both values allows additional insight into the finishes true aesthetic characteristics when placed in a water-submersion environment.

Bibliography:

Section 454.1.2.4 of the 6th edition (2017) Florida Building Code

Cost Impact

The code change proposal will not increase or decrease the cost of construction .

A finish is always required; this just puts parameters on what finishes are allowed; therefore, it does not increase the cost.

Analysis: A review of the standard proposed for inclusion in the code, ASTM D4086 - 92a(2012), ASTM E1477 - 98a(2017), and ASTM E1347 - 06(2015) with regard to the ICC criteria for referenced standards (Section 3.6 of CP#28) will be posted on the ICC website on or before April 2, 2018.

Internal ID: 2360

SP12-18

ISPSC: 307.1.2.1 (New)

Proponent: Jennifer Hatfield, J. Hatfield & Associates, PL, representing Association of Pool & Spa Professionals (jhatfield@apsp.org)

2018 International Swimming Pool and Spa Code

307.1.2 Colors and finishes. For other than *residential* pools and *residential* spas, the colors, patterns, or finishes of the pool and spa interiors shall not obscure objects or surfaces within the pool or spa.

Add new text as follows:

307.1.2.1 Munsell Color Value. Finishes shall be not less than 6.5 on the Munsell color value scale.

Exceptions: The following shall not be required to comply with this section:

1. Competitive lane markings.
2. Floors of dedicated competitive diving wells.
3. Step or bench edge markings.
4. Pools shallower than 24 inches (609.6 mm).
5. Water line tiles.
6. Wave and surf pool depth change indicator tiles.
7. Depth change indicator tiles where a rope and float line is provided.
8. Features such as rock formations, as approved.

Reason:

The Munsell color system looks at color purity, hue, and lightness to assign a value. This change will provide additional guidance on finish requirements for public pools and spas that will ensure consistency with the same requirements found in the Model Aquatic Health Code and in various state public pool codes regulated by health departments. This system is also used in other industries.

Bibliography:

Sections 4.5.11.1.1 - 4.5.11.1.3 of the Model Aquatic Health Code

<https://www.cdc.gov/mahc/editions/current.html>

Cost Impact

The code change proposal will not increase or decrease the cost of construction .

A finish is always required; this just puts parameters on what finishes are allowed; therefore, it does not increase the cost.

Internal ID: 1519

SP13-18

ISPSC: 307.1.4, Chapter 11

Proponent: Pennie Feehan, representing Plumbing, Mechanical, and Fuel Gas Code Action Committee (PMGCAC@iccsafe.org)

2018 International Swimming Pool and Spa Code

Revise as follows:

307.1.4 Accessibility. An accessible route to public pools and spas shall be provided in accordance with the International Building Code. Accessibility within public pools and spas shall be provided as required by the accessible recreational facilities provisions of the International Building Code. Pool and spa lifts providing an accessible means of entry into the water shall be listed and labeled in accordance with UL 60335-2-1000 and be installed in accordance with ICC A117.1 and NFPA 70.

Add new standard(s) follows:

UL

UL LLC
333 Pfingsten Road
Northbrook IL 60062

60335-2-1000:

Standard for Household and Similar Electrical Appliances: Particular Requirements for Electrically Powered Pool Lifts, with revisions through September 29, 2017

Reason:

Accessibility to public pools and spas is required by the American Disabilities Act and the International Building Code. Underwriters Laboratories (UL) has developed a new ANSI standard for pool and spa lifts that provides electrical and mechanical loading requirements, and complies with the prescriptive requirements in ANSI/ICC A117.1.

This proposal is submitted by the ICC Plumbing/Mechanical/Gas Code Action Committee (PMG CAC). The PMG CAC was established by the ICC Board of Directors to pursue opportunities to improve and enhance the International Codes or portions thereof that were under the purview of the PMG CAC. In 2017 the PMG CAC held one face-to-face meeting and 11 conference call meetings. Numerous interested parties attended the committee meetings and offered their input.

Cost Impact

The code change proposal will not increase or decrease the cost of construction .

This proposal will not increase the cost of construction because no additional labor, materials, equipment, appliances or devices are mandated beyond what is currently required by the code.

Analysis: A review of the standard proposed for inclusion in the code, UL 60335-2-1000 September 29, 2017, with regard to the ICC criteria for referenced standards (Section 3.6 of CP#28) will be posted on the ICC website on or before April 2, 2018.

Internal ID: 558

SP14-18

ISPSC: 105.1, 307.2.5 (New), Chapter 11

Proponent: Jennifer Hatfield, J. Hatfield & Associates, PL, representing Association of Pool & Spa Professionals (jhatfield@apsp.org)

2018 International Swimming Pool and Spa Code

Add new text as follows:

307.2.5 Plaster. The plastering of pools and permanently installed concrete spas shall be in accordance with APSP/NPC/ICC-12.

Revise as follows:

[A] 105.1 When required. Any owner, or owner's authorized agent who desires to construct, enlarge, alter, repair, move, or demolish a pool or spa or to erect, install, enlarge, alter, repair, remove, convert or replace any system, the installation of which is regulated by this code, or to cause any such work to be performed, shall first make application to the code official and obtain the required permit for the work. A permit shall not be required for replastering or resurfacing of an existing pool or spa.

Add new standard(s) follows:

APSP

Error creating auto-diffed output.
(0x1)

The Association of Pool & Spa
Professionals
2111 Eisenhower Avenue, Suite 500
Alexandria VA 22314

ANSI/APSP/NPC/ICC 12 - 16:

American National Standard for the Plastering of Swimming Pools

Reason:

The Association of Pool & Spa Professionals, in conjunction with the National Plasters Council and ICC have developed the ANSI/APSP/NPC/ICC-12 American National Standard for the Plastering of Swimming Pools. This Standard provides clear requirements when plastering a swimming pool or a permanently installed concrete spa, in both residential and commercial settings. A proposal to add it to the reference standard list will also occur during the Group B cycle.

Plastering is the final coating applied to the shell of a concrete pool or spa. White is the most common, but it can be tinted to other colors by using pigmented aggregate. Pool plaster adds a watertight seal and makes the surface of the pool smoother for contact with swimmers than the underlying rough concrete shell. The pool plaster is a key element for the aesthetic and overall enjoyment of the pool or spa and this standard will ensure that it is applied properly.

The addition of the language under Section 105.1 is to ensure that there is no confusion as to how this standard would be applied upon its adopting into the ISPSC. The intent of the standard was never to require a permit for a replaster of an existing pool or spa; rather, it is for new construction.

Cost Impact

The code change proposal will not increase or decrease the cost of construction .

This proposal will not increase the cost of construction; rather, it will help ensure a proper plaster was put on the pool, decreasing the costs to consumers associated with having to redo a bad plaster job.

Analysis: A review of the standard proposed for inclusion in the code, APSP/NPC/ICC-12- 16, with regard to the ICC criteria for referenced standards (Section 3.6 of CP#28) will be posted on the ICC website on or before April 2, 2018.

Internal ID: 1758

SP15-18

ISPSC: 311.3, 311.3.1 (New), 311.3.2 (New)

Proponent: Jennifer Hatfield, J. Hatfield & Associates, PL, representing Association of Pool & Spa Professionals (jhatfield@apsp.org)

2018 International Swimming Pool and Spa Code

Revise as follows:

311.3 Water velocity. ~~The water velocity in return lines suction and return piping shall comply with either Section 311.3.1 or 311.3.2. The water velocity in copper and copper alloy piping shall not exceed 8 feet-fps (2.4 m) per second. The mps). All water velocity in suction piping shall be as required by Section 310.~~ calculations shall be based on the design flow rate specified for each recirculation system.

311.3.1 Public pools and spas. For public pools and spas, suction piping water velocity shall not exceed 6 fps (1.8 mps) and return piping water velocity shall not exceed 8 fps (2.4 mps).

311.3.2 Residential pools and spas. For residential pools and spas, the water velocity in suction piping and return piping shall not exceed 8 fps (2.4 mps).

Reason:

The proposed changes clarify water velocity related requirements by locating them in one location, Section 311.3.

Return piping water velocity limits are addressed in Section 311.3 of all versions of the ISPSC code, while suction piping water velocity limits are addressed in APSP 7 - 2006 (referenced in ISPSC-2012 only), but not APSP 7 - 2013 (referenced by ISPSC 2015 and 2018).

This was a technical reference glitch associated with the transfer of APSP-16, standard for suction outlet fitting assemblies moving from the American Society of Mechanical Engineers (ASME) to the Association of Pool and Spa Professionals (APSP). The suction piping water velocity provided in this proposal did not change and remains consistent with ANSI/APSP-1, -2, -3 and -5, pool and spa construction standards as well as the CDC's Model Aquatic Health Code (MAHC).

Cost Impact

The code change proposal will increase the cost of construction .

This proposal will increase the cost of construction because additional labor and materials beyond what is currently required by the code. Specifically, in some cases, the suction piping might have to be larger in order to control the velocity through the suction piping.

Internal ID: 1763

SP16-18

ISpsc: 316.2, TABLE 316.2, TABLE 316.2(2) (New), 316.4, 316.6, 316.6.1, 316.6.2, 316.6.3 (New), Chapter 11

Proponent: Michael Savage, representing Code Compliance Action Committee (msavage@rrnm.gov)

2018 International Swimming Pool and Spa Code

Revise as follows:

316.2 ~~Listed and labeled~~ Certification. Heaters and hot water storage tanks shall be listed and labeled in accordance with the applicable standard indicated in Table 316.2(1). Hot water heating systems and components shall comply with the applicable standard ~~listed indicated~~ in Table ~~316.2-316.2(2).~~

**TABLE 316.2(1)
WATER HEATERS**

DEVICE	STANDARD
Electric water heater	UL 1261, UL 1563 or CSA C22.2 No. 218.1
Gas-fired water heater	ANSI Z21.56/CSA 4.7a
Heat pump water heater	UL 1995, AHRI 1160, CSA C22.2 No. 236

Add new text as follows:

**TABLE 316.2(2)
WATER HEATING SYSTEMS AND COMPONENTS**

SYSTEM	STANDARD
<u>Solar water heater</u>	<u>ICC/APSP 902/SRCC 400</u>

316.4 Installation. Heaters shall be installed in accordance with the manufacturer's specifications and the International Fuel Gas Code, International Mechanical Code, International Energy Conservation Code, NFPA 70 or International Residential Code, as applicable in accordance with Section 102.7.1. ~~Solar thermal-water heaters~~ heating systems shall be installed in accordance with Section 316.6.

316.6 ~~Solar thermal-water heaters~~ heaters systems. ~~Solar thermal heaters~~ water heating systems utilized for pools and spas shall comply with Sections 316.6.1 through ~~316.6.2-316.6.3.~~

316.6.1 Installation. Solar thermal water heaters shall be installed in accordance with the International Mechanical Code or International Residential Code, as applicable in accordance with Section 102.7.1.

316.6.2 ~~Collectors and panels~~ Certification of collectors. Solar thermal collectors ~~and panels~~ shall be listed and labeled in accordance with ICC 901/SRCC 100 ~~or ICC 900/SRCC 300.~~ ~~Collectors and panels shall be permanently marked with the manufacturer's name, model number, and serial number. Such markings shall be located on each collector in a position that is readily viewable after installation of the collector or panel.~~

316.6.3 Marking of Collectors and modules. Solar thermal collectors and photovoltaic modules shall be permanently marked with the manufacturer's name, model number, and serial number. Such markings shall be located on each collector in a position that is readily viewable after installation.

Add new standard(s) follows:

ICC

International Code Council, Inc.
500 New Jersey Avenue, NW 6th
Floor
Washington DC 20001

ICC 902/APSP 902/SRCC 400-2018:

Solar Pool and Spa Heating System Standard

Reason:

SRCC has recently completed a standard titled ICC/APSP 902/SRCC 400 (“SRCC 400”), Solar Pool and Spa Heating System Standard. This standard addresses full solar pool heating systems, not just the collectors. Previously the code cited ICC 901/SRCC 100 for solar thermal collectors and ICC 900/SRCC 300 for systems. While ICC 900/SRCC 300 included solar pool heating systems in its scope, they were not addressed in the 2015 edition. Therefore, no standards were in place for solar pool heating systems (except the collectors) in the ISPSC. The insertion of the new standard fills this gap and removes ICC 900/Standard 300, which does not contain any material for pools.

The new standard also addresses a wide range of safety topics related to these systems including material compatibility, high temperature and suction entrapment safety. These are of particular importance since solar pool heating systems are often retrofitted to existing pools and spas, and therefore are not integrated by the original recirculation system designer. It is critical to ensure that they do not degrade the performance or safety of the pool itself, or introduce new hazards.

The SRCC 400 standard allows for the use of solar water heating using photovoltaic modules. These modules are electrical rather than thermal. As a consequence, the term “solar thermal water heaters” has been replaced with the universal phrase “solar water heating systems” throughout the proposal. The new term addresses both thermal and photovoltaic systems in a manner consistent with the standard. Additionally, the term “panel” has been changed to more universal term “module” to properly refer to these devices.

Existing Table 316.2 has been re-cast as two separate tables. New Table 316.2(1) (modified existing table 316.2) proposes to reference the appropriate standards for factory-built, appliance-type water heaters that can be wholly listed and labeled to demonstrate compliance. In contrast, new Table 316.2(2) addresses water heating systems with solar water heaters, which are generally, but not always, site-assembled. Heat exchangers, a component of water heating systems, are addressed in Table 316.2(2) along with the reference to the new SRCC 400 standard.

The titles of Sections 316.2 and 316.6.2 have been changed to make each consistent with terminology used in the ISPSC, specifically Section 1001.4. Section 316.6 is modified to reflect the use of SRCC 400. Section 316.6 also has been broken into multiple sections to enhance clarity.

Cost Impact

The code change proposal will increase the cost of construction .

Any costs of certification will be borne by the heater and collector manufacturers. This may marginally increase the cost of heaters and panels. Pool system manufacturers participated in the creation of the standard and are aware of the potential certification cost implications.

Analysis: A review of the standard proposed for inclusion in the code, ICC 902/APSP 902/SRCC 400-2018, with regard to the ICC criteria for referenced standards (Section 3.6 of CP#28) will be posted on the ICC website on or before April 2, 2018.

Internal ID: 1383

SP17-18

ISPSC: Table 316.2, Chapter 11

Proponent: Jonathan Roberts, UL LLC, representing UL LLC (jonathan.roberts@ul.com)

2018 International Swimming Pool and Spa Code

Revise as follows:

**TABLE 316.2
WATER HEATERS**

DEVICE	STANDARD
Electric water heater	UL 1261, UL 1563 or CSA C22.2 No. 218.1
Gas-fired water heater	ANSI Z21.56/CSA 4.7a
Heat exchanger	AHRI 400
Heat pump water heater	AHRI 1160 <u>and one of the following:</u> UL 1995, CSA C22.2 No. 236 <u>or</u> <u>UL/CSA 60335-2-40</u>

Add new standard(s) follows:

UL

UL LLC
333 Pfingsten Road
Northbrook IL 60062

UL/CSA 60335-2-40-17:

Standard for Safety for Household and Similar Electrical Appliances - Safety - Part 2-40: Particular Requirements for Electrical Heat Pumps, Air-Conditioners and Dehumidifiers.

Reason:

The UL Standard for Safety for Heating and Cooling Equipment, UL 1995 will be phased out by the year 2020, and will be replaced by UL 60335-2-40, the Standard for Safety for Household and Similar Electrical Appliances, Part 2-40: Particular Requirements for Electrical Heat Pumps, Air-Conditioners and Dehumidifiers. UL 60335-2-40 is harmonized with requirements in Canada and Europe. These requirements include provisions for the most current technology and use of flammable refrigerants, and is currently being used to list new products.

The word "or" is added where there are multiple standards for different types of heaters, because only one standard needs to be used, except for AHRI 1160. AHRI 1160 is a performance standard, not a safety standard.

Reference:

[http://ahrinet.org/App_Content/ahri/files/standards%20pdfs/ANSI%20standards%20pdfs/ANSI_AHRI_Standard_1160_\(I-P\)-2014.pdf](http://ahrinet.org/App_Content/ahri/files/standards%20pdfs/ANSI%20standards%20pdfs/ANSI_AHRI_Standard_1160_(I-P)-2014.pdf)

Cost Impact

The code change proposal will not increase or decrease the cost of construction .

For new products, there will not be a cost increase. For existing products, manufacturers will need to have those products evaluated to the new requirements.

Analysis: A review of the standard proposed for inclusion in the code, UL 60335-2-40-17, with regard to the ICC criteria for referenced standards (Section 3.6 of CP#28) will be posted on the ICC website on or before April 2, 2018.

Internal ID: 429

SP18-18

ISPSC: 317.1

Proponent: John Kelly, Iowa Department of Public Health, representing self

2018 International Swimming Pool and Spa Code

Revise as follows:

317.1 General. This section applies to devices and systems that induce or allow air to enter ~~pools and~~ spas either by means of a powered pump or passive design.

Reason:

As originally written the ISPSC was allowing devices and systems that induce or allow air to enter pools. Air that is entrained in the water obscures the visibility into the water as light is refracted.

While air is allowed in spas, the depth of spas is more closely regulated and the patrons are intended to be walking into and seated while the spa is in use. Generally the duration of the air is also limited by a timer at which point visibility into the spa is returned as the air dissipates.

Where hydrotherapy jets have been installed in pools it has been observed that the air introduced through the jets can obscure the visibility into large portions of the pool and the jets typically never shut down. The patrons may be able to walk or depending on the depth they may need to swim. It has been observed that the hydrotherapy jets in pools can induce a current making it difficult for young children to safely return to the side/handhold of the pool.

In the definition of air induction system it means a system where air is introduced into hollow ducting built into a spa floor, bench, or hydrotherapy jets. A pool was not included in the definition of an air induction system.

Cost Impact

The code change proposal will decrease the cost of construction .

This proposal would strike "pool" from the general requirements for air blower and air induction systems. This aligns the code requirements with the definition. This would decrease the construction cost by the cost of the air blowers or air induction system which vary significantly based by the size and scope of the project from several hundred dollars to tens of thousand of dollars.

Internal ID: 1408

SP19-18

ISPSC: 319, 319.2, 508, 508.1

Proponent: Jennifer Hatfield, J. Hatfield & Associates, PL, representing Association of Pool & Spa Professionals (jhatfield@apsp.org)

2018 International Swimming Pool and Spa Code

Revise as follows:

SECTION 319 SANITIZING EQUIPMENT AND CHEMICAL FEEDERS

319.2 Chemical feeders. ~~Where installed, chemical~~ Public pools and spas shall be equipped with chemical feed equipment such as flow-through chemical feeders, electrolytic chemical generators, mechanical chemical feeders, chemical feed pumps, and automatic controllers that are listed and labeled in compliance with NSF 50. Chemical feed systems shall be installed in accordance with the manufacturer's specifications. Chemical feed pumps shall be wired so that they cannot operate unless there is adequate return flow to disburse the chemical throughout the pool or spa as designed.

Delete without substitution:

~~SECTION 508 SANITIZING, OXIDATION EQUIPMENT AND CHEMICAL FEEDERS~~

~~508.1 Automatic controllers.~~ ~~Where an automatic controller is installed on a spa or hot tub for public use, the controller shall be installed with an automatic pH and an oxidation-reduction potential controller *listed and labeled* in compliance with NSF 50.~~

Reason:

The changes clarify that chemical feeder systems are required in public pools and spas and what type of systems are allowed. The change then removes what is found in Chapter 5 as it would contradict the new language in Section 319.

The addition of the chemical feeder requirement is consistent with the Model Aquatic Health Code.

Bibliography:

See section 4.7.3 of the Model Aquatic Health Code

<https://www.cdc.gov/mahc/editions/current.html>

Cost Impact

The code change proposal will increase the cost of construction .

For jurisdictions that do not currently require chemical feed systems in public pools and spas, this would increase the cost by requiring such systems.

Internal ID: 1526

SP20-18

ISPSC: 321.2.3

Proponent: John Kelly, representing self (john.kelly@idph.iowa.gov)

2018 International Swimming Pool and Spa Code

Revise as follows:

321.2.3 Underwater lighting. Underwater lighting shall provide not less than 8 horizontal foot-candles (8 lamp lumens per square foot) [86 lux] at the pool water surface area, or not less than a total wattage of $\frac{3}{2}$ watt/ft² (5.4 watts/m²) of pool water surface for incandescent underwater lighting where the fixtures and lamps are rated in watts/area.

Exception: The requirement of this section shall not apply where overhead lighting provides not less than 15 foot-candles (15 lumens per square foot) [161 lux] of *maintained illumination* at the pool water surface, the overhead lighting provides visibility, without glare, of all areas of the pool, and the requirements of Section 321.2.2 are met or exceeded.

Reason:

It is unnecessary and inconsistent to provide separate requirements (watts/sqft) for incandescent lighting versus (lamp lumens/sqft) for other forms of lighting as both incandescent lighting and other forms of lighting (i.e. LED lighting) are rated based on the light output of the lamp in lumens. Historically the total installed wattage of the underwater lighting was used as it was more easily measured, but as more efficient lighting (i.e. LED's, etc.) have become available the light output of the lamps in lumens has replaced requirements based on wattage as the light output is more relevant.

As originally written in the code, the requirement for the underwater lighting establishes a minimum lighting level in footcandles at the pool water surface. Overhead lighting is designed to provide a minimum lighting level (i.e. footcandles) at the pool water surface, as a significant amount of the light directed at the water surface penetrates the water surface to light the bottom and sides of the pool. Please note however that the underwater lighting is already located below the water surface and it is undesirable to direct the underwater lighting at the water surface, rather it is designed to be directed at the pool walls and the bottom of the pool. The design for underwater lighting is not based on a minimum light level (i.e. footcandles) at the water surface, rather it is designed based on the total installed lamp output in lumens divided by the area of the pool in square feet and is generally provided through multiple lights positioned evenly around the pool to light the walls and floor of the swimming pool. The requirement should be updated to avoid confusion and require a minimum total lamp lumens of the installed underwater lighting divided by the total water surface area in square feet.

As examples, the Bibliography refers to underwater lighting requirements in the Model Aquatic Health Code (MAHC) and Iowa Swimming Pool and Spa rules.

Bibliography:

Iowa Administrative Code-Swimming Pools and Spas

https://idph.iowa.gov/Portals/1/userfiles/120/641_15.pdf Page 35, Para. (2),k,(1)

2016 Model Aquatic Health Code

<https://www.cdc.gov/mahc/pdf/2016-mahc-code-final.pdf> Page 87 Para. 4.6.1.5.1

Cost Impact

The code change proposal will decrease the cost of construction .

The code as written would require more lighting as it is requiring 8 footcandles (lumen per square foot) at the water surface rather than simply a total of 8 lamp lumens per square foot of pool water surface area. The intent of underwater lighting is not to light the water surface, rather the lighting should be directed at the pool walls and bottom.

Internal ID: 1439

SP21-18

ISPSC: 322.3.1

Proponent: Jennifer Hatfield, J. Hatfield & Associates, PL, representing Association of Pool & Spa Professionals (jhatfield@apsp.org)

2018 International Swimming Pool and Spa Code

Revise as follows:

322.3.1 Wall clearance. There shall be a clearance of not less than 3 inches (76 mm) and not greater than ~~6~~4 inches (~~152~~101.6 mm) between the pool wall and the ladder.

Reason:

This change is being proposed to address safety concerns, as a smaller opening will help prevent arms and legs from getting stuck behind the rails. The 4 inch max standard is the same for railings, fences, playground equipment, etc.

Cost Impact

The code change proposal will not increase or decrease the cost of construction .

This change should not increase or decrease the cost of construction as some manufacturers of ladders will only have to make a small adjustment to the design of their product so that when the product is installed, the ladder can comply with the revised maximum allowance of wall clearance.

Internal ID: 1518

SP22-18

ISPSC: SECTION 202, 202 (New), SECTION 324 (New), 324.1 (New), 324.2 (New), 324.3 (New), 324.4 (New), 324.5 (New), 324.6 (New), 324.7 (New), 324.7.1 (New), 324.7.2 (New), 324.7.2.1 (New), 324.8 (New), 324.8.1 (New), 324.8.1.2 (New), 324.8.2 (New), 324.8.2.1 (New), 324.8.2.2 (New), 324.8.2.3 (New), 324.9 (New), 324.9.1 (New), 324.9.2 (New), 324.10 (New), 324.11 (New), 324.12 (New)

Proponent: Jennifer Hatfield, J. Hatfield & Associates, PL, representing Association of Pool & Spa Professionals (jhatfield@apsp.org)

2018 International Swimming Pool and Spa Code

SECTION 202 DEFINITIONS

Add new definition as follows:

CHEMICAL STORAGE SPACE A space in an aquatic facility used for the storage of pool or spa chemicals such as acids, salt, or corrosive or oxidizing chemicals.

EQUIPMENT ROOM A space intended for the operation of pool pumps, filters, heaters, and controllers. This space is not intended for the storage of hazardous pool or spa chemicals.

INDOOR AQUATIC FACILITY A physical place that contains one or more pools or spas and the surrounding bather and spectator/stadium seating areas within a structure that meets the definition of building in the International Building Code. It does not include equipment, chemical storage, or bather hygiene rooms or any other rooms with a direct opening to the aquatic facility. Also known as a natatorium.

Add new text as follows:

SECTION 324 EQUIPMENT ROOMS

324.1 General. The provisions of this section apply to public pools and spas and aquatic recreation facilities.

324.2 Requirements. The equipment area or room floor shall be of concrete or other suitable material having a smooth slip resistant finish and have positive drainage, including a sump drain pump, if necessary. Floors shall have a slope toward the floor drain and/or sump drain pump adequate to prevent standing water at all times. The opening to the equipment room or area shall be designed to provide access for all anticipated equipment. At least one hose bibb with backflow preventer shall be located in the equipment room or be accessible within an adequate distance of the equipment room so that a hose can service the entire room.

324.3 Construction. The size of the equipment room or area shall provide working space to perform routine operations and equipment service. Equipment rooms also intended for storage shall have adequate space provided for such storage, without reducing the working spaces. Equipment rooms or areas shall be lighted to provide 30 foot candles (323 lux) of illumination at floor level.

324.4 Electrical. All electrical wiring shall be installed in accordance with NFPA 70.

324.5 Ventilation. Equipment room ventilation shall address:

1. Combustion requirements,
2. Heat dissipation from equipment,
3. Humidity from surge or balance tanks,
4. Ventilation to the outside, and
5. Air quality.

324.6 Markings. All piping in the equipment room shall be permanently identified by its use and the pool or spa it serves. Identification shall be provided for:

1. Main drains and skimmer lines,
2. Filtered water,
3. Make-up water,

4. Chlorine (or disinfection) feeds.
5. Acid (or pH) feeds.
6. Compressed air lines.
7. Gutter lines.
8. Chemical sample piping, and
9. Pool heating lines.

All piping shall be marked with directional arrows as necessary to determine flow direction and all valves shall be clearly identified by number with a brass tag, plastic laminate tag or permanently affixed alternate. Valves shall be described as to their function and referenced in the operating instruction manual.

324.7 Separation from Chemical Storage Spaces. Combustion equipment, air-handling equipment, and electrical equipment shall not be exposed to air contaminated with corrosive chemical fumes or vapors. Spaces containing combustion equipment, air handling equipment, and/or electrical equipment and spaces sharing air distribution with spaces containing such equipment shall not be used as chemical storage spaces at the same time unless the equipment is listed and labeled for use in that atmosphere. Spaces containing combustion equipment, air handling equipment, or electrical equipment and spaces sharing air distribution with spaces containing such equipment shall be isolated from chemical storage space air.

324.7.1 Doors and openings. A door or doors shall not be installed in a wall between such equipment rooms and an interior chemical storage space. There shall be no ducts, grilles, pass-throughs, or other openings connecting such equipment rooms to chemical storage spaces, except as permitted by the International Fire Code. Spaces containing combustion equipment, air-handling equipment, and/or electrical equipment and spaces sharing air distribution with spaces containing such equipment shall be isolated from indoor aquatic facility air unless the equipment is listed for the atmosphere. There shall be no ducts, grilles, pass-throughs, or other openings connection such spaces to an indoor aquatic facility. Ducts which connect the indoor aquatic facility to the duct connections of air handlers shall not be construed as connecting the air-handler space to the indoor aquatic facility unless HVAC equipment is rated for indoor aquatic facility atmosphere and serves only that indoor aquatic facility. Where building construction leaves any openings or gaps between floors and walls, or between walls and other walls, or between walls and ceilings, such gaps shall be permanently sealed against air leakage.

324.7.2 Indoor Aquatic Facility Access. Where a door or doors are installed in a wall between an equipment room and an indoor aquatic facility, the floor of the equipment room shall slope back into the equipment room in such a way as to prevent any equipment room spills from running under the door into the indoor aquatic facility. This requirement shall be accomplished by one of the following:

1. A floor all of which is at least 4 inches below the level of the nearest part of the indoor aquatic facility floor.
2. A continuous dike not less than 4 inches high located entirely within the equipment room, which will prevent spills from reaching the indoor aquatic facility floor.

324.7.2.1 Automatic closer and lock. A door between an equipment room and an indoor aquatic facility shall be equipped with an automatic closer and automatic lock. The door, frame, and automatic closer shall be installed so as to ensure that the door closes completely and latches without human assistance. The automatic lock shall require a key or combination to open from the indoor aquatic facility side. The lock shall be designed and installed to be opened by one hand from the inside of the room under all circumstances, without the use of a key or tool. Such doors shall be equipped with permanent signage warning against unauthorized entry. All sides of such doors shall be equipped with a gasket. The gasket shall be installed to prevent the passage of air, fumes, or vapors when the door is closed.

324.8 Chemical storage space. A least one space dedicated to chemical storage space shall be provided to allow safe storage of pool and spa chemicals. In all chemical storage spaces, an emergency eyewash station shall be provided. The construction of a chemical storage space shall take into account foreseeable hazards and protect the stored materials against tampering, wild fires, unintended exposure to water and the transfer of fumes into any interior space of a building intended for occupation. Any walls, floors, doors, ceilings, and other building surfaces of an interior chemical storage space shall join each other tightly. If chemicals are to be stored outdoors, they shall be stored in a well-ventilated protective area with an installed barrier to prevent unauthorized access. Exterior chemical storage spaces not joined to a wall of a building shall be completely enclosed by fencing that is at least 6 feet high. Fencing shall be equipped with a self-closing and self-latching gate having a permanent locking device.

324.8.1 Chemical storage space doors. All doors opening into chemical storage spaces shall be equipped with

permanent signage:

1. Warning against unauthorized entry, and
2. Specifying the expected hazards, and
3. Specifying the location of the associated safety data sheet forms, and
4. Product chemical hazard NFPA chart.

Where a single door is the only means of egress from a chemical storage space, the door shall be equipped with an emergency-egress device. Where a chemical storage space door must open to an interior space, spill containment shall be provided to prevent spilled chemicals from leaving the chemical storage space and the door shall not open to a space containing combustion equipment, air-handling equipment, or electrical equipment.

324.8.1.2 Interior opening. Where a chemical storage space door must open to an interior space, such door shall have all of the following requirements:

1. Constructed of corrosion-resistant materials.
2. Equipped with a corrosion-resistant, automatic lock to prevent unauthorized entry.
 - 2.1. Such lock shall require a key or combination to open from the outside into the chemical storage space.
 - 2.2. Such lock shall be designed and installed as to be capable of being opened by one hand from the inside of the chemical storage space without the use of a key or tool.
3. Supported on corrosion-resistant hinges, tracks, or other supports.
4. Equipped with suitable gaskets or seals on the top and all sides to minimize air leakage between the door and the door frame.
5. Equipped with a floor or threshold seal to minimize air leakage between the door and the floor or threshold.
6. Equipped with an automatic door closer that will completely close the door and latch without assistance and close the door completely against the specified difference in air pressure.
7. Equipped with a limit switch and an alarm that will sound if the door remains open for more than 30 minutes. The alarm shall have a minimum output level of 85 dbA at 10 feet.

324.8.2 Interior chemical storage spaces. There shall be no transfer grille, pass-through grille, louver, or other device or opening that will allow air movement from the chemical storage space into any other interior space of a building intended for occupancy or into another chemical storage space. Interior chemical storage spaces that share any building surface with any other interior space shall be equipped with a ventilation system that operates continuously and insures that all air movement is from all other interior space and toward the chemical storage space. Interior chemical storage spaces that share an electrical conduit system with any other interior space shall be equipped with a ventilation system that operates continuously and insures that all air movement is from all other interior spaces and toward the chemical storage space. This pressure difference shall be maintained by a continuously operated exhaust system used for no other purpose than to remove air from that one chemical storage space. Where more than one chemical storage space is present, a separate exhaust system shall be provided for each chemical storage space. The exhaust airflow rate shall be the amount specified in the International Mechanical Code. The function of this exhaust system shall be monitored continuously by an audible differential-pressure alarm system which shall sound if the specified differential air pressure is not maintained for a period of thirty minutes. This alarm shall have a minimum output level of 85 dbA at 10 feet and shall require manual reset to silence it.

324.8.2.1 Air ducts in interior chemical storage spaces. No duct shall allow air movement from the chemical storage space into any other interior space of a building intended for occupation or into any other chemical storage space. Air ducts shall not enter or pass through an interior chemical storage space unless it is a corrosion-resistant duct used for no other purpose than to exhaust air from the chemical storage space. This corrosion-resistant duct must exhaust to the exterior and must end at a point on the exterior of the building, at least 20 feet from any air intake for breathing air, cooling air, or combustion air. A duct used for no other purpose than to supply makeup air to the chemical storage area shall be acceptable. This makeup air supply duct must end at a point on the exterior of the building, at least 20 feet from any air intake for breathing air, cooling air, or combustion air. Any other ducts specifically allowable by the International Mechanical Code where such ducts are corrosion-resistant and joint-free to the extent feasible shall be acceptable.

324.8.2.2 Pipes and tubes in interior chemical storage spaces. Pipes and tubes shall not enter or pass

through an interior chemical storage space.

Exceptions:

1. As required to service devices integral to the function of the chemical storage space, such as pumps, vessels, controls, freeze protection, and safety devices.
2. As required to allow for automatic fire suppression.
3. As required for drainage.

Piping, tubes, drain bodies, grates, and attachment and restraint devices shall be corrosion-resistant and rated for the chemical environment(s) present including floor drain bodies and grates. All wall penetrations shall be sealed air-tight and commensurate with the rating of the wall assembly. Sealing materials shall be compatible with the wall assembly and the chemical environment(s) present.

324.8.2.3 Combustion equipment in interior chemical storage. No combustion device or appliance shall be installed in a chemical storage space, or in any other place where it will be exposed to the air from a chemical storage space.

Exceptions: A combustion device or appliance which meets all of the following requirements shall be acceptable:

1. The device or appliance is required for one or more processes integral to the function of the room, such as space heat, and
2. The device is listed for such use, and
3. The device as installed is approved.

324.9 Ozone rooms. An ozone equipment room shall not be used for storage of chemicals, solvents, or any combustible materials, other than those required for the operation of the recirculation and ozone generating equipment. Rooms which are designed to include ozone equipment shall be equipped with an emergency ventilation system capable of 6 air changes per hour. The exhaust intake shall be located 6 inches from the floor, on the opposite side of the room from the make-up air intake. The emergency ventilation system shall be so arranged as to run on command of an ozone-leak alarm or on command of a manual switch. The manual emergency ventilation switch shall be located outside the room and near the door to the ozone room. Ozone rooms which are below grade shall be equipped with force-draft ventilation capable of 6 changes per hour. The exhaust intake shall be located 6 inches from the floor, on the opposite side of the room from the make-up air intake. Such ventilation shall be so arranged as to:

1. Run automatically concurrent with the ozone equipment and for at least a time allowing for 15 air changes after the ozone equipment is stopped,
2. Run upon activation of the ozone detection and alarm system, and
3. Run on command of a manual switch.

The manual ventilation switch shall be located outside the room and near the door to the ozone room.

324.9.1 Signage. In addition to the signs on all chemical storage areas, a sign shall be posted on the exterior of the entry door, stating "DANGER - GASEOUS OXIDIZER -- OZONE" in lettering not less than 4 inches high.

324.9.2 Alarm system. Rooms containing ozone generation equipment shall be equipped with an audible and visible ozone detection and alarm system. The alarm system shall consist of both an audible alarm capable of producing at least 85 decibels at 10 feet distance and a visible alarm consisting of a flashing light mounted in plain view of the entrance to the ozone-equipment room. The ozone sensor shall be located at a height of 18-24 inches above floor level. The ozone sensor shall be capable of measuring ozone in the range of 0-2 ppm. The alarm system shall alarm when the ozone concentration equals or exceeds 0.1 ppm in the room. Activation of the alarm system shall shut off the ozone generating equipment and turn on the emergency ventilation system.

324.10 Gaseous chlorination space. Use of compressed chlorine gas shall be prohibited for new construction and after substantial alteration to existing facilities.

324.11 Windows. When installed in an interior wall, ceiling, or door of a chemical storage space, such window shall have the following components:

1. Tempered or plasticized glass,
2. A corrosion-resistant frame, and
3. Incapable of being opened or operated.

When installed in an exterior wall or ceiling, such window shall:

1. Be mounted in a corrosion-resistant frame and
2. Be so protected by a roof, eave, or permanent awning as to minimize the entry of rain or snow in the event of window breakage.

324.12 Sealing and blocking materials. Materials used for sealing and blocking openings in an interior chemical storage space shall:

1. Minimize the leakage of air, vapors, or fumes from the chemical storage space,
2. Be compatible for use in the environment, and
3. Commensurate with the fire rating assembly in which they are installed.

Reason:

The ISPSC has no detailed requirements for equipment rooms, chemical storage facilities, etc. The proposal provides the requirements found in the Model Aquatic Health Code in order to have consistency between the codes.

Further, major aspects of public pool and spa, and aquatic recreational facility construction are missing in the current ISPSC. Providing these types of additions may encourage a jurisdiction that currently finds the public pool portion of the ISPSC as deficient, to adopt this code in its entirety.

Bibliography:

Section 4.9 of the Model Aquatic Health Code

<https://www.cdc.gov/mahc/editions/current.html>

Cost Impact

The code change proposal will increase the cost of construction .

If a jurisdiction does not already have equipment and chemical storage room requirements for public facilities, then these changes could increase the cost of construction.

Internal ID: 1528

SP23-18

ISPSC: 324 (New), 324.1 (New), Chapter 11

Proponent: Jennifer Hatfield, J. Hatfield & Associates, PL, representing Association of Pool & Spa Professionals (jhatfield@apsp.org)

2018 International Swimming Pool and Spa Code

Add new text as follows:

324 INDOOR AIR QUALITY

324.1 General. Indoor pool and spa air handling system design, construction, and installation shall comply with ASHRAE 62.1.

Add new standard(s) follows:

ASHRAE ASHRAE 62.1-2016 Ventilation for Acceptable Air Quality

Reason:

By requiring air handling systems to be designed and installed in compliance with ASHRAE Standard 62.1 2013, Ventilation for Acceptable Indoor Air Quality, an indoor pool or spa will have minimum ventilation rates to ensure the indoor air quality is acceptable to human occupants so to minimize adverse health effects.

This also provides consistency with the Model Aquatic Health Code published by the Centers for Disease Control and Prevention, which requires compliance with the ASHRAE Standard when addressing indoor pool or spa air handling systems.

Bibliography:

See sections 4.2.2.3.3 & 4.6.2 of the Model Aquatic Health Code, which reference and require compliance with the ASHRAE 62.1 Standard.

<https://www.cdc.gov/mahc/editions/current.html>

Cost Impact

The code change proposal will not increase or decrease the cost of construction .

The code change proposal will not increase or decrease the cost of construction because these indoor pool facilities already have to meet the ASHRAE 62.1 Standard. This simply aligns the ISPSC with what is already required via other codes, including the MAHC.

Analysis: The referenced standard, ASHRAE 62.1-2016, is currently referenced in the 2018 IMC.

Internal ID: 1514

SP24-18

ISPSC: 402.13, 402.14

Proponent: John Kelly, Iowa Department of Public Health, representing self

2018 International Swimming Pool and Spa Code

Revise as follows:

402.13 Ladders ~~Stairways~~ for diving equipment. ~~Ladders Stairways shall be provided with two grab rails or two handrails. There shall be a uniform distance between ladder treads, with a 7-inch to access diving equipment. Stair riser heights shall be 7 inches (178 mm) minimum distance and a 12-inch (305 mm) maximum distance. maximum and 4 inches (102 mm) minimum with a minimum tread depth of 11 inches. Handrails shall be provided with a handrail height measured vertically from the leading edge of tread nosing of not less than 34 inches (864 mm) and not more than 38 inches (965 mm). Guards shall be located along open sided stairs. Required guards shall not be less than 42 inches (1067 mm) high measured vertically from the leading edge of tread nosing. Required guards shall not have openings which allow passage of a sphere 4 inches (102 mm) in diameter from the walking surface to the required guard height.~~

Exception: ~~The distance between treads for the top and bottom riser can vary but shall be not less than 7 inches (178 mm) and not greater than 12 inches (305 mm).~~

Exception: Diving boards shall be permitted to be accessed to by a ladder provided that the diving board is located not greater than 39 inches (1000 mm) above the deck and the ladder has two grab rails or two handrails.

402.14 Springboard fall protection guards. ~~Springboards located at a height greater than 5-feet-39 inches (1524-1000 mm) above the pool deck shall have a fall protection guard on each side of the springboard. The design and the selection of the materials of construction of the fall protection guards shall be determined by the manufacturer of the springboard support structure. The installation and maintenance of the fall protection guards shall be in accordance with the fall protection guard manufacturer's instructions. springboard to the point at which the board cantilevers over the water. Required guards shall be not less than 42 inches (1067 mm) high measured vertically from the diving board surface. Required guards shall not have openings which allow passage of a sphere 4 inches (102 mm) in diameter from the diving board to the required height.~~

Reason:

Fixed vertical ladders are not an appropriate method for access to 3 meter diving stands. They present an unreasonable and unnecessary risk of injury due to falls from the ladders and boards to the concrete swimming pool deck below contributing to deaths and other significant injuries particularly among children.

Ladders should not be used without proper footwear and/or if wet or contaminated with oils. Aquatic environments are generally wet the patrons are barefoot and their bodies are often covered by oils (i.e. sunscreen).

Fixed ladder use is typically restricted to areas that allow access by worker for maintenance such as roof access, radio masts, wind turbines, industrial machines, and underground shafts and pits.

The International Building Code only allows a fixed lass as one of two required exits at heliports, boiler, incinerator and furnace rooms and also for egress at stage (technical production areas) and for emergency escape from a window well.

The DOL recognizes the hazards associated with falls from ladders and prohibit young workers (14 and 15 years olds) from jobs requiring the use of ladders.

The CPSC recognized injuries associated with falls from diving boards and in 1996 set up a meeting with industry representatives to encourage the industry to consider voluntary standards requiring the use of resilient surfacing similar to that found in playground standards.

ASTM standards relating to aquatic facilities such as ASTM F2376 (Waterslides) and ASTM F2461 (Aquatic Play

Equipment) require stairs or ramps complete with guardrails and handrails to provide access and egress from platforms that are more than 21 inches above the surrounding terrain.

Two attachments have been included. One of the attachments includes news articles of injuries or deaths associated with falls from ladders leading to 3 meter diving boards or from the boards themselves to the pool deck below. The second attachment provides an expanded presentation of the specific hazards associated with vertical ladders.

Bibliography:

See the attachments for any articles or studies referenced

Cost Impact

The code change proposal will increase the cost of construction .

There is an added cost to requiring stairways in lieu of ladders to access diving boards. The cost will may be offset over time by reduced insurance claims and lawsuits associated with significant injuries and deaths associated with falls from the ladders.

Internal ID: 1358

SP25-18

ISPSC: 405.7 (New)

Proponent: John Kelly, Iowa Department of Public Health, representing self

2018 International Swimming Pool and Spa Code

Add new text as follows:

405.7 Barrier. Where a wading pool is within 50 feet of a swimming pool, the wading pool shall have a barrier separating the wading pool from the swimming pool. Such barrier shall comply with Sections 305.2.1 through 305.7.

Reason:

The intent of a wading pool is to provide young non-swimmers access to recreational water of a depth they can stand in and that does not require swimming. Direct access to swimming pools by these young non-swimmers increase the risk of drowning.

Where a wading pool is adjacent to a swimming pool they should be separated by sufficient distance to intercept a child before reaching the swimming pool and/or a physical barrier to prevent the child from reaching the swimming pool.

The Iowa Swimming Pool and Spa Rules (see Bibliography) requires that if a wading pool is within 50 feet of a swimming pool the wading pool shall have a barrier separating it from the swimming pool. These separation distances or physical barriers restrict the young non-swimmers from accessing the swimming pool to reduce the risk of drowning.

The ISPSC should adopt requirements establishing a minimum separation distance and/or physical barriers between swimming pools and wading pools.

Bibliography:

Iowa Administrative Code

Swimming Pools and Spas

https://idph.iowa.gov/Portals/1/userfiles/120/641_15.pdf Page 34, Para. (5),i,(4)

Cost Impact

The code change proposal will increase the cost of construction .

Providing a barrier or increasing the separation distance between a wading pool and an adjacent swimming pool will increase the cost of construction to reduce the risk of drowning among young non-swimmers.

Internal ID: 1799

SP26-18

ISPSC: 407.3 (New), 407.3.1 (New)

Proponent: Jennifer Hatfield, J. Hatfield & Associates, PL, representing Association of Pool & Spa Professionals (jhatfield@apsp.org)

2018 International Swimming Pool and Spa Code

Add new text as follows:

407.3 Continuous water removal. The design of a gutter system shall accommodate continuous removal of water from the pool's upper surface at a rate of not less than 125 percent of the required total recirculation flow rate as determined by the design professional.

407.3.1 Gutter outlets. At a gutter flow condition of not less than 125 percent of the total recirculation flow as determined by the design professional, gutter outlets such as drop boxes, converters, return piping, or flumes shall be designed to prevent flooding of the gutter that would result in skimmed water re-entering the pool.

Reason:

A value of 125 percent of the total recirculation flow rate chosen by the designer is recommended for hydraulic flexibility. As patrons swim, play, dive and splash, they create waves that exceed the normal recirculation one might see when the pool is empty. Upsizing the gutter system allows capture of the waves without flooding the gutter, which would make the gutter ineffective. This does not apply to suction piping. Proposed 407.3 and 407.3.1 only apply to gutter systems.

This is consistent with the requirements found in the Model Aquatic Health Code and many state public pool code requirements.

Bibliography:

See sections 4.7.1.4.2.1 and 4.7.1.4.3 of the Model Aquatic Health Code

<https://www.cdc.gov/mahc/editions/current.html>

Cost Impact

The code change proposal will increase the cost of construction .

In a jurisdiction that does not already require gutter systems to follow this design criteria, it could increase the cost, but this simply aligns with requirements found in many jurisdictions today.

Internal ID: 1525

SP27-18

ISPSC: 407.3 (New), 407.3.1 (New), 407.3.2 (New), 407.3.3 (New), 407.3.4 (New)

Proponent: Jennifer Hatfield, J. Hatfield & Associates, PL, representing Association of Pool & Spa Professionals (jhatfield@apsp.org)

2018 International Swimming Pool and Spa Code

Add new text as follows:

407.3 Pool circulation. The filtration circulation system shall be designed with sufficient flexibility to achieve a hydraulic apportionment that will ensure effective distribution of treated water throughout the pool.

407.3.1 Inlets. Effective distribution of treated water shall be accomplished by either a continuous perimeter overflow system with integral inlets or by means of directionally adjustable inlets adequate in design, number, and location.

407.3.2 Adequate mixing. Pools shall have wall or floor inlets or both to provide for adequate mixing. Inlets shall be hydraulically sized to provide the design flow rates for each area of the pool proportional to the turnover rate and the area covered by the inlet.

407.3.3 Floor inlets. Floor inlets shall be required for pools that are greater than 50 feet (15.2 m) width. The spacing between floor inlets shall not exceed 20 feet (6.1 m). Pools having only floor inlets shall have such inlets located within 15 feet (4.6 m) of the perimeter waterline. Where wall inlets are used in combination with floor inlets, the floor inlets shall be located not greater than 25 feet (7.6 m) from the nearest side walls.

407.3.4 Wall inlets. The spacing between wall inlets shall not exceed 20 feet (6.1 m), measured along the perimeter water line.

Reason:

The ISPSC public pool requirements do not currently include detailed guidelines for assuring adequate in-pool distribution of sanitizers and filtered water. The proposal provides directional inlet requirements found in APSP-15 and additional spacing details from the Model Aquatic Health Code in order to have consistency between the codes and APSP standards.

Further, this is a major aspect of public pool circulation system performance missing in the current ISPSC. Providing these types of additions may encourage a jurisdiction that currently finds the public pool portion of the ISPSC as deficient, to adopt this code in its entirety.

Bibliography:

Section 4.7.1.3 of the Model Aquatic Health Code

<https://www.cdc.gov/mahc/editions/current.html>

Cost Impact

The code change proposal will increase the cost of construction .

The proposal will increase the cost of construction where a jurisdiction does not already have inlet spacing requirements that require as many inlets as this new language requires.

Internal ID: 2324

SP28-18

ISPSC: 409.5 (New), 409.5.1 (New)

Proponent: John Kelly, Iowa Department of Public Health, representing self

2018 International Swimming Pool and Spa Code

Add new text as follows:

409.5 Rope and float line. A rope and float line shall be provided for all of the following situations:

1. Separation of activity areas
2. Identification of a break in floor slope at water depths of less than 5 ft (1524 mm).
3. Identification of a water depth greater than 3 ft (914 mm).
4. Identification of a water depth greater than 5 ft (1524 mm).

409.5.1 Location. The rope and float line shall be located 1 foot (305 mm) toward the shallow end in each location.

Reason:

As currently written it does not appear that the ISPSC has any requirements for rope and float lines at pools public pools regulated under Chapter 4. The ISPSC does require rope and float lines in pools regulated under Chapter 6 and in residential pools regulated under Chapter 8.

Rope and float lines are a common safety element required in swimming pools to mark a change of pool floor slope, and to segregate different users, activities, and water depths. The proposal is based on adding requirements to Chapter 4 that are similar to the requirements for pools regulated under Chapter 6.

This includes a float line to mark the separation of activity areas, to mark a break in floor slope at water depths of less than 5 ft, to mark water depth greater than 3 ft, and to mark the transition to deep water at 5 ft.

The float lines at 3 ft and 5 ft mark the limits of the water depths at which most drowning incidents in pools occur (see attachment). The float line at 3 ft provides a visible physical marker to aid parents and lifeguards keeping children in water depths more appropriate to their size and abilities.

Cost Impact

The code change proposal will increase the cost of construction .

Adding float lines will slightly increase the cost of construction.

Internal ID: 1661

SP29-18

ISPSC: 410.1

Proponent: John Kelly, Iowa Department of Public Health, representing self

2018 International Swimming Pool and Spa Code

Revise as follows:

410.1 Toilet Dressing space, cleansing showers and toilet facilities. ~~Class A and B pools~~ Cleansing showers and toilet facilities shall be provided with toilet facilities having the required number of plumbing fixtures in accordance with Section 609 and shall be installed in accordance with the International Building Code or the International Plumbing Code. A dressing space or room shall be provided. Cleansing showers and dressing spaces shall be either separate from or within toilet facilities.

Exception: Pools accessory to dwelling units or sleeping units of Group R-1 or R-2 occupancies shall not be required to be provided with dressing areas or cleansing showers.

Reason:

As currently written it appears the ISPSC does not reference the minimum required plumbing fixtures of the IBC/IPC, rather it only is referencing only the plumbing fixtures found within toilet facilities. This would leave out other relevant requirements such as drinking fountains and service sinks. The requirements of the IBC/IPC are the appropriate requirements for the minimum required plumbing fixtures and are based on the occupancy type and design occupant load and are widely accepted, applied, and proven across many different jurisdictions for various occupancy type and design occupant loads. The ISPSC should remain consistent with the requirements of the IBC/IPC for the minimum number of plumbing fixtures.

For some reason while it appears that the requirement for showers has been included for Aquatic Recreation Facilities under Chapter 6 it appears it has been omitted for competition pools, public pools, and instruction, play, or therapy pools under Chapter 4. Given that many patrons share a common body of water in swimming pools, in addition to the plumbing fixtures required by the IBC/IPC, it is appropriate to require both cleansing showers and rinse showers to reduce the transmission of recreational water illnesses and to reduce the development of chloramines. The requirement for showers at public pools under Chapter 4 and aquatic recreational facilities under Chapter 6 should be consistent as they present similar risks. It is appropriate to allow pools serving living units (i.e. hotels, apartments, etc.) to be exempt from the requirement for dressing areas and cleansing showers as the patrons can take a cleansing shower and get dressed in the comfort and privacy of their living unit on-site. (The IBC Group Classifications for R-1 and R-2 are shown at the end of this reason statement.)

The Model Aquatic Health Code (MAHC) provides requirements for the number of cleansing showers under section 4.10.4.2.1 and rinse showers under section 4.10.4.3.1. As the number of showers are related to health concerns associated with transmission of recreational water illnesses and the health effects associated with chloramines, the ISPSC should be changed to be consistent with the requirements of the MAHC in relation to the minimum number of showers required. A separate proposal aligned the number of required showers for Aquatic Recreational Facilities with the requirements of the Model Aquatic Health Code. This proposal ensures that requirements remain consistent between Chapter 4 and Chapter 6.

310.2 Residential Group R-1. Residential Group R-1 occupancies containing *sleeping units* where the occupants are primarily *transient* in nature, including:

- Boarding houses (transient)* with more than 10 occupants
- Congregate living facilities (transient)* with more than 10 occupants
- Hotels (transient)*
- Motels (transient)*

310.3 Residential Group R-2. Residential Group R-2 occupancies containing *sleeping units* or more than two *dwelling units* where the occupants are primarily permanent in nature, including:

- Apartment houses
- Congregate living facilities (nontransient)* with more than 16 occupants
 - Boarding houses (nontransient)*
 - Convents
 - Dormitories*
 - Fraternities and sororities
 - Monasteries
- Hotels (nontransient)
- Live/work units*
- Motels (nontransient)
- Vacation timeshare properties

Cost Impact

The code change proposal will increase the cost of construction .

The proposal will increase the cost of construction at facilities that did not already provide showers for their swimming pools. Showers at competitive pools, public pools, instructional and therapy pools are needed to reduce the risk for transmission of recreational water illnesses and the development of chloramines.

Internal ID: 1673

SP30-18

ISPSC: 411.2.1, 411.2.2, 411.2.3

Proponent: John Kelly, Iowa Department of Public Health, representing self

2018 International Swimming Pool and Spa Code

Revise as follows:

411.2.1 Tread dimensions and area. Treads shall be not less than 24 inches (607 mm) wide at the leading edge. Treads shall have an unobstructed surface area of not less than ~~240-264~~ square inches (0.154-0.170 m²) and ~~an a~~ uniform unobstructed horizontal depth of not less than ~~10-11~~ inches (254-279 mm) at the centerline.

411.2.2 Risers. Risers, except for the bottom riser, shall have a uniform height of not greater than ~~12-7~~ inches (305-178 mm) and not less than 4 inches (102 mm) measured at the centerline. The bottom riser height is allowed to vary to the floor.

411.2.3 Top tread. The vertical distance from the pool coping, deck, or step surface to the uppermost tread shall be not greater than ~~12-7~~ inches (305-178 mm).

Reason:

The tread riser heights and tread depths requirements in the ICC IBC & ISPSC are inconsistent. The tread riser heights allowed in the ISPSC are excessive and the allowable tread depths have been reduced from that found in the IBC which together will increase the risks of slips, trips, and falls at the stairs in swimming pools and spas.

The 12 in. riser height currently allowed in the ISPSC far exceeds the 7 in riser maximum height found in the ICC and even exceeds the maximum 9.5 in. riser height allowed by OSHA under 1910.25(c)(2) for walking and working surfaces in general industry.

A study (see attachment) on stairway falls has found that risers higher than 7.5 in. require excessive energy for most people to climb and may increase loss of balance when descending. This is compounded by reduced tread depths and a lack in uniformity of the tread riser heights and tread depths.

For swimming pools and spas this is further compounded due to the reduce friction available at the stairs due to their wetted condition and potential for biofilm and/or algae growth on the stairs themselves.

The requirements relating to the stair riser heights and tread depths within the ISPSC shall be changed to be consistent with the requirements found in the IBC. The 12 in. maximum riser height currently allowed in the ISPSC is excessive and will contribute to injuries from slips, trips, and falls at swimming pool and spa stairs particularly among children, elderly, and overweight patrons.

Bibliography:

Cohen, J., LaRue, C. S., & Cohen, H. H. (2009). Stairway falls: An ergonomics analysis of 80 cases. Professional Safety, 54, 1, 27-32.

<http://www.nsc.org/ConventionsDocuments/TSCE/Tools-Resources/Stairway-Falls-Cohen.pdf>

OSHA

https://www.osha.gov/pls/oshaweb/owadis.show_document?p_table=STANDARDS&p_id=9717 Para. 1910.25(b)(3)

Cost Impact

The code change proposal will increase the cost of construction .

Reducing the tread riser height and increasing the tread depth will theoretically increase the number of treads required by code and the associated cost. In practice the tread risers and tread depths commonly observed in new public swimming pools and spas more closely match that as proposed rather than those allowed in the ISPSC so I would anticipate minimal cost impact for all but the smallest spas.

Internal ID: 140

SP31-18

ISPSC: 411.1.3

Proponent: John Kelly, Iowa Department of Public Health, representing self

2018 International Swimming Pool and Spa Code

Revise as follows:

411.1.3 Deep area. The means of entry and exit in the deep area of pools shall consist of one of the following:

1. Steps/stairs.
2. Ladders.
3. Grab rails with recessed treads.
4. Ramps. Swimouts
5. ~~Beach entries.~~
6. ~~Swimouts.~~
7. ~~Other designs that provide the minimum utility as specified in this code.~~

Reason:

In deep water the ramp or beach entry would not terminate at the bottom of the pool as in shallow water, but would end at the pool wall with an abrupt drop off to the bottom of the pool in deep water. Ramps are undefined in the code. The code addresses beach entry which is defined as a sloping entry. Beach entries or sloping entries are commonly used for patrons in wheel chairs to entry the pool. If beach or sloping entries were allowed in deep water this could allow a wheel chair to drop off into the bottom of the pool in the deep water.

The requirements for shallow end beach and sloping entries are addressed under 411.3. There are no requirements listed for deep water. If the requirements of 411.3 were applied to deep water, it would require a handrail at the vertical drop as the sloping entry reached the pool wall. This would render the entry unusable as it would be blocked off. If the requirements of 411.3 were not applied to deep water, there would not be limits to the slopes of the entry or requirement that it be slip resistant which would create a slip, trip, and falls hazard.

Cost Impact

The code change proposal will decrease the cost of construction .

Beach entries or ramps would be more costly to provide entry to or exiting from deep water than stairs, ladders, recessed treads, or swimouts.

Internal ID: 1655

SP32-18

ISPSC: 411.2.5 (New)

Proponent: Jennifer Hatfield, J. Hatfield & Associates, PL, representing Association of Pool & Spa Professionals (jhatfield@apsp.org)

2018 International Swimming Pool and Spa Code

Add new text as follows:

411.2.5 Outlined Edges. The leading horizontal and vertical edges of stair treads shall be outlined with slip-resistant contrasting tile or other permanent marking of not less than 1 inch (25.4 mm) and not greater than 2 inches (50.8 mm).

Reason:

Provides for additional safety for a patron when entering or exiting a public swimming pool. Conforms with the requirement found in the Model Aquatic Health Code.

Bibliography:

See section 4.5.4.2 of the Model Aquatic Health Code, <https://www.cdc.gov/mahc/editions/current.html>

Cost Impact

The code change proposal will increase the cost of construction .

A slight increase in cost could occur when providing slip-resistance contrasting tile or some other permanent marking.

Internal ID: 1517

SP33-18

ISPSC: 411.2.5 (New)

Proponent: John Kelly, Iowa Department of Public Health, representing self

2018 International Swimming Pool and Spa Code

Add new text as follows:

411.2.5 Handrails. A handrail shall be provided for each set of stairs. Stairs wider than 5 ft (1.5 m) shall have at least one additional handrail for every 12 ft (3.7 m) of stair width. Handrails at pool stairs shall comply with Section 323.2.

Reason:

Handrails are required at stairs to prevent injuries from slips, trips, and falls. Currently the ISPSC required handrails at steps on the deck but overlooked the steps into the pool. Falls are more likely on stairs leading into the pool than on the deck as currently the code allows greater riser heights and reduced tread depths on the stairs leading into the pool. This is further compounded by reduced coefficient of friction on the wetted pool stairs and on conditions that are favorable for the growth of biofilms and/or algae on pool stairs.

Requiring one handrail for each 12 ft in width was based on the requirements found in the Model Aquatic Health Code

Cost Impact

The code change proposal will increase the cost of construction .

Added a requirement for a handrail. Cost for a handrail in the neighborhood of \$200 and up depending on stair configuration. A handrail is necessary at the stairs to reduce injuries from slips, trips, and falls at the stairs.

Internal ID: 2260

SP34-18

ISPSC: 411.3.3

Proponent: John Kelly, Iowa Department of Public Health, representing self

2018 International Swimming Pool and Spa Code

Revise as follows:

411.3.3 Surfaces. Beach and sloping entry walking surfaces at water depths up to 36 inches (914 mm) shall be ~~of slip-resistant materials~~resistant.

Reason:

Submerged walking surfaces in pools must be constructed with a slip resistant surface to reduce slips, trips and falls. The wetted walking surfaces begin with a reduced coefficient of friction and this is further compounded as conditions can be favorable for the growth of biofilms and algae. The 3 ft depth was chosen to be consistent with the requirements of the Model Aquatic Health Code (see attachment)

Bibliography:

2016 Model Aquatic Health Code

<https://www.cdc.gov/mahc/pdf/2016-mahc-code-final.pdf> Page 63 Para. 4.2.1.8

Cost Impact

The code change proposal will increase the cost of construction .

The cost will increase as more of the bottom of the pool will be required to be slipresistant. The cost is minimal as some materials of construction are naturally slipresistant but some require the addition of treatment to the finishes.

Internal ID: 2275

SP35-18

ISPSC: 411.5.1

Proponent: John Kelly, Iowa Department of Public Health, representing self

2018 International Swimming Pool and Spa Code

Revise as follows:

411.5.1 Swimouts. Swimouts ~~, located in either the deep or shallow area of a pool,~~ shall comply with all of the following:

1. The horizontal surface shall be not greater than 20 inches (508 mm) below the waterline.
2. An unobstructed surface shall be provided that is equal to or greater than that required for the top tread of the pool stairs in accordance with Section 411.2.
3. ~~Where used as an entry and exit access, swimouts~~ Swimouts shall be provided with steps and handrails that comply with the pool stair requirements of Section 411.2 and Section 411.2.323.2.
4. The leading edge shall be visibly set ~~apart~~ apart by a stripe having a width of not less than 3/4 inch (19 mm) and not greater than 2 inches (51 mm). The stripe shall be of a contrasting color to the adjacent surfaces.

Reason:

Clarified and simplified language and coordinated language for swimouts at public pools addressed under Chapter 4 and Chapter 6. Clarified the need for a handrail at the stairs from a swimout.

Cost Impact

The code change proposal will increase the cost of construction .

Added a requirement for a handrail. Cost for a handrail in the neighborhood of \$200 and up depending on stair configuration. A handrail is necessary at the steps from a swimout to reduce injuries from slips, trips, and falls at the stairs.

Internal ID: 1594

SP36-18

ISPSC: 411.5.2

Proponent: John Kelly, Iowa Department of Public Health, representing self

2018 International Swimming Pool and Spa Code

Revise as follows:

411.5.2 Underwater seats and benches. Underwater seats and benches, whether used alone or in conjunction with pool stairs, shall comply with all of the following:

1. The horizontal surface of the bench shall be not greater than 20 inches (508 mm) below the waterline.
2. An unobstructed surface shall be provided that is not less than 10-16 inches (406 mm) in depth and not greater than 22 inches (559 mm) in depth and not less than 24-26 inches (607-660 mm) in width.
3. Underwater seats and benches shall not be used as the required for entry and exit access.
4. ~~Where underwater seats are located in the deep area of the pool where manufactured or constructed diving equipment is installed, such seats shall be located outside of the minimum diving water envelope for diving equipment.~~ Underwater benches shall only be located in areas where the pool water depth does not exceed 5 ft (1.5 m).
5. The leading edge shall be visually set apart by a stripe having a width of not less than 3/4 inch (19 mm) and not greater than 2 inches (51 mm). The stripe shall be of a contrasting color to the adjacent surfaces.
6. ~~The horizontal surface shall be at or below the waterline.~~ The top surface of the bench shall be slip resistant.
7. ~~A tanning ledge or sun shelf used as the required entry and exit access shall be located not greater than 12 inches (305 mm) below the waterline.~~

Reason:

This proposal addresses dimensions of underwater seats and benches and their location. It also removes references to "tanning ledge" or "sun shelf" as they are undefined but clearly are not within the intent for of not underwater seats and benches as benches can not be used as a required entry/access where it appears based on the stricken language that the shelves are allowed to serve as an entry/exit.

It is not clear where the 10 inch bench surface originated as that would have been too small for patrons. The dimensions were updated based on anthropometric data for men and woman to ensure that dimensions of an underwater bench was large enough for patron use for seating as intended.

The proposal clarified that benches not only couldn't count toward a required point of access but that the shall not be used for entry and exits. While the surface is required to be slip resistant, the step from the bench surface to the deck it too large and there is no handrail so it would be unsafe to step to or from the deck.

The proposal also attempted to align the marking requirements for benches at public pools under Chapter 4 and Chapter 6.

Finally, the benches were restricted to a maximum pool depth of 5 feet to be consistent with the requirements of the Model Aquatic Health Code (MAHC) . The Annex of the MAHC states:

"4.5.16.3 Maximum Water Depth. The five foot (1.5 m) depth restriction is to address the potential SAFETY issue of stepping or otherwise moving off a bench into deep water. The seat depth below the water line is limited to 20 inches (50.8 cm) maximum so a non-swimmer may be comfortable at that depth but once they move from the bench into a greater water depth it may exceed their comfort and/or skill level."

Bibliography:

Excerpts from :Gordon, Claire C. et. al 1988 Anthropometric Survey of U.S. Personnel: Summary Statistics Interim Report. March 1989.

<https://multisite.eos.ncsu.edu/www-ergocenter-ncsu-edu/wp-content/uploads/sites/18/2016/06/Anthropometric->

Cost Impact

The code change proposal will increase the cost of construction .

This proposal increases the size of the benches based on anthropometric data so they better can serve their intended purpose. It also clarifies the marking required for the benches. In both cases there were cost associated with forming the bench and marking the bench so the cost associated with the clarification of the marking of the bench and the depth and width of the bench would be minimal.

Internal ID: 1592

SP37-18

ISPSC: 411.5.2

Proponent: John Kelly, Iowa Department of Public Health, representing self

2018 International Swimming Pool and Spa Code

Revise as follows:

411.5.2 Underwater seats and benches. Underwater seats and benches, whether used alone or in conjunction with pool stairs, shall comply with all of the following:

1. The horizontal surface shall be not greater than 20 inches (508 mm) below the waterline.
2. An unobstructed surface shall be provided that is not less than 10 inches (254 mm) in depth and not less than 24 inches (607 mm) in width.
3. Underwater seats and benches shall not be used as the required entry and exit access.
4. Where underwater seats are located in the deep area of the pool where manufactured or constructed diving equipment is installed, such seats shall be located outside of the minimum diving water envelope for diving equipment.
5. The leading edge shall be visually set apart.
6. The horizontal surface shall be at or below the waterline.
7. ~~A tanning ledge or sun shelf used as the required entry and exit access shall be located not greater than 12 inches (305 mm) below the waterline.~~

Reason:

Currently a tanning ledge or sun shelf is undefined in the ISPSC. It is clear however that a tanning ledge or sun shelf is not an underwater seat or bench. As such they should not be included under the section providing requirements for underwater seat or benches. Underwater seats and benches are not designed for standing and walking and be the code shall not be used as the required entry and exit access, but as written a tanning ledge or sun shelf can be used as the required entry and exit. This is in conflict with 411.1.2 which limits the means of entry and exit from shallow water to stairs, a ramp, or a beach entry and 411.1.3.

Under 401.5 the slope of the floor in the shallow area of a pool is limited based on the pool type. While a bench is not the floor of the pool (i.e. not intended to walk on), there are a few states that allow tanning ledges or sun shelves in which the floor of the pool abruptly drops off from a depth of approximately 12 inches to depths typically ranging from 3 ft to 5 ft. This abrupt change in slope of the bottom of the pool violated the sloping requirements of 401.5, creates an unsafe walking surface, creates a visual obstruction obscuring view of the bottom of the swimming pool and the abrupt change in depth presents a drowning hazard particularly to young non-swimmers that are at the highest risk of drowning in a swimming pool. See attachment for additional information.

If a tanning ledge or sun shelf is to be included in the ISPSC, they should be defined so the intent is clear and a new section should be added with the provisions necessary to protect the safety of the patrons.

Cost Impact

The code change proposal will decrease the cost of construction .

Tanning shelves increase the cost of construction.

Internal ID: 1795

SP38-18

ISPSC: 503.2

Proponent: John Kelly, Iowa Department of Public Health, representing self

2018 International Swimming Pool and Spa Code

Revise as follows:

503.2 Multilevel seating. Where multilevel seating is provided, the maximum water depth of any seat or sitting bench shall be ~~28-26~~ inches (~~711-660~~ mm) measured from the *design waterline* to the lowest measurable point.

Reason:

The 28 inch depth is too deep for seating. The sitting shoulder height of a 99th percentile male is only 26.16 inches and the sitting shoulder height of a 99th percentile woman is only 24.54 inches.

Bibliography:

Excerpts from :Gordon, Claire C. et. al 1988 Anthropometric Survey of U.S. Personnel: Summary Statistics Interim Report. March 1989.

<https://multisite.eos.ncsu.edu/www-ergocenter-ncsu-edu/wp-content/uploads/sites/18/2016/06/Anthropometric-Detailed-Data-Tables.pdf> Page 3

Cost Impact

The code change proposal will not increase or decrease the cost of construction .

This proposal only sets the limit on depth of seating so there would not be an impact to the construction cost.

Internal ID: 2063

SP39-18

ISPSC: 504.2 (New)

Proponent: John Kelly, representing self (john.kelly@idph.iowa.gov)

2018 International Swimming Pool and Spa Code

Add new text as follows:

504.2 Timer. The operation of the hydrotherapy jets shall be limited by a cycle timer having a maximum setting of 15 minutes. The cycle timer shall be located not less than 5 feet away, adjacent to, and within sight of the spa.

Reason:

The ISPSC allows spas to operate at a temperature of up to 104 degrees F. The elevated temperature allowed for spas increases the risk of deaths from hyperthermia and drowning and the jet currents further increase the heat transfer rate.

A study on "The Health Hazards of Saunas and Spas and How to Minimize Them" noted that many people should limit their stays in spas to 5 or 10 minutes and that even healthy adults would be well advised not to stay in spas for more than 10 to 15 minutes.

Under Section 4.12.1.10 of the Model Aquatic Health Code the agitation system shall be connected to a timer to limit the cycle to 15 minutes. This is consistent with requirements found in many state and local health codes.

The ISPSC should recognize the risk of hyperthermia particularly with the elevated temperatures it allows for spas and given the increased heat transfer created by the hydrotherapy jets and limit the jet cycle accordingly and consistent with the Model Aquatic Health Code.

Bibliography:

The Health Hazards of Saunas and Spas and How to Minimize Them

Edward Press, MD, MPH <https://www.ncbi.nlm.nih.gov/pmc/articles/PMC1405706/pdf/amjph00208-0084.pdf>

American Journal of Public Health, August 1991, Volume 81, No. 8

2016 Model Aquatic Health Code, 2nd Edition, July 2016

U.S. Department of Health and Human Services, Centers for Disease Control and Prevention

<https://www.cdc.gov/mahc/pdf/2016-mahc-code-final.pdf>

Cost Impact

The code change proposal will increase the cost of construction .

The Model Aquatic Health Code and most state and local health codes already contain a requirement for a timer so for most areas there will be no added cost. In areas with no state or local requirement there would be a small cost associated with the installation of the timer. Including the requirement within the ISPSC will provide consistency in the requirements and help address the risk in those areas where no health codes are in place.

Internal ID: 178

SP40-18

ISPSC: 509.2

Proponent: John Kelly, Iowa Department of Public Health, representing self

2018 International Swimming Pool and Spa Code

Revise as follows:

509.2 Operational signs. Operational signs shall include, but not be limited to, the following messages as required by the local jurisdiction:

- ~~1.~~ Children under age 5 and persons using alcohol or drugs that cause drowsiness shall not use spas.
- ~~2.~~ Pregnant women and persons with heart disease, high blood pressure or other health problems should not use spas without prior consultation with a health provider.
- ~~3.~~ Children under 14 years of age shall be supervised by an adult.
- ~~4.~~ Use of the spa when alone is prohibited (if no lifeguards on site).
- ~~1-5.~~ Do not allow the use of or operate spa if the suction outlet cover is missing, damaged or loose.
- ~~2-6.~~ Check spa temperature before each use. Do not enter the spa if the temperature is above 104°F (40°C).
- ~~3-7.~~ Keep breakable out of the spa area.
- ~~4-8.~~ Spa shall not be operated during severe weather conditions.
- ~~5-9.~~ Never place electrical appliances within 5 feet (1524 mm) of the spa.
- ~~6-10.~~ No diving.

Reason:

The spa signage currently required by the ISPSC does not contain any language warning those particularly vulnerable to injury or death associated with the elevated temperature of the spa.

The spa signage in the Model Aquatic Health Code (see attachment) places warnings and restrictions on those that are particularly vulnerable to the elevated temperature of a spa. The annex of the Model Aquatic Health Code notes that "Small children are still developing internal temperature regulation, and infants in particular have a small body mass compared to body surface area." It also notes that spa seating is not designed to accommodate younger children in a seated position. As such children under the age of 5 should not use a spa and children under the age of 14 should be supervised by an adult.

A study on health hazards of spas (see attachment) noted that when analyzing deaths associated with spas the chief risk factors identified were alcohol ingestion, heart disease, seizure disorders, and cocaine ingestion. These factors accounted for about 45% of the fatalities. It further noted that 61 of the 151 spa related deaths occurred in children under 12 years of age.

Bibliography:

The Health Hazards of Saunas and Spas and How to Minimize Them

Edward Press, MD, MPH <https://www.ncbi.nlm.nih.gov/pmc/articles/PMC1405706/pdf/amjph00208-0084.pdf>

American Journal of Public Health, August 1991, Volume 81, No. 8

2016 Model Aquatic Health Code

<https://www.cdc.gov/mahc/pdf/2016-mahc-code-final.pdf> Page 281, Para. 6.4.2.2.4

Cost Impact

The code change proposal will not increase or decrease the cost of construction .

The signage is already required. The proposal only changes what it stated on the sign.

Internal ID: 2084

SP41-18

Proponent: John Kelly, Iowa Department of Public Health, representing self

2018 International Swimming Pool and Spa Code

Delete without substitution:

~~**603.3 Shallow-to-deep-end rope and float line.** Where a pool has a water depth ranging from less than 5 feet (1524 mm) to greater than 5 feet (1524 mm), a rope and float line shall be located 1 foot (305 mm) horizontally from the 5-foot (1524 mm) depth location, toward the shallow end of the pool.~~

Reason:

Ropes and float line requirements are addressed under section 605.2. Creating additional rope and float line requirements in a separate section creates confusion and one or the other requirements will more likely be overlooked. Based on the requirements it appears that for type D-2 pools a rope line would be required at both 4-1/2 ft depth under 605.2.3 and 5 ft depth under 603.3. If the pool is sloping at 1 ft vertically in 12 ft horizontally there would be only 6 ft between these two required float lines.

Cost Impact

The code change proposal will decrease the cost of construction .

This proposal eliminates the duplication of the requirements for float lines which are addressed in both section 603.3 and section 605.2.

Internal ID: 1558

SP42-18

ISPSC: 605.2

Proponent: John Kelly, Iowa Department of Public Health, representing self

2018 International Swimming Pool and Spa Code

Revise as follows:

605.2 Rope and float line. A rope and float line shall be provided for all of the following situations:

1. Separation of activity areas.
2. Identification of a break in floor slope at water depths of less than 5 feet (1524 mm).
3. Identification of a water depth greater than ~~4¹/₂~~ 3 feet (~~1372-914~~ mm) in constant floor slope in Class D-2 pools.
4. Identification of a water depth greater than 5 ft (1524 mm).

Exception: Class D-1 pools or any other pool where the ~~designer~~ code official indicates that such a ~~line is not required or that the line would constitute a hazard.~~

Reason:

Rope and float lines are a common safety element required in swimming pools to mark a change of pool floor slope, and to segregate different users, activities, and water depths. The proposal is based on combining the requirements for rope and float lines into a single section.

This includes a float line to mark the separation of activity areas, to mark a break in floor slope at water depths of less than 5 ft, to mark water depth greater than 3 ft, and to mark the transition to deep water at 5 ft.

The float lines at 3 ft and 5 ft mark the limits of the water depths at which most drowning incidents in pools occur (see attachment). The float line at 3 ft provides a visible physical marker to aid parents and lifeguards keeping children in water depths more appropriate to their size and abilities.

Cost Impact

The code change proposal will not increase or decrease the cost of construction .

The change only combines the requirements for rope and float lines into a single section and shifts the location of one rope and float line.

Internal ID: 1556

SP43-18

ISPSC: SECTION 609, 609.1, 609.2, 609.2.1, 609.2.2, 609.3, 609.3.1, 609.3.2, 609.3.3, 609.4, 609.4.1, 609.7

Proponent: John Kelly, Iowa Department of Public Health, representing self

2018 International Swimming Pool and Spa Code

Revise as follows:

SECTION 609 TOILET ROOMS DRESSING AND BATHROOMS SANITARY FACILITIES

609.1 General. ~~Toilet Dressing and bath sanitary~~ sanitary facilities shall be provided in accordance with the minimum requirements of the International Building Code and International Plumbing Code and Sections 609.2 through 609.9.~~609.9.~~

609.2 Number of fixtures. ~~Pools shall have toilet facilities with the number of fixtures in accordance with Section 609.2.1 or 609.2.2.~~ The minimum number of required water closets, urinals, lavatory, and drinking fountain fixtures shall be provided as required by the International Building Code and International Plumbing Code and the dressing facilities and number of cleansing and rinse showers shall be provided in accordance with Sections 609.2.1, 609.2.2, and 609.3.1.

609.2.1 Water area less than ~~7500~~ 4000 square feet. Facilities that have less than ~~7500~~ 4000 gross square feet (~~697-372~~ m²) of water area available for bather access shall have dressing facilities and not less than ~~one water closet for males, one urinal for males, one lavatory for males, one~~ one cleansing shower for males, ~~two water closets for females, one lavatory for females and one~~ cleansing shower for females.

609.2.2 Water area ~~7500~~ 4000 square feet or more. Facilities that have ~~7500~~ 4000 gross square feet (~~697-372~~ m²) or more of water area available for bather access shall have dressing facilities and not less than ~~0.7 water closet for males, one urinal for males, 0.85 lavatory for males, one~~ one cleansing shower for males, ~~two water closets for females, one lavatory for females and one~~ cleansing shower for females for every 7500-4000 square feet (~~697-372~~ m²) or portion thereof. Where the result of the fixture calculation is a portion of a whole number, the result shall be rounded up to the nearest whole number.

609.3 Showers. Showers shall be in accordance with Sections 609.3.1 through ~~609.3.5~~ 609.3.5.

609.3.1 ~~Deck Rinse~~ shower. ~~Not in addition to the requirement for cleansing showers in 609.2.1 and 609.2.2, not less than one and not more than half of the total number of showers required by Section 609.2~~ rinse shower shall be located ~~provided~~ on the deck of or at the entrance of each pool.

Delete without substitution:

609.3.2 Anti-scald device. ~~Where heated water is provided to showers, the shower water supply shall be controlled by an anti-scald device.~~

609.3.4 Flow rate. ~~Each showerhead shall have a water flow of not less than 2 gallons per minute (7.6 lpm).~~

Revise as follows:

609.3.5 Temperature. At each cleansing showerhead, the heated shower water temperature shall be not less than 90°F (32°C) and not greater than 120°F (49°C). Water supplied to rinse showers shall not be required to be heated.

609.4 Soap dispensers. Soap dispensers shall be in accordance with ~~Sections 609.4.1 and 609.4.2.~~ Section 609.4.1.

609.4.1 Liquid or powder. Soap dispensers shall be provided ~~in each toilet facility, at each lavatory and cleansing shower.~~ Soap dispensers shall dispense liquid or powdered soap. Reusable cake soap is prohibited. Soap dispensers and soap shall not be provided at rinse showers.

609.7 Sanitary napkin receptacles. Sanitary napkin receptacles shall be provided in each water closet compartment for females and in the area of the cleansing showers for female use only.

Reason:

The minimum number of plumbing fixtures required by the IBC/IPC and the ISPSC are inconsistent. The requirements of the IBC/IPC are the appropriate requirements and are based on the occupancy type and design occupant load and are

widely accepted, applied, and proven across many different jurisdictions for various occupancy type and design occupant loads. The ISPSC should be change to be consistent with the requirements of the IBC/IPC.

Given that many patrons share a common body of water in swimming pools and spa, in addition to the plumbing fixtures required by the IBC/IPC, it is appropriate to require both cleansing showers and rinse showers to reduce the transmission of recreational water illnesses and to reduce the development of chloramines.

The Model Aquatic Health Code (MAHC) provides requirements for the number of cleansing showers under section 4.10.4.2.1 and rinse showers under section 4.10.4.3.1. As the number of showers are related to health concerns associated with transmission of recreational water illnesses and the health effects associated with chloramines, the ISPSC should be changed to be consistent with the requirements of the MAHC in relation to the minimum number of showers required.

Bibliography:

2016 Model Aquatic Health Code, 2nd Edition, July 2016

U.S. Department of Health and Human Services, Center for Disease Control and Prevention

<https://www.cdc.gov/mahc/pdf/2016-mahc-code-final.pdf>

Cost Impact

The code change proposal will not increase or decrease the cost of construction .

Typically Swimming Pools and Spas must already meet building code, plumbing code, and health code requirements so it will eliminate confusion caused by inconsistencies between the applicable codes but should not change the number of fixtures installed.

Internal ID: 179

SP44-18

ISPSC: 610.4.4

Proponent: John Kelly, Iowa Department of Public Health, representing self

2018 International Swimming Pool and Spa Code

Revise as follows:

610.4.4 Slip-resistant surfaces. Beach and sloping entry walking surfaces at water depths up to ~~18~~36 inches (~~457~~914 mm) shall be slip resistant.

Reason:

Submerged walking surfaces in pools must be constructed with a slip resistant surface to reduce slips, trips and falls. The wetted walking surfaces begin with a reduced coefficient of friction and this is further compounded as conditions can be favorable for the growth of biofilms and algae.

The 3 ft depth was chosen to be consistent with the requirements of the Model Aquatic Health Code (see attachment)

Bibliography:

2016 Model Aquatic Health Code

<https://www.cdc.gov/mahc/pdf/2016-mahc-code-final.pdf> Page 63 Para 4.2.1.8

Cost Impact

The code change proposal will increase the cost of construction .

The cost will increase as more of the bottom of the pool will be required to be slip resistant. The cost is minimal as some materials of construction are naturally slip resistant but some require the addition of treatment to the finishes.

Internal ID: 2268

SP45-18

ISPSC: 610.5.1, 610.5.2, 610.5.5, 610.5.6

Proponent: John Kelly, Iowa Department of Public Health, representing self

2018 International Swimming Pool and Spa Code

Revise as follows:

610.5.1 Uniform height of 9 inches riser height. Except for the bottom riser, risers at the centerline shall have a maximum uniform height of ~~9-7~~ inches (~~229-178~~ mm) and a minimum uniform height of 4 inches (102 mm). The bottom riser height shall be permitted to vary from the other risers.

610.5.2 Distance from coping or deck. The vertical distance from the pool coping, deck, or step surface to the uppermost tread shall be not greater than ~~9-7~~ inches (~~229-178~~ mm).

610.5.5 Tread horizontal depth. Treads shall have ~~an~~ a uniform unobstructed horizontal depth of not less than 11 inches (279 mm).

610.5.6 Tread surface area. Treads shall have an unobstructed surface area of not less than ~~240-264~~ square inches (~~0.17-0.170~~ m²).

Reason:

As currently written the stair construction requirements within pools at aquatic recreation facilities covered under Chapter 6 do not match the stair construction requirements within pools addressed under Chapter 4, and neither of these requirements match the requirements for stair construction under the IBC. These variations in stair construction increase the risks of slips, trips, and falls at pool stairs.

The 9 inch riser height in Chapter 6 exceed the 7 inch riser height found in the IBC. A study attached has found that risers higher than 7.5 in. require excessive energy for most people to climb and may increase the risk of loss of balance when descending. This is compounded by a lack of requirements for uniform tread depths in Chapter 6.

For swimming pools and spas the risk of slips, trips, and falls, due to irregularity in the stair construction is further compounded due to the reduced friction available at the stairs due to their wetted condition and potential for biofilm and/or algae growth on the stairs themselves.

The requirements relating to stair riser heights and tread depths within the ISPSC shall be changed to be consistent with the requirements found in the IBC. The irregularity of the stair construction based on the current requirements of the ISPSC will increase the risks of slips, trips, and falls associated with the pool stairs.

Bibliography:

Cohen, J., LaRue, C. S., & Cohen, H. H. (2009). Stairway falls: An ergonomics analysis of 80 cases. Professional Safety, 54, 1, 27-32.

<http://www.nsc.org/ConventionsDocuments/TSCE/Tools-Resources/Stairway-Falls-Cohen.pdf>

OSHA

https://www.osha.gov/pls/oshaweb/owadis.show_document?p_table=STANDARDS&p_id=9717 Para. 1910.25(b)(3)

Cost Impact

The code change proposal will increase the cost of construction .

Reducing the tread riser height will theoretically increase the number of treads required by code and the associated cost. In practice the tread risers and tread depths commonly observed in new public swimming pools and spas more closely match that as proposed rather than those allowed in the ISPSC so I would anticipate minimal cost impact for all but the smallest of spas.

Internal ID: 1464

SP46-18

ISPSC: 610.5.7 (New)

Proponent: John Kelly, Iowa Department of Public Health, representing self

2018 International Swimming Pool and Spa Code

Add new text as follows:

610.5.7 Handrails. A handrail shall be provided for each set of stairs. Stairs wider than 5 ft (1.5 m) shall have at least one additional handrail for every 12 ft (3.7 m) of stair width. Handrails at pool stairs shall comply with Section 323.2.

Reason:

Handrails are required at stairs to prevent injuries from slips, trips, and falls. Currently the ISPSC required handrails at steps on the deck but overlooked the steps into the pool. Falls are more likely on stairs leading into the pool than on the deck as currently the code allows greater riser heights and reduced tread depths on the stairs leading into the pool. This is further compounded by reduced coefficient of friction on the wetted pool stairs and on conditions that are favorable for the growth of biofilms and/or algae on pool stairs.

Requiring one handrail for each 12 ft in width was based on the requirements found in the Model Aquatic Health Code

Bibliography:

2016 Model Aquatic Health Code

<https://www.cdc.gov/mahc/pdf/2016-mahc-code-final.pdf> Page 71, Para 4.5.5

Cost Impact

The code change proposal will increase the cost of construction .

Added a requirement for a handrail. Cost for a handrail in the neighborhood of \$200 and up depending on stair configuration. A handrail is necessary at the stairs to reduce injuries from slips, trips, and falls at the stairs.

Internal ID: 2262

SP47-18

ISPSC: 610.6, 610.6.1, 610.6.2, 610.6.3, 610.6.4

Proponent: John Kelly, Iowa Department of Public Health, representing self

2018 International Swimming Pool and Spa Code

Revise as follows:

610.6 Swimouts. Swimouts shall be located completely outside of the water current or wave action of the pool or spa and can be located in shallow or deep areas of water. pool.

610.6.1 Surface area. An unobstructed surface equal to or greater than that required for the top tread of the pool stairs shall be provided in accordance with Sections 610.5.5 and 610.5.6.

610.6.2 Step required. Where a swimout is used as an entry and exit access point, it shall be provided with ~~a step that meets the pool stair requirements (see Section 610.5).~~ steps and handrails that comply with Section 610.5 and Section 323.2.

610.6.3 Maximum depth. The horizontal surface of a swimout shall be not greater than 20 inches (508 mm) below the waterline.

610.6.4 Color marking. The leading edge of a swimout shall be visually set apart by a stripe having a width of not less than $\frac{3}{4}$ inch (19 mm) and not greater than 2 inches (51 mm). The stripe shall be of a contrasting color to the adjacent surfaces.

Reason:

Clarified and simplified language and coordinated language for swimouts at public pools addressed under Chapter 4 and Chapter 6. Clarified the need for a handrail at the stairs from a swimout.

Cost Impact

The code change proposal will increase the cost of construction .

Added a requirement for a handrail. Cost for a handrail in the neighborhood of \$200 and up depending on stair configuration. A handrail is necessary at the steps from a swimout to reduce injuries from slips, trips, and falls at the stairs.

Internal ID: 2256

SP48-18

ISPSC: 610.7, 610.7.1, 610.7.2, 610.7.3, 610.7.4, 610.7.5, 610.7.6

Proponent: John Kelly, Iowa Department of Public Health, representing self

2018 International Swimming Pool and Spa Code

Revise as follows:

610.7 Underwater seats and benches. Underwater seats and benches shall comply with this section.

610.7.1 Prohibited location. ~~Location.~~ Underwater seats shall not be located in the diving water envelope. benches shall only be located in areas where the pool water depth does not exceed 5 ft (1.5 m).

610.7.2 Surface dimensions. Underwater ~~seats~~ benches shall have an unobstructed surface dimension of not less than ~~10-16 inches (254-406 mm)~~ and not greater than 22 inches (559 mm) in depth measured front to back and not less than ~~24-26 inches (610-660 mm)~~ in width.

610.7.3 Not an entry or exit. Underwater ~~seats and benches~~ shall not be used as an entry or exit for a pool ~~but can be located in shallow or deep areas of water.~~ pool.

610.7.4 Depth. The horizontal surface of ~~seats and benches~~ shall be not greater than 20 inches (508 mm) below the waterline.

610.7.5 Color marking. The leading edge of ~~seats and benches~~ shall be visually set apart by a stripe having a width not less than $\frac{3}{4}$ inch (19 mm) and not greater than 2 inches (51 mm). The stripe shall be of a contrasting color to the adjacent surfaces.

610.7.6 Slip resistant. The top surface of ~~seats and benches~~ shall be slip resistant.

Reason:

This proposal addresses dimensions of underwater seats and benches and their location.

It is not clear where the 10 inch bench surface originated as that would have been too small for patrons. The dimensions were updated based on anthropometric data for men and woman to ensure that dimensions of an underwater bench was large enough for patron use for seating as intended.

The proposal clarified that benches not only couldn't count toward a required point of access but that they shall not be used for entry and exits. While the surface is required to be slip resistant, the step from the bench surface to the deck is too large and there is no handrail so it would be unsafe to step to or from the deck.

Finally, the benches were restricted to a maximum pool depth of 5 feet to be consistent with the requirements of the Model Aquatic Health Code.

From the ANNEX of the 2016 Model Aquatic Health Code:

"4.5.16.3 Maximum Water Depth. The five foot (1.5 m) depth restriction is to address the potential SAFETY issue of stepping or otherwise moving off a bench into deep water. The seat depth below the water line is limited to 20 inches (50.8 cm) maximum so a non-swimmer may be comfortable at that depth but once they move from the bench into a greater water depth it may exceed their comfort and/or skill level."

Bibliography:

Excerpts from: Gordon, Claire C. et. al 1988 Anthropometric Survey of U.S. Personnel: Summary Statistics Interim Report. March 1989.

2016 Model Aquatic Health Code

<https://www.cdc.gov/mahc/pdf/2016-mahc-code-final.pdf>

Cost Impact

The code change proposal will increase the cost of construction .

This proposal increases the size of the benches based on anthropometric data so they better can serve their intended purpose. It also clarifies the marking required for the benches. In both cases there were costs associated with forming the benches and marking the benches so the cost associated with the clarification of the marking of the benches and the depth and width of the benches would be minimal.

Internal ID: 1847

SP49-18

ISpsc: 202, 612 (New), 612.1 (New), 612.2 (New), 612.3 (New), 612.4 (New), 612.4.1 (New), 612.4.2 (New), 612.4.3 (New), 612.4.4 (New), 612.5 (New), 612.5.1 (New), 612.5.2 (New), 612.5.3 (New), 612.5.4 (New), 612.5.5 (New), 612.6 (New), 612.7 (New)

Proponent: Jennifer Hatfield, J. Hatfield & Associates, PL, representing Association of Pool & Spa Professionals (jhatfield@apsp.org)

2018 International Swimming Pool and Spa Code

Add new definition as follows:

INTERACTIVE WATER PLAY FEATURES. Any indoor or outdoor structure designed to allow for public recreational activities with recirculated, filtered, and treated water that includes sprayed, jetted or other water sources contacting bathers and not incorporating standing or captured water as part of the bather activity area. These installations are also known as splash pads, spray pads, and wet decks.

Add new text as follows:

612 INTERACTIVE WATER PLAY FEATURES

612.1 General. Interactive water play features shall comply with Section 612.1 through 612.7.

612.2 Safety hazards. Parts of the interactive water play feature that can be accessed by the users of the feature shall be designed and constructed to not present safety hazards to the users.

612.3 Decking. A deck of not less than 4 feet (1296 mm) in width shall be provided around the perimeter of the interactive water play feature. The deck shall be sloped away from the interactive water play feature.

612.4 Splash pad zone. The splash pad zone shall comply with Section 612.4.1 through 612.4.4.

612.4.1 Surface. Splash pad zone surfaces shall have a slip-resistant and cleanable surface. The manufacturer of manufactured zone surfaces shall certify that such surfacing is suitable for aquatic and chlorinated environments. Direct suction outlets from interactive water play features shall be prohibited.

612.4.2 Slope and water collection. Splash pad zone surfaces shall slope to one or more drain points so that only water from the splash pad zone flows back to a gravity fed collection tank. The slope shall prevent the accumulation or pooling of water and shall not exceed 1/2 inch per foot. Drain openings in the splash pad zone surfaces that can be accessed by users shall not allow a 1/2 inch (12.7 mm) diameter dowel rod to be inserted into the opening. Drain covers in splash pad zone surfaces shall be flat and flush with the zone surface and shall require tools for removal. The manufacturer of such drain covers shall certify that the covers comply with the physical testing and finger-and-limb entrapment requirements in Sections 3 and 6 respectively, of APSP 16.

612.4.3 Nozzles within the interactive water play feature splash pad zone. Nozzles that spray water from the interactive water play feature splash pad zone shall be flush with the zone surface. Openings in such nozzles shall not allow a 1/2 inch (12.7 mm) diameter dowel rod to be inserted into the opening. The water velocity from the orifice of any water nozzle shall not exceed 20 feet (6.1 m) per second.

612.4.4 Other nozzles. Nozzles, other than those on walking surfaces within the interactive water play feature splash pad zone, shall be designed to be clearly visible.

612.5 Water sanitation. The water sanitation shall consist of the equipment covered in Sections 612.5.1 through 612.5.5.

612.5.1 Water collection and treatment tank. Interactive water play features shall drain to a collection and treatment tank. The inside of the tank shall be accessible for cleaning and inspection. The access hatch or lid shall be locked or require a tool to open. The tank capacity shall be not less than 1000 gallons or ten times the number of gallons in a minute when all nozzles are operating simultaneously, whichever is greater. The volume water in the tank, at the design water level, shall not decrease more than 15% of that volume when all pumps and discharge piping fill with water to the discharge points of all nozzles. Tanks shall be provided with a means to empty all water in the tank for the purposes of servicing or cleaning.

612.5.2 Filtration pump. The filtration pump shall be sized to turnover the surge basin capacity in 30 minutes or less. The intake for the pump shall be located to draw water from the lowest elevation in the treatment tank.

612.5.3 Spray nozzle and water feature water disinfection. Spray nozzles and water features shall be supplied by water from the water collection and treatment tank that is equipped with filtration and sanitizing equipment required by Chapter 3 and this Section. Where separate water feature pumps are installed, controls shall prevent those pumps from operation when the filtration pump is not operating.

612.5.4 Disinfection system. In addition to any filtration and sanitizing equipment requirements of Chapter 3 and this Chapter, all water supplied to spray nozzles or other water that can be accessed by a user, shall pass through a secondary disinfection system before discharge to the user. The secondary disinfection system shall be listed and labeled to NSF 50 as having a single-pass, three-log reduction of the cryptosporidium surrogate.

612.5.5 Make-up water system. The water collection and treatment tank shall be provided with a make-up water system that is supplied with potable water.

612.6 Operating instructions. In addition to the documentation and instructions requirements of Chapter 1 and 3, the operating instructions for an interactive water play feature shall require that the circulation system be operated continuously for not less than 4 turnovers prior to operation of the pumps for the spray nozzles and other water features systems.

612.7 Lighting. Where a interactive water play feature will be in operation at night or during periods of inadequate natural lighting, artificial lighting shall be provided in accordance with the same requirements for pool deck area lighting in Section 321.2.2.

Reason:

In previous cycles a similar proposal has been submitted, but committee members had concerns with either the term previously proposed for these type of features or some of the requirements found within the proposal. These highly popular water play areas that are rapidly becoming an alternative to some public swimming pools in many jurisdictions across the country needs to be addressed in the ISPSC in order to provide standards on how they are built in jurisdictions that currently have none and to bring alignment with some state codes that currently have such requirements, as well as requirements in the Model Aquatic Health Code for such features.

In previous code cycles, there was no disagreement that a code language addressing these type of features is needed and we believe based on the input previously provided in past code cycles, this proposal has addressed previous concerns and aligns with industry best practices in the area of interactive water play features (also known as spray pads, splash pads, etc.).

Additional background:

Waterparks have included these attractions in their array of fun things to do for many years. As large waterparks are highly focused on safety and cleanliness of all water used at the park, regulations did not seem to be as necessary for these attractions -- the waterparks knew what to do, how to do it and have an excellent track record. However, as these types of attractions move into the public sector such as at town public parks, many people who are responsible for choosing and operating this equipment might be lacking the waterpark's knowledge about what is critical for a safe installation. Those involved in the pool and spa industry and those involved in operating public pools in jurisdictions across the country are well aware of water contamination occurrence in these type of features.

The ISPSC is the best place to install these requirements within the I-code family of codes as attractions involve circulated and filtered water (similar to what a pool or spa use) for recreational use even though such attractions do not involve users immersing themselves in bodies of water. The California Building Code as well as the Florida Building Code is reflective of many of the proposed concepts and details of the language in this proposal, and these standards exist within the pool and spa sections of their codes.

Bibliography:

Section 5.12.5 of the Model Aquatic Health Code; <https://www.cdc.gov/mahc/editions/current.html>

6th edition (2017) Florida Building Code, Section 454.1

California Building Code: Title 24, Chapter 31B Pool Code

Cost Impact

The code change proposal will increase the cost of construction .

This proposal will increase the cost of construction because additional labor, materials, equipment, and devices are mandated beyond what is currently required by the code. Specifically, the code is currently silent about these types of

attractions which means that any supplier of these attractions could provide any kind of equipment (of safe design or not). In some cases, having these regulations will make the cost of some suppliers' attraction packages be more than if they did not have to comply with these minimum safety requirements. For other suppliers, these requirements are already included in their standard packages.

Internal ID: 1770

2018 GROUP A – PROPOSED CHANGES TO THE INTERNATIONAL FIRE CODE

FIRE CODE COMMITTEE

Dan Weed, CBO, Chair

Rep: City of Victor, CO
Building Official
Colorado Code Consulting, LLC
Denver, CO

Michael E. Whalen, Vice Chair

Construction Official
New Jersey Department of Community Affairs
Codes and Standards
Trenton, NJ

Michael W. Evans

Rep: International Association of Fire Chiefs
Deputy Fire Chief
Brighton Area Fire Authority
Brighton, MI

Sam Francis

National Programs Director
American Wood Council
West Grove, PA

Barry Grieve, CBO

Bldg. Regulatory & Strategy Lead
Target Corporation
Minneapolis, MN

Howard Hopper, FPE

Regulatory Services Program Manager
UL LLC
Fremont, CA

Randall Metz

Rep: Southern California Fire Prevention
Officers Association-ICC Chapter
Fire Marshal
Carlsbad Fire Department
Carlsbad, CA

Derek Murgatroyd, PE

Rep: National Association of State Fire
Marshals
Fire Protection Engineer
Office of the Maryland State Fire Marshal/
Southern Regional Office
Prince Frederick, MD

David R. Owens, CBO, C. I.

Rep: National Association of Home Builders
Managing Member
Owens Inspection Services, LLC
Palmer, AK

Sarah A. Rice, CBO

Project Manager/Partner
The Preview Group Inc.
Cincinnati, OH

Greg Rogers, FMD

Rep: International Association of Fire Chiefs
Fire Marshal
Division Chief/Fire Marshal
Spokane Valley Fire Department
Spokane Valley, WA

Stephen Rondinelli, AIA

Rondinelli Life Safety
Lakewood, CO

Heather Roth, PE

Rep: National Association of State Fire
Marshals
Fire Protection Engineer 2
NYS Office of Fire Prevention and Control
Rochester, NY

Marc Sampson

Assistant Fire Marshal
Longmont Fire Department
Longmont, CO

Scott Stookey

Engineer A-Hazardous Materials
Austin Fire Department
Austin, TX

Staff Secretariats:

Beth Tubbs, PE, FSFPE

Senior Staff Engineer
Codes and Standards Development
ICC - Boston Field Office
Boston, MA

Keith Enstrom, PE
Staff Engineer
International Code Council
Central Regional Office
Country Club Hills, IL

TENTATIVE ORDER OF DISCUSSION 2018 PROPOSED CHANGES TO THE INTERNATIONAL FIRE CODE

The following is the tentative order in which the proposed changes to the code will be discussed at the public hearings. Proposed changes which impact the same subject have been grouped to permit consideration in consecutive changes.

Proposed change numbers that are indented are those which are being heard out of numerical order. Indentation does not necessarily indicate that one change is related to another. Proposed changes may be grouped for purposes of discussion at the hearing at the discretion of the chair. Note that some F code change proposals may not be included on this list, as they are being heard by another committee.

Numbers Not Used

F255-18

F257-18

WUIC

WUIC1-18	F22-18	F53-18	F84-18
WUIC2-18	F23-18	F54-18	F85-18
WUIC3-18	PM8-18 Part II	F55-18	F86-18
WUIC4-18	F24-18	F56-18	F87-18
WUIC5-18	F25-18	G91-18	F88-18
WUIC6-18	F26-18	F57-18	F89-18
WUIC7-18	F27-18	F58-18	F90-18
WUIC8-18	F28-18	F59-18	F91-18
WUIC9-18	F29-18	F60-18	G71-18 Part II
WUIC10-18	F30-18	F61-18	F21-18
WUIC11-18	F31-18	F62-18	F92-18 Part I
WUIC12-18	F32-18	F63-18	F93-18
WUIC13-18	F33-18	F64-18	F94-18
WUIC14-18	F34-18	F65-18	F95-18
WUIC15-18	F35-18	F66-18	F96-18
WUIC16-18	F36-18	F67-18	G67-18

IFC

F1-18	F37-18	S22-18	F97-18
F8-18	F38-18	F68-18	F4-18 Part I
F9-18	F39-18	F69-18	F98-18
F10-18	F40-18	F70-18	F99-18
F6-18	F41-18	F71-18	F100-18
F11-18	F42-18	F72-18	F101-18
F12-18	F43-18	F73-18	F102-18
F13-18	F44-18	F74-18	F103-18
F14-18 Part I	F2-18	F75-18	F104-18
F15-18	F45-18	F76-18	F105-18
F16-18	F46-18	F77-18	F106-18
F17-18	F47-18	F78-18	F107-18
F18-18	F48-18	F79-18 Part I	F108-18
F19-18	F49-18	F80-18	F109-18
F20-18	F50-18	F81-18	F110-18
	F51-18	F82-18	F111-18
	F52-18	F83-18 Part I	F112-18

F113-18	F168-18	F215-18	F267-18 Part I
F114-18	F169-18	F216-18	F271-18
F115-18	F170-18	F217-18	F272-18
F116-18	F171-18	F218-18	F273-18
F117-18	F172-18	F219-18	F274-18
F118-18	F173-18	F220-18	F275-18
F119-18	F174-18	F221-18	F276-18
F120-18	G28-18	F222-18	F277-18
F121-18	F175-18	F223-18	G50-18
F122-18 Part I	F176-18	F224-18	F278-18
F123-18	G23-18 Part II	F225-18	F279-18
F124-18	F177-18	F226-18	F280-18
F125-18	F178-18	F227-18	F281-18
F126-18	F179-18	F228-18	F282-18
F127-18	F180-18	F229-18	F283-18
F128-18	F181-18	F230-18	F284-18
F129-18	F182-18	F231-18	F285-18
F130-18	F183-18	G52-18	F286-18
F131-18	F184-18	F232-18	F287-18
F132-18	F186-18	F233-18	F288-18
F133-18	F187-18	F234-18	F289-18
F134-18	F188-18	F235-18	F290-18
F135-18	F189-18	F236-18	F291-18
F136-18	F190-18	F237-18	F292-18
F138-18	F191-18	F238-18	F293-18
F139-18	F192-18	F239-18	F294-18
F140-18	F193-18	F240-18	F295-18
F185-18	F194-18	F241-18	F296-18
F141-18	F195-18	F242-18	F297-18 Part I
F142-18	F196-18	F243-18	F297-18 Part II
F143-18	F197-18	F244-18	F298-18
F144-18	F198-18	F7-18	F299-18
F145-18	F199-18	F245-18	F300-18
F146-18	F200-18	F246-18	F301-18
F147-18	F201-18	F247-18	F302-18
F148-18	F202-18	F248-18	F303-18
F149-18	F203-18	F249-18	F304-18
F150-18	G92-18	F5-18	G49-18
F151-18	F204-18	F250-18	G51-18
F152-18	F205-18	F251-18	F305-18
F153-18	F206-18	F252-18	F306-18
F154-18	F207-18	F253-18	F307-18
F155-18	F137-18	F254-18	F308-18
F156-18	F208-18	F256-18	F309-18
F157-18	F209-18	F258-18	F310-18
F158-18	F210-18	F259-18	F311-18
F159-18	F3-18	F260-18	F312-18
G26-18	F211-18	F261-18	F313-18
F160-18	G69-18	F262-18 Part I	F314-18
F161-18	G70-18	F263-18	F315-18
F162-18	F212-18	F264-18	F316-18
F163-18	F213-18	F265-18	F317-18
F164-18	G19-18	F266-18	F318-18
F165-18	G20-18	F268-18	F319-18
F166-18	F214-18	F269-18	F320-18
F167-18	FG22-18	F270-18	F321-18

F322-18
F323-18
F324-18
F325-18
F326-18
F327-18
F328-18

WUIC1-18

IWUC: 202 (New)

Proponent: Marcelo Hirschler, representing GBH International (gbhint@aol.com)

2018 International Wildland-Urban Interface Code

Add new definition as follows:

ROOF ASSEMBLY. A system designed to provide weather protection and resistance to design loads. The system consists of a roof covering and roof deck or a single component serving as both the roof covering and the roof deck. A roof assembly includes the roof deck, underlayment and roof covering, and can also include a thermal barrier, ignition barrier, insulation or a vapor retarder.

ROOF COVERING. The covering applied to the roof deck for weather resistance, fire classification or appearance.

ROOF COVERING SYSTEM. See "Roof assembly".

ROOF DECK. The flat or sloped surface not including its supporting members or vertical supports.

Reason:

This proposal adds four definitions into chapter 2 of the IWUC.

The terms "roof covering", "roof assembly" and "roof decking" and "roof deck" are used in the code but are not defined. It appears that the terms "roof decking" and "roof deck" are used interchangeably. The term "roof covering" is used in instances (for example when dealing with fire performance) where it actually means the roof assembly (or roof covering system). This proposal takes the definitions from the IRC and incorporates them into Chapter 2 of the IWUC. Separate proposals recommend terminology changes in the code for consistency.

For information, the IRC and IBC definitions follow:

IRC:

[RB] ROOF ASSEMBLY. A system designed to provide weather protection and resistance to design loads. The system consists of a roof covering and roof deck or a single component serving as both the roof covering and the roof deck. A roof assembly includes the roof deck, underlayment and roof covering, and can also include a thermal barrier, ignition barrier, insulation or a vapor retarder. For the definition applicable in Chapter 11, see Section N1101.6.

[RB] ROOF COATING. A fluid-applied, adhered coating used for roof maintenance or roof repair, or as a component of a roof covering system or roof assembly.

[RB] ROOF COVERING. The covering applied to the roof deck for weather resistance, fire classification or appearance.

[RB] ROOF COVERING SYSTEM. See "Roof assembly."

[RB] ROOF DECK. The flat or sloped surface not including its supporting members or vertical supports.

IBC:

[BS] ROOF ASSEMBLY (For application to Chapter 15 only). A system designed to provide weather protection and resistance to design loads. The system consists of a roof covering and roof deck or a single component serving as both the roof covering and the roof deck. A roof assembly can include an underlayment, a thermal barrier, insulation or a vapor retarder.

[BS] ROOF COATING. A fluid-applied, adhered coating used for roof maintenance or roof repair, or as a component of a roof covering system or roof assembly.

[BS] ROOF COVERING. The covering applied to the roof deck for weather resistance, fire classification or appearance.

ROOF COVERING SYSTEM. See "Roof assembly".

[BS] ROOF DECK. The flat or sloped surface constructed on top of the exterior walls of a building or other supports for the purpose of enclosing the story below, or sheltering an area, to protect it from the elements, not including its supporting members or vertical supports.

Cost Impact

The code change proposal will not increase or decrease the cost of construction .

This code change just adds definitions for clarity.

Internal ID: 774

WUIC2-18

IWUIC: 504.2, 505.2, 506.2

Proponent: Marcelo Hirschler, GBH International, representing GBH International (gbhint@aol.com)

2018 International Wildland-Urban Interface Code

Revise as follows:

504.2 Roof ~~covering-assembly~~. Roofs shall have a roof assembly that complies with a Class A rating when tested in accordance with ASTM ~~E-108-E108~~ or UL 790. For roof ~~coverings-assemblies~~ where the profile allows a space between the roof covering and roof ~~decking-deck~~, the space at the eave ends shall be firestopped to preclude entry of flames or embers, or have one layer of 72-pound (32.4 kg) mineral-surfaced, nonperforated cap sheet complying with ASTM ~~D-3909-D3909~~ installed over the combustible ~~decking-roof deck~~.

Exceptions:

1. Class A roof assemblies include those with coverings of brick, masonry or an exposed concrete roof deck.
2. Class A roof assemblies also include ferrous or copper shingles or sheets, metal sheets and shingles, clay or concrete roof tile or slate installed on noncombustible decks or ferrous, copper or metal sheets installed without a roof deck on noncombustible framing.
3. Class A roof assemblies include minimum 16 oz/sq. ft. (0.0416 kg/m²) copper sheets installed over combustible roof decks.

505.2 Roof ~~covering-assembly~~. Roofs shall have a roof assembly that complies with not less than a Class B rating when tested in accordance with ASTM E108 or UL 790, or an *approved noncombustible roof covering*. For roof ~~coverings-assemblies~~ where the profile allows a space between the roof covering and roof ~~decking-deck~~, the space at the eave ends shall be firestopped to preclude entry of flames or embers, or have one layer of 72- pound (32.4 kg) mineral-surfaced, nonperforated cap sheet complying with ASTM D3909 installed over the combustible ~~decking-roof deck~~.

506.2 Roof ~~covering-assembly~~. Roofs shall have a roof assembly that complies with not less than a Class C rating when tested in accordance with ASTM E108 or UL 790 or an *approved noncombustible roof covering*. For roof ~~coverings-assemblies~~ where the profile allows a space between the roof covering and roof ~~decking-deck~~, the space at the eave ends shall be firestopped to preclude entry of flames or embers, or have one layer of 72- pound (32.4 kg) mineral-surfaced, nonperforated cap sheet complying with ASTM D3909 installed over the combustible ~~decking-roof deck~~.

Reason:

The terms “roof covering”, “roof assembly” and “roof decking” and “roof deck” are used in the code but are not defined. It appears that the terms “roof decking” and “roof deck” are used interchangeably. The term “roof covering” is used in instances (for example when dealing with fire performance) where it actually means the roof assembly (or roof covering system). A separate proposal takes the definitions from the IRC and incorporates them into Chapter 2 of the IWUIC. This proposal recommend terminology changes in the code for consistency.

This proposal simply cleans up terminology in the roofing section (504.2, 505.2 and 506.2) and does it consistently with the definitions of the terms in the IRC. It is associated with a parallel proposal that adds the IRC definitions into the IWUIC.

Cost Impact

The code change proposal will not increase or decrease the cost of construction .

This proposal simply clarifies terms as defined in the IRC (and as proposed for definition in the IWUIC).

Internal ID: 778

WUIC3-18

IWUIC: 503.2

Proponent: Marcelo Hirschler, GBH International, representing GBH International (gbhint@aol.com)

2018 International Wildland-Urban Interface Code

Revise as follows:

503.2 Ignition-resistant building material. Ignition-resistant building materials shall comply with any one of the following:

1. Material shall be tested on ~~all sides the front and back faces either with the extended~~ ASTM E84 (UL 723) test ~~or ASTM E 2768, except panel products shall be permitted to test only the front and back faces. Panel products shall be tested with a ripped or cut longitudinal gap of $\frac{1}{8}$ inch (3.2 mm). Materials that, when tested in accordance with the test procedures set forth in ASTM E84 or UL 723, extended~~ for a test period of 30 minutes, or with ASTM E ~~2768~~E2768, and shall comply with the following:
 - 1.1. Flame spread. Material shall exhibit a flame spread index not exceeding ~~25 and shall not show evidence of progressive combustion following the extended 30-minute test.~~25.
 - 1.2. Flame front. Material shall exhibit a flame front that does not progress more than $10\frac{1}{2}$ feet (3200 mm) beyond the centerline of the burner at any time during the extended 30-minute test. This shall be considered evidence of no significant progressive combustion.
 - 1.3. Weathering. Ignition-resistant building materials shall maintain their performance in accordance with this section under conditions of use. Materials shall meet the performance requirements for weathering (including exposure to temperature, moisture and ultraviolet radiation) contained in the following standards, as applicable to the materials and the conditions of use:
 - 1.3.1. Method A "Test Method for Accelerated Weathering of Fire-Retardant-Treated Wood for Fire Testing" in ASTM D 2898, for fire-retardant-treated wood, wood-plastic composite and plastic lumber materials.
 - 1.3.2. ASTM D 7032 for wood-plastic composite materials.
 - 1.3.3. ASTM D 6662 for plastic lumber materials.
 - 1.4. Identification. Materials shall bear identification showing the fire test results.
Exception: ~~Materials composed of a combustible core and a noncombustible exterior covering made from either aluminum at a minimum 0.019 inch (0.48 mm) thickness or corrosion-resistant steel at a minimum 0.0149 inch (0.38 mm) thickness shall not be required to be tested with a ripped or cut longitudinal gap.~~
2. Noncombustible material. Material that complies with the requirements for *noncombustible* materials in Section 202.
3. Fire-retardant-treated wood. Fire-retardant-treated wood identified for exterior use and meeting the requirements of Section 2303.2 of the International Building Code.
4. Fire-retardant-treated wood roof coverings. Roof assemblies containing fire-retardant-treated wood shingles and shakes that comply with the requirements of Section 1505.6 of the International Building Code and classified as Class A roof assemblies as required in Section 1505.2 of the International Building Code.

Reason:

This proposal makes 4 changes, discussed below:

First:

It makes no sense to test "all sides" of a product when it becomes physically impossible to distinguish between the ends and no ASTM E84 specimen (which is 24 feet long by 2 feet wide) can be obtained from the ends. When a specimen is presented for testing, if all sides look the same, a lab can't tell which is a second side. Testing front and back is feasible but other sides are not (because the maximum ASTM E84 thickness is 4 inches). In order to test a "2 by 4" specimen a simple calculation is that you would have to cut it into 864 pieces that are 2 x 4, and 4 inches thick, and somehow fasten them together: that is obviously ridiculous. It makes perfect sense to test the front and the back

sides to ensure that the same fire performance is present on each side and that requirement is proposed to be retained.

Second:

The requirement to test with a rip or gap is not contained in either ASTM E84 or ASTM E2768 and is simply supposed to differentiate between fire retardant treated wood materials and coated materials. However, there is evidence that impregnation with fire retardant (as for fire retardant treated wood or FRTW) is not a guarantee that the additive penetrates uniformly throughout the wood and yet FRTW is not required to be tested on more than one side or with a gap or rip. That makes no sense. In fact, also, some coated products will be able to meet the requirements with the gap or rip so nothing is gained by adding that requirement. If there is concern about the implications of using coated wood products exceptions can (and should) be placed where the use of coated products is inappropriate, especially as decking materials.

Third:

ASTM E2768 was developed by ASTM E05 (committee on fire standards) specifically for the purpose of giving instructions on how to conduct ASTM E84 when extended to 30 minutes. In fact ASTM E84 states that materials required to be tested to meet the extended ASTM E84 to a 30-minute duration are covered by ASTM E2768. No other standard or code requirement explains how to test for "significant progressive combustion".

ASTM E2768 contains a section that explains how to assess the pass/fail criteria and it states as follows under "conditions of classification":

13.1 The test method has the following conditions of classification for a material or product to be classified as meeting the requirements of this standard:

13.1.1 The flame spread index shall be 25 or less as determined for the initial 10 min test period,

13.1.2 The flame front shall not progress more than 10.5 ft (3.2 m) beyond the centerline of the burners at any time during the 30 min test period. This is considered evidence of no significant progressive combustion in this test method.

13.2 For materials or products that are not homogeneous or symmetrical about their longitudinal axis, only surfaces that have been individually tested shall be eligible to be classified and reported as meeting the conditions of classification of this standard.

Consequently, the changes proposed to items 1.1 and 1.2 are consistent with the statements in ASTM E84 and ASTM E2768.

Fourth:

The exception is proposed to be eliminated because it is unnecessary if the requirement to test with a rip or gap is deleted.

A report on ASTM E2768 tests conducted by a fire test lab (QAI) is attached and it shows that when the flame front does not progress more than 10.5 ft beyond the centerline of the burners this is considered evidence of no significant progressive combustion. Also, no rip or gap used, because that is not what is required by ASTM E2768. Two pages of a similar report (title page and page 7) from another fire test lab (Intertek) also shows that the same criterion is used for both issues.

Cost Impact

The code change proposal will decrease the cost of construction .

This will eliminate unnecessary testing that represents a barrier without adding fire safety.

Internal ID: 851

WUIC4-18

IWUIC: 503.2

Proponent: Thomas Meyers, Building Intuition, LLC, representing Self (codeconsultant@gmail.com)

2018 International Wildland-Urban Interface Code

Revise as follows:

503.2 Ignition-resistant building material. Ignition-resistant building materials shall comply with any one of the following:

1. Material shall be tested on all sides with the extended ASTM E84 (UL 723) test or ASTM E 2768, except panel products shall be permitted to test only the front and back faces. Panel products shall be tested with a ripped or cut longitudinal gap of $\frac{1}{8}$ inch (3.2 mm). Materials that, when tested in accordance with the test procedures set forth in ASTM E84 or UL 723 for a test period of 30 minutes, or with ASTM E 2768, comply with the following:
 - 1.1. Flame spread. Material shall exhibit a flame spread index not exceeding 25 and shall not show evidence of progressive combustion following the extended 30-minute test.
 - 1.2. Flame front. Material shall exhibit a flame front that does not progress more than $10\frac{1}{2}$ feet (3200 mm) beyond the centerline of the burner at any time during the extended 30-minute test.
 - 1.3. Weathering. Ignition-resistant building materials shall maintain their performance in accordance with this section under conditions of use. Materials shall meet the performance requirements for weathering (including exposure to temperature, moisture and ultraviolet radiation) contained in the following standards, as applicable to the materials and the conditions of use:
 - 1.3.1. Method A "~~Test-~~Test Method for Accelerated Weathering of Fire-Retardant-Treated Wood for Fire ~~Testing~~-Testing" in ASTM D 2898, for fire-retardant-treated wood, wood-plastic composite and plastic lumber materials.
 - 1.3.2. ASTM D 7032 for wood-plastic composite materials.
 - 1.3.3. ASTM D 6662 for plastic lumber materials.
 - 1.4. Identification. Materials shall bear identification showing the fire test results.

~~**Exception:** Materials composed of a combustible core and a noncombustible exterior covering made from either aluminum at a minimum 0.019 inch (0.48 mm) thickness or corrosion resistant steel at a minimum 0.0149 inch (0.38 mm) thickness shall not be required to be tested with a ripped or cut longitudinal gap.~~

2. Noncombustible material. Material that complies with the requirements for *noncombustible* materials in Section 202.
3. Fire-retardant-treated wood. Fire-retardant-treated wood identified for exterior use and meeting the requirements of Section 2303.2 of the International Building Code.
4. Fire-retardant-treated wood roof coverings. Roof assemblies containing fire-retardant-treated wood shingles and shakes that comply with the requirements of Section 1505.6 of the International Building Code and classified as Class A roof assemblies as required in Section 1505.2 of the International Building Code.

Reason:

Recent cladding fires involving metal composite materials (MCM's), such as the Grenfell Tower in London, raises questions about the validity of allowing materials to be evaluated contrary to actual end use conditions. MCM's are frequently installed with exposed cores at joints, intersections, and corners. The effect of the exposed core on potential ignition and fire spread should be part of the testing evaluation as it realistically represents actual construction practices.

Cost Impact

The code change proposal will not increase or decrease the cost of construction .

No cost change anticipated for existing, compliant products. Additional costs applied to certain products requiring retesting may occur at manufacturer discretion.

Internal ID: 2068

WUIC5-18

IWUIC: 503.2

Proponent: Tim Earl, GBH International, representing self (tearl@gbhinternational.com)

2018 International Wildland-Urban Interface Code

Revise as follows:

503.2 Ignition-resistant building material. Ignition-resistant building materials shall comply with any one of the following:

1. Material shall be tested on ~~all sides~~ the front and back faces either with the extended ASTM E84 (UL 723) test, extended for a test period of 30 minutes, or ASTM E 2768, except panel products shall be permitted to test only the front and back faces, with ASTM E2768. Panel products shall be tested with a ripped or cut longitudinal gap of $\frac{1}{8}$ inch (3.2 mm). ~~Materials that, when tested in accordance with the test procedures set forth in ASTM E84 or UL 723 for a test period of 30 minutes, or with ASTM E 2768, shall comply with the following:~~
 - 1.1. Flame spread. Material shall exhibit a flame spread index not exceeding ~~25 and shall not show evidence of progressive combustion following the extended 30-minute test.~~ 25.
 - 1.2. Flame front. Material shall exhibit a flame front that does not progress more than $10\frac{1}{2}$ feet (3200 mm) beyond the centerline of the burner at any time during the extended 30-minute test. This shall be considered evidence of no significant progressive combustion.
 - 1.3. Weathering. Ignition-resistant building materials shall maintain their performance in accordance with this section under conditions of use. Materials shall meet the performance requirements for weathering (including exposure to temperature, moisture and ultraviolet radiation) contained in the following standards, as applicable to the materials and the conditions of use:
 - 1.3.1. Method A "Test Method for Accelerated Weathering of Fire-Retardant-Treated Wood for Fire Testing" in ASTM D 2898, for fire-retardant-treated wood, wood-plastic composite and plastic lumber materials.
 - 1.3.2. ASTM D 7032 for wood-plastic composite materials.
 - 1.3.3. ASTM D 6662 for plastic lumber materials.
 - 1.4. Identification. Materials shall bear identification showing the fire test results.

Exception: Materials composed of a combustible core and a noncombustible exterior covering made from either aluminum at a minimum 0.019 inch (0.48 mm) thickness or corrosion-resistant steel at a minimum 0.0149 inch (0.38 mm) thickness shall not be required to be tested with a ripped or cut longitudinal gap.
2. Noncombustible material. Material that complies with the requirements for *noncombustible* materials in Section 202.
3. Fire-retardant-treated wood. Fire-retardant-treated wood identified for exterior use and meeting the requirements of Section 2303.2 of the International Building Code.
4. Fire-retardant-treated wood roof coverings. Roof assemblies containing fire-retardant-treated wood shingles and shakes that comply with the requirements of Section 1505.6 of the International Building Code and classified as Class A roof assemblies as required in Section 1505.2 of the International Building Code.

Reason:

It makes no sense to test "all sides" of a product when it becomes physically impossible to distinguish between the ends and no ASTM E84 specimen (which is 24 feet long by 2 feet wide) can be obtained from the ends. When a specimen is presented for testing, if all sides look the same, a lab can't tell which is a second side. Testing front and back is feasible but other sides are not (because the maximum ASTM E84 thickness is 4 inches). In order to test a "2 by 4" specimen a simple calculation is that you would have to cut it into 864 pieces that are 2 x 4, and 4 inches thick, and somehow fasten them together: that is obviously ridiculous. It makes perfect sense to test the front and the back sides to ensure that the same fire performance is present on each side and that requirement is proposed to be retained.

ASTM E2768 was developed by ASTM E05 (committee on fire standards) specifically for the purpose of giving instructions on how to conduct ASTM E84 when extended to 30 minutes. In fact ASTM E84 states that materials required to be tested to meet the extended ASTM E84 to a 30-minute duration are covered by ASTM E2768. ASTM E2768 contains a section that explains how to assess the pass/fail criteria and it states as follows under "conditions of classification":

13.1 The test method has the following conditions of classification for a material or product to be classified as meeting the requirements of this standard:

13.1.1 The flame spread index shall be 25 or less as determined for the initial 10min test period,

13.1.2 The flame front shall not progress more than 10.5 ft (3.2 m) beyond the centerline of the burners at any time during the 30 min test period. This is considered evidence of no significant progressive combustion in this test method.

13.2 For materials or products that are not homogeneous or symmetrical about their longitudinal axis, only surfaces that have been individually tested shall be eligible to be classified and reported as meeting the conditions of classification of this standard.

Consequently, the changes proposed to items 1.1 and 1.2 are consistent with the statements in ASTM E84 and ASTM E2768.

No other standard contains information on how to assess "no significant progressive combustion".

Cost Impact

The code change proposal will decrease the cost of construction .

This will reduce the amount of testing required by eliminating unnecessary tests on all sides of homogeneous wood specimens.

Internal ID: 1046

WUIC6-18

IWUIC: 504.5, 504.5.1 (New), 07

Proponent: David Tyree, American Wood Council, representing American Wood Council (dtyree@awc.org)

2018 International Wildland-Urban Interface Code

Delete and substitute as follows:

~~**504.5 Exterior walls.** Exterior walls of buildings or structures shall be constructed with one of the following methods:~~

- ~~1. Materials *approved* for not less than 1-hour fire-resistance-rated construction on the exterior side.~~
- ~~2. *Approved noncombustible* materials.~~
- ~~3. Heavy timber or log wall construction.~~
- ~~4. Fire-retardant treated wood on the exterior side. The fire-retardant treated wood shall be labeled for exterior use and meet the requirements of Section 2303.2 of the International Building Code.~~
- ~~5. Ignition-resistant materials complying with Section 503.2 on the exterior side.~~

~~Such material shall extend from the top of the foundation to the underside of the roof sheathing.~~

~~**504.5 Exterior walls.** Exterior walls of buildings or structures shall be tested in accordance with ASTM E2707 with the conditions of acceptance in Section 504.5.1.~~

~~**Exception:** Any of the following shall be deemed to meet the assembly performance requirement of this section.~~

- ~~1. One layer of 5/8" gypsum sheathing applied behind the exterior wall covering or cladding on the exterior side of the framing;~~
- ~~2. Materials approved for not less than 1-hour fire-resistance-rated construction on the exterior side of the wall assembly when tested in accordance with ASTM E119.~~

~~Exterior wall coverings shall have a class B flame spread index and shall extend from the top of the foundation to the underside of the roof sheathing.~~

Add new text as follows:

~~**504.5.1 Conditions of Acceptance when tested in accordance with ASTM E2707.** The test shall be conducted in accordance with ASTM E2707 and the conditions of acceptance in items 1 and 2 below shall be met.~~

- ~~1. Absence of flame penetration through the wall assembly at any time.~~
- ~~2. Absence of glowing combustion on the unexposed side of the assembly at any time during the 70-min test.~~

Add new standard(s) follows:

ASTM

ASTM International
100 Barr Harbor Drive, P.O. Box
C700
West Conshohocken PA 19428-
2959

E2707-15:

~~**Standard Test Method for Determining Fire Penetration of Exterior Wall Assemblies Using a Direct Flame Impingement Exposure**~~

Reason:

This proposal includes a wall assembly fire performance requirement by adding ASTM consensus standard, ASTM E2707, "Standard Test Method for Determining Fire Penetration of Exterior Wall Assemblies Using a Direct Flame Impingement Exposure" as the ASTM test method for the acceptable fire performance of exterior wall assemblies in WUI areas. Exterior sides of wall assemblies that meet 1-hour fire resistance rating in accordance with ASTM E119 is proposed to be left as currently referenced. All other requirements that are not based on an exterior wall fire performance test are proposed to be deleted. WUI exterior wall fire performance is dependent on the cladding on the wall as well as its method of installation. Requiring the exterior wall systems to be tested in accordance with

ASTM E2707 or ASTM E119 would add the method of installation, including joints, to compliance criteria.

ASTM E2707 test method measures the ability of the wall system to resist fire penetration from the exterior into the wall cavity or unexposed side of the test assembly under the conditions of exposure. This test method was developed in response to recommendations developed by the California Office of the State Fire Marshal (SFM) and the International Wildland-Urban Interface Code (IWUIC) regarding the enhancement of exterior fire protection of structures in a wildland fire (exterior wildfire exposure). This proposal establishes performance criteria for materials to be used on the exterior buildings, structures, and detached accessory structures. While this test method is intended to address one component of an exterior wildfire exposure, that is, exterior walls exposed to direct flame impingement the proposal goes on to regulate the flame spread of the materials applied to the exterior wall. The purpose of this standard is to provide a definitive set of procedures for the evaluation and measurement of the resistance to fire penetration of exterior wall structures. The test is a practical attempt to simulate the case where ignition of flammable materials (plants, trash, a deck or shed, etc.) might be adjacent to a building.

Exterior sides of wall assemblies that meet 1-hour fire resistance rating in accordance with ASTM E119 is proposed to be left as currently referenced. A second option of providing a layer of 5/8" gypsum sheathing is consistent with this requirement but gives a prescriptive solution to requiring the test. All other requirements that are not based on an exterior wall fire test ASSEMBLIES are proposed to be deleted. WUI exterior wall fire performance is dependent on the cladding material as well as its method of installation. Requiring that exterior wall systems be tested in accordance with ASTM E2707 or ASTM E119 would add the method of installation to compliance criteria.

A 10-min 150-kW exposure was used for the siding-sheathing combinations, followed by an additional 60- min observation to detect any smoldering combustion. The use of infrared photography of the back of the test wall was used to reveal development of increasing temperatures or persisting hot spots. Other tests were run on solely cladding or sheathing, where the burner was left on until failure to determine the weak points in various materials. Most of the siding-sheathing assemblies exhibited acceptable performance. However, the hardboard siding failed because it burned and warped away from the sheathing, exposing it to flames. For the siding-only tests flame penetration occurred at joints for "combustible" siding. The nature of the siding joints had a substantial effect on relative performance. Most vulnerable was the plain bevel, while rabbeted and shiplap joints were increasingly resistant to flame-through. Tests on different types of siding materials including but not limited to; combustible, heavy timber, fire retardant treated wood and ignition resistant materials should also require testing in accordance with this standard since they were grandfathered in with the exceptions and have never been tested in our knowledge. It is thought that the type of joints using these construction materials will also have a questionable response depending of construction procedure and should also be tested to gain acceptance.

Additionally, it is recognized that the flame spread of the wall material is also very important to the wall performance in Wildland Urban Interface events. With this proposal BOTH the fire penetration through the exterior wall covering assembly into the wall cavity, and surface flame spread of wall covering material are taken into consideration. The current requirement pertains to exterior wall covering material without consideration of the exterior wall assembly performance. Qualifying just the wall covering material may not necessarily assure the safety from a wildland fire exposure. It has been shown that joints are a real weakness in the WUI envelope protection and this proposal addresses that concern. The exception to have an exterior wall assembly tested in accordance with ASTM E2707 is to allow assemblies approved for not less than 1-hour fire-resistance construction applied to the exterior side of the wall assembly or provide a layer of gypsum board as a part of the exterior wall covering assembly.

It is also reasonable to assume that accelerated aging/weathering tests will be required by an AHJ or listing agency as it is important to evaluate the permanence of the fire retardant properties of the product. The aging process will be defined by the intended end-use application and the materials content of the product being tested. Since the proposed test method is applicable to a wide range of products or assemblies, it is not reasonable to assume that all materials should be subjected to the same accelerated aging/weathering process. Test Method ASTM D2898 has long been used as an accelerated weathering process with fire retardant treated lumber products where leaching of chemicals may be an issue. For a product comprised of 100 % plastic, where leaching may not be an issue, some other test method may be appropriate. There are several different accelerated aging/ weathering procedures available. The effectiveness of these procedures vary with changes in the composition of the materials being aged. The language within the standard is worded so that accelerated aging/weathering is not required in all cases, but is required where such results are a condition of acceptance for a product to be used in a code regulated application. As such, the language provides the flexibility needed for the range of materials being used for exterior wall applications.

Cost Impact

The code change proposal will not increase or decrease the cost of construction .

This proposal adds an ASTM standard which allows wall assemblies to be tested and approved for WUI exterior wall construction.

Analysis: A review of the standard proposed for inclusion in the code, ASTM E2707-15 Standard Test Method for

Determining Fire Penetration of Exterior Wall Assemblies Using a Direct Flame Impingement Exposure, with regard to the ICC criteria for referenced standards (Section 3.6 of CP#28) will be posted on the ICC website on or before April 2, 2018.

Internal ID: 1054

WUIC7-18

IWUIC: 504.7

Proponent: Marcelo Hirschler, GBH International, representing GBH International (gbhint@aol.com)

2018 International Wildland-Urban Interface Code

Revise as follows:

504.7 Appendages and projections. *Unenclosed accessory structures* attached to buildings with habitable spaces and projections, such as decks, shall be not less than 1-hour fire- resistance-rated construction, heavy timber construction or constructed of one of the following:

1. *Approved noncombustible* materials.
2. Fire-retardant-treated wood identified for exterior use and meeting the requirements of Section 2303.2 of the International Building Code.
3. Ignition-resistant building materials in accordance with Section 503.2.

Exception: Coated materials shall not be used as the walking surface of decks.

Reason:

It is possible to create ignition-resistant materials that are the result of coating the front and back of certain panels (such as wood panels) and that meet the requirements. Such materials are typically fully suitable for use in most applications where ignition resistant materials are called for except for walking surfaces because of the probability of erosion after a certain period of use.

Therefore, if the coating is being eroded, the fire safety will decrease.

Cost Impact

The code change proposal will increase the cost of construction .

It is unlikely that coated materials are being used for decking but if they are used, this proposal will eliminate an option.

Internal ID: 853

WUIC8-18

IWUIC: 504.7, 504.7.1 (New), 504.7.1.1 (New), 07

Proponent: David Tyree, American Wood Council, representing American Wood Council (dtyree@awc.org)

2018 International Wildland-Urban Interface Code

Revise as follows:

504.7 Appendages and projections. *Unenclosed accessory structures* attached to buildings with habitable spaces and projections, such as decks, shall have walking surfaces complying with Section 504.7.1 or shall be not less than 1-hour fire- resistance-rated construction, heavy timber construction or constructed of one of the following:

1. *Approved noncombustible* materials.
2. Fire-retardant-treated wood identified for exterior use and meeting the requirements of Section 2303.2 of the International Building Code.
3. Ignition-resistant building materials in accordance with Section 503.2.

Add new text as follows:

504.7.1 Deck Materials. The walking surface material of decks, porches, balconies and stairs shall comply with Section 504.7 or shall be tested in accordance with ASTM E2632 and shall meet the conditions of acceptance in Section 504.7.1.1. If abutting an exterior wall that otherwise complies with this chapter, the portion of the exterior wall covering material abutting the walking surface shall have a Class A flame spread index when tested in accordance with ASTM E84 or UL 723 and shall extend to a minimum height of 24 inches above the walking surface and a minimum of 12 inches below the walking surface.

504.7.1.1 Conditions of acceptance when tested in accordance with ASTM E2632. The test shall be conducted in triplicate and the peak heat release rate of each test shall be less than or equal to 25 kW per square foot of deck area (269 kW per square meter of deck area).

Add new standard(s) follows:

ASTM

ASTM International
100 Barr Harbor Drive, P.O. Box
C700
West Conshohocken PA 19428-
2959

E2632/E2632M-13e1:

Standard Test Method for Evaluating the Under-Deck Fire Test Response of Deck Materials

Reason:

This proposal includes a fire performance requirement by adding a ANSI Consensus Standard specifically developed to qualify exterior decks for Wildland-Urban Interface fire performance. ASTM E2632, "Standard Test Method for Evaluating the Under-Deck Fire Test Response of Deck Materials". This test method was developed in response to recommendations developed by the California Office of the State Fire Marshal (OSFM) regarding the performance of decking materials in a wildland fire (exterior wildfire exposure). The ASTM E2632 test method addresses the case where a brand is blown or a surface fire extends under a deck and onto combustible material causing flaming combustion that may lead to penetration through the siding or some other vulnerable point of the main structure. The test is a practical attempt to simulate the case where combustible material resides beneath a structure and can become involved in a wildland fire event.

The major concern about the ignition of decking is the hazard that it presents to the habitable structure. Decking is usually configured so that it is capable of being threatened by two potential sources of ignition: brands on the surface of the decking and flaming material underneath the structure. It has been shown that in a typical Wildland-Urban Interface fire, burning brands can land on a deck causing combustion leading to flaming combustion. The flames impinge on the wall of the structure causing penetration at a vulnerable point into the structure. This proposal not only requires the decking material to be limited to a peak heat release rate of 25kw per square foot but adds additional requirements to provide non-combustible and ignition resistant construction to a height of 24 inches above the deck and 12 inches below the deck to protect the structure from any flaming caused by a burning brand landing on an

exterior deck surface. The additional requirement requiring a Class A covering material to a height of 24 inches above the walking surface and 12 inches below, have been added to specifically address recent testing conducted to examine potential vulnerabilities of wood decks to continuous, wind-driven firebrand showers. ASTM E2632 test method provides for several conditions that must be met to pass the performance criteria including: a limited heat release rate (HHR); absence of sustained flaming or glowing combustion; and absence of structural failure of the deck board. Smaller values of heat release rate reflect lower combustibility than larger values. This proposal uses the same acceptance criteria as the State of California SFM office which specifies a maximum net peak heat release of (no more than) 25 kW/ft² [269 kW/m²] for deck boards. For comparison, the HHR for a large juniper bush can be as high as 1000 kW.

Cost Impact

The code change proposal will not increase or decrease the cost of construction .

This proposal allows different materials to be testing to comply with the WUI decking standards and will not increase the cost of construction over current required methods of construction.

Analysis: A review of the standard proposed for inclusion in the code, ASTM E2632 Standard Test Method for Evaluating the Under-Deck Fire Response of Deck Materials, with regard to the ICC criteria for referenced standards (Section 3.6 of CP#28) will be posted on the ICC website on or before April 2, 2018.

Internal ID: 1064

WUIC9-18

IWUIC: 504.7, 504.7.1 (New), 507.1.1 (New), 07

Proponent: Kuma Sumathipala, American Wood Council, representing American Wood Council
(ksumathipala@awc.org)

2018 International Wildland-Urban Interface Code

Revise as follows:

504.7 Appendages and projections. *Unenclosed accessory structures* attached to buildings with habitable spaces, projections and projections, such as decks, other than walking surfaces of decks, shall be not less than 1-hour fire-resistance-rated construction, heavy timber construction or constructed of one of the following:

1. *Approved noncombustible materials.*
2. Fire-retardant-treated wood identified for exterior use and meeting the requirements of Section 2303.2 of the International Building Code.
3. Ignition-resistant building materials in accordance with Section 503.2.

Add new text as follows:

504.7.1 Walking surfaces of decks. The walking surface material of decks, porches, balconies and stairs shall be constructed of one of the following:

1. Approved noncombustible materials.
2. Fire-retardant-treated wood identified for exterior use and meeting the requirements of Section 2303.2 of the International Building Code.
3. Ignition-resistant building materials in accordance with Section 503.2.
4. Materials tested in accordance with ASTM E2632 and meeting the conditions of acceptance in Section 504.7.1.1. If abutting an exterior wall that otherwise complies with this chapter, the portion of the exterior wall covering material abutting the walking surface shall have a Class A flame spread index when tested in accordance with ASTM E84 or UL 723 and shall extend to a minimum height of 24 inches above the walking surface and a minimum of 12 inches below the walking surface.

507.1.1 Conditions of Acceptance. ASTM E2632 shall be conducted in triplicate and the peak heat release rate of each test shall be less than or equal to 25 kW per square foot of deck area (269 kW per square meter of deck area).

Add new standard(s) follows:

ASTM

ASTM International
100 Barr Harbor Drive, P.O. Box
C700
West Conshohocken PA 19428-
2959

E2632/E2632M-13e1:

Standard Test Method for Evaluating the Under-Deck Fire Test Response of Deck Materials

Reason:

This proposal includes a fire performance requirement by adding a ANSI Consensus Standard specifically developed to qualify exterior decks for Wildland-UrbanInterface fire performance. ASTM E2632, "Standard Test Method for Evaluating the Under-Deck Fire Test Response of Deck Materials". This test method was developed in response to recommendations developed by the California Office of the State Fire Marshal (OSFM) regarding the performance of decking materials in a wildland fire (exterior wildfire exposure). The ASTM E2632 test method addresses the case where a brand is blown or a surface fire extends under a deck and onto combustible material causing flaming combustion that may lead to penetration through the siding or some other vulnerable point of the main structure. The test is a practical attempt to simulate the case where combustible material resides beneath a structure and can become involved in a wildland fire event. The major concern about the ignition of decking is the hazard that it presents

to the habitable structure. Decking is usually configured so that it is capable of being threatened by two potential sources of ignition: brands on the surface of the decking and flaming material underneath the structure. It has been shown that in a typical Wildland-Urban Interface fire, burning brands can land on a deck causing combustion leading to flaming combustion. The flames impinge on the wall of the structure causing penetration at a vulnerable point into the structure. This proposal not only requires the decking material to be limited to a peak heat release rate of 25kw per square foot but adds additional requirements to provide noncombustible and ignition resistant construction to a height of 24 inches above the deck and 12 inches below the deck to protect the structure from any flaming caused by a burning brand landing on an exterior deck surface. The additional requirement requiring a Class A covering material to a height of 24 inches above the walking surface and 12 inches below, have been added to specifically address recent testing conducted to examine potential vulnerabilities of wood decks to continuous, wind-driven firebrand showers. ASTM E2632 test method provides for several conditions that must be met to pass the performance criteria including: a limited heat release rate (HHR); absence of sustained flaming or glowing combustion; and absence of structural failure of the deck board. Smaller values of heat release rate reflect lower combustibility than larger values. This proposal uses the same acceptance criteria as the State of California SFM office which specifies a maximum net peak heat release of (no more than) 25 kW/ft² [269 kW/m²] for deck boards. For comparison, the HHR for a large juniper bush can be as high as 1000 kW.

Cost Impact

The code change proposal will not increase or decrease the cost of construction .

This proposal allows different materials to be testing to comply with the WUI decking standards and will not increase the cost of construction over current required methods of construction.

Analysis: A review of the standard proposed for inclusion in the code, ASTM E2632/E2632M-13e1 Standard Test Method for Evaluating the Under-Deck Fire Test Response of Deck Materials, with regard to the ICC criteria for referenced standards (Section 3.6 of CP#28) will be posted on the ICC website on or before April 2, 2018.

Internal ID: 2344

WUIC10-18

IWUIC: 504.7.1 (New), 505.7.1 (New), 07

Proponent: John Woestman, Kellen Co., representing Composite Lumber Manufacturers Association (CLMA)
(jwoestman@kellencompany.com)

2018 International Wildland-Urban Interface Code

Add new text as follows:

504.7.1 Walking surfaces of unenclosed accessory structures. Walking surfaces of unenclosed accessory structures shall comply with Section 504.7 or shall comply with the following:

1. Materials tested in accordance with ASTM E2632 / E2632M with an effective peak heat release rate not more than 25 kW/ft² (269 kW/m²), and
2. Materials tested in accordance with ASTM E84 with a Class B flame spread rating or materials where installed abutting an exterior wall, the exterior wall surface for a minimum height of 24 inches above the walking surface of the deck shall be either approved noncombustible materials or ignition-resistant materials in accordance with Section 503.2.

505.7.1 Walking surfaces of unenclosed accessory structures. Walking surfaces of unenclosed accessory structures shall comply with Section 504.7 or shall comply with the following:

1. Materials tested in accordance with ASTM E2632 / E2632M with an effective peak heat release rate not more than 25 kW/ft² (269 kW/m²), and
2. Materials tested in accordance with ASTM E84 with a Class B flame spread rating or materials where installed abutting an exterior wall, the exterior wall surface for a minimum height of 24 inches above the walking surface of the deck shall be either approved noncombustible materials or ignition-resistant materials in accordance with Section 503.2.

Add new standard(s) follows:

ASTM

ASTM International
100 Barr Harbor Drive, P.O. Box
C700
West Conshohocken PA 19428-
2959

E2632/E2632M-13e1:

Standard Test Method for Evaluating the Under-Deck Fire Test Response of Deck Materials

Reason:

This proposal aligns with current requirements of the California Chapter 7A, and includes an option where wall material may be required to be either noncombustible or ignition-resistant.

This proposal seeks to introduce practical and realistic performance requirements for materials used for the walking surfaces of unenclosed accessory structures (i.e. exterior decks) in wildland-urban interface areas. This proposal introduces ASTM E2632, commonly known as the under-deck fire test, to the IWUIC.

The requirements rely on a fire test specifically designed to test and evaluate the performance of decking when constructed as a deck assembly in simulated WUI fire exposure. While this is different than the ASTM E84 test of Section 503.2 for ignition-resistant building materials, the test configuration and test requirements of ASTM E2632 were developed specifically for deck materials in WUI applications.

The ASTM E2632 test procedure requires constructing a small deck structure (joists and deck boards) consistent with the manufacturer's installation instructions and then this deck structure is placed over a burner. The flames and heat from the ignited burner are designed to simulate combustibles burning under a deck which frequently occurs during a WUI fire. The test deck structure is subject to the intense flame and heat from the burner for 3 minutes, and the fire performance of the decking is evaluated for the next 40 minutes to determine the response of the decking.

It is our understanding that based on testing of many decking products using the ASTM E2632 test method, it has been consistently observed that products meeting the conditions of acceptance as referenced in the proposed code change (an effective peak heat release rate not more than 25 kW/ft² (269 kW/m²) produce a limited level of heat release

during the flame exposure, with flames self-extinguishing shortly after the flame source is removed. This test method and acceptance criteria successfully differentiates "passing" products from those where sustained flaming and progressive fire growth occurs, presenting an unacceptable ignition hazard to the adjoining structure.

Cost Impact

The code change proposal will decrease the cost of construction .

This proposal includes what may be considered "right sized" fire performance requirements for exterior decking products (walking surfaces of unenclosed accessory structures). As such, additional decking products may become available in the market and the cost of decking products may be reduced.

Analysis: A review of the standard proposed for inclusion in the code, ASTM E2632/E2632M-13e1 Standard Test Method for Evaluating the Under-Deck Fire Test Response of Deck Materials, with regard to the ICC criteria for referenced standards (Section 3.6 of CP#28) will be posted on the ICC website on or before April 2, 2018.

Internal ID: 2364

WUIC11-18

IWUIC: 505.2

Proponent: Marcelo Hirschler, GBH International, representing GBH International (gbhint@aol.com)

2018 International Wildland-Urban Interface Code

Revise as follows:

505.2 Roof covering. Roofs shall have a roof assembly that complies with not less than a Class ~~B~~A rating when tested in accordance with ASTM E108 or UL 790, or an *approved noncombustible roof covering*. For roof coverings where the profile allows a space between the roof covering and roof decking, the space at the eave ends shall be firestopped to preclude entry of flames or embers, or have one layer of 72- pound (32.4 kg) mineral-surfaced, nonperforated cap sheet complying with ASTM D3909 installed over the combustible decking.

Reason:

Recent wildfires have demonstrated that burning embers are the key reason for transmission of fire from building to building. The key concern are clearly surfaces that are horizontal (such as decks or some roofs) or at a relatively small angle (such as roofs). Therefore, it is important that roof assemblies in wildland urban interface areas exhibit the best fire classification. This proposal requires that roofs in Class 2 ignition-resistant construction should have a Class A rating in accordance with ASTM E108. There can never be assurance, of course, that a better fire classification will ensure that fires don't spread but it is clear that the probability of fire spread will be lower if the fire performance of the roof assembly is better.

A separate proposal handles the terminology associated with this section, which is inconsistent but this proposal is of a technical nature.

Cost Impact

The code change proposal will increase the cost of construction .

This proposal will require that roof assemblies meet a more severe fire rating in accordance with ASTM E108.

Internal ID: 785

WUIC12-18

IWUC: 505.5, 505.5 (New), 505.5.1 (New), 07

Proponent: David Tyree, American Wood Council, representing American Wood Council (dtyree@awc.org)

2018 International Wildland-Urban Interface Code

Delete without substitution:

~~**505.5 Exterior walls.** Exterior walls of buildings or structures shall be constructed with one of the following methods:~~

- ~~1. Materials approved for not less than 1-hour fire-resistance-rated construction on the exterior side.~~
- ~~2. Approved noncombustible materials.~~
- ~~3. Heavy timber or log wall construction.~~
- ~~4. Fire-retardant treated wood on the exterior side. The fire-retardant treated wood shall be labeled for exterior use and meet the requirements of Section 2303.2 of the International Building Code.~~
- ~~5. Ignition-resistant materials on the exterior side.~~

~~Such material shall extend from the top of the foundation to the underside of the roof sheathing.~~

Add new text as follows:

505.5 Exterior walls. Exterior walls of buildings or structures shall be tested in accordance with ASTM E2707 and shall comply with the conditions of acceptance in Section 505.5.1.

Exceptions:

1. One layer of 5/8" gypsum sheathing applied behind the exterior wall covering or cladding on the exterior side of the framing.
2. Materials approved for not less than 1-hour fire-resistance-rated construction on the exterior side of the wall assembly when tested in accordance with ASTM E119.

Exterior wall coverings shall have a Class B flame spread index and shall extend from the top of the foundation to the underside of the roof sheathing.

505.5.1 Conditions of Acceptance when tested in accordance with ASTM E2707. The test shall be conducted in accordance with ASTM E2707 and the conditions of acceptance in items 1 and 2 below shall be met.

1. Absence of flame penetration through the wall assembly at any time.
2. Absence of glowing combustion on the unexposed side of the assembly at any time during the 70-min test.

Add new standard(s) follows:

ASTM

ASTM International
100 Barr Harbor Drive, P.O. Box
C700
West Conshohocken PA 19428-
2959

E2707-15:

Standard Test Method for Determining Fire Penetration of Exterior Wall Assemblies Using a Direct Flame Impingement Exposure

Reason:

This proposal includes a wall assembly fire performance requirement by adding ASTM consensus standard, ASTM E2707, "Standard Test Method for Determining Fire Penetration of Exterior Wall Assemblies Using a Direct Flame Impingement Exposure" as the ASTM test method for the acceptable fire performance of exterior wall assemblies in WUI areas. Exterior sides of wall assemblies that meet 1-hour fire resistance rating in accordance with ASTM E119 is proposed to be left as currently referenced. All other requirements that are not based on an exterior wall fire performance test are proposed to be deleted. WUI exterior wall fire performance is dependent on the cladding on the wall as well as its method of installation. Requiring the exterior wall systems to be tested in accordance with

ASTM E2707 or ASTM E119 would add the method of installation, including joints, to compliance criteria.

ASTM E2707 test method measures the ability of the wall system to resist fire penetration from the exterior into the wall cavity or unexposed side of the test assembly under the conditions of exposure. This test method was developed in response to recommendations developed by the California Office of the State Fire Marshal (SFM) and the International Wildland-Urban Interface Code (IWUIC) regarding the enhancement of exterior fire protection of structures in a wildland fire (exterior wildfire exposure). This proposal establishes performance criteria for materials to be used on the exterior buildings, structures, and detached accessory structures. While this test method is intended to address one component of an exterior wildfire exposure, that is, exterior walls exposed to direct flame impingement the proposal goes on to regulate the flame spread of the materials applied to the exterior wall. The purpose of this standard is to provide a definitive set of procedures for the evaluation and measurement of the resistance to fire penetration of exterior wall structures. The test is a practical attempt to simulate the case where ignition of flammable materials (plants, trash, a deck or shed, etc.) might be adjacent to a building.

Exterior sides of wall assemblies that meet 1-hour fire resistance rating in accordance with ASTM E119 is proposed to be left as currently referenced. A second option of providing a layer of 5/8" gypsum sheathing is consistent with this requirement but gives a prescriptive solution to requiring the test. All other requirements that are not based on an exterior wall fire test ASSEMBLIES are proposed to be deleted. WUI exterior wall fire performance is dependent on the cladding material as well as its method of installation. Requiring that exterior wall systems be tested in accordance with ASTM E2707 or ASTM E119 would add the method of installation to compliance criteria.

A 10-min 150-kW exposure was used for the siding-sheathing combinations, followed by an additional 60- min observation to detect any smoldering combustion. The use of infrared photography of the back of the test wall was used to reveal development of increasing temperatures or persisting hot spots. Other tests were run on solely cladding or sheathing, where the burner was left on until failure to determine the weak points in various materials. Most of the siding-sheathing assemblies exhibited acceptable performance. However, the hardboard siding failed because it burned and warped away from the sheathing, exposing it to flames. For the siding-only tests flame penetration occurred at joints for "combustible" siding. The nature of the siding joints had a substantial effect on relative performance. Most vulnerable was the plain bevel, while rabbeted and shiplap joints were increasingly resistant to flame-through. Tests on different types of siding materials including but not limited to; combustible, heavy timber, fire retardant treated wood and ignition resistant materials should also require testing in accordance with this standard since they were grandfathered in with the exceptions and have never been tested in our knowledge. It is thought that the type of joints using these construction materials will also have a questionable response depending of construction procedure and should also be tested to gain acceptance.

Additionally, it is recognized that the flame spread of the wall material is also very important to the wall performance in Wildland Urban Interface events. With this proposal BOTH the fire penetration through the exterior wall covering assembly into the wall cavity, and surface flame spread of wall covering material are taken into consideration. The current requirement pertains to exterior wall covering material without consideration of the exterior wall assembly performance. Qualifying just the wall covering material may not necessarily assure the safety from a wildland fire exposure. It has been shown that joints are a real weakness in the WUI envelope protection and this proposal addresses that concern. The exception to have an exterior wall assembly tested in accordance with ASTM E2707 is to allow assemblies approved for not less than 1-hour fire-resistance construction applied to the exterior side of the wall assembly or provide a layer of gypsum board as a part of the exterior wall covering assembly.

It is also reasonable to assume that accelerated aging/weathering tests will be required by an AHJ or listing agency as it is important to evaluate the permanence of the fire retardant properties of the product. The aging process will be defined by the intended end-use application and the materials content of the product being tested. Since the proposed test method is applicable to a wide range of products or assemblies, it is not reasonable to assume that all materials should be subjected to the same accelerated aging/weathering process. Test Method ASTM D2898 has long been used as an accelerated weathering process with fire retardant treated lumber products where leaching of chemicals may be an issue. For a product comprised of 100 % plastic, where leaching may not be an issue, some other test method may be appropriate. There are several different accelerated aging/ weathering procedures available. The effectiveness of these procedures vary with changes in the composition of the materials being aged. The language within the standard is worded so that accelerated aging/weathering is not required in all cases, but is required where such results are a condition of acceptance for a product to be used in a code regulated application. As such, the language provides the flexibility needed for the range of materials being used for exterior wall applications.

This proposal places the ASTM decking performance standards into a lower Wildland-Urban Interface Fire classification, Class 2 Ignition-Resistant Construction. The first step to determining the Fire Hazard Severity is to determine if the site is in Low, Moderate,

High or Extreme Hazard Area. Most fire departments have a fire hazard map. Next you determine if a conforming water supply and a defensible space are provided. Then you take this information and apply it to Table 503.1 to determine the required ignition-resistant construction. Depending on nonconforming or conforming water supply and defensible

space you may be able to modify your ignition resistant construction requirements. Upon examination of Table 503.1, Class 2 Ignition Resistant Construction is only permitted in moderate hazard areas with a conforming water supply or a conforming defensible space. In high hazard areas,

Class 2 Ignition Resistant Construction is only permitted where a conforming water AND defensible space is provided. In an extreme hazard area, you must have a conforming water supply and 1.5 times the required defensible space. Materials used for construction are only one consideration in wildland-urban interface fires.

Other considerations which are equally or more important are providing an adequate water supply and defensible space. Without either of these other considerations, the structures have little or no chance of survival regardless of construction. Per Section 502.2 of the International Wildland-Urban Interface Code, Fire Hazard Severity can be reduced by implementing an approved Vegetation Management Plan. Vegetation management plans shall be provided describing all actions that will be taken to prevent a fire from being carried toward or away from the building. Elements of the plan should include removal of slash, snags, vegetation that may grow into overhead electrical lines, other ground fuels, ladder fuels and dead trees, and the thinning of live trees. Additionally, a plan for maintaining the proposed fuel reduction measures should be provided. Defensible space plans must be submitted to the code official for review and approval as part of the plans required for a permit. In other words, these considerations must be considered to provide a structure that can withstand a WUI fire.

Cost Impact

The code change proposal will not increase or decrease the cost of construction .

This proposal places an ASTM WUI Standard for exterior walls in the code and will not increase or decrease the cost of construction in these areas.

Analysis: A review of the standard proposed for inclusion in the code, ASTM E2707-15 Standard Test Method for Determining Fire Penetration of Exterior Wall Assemblies Using a Direct Flame Impingement Exposure, with regard to the ICC criteria for referenced standards (Section 3.6 of CP#28) will be posted on the ICC website on or before April 2, 2018.

Internal ID: 1063

WUIC13-18

IWUIC: 505.7

Proponent: Marcelo Hirschler, GBH International, representing GBH International (gbhint@aol.com)

2018 International Wildland-Urban Interface Code

Revise as follows:

505.7 Appendages and projections. *Unenclosed accessory structures* attached to buildings with habitable spaces and projections, such as decks, shall be not less than 1-hour fire-resistance-rated construction, heavy timber construction or constructed of one of the following:

1. *Approved noncombustible* materials.
2. Fire-retardant-treated wood identified for exterior use and meeting the requirements of Section 2303.2 of the International Building Code.
3. Ignition-resistant building materials in accordance with Section 503.2.

Exception: Coated materials shall not be used as the walking surface of decks.

Reason:

It is possible to create ignition-resistant materials that are the result of coating the front and back of certain panels (such as wood panels) and that meet the requirements. Such materials are typically fully suitable for use in most applications where ignition resistant materials are called for except for walking surfaces because of the probability of erosion after a certain period of use.

Therefore, if the coating is being eroded, the fire safety will decrease.

Cost Impact

The code change proposal will increase the cost of construction .

It is unlikely that coated materials are being used as decking materials, but if they are used, the proposed change would eliminate an option.

Internal ID: 869

WUIC14-18

IWUC: 505.7, 505.7.1 (New), 505.7.1.1 (New), 07

Proponent: Kuma Sumathipala, American Wood Council, representing American Wood Council
(ksumathipala@awc.org)

2018 International Wildland-Urban Interface Code

Revise as follows:

505.7 Appendages and projections. *Unenclosed accessory structures* attached to buildings with habitable spaces ~~and, projections, such as, decks, other than walking surfaces of decks,~~ shall be not less than 1-hour fire-resistance-rated construction, heavy timber construction or constructed of one of the following:

1. *Approved noncombustible materials.*
2. Fire-retardant-treated wood identified for exterior use and meeting the requirements of Section 2303.2 of the International Building Code.
3. Ignition-resistant building materials in accordance with Section 503.2.

Add new text as follows:

505.7.1 Walking surfaces of Decks. The walking surface material of decks, porches, balconies and stairs shall be constructed of one of the following:

1. Approved noncombustible materials.
2. Fire-retardant-treated wood identified for exterior use and meeting the requirements of Section 2303.2 of the International Building Code.
3. Ignition-resistant building materials in accordance with Section 503.2.
4. Materials tested in accordance with ASTM E2632 and meeting the conditions of acceptance in Section 505.7.1.1. If abutting an exterior wall that otherwise complies with this chapter, the portion of the exterior wall covering material abutting the walking surface shall have a Class A flame spread index when tested in accordance with ASTM E84 or UL 723 and shall extend to a minimum height of 24 inches above the walking surface and a minimum of 12 inches below the walking surface.

505.7.1.1 Conditions of acceptance. ASTM E2632 shall be conducted in triplicate and the peak heat release rate of each test shall be less than or equal to 25 kW per square foot of deck area (269 kW per square meter of deck area).

Add new standard(s) follows:

ASTM

ASTM International
100 Barr Harbor Drive, P.O. Box
C700
West Conshohocken PA 19428-
2959

E2632/E2632M-13e1:

Standard Test Method for Evaluating the Under-Deck Fire Test Response of Deck Materials

Reason:

This proposal includes a fire performance requirement by adding a ANSI Consensus Standard specifically developed to qualify exterior decks for Wildland Urban Interface fire performance. ASTM E2632, "Standard Test Method for Evaluating the Under-Deck Fire Test Response of Deck Materials". This test method was developed in response to recommendations developed by the California Office of the State Fire Marshal (OSFM) regarding the performance of decking materials in a wildland fire (exterior wildfire exposure). The ASTM E2632 test method addresses the case where a brand is blown or a surface fire extends under a deck and onto combustible material causing flaming combustion that may lead to penetration through the siding or some other vulnerable point of the main structure. The test is a practical attempt to simulate the case where combustible material resides beneath a structure and can become involved in a wildland fire event. The major concern about the ignition of decking is the hazard that it presents

to the habitable structure. Decking is usually configured so that it is capable of being threatened by two potential sources of ignition: brands on the surface of the decking and flaming material underneath the structure. It has been shown that in a typical Wildland Urban Interface fire, burning brands can land on a deck causing combustion leading to flaming combustion. The flames impinge on the wall of the structure causing penetration at a vulnerable point into the structure. This proposal not only requires the decking material to be limited to a peak heat release rate of 25kw per square foot but adds additional requirements to provide noncombustible and ignition resistant construction to a height of 24 inches above the deck and 12 inches below the deck to protect the structure from any flaming caused by a burning brand landing on an exterior deck surface. The additional requirement requiring a Class A covering material to a height of 24 inches above the walking surface and 12 inches below, have been added to specifically address recent testing conducted to examine potential vulnerabilities of wood decks to continuous, wind-driven firebrand showers. ASTM E2632 test method provides for several conditions that must be met to pass the performance criteria including: a limited heat release rate (HHR); absence of sustained flaming or glowing combustion; and absence of structural failure of the deck board. Smaller values of heat release rate reflect lower combustibility than larger values. This proposal uses the same acceptance criteria as the State of California SFM office which specifies a maximum net peak heat release of (no more than) 25 kW/ft² [269 kW/m²] for deck boards. For comparison, the HHR for a large juniper bush can be as high as 1000 kW.

Cost Impact

The code change proposal will not increase or decrease the cost of construction .

This proposal allows different materials to be testing to comply with the WUI decking standards and will not increase the cost of construction over current required methods of construction.

Analysis: A review of the standard proposed for inclusion in the code, ASTM E2632/E2632M-13e1 Standard Test Method for Evaluating the Under-Deck Fire Test Response of Deck Materials, with regard to the ICC criteria for referenced standards (Section 3.6 of CP#28) will be posted on the ICC website on or before April 2, 2018.

Internal ID: 2365

WUIC15-18

IWUIC: 505.7, 505.7.1 (New), 505.7.1.1 (New), 07

Proponent: David Tyree, American Wood Council, representing American Wood Council (dtyree@awc.org)

2018 International Wildland-Urban Interface Code

Revise as follows:

505.7 Appendages and projections. *Unenclosed accessory structures* attached to buildings with habitable spaces and projections, such as decks, shall have walking surfaces complying with Section 505.7.1 or shall be not less than 1-hour fire-resistance-rated construction, heavy timber construction or constructed of one of the following:

1. *Approved noncombustible* materials.
2. Fire-retardant-treated wood identified for exterior use and meeting the requirements of Section 2303.2 of the International Building Code.
3. Ignition-resistant building materials in accordance with Section 503.2.

Add new text as follows:

505.7.1 Deck Materials. The walking surface material of decks, porches, balconies and stairs shall comply with Section 505.7 or shall be tested in accordance with ASTM E2632 and shall meet the acceptance criteria in Section 505.7.1.1 . If abutting an exterior wall that otherwise complies with this chapter, the portion of the exterior wall covering material abutting the walking surface shall have a Class A flame spread index when tested in accordance with ASTM E84 or UL 723 and shall extend material to a minimum height of 24 inches above the walking surface and a minimum of 12 inches below the walking surface.

505.7.1.1 Conditions of acceptance when tested in accordance with ASTM E2632. The test shall be conducted in triplicate and the peak heat release rate of each test shall be less than or equal to 25 kW per square foot of deck area (269 kW per square meter of deck area).

Add new standard(s) follows:

ASTM

ASTM International
100 Barr Harbor Drive, P.O. Box
C700
West Conshohocken PA 19428-
2959

E2632/E2632M—13e1:

Standard Test Method for Evaluating the Under-Deck Fire Test Response of Deck Materials

Reason:

This proposal includes a fire performance requirement by adding a ANSI Consensus Standard specifically developed for Wildland-Urban Interface fires. ASTM E2632, "Standard Test Method for Evaluating the Under-Deck Fire Test Response of Deck Materials". This test method was developed in response to recommendations developed by the California Office of the State Fire Marshal (OSFM) regarding the performance of decking materials in a wildland fire (exterior wildfire exposure). The ASTM E2632 test method addresses the case where a brand is blown or a surface fire extends under a deck and onto combustible material causing flaming combustion that may lead to penetration through the siding or some other vulnerable point of the main structure. The test is a practical attempt to simulate the case where combustible material resides beneath a structure and can become involved in a wildland fire event.

The major concern about the ignition of decking is the hazard that it presents to the habitable structure. Decking is usually configured so that it is capable of being threatened by two potential sources of ignition: brands on the surface of the decking and flaming material underneath the structure. It has been shown that in a typical Wildland-Urban Interface fire, burning brands can land on a deck causing combustion leading to flaming combustion. The flames impinge on the wall of the structure causing penetration at a vulnerable point into the structure. This proposal not only requires the decking material to be limited to a peak heat release rate of 25kw per square foot but adds additional requirements to provide non-combustible and ignition resistant construction to a height of 24 inches above the deck and 12 inches below the deck to protect the structure from any flaming caused by a burning brand landing on an exterior deck surface. The additional requirement requiring a Class A covering material to a height of 24 inches above

the walking surface and 12 inches below, have been added to specifically address recent testing conducted to examine potential vulnerabilities of wood decks to continuous, wind-driven firebrand showers. ASTM E2632 test method provides for several conditions that must be met to pass the performance criteria including: a limited heat release rate (HHR); absence of sustained flaming or glowing combustion; and absence of structural failure of the deck board. Smaller values of heat release rate reflect lower combustibility than larger values. This proposal uses the same acceptance criteria as the State of California SFM office which specifies a maximum net peak heat release of (no more than) 25 kW/ft² [269 kW/m²] for deck boards. For comparison, the HHR for a large juniper bush can be as high as 1000 kW.

Cost Impact

The code change proposal will not increase or decrease the cost of construction .

This proposal allows different materials to be tested to comply with the WUI decking standards and will not increase the cost of construction over current required methods of construction.

Analysis: A review of the standard proposed for inclusion in the code, ASTM E2632/E2632M-13e1 Standard Test Method for Evaluating the Under-Deck Fire Test Response of Deck Materials, with regard to the ICC criteria for referenced standards (Section 3.6 of CP#28) will be posted on the ICC website on or before April 2, 2018.

Internal ID: 1065

WUIC16-18

IWUIC: 506.2

Proponent: Marcelo Hirschler, representing GBH International (gbhint@aol.com)

2018 International Wildland-Urban Interface Code

Revise as follows:

506.2 Roof covering. Roofs shall have a roof assembly that complies with not less than a Class ~~C~~B rating when tested in accordance with ASTM E108 or UL 790 or an *approved noncombustible roof* covering. For roof coverings where the profile allows a space between the roof covering and roof decking, the space at the eave ends shall be firestopped to preclude entry of flames or embers, or have one layer of 72- pound (32.4 kg) mineral-surfaced, nonperforated cap sheet complying with ASTM D3909 installed over the combustible decking.

Reason:

Recent wildfires have demonstrated that burning embers are the key reason for transmission of fire from building to building. The key concern are clearly surfaces that are horizontal (such as decks or some roofs) or at a relatively small angle (such as roofs). Therefore, it is important that roof assemblies in wildland urban interface areas exhibit the best fire classification. This proposal requires that roofs in Class 3 ignition-resistant construction should have a Class B rating in accordance with ASTM E108. This proposal acknowledges that Class 3 ignition-resistant construction provides less protection than Class 1 or 2 and, therefore, recommends that it be changed from Class C roof fire classification to Class B roof fire classification and not to Class A. There can never be assurance, of course, that a better fire classification will ensure that fires don't spread but it is clear that the probability of fire spread will be lower if the fire performance of the roof assembly is better.

A separate proposal handles the terminology associated with this section, which is inconsistent but this proposal is of a technical nature.

Cost Impact

The code change proposal will increase the cost of construction .

This proposal will require that roof assemblies meet a more severe fire rating in accordance with ASTM E108.

Internal ID: 789

CCC-F11-18

IFC: 3806.2

Proponent: Kevin Scott, representing KH Scott & Associates LLC (khscottassoc@gmail.com)

2018 International Fire Code

Revise as follows:

3806.2 Hazardous materials storage and use. Storage and use of hazardous materials within *control areas* in new and existing laboratories equipped with an *automatic sprinkler system* shall be in accordance with this section and Chapters 50 through 67, as applicable.

Exception: Existing laboratories in buildings equipped throughout with an automatic sprinkler system meeting requirements for laboratory suites are permitted to comply with Section 3804.

Reason:

This is an editorial change to correct the term for "automatic sprinkler system."

Cost Impact

The code change proposal will not increase or decrease the cost of construction .

This proposal is editorial.

Internal ID: 2355

CCC-F4-18

IFC: 2311.8.4.4

Proponent: Kevin Scott, representing KH Scott & Associates LLC (khscottassoc@gmail.com)

2018 International Fire Code

Revise as follows:

2311.8.4.4 Clear space. Motor vehicle repair booths shall be installed so that all parts of the booth ~~provide~~ are provided with ready access for cleaning. A clear area of not less than 3 feet (914 mm) wide shall be maintained on all sides of the motor vehicle repair booth. This clear area shall be kept free of any storage or combustible construction.

Exceptions:

1. This requirement shall not prohibit locating a motor vehicle repair booth closer than 3 feet (914 mm) to or directly against an interior partition, wall or floor/ceiling assembly that has a fire-resistance rating of not less than 1 hour, provided that the motor vehicle repair booth can be adequately maintained and cleaned.
2. This requirement shall not prohibit locating a motor vehicle repair booth closer than 3 feet (914 mm) to an exterior wall or a roof assembly, provided that the wall or roof is constructed of noncombustible material and the motor vehicle repair booth can be adequately maintained and cleaned.

Reason:

This revision clarifies the application of this section.

The booth does not "provide" access; the booth is "provided with" access. This revision clarifies this section.

Cost Impact

The code change proposal will not increase or decrease the cost of construction .

This is clarification. There is no change in code requirements.

Internal ID: 2332

CCC-F8-18

IFC: 3805.2, 3805.3

Proponent: Kevin Scott, representing KH Scott & Associates LLC (khscottassoc@gmail.com)

2018 International Fire Code

Revise as follows:

3805.2 ~~Nonsprinklered laboratories~~ Maximum allowable quantities. The maximum allowable quantities of hazardous materials in storage and use in *control areas* in laboratories located in buildings not equipped throughout with an *automatic sprinkler system* in accordance with Section 903.3.1.1 shall be in accordance with Tables 5003.1.1(1), 5003.1.1(2) and 5003.8.3.2, except as modified by Sections 3805.2.1 and 3805.2.2.

3805.3 ~~Restricted materials automatic~~ Automatic fire detection. An automatic fire detection system shall be installed in all existing laboratories in nonsprinklered buildings in accordance with this section. Detectors shall be connected to the building's fire alarm control unit where a fire alarm system is provided. Detector initiation shall activate the occupant notification system in accordance with Section 907.5 where connected to the building's fire alarm control unit. Activation of the detection system shall sound a local alarm in buildings not equipped with a fire alarm notification system.

Reason:

These revisions are simply to have the section title more appropriately depict the section content.

All of Section 3805 addresses Nonsprinklered Laboratories, so the title of Section 3805.2 is revised to Maximum Allowable Quantities since that is what is regulated in that section.

Section 3805.3 is revised by deleted the words "Restricted Materials" since they do not apply the section at all.

Cost Impact

The code change proposal will not increase or decrease the cost of construction .

There is no change in requirements.

Internal ID: 2314

CCC-E5-18

IBC: 1029.16.1 (IFC[BE] 1029.16.1)

Proponent: Homer Maiel, representing ICC Tri-Chapter (Peninsula, East Bay, Monterey Bay) (hmaiel@gmail.com)

2018 International Building Code

Revise as follows:

1029.16.1 Discontinuous mid-aisle handrails. Where there is seating on both sides of the aisle, the mid-aisle *handrails* shall be discontinuous with gaps or breaks at intervals not exceeding five rows to facilitate access to seating and to permit crossing from one side of the *aisle* to the other. These gaps or breaks shall have a clear width of not less than 22 inches (559 mm) and not greater than 36 inches (914 mm), measured horizontally, and the mid-aisle *handrail* shall have rounded terminations or bends.

Reason:

This merely clarifies the code section.

Cost Impact

The code change proposal will not increase or decrease the cost of construction .

This changes simply clarifies the code provision.

Internal ID: 1061

CCC-P1-18

IPC: 705.2.1

Proponent: Michael Cudahy, representing Plastic Pipe and Fittings Association (mikec@cmservices.com)

2018 International Plumbing Code

Revise as follows:

705.2.1 Mechanical joints. Mechanical joints on drainage ~~pipes~~ pipe shall be made with an elastomeric seal conforming to ASTM C1173, ASTM D3212, or CSA B602. Mechanical joints shall not be installed ~~only in underground~~ above-ground systems unless otherwise *approved*. Joints shall be installed in accordance with the manufacturer's instructions.

705.10.1 Mechanical joints. Mechanical joints on drainage pipe shall be made with an elastomeric seal conforming to ASTM C1173, ASTM D3212 or CSA B602. Mechanical joints shall not be installed in above-ground systems, unless otherwise *approved*. Joints shall be installed in accordance with the manufacturer's instructions.

Reason:

Getting the ABS and PVC sections to correlate. There is slightly different language used.

Cost Impact

The code change proposal will not increase or decrease the cost of construction .

This wording change is essentially editorial and does not change technical requirements.

Internal ID: 983

CCC-G2-18

IBC: 202

Proponent: Michael O'Brian, Chair, representing FCAC (FCAC@iccsafe.org); Ed Kullik, Chair, representing ICC Building Code Action Committee (BCAC@iccsafe.org)

2018 International Building Code

Delete without substitution:

~~**[BG] CABLE-RESTRAINED, AIR-SUPPORTED STRUCTURE.** A structure in which the uplift is resisted by cables or webbings which are anchored to either foundations or dead men. Reinforcing cable or webbing is attached by various methods to the membrane or is an integral part of the membrane. This is not a cable-supported structure.~~

Reason:

The words **CABLE-RESTRAINED, AIR-SUPPORTED STRUCTURE** are not used anywhere in IBC or IFC, except in the definition. The term "air-supported" is defined separately, the term "cable-restrained" is intuitive. The last sentence of the definition is present to make a clear distinction between "cable-restrained", and "cable-supported", yet the term "cable-supported" is also neither defined nor used.

Cost Impact

The code change proposal will not increase or decrease the cost of construction .

This proposal simply deletes an obsolete definition.

Internal ID: 345

CCC-FS5-18

IBC: 715

Proponent: Michael O'Brian, Chair, representing FCAC (fcac@iccsafe.org)

2018 International Building Code

Revise as follows:

SECTION 715 FIRE-RESISTANT JOINT SYSTEMS JOINTS AND VOIDS

Reason:

Section 715 covers more than just fire-resistant rated joint systems, it actually covers both joints and voids. This editorial title change is consistent with the concept of Section 714, entitled Penetrations.

The proposal compliments a proposal which reorganizes Section 715.

This proposal is submitted by the ICC Fire Code Action Committee (FCAC). The FCAC was established by the ICC Board of Directors to pursue opportunities to improve and enhance assigned International Codes with regard to fire safety and hazardous materials in new and existing buildings and facilities and the protection of life and property in wildland urban interface areas. In 2017 the Fire-CAC has held 3 open meetings. In addition, there were numerous conference calls, Regional Work Group and Task Group meetings for the current code development cycle, which included members of the committees as well as any interested parties, to discuss and debate the proposed changes. Related documentation and reports are posted on the FCAC website at: <https://www.iccsafe.org/codes-tech-support/cs/fire-code-action-committee-fcac/>

Cost Impact

The code change proposal will not increase or decrease the cost of construction .

This proposal simply changes the title of the Section.

Internal ID: 324
