



**LA Basin and Orange Empire Chapter
Joint Presentation**
July 1, 2021 – Effective Date



Paul Armstrong, P.E., CBO | Sept 9, 2021



Course Intent

- This course provides a review of important code changes found in the July 2021 Supplement of California Building Code (CBC), California Residential Code (CRC). This webinar is conducted in a workshop format. The course is appropriate for experienced and not-so-experienced users of the CA codes.
- Largest Supplement package of amendments I have ever seen! CBC Vol 1 – 372 pgs., CBC Vol 2 – 172 pgs., CFC – 188 pgs. and CRC – 48 pgs.

Tall Wood or Mass Timber

- Biggest construction material change in many years! CBC only!
- Definition: “**Mass Timber**: Structural elements of Type IV construction primarily of solid, built-up, panelized or engineered wood products that meet the minimum cross section dimensions of Type IV construction.”
- Definition: “**Noncombustible Protection (For Mass Timber)**. Noncombustible material, in accordance with Section 703.5, designed to increase the fire resistance rating and delay the combustion of mass timber.”

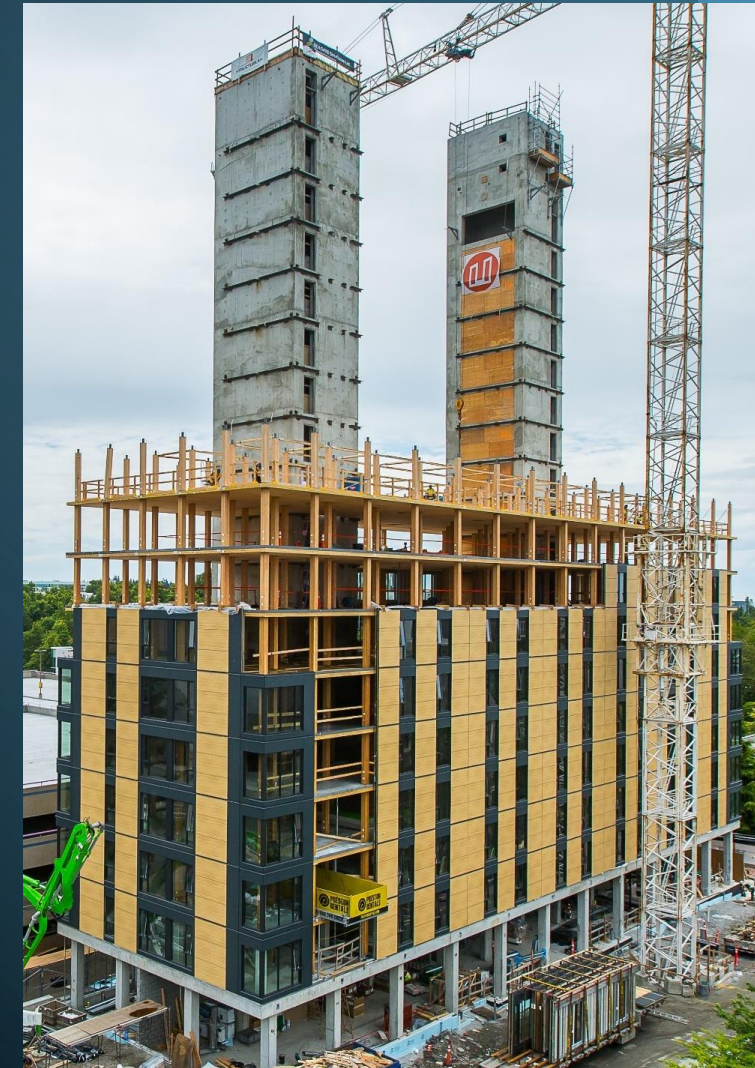

Photo by AWC

Structural Composite Lumber (SCL)



LSL
(laminated strand lumber)



OSL
(oriented strand lumber)

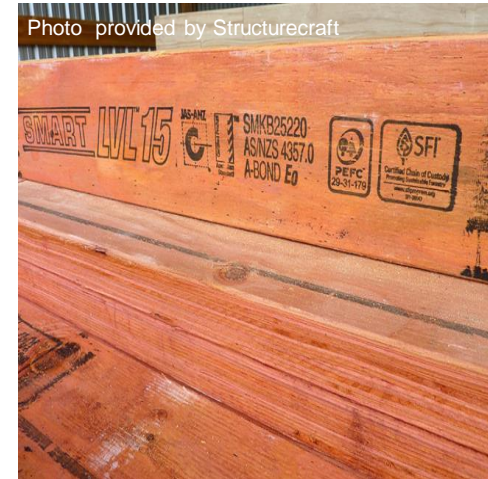

LVL
(laminated veneer lumber)



PSL
(parallel strand lumber)

Recently-Developed Forms of Mass Timber

Cross-Laminated Timber (CLT)



Tall Wood or Mass Timber

- **110.3.12 Type IV-A, IV-B, and IV-C connection protection inspection.** In buildings of Type IV-A, IV-B and IV-C construction, where connection fire resistance ratings are provided by wood cover calculated to meet the requirements of Section 2304.10.1, inspection of the wood cover shall be made after the cover is installed, but before any other coverings or finishes are installed.



2021 IBC – New Construction Types

- IBC 602.4 reflects 3 new construction types
- No changes to existing heavy timber (HT) provisions (formerly Type IV)



Mass Timber Fire Resistance

TABLE 601

BUILDING ELEMENT	TYPE I		TYPE II		TYPE III		TYPE IV				TYPE V	
	A	B	A	B	A	B	A	B	C	HT	A	B
Primary structural frame ^f (see Section 202)	3 ^a	2 ^a	1	0	1	0	3 ^a	2 ^a	2 ^a	HT	1	0
Bearing walls Exterior ^{e, f}	3	2	1	0	2	2	3	2	2	2	1	0
Interior	3 ^a	2 ^a	1	0	1	0	3	2	2	1/HT	1	0
Nonbearing walls and partitions Exterior	See Table 602											
Nonbearing walls and partitions Interior ^d	0	0	0	0	0	0	0	0	0	See Section 2304.11.2	0	0
Floor construction and associated secondary members (see Section 202)	2	2	1	0	1	0	2	2	2	HT	1	0
Roof construction and associated secondary members (see Section 202)	1 1/2 ^b	1 ^{b, c}	1 ^{b, c}	0 ^c	1 ^{b, c}	0	1 1/2	1	1	HT	1 ^{b, c}	0

➤ Type IV A, B and C

➤ Highly rated structural elements

CBC Type IV-A Exterior Wall

- 3-hr FRR for exterior and interior bearing walls (Table 601)
- 2/3 FRR noncombustible protection
- 2-hr FRR noncombustible protection
- 2-hr FRR = 3 layers 5/8" Type X GWB
 - 40-min x 3 layers = 120-min
- Furring channel per AISI S220

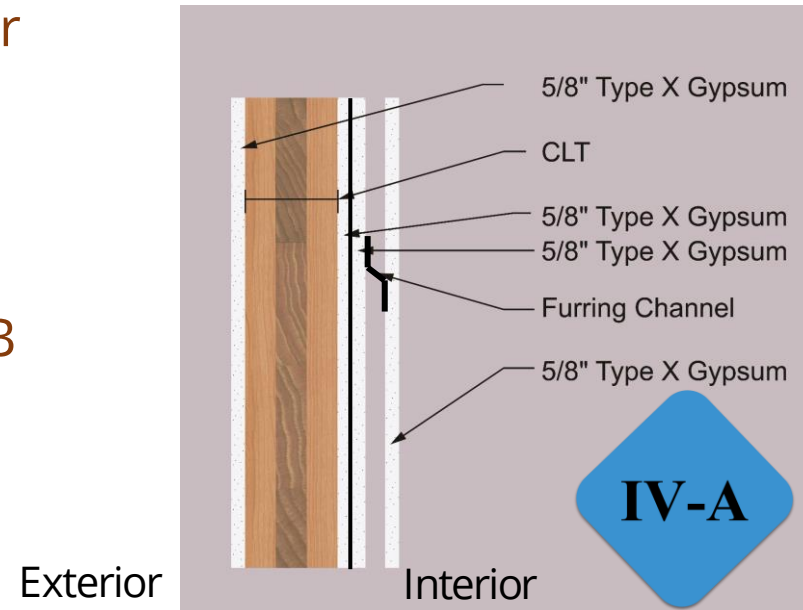

CBC Type IV-B Exterior Wall

- 2-hr FRR for exterior and interior bearing walls (Table 601)
- 2/3 FRR noncom protection = 2 layers 5/8" GB @ 40-min
- 2-hr x 2/3 = 80-min
- 40-min x 2 = 80-min

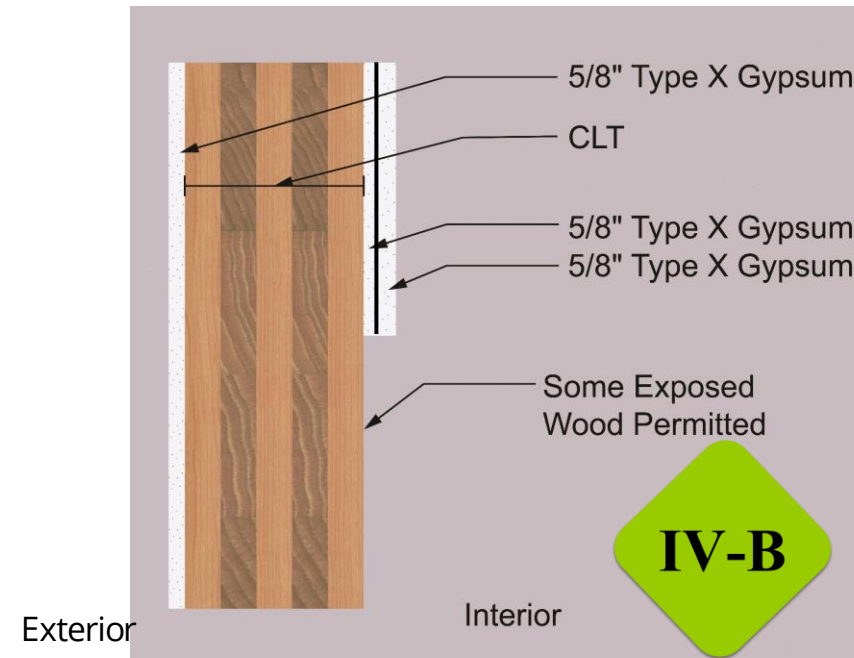

CBC Type IV-C Exterior Wall

- 2-hr FRR for exterior and interior bearing walls (Table 601)
- CLT must be designed for 2-hr FRR if exposed

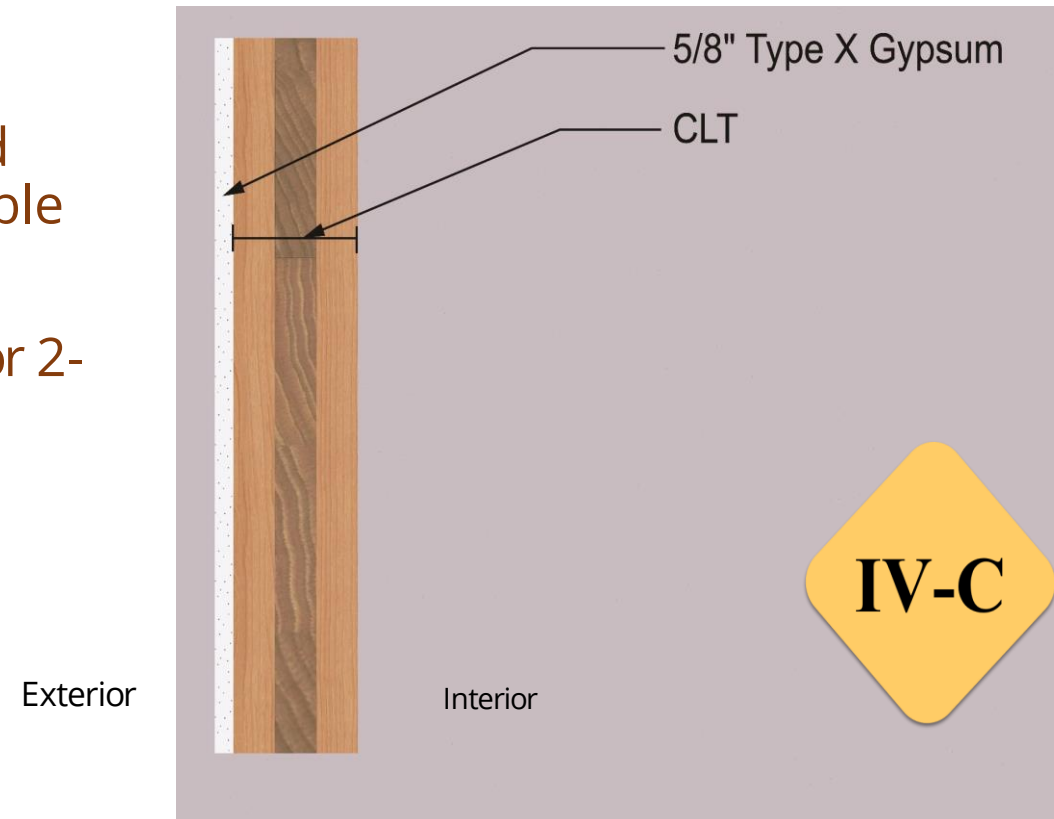

Tall Wood or Mass Timber

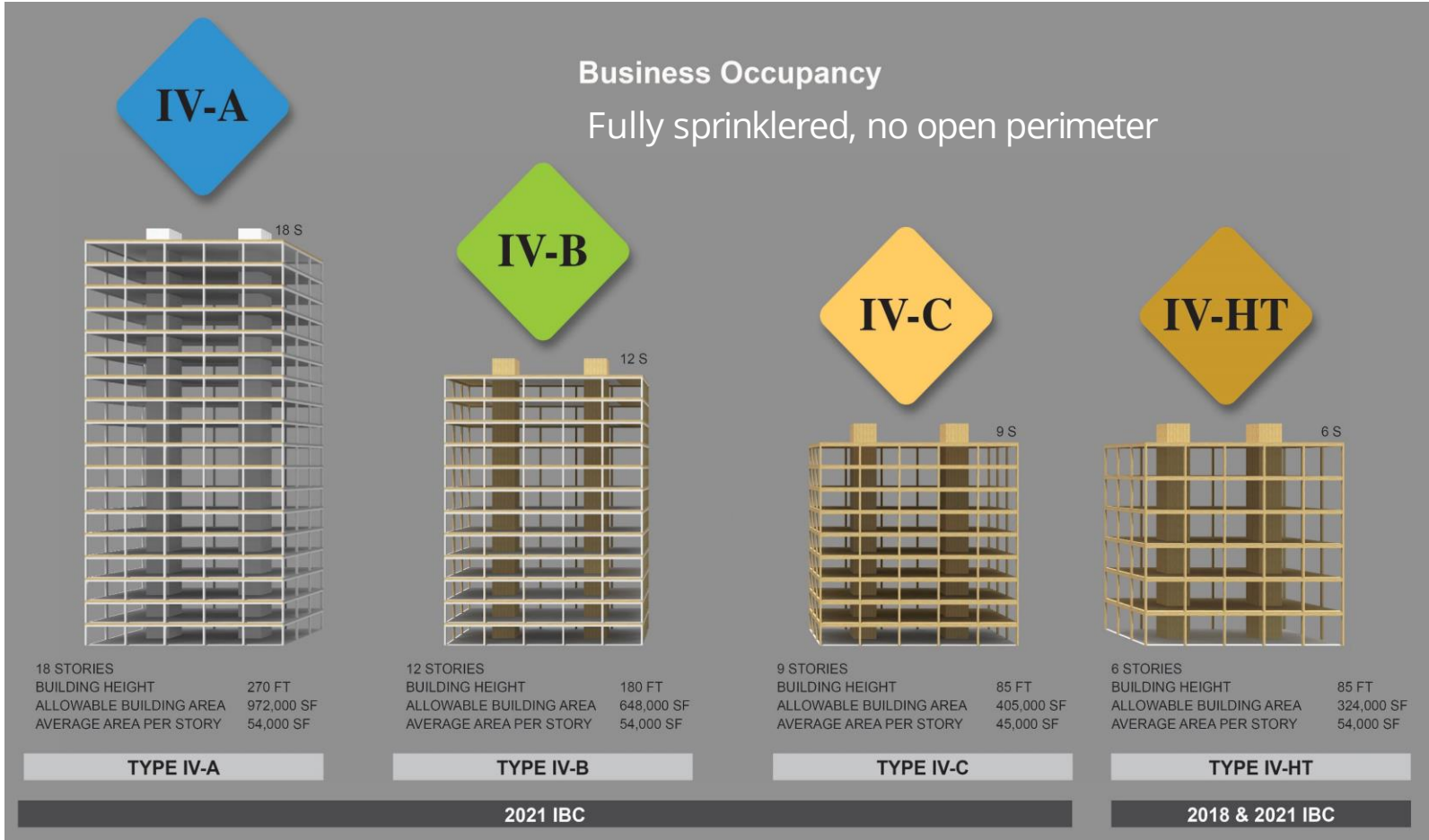

➤ Biggest construction material change in many years!

Mass Timber - Allowable Heights (Ft)

CBC Table 504.3

TABLE 504.3
ALLOWABLE BUILDING HEIGHT IN FEET ABOVE GRADE PLANE^{a, f}

OCCUPANCY CLASSIFICATION	SEE FOOTNOTES	TYPE OF CONSTRUCTION											
		TYPE I		TYPE II		TYPE III		TYPE IV				TYPE V	
		A	B	A	B	A	B	A	B	C	HT	A	B
B, F, M, S, U	NS ^b	UL	160	65	55	65	55	65	65	65	65	50	40
	S	UL	180	85	75	85	75	270	180	85	85	70	60
A, E	NS ^b	UL	160	65	55	65	55	65	65	65	65	50	40
	S (without area increase)	UL	180	85	75	85	75	270	180	85	85	70	60
	S (with area increase)	UL	160	65	55	65	55	250	160	65	65	50	40
R-1 ^h	NS ^d	UL	160	65	55	65	55	65	65	65	65	50	40
	S13D	60	60	60	60	60	60	60	60	60	60	50	40
	S13R	60	60	60	55	60	55	60	60	60	60	50	40
	S (without area increase)	UL	180	85	75	85	75	270	180	85	85	70	60
	S (with area increase)	UL	160	65	55	65	55	250	160	65	65	50	40
R-2 ^h	NS ^d	UL	160	65	55	65	55	65	65	65	65	50	40
	S13R	60	60	60	55	60	55	60	60	60	60	50	40
	S (without area increase)	UL	180	85	75	85	75	270	180	85	85	70	60
	S (with area increase)	UL	160	65	55	65	55	250	160	65	65	60 ^j	40



Sprinklered: IV-B = I-B & IV-A = 1.5 x IV-B with exceptions

Mass Timber - Allowable Heights (Stories) CBC Table 504.4

When Sprinklered:
 Type IV-A = 1.5xIV-B
 Type IV-B = Type IIB
 Type IV-C = varies

TABLE 504.4
 ALLOWABLE NUMBER OF STORIES ABOVE GRADE PLANE^{a, b, c}

OCCUPANCY CLASSIFICATION	SEE FOOTNOTES	TYPE OF CONSTRUCTION												
		TYPE I		TYPE II		TYPE III		TYPE IV			HT	TYPE V		
		A	B	A	B	A	B	A	B	C		A	B	
A-1	NS	UL	5	3	2	3	2	3	3	3	3	3	2	1
	<i>S (without area increase)</i>	UL	6	4	3	4	3	9	6	4	4	4	3	2
	<i>S (with area increase)</i>	UL	5	3	2	3	2	8	5	3	3	3	2	1
A-2	NS	UL	11	3	2	3	2	3	3	3	3	3	2	1
	<i>S (without area increase)</i>	UL	12	4	3	4	3	18	12	6	4	4	3	2
	<i>S (with area increase)</i>	UL	11	3	2	3	2	17	11	5	3	3	2	1
A-3	NS	UL	11	3	2	3	2	3	3	3	3	3	2	1
	<i>S (without area increase)</i>	UL	12	4	3	4	3	18	12	6	4	4	3	2
	<i>S (with area increase)</i>	UL	11	3	2	3	2	17	11	5	3	3	2	1
A-4	NS	UL	11	3	2	3	2	3	3	3	3	3	2	1
	<i>S (without area increase)</i>	UL	12	4	3	4	3	18	12	6	4	4	3	2
	<i>S (with area increase)</i>	UL	11	3	2	3	2	17	11	5	3	3	2	1
A-5	NS	UL	UL	UL	UL	UL	UL	1	1	1	UL	UL	UL	UL
	S	UL	UL	UL	UL	UL	UL	UL	UL	UL	UL	UL	UL	UL
B	NS	UL	11	5	3	5	3	5	5	5	5	5	3	2
	S	UL	12	6	4	6	4	18	12	9	6	6	4	3
R-1 ^h	NS ^d	UL	11	4	4	4	4	4	4	4	4	3	2	
	S13R	4	4					4	4	4				4
	<i>S (without area increase)</i>	UL	12	5	5	5	5	18	12	8	5	4	3	
	<i>S (with area increase)</i>	UL	11	4	4	4	4	17	11	7	4	3	2	
R-2 ^h	NS ^d	UL	11	4	4	4	4	4	4	4	4	3	2	
	S13R	4	4					4	4	4				4
	<i>S (without area increase)</i>	UL	12	5	5	5	5	18	12	8	5	4	3	
	<i>S (with area increase)</i>	UL	11	4	4	4	4	17	11	7	4	4 ^e	2	



Mass Timber - Allowable Heights CBC Table 506.2

Type IV-A = 3xHT
 Type IV-B = 2xHT
 Type IV-C = 1.25xHT

TABLE 506.2
 ALLOWABLE AREA FACTOR (A_f = NS, S1, S13R, S13D or SM, as applicable) IN SQUARE FEET^{a, b, j}

OCCUPANCY CLASSIFICATION	SEE FOOTNOTES	TYPE OF CONSTRUCTION											
		TYPE I		TYPE II		TYPE III		TYPE IV				TYPE V	
		A	B	A	B	A	B	A	B	C	HT	A	B
A-1	NS	UL	UL	15,500	8,500	14,000	8,500	45,000	30,000	18,750	15,000	11,500	5,500
	S1	UL	UL	62,000	34,000	56,000	34,000	180,000	120,000	75,000	60,000	46,000	22,000
	SM (without height increase)	UL	UL	46,500	25,500	42,000	25,500	135,000	90,000	56,250	45,000	34,500	16,500
	SM (with height increase)	UL	UL	15,500	8,500	14,000	8,500	45,000	30,000	18,750	15,000	11,500	5,500
A-2	NS	UL	UL	15,500	9,500	14,000	9,500	45,000	30,000	18,750	15,000	11,500	6,000
	S1	UL	UL	62,000	38,000	56,000	38,000	180,000	120,000	75,000	60,000	46,000	24,000
	SM (without height increase)	UL	UL	46,500	28,500	42,000	28,500	135,000	90,000	56,250	45,000	34,500	18,000
	SM (with height increase)	UL	UL	15,500	9,500	14,000	9,500	45,000	30,000	18,750	15,000	11,500	6,000
A-3	NS	UL	UL	15,500	9,500	14,000	9,500	45,000	30,000	18,750	15,000	11,500	6,000
	S1	UL	UL	62,000	38,000	56,000	38,000	180,000	120,000	75,000	60,000	46,000	24,000
	SM (without height increase)	UL	UL	46,500	28,500	42,000	28,500	135,000	90,000	56,250	45,000	34,500	18,000
	SM (with height increase)	UL	UL	15,500	9,500	14,000	9,500	45,000	30,000	18,750	15,000	11,500	6,000
B	NS	UL	UL	37,500	23,000	28,500	19,000	108,000	72,000	45,000	36,000	18,000	9,000
	S1	UL	UL	150,000	92,000	114,000	76,000	432,000	288,000	180,000	144,000	72,000	36,000
	SM	UL	UL	112,500	69,000	85,500	57,000	324,000	216,000	135,000	108,000	54,000	27,000
R-1 ^b	NS ^d	UL	UL	24,000	16,000	24,000	16,000	61,500	41,000	25,625	20,500	12,000	7,000
	S13R	UL	UL	24,000	16,000	24,000	16,000	61,500	41,000	25,625	20,500	12,000	7,000
	S1	UL	UL	96,000	64,000	96,000	64,000	246,000	164,000	102,500	82,000	48,000	28,000
	SM (without height increase)	UL	UL	72,000	48,000	72,000	48,000	184,500	123,000	76,875	61,500	36,000	21,000
	SM (with height increase)	UL	UL	24,000	16,000	24,000	16,000	61,500	41,000	25,625	20,500	12,000	7,000
R-2 ^b	NS ^d	UL	UL	24,000	16,000	24,000	16,000	61,500	41,000	25,625	20,500	12,000	7,000
	S13R	UL	UL	24,000	16,000	24,000	16,000	61,500	41,000	25,625	20,500	12,000	7,000
	S1	UL	UL	96,000	64,000	96,000	64,000	246,000	164,000	102,500	82,000	48,000	28,000
	SM (without height increase)	UL	UL	72,000	48,000	72,000	48,000	184,500	123,000	76,875	61,500	36,000	21,000
	SM (with height increase)	UL	UL	24,000	16,000	24,000	16,000	61,500	41,000	25,625	20,500	12,000	7,000

General approach with exceptions.



Mass Timber Used as a Fire Barrier

When used as a fire barrier or horizontal assembly to separate occupancies, Type IV-B or Type IV-C assemblies shall:

Be separated from interior of building with approved thermal barrier

Minimum of ½ inch gypsum board or

Material that is tested and accepted of both the Temperature Transmission Fire Test and the Integrity Fire Test of NFPA 275

Mass Timber Fire Resistance

TABLE 602

FIRE-RESISTANCE RATING REQUIREMENTS FOR EXTERIOR WALLS BASED ON FIRE SEPARATION DISTANCE^{a, d, g}

FIRE SEPARATION DISTANCE = X (feet)	TYPE OF CONSTRUCTION	OCCUPANCY GROUP H ^a , L	OCCUPANCY GROUP F-1, M, S-1 ^f	OCCUPANCY GROUP A, B, E, F-2, I, R ^f , S-2, U ^h
$X < 5^b$	All	3	2	1
$5 \leq X < 10$	IA, <u>IVA</u>	3	2	1
	Others	2	1	1
$10 \leq X < 30$	IA, IB, <u>IVA, IVB</u>	2	1	1 ^c
	IIB, VB	1	0	0
	Others	1	1	1 ^c
$X \geq 30$	All	0	0	0

- Type IV A, B and C added
- Exterior Wall FSD



703.9 Sealing of adjacent mass timber elements.
In buildings of Type IVA, IVB, and IVC construction, sealant or adhesive shall be provided to resist the passage of air in the following locations:

1. At abutting edges and intersections of mass timber building elements required to be fire resistance-rated
2. At abutting intersections of mass timber building elements and building elements of other materials where both are required to be fire resistance-rated.

Sealants shall meet the requirements of ASTM C920. Adhesives shall meet the requirements of ASTM D3498.

Exception: Sealants or adhesives need not be provided where they are not a required component of a tested fire resistance-rated assembly.

TABLE 1705.5.3
REQUIRED SPECIAL INSPECTIONS OF MASS
TIMBER CONSTRUCTION



Type	<u>Continuous Special Inspection</u>	<u>Periodic Special Inspection</u>
1. <u>Inspection of anchorage and connections of mass timber construction to timber deep foundation systems.</u>		X
1. <u>Inspect erection of mass timber construction</u>		X
1. <u>Inspection of connections where installation methods are required to meet design loads</u>		
<u>3.1 Threaded fasteners</u>		
<u>3.1.1 Verify use of proper installation equipment</u>		X
<u>3.1.2 Verify use of pre-drilled holes where required</u>		X
<u>3.1.3 Inspect screws, including diameter, length, head type, spacing, installation angle, and depth</u>		X
<u>3.2 Adhesive anchors installed in horizontal or upwardly inclined orientation to resist sustained tension loads</u>	X	
<u>3.3 Adhesive anchors not defined in 3.2</u>		X
<u>3.4 Bolted connections</u>		X
<u>3.5 Concealed connections</u>		X

Energy Storage Systems (ESS)

- Changes in both the CBC and CRC!
- Definition: **Energy Storage System (ESS)**. One or more devices, assembled together, capable of storing energy in order to supply electrical energy at a future time.
- **Energy Storage Management Systems**. An electronic system that protects stationary energy storage batteries systems from operating outside their safe operating parameters, and ~~generates an alarm and trouble signal for off normal conditions~~ disconnects electrical power to the ESS or places it in a safe condition if potentially hazardous temperatures or other conditions are detected.

Energy Storage Systems (ESS)

Table 509
Incidental Uses

Room or Area	Separation and/or Protection
Stationary storage battery systems having an energy capacity greater than the threshold quantity specified in Table 1206.2 of the California Fire Code	1 hour in Group B, F, M, S and U occupancies; 2 hours in Group A, E, I and R occupancies

Energy Storage Systems (ESS)

- CFC Chapter 12 contains the bulk of the criteria.
- Addresses indoor, outdoor and mobile situations.
- Rated enclosures including exterior walls.
- Group F-1 Occupancies in dedicated use buildings.
- **[F] 907.2.22 ~~Battery rooms~~ Energy Storage Systems**. An automatic smoke detection system or radiant-energy detection system shall be installed in rooms, walk-in units and areas containing stationary energy storage ~~battery~~ systems as required in Section 1206.2 of this code.

Energy Storage Systems (ESS)

- Moderate-hazard factory industrial
 - Group F-1 Occupancy
- Addresses indoor, outdoor and mobile situations.
- Rated enclosures including exterior walls. Fire protection-rated glazing is not allowed in fire barriers enclosing ESS.
- **[F] 907.2.22 Battery rooms *Energy Storage Systems*.** An automatic smoke detection system or radiant-energy detection system shall be installed in rooms, walk-in units and areas containing stationary energy storage battery systems as required in Section 1206.2 of this code.

Energy Storage Systems (ESS)

CFC 1206.1.2 Permits. Permits shall be obtained for ESS as follows:

Construction permits shall be obtained for stationary ESS installations and for mobile ESS charging and storage installations covered by 1206.10.1. Permits shall be obtained in accordance with Sections 105.7.2.

Operational permits shall be obtained for stationary ESS installations and for mobile ESS deployment operations covered by Section 1206.10.3. Permits shall be obtained in accordance with Sections 105.6.52.

Energy Storage Systems (ESS)

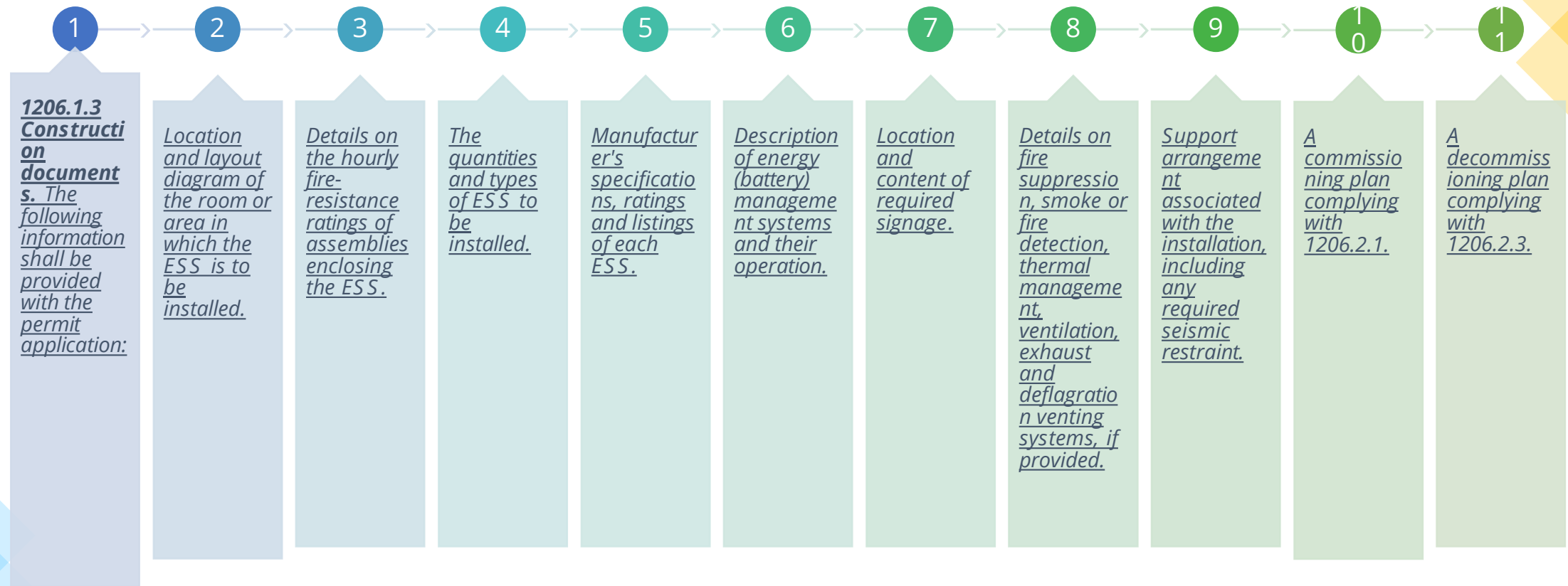

Energy Storage Systems (ESS)

- Even Mobile ESS criteria
- **CFC 1205.14 Group R-3 and R-4 Fuel Cell Vehicle ESS Use.** *The temporary use of the dwelling unit owner or occupant's fuel cell powered electric vehicle to power a Group R-3 or R-4 dwelling while parked in an attached or detached garage or outside shall comply with the vehicle manufacturer's instructions and NFPA 70.*

Mechanical Access Parking Garages (CBC only)

- Definition: Mechanical-access Enclosed Parking Garage An enclosed parking garage which employs parking machines, lifts, elevators or other mechanical devices for vehicle moving from and to street level and in which public occupancy in the garage is prohibited in all areas except the vehicle access bay.



Mechanical Access Parking Garages

Separation. Mechanical-access enclosed parking garages shall be separated from other occupancies and accessory uses by not less than 2-hour fire barrier separations or 2-hour horizontal assemblies or both.

Mechanical Access Parking Garages

A mechanical smoke removal system is required in the area of the mechanical-access enclosed parking garage.

An automatic sprinkler system is required throughout buildings that are used for mechanical-access enclosed parking garages. Also, the area of mechanical-access parking shall have specially engineered automatic sprinkler system (CBC Section 903.2.10.2)

Mechanical Access Parking Garages

Fire control equipment room accessed by an exterior fire access door required and consist of the following:

- The size is a minimum of 50 sq ft and the location approved by the Fire Code Official.
- Fire alarm control unit
- Mechanical ventilation controls and
- Emergency shut down switch (clearly identified)
 - It shall be manually activated for use by emergency personnel and in a location approved by the Fire Code Official

Fire Dept access doors per CFC Section 3203.7

Puzzle Room and Special Amusement Areas

Definition: **Puzzle Room** A puzzle room is a type of special amusement area in which occupants are encouraged to solve a challenge to escape from a room or series of rooms.



Puzzle Room and Special Amusement Areas

Definition: **Special Amusement Building Area.** A special amusement building area is any temporary or permanent building or portion thereof that is occupied for amusement, entertainment or educational purposes and is arranged in a manner that:

1. Makes the means of egress path that is not readily apparent due to visual or audio distractions.
2. Intentionally confounds identification of the means of egress path.
3. Otherwise makes the means of egress path not readily available because of the nature of the attraction or mode of conveyance through the building or structure.

*Requires the installation of a permanent or temporary automatic sprinkler system, fire alarm system, and EVACS!
Sprinkler exemption for temporary Special Amusement Areas less than 1,000 sf and travel distance less than 50 ft.
Alternate exiting systems can be approved by the Fire Official.*



Definition of Accessory Dwelling Unit (ADU) Both CBC and CRC changes!

- ACCESSORY DWELLING UNIT. [HCD 1 & HCD 2] An attached or detached residential dwelling unit that provides complete independent living facilities for one or more persons and is located on a lot with a proposed or existing primary residence. Accessory dwelling units shall include permanent provisions for living, sleeping, eating, cooking, and sanitation on the same parcel as the single-family or multifamily dwelling is or will be situated. (See Government Code Section 65852.2)



Wildland Urban Interface (WUI)

Both CBC and CRC changes!

705A.1 General. Roof assemblies in the Fire Hazard Severity Zones shall be Class A rating when tested in accordance with ASTM E108 or UL790. Not only in Very High Fire Severity Zones now!



706A.3 Ventilation openings on the underside of eaves and cornices. Vents shall not be installed on the underside of eaves and cornices unless the vents are Wildland Flame and Ember Resistant (WUI) vents approved and listed by the California State Fire Marshal, or WUI vents listed to ASTM E2886, by complying with all the following requirements:

709A.1.1 Flashing. A minimum of a 6 in. (150 mm) metal flashing, applied vertically on the exterior of the wall, shall be installed at all deck-to-wall intersections.

Wildland Urban Interface (WUI)

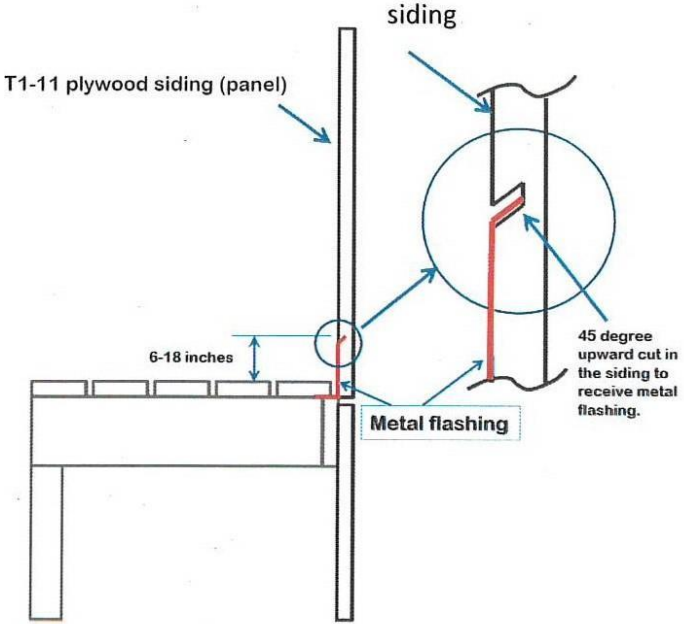
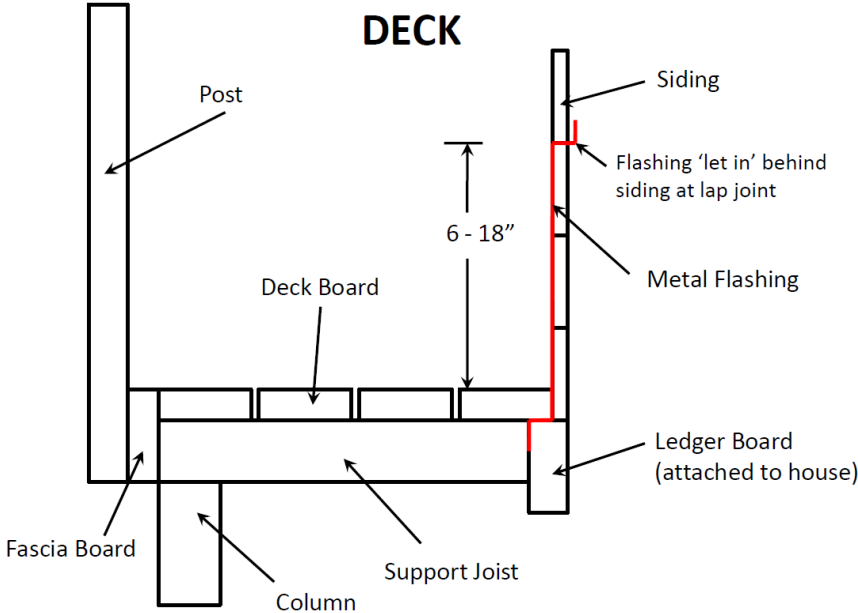
709A.1.1 Flashing. A minimum of a 6 in. (150 mm) metal flashing, applied vertically on the exterior of the wall, shall be installed at all deck-to-wall intersections.





Q & A

Paul Armstrong, P.E., CBO
parmstrong@trbplus.com

TRB+Associates
