

Marley Plumbing & Drainage Solutions Technical Manual Middle East



aliaxis-me.com



**we
make
life
flow**



02

Marley Brand introduction

Manufacturing Standards & certifications	04
Underground Standards certifications	05



33

Connection Systems

Multikwik WC Connectors Modern & Old	34
Multikwik Manifold Systems	42
Multikwik Traps	43



07

uPVC Soil & Waste System

Solvent waste uPVC	09
Solvent waste ABS	11
Push-Fi Soil uPVC	13
Solvent Soil uPVC	19
200mm Push-Fit Soil uPVC	25
uPVC Floors & Flat Roof Outlet	26
Active Drainage	28
Accessories	30

53

Underground Drainage Systems

Solid Wall Drainage Systems	54
Inspection Chambers	58
Gullies	63



67

Soil & Waste Installation Guide

Design Considerations	68
Handling, storage and safety	72
Stack design considerations	74
Joining Guide	82
Pipe Support	85
WC Connectors, Manifold & Traps Guide	88

97

Underground Installation Guide

Design Considerations	98
Pipe Laying	100
Shallow Inspections Chambers	103
Inspection Chambers	107
Manholes	109
Gully Combinations	111
Transitions to Other Systems	113
Underground Installation	117
Testing	118
Safety	119





Aliaxis & Marley Brand introduction

The Marley brand is manufactured in the UK and is globally known for its innovative solutions in the field of plumbing and drainage. Now in its 65th year, it continues to offer the finest in technical support as well as a wealth of product and installation knowledge.

Marley Plumbing & Drainage produces a complete range of Unplasticized Polyvinyl Chloride (uPVC) above ground, soil & waste and underground drainage systems as well as waste systems. It is designed for commercial, residential and largescale developments, as well as smaller projects.

Marley Plumbing & Drainage is part of the Aliaxis group of companies, internationally recognized as a major global supplier of construction products.

Marley Plumbing & Drainage not only provides products which are sustainable in their manufacture, but also those which are sustainable in their use.

The Marley range is 100% lead-free.

Manufacturing standards & certifications



British and European Standards

BS EN 1329-1: 2014

Plastics piping systems for soil and waste discharge (low and high temperature) within the building structure – PVCu.

BS EN 1451-1: 2000

Plastics piping systems for soil and waste discharge (low and high temperature) within the building structure – polypropylene.

BS EN 1519-1: 2000

Plastics piping systems for soil and waste discharge (low and high temperature) within the building structure – polyethylene.

BS 4514: 2001

Specification for PVCu soil and ventilating pipes, fittings and accessories.

BS EN 1566-1: 2000

Specification for thermoplastics waste pipe and fittings.

BS 5255: 1989

Specification for thermoplastics waste pipe and fittings.

BS EN 1455-1: 2000

Plastics piping systems for soil and waste (low and high temperature) within the building structure – ABS.

BS 5627: 1984

Specification for plastics connectors for use with horizontal outlet vitreous china WC pans.

BS EN 14680: 2015

Specification for adhesives for non-pressure thermoplastics pipe systems.

BS EN 681-1: 1996

Elastomeric seals. Material requirements for pipe joint seals used in water and drainage applications. Part 1 vulcanised rubber.

BS EN ISO 9001: 2015

Quality systems. Model for Quality Assurance in Design, Development, Production, Installation and Servicing.

BS EN ISO 14001: 2015

Environmental management systems. Requirements with guidance for use.



British Standard kitemark:
Your guarantee of quality

Underground Standards

British Standards

A wide range of components featured in this price list conform to British Standard Specifications, many items bear the British Standards Institution's Kite Mark symbol, , as indicated throughout this price list. The presence of this mark on, or in relation to, a product is an assurance that the goods have been produced under a system of supervision, control and testing, operated during manufacture and including periodical inspection of the manufacturer's works in accordance with the Certification Mark Scheme.

Agrément Certificates

Certain components and systems illustrated in this price list have been independently assessed and are the subject of certification by the British Board of Agrément. These items are indicated by the BBA symbol, , throughout this price list.

Copies of Marley Plumbing & Drainage BBA Certificates are freely available from the Company upon request or from marleypd.co.uk.

British and European Standards

BS 4660 & BS EN 1401

Thermoplastics ancillary fittings of nominal sizes 110 and 160 for below ground gravity drainage and sewerage.

BS 4962

Specification for plastic pipes and fittings for use as subsoil field drains.

BS EN 14680

Adhesives for non-pressure thermoplastic pipe systems.

BS EN 13598-2

Plastic piping systems for non-pressure underground drainage and sewerage – Unplasticized poly(vinyl chloride) (PVCU), polypropylene (PP) and polyethylene (PE) Part 2: Specifications for manholes and inspection chambers

BS EN 124

Gully tops and manhole tops for vehicular and pedestrian areas. Design requirements, type testing, marking, quality control.

BS EN 295

Vitrified clay pipes & fittings and pipe joints for drains and sewers.

BS EN 681-1

Elastomeric seals. Material requirements for pipe joint seals used in water and drainage applications.

BS EN 752

Drain & Sewer Systems outside buildings.

BS EN 1295-1

Structural design of buried pipelines under various conditions of loading. General requirements.

BS EN 1610

Construction & Testing of Drains & Sewers.

BS EN 13476-3

Plastics piping systems for non-pressure drainage and sewerage, structured wall piping systems with smooth bore and profiled external surface.

BS EN ISO 9001: 2008

Quality management systems.

BS EN ISO 14001: 2004

Environmental management systems requirements with guidance for use.

BBA 11/H172

Quantum Highway Drainage System. 375-600mm pipes and couplings.

BBA 88/1977

Marley Underground Drainage System.

BBA 09/H146

Quantum Highway PVCu Twinwall Drainage System.

BBA 94/2985

Marley Quantum Sewer PVCu Twinwall Underground Drainage and Sewerage System.

BBA 98/3486

Marley Quantum Highway PVCu Twinwall Surface Water Drainage System.

WIS 4-08-01

Bedding and sidefill materials for buried pipelines.

Accreditations



Certificate No. 88/1977
94/2985
98/3486
09/H146
11/H172

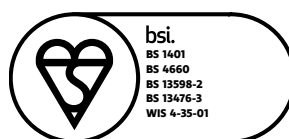

bsi.
BS 1401
BS 4660
BS 13598-2
BS 13476-3
WIS 4-35-01



FM 30637

EMS 96207





uPVC Soil & Waste Systems

Marley Plumbing & Drainage offers a comprehensive range of soil and waste systems for a complete solution for our customers' needs.

Manufactured to UK and European standards, our range of uPVC pipes and fittings covers a wide range of sizes and is designed for use on low-rise, midrise and high-rise projects.

Marley Soil & Waste systems are manufactured with both solvent welding sockets and Push Fit socket to satisfy the various requirements of projects, designers and installers.

Key Product Information

82mm, 110mm, 160mm and 200mm Soil sizes
32mm, 40mm and 50mm Waste sizes

Typical Application

82mm, 110mm and 160mm Soil sizes
32mm, 40mm and 50mm Waste sizes

Features & Benefits

- Push-fit or solvent weld jointing
- Light weight
- Easy to handle on site
- Quick and easy to install, saving time and money
- Provides quick and hygienic removal of sanitary waste water
- All collar bosses are individually pressure tested to ensure joint integrity
- Hole saw locator on all bosses for ease of installation

uPVC Soil & Waste Systems

The uPVC Soil System is available with push-fit and solvent weld options incorporating socketed and plain ended pipe. 110 and 160mm pipe support components have been designed specifically to support horizontal or vertical suspended uPVC pipework.

The Waste System is available in solvent weld options in uPVC (white & grey) suitable for internal and external applications and ABS pipes and fittings (white & grey) lightweight and cost effective for internal installation, easy to cut, joint and install.



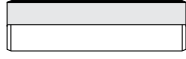

Pipe

Size mm	Code	Length	Colour	Qty
32	KP104E	4m	W B	10
40	KP204E	4m	W B	10
50	KP304E	4m	W B	5

Double spigot

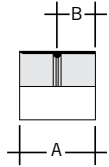

Straight couplings

Size mm	Code	A	B	Colour	Qty
32	KSC1	46	20	W B	60
40	KSC2	53	24	W B	30
50	KSC3	66	28	W B	30

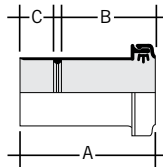

Size mm	Code	A	B	C	Colour	Qty
32	KEC1	86	61	20	W	10
40	KEC2	90	64	23	W	10
50	KEC3	82	50	30	W	10

Expansion/adaptor

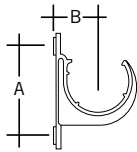

Pipe clips

Size mm	Code	A	B	Colour	Qty
32	KF1	57	30	W B G	100
40	KF2	62	30	W B G	100
50	KF3	77	41	W B G	80

Open PVCu

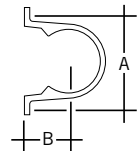

Size mm	Code	A	B	Colour	Qty
32	WC3	76	30	W B	100
40	WC4	82	30	W B	100
50	WC5	100	38	W	80

Saddle

Bends

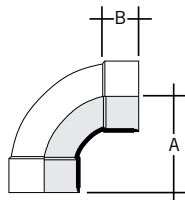

Size mm	Code	Angle	A	B	Colour	Qty
32	KB1	88½°	57	18	W B	50
40	KB2	88½°	62	21	W B	30
50	KB3	88½°	78	28	W B	10

Solvent sockets

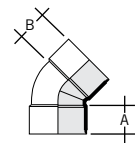

Size mm	Code	Angle	A	B	Colour	Qty
32	KB12	45°	29	18	W B	10
40	KB22	45°	33	21	W B	20
50	KB32	45°	42	28	W B	20

Solvent sockets

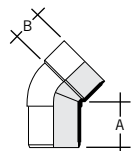

Size mm	Code	Angle	A	w	Colour	Qty
32	KBA12	45°	24	23	W	40
40	KBA22	45°	35	26	W	20
50	KBA32	45°	39	30	W B G	20

Solvent socket/spigot

PVCc Solvent weld pipe is manufactured to BS EN 1329
uPVC Solvent weld fittings are manufactured to BS 5255

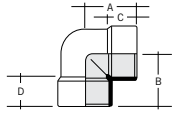

Bends

Size mm	Code	Angle	A	B	C	D	Colour	Qty
40	KBK25	90°	48	48	23	23	W B	20
50	KBK35	90°	59	50	20	28	W	10

Knuckle bend/boss adaptor, which can solvent weld over a boss upstand

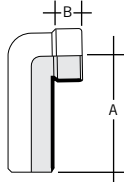

Size mm	Code	Angle	A	B	Colour	Qty
32	KBS1	87½°	92	18	W	20
40	KBS2	87½°	92	23	W	20

Solvent socket/spigot

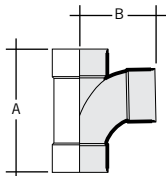

Tees

Size mm	Code	Angle	A	B	Colour	Qty
32	KT1	88½°	92	57	W B	30
40	KT2	88½°	106	62	W B	20
50	KT3	88½°	135	78	W B	10

Solvent sockets

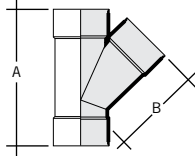

Size mm	Code	Angle	A	B	Colour	Qty
40	KT21	45°	117	78	W	20
50	KT31	45°	149	100	W	10

Solvent sockets

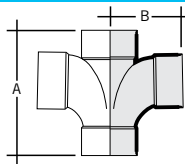

Cross Tee

Size mm	Code	Angle	A	B	Colour	Qty
40	KXT21	88½°	106	62	W	10
50	KXT31	88½°	140	87	W	10

Solvent sockets

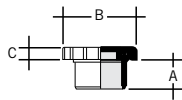

Access plug

Size mm	Code	A	B	C	Colour	Qty
32	KAP1	22	53	8	W B	10
40	KAP2	25	57	8	W B	10
50	KAP3	33	71	8	W B	10

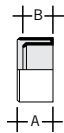

Socket reducer

Size mm	Code	A	B	Colour	Qty
32-21.5	KR175	22	20	W	100
40-32	KR210	28	22	W B	80
50-32	KR310	32	28	W	40
50-40	KR320	32	28	W B	40

Solvent spigot/socket

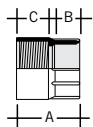

Iron adaptors

Female

Size mm	Code	A	B	C	Colour	Qty
32	KFA1	50	25	20	W	10
40	KFA2	53	25	24	W	10
50	KFA3	60	25	28	W	10

Solvent socket/BSP thread

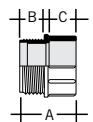

Male

Size mm	Code	A	B	C	Colour	Qty
32	KMA1	44	20	20	W	50
40	KMA2	47	20	24	W	40
50	KMA3	53	20	28	W	40

Solvent socket/BSP thread

Pipe

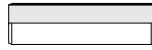

Size mm	Code	Length	Colour	Qty
32	WAP33	3m	W B G	♥ 10
40	WAP43	3m	W B G	♥ 10
50	WAP53	3m	W B G	♥ 5

Straight couplings

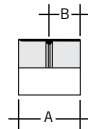

Size mm	Code	A	B	Colour	Qty
32	WAC3	40	20	W B G	♥ 40
40	WAC4	46	23	W B G	♥ 30
50	WAC5	63	30	W B G	♥ 30

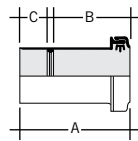

32	WAC31	86	61	20	W	♥ 10
40	WAC41	90	64	23	W	♥ 10
50	KEC3*	82	50	30	W	♥ 10

Expansion/copper adaptor

Pipe clips

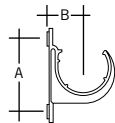

Size mm	Code	A	B	Colour	Qty
32	KF1	57	30	W B G	♥ 100
40	KF2	62	30	W B G	♥ 100
50	KF3	77	41	W B G	♥ 80

Open PCVu

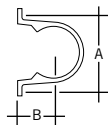

Size mm	Code	A	B	Colour	Qty
32	WC3	76	30	W B G	♥ 100
40	WC4	82	30	W B G	♥ 100
50	WC5	100	38	W	♥ 80

Saddle

Bends

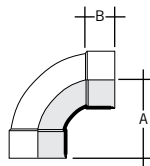

Size mm	Code	Angle	A	B	Colour	Qty
32	WAB3	88½°	55	20	W B G	♥ 50
40	WAB4	88½°	64	23	W B G	♥ 30
50	WAB5	88½°	86	30	W B G	♥ 20

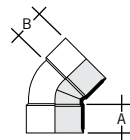

Size mm	Code	Angle	A	B	Colour	Qty
32	WAB31	45°	32	20	W B G	40
40	WAB41	45°	36	23	W B G	♥ 20
50	WAB51	45°	47	30	W B G	♥ 20

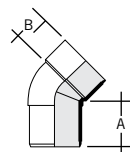

Size mm	Code	Angle	A	B	Colour	Qty
32	WAB32	45°	45	20	W	30
40	WAB42	45°	48	23	W	♥ 20

Spigot

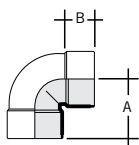

Size mm	Code	Angle	A	B	Colour	Qty
32	WAB33	90°	44	20	W B G	♥ 30
40	WAB43	90°	53	23	W B G	♥ 20

Knuckle bend

Access Plug

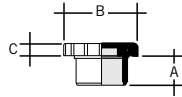

Size mm	Code	A	B	C	Colour	Qty
32	WAA3	22	53	8	W B G	10
40	WAA4	25	57	8	W B G	10
50	WAA5	33	71	8	W B G	10

Tees

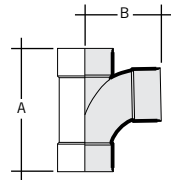

Size mm	Code	Angle	A	B	Colour	Qty
32	WAT3	88½°	90	55	W B G	30
40	WAT4	88½°	107	64	W B G	20
50	WAT5	88½°	140	86	W B G	10

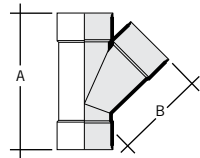

Size mm	Code	Angle	A	B	Colour	Qty
32	WAT31	45°	102	65	W	20
40	WAT41	45°	117	79	W	20
50	WAT51	45°	150	100	W	10

Cross Tee

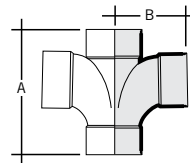

Size mm	Code	Angle	A	B	Colour	Qty
40	WAT42	88½°	106	65	W	10
50	WAT52	88½°	140	88	W	10

Socket Reducer

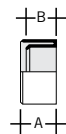

Size mm	Code	A	B	Colour	Qty
40-32	WAR43	26	20	W B G	80
50-32	WAR53	31	20	W B G	40
50-40	WAR54	31	23	W B G	40

Iron Adaptors

Female

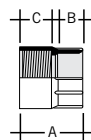

Size mm	Code	A	B	C	Colour	Qty
32	WAF3	50	25	25	W	10
40	WAF4	53	25	24	W	10
50	WAF5	60	25	28	W	10

Male

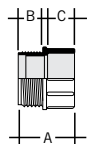

Size mm	Code	A	B	C	Colour	Qty
32	WAM3	44	20	20	W	50
40	WAM4	47	20	24	W	40
50	WAM5	53	20	28	W	40

Cap and Lining

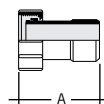

Size mm	Code	A	Colour	Qty
32	WAM31	58	W	10

Pipe

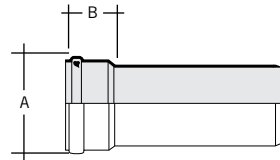

Size mm	Code	Length	A	B	Colour	Qty
82	SP303	3m	100	76	B G	♥ 156
82	SP304	4m	100	76	G	♥ 156
110MM CO-EX SOIL						
110	SP4025	2.5m	128	70	B G	♥ 100
110	SP403	3m	128	70	W B G	♥ 2
110	SP404	4m	128	70	G	♥ 100
160	SP603	3m	182	107	G	♥ 46
160	SP604	4m	182	107	G	♥ 46

Push-fit socket

Straight Couplings

Loose pipe socket

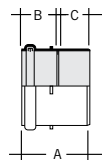

Size mm	Code	A	B	C	Colour	Qty
82	SE300	103	50	48	B G	♥ 30
110	SE400	109	61	48	W B G	♥ 8
160	SE600	190	107	77	G	♥ 4

Double ring seal slip coupling

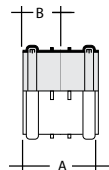

Size mm	Code	A	B	Colour	Qty
82	SE305	104	49	B G	♥ 30
110	SE405	128	64	B G	♥ 8
160	SE605	170	83	G	♥ 4

Triple socket

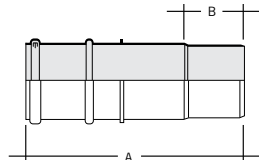

Size mm	Code	A	B	Colour	Qty
110	SE402	311	82	G	♥ 4

Short Radius Bends

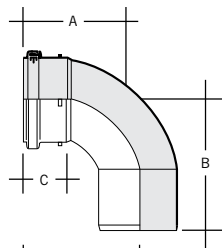

Size mm	Code	Angle	A	B	C	Colour	Qty
82	SB31	87½°	138	115	49	B G	♥ 20
110	SB41	87½°	158	157	70	W B G	♥ 4
160	SFB61	87½°	242	232	88	G	♥ 1

Push-fit socket/spigot

Size mm	Code	Angle	A	B	C	Colour	Qty
82	SB35	45°	76	73	49	B G	♥ 20
110	SB45	45°	84	89	62	W B G	♥ 4
160	SFB65	45°	120	118	85	G	♥ 2

Push-fit socket/spigot

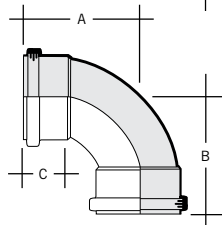

Size mm	Code	Angle	A	B	C	Colour	Qty
110	SB411	88½°	135	145	60	B G	♥ 4

Double push-fit socket

To BS 4514 and / or BS EN 1329 'B' as appropriate

Adjustable Bends

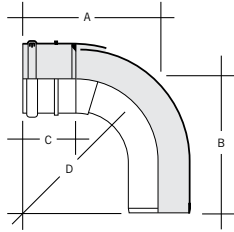

Size mm	Code	Angle	A	B	C	Colour	Qty
82	SB37	11-87½°	195	187	49	B G	10

Push-fit socket/spigot



Size mm	Code	Angle	A	B	C	Colour	Qty
110	SB46	5-14°	125	135	82	G	4

Push-fit socket/spigot

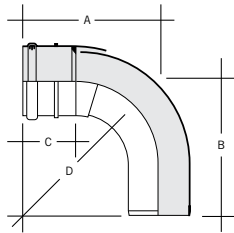

Size mm	Code	Angle	A	B	C	D	Colour	Qty
110	SB47	21-90°	189	187	90	127	B G	4

Push-fit socket/spigot



Size mm	Code	Angle	A	B	C	D	Colour	Qty
160	SB67	31-90°	285	275	96	184	G	2

Push-fit socket/spigot

Offset Bends

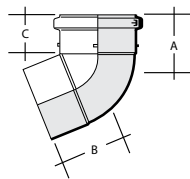

Size mm	Code	Angle	A	B	C	Colour	Qty
110	SNE405	67½°	94	91	60	W B G	4

Push-fit solvent socket

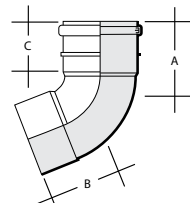

Size mm	Code	Angle	A	B	C	Colour	Qty
82	SNE300	67½°	98	86	57	B G	30

Size mm	Code	Angle	A	B	C	Colour	Qty
160	SNE600	67½°	178	182	88	G	140

Push-fit solvent socket

Equal Branches

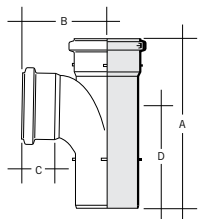

Size mm	Code	Angle	A	B	C	D	Colour	Qty
110	SY401	87½°	299	150	60	175	W B G	4

Size mm	Code	Angle	A	B	C	D	Colour	Qty
160	SY601	87½°	438	245	96	260	G	2

Push-fit sockets/spigot

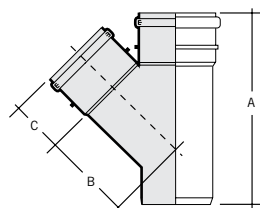

Size mm	Code	Angle	A	B	C	Colour	Qty
82	SY36	45°	229	130	55	G	10

Size mm	Code	Angle	A	B	C	Colour	Qty
110	SY460	45°	285	198	62	B G	4

Size mm	Code	Angle	A	B	C	Colour	Qty
160	SY63	45°	400	200	90	G	2

Push-fit sockets/spigot

CAD drawing available to download from marleypd.co.uk

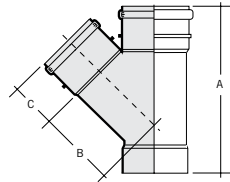

Equal Branches

Size mm	Code	Angle	A	B	C	Colour	Qty
110	SY466	45°	282	198	62	B G	4

Push-fit sockets/solvent socket

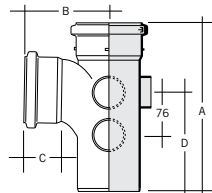

Five Boss Branches

Size mm	Code	Angle	A	B	C	D	Colour	Qty
110	SYS405	87½°	287	143	60	175	W B G	4

Push-fit sockets/spigot

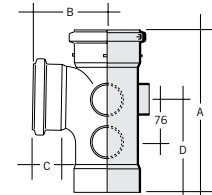

Size mm	Code	Angle	A	B	C	D	Colour	Qty
110	SYS415	87½°	280	143	60	168	B G	4

Push-fit sockets/spigot

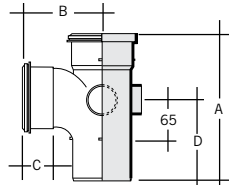

Three Boss Branch

Size mm	Code	Angle	A	B	C	D	Colour	Qty
82	SY33F	87½°	212	122	52	121	B G	10

Push-fit sockets/spigot

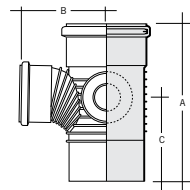

Unequal Branches

Size mm	Code	Angle	A	B	C	Colour	Qty
160x110	SY64	87½°	337	175	175	G	2

Push-fit sockets/spigot. 2 boss/access upstands

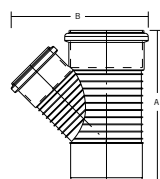

Unequal Branches

Size mm	Code	Angle	A	B	Colour	Qty
160x110	SY66	45°	335	306	G	2

Push-fit sockets/spigot

To BS 4514 and / or BS EN 1329 'B' as appropriate

Push-Fit Soil uPVC

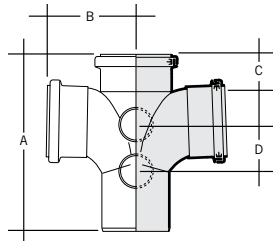

Double Branch

Size mm	Code	Angle	A	B	C	D	Colour	Qty
110	SY404	87½°	288	141	54	76	G	4

Push-fit sockets/spigot. 2 boss/access upstands

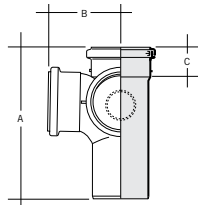

Corner Branch

Size mm	Code	Angle	A	B	C	D	Colour	Qty
110	SY419°	87½°	287	143	60	175	G	4

Push-fit sockets/spigot. 1 boss upstand

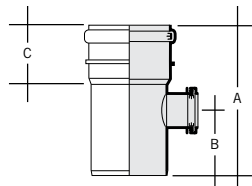

Boss Pipes

Size mm	Code	Angle	A	B	C	Colour	Qty
110	SW41	87½°	204	86	82	W B G	4

Push-fit socket/spigot. 1 40mm boss connection



Size mm	Code	Angle	A	B	C	Colour	Qty
110	SW415	87½°	204	86	82	B G	4

Push-fit socket/spigot. 1 32mm boss connection

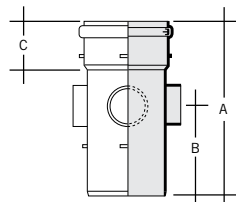

Boss Pipes

Size mm	Code	Angle	A	B	C	Colour	Qty
82	SW30	90°	202	101	49	B G	15

Push-fit socket/spigot. 3 boss upstands, 1 drilled



Size mm	Code	Angle	A	B	C	Colour	Qty
110	SW40	90°	244	123	70	W B G	4

Push-fit socket/spigot. 4 boss upstands

CAD drawing available to download from marleypd.co.uk

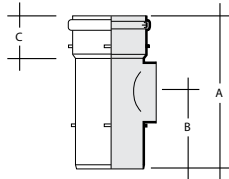

Access pipes

Size mm	Code	A	B	C	Colour	Qty
82	SF31	205	101	52	B G	15

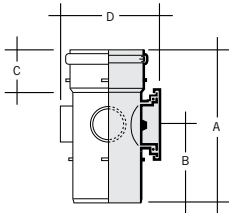

Size mm	Code	A	B	C	D	Colour	Qty
110	SF41	244	123	70	152	B G	4

Socket/spigot

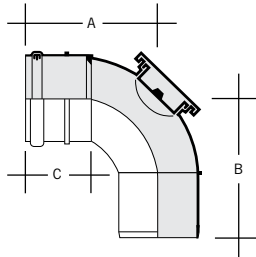

Rear Access Bends

Size mm	Code	Angle	A	B	C	Colour	Qty
110	SB42	87½°	138	146	55	B G	4

Push-fit socket/spigot



Adjustable 64° – 87½°

Size mm	Code	A	B	C	Colour	Qty
82	SB38	124	127	57	B G	1

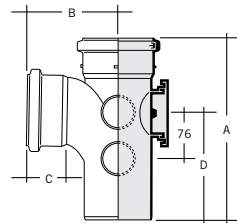

Rear Access Branches

Size mm	Code	Angle	A	B	C	D	Colour	Qty
110	SY402	87½°	287	143	60	175	B G	4

2 boss upstands

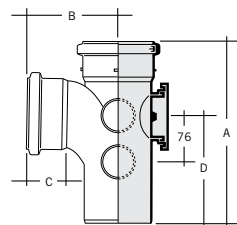

Size mm	Code	Angle	A	B	C	D	Colour	Qty
82	SY34F	87½°	212	121	52	101	B G	6

Fixed

To BS 4514 and / or BS EN 1329 'B' as appropriate

Boss Connector

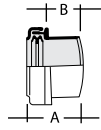

Size mm	Code	Angle	A	B	Colour	Qty
32	SA411	87½°	43	21	W B G	50
40	SA421	87½°	43	21	W B G	40
50	SA420	87½°	66	45	B G	40

Solvent weld with push-fit seal

Level invert Reducers

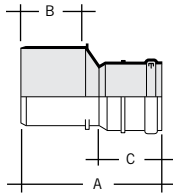

Size mm	Code	A	B	C	Colour	Qty
110x82	SRM304	192	78	82	B G	20

Spigot/socket

Size mm	Code	A	B	C	Colour	Qty
160x110	SRM604	219	90	82	G	4

Spigot/socket

Concentric Reducer

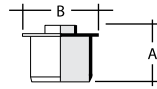

Size mm	Code	A	B	Colour	Qty
110-50	SE41	105	135	B G	18

Spigot to boss upstand

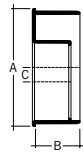

Size mm	Code	A	B	C	Colour	Qty
160	SRS604	168	68	20	G	6

Spigot to boss upstand

Adaptor

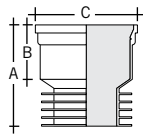

Size mm	Code	A	B	C	Colour	Qty
110	SA42	130	65	130	B	40

Soil to drain adaptor

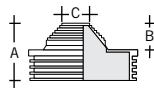

Size mm	Code	A	B	C	Colour	Qty
110	SA110	58	25	34	B	10

Waste to drain adaptor

PIPE

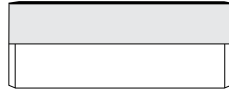
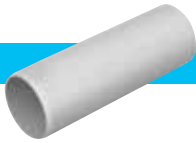

110MM CO-EX SOIL

Size mm	Code	Length	Colour	Qty
110	SL403	3m	W B G	♥ 100
110	SL404	4m	G	♥ 100
160	SL603	3m	G	46
160	SL604	4m	G	46

Double spigot

Straight Couplings

Loose pipe socket

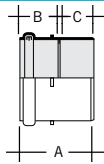
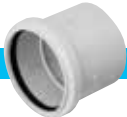

Size mm	Code	A	B	C	Colour	Qty
82	SE300	103	50	48	B G	♥ 30
110	SE400	109	61	48	W B G	♥ 8
160	SE600	190	107	77	G	♥ 4

Double solvent socket

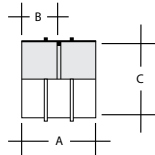

Size mm	Code	A	B	C	Colour	Qty
82	SES301	93	44	82	G	♥ 50
110	SES401	102	50	124	B G	♥ 8
160	SES601	174	64	128	G	4

Expansion Coupling

Solvent socket ring seal adaptor

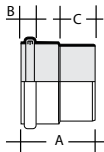

Size mm	Code	A	B	C	Colour	Qty
110	SE409	105	20	52	B G	8

To accommodate thermal movement in both vertical and horizontal solvent pipework

Size mm	Code	A	B	C	Colour	Qty
160	MZH				G	12
200	MBH				G	12

Products offered by Nicoll

Short Radius Bends

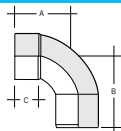

Size mm	Code	Angle	A	B	C	Colour	Qty
110	SBS41	87½°	162	168	50	G	♥ 4

Solvent socket/spigot

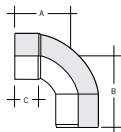

Size mm	Code	Angle	A	B	C	Colour	Qty
82	SBS31EXP	87½°	91	95	45	G	
110	SBS42	87½°	149	149	47	B G	♥ 4
160	SBS62	87½°	186	186	66	G	2

Double solvent socket

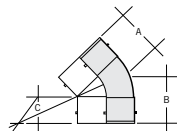

Size mm	Code	Angle	A	B	C	Colour	Qty
82	SBS35EXP	45°	67	82	45	G	
110	SBS45	45°	76	76	52	B G	♥ 4
160	SBS65	45°	98	98	66	G	2

Double solvent socket

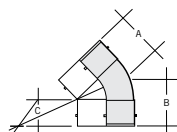

Size mm	Code	Angle	A	B	C	Colour	Qty
110	SBS415	45°	76	89	52	B G	4

Solvent socket/spigot

Long Radius Bend

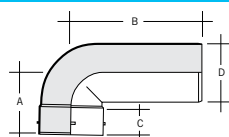

Size mm	Code	Angle	A	B	C	D	Colour	Qty
110	SBS40	87½°	114	240	48	110	W B G	♥ 4

Solvent socket/spigot

To BS 4514 and / or BS EN 1329 'B' as appropriate



Offset Bends

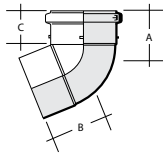

Size mm	Code	Angle	A	B	C	Colour	Qty
110	SNE405	67½°	76	61	60	W B G	4

Push-fit solvent socket

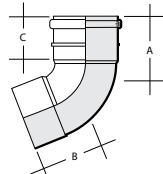

Size mm	Code	Angle	A	B	C	Colour	Qty
82	SNE300	67½°	88	48	49	B G	30
160	SNE600	67½°	178	182	96	G	140

Push-fit solvent socket.

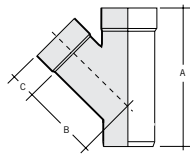

Equal Branch

Size mm	Code	Angle	A	B	C	Colour	Qty
110	SYS460	45°	277	135	55	B G	4

Solvent sockets/spigot

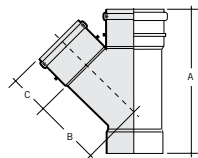

Equal Branches

Size mm	Code	Angle	A	B	C	Colour	Qty
110	SYS466	45°	282	138	60	B G	4

Push-fit sockets/solvent socket

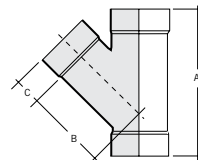

Size mm	Code	Angle	A	B	C	Colour	Qty
82	SYS366EXP	45°	216	105	45	G	
110	SYS466	45°	274	135	55	B G	4
160	SYS666	45°	362	194	66	G	4

Triple solvent sockets

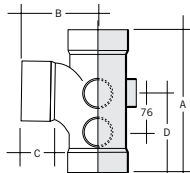

Five Boss Branch

Size mm	Code	Angle	A	B	C	D	Colour	Qty
110	SYS405	87½°	272	135	55	168	B G	4

Triple solvent socket

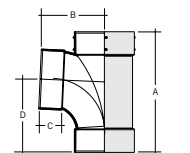

Size mm	Code	Angle	A	B	C	D	Colour	Qty
82	SYS301EXP	87½°	188	96	45		G	
160	SYS601	87½°	270	180	66	205	G	2

Triple solvent socket

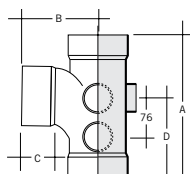

Size mm	Code	Angle	A	B	C	D	Colour	Qty
110	SY415	87½°	279	135	55	175	B G	4

Solvent socket/spigot

CAD drawing available to download from marleypd.co.uk

Unequal Branches

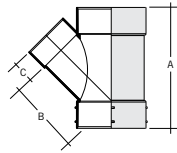

Size mm	Code	Angle	A	B	C	Colour	Qty
160	SYS644	45°	286	169	55	G	4

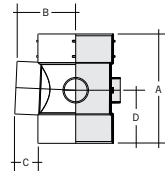

Size mm	Code	Angle	A	B	C	D	Colour	Qty
160	SYS664	87½°	234	132	52	118	G	4

Double Branch

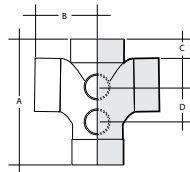

Size mm	Code	Angle	A	B	C	D	Colour	Qty
110	SYS404	87½°	274	133	45	76	G	4

All solvent sockets, 4 boss upstands

Corner Branch

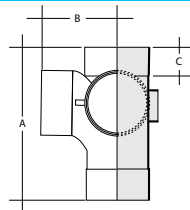

Size mm	Code	Angle	A	B	C	Colour	Qty
110	SYS411°	87½°	272	135	55	G	1

All solvent sockets. 1 boss upstand

Boss Pipes

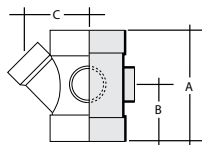

Size mm	Code	Angle	A	B	C	Colour	Qty
110	SWS4135	45°	186	93	145	G	4

All solvent sockets. Three 50mm boss upstands

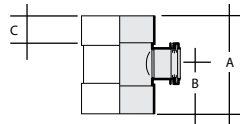

Size mm	Code	Angle	A	B	C	Colour	Qty
110x32	SWS415	87½°	170	85	52	W B G	4

Double solvent socket. One 32mm boss connection

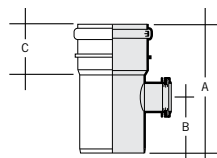

Size mm	Code	Angle	A	B	C	Colour	Qty
110x40	SWS41	87½°	170	85	52	W B G	4

Double solvent socket. One 40mm boss connection



Size mm	Code	Angle	A	B	C	Colour	Qty
110x50	SWS42	87½°	170	85	52	B G	4

Double solvent socket. One 50mm boss connection

To BS 4514 and / or BS EN 1329 'B' as appropriate

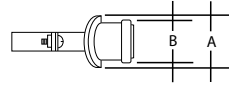

Strap-On-Boss

Size mm	Code	Angle	A	B	Required hole size	Colour	Qty
32x110	SWS4150	90°	70	55	50	B G	40
40x110	SWS410	90°	70	62	50	B G	40
50x110	SWS420	90°	86	75	63	B G	30

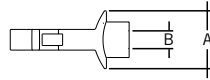

Condensate Strap-On-Boss

Size mm	Code	Angle	A	B	Colour	Qty
21.5x110	SWS4C	90°	70	21.5	G	50

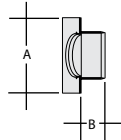

Patch Boss

Size mm	Code	A	B	Colour	Qty
32x82	SWS332	95	18	G	20
40x82	SWS340	95	23	G	20
50x82	SWS350	95	27	G	20

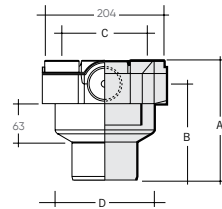

8-way Collar Boss

Size mm	Code	A	B	C	D	Colour	Qty
110	SCB41	195	157	140	164	G	1

Solvent socket/spigot

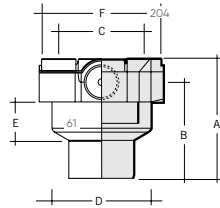

Size mm	Code	A	B	C	D	Colour	Qty
110	SCBS41	184	146	140	164	G	1

Double solvent socket tail

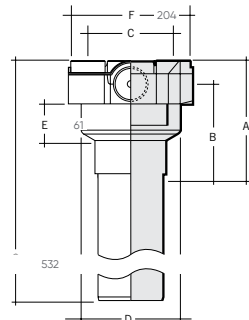

Size mm	Code	A	B	C	D	Colour	Qty
110	SCBL41	532	146	140	164	G	1

Solvent socket/spigot with 350mm spigot tail

Boss Pipes

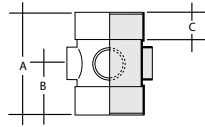

Size mm	Code	Angle	A	B	C	Colour	Qty
110	SWS40	90°	179	92	55	B G	4
160	SWS60	90°	200	100	66	G	4

Double solvent socket. 4 boss upstands, 1 drilled

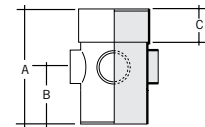

Size mm	Code	Angle	A	B	C	Colour	Qty
110	SWS405		179	92	54	B G	4

Solvent socket/spigot. 4 boss upstands, 1 drilled

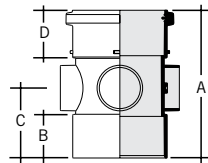

Size mm	Code	Angle	A	B	C	D	Colour	Qty
110	SWS406	90°	184	55	87	60	G	4

Push-fit/Solvent socket. 4 boss upstands.

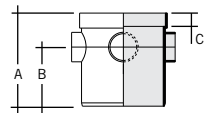

Size mm	Code	Angle	A	B	C	Colour	Qty
160	SW60	90°	335	110	96	G	4

Solvent socket/spigot.

Condensation Trap

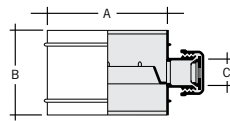

Size mm	Code	A	B	C	Colour	Qty
110	SCT4°	115	82	22	G	6

With 21.5/22mm overflow connection

Access Caps

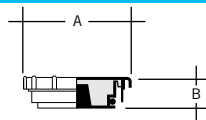

Size mm	Code	A	B	Colour	Qty
82	SE30	114	35	B G	30
110	SE40	150	37	B G	30
160	SE62	195	40	G	15

With pressure plug

Access Pipes

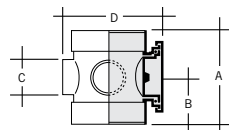

Size mm	Code	A	B	C	D	Colour	Qty
110	SFS41	150	75	56	154	W B G	4

Double solvent sockets. 3 boss upstands

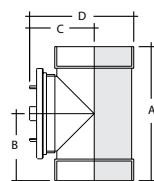

Size mm	Code	A	B	C	D	Colour	Qty
160	SF611	287	144	138	223	G	2

Double solvent sockets

Rear Access Bend

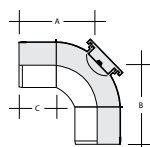

Size mm	Code	Angle	A	B	C	Colour	Qty
110	SBS420	87½°	131	128	54	B G	4

Double solvent socket

Boss Connectors



Size mm	Code	A	B	Colour	Qty
32	SA415	35	20	G	50
40	SA425	30	25	B G	50
50	SA435	58	28	G	50

Solvent weld with solvent weld joint

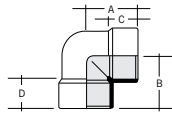

Size mm	Code	Angle	A	B	C	D	Colour	Qty
40	KBK25	90°	48	48	23	23	W B	20
50	KBK35	90°	59	50	20	28	W	10

Solvent weld

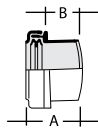

Size mm	Code	A	B	Colour	Qty
32	SA411	43	21	W B G	50
40	SA421	43	21	W B G	40
50	SA420	66	45	B G	40

Concentric Reducers

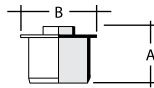

Size mm	Code	A	B	Colour	Qty
110-50	SE41	105	135	B G	18

Spigot to boss upstand

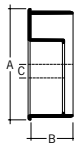

Size mm	Code	A	B	C	Colour	Qty
160-110	SRS604	168	68	20	G	6

Spigot/Socket

Eccentric Reducers

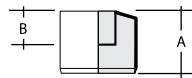

Size mm	Code	A	B	Colour	Qty
82-50	SRM30	66	35	B G	90

Spigot tail

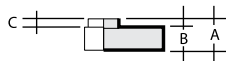

Size mm	Code	A	B	C	Colour	Qty
110-50	SRM402	48	25	19	B G	10

Solvent socket to boss upstand

Vent Terminals

Roof cowl/vent terminal

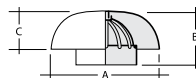

Size mm	Code	A	B	C	Colour	Qty
110	SVC1	200	98	70	W B G	10

Vent terminal

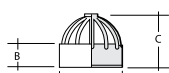

Size mm	Code	A	B	C	Colour	Qty
82	SV321	90	30	75	B G	30
110	SV42	117	34	95	W B G	60

Vent terminal

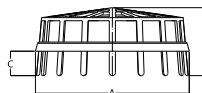

Size mm	Code	A	B	C	Colour	Qty
160	SV62°	160	71	25	G	20

Pipe

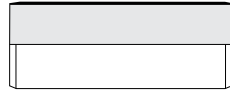
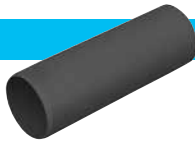

Size mm	Code	Length	Colour
200	SL806	6m	G

Double Spigot

Straight couplings

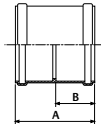

Size mm	Code	Angle	A	B	Colour
200	063204M		217	106	G

Rubber ring/Rubber ring

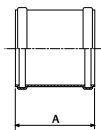

Size mm	Code	Angle	A	Colour
200	061204M	217		G

Slip coupler

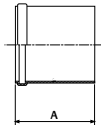

Size mm	Code	Angle	A	Colour
200	063208M	217		G

Rubber ring/Solvent cement

Short radius bends

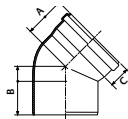

Size mm	Code	Angle	A	B	C	Colour
200	070204M	45°	148	146	84	G

Socket/Spigot

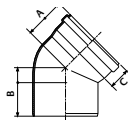

Size mm	Code	Angle	A	B	C	Colour
200	071204M	90°	207	205	85	G

Socket/Spigot

Equal branches

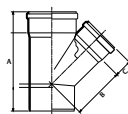

Size mm	Code	Angle	A	B	C	Colour
200	030204M	45°	482	256	81	G

Socket/Spigot

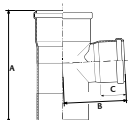

Size mm	Code	Angle	A	B	C	Colour
200	081204M	87°	410	119	86	G

Socket/Spigot

Unequal branches

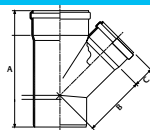

Size mm	Code	Angle	A	B	C	Colour
200 x 160	031204M	45°	432	232	74	G

Socket/Spigot

Level invert reducers

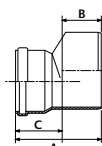

Size mm	Code	Angle	A	B	C	Colour
200 x 160	051404M		213	100	113	G

Socket/Spigot

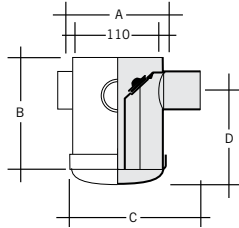

Trapped Floor Gullies

Size mm	Code	A	B	C	D	Colour	Qty
50	SFG42AS	117	164	145	116	G	8

Solvent outlet. 90mm adjustable water seal

Size mm	Code	A	B	C	D	Colour	Qty
82	SFG43AS	117	164	175	100	G	8

Solvent outlet. 75mm adjustable water seal

Stainless Steel Tile Grate and Cover

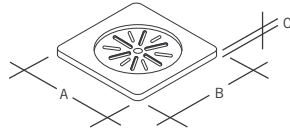

Code	A	B	C	Colour	Qty
150x150 SGG4	150	150	7	NU	40

Grade 304 stainless steel

Ancillary items

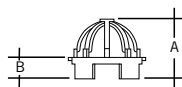

Vent Terminal

Size mm	Code	A	B	Colour	Qty
50	RV225	55	18	W B G	30

Spare Ring Seals

'T' ring



Size mm	Code	Colour	Qty
82	SR82T	B	5
110	SR110T	B	5
160	SR160T	B	5

To BS EN 681/1

Spigot Tail

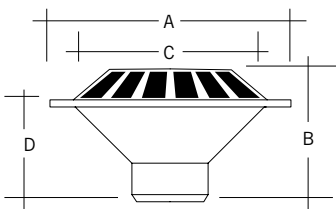

Size mm	Code	A	B	C	D	Colour	Qty
82	RV637	280	157	214	130	G	1
110	RV369	280	157	214	122	G	1
160	RV482	380	170	250	148	G	1

Balcony - Full Flat Grating, Solvent Socket Tail

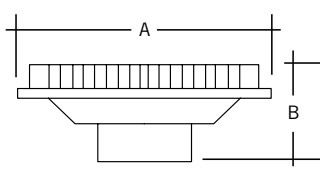

Size mm	Code	A	B	Colour	Qty
82	RV195	355	165	G	1
110	RV196	355	140	G	1

Typical installation detail

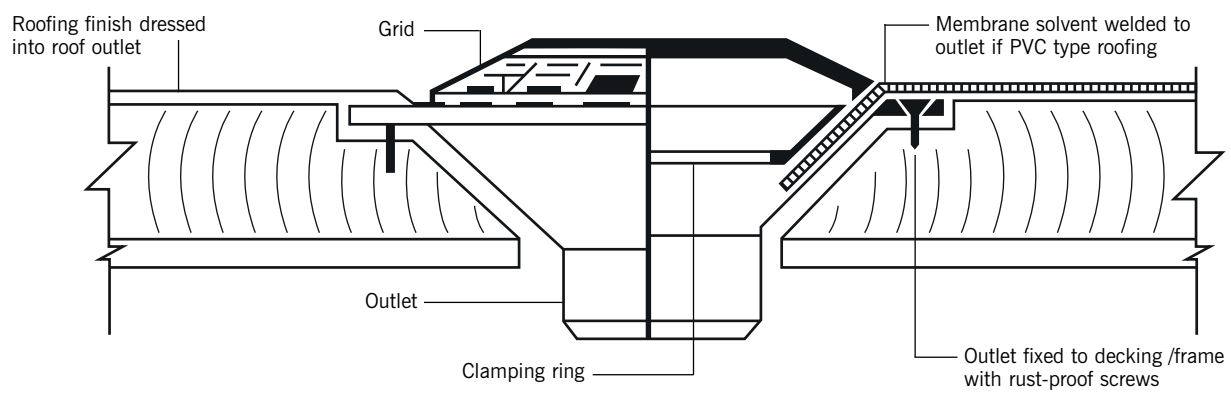

NB: It is important to prevent upthrust on the vertical rainwater pipe due to thermal movement from breaking the joint between the outlet and roof finish. Thermal movement can be accommodated by anchoring a push-fit socket with a socket bracket and allowing a 10mm expansion gap between spigot end and socket depth. A maximum of 4m between expansion joints should be allowed for.

It may be necessary to provide a warning pipe to indicate blockage on internal rainwater systems. For more details refer to BS EN 12056 - 3

Colour Key: G = Grey

Marley Studor P.A.P.A. (Positive Air Pressure Attenuator)

Size mm	Code	A	B	C	D	E	F	G	H	I	Colour	Qty
75/110	8F-STU616-WHB	200	652	104	83	89	111	50	75	106	W	1



Installation recommendations

5 - 10 floors	One unit on the base
11 - 15 floors	One unit on the base, one halfway
16 - 25 floors	One on base, one on 5th floor, one half way or remaining floors above 5th floor
26 - 50 floors	Two units in series on the base, then one unit on every fifth floor up to the 25th floor, and then one every 10th floor
51 or more	Please consult with manufacturer for further information

Temperature range	- 20°C to + 60°C - 40°F to + 150°F	Volume Capacity	
		Series assembly	(litres)
Max. pressure rating	10,000 Pa (1m/40" H ₂ O) at 0 Pa or higher	1 unit	3.785
		2 units	7.570
		3 units	11.355
		4 units	15.140

Marley Studor Maxi-Vent with connector

Size mm	Code	A	B	C	D	E	F	G	H	I	Colour	Qty
75/110	8F-STU616-WHB	200	652	104	83	89	111	50	75	106	W	1

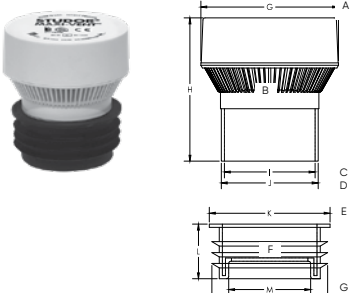

Performance parameter

Temperature range	- 40°C to + 60°C (CE) - 40°F to + 150°F (ASSE)	Air flow capacity	Branch	Stack
		Europe	32 l/s	32 l/s
Opening pressure	-70 Pa (-0.010 PSI)	AU/NZ	32 l/s / 1728 FU	32 l/s / 125 FU
Max. pressure rating tightness	10,000 Pa (1m/40" H ₂ O) at 0 Pa or higher	USA	1 to 160 DFU	72 to 500 DFU

Marley Studor Mini-Vent with connector

Size mm	Code	A	B	C	D	E	F	G	Qty
32-63	49017	70	67	47	67	31.9	33	64	1

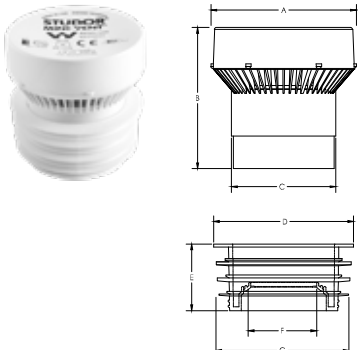

Performance parameter

Temperature range	-20°C to +60°C (CE) -40°F to +150°F (ASSE)	Air flow capacity	Branch	Stack
		Europe	7.5 l/s	7.5 l/s
Opening pressure	-70 Pa (-0.010 PSI)	AU/NZ	7.5 l/s / 94 FU	7.5 l/s / 7 FU
Max. pressure rating tightness	10,000 Pa (1m/40" H ₂ O) at 0 Pa or higher	USA	1 to 160 DFU	8 to 24 DFU

Advantages of Air Admittance Valves (AAV's) in low rise and high rise buildings

Problem

Low-rise buildings (up to 3 storey) normally have a traditional soil pipe penetrating the roof top and venting foul odours to atmosphere, which is unsightly and costly to install.

Solution

Use a Maxi-Vent to terminate the SWV pipe inside the building.



Problem

Medium-rise buildings - 4 to 12 storeys can suffer from induced siphonage of traps due to negative air pressure caused by sanitary appliances being flushed on one level affecting the traps on another level.

Solution

Use a Maxi-Vent to terminate on each branch and a Maxi-Vent on the vertical stack.



Problem

High-rise buildings - above 12 storeys, negative and positive air pressure caused by multiple appliances flushing simultaneously can influence water seal traps in bathrooms.

Solution

Use an active ventilation system to dampen positive air pressure together with Mini and Maxi-Vent AAV's.



Subject to Marley approved drawings.

Clips

Socket clip

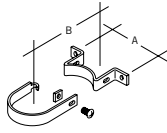

Size mm	Code	A	B	Colour	Qty
110	SC41	152	101	B G	50
160	SC61	240	121	G	50

PVC coated mild steel, includes 6x20mm nut and bolt



Barrel clip collar

Size mm	Code	Colour	Qty
1000	SC621	G	25

Converts socket clip to pipe clip (3x110mm or 2x160mm)

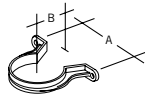

Pipe clip

Size mm	Code	A	B	Colour	Qty
82	SC35	117	70	B G	20

PVCu

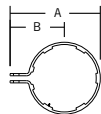

Pipe clip

Size mm	Code	A	B	Colour	Qty
82	SC35	117	70	B G	20

PVCu



Extension backplate

Code	A	B	Colour	Qty
RT200	104	45	W B G BR	50

PVCu

For use with RC251/2, RCE2 and RC32 pipe clips

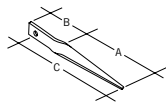

Drive-in spike

Size mm	Code	A	B	Colour	Qty
	RSS1	115	58 19	G	50

For use with drive-in spike or backplate.

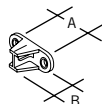

Backplate

Code	A	B	Colour	Qty
RCB300	48	31	W B G BR	100

For use with SC355

To BS 4514 and / or BS EN 1329 'B' as appropriate

Clips

Extension Bracket

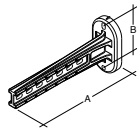

	Code	A	B	Colour	Qty
110	RT250	243	114	B G	20

Cover plate

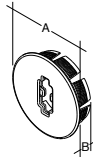

	Code	A	B	Colour	Qty
110	RT2501	111	35	B G	1

For use with RT250

Pipe clip

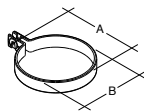

	Code	A	B	Colour	Qty
110	RPC1	137	111	B G	20

Socket clip

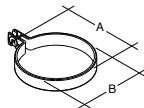

	Code	A	B	Colour	Qty
110	RSC1	141	119	B G	1

Weathering collar



Size mm	Code	A	B	C	Colour	Qty
82	SV31*	51	94	25	B	100
110	SV43	57	130	25	W B G	35

PVCu for solvent joint to pipe *Available in black rubber only.

Weathering Slates

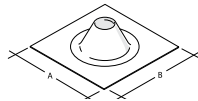
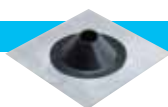

Size mm	Code	A	B	Colour	Qty
400	SAS40	400	400	G	5

Flat

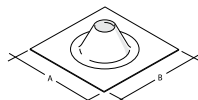
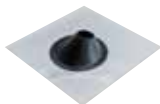

Size mm	Code	A	B	Colour	Qty
450	SAS45	450	450	G	5
610	SAS61	610	610	G	5

Inclined. Aluminium to rubber

To BS 4514 and/or BS EN 1329 'B' as appropriate. Accessories are suitable for both push-fit and solvent soil systems
 CAD drawing available to download from marleypd.co.uk





Connection Systems

- Multikwik WC connectors modern & old
- Multikwik manifold systems
- Multikwik traps

PIPE: 1: Standard 99-105mm 2: Cast Iron 88-92mm 3: Old 74-77mm 4: Copper 105-108mm

Straight

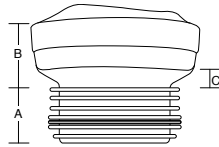

Code	Pan spigot outer diameter (mm)	Soil pipe inner diameter (mm)	Weight	A	B	C
MKS2	97 – 108	99 – 105	0.16	43	52	15

Known as the No.2 – the plumbers favourite
This connector is for new style pans only

Extended straight

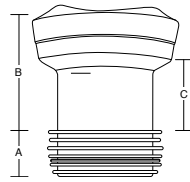

Code	Pan spigot outer diameter (mm)	Soil pipe inner diameter (mm)	Weight	A	B	C
MKS4	97 – 108	99 – 105	0.19	45	105	70

Long adjustable straight

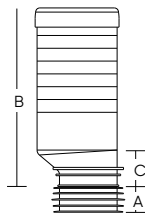

Code	Pan spigot outer diameter (mm)	Soil pipe inner diameter (mm)	Weight	A	B	C
MKLA1	97 – 108	99 – 105	0.46	40	285	255

Can be cut to suit
This connector is for new style pans only

Straight – including vent boss

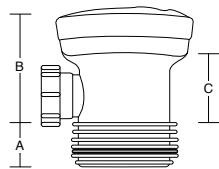

Code	Pan spigot outer diameter (mm)	Soil pipe inner diameter (mm)	Weight	A	B	C
MKSB4	97 – 108	99 – 105	0.22	42	104	70

40mm vent boss

18mm offset

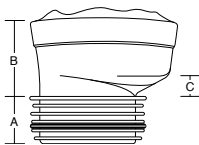

Code	Pan spigot outer diameter (mm)	Soil pipe inner diameter (mm)	Weight	A	B	C
MK02	97 – 108	99 – 105	0.17	45	70	20

40mm offset

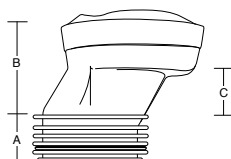

Code	Pan spigot outer diameter (mm)	Soil pipe inner diameter (mm)	Weight	A	B	C
MK04	97 – 108	99 – 105	0.19	43	85	43

PIPE: 1: Standard 99-105mm 2: Cast Iron 88-92mm 3: Old 74-77mm 4: Copper 105-108mm

Multiclik – flexible straight

Code	Pan spigot outer diameter (mm)	Soil pipe inner diameter (mm)	Weight	A	B	C
MKC2	97 – 108	99 – 105	0.37	50	170	120

Extends from 225 to 550mm
Superior quality hose retains its position whatever shape is required
Ideal when installing back to the wall, floor standing pans

Multiclik 90° Bend

Code	Pan spigot outer diameter (mm)	Soil pipe inner diameter (mm)	Weight	A	B	C
MKC2B90	97 – 108	99 – 105	0.57	50	270	110

Extends from 375 to 710mm
Superior quality hose retains its position whatever shape is required
Converts a 'P' trap into an 'S' trap with adjustment for final connection

Multiclik 90° bend including boss

Code	Pan spigot outer diameter (mm)	Soil pipe inner diameter (mm)	Weight	A	B	C
MKC2BB90	97 – 108	99 – 105	0.59	50	265	105

Extends from 405 to 740mm
Superior quality hose retains its position whatever shape is required
Converts a 'P' trap into an 'S' trap with adjustment for final connection
To be installed in a vertical position

14° Bend

Code	Pan spigot outer diameter (mm)	Soil pipe inner diameter (mm)	Weight	A	B	C
MKB114	97 – 108	99 – 105	0.19	43	80	30

45° Bend

Code	Pan spigot outer diameter (mm)	Soil pipe inner diameter (mm)	Weight	A	B	C
MKB45	97 – 108	99 – 105	0.19	43	100	60

Ideal for corner installations

104° Bend

Code	Pan spigot outer diameter (mm)	Soil pipe inner diameter (mm)	Weight	A	B	C
MKB21104	97 – 108	99 – 105	0.24	60	110	34

PIPE: 1: Standard 99-105mm 2: Cast Iron 88-92mm 3: Old 74-77mm 4: Copper 105-108mm

90° Bend

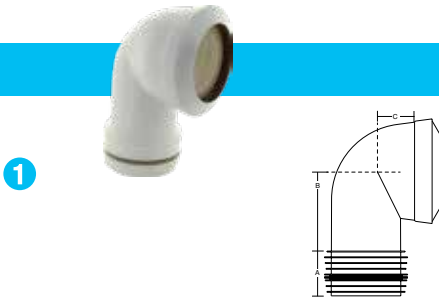

Code	Pan spigot outer diameter (mm)	Soil pipe inner diameter (mm)	Weight	A	B	C
MKBB2190	97 – 108	99 – 105	0.30	60	115	80

90° Bend – Including Vent Boss

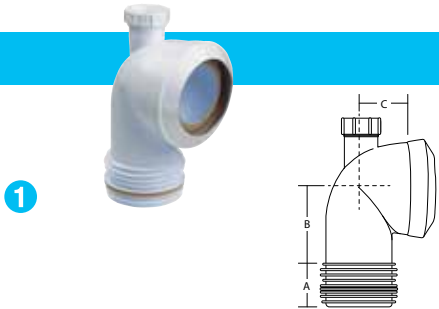

Code	Pan spigot outer diameter (mm)	Soil pipe inner diameter (mm)	Weight	A	B	C
MKBB2190	97 – 108	99 – 105	0.31	60	110	65

40mm vent boss
Must be used in a vertical position if boss is being used

90° Bend – Tall



Code	Pan spigot outer diameter (mm)	Soil pipe inner diameter (mm)	Weight	A	B	C
MKBB3190	97 – 108	99 – 105	0.36	43	200	90

90° Bend – Including Boss

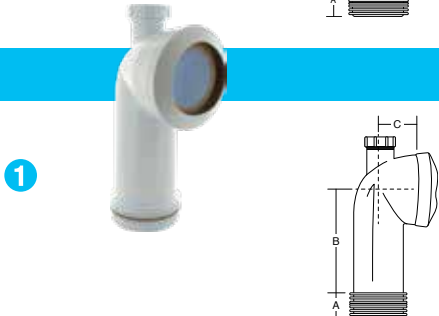

Code	Pan spigot outer diameter (mm)	Soil pipe inner diameter (mm)	Weight	A	B	C
MKBB3190	97 – 108	99 – 105	0.35	43	200	70

Includes 40mm compression boss
Must be used in a vertical position if boss is being used

90° Space Saver Bend



Code	Pan spigot outer diameter (mm)	Soil pipe inner diameter (mm)	Weight	A	B	C
MKBBAR90	97 – 108	99 – 105	0.38	34	255	91

Ideal when replacing old BS1213 'S' trap pans
Can be cut to suit both horizontally and vertically

Rigid 18mm Offset

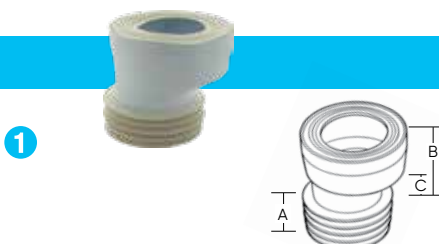

Code	Pan spigot outer diameter (mm)	Soil pipe inner diameter (mm)	Weight	A	B	C
MKRO2	97 – 108	99 – 105	0.20	35	80	35

40mm vent boss

PIPE: 1: Standard 99-105mm 2: Cast Iron 88-92mm 3: Old 74-77mm 4: Copper 105-108mm

Rigid 14° Bend

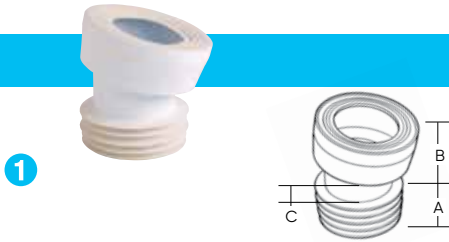

Code	Pan spigot outer diameter (mm)	Soil pipe inner diameter (mm)	Weight	A	B	C
MKRB14	97 – 108	99 – 105	0.20	40	105	40

Rigid 90° Bend

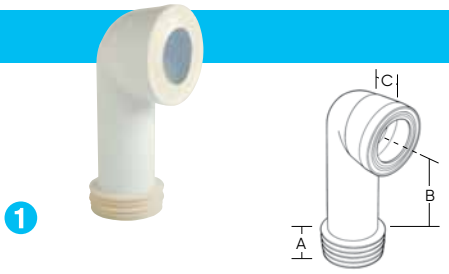

Code	Pan spigot outer diameter (mm)	Soil pipe inner diameter (mm)	Weight	A	B	C
MKRB90	97 – 108	99 – 105	0.33	37	210	50

Adjustable length: remove the fined seal and cut with a fine tooth saw

Rigid Straight

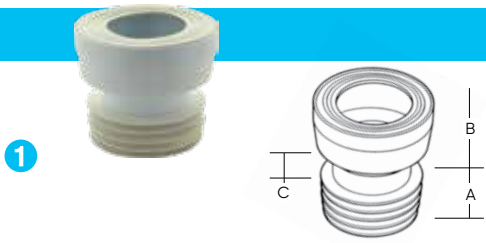

Code	Pan spigot outer diameter (mm)	Soil pipe inner diameter (mm)	Weight	A	B	C
MKRS2	97 – 108	99 – 105	0.20	37	75	30

Rigid 100mm Offset

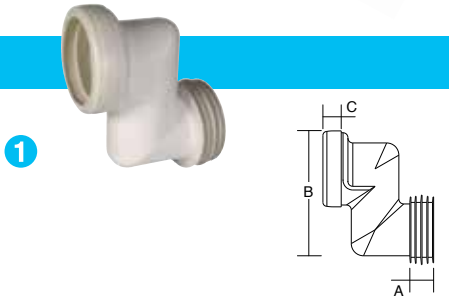

Code	Pan spigot outer diameter (mm)	Soil pipe inner diameter (mm)	Weight	A	B	C
MK0100	97 – 108	99 – 105	0.26	40	207	26

Extension length: 15mm

Extended Straight for 3½" Soil

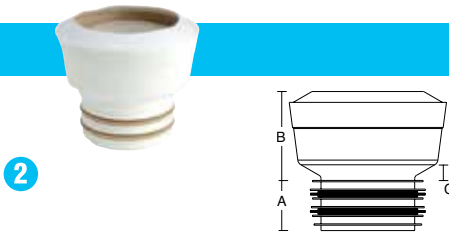

Code	Pan spigot outer diameter (mm)	Soil pipe inner diameter (mm)	Weight	A	B	C
MKS7	97 – 108	88 – 92	0.17	41	70	15

Extension length: 15mm

18mm Offset for 3½" Soil

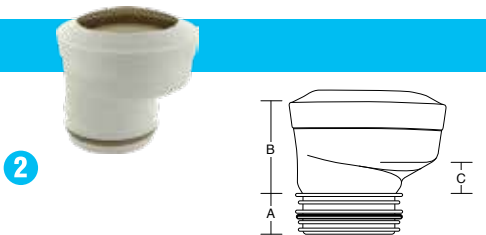

Code	Pan spigot outer diameter (mm)	Soil pipe inner diameter (mm)	Weight	A	B	C
MK07	97 – 108	88 – 92	0.15	34	77	30

PIPE: 1: Standard 99-105mm 2: Cast Iron 88-92mm 3: Old 74-77mm 4: Copper 105-108mm

18mm Offset old BS1213 Pans to oversize soil



Code	Pan spigot outer diameter (mm)	Soil pipe inner diameter (mm)	Weight	A	B	C
MK01S	97 – 108	105 – 108	0.18	45	76	20

14° Bend for Oversize Soil

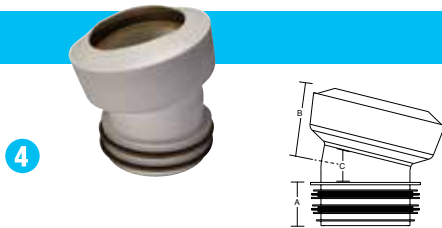

Code	Pan spigot outer diameter (mm)	Soil pipe inner diameter (mm)	Weight	A	B	C
MKB114S	97 – 108	105 – 108	0.20	43	80	35

90° Bend for Oversize Soil

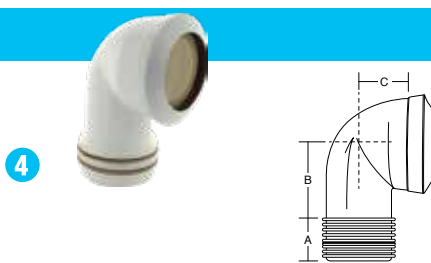

Code	Pan spigot outer diameter (mm)	Soil pipe inner diameter (mm)	Weight	A	B	C
MKB2190S	97 – 108	105 – 108	0.32	60	115	80

Straight



Code	Pan spigot outer diameter (mm)	Soil pipe inner diameter (mm)	Weight	A	B	C
MKS1	108 – 114	99 – 105	0.16	44	67	15

Known as the No.1 – the plumbers favourite
This connector is for old style pans only – for new pans use an MKS2 (see page 24)

Straight Old BS1213 Syphonic Pans

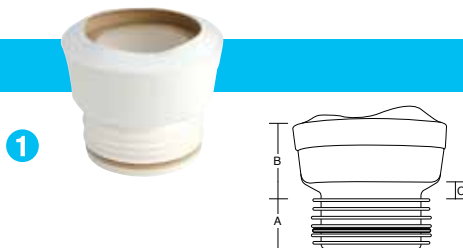

Code	Pan spigot outer diameter (mm)	Soil pipe inner diameter (mm)	Weight	A	B	C
MKS1A	108 – 114	99 – 105	0.17	40	70	15

18mm Offset old BS1213 Pans



Code	Pan spigot outer diameter (mm)	Soil pipe inner diameter (mm)	Weight	A	B	C
MK01	108 – 114	99 – 105	0.17	45	70	25

PIPE: 1: Standard 99-105mm 2: Cast Iron 88-92mm 3: Old 74-77mm 4: Copper 105-108mm

90° Tight Knuckle Bend old BS1213 Pans



Code	Pan spigot outer diameter (mm)	Soil pipe inner diameter (mm)	Weight	A	B	C
MKB21	108 – 114	99 – 105	0.24	45	80	80

Includes 40mm compression boss
Must be used in a vertical position if boss is being used

90° Tight Knuckle Bend old BS1213 Pans

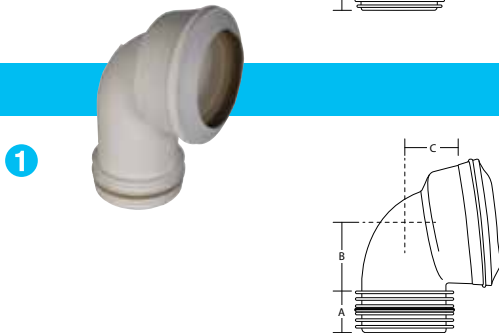

Code	Pan spigot outer diameter (mm)	Soil pipe inner diameter (mm)	Weight	A	B	C
MKB22	108 – 114	99 – 105	0.24	45	80	75

Ideal when replacing old BS1213 'S' trap pans
Can be cut to suit both horizontally and vertically

Straight 3/2" Soil

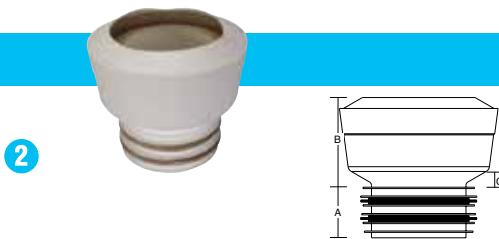

Code	Pan spigot outer diameter (mm)	Soil pipe inner diameter (mm)	Weight	A	B	C
MKS3	108 – 114	88 – 92	0.16	41	70	10

40mm vent boss

18mm Offset old BS1213 Pans to 3/2" Soil

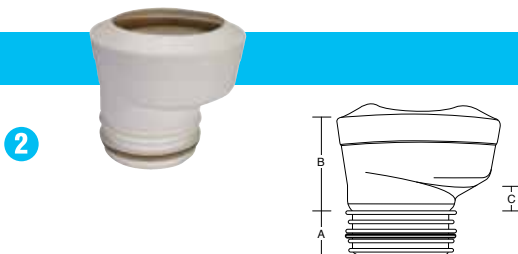

Code	Pan spigot outer diameter (mm)	Soil pipe inner diameter (mm)	Weight	A	B	C
MKO3	108 – 114	88 – 92	0.15	37	78	30

Straight 3/2" Soil

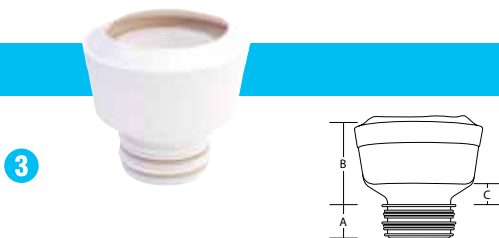

Code	Pan spigot outer diameter (mm)	Soil pipe inner diameter (mm)	Weight	A	B	C
MKS10	108 – 114	74 – 77	0.16	35	86	12

Adjustable length: remove the fined seal and cut with a fine tooth saw

90° Tight Knuckle Bend old BS1213 Pans to Oversize Soil

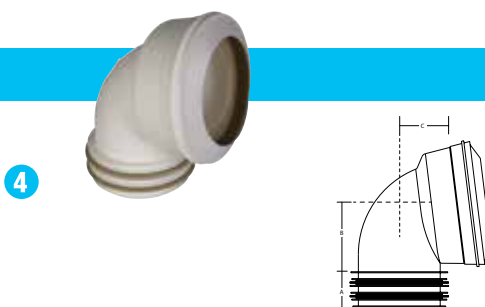

Code	Pan spigot outer diameter (mm)	Soil pipe inner diameter (mm)	Weight	A	B	C
MKB21S	108 – 114	105 – 108	0.25	45	75	60

PIPE: 1: Standard 99-105mm 2: Cast Iron 88-92mm 3: Old 74-77mm 4: Copper 105-108mm

Straight Undersize Spigots

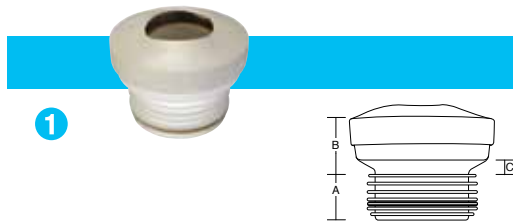

Code	Pan spigot outer diameter (mm)	Soil pipe inner diameter (mm)	Weight	A	B	C
MKS5	76 – 95	99 – 105	0.22	45	55	15

Extended Straight Undersize Spigots



Code	Pan spigot outer diameter (mm)	Soil pipe inner diameter (mm)	Weight	A	B	C
MKS8	76 – 95	99 – 105	0.26	42	110	70

Extension length: 59mm

18mm Offset Undersize Spigots

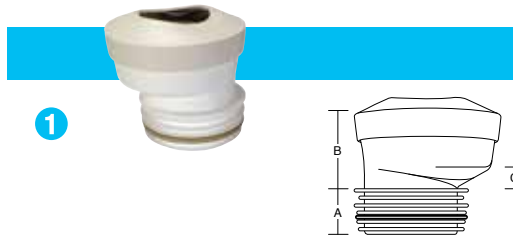

Code	Pan spigot outer diameter (mm)	Soil pipe inner diameter (mm)	Weight	A	B	C
MK05	76 – 95	99 – 105	0.24	45	72	22

14° Bend Undersize Spigots

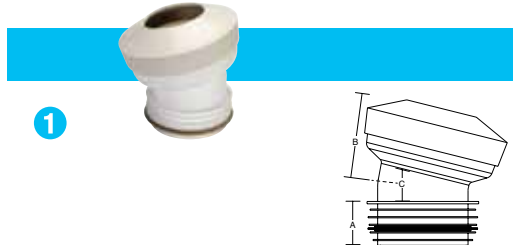

Code	Pan spigot outer diameter (mm)	Soil pipe inner diameter (mm)	Weight	A	B	C
MKB514	76 – 95	99 – 105	0.26	42	85	40

14° Bend Undersize Spigots to 3½" Soil

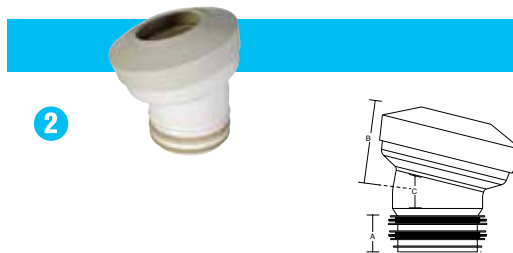

Code	Pan spigot outer diameter (mm)	Soil pipe inner diameter (mm)	Weight	A	B	C
MKB614	76 – 95	88 – 92	0.25	37	90	40

Soil Pipe Extension for 4" Soil



Code	Soil pipe inner diameter (mm)	Weight	A	B
MKEA	99 – 105	0.24	50	202

Can be cut to required length
Ideal when removing 4" cast iron, clay and PVCu

PIPE: 1: Standard 99-105mm 2: Cast Iron 88-92mm 3: Old 74-77mm 4: Copper 105-108mm

Soil Pipe Extension for 3½" Soil

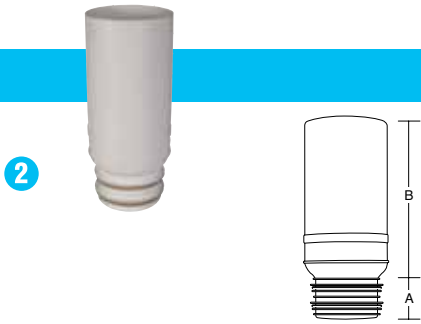

Code	Soil pipe inner diameter (mm)	Weight	A	B
MKEB	88 – 92	0.22	50	202

Can be cut to required length
Ideal when removing 3½" cast iron

Soil Pipe Extension for 3" Soil

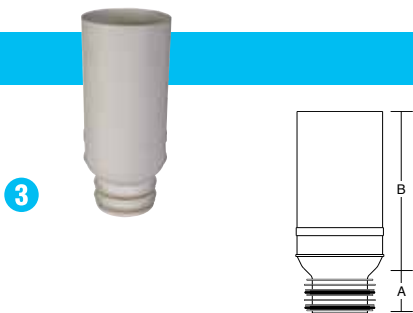

Code	Soil pipe inner diameter (mm)	Weight	A	B
MKEG	74 – 77	0.21	42	210

Can be cut to required length
Ideal when removing 3" cast iron

Rigid Soil Pipe Extension

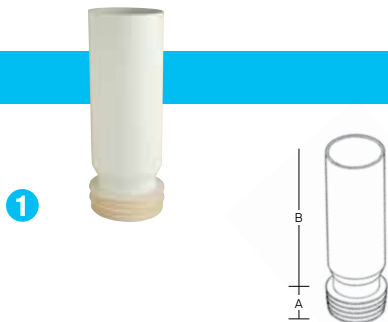

Code	Pan spigot outer diameter (mm)	Soil pipe inner diameter (mm)	Weight	A	B
MKREXT	97 – 108	99 – 105	0.23	35	264

Adjustable length: remove the fined seal and cut with a fine tooth saw

Flush Pipe Connector



Code	Soil pipe inner diameter (mm)	Weight	A	B
MKFPC1	–	0.02	65	26

Multilink

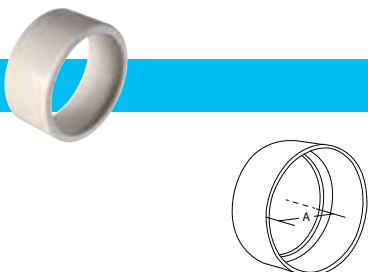

Code	Soil pipe inner diameter (mm)	Weight	A
MKL1	99 – 105	0.04	52.5

For connecting 2 or more pan connectors
Suitable for sleeving the fins of all 99 – 105mm Multikwik outlets



Branch

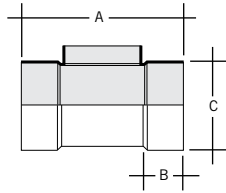

Size mm	Code	A	B	C	Colour	Qty
110x90	SM41W	214	50	116	W	10

Solvent sockets



Adjustable WC Bend

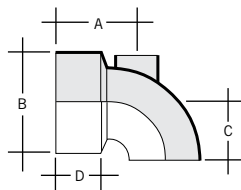

Size mm	Code	Angle	A	B	C	D	Colour	Qty
90	SM42W*	50-90°	108	134	75	60	W	15

50mm boss upstand

Pan socket to be trimmed to suit WC spigot length



Adjustable Spigot Bend

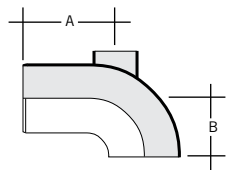

Size mm	Code	Angle	A	B	Colour	Qty
90	SM43W	50-90°	119	75	W	15

50mm boss upstand



WC Connector

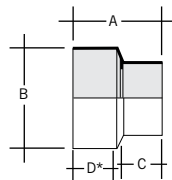

Size mm	Code	A	B	C	D	Colour	Qty
90	SM44W*	117	134	46	80	W	30

50mm boss upstand

Pan socket to be trimmed to suit WC spigot length



Extension Pipe

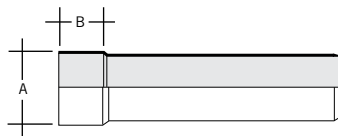

Size mm	Code	A	B	Colour	Qty
90	SM45W	96	46	W	50

300mm

For use with SM43 only



WC Seal and Cap

83-114mm outlet

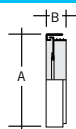

Size mm	Code	A	B	Colour	Qty
90	SA323W	141	24	W	70

For use with SM42 and SM44

*When fitted to short WC pan spigots, pan socket should be trimmed to suit before SA323W (not supplied) is fitted.



Bottle – Standard

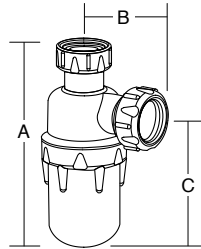

Size (mm)	Code	Colour	Water Seal Depth (mm)	Weight	Dimensions (mm) A x B x C
32	B032	White	75	0.15	180 x 74 x 125
40	B040	White	75	0.18	184 x 78 x 127



Bottle – Resealing

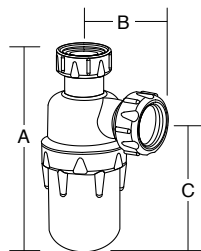

Size (mm)	Code	Colour	Water Seal Depth (mm)	Weight	Dimensions (mm) A x B x C
32	B032R	White	75	0.16	180 x 74 x 125
40	B040R	White	75	0.19	184 x 78 x 127

Resealing function to prevent loss of water seal



Bottle – Adjustable

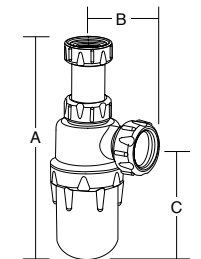

Size (mm)	Code	Colour	Water Seal Depth (mm)	Weight	Dimensions (mm) A x B x C
32	B032A	White	75	0.19	195 x 74 x 125
40	B040A	White	75	0.22	195 x 78 x 127

Adjustable inlet for installation flexibility
Min height: 195mm; max height: 300mm



Bottle – Adjustable / Resealing

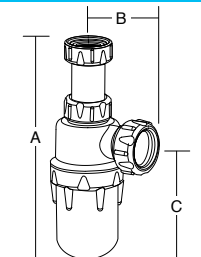

Size (mm)	Code	Colour	Water Seal Depth (mm)	Weight	Dimensions (mm) A x B x C
32	B032RA	White	75	0.20	195 x 74 x 125
40	B040RA	White	75	0.23	195 x 78 x 127

Adjustable inlet for installation flexibility
Resealing function to prevent loss of water seal
Min height: 195mm; max height: 300mm



Bottle – Anti-vac

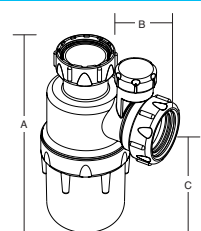

Size (mm)	Code	Colour	Water Seal Depth (mm)	Weight	Dimensions (mm) A x B x C
32	B032V	White	75	0.16	180 x 74 x 125
40	B040V	White	75	0.19	186 x 84 x 125

Resealing function to prevent loss of water seal
Anti-vac allows air into the waste pipes to prevent self-siphonage of the traps water seal and gurgling

Multikwik Traps

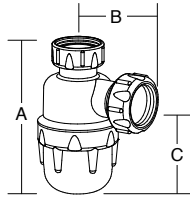

Bottle – Compact

Size (mm)	Code	Colour	Water Seal Depth (mm)	Weight	Dimensions (mm) A x B x C
32	B032S	White	75	0.12	136 x 75 x 85
40	B040S	White	75	0.13	152 x 81 x 100

Use when connecting into flat bottomed appliances that discharge into a gully

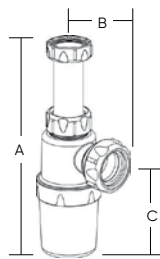

Bottle – Slimline

Size (mm)	Code	Colour	Water Seal Depth (mm)	Weight	Dimensions (mm) A x B x C
32	BS032	White	75	0.15	182 x 71 x 112

Space saving
Adjustable inlet for installation flexibility
Minimum height: 195mm; max height 300mm



Straight Through Adjustable

Size (mm)	Code	Colour	Water Seal Depth (mm)	Weight	Dimensions (mm) A x B x C
32	ST032	White	75	0.24	270 x 33

Unique slim-line design, saving space
Adjustable telescopic outlet for installation flexibility
Easy to clean and maintain

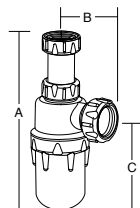

Bottle – Adjustable

Size (mm)	Code	Colour	Water Seal Depth (mm)	Weight	Dimensions (mm) A x B x C
32	B032ACR	Chrome	75	0.45	195 x 74 x 125

High quality mirror chrome finish
Includes 400mm x 32mm chromed pipe
Adjustable inlet for installation flexibility
Min height: 195mm; max height: 300mm

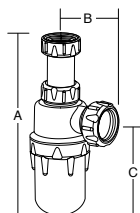

Bottle – Adjustable / Resealing

Size (mm)	Code	Colour	Water Seal Depth (mm)	Weight	Dimensions (mm) A x B x C
32	B032RACR	Chrome	75	0.25	195 x 74 x 125
40	B040RACR	Chrome	75	0.29	225 x 80 x 130

Resealing function to prevent loss of water seal
High quality mirror chrome finish
Adjustable inlet for installation flexibility
Min height: 195/225mm; max height: 300/327mm



Universal all in one

Size (mm)	Code	Colour	Water Seal Depth (mm)	Weight	Dimensions (mm) A x B x C x D
32	SP032	White	75	0.19	267 x 140 x 85 x 55
40	SP040	White	75	0.22	285 x 140 x 80 x 65

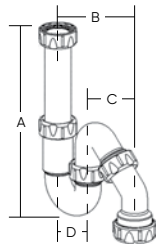

Adjustable inlet for installation flexibility
Multi position outlet adjusts 360° providing installation flexibility
Use as either an 'S' or 'P' trap



Running

Size (mm)	Code	Colour	Water Seal Depth (mm)	Weight	Dimensions (mm) A x B x C x D
32	RP032	White	75	0.16	135 x 130 x 115 x 60
40	RP040	White	75	0.20	160 x 145 x 130 x 65
50	RP050X	White	75	0.25	185 x 165 x 160 x 75

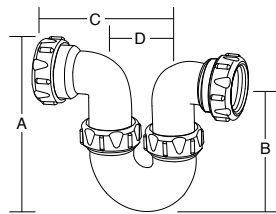

Use to trap a range of appliances



'P' Trap

Size (mm)	Code	Colour	Water Seal Depth (mm)	Weight	Dimensions (mm) A x B x C x D
32	P032	White	75	0.11	140 x 125 x 115 x 60
40	P040	White	75	0.14	165 x 145 x 130 x 65
50	P050	White	75	0.22	190 x 165 x 160 x 75

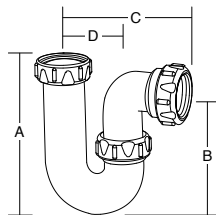

Use for horizontal pipework



'P' Trap – Adjustable

Size (mm)	Code	Colour	Water Seal Depth (mm)	Weight	Dimensions (mm) A x B x C x D
32	P032A	White	75	0.15	220 x 135 x 115 x 60
40	P040A	White	75	0.20	245 x 145 x 130 x 65

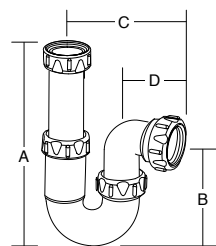

Adjustable inlet for installation flexibility
Min height: 220mm; max height: 270mm



'S' Trap

Size (mm)	Code	Colour	Water Seal Depth (mm)	Weight	Dimensions (mm) A x B x C x D
32	S032	White	75	0.14	160 x 110 x 55
40	S040	White	75	0.17	160 x 130 x 65

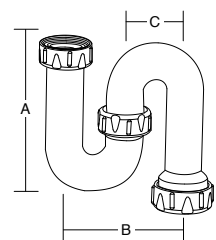

Use for vertical pipework

Tubular Swivel

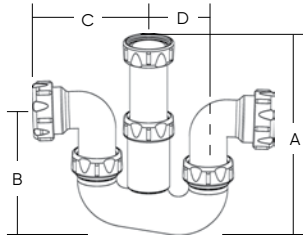

Size (mm)	Code	Colour	Water Seal Depth (mm)	Weight	Dimensions (mm) A x B x C x D
40	SWM040A	White	75	0.25	255 x 150 x 127 x 65

Adjustable inlet for installation flexibility
Inlet and outlet swivels to aid easy connection to pipes even in confined spaces

Shower – Compact

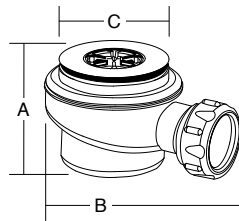

Size (mm)	Code	Colour	Water Seal Depth (mm)	Weight	Dimensions (mm) A x B x C
40 outlet	S5040C	White	50	0.18	92 x 150 x 70

Chrome waste
70mm flange
High flow rate: 0.76 l/s

Shower – Compact

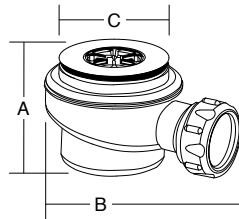

Size (mm)	Code	Colour	Water Seal Depth (mm)	Weight	Dimensions (mm) A x B x C
40 outlet	S5040W	White	50	0.18	92 x 150 x 70

White waste
70mm flange
High flow rate: 0.76 l/s

Shower – Resealing

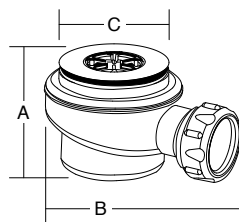

Size (mm)	Code	Colour	Water Seal Depth (mm)	Weight	Dimensions (mm) A x B x C
40 outlet	S5040CR	White	50	0.18	92 x 150 x 70

Chrome waste
Eliminates self-syphonage and gurgling through resealing device
70mm flange
High flow rate: 0.76 l/s



Bath – One Piece

Size (mm)	Code	Colour	Water Seal Depth (mm)	Weight	Dimensions (mm) A x B x C
40	P1940	White	19	0.08	70 x 75 x 145

For low level floors where a deeper water seal trap doesn't fit
For appliances that discharge into a gully

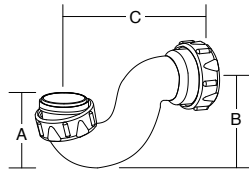

Bath – Low Level

Size (mm)	Code	Colour	Water Seal Depth (mm)	Weight	Dimensions (mm) A x B x C x D
40	P5040	White	50	0.15	140 x 110 x 89 x 172

Rodding point for cleaning

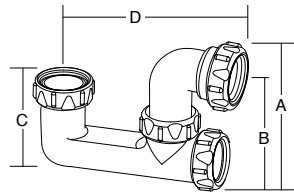

Bath – Low Level Anti-vac

Size (mm)	Code	Colour	Water Seal Depth (mm)	Weight	Dimensions (mm) A x B x C x D
40	P5040V	White	50	0.21	135 x 105 x 89 x 230

Anti-vac allows air into the waste pipes to prevent self-syphonage of the traps water seal and gurgling
Rodding point for cleaning

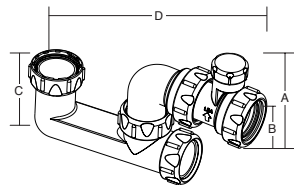

Bath – Swivel 'P' Low Level Inlet

Size (mm)	Code	Colour	Water Seal Depth (mm)	Weight	Dimensions (mm) A x B x C x D
40	P040L	White	75	0.13	125 x 150 x 127 x 65

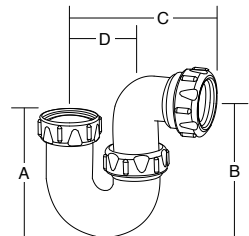

Bath – Standard

Size (mm)	Code	Colour	Water Seal Depth (mm)	Weight	Dimensions (mm) A x B x C x D
40	P6040	White	60	0.17	140 x 110 x 98 x 220

Rodding point for cleaning

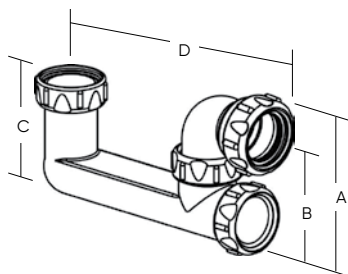

Bath – Low Level

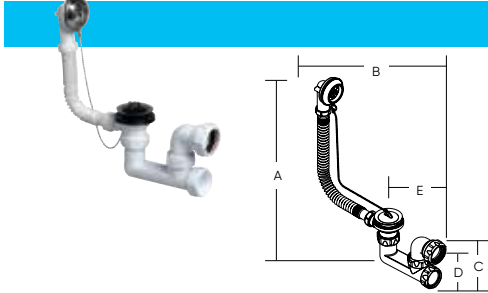

Size (mm)	Code	Colour	Water Seal Depth (mm)	Weight	Dimensions (mm) A x B x C x D x E
40	P5040F	White	50	0.37	355 x 325 x 140 x 115 x 175

Flexible overflow pipe for ease of installation
Plug tidy overflow to retain plug when not in use

Bath – Standard

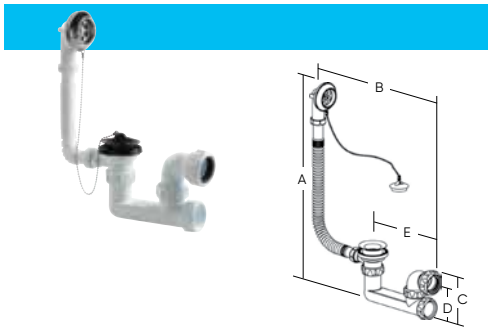

Size (mm)	Code	Colour	Water Seal Depth (mm)	Weight	Dimensions (mm) A x B x C x D x E
40	P6040F	White	60	0.39	410 x 375 x 140 x 115 x 220

Flexible overflow pipe for ease of installation
Plug tidy overflow to retain plug when not in use

Anti-Vac GurgleMaster

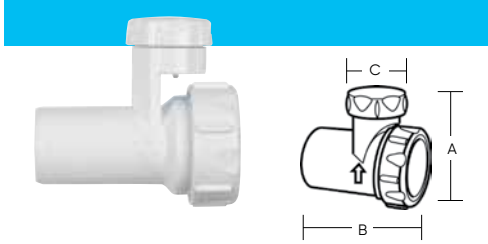

Size (mm)	Code	Colour	Weight	Dimensions (mm) A x B x C
32	WV032	White	0.05	80 x 90 x 39
40	WV040	White	0.06	90 x 90 x 40

Anti-vac allows air traps into the waste pipe to prevent gurgling and self-syphonage of the traps water seal
Quick installation with simple multi-fit in-line assembly

Anti-Syphon Unit



Size (mm)	Code	Colour	Weight	Dimensions (mm) A x B
32	WW150	White	0.05	57 x 61
40	WW151	White	0.05	60 x 61

To BS EN 12380
Anti-vac allows air into the waste pipe to prevent gurgling and self-syphonage of the traps water seal
Use with any BS EN 1566/5255 solvent weld sockets

Washing Machine

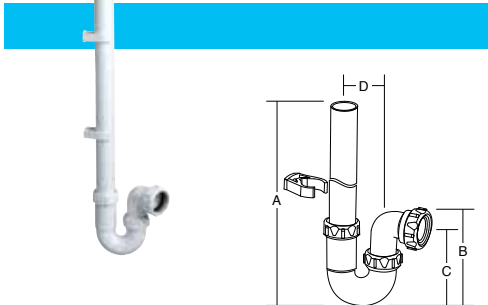

Size (mm)	Code	Colour	Water Seal Depth (mm)	Weight	Dimensions (mm) A x B x C x D
40	PWM040	White	75	0.29	560 x 160 x 140 x 65

Includes 500mm standpipe, retaining clips, screws and raw plugs



Utility 'P' Compact – Single Nozzle

Size (mm)	Code	Colour	Water Seal Depth (mm)	Weight	Dimensions (mm) A x B x C
40	PWM040T	White	75	0.21	190 x 145 x 270

Nozzle for connecting a washing machine or dishwasher

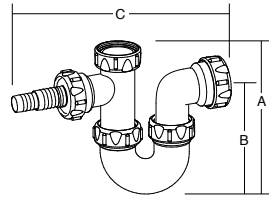

Adjustable Utility 'P' – Single Nozzle

Size (mm)	Code	Colour	Water Seal Depth (mm)	Weight	Dimensions (mm) A x B x C x D
40	PWM040S	White	75	0.20	250 x 215 x 145 x 65

Adjustable inlet for installation flexibility
For connecting a washing machine or dishwasher
Non-return valve to prevent backflow in nozzle
Min height: 250mm; max height: 310mm

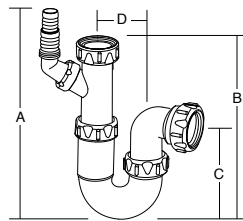

Adjustable Utility 'P' – Double Nozzle

Size (mm)	Code	Colour	Water Seal Depth (mm)	Weight	Dimensions (mm) A x B x C x D
40	PWM040D	White	75	0.23	250 x 215 x 145 x 65

Adjustable inlet for installation flexibility
For connecting two appliances
Non-return valve to prevent backflow in nozzle
Min height: 250mm; max height: 310mm

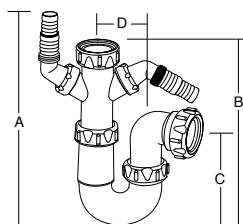

Adjustable Utility 'S' – Single Nozzle

Size (mm)	Code	Colour	Water Seal Depth (mm)	Weight	Dimensions (mm) A x B x C x D
40	SWM040S	White	75	0.24	250 x 217 x 125 x 65

Adjustable inlet for installation flexibility
For connecting a washing machine or a dishwasher
Non-return valve to prevent backflow in nozzle
Min height: 250mm; max height: 310mm

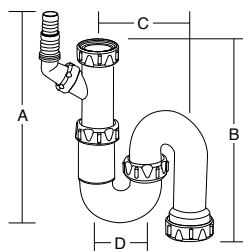

Adjustable Utility 'S' – Double Nozzle

Size (mm)	Code	Colour	Water Seal Depth (mm)	Weight	Dimensions (mm) A x B x C x D
40	SWM040D	White	75	0.26	250 x 220 x 125 x 65

Adjustable inlet for installation flexibility
For connecting a washing machine and dishwasher
Non-return valve to prevent backflow in nozzle
Min height: 250mm; max height: 330mm

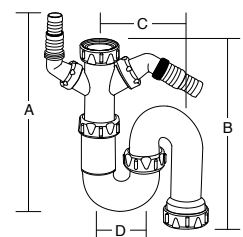

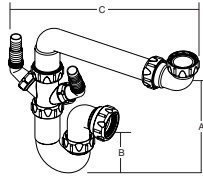

Space Saver kit

Size (mm)	Code	Colour	Water Seal Depth (mm)	Weight	Dimensions (mm) A x B x C
40	SBK040D	White	75	0.34	330 x 145 x 375

Single bowl, double nozzle
Flexible installation with full width and height adjustment

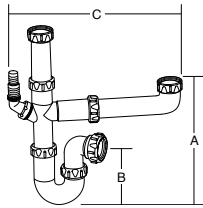

1½ Bowl Kit – Single Nozzle

Size (mm)	Code	Colour	Water Seal Depth (mm)	Weight	Dimensions (mm) A x B x C x D x E
40	XSB040S	White	75	0.36	410 x 140 x 395

Flexible installation with full width and height adjustment

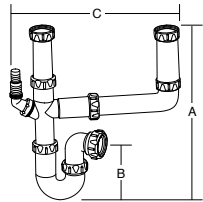

Double Bowl Kit – Single Nozzle

Size (mm)	Code	Colour	Water Seal Depth (mm)	Weight	Dimensions (mm) A x B x C
40	DBK040S	White	75	0.42	410 x 140 x 395

Flexible installation with full width and height adjustment

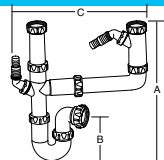
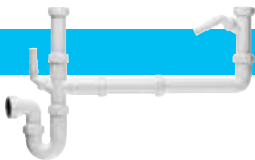

Extended Double Bowl kit – Double Nozzle

Size (mm)	Code	Colour	Water Seal Depth (mm)	Weight	Dimensions (mm) A x B x C
40	DBKDS040	White	75	0.49	410 x 140 x 610

Flexible installation with full width and height adjustment

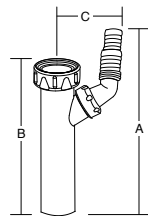

Trap Height Adjuster – Single Nozzle

Size (mm)	Code	Colour	Weight	Dimensions (mm) A x B x C
40	WA040S	White	0.07	195 x 150 x 70

For connections to a washing machine or dishwasher
Non-return valve prevents backflow in nozzle

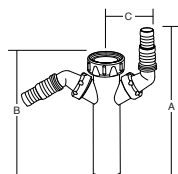
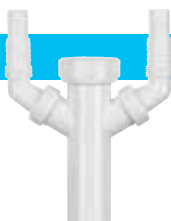

Trap Height Adjuster – Double Nozzle

Size (mm)	Code	Colour	Weight	Dimensions (mm) A x B x C
40	WA040D	White	0.10	195 x 150 x 78

For connections to a washing machine or dishwasher
Non-return valve prevents backflow in nozzle





Underground Drainage Systems

- Solid Wall Drainage Systems
- Inspection chambers
- Gullies

Solid Wall Drainage Systems

Key features

- 110mm & 160mm diameters
- Suitable for adoptable foul and surface water sewers
- Private foul and surface water applications.
- Plain ended and socketed pipe
- Adaptors to other materials
- Access fittings
- 250mm, 315mm and 450mm inspection chambers
- Adjustable and variable bends
- A wide range of gullies
- Manufactured to BS EN 1401
- BBA 88/1977 certification
- A number of solid wall fittings are also suitable for use with 150mm quantum and highway pipes

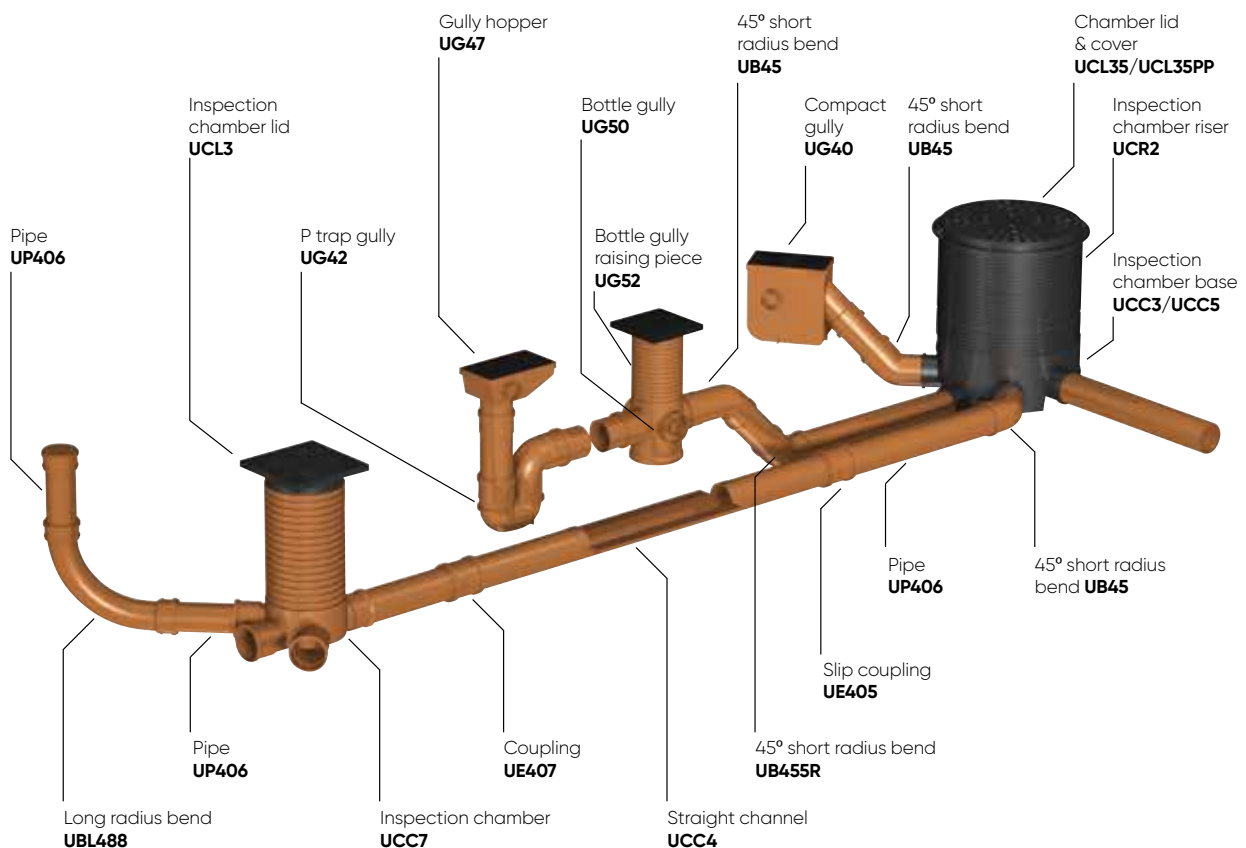
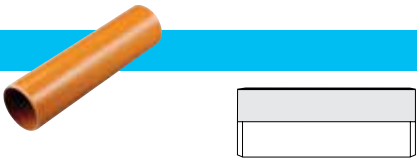







Diagram for illustrative purposes only







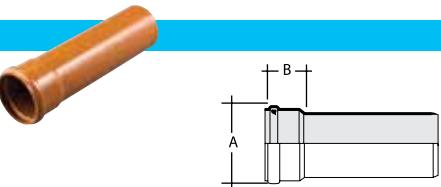

Pipe



Size mm	Code	Length	Colour	Qty
82	UL3057	5.7m	○	156*
110	UL403	3m	○  	100
110	UL406	6m	○  	100
160	UL606	6m	○  	46

Double spigot with chamfer each end



Size mm	Code	Length	A	B	Colour	Qty
82	UP3057	5.7m	100	76	○	156*
110	UP403	3m	128	70	○  	100
160	UP603	3m	182	107	○  	46
110	UP406	6m	128	70	○  	100
160	UP606	6m	182	107	○  	46

Push fit socket

Slotted Pipe





Size mm	Code	Length	A	B	Colour	Qty
110	UPP406	6m	128	70	○	1

Push fit socket

Straight Couplings

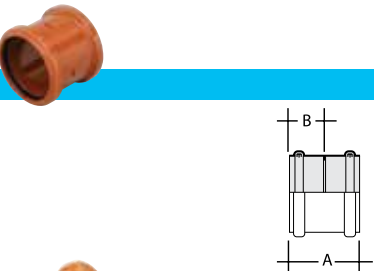
Push fit polypropylene coupling



Size mm	Code	A	B	Colour	Qty
110	UE407	102	50	○	 20

(Supplied in U.V. resistant polythene bags)





Push fit coupling



Size mm	Code	A	B	Colour	Qty
110	UE406	128	61	○  	 8
160	UME15C	170	83	○  	 4

Push fit slip coupling









Size mm	Code	A	Colour	Qty
82	UE305	104	○	100*
110	UE405	128	○  	8
160	UME16C	170	○  	4

Straight coupling









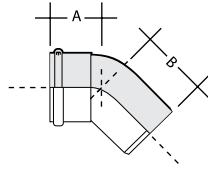





Loose pipe socket



Size mm	Code	Length	A	B	Colour	Qty
110	UE400	109m	61	48	○  	 8
160	UE600	190m	107	77	○  	 4









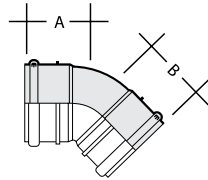

Short Radius Bends



Size mm	Code	Angle	A	B	Colour	Qty
82	UB31	90°	117	120	○	100*
110	UB41	87½°	175	182	○   	4
160	UFB61	87½°	236	232	○  	1
82	UB35	45°	75	73	○	100*
110	UB45	45°	145	125	○   	4
160	UFB65	45°	130	118	○   	1
110	UB430R	30°	89	82	○ 	4
160	UB69	30°	160	150	○   	1
110	UB420	20°	102	81	○	1
160	UB68	15°	150	110	○  	1
110	UB410	10°	98	75	○	1

Push-fit socket/spigot







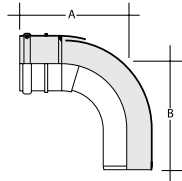

Size mm	Code	Angle	A	B	Colour	Qty
110	UB411	87½°	158	158	○   	4
160	UMB19C	87½°	200	200	○ 	1
110	UB455	45°	95	95	○   	4
160	UMB14C	45°	115	115	○ 	1
110	UB4300R	30°	80	80	○ 	4
160	UMB13C	30°	105	105	○ 	1
110	UB4200	20°	102	81	○	1
160	UMB11C	15°	95	95	○ 	1
110	UB4100	10°	98	76	○	1

Double push-fit socket

Adjustable Bends



Size mm	Code	Angle	A	B	Colour	Qty
110	UB47	21 – 90°	210	205	○   	4
160	UB67	15 – 90°	285	275	○   	2

Socket should be solvent welded

Multiflex Bends

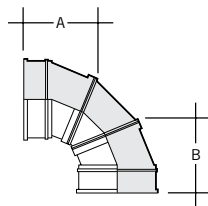

Size mm	Code	Angle	A	B	Colour	Qty
110	USB110	0 – 90°	205	205	○	1

Single socket

Size mm	Code	Angle	A	B	Colour	Qty
110	UDSB110	0 – 90°	205	205	○	1

Double socket

Mechanical Bend

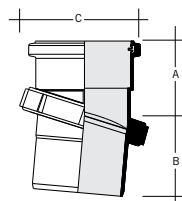

Size mm	Code	Angle	A	B	Colour	Qty
110	UB47M	5 – 30°	200	177	○	1

Key: ○ Orange B Black  British Board of Agrément certified product  Kitemark certified product  CAD drawing available for download from marleypd.co.uk * Denotes minimum order quantity

Long Radius Bend

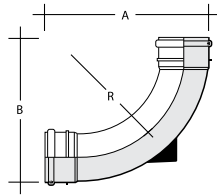

Size mm	Code	Angle	A	B	R	Colour	Qty
110	UBL488	87½°	310	360	270	○	4

Socket/socket

Equal Branches

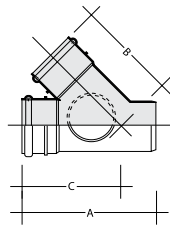

Size mm	Code	Angle	A	B	C	Colour	Qty
110	UY401	87½°	300	150		○	4
160	UY601	87½°	400	200		○	2
82	UY36	45°	231	155	155	○	100*
110	UY46	45°	320	205	205	○	4
160	UY63	45°	400	280	280	○	2

Socket/spigot

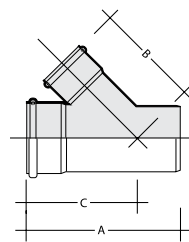

Size mm	Code	Angle	A	B	C	Colour	Qty
110	UY400	87½°	300	150		○	4
160	UMY13C	87½°	400	200		○	2
110	UY466	45°	325	215	200	○	4
160	UMY11C	45°	400	280	280	○	2

All socket

Unequal Branches

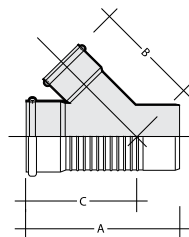

Size mm	Code	Angle	A	B	C	Colour	Qty
160 x 110	UY64	87½°	340	180	126	○	2
160 x 110	UY66	45°	357	245	254	○	2

Socket/spigot

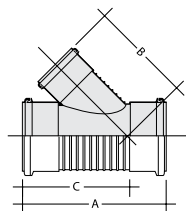

Size mm	Code	Angle	A	B	C	Colour	Qty
160 x 110	UMY12C	87½°	340	180	252	○	2
160 x 110	UMY10C	45°	316	232	236	○	2

All socket

Access Bend

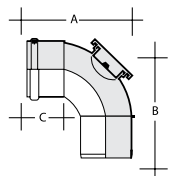

Size mm	Code	Angle	A	B	C	Colour	Qty
110	UB42	87½°	172	174	80	○	4

With rear access, socket/spigot
Fitted with a twist and lock access cap which can be secured with a No. 8 screw

Rodding Point

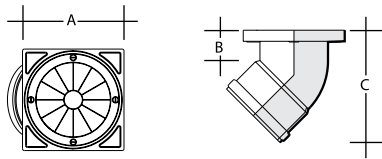

Size mm	Code	Angle	A	B	C	Colour	Qty
110	URP1	45°	164	68	70	○	10

A15 loading. Black cover with four screw fixings and seal

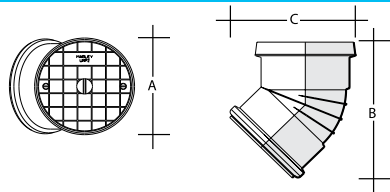

Size mm	Code	Angle	A	B	C	Colour	Qty
160	URP2C	45°	190	92	89	○	4

A15 loading. Aluminium cover with two screw fixings

Square Rodding Point Cover (Spare)

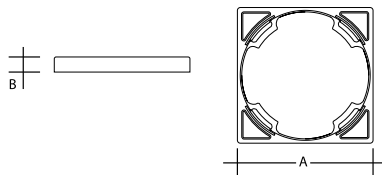

Size mm	Code	A	B	Colour	Qty
110	URPFsq	163	18	B	10

For use with URP1

Access Cap

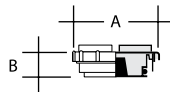

Size mm	Code	A	B	Colour	Qty
110	UE42	130	30	○	50
160	UE62	195	40	○	15

Solvent socket

Pressure Plug

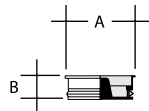

Size mm	Code	A	B	Colour	Qty
110	UE43	110	30	○	135
160	UE64	160	30	○	30

Push fits into plain end of pipe

450mm Inspection Chamber bases

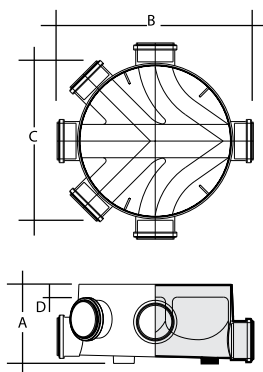

Size mm	Code	A	B	C	D	Colour	Qty
110	UCC3	245	608	608	50	B	1

Supplied with 4 blanking plugs. Max invert depth 1.2m (when used with UCR2 riser). 245mm high. All 110mm connections.

The 'D' dimension relates to the height of side branches above invert of main channel

Key: ○ Orange B Black G Grey British Board of Agrément certified product Kitemark certified product
 CAD drawing available for download from marleypd.co.uk * Denotes minimum order quantity

450mm Inspection Chamber Bases

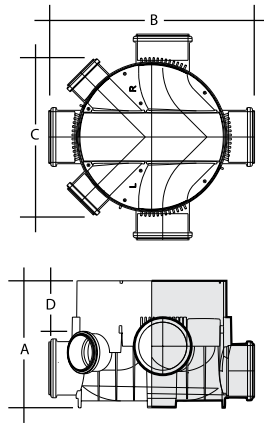

Size mm	Code	A	B	C	D	Colour	Qty
110/160	UCC5	80	75	490	192	B	1

The A and B dimensions relate to the height of side branches above invert level of main channel.

Max invert depth 4m (when used with UCR3 riser)

All socket connections. 400mm high, 110 and 160mm, connections.

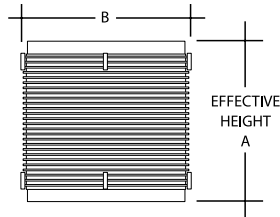

Chamber Riser

Size mm	Code	A	B	Colour	Qty
450	UCR2	390	450	B	1

Push fit ring seal joint into chamber base. 430mm high, includes one 450mm seal.

For use with UCC3/5 for invert depths up to 1.2m

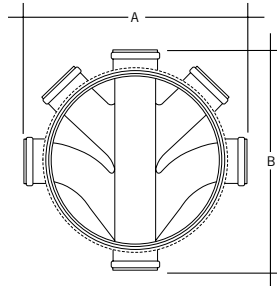

Deep Inspection Chamber

Size mm	Code	A	B	Colour	Qty
110	UCC3D	608	608	B	1

Max invert depth 4m (when used with UCR3 riser)

All socket connections.

655mm high

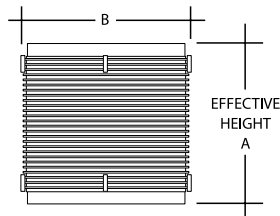

Deep inspection Chamber Riser

Size mm	Code	A	B	Colour	Qty
450	UCR3	410	488	B	1

For use with UCC3D or UCC5 when invert depth is greater than 1.2m.

Max invert depth 4m

480mm high

Includes one 450mm seal

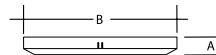

Reduced Access Ring

Size mm	Code	A	B	Colour	Qty
450	UCLRR	60	455	B	1

Provides 350mm restricted opening. Snap lock connection to the frame of the UCL35PP and UCL35SQ.

For use with UCL35PP

Cast Iron Cover and Frame

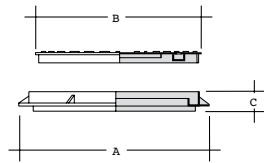

Size mm	Code	A	B	C	Colour	Qty
450	UCL35	517	490	40	B	1

3.5 tonnes. Domestic driveway loading

Polypropylene Cover and Frame

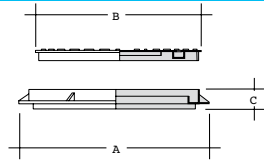

Size mm	Code	A	B	C	Colour	Qty
450	UCL35PP	547	494	70	B	1

3.5 tonnes. Domestic driveway loading

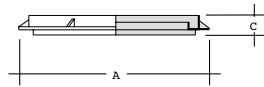

Size mm	Code	A	B	C	Colour	Qty
450	UCL35SQ	547	494	70	B	1

3.5 tonnes. Domestic driveway loading

Ductile Iron Lid and Cast Iron Frame

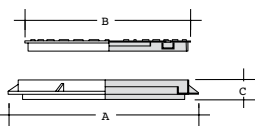

Size mm	Code	A	B	C	Colour	Qty
450	UCL125	547	492	48	B	1

12.5 tonnes

Chamber riser clip

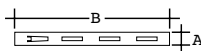
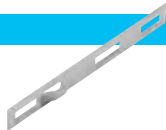

PK10

Code	A	B	Qty
UCC10	19	200	10

For use with UCR2 riser

Deep Inspection Chamber Riser Clip

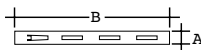
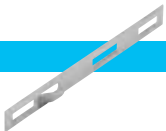

PK10

Code	A	B	Qty
UCC10D	19	204	10

For use with UCR3 riser.

Zintec coated, supplied in packet of 10.

Used to connect chamber to riser and riser to riser.

Inspection chamber inserts

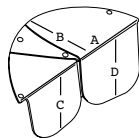

	Code	A	B	C	D	Colour	Qty
Left hand	UCB1	425	159	171	167	B	1
Right hand	UCB2	425	159	167	171	B	1

For use with the UCC5 inspection chamber

Spare blanking plug

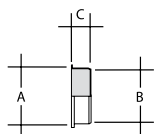

Size mm	Code	A	B	C	Colour	Qty
110	UCP1	117	110	40	B	70
160	UCP2	165	160	60	B	1

Black polypropylene
For use with UCC3/5

Spare ring seal

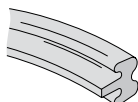

Size mm	Code	Colour	Qty
450	SR450	B	1

For use with UCR2/3

315mm adoptable inspection chamber Suitable for up to 2m in depth

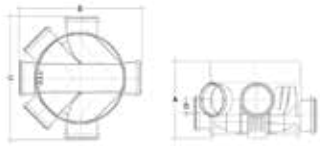

Inspection Chamber Base

Size mm	Code	A	B	C	D	Colour	Qty
315	UCC315	285	462	462	50	A B	1

Supplied with 4 blanking plugs. Max invert depth 2m (when used with UAR2/3 riser). All 110mm connections

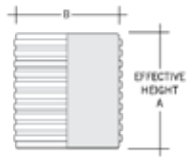

Chamber riser

Size mm	Code	A	B	C	D	Colour	Qty
300	UAR2	504	300			A O	1

500mm tall. Includes 300mm seal

300	UAR3	1008	300			A O	1
-----	-------------	------	-----	--	--	-----	---

1m tall. Includes 300mm seal

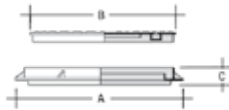

Ductile Iron Lid and Cast Iron Frame

Size mm	Code	A	B	C	Colour	Qty
300	UCL315		341	288	55	A B

Solvent socket to boss upstand

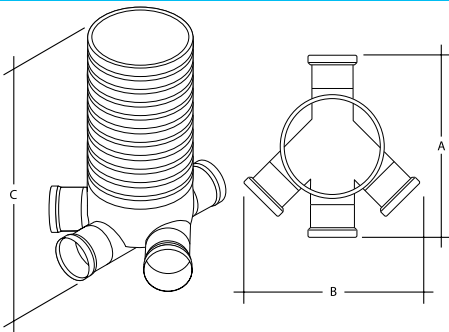

Level Invert Inspection Chamber

Size mm	Code	A	B	C	Colour	Qty
250	UCC7	380	420	600	O	1

Maximum invert depth – 600mm
All 110mm socket connections

Size mm	Code	A	B	Colour	Qty
300	UAR4	280	300	O	1

280mm tall. Includes 300mm seal

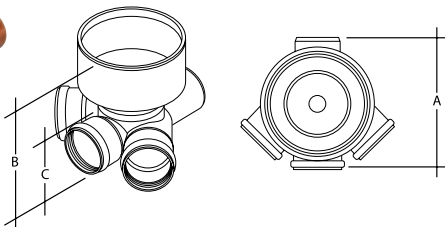

Double branch chamber base

Size mm	Code	A	B	C	Colour	Qty
250	UAC44	344	275	170	O	1

45° equal connections
Includes two socket plugs and profiled insert
Maximum invert depth – 600mm

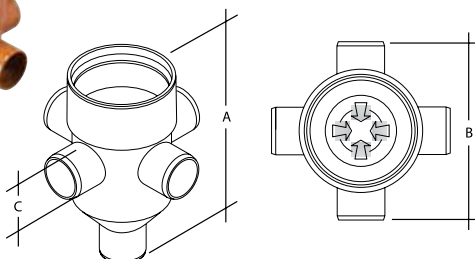

Bottom outlet chamber body

Size mm	Code	A	B	C	Colour	Qty
250	UAC02	428	415	120	O	1

Maximum invert depth to side connections – 600mm
90° equal connections
4 x 110mm upstands, 3 open connections

Inspection Chambers

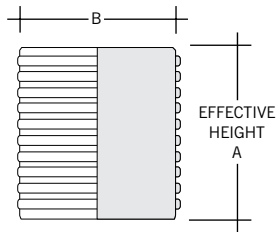

Chamber riser

Size mm	Code	A	B	Colour	Qty
250	UARI	375	250	○	1

For use with UAC44 & UAC02.
Includes 250mm seal.

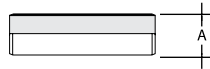

Lifting handle

Size mm	Code	Length	A	Colour	Qty
40	KP204W	4	40	W	10

For use with UAC44

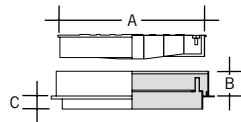

Inspection Chamber Lid & Frame

Size mm	Code	A	B	C	Colour	Qty
250	UCL2	280	50	20	B	1

PVCu (A15 loading)

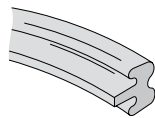

Spare Ring Seal

Size mm	Code	Colour	Qty
250	SR250	B	1

Optional for UCL2 PVCu lid

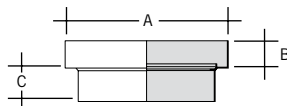

Square Lid & Frame

Size mm	Code	A	B	C	Colour	Qty
250	UCL3	318	20	78	B	1

A15 loading

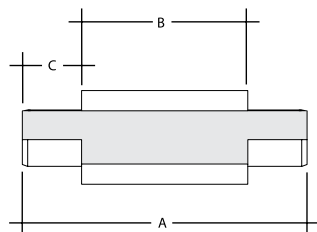

Straight Double Spigot Open Channel

Size mm	Code	A	B	C	Colour	Qty
110	UCC4	1500	610	445	○	1

Double spigot, keyed for sand/cement benching
1.5m long, with 600mm opening

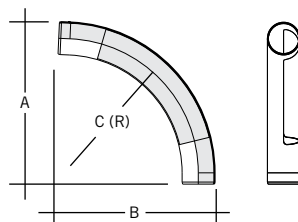

Long Radius Open Channel Bend

Size mm	Code	Angle	A	B	C	Colour	Qty
110	UCB48L	87½°	310	360	270	○	1

Double spigot, keyed for sand/cement benching

Slipper bends

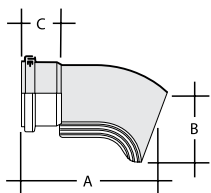

Size mm	Code	A	B	C	Colour	Qty
Left hand						1
110	USB41	230	120	65	○	1
Right hand						1
110	USB42	230	120	65	○	1

Push-fit socket, keyed for sand/cement benching.
Bend may be trimmed to adjust the angle of entry to the manhole.

Level Invert Reducers

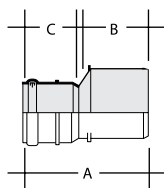

Size mm	Code	A	B	C	Colour	Qty
110 – 82	URM304	135	67	54	○	4
160 – 110	URM604	219	90	82	○	4

Spigot/socket

Concentric Reducers

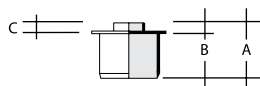

Size mm	Code	A	B	C	Colour	Qty
110 – 50	SE41	103	80	19	B G	1

Spigot to boss upstand

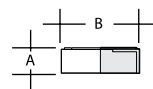

Size mm	Code	A	B	Colour	Qty
110	UA42	31	104	B	100

110 x 68/65mm

Eccentric Reducers

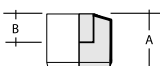

Size mm	Code	A	B	C	Colour	Qty
82 – 50	SRM30	70	48	19	B G	90
110 – 50	SRM402	48	25	19	B G	10

Solvent socket to boss upstand

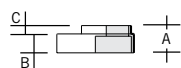
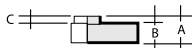

Size mm	Code	A	B	C	Colour	Qty
110 – 68	URM425	40	25	12	○	10
110	UA43	58	25	34	B	1

URM425 Solvent socket to 68mm downpipe
UA43 Universal waste to 110mm drain

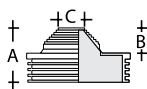

Bottle Gully

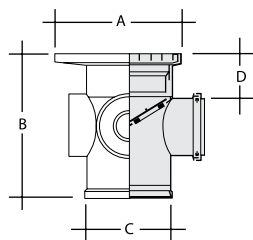
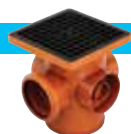

Size mm	Code	A	B	C	D	Colour	Qty
110	UG50	237	277	152	95	○	1

A15 loading
Push fit socket outlet, three 110mm solvent weld inlets with 50mm boss upstands and rodding access

Bottle gully with back inlet plugged

Size mm	Code	A	B	C	D	Colour	Qty
110	UG50D	237	277	152	95	○	1

A15 loading

Key: ○ Orange B Black W White British Board of Agrément certified product Kitemark certified product
 CAD drawing available for download from marleypd.co.uk

Gullies

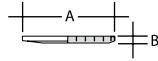
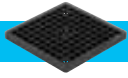

Spare Bottle Gully Grid

Size mm	Code	A	B	Colour	Qty
Sealed lid	UG51	228	23	B	1
Sealed lid	UG51SA	228	45	B	1

For use with UG50 bottle gully

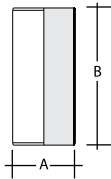



Bottle Gully Raising Piece

Size mm	Code	A	B	Colour	Qty
160	UG52	160	352	O	1

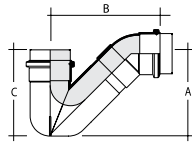
For use with bottle gully UG50 to adjust invert level of trap outlet





'P' Trap Gully

Size mm	Code	A	B	C	Colour	Qty
110	UG42	230	306	211	O  	1

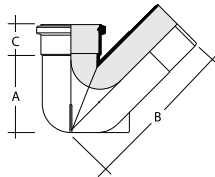
Push-fit socket inlet, 87½° socket outlet



Gully Trap Base

Size mm	Code	A	B	C	Colour	Qty
110	UG44	170	294	28	O  	4

Solvent socket inlet, 45° spigot outlet

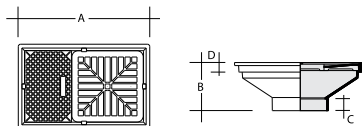

Rectangular Hopper

Size mm	Code	A	B	C	Colour	Qty
110	UG47	232	142	50	O 	4

Solvent socket, accepts 68mm downpipe inside larger boss with two 50mm boss upstands
Grating meets requirements of BS 4660: 2000 load Class K3

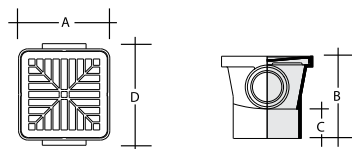

Square Hopper

Size mm	Code	A	B	C	Colour	Qty
110	UG48	160	142	50	O	4

Solvent socket, accepts 68mm downpipe inside larger boss with two 50mm boss upstands
Grating meets requirements of BS 4660: 2000 load Class K3

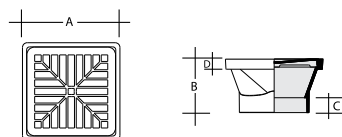

Grating Assembly

Size mm	Code	A	B	C	D	Colour	Qty
110	UG45	165	91	25	17	O 	30

Solvent socket
Grating meets requirements of BS 4660: 2000 load Class K3

Key: O Orange B Black W White  British Board of Agrément certified product  Kitemark certified product
 CAD drawing available for download from marleypd.co.uk

Spare Gully Grid

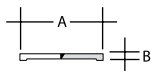
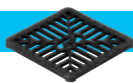

Size mm	Code	A	B	Colour	Qty
110	UG46	148	12	B	20

For use with UG40 gully and UG45, UG47 & UG48 gully hoppers

Spare Gully Back Plate

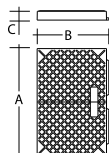

Size mm	Code	A	B	C	Colour	Qty
110	UG49	150	80	16	B	20

For use with UG40 gully and UG47 gully hoppers

Inlet Raising Pieces

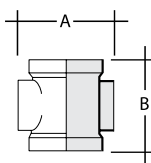

Size mm	Code	A	B	Colour	Qty
110	UWS43	148	156	O	4

2 x 82mm upstands

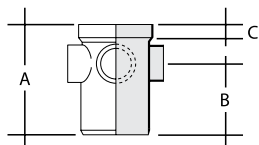

Size mm	Code	A	B	C	Colour	Qty
110	UW401	181	125	20	O	4

Solvent socket/spigot, four 50mm boss upstands, one open

Yard Gully

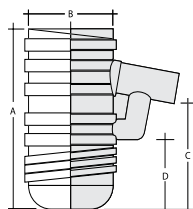

Size mm	Code	A	B	C	D	Colour	Qty
110	UYG40	634	315	392	238	B	1

Black high density polyethylene with spigot outlet and removable rodding access plug

Grating and Frame for Yard Gully

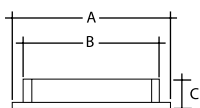

Size mm	Code	A	B	C	Colour	Qty
400	UYG42	400	320	75	B	1

Cast iron with hinged grating
B125 loading (12.5 tonne test load) suitable for car park areas

Adaptors

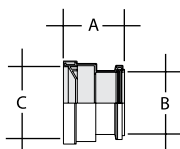

Size mm	Code	A	B	C	Colour	Qty
110	UCA40	120	110	130	B	1

Socket/socket to suit thin wall clayware spigot pipe

Size mm	Code	A	B	C	Colour	Qty
110	UCA41	120	110	138	B	1

Socket/socket to suit thick wall clayware pipe

Anti-Flood Valve

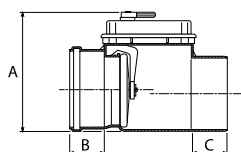

Size mm	Code	A	B	C	Colour	Qty
110	USW130	175	52	69	B	1
160	USW140	225	100	92	B	1

Double flap





Soil & Waste Installation Guide

- Design considerations
- Stack design considerations
- Jointing guide
- Pipe Support
- Connection systems guide
- Handling, storage & safety

Soil & Waste – Design Considerations

All sanitary pipework systems should be designed to satisfy the following regulations and standards where applicable.

The Building Regulations 2010: Approved Document H, Section 1.

The Building Standards Technical Handbook (Scotland) 2010: Part M.

The Building Regulations (Northern Ireland) 2000, Technical Handbook N.

BS EN 12056: 2000, Parts 1 to 5.

Regular consultation is essential between Architects and Plumbing Engineers throughout the building design stage as the careful arrangement of kitchen and bathroom appliances will simplify the final sanitary pipework layout. This will help to ensure that an efficient sanitary pipework system is

installed at minimum cost.

The design information provided in this catalogue is endorsed in the above publications and while every effort has been made to ensure accuracy, no responsibility can be accepted for errors or omissions. For detailed guidance please consult the relevant documents referred to above.

Building Information Modelling (BIM)

Marley PVCu soil systems are now available to download in Autodesk Revit digital format from the BIM library at Bimstore:

<https://www.bimstore.co/manufacturers/marley-plumbing-and-drainage>

AutoCAD format are also available.

Material and manufacture

Marley Plumbing & Drainage pipes and fittings for sanitary pipework systems are manufactured from different plastics materials including uPVC, PVC-c and ABS.

The table below details the important dimensions and weights of each of the systems together with the relevant British and European Standards we manufacture to. All pipes are manufactured using a continuous extrusion process and fittings are produced by high-pressure injection moulding.

Table 1: Pipe dimensions and weights

Pipe Material Standard	BS Nominal Size (mm/inch)	Mean Outside Diameter (mm)		Wall Thickness (mm) Min		Weight kg/metre
		Min	Max	Min	Max	
Soil PVCu						
Pipe: BS 4514	82	82.4	82.0	3.0		1.30
Pipe: BS EN 1329	110	110.0	110.3	3.20		1.70
	160	160.0	160.4	3.20		2.50
Waste PVC-c						
Fittings: BS 5255	36/1¼	36.15	36.5	1.80		0.33
Pipe: BS EN 1566	40/1½	42.75	43.1	1.90		0.41
	50/2	55.75	56.1	2.00		0.57
Waste ABS						
Pipe and fittings:	32/1¼	36.15	36.5	1.80		0.20
	43/1½	42.75	43.1	1.90		0.26
BS EN 1455	50/2	55.75	56.1	2.00		0.35
Waste Polypropylene						
Pipe: BS EN 1451	32/1¼	34.45	34.8	1.80		0.21
	40/1½	40.85	41.2	1.90		0.26
Overflow PVCu						
	21.5/¾	21.55	21.70	1.10		0.11

Chemical and temperature resistance

Most plastics used for sanitary pipework are highly resistant to those chemicals normally found in domestic waste water and sewerage systems. For applications where chemical discharges are likely to occur, Vulcathene product range is more ideal.

Generally the maximum working temperature of Marley PVCu and PVC-c when subjected to continuous flow is 70°C and 75°C respectively. Higher intermittent discharges of up to 95°C may be accommodated by PVCu provided the period of discharge does not exceed one minute duration.

Alternatively, reference can be made to ISO publications TR10358 & TR7620 which provide comprehensive information on chemical and temperature resistance of plastics and rubber materials.

Thermal Movement

The coefficient of linear expansion for PVCu is 0.06mm/m/°C. As a result a 3m length of pipe will increase in length by approximately 3.6mm when subjected to a 20°C temperature variation.

Therefore, it is important to ensure that any movement is controlled and push-fit joints are installed to accommodate any expansion that may occur due to increases in ambient temperature or hot water discharges.

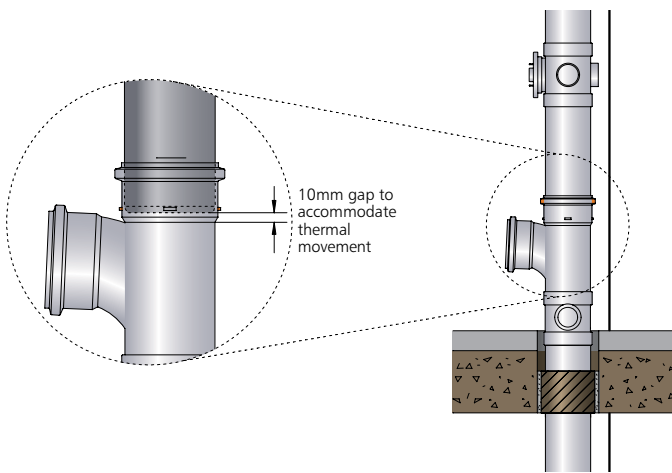

Fig 1. Typical Ø110mm **soil pipe** branch with push-fit ring seal joint on each floor to allow for thermal expansion

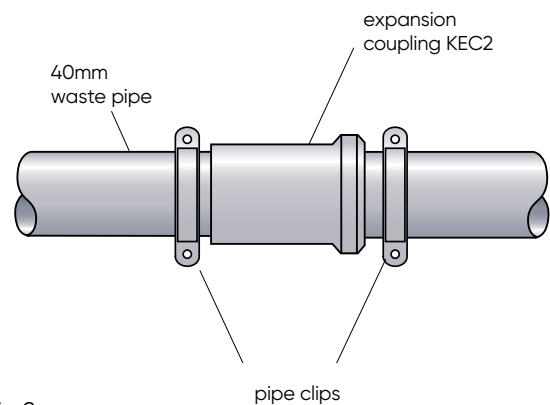

Fig 2. Ø40mm **waste pipe** expansion coupler. Needed where pipe length exceeds 1.8m between fixed points.

Calculation of Flowrate

Waste water flowrate Q_{ww} is the expected flowrate of waste water in a part or in the whole drainage system where only domestic sanitary appliances are connected to the system.

$$Q_{ww} = K \sqrt{\Sigma DU}$$

Where: Q_{ww} = waste water flowrate (l/s)

K = Frequency factor (table 2)

ΣDU = Sum of discharge units (table 1)

Table 1

Appliance	Discharge Units (DU), l/s
WC, 6L cistern (1.2 - 1.7L/s)	1.7
Wash basin	0.3
Bath	1.3
Shower tray (no plug)	0.4
Kitchen sink	1.3
Urinal (cistern flush) per person	0.2
Bidet	0.3
Dishwasher, domestic	0.2
Washing machine, up to 6 kg	0.6
Washing machine, up to 12 kg	1.2

Table 2

Frequency of Use Factors

Intermittent use, e.g. House, flat, offices	0.5
Frequent use, e.g. Hotel, school, hospital	0.7
Congested use, e.g. Public use	1.0
Special use, e.g. Laboratory	1.2

Vertical Soil Stack Capacity

Primary Ventilated Stack Option	DU
82mm Discharge Stack (no WC's)	2.6
110mm Discharge Stack	5.2
160mm Discharge Stack	12.4

Secondary Ventilated Stack Option	DU
82mm Stack & 50mm 2nd Vent (no WC's)	3.4
110mm Stack & 50mm 2nd Vent	7.3
160mm Stack & 82mm 2nd Vent	18.3



Fire Protection

The Building Regulations 1991 (as amended) require that a building shall be sub-divided into compartments where necessary to inhibit the spread of fire. Plastics pipework is permitted to penetrate separating walls, compartment walls and floors provided the appropriate measures are taken to prevent the spread of fire in accordance with Part B of the Approved Document (2010).

To comply with this, pipes must be enclosed within a fire resistant enclosure which extends from floor to ceiling within each storey. The enclosure must have a class 'O' internal surface and have each side formed by a separating wall, external wall or by casing. Any casing must have a minimum 1/2 hour fire resistance and penetrations of the duct must be limited to 160mm vertical and 110mm horizontal.

Where longer periods of fire resistance are required, fire collars or pipe wraps can be fitted.

Tests carried out at FIRTO on a variety of typical sanitary pipework arrangements proved that it was possible to achieve up to 1 1/2 hour fire rating through a compartment floor without a fire collar or pipe wrap where the stack was terminated by an air admittance valve.

Various other arrangements were also tested and achieved a minimum of 2 hours integrity.

The construction illustrated below achieved a 1 1/2 hour fire resistance rating without the need for a fire resistance enclosure. The enclosure is necessary to achieve a 2 hour rating.

Please contact a fire protection specialist to ensure stack protection against any possible fire.

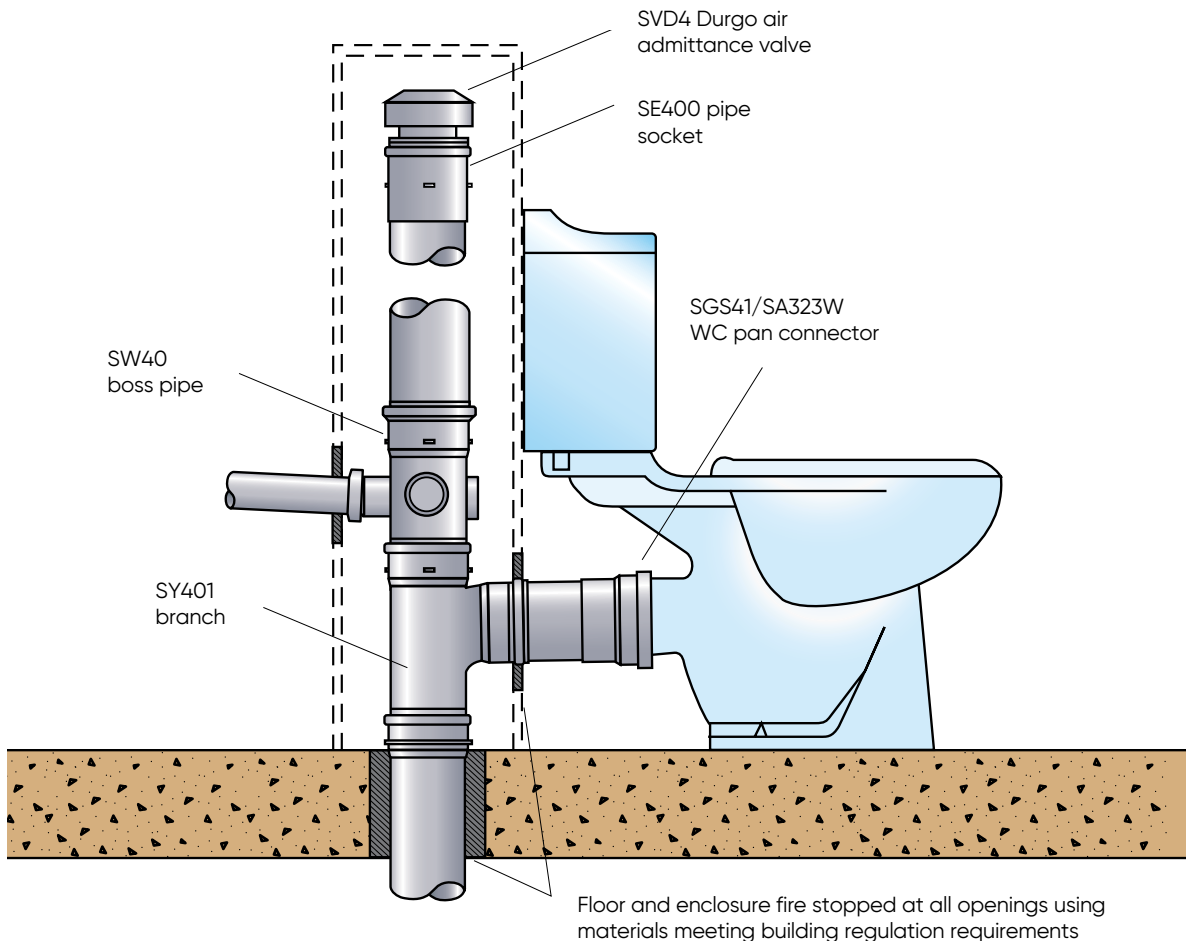

Soil & Waste – Handling, storage and safety

Handling

PVCu pipes are strong, though lightweight and therefore very easily handled. However, reasonable care should be exercised while handling, particularly in extremely cold conditions. Pipes should preferably be loaded and unloaded by hand but if mechanical handling is used, protected slings are recommended.

Inspection and testing

Inspection and testing should be carried out in accordance with BS EN 12056: 2000 and Building Regulations noting especially the details given in respect of air testing and the fact that smoke testing of plastics pipework should be avoided as the materials can be adversely affected.

Maintenance

Provided that the system is designed and installed correctly, no maintenance will be required. If blockage does occur, use only flexible or roller

type rods. Pointed or bearing type metal fittings are not recommended. Tests have been carried out on PVCu pipes and fittings using equipment from specialist drain cleaning contractors and their standard equipment is suitable.

Air test

The installation should be capable of withstanding an air test of positive pressure of at least 38mm water gauge for at least 3 minutes. During this time every trap should maintain a water seal of at least 25mm.

Safety

The relevant regulations are outlined in the Health and Safety At Work Act 1974 and The Construction (Design and Management) Regulations 1994 and should be followed. Hazard sheets, dealing with the correct storage, use, and any hazards of working with solvent cement, silicone lubricant and fire protection products are available from Marley Plumbing & Drainage.



Storage

Pipes should be stacked on a reasonably flat, level surface on timber battens not less than 75mm wide spaced at a maximum of 1m centers. Side support should also be provided at intervals of not more than 1.5m.

Different size pipes should be stacked separately. However, where this is not possible, larger diameter pipes should be placed at the bottom.

Spigot and socket pipes should be stacked separately. However, where this is not possible, larger diameter pipes should be stacked with sockets at alternate ends protruding to ensure pipes are evenly supported along their length.

Pipes should not be stacked more than 7 high and when stored in the open for long periods, or exposed to strong sunlight, they should be covered with an opaque sheet.

Fittings supplied in cardboard boxes or polythene bags should be stored under cover and kept packed until required. Solvent cement should be stored in a cool place out of direct sunlight and away from any heat source.

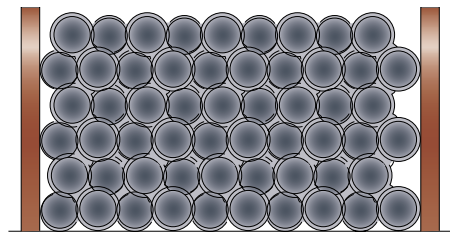
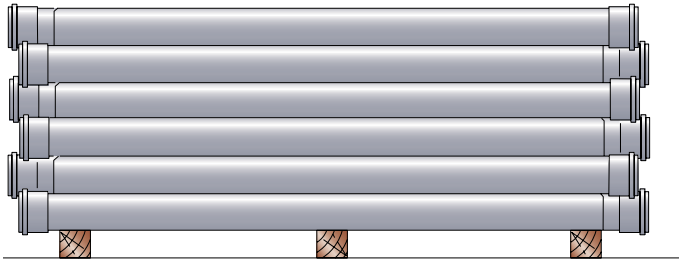

Soil & Waste – Stack Design Considerations

Typical UK design - single soil & vent pipe (SVP)

- Ø110mm vertical soil stack with direct connections for:
 - Ø110mm soil pipe branch for WC
 - Ø32 waste pipe for washbasin
 - Ø40mm waste pipe bath and ground floor
 - Ø40mm waste pipe for kitchen sink
- Vented to atmosphere through roof Ø110mm connection to underground drainage system
- Design to British Standard BS 12056

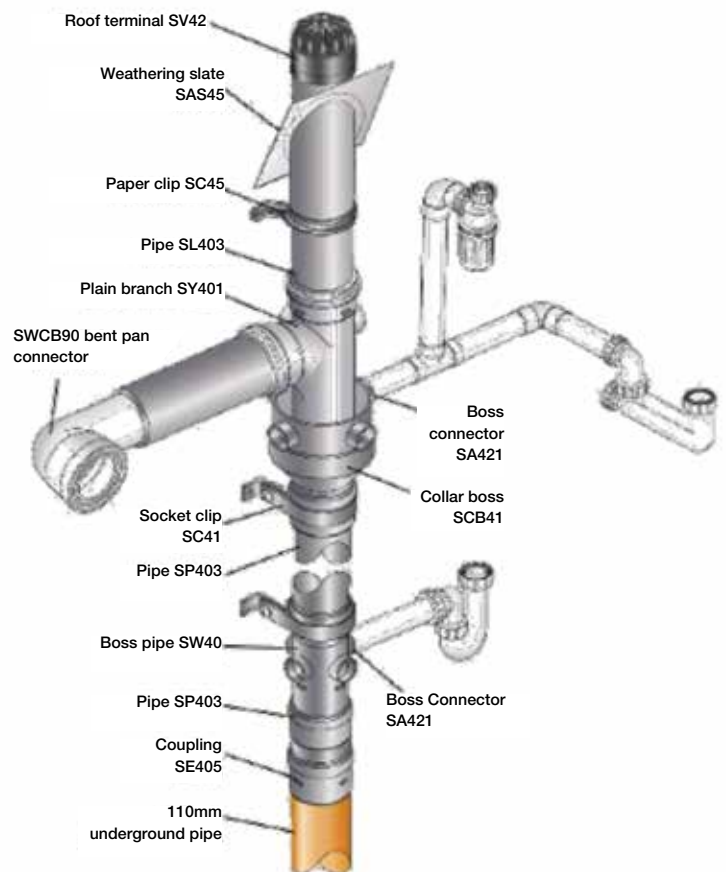

Two pipe soil and vent system

- Separate Ø110mm vertical soil pipe for WC pan branch connection
- Separate Ø110mm vertical soil pipe for Ø82mm branch connection waste pipe to bathroom and kitchen via trapped floor gully
- Vented to atmosphere through roof
- Clean-outs used on horizontal pipe runs and each floor level
- Design common to Asian markets

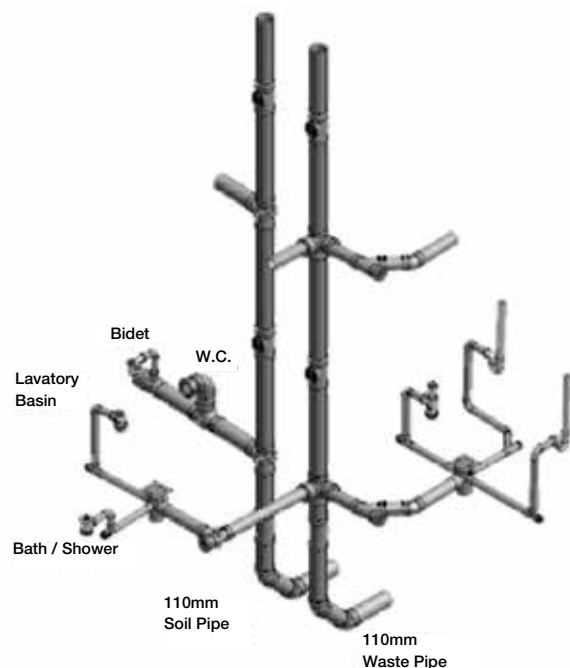

Typical Middle East soil & waste layout

Shown below is a typical bathroom installation using Marley Plumbing & Drainage products. The installation consists of a separate soil and waste stack, which may not be required in all applications where one stack will suffice.

This diagram shows a range of ways of connecting waste to a soil stack and the typical connections to appliances.

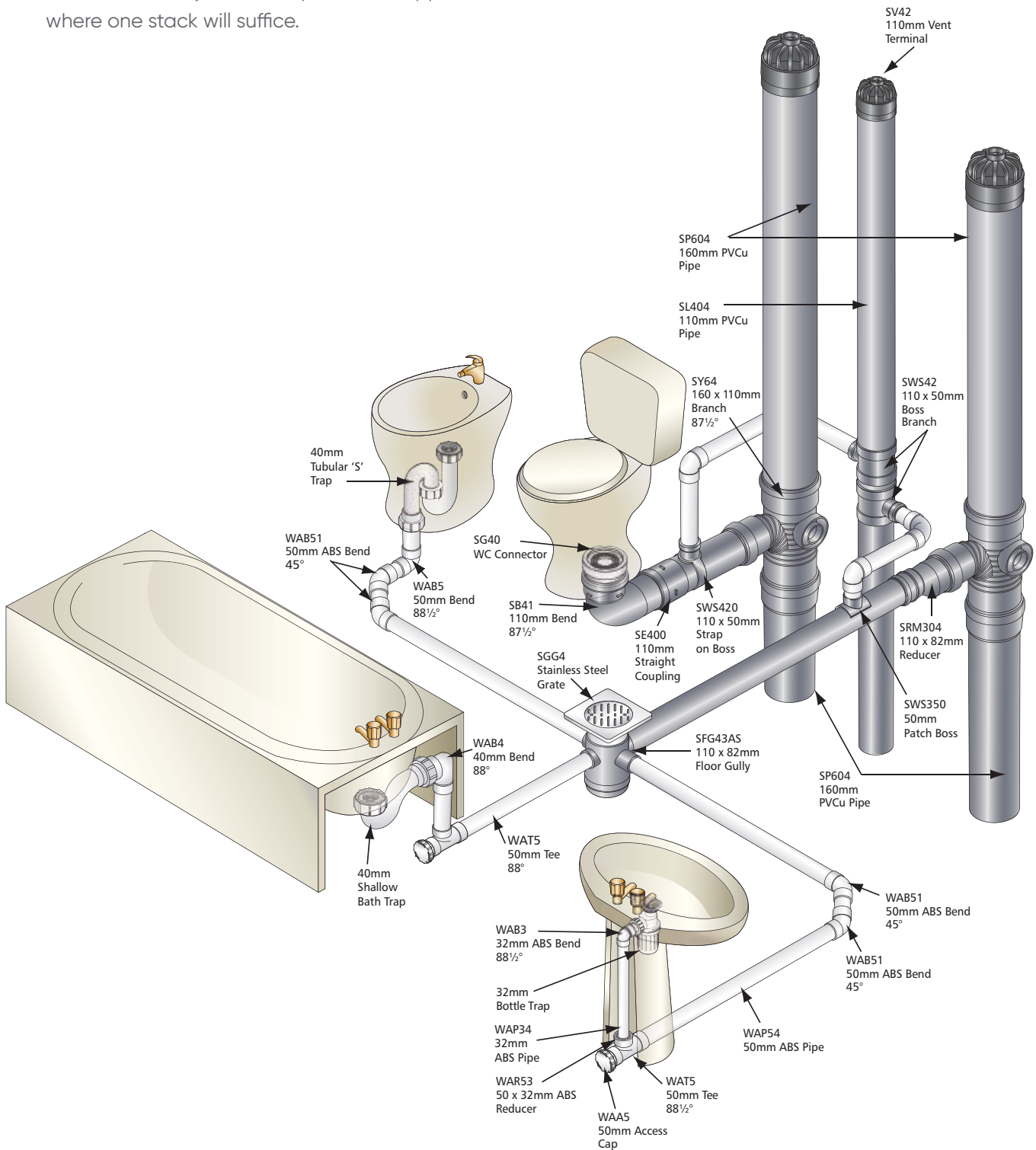

Branches at the base of soil stacks

For single dwellings up to three storeys high, the distance between the centre line of the lowest branch connection and the invert of the drain should be at least 450mm. For multi-storey systems up to five storeys high, the minimum distance should be 740mm, up to twenty storeys; a separate drain connection is required to level one. Over twenty storeys, levels one and two require a separate drain connection.

Over twenty storeys level one and two to separate drain connection



Offsets in stacks

Offsets in the wet portion of a discharge stack should be avoided wherever possible but where they have to be fitted a large radius or two 45° bends should be used to create each change of direction.

Offsets in lightly loaded stacks up to three storeys high do not require offset venting but on multi-storey buildings this may be necessary depending on the loading of the stack and the numbers of floors above the offset. The principles previously described for bends and branches at the base of a stack should also be applied.

This diagram shows a range of ways of connecting waste to a soil stack and the typical connections to appliances.

Stub waste

This technique is often used to connect isolated ground floor waste appliances such as basins, baths, shower trays and sinks to eliminate exposed pipework or low level ducting. The 110mm unventilated PVCu drain is terminated at finished floor level with a reducer and boss adaptor to suit the size of waste from the appliance.

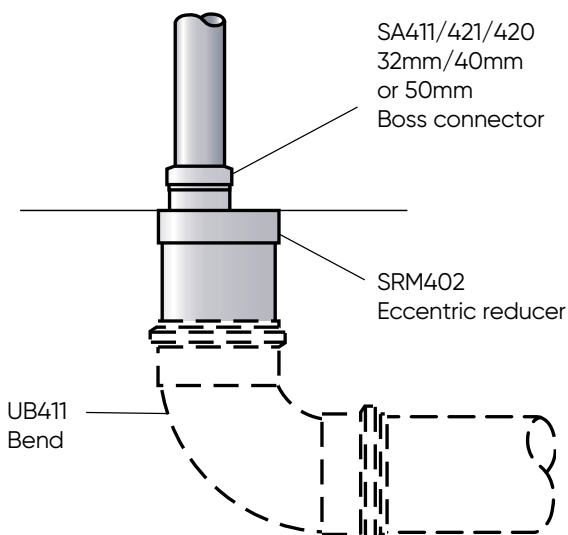

Base of a vertical soil & vent pipe

Min. Height	Application: Building Height
450mm	Up to 3 floors (single dwelling)
740mm	Up to 5 floors
One Floor	More than 5 floors
Two Floors	More than 20 floors

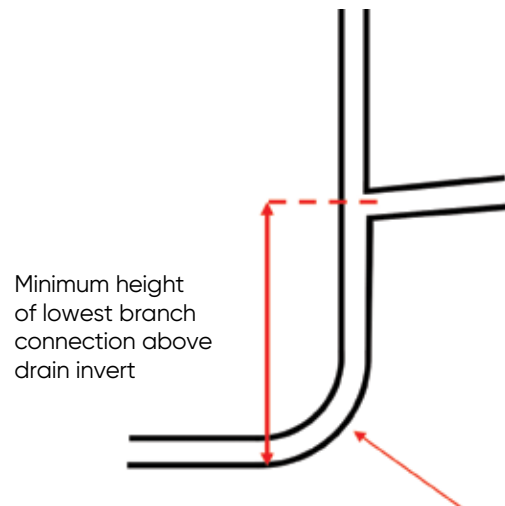

- Use a long radius bend with min radius $R = 200\text{mm}$
- Or use two 45° bends with a short piece of pipe

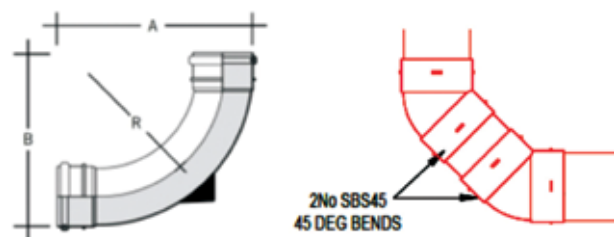

Stub stacks

An unventilated stub stack terminated with an access fitting may be used to connect a group of ground floor appliances to the building drain provided the vertical drop to the invert level of the drain does not exceed 1.5m from a WC and 2.5m from a waste appliance.

Where one or more stub stacks are connected to the same drain, the head of the run should be ventilated to atmosphere or air admittance valves fitted to each stub stack arrangement.

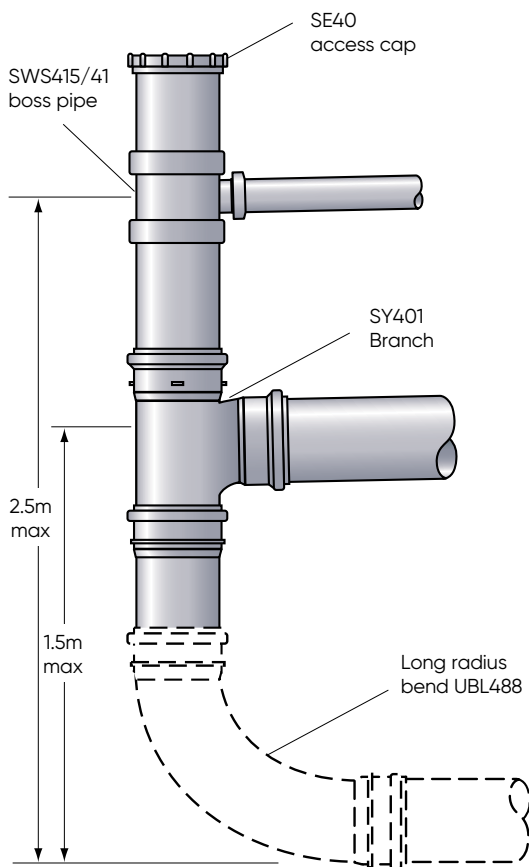

Collar Boss

The Marley Collar Boss was specifically designed to overcome installation problems imposed by the 200mm restricted zone and to allow multiple low level bath or shower waste pipes to be connected to the stack above floor level.

Cross-flow is prevented as the circular annular chamber protects the small diameter waste connections from the WC discharge allowing waste water to flow freely and merge below the critical zone.

Different combinations of 110mm branches can be used with the collar boss to accommodate various WC positions which may be up to 3 meters from the vertical stack.

8-way collar boss

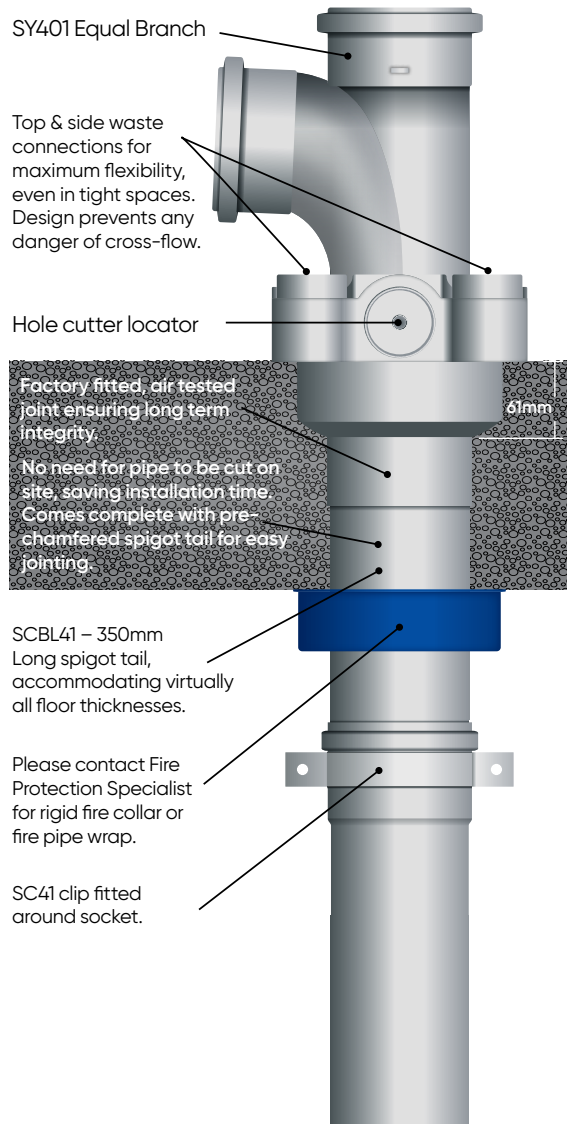

Prevention of Cross-flow

Where small diameter branch waste pipes connect to a discharge stack they must be arranged to eliminate the risk of cross-flow from one branch to the other. A branch creates a no entry zone for opposing waste connections, which varies depending on the stack diameter. No connections should be made within the restricted zone although entry is permissible on the centre line of the boundary directly opposite or at right angles.

To prevent cross-flow from a large diameter branch to a smaller waste connection, the latter should be made to the stack at or above the centre line of the larger branch, at right angles or at least 200mm below the restricted zone. Entry is permissible on the boundary centre line directly opposite or at right angles.

Stack size (mm)	Height of zone 'H' (mm)
82	90
110	110
160	250

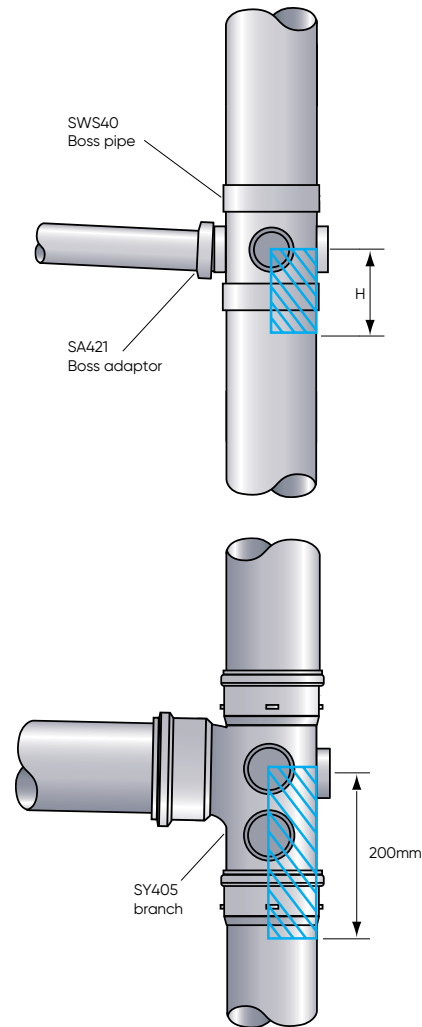

Branch pipe gradients

The gradient of a branch pipe should be uniform and adequate to drain the pipe and appliance efficiently. A minimum gradient of 18mm/metre should be adopted for 32, 40 and 50mm nominal size pipes but larger diameter 82, 110 and 160mm branch runs may be laid flatter at 9mm/metre fall where the discharge flow rate exceeds 2.5 litres/second.

Branch pipe lengths

The following information is taken from Table 6 of BS EN 12056: 2: 2000 and provides general guidance on the recommended lengths of unventilated branch pipes for a variety of sanitary appliances.

Appliances	Dia (mm)	Min.trap seal depth (mm)	Max. length of pipe (m)	Pipe gradient (%)	Max. bends (No.)	Max. drop H (m)
Washbasin or bidet	32	75	1.7	2.2	0	0
Washbasin or bidet	40	75	3.0	1.8 to 4.4	2	0
Bath or shower	40	50	No limit	1.8 to 9.0	No limit	1.5
Bowl urinal	40	75	3.0	1.8 to 9.0	No limit	1.5
Trough urinal	50	75	3.0	1.8 to 9.0	No limit	1.5
Kitchen sink	40	75	No limit	1.8 to 9.0	No limit	1.5
Dishwasher or washing machine	40	75	3.0	1.8 to 4.4	No limit	1.5
WC	110	50	No limit	1.8 min	No limit	1.5

The maximum lengths given above may be increased where the branch pipe is ventilated or an air admittance valve is used. For further details refer to the above standard.

Ventilation of Soil stacks

Fundamentally, an efficient drainage system design is about managing the mix of air and water. More precisely, it is about managing the air pressure regime within the boundaries that maintain a water seal in the trap. Marley offer 3 different product solutions to manage this.

1. Secondary Ventilation

Traditional drainage design incorporates the installation of a secondary ventilation stack and branch pipework system alongside the main soil and waste stacks to ensure this air pressure is maintained.

	Stack size (mm)	Secondary vent (mm)	Maximum capacity (l/s Swept entries)
Primary ventilated stack	82	–	2.6
	110	–	5.2
	160	–	12.4
Secondary ventilated stack	82	50	3.4
	110	50	7.3
	160	80	18.3

Soil stack capacity

The capacity of a soil stack can be increased by the installation of a secondary ventilated stack. The following information is taken from tables 11 & 12 of BS EN 12056-2: 2000 which illustrates this increase.

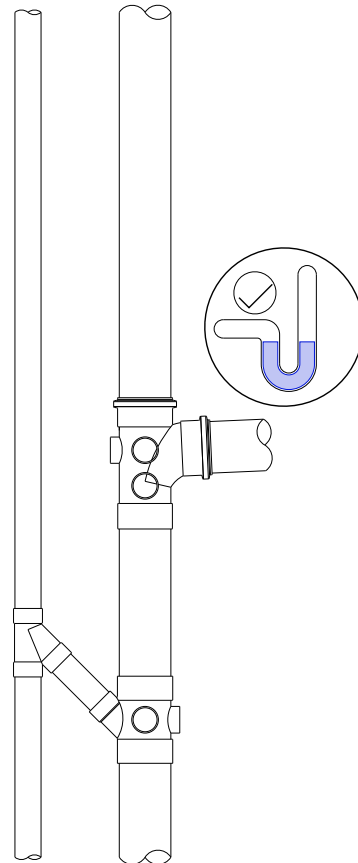

2. Active Drainage Ventilation

An active ventilated system provides relief at the Point Of Need (PON) by removing or attenuating an incoming pressure transient that, if left, could lead to trap seal depletion.

The single stack solution with the Studor P.A.P.A. and AAVs is ideal for high-rise applications, eliminating the need for roof penetrations.

The combination of the P.A.P.A., Maxi-Vent and Mini-Vent air admittance valves support a complete system to limit pressure fluctuations, guaranteeing the integrity of the traps.

Stack size (mm)	Maximum capacity (l/s)
110	7.3
160	18.3

Benefits of single stack with P.A.P.A system:

- Provides effective protection against positive/negative pressures in the drainage system
- Scientifically proven and tested for total peace of mind
- Reduces installed service space, slab & roof penetrations and passive fire protection measures

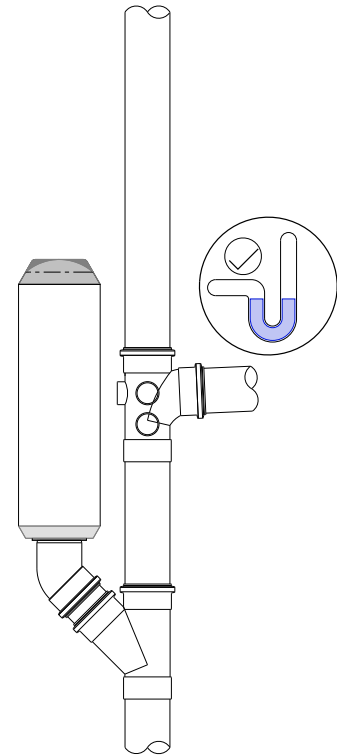

Maximum drainage flow for P.A.P.A. is illustrated alongside.

Air Admittance Valve

Installation guide for a row of 3 storey houses

First 4 houses: Can use AAV inside all homes

5 to 10 houses: One open vent required at head of drain - all others use AAV's

11 to 20 houses: Open vent head of drain and mid-point - all others use AAV's

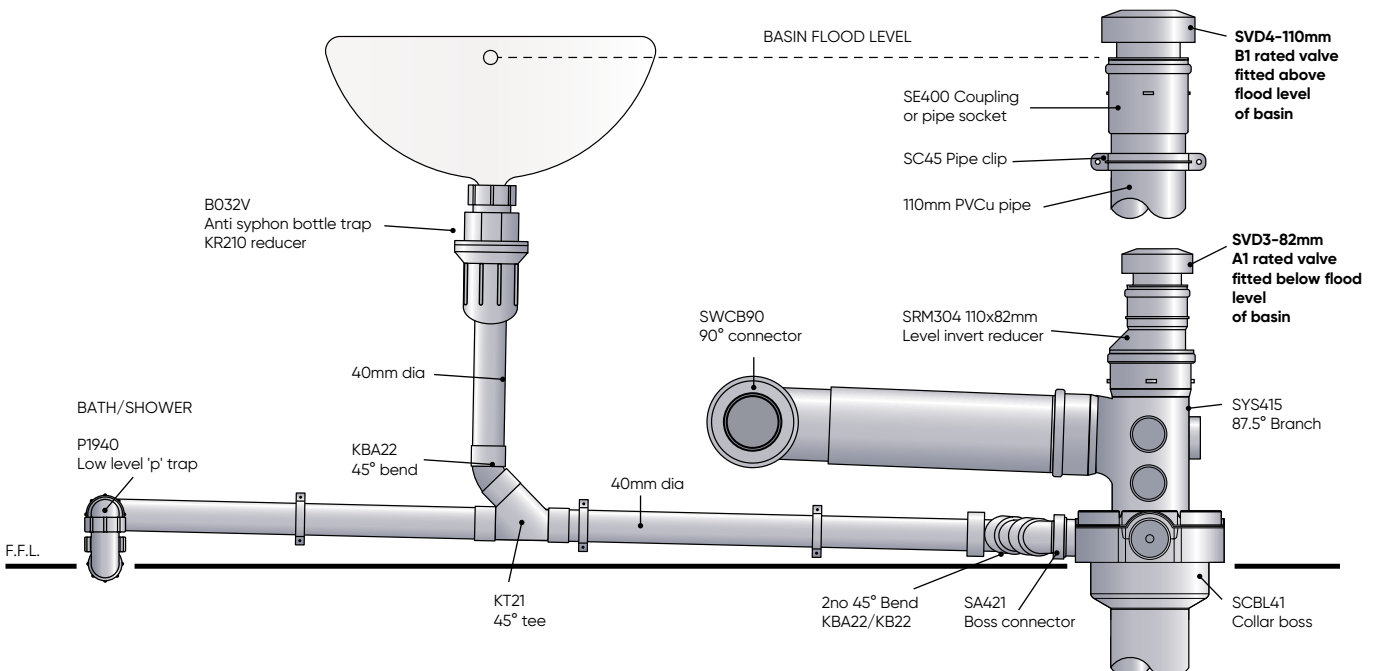

Soil & Waste – Joining Guide

Typical Pipe cutting and jointing

Pipe Cutting Guide (See Figure 1)

- Cut pipe cleanly with square edge with a fine tooth hand saw
- Chamfer 45 degrees for 2/3 wall thickness of pipe, using a medium file or rasp
- This is essential to ensure that the sealing ring is not displaced during insertion.

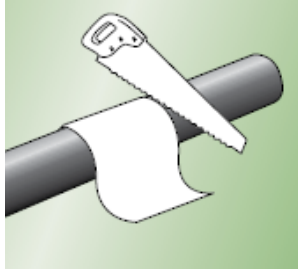

Figure 1.

Steps:

- Push-fit ring seal joints requires a 45° chamfer angle on the pipe edge
- Ensure the sealing ring is properly placed in the socket of the fitting
- Lubricate evenly around the pipe using only Silicone based lubricant to lubricate the joint
- Align correctly the components to be joined, push pipe or fitting into the socket
- Ensure that the expansion gap is maintained: 10mm expansion gap required every 6 meters
- Ring seal joints can be leak tested immediately

Push-fit Jointing Guide (See Figure 2)

The ring seal has been successfully employed as the principal method of jointing large diameter PVCu pipes and fittings since their introduction over thirty years ago. This particular technique has proved extremely reliable as the joint can accommodate thermal movement that will occur as a result of temperature variations. An expansion gap of between 5-10mm should be allowed within each ring seal socket as each full length of pipe is installed and fixed using socket and barrel pipe clips.

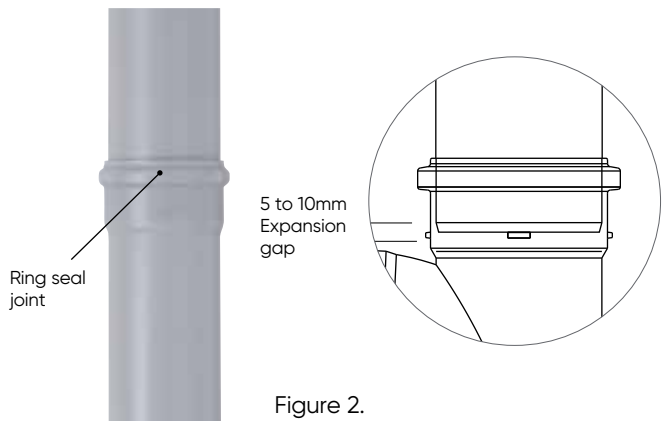

Figure 2.

Solvent Jointing Guide

Solvent weld jointing is also widely used and many components in the range are available with this facility to provide an effective alternative.

Steps:

- Insert straight cut pipe into socket (Solvent weld sockets do not need a chamfer angle)
- Mark the insertion depth on the pipe
- Remove the pipe add a liberal help of Marley Cement solvent weld in the socket and on the pipe
- Insert the pipe with a twisting action

Solvent cement fuses the two contact surfaces to make one homogenous joint and sets in 90 seconds.

Solvent weld joints are fixed and do not allow thermal expansion and cannot be tested for 24 hours. Ring seal joints must be incorporated to control thermal movement.

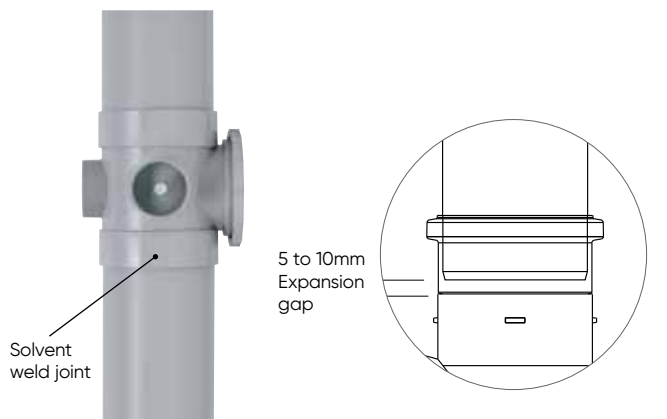

Floor gully

Trapped floor gullies are suitable for use as a shower outlet in bathrooms, wet rooms or as floor gullies for washdown areas in domestic, public and commercial buildings. The floor gully either has a 50mm or 82.4mm outlet, with three waste pipe inlets. The

SFG42AS and SFG43AS provide a minimum 75mm water seal. The fitting is supplied with a loose base so that the body height can be reduced for casting in a shallow slab. A stainless steel grating, SGG4 or PVCu grating, are available.

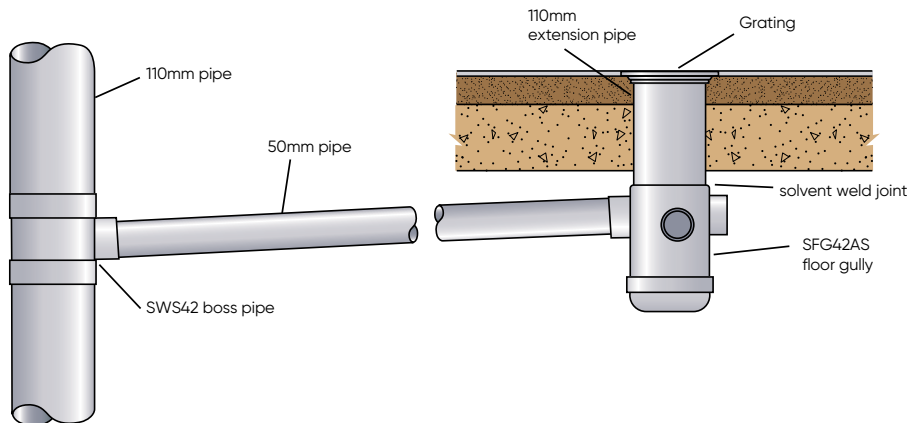

System connections

Boss branches

The Marley range of boss branches are designed to allow multiple waste pipe connections to be made to the discharge stack from different directions. Four different side entry combinations are possible together with a rear if required. Staggered waste pipe connections, directly opposite are not permitted as cross-flow could occur.

Compatibility

Boss pipes, boss connectors and strap-on bosses fitted with multi-fit 'T' ring seals are suitable for use with PVCc or ABS waste systems to BS EN 1566 or BS EN 1455-1, polypropylene to BS EN 1451-1 and metric size copper to BS EN 16090.

Un-perforated boss upstands on boss pipes, branches and reducers may be drilled to accept 32, 40 and 50mm boss connectors SA411, SA421 and SA420 using a 51mm diameter hole saw. Knuckle bends KBK25 and KBK35 may also be used as 90° boss connectors for 40 and 50mm PVCc or ABS waste pipework.

Horizontal connections

The SWS4135 boss pipe is recommended for use in horizontal situations where connections to 110mm diameter pipe is made at 45°. This fitting has a 50mm solvent weld socket to accept PVCc or ABS waste pipes.

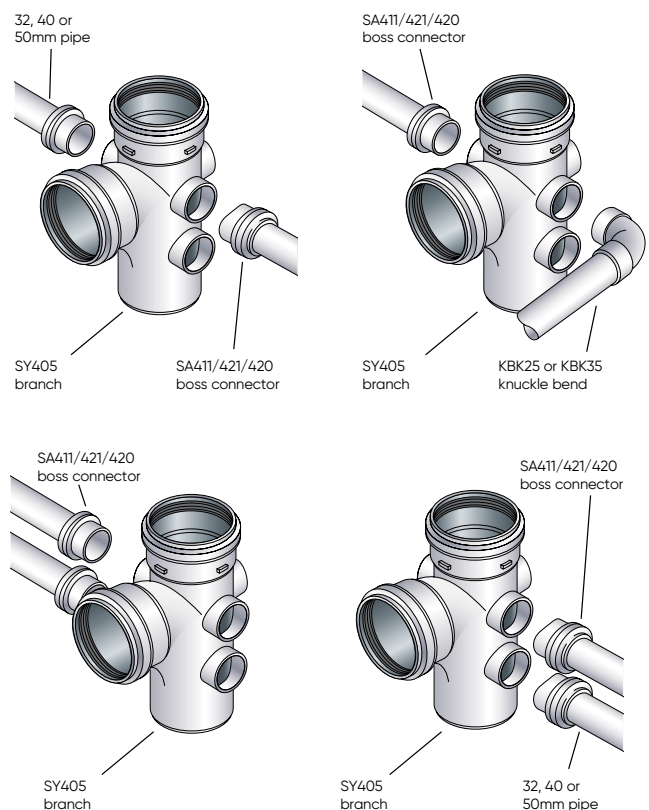

Boss pipe connections

Four different types of fitting are available to provide alternative methods of connecting small diameter waste pipes to 82, 110 and 160mm vertical discharge stacks.

Single boss pipes

Available with ring seal or solvent weld sockets for push-fit or solvent weld jointing, single boss pipes allow 32, 40 and 50mm waste pipe connections to be made at 87½° direct to the vertical stack.

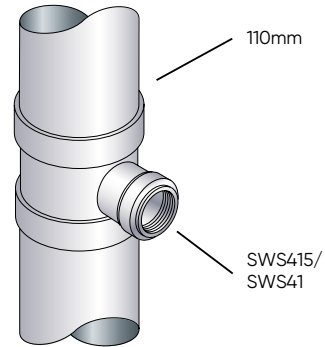

Multiple entry boss pipes

Supplied in ring seal or solvent weld options, all have 90° boss upstands moulded on each fitting with one inlet port open. Connection is made using the appropriate size Marley boss connector to suit 32, 40 or 50mm waste pipes.

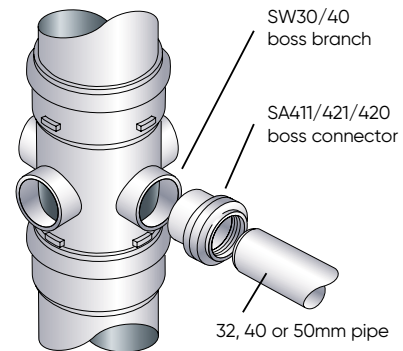

Patch bosses

Suitable for solvent weld jointing to new and existing 82mm diameter PVCu discharge stacks to accept 32, 40 and 50mm size PVCc or ABS waste pipework.

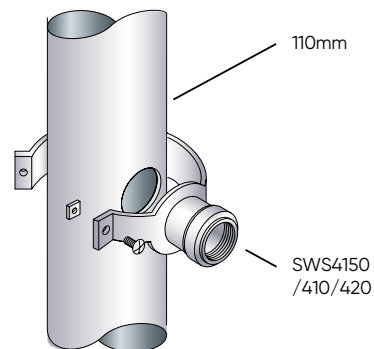

Strap-on-bosses

Primarily designed to permit 32, 40 and 50mm waste pipe connections to be made to existing 110mm PVCu discharge stacks, strap-on-bosses can also be used on new systems to provide flexibility of installation during different stages of construction.

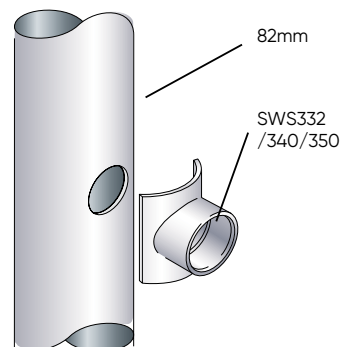

Soil & Waste – Pipe Support

Pipe Support

The Marley pipe support range was developed to meet the specific requirements of uPVC suspended sanitary pipework and drainage systems. Manufactured in zinc electro plated mild steel for internal use, the versatile range of components can be assembled to provide a robust, lightweight system suitable for most applications. The system also provides suitable control of expansion and contraction.

Experience has proved that an efficient and reliable uPVC sanitary pipework system depends considerably on the attention that is placed on the correct provision of **pipe support brackets**. This is particularly important in multi-storey buildings where care must be taken to ensure clips are positioned to control thermal movement at each floor level.

The arrangements of brackets and channel supports have been extensively tested and the assembly techniques used have been successfully employed on many domestic and commercial installations.

Single support

Recommended for waste or larger diameter pipework fixed within 500mm of the floor soffit.

Double support

Developed for use with larger diameter pipework fixed within 1.0m of the floor soffit.

Pipe brackets

The 110mm two piece pipe brackets are designed to fit round the ring seal socket of a pipe or fitting. Where intermediate support brackets are located, the SC621 PVC barrel clip collar is used as a spacer sleeve between the pipe and bracket.

Angle and side bracing

Angle braces should be provided at 6m centres to prevent lineal and thermal movement. Side bracing may also be necessary on long runs where there are no side connections to eliminate lateral movement.

Vertical pipes

The transition between vertical and horizontal pipework should be achieved using two 45° bends or a single 87½° long radius bend with a support bracket positioned as close as possible.

Branch connections

All branch connections into horizontal pipework should be made at 45° to ensure the discharge is swept in the direction of flow.

Structural fixings

It is recommended that 6mm rawlbolt or similar proprietary fixings are used to secure base plate and angle cleats to the structure.

Support brackets for vertical soil pipes

Plastic coated metal socket clips are designed to fit ring seal sockets and act as anchor brackets. These used in conjunction with uPVC intermediate pipe clips, control expansion and contraction and maintain the vertical alignment of the stack.

Material	BS Pipe Ø	Vertical Support Max
PVC-U	Ø82mm	Every 2.00m
PVC-U	Ø110mm	Every 2.00m
PVC-U	Ø160mm	Every 2.00m

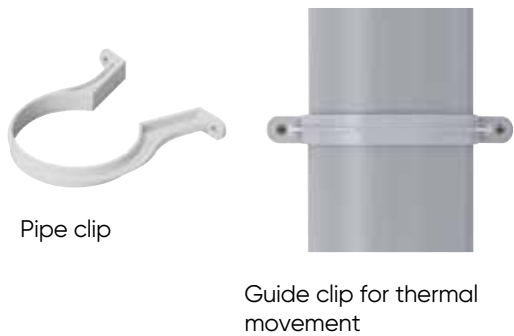
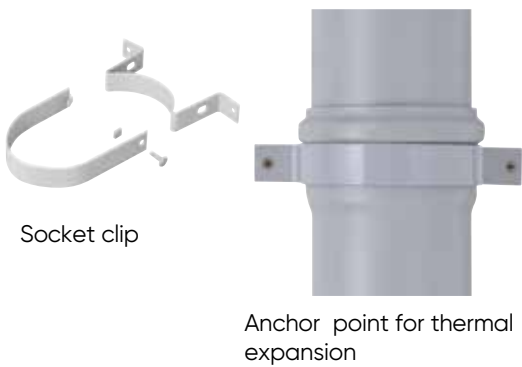

Support Brackets for Suspended Pipework

When suspending drainage with threaded rods (usually M10) drops should not exceed 300mm. Side bracing will be required on the expansion joints.

Important: Setting out the gradient fall line

Pipe Ø	Min Gradient	Pipe Support
Ø82mm	18mm / m	Every 1.0m
Ø110mm	18mm / m	Every 1.0m
Ø160mm	18mm / m	Every 1.2m

Single support

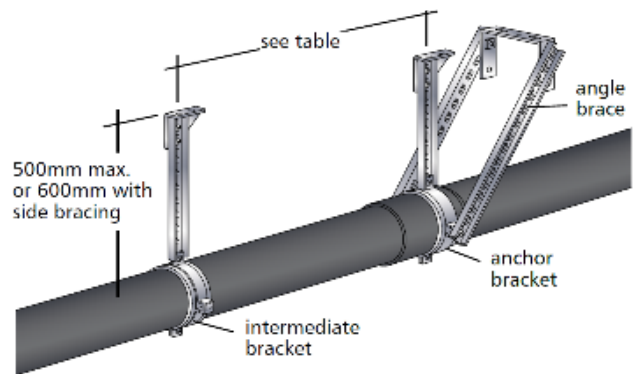

Double support

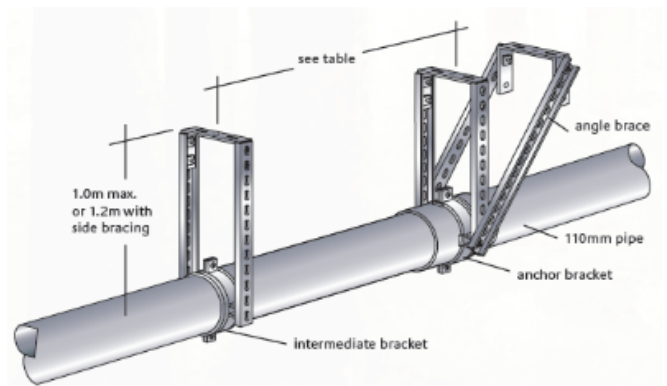

The above images show best practice with suspended pipework. When installing suspended pipework with non-Marley clamps and fixings, please ensure that while fittings are clamped (bracket tight), pipes should only be supported (bracket should allow for pipe to move within the bracket) to allow for thermal movement / expansion.

Waste Pipe: Support brackets and pipe gradient

Saddle pipe clip for waste pipes

Ø32, Ø40, Ø50



Material	Pipe Size	Horizontal Pipe Clips	Minimum Gradient	Vertical Pipe Clip Distance
MuPVC	Ø32, 40, 50	500mm	20mm / m	1.0m

Soil & Waste – WC Connectors, manifold & traps Guide

WC connections

Two different types of connectors are available to allow connection to vitreous china or stainless steel WC pans, slop hoppers and other similar sanitary equipment. Manufactured in PVC and eva (ethylene vinyl acetate) to accommodate a range of outlet sizes between 84 and 110mm sanitary pipework or underground drainage.

The 90° ST40W, ST41W and SG40W connectors are supplied complete with flexible seal and retaining cap. Where the SGS41W or STS41W pan connectors are used, the WC socket must be trimmed to suit the length of pan spigot before the SA323W is solvent welded in position. Ground floor toilets often have their own connection to the building drain to eliminate pipework and ducting. Where this occurs both types of connector are suitable for push-fit or solvent weld jointing to the 110mm PVCu drain.

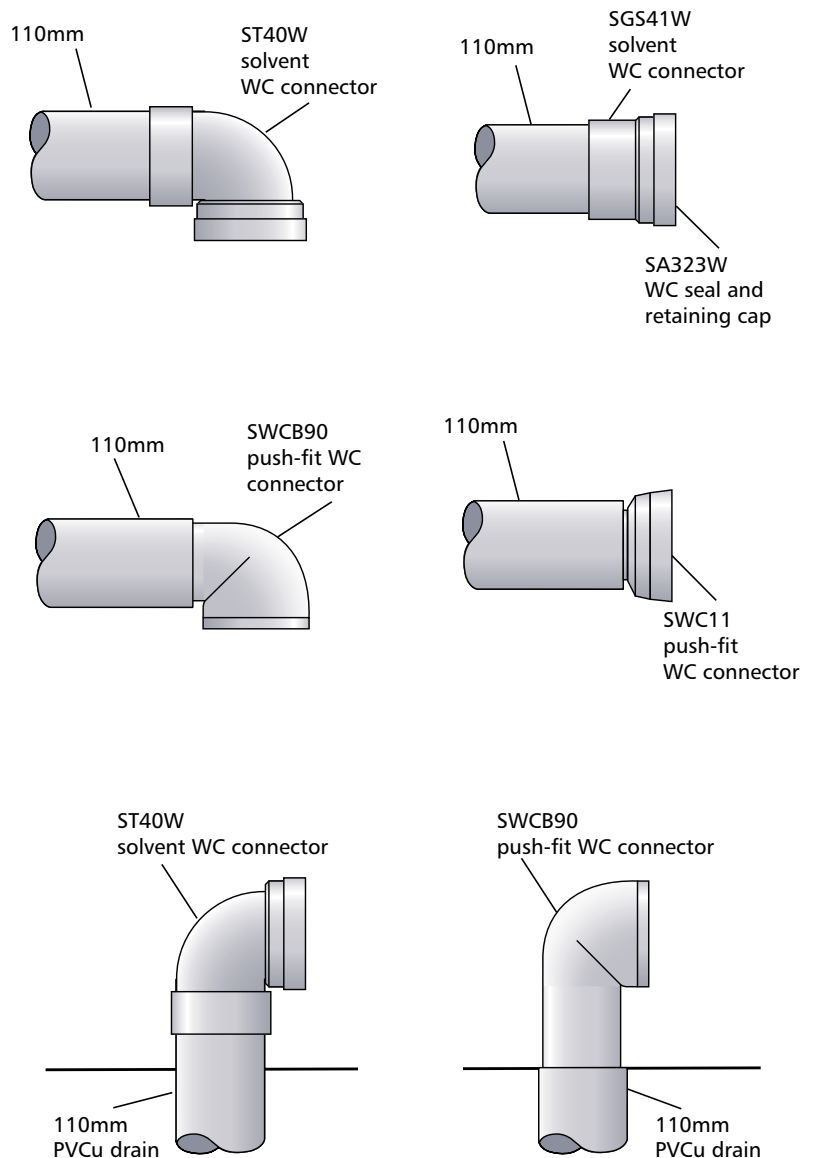

Combined Branch Waste

A combined branch waste is often used to connect a bath and/or shower and basin to the discharge stack as this allows waste pipework to be neatly concealed in a low level duct. Where this technique is adopted a 45° entry tee must be used to ensure the basin discharge is swept in the direction of flow towards the stack. The minimum distance between the bath or shower and basin connection should not be less than 500mm and it is recommended

that an anti-syphon bottle trap is fitted to the basin or a vent provided to protect the appliance from self-syphonage.

It is recommended that the distance of the combined waste does not exceed 3 metres, however, experience has shown that longer runs using 40 or 50mm pipework has proved successful provided adequate fall can be obtained to ensure self-cleansing velocity is maintained.

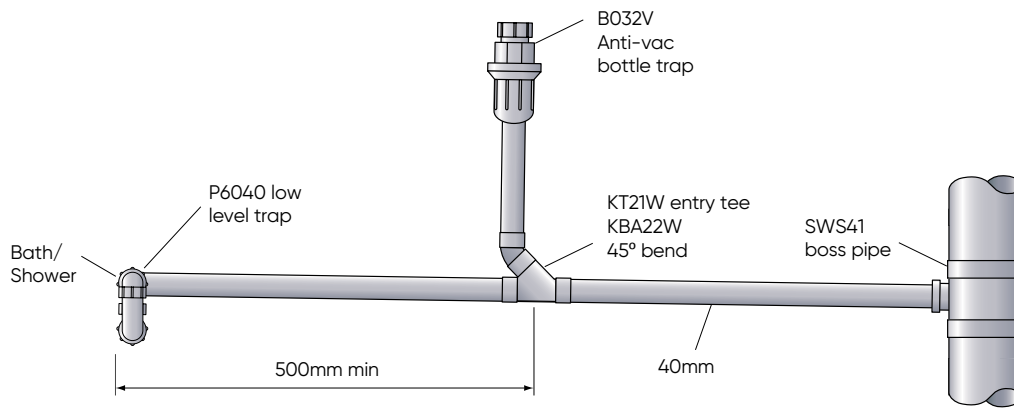

WC Manifold System

Developed for use in sanitary pipework systems in schools, hospitals, public and commercial buildings, the manifold system allows ranges of toilets to be connected to a horizontal float above floor level and eliminate the need for specially fabricated fittings.

The components are suitable for installation in a duct, or for fitting on the surface of the wall directly behind the pan. Where the manifold is fitted directly behind the range of toilets, the minimum distance between the end of the WC spigot and the face of the wall is 150mm. To facilitate varying angles and gradients the 110 x 90mm manifold branch has a radial socket to match both options of adjustable WC bend. When the selected bend is cut to the appropriate line and solvent welded into

the socket on the manifold branch a uniform fall is obtained between each toilet on the horizontal float.

To accommodate different dimensions between the WC spigot and horizontal float, the adjustable spigot bend SM43W may be trimmed by up to 35mm or the extension pipe SM45W can be used with the pan connector SM44W and SA323W cap & seal.

The WC socket on both the SM42W and SM44W must be trimmed to suit the length of pan spigot before the SA323W is fitted.

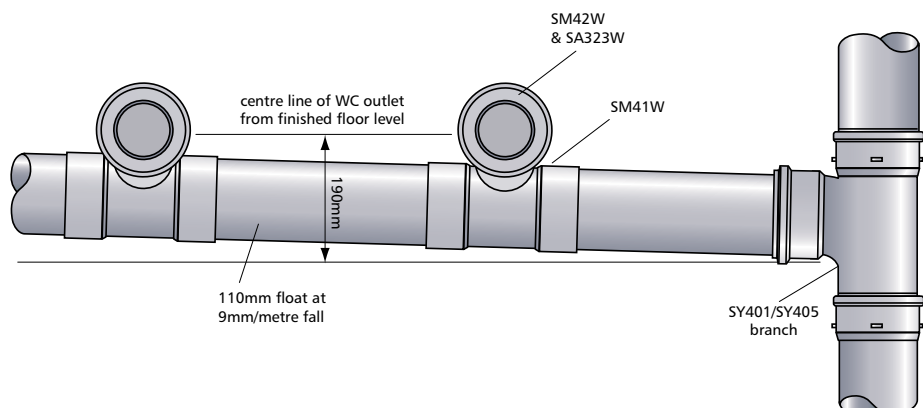

WC Manifold System

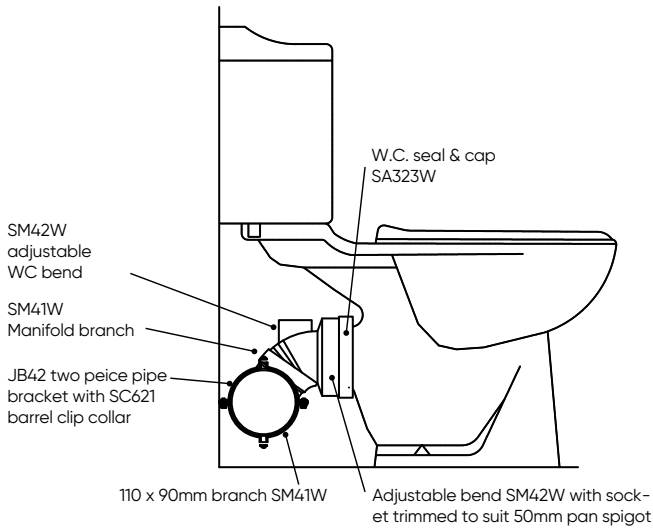

Manifold branch SM41W with SM42W

Cut line	50°	55°	60°	65°	70°	75°	80°	85°	90°
A – projection (mm)	93	93	92	91	90	87	84	80	75
B – drop (mm)	69	77	85	93	101	109	116	123	130

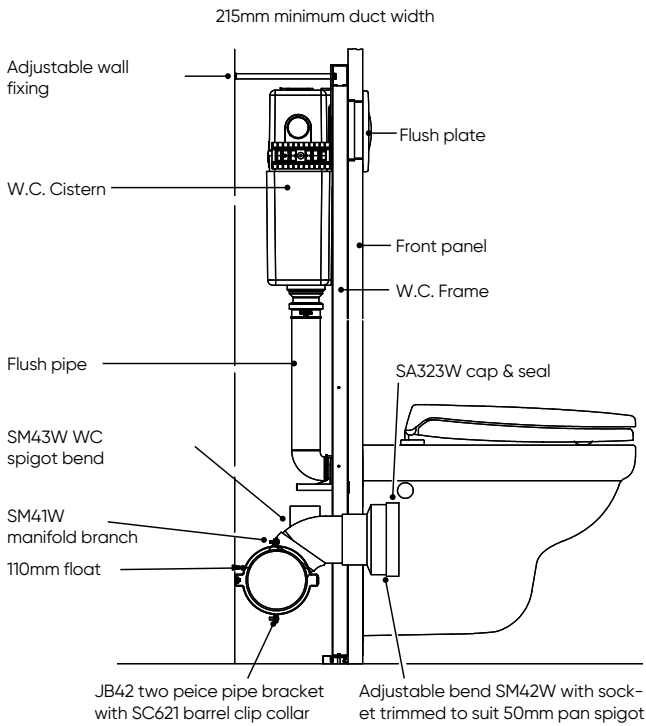
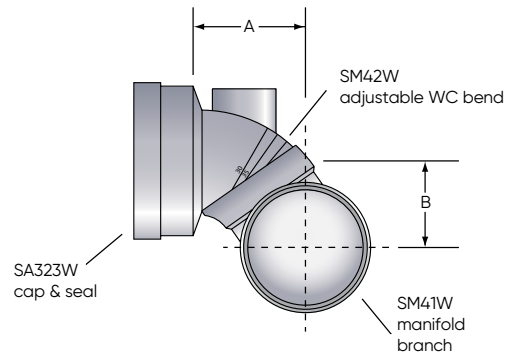

Manifold branch SM41W with SM43W

Cut line	50°	55°	60°	65°	70°	75°	80°	85°	90°
A – projection (mm)	180	180	179	178	177	174	171	167	162
B – drop (mm)	69	77	85	93	101	109	116	123	130

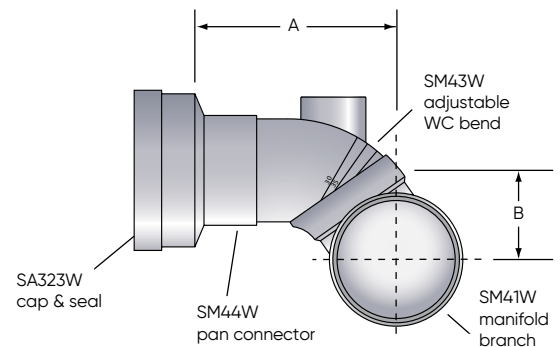

WC Manifold System

Up to six WCs can be connected to a soil stack using the WC manifold system and a single branch connection. By using a double branch connection, an additional six WCs can be connected. The table, right, details the angles of the manifolds for this installation.

NUMBER OF WCs	Angle of Manifold Branch					
	WC 1	WC 2	WC 3	WC 4	WC 5	WC 6
6	80°	75°	70°	65°	60°	55°
5	75°	70°	65°	60°	55°	
4	70°	65°	60°	55°		
3	65°	60°	55°			
2	60°	55°				

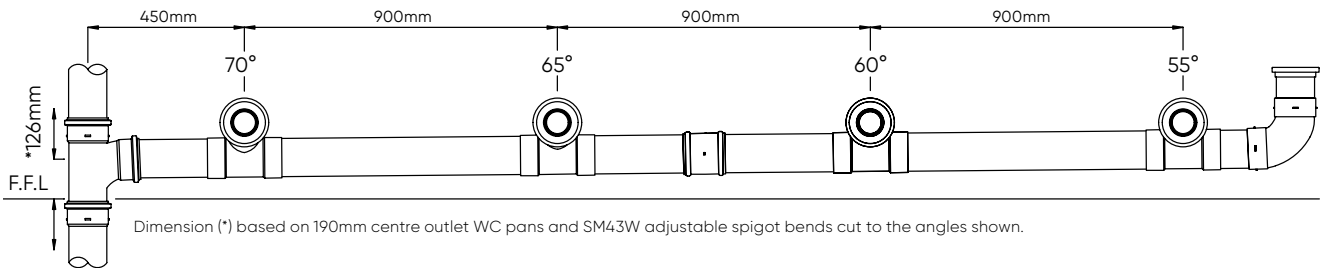

1. Select the adjustable bend angle required from the above diagram according to the WC position. Cut the bend with a hacksaw, removing the unwanted portion.

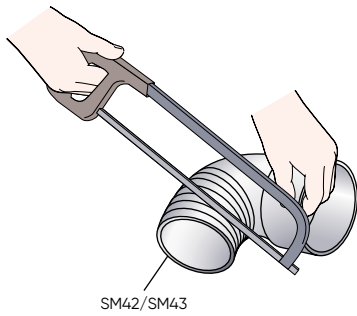

2. File away any rough edges from the face of the fitting and wipe clean the bend and branch, with a dry cloth. Before joining, the bend and branch should be checked for position and alignment, both parts being marked to ensure accurate assembly.

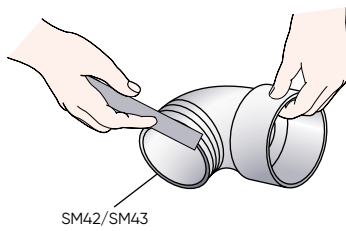

3. Apply a uniform coat of Marley solvent cement, to the short branch radial socket and to the external surface of the bend body.

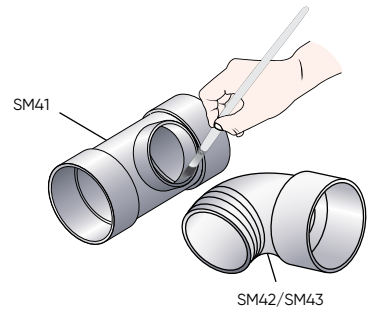

4. Assemble the branch immediately, insuring that the marked lines on the fitting coincide. Do not twist the two parts of the branch during this operation, but maintain steady pressure until the spigot of the bend comes to rest against the internal surface of the branch socket. Quickly wipe off any surplus solvent cement from the inside and outside of the completed joint and hold in position for approximately 15 seconds.

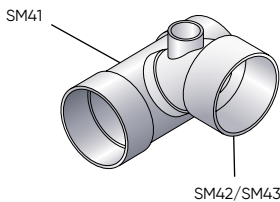

5. Trim the WC socket to suit the toilet pan spigot length and remove any swarf with a file. Place the seal in the socket, apply a uniform coat of solvent cement about 15mm wide to the outside of the socket and inside the retaining cap. Push onto the socket and wipe off any surplus solvent cement.

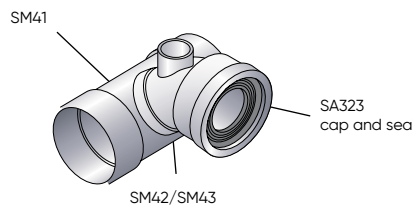

To accommodate varying dimensions between the WC spigot and the centre line of the horizontal pipe run, the adjustable spigot bend SM43 or extension pipe SM45 can be used with WC connector SM44.

WC Connectors Installation Guidelines

Our comprehensive range is one of the largest on the market, and covers spigots of 74mm – 114mm, ensuring an accurate fit, regardless of the make and model of sanitary chinaware.

Selecting the right WC connector

Measure the OUTER diameter of your spigot.



Measure the INNER diameter of your pipe.



Then take a look at the dimensions provided for the individual connectors to find the best matches.

Know your WC pan spigot

Key	Size	Pipe Suitability	British Standard
PAGE: 24 – 28	97-108 mm	Modern & New Pans	BS 5503 & BS 5504
PAGE: 29	108-114 mm	Old & Syphonic Pans	BS 1213
PAGE: 30 – 31	76-95 mm	Stainless Steel Pans	–

Know your pipe

Key	Size	Pipe Suitability	British Standard
STANDARD ①	99-105 mm	uPVC / Clay / Cast Iron	BS 4514/BS 4660/BS 65/BS 416
CAST IRON ②	88-92 mm	Traditional Cast Iron	–
OLD ③	74-77 mm	–	–
COPPER ④	105-108 mm	Copper	–

All WC connectors are made to fit pans conforming to BS 5503 and BS 5504, including ones with bosses.

Sealing flanges

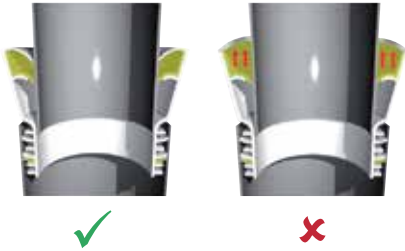

When connecting a WC connector to the pan spigot, the sealing flanges must be pushed inside with the pipe.

Don't pull the other sealing flange out over the top of the pan spigot – it may lead to leaks.



MKS1 vs **MKS2**

It's easy to get it right!

When you install a new toilet, in a new build development, you should use a MKS2 WC connector. When you refurbish an old toilet, you need to use a MKS1 WC connector (see page 69).

Use MKS1 on an installation, where it's been DONE!

Use MKS2 on an installation, where it's all NEW!

Make sure you know your pans and spigots

Pan dimensions

- 97 – 108mm Modern Pans
- 108 – 114mm Old Pans
- 76 – 96mm Stainless Steel

Spigot sizes

- ❶ 99 – 105mm Standard
- ❷ 88 – 92mm Cast Iron
- ❸ 74 – 77mm Old
- ❹ 105 – 108mm Copper

Multilink

Multilink is a unique fitting which sleeves the fins of all 99 – 105mm outlet Multikwik pan connectors.

Enabling direct connection to be made to the inlet of another pan connector.



Space Saver Bend

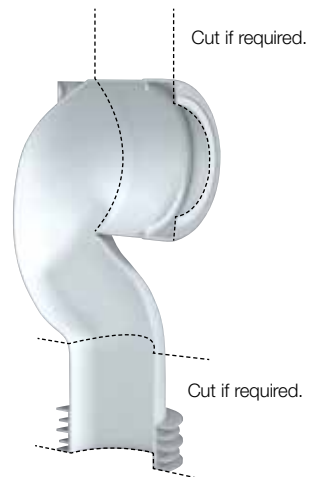

Soil Pipe Extensions

Available for 4", 3½" and 3" a Multikwik Soil Pipe Extension can be cut to required length, removing the unsightly existing pipe within the bathroom.

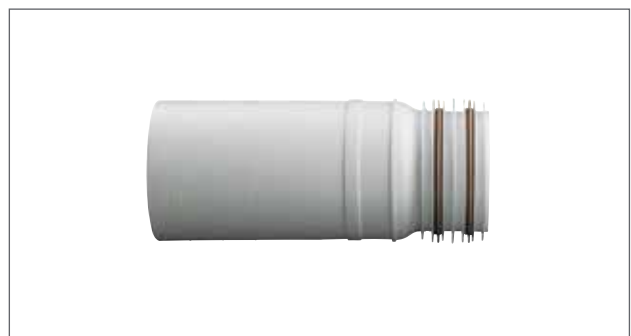

Traps Guidelines

Multifit Nut & Seal

All Multikwik traps have a multifit nut and seal that allow connection to push fit, solvent and copper pipes. The thumb recesses make it easy to tighten, even with wet hands to ensure a 'fit and forget' installation every time!



Water Seal

BS EN 12056-2:2000 states that traps which discharge to a soil stack should have a 75mm seal. Other seal depths can be installed, if installation with required seal depth isn't possible due to size restrictions.

- 50mm water seal traps can be fitted to baths, shower trays and basins with spray taps and no plugs.
- 38mm water seal traps can be used on ground floors when connecting to flat bottomed appliances that discharge to a back inlet gully.



Resealing trap

1

When syphonic action occurs, air gets drawn through the bypass device, allowing an air break.

2

Once the negative pressure stops, the water goes back and reseals the trap.



Bottle Trap Resealing

The resealing function helps to prevent loss of water. Easily removed and cleaned to ensure 100% reliability.

Multi position outlet

The multi position outlet adjusts 360° for installations where space is at a premium or the pipework is misaligned.



To ensure accuracy and efficiency all Multikwik traps have unique slip ring colours to aid size identification.

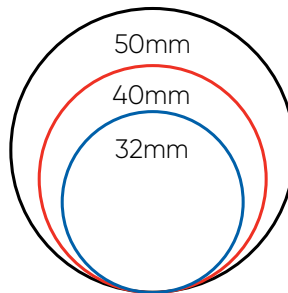

Size guide



Hand basin
Bidet
Drinking fountain
Kitchen appliances



Bath
Shower
Sink
Urinal



Range of basins
Range of urinals
Catering sinks
Hospital appliances





Underground Installation Guide

- Design considerations
- Pipe laying
- Shallow inspections chambers
- Manholes
- Gully combinations
- Transitions to other systems
- Underground installation
- Storage & safety

Underground Design Considerations

Design Considerations

The following standards deal with drainage design:

- BS EN 752: Drain and sewer systems outside buildings.
- BS EN 2015: Construction and testing of drains and sewers.

The design and layout of drainage and sewerage systems should comply with The Building Regulations and Water Authority Specification. Reference should also be made to the Sewers for Adoption manual.

The following information is provided only as a general guide to good practice for the design of underground drainage systems. For full details please consult the relevant documents referred to left.

Means of access

Access is required to drainage installations for testing, inspection and removal of debris. Access to drainage allowing rodding in both directions can be provided by inspection chambers, manholes and other access fittings. Rodding eyes provide access for clearance of debris in the direction of flow only and should thus be used in conjunction with an access chamber or manhole at a point downstream.

No part of the drain or sewer should be more than 50m away from a manhole. The distance between points should therefore not exceed 100m.

For full guidance as to provision of access, reference should be made to BS EN 752. The table right details the maximum spacing of the access points as detailed in the above standard.

	To junction/ branch	To access fitting	To inspection chamber	To manhole
From start of external drain		12	22	45
From rodding point	12	12	22	45
From access fitting	12	12	22	45
From inspection chamber	12	22	45	45
From manhole			45	90

Gradients

Foul water drainage systems are generally designed to run at a maximum of three quarters full bore. Pipe gradients should be established such that the velocity does not fall below 0.70 m/s to ensure adequate self-cleansing.

A 110mm foul drain taking the discharge of less than 1 l/s should be laid at a 1:40 (25mm per metre) fall. A foul drain taking the discharge from a minimum of one WC can be laid at 1:80 (12.5mm per metre).

Gullies incorporating in foul water or combined drainage systems must have a 50mm minimum water seal.

The table right is taken from BS EN 752 and provides guidance on minimum gradients for different size drains.

Peak flow (a) litres/second	PVCu pipe size (mm)	Minimum gradient
<1	110	1:40
>1	110	1:80 (b)
	160	1:150 (c)

(a) Peak flow based on probability flow calculation method

(b) Minimum 1 WC

(c) Minimum 5 WCs

Surface water drainage systems may be designed to run full bore.

Physical characteristics

Dimensions and weights

	Material	BS nominal size (mm)	Min	Max	Wall thickness (mm)	Weight kg/metre
Solid Wall	PVCu	110	110.0	110.3	3.2	1.7
		160	160.0	160.4	4.0	3.0

Dimensions and weights

	Material	Nominal size DN/1D (mm)	Mean Internal Diameter (mm)	Nominal External Diameter (mm)	Weight Minimum kg/m
Quantum Sewer	PVCu	150	145	160	1.85
		225	226	250	4.20
		300	297	330	7.00
Quantum Highway	PVCu	150	148	160	1.25
		225	230	250	2.75
		300	302	330	4.65
Quantum Highway	HDPE	375	396	465	8.50
		450	496	580	13.30
		600	598	700	20.83

Pipe strength

	Pipe type	Pipe size	SN N/m ² @ 20°C
Minimum short-term ring stiffness	Marley solid wall	110mm	8000
	Marley solid wall	160mm	4000
Minimum short-term ring stiffness	Quantum Sewer	150-300mm	8000
	Quantum Highway	150-300mm	6000
Minimum two-year ring stiffness	Quantum Sewer	150-300mm	4000
	Quantum Highway	150-300mm	3000

Underground Design Pipe Laying

The following information is based on the recommendations in BS 5955: Part 6 'Installation of PVCu pipework for gravity drains and sewers' and BS EN 1610 'Construction and testing of drains

and sewers' and is intended as a general guide to good practice in the selection of bedding and backfill materials for Marley solid wall and Quantum underground drainage systems.



Excavation

Trenches should not be open for extended periods in advance of pipe laying and should be backfilled as soon as possible. It is essential that the sides of the trench are adequately supported during pipe laying.

Trench widths should be as narrow as is practicable but not less than the pipe diameter plus 300mm to allow adequate side fill to be placed. Deeper excavations should ideally incorporate a sub-trench in accordance with the diagram opposite.

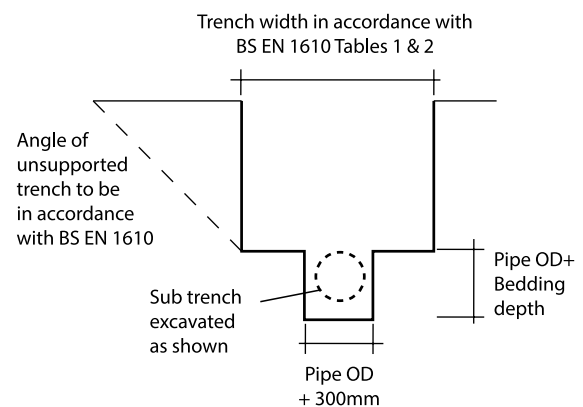

Granular material for bed & surround of PVCu drains and sewers

Suitable imported granular material for bedding and surrounding PVCu solid wall and Quantum pipes for private and adoptable sewer applications is detailed in the table opposite:

Grading complying with the requirements of BS EN 1610.

Nominal pipe size	Granular material size
100/110mm	10mm nominal single-size
	14 to 5mm course graded
150/160mm	10 or 14mm nominal single-size
	14 to 5mm course graded
150/225mm and over	10,14 or 20mm nominal single-size
	14 or 20 to 5mm course graded

Bedding & backfill

Where the as-dug material is suitable*, the bottom of the trench may be trimmed to form the pipe bed and the as-dug soil used as sidefill and backfill in accordance with BS EN 1610 bedding construction type B (see drawing below).

Where the as-dug material is unsuitable as bed and surround, installation should be carried out in accordance with BS EN 1610 bedding construction type 1, as shown below.

Trenches should be excavated to allow for the depth of bedding material. Before any pipework is installed the bedding material should be laid evenly along the bottom of the trench.

The sidefill material must be the same as the bedding material and extended to the crown of the pipe and be thoroughly compacted.

Where the backfill above the pipe contains stones larger than 40mm or where the pipework is deeper than 2m in poor ground, the granular material must extend at least 100mm above the pipe crown. Alternatively, backfill material can be graded to eliminate stones exceeding 40mm and this selected material used for the first 300mm above the pipe.

When the pipes are to be laid in rock, compacted sand or gravel, or in very soft or wet ground requiring mechanical means of trimming, the bedding should be a minimum of 100mm.

*Suitable material is defined as material in accordance with the recommendations of BS 5955: Part 6: Appendix A, having a maximum particle size not exceeding 20mm.

It is important to ensure that the ground is prepared correctly and that suitable bedding and backfill material is used, depending on the soil type and the loading required.

Shallow domestic drains

Pipes laid at depths less than 600mm and which are not under a road should, where necessary, be protected against damage by placing over them a layer of concrete, paving slabs or similar. A minimum 75mm cushioning layer of granular material must be laid between pipes and the slabs or concrete.

Where drains are laid in fields, additional protection may be required from heavy vehicles and equipment. It is recommended that the installation is carried out with a concrete slab spanning the trench as shown for drains under private roads (on opposite page below).

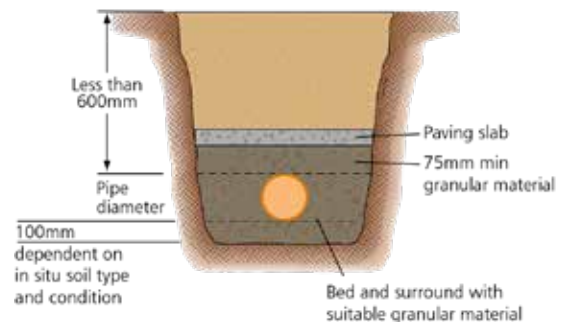

Drains under solid ground floors

Drains often have to be laid under buildings in order to connect sanitary pipework which has been positioned some distance from the outer walls. Where this occurs, deep hardcore within the foundation boundaries should be compacted first. The trench for the pipe should then be excavated and suitable material employed for the bedding and backfilling operation. If trenches are dug from original ground, pipes may be laid and surrounded as necessary before the top layer of hardcore is formed. Where a pipe passes through a wall or foundation of a building, a lintel or sleeve should be built -in to provide clearance around the pipe.

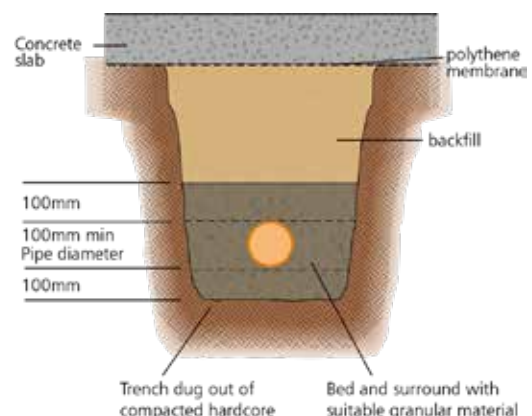

Concrete bed & surround

The flexible nature of PVCu pipes enables them to accommodate ground movement and other differential settlement that may occur under normal conditions. Therefore, the use of concrete bed and surround is not recommended and only under special circumstances, at very shallow cover depths or where it is necessary to safeguard foundations, should it be used. Where the use of concrete bed and surround is unavoidable, it is recommended that pipes are laid in 3 metre lengths and a compressible board is shaped to fit around each joint. Pipes should also be wrapped with polythene to prevent the ingress of cement slurry into ring seal joints.

Drains under private roads

If the depth of cover under a road or driveway is less than 0.9m, a concrete slab spanning the trench width is required.

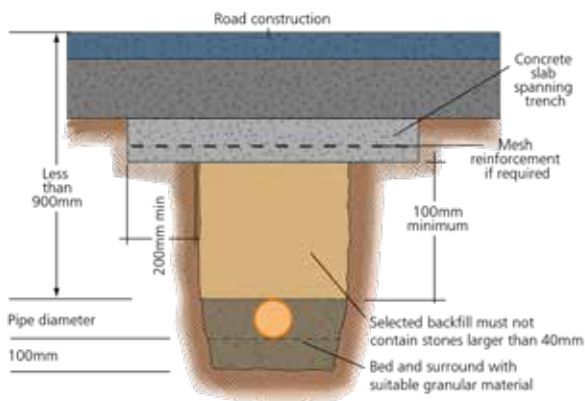

Adoptable sewers under roads

For adoptable sewer applications pipe bedding details should be in accordance with the Water Industry Specification. Selected as-dug material may be used for bedding and sidefill provided it meets the evaluation procedure and compaction fraction test values specified in WIS 4-08-01. The minimum cover under public roads should be 1.2m to the top of the pipe. The above information is for general guidance only and detailed proposals with regard to bedding and sidefill materials for sewers must be submitted to the relevant Adopting Authority for formal approval at the design stage of the project.

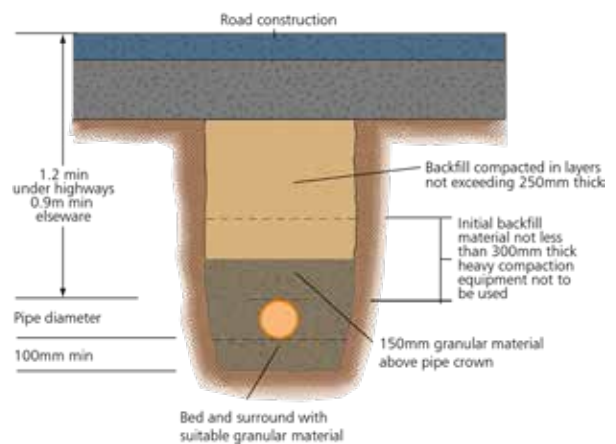

Shallow Inspection Chambers

Rodding points

A rodding point may be located at the head of a drain as an alternative to an inspection chamber or manhole. As rodding is only possible in one direction, which must be in the direction of flow, sufficient rodding points should be incorporated to provide access to all parts of the drain.

Since it is not possible to remove debris from a rodding point, a shallow access chamber, inspection chamber or manhole must be provided at a point downstream.

Rodding points should not be used on drains with invert depths of more than 2m and care must be taken during installation to ensure no load is transferred onto the branch upstand of pipe. The URP1 45° rodding point terminal may be used in situations accessible to light motor vehicles of up to 0.5 tonne wheel load provided it is bedded and surrounded in concrete.

Where rodding points are positioned in gardens it is also recommended that the area surrounding the terminal is paved or concreted to prevent the cover from becoming concealed by grass or soil.

Head of drain rodding point

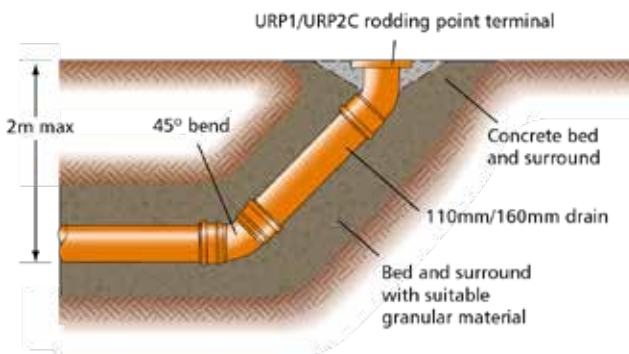

250mm inspection chambers

250mm inspection chambers may be used as an alternative to traditional manholes for invert depths up to 600mm. Intermediate depths can be accommodated by cutting the chamber riser using a hard tipped handsaw or similar.

The UCC7 is a one piece, level invert chamber with push-fit inlet and outlet sockets, making installation quick and easy.

Square or circular uPVC lids and frames are available for use with 250mm diameter inspection chambers and meet the loading requirements of BS EN 124 Class A15.

An alternative to the UCC7 is the level invert chamber base UAC44 with separate riser UAR1. Both square or circular lids and frames are suitable for use with this inspection chamber assembly.

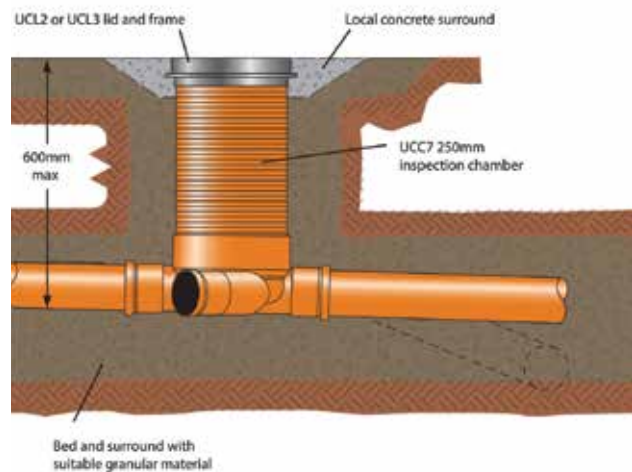

Underground **Shallow inspection chambers**

Inspection chambers

Where inspection chambers are used to make a 90° change of direction in the drain, 45° bends should be fitted to the inlet and outlet connections

to maintain a level invert through the chamber. It is also recommended that the peak flow in the drain is always discharged through the main channel and chambers are rotated accordingly on site to accommodate this.

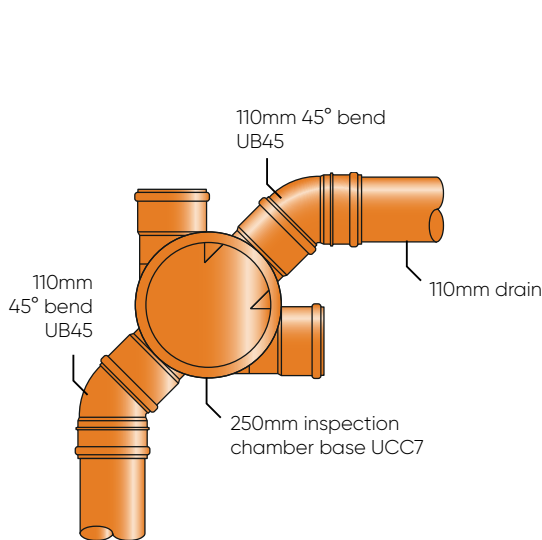

Typical 250mm inspection chamber 90° change of direction

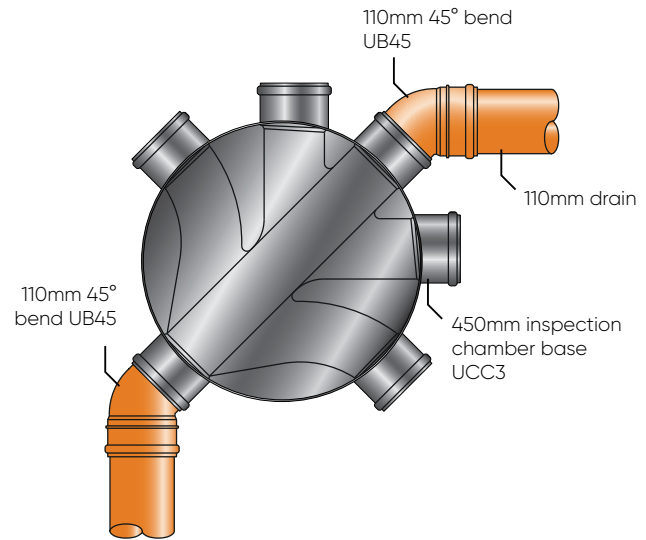

Typical 450mm inspection chamber 90° change of direction

Inspection Chamber product selector

Product	Inlet Size (mm)	Nominal Base Dia (mm)	Non SfA max invert level (m)	SfA type	SfA max invert level (m)	Kitemark approval
UAC02	110	250	0.6	X	X	X
UAC44	110	250	0.6	X	X	X
UCC7	110	250	0.6	X	X	X
UCC3	110	450	1	X	X	X
UCC250	110	250	2*	4	2	♥
UCC315	110	315	2*	4	2	♥
UCC450	110	450	4* †	3	3 †	♥
UCC5	110/160	450	4* †	3	3 †	♥

*Refer to local authority regulations for maximum allowable installation depth
 † 450mm inspection chambers require a 350mm reduced access when exceeding 1.0m in depth

Note: Kitemarked product performance:
 Max allowable groundwater depth above Invert (H) = 3m
 Max installation depth = 5m

250mm bottom outlet inspection chambers

The 250mm bottom outlet inspection chamber UAC02 provides a multiple collection point for branch drains from one or more dwellings and may also serve as a rodding and testing point for the main drain. The 110mm bottom outlet ensures that discharges from the side branches are quickly transmitted to the main drain which may be situated directly under the chamber or to one side at a lower level.

The bottom outlet chamber is ideal for situations where the main drain runs parallel to a building at a lower level as this allows the chamber to be positioned directly above the drain. Connection is then made using a back drop arrangement with a 45° branch and bend to the main drain.

Each chamber has four 110mm spigot inlets, three of which are open and the fourth can be opened for use if necessary. The UE43 plug can be used to blank off connections not required and the chamber riser UAR1 cut to accommodate invert depths of less than 600mm.

The UCL2 circular or UCL3 square lid and frame can be used to provide access to the chamber at ground level.

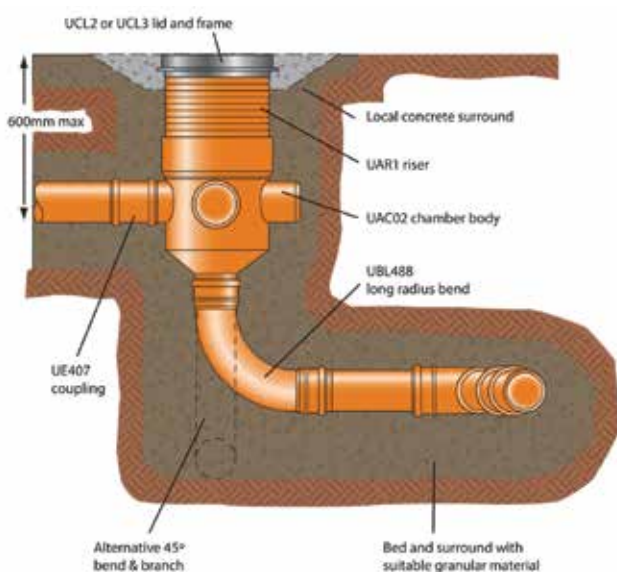

450mm inspection chambers

450mm inspection chambers may be used as an alternative to traditionally constructed manholes for invert depths of up to 1.2 meters. Intermediate depths can easily be accommodated by simply cutting a riser, between the ribbed sections, to the desired height using a fine tooth saw.

Chambers should be installed on a 100mm bed of suitable as-dug or granular material and care should be taken to ensure the bedding material is evenly compacted under the base so that the chamber is fully supported.

During the installation stage and prior to backfilling, it is recommended that chamber riser retaining clips UCC10 are fitted to maintain vertical alignment of the chamber during the backfilling operation. Sidefill material should extend to just below ground level and the cast iron cover and frame set in a concrete plinth.

Two versions of chamber base are available, the UCC3 has 110mm inlets and outlet and the UCC5 has 110/160mm inlets and 160mm outlet. Both have ring seal socket connections. When connecting the UCC3 or UCC5 chamber base to a riser, or jointing riser to riser, the ring seal is always located in the first groove, as detailed opposite. To ease jointing it is recommended that silicone lubricant is used.

The UCC5 160mm chamber base is fully compatible with 150mm Quantum pipe. This is achieved by removing the snap cap and seal from the chamber base and inserting Quantum pipe into the socket, with the seal located into the first corrugation of pipe.

450mm inspection chambers are designed to withstand water testing in accordance with BS EN 1610.

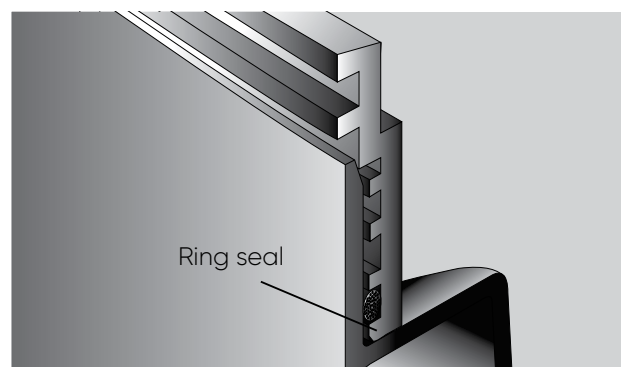

110mm (UCC3) / 160mm (UCC5)

Underground **Shallow Inspection Chambers**

450mm deep inspection chambers

For inspection chamber more than 1m depth (from cover to invert of pipe), safe egress cannot be achieved. To prevent unauthorised access, a recommended maximum clear opening size is 300mm x 300mm rectangular (350mm circular). Inspection and maintenance should be carried out by remotely operated equipment and the maximum depth is limited to 4m. Access is only permitted when there is no other alternative.

For full details please refer to the Building Regulations (England & Wales) Approved Document H – Drainage & Waste Disposal – April 2002 or Part 3 of the Building (Scotland) Regulations 2004 BSEN 752.

Please note that the standard UCC3 chamber base and UCR2 riser are not suitable for deep inspection applications.

Featuring increased ring stiffness over our standard inspection chamber riser, the UCR3 deep inspection riser must be used for all deep inspection applications.

Identifiable by tabs marked 'Deep Inspection' on the inside, each riser is 480mm high (effective height 440mm) and is supplied with a 450mm ring seal.

The UCR3 must be used in conjunction with the UCC5 or UCC450 inspection chambers for deep inspection.

The reduced access ring (UCLRR2) fits into the UCL35PP and UCL125 lid respectively and creates the required restricted opening for non-man entry.



Adoptable inspection chambers

Where adoptable inspection chamber systems are applicable:

Sewers for Adoption is applicable where a drain or sewer serves two or more properties and flows to the public sewerage network.

The Water & Sewerage company responsible for this network will require the contractor to have used adoptable inspection chambers to comply with sewers for adoption and Building Regulations.

Typical 250mm inspection chamber detail (Type 4)

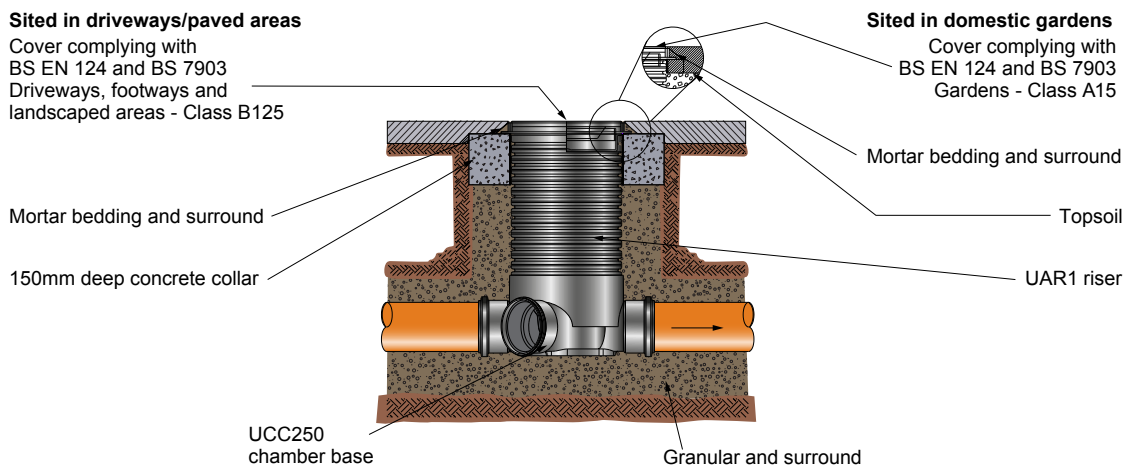

Typical 315mm inspection chamber detail (Type 4)

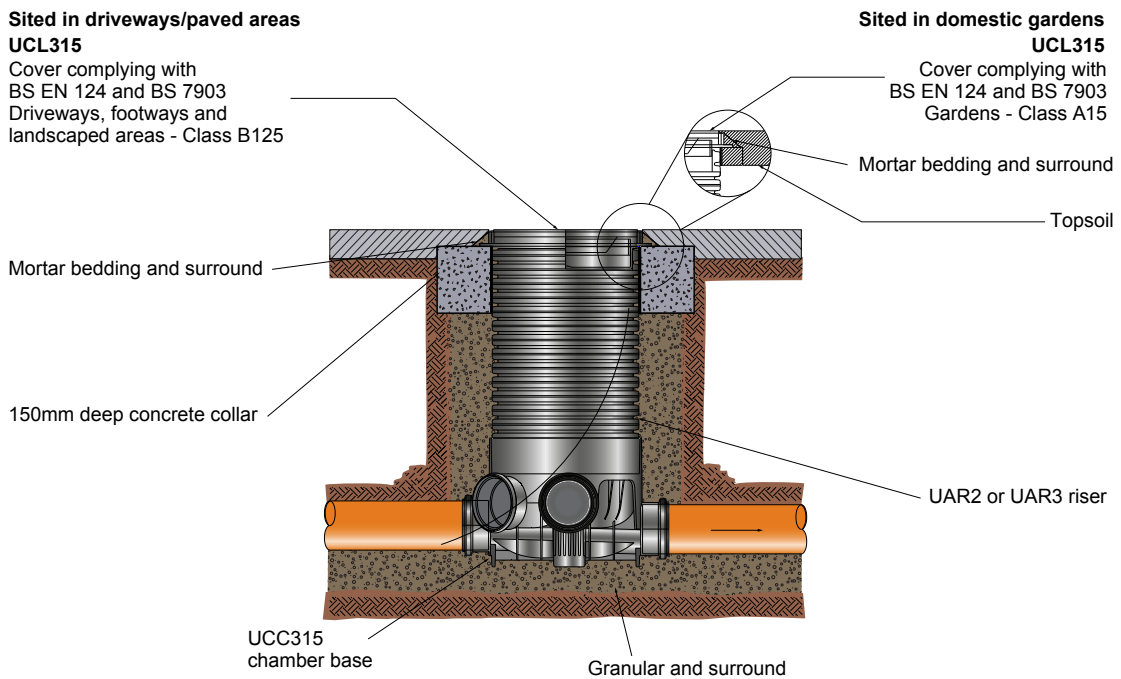

Underground Inspection Chambers

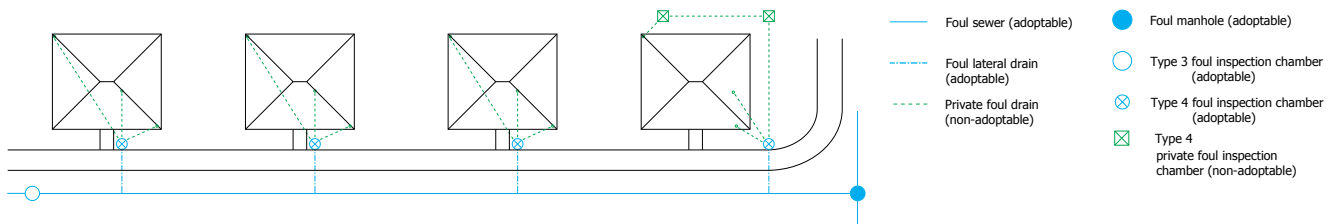

Typical 450mm inspection chamber detail (Type 3)

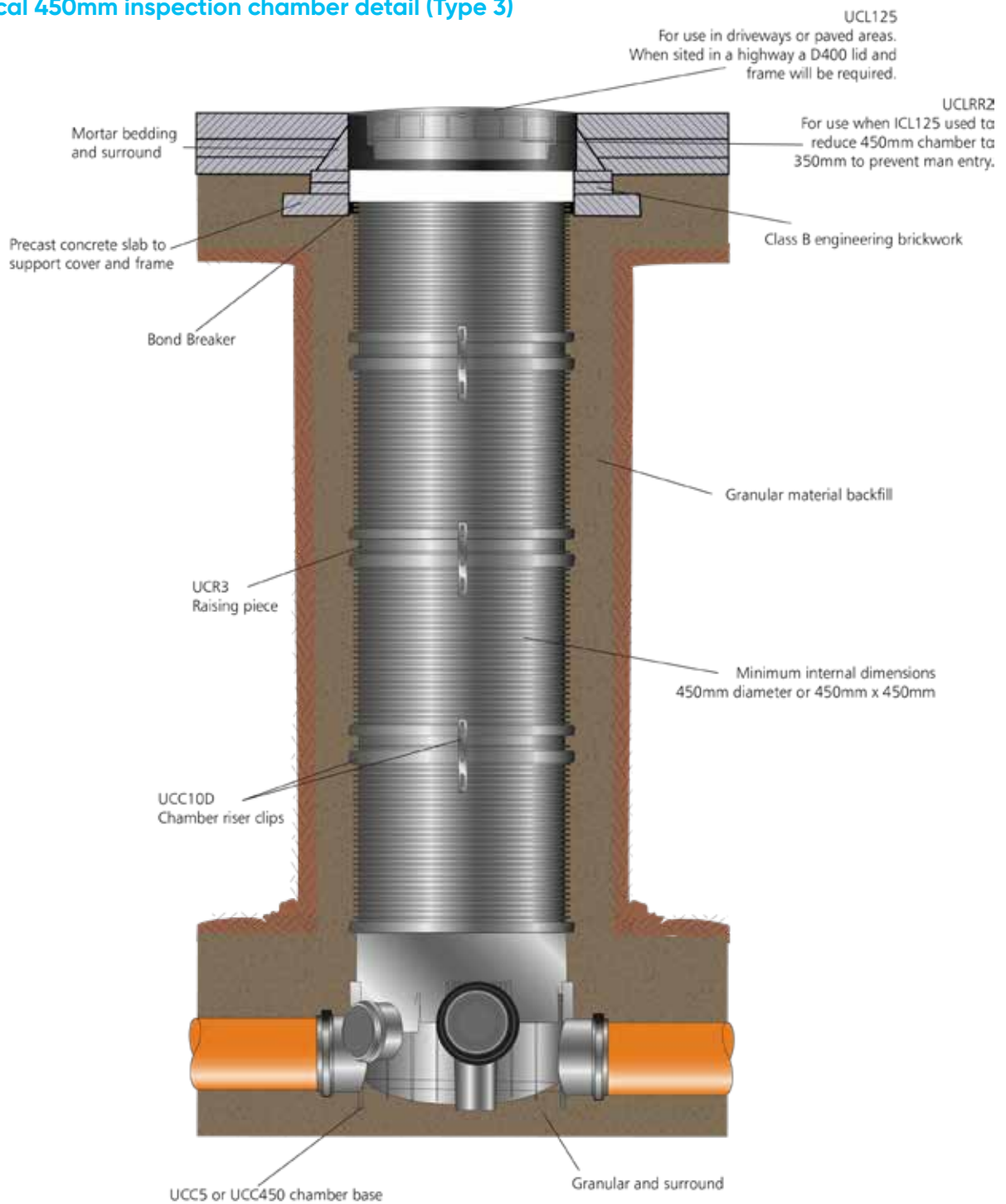

Underground Manholes

Open channel manholes

250mm inspection chambers provide an alternative to traditionally constructed manholes for invert depths of up to 600mm and 1200mm respectively. However, at greater invert depths there will be a need to construct manholes using brick or precast concrete sections.

For this reason a range of PVCu open channel pipes and fittings have been designed specifically for building into brick or concrete manholes. Each component is designed to provide a good key for sand and cement benching.

Where PVCu straight channel pipes and fittings are used, these should be bedded in cement mortar on a suitably prepared concrete base. Side branches

should connect to the main channel using slipper bends trimmed to the required angle of entry, which must be less than 90° and positioned to ensure a smooth discharge into the main drain.

Concrete infill and benching should rise vertically from the top edge of the channel to a height not less than the soffit of the outlet, and be sloped upwards to the wall of the manhole at a gradient of approximately 1 in 12. The surface should be floated to a smooth, hard finish with 1:2 cement mortar, laid monolithic with the benching and rounded off to a 25mm radius.

Where a 90° change of direction is required within an open channel manhole the 110mm long radius channel bend UCB48L may be used.

Manhole with open channel and slipper bend

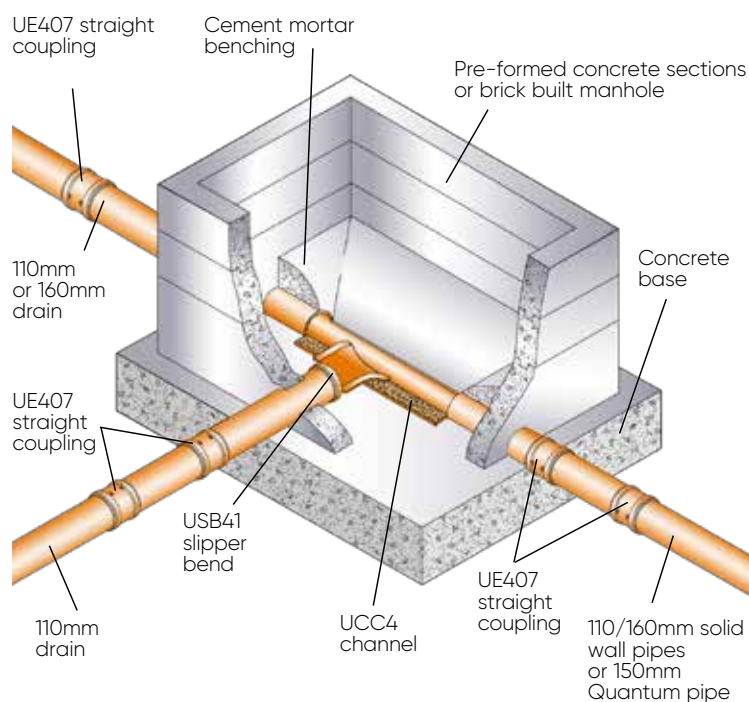

Adoptable manholes

For adoptable sewer applications manhole details should be used in accordance with the 'Sewers for Adoption Manual' and any additional requirements specified by the relevant Adopting Authority.

All changes in direction between incoming and outgoing sewers should be accommodated within the manhole chamber as no external bends are permitted.

Typical manhole chamber sizes for sewers between 150mm and 300mm diameter are as follows:

Depth to Pipe Soffit	Chamber Size
Less than 1m or 900 x 675mm	1050 diameter
1m to 1.35m or 1240 x 675mm	1350 diameter
1.35m to 6.0m	1200 diameter

External backdrops may be used where appropriate but are subject to approval. A typical construction detail is shown opposite.

Certain Adopting Authorities now allow the use of pre-formed chamber bases built into traditional manholes as shown opposite, providing that the directions of the sewers suit the angles of the inlets and outlet. However, prior approval of the Adopting Authority must be sought before utilising pre-formed chamber bases on adoptable sewer systems.

It is recommended that ring seal couplings are located as close as possible to entry and exit points of manholes to create 'rocker pipes' to accommodate any differential settlement that may occur following the backfilling operation.

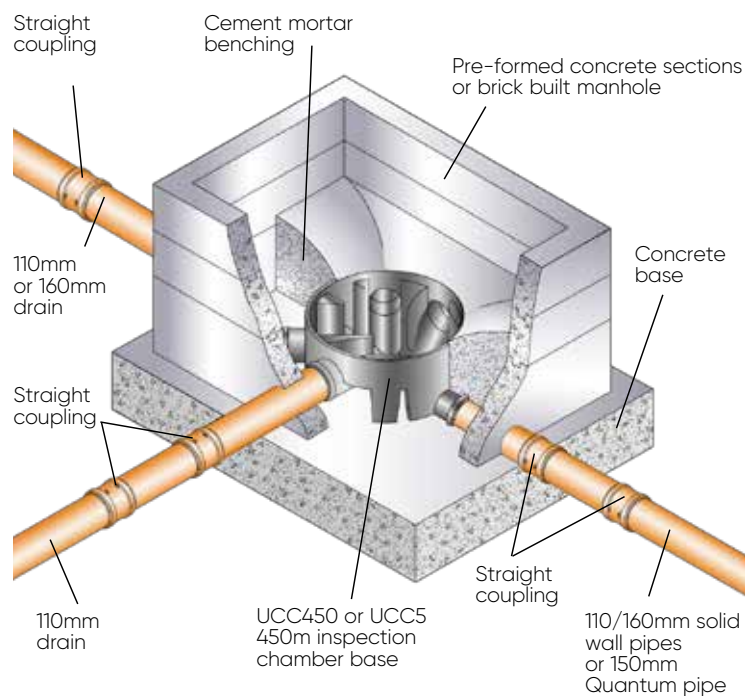

Underground Gully Combinations

A comprehensive range of gully components are available, allowing a wide variety of gully combinations to be assembled on site to accommodate different applications.

Square or rectangular gully hoppers

The square or rectangular gully hoppers UG47/UG48 and the gully inlet raising piece UW401 all have connections for small diameter pipework above the trap water level but below the gully grating.

Waste pipes can be connected using standard Marley universal boss adaptors, as illustrated.

The larger diameter upstands on the square or rectangular gully hoppers are designed to provide a solvent socket connection for 68mm circular rainwater pipes.

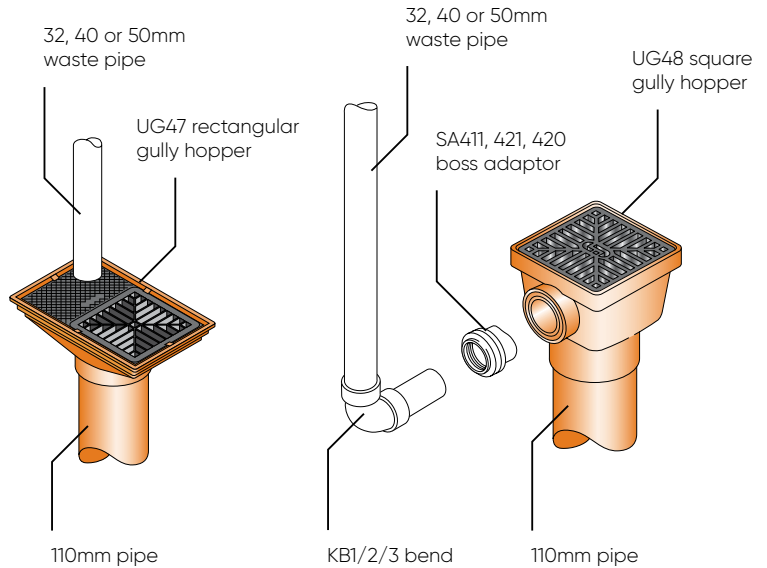

P trap gully

The double socket design of the UG42 P Trap Gully makes it ideal for use in restricted spaces and allows the trap to be orientated to suit the direction of the outlet pipe.

Both the square UG48 and rectangular UG47 hoppers can be connected to the gully using a short length of 110mm pipe cut to suit ground level.

The UG45 gully grating can also be used with the UW401 raising piece to receive waste pipe connections below ground level.

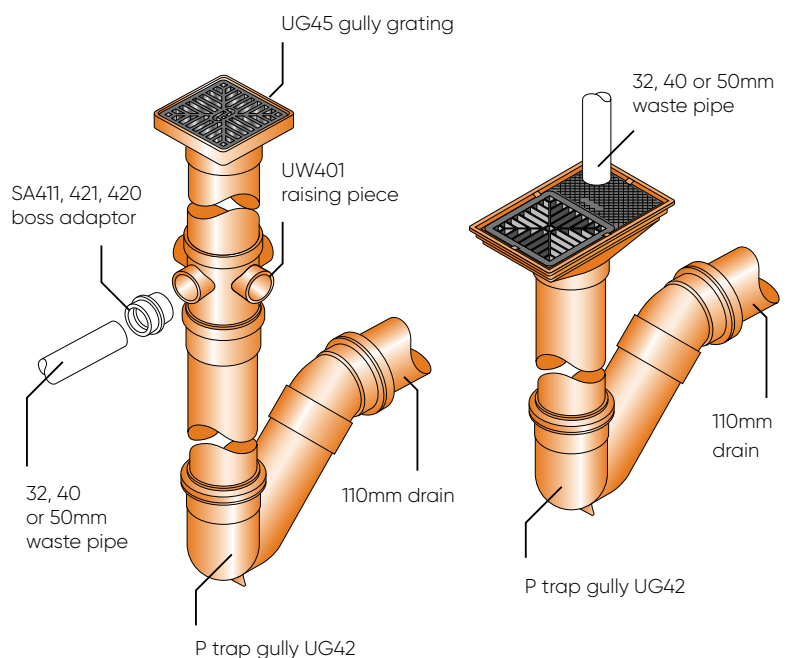

Bottle gully

The UG50 bottle gully is ideal for new or replacement installations and it provides the facility for direct 110mm connections and waste pipe connections via boss adaptors.

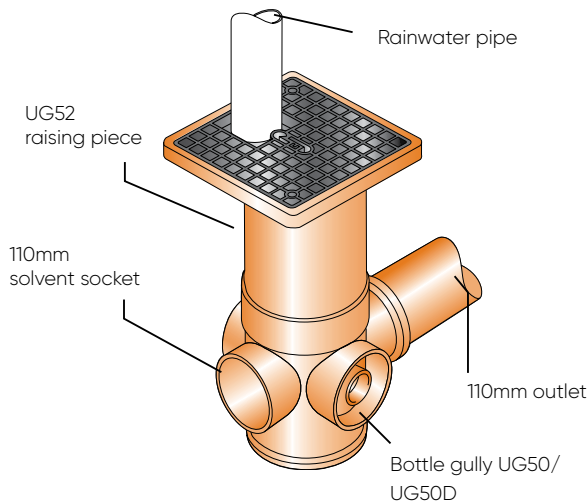

The fully rotating gully body allows the outlet to be orientated to suit the drain connection. A removable rubber plug provides access for cleaning.

The gully raising piece UG52 allows the gully to be installed at depths up to 520mm.

Installation procedure for bottle gully

1. Cut raising piece to required length by saw
2. Lubricate and push fit raising piece into top of gully body.
3. Gully frame spigot can then be solvent welded into top of raising piece. The gully grating may be secured to the frame if necessary with two 6 x 13mm self tapping pan head corrosion resistant screws (not supplied).

Road gullies

The Marley Gully Pot Liners UMA43 & UMA49 meet the requirements set out in DTp 'Specification For Highway Works' for use as permanent shuttering when forming an in situ concrete gully.

For DTp applications gully construction details to be in accordance with DTp 'Highway Construction Details' Drawing No. F13.

A standard UR61T seal and seal cap SNC6 are provided with each gully pot liner. These are to be fitted to a Quantum coupling or bend to enable a

direct push fit connection to be made to the gully pot spigot outlet.

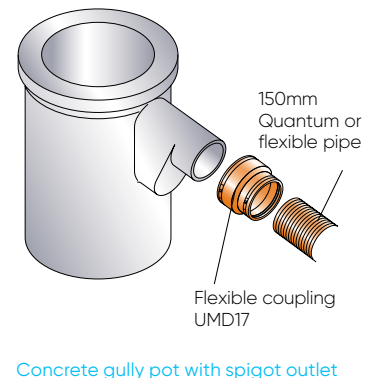
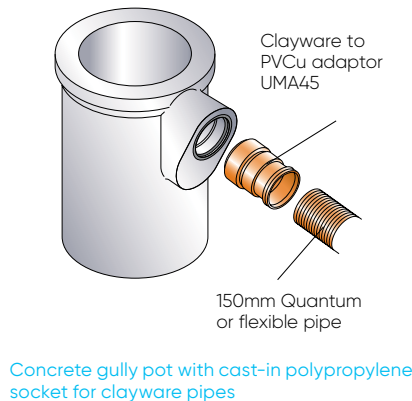
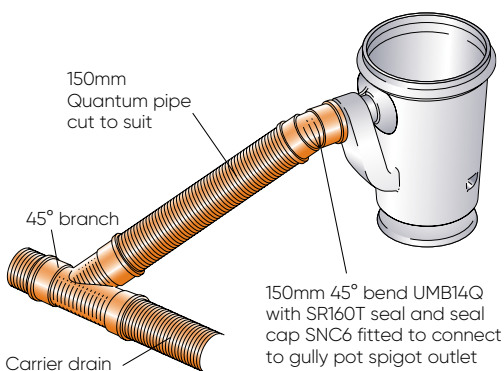
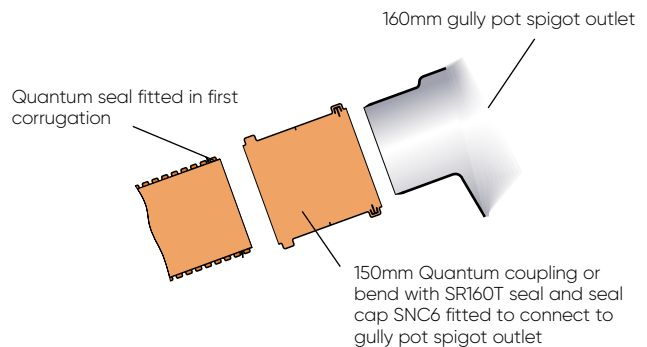

Underground Transition to Other Systems

Marley offer a range of adaptors which allow connections from soil or rainwater to drain, making the process quick and straightforward.

Stub waste connections

Isolated ground floor sanitary appliances are frequently supplied with their own 110mm drain in the form of an oversized and unventilated branch.

There are two methods of connecting waste pipework direct to drain. The SRM402 reducer may be used and solvent welded onto a plain spigot-upstand of pipe.

With the SE41 reducer a flexible connection is provided at floor level as this fitting push fits into a ring seal socket. Standard Marley boss adaptors are used with both types of reducer.

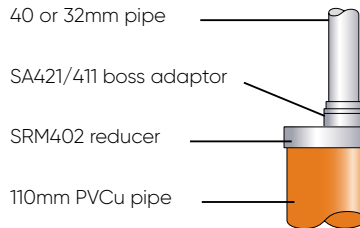

110mm PVCu to 40 or 32mm pipe

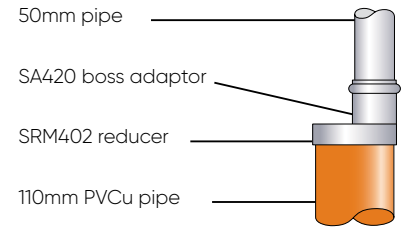

110mm PVCu to 50mm pipe

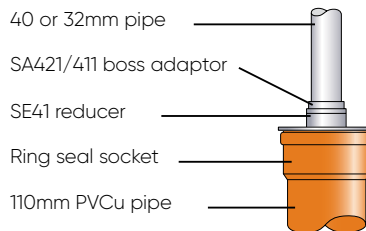

110mm PVCu to 40 or 32mm pipe

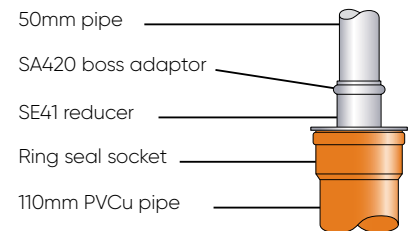

110mm PVCu to 50mm pipe

Rainwater pipe connections

External rainwater pipes usually connect direct to the drain or, depending on the design of the sewerage system, via a gully trap.

Where rainwater pipes connect directly to a drain and are of different sizes, a suitable reducer and adaptor fitting will be required.

The diameter of 110mm PVCu solid wall above and below ground drainage systems are the same and therefore direct connection may be achieved without an adaptor.

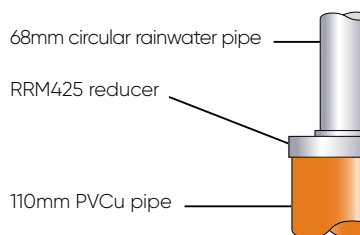

110mm PVCu to 68mm circular rainwater pipe

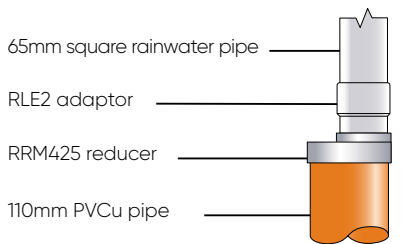

110mm PVCu to 65mm square rainwater pipe

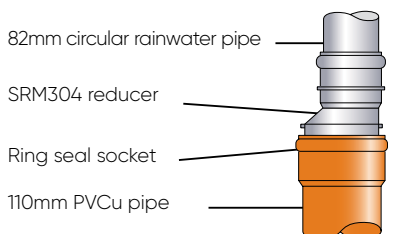

110mm PVCu to 82mm circular rainwater pipe

Connections to other materials

Marley also offer a range of adaptors allowing connections to be made to other materials, including clay. This allows for the replacement of existing sections of the pipe or simply to connect a new system to an existing one.

The UMA45 adaptor can be used to connect 160mm solid wall drainage pipes to BS EN 1401 to 150mm diameter nominal size clayware pipes as shown on page 45.

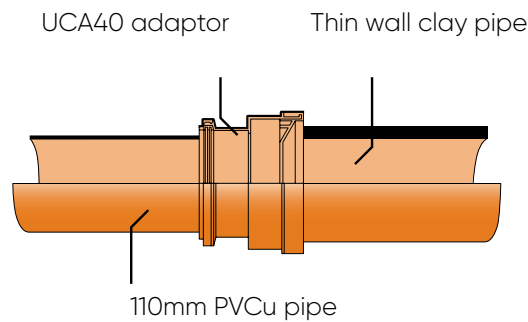

PVCu pipe socket to thin wall clayware socket

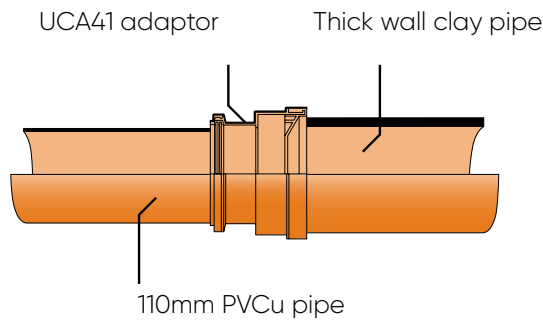

PVCu pipe socket to thick wall clayware socket

Flexible Couplings

Pipe	Flexible Coupling	Other Pipe Material
150mm Quantum (160mm outside diameter)	UMD17	150mm clayware
		150mm concrete
		150mm PVCu twin wall
		150mm outlet plastic
		Gully pot liners
		Maximum outside diameter of pipe – 200mm
225mm Quantum (250mm outside diameter)	UMD27	225mm clayware
		225mm concrete
		250mm ductile iron
		250mm PVCu pipes to BS 5481
		Maximum outside diameter of pipe – 290mm
		Minimum outside diameter of pipe – 265mm
300mm Quantum (330mm outside diameter)	UMD37	300mm clayware
		300mm concrete
		315mm PVCu pipes to BS 5481
		Maximum outside diameter of pipe – 385mm

Connection to 110mm solid wall drainage pipes

Connection between 150mm Quantum and 110mm solid wall pipe can be achieved by fitting a snap cap SNC6 and seal SR160T to the end of the socket. A connection can then be made to a reducer URM604 as shown right.

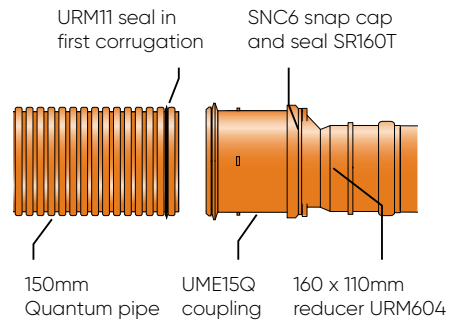

Connection to 160mm solid wall pipe

All 150mm Quantum sockets have been designed for use with Quantum pipes and 160mm solid wall pipes to BS EN 1401. To adapt a Quantum fitting to accept 160mm solid wall drainage pipe, a snap cap SNC6 and seal SP160T must be fitted to the end of the socket to enable a connection to be made, as shown right.

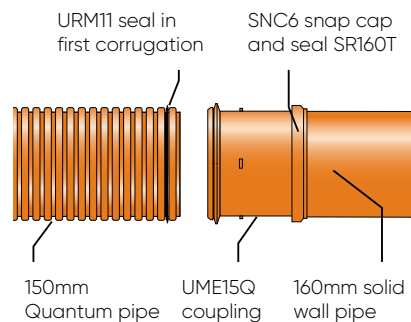

Quantum to thick wall clayware

The UMA45 adaptor may be used to connect 150mm Quantum pipe to Densleeve or Hepsleeve 188mm outside diameter clayware pipe.

The adaptor is designed to allow Quantum pipe to be jointed with clayware pipe using a standard clayware pipe coupler.

The UMA45 adaptor can be used to connect 160mm solid wall drainage pipes to BS EN 1401 to 150mm diameter nominal size clayware pipes as shown on page 45.

Installation procedure

1. Remove factory fitted 'T' seal from adaptor socket.
2. Fit Quantum seal on the pipe in the 10th corrugation from the end of the pipe ensuring the seal is correctly handed.
3. Lubricate the seal and inside the socket of the adaptor. Push the adaptor over the pipe, ensuring the pipe passes completely through the adaptor until the end of the pipe aligns with the end of the adaptor.
4. Lubricate the adaptor spigot and push into the clayware pipe coupler up to the central register.

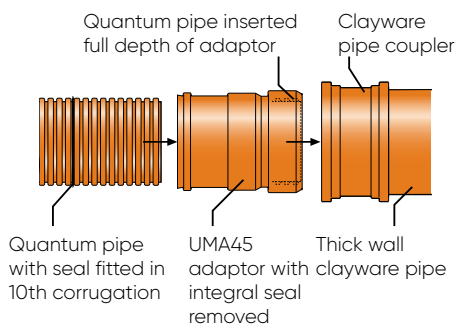

Quantum to thin wall clayware

The same adaptor can also be used to connect 150mm Quantum pipe to Hepsleeve or Supersleeve 178mm outside diameter clayware pipe. For this application the end spigot of the adaptor is first removed using a fine tooth saw. The remaining section of the adaptor is then suitable for connecting directly into a standard polypropylene clayware pipe coupler as shown right.

The installation sequence for this application is similar to that previously described but the seal is fitted on the Quantum pipe in the 6th corrugation from the end of the pipe to take into account the shortened length of the adaptor.

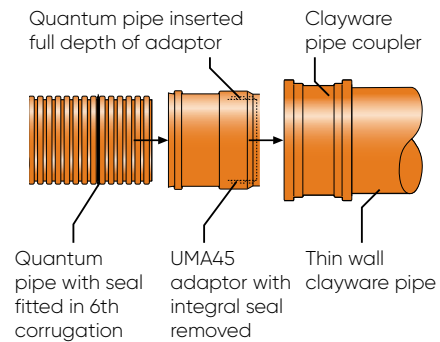

Solid wall PVCu pipe to clayware

The UMA45 adaptor can also be used as supplied to connect 160mm solid wall PVCu pipe to clayware drainage, as shown right.

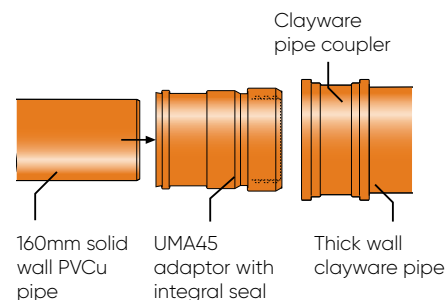

Underground Installation

Future connections

If a drainage system is likely to be extended in the future, branches at appropriate locations should be installed with the branch pipes blanked off with socket plugs. However, should it be required to install a new branch connection into an existing drain the following procedure should be adopted:

1. Materials required:- Branch fitting of appropriate size. Two short lengths of pipe (minimum length 300mm). Quantum pipe seals. Two slip couplings.
2. Fit the two short lengths of pipe into the branch fitting using the standard jointing procedure shown on page 44. Mark ends of pipe at half a coupling depth.
3. Use this assembly to mark the length of existing pipe to be removed and then cut out the section of pipe.
4. Ensure the ends of the existing pipe are free from dirt, swarf, etc.

Lubricate two slip couplings and slide fully over the ends of the existing pipe past the first corrugation.

5. Fit Quantum pipe seals to the first corrugation of each pipe end with the seals handed as illustrated to allow the couplings to slide back over the seals.
6. Lubricate all pipe seals and place branch assembly into position with branch pipe in desired plane.
7. Slide couplings back over joints using marks to ensure couplings are centralised on joints.

The above method of constructing a new connection to an existing drain meets the requirements of BS EN 1610: 2015 Clause 9-2.

A Quantum branch fitting can be installed into an existing concrete or clayware drain by following a similar procedure as described above but utilising appropriate flexible coupling in place of the slip couplings.

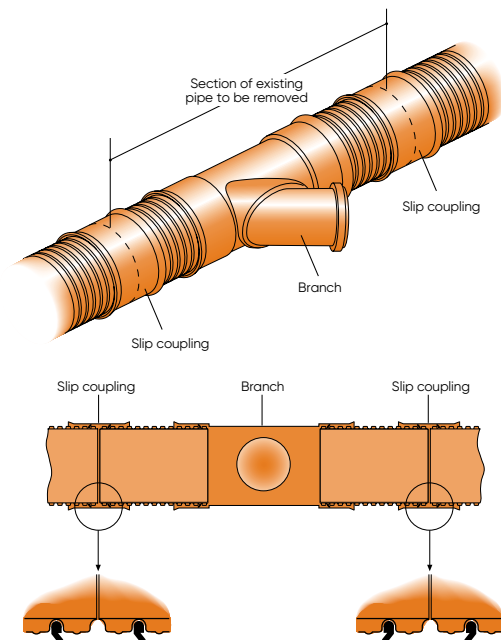

Pipe seals to be handed as shown to allow couplings to slide back over joint

Testing drainage systems

Air or water testing of systems should be carried out as required by the particular approving Authority. Reference should be made to the following documents for guidance:

Building Regulations Part H–Clause 2.26.

BS EN 1610: 2015 Sections 12 and 13.

It is recommended that air test method LA is adopted. However the standard water test can also be used.

Due to the non-absorbent nature of plastic materials the one hour conditioning period is not necessary prior to commencing a water test.

Rodding equipment

Marley underground drainage systems may be rodded using continuous flexible rods, sectional polypropylene rods or other similar flexible systems. Rodding heads should incorporate a guide roller, and rigid couplings between sectional rods should not exceed 100mm in length.

Pointed or boring type metal fittings are not recommended. Mechanical rodding techniques may be used with the exception of rotating toothed root cutters. These devices were primarily designed for use on traditional pipe materials where joint failure has occurred and allowed the ingress of roots. The incidence of PVCu ring seal joints failing in this way is extremely rare.

Water jetting uPVC drains and sewers

High pressure water jetting is now used extensively and is a recommended technique for the general cleaning, de-scaling and removal of blockages from both Marley solid wall pipes and Quantum drainage systems.

The Code of Practice for Sewer Jetting published by The Water Research Centre contains detailed guidance on the use of this type of equipment for drain and sewer maintenance. Adherence to the recommendations contained in this document is strongly advised when jetting all pipe materials.

The Code of Practice recommends for all house drainage systems and sewers where exact details of the condition, age and pipe material cannot be verified that a jetting pressure of 130 bar (1900 psi) is not exceeded.

Independent jetting trials for blockage clearance in PVCu pipes have conclusively demonstrated that the improved hydraulic performance and smoother internal bore allows most types of blockages to be removed using standard rear facing jet nozzles at jetting pressures well below the maximum recommended in the Code.

The Code of Practice recommends for all pipe materials that static jetting above 1900 psi is used only following confirmation that the pipeline being jetted is in good structural condition. Where up to date and accurate records of the condition of the sewer are unavailable a CCTV survey may be required prior to jetting above 1900 psi.

The Code of Practice recommends a maximum jetting pressure of 180 bar (2600 psi) for uPVC pipes, when using a standard jet head.

Where the distance from the access point to the blockage exceeds the travel capability of the standard jet head running at 180 bar (2600 psi) the use of a low impact jet head will allow higher pressures (thus great running distance) to be achieved without increased risk of pipe damage.

The jet head manufacturer's recommendations for maximum operating pressures should be observed when using these types of jet head.

Underground Safety

Safety

The relevant regulations as outlined in the Health and Safety at Work Act 1974 should be followed. Also follow the recommendations contained in the booklet 'Safe Working in Sewers and Sewerage Works' published by the National Joint Health and Safety Committee for Water Services.

Transportation and handling

PVCu pipes and fittings are strong and lightweight and therefore very easily handled, however, reasonable care should be exercised. During transportation loose pipes should preferably be loaded and unloaded by hand but if mechanical equipment is utilised, web or rope slings are recommended.

Larger quantities of pipes are delivered in secure bundles within timber frames and wherever possible the pipes should remain within this packaging until required for installation. It is recommended that pipe bundles are unloaded by forklift or by using web or rope slings.

Fittings are generally packed in cardboard boxes, plastic bags or in shrink-wrapped form.

Storage of loose pipes on site

Pipe bundles may be stacked up to three high on firm level ground ensuring that the frames are placed 'wood to wood' to avoid damaging the pipes. Pipes should not be removed from any position within stacked bundles. Before removing pipes the bundles should be placed at ground level and provision made to retain the frames in an upright position as pipes are removed. Although Marley Quantum pipes have a corrugated external profile their unique design allows them to be easily slid out without the corrugations interlocking.

Pipes which have been delivered loose or have been removed from pre-packed bundles should

be stored on a reasonably flat, level surface on timber battens not less than 75mm wide spaced at a maximum of 1m centres. Side support should also be provided at intervals not exceeding 1.5m.

Pipes of different sizes should preferably be stacked separately but where this is not possible larger diameter pipes should be placed at the bottom. Spigot and socket pipes should be stacked with sockets at alternate ends protruding to ensure pipes are evenly supported over their length.

Pipes stored in the open for long periods or exposed to strong sunlight should be covered with an opaque sheet (not black). Fittings supplied in cardboard boxes or polythene bags should be stored in a cool place out of direct sunlight and away from any heat source.

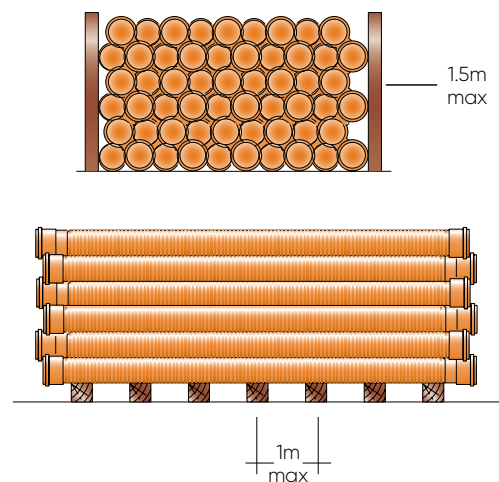

Solid wall pipes

Size	Pipes per Bundle
110mm	100
160mm	46

Quantum sewer & highway drainage pipes

Size	Pipes per Bundle
150mm	46
225mm	16
300mm	9

Aliaxis, through our different brands, offers a wide range of products to complement the Marley portfolio, from UPVC pressure fittings to expansion couplings and more.

For more details, we have the following brochures available:



Nicoll

ASTORE

FIP

REDI



Contact us: middleeast@alixis.com

Aliaxis Middle East | T: +971 (0) 4 3629423 | F: +971 (0) 4 4587599
P.O Box 488100 Dubai, UAE | Indigo Tower Office 702 Cluster D, JLT

alixis-me.com

