



A Division of Dura Automotive Systems

1120 North Main Street • Elkhart, IN 46514

PHONE: 574•264•2131 FAX: 574•262•2550

INTERNET: <http://www.atwoodmobile.com>

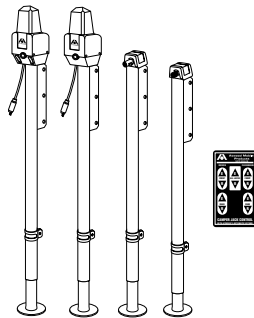

LITERATURE NUMBER MPD 87903

ACME & BALL SCREW TRUCK CAMPER JACKS

INCLUDES REMOTE CONTROL FOR ELECTRIC BALL SCREW JACKS (4 JACK SETS)

ENGLISH, FRANCAIS (et Canada)

•Installation •Operation •Maintenance

REFERENCE NUMBERS REFER TO ILLUSTRATIONS ON BACK PAGE

Effective 5/22/07

SAFETY ALERT SYMBOLS

Safety Symbols alerting you to potential personal safety hazards. Obey all safety messages following these symbols.

WARNING
avoid possible injury or death

CAUTION
avoid possible injury and/or property damage

FOR YOUR SAFETY

READ ALL INSTRUCTIONS BEFORE OPERATING JACKS

Installer: Provide these instructions to the consumer.

Consumer: Keep documents for future reference.

Atwood Acme and Ball Screw Truck Camper Jacks are designed to be used in sets of four with one at each corner of the truck camper. The maximum static load and lifting capacity is:

SCREW	SYSTEM	PER JACK
Acme	2,250 lbs.	1,250 lbs.
Ball	3,900 lbs.	2,200 lbs.
Heavy Duty Ball	5,000 lbs.	2,800 lbs.

Atwood makes two types of Electric Ball Screw Truck Camper Jacks (EBSTCJ); one with remote capability and one without. **They are not interchangeable. Our remote control is designed for use only with Atwood Electric Ball Screw Truck Camper Jacks (EBSTCJ) equipped for remote control capability.** The camper must be wired specifically for the remote.

See Chart below for the recommended maximum loading for a four jack system based on the bracket kit used.

Bracket Kit	Truck Camper Wet Weight		
	2250 lbs. – or less	2250 lbs. – 3900 lbs.	3900 lbs. – 5000 lbs.
Narrow Front Narrow Rear with lower clamp	X		
Wide Front Wide Rear with no lower clamp	X		
Wide Front Narrow Rear with lower clamp	X	X	
Wide Front, Wide Rear with lower clamp	X	X	X

WARNING PERSONAL INJURY & PRODUCT DAMAGE

- Never store camper on the jacks.
- Never exceed rated jack and/or camper capacity. Camper can collapse and tip over.
- Do not operate jacks if the camper exceeds gross vehicle weight.
- Only operate jacks when camper is unoccupied and contents are secured and properly distributed.
- Maintain proper load distribution and a safe distance when raising or lowering camper.
- Park the camper on a firm, level site.
- Never walk under the camper when it is extended on the jacks.
- Do not lift the truck with the jacks.

WARNING PERSONAL INJURY & PRODUCT DAMAGE

- Unplug the remote control when not in use.
- Store remote in a secure place, away from access by children.

INSTALLATION

NOTE: Camper manufacturer must insure camper side walls are sufficiently reinforced at corners for mounting jacks.

1. Bolt together flat and formed pieces of each corner bracket using 3/8" x 1" grade 5 bolts, flat washers and bolt retainers (supplied) as shown in FIG 1 or 4. Bolts must extend from the formed piece through the flat piece.
2. Position brackets on corners so that jack will be perpendicular to ground when camper is level. (See FIG 3) On rear corners with a lower support bracket, place it at least 12" below main corner bracket. See FIG 3-A.
3. On all corner brackets and lower support brackets, drive 1/4" diameter lag screws (not supplied) into camper's corner through center of each slotted hole into camper framework. Minimum length of lag screw must be 1-1/4". See FIG 2-A for wide brackets and FIG 5-A for narrow brackets.

NOTE: Holes are slotted to allow brackets to tighten up to the camper's corners as installation is made. Positioning lag screws in center of slots permits bracket to shift without affecting the integrity of the corner.

4. On wide brackets, use steel angles (not supplied) on inside of camper's corners to provide sufficient support. See FIG 2-B. Use four (4) 3/8" bolts, lock washers and nuts (not supplied) to bolt through each wide corner bracket, side wall and steel angle. Torque bolts to 15-20 ft. lbs.
5. Mount jacks to 3/8" x 1" long grade 5 hex bolts protruding from corner brackets (installed in STEP 1 above). Use flat washers and locknuts (SUPPLIED) to retain jack. Torque to 15-20 ft. lbs. See FIG 2-C for wide and 5-B for narrow (bolt retainer not shown for clarity).

NOTE: Jack must be located so handle clears all obstructions when cranked.

NOTE: For trucks with dual rear wheels, use Swing-Out Brackets to allow the front jacks to swing out to a wider position to clear dual wheel fenders. Follow Swing-Out Bracket instructions MPD 87904 for proper installation and safe use.

6. For rear jacks with lower clamps, carefully spread clamps far enough to slip over rear jack tube. Push onto jack and attach to lower support brackets with 3/8" x 1" long, grade 5 hex bolts, flat washers, and locknuts provided. Torque bolts to 15-20 foot lbs.

Electric Ball Screw Jack WITHOUT REMOTE CONTROL - FIG 6 & 7

7. Locate electrical receptacles on front and rear of camper as shown by the rear view in FIG 9 with 4-wire connectors on driver side and 2-wire connectors on passenger side of camper. Receptacles must be mounted within 5" from edge of camper, see FIG 9-A.
8. Make electrical connections as shown in FIG 10 with front and back jacks on separate 30 amps circuits with fuses located within 18" of battery. Use 10 gauge stranded copper wire. Wiring must met RVIA codes.

- A - Driver side
- B - Passenger side
- C - Red w/White stripe
- D - 30 amp fuse
- E - Black w/White stripe
- F - Black
- G - Red

Electric Ball Screw Jack WITH REMOTE CONTROL - FIG 7

7. Mount two wire connectors on front and rear of camper within 5" from edge of camper.

**⚠ CAUTION
PRODUCT DAMAGE**

- Disconnect power to the power relay module prior to HiPot testing of the camper or the microprocessor will be damaged.

TO INSTALL THE WIRELESS REMOTE CONTROL, REFER TO INSTRUCTION MPD 87920.

OPERATION

**⚠ WARNING
CAMPER CAN TIP OVER**

- Soft or spongy areas may cause jacks to sink, causing camper to tip over. Park the camper on a firm, level site.
- Insure area below and around jack is clear of obstructions.
- Do not place blocks under the jack for additional ground clearance.
- Always keep the front of camper higher than or equal to the rear of the camper. Never allow either side or end of camper to be more than 4" out of level. See FIG 12 and 13.
- Do not use the jacks to raise the truck, such as to change a tire. The jacks are designed only for lifting and lowering the camper onto the truck and for stabilization of camper.

**⚠ CAUTION
PRODUCT DAMAGE**

- Do not over extend or over retract jacks. Each jack has built in stops. Excessive force applied against the stops will cause damage.
- Do not use pneumatic tools to operate any jack. They can over-extend or over-retract the jack.
- Do not use the jacks to level the truck and camper. This will overload the jacks.

ACME JACK — FIG 14

**⚠ CAUTION
PERSONAL INJURY/PRODUCT DAMAGE**

- Do not use pneumatic tool to run drill adapter.
- Battery operated drills, 9.6V to 18V, are powerful. Hold drill with both hands to protect your wrist. Keep loose clothing and body parts away from drill as the reaction torque from the drill may cause it to kick back.
- Refer to your drill manufacturer's operation manual.

To extend or retract jack, push handle onto drive shaft and rotate slightly until drive pin is engaged in handle slot. Rotate handle clockwise to raise camper or counterclockwise to lower camper. Follow instructions in **To LIFT OR LOWER TRUCK CAMPER** section. To remove handle, reverse above procedure. A drill adapter is provided, for even faster set-up or tear-down (FIG 15 and caution above). Follow instructions in **To LIFT OR LOWER TRUCK CAMPER** section.

MANUAL BALL SCREW JACK — FIG 16

To extend or retract jack, push handle onto alignment tube and depress release bar with plastic push collar (FIG 17). Hold plastic push collar in place with one hand and rotate handle slightly with the other hand until black pin engages at either end of handle "T" slot. Rotate handle clockwise to raise camper or counter clockwise to lower camper. Follow instructions in **To LIFT OR LOWER TRUCK CAMPER** section.

**⚠ WARNING
PERSONAL INJURY & PRODUCT DAMAGE**

- Always maintain positive pressure on handle until the release bar is completely back into place, engaging the drive pin.
- Do not use quick-to-ground feature with handle in place. Handle will spin and can cause property and bodily injury.

To remove handle, hold plastic push collar in place with one hand and back handle off with the other hand until the pin is engaged in the middle of handle "T" slot. Release bar should audibly and visually spring back into position. To do so the handle must be in the vertical position (FIG 17).

NOTE: If jack is supporting camper, it may be necessary to rotate handle clockwise slightly to relieve load on Release Bar before Release Bar can be disengaged.

Manual Ball Screw Jacks have a quick-to-ground feature. To drop jack foot quickly to ground: push in both sides of Release Bar, then step down on jack foot to drop it to the ground.

NOTE: Quick-to-ground feature may not work freely until jack has been used several times because of close tolerances built into jack.

ELECTRIC JACKS

**⚠ CAUTION
PRODUCT DAMAGE**

- Do not over-extend or over-retract jacks. The electric jack has an internal slip clutch to help prevent damage; when clicking sound is heard, release switch. Continuing to hold the switch will wear out the slip clutch or cause damage to the motor.
- If the motor will not extend/retract the jack and the motor is making a ratcheting sound (clutch slipping), do not use the manual override. Immediately contact an Atwood Service Center and have jack replaced. Do not use the jack until replaced.
- If grinding operation should occur or any indications of improper or inadequate performance, have a trained service professional inspect the jack set.



Electric Ball Screw Jack WITHOUT REMOTE CONTROL — FIG 6 & 7



Press switches on driver side jacks to raise and lower camper. Press top of switch to retract jack (RET) or bottom of switch to extend jack (EXT). You may need to first turn on power to jacks using switch inside your camper. Follow instructions in **To LIFT OR LOWER TRUCK CAMPER** section.

Manual Override Operation: To manually extend or retract jack, place manual override handle (FIG 8-A) into alignment tube (FIG 8-B) and engage drive pin. Rotate handle counter-clockwise to raise or clockwise to lower camper.

Electric Ball Screw Jack WITH REMOTE CONTROL — FIG 7

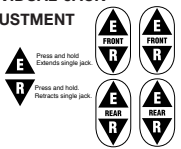
Remove the hand held remote control from its secure compartment. Push activation switch to energize for wireless remote. Operator and all spectators must stand a safe distance from the camper.

To LIFT Truck Camper WITH REMOTE CONTROL	
<p>EXTEND FRONT JACKS FIRST</p> 	<p>Disconnect the front and rear tiedowns. Extend front jacks so camper is 4" higher in front than in the rear. (see FIG 12).</p>
<p>EXTEND ALL JACKS</p> 	<p>Once the camper front is higher than the rear, press and hold the ALL JACKS BUTTON, extend (▲). Release when the camper is at the desired height.</p>
<p>INDIVIDUAL JACK ADJUSTMENT</p> 	<p>Use the individual jack buttons to adjust an individual jack. Press and hold the extend or release buttons for the individual jacks as needed to keep the front of the camper 4" higher than the rear, to prevent tipping over the camper. Keep all corners within 4" of level with each other.</p>

To LOWER truck camper WITH REMOTE	
<p>RETRACT REAR JACKS FIRST</p> 	<p>Retract rear jacks so camper is 4" lower in rear than in the front. (see FIG 13).</p>
<p>RETRACT ALL JACKS</p> 	<p>Once the camper has the rear lower than the front, press and hold the ALL JACKS BUTTON, retract (▼). Release when the camper is at the desired height.</p>
<p>INDIVIDUAL JACK ADJUSTMENT</p> 	<p>Use the individual jacks buttons to adjust an individual jack. Keep all corners within 4" of level with each other.</p>

NOTE: **FOR CONSUMER PROTECTION:** The Remote Control System has a built in low voltage shut off. If voltage drops below an unacceptable voltage, the power controls will chatter (click) and system will not perform as intended. Noise indicates the battery must be charged.

Manual Override Operation: To manually extend or retract jack, unplug jack from camper to disable the jack motor's dynamic brake. Place manual override handle (FIG 7-A) into alignment tube (FIG 8-B) and engage drive pin. Rotate handle counter-clockwise to raise or clockwise to lower camper. Plug the jack back into camper to activate the jack motor's dynamic brake.

NOTE: No damage will occur to jack if jack is not unplugged, it will just be harder to manually crank.

To LIFT Truck Camper

Disconnect the front and rear tiedowns, crawl-through boot, stabilizers and hitch extension bar, as applicable.

STEP 1 - Elevate FRONT jacks a maximum of 4" (FIG 12).

STEP 2 - Elevate rear jacks only until camper is level (max. of 4"). (FIG 13)
Repeat step 1 and step 2 until desired clearance is achieved.

See FIG 12 and 13. Raise camper until bottom of camper clears truck bed. Disconnect electrical connections between camper and truck. Slowly drive truck from underneath camper. Lower camper to lowest possible position without any part of camper touching the ground.

To LOWER Truck Camper

STEP 1-Retract REAR jacks a maximum of 4", insure camper is not more than 4" out of level. Front jacks may need to be lowered first.

STEP 2-Retract front jacks only until camper is level (maximum of 4").
Repeat as needed.

Connect the front and rear tiedowns. Check that all are secure.

REMOVING CAMPER FROM TRUCK

Following instructions in **To LIFT OR LOWER TRUCK CAMPER** section and FIG 12 & 13, raise camper high enough to clear the truck bed.

Disconnect electrical connection between camper and truck (refer to your camper operation instructions or contact the camper manufacturer for more information). Slowly drive truck from underneath camper. Lower camper to lowest possible position without any part of the camper touching the ground.

 <p>CAUTION</p> <p>PERSONAL INJURY & PRODUCT DAMAGE</p>
<ul style="list-style-type: none"> Do not enter camper after it is removed from truck until it is lowered to its lowest position. This will minimize sway which could cause structural damage to the camper or jacks.

LOADING CAMPER ON TRUCK

Follow instructions in **To LIFT OR LOWER TRUCK CAMPER** section and FIG 12 & 13, raise camper high enough to clear truck bed. Carefully back truck under camper making sure not to damage any portion of the camper or jacks. Camper should be centered in truck bed with front of camper as far forward in truck bed as possible. Attach electrical connections between truck and camper, (refer to your camper operating instructions or contact the camper manufacturer for further information). Lower camper into truck bed, then fully retract all jacks.

To use the jacks as stabilizers, extend the jacks to the ground. Extend the jacks only 2-3" more to take the bounce out when people move around inside the camper.

MAINTENANCE

- Internal parts of jack are permanently lubricated at the factory and do not require any further lubrication.
- At least once each camping season fully extend jacks and clean dirt and grime from outside of inner tube. Coat entire outside of inner tube with silicone spray lubricant. This will protect the finish of the inner tube and provide lubrication between the jack's tubes. Clean dirt and grime from outer housing. Spray the alignment tube inside and out with silicone (FIG 8-B & 17-A).

NOTE: If it is not possible to get jack to operate freely, replace jack.

- Apply a good automotive polish or wax to the outer tube of the jacks to maintain the appearance.
- Should problems or questions arise, contact your dealer, the camper manufacturer, or the Atwood Service Department (574) 262-2655.

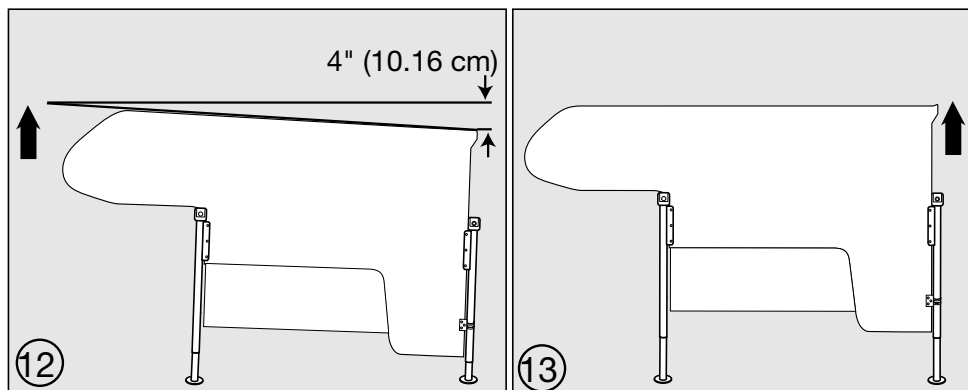

ATWOOD LIMITED WARRANTY HARDWARE SYSTEMS & COMPONENTS

Atwood Mobile Products warrants to the original owner the product will be free of defects in material and workmanship for a period of two years from the date of purchase. Atwood's liability hereunder is limited to the replacement of product, repair of product or replacement of product with a reconditioned product, at the discretion of the manufacturer. The warranty is void if the product has been damaged by accident, unreasonable use, neglect, tampering or other causes not arising from defects in material workmanship. The warranty extends to the original owner of the product only, and is subject to the following conditions:

1. For two (2) year commencing with the date of purchase, Atwood will replace or repair any Hardware System & Components that are found to be defective by Atwood in material or workmanship.
2. In the event of a warranty claim, the Original Purchaser must contact the Atwood Consumer Service Department, 1120 North Main, Elkhart, IN 46514, Telephone: 574-262-2655 Fax: 574-522-4188. Warranty claim service must be performed as approved by the Atwood Consumer Service Department. Warranty replacement hardware systems and components or parts will be furnished freight prepaid. Labor cost to repair or replace will be limited to the amount of the original purchase price of the systems and components. The replaced warranty products or parts become the property of Atwood Mobile Products and must be returned to the Atwood Consumer Service Department freight prepaid, unless prior arrangements have been agreed to.
3. This limited warranty is valid only when the product is applied, installed, maintained and operated in accordance with this Atwood Installation, Maintenance and Operating Manual. Any deviation from these recommended specifications must be approved in writing by Atwood.
4. Any implied warranties are limited to the duration of this limited warranty as stated above. Atwood does not assume responsibility for consequential damage or loss, including loss of use of vehicle, loss of time, inconvenience, expense for gasoline, telephone, travel, lodging, loss or damage to personal properties, or loss of revenues. Some states do not allow limitations on how long an implied warranty lasts or limitations on consequential damages, so the above limitations may not apply to you. This limited warranty gives you specific legal rights which may vary from state to state.