

OWNER'S
TRUCK CAMPER
MANUAL

Welcome to Coachmen's growing family of happy RV owners. Hours of relaxation, adventure and enjoyment await you in your new Coachmen unit. Thousands of Coachmen RV owners have been enjoying their units for many years.

This Owner's Manual has been prepared to help you and your family enjoy your new Coachmen RV to its fullest by providing basic instructions for the operation and maintenance of its appliances, accessories and RV systems. Please read it carefully and follow the instructions. Also read and follow the instructions contained in the chassis, appliance and accessory manufacturers' instruction booklets provided as part of the "Coachmen Information Packet."

If you have any questions regarding operation, maintenance or service, please contact your Coachmen dealer so he can assist you. Your satisfaction is of the utmost importance to your dealer and to Coachmen.

Operation and maintenance instructions regarding appliances in this manual were obtained from the manufacturer's booklets and are used with the permission of those various manufacturers. Coachmen Industries reserves the right to present edited portions of these materials.

Coachmen Industries, Inc. works year round to improve its product. As a result, all specifications, equipment and prices quoted are subject to change without notice or obligation to the consumer.

Coachmen offers a wide variety of recreational vehicle models and choices of standard and optional equipment; therefore, certain descriptions in this manual may not apply to your unit. Ask your authorized dealer, or see the current brochure for information on the availability of standard or optional equipment.

Thank you for selecting our product. The entire Coachmen Industries family strives to merit your confidence.

JOIN THE INTERNATIONAL COACHMEN CARAVAN

The International Coachmen Caravan is your owners' club. It is designed to help you get the most pleasure from owning a Coachmen recreational vehicle. With your membership you'll receive:

MEMBERSHIP PACKAGE: The first benefit a member receives is a complete Caravan Identification Package. It includes a membership card, Coachmen Caravan decals and unit numbers. These are all-important to identify you as a full-fledged Caravanner eligible for all other Caravan benefits.

PERSONALIZED TRIP ROUTING SERVICE: We'll tell you the best way to go. Let us plan the itinerary that leads to your fun and traveling pleasure.

MAGAZINE DISCOUNTS: Save on a variety of America's popular subscriptions. The magazines about camping, traveling and the great outdoor world are especially right for you and your lifestyle - and so are the savings!

CARAVAN TRIPS: Hit the Caravan trail. It's the high road to adventure all year long. Interesting places and events are a big benefit of Caravan membership. There's so much to see and do when you're a member of the Caravan. The professional Caravan staff is constantly striving to develop outstanding tours and events. Traveling to special places with a Caravan of friends is a memorable experience that families can enjoy together.

CARAVAN CAPERS: Catch the news that features you. Capers is the quarterly magazine that brings you news about Caravan members and chapters across the continent, information about forthcoming trips and

rallies, and a variety of timely articles about the wonderful world of Coachmen Caravan. Capers is the special edition that's right for you.

PETE'S MARKET: Pete's Market is the Caravanner's mail-order store. And it's stocked with a vast array of distinctive items to make your RV adventures more fun. Special decals, patches, clothing, accessories, jewelry and some featuring Pete, the Dalmatian, our symbol - all reasonably priced with discounts for Caravan members.

DISCOUNT FILM PROCESSING: Capture those beautiful memories on film. And see the sights again when you take lots of pictures of your Caravan trips and other RV travels. Mail in your film to Caravan's special discount film processing center.

CAMPGROUND DISCOUNT PROGRAM: We have Campgrounds all over the U.S. and Canada that will give active Caravan members a camping discount. All you need to do is present your Caravan Membership Card at the check-in counter of those Campgrounds listed in the Campground Directory. Staying at about 10 campgrounds listed will make up for the cost of your yearly dues.

continued on back

SUBSEQUENT OWNER INFORMATION

If you are the second or subsequent owner of this recreational vehicle, it is important that you notify Coachmen RV of your name, address, date of purchase and the Serial Number of your RV. This information is vital for Coachmen RV to maintain up-to-date records of current ownership. You also may be entitled to the remainder, if any, of the warranty coverage. See the warranty explanation in the WARRANTY section of this manual. Complete the form below, clip it, and mail it to Coachmen RV Company.

Date of Purchase _____ RV Serial No. _____

Name of Former Owner _____

Your Name _____

Address _____

City _____ State _____ Zip _____ Phone No. _____ / _____

INTERNATIONAL COACHMEN CARAVAN MEMBERSHIP APPLICATION

Name _____ Spouse's Name _____

Occupation _____ Address _____

City _____ State _____ Zip _____

Phone (____) _____ - _____ Ham Call Letters _____

Previous Caravan Member? Yes No
International No. _____ Expires _____

Type of Unit _____ Length of Unit _____

Children's Name and Date of Birth 1. _____

2. _____ 3. _____

4. _____ 5. _____

Referred by _____

1 Year \$18.00

2 Years \$30.00

3 Years \$43.00

Bill Me

CAMPGROUND MANUAL DISCOUNTS: Take the scenic route! It's fun and it's easy-when you have your guidebook, available at a special price, for RV campgrounds.

LOCAL, STATE AND DISTRICT ACTIVITIES: Enjoy get-togethers and outings with other Caravanners throughout the year. In addition to International Caravan trips and rallies, you can enjoy your local, state and district Caravan Chapter activities too! There's always something exciting to plan and attend.

ANNUAL INTERNATIONAL CARAVAN RALLY: Come and share your good times with fellow Coachmen travelers.

KEY RETURN: If you loose your key ring identified with a special key tag number and the keys are found and dropped in a mail box, they will be returned to you through your Caravan office.

MEMBERSHIP DRIVE AWARDS: There is an excellent awards program with many awards available for bringing your friends into the International Coachmen Caravan as members. You can receive a lifetime membership, rally and trip discounts. Details and awards break down will be in your membership packet.

ICC MASTER CARD: As you support the Caravan, you help yourself. Caravan MasterCard special benefits include; No annual fee, Low 16% A.P.R., 25-day grace period on purchases, Automatic common-carrier

travel insurance of \$100,000 at no additional cost, Access to more than 23,000 CIRRUS network automated teller machines in more than 3,000 cities across the U.S. and Canada - fast cash - 24 hours a day - every day-added recognition for the Caravan whenever your card is used.

VISA OR MASTER CARD ACCEPTED: Membership Fees, Pete's Market, International Rally Fees, Coachmen Caravan Trip Fees.

EMERGENCY ROAD TOW SERVICE: You have available at a very low price an emergency Road program that covers not only your RV, but your tow vehicle or vehicle being towed.



To join the Caravan, complete, clip and mail the Membership Application, to the International Coachmen Caravan, P.O. Box 30, Middlebury, IN. 46540.

PLACE
STAMP
HERE



***SUBSEQUENT OWNER**

PLACE
STAMP
HERE

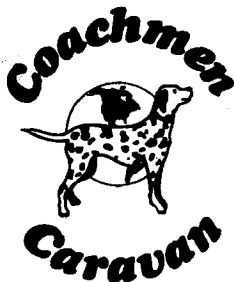

INTERNATIONAL COACHMEN CARAVAN
P. O. BOX 30
MIDDLEBURY, INDIANA 46540

***NEW MEMBERSHIP**

Table of Contents

APPLIANCES & ACCESSORIES	21	INTRODUCTION	9
Range, Range Hood, Oven	21	INSURANCE	9
Water Heater	22	LEVELING	10
Furnace	24	LP GAS SYSTEM	19
Refrigerator	24	Climate Differences	20
TV Antenna	26	Regulator/Changeover	20
Monitor Panel	26	Regulator Pressure	20
APPLIANCE IDENTIFICATION FORM	38	Regulator Freeze Ups	21
BASIC SYSTEMS	16	Filling LP Gas Bottles	20
Electrical System	16	LICENSES	9
Fresh Water System	17	LIVING AREA	15
Drainage/Sewer System	18	LOADING	10
LP Gas System	19	MAINTENANCE	36
CAMPER LOADING	10	MAINTENANCE SCHEDULE	37
CAMPING	14	PICKUP TRUCK SELECTION	9
DRAINAGE/SEWER SYSTEM	14	PRE-TRAVEL CHECK	32
Toilet	14	STORAGE	27
Holding Tanks	14	TRAVEL PREPARATIONS	11
DRIVING	13	TRAVEL PREPARATION CHECKLIST	33
Braking	14	TROUBLE SHOOTING	34
Clearance	13	VISITING CANADA OR MEXICO	12
Pulling into Traffic	13	WARRANTY	6-7
Passing	14	WEIGHING	11
Downgrades	14	WINTERIZATION	27
Upgrades	14		
Parking on a Grade	14		
Freeing a Stuck Vehicle	14		
EXTERIOR COMPONENTS	41-43		
FEDERAL STICKER	10		
FIRE SAFETY	28		
FRESH WATER SYSTEM	17		
City Water	17		
Water Tank	17		
Water Pump	17		
Sinks	17		
Leaks	18		

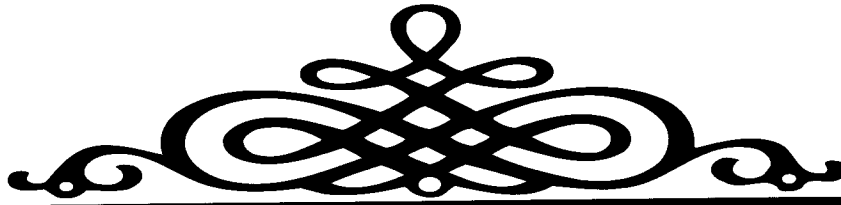

NEW RECREATIONAL VEHICLE LIMITED WARRANTY

COVERAGE PROVIDED

Coachmen Recreational Vehicle Company will, for one year from the initial retail purchase date, or for one year from the date the unit was first put into use, or for the first 15,000 miles of total use, whichever comes first, make repairs which are necessary because of defects in material or workmanship. We will repair or replace any defective part at no cost to you. Because of design changes and improvements, we may substitute parts or components of substantially equal quality.

TO OBTAIN SERVICE

For warranty service, take the product, at your expense, to an authorized Coachmen dealer or service center.

WHAT IS NOT COVERED

Automotive chassis, tires, batteries, and optional television sets or generators which are warranted separately by their manufacturers.

Damage such as that caused by misuse, abuse, collision, alterations, lack of proper maintenance, improper repairs.

Normal deterioration or wear of fabrics and carpeting.

Any product which is not used for its customary purpose.

Normal maintenance—it is the owner's responsibility to maintain the product in accordance with the instructions provided in the owner's manuals.

Any product which is not registered and normally used in the United States or Canada.

Any promises made by any person beyond those stated in this warranty.

WE SHALL NOT BE LIABLE FOR INCIDENTAL OR CONSEQUENTIAL DAMAGES, such as expenses for transportation, lodging, loss or damage to personal property, loss of use of your product, inconvenience, or loss of income. Some states do not allow exclusion or limitation of incidental or consequential damages, so the above limitation of exclusion may not apply to you.

* * * * *

IMPLIED WARRANTIES, INCLUDING ANY WARRANTY OF MERCHANTABILITY OR FITNESS FOR A PARTICULAR PURPOSE, ARE LIMITED IN DURATION TO THE TERM OF THIS WRITTEN WARRANTY. Some states do not allow limitations on how long an implied warranty lasts, so the above limitation may not apply to you.

This warranty gives you specific legal rights, and you may also have other rights which vary from state to state.

We want you to be satisfied with your new product. For further help or information, contact: COACHMEN RECREATIONAL VEHICLE COMPANY, SERVICE DEPARTMENT, P.O. BOX 1000, MIDDLEBURY, INDIANA 46540.



OUR WARRANTY

GENERAL—Your new recreational vehicle is backed by our position as an industry leader, achieved through decades of experience in producing RV's noted for their quality and dependability. Our one-year warranty demonstrates our confidence in our products and is a commitment to customers' continued satisfaction.

Every effort has been made to provide you with a safe, dependable recreational vehicle. Your RV complies with applicable federal and state regulations and the requirements of ANSI A119.2, the nationally recognized "Standard for Recreational Vehicles—Installation of Plumbing, Heating and Electrical Systems." The Recreation Vehicle Industry Association (RVIA) periodically inspects our production and assist in maintaining strict compliance with installation and safety standards for those systems. Similar periodic inspections of the systems are made by representatives of various states. You, the owner, must also perform periodic inspections of the systems and provide a program of preventive maintenance as described in the Owner's Manual and instruction booklets.

WARRANTY SERVICE—We recommend that warranty service be performed by the authorized dealer from whom you purchased your RV because of the dealer's continued and personal interest in your satisfaction. But if you are traveling or in the event that you move, service under the warranty will be performed by any of our authorized dealers. Whenever possible, make an appointment to avoid unnecessary delays.

Always Carry Your Owner Registration Card, which must be presented to obtain warranty service. The card is proof of purchase and provides the date of retail sale, which are necessary to determine warrantability. If you cannot locate an authorized dealer, contact our Service Department at the address on the back of this manual.

WARRANTY PERIOD—The warranty period shall be for 12 months and begin on the date your new recreational vehicle is purchased, or the first in-service date, whichever is first.

WHAT IS COVERED—The Manufacturer warrants to owners that an authorized Coachmen dealer will make repairs made necessary by defects in material or workmanship during the warranty period. Such repairs will be made without charge for parts and labor to the owner.

WHAT IS NOT COVERED—Our warranty does not cover the motor home chassis, tires, batteries or optional TVs and generators, repairs or adjustments required because of neglect, accident, misuse, failure to follow service and use instructions, normal wear and/or exposure, unauthorized repairs or unauthorized modifications to any part of the systems or body that might cause defective performance.

Your new recreational vehicle is designed as a temporary living quarters for recreational camping, travel or seasonal use and not as a permanent dwelling place. Usage as a permanent accommodation is a breach of warranty and we are not liable for any damage that results because of such misuse.

The manufacturer does not assume responsibility for loss of use of the recreational vehicle, loss of time, inconvenience or expenses due to equipment failures (refer to the warranty statement for other exclusions and limitations).

OTHER WARRANTIES—Be certain to complete and submit to the appropriate manufacturers the warranty forms for tires, batteries, chassis and optional TVs and generators, which are not covered by our one-year warranty. If service or parts are required for these products, please refer to the furnished list of factory-authorized service centers. If the list is not available, write or call the manufacturer concerned to obtain the location of the nearest authorized service center.

OWNER RELATIONS—Owner satisfaction and goodwill are of primary concern to us. We recognize that our continued success as a leading manufacturer of recreational vehicles depends upon your complete confidence in our products and service. A pleasant and effective relationship through our dealers is as important as maintaining the technical excellence of our product. Your authorized dealer will assist you in providing service, maintenance, selection of options and instructions concerning the operation of your recreational vehicle.

Occasionally, a warranty or service matter may not be handled to your satisfaction. Often it is the result of a misunderstanding and can be resolved at the dealer level. Discuss the situation with the dealership management. If you cannot find satisfaction at the dealer level, we invite you to contact our Customer Service Department, where we will make every effort possible to find an agreeable solution. In most instances, we will eventually refer you back to the local dealer with our recommendations.

Write or telephone Customer Service at P.O. Box 1000, Middlebury, IN 46540, 219/825-9350.

IMPORTANT SAFETY REGULATIONS

... please read carefully.

LP GAS SYSTEMS AND APPLIANCES

The manufacturer of this recreational vehicle is required to furnish the following consumer information as provided by the National Fire Prevention Association and the American National Standards Institute. The information and warnings found here may also be found in other sections of this Owner's Manual. Please see sections titled "Liquid Petroleum Gas System" and "Appliances" for other safety and operating information.



LP gas containers shall not be placed or stored inside the vehicle. LP gas containers are equipped with safety devices which relieve excessive pressure by discharging gas to the atmosphere.



It is not safe to use cooking appliances for comfort heating. Cooking appliances need fresh air for safe operation. Before Operation:

1. Open overhead vent or turn on exhaust fan, and,
2. Open window.

This Warning Label has been located in the cooking area to remind you to provide an adequate supply of fresh air for combustion. Unlike homes, the amount of oxygen supply is limited due to the size of the recreational vehicle, and proper ventilation when using the cooking appliance(s) will avoid dangers of asphyxiation. It is especially important that cooking appliances not be used for comfort heating as the danger of asphyxiation is greater when the appliance is used for long periods of time.



Portable fuel-burning equipment, including wood and charcoal grills and stoves, shall not be used

inside this recreational vehicle. The use of this equipment inside the recreational vehicle may cause fires or asphyxiation.



Do not bring or store LP gas containers, gasoline, or other flammable liquids inside the vehicle because a fire or explosion may result.

A warning label has been located near the LP gas container. This label reads: DO NOT FILL CONTAINER(S) TO MORE THAN 80 PERCENT OF CAPACITY.

Overfilling the LP gas container can result in uncontrolled gas flow which can cause fire or explosion. A properly filled container will contain approximately 80 percent of its volume as liquid LP gas.

The following label has been placed in the vehicle near the range area:

IF YOU SMELL GAS:

1. Extinguish any open flames, pilot lights and all smoking materials.
2. Do not touch electrical switches.
3. Shut off the gas supply at the tank valve(s) or gas supply connection.
4. Open doors and other ventilating openings.
5. Leave the area until odor clears.
6. Have the gas system checked and leakage source corrected before using again.

LP gas regulators must always be installed with the diaphragm vent facing downward. Regulators that are not in compartments have been equipped with a protective cover. Make sure that regulator vent faces downward and the cover is kept in place to minimize vent blockage which could result in excessive gas pressure causing fire or explosion.

INTRODUCTION

Congratulations on the purchase of your new RV. We sincerely thank you for choosing our product. To help you enjoy your new RV, you'll find in this owner's manual many useful tips for camping trips as well as basic operation and maintenance information for your RV's systems and appliances.

TRY A SHORT TRIP FIRST. The experience you will gain from this will help make your future RVing more enjoyable.

To complement the standard and optional equipment you've chosen for your unit, there are many other accessories available. You may wish to use your unit several times before you invest in these accessories. What may be a necessity for one RV owner could prove to be of no value to you. Remember, your dealer is always ready to help and advise you.

We go into great detail in this manual and for good reason. If you are a first-timer, we want you to learn to operate your RV correctly, to be able to use its components, appliances and any optional equipment in the most efficient manner.

At first glance, you may be overwhelmed by all the detail. But after you've used your new RV a couple of times, you'll be able to perform all the checks, start-ups and systems in much less time than it takes to read our instructions.

If you're a veteran RV owner, you know that things change and a quick review of this manual will bring you up to date on what's new.

So read on. Happy camping!

Note: *Because of the variety of models we offer, your RV may not have all of the components illustrated or described in this owner's manual. Ask your dealer for details concerning the specifics of your unit.*

LICENSES

Vehicle licensing laws vary from state-to-state. Check with your state license bureau or the nearest licensing branch office for the requirements of your state. Be sure to renew your driver's license if it has expired or will expire during your trip.

In the event that the truck camper you have purchased obscures the license plate on your pickup truck, a bracket has been installed on the rear of your truck camper for its relocation.

INSURANCE

Personal liability, property damage, collision and theft of contents may be features of your automobile insurance policy that apply to your RV. Talk to your insurance agent about the details of your coverage. Always carry your insurance policy and/or card with you when you travel.

PICKUP TRUCK SELECTION

Selection of a proper pickup truck is essential. To estimate the total cargo load that will be placed on a truck, add the weight of all passengers in the camper, the weight of all supplies, tools, and all other cargo, the weight of installed additional or optional camper equipment, and the manufacturer's camper weight figure. Select a truck that has a cargo weight rating that is equal to or greater than the total cargo load of the camper and whose manufacturer recommends a cargo center of gravity zone that will contain the camper's center of gravity when it is installed.

ENGINE SIZE

The engine must have enough horsepower to handle the pickup truck, the camper, passengers and all cargo. Most truck manufacturers offer a camper equipment package which may include: larger alternator and battery, heavier ply tires, sideview mirrors, heavier electrical wires, larger engine and transmission cooling systems. Consult the truck manufacturer's owner's manual for recommendations.

Note: *The use of heavier suspension components (springs, shocks, axles) or heavier ply tires DOES NOT increase the weight ratings printed on the pickup truck's identification or certification plate. The Gross Axle Weight Rating (GAWR) or each axle is determined by the components within the axle system with the lowest load-carrying capacity.*

ENGINE EXHAUST

Check the location of the exhaust pipe. It must be long enough to clear the pickup truck body and the camper unit.



Failure to check the location of the exhaust pipe or perform an occasional inspection of the exhaust system may result in asphyxiation of the occupants of the camper.

DUAL WHEEL PICKUP TRUCK

If you own or plan to purchase a dual wheel pickup truck, you also must have dual wheel mounting brackets, which are available from your dealer. These brackets compensate for the added width of the rear fenders by positioning the jacks farther from the truck body and allowing the fenders to easily clear the jacks.

BUMPER

In some cases, the rear bumper of the truck will restrict the use of the termination system and the entrance steps. In these instances, it is recommended the rear bumper be removed.

CENTER OF GRAVITY

Center of gravity is measured from the front lower wall of the camper. The camper's center of gravity point must be within the pickup truck's cargo center of gravity zone. A picture showing the location of the longitudinal center of gravity of the camper may be found in this manual. Accuracy is within 2 inches under the loaded conditions specified on the certification label on the camper.

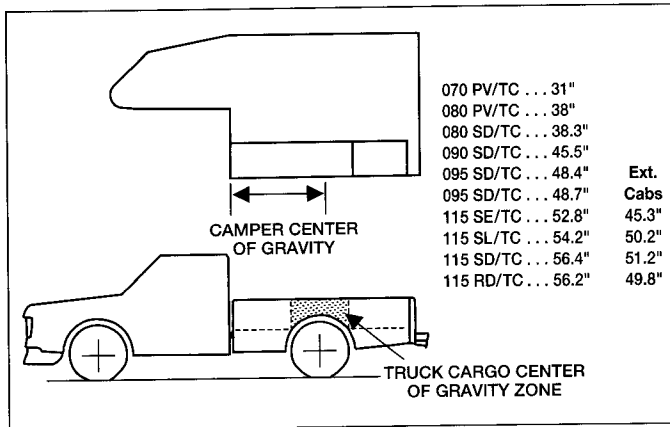

CAMPER CENTER OF GRAVITY
Measured from T-wall back

CAMPER LOADING

Do not load or unload on a windy day. The amount of wind that is dangerous depends on your exposure, weight of camper, etc. Only unload or store your camper on level ground. The jacks are only to be used to unload, load or steady your camper. Never use the jacks to store your camper. Inspect and maintain the jacks regularly. Do not extend any jack beyond the maximum extension indicator. This will severely affect the stability of the camper and may damage the jack. Do not place blocks under the jacks for additional ground clearance.

To load camper, back the truck up to the camper. The camper floor must be above the pickup truck's bed before it can be loaded. When raising the camper, always keep the front of the camper level with, or higher than the rear. Never get either end, or side, of the camper more than 6" out of level. If the camper is equipped with four jacks, they must be used in pairs—front ones first, then the rear. Extend the first jack (front) 4", then raise the other front jack the same. Repeat this procedure with the rear jacks, keeping camper as level as possible. Raise each jack no more than 4" at a time. Once the camper floor clears the truck, slowly back under the camper. Use extreme care not to hit any of the jacks or the camper with the truck. If the camper begins to move, stop immediately and locate the problem.

After the truck is under the camper, lower each jack no more than 4" at a time, beginning with the rear jacks, until the camper is resting securely on the truck. With hydraulic jacks, carefully open the release valve on one of the rear jacks and leave open. Then open the other

rear jack and lower 4". Close release valves on both jacks.

Repeat procedure with front jacks. Continue procedure until camper is securely resting on truck. Retract jacks for travel. With crank type tripod jacks, loosen both mounting bolts and remove one of the bolts. Swing leg up and extend through the holder. Reinstall and retighten bolts. For extended storage it is recommended that both bolts be removed and the jack be positioned so as not to allow water to accumulate in the jack leg.

The camper must be secured to the truck with tie downs. Different styles are available. Your dealer will be able to advise you on which type will best fit your needs. When loaded plug the electrical pigtail into the camper's pigtail socket.

To unload camper from the truck, simply reverse the loading procedure. On hydraulic or ball screw jacks, it is recommended that a 6" square piece of 1/2" plywood is placed under the jack foot. Be sure not to extend any jack more than 4" at one time. The jacks should then be lowered to their lowest position, or the camper should be set on a supporting platform before attempting to enter the camper.

Instructional information on the jacks is supplied with the owner packet. Please refer to the jack manufacturer's manual for additional information.

FEDERAL STICKER

Found on the road side of your camper, the Federal Sticker lists the serial number and the weight of the camper when it is equipped with standard item, water, LP gas and refrigerator or ice box. The weights of additional or optional equipment are listed on Page 31. This camper conforms to all applicable federal motor vehicle safety standards in effect at the date of manufacture. Your pickup truck will also have a Federal Sticker.

LOADING

When loading this camper store heavy gear first, keeping it on or close to the camper floor. Place heavy things far enough forward to keep the loaded camper's center of gravity within the zone recommended by the truck manufacturer. Store only light objects on high shelves. Distribute weight to obtain even side-to-side balance of the loaded vehicle. Secure loose items to prevent weight shifts that could affect the balance of your vehicle. A properly loaded vehicle will handle more safely. You also will conserve gasoline and prevent excessive wear on your pickup truck's automotive system if the unit is not overloaded. You may not want to load your camper to its capacity before leaving on your trip so that you may have room for purchases you may make. Store items acquired during a trip forward of the pickup truck's rear axle. We recommended that you weigh your pickup truck and camper again if you add more cargo.

MFD. BY:					DATE
INC. VEH. MFD. BY:					DATE
	GAWR LB	TIRES	PSI/COLD SINGLE	PSI/COLD DUAL	RIMS
FRONT					
INTER-MEDIATE					
REAR					
GVWR LB	MODEL NUMBER				
TYPE:	VEHICLE I.D. NUMBER				
THIS VEHICLE CONFORMS TO ALL APPLICABLE FEDERAL MOTOR VEHICLE SAFETY STANDARDS IN EFFECT IN:					

FEDERAL STICKER

WEIGHT DETERMINATIONS

It is extremely important that you weigh your pickup truck prior to leaving on a trip to determine whether your cargo load is within the allowable limits for the various suspension components. When the truck camper is loaded, drive to a scale and weigh the front and the rear wheels separately to determine axle loads. The load on an axle should not exceed its gross axle weight rating (GAWR). The total of the axle loads should not exceed the gross vehicle weight rating (GVWR). These weight ratings are given on the vehicle certification label that is located on the left side of the vehicle, normally the dash panel, hinge pillar, door latch post, or door edge, next to the driver on trucks manufactured on or after January 1, 1972. If weight ratings are exceeded, move or remove items to bring all weights below the ratings.

DEFINITIONS

GAWR—The allowable weight, including cargo and passengers, which can be safely supported by each axle.

GVWR—The maximum permissible weight of your pickup truck, including cargo, all options and passengers.

GVW and GAW—These are found by weighing the vehicle fully loaded. GVW is the actual weight of the pickup truck and all standard and optional equipment, cargo and passengers. GAW is the portion of the fully-loaded vehicle which is transferred to the axle(s).

You can weigh your vehicle at a grain elevator, sand and gravel dealer or government weighing station (they are listed in the yellow pages of your telephone book). The small fee involved is a worthwhile investment.

WEIGHING

STEP 1—Drive only the front axle of the pickup truck onto the scale. The load of the axle should not exceed the front GAWR listed on the pickup truck's Federal Sticker.

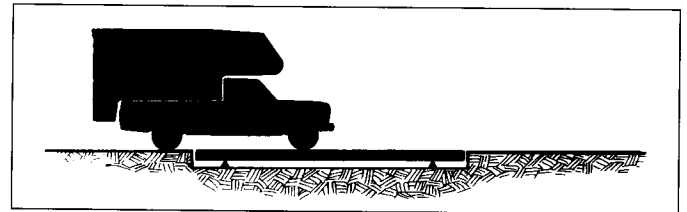

FRONT GROSS AXLE WEIGHT

STEP 2—Pull forward so that the front and rear axles are on the scale. This figure should not exceed the GVWR listed on the Federal Sticker.

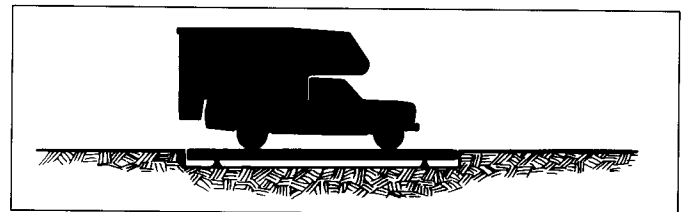

GROSS VEHICLE WEIGHT

STEP 3—Pull forward so that only the truck's rear axle is on the scale. The load on the axle should not exceed the rear axle GAWR listed on the Federal Sticker.

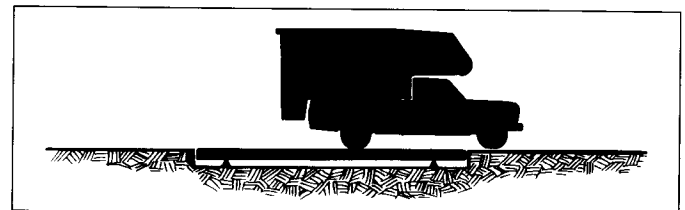

REAR GROSS AXLE WEIGHT

Note: If any of the weight ratings are exceeded, shift or remove a portion of the cargo and reweigh the pickup truck.

TRAVEL PREPARATIONS

It's always a good idea to **plan** your trips. Make arrangements for someone to check your house periodically while you're on your trip. Stop mail and newspaper

delivery. If you intend to be away for more than two weeks, request police surveillance for your house. Carry an extra set of vehicle and house keys with you on a separate key ring.

Fill your fresh-water tank before leaving. When traveling in winter, however, don't fill the water tank until the interior of your unit is thoroughly warmed or until you reach your destination.

Decide on the various items of equipment, clothing, food and other supplies you'll need for the length and destination of your trip.

Each moment you spend loading your RV is time you lose from the length of your stay. To reduce loading time, stock your RV with a supply of plastic or paper dinnerware, stainless steel or plastic flatware, pots, pans, towels and bedding. Try to use paper, plastic and aluminum whenever possible. They are lighter and less likely to break when the vehicle is moving. If you are planning an extended trip, pack only enough food for two or three days; you can replenish your supply along the way. Don't try to take enough food for the whole trip. Plan meals so that fresh or refrigerated items are used before they spoil. Keep a basic supply of seasonings (sugar, salt, pepper, spices) in your RV. See APPENDIX B: TRAVEL PREPARATION CHECKLIST for more tips on what to pack for your trip.

GENERAL DRIVING CHECKS

For your safety, make certain that the following items have been checked and rechecked before you take your RV on the road. Be sure to read APPENDIX A: PRE-TRAVEL CHECK for additional driving checks.

Jacks—The jacks must be **raised and secured** in their proper place.

Lights—The following lights should be tested on both the RV and the pickup truck: brake lights, warning lights, flashers, clearance lights, taillights, vehicle headlights. Clean all lens covers.

Pigtail—The pigtail should be connected properly to the tow vehicle's electrical harness.

Rearview Mirrors—Adjust all rearview mirrors so that the driver can see the right and left side of the unit.

IMPORTANT DOCUMENTS

Always carry your vehicle registration, insurance policy card(s) and owner warranty registration card. If you are borrowing a vehicle, it is best to have with you a notarized letter of approval from the owner authorizing you to be in possession of the vehicle.

COURTESY

Common courtesy will help make your stay more pleasant. Campsites often are close together and loud noises may disturb neighboring campers. Follow the posted rules of the campsite. Open fires might not be permitted. If you are permitted to build a campfire, clear the area of all flammable materials; never leave a campfire unattended, and always make certain the embers

are completely extinguished before leaving the campfire or before going to sleep. Good RVers are proud of the fact that they always leave a campsite cleaner than they found it.

TOURIST INFORMATION

Obtain current road maps and tourist information for each state you'll visit or drive through. You also may want to purchase a tourist guide book and/or a campground directory.

If you will be visiting federally-operated national parks, monuments and recreation facilities, you might find the Golden Age Passport and/or the Golden Eagle Passport useful. These passports can help families cut expenses at areas where fees are involved.

GOLDEN AGE PASSPORT is a free lifetime pass for persons age 62 and over. It covers all admission fees and includes a 50 percent discount on usage fees (except fees charged by privately operated concessions). This passport is available only at park service offices and at parks where entrance fees are charged. It cannot be obtained through the mail or at post offices. To obtain the Golden Age Passport, you will need proof of age, such as a driver's license. (Medicare cards are not accepted as proof of age.) If you do not have adequate proof of your age, be prepared to sign an affidavit swearing that you are at least 62 years of age.

GOLDEN EAGLE PASSPORT is designed for persons who plan to visit in a single year several parks or federally-operated facilities. It covers all admission charges, but does not cover usage fees. It is good only during the calendar year in which it is issued. It may be purchased in person or through the mail from the National Park Service Headquarters, department of the Interior, Washington, D.C. 20240; at regional National Park Service offices, or at similar facilities where entrance fees are charged.

Both Golden Age and Golden Eagle Passports cover admission fees for passengers accompanying the permit holder. Where entry to the recreation facility is not by private vehicle, such passport covers only the permit holder and the permit holder's immediate family.

VISITING CANADA OR MEXICO

The information in this section is general and is subject to change by the Canadian or Mexican government. For specific information, including rules for re-entering the U.S., as well as points of interest and campsites, contact the consulate nearest the point at which you plan to enter the country.

Passports or visas are not required for entry into CANADA or MEXICO. You must, however, carry your birth certificate, voter registration card, baptismal certificate or similar proof of identity when entering one of these countries. Naturalized U.S. citizens should carry

their naturalization papers or other proof of citizenship. Persons under 18 years of age should carry a notarized letter from their parents or guardians giving them permission to travel in CANADA or MEXICO.

Note: A U.S. driver's license does NOT serve as proof of identity.

No special driver's license or permit is necessary in either country; but, renew your license if it has expired, or will expire during the trip. Proof of vehicle ownership is required at the border. If you are using some else's unit, you should have a notarized letter authorizing its use.

MEXICO

A tourist card is necessary for visiting in MEXICO if you will be staying more than 72 hours or travel more than 40 miles from the border. Cards can be obtained at the port of entry or from a Mexican consulate.

VEHICLES

MEXICO requires a vehicle permit for every self-propelled vehicle. The permit can be obtained only from Mexican Aduana (customs) offices upon presentation of tourist card, vehicle registration and title or notarized statement from owner. Your insurance policy is **not** valid in MEXICO. Temporary insurance must be purchased from Mexican companies (usually offices are located near the border).

CB RADIO

MEXICO currently prohibits the use of CB radios.

HUNTING AND FISHING

Hunting and fishing laws in MEXICO are extremely complicated. To request information, contact:

Secretaria de Comunicaciones
Estados Unidos Mexicanos
Mexico DF

DOGS AND CATS

MEXICO requires a certificate signed by a licensed veterinarian. The certificate should describe the pet and show that the pet has been vaccinated for rabies within the past six months. A fee is charged for the required verification of the certificate by a Mexican consulate.

CANADA

VEHICLES

CANADA requires a Canadian Non-Residential Interprovincial Motor Vehicle Liability Insurance card, which is available only from U.S. agents. All provinces in CANADA require evidence of financial responsibility if visitors are involved in an accident. Limits vary from province to province. Contact your insurance agent for details.

CB RADIO

CB radio operation in CANADA requires a temporary license. To obtain such a license, write to:

Regional Director
Telecommunications Regulation Branch
Department of Communications
20th Floor
2085 Union Avenue
Montreal, Quebec H3A 2C3
Canada

HUNTING AND FISHING

Revolvers, pistols and fully-automatic firearms are prohibited in CANADA. Each province has its own laws and licensing requirements. You must provide a written description and the serial number of each gun at the border. A license must be obtained from the province in which you intend to hunt or fish. Further information can be obtained by writing to the Department of Lands and Forests, Wildlife Branch, in the province you intend to visit.

DOGS AND CATS

CANADA requires a certificate signed by a licensed veterinarian in the U.S. or Canada stating that your dog has been vaccinated for rabies within the past 12 months. The certificate must contain a description of the dog and date of vaccination. Puppies under three months need no certificate. There is no restriction on the entry of healthy cats.

DRIVING

Get to know how your pickup handles with the added weight of your RV. The brakes and steering operation will be different. Before leaving on a trip, practice making right and left turns, braking, backing and accelerating. Your RV is designed to travel at maximum legal highway speeds under ideal conditions. Under less than ideal conditions, your vehicle should be operated at reduced speed and it should never exceed the posted legal speed limits. Before you travel be sure to read APPENDIX A: PRE-TRAVEL CHECK in this manual. Below are tips to help you.

CLEARANCE

Be sure to read "Clearance Height" signs on overpasses, drive-through windows, etc. Watch out for overhanging tree branches, awnings or similar obstructions that can damage your vehicle's roof or roof-mounted equipment and accessories. Check with your dealer for clearance measurements of the unit.

PULLING INTO TRAFFIC

Check for oncoming traffic in all directions. Signal before entering the flow of traffic. Always accelerate slowly and smoothly; the added weight of your RV

makes quick acceleration not only difficult but potentially unsafe.

PASSING

Avoid sudden maneuvers when passing a slower-moving vehicle. Remember that additional time and distance are required to pass safely. Wait until the road is clear of oncoming traffic for at least 1/2 mile. Check the outside rearview mirrors and signal lane changes before passing other vehicles. When you have safe clearance, signal lane change and return to your original lane.

BRAKING

Allow a safe distance to stop; follow no closer than one vehicle length for each 10 mph. Pump the brake pedal lightly to stop on wet or icy roads. If you start to slide, turn the wheel in the direction of the slide. DO NOT "slam on" the brakes—a panic stop will increase the slide.

DO NOT rest your foot on the brake pedal while driving. "Riding" the brakes in this manner may cause overheating, excessive lining wear and possible brake failure.

UPGRADES

To avoid engine overheating when climbing a steep grade, reduce speed and shift the transmission to a lower gear.

* CAUTION *

DO NOT exceed the truck manufacturer's recommended speed limit in lower gears—excessive engine speed will overheat the transmission, which may cause early transmission failure.

DOWNGRADES

When you are going downhill, reduce your speed and shift the transmission to a lower gear to assist in braking on long or steep downgrades.

PARKING ON A GRADE

Parking vehicles on an upgrade or downgrade is not recommended. If it is necessary in an emergency, always apply the brakes and have a passenger place wheel chocks behind the tires of your truck. When in place, slowly release brakes until the unit is stopped by the chocks. Apply parking brake and shift transmission into PARK position (place manual transmission vehicles in gear).

FREING A STUCK VEHICLE

To pull your unit out of the snow, sand or mud, apply slight pressure to the accelerator pedal and move the gear selector lever rhythmically between first gear and Reverse (R). If possible, keep the front wheels pointed straight ahead. Avoid sharp turns. Once the unit

starts to move, do not stop until it is on firm ground.

* CAUTION *

DO NOT race the engine or spin the wheels; prolonged efforts to free a stuck vehicle may result in overheating and transmission and axle failure.

TOWING

Consult the truck manufacturer's owner's manual for recommendations on towing.

TIRE CHANGE

Change a tire on as level and firm a surface as possible. If you are on the roadside, activate the unit's hazard warning flashers. Apply parking brake and move transmission selector to the Park (P) position or place in gear. Set up flares and/or warning lights. See the your truck manufacturer's owner's manual for proper tire change instructions.

CAMPING

CAMPSITE SELECTION

There are many campground guides that will assist you in making your selection. Many campgrounds accept reservations, and during peak seasons, it is wise to make a reservation. If possible, arrive early so you can inspect and choose your campsite during the daylight hours.

During the winter months it is desirable to take advantage of natural windbreaks like trees, bushes or any similar type of windbreak. This will cut down the possibility of cold drafts that can affect the comfort level of your unit.

SET-UP

It is very important that your unit is level. This allows your refrigerator and drainage systems to operate properly (both function by gravity). To determine levelness, place a level on the bottom of the refrigerator's freezer compartment or in a normally level location inside the vehicle. You may wish to permanently attach levels (available at your dealer) on the front and/or back and sides of the RV. This will allow you to tell at a glance if you've stopped on a level site and will help speed the leveling process.

If the unit needs side-to-side leveling while loaded on the truck, you may make a step leveling tramp (Figure 4, page 41) using 1 x 6" or 2 x 6" boards of varying lengths. Pull the unit forward or back onto the leveling ramp until the tire(s) on the low side are level.

If your unit is a fold down model, please follow these steps.

1. Release all four roof latches.
2. Go inside of unit, take crank out of storage cabinet. Put handle in front bunk crank and turn clockwise, until roof is all the way up.
3. Put down safety latch on right system bar to secure roof. Located front of bunk on right side.
4. Go outside the unit and snap tent snaps to snaps on unit, all the way around.
5. If your unit has a shower, connect the shower curtain to the ceiling with snaps.
6. Connect vinyl pipe cover over drain pipe with velcro.



The loading jacks are designed to permit you to raise or lower the truck camper for placing it onto, or removing it from, the pickup truck bed. DO NOT occupy your truck camper when it is off the pickup truck bed unless you have made sufficient arrangements to ensure the stability of the unit (proper blocking under the body of camper).

LIVING AREA

TABLE

Insert table leg into base plate. Lower table support bracket onto the leg.

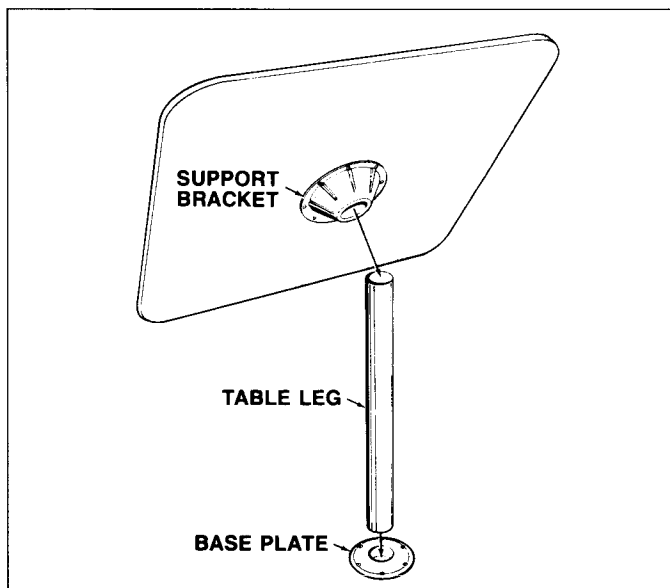

PEDESTAL TABLE

BEDS

U-SHAPE DINETTE

Lift pedestal table and remove leg. Remove center cushion. Place table on seat braces and slide inward.

Arrange cushions on top. Store center cushion and leg under table or in a closet.

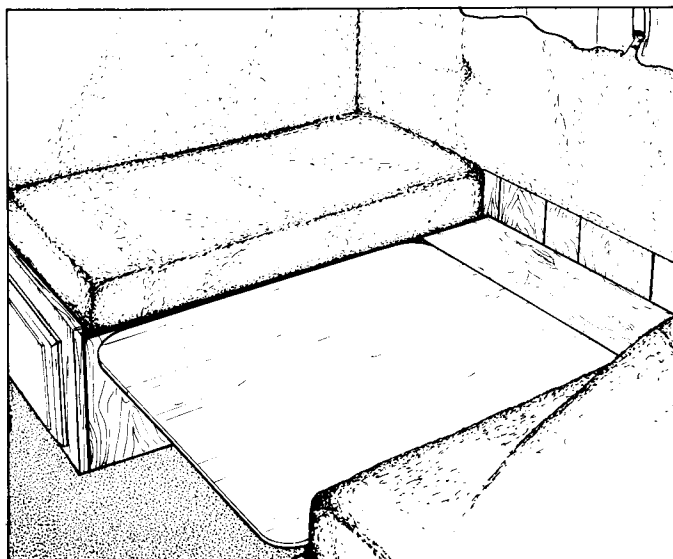

U-SHAPED BED

CABINET HIDE-A-BED

Open both end cabinet doors. Release latches (one is located at each end). Close the cabinet doors securely. Swing cabinet face down so that it rests on its supports. Position reinforcing boards on top of the cabinet face. Arrange mattress on top.

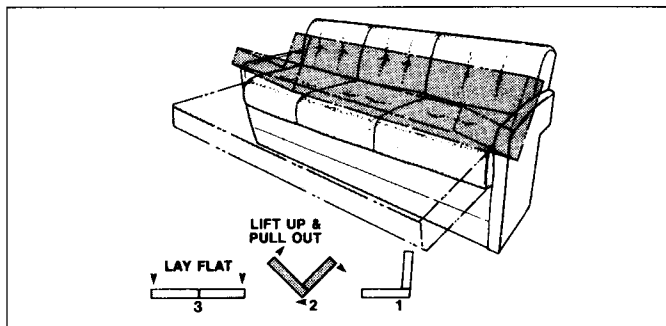

JACKKNIFE SOFA

AIR QUALITY/CONDENSATION

Condensation can be a problem in modern, tightly constructed, recreational vehicles. When the unit is tightly closed, especially in cold weather, the relatively-small air volume in the RV can absorb only a certain amount of moisture. When the saturation point is reached, the moisture is released in the form of condensation. (Certain amounts of condensation should be expected, especially on cool surfaces such as windows and metal door frames.) However, excess condensation can damage walls and ceilings. Bathing, dishwashing, appliances and unvented gas burners, all add moisture to the air. You can control this by allowing the moisture to escape to the outside. Use your roof vent when cooking; don't hang wet clothes in your unit to dry. In hot weather, air conditioning can help make you more comfortable because it removes excess humidity from the air, while lowering the air temperature.

BASIC UTILITY SYSTEMS

This section will describe the four basic utility systems found in your RV. They are: Electrical, Fresh Water, Drainage/Sewer and LP Gas. The following will familiarize you with their function, operation and simple maintenance. If a problem should develop with any of the four systems, contact your dealer for service.

ELECTRICAL SYSTEM

Your RV contains two (2) separate electrical systems: one 12-volt direct current (DC), similar to the one in automobiles, and one 120-volt alternating current (AC), similar to the one in homes. These systems provide you with power while you are camped or are traveling. The 120-volt system requires an external source of 120-volt electricity, usually a campsite or household receptacle or an auxiliary generator. The 12-volt electrical system is supplied by your automotive battery.

120-VOLT SYSTEM

The 120-volt system supplies power for the following through the power center: refrigerator, exterior receptacles, interior receptacles (used to operate regular household appliances), and optional roof air conditioner. The converter provides 12-volt power for all of the unit's 12-volt components. When the external 120-volt power cord is used, the power is connected directly into the main electrical service panel of the power converter and is distributed through circuit breakers.

SHORELINE CONNECTION

The Shoreline (Figure 7, Page 42) is a heavy-duty cable with a 3-prong grounding plug on one end, permanently attached at the other end, and connected to the power center. It can be pulled from its storage compartment through a hatch in the sidewall of your vehicle and connected to a matching receptacle. Some campsites and trailer parks still have two-slot outlets. If it is necessary to use a 3-to-2 adapter, be certain its grounding wire is fastened securely to the outlet grounding screw.

The 120-volt system is protected by the circuit breakers. If a circuit breaker opens, unplug the appliance(s) on that circuit, allow a short period for the breaker to cool, and rest the breaker. If the breaker continues to open, notify your dealer.

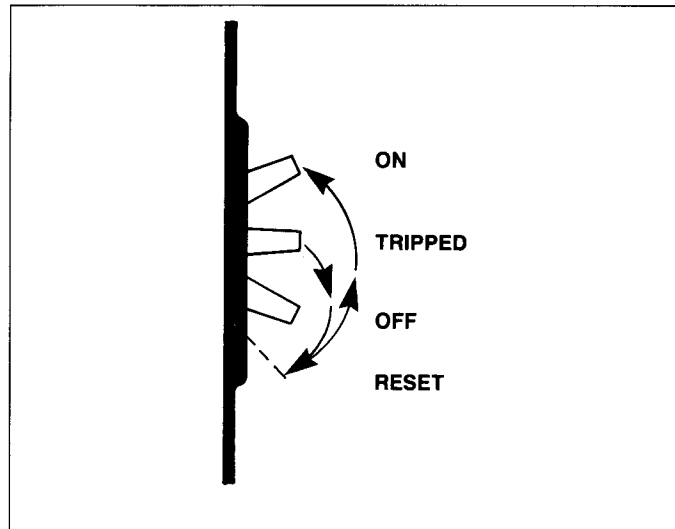

CIRCUIT BREAKER RESET

12-VOLT SYSTEM

The 12-volt system is powered by the automotive battery or 12-volt converter. To use the automotive battery, the electrical pigtail must be attached to your truck. This provides power to all exterior lights in addition to all inside RV 12-volt appliances. The optional 12-volt converter provides power to all inside appliances (lights, range hood, furnace blower, water pump, 12-volt receptacles, porch light and refrigerator). The refrigerator requires 12-volt power to run in the gas mode. The Shoreline (Figure 7, page 42), must be attached to run the converter.

CONVERTER

The power converter section of the power center transforms 120-volt AC into 12-volt DC to supply power to all of the 12-volt systems. Each 12-volt circuit is protected by a fuse in the power center. Turn the twist lock to open the door and check the fuses. A listing of the circuits is on the inside of the door. Some fuses protect circuits with more than one function; others may be for specific appliances.

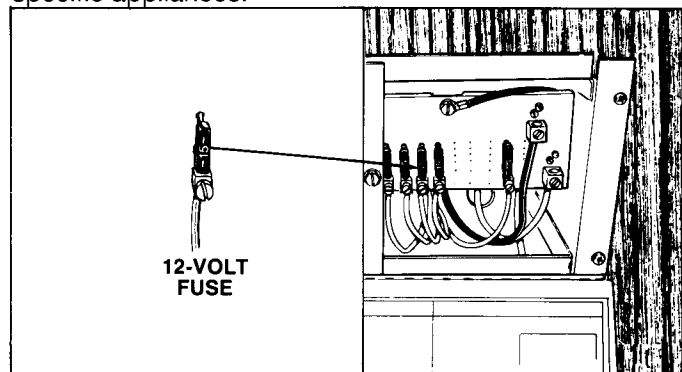

12-VOLT FUSE BLOCK

If a fuse is blown, turn off or unplug all appliances on that circuit. Replace the blown fuse with one of the same ampere rating. If the fuse continues to blow, notify your dealer. See the power center manufacturer's

manual for specifications and operation and testing procedures.

FRESH WATER SYSTEM

Fresh water for your unit is supplied either by the vehicle's fresh water tank or by an exterior pressurized source (city water).

The water heater (either match light or electronic ignition) is an LP gas appliance that heats water to a preset temperature. To fill the water heater when your unit is connected, simply turn on a hot water faucet. When water flows steadily, turn the faucet off.

CITY WATER

When using the city water hookup, the water tank and pump are bypassed. You cannot fill the water tank through the city water inlet. Connect a hose to a "city pressurized" water faucet and to the vehicle's fresh water inlet (Figure 8, page 40).

Although a common garden hose can be used to fill the water tank and connect to city water, long-time RVers recommend a hose specifically manufactured for this, available at your RV dealer.

Note: In areas where city water pressure exceeds 60 psi, you should use a pressure regulator. Excessive water pressure may damage lines and connections. See your authorized dealer for more details.

WATER TANK

Because of a variance in weight distribution, the water tank may be beneath a gaucho, dinette, bed or kitchen cabinet or under the floor of the unit.

To fill the water tank, open the door to the combination city/gravity water fill. Remove cap and vent plug for gravity water fill (figure 9, page 40). Use a hose or vessel to fill the water tank. Water will flow out of the water fill when the tank is full.

The water tank should be sanitized before you use it for the first time; after a period of nonuse; and whenever you suspect the tank is contaminated. To sanitize your water tank, first empty the tank and then use the following procedures:

1. Make 2-1/2 cups of liquid household bleach with 10 gallons of water. Pour the solution into your tank through the gravity water fill.
2. Turn the water pump ON, open the hot water faucet, wait until the water begins to flow, and then turn the faucet off. Do the same with the cold water faucet. Wait three hours.
3. Open faucets and line drains. Drain the entire system. Some solution will remain in the water heater.

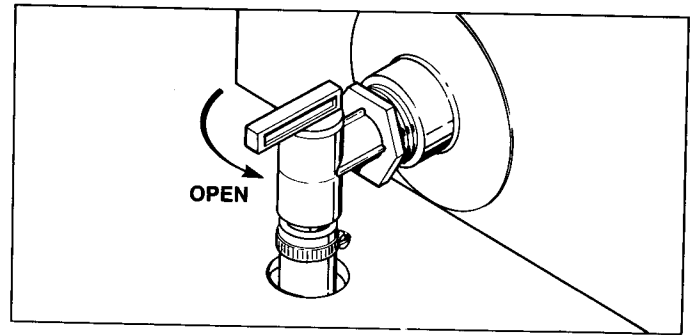

WATER TANK DRAIN

4. Insert a hose into the gravity water fill. Begin filling the tank. Open the hot water faucet. Be sure the water pump is on. Let the water run until the system is completely flushed. Do the same with the cold water faucet. The hot water faucet will need to run longer to completely drain the water heater.
5. If a chlorine taste lingers, flush the system with a vinegar and water solution (one quart of vinegar to five gallons of water). Wait two to three hours and then flush with fresh water.

WATER PUMP

The water pump is a 12-volt DC appliance that is activated by a switch on the monitor panel or a switch mounted in the kitchen area. The switch can be left on while camping. When you want water, simply open a faucet. The pump, which supplies water from the fresh water tank, will run only as long as is needed. If the pump fails to start when the switch is on, check the fuse located in the converter. If the pump continues to operate whether the faucets are opened or closed, check the water tank. It might be empty or there might be a leak in the system. If the city water is connected, the pump is not required.

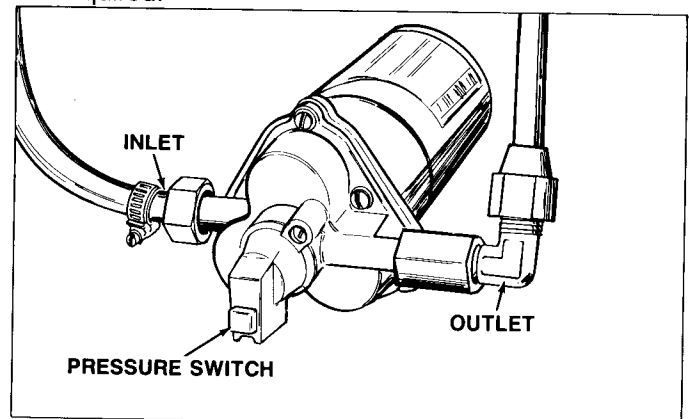

WATER PUMP

CARE OF SINKS, LAVATORY AND SHOWER

Clean the kitchen sink, lavatory and shower pan with a non-abrasive cleaner. Stainless steel cleaner may be purchased at most grocery stores. ABS cleaner, such as Aqua K-7, may be purchased from your dealer.

LEAKS

Traveling over bumpy or rough roads can cause pipe fittings to loosen. Check the pipe fittings in your unit regularly for signs of leakage.

DRAINAGE/SEWER SYSTEM

Your RV is equipped with a drainage sewer system that functions much the same as the one in your home. In most units, this system includes drain lines from the kitchen sinks, lavatory, tub/shower and marine type toilet to a gray-water holding tank and/or a sewage holding tank.

The drainage system also includes vents that carry odors (caused by drain water and waste) out through the roof. The drainage system vents also equalize the air pressure, which is necessary to maintain a water barrier against odors in the P-traps and to ensure smooth flow and escape for your drainage system.

TOILET

Flush the toilet before initial use and after emptying the holding tank. To help control odors, there are a number of toilet and holding tank treatment concentrates on the market. These chemical concentrates are available at your RV dealer.

To operate toilet, pull the black lever, which empties the bowl, forward (the "open" position) and hold until all contents are swept into the holding tank. Always hold the black lever in the "open" position for a minimum of three seconds. The black lever simultaneously activates the white lever. When you release the black lever, the bowl will automatically fill with water for the next use. To add more water to the bowl, pull the white lever forward.

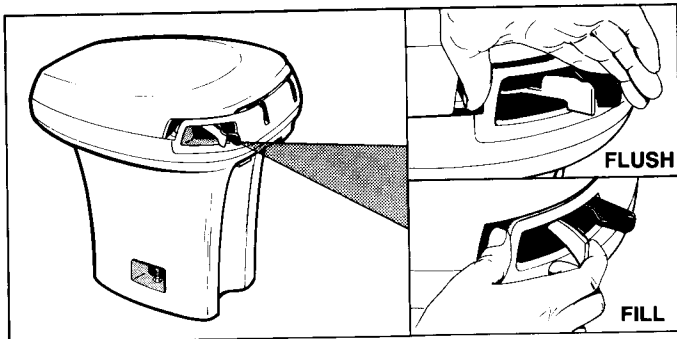

AQUA MAGIC IV TOILET

When you clean your toilet, do not use highly concentrated or highly acidic household cleaners (no scouring powder). If the slide valve does not move freely, apply silicone spray. To ensure proper operation and maintenance, refer to your toilet manufacturer's operating manual.

PORTA POTI

Before using, stand the unit up vertically on the front end with locking latch facing upward. Slide latch to unlock and separate the units.

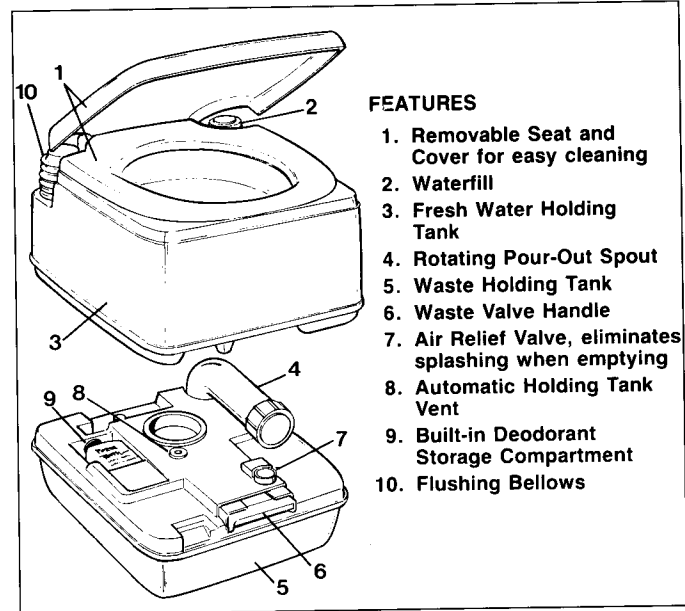

FEATURES

1. Removable Seat and Cover for easy cleaning
2. Waterfill
3. Fresh Water Holding Tank
4. Rotating Pour-Out Spout
5. Waste Holding Tank
6. Waste Valve Handle
7. Air Relief Valve, eliminates splashing when emptying
8. Automatic Holding Tank Vent
9. Built-in Deodorant Storage Compartment
10. Flushing Bellows

With the lower tank sitting flat, open the waste valve by pulling the handle out. Pour in a tank deodorant, and add a small amount of water to cover the tank bottom. Replace deodorant in its storage compartment and close the valve. Place the fresh water holding tank on top of the waste holding tank and slide the latch to lock the units together.

To add water to the bowl, push down flushing bellows. To flush after use, pull waste valve handle straight out, then press flushing bellows one or more times to rinse. Push the valve handle in to close and seal the waste holding tank.

Empty the toilet when the contents in the holding tank approach the level of the valve blade. Separate the units and carry the holding tank to any permanent toilet facility. Rotate the pour-out spout to the desired position and remove cap. Depress air relief valve while emptying. Rinse tank with water, replace cap, and repeat the above procedure to prepare for next use.

HOLDING TANKS

Most unit drainage/sewer system have two holding tanks: Gray Water and Waste (black) Water. The gray water holding tank collects water from the kitchen sink, lavatory and tub/shower. The waste (black) water holding tank is used to collect waste from the toilet. In some units, one tank collects both gray water and sewage waste.

To prevent unnecessary accumulation of solids in the waste holding tank, do not put facial tissues or similar products into the toilet. It is highly recommended that you use only bio-degradable toilet tissue available from your RV dealer. Holding tanks should be emptied frequently into a specified dumping station. Most campgrounds have dumping stations, often at each campsite, and many service stations and highway rest areas have waste dumping stations also. Before emptying the holding tanks, make sure your vehicle is level; emptying the holding tanks depends on gravity.

To empty the holding tank, remove the sewage drain hose from its storage area. Remove the cap from the termination outlet and connect the sewage drain hose.

While you are camped you may leave the gray water dump valve open only if the hose is connected and your campsite has a sewage hookup. Do not open the waste water dump valve until you want to empty the holding tank. If the waste water dump valve is left open, the rinse and flush water will run off and solids will be left to collect and harden in the bottom of the tank.

To drain a holding tank, pull out the dump valve slide handle (Figure 10, page 41). On some units it is necessary to unfasten or unlock a holding device before the slide valve handle can be pulled out. After the tank is drained, close the valve (if applicable, lock in place).

After emptying the waste holding tank, flush or pour about two gallons of water through the toilet and drain again. This flushes the tank and helps clean the drain hose. Repeat as necessary.

To empty the gray water holding tank, follow the same procedure used to empty the waste holding tank. A flushing may not be necessary. When the tank is empty push the dump valve handle in until it seats (if applicable, lock in place). Remove the hose, wash it and return it to its storage holder. Replace the termination cap securely.

It is recommended that you always drain the sewage waste holding tank first, and then the gray water tank. This assists in flushing and cleaning the termination valve and drain hose.

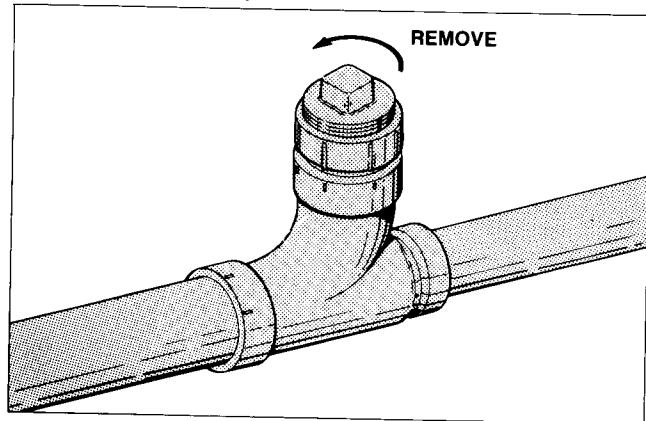

DRAIN CLEANOUT

DRAIN PIPING

If your unit does not have holding tanks it will have a drain pipe and termination outlet and cap (Figure 11, page 42). To drain, remove the termination outlet cap and attach the drain hose. Some campsites will have septic service for the disposal of gray water at each site. If the site is not so equipped, collect the gray water in a bucket or container and dispose of as required by park rules. To avoid contamination, use different buckets for fresh and drain water; mark or paint them for easy identification.

DRAIN CARE

Use clear water to clean exterior pipe surfaces. DO

NOT use harsh drain cleaner chemicals or solvents in the drains. Drain cleanouts are installed at intervals at intervals to facilitate drain line cleaning or unclogging. Use a wrench to remove and replace drain cleanout plug.

If you have a problem with clogged drain lines that you cannot easily solve it is recommended that you consult an authorized dealer.

LP GAS SYSTEM

The liquified petroleum (LP) gas system in your unit furnishes fuel for hot water, heat, cooking and refrigeration. LP gas provides a portable, efficient and inexpensive source of energy. It is stored inside a compartment on your truck camper.

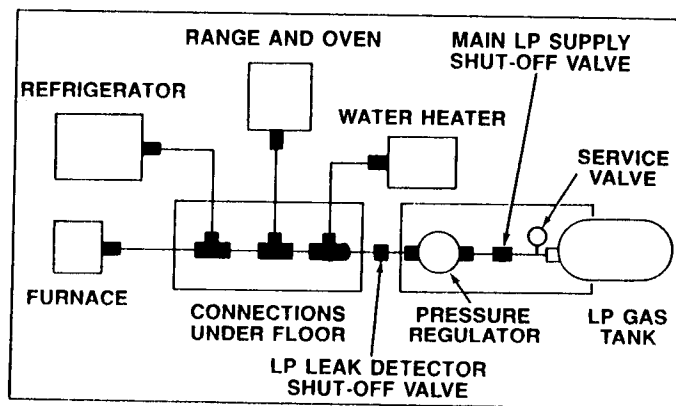

LP GAS SYSTEM (TYPICAL)

Under pressure in the tank, the LP gas turns to vapor; it is the latter that burns. Each bottle has a 20 percent liquid level valve that allows space in the tank for vapor expansion. **Never** overfill the bottle. The high pressure of the vapor in the bottle is reduced in two stages through a regulator (Figure 12, Page 42).

LP gas is usually propane or a blend of propane and butane. When you fill your tanks, be sure to use propane **ONLY**. Do not use butane or butane mixtures.

The LP gas system is designed and built to meet rigid standards, and it is tested before it leaves the factory. Your dealer also tests the system before it is delivered to you. Except for simple maintenance and occasional tightening of a connection, always take your vehicle to an authorized dealer for LP gas problems. Always have an authorized LP gas supplier fill your LP gas tanks.

LP gas burns readily and with intense heat. With proper care and maintenance, it is safe and efficient. There are, however, certain characteristics about LP gas you should know. LP gas is heavier than air and tends to collect in low pockets. As LP gas settles into any closed area, it displaces air and could cause suffocation if not detected. It also could create a fire or explosion hazard. In its natural state, LP gas is odorless. An additive gives it a distinctive mustard odor so that leaks can be readily detected. The following label has been placed in the vehicle near the range area:



If you smell or think you smell gas:

1. Extinguish any open flames, pilot lights, all smoking materials.
2. Do not touch electrical switches.
3. Shut off the gas supply at the tank. CLOSE valve(s) or gas supply connection.
4. Open doors and other non-electrical ventilating openings.
5. Leave the area until the odor clears, and
6. Immediately call your gas supplier, and have the gas system checked and leakage source corrected before using again.

Before using any LP gas appliance, read the respective manufacturer's operating instruction manual.

Note: LP gas containers should not be placed or stored inside the living area of a vehicle. LP gas containers are equipped with safety devices that relieve excess pressure by discharging gas to the atmosphere.

CLIMATE DIFFERENCES

The appliance will not function if the LP gas does not vaporize. Propane continues to vaporize down to 44 degrees Fahrenheit below zero. Liquid gas does not vaporize as rapidly in cold weather, so you may place too great a demand on your bottles' capacities in certain conditions. This can cause a refrigeration effect resulting in frosting of the bottle and regulator. Check with your dealer or LP gas supplier about the appliance demands that can be met by your bottle at various temperatures. Always have your LP gas supplier add anhydrous methanol before filling the tank in cold weather.

Propane has become the main type of LP gas used in RVs. It is recommended that you use only propane gas. The names of LP suppliers can be found in the Yellow Pages of your telephone directory under "Gas-Liquefied Petroleum-Bottled and Bulk." Many campgrounds now have LP fill facilities, as do some service stations.

To operate any LP gas appliance, the LP gas SERVICE valve (Figure 12, Page 42) must be open. When first used, or after a refill, there may be some air in the gas lines that will escape when you first open a range burner or similar LP gas valve. The air may extinguish your match or igniter the first time or two before you get ignition. Remember too, that when you close the bottles' SERVICE valve some of the gas will remain in the lines. To completely bleed the lines of gas, close the bottle's SERVICE valve and light a range burner to use up the excess. When the flame burns out, turn the range burner off.

REGULATOR/CHANGEOVER

Each pair of LP gas bottles will have a regulator. Double 20-lb. bottles have an automatic changeover.

With the automatic changeover, open the Service valves on both bottles. The bottle to which the arrow in the changeover knob points is the one in service. As long as there is fuel in the bottle, the full-empty indicator on top of the regulator will show white. When the bottle is empty, the automatic regulator will begin using fuel from the "reserve" bottle. When this happens, the full-empty indicator will change from white to red.

At this point, the empty bottle should be shut off and the indicator knob turned so that the arrow points to the bottle in service. The FULL-EMPTY indicator again will show white. The empty bottle may now be disconnected for refilling.

Check the indicator flag regularly to avoid running completely out of fuel. You also can check the volume of LP gas by weighing the bottle comparing the known weight of an empty and a filled bottle. The TARE (empty) weight is stamped on the LP gas bottle handle.

REGULATOR PRESSURE

Check the LP gas regulator at the beginning of each season or whenever a problem is indicated. Correct line pressure is 11 inches of water column. Your dealer or LP gas supplier can perform this check.

LP gas regulators must always be installed with the diaphragm vent facing down. Regulators that are not in compartments have been equipped with a protective cover. Make sure that the regulator vent faces down and that the cover is kept in place. This will minimize vent blockage that could result in excessive gas pressure and could cause a fire or explosion.

LP LEAK DETECTOR

Your LP gas leak detector is located at the base of an inside wall. Power is automatically supplied to the detector either from the truck pigtail, the 110 unit shore-line/convertor, or from the RV battery. It is designed to provide years of trouble-free service. The battery, if so equipped, should be disconnected for storage or periods of non-use, as the constant draw will drain the battery. If the alarm goes off, follow the instructions for "If You Smell Gas," or refer to the operating instructions provided by the manufacturer.

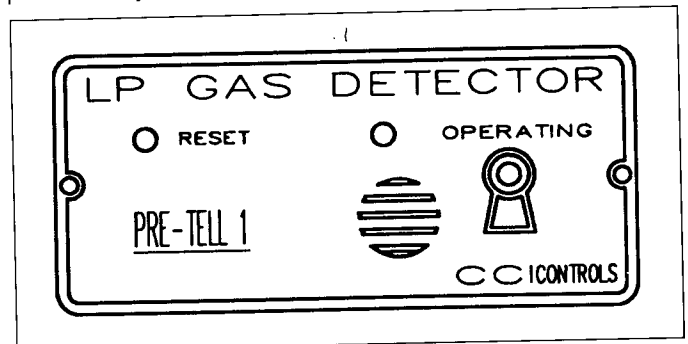

LP GAS LEAK DETECTOR (TYPICAL)

LP GAS REGULATOR FREEZE-UPS

LP gas regulator freeze-up is a problem RV owners can prevent if they are aware of its causes. Although every precaution is taken by fuel producers, tank manufacturer's, and LP gas dealers to keep moisture out of the fuel, this problem at times does exist and causes regulator freeze-ups. Suggestions that you may want to follow to help prevent this moisture are:

1. Always keep the main tank valve closed during periods that gas is not in use, especially if the tank is empty.
2. Contact your LP gas dealer about the addition of methyl alcohol to your tank. Your dealer may do this for a minimal charge, and it will help to prevent freeze-up.

FILLING LP GAS BOTTLES

Follow these basic practices to ensure safety.

1. Do not fill your tank beyond the legal liquid level capacity.
 2. Never use a wrench or pliers to close to POL valve or liquid level on your tank. These valves are designed to be closed leak-tight by hand. If wrenches are necessary to stop a leak, the valve should be replaced.
 3. Use a proper wrench to tighten the left-hand thread POL nut on the SERVICE valve. Do not overtighten it or jam it. This is a machined brass fitting that seats securely against a female seat in the POL valve; it requires no pipe joint compound.
 4. Open the POL valve all the way and then close it one quarter turn. This should be done when you are ready to use your tank. This will assist you in determining if the valve is opened or closed.
 5. Make periodic checks for leaks in all tank and line connections. Use a propane gas leak detector solution to make these checks. Vibrations during travel may cause leaks.
 6. Be sure to fasten your tank(s) securely in place.
 7. Transport your tank in the same position as it is used normally. Make sure the valve is closed. Do this whether you remove your tank for transport to a dealer or for a refill. Always secure the tank to keep it from falling or rolling.
 8. Practice safety at all times. LP gas can be dangerous. If you have any questions about the operation of your gas appliances or the LP gas system, contact your local LP gas dealer.
- The following warning label can be found near the LP gas container:
- DO NOT FILL CONTAINER(S) TO MORE THAN 80% OF CAPACITY. Over-filling the LP gas container can result in an uncontrolled gas flow which can cause fire or explosion. A properly filled container will contain approximately 80% of its volume as liquid LP gas. If the tank is over-filled, have the LP gas dealer bleed out the excess. DO NOT smoke,**

strike a match, or ignite a lighter when the LP gas container is being filled. A spark or flame could ignite fumes. Be certain all burner and pilot flames are out and Service Valve is closed when filling your vehicle's LP gas or fuel tanks.

APPLIANCES AND ACCESSORIES

RANGE, RANGE HOOD, OVEN

Your RV has a three burner range; it may have an oven beneath the range or at eye-level, and it may have a gravity range hood with a light, a power range hood with a fan and light, or a range hood with fan only. The range burners and oven are LP gas appliances. Read the range manufacturer's manual carefully for complete details on the operation and care of the range, range hood and oven.



IT IS NOT SAFE TO USE COOKING APPLIANCES FOR COMFORT HEATING. Cooking appliances need fresh air for safe operation. Before operation:

1. Open overhead vent or turn on exhaust fan.
2. Open window.

This warning is to remind you to provide an adequate supply of fresh air for combustion. Unlike homes, the amount of oxygen supply is limited due to the size of the recreational vehicle. Proper ventilation when using the cooking appliance(s) will avoid dangers of asphyxiation. It is especially important that cooking appliances not be used for comfort heating as the danger of asphyxiation is greater when the appliance is used for long periods of time.

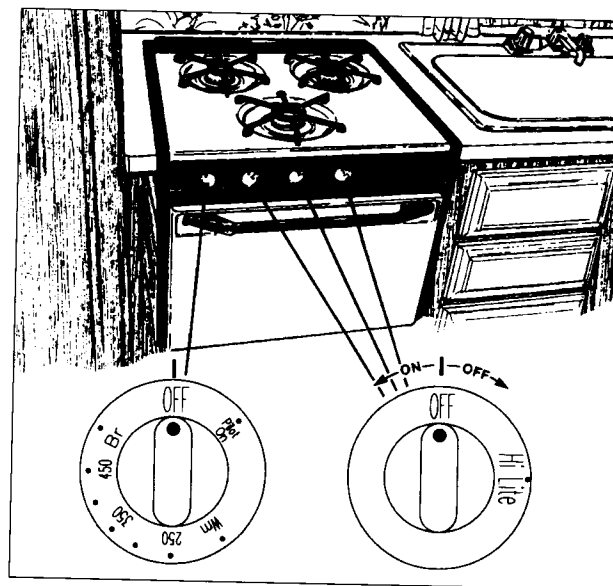

RANGE AND OVEN CONTROLS

LIGHTING THE PILOTS

There are pilot burners on all LP gas ovens. All pilot lights are turned on and off by the oven control knob.

Note: The oven control knob must be in the *PILOTS ON* position for the pilot(s) to be lit. Once lighted, the pilot(s) will continue to burn.

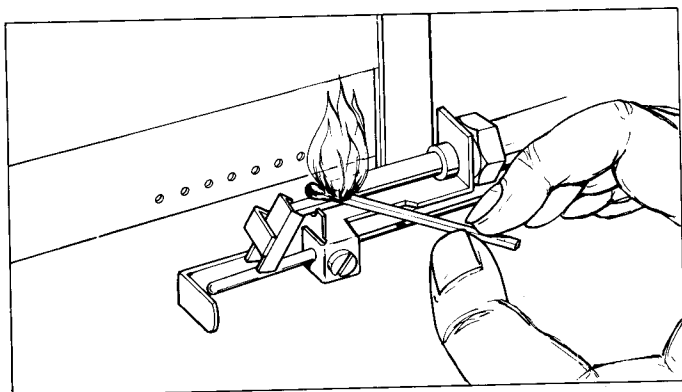

LIGHTING THE OVEN PILOT

To light the oven pilot, be certain the LP gas container Service valve is OPEN, then depress and turn the oven control knob to *PILOTS ON*. Open the oven door and hold a lighted match next to the constant pilot area (it is near the rear of the oven compartment, just below the main oven burner). Relight the pilot if air in the line extinguished the flame. When the pilot remains lit, adjust the oven control knob to the desired temperature.

LIGHTING THE RANGE

Be certain that the LP gas Service valve is OPEN. Light a match and hold it close to the range burner, then turn the burner's control knob to full ON. Air in the line may cause a blowing noise and may extinguish the match. When the line is free of air, the burner will light readily. Adjust the burner flame with the control knob.

BROILER

Your oven is equipped with a broiler. To use it, light the oven and set the control knob to *BROIL*. Place the broiler pan (if equipped) in the area below the oven burner. Do not place meat too close to the flame; grease or fat may ignite. Use foil only as recommended. Never cover the holes in the broiler pan or the air openings in the oven bottom with foil. Always remove the broiler pan as soon as you have finished broiling. If the pan is not removed and the oven is used, the grease may bake onto the surfaces or the grease may ignite.

RANGE HOOD

Your unit will have a gravity or 12-volt range hood. The gravity hood is a vent which allows fumes to escape through a damper. Raise the damper when cooking. The power range hood has a fan and a light, each controlled by a knob on top of the hood. To operate, pull ring on the right side of the filter to release damper. Turn fan ON to draw smoke and cooking fumes out of the unit. To secure the damper, push the ring in. Keep the damper closed when traveling.

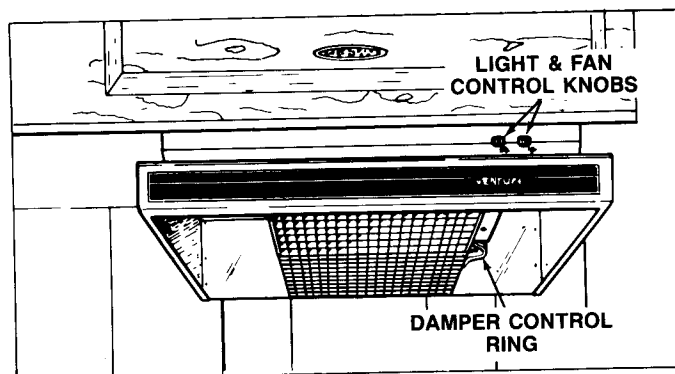

POWER RANGE HOOD

CARE OF RANGE AND OVEN

Allow the range top to cool, then clean it with hot, soapy water. Use a damp cloth to clean chrome surfaces. Grease splatters, which may bake onto the surfaces, should be wiped off before they are time to harden. Use chrome polish to remove stubborn stains.

Clean the oven with commercial cleaner after each trip, or as necessary. DO NOT apply cleaner to aluminum gas tubing, thermostat sensing bulb or electrical components.

CARE OF RANGE HOOD

For metal surfaces, use the same procedure as for the range top. For the power hood, clean the plastic light cover by removing and washing it. If the light burns out, replace with a bulb of the same size. To clean the power hood filter, push slot located in center front of screen and pull down. If not greasy, simply tap the filter to shake out the dirt. If the filter is greasy; run hot, soapy water over it until grease dissolves. Allow the filter to drain and dry, then replace by positioning the flanges and push into place. The gravity hood can be cleaned by gently rubbing a soapy cloth over the screen.

WATER HEATER

Your water heater is an LP gas appliance capable of heating 6 gallons of water to a preset temperature. The water heater is a match light ignition or an electronic ignition appliance. When the system is connected to city water, fill the water heater by opening a hot water faucet. When filling the fresh water tank, turn the water pump ON and open a hot water faucet. In either case, when water flows steadily, turn the faucet OFF.

Before attempting to ignite any of the water heater models, be certain to OPEN the LP gas bottle Service valve.

LIGHTING PILOT

Turn the gas knob to OFF. Always wait 5 minutes to allow LP gas, which may have collected in the burner compartment, to dissipate. Your water heater will be equipped with a Robertshaw "UNITROL" thermostat (Figure 13, page 41) or an ITT General Control Thermostat (Figure 14, Page 41).

*** CAUTION ***

DO NOT light pilot unless water heater is full of water.

ROBERTSHAW "UNITROL" THERMOSTAT

Turn the gas knob counterclockwise to PILOT. Press and hold the reset button while you apply a lighted match to the pilot burner. Release the reset button after pilot has burned one minute (repeat procedure if pilot goes out). Turn the gas knob to ON.

ITT GENERAL CONTROL THERMOSTAT

Turn and hold the gas knob to the PILOT position as you hold a lighted match to the pilot burner. Release the gas knob after one minute (repeat procedure if pilot goes out). Turn the gas knob to ON.

TEMPERATURE CONTROL

Adjust the Temperature Control lever on either Unitrol or ITT thermostat to the desired temperature as marked on the control.

The main burner will light automatically and burn as needed to maintain the temperature you have selected. It is a good idea to light the water heater the night before you leave and turn it off in the morning. The water will remain hot for some time while you are traveling.

PILOT ADJUSTMENT

Remove the pilot adjustment screw protective cap and turn set screw to adjust the flame so it is 1/2" high.

BURNER ADJUSTMENT

Loosen the set screw which holds the air shutter in place. Slide the main burner air shutter to the right until the flame has a yellow tip. Slowly slide the shutter to the left until the yellow tip disappears. Tighten set screw.

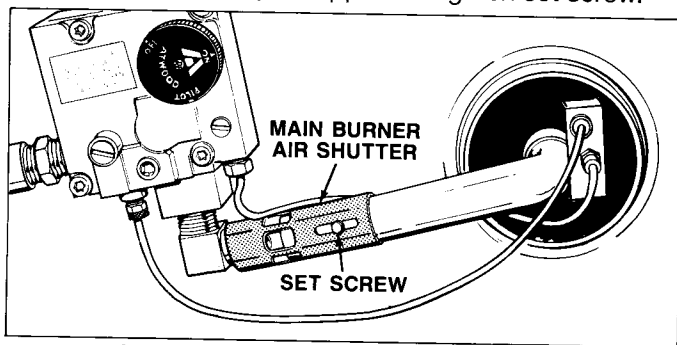

WATER HEATER BURNER ADJUSTMENT

EXTINGUISHING BURNER

Turn the gas knob to OFF.

ELECTRONIC IGNITION

Place the switch in the on position. If the switch light comes on and stays on, place switch in off position and wait 5 minutes. The switch light will only come on in the event of a water heater malfunction or the burner fails to light. After the required delay, place switch to the

on position. It may take more than one attempt to light the burner when using the water heater for the first time or after the LP gas bottle has been refilled. For complete shut down, place switch in off position. The switch will be located in the kitchen area or on the monitor panel.

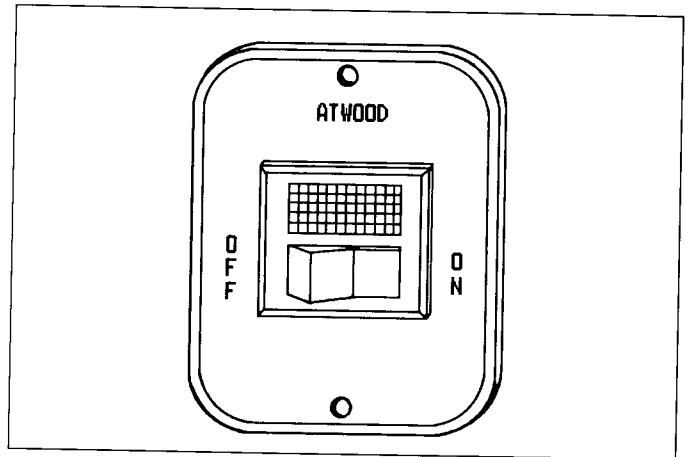

REMOTE WATER HEATER SWITCH

DRAINING

The hot water system has a drain plug or drain cock in the water heater which must be opened or removed to drain the water heater tank. To facilitate drainage, open all hot water faucets. When water ceases to drain, replace plug. Because of the location of the drain plug, about two quarts of water will remain in the bottom of the tank. This can be flushed as described in CARE OF WATER HEATER.

*** CAUTION ***

Hydrogen gas can be produced in a hot water system served by a heater that has not been used for a long period of time (generally two weeks or more). HYDROGEN GAS IS EXTREMELY FLAMMABLE. To reduce the risk of injury under these conditions, it is recommended that the hot water faucet be opened for several minutes at the kitchen sink before using any electrical appliance. If hydrogen is present, there should be an unusual sound such as air escaping through the pipe as the water begins to flow. There should be no smoking or open flame near the faucet at the time it is open. Contact your dealer or the Service Department at the address on the manufacturer's warranty if you are not certain of what action you should take.

CARE OF WATER HEATER

Be certain the exterior compartment is clean and does not contain combustible materials. Never obstruct the relief valve or exhaust vent. Periodically drain and flush the water heater tank.

To flush the tank, connect a hose to the city water fill. Remove the drain plug from the water heater tank. Run water for several minutes to flush tank. Turn water off and reinstall drain plug.

FURNACE

Furnaces are automatic ignition appliances, controlled by a wall thermostat. Heat is delivered through a duct system or directly through the front grille.

Note: Although the furnace's fuel source is LP gas, the power operates on 12-volt DC electricity. The furnace requires 9 volts of 12-volt energy to operate.

*** CAUTION ***

DO NOT use portable fuel-burning heating appliances, including kerosene heaters, wood and charcoal grills and stoves, in your recreational vehicle. Such appliances produce excessive moisture, consume oxygen and may emit dangerous products of combustion.

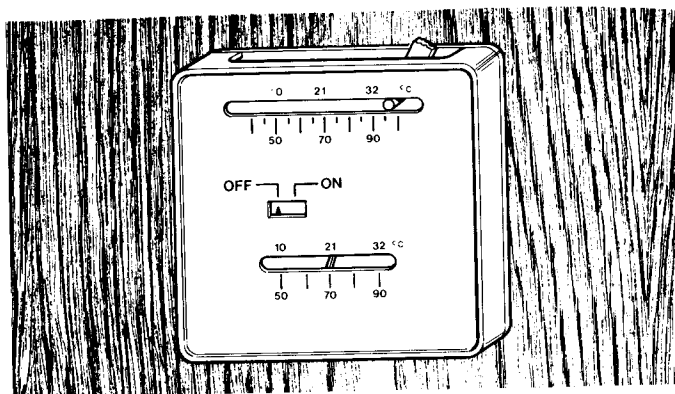

THERMOSTAT

IGNITION

Before lighting a furnace, be sure the LP gas bottle Service valve is OPEN and the thermostat ON/OFF switch is ON.

Automatic Models—Turn manual gas valve to ON. Set thermostat to desired temperature and turn ON/OFF switch to ON. An automatic relay in your furnace provides a time delay. Therefore, when you turn up the thermostat there will be a pause prior to startup of the blower. At blower startup, your furnace air will enter your living quarters at room temperature.

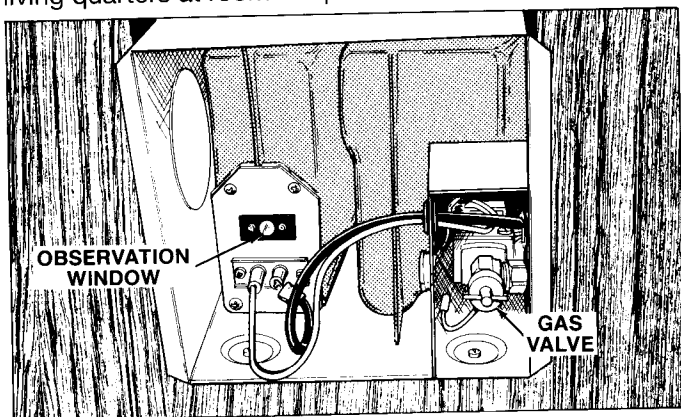

DIRECT VENT FURNACE

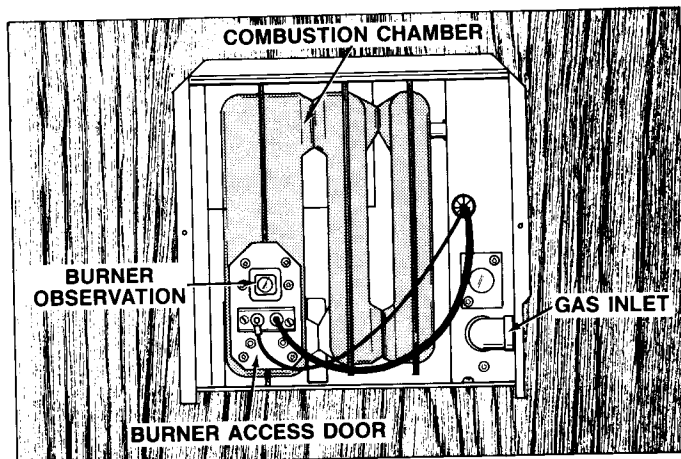

DUCT SYSTEM FURNACE

Your furnace will start warming quickly and continue getting warmer for the next several minutes. If your RV is cold throughout, it may take from one to several hours to heat all interior walls, ceilings, floors and fixtures to a comfortable temperature. Once reached, your furnace will automatically maintain steady warmth.

On initial lighting, the burner may not ignite due to air in the gas lines. If this occurs, set the thermostat back to the lowest setting and wait 30 seconds; then reset thermostat to the desired temperature.

Note: If the furnace does not light after several attempts, while allowing each time for any delay pause, turn the thermostat and the furnace gas control valve OFF and contact your RV dealer or service center. DO NOT attempt to repair or adjust the furnace yourself.

For complete shutdown, turn gas valve to OFF and the thermostat to OFF.

*** CAUTION ***

When changing your unit's electrical source, as from 12-volt to Shoreline or generator, turn the thermostat off. This will preserve the life of your furnace's electronic system. Carefully read the furnace manufacturers manual for other important Do's and Dont's of service and operation.

PREVENTIVE MAINTENANCE

Preventative maintenance should be performed annually by an authorized dealer and should include cleaning of heat exchanger, furnace ducts (Figure 15, Page 42) and blower wheels to remove dust, lint and other foreign materials. The furnace's LP gas system should also be checked.

REFRIGERATOR

Refrigerators are operational on LP gas, or 120 volt A/C. 12 volt D/C power is required for any mode of operation. All come with operational instructions and most have instructions posted near the controls. Ask your dealer to demonstrate the operation of the refrigerator.

ator in your motorhome. The instructions given here are for your convenience; in case of a difference, use the instructions furnished with your refrigerator.

The refrigerator operates on the gravity flow of chemicals, so it must be level. If you must stop on an uneven site for more than 30 minutes, turn the refrigerator OFF. Use a level in the freezer compartment to check levelness.

Before starting on a trip, use the Shoreline connection or LP gas to cool the refrigerator the night before departing. Keep items to be stored in the RV refrigerator in your home refrigerator or freezer until you are ready to leave. This will reduce the cooling load on your refrigerator and help keep perishable foods fresh longer. Always store food in sealable containers or suitable wrapping. When traveling, switch to LP gas operation. Use door lock during travel.

Note: Some states and municipalities do not allow operation of LP gas systems which the vehicle is in motion. If you have a question in this regard, check with local law enforcement authorities.

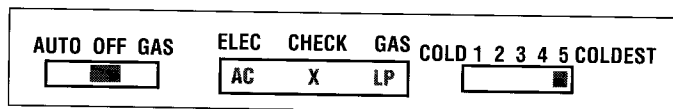

NORCOLD REFRIGERATOR CONTROLS

The Norcold refrigerator has switches near the top of the unit to select the type of operation you desire. A colored light will come on to indicate that the type of energy you have selected is operating properly: blue for LP gas, and green for 120 volt electricity. On all models, turn the thermostat to Max Cold position when starting, then later adjust the thermostat to the desired temperature. When using LP gas, if ignition does not occur, a Check (CK) Light will come on. To restart when Check Light is ON, depress the switch to the "OFF" position and wait 10 seconds. Then depress switch again to the LP gas position. If you have just refilled your LP gas bottles, this operation may have to be repeated four times. Do not continue to reset the LP gas switch if the Check Light continues to come on after four attempts. If the Check Light comes on, turn the switch to "OFF" and check your LP gas supply. If you have an ample LP gas supply, consult your Coachmen dealer.

MODE SELECTOR

Auto: The refrigerator will operate on 120 volts AC so long as AC power is available to the refrigerator. If AC power is lost or disconnected, the selector will automatically switch to gas operation. As soon as AC power is restored, the selector automatically switches back to AC operation (the user does not have to manually switch the refrigerator back to AC). When the operation is automatically switched to gas, the burner will ignite and continue to operate the refrigerator at the same thermostat setting as that set for AC power.

Gas: This selection allows the refrigerator to operate on LP gas only. It will not automatically switch modes

regardless of whether AC power is connected. If the flame is lost (LP bottle empty, etc.), the operation locks out and must be manually reset.

HIGH HUMIDITY/STORAGE SWITCH

Turning this switch to HIGH HUMIDITY will keep the surface between the door openings dry during high humidity conditions. The switch should be left in the NORMAL OPERATION position unless condensate is observed in this area. Both NORMAL and HIGH HUMIDITY positions allow the cabinet light to activate when the lower door is opened.

When your RV is being stored for the winter, this switch should be placed in the STORAGE (light off) position. This shuts off all DC power to the light and humidity heater and allows the refrigerator door to be left open for airing without chance of battery drain during storage.

Important: Refer to your Norcold operation instructions for additional safety precautions, operating information and care of your appliance.

ICE BOX

Place ice in the top tray. Make sure the hose, located near the back of the tray, is not bent or clogged. Water drains through this hose and onto the ground as the ice melts.

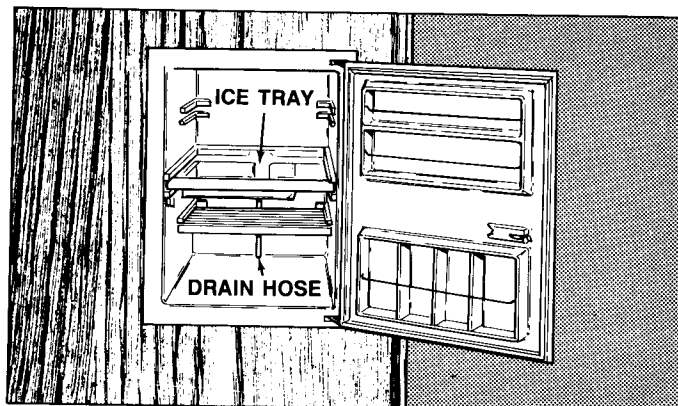

ICE BOX

CARE OF REFRIGERATOR AND ICE BOX

Remove food and ice after each trip. Clean the interior of the refrigerator with a lukewarm, mild soda solution. The evaporator, ice trays and shelves must, however, be cleaned with warm water only. Wipe dry with a soft, dry cloth. Never use strong chemicals or abrasives to clean the refrigerator; they can do harm to the plastic and aluminum surfaces. If the refrigerator is not in use for a period of time, turn all power off, empty and clean the interior and leave the door slightly ajar.

To defrost refrigerator freezer, remove food and ice. Turn the thermostat OFF. To speed up the defrosting process, fill the ice trays with hot water. When all frost is melted, empty the drip tray and dry the interior of the refrigerator with a clean cloth. Replace the drip tray and ice trays, replace all food stuffs and set the thermostat

at MAX for a few hours. Later, reset the thermostat knob to its normal position.

ROOF AIR CONDITIONER

If you did not order the optional roof air conditioner at the time of purchase, your unit may be wired so that one can be installed later; ask your dealer. The roof air conditioner will operate only on 120-volt electricity.

More than one type of roof air conditioner is installed at the factory. Consult your dealer and your roof air conditioner manufacturer's manual for specific instructions for the one installed in your motorhome.

Before starting any model of roof air conditioner, close all doors and windows. The controls for the air conditioner are on a panel on the portion of the appliance that is attached to the ceiling inside your unit. You can select cooling or fan only.

AIR CIRCULATING ONLY/COOLING

Turn the Selector switch to COOLING, then rotate the thermostat to the position that is most comfortable to you and adjust the directional louvers to the desired direction of air flow. The compressor will cycle on and off, automatically maintaining the temperature you've set.

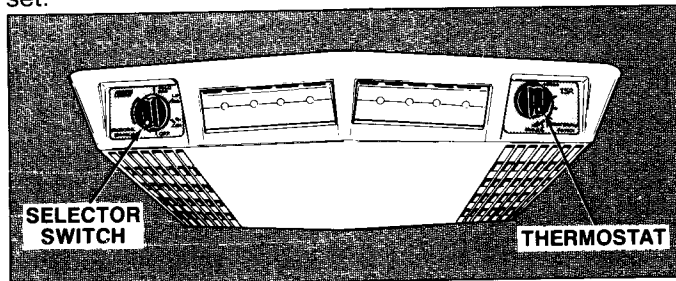

ROOF AIR CONDITIONER CONTROLS

TV ANTENNA

Television reception can be better in many areas with an optional RV antenna. The TV antenna hookup includes an amplifying system, a coaxial connection for the antenna cable to your TV set, and a TV crank for inside control. The cable connection, amplifying system switch and power ON indicator light are on a wall plate. Several types are used so refer to the manufacturer's instructions for details.

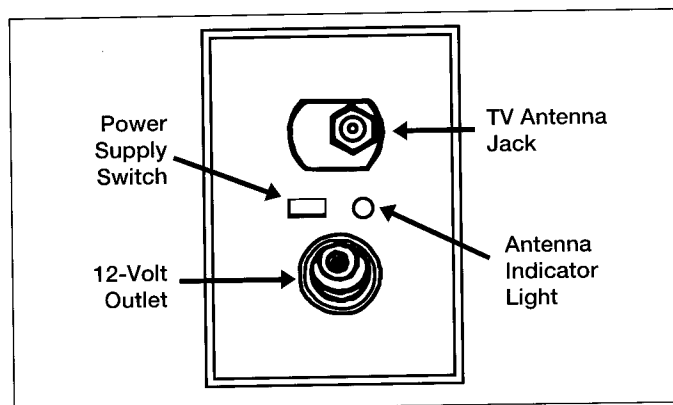

TV WALL PLATE

To raise the antenna, turn the antenna control handle in the up direction until some resistance is felt. Pull down the rotating knob to disengage it from the ceiling plate and turn it until you find the best sound and signal.

Always lower the antenna before moving your recreational vehicle. Pull down and turn the rotating portion so that the pointer lines up with the ceiling plate pointer. Turn control handle in down direction until some resistance is felt. Turn off the power switch on the wall plate.

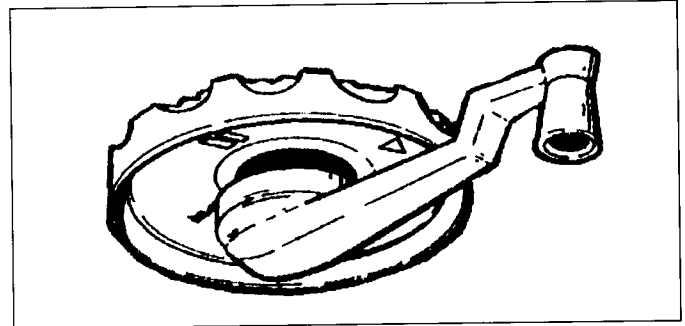

TV ANTENNA CONTROL

Most wall plates also have a 12-volt receptacle for TV sets designed to run on 12-volt DC power. This receptacle should not be used for high current devices such as 12-volt hair dryers, as the maximum amp draw should not exceed 7.5 amps.

Note: Even though your 12-volt radio and/or TV antenna will operate on the 12-volt current that is supplied through the power converter, spikes and surges in the current are possible and will result in poor reception. It is recommended, therefore, that these items be used only in conjunction with a properly installed RV battery.

MONITOR PANEL

Your RV is equipped with a monitor panel located on the range hood that allows you to check the condition of your RV battery and the volume of fresh, waste and gray water in your unit's holding tanks. It also will monitor LP Gas in tank and includes switches for the water pump and generator. Your dealer will be happy to explain its operation.

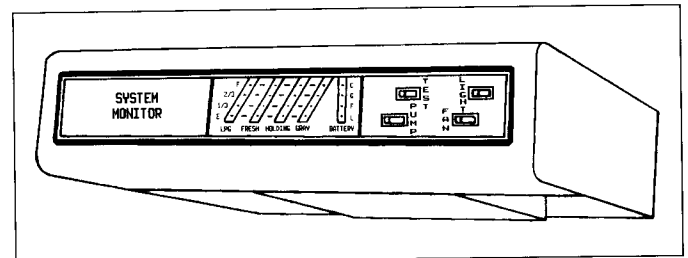

MONITOR PANEL

BATTERY CONDITION LEVELS

The battery condition will fall into one of the following levels:

- C** Converter, more than 14.5 volts (unfiltered circuit or dead cells in battery).
- G** Good, 12.6–14.49 volts.
- F** Fair, 12.0–12.5 volts.
- L** Low, 5–11.9 volts.

STORAGE

You should follow these procedures if you will not be using your unit for an extended period.

The unit should be placed on suitable, sturdy blocking, with jacks down, on a firm, level surface. **DO NOT** store or use unit supported by jacks only.

LP GAS

Close the LP gas container's Service valve. Extinguish all pilots and close all appliance LP gas valves (oven/range, water heater, refrigerator, furnace). Light a range burner to consume any gas remaining in the lines. When the flame burns out, turn the range burner off.

WATER HEATER

Drain the water heater. To drain, see Water Heater Draining in the APPLIANCE section of this manual.

WATER TANK

To drain see water tank, switch the water pump on and open all faucets. Remove the water tank's exterior drain cap, if so equipped, or open the tank's drain valve. Open all hot and cold water line drain valves. When the tank is empty, close all faucets and drain valves, and replace the drain cap.

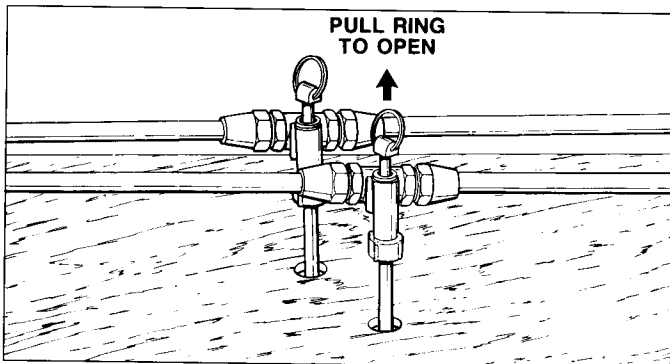

WATER LINE DRAIN VALVES

WATER PUMP

When the water tank and water lines have been drained, remove the outlet hose from the pump. Turn the pump on, allowing it to pump out any remaining water, usually about a cupful. Use a towel or cloth to catch this water. Reattach the outlet hose.

ELECTRICAL SYSTEM

Turn off all circuit breakers at the Power Center.

GENERAL

Close and secure all doors and windows. Open a roof vent or window slightly to allow circulation, but not so far that rain or snow can enter.

WINTERIZATION

Make special preparations for storing your unit in cold winter climates. All systems and components should be inspected and, if necessary, repaired prior to storage.

Note: If you will be using your RV during cold weather, be certain to keep the fresh water system drained or use an **approved, non-toxic RV antifreeze** to prevent freeze-ups. Have an LP gas supplier add methanol to your LP gas containers. Consult your authorized Coachmen dealer for more information.

REFRIGERATOR

Remove all food from the refrigerator, defrost and wash and dry the inside. Prop the door open so air can circulate.

CABINETS

Check the staple foods in your cupboards and remove any that could freeze and be damaged. Leave cabinet and closet doors open a little to prevent a musty odor or mildew.

HOLDING TANKS

The dump valve shafts should be inspected and lubricated, if necessary. Be certain the dump valves are closed.

FRESH WATER SYSTEM

Drain as described in the STORAGE section of this manual, then pour six gallons of non-toxic RV antifreeze into the gravity water fill. This will allow you to winterize the remainder of the fresh water system. Winterize the fresh water system by briefly opening all water faucets and switching the water pump on. Close the faucets when antifreeze flows out. Switch the pump off. Pour non-toxic antifreeze into both kitchen sinks and the dhower drain, enough to fill P-traps.

* CAUTION *

Do not use automotive antifreeze in the water system. It is poisonous.

WATER HEATER

Drain (see Water Heater Draining in APPLIANCE section). Although about two quarts of water will remain after the heater has been drained, there is ample room

for expansion if it freezes. Add antifreeze to the water heater tank by opening a hot water faucet. When antifreeze appears at the spout, close the faucet.

WATER TANK

Drain by switching the water pump on and opening all faucets. Remove the water tank's exterior drain cap, if so equipped, or open the tank's drain valve. Open all hot and cold wastewater line drain valves. When the tank is empty, close all faucets and drain valves, and replace the drain cap.

WATER PUMP

The water pump should be drained when the water tank and water lines have been drained. Remove the outlet hose from the pump. Turn pump on, allowing it to pump out any remaining water, usually about a cupful. Use a towel or other cloth to catch this water. You can reattach the outlet hose now or later.

TOILET

Flush toilet until antifreeze is present in the bowl. Pour one gallon of fresh-water antifreeze down the toilet to winterize the waste water holding tank. The toilet water supply line should be drained completely and the water supply valve should be left open. On models with the black/white levers, block the white lever in the open position with a wad of paper. When using air pressure to drain the water line, toilet valve should be held in the open position. If water is inadvertently frozen in the toilet, do not flush until the ice is thawed.

LP GAS REGULATOR

Cover to keep moisture out of vent. LP gas system should be prepared as described in STORAGE section. Containers should have anhydrous methanol added by an LP gas supplier.

WINDOWS

Cover with newspaper or cardboard to protect fabrics from fading.

EXTERIOR VENTS

Cover range hood, refrigerator and furnace vents with plastic. Inspect all roof vents and replace, if necessary.

* CAUTION *

Never use appliances with vent covers in place.

EXTERIOR

Clean and wax, lubricate locks and hinges. Check under the RV for any openings which would allow varmints to enter; seal if necessary. Lock securely. Inspect throughout the winter months and remove any snow accumulation from the roof with a long-handled broom or similar tool.

FIRE SAFETY

Prevention is the best form of fire safety. Observe the same precautions in your RV as you do in your home.

Use care with any open flame inside of your unit. Follow the instructions previously listed for the care and maintenance, and operation of the various appliances in your motorhome.

Make certain everyone in your party is familiar with the emergency features of the unit, the location of exits and the location and operation of fire extinguishers. "It is recommended that a fire drill be conducted on a regular basis to ensure this knowledge." A chemical fire extinguisher has been furnished with your unit. Check it regularly to be sure it is ready for emergency use. Immediately replace a fire extinguisher that is discharged or partially discharged. Fire extinguishers are located directly inside the front entrance door on either a cabinet or on the sidewall.

Do not bring or store LP gas containers, gasoline or other flammable liquids inside your RV.

EMERGENCY EXITS

Emergency exits are installed in some models. These will be marked by a label which has one-inch red letters. Handles that must be operated to open emergency exits also will be colored red. Make certain your dealer explains the location and operation of emergency exits to you, and that you inform all members of your party.

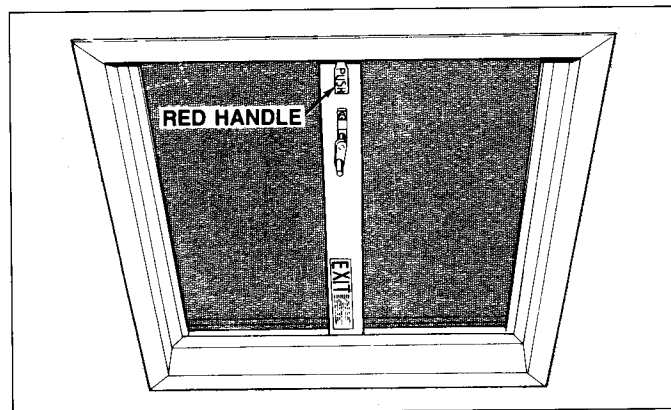

EMERGENCY EXIT

RV MAINTENANCE

GENERAL

Recreational vehicle owners are noted for the pride they take in the appearance of their units. Proper maintenance will do more than keep your unit looking nice. It can help ensure trouble-free operation and maximum efficiency of the various appliance and components. Failure to properly maintain the vehicle or its components may also constitute a breach of your warranty.

obligations. Negligence, misuse or installation of unauthorized equipment could affect the operation of your unit and may void your warranty. See the various manufacturer's manuals for specific maintenance instructions.

Unless otherwise noted, maintenance functions should be performed at least annually. All maintenance schedules listed are the minimum requirement; heavy use, unusual temperatures or humidity, or other environmental conditions may require more frequent maintenance. At the start of each season, or after a period of storage, thoroughly inspect and test all systems and components to be certain they are functioning properly before you use your RV.

CANVAS

To condition the canvas prior to your first trip, set up the camper and spray with water. Allow the canvas to dry and then spray again. This will expand the thread inside the stitch holes. Always ventilate and dry the canvas with bows and braces in place, as soon as possible after each exposure to moisture. After every trip, wash dust and dirt, bird and tree droppings, insects and other foreign material from the exterior canvas surfaces. These substances can destroy the canvas' water repellency. Use warm water and a soft bristle brush to remove stubborn stains. Rinse canvas with cool water. Allow the canvas to dry completely before lowering. Mend tears and holes with patching material or cement. Leaks in canvas seams can be repaired by spraying the seam with a quality water repellent, available from your Coachmen dealer.



Use of sprays (hair, insect, deodorant, etc.) near fabric can destroy fabric finish. NEVER allow spray to come in contact with tent fabric.

Airing of the unit is essential before you occupy it. See details under the AIR QUALITY and CONDENSATION sections of this manual.

Awning Supports and bright metal parts should be cleaned and coated with silicone annually.

Body should be washed to remove dirt, dust, road tar, bird and tree droppings, insects, and other foreign material from exterior surfaces. Use a mild soap in lukewarm water. Apply an automotive-type wax at least once a year.

Counter and Table Tops should be cleaned periodically with a mild detergent and polished with a product such as Pride or Pledge.

Electrical System should be inspected and tested prior to each trip. Check the Shoreline for damage. Test the 120-volt system for proper polarity and voltage. You may want to purchase a ground monitor and a line voltage tester to perform these checks.

Fabrics need regular and continuing care. To keep

them at their best, vacuum and brush away loose dirt before it becomes embedded and more difficult to remove. Clean spills and stains while fresh. VELVET fabrics should be cleaned with extreme care. Spills on velvet generally will bead-up. Blot them up quickly and gently so as not to force the stain deep into the fabric. If a stain remains, spot-clean using one of the methods described below. Wipe the stain in the direction of the pile to prevent distortion. When the fabric is dry, gently brush with a soft brush. Many velvet fabrics cannot be cleaned with water-based cleaning agents.

Draperies, Curtains, Bedspreads should be dry-cleaned only.

Cushions, Chairs may be labeled with the voluntary industry cleanability code. Because dyes or backings on some upholstery fabrics will be affected by water or solvents, the cleanability code will indicate the cleaning method that is safe for your fabric. If the furniture is not coded, test the fabric for discoloration on an inconspicuous part of the furniture before spot-cleaning. The code is symbolized by the following letter:

W

Use only water-based cleaning agents or foam. Mix two tablespoons ammonia or detergent, such as Ajax liquid, with a quart of water. Wipe the stain gently with a clean cloth dampened with the solution. Continue wiping, turning the cloth so that you are always using a clean portion, until the stain is removed. Be careful not to wet the fabric too much. Always wipe from the outer edge of the stain toward the center.

S

Use only mild, pure, water-free dry-cleaning solvents, such as Energine or Carbona. Dampen a clean cloth with the solvent and follow the same procedure described under W.

WS

Either of the above methods may be used.

X

Clean fabric only by vacuuming or light brushing to remove soil. Do not use liquid cleaning agents of any kind.

TYPES OF STAINS

Water-Based—ketchup, soft drinks, milk, etc. Remove using method W.

Oil-Based—salad dressing, butter, greasy food, etc. Use method S or, for flat-woven fabrics, not velvet, apply Texize K2R Spot Remover according to directions.

Combination—ice cream, gravy, etc. are both watery and oily. Remove these types of stains using the S method and follow with the W method.

Mud—lift away what you can easily remove without forcing the mud into the fabric. Allow the remaining mud to dry completely, then vacuum. If the stain remains, clean with method W.

When overall cleaning is necessary, professional cleaners are recommended. However, if you wish to do it yourself, follow these suggestions:

1. Vacuum thoroughly
2. Test fabric for discoloration on an inconspicuous place using a foam cleaner such as Fibre Fresh Concentrate or Glamorene.
3. If no discoloration appears, use cleaner on entire item. *Note:* Many velvet fabrics cannot be cleaned with water-based cleaning agents.
4. After cleaning, you may wish to apply Scotch-guard fabric protector to such areas as furniture arms, backs and cushions.

Note: *The above information is provided only as a service and should not be interpreted as a warranty. The list of cleaning agents does not constitute an endorsement of products; other similar products may be equally effective.*

Floor Coverings should be cleaned as necessary. Vacuum carpeting. Avoid using heavy moisture; it could enter and damage your floor.

Hinges should be inspected and lubricated with light household oil periodically.

Jacks (manually operated) should be inspected prior to each trip and lubricated every 90 days. Hydraulic jacks also should be inspected prior to each trip, but lubrication is required annually. See the instructions provided with the jack installed on your unit for specific details. Periodically apply a small amount of WD-40 or similar lubricant at friction points of stabilizing jacks.

Locks and Latches should be inspected and lightly lubricated with graphite periodically.

LP Gas system should be inspected and adjusted as outlined in LP GAS section of this manual. Be certain mounting supports for tanks are secure. Before using, be sure all LP gas orifices and vents are clean.

LP Gas Line Check should be performed frequently. Always check the gas line connection after each refill and inspect the connections regularly, at least every 30 days or 5,000 miles of travel. To check, turn off all burners and pilot lights. Open all doors and windows. Open the LP gas tank Service valve and use an approved LP leak detector solution to test all line connections. Bubbles indicate a leak. Do not use products that contain ammonia or chlorine. Tighten the connection with two open end wrenches until bubbles stop. If leak persists, contact your dealer.

Pigtail Contacts should be inspected and coated with WD-40 every 90 days.

Roof, Body, Underbelly should be inspected for damage, rust or corrosion every 90 days and repaired as necessary. You may wish to undercoat the metal underbelly.

Rubber Roof

1. For normal cleaning, standard household products may be used such as 409, Fantastic, or a good detergent soap. Be sure to use lots of water and keep sidewalls wet to eliminate possible streaking.
2. For stubborn stains, the use of an abrasive

cleaner or scouring powder with a 3M pad (medium) should do the job. Again, be sure to use an ample supply of water.

3. For stubborn stains that resist normal cleaning, use unleaded gasoline (**Caution: Flammable**), followed by washing with soap and lots of water.

If an accident happens and you damage the roof, here is a temporary fix: Clean the affected area with unleaded gasoline (**Caution: flammable**) and let dry. Cover the area by overlapping layers of duct tape over the troubled area, until a permanent repair can be made by your Coachmen dealer.

Seams or Joints should be sealed around the roof, entrance doors, windows, roof and wall vents, access doors, storage compartments, roof edges, luggage racks, ladders, air conditioners, TV antenna, rails and moldings at least once each year with a similar high-quality sealant. Inspect all seams and joints at least twice a year and reseal as necessary. Some sealants cannot be applied over other types; when preparing areas to be resealed, scrape off old sealant. Clean metal areas with a vinegar and warm water solution. Clean fiberglass areas with mineral spirits before applying new sealant.

Shades, Blinds and Valances should be vacuumed or wiped with a damp cloth.

Sinks in the unit's kitchen and bathroom should be cleaned with a cleaner that is non-abrasive. Stainless steel cleaner may be purchased at most grocery stores. ABS cleaner may be purchased from your authorized dealer.

Step(s) should be inspected annually. Remove rust; paint steps and lubricate all moving parts.

TV Antenna exterior moving parts should be lubricated periodically.

Vents should be inspected and cleaned annually; lightly oil all moving parts. Inspect vents periodically for bird nests.

Vinyl-Coated ceiling and wall panels should be cleaned with a mild soap and damp sponge as needed.

Water Heater control compartment should be kept clean and free of combustible material and flammable liquids. The vent and combustible air grille should be clear of any obstructions. Manually operate the pressure temperature relief valve at least once a year. Operate only when storage water in tank is cool. Periodically compare main and pilot burner flame with illustrations in the manufacturer's operation instruction manual. Do not tamper with the pilot orifice to increase the pilot flame size; this can cause high water temperature and failure of gas control.

Wood Cabinetry should be protected and cleaned several times a year using any good non-silicone wood polish. Careful control of temperature and humidity will help reduce expansion and shrinkage of doors and door panels. If shrinkage occurs and unfinished parts of the door panels are exposed, cover the exposed areas with matching touchup stain available from your dealer.

Additional or Optional Equipment Weighing over 20 lbs. When Installed

7100 BTU Roof Air Conditioner	82 lbs.	Hide-A-Bed	56 lbs.
16000 BTU Furnace	18 lbs.	3-Burner Range	18 lbs.
2400 BTU Furnace	48 lbs.	35 lb. Ice Box w/Ice	47 lbs.
Water Heater	69 lbs.	75 lb. Ice Box w/Ice	96 lbs.
Marine Toilet, Holding Tank, Lavatory	60 lbs.	1.9 cu.-ft. Refrigerator	33 lbs.
2nd LP Gas Bottle w/Gas	38 lbs.	4 cu.-ft. Refrigerator	88 lbs.
Luggage Rack and Ladder	7 lbs.	6 cu.-ft. Refrigerator	100 lbs.

GENERAL DRIVING CHECKS

For your safety, make certain that the following items have been checked and rechecked before you take your RV on the road. Make certain that all items inside of your RV are secured (e.g., lawn chairs, pots and pans, TV, etc.). As you travel, these items, if not secured, may become damaged or may damage the interior of your RV.

Jacks—The jacks must be raised and secured in their proper place.

Lights—The following lights should be tested on both the RV and the pickup truck: brake lights, warning lights, flashers, clearance lights, taillights and truck headlights.

Pigtail—The pigtail should be connected properly to the truck's electrical harness.

Rearview Mirrors—Adjust the rearview mirrors so that the driver can see the right and left sides of the unit.

OTHER DRIVING CHECKS

Whether you are departing from your home, rest area or campsite, you should check the following parts of your unit before you take off.

Tires—Before each trip, check your tires for uneven wear, road damage, foreign objects or excessive peeling or bulging. Each morning, inspect the condition and pressure. Heat generated by surface friction will increase the tire's air pressure approximately six to nine psi; therefore, do not bleed air out of a hot tire. Inflate the tire to the recommended pressure (indicated either on the tire or in the manufacturer's instruction booklet).

Note: Proper tire inflation is extremely important.

A tire should be replaced when:

1. It is worn to 1/16-inch depth in two or more adjacent grooves.

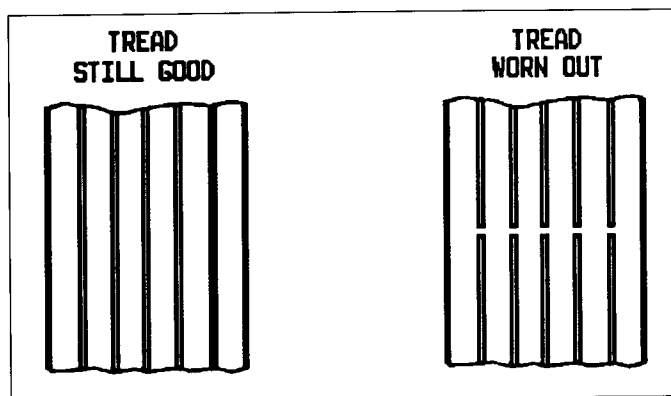

TREAD WEAR INDICATOR

2. It is worn to the level of the tread indicators that are molded into the bottom of the tread grooves, or

3. The indicators appear in two or more adjacent grooves at three locations around the tire.

On new tire purchases, be certain that the new tire is the same size as the old tire and that the new tire has the same ply rating and load range as the old one. DO NOT mix radial-ply tires with bias or bias-belted tires.

Power Cord—The 120-volt shoreline power cord must be unplugged from the external source and placed into its compartment. The cord hatch must be secured before you travel.

Water Fill Hose(s)—All hoses must be disconnected and all hose caps must be secured before you travel.

Sewage Termination Valves—These valves must be closed and locked before you travel. The sewer hose must be removed from the termination valve outlet and stored in the appropriate compartment. Termination caps must be securely fastened to the termination valve outlet(s).

Door Step—The door step must be returned to its travel position before the unit is safe for traveling. To do this, lift the front edge of the step and push it under the unit.

Windows and Vents—All windows and vents should be closed completely or adjusted as desired before you travel.

TV Antenna—The TV antenna must be cranked down to its traveling position.

LP Gas Bottles—LP gas bottles and connections should be secured.

Note: Some states prohibit vehicles equipped with LP gas bottles from using tunnels. A few other states prohibit traveling with the Service Valve open and the pilots lit. Check the regulations of the state through which you intend to travel.

Awning—Make sure the optional awning is raised and secured for travel, per the manufacturer's suggestions.

Automotive System—Be sure to check your pickup truck as outlined in the truck manufacturer's owners' manual.

Interior Doors and Drawers—Close and secure all interior doors and drawers in your unit. Store or secure all loose items.

Exterior Access Doors—Exterior access doors for storage and equipment should be closed and locked.

Refrigerator Door—Secure the refrigerator door with the travel latch, if equipped.

Appendix B Travel Preparation Checklist

CLOTHING

- Underwear
- Socks
- Shoes, sandals, boots
- Shirts
- Blouses
- Trousers
- Slacks
- Dresses
- Shorts
- Sweaters
- Jackets
- Coats
- Rainwear
- Swim wear
- Pajamas

TOOL CHEST

- Screwdrivers
- Pliers
- Hammers
- Tire pressure gauge
- Small level
- Electrical tape
- Masking tape
- Wrenches
- Allen wrench
- Furnace duct tape

CAMPSITE COMFORT

- Dishwashing soap
- Dishcloths
- Dishtowels
- Garbage/trash bags
- Mop
- Broom
- Vacuum cleaner
- Dust pan
- Paper towels
- Foil or plastic wrap
- Throw rug

SAFETY

- First-aid kit
- Flares
- Reflectors
- Tow rope and/or chain

ADDITIONAL TOOLS

- Hatchet
- Shovel
- Saw
- 12-volt portable tire pump

SLEEPING GEAR

- Sheets
- Pillow cases
- Mattress pads
- Blankets
- Pillows
- Sleeping bags

PERSONAL COMFORT

- Towels
- Washcloths
- Toilet paper
- Soap
- Toothbrush
- Toothpaste
- Personal toiletries
- Scissors
- Sewing kit
- Ash trays

MEAL PREPARATION

- Bottle opener
- Can opener
- Matches
- Pots, pans, skillets
- Plates
- Glasses and cups
- Silverware
- Hot pads
- Knives, spatula, etc.
- Baking pans
- Coffee maker
- Toaster
- Plastic containers

ENTERTAINMENT

- Books/magazines
- Binoculars/telescope
- Camera, film, flash
- Tape player/tapes
- Toys/games
- Playing cards
- Television
- Radio

MISC. EQUIPMENT

- Bucket
- Fuses
- Fresh water hose
- Y-type water hose fitting
- Flashlight
- 20-ft. 3-prong power cord
- 3-prong adapter with grounding wire
- Wheel chocks, leveling ramp, blocks or jack stands
- Coat hangers
- Folding lawn chairs

Appendix C Troubleshooting Guide

NOTE: Use the manufacturer's owners' manuals for all appliance trouble shooting.

FURNACE DOES NOT LIGHT

- Check the LP gas supply
- If the furnace does not light after several attempts, do the following:
 1. Turn the thermostat and the furnace gas control valve OFF.
 2. Contact your RV dealer or service center. DO NOT attempt to repair or adjust the furnace yourself.

WATER PUMP FAILURE OR MALFUNCTION

If the pump fails to start when the switch is ON, check the fuse located in the converter. If the pump continues to operate whether the faucets are opened or closed, check the water tank. It might be empty or there might be a leak in the system. If water pump goes on and off, check all fittings for tightness and all lines for leaks.

NO POWER TO UNIT

- Check Shoreline. Make sure you have power to the Shoreline.
- Check the converter; the breaker switches might be off or tripped.

CONVERTER MAKES CLICKING NOISE

- Check circuit for overload.
- Check for reversed polarity at battery.
- Check for reversed AC polarity.

UNIT HAS ELECTRICALLY CHARGED (HOT) CHASSIS

- Disconnect unit from electrical supply.
- Have unit inspected and repaired, if necessary, by a qualified service facility.

Note: Determine if Shoreline supply has proper polarity.

LIGHTS FLICKERING

Check to see if the following could be causing the problem: loose fuse holders, broken fuse, broken connection or wire, bad ground.

LIGHTS DIM OR HALF BRIGHT

Check battery condition. Possible converter malfunction. Possible low voltage from Shoreline.

SMELL GAS

1. Extinguish any open flames, pilot lights and all smoking materials.
2. Do not touch electrical switches.
3. Shut off the gas supply at the tank valve(s) or gas supply connection.
4. Open doors and other ventilating openings.
5. Leave the area until odor clears.
6. Have the gas system checked and leakage source corrected before using again.

WASTE TANK WILL NOT DRAIN

Check for build up in tank at stool. Make sure stool holds water.

REFRIGERATOR WILL NOT COOL

Make sure unit is level. Check that lower and upper refrigerator vents are clear. If on gas, check gas supply.

TV ANTENNA HAS POOR RECEPTION

- Check connections at TV and wall plate.
- Make sure cable is in good condition at TV and antenna (not cut or nicked)
- Check antenna to ensure that it is pointed in the direction of the "sending" station.
- Check TV on another system known to work.

NO RUNNING LIGHTS

- Check plug at unit and tow vehicle
- Check fuse in tow vehicle
- Check bulbs.

TERMINATION VALVE LEAKS

- Check blade inside valve to see that it is clear.
- Check gasket at termination cap.

Maintenance Schedule*

ITEM	Every Trip	Every 30 days or 1,000 miles	Every 60 days	Every 90 days or 2,500 miles	Every 6 months or 5,000 miles	Annually or 10,000 mile	REFERENCE
Airing	•						Air Quality, Condensation, Maintenance, this manual
Appliances	•						• Appliances, this manual; Appliance Manufacturer's instructions
Awning Rails							• Maintenance, this manual
Body					•		Maintenance, this manual
Counter, Table Tops	•						Maintenance, this manual
Doors				•			Maintenance, this manual
Electrical System	•						Maintenance, this manual
Fabrics						•	Care of Fabrics, this manual
Floor Coverings	•						Maintenance, this manual
Hinges						•	Maintenance, this manual
Jacks						•	Maintenance, this manual; Jack Manufacturer's manual
Locks & Latches						•	Maintenance, this manual; Lock/Latch Manufacturer's manual
LP Gas	•	•					LP Gas; this manual; Appliance Manufacturer's instructions
Pigtail Contacts				•			Maintenance, this manual; Pigtail Manufacturer's instructions
Roof, Body, Underbelly				•			Maintenance, this manual
Seams (Seal)						•	Maintenance, this manual
Shades, Valances	•						Maintenance, this manual
Steps	•					•	Maintenance, this manual; Step Manufacturer's instructions
TV Antenna		•					TV Antenna Manufacturer's instructions
Vents						•	Maintenance, this manual; Vent Manufacturer's instructions
Vinyl Ceiling & Wall Panels	•						Maintenance, this manual
Water Heater	•					•	Maintenance, this manual; Water Heater Manufacturer's manual
Windows	•						Maintenance, this manual; Window Manufacturer's instructions
Wood Cabinetry	•		•				Maintenance, this manual

* Maintenance schedules listed are minimum requirements; heavy use, unusual temperatures or humidity, or other environmental conditions may require more frequent maintenance.

Appliance Identification Form

Should your unit or one of the appliances require warranty service, you will have to identify the manufacturer, model designator and serial number. Fill in this form as soon as possible. It will help you meet identification requirement. Depending on your unit, certain items listed below may be offered as either optional and/or standard. Most of this information can be found on the Recreational Vehicle Data Card attached to the inside of one of the kitchen cabinet doors.

EQUIPMENT	MANUFACTURER	MODEL DESIGNATOR	SERIAL NUMBER
Truck Camper	_____	_____	_____
Furnace	_____	_____	_____
Range and Oven	_____	_____	_____
Converter	_____	_____	_____
Refrigerator	_____	_____	_____
Water Pump	_____	_____	_____
Water Heater	_____	_____	_____
Roof Air Conditioner	_____	_____	_____
Intercom	_____	_____	_____
Antenna	_____	_____	_____
Toilet	_____	_____	_____
Door Key	_____	_____	_____
Exterior Storage Compartment	_____	_____	_____

ELECTRICAL SPECIFICATIONS

LIGHT BULBS		TRUCK CAMPER PLUG CODE	DESIGNATOR	COLOR
Interior 12 VDC	#1141	Back Up	S	Blue
Range Hood	25 Watt, 12 VDC	Interior	A	Black
Turn, Tail and Stop	#1157	Right Turn	RT	Brown
Back UP	#1156	Left Turn	LT	Red
License Plate	#67	Ground	GR	White
Clearance, Grab Handle	#67	Running Lights	TM	Green
Patio	#93			

120 VAC light bulb—used in units without 40 Watt converter.

FUSE/CIRCUIT BREAKER SIZES

12 VDC Appliances	15 amp fuse
120 VAC Circuits	15 amp fuse
120 VAC Roof Air Conditioner (U.S.A. Installation)	20 amp breaker
120 VAC Roof Air Conditioner (Canadian Installation)	15 amp breaker
Water Pump Fuse	15 amp slo blo

MISCELLANEOUS

See the advertising brochure for the exterior dimensions, and weight ratings which pertain to your unit.

**WATER HEATER (ROBERTSHAW)
FIGURE 13**

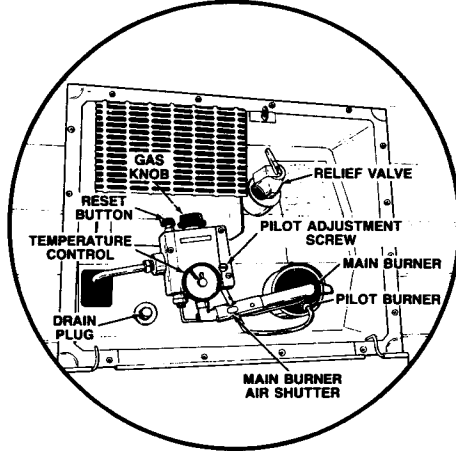

**WATER HEATER (ITT)
FIGURE 14**

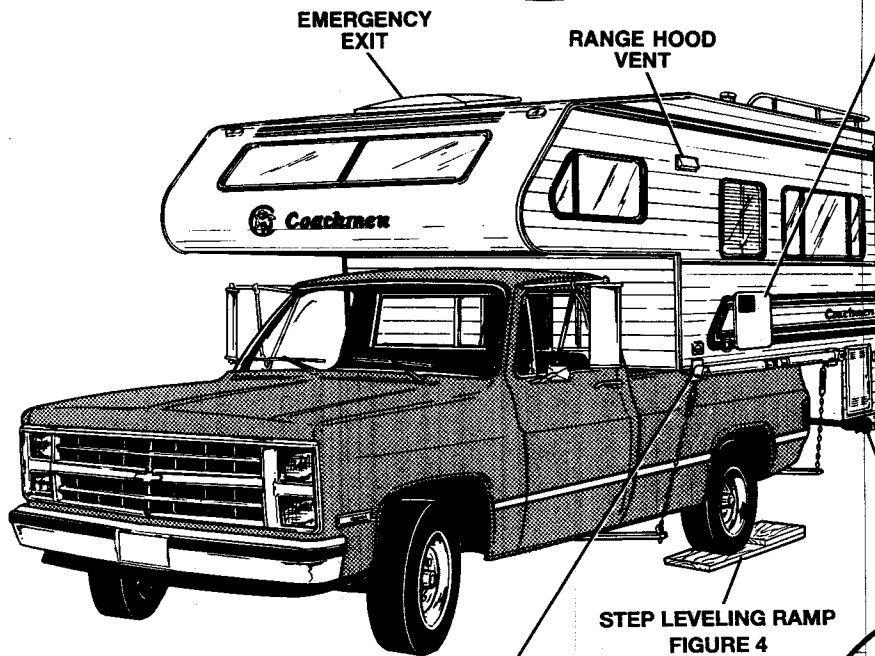
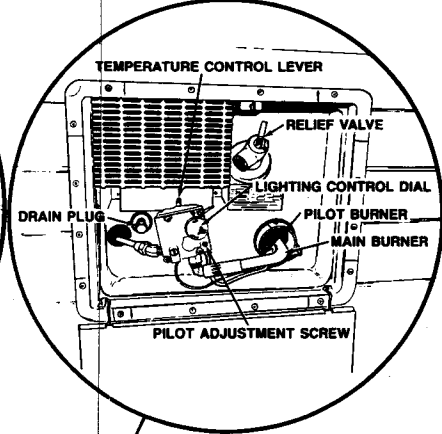

**STEP LEVELING RAMP
FIGURE 4**

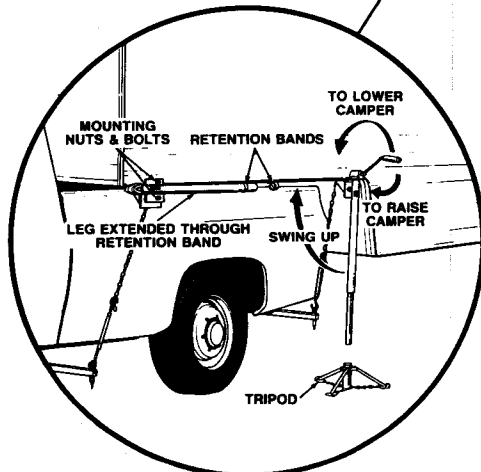

TRIPOD JACK

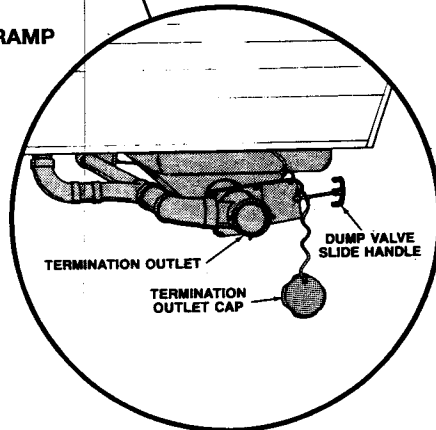

**TERMINATION OUTLET
FIGURE 10**

COACHMEN TRUCK CAMPER

FURNACE INLET/EXHAUST
FIGURE 15

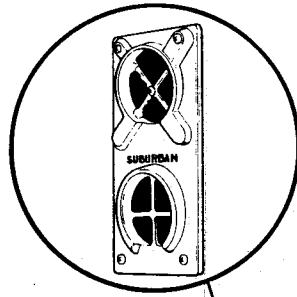

REFRIGERATOR VENT

REFRIGERATOR ACCESS DOOR

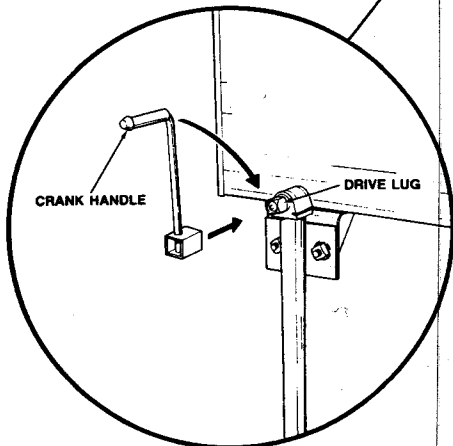
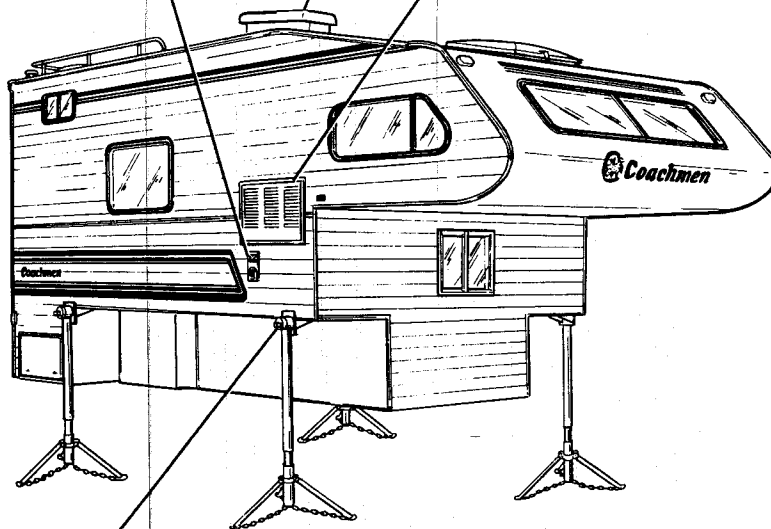

CRANK AND DRIVE LUG

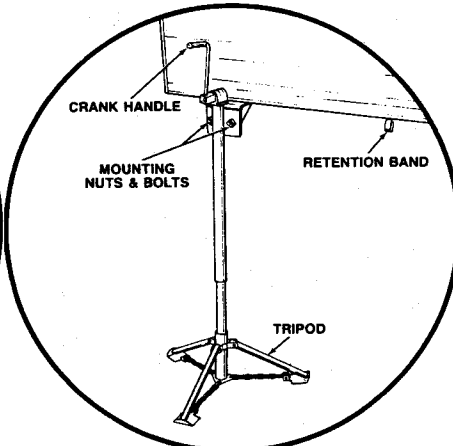

JACK RETENTION BAND

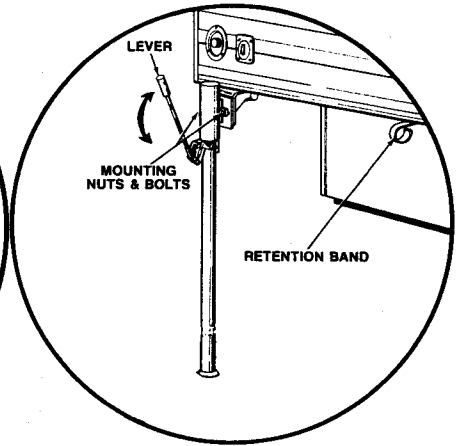

HYDRAULIC JACK (OPTIONAL)

VEHICLES SHOWN ARE FOR ILLUSTRATION PURPOSES ONLY: SOME ITEMS SHOWN ARE NOT AVAILABLE ON CERTAIN MODELS AND MAY BE OPTIONAL ON OTHERS.

CITY WATER FILL
FIGURE 8

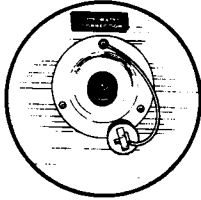

GRAVITY WATER FILL
FIGURE 9

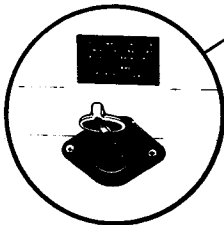
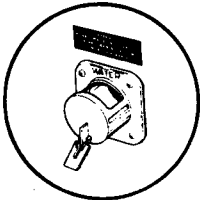

PIGTAIL SOCKET

SHORELINE
FIGURE 7

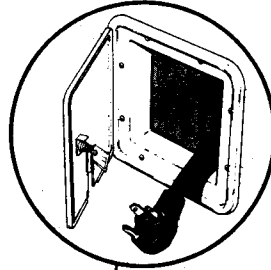

LUGGAGE RACK
(OPTIONAL)

SEWER VENT

LADDER
(OPTIONAL)



20% LIQUID LEVEL
GAUGE

PRESSURE REGULATOR

SERVICE VALVE

RETENTION BAND
BUCKLE

LP GAS BOTTLE
FIGURE 12

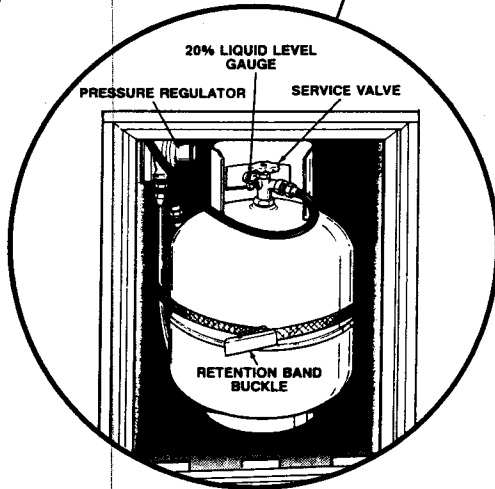

DUMP VALVE
SLIDE HANDLE

TERMINATION OUTLET

TERMINATION
OUTLET CAP

TERMINATION OUTLET
FIGURE 11

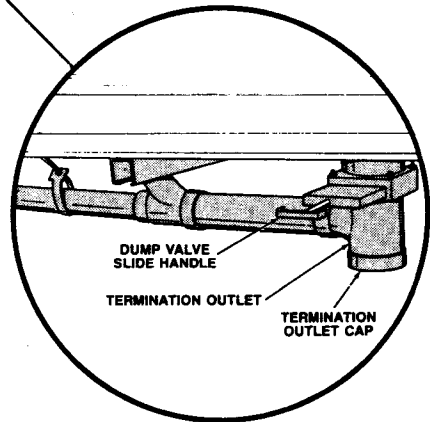

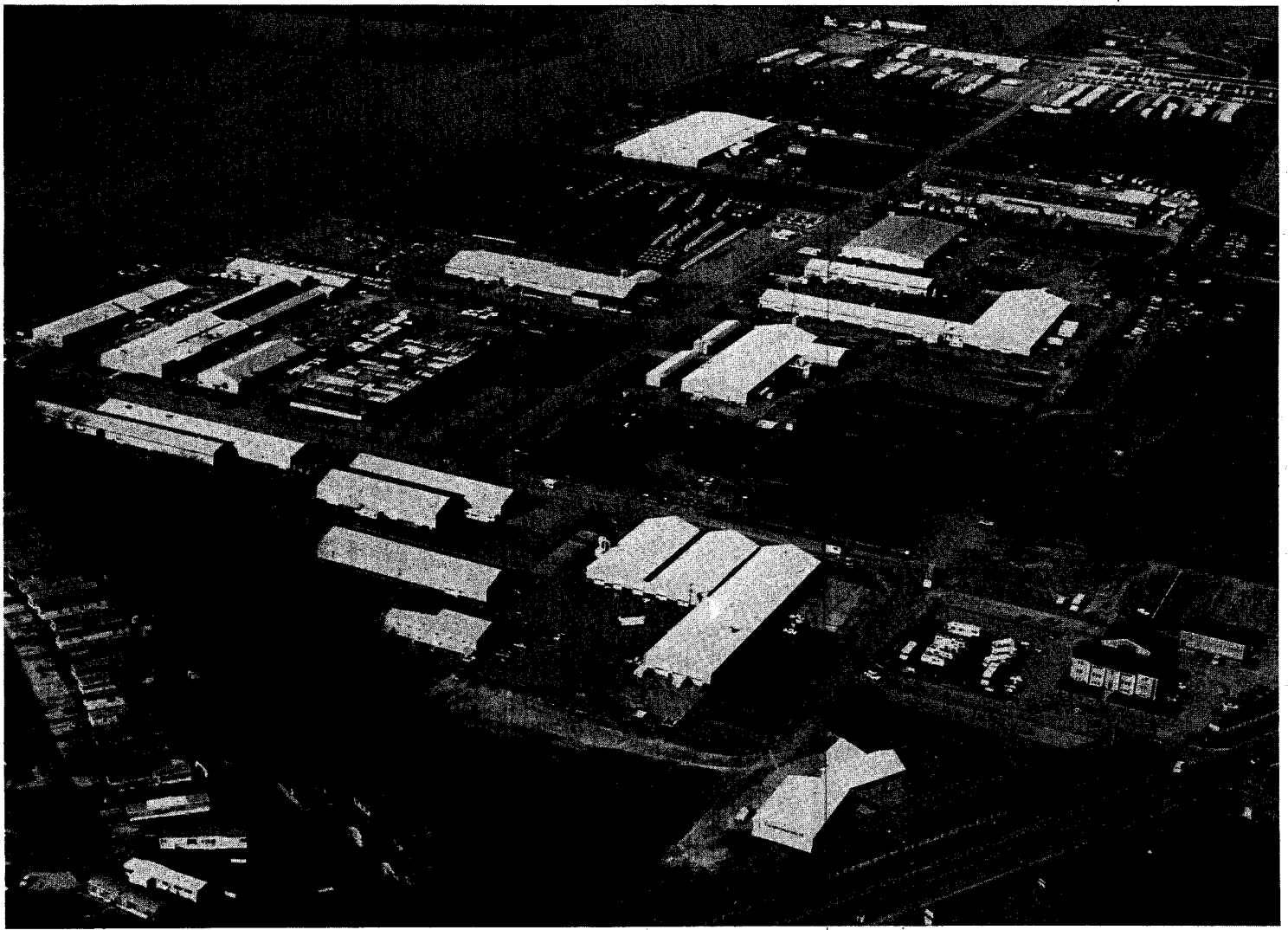

Coachmen Industries, Inc. was founded in Middlebury, Indiana, in 1964 by Claude, Keith and Tom Corson. The three brothers recognized business opportunities in the new and growing recreational vehicle (RV) industry and tried to combine their business experience in finance, marketing and manufacturing.

Their confidence in the RV industry was well founded. From first-year production that included 12 travel trailers, one pick-up truck camper and 80 truck caps, the

Company has become a diversified, full-line manufacturer of recreational vehicles under many well-known brand names with well over 449,000 units manufactured. The Company's RV product line includes travel trailers, fifth wheel trailers, motorhomes, truck campers, camping trailers and van conversions.

The Coachmen RV complex includes 120 acres with 588,000 square feet of assembly facilities under roof.



Coachmen®

RECREATIONAL VEHICLE CO.
P.O. Box 1000
Middlebury, Indiana 46540

The Coachmen recreational vehicles described in this manual incorporate components produced by Coachmen Industries, its divisions, and various other suppliers. During the product year, Coachmen may decide to produce units with different components and/or specifications than initially scheduled. All such changes are approved for use by Coachmen in order to maintain the quality standards associated with the Coachmen name. All illustrations and specifications contained in this owners manual are based on the latest product information at time of publication. Coachmen reserves the right to make changes in operations, materials, equipment and specifications at any time without notice. Coachmen assumes no responsibility for any error in type or print reproduction of specifications in this owners manual. Check with your Coachmen dealer for more information if you have specific questions.