

3/4" x 3/4" x 1/16" Aluminum angle 7-1/4" Lg.

3/4" x 3/4" x 1/16" Aluminum angle 3" Lg.

1" x 1" x 1/8" Aluminum angle 6-3/8" long

0.188 drill (2)

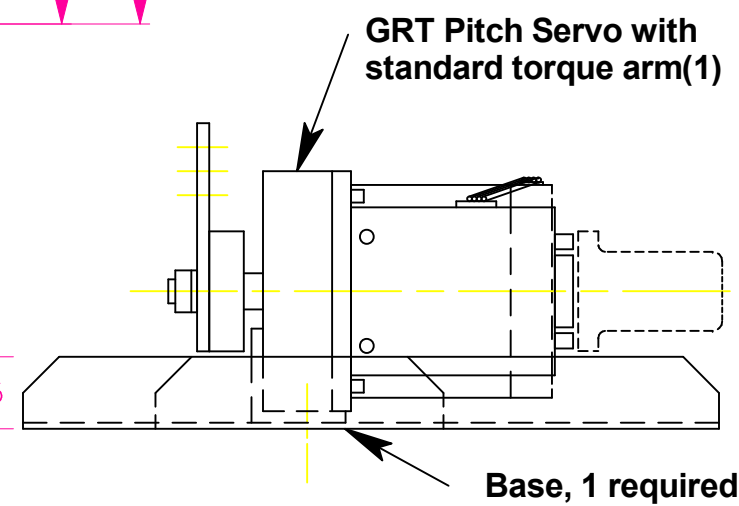
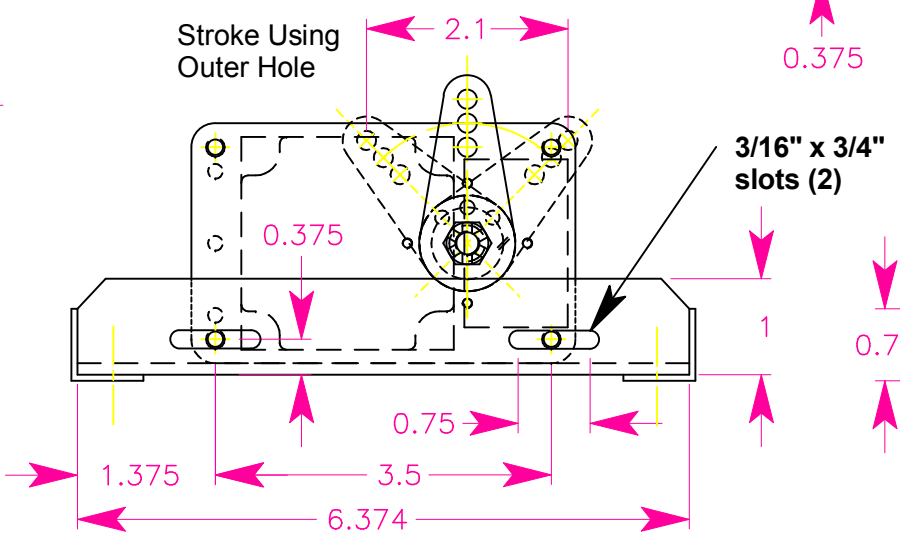
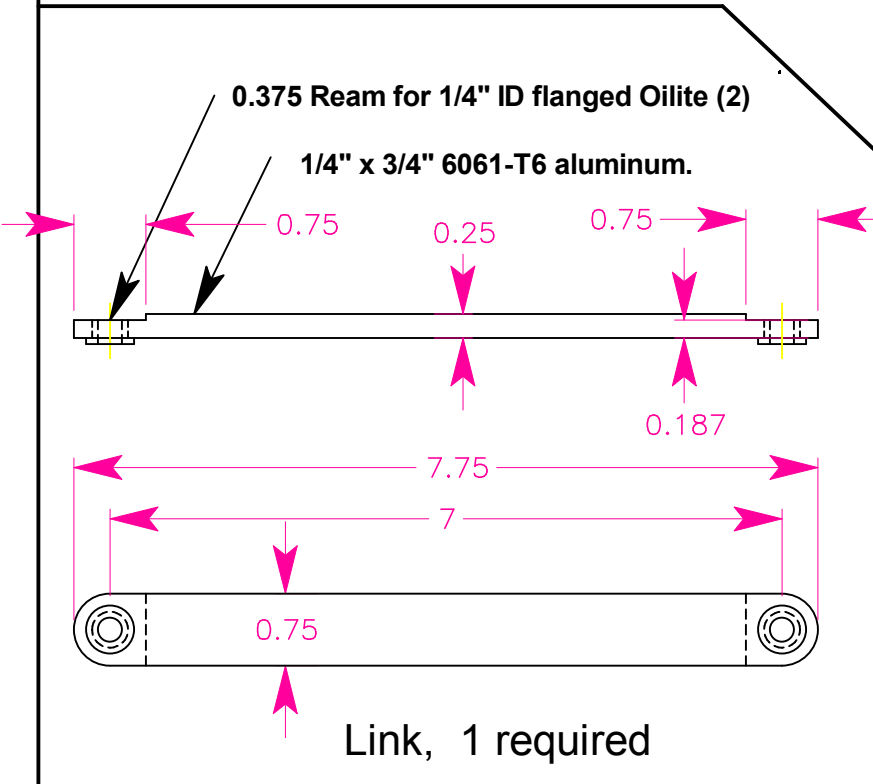
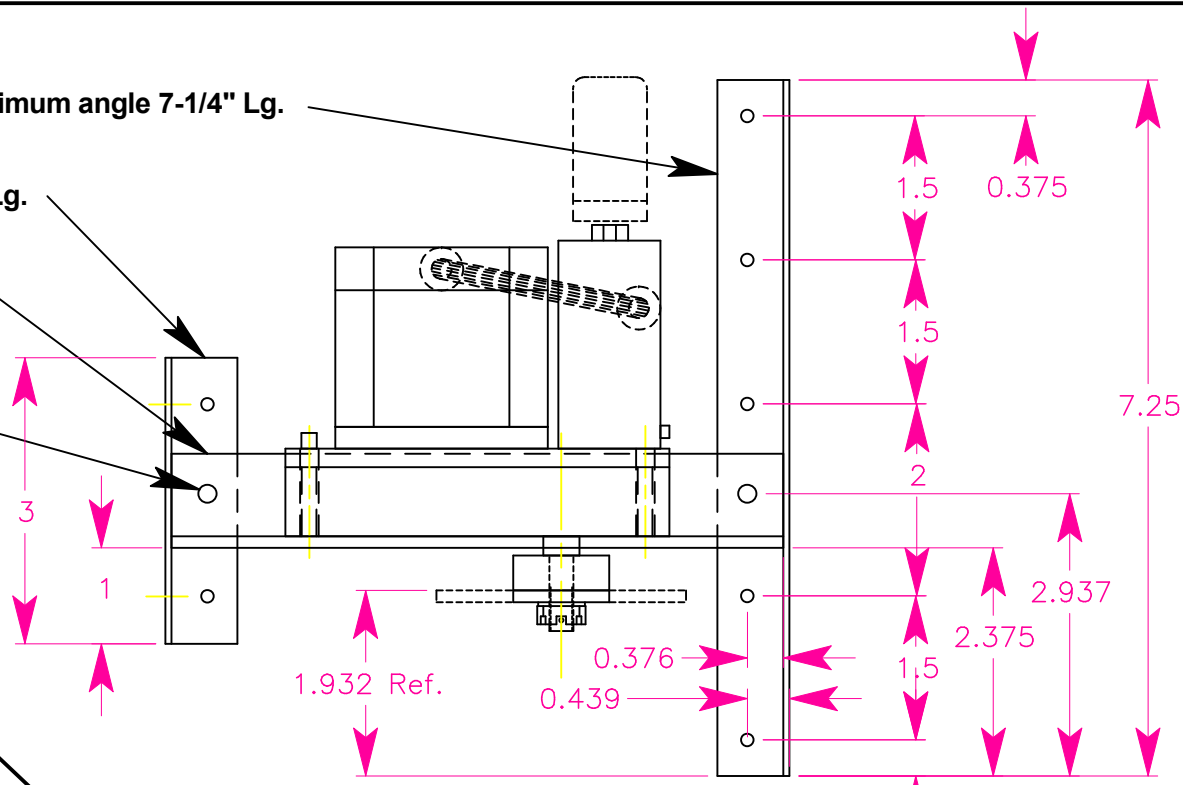
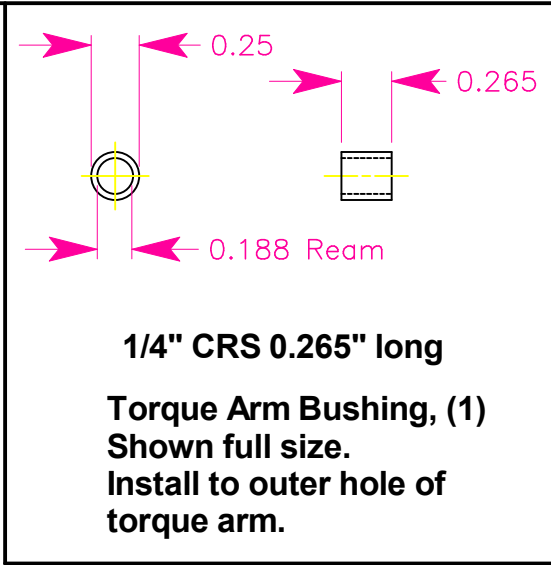

Sonex Forum ID: DCA Sonex

GRT Avionics Auto-pilot Pitch Servo Mounting
Oct. 01, 2011