

Conowingo Models



Debris Boat BD-5

HO Scale



www.conowingomodels.com
<https://www.facebook.com/ConowingoModels/>
conowingomodels@yahoo.com

September, 2023



Thank you for purchasing this kit!

The pushboat modeled in this kit is real. It was built by the US Army Corps of Engineers (USACE) in 1968, most likely in Philadelphia. It is somehow related to similar boats built at Gasconade, MO, which closed many years earlier.

BD-5 served as a debris boat with the Baltimore District of USACE from 1968 until sometime in the mid-late 1980s, when it was apparently sold off. The boat number BD-5 has since been placed on a newer boat. The name presumably was for Baltimore Division boat number five.

Being a debris boat meant it was used to clear debris out of navigable waterways. An example of this would be the removal of tree limbs from storm damage. During its' years with USACE, it had a front-end loader attached to the bow of the boat.

The only photos of this boat in service were taken during the recovery of Air Florida flight 90, which crashed into the Potomac River in Washington, D.C. on January 13,

1982.

<https://aviation-safety.net/database/record.php?id=19820113-0>

Lessons learned from this aviation accident were vital in shaping more formal procedures for aircraft deicing in the US and presumably worldwide.

BD-5 had two sister boats, BD-4 and BD-6, which were also involved in the recovery efforts mentioned above.

The boat featured a single, GM 220 hp diesel motor, which took it through the water at 10.6 mph. It would draught at 4 feet, thus the two- and three-foot markers on the hull.

After the boat was sold by the USACE in favor of a more modern replacement, it appears to have been converted into a truckable pushboat. This meant that it was used in smaller waterways to move barges. Due to its' size, it could be easily transported from one waterway to another via a lowboy. A crane most likely was used to facilitate the moving to/from the water.

Today, the former BD-5 sits, rusting away at a former welding shop in Northeast, MD. Its' future remains unclear as the engine sits beside it and there are many holes in the hull. We would like to see it moved to a museum, due to the history of the boat and its' overall uniqueness.

While this boat most likely had nothing to do with the world of railroading, it does make an interesting subject for your railroad to haul around. Building this kit is one of the ways that model railroaders can preserve history.

There is a 56-foot-long depressed center flat car that we built specifically to haul this boat around.

Supplied are the basic directions. For more tips, product recommendations and some additional instructions, please see conowingomodels.com Additionally, if the instructions are updated, the latest and greatest instructions are downloadable there. Also see the General Instructions Help file on the website for tips and techniques.

There are a number of options of what can be done with this kit. Read through the instructions to figure out how you want to build it. **Both the hull and waterline versions can be built utilizing the same set of instructions.**

BRACING AND PREP

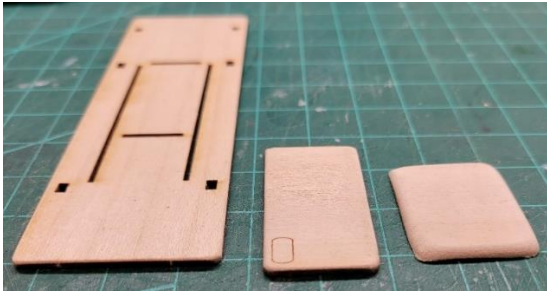

1. Cut out the three pieces shown above from their carrying trays. You will want to round the edges and corners as shown above. We used a medium grit sanding sponge. If you spend two minutes, you've probably over sanded them. From left to right, you have the deck, engine compartment cover and pilot roof.
2. You may also want to round the outside edges on the aft engine room piece. Glue into place the ship's wheel as well. You might want to wait until after the pilot room is assembled to paint the area above the pilot room windows. This is to eliminate the possibility of warping.

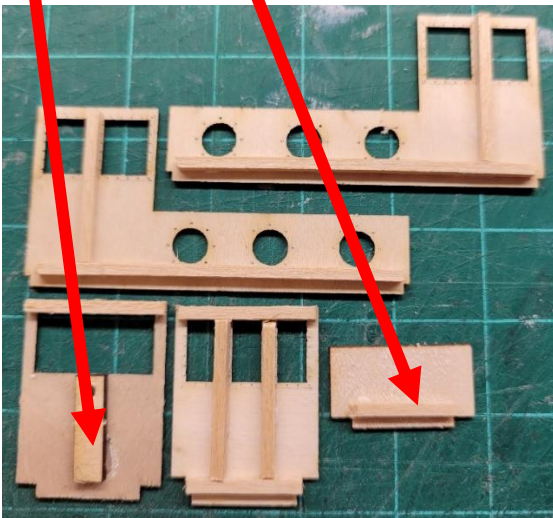

3. Brace the pilot and engine room as shown above, using 1/16 x 1/16 stripwood. Notice how some bracing goes all the way to the edge, while some pieces do not. This is important for final assembly.

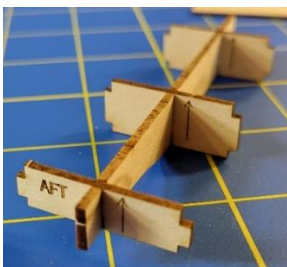



4. Assemble the keel as shown above. Do not glue. Ensure the arrows all point up and that the Aft piece is in the shortest slot. The waterline version will look somewhat different than the photo above, but it assembles the same way.

BUILDING THE HULL

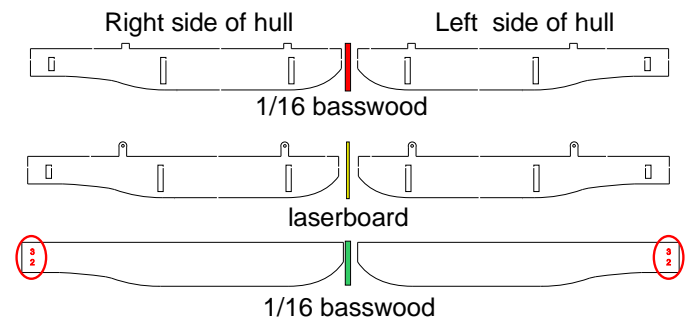
- ** The waterline version assembles the exact same way, except that there is no bottom piece and it looks a bit different.**



 right side sandwich

 left side sandwich

1. You will do this step and the following step twice—once for each side. Glue the hull sides as shown above on the sandwich references. Start by lining up the red layer with the yellow layer, so that the notches from the keel will eventually go into the slots. Be careful with the tiedown rings on the laserboard. They aren't brittle, but they can't take a beating either.
2. Glue the green layer next. It should be centered, on the fore, aft and bottom. It should be level with the top of the other two pieces. Ensure the pieces with the numbers (water level marks) are on the outside. They are shown circled on the first diagram and barely visible above.
3. Put level weights on both pieces to ensure they form a uniform bond and let dry.
4. Sand the corners front and rear corners as shown on the next page to round them.



Engine Room Roof

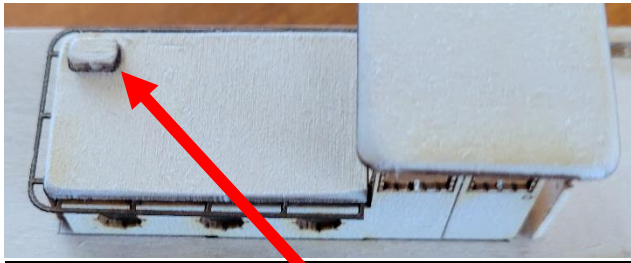

1. Sand the engine room hatch so the top corners are rounded. Shown with roof on model. Don't do this yet.

- Glue the hatch into place.

2. Take the laserboard railing and glue it under the roof for the engine room. Be careful as it can be brittle. You might want to add weights, so the piece comes out flat.

BUILDING THE BUMPERS

1. If you're building your boat with bumpers, cut out the four bumper sides from the laserboard as well as the two pieces of bumper from the 1/16 sheet.

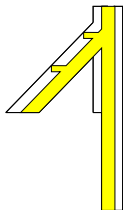

2. Once again, you're going to make two sandwiches. (We must've been hungry when we wrote these instructions...) Glue each of the 1/16 between two of the laserboard pieces as shown above in yellow. You want to form an I-beam.



3. Cut and glue into place a piece of 1/32 x 3/32 stripwood between/onto the edge of the laserboard pieces as shown above.

CUTTING OUT THE FRONT-END LOADER

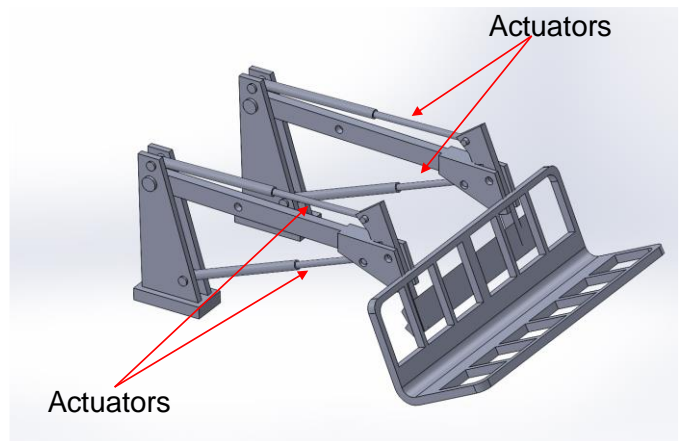

The front-end loader has a ton of supports on it that you will need to carefully remove. Use the diagram above for cutting them out and painting.

PAINTING

- **If you're using a custom mix of paints, reserve some for finishing touches at the end.**

These instructions are for how we painted it to match the real BD-5 in it's glory with the USACE. We suspect, based on current photos that it was painted relatively the same, post USACE service, except that the hull was a light grey with a red cheater stripe in the middle. (We supplied two sets on the decal sheet) Below the cheater stripe, it appears to have been either a dark grey or black. As always, we encourage you to be creative and deviate.

1. Paint the following pieces LIGHT YELLOW (glossy if you have it)
 - Engine room (except engine room roof) and pilot (5 pieces)
 - Be sure to paint the edges of all pieces and window edges.
 - Front end loader (silver on the actuators)
2. Paint the following pieces FLAT WHITE
 - Weather stripping for the windows. If you use a light coat, the screws will show through. (The pilot model was left yellow)
3. Paint the following pieces GLOSS WHITE
 - Roof for the pilot
 - Roof for the engine room
 - Railing for the engine room/pilot
 - Paint the undersides of both as well.
4. Paint the following pieces GLOSS LIGHT GREY
 - Deck (both sides)
 - Flagpole
 - Deck railings
5. Paint the hull as shown below

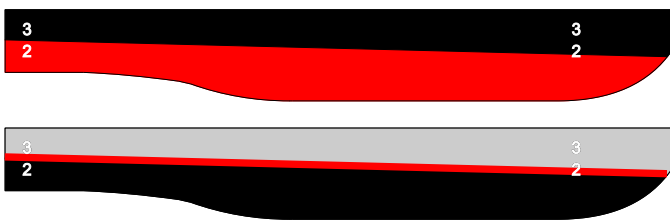

Top hull is USACE service. Below is post-USACE service. The ends should match up. On the waterline versions, it's easiest not to paint the bottom color, as that would presumably be under water.

- 5 pieces for the hull version *

- * Do not paint the bottom piece until the hull is otherwise complete

- 4 pieces for the waterline version

6. Paint the following pieces GLOSS YELLOW
 - Cleats x 5
7. Paint the following pieces FLAT ORANGE
 - Life rings x 2
8. Paint the following pieces GRIMY BLACK
 - Engine exhaust x 1
 - Navigation lights x2
 - Spotlight x1
9. Paint the following piece BROWN
 - Pilot wheel



10. When dry, paint the navigation lights as shown above.
11. When dry, paint the interior of the spotlight silver.

HULL ASSEMBLY

1. We recommend you find a surface (such as a 1 x 3 inch weight) that will allow you to place the deck inverted. This should give you enough clearance to put the hull sides together without crushing the tiedown rings.



2. With the deck inverted, dry fit the keel and hull sides. (Shown right side up.)

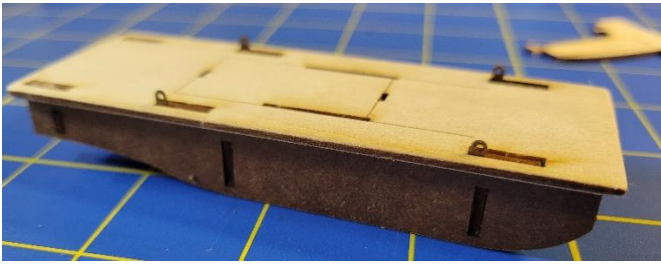

- The four notches on the top of the hull sides should slide nicely into the deck. When you're happy with the fit, glue into place. A little bit of glue or putty on top can be used to make the hole flush and unnoticeable. Yours will look different as this is an early pilot model.
- Glue the stern and bow pieces into place.
- If you are building the full-hull version, wet the large, 1/32 hull bottom. It will start to curl.
- Fit the hull bottom into place, beginning at the front of the boat and working your way back, matching the contour of the hull sides. Once you're happy with the fit, glue it into place. You may choose to use rubber bands, stripwood of whatever you have on your workbench to apply the proper pressure. There will be extra length to that piece. Don't cut it off yet. We'll let you know when. If you cut it now, it will shrink and you'll have a gap.

WINDOWS

- Cut out the acetate pieces for the windows and glue them into place using a product that will not cause crazing. You may need to trim them, depending on how you braced the walls.

PILOT/ ENGINE ROOM ASSEMBLY

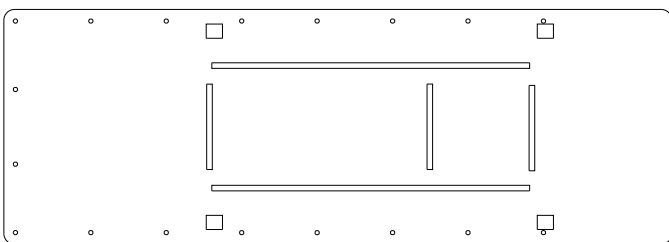

- Use a slow-drying glue for the following steps. We recommend you dry fit the walls into place to ensure you don't need to cut any bracing. You might also consider using CA to bond the bracing into place.

- Glue the side walls into place, using the tabs on the walls and slots in the deck.
- Glue the pilot front and rear walls into place, followed by the aft engine room wall, in the same manner as above.
- Glue the pilot wheel into place.

Hull ASSEMBLY

- (Full hull version) Once the hull is dry, cut the bottom piece flush with the aft hull piece.
- Fill any gaps with wood putty
- Finish contouring the hull itself.
- Glue into place the front-end loader/ bumpers.

DECALS

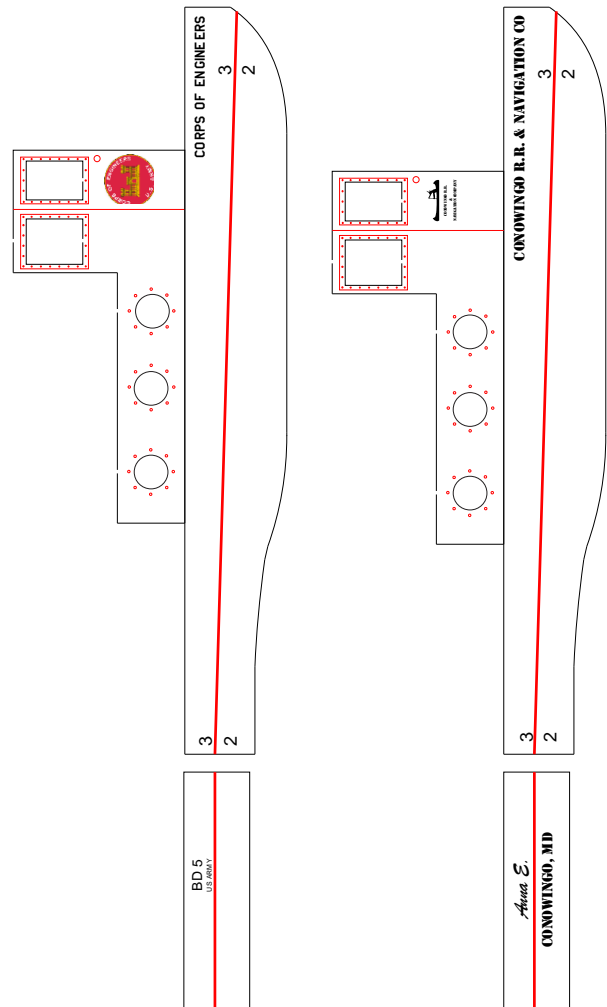

We included two sets of decals with each kit. Decide which you would like to do The US Army Corps of Engineers decals are shown on top. The bottom version is completely fictional.

5. We recommend working from smallest to largest.
6. The stripe should go completely around the boat.

DETAILS

1. Glue the engine cover into place, being careful not to break the railing.

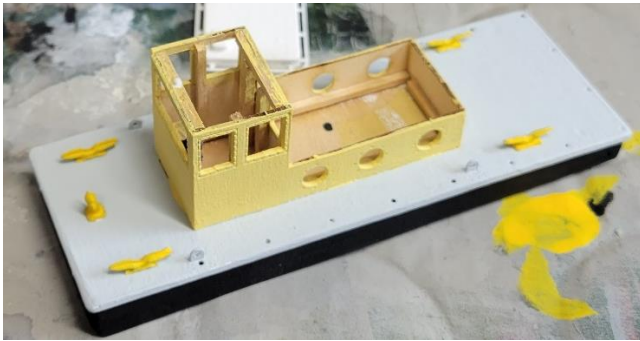

2. Glue the cleats into place as shown above.
3. (Optional) Take the included toothpick and cut to desired length for what we believe to be a flagpole. Based on the height of the pilot house, it's probably about 6 feet tall. There is a flag visible on top of the pilot house, so this "flagpole" may have had some other use.
 - In the Air Florida crash photos, the flag pole tilts slightly aft. However, it currently is bent forward, an unfortunate sign of its' current status.
 - Elongate the hole accordingly and glue the flagpole into place.
4. Cut and glue the deck railings into place (as desired). If not, we recommend you fill in the holes.
5. Glue the pilot house roof into place, ensuring it sits squarely on top.
6. Glue in place the navigation lights – red on the left. Green on the right.
7. Glue into place the spotlight and the engine exhaust.

8. Touch up any paint blemishes as needed.
9. Weather as desired.
10. Please share your photos on our Facebook page!
<https://www.facebook.com/ConowingoModels>

Once again, thank you for your purchase!

If there are any parts missing, please e-mail us conowingomodels@yahoo.com with what you need to complete the kit and we'll send it your way. I'm usually a one-man shop and I do occasionally miss things. Also, suggestions for improvement are welcome.

Please send photos!

See the Conowingo Models website
www.conowingomodels.com

Or our Facebook page
<https://www.facebook.com/ConowingoModels/>
for more exciting, funky buildings and rolling stock for your model railroad!

Many thanks to Mark Schreier, Jeff Grove, Steve Milley and Greg Cassidy for their help with this endeavor. Also thanks to US Army Corps of Engineers historians Eric Reinert and Andrew Payson for providing information and context.

Thank you!



Recent photo showing the current colors and aging.



Recent photo showing the current colors as well as the two and three-foot markers that were welded onto the hull. The hull is marked like this in four places.



Photo of BD-5 taken during Air Florida 90 recovery efforts in January, 1982. (US Army Corps of Engineers photo)



Photo of BD-5 taken during Air Florida 90 recovery efforts in January, 1982. (US Army Corps of Engineers photo)



Photo of BD-5 taken during Air Florida 90 recovery efforts in January, 1982. (US Army Corps of Engineers photo)



One of the pilot models was finished by Greg Cassidy. <https://www.youtube.com/watch?v=3E5nqQVSLjg> to see Greg's incredible build. Warning- Greg did such a fantastic job that you'll need a tetanus shot!