



INTAKE MANIFOLD INSTRUCTIONS

(BEFORE INSTALLATION, PLEASE READ THESE INSTRUCTIONS COMPLETELY)

Top Street Performance Velocity series are designed for GM Small Block Gen III and IV LS based engines and Ford Coyote engines. There are Velocity Intake Manifolds available for each of the three GM OE LS cylinder head types, LS1/2/6 (cathedral port), LS3 (rectangular port), and LS7 (raised rectangular port). All of these intake manifolds are designed to work with OE or aftermarket cylinder heads as long as the head is configured with the intake flange bolt pattern and intake port opening locations matching the appropriate OE application, GM Small Block Gen III and IV engines LS based engines and Ford Coyote engines.

Manifold Kit Contents:

- (8) O-Ring Port Gasket Kit
- (1) Intake Manifold and Mounting Hardware (Includes Studs and Washers)
- (1) 1/4" NPT Hose Barb Fitting
- (3) 3/8" NPT Hose Barb Fitting

Fuel Rail Kit Contents:

- (2) Fuel Rail, High Volume, configured with (AN-8) ports
- (1) Fuel Rail mounting hardware kit (consisting of Head Cap Screws, Washers, and Brackets)
- (1) Steel braided crossover fuel line, configured with (AN-6) fittings
- (4) Fuel Rail Fittings (AN-8)
- (1) Fuel Rail Block-off Plug (AN-8)

INSTALLATION:

Velocity intake manifolds will have the best fitment when the block and heads are machined to standard OE dimensions. If the block or head deck surfaces have been milled significantly, the alignment of the mounting bolt holes and the port flange openings to the cylinder head may be shifted and not match-up.

INSTALLATION OF THE INTAKE MANIFOLD

1. Before installing the intake manifold base perform a test fit of the intake manifold without the O-rings or gaskets installed. Check for proper alignment of mounting points and sufficient hood clearance on vehicles.

a. **NOTE:** All Ford 5.0L "Coyote" Platform Intakes arrive with a stabilizer bar fastened with two bolts on either side at the front and the rear of the intake, these must be removed as these are installed for stability during shipping and are NOT used/needed in the installation on the intake. Failure to remove bars will result in inability to install the intake.

2. Check the port opening alignment. Test fit fuel and vacuum plumbing, throttle linkage, wiring, etc. to ensure there are not any fit issues before performing the final intake manifold installation.

3. For final installation, install the (8) O-rings provided in the mounting flange O-ring grooves. To make sure the O-rings do not fall from the grooves, apply a light coat of grease to the O-rings.
4. Install the mounting studs into the cylinder heads. Apply engine oil to the threads and thread in the stud until all of the threads are engaged by hand.
5. Put the intake manifold into place on the mounting flange. Be sure that all of the O-rings are still in the grooves and are not being crushed between the flanges.

WARNING! Threads in the aluminum cylinder head will not withstand abuse. Care must be taken to have proper thread alignment engagement and to tighten the fasteners to the proper specifications.

6. Install the washers and bolts provided; engine oil should be applied to the threads. Gently tighten the bolts working side to side and out from the center (see the following tightening sequence diagram), until manifold is seated on the mounting flanges and the O-rings have been compressed. In two steps, tighten the mounting nuts first to 44 in-lbs. and then to 89 in-lbs. following the recommended factory bolt tightening sequence.

Manifold Tightening Sequence (GM LS1/2/3/6/7)

In two steps, tighten the mounting nuts first to 44 in-lbs. and then to 89 in-lbs. following the recommended factory bolt tightening sequence (shown below).

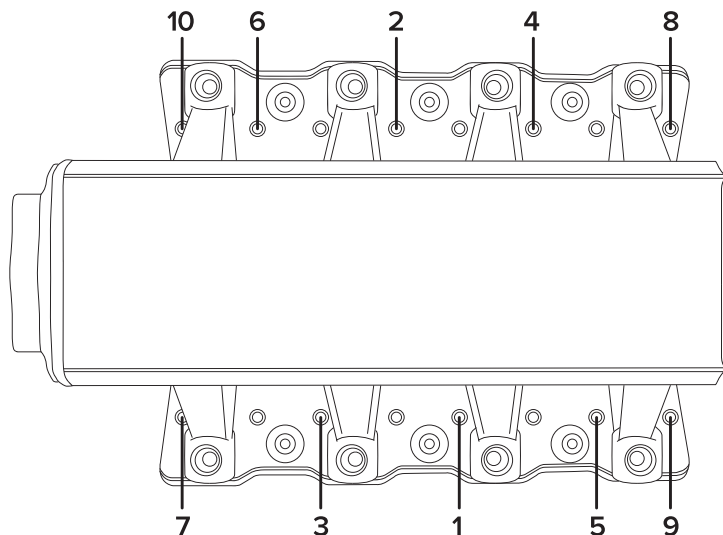

Manifold Tightening Sequence (11-15 Ford 5.0L Coyote)

In two steps, tighten the mounting nuts first to 44 in-lbs. and then to 89 in-lbs. following the recommended factory bolt tightening sequence

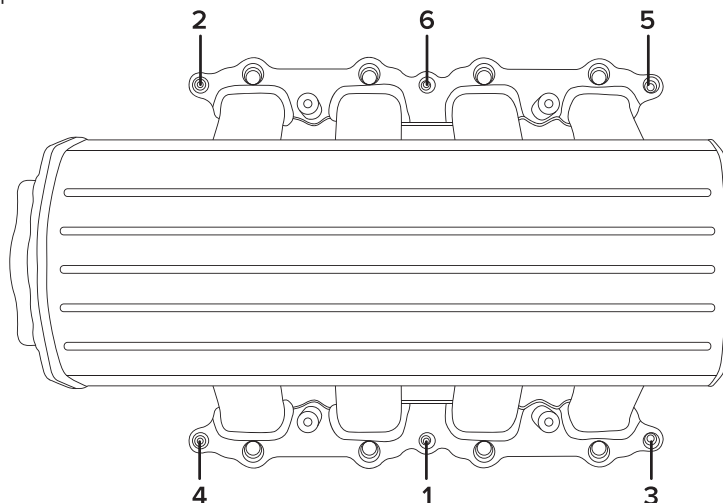

7. On the underside of the intake manifold plenum area, there is a flange with (4) holes tapped. (1) 1/4" NPT and (3) 3/8" NPT fittings are provided. These ports will provide ample vacuum port sources for EFI manifolds. Any of these ports can be utilized depending on required needs. Any unused ports can be easily plugged or NPT fitting can be capped for later use as needed.

INSTALLATION OF THE FUEL RAILS

1. Apply a silicone lubricant to the O-ring on the inlet end of the fuel injectors and insert the fuel injectors into the ports in the fuel rail. To insert the injector without tearing the O-ring, gently rock the injector in the inlet of the port while applying pressure to insert the injector.
2. Position the injectors to properly orient the wiring plugs, apply silicone lubricant to the injector outlet O-rings, and insert all four injectors into the injector bosses in the base intake manifold applying gentle downward pressure onto the fuel rail.
3. Once the injectors are inserted into the intake manifold, place the washers on the supplied socket head cap screws.
4. Apply a drop of oil to the socket head cap screws, place the spacers between the fuel rail and the mounting bosses, and thread in the socket head cap screws.
5. Tighten the fasteners in two steps 44 in lbs. for the first step and 89 in-lbs. for the second step.
6. Check and make sure the injector is floating on the O-ring. Rotate the injector back and forth to confirm that there is no load on the injector body.
7. The fuel rail is designed to provide enough flow and volume to dampen fuel pressure oscillations and variations at the inlet of the fuel injectors. The fuel rails are machined to receive the supplied (AN-8) fittings for the ends of the fuel rails.
8. Once Fuel lines have been attached to the fuel rails, check for fuel leaks. KOEO (Key on, engine off) This will allow the fuel pump to prime the fuel lines and create pressure to check for leaks.
9. Once Intake manifold have been mounted and checked for leaks. Before running the vehicle the **ECU must be tuned to the intake manifold**. If engine is run without proper tuning it may cause severe damage and/or engine failure.