

TABLE OF CONTENTS

WIREROPE USAGE	2-4
FLEX-X6 WIRE ROPE	5
7-FLEX WIRE ROPE	6, 7
FLEX-X9 WIRE ROPE	8
POWER FLEX-19 WIRE ROPE	9
STARLIFT PLUS WIRE ROPE 35 X 7	10
WIRE ROPE INSTALLATION AND HANDLING	11, 12
SCREW PIN ANCHOR SHACKLES	13
BOLT SAFETY ANCHOR SHACKLES	14
FIST GRIP CLIPS	15
WIRE ROPE CLIPS	16
SHEAVE WORKSHEET	17
DIVIDED CRANE BLOCK WORKSHEET	18
ALLOY SWIVEL EYE HOOKS	19
CARBON AND ALLOY SWIVEL EYE HOOKS	20
WIRE ROPE DESIGN	21
WIRE ROPE STRENGTHS AND WEIGHTS	22, 23
WIRE ROPE NOMINAL STRENGTHS	24, 25
WIRE ROPE SLINGS, CALCULATING LOADS	26, 27
WIRE ROPE INSPECTION CRITERIA	28
MECHANICAL SPLICE SLINGS-IMPROV. PLOW STEEL	29-31
MECHANICAL SPLICE SLINGS-EX. IMPROV. PLOW STEEL	30-32
MECHANICAL SPLICE SLINGS-CABLE LAID BODY	33



for all your lifting needs - 1 800 950 3183 or 1 800 568 WIRE

TABLE OF CONTENTS, CONTINUED

DROP FORGED EYE BOLTS	34, 35
DROP FORGED EYE BOLTS (SHOULDER)	36
DROP FORGED EYE NUTS	37
DROP FORGED HEAVY DUTY EYE NUTS & PAD EYES	38
STEEL SWAGE BUTTONS	39
STANDARD SWAGE BUTTONS	40
SPECIAL STOCK SWAGE BUTTONS	41
CAST DRUMLINE & MACHINED END FERRULES	42
HOIST CABLE WORKSHEET	43
OPEN WEDGE SOCKETS & ONE SHEAVE SNATCH	44
OPEN SHEAVE SNATCH BLOCKS WITH HOOK	45, 46
OBLONG MASTER RINGS	47
PIPE CARRIER SLINGS	48
THREADED STUDS	49
THREADED STUDS AFTER SWAGE	50
SWAGED SOCKET/BOOM PENDANT ASSEMBLIES	51-53
SPECIAL BOOM PENDANT ASSEMBLIES	54, 55
OPEN BRIDGE BOWL SOCKETS	56, 57
LIFTING CLAMPS	58-64



for all your lifting needs - 1 800 950 3183 or 1 800 568 WIRE

WIRE ROPE USAGE

Rope End Preparations:

For a number of applications—such as tight openings in drums, or other complicated systems—there may be a need for making special end preparations. When these are required, there are about four basic designs (and combinations) to choose from (see illustration below). Whenever possible end preparations should be removed after the rope is installed. Becketts are used when another rope is needed to pull the new rope into place. *Wire rope should not be shortened, lengthened or terminated by the use of a knot.*

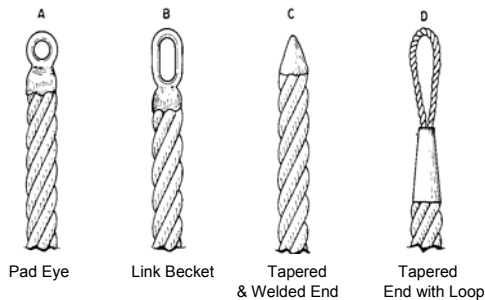

Figure 1. Becketts, or end preparations, are used on wire rope ends when another rope is needed to pull the operating rope into place. Four commonly used becketts are illustrated.

Rope End Terminations:

The rope end must be fastened to the mechanism so that force and motion are transferred efficiently. End terminations thus become items of great importance for transferring these forces. Each basic type of termination has its own individual characteristic. Hence, one type will usually fit the needs of a given installation better than the others.

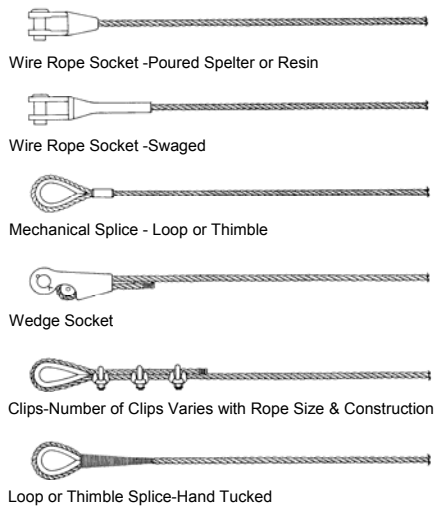

Figure 2. End fittings or terminations are available in many designs, some of which were developed for particular applications. The six shown are among the most commonly used.

It should be noted that not all end terminations will develop the full strength of the wire rope used. To lessen the possibility of error, the wire rope industry has determined terminal efficiencies for various types of end terminations. Holding power calculations can be made for the more popular end terminations (see figure 2) based on efficiency factors in the tables which follow.

Socketing:

Improperly attached wire rope terminals lead to serious—possibly unsafe—conditions. To perform properly, all wire rope elements must be held securely by the terminal. If this is not accomplished, the strands will become unequally loaded and it is likely that a strand will become "high". A high strand condition is illustrated in Figure 48. In the case shown, selective abrasive wear of the high strand will necessitate early removal of the rope.

Poured Sockets - Zinc or Resin

Poured sockets have traditionally been the method for determining the rope's actual breaking strength. All other types of terminations have been compared to poured sockets. Their efficiency is therefore established to be 100% for all grades and constructions of rope.

Rope assemblies with poured attachments are generally used as a straight tension member where the rope body does not contact the load and is otherwise kept free from distortion or physical abuse. In such cases, where the rope acts as a pendant line, the minimum recommended design factor is 3.0. If the assembly is used as a sling, then the minimum recommended design factor of 5.0 should be used to calculate the rated capacity.

Length tolerances for poured attachments can be somewhat more stringent than other types of assemblies. The manufacturer should be contacted and agreement reached before the order is placed. Tolerance as small as plus or minus 1/8" is not out of the ordinary for this type of assembly. Specifications such as type of fitting, pin orientation (See Appendix B), whether zinc or resin should be used, and type of application should also be supplied to the manufacturer when ordering

TERMINAL EFFICIENCIES (APPROXIMATE)		
Type of Termination	Efficiency	
	Rope with IWRC*	Rope with FC**
Wire Rope Socket (Spelter or Resin)	100%	100%
Swaged Socket (Reg. Lay Ropes Only)	100%	Not
Mechanical Spliced Sleeve (Flemish Eye)		
1" dia. and smaller	95%	92-1/2%
Greater than 1" dia thru 2"	92-1/2%	90%
Loop or Thimble Splice-Hand Spliced (Tucked)(Carbon Steel Rope)		
1/4"	90%	90%
5/16"	89%	89%
3/8"	88%	88%
7/16"	87%	87%
1/2"	86%	86%
5/8"	84%	84%
3/4"	82%	82%
7/8" thru 2-1/2"	80%	80%
*IWRC=Independent Wire Rope Core		
**FC=Fiber Core		

WIRE ROPE USAGE

these types of assemblies.

When preparing a wire rope for socketing it is of extreme importance to follow recommended procedures. Those inexperienced in the socketing process should not try to fabricate assemblies without first getting expert training. It is far better to leave fabrication of this type of assembly to the experts. It is recommended that all poured sockets, whether they be zinc or resin, be proofloaded.

TERMINAL EFFICIENCIES (APPROXIMATE) Efficiencies are applicable to nominal wire rope strengths		
Type of Termination	Efficiency Rope with IWRC*	
Loop or Thimble Splice-Hand Spliced (Tucked) (Stainless Steel Rope)		
1/4"	80%	
5/16"	79%	
3/8"	78%	
7/16"	77%	
1/2"	76%	
5/8"	74%	
3/4"	72%	
7/8"	70%	
Wedge Sockets***	Efficiency Rope with IWRC* Rope with FC**	
(Depending on Design)	75% to 80%	75% to 80%
Clips***		
(# of clips varies with size of rope)	80%	80%
*IWRC=Independent Wire Rope Core		
**FC=Fiber Core		
***Typical values when applied properly. Refer to fittings manufacturers for exact values and method.		

Wire Rope Clips

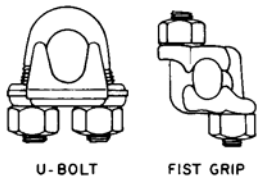

Wire rope clips are widely used for making end terminations.

Clips are available in two basic designs; the U-bolt and fist grip (Fig. 29). The efficiency of both types is the same. When using U-bolt clips, extreme care must be exercised to make certain that they are attached correctly; i.e., the U-bolt must be applied so that the "U"

section is in contact with the dead end of the rope (Fig. 30). Also, the tightening and retightening of the nuts must be accomplished as required.

Use only forged clips for critical, heavy duty, overhead loads, such as support lines, guy lines, towing lines, tie downs, scaffolds, etc.

Malleable clips are to be used for making eye termination assemblies only with right regular lay wire rope and only for light duty uses with small applied loads, such as hand rails, fencing, guard rails, etc.

HOW TO APPLY CLIPS

U-BOLT CLIPS (Table 1)

Recommended Method of Applying U-Bolt Clips to Get Maximum Holding Power of the Clip. The following is based on the use of proper size U-Bolt clips on new rope.

1. Refer to table 6 in following these instructions. Turn back specified amount of rope from thimble or loop. Apply first clip one base width from dead end of rope. Apply U-Bolt over dead end of wire rope with live end resting in saddle. Tighten nuts evenly, alternating from one nut to the other until reaching the recommended torque.
2. When two clips are required, apply the second clip as near the loop or thimble as possible. Tighten nuts evenly, alternating until reaching the recommended torque. When more than two clips are required, apply the second clip as near the loop or thimble as possible, turn nuts on second clip firmly, but do not tighten. Proceed to Step 3.
3. When three or more clips are required, space additional clips equally between first two - take up rope slack - tighten nuts on each U-Bolt evenly, alternating from one nut to the other until reaching recommended torque.
4. Apply first load to test the assembly. This load should be of equal or greater weight than loads expected in use. Next, check and retighten nuts to recommended torque.
5. Inspect periodically and retighten to recommended torque.

In accordance with good rigging and maintenance practices, the wire rope and termination should be inspected periodically for wear, abuse and general adequacy.

A termination made in accordance with the above instructions, and using the number of clips shown, has an approximate 80% efficiency rating. This rating is based upon the nominal strength of wire rope. If a pulley is used in place of a thimble for turning back the rope, add one additional clip.

The number of clips shown is based upon using right regular or lang lay wire rope, 6 x 19 classification or 6 x 37 classification, fiber core or IWRC, IPS or EIP. If Seale construction or similar large outer wire type construction in the 6 x 19 classification is to be used for sizes 1 inch and larger, add one additional clip.

The number of clips shown also applies to right regular lay wire rope, 8 x 19 classification, fiber core, IPS, sizes 1-1/2 inch and smaller; and right regular lay wire rope, 19 x 7 classification, IPS or EIP, sizes 1-3/4 inch and smaller.

For other classifications of wire rope not mentioned above, it may be necessary to add additional clips to the number shown.

If a greater number of clips are used than shown in the table, the amount of rope turnback should be increased proportionately. **ABOVE BASED ON USE OF PROPER SIZE U-BOLT CLIPS ON NEW ROPE.**

IMPORTANT: Failure to make a termination in accordance with aforementioned instructions, or failure to periodically check and retighten to the recommended torque, may cause a reduction in efficiency rating.

FIST GRIP CLIPS (See Table 1)

Recommended Method of Applying Fist Grip Clips to Get Maximum Holding Power of the Clip. The following based on the use of proper size fist grip clips on new rope.

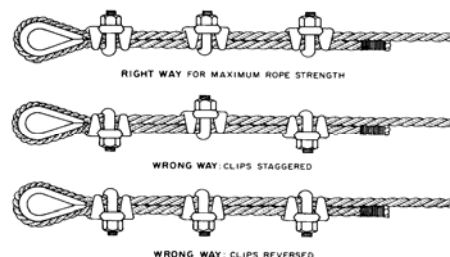

Figure 3. The correct way to attach U-bolts is shown at the top; the "U" section is in contact with the dead end of the rope and is clear of the thimble.

WIRE ROPE USAGE

Refer to table 1 following these instructions. Turn back specified amount of rope from thimble or loop. Apply first clip one base width from dead end of rope. Tighten nuts evenly, alternating from one nut to the other until reaching the recommended torque.

2. When two clips are required, apply the second clip as near the loop or thimble as possible. Tighten nuts evenly, alternating until reaching the recommended torque. When more than two clips are required, apply the second clip as near the loop or thimble as possible. Turn nuts on second clip firmly, but do not tighten. Proceed to Step 3.

3. When three or more clips are required, space additional clips equally between first two—take up rope slack—tighten nuts on each Fist Grip evenly, alternating from one nut to the other until reaching recommended torque.

4. Apply first load to test the assembly. This load should be of equal or greater weight than loads expected in use. Next, check and retighten nuts to recommended torque.

5. Inspect periodically and retighten to recommended torque.

In accordance with good rigging and maintenance practices, the wire rope and termination should be inspected periodically for wear, abuse and general adequacy.

A termination made in accordance with the above instructions, and using the number of clips shown has an approximate 80% efficiency rating. This rating is based upon the nominal strength of wire rope. If a pulley is used in place of a thimble for turning back the rope, add one additional clip.

The number of clips shown is based upon using right regular or lang lay wire rope, 6 x 19 classification or 6 x 37 classification, fiber core or IWRC, IPS or EIP. If Seale construction or similar large outer wire type construction in the 6 x 19 classification is to be used for sizes 1 inch and larger, add one additional clip.

The number of clips shown also applies to right regular lay wire rope, 8 x 19 classification, fiber core, IPS, sizes 1-1/2 inch and smaller; and right regular lay wire rope, 18 x 7 classification, fiber core, IPS or EIP sizes 1-3/4 inch and smaller.

For other classifications of wire rope not mentioned above, it may be necessary to add additional clips to the number shown.

If a greater number of clips are used than shown in the table, the amount of rope turnback should be increased proportionately.

ABOVE BASED ON USE OF PROPER SIZE FIST GRIP CLIPS ON NEW ROPE.

IMPORTANT: Failure to make a termination in accordance with aforementioned instructions, or failure to periodically check and retighten to the recommended torque, may cause a reduction in efficiency rating.

Wedge Sockets

One of the more popular end attachments for wire rope is the wedge socket. For field, or on the job attachment, it is easily installed and quickly dismantled. The following procedures are important for safe application of wedge sockets:

Inspection/Maintenance Safety

- Always inspect socket, wedge and pin for correct size and condition before using.
- Do not use part showing cracks.
- Do not use modified or substitute parts.
- Repair minor nicks or gouges to socket or pin by lightly grinding until surfaces are smooth. Do not reduce original dimension more than 10%. Do not repair by welding.
- Inspect permanent assemblies annually, or more often in severe operating conditions.

Consult the socket manufacturer for recommendations regarding the specific use and reapplication of wedge sockets.

Assembly Safety

- Use only with standard 6 to 8 strand wire rope of designated size. For intermediate size rope, 9/16" diameter and larger, use next larger size socket. For example: When using ~16" diameter wire rope use a 5/8" Wedge Socket Assembly.

Welding of the tail on standard wire rope is not recommended. The tail length of the dead end should be a minimum of 6 rope diameters.

- Align live end of rope, with center line of pin.
- Secure dead end section of rope.
- **DO NOT ATTACH DEAD END TO LIVE END.**
- Use a hammer to seat Wedge and Rope as deep into socket as possible before applying first load.

To use with Rotation Resistant wire rope (special wire rope constructions with 8 or more outer strands) ensure that the dead end is seized, welded or brazed before inserting the wire rope into the wedge socket to prevent core slippage or loss of rope lay. The tail length of the dead end should be a minimum of 20 rope diameters but not less than 6" (See Illustration).

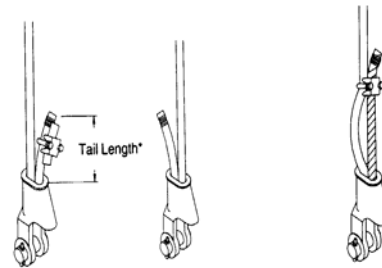

RIGHT WRONG WRONG

* Tail Length

Standard 6 to 8 strand wire rope

A minimum of 6 rope diameters, but not less than 6".

(i.e. - For 1" rope: Tail Length = 1"x6=6")

Rotation Resistant Wire Rope

A minimum of 20 rope diameters, but not less than 6".

(i.d. - For 1" rope: Tail Length = 1"x20=20")

Figure 4. The wedge socket is a very popular end attachment; it is easily installed and quickly dismantled. But it must be applied correctly.

Operating Safety

- Apply first load to fully seat the Wedge and Wire Rope in the socket. This load should be of equal or greater weight than loads expected in use.
- Efficiency rating of the Wedge Socket termination is based upon the nominal strength of Wire Rope. The efficiency of a properly assembled Wedge Socket is 80%.
- During use, do not strike the dead end section with any other elements of the rigging (Called two blocking).
- Do not shock load.

Wire Rope Users Manual, Third Edition

Copyright , © 1993

Wire Rope Technical Board

P.O. Box 286

Woodstock, Maryland 21163-0286

NOTE:

LiftPRO by NESCO, INC.

assumes no responsibility for the misuse or misapplication of any of its products. Products are provided with the express understanding that the purchaser and/or user are thoroughly familiar with the correct application and proper use. Warnings and definitions are provided as an aid to the user in understanding correct application and proper use. These charts are not a substitute to proper training.

FLEX-X6 WIRE ROPE

LiftPRO & WIRECO WIRE ROPE give you FLEX-X 6, the Six-Strand Rope of Choice!

FLEX-X 6 Provides:

- STABILITY
- RESISTANCE TO CRUSHING
- RESISTANCE TO BENDING FATIGUE
- RESISTANCE TO ABRASION
- STRENGTH

Most applications for wire rope are extremely demanding. Wire rope must resist crushing, bending fatigue and abrasion. For example, clamshell closing lines must resist bending fatigue and boom hoists are subject to pressures that cause crushing. Overhead hoists test the stability and strength of a wire rope. All drum-related applications demand a rope that will spool and operate smoothly and dependably.

If you recognize these typical conditions, the FLEX-X 6 is for you! FLEX-X 6 users receive superior performance and increased service life in many applications compared to the ropes they previously employed.

When compared to conventional 6 stand ropes, FLEX-X 6 provides greater surface area and more steel per given diameter, which increases stability and strength. This results in longer service life and less sheave and drum wear. *It also lowers your cost of operation!*

FLEX-X versus standard 6 x 26 WS

Drum scrubbing between the lead line and the previous wrap is reduced. The smooth contact creates less interference, less metal loss and wire deformation.

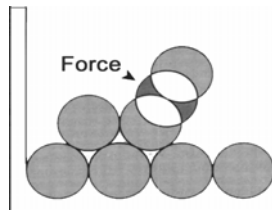

The increased surface area of Flex-X 6 can be seen in the comparison of contact points of a standard 6 x 26 WS (left) and Flex-X 6 (right).

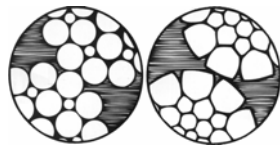

Contact forces are spread on sheave and drum grooves, wear is reduced and corrugation prevented.



Flex-X 6 Class Bright		
Rope Dia. in Inches	Nominal Strength tons of 2,000 lb.	Approx Weight Per foot lbs.
3/8	8.8	0.32
7/16	11.9	0.41
1/2	15.3	0.55
9/16	19.3	0.70
5/8	22.7	0.86
3/4	32.4	1.25
7/8	43.8	1.67
1	56.9	2.18
1-1/8	71.5	2.71
1-1/4	87.9	3.43
1-3/8	106	4.25
1-1/2	125	5.01

7-FLEX WIRE ROPE

LiftPRO & MACWHYTE™ WIRE ROPE COMPANY

give you **7^{FLEX}** for longer, lower-cost wire rope service.

The seventh strand makes the difference!

7-FLEX Advantages:

- **FLEXIBILITY** of 8-strand wire rope!
- **FATIGUE RESISTANCE** of 6 x 37!
- **RUGGEDNESS** of 6 x 19!

RECOMMENDED USES:

LOGGING

Tractor Arch Lines, Tractor Winch or Drum Lines, Choker Ropes, Main Lines, Heel Boom Type Track Loader, Jammer and Tractor Drum Type Loader, Fall Line for Tight Skyline Decking and Loading, Sawmill Carriage Lines, Dozer Blade Hoist Rope and Grapple Crane Hoist Lines.

MINING AND CONTRACTING

Main Hoist Line, Combination Hoist and Crowd Lines, Inward and Outward Thrust Lines, Digging Line (Load Line), Bucket Hoist Line, Track Line, Tension Line, Bowl Lift Rope, Apron Rope, Ejector Rope, Shear Leg Line, Boom or Topping Lift Rope, Blade Lift Rope, Hoist or Fall Rope and Swing Rope, Wagon Scraper Hoist and Crowd Lines, Shovel Hoist Rope, Crowd and Retract Rope, Clamshell Holding and Closing Lines.

INDUSTRIAL

Overhead Hoists, Shop Hoists, Winch Lines, Material Hoists, Container Crane Trolley and Load Lines, Towing Hawsers, Car Pullers and Positioners, Skip Hoists, Slings.

OIL FIELD

Rotary Lines, Tubing Lines, Winch Lines and Casing Lines.

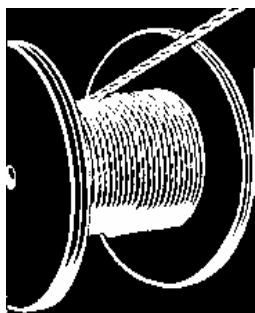

7-Flex wire rope spools evenly. It conforms to groove contours and hugs the drum.

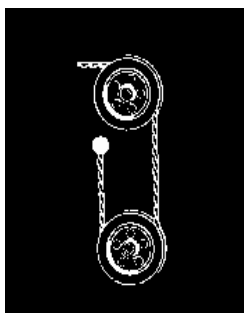

Bending stresses over sheaves are reduced, increasing service.

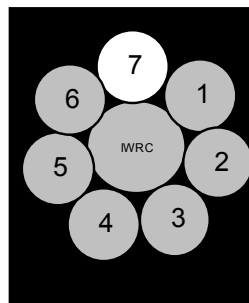

7-Flex is a true 7-strand wire rope—7-strands around an independent wire rope core. You get greater flexibility and easier handling.

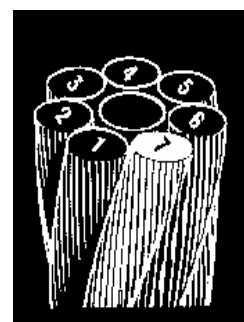

Seven strands give 7-Flex 16 2/3% more wearing surface than 6-strand wire rope.

7-FLEX WIRE ROPE

LiftPRO & MACWHYTE™ WIRE ROPE COMPANY

give you **7-FLEX** for longer, lower-cost wire rope service.

The seventh strand makes the difference!

7-FLEX with Plastic Filled Valleys:

PFV® WIRE ROPE—A thermoplastic material is extruded into a 7-FLEX lubricated wire rope. The finished rope has the strand valleys between strands and interstices equally filled with plastic, sealing the lubricant and assuring balanced rope.

STANDARD 7-FLEX WIRE ROPE WITH A PFV® WIRE ROPE CENTER—A thermoplastic material is extruded into only the wire rope center (IWRC). This is done in the same manner used in impregnating a finished rope. In this case, however, the outer rope strands are “closed” over the extruded wire rope center, and the appearance of the finished ropes is that of a conventional rope.

7-FLEX PLASTIC FILLED VALLEY WIRE ROPES AND PFV® IWRC ONLY in sizes up to and including 2-1/4” diameter.

FEATURES THAT MAKE PFV® WIRE ROPE WEAR RESISTANT:

- **PFVs REDUCE WIRE-CONTACT STRESS**—PFV Wire Rope provides load transfer and sharing between wires and strands unequaled by conventional wire rope. This promotes continued flexibility, and reduces interstrand nicking.
- **PFVs KEEP LUBRICATION INSIDE WIRE ROPE**—Macwhyte Plastic Filled Valley wire rope locks in lubrication to insure greater flexibility, increased endurance and improved wire rope life.
- **PFVs PROVIDE GREATER WEAR AREA**—compared to ordinary wire rope, PFV wire rope assures smoother wearing surfaces. Adapts to grooves and close tolerances. Minimizes bend stress over sheaves, increases fatigue life.
- **PFVs REDUCE INTERNAL ABRASION**—PFV Wire Rope’s plastic impregnation acts as a shield to prevent infiltration of solid abrasives, which could cause internal deterioration.

NOTICE: Published nominal strength apply only to new, unused wire rope. Any performance specifications are conditional on proper rope size, construction, and grade; on proper design and maintenance of mechanical equipment on which wire rope products are used; and on proper storage handling, use, maintenance and periodic inspection of such products during the period of use.

WARNING: Wire rope WILL FAIL if worn-out, overloaded, misused, damaged, improperly maintained or abused. Wire rope failure may cause serious injury or death! Protect yourself and others. **ALWAYS INSPECT** wire rope for **WEAR, DAMAGE or ABUSE BEFORE USE, NEVER USE** wire rope that is **WORN-OUT, DAMAGED, or ABUSED, NEVER OVERLOAD** a wire rope. **INFORM YOURSELF:** Read and understand manufacturer’s literature or “Wire Rope and Wire Rope Sling Safety Bulletin”** **REFER TO APPLICABLE CODES, STANDARDS and REGULATIONS for INSPECTION REQUIREMENTS and REMOVAL CRITERIA.***

**For additional information or the BULLETIN, ask your employer or wire rope supplier.*

7-FLEX IWRC with Plastic Filled Valley Wire Rope Center			
Rope Dia. In Inches	Rope Dia. In mm	Approx. Wt./Foot	Nominal Strength in Tons
1/2	12.7	13.10	.46
9/16	14.2	16.50	.59
5/8	15.8	20.30	.73
3/4	19.5	29.00	1.05
7/8	22.2	39.30	1.42
1	25.4	51.00	1.86
1-1/8	28.5	64.20	2.36
1-1/4	31.7	78.90	2.91
1-3/8	34.9	94.90	3.52
1-1/2	38.1	112.0	4.19
1-5/8	41.2	131.0	4.92
1-3/4	44.4	152.0	5.71
1-7/8	47.6	173.0	6.55
2	50.8	196.0	7.46
2-1/8	53.9	219.0	8.41
2-1/4	57.1	245.0	9.43

FLEX-X9 WIRE ROPE

LiftPRO & MACWHYTE™ WIRE ROPE COMPANY introduce FLEX-X 9 when drum crushing is a problem

Wire Rope Corporation of America, Incorporated announces the newest addition to the Flex-X family, Flex-X 9. Our research and field engineers have devoted a great deal of time and effort to design FLEX-X 9, the very latest in compacted wire rope.

Its high-density strands deliver extra strength, surprising bendability, a stubborn resistance to abrasion, and perhaps its greatest asset to users—a high resistance to drum crushing.

Beyond the design, Flex-X 9 is manufactured with a dual compaction process to produce a compact cross-section with minimum voids and greater surface area on outer wires that contact drums, sheaves and the rope, itself, during operation. This process also results in high-density, compacted strands to minimize nicking at strand-to-strand contact points.

FLEX-X 9 takes the guessing game out of rope inspection.

While compacted ropes may develop broken wires internally before they develop external broken wires, Flex-X 9's unique design decreases the nicking associated with internal wire breaks and makes external wire breaks the more likely mode of deterioration. This makes inspection easier for you. Just consider how valuable that benefit is to your operation.

Removal criteria are more stringent for difficult-to-see interior breaks than for breaks on the outside wires.

Reduce crushing and scrubbing damage on your wire rope.

FLEX-X 9's designers focused specifically on the challenges of multiple-layer spooling and inadequate tensioning of rope wraps on the drum, both of which contribute to crushing and scrubbing of wire rope.

At crossover points on the drum, the increased contact pressure can result in damage by distorting the cross-section shape of the rope, its strands or core—or all three. Ropes that are new or not spooled onto the drum under tension are particularly prone. Flex-X 9's compact design resists this pressure.

At kickover points on the drum, adjacent ropes slide against each other. Compared to standard 6 x 26 ropes, Flex-X 9's smooth contact creates less interference, metal loss and wire deformation.

*Sizes larger than listed available only in specific lengths and on request.

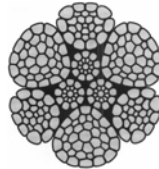

Flex-X 9 weights and minimum breaking force			
Rope Dia. in Inches	Rope Dia. In mm	Wt./Feet (pounds)	Min. Breaking Force (tons)
5/8	15.8	.95	26.2
3/4	19.5	1.35	37.4
7/8	22.2	1.85	50.6
1	25.4	2.40	65.7
1-1/8	28.5	3.05	82.7

NOTICE: Published nominal strength apply only to new, unused wire rope. Any performance specifications are conditional on proper rope size, construction, and grade; on proper design and maintenance of mechanical equipment on which wire rope products are used; and on proper storage handling, use, maintenance and periodic inspection of such products during the period of use.

FLEX-X9 versus standard 6 x 26 WS

Drum scrubbing between the lead line and the previous wrap is reduced. The smooth contact creates less interference, less metal loss and wire deformation.

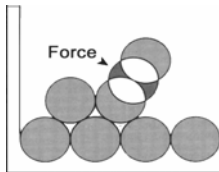

The increased surface area of Flex-X 9 can be seen in the comparison of contact points of a standard 6 x 26 WS (left) and Flex-X 9 (right).

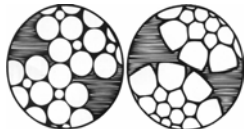

Contact forces are spread on sheave and drum grooves, wear is reduced and corrugation prevented.



WARNING: Wire rope WILL FAIL if worn-out, overloaded, misused, damaged, improperly maintained or abused. Wire rope failure may cause serious injury or death! Protect yourself and others. ALWAYS INSPECT wire rope for WEAR, DAMAGE or ABUSE BEFORE USE, NEVER USE wire rope that is WORN-OUT, DAMAGED, or ABUSED, NEVER OVERLOAD a wire rope. INFORM YOURSELF: Read & understand manufacturer's literature or "Wire Rope and Wire Rope Sling Safety Bulletin"*. REFER TO APPLICABLE CODES, STANDARDS & REGULATIONS for INSPECTION REQUIREMENTS & REMOVAL CRITERIA.*

*For additional information or the BULLETIN, ask your employer or wire rope supplier.

POWER FLEX-19 WIRE ROPE

LiftPRO by NESCO, Inc. gives you Power Flex 19™ Compacted Strand Rotation Resistant Rope

POWER FLEX 19 Advantages:

- **STRENGTH**
- **ROTATION RESISTANCE**
- **FATIGUE RESISTANCE**
- **ABRASION RESISTANCE AND DRUM CRUSHING**

Power Flex 19™ Provides:

- **STRENGTH**—Exceeds 6 x 19 EIP and 8 x 19 EIP. Over 30% stronger than 19 x 7 EIP rotation resistant rope.
- **ROTATION RESISTANCE**—The Power Flex 19 design provides excellent stability and rotation resistance for crane hoisting applications. Power Flex 19 has improved rotation resistance compared to conventional 8 x 19 and 19 x 7 ropes.
- **FATIGUE RESISTANCE**—The combination of flexible 19 wire strands and compacting give Power Flex 19 excellent fatigue resistance.
- **ABRASION RESISTANCE AND DRUM CRUSHING**—The smoother outer surface of the compacted strands minimizes scrubbing between layers during drum winding. Abrasion resistance is also improved due to the larger bearing surface of compacted strand.

Power Flex 19™ is a new development in multi-strand high strength, rotation resistant wire rope. The Power Flex 19 construction consists of 12 outer strands of 19 wires, layed contrahelically over 6 strands of 19 wires, and a 19 wire center strand. All strands are compacted following formation of the strand. Compacting creates a smooth outer surface on the strand and enables the rope to achieve a high breaking strength.

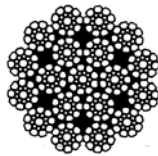

Power Flex 19™ is designed for use on single and multipart hoisting systems, where resistance to twisting or cabling is important.

Instructions for handling and use for Power Flex 19 Rotation Resistant Rope:

- To assure balance is maintained between inner and outer layers of this rope, at least three tight servings should be made on each side of a cut.
- Do not use swivels. The actual breaking strength of any rope is reduced if one end is free to rotate. This reduction can be as much as 50 percent.
- ANSI/ASME B30 standards require 5:1 design factor for rotation resistant rope.
- Do not use for slings, boom hoist lines or support pendants.
- Avoid sudden release of tension or shock unloading.

Follow manufacturers recommendations for installation of wedge sockets, wire rope clips or other end terminations.

Power Flex 19 Premium Whyte Strand IWRC			
Rope Dia. in Inches	Rope Dia. In mm	Approx. Wt./Foot	Nom. Strength in Tons
1/2	12.7	.50	14.6
9/16	14.2	.64	18.5
5/8	15.8	.79	22.7
3/4	19.5	1.15	32.3
7/8	22.2	1.50	43.8
1	25.4	2.00	56.9
1-1/8	28.5	2.50	71.5

NOTICE: Any performance specifications are conditional on proper rope size, construction, and grade; on proper design and maintenance of mechanical equipment on which wire rope products are used; and on proper storage, handling, use, maintenance and periodic inspection of such products during their period of use.

WARNING: Wire rope WILL FAIL if worn-out, overloaded, misused, damaged, improperly maintained or abused. Wire rope failure may cause serious injury or death! **ALWAYS INSPECT** wire rope for **WEAR, DAMAGE or ABUSE BEFORE USE. REFER TO APPLICABLE CODES, STANDARDS and REGULATIONS for INSPECTION REQUIREMENTS and REMOVAL CRITERIA. ALWAYS REPLACE** wire rope that is **WORN-OUT, DAMAGED or ABUSED. NEVER OVERLOAD** wire rope
*For additional information or the **BULLETIN**, ask your employer or wire rope supplier.

STARLIFT PLUS WIRE ROPE 35 x 7

LiftPRO & Casar give you Casar Starlift Plus Wire Rope

Casar Starlift Plus Advantages:

- FLEXIBILITY
- ABRASION RESISTANCE AND DRUM CRUSHING
- ROTATION RESISTANCE
- FATIGUE RESISTANCE
- STRENGTH

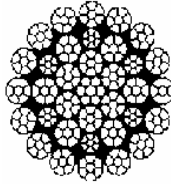

Casar Starlift Plus Provides:

- **FLEXIBILITY**—The Casar Starlift Plus unique 35 strand construction increases flexibility.
- **ABRASION RESISTANCE AND DRUM CRUSHING**—Round rope surface and compacted outer strands make Casar Starlift Plus very resistant against drum crushing.
- **ROTATION RESISTANCE**—19 strands in the IWRC counteract the torque of the 16 outer strands, making Casar starlift Plus extremely rotation resistant.
- **FATIGUE RESISTANCE**—The equal load distribution between inner and outer strands coupled with the round IWRC greatly reduces the danger of internal wire breaks.
- **STRENGTH**—Casar has a high breaking strength which is not reduced when the rope is used with a swivel.

Casar introduced the **Casar Starlift** in 1982 and it quickly became a very successful hoist rope for tower and mobile cranes. After years of development and testing, Casar introduced **Casar Starlift Plus** to the American market.

Casar Starlift Plus				
Rope Dia. in Inches	Rope Dia. In mm	Wt./Feet (pounds)	Min. Breaking Strength 1960 N/mm	
inches	mm	lbs/foot	Metric tons	Tons of 2000 lbs
3/8		0.291	8.37	9.22
	10	0.322	9.14	10.07
7/16	11	0.390	11.09	12.22
	12	0.479	13.34	14.70
1/2		0.518	14.87	16.39
	13	0.548	15.57	17.16
	14	0.631	18.26	20.12
	15	0.656	18.82	20.74
9/16		0.656	18.82	20.74
	16	0.732	20.80	22.92
5/8	17	0.827	23.51	25.91
	18	0.931	26.30	28.98
3/4	19	1.038	29.97	33.03
	20	1.150	33.55	36.97
	21	1.280	36.93	40.70
	22	1.406	40.39	44.51
7/8	23	1.532	45.01	49.60
	24	1.586	45.55	50.19
	25	1.683	48.11	53.02
	26	1.830	53.46	58.91
1	27	1.982	57.91	63.82
	28	2.072	59.49	65.56
	29	2.173	62.70	69.10
	30	2.332	66.71	73.51
	31	2.503	72.70	80.12
	32			

WIRE ROPE INSTALLATION AND HANDLING

Wire Rope Installation and Handling Recommendations PLEASE READ & UNDERSTAND BEFORE INSTALLING WIRE ROPE

Installation:

The initial installation of the rope to your equipment is most important. High performance wire ropes can be damaged from induced twist through Incorrect Installation. An extreme circumstance may mean discard of the rope.

The rope when installed to your equipment must be reeled correctly.

OVERWOUND DRUM: IF installing onto the top of your machinery drum the rope must be reeled from the top of the reel under a constant maintained tension.

UNDERWOUND DRUM: IF installing onto the bottom of your drum the rope must be reeled from the bottom of the reel with a constant maintained tension.

The rope should not be allowed to uncoil with loose wraps on the reel.

An easy way to remember the correct installation method is: **TOP TO TOP/ BOTTOM TO BOTTOM**

To not maintain a constant tension during Installation can induce twist into the rope and your reeving system, or worse, the rope could become kinked - possible rendering the product unsuitable for service.

Do not install the rope directly to the **rope** drum without tension being applied.

For tensioning, we recommend 1 to 1 1/2 % of the minimum-breaking load (mbl) of the rope.

35 ton mbl x 1 1/2% - approximately 1/2 ton tension required

80 ton mbl x 1 1/2% = 1.2 ton approximate tension required

Fleet Angle: To install with a greater than a 1 1/2° (degree) fleet angle, can induce excessive twist or rotation into the rope. Please be aware of the importance of correct alignment of the reel to sheave or drum for installation purposes. High performance rotation resistant ropes can be susceptible to problem from twist Induced at Installation -refer to the diagram below, the twist of a rope at 1» fleet angle and at 5°. Twist becomes induced due to the rope not entering the sheave etc at the lowest point, (that point being the sheave groove), first touching the flange then rolling into the bottom of the groove.

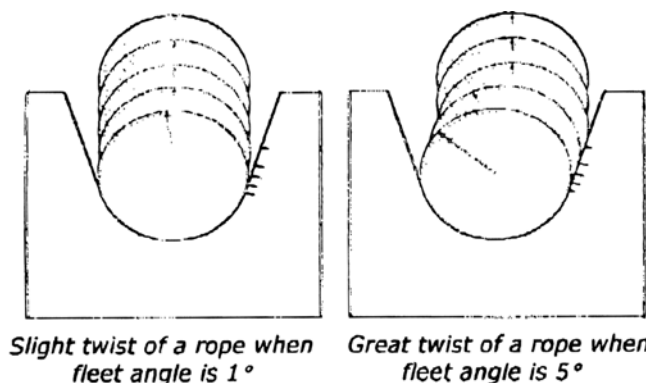

The rolling action caused by excessive fleet angle twists the rope. This negative effect is further accentuated when multi part reeving systems are used.

WIRE ROPE INSTALLATION AND HANDLING

Wire Rope Installation and Handling Recommendations PLEASE READ & UNDERSTAND BEFORE INSTALLING WIRE ROPE

Connection of New to Old Ropes:

When connecting your new rope to the old for Installation purposes - a wire rope stocking or Chinese finger should be used to allow any twist or spin to work itself out. Do not weld or damp directly the new to the old rope, otherwise you risk the possible transfer of twist or built up spin in the old rope being transferred to the new.

Your local wire rope distributor can supply you the correct equipment.



CHINESE FINGER OR ROPE STOCKING

Handling

Rotation Resistant Wire Ropes are non-preformed products - this means the rope will unwind or can cause loosening of the outer and inner wires, being detrimental to the performance of the rope, if the weld on each end of the rope is released. The ends must always remain welded while in service. (This may go against some old time practices, but with our ropes it is mandatory). Should for any reason the rope needs to be shortened - a suitable seizing can be applied to either side of the area to be cut. After cutting, the end of the rope must be re-welded to restrict movement of the wires. A suitable seizing is one long wire seizing of 3-4 rope diameters either side of the area to be cut - or 3 separate seizings each of 1 rope diameter. (Good quality screw adjustable radiator hose clamps can also be utilized with a suitable quantity and tension being applied). We suggest a minimum of 3 clamps, tightly tensioned, fitted either side of the cut to be made. Cutting should be by means of friction wheel - not flame cut. The weld on the end of the rope should be made where possible to form a point and not increase the rope diameter; otherwise a problem at the termination point may result.

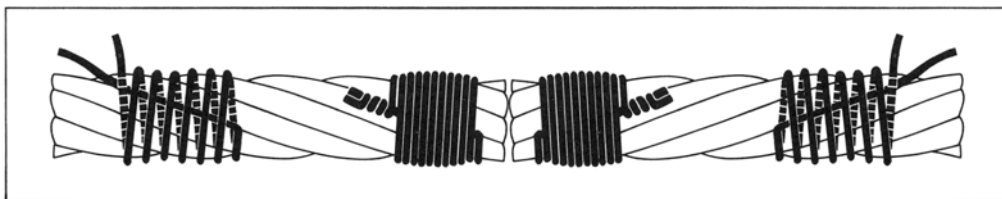

CORRECT SEIZING AND CUTTING METHOD

Breaking in the Rope:

Once installed, implement a couple of light lifting motions to allow the rope to settle and adjust before heavy load lifting is commenced.

CASAR STARLIFT AND CASAR EUROFT rotation resistant products can be operated with a swivel without any loss of safety. The use of a swivel is actually recommended. The above ropes are able to be operated either with or without a swivel in the reeving system.

SCREW PIN ANCHOR SHACKLES

Screw Pin Anchor Shackles

- RRC-271D Amend 1 Type IVA, Grade A, Class 2
- All shackles meet or exceed Federal Specification RRC-271
- Working Load Limit and traceability codes shown as permanent marking on body and pin
- Available in painted, galvanized and self-colored finishes (Dacromate coating upon special request only)
- All shackles have alloy quenched and tempered pins
- Shackles made from advanced microalloy material
- Load break tests consistently show microalloy outperforms quenched and tempered carbon material
- Shock load testing of assemblies at -300°F consistently demonstrate microalloy outperforms quenched and tempered carbon material
- Shackles exhibit extreme deformation before failure
- Special testing and certification including magnetic particle, proof load, fatigue test available by request at time of order
- Special engineering available to fit your special lifting, tie down, and pulling needs

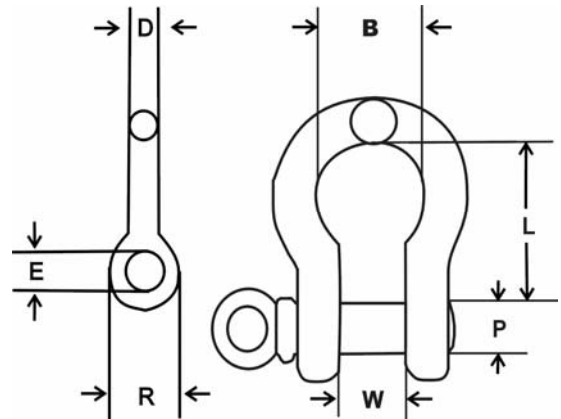

DIMENSIONS (INCHES)						
SIZE	Diameter of Pin	Diameter of Hole	Width between Eyes	Length Inside	Inside Width at Bow	Outside Diameter of Eye
D (nom)	P (nom)	E (ref)	W (nom)	L (nom)	B (min)	R (max)
3/16	0.250	0.307	0.375	0.875	0.562	0.625
1/4	0.312	0.401	0.469	1.125	0.750	0.875
5/16	0.375	0.463	0.531	1.250	0.812	1.000
3/8	0.438	0.531	0.656	1.437	0.937	1.125
7/16	0.500	0.593	0.750	1.689	1.062	1.250
1/2	0.625	0.718	0.813	1.875	1.187	1.375
5/8	0.750	0.843	1.063	2.375	1.500	1.875
3/4	0.875	0.968	1.250	2.813	1.750	2.125
7/8	1.000	1.109	1.438	3.312	2.000	2.375
1	1.125	1.234	1.688	3.750	2.312	2.625
1 1/8	1.250	1.375	1.812	4.250	2.625	2.875
1 1/4	1.375	1.531	2.031	4.688	2.875	3.250
1 3/8	1.500	1.656	2.250	5.250	3.250	3.500
1 1/2	1.625	1.781	2.375	5.750	3.375	3.750
1 5/8	1.750	1.906	2.625	6.250	4.000	4.125
1 3/4	2.000	2.156	2.875	7.000	4.500	4.500

DIMENSIONS (INCHES)					
Size	Working Load Limit WLL (tons)	Product Code	Painted UPC 43927-	Galvanized UPC 43927-	Approx Weight Each (lbs)
3/16	1/2	M645	-	40061	.06
1/4	3/4	M646	40070	40062	.12
5/16	1	M647	40008	40064	.20
3/8	1 1/2	M648	40012	40066	.30
7/16	2	M649	40016	40068	.50
1/2	3	M650	40020	40070	.75
5/8	4 1/2	M651	40023	40073	1.3
3/4	6 1/2	M652	40027	40074	2.3
7/8	8 1/2	M653	40031	40076	3.5
1	10	M654	40036	40077	5.0
1 1/8	12	M655	40039	40080	7.0
1 1/4	14	M656	40041	40082	9.5
1 3/8	17	M666	40044	40084	12.5
1 1/2	20	M657	40048	40087	17.2
1 5/8	24	M685	40052	40089	23.5
1 3/4	30	M677	40056	40091	27.7
2	35	M658	40060	40093	39.0

BOLT SAFETY ANCHOR SHACKLES

Bolt Safety Anchor Shackles

- RRC-271D Amend 1 Type IVA, Grade A, Class 3
- All shackles meet or exceed Federal Specification RRC-271D
- Working Load Limit and traceability codes shown as permanent marking on body and pin
- Available in painted, galvanized and self-colored finishes (Dacromate coating upon special request only)
- All shackles have alloy quenched and tempered pins
Shackles made from technically advanced microalloy material
- Load break tests consistently show microalloy outperforms quenched and tempered carbon material
- Shock load testing of assemblies at -300°F consistently demonstrate microalloy outperforms quenched and tempered carbon material
- Shackles exhibit extreme deformation before failure
- Special testing and certification including magnetic particle, proof load, fatigue test available by request at time of order
- Special products engineering available to fit your special lifting, tie down, and pulling needs

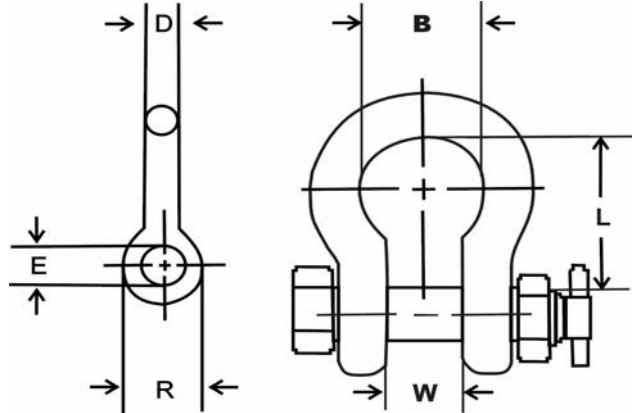

SIZES, CODES & SPECIFICATIONS					
Size	Working Load Limit WLL (tons)	Product Code	Painted UPC 43927-	Galvanized UPC 43927-	Approx Weight Each (lbs)
1/4	3/4	M846	40070	40062	.12
5/16	1	M847	40008	40064	.20
3/8	1 1/2	M848	40012	40066	.30
7/16	2	M849	40016	40068	.50
1/2	3	M850	40020	40070	.75
5/8	4 1/2	M851	40023	40073	1.3
3/4	6 1/2	M852	40027	40074	2.3
7/8	8 1/2	M853	40031	40076	3.5
1	10	M854	40036	40077	5.0
1 1/8	12	M855	40039	40080	7.0
1 1/4	14	M856	40041	40082	9.5
1 3/8	17	M866	40044	40084	12.5
1 1/2	20	M857	40048	40087	17.2
1 5/8	24	M885	40052	40089	23.5
1 3/4	30	M877	40056	40091	27.7
2	35	M858	40060	40093	39.0

DIMENSIONS (INCHES)						
SIZE	Diameter of Pin	Diameter of Hole	Width between Eyes	Length Inside	Inside Width at Bow	Outside Diameter of Eye
D (nom)	P (nom)	E (ref)	W (nom)	L (nom)	B (min)	R (max)
1/4	0.312	0.401	0.469	1.125	0.750	0.875
5/16	0.375	0.463	0.531	1.250	0.812	1.000
3/8	0.438	0.531	0.656	1.437	0.937	1.125
7/16	0.500	0.593	0.750	1.689	1.062	1.250
1/2	0.625	0.718	0.813	1.875	1.187	1.375
5/8	0.750	0.843	1.063	2.375	1.500	1.875
3/4	0.875	0.968	1.250	2.813	1.750	2.125
7/8	1.000	1.109	1.438	3.312	2.000	2.375
1	1.125	1.234	1.688	3.750	2.312	2.625
1 1/8	1.250	1.375	1.812	4.250	2.625	2.875
1 1/4	1.375	1.531	2.031	4.688	2.875	3.250
1 3/8	1.500	1.656	2.250	5.250	3.250	3.500
1 1/2	1.625	1.781	2.375	5.750	3.375	3.750
1 5/8	1.750	1.906	2.625	6.250	4.000	4.125
1 3/4	2.000	2.156	2.875	7.000	4.500	4.500
2	2.250	2.406	3.250	7.750	5.250	5.250

FIST GRIP CLIPS

Fist Grip Clips

TABLE 1
Dimensions in inches

If a pulley (sheave) is used for turning back the wire rope, add one additional clip.

If a greater number of clips are used than shown in the table, the amount of turnback should be increased proportionately.

The tightening torque values shown are based upon the threads being clean, dry, and free of lubrication.

Values do not apply to plastic coated wire ropes.

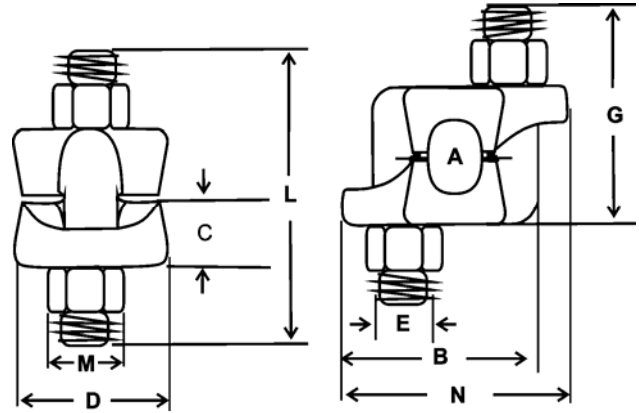

Clip Size Inches	Dimensions (in.)									Min. Number of Clips	Amount of Rope to Turn Back	Torque in Lbs. / Ft.	Weight Pounds / 100
	A	B	C	D	E	G	L Approx.	M	N				
3/16-1/4	.25	1.25	.34	.94	.38	1.28	1.63	.69	1.47	2	4	30	18
5/16	.31	1.34	.44	1.06	.38	1.47	1.94	.69	1.56	2	5	30	28
3/8	.38	1.59	.50	1.06	.44	1.81	2.38	.75	1.88	2	5-1/4	45	40
7/16	.50	1.88	.56	1.25	.50	2.19	2.75	.88	2.19	2	6-1/2	65	70
1/2	.50	1.88	.56	1.25	.50	2.19	2.75	.88	2.19	3	11	65	70
9/16	.63	2.28	.69	1.50	.63	2.69	3.50	1.06	2.63	3	12-3/4	130	100
5/8	.63	2.28	.69	1.50	.63	2.69	3.50	1.06	2.63	3	13-1/2	130	100
3/4	.75	2.69	.88	1.81	.75	2.94	3.75	1.25	3.06	3	16	225	175
7/8	.88	2.97	.97	2.13	.75	3.31	4.13	1.25	3.14	4	26	225	225
1	1.00	3.06	1.19	2.25	.75	3.72	4.63	1.25	3.53	5	37	225	300
1-1/8	1.13	3.44	1.28	2.38	.88	4.19	5.25	1.44	3.91	5	41	360	400
1-1/4	1.25	3.56	1.34	2.50	.88	4.25	5.25	1.44	4.03	6	55	360	400
1-3/8	1.50	4.13	1.56	3.00	1.00	5.56	7.00	1.63	4.66	6	62	500	700
1-1/2	1.50	4.13	1.56	3.00	1.00	5.56	7.00	1.63	4.66	7	78	500	700

WIRE ROPE CLIPS

Wire Rope Clips

TABLE 2
Dimensions in inches

If a pulley (sheave) is used for turning back the wire rope, add one additional clip. If a greater number of clips are used than shown in the table, the amount of turnback should be increased proportionately.

The tightening torque values shown are based upon the threads being clean, dry, and free of lubrication.

Values do not apply to plastic coated wire ropes.

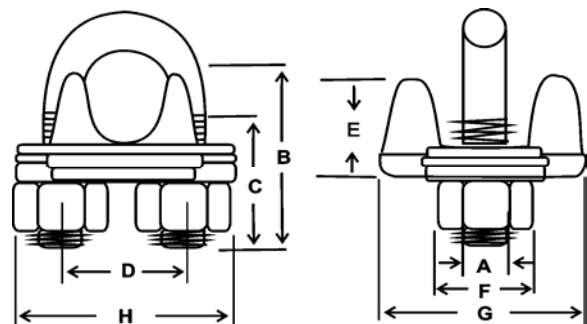

Clip Size Inches	Dimensions (in.)								Min. No. of Clips	Amount of Rope to Turn Back	Torque in		Weight Pounds / 100
	A	B	C	D	E	F	G	H			Lbs. / Ft.	Pounds	
1/8	.22	.72	.44	.47	.41	.38	.81	.94	2	3-1/4	4.5	6	
3/16	.25	.97	.56	.59	.50	.44	.94	1.16	2	3-3/4	7.5	10	
1/4	.31	1.03	.50	.75	.66	.56	1.19	1.44	2	4-3/4	15	20	
5/16	.38	1.38	.75	.88	.72	.69	1.31	1.69	2	5-1/4	30	30	
3/8	.44	1.50	.75	1.00	.91	.75	1.63	1.94	2	6-1/2	45	47	
7/16	.50	1.88	1.00	1.19	1.03	.88	1.81	2.28	2	7	65	76	
1/2	.50	1.88	1.00	1.19	1.13	.88	1.91	2.28	3	11-1/2	65	80	
9/16	.56	2.25	1.25	1.31	1.22	.94	2.06	2.50	3	12	95	104	
5/8	.56	2.38	1.25	1.31	1.34	.94	2.06	2.50	3	12	95	106	
3/4	.62	2.75	1.44	1.50	1.41	1.06	2.25	2.84	4	18	130	150	
7/8	.75	3.12	1.62	1.75	1.59	1.25	2.44	3.16	4	19	225	212	
1	.75	3.50	1.81	1.88	1.78	1.25	2.63	3.47	5	26	225	260	
1-1/8	.75	3.88	2.00	2.00	1.91	1.25	2.81	3.59	6	34	225	290	
1-1/4	.88	4.25	2.12	2.31	2.19	1.44	3.13	4.13	7	44	360	430	
1-3/8	.88	4.63	2.31	2.38	2.31	1.44	3.13	4.19	7	44	360	460	
1-1/2	.88	4.94	2.38	2.59	2.44	1.44	3.41	4.44	8	54	360	540	
1-5/8	1.00	5.31	2.62	2.75	2.66	1.63	3.63	4.75	8	58	430	700	
1-3/4	1.13	5.75	2.75	3.06	2.94	1.81	3.81	5.28	8	61	590	925	
2	1.25	6.44	3.00	3.38	3.28	2.00	4.44	5.88	8	71	750	1300	
2-1/4	1.25	7.13	3.19	3.88	3.19	2.00	4.50	6.38	8	73	750	1600	
2-1/2	1.25	7.69	3.44	4.13	3.69	2.00	4.05	6.63	9	84	750	1900	
2-3/4	1.25	8.31	3.56	4.38	4.88	2.00	5.00	6.88	10	100	750	2300	
3	1.50	9.19	3.88	4.75	4.69	2.38	5.88	7.63	10	106	1200	3100	
3-1/2	1.50	10.75	4.50	5.50	6.00	2.38	6.19	8.38	12	149	1200	4000	

SHEAVE WORKSHEET

Sheave Worksheet

- A. Outside Diameter: _____
- B. Thread Diameter: _____
- C. Hub Diameter: _____
- D. Outside Sheave Diameter _____
- E. Sheave Bore _____
- F. Radius _____ for
- G. _____ Diameter Rope

Recommended

Maximum Center Pin:

- H. Dimension for _____ Diameter
- I. (Nominal) _____ Diameter

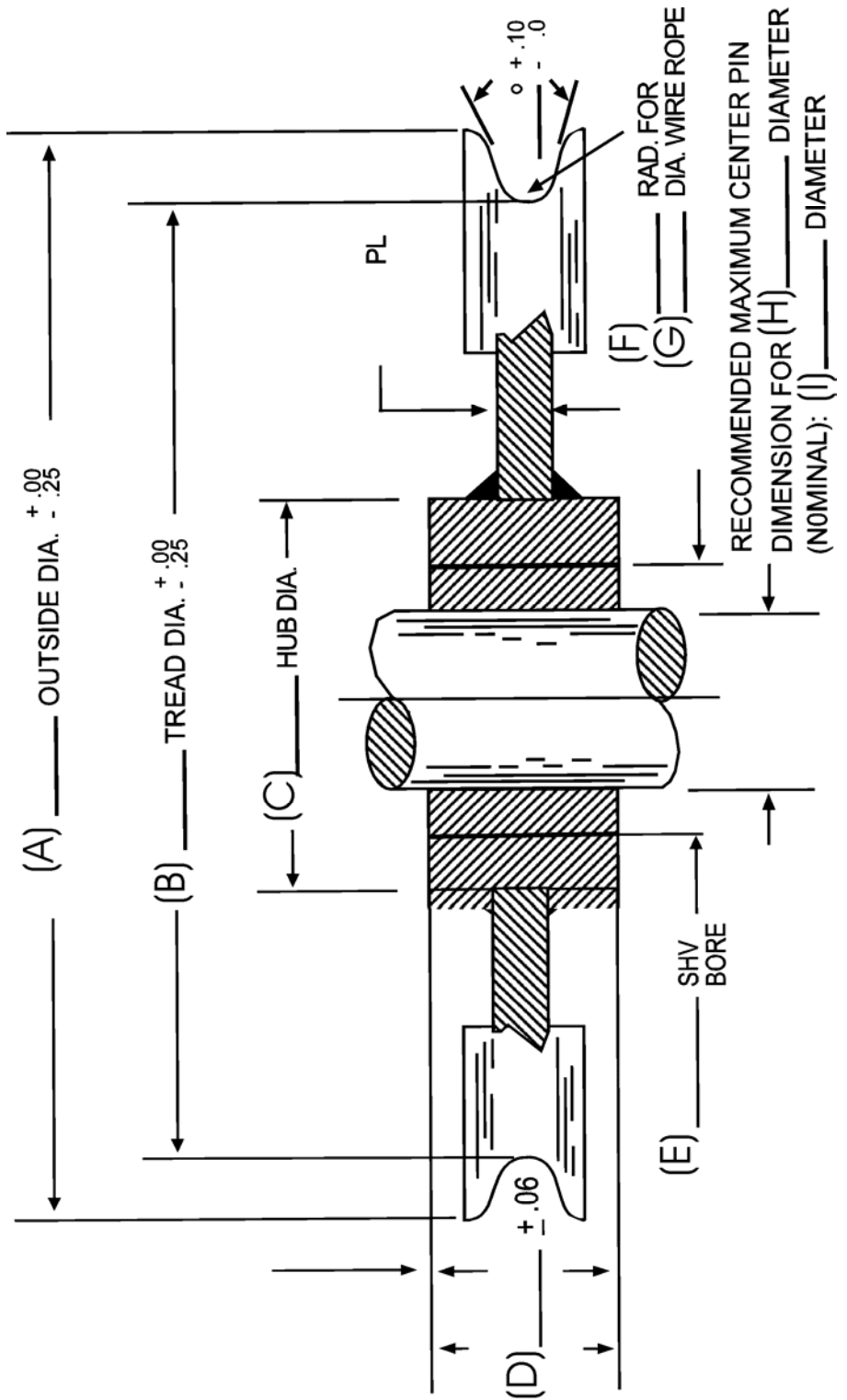

DIVIDED CRANE BLOCK WORKSHEET

Divided Crane Block Worksheet

Quantity: _____

Crane Information:

CMAA Rating: _____

Duty Cycle: _____

Environment: _____

Block Capacity (in tons) _____ WLL

Weight required _____ LBS.

Design Factor (min. 5 to 1):

Yes _____ Other _____

Wire Rope Diameter:

_____ Inches _____ Millimeters

Shear Information:

Number of Sheaves: _____

Outside Diameter: _____

Sheave center line to center line

Inner sheave _____

Outer sheave _____

Bearing Type:

Tapered _____ Straight _____ Bronze _____

Sheave Shroud: Yes _____ No _____

Sheave Groove Hardness Rc36 _____

Block Length: _____

Hook Information:

Hook Type:

Single Barbed _____ Duplex _____ Other _____

Hook throat opening, if critical _____

Type of Latch:

Material: Forged Steel _____

Cast Steel _____

Mill Duty: Yes _____ No _____ Hazardous

Duty: Yes _____ No _____

Locking Device: Yes _____ No _____

Is Dead End Required? Yes _____ No _____

Testing: Yes _____ No _____

Magnetic Particle _____ Ultrasonic _____

X-Ray _____

Other _____

Comments:

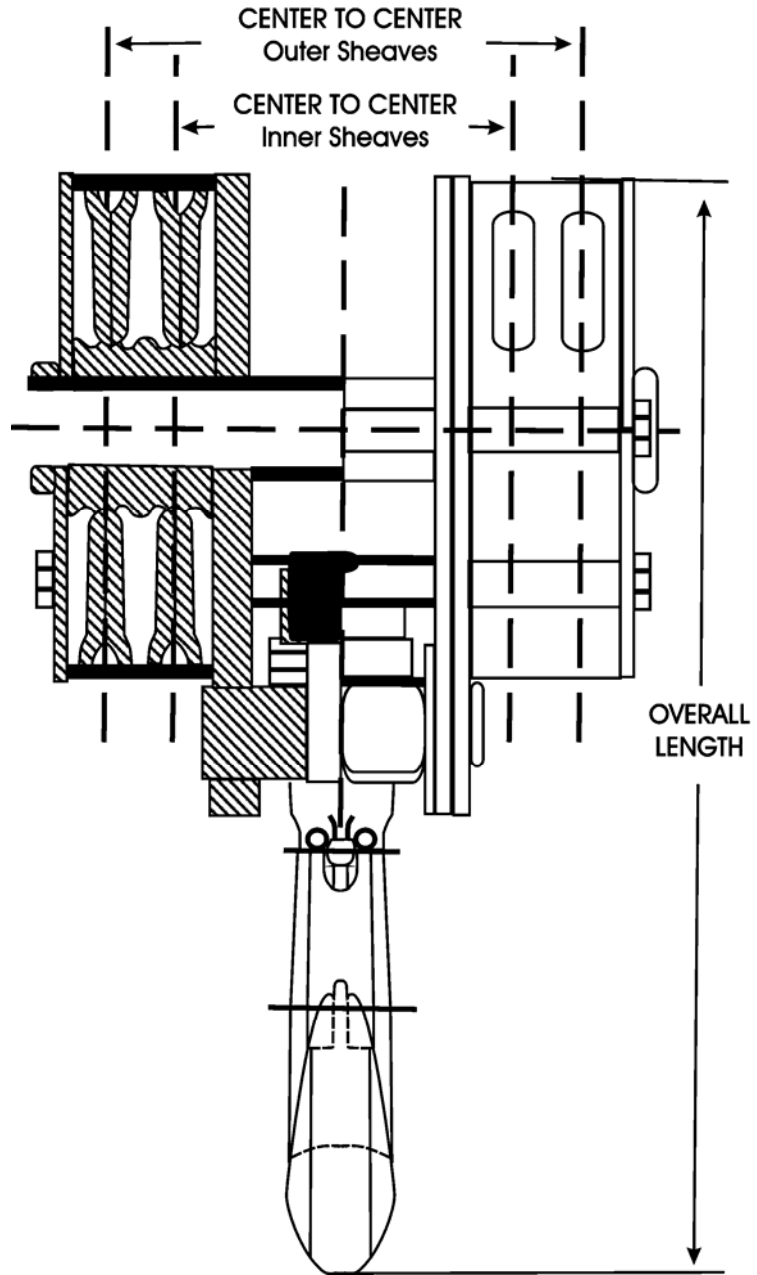

ALLOY SWIVEL EYE HOOKS

Alloy Swivel Eye Hooks

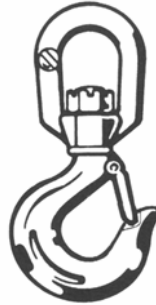

Alloy Swivel Hooks Without Latch																	
Hook Product Code	WLL (tons)	Weight (lbs.)	Dimensions (in.)														Latch Kit (Optional)
			A	B	C	D	E	F	G	H	I	L	R	S	T	O	
390-M3402A	1	1.05	2.00	1.11	1.25	3.06	.93	1.25	.87	1.00	.63	5.88	4.63	.38	.81	.88	4X1302
390-M3403A	1-1/2	1.56	2.50	1.38	1.50	3.33	.97	1.38	.94	1.11	.72	6.89	5.44	.50	.94	.94	4X1303
390-M3404A	2	2.50	3.00	1.65	1.75	3.67	1.06	1.50	1.06	1.21	.86	7.93	6.25	.63	1.00	1.00	4X1304
390-M3405A	3	3.20	3.00	1.65	1.75	4.20	1.19	1.63	1.27	1.43	.94	8.25	6.49	.63	1.19	1.13	4X1305
390-M3407A	5	5.36	3.50	1.77	2.00	5.11	1.50	2.00	1.44	1.62	1.15	9.72	7.53	.75	1.44	1.38	4X1307
390-M3409A	7	10.56	4.75	2.39	2.75	6.24	1.78	2.50	1.82	2.01	1.51	12.41	9.60	1.00	1.88	1.69	4X1309
390-M3411A	11	19.00	5.50	2.55	3.25	7.69	2.39	3.00	2.25	2.63	1.90	15.43	12.06	1.13	2.31	1.94	4X1311
390-M3415A	15	26.75	6.00	2.47	3.50	8.37	2.50	3.25	2.59	2.94	2.19	15.79	11.95	1.25	2.62	2.23	4X1315
390-M3422A	22	51.80	7.75	3.82	4.75	10.19	3.30	4.25	3.00	3.50	2.69	21.18	16.68	1.50	2.74	3.05	4X1322

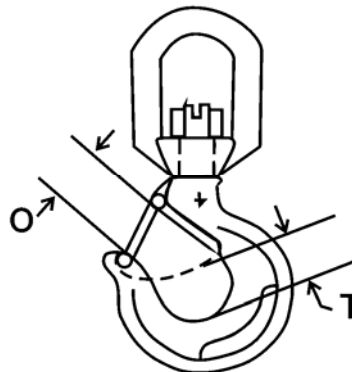
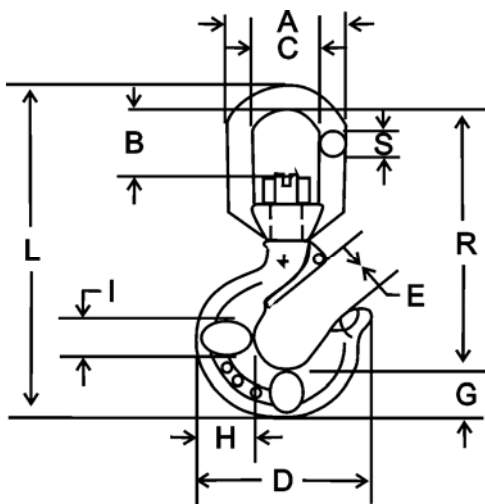

Alloy Swivel Hooks Assembled		
Hook Product Code	WLL (tons)	Weight (lbs.)
390-M3502A	1	1.5
390-M3503A	1-1/2	2.0
390-M3504A	2	3.0
390-M3505A	3	3.5
390-M3507A	5	7.5
390-M3509A	7	14.0
390-M3511A	11	16.02
390-M3515A	15	26.75
390-M3522A	22	51.80

CARBON AND ALLOY SWIVEL EYE HOOKS

Carbon and Alloy Swivel Eye Hooks

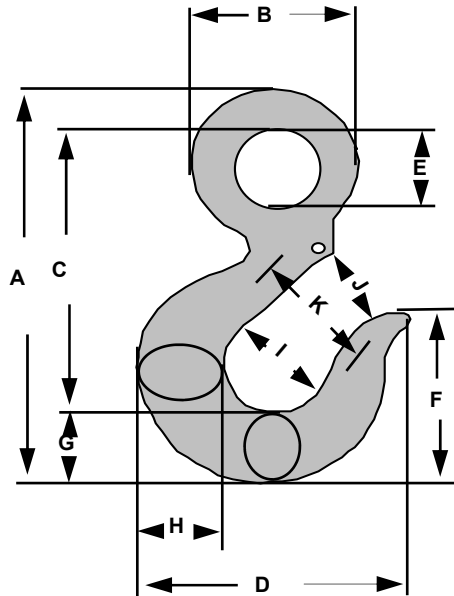

Working Load Limits (tons)		P/N Alloy W/ Latch	Weight (lbs.)	Dimensions (in.)											Deformation Indicator
Carbon	Alloy			A	B	C	D	E	F	G	H	I	J	K	
3/4	1	M6502A	.66	4.34	1.47	3.22	2.88	.75	2.00	.75	.81	1.25	.97	1.50	
1	1-1/2	M6503A	1.12	4.94	1.75	3.69	3.19	.91	2.25	.84	.94	1.38	1.06	1.50	
1-1/2	2	M6504A	1.46	5.56	2.03	4.09	3.62	1.13	2.53	1.00	1.16	1.50	1.12	2.00	
2	3	M6505A	2.42	6.38	2.41	4.69	4.09	1.25	2.84	1.12	1.31	1.63	1.25	2.00	
3	4-1/2	M6507A	4.10	7.91	2.94	5.78	4.94	1.56	3.56	1.44	1.62	2.00	1.50	2.50	
5	7	M6509A	8.16	10.09	3.81	7.38	6.50	2.00	4.44	1.18	2.06	2.50	1.88	3.00	
7-1/2	11	M6511A	15.60	12.44	4.69	9.06	7.56	2.44	5.50	2.25	2.62	3.00	2.25	4.00	
10	15	M65015A	21.58	13.94	5.38	10.06	8.69	2.84	6.19	2.59	2.94	3.25	2.50	4.00	
15	22	M65022A	39.89	17.09	6.63	12.53	11.00	3.50	7.31	2.97	3.50	4.25	3.38	5.00	

*Shank Hooks only.

WIRE ROPE DESIGN

Wire Rope Design

Design Factors:

The *design factor* is defined as the ratio of the nominal strength of a wire rope to the total load it is expected to carry. Hence, the design factor that is selected plays an important part in determining the rope's service life. Excessive loading, whether continuous or sporadic, will greatly impair its serviceability. Usually, the choice of a certain wire rope size and grade will be based on static loading and, under static conditions, it is sufficient for its talk. However, where a machine is working and dynamic loads are added to the static load, it is quite possible to exceed the material's elastic limit.

A "common" *design factor* is 5. Service life is reduced as operating loads are increased. A change in the *design factor* from 5 to 3 decreases its life expectancy index from 100 to 60—a drop of 40%.

Breaking Strengths:

The *breaking strength* is the ultimate load registered on a wire rope sample during a tension test.

The *nominal strengths* (see tables beginning at right) have been calculated by a consensus, industry-accepted procedure and manufacturers design wire rope to these strengths. When making design calculations, it should be noted that the given figures are the *static strengths*. Designers should base their calculations on these strengths.

A *minimum acceptance strength* 2-1/2% lower than the published nominal breaking strengths, was established as the industry tolerance. It serves to offset variables that occur during the sample preparation and actual physical test of a wire rope. This tolerance is used in the basic wire rope governmental specifications.

Wire rope testing, whether it is performed for the purpose of determining grade or for adherence to specifications, requires the sample to be tested to comply with certain standards. For example: the sample's length must not be less than 3 ft. (0.91m) between sockets for ropes with diameters of from 1/8 inch (3.2 mm) through 3 inches (77 mm); on ropes with larger (over 3 inches) diameters, the clear length must be at least 20 times the rope diameter. The test is considered valid only if failure occurs 2 inches (51mm) or more from either of the sockets, or from the holding mechanism. The speed of separation between the testing machine heads as the tension is applied and increased shall not be greater than one inch per minute.

Wire Rope Users Manual

Third Edition

Copyright , © 1993

Wire Rope Technical Board

P.O. Box 286

Woodstock, Maryland 21163-0286

NOTE:

LiftPRO by NESCO, INC.

assumes no responsibility for the misuse or misapplication of any of its products. Products are provided with the express understanding that the purchaser and/or user are thoroughly familiar with the correct application and proper use. Warnings and definitions are provided as an aid to the user in understanding correct application and proper use. These charts are not a substitute to proper training.

WIRE ROPE STRENGTHS AND WEIGHTS

Wire Rope Strengths and Weights—6x19 and 6x36 Classification/Bright (Uncoated)

Diameter		Approx. Mass		Minimum Breaking Force					
inches	mm	lb/ft	kg/m	IPS tons	1770 kN	EIP tons	1960 kN	EEIP tons	2160 kN
	6	0.10	0.153		22.7		2.51		27.7
1/4		0.12	0.172	2.94		3.40			
	7	0.14	0.209		30.9		34.2		37.7
5/16		0.18	0.268	4.58		5.27			
	8	0.18	0.273		40.3		44.7		49.2
	9	0.23	0.345		51.0		56.5		62.3
3/8		0.26	0.386	6.56		7.55		8.30	
	10	0.29	0.426		63.0		69.8		76.9
	11	0.35	0.515		76.2		84.4		93.0
7/16		0.35	0.526	8.89		10.20		11.20	
	12	0.41	0.613		90.7		100.5		110.7
1/2		0.46	0.687	11.5		13.3		14.6	
	13	0.48	0.720		106.5		117.9		130.0
	14	0.56	0.835		124		137		151
9/16		0.58	0.870	14.5		16.8		18.5	
5/8		0.72	1.074	17.7		20.6		22.7	
	16	0.73	1.091		161		179		197
	18	0.93	1.380		204		226		249
	19	1.03	1.538		227		252		278
3/4		1.04	1.546	25.6		29.4		32.4	
	20	1.15	1.704		252		279		308
	22	1.39	2.062		305		338		372
7/8		1.41	2.104	34.6		39.8		43.8	
	24	1.65	2.454		363		402		443
1		1.85	2.748	44.9		51.7		56.9	
	26	1.94	2.880		426		472		520
	28	2.24	3.340		494		547		603
1-1/8		2.34	3.478	56.5		65.0		71.5	
1-1/4		2.89	4.294	69.4		79.9		87.9	
	32	2.93	4.362		645		715		787
1-3/8		3.49	5.196	83.5		96.0		106.0	
	36	3.71	5.521		817		904		997

* To convert to Kilonewtons (kN), multiply tons by 8.896; 1 lb = 4.448 newtons (N)

** Available with galvanized wires at strengths 10% lower than listed, or at equivalent strength on special request.

Note: For four of the listed diameters, 1/4" through 7/16" with two-operation strands, the given strengths will be reduced by approximately 5-1/2%

WIRE ROPE STRENGTHS AND WEIGHTS

Wire Rope Strengths and Weights—6x19 and 6x36 Classification/Bright (Uncoated)

Diameter		Approx. Mass		Minimum Breaking Force					
inches	mm	lb/ft	kg/m	IPS tons	1770 kN	EIP tons	1960 kN	EEIP tons	2160 kN
1-1/2		4.16	6.184	98.9		114		125	
	40	4.58	6.816		1008		1116		1230
1-5/8		4.88	7.257	115		132		146	
	44	5.54	8.247		1220		1351		1489
1-3/4		5.66	8.417	133		153		169	
1-7/8		6.49	9.662	152		174		192	
	48	6.60	9.815		1452		1608		1772
2		7.39	10.994	172		198		217	
	52	7.74	11.519		1704		1887		2079
2-1/8		8.34	12.411	192		221		243	
	56	8.98	13.359		1976		2188		2411
2-1/4		9.35	13.914	215		247		272	
	60	10.31	15.336		2268		2512		2768
2-3/8		10.4	15.5	239		274		301	
2-1/2		11.6	17.3	262		302		332	
	64	11.6	17.3		2580		2860		3140
2-5/8		12.8	19.0	288		331		364	
	68	12.9	19.2		2910		3220		3550
2-3/4		14.0	20.8	314		361		397	
	72	14.5	21.5		3260		3610		3970
2-7/8		15.3	22.8	341		392		431	
	76	16.2	24.0		3630		4020		4430
3		16.6	24.7	370		425		468	
3-1/8		18.0	26.8	399		458		504	
	80	18.0	26.8		4040		4480		4930
3-1/4		19.5	29.0	429		492		541	
	84	19.7	29.3		4450		4930		5430
3-3/8		21.0	31.3	459		529		582	
	88	21.6	32.1		4880		5410		5950
3-1/2		22.7	33.8	491		564		620	

* To convert to Kilonewtons (kN), multiply tons by 8.896; 1 lb = 4.448 newtons (N)

** Available with galvanized wires at strengths 10% lower than listed, or at equivalent strength on special request.

Note: For four of the listed diameters, 1/4" through 7/16" with two-operation strands, the given strengths will be reduced by approximately 5-1/2%

WIRE ROPE NOMINAL STRENGTHS

Nominal Strengths of Wire Rope

7 x 7 and 7 x 19 Small Diameter Specialty Cord, Galvanized and Corrosion Resistant

Nominal Diameter		Nominal Strength*															
		Approximate Mass				Galvanized				Type 300 Corrosion Resistant				Type 316 Corrosion Resistant			
		7 x 7		7 x 19		7 x 7		7 x 19		7 x 7		7 x 19		7 x 7		7 x 19	
inches	mm	lbs./100f	kg/30.5	lbs./100f	kg/30.5	lb	kg	lb	kg	lb	kg	lb	kg	lb	kg	lb	kg
1/32	.794	.16*	.07*			110*	49.9*			110*	49.9*						
3/64	1.19	.42	.19			270	122			270	122						
1/16	1.59	.75	.34	.75	.34	480	218	480	218	480	218	480	218	480			
5/64	1.98	1.1	.50			650	295			650	295						
3/32	2.38	1.6	.73	1.7	.77	920	417	1000	454	920	417	920	417	920			
7/64	2.78	2.2	1.0			1260	572			1260	572						
1/8	3.18	2.8	1.3	2.9	1.3	1700	771	2000	907	1700	771	1760	798	1760		1760	
5/32	3.97	4.3	2.0	4.5	2.0	2600	1179	2800	1270	2400	1089	2400	108				
3/16	4.76	6.2	2.8	6.5	2.9	3700	1678	4200	1905	3700	1678	3700	167	3700		3700	
7/32	5.56	8.3	3.8	8.6	3.9	4800	2177	5600	2540	4800	2177	5000	226				
1/4	6.35	10.6	4.8	11.0	5.0	6100	2767	7000	3175	6100	2767	6400	290			6400	
9/32	7.14	13.4	6.1	13.9	6.3	7600	3447	8000	3629	7600	3447	7800	353				
5/16	7.94	16.7	7.6	17.3	7.8	9200	4173	9800	4445	9000	4082	9000	408			9000	
11/32	8.73	20.1	9.1	20.7	9.4	11100	5035	12500	5670	10500	4763						
3/8	9.52	23.6	10.7	24.3	11.0	13100	5942	14400	6532	12000	5443	12000	544			1200	

* 3 x 7 construction

** 30.5m = 100 ft.

***To convert to Kilonewtons (kN), multiply tons (nominal strength) by 8.896; 1 lb = 4.448 newtons (N).

WIRE ROPE NOMINAL STRENGTHS

Nominal Strengths of Wire Rope

8 x 19 Classification/Rotation Resistant/Bright (Uncoated), IWRC

Nom. Diameter		Approx. Mass		Nominal Strength*			
				Improved Plow Steel**		Extra Improved Plow Steel**	
inches	mm	lb/ft	kg/m	tons	met ton	tons	met ton
1/2	13	0.47	0.70	10.1	9.16	11.6	10.5
9/16	14.5	0.60	0.89	12.8	11.6	14.7	13.3
5/8	16	0.73	1.09	15.7	14.2	18.1	16.4
3/4	19	1.06	1.58	22.5	20.4	25.9	23.5
7/8	22	1.44	2.14	30.5	27.7	35.0	31.8
1	26	1.88	2.80	39.6	35.9	45.5	41.3
1-1/8	29	2.39	3.56	49.8	45.2	57.3	51.7
1-1/4	32	2.94	4.37	61.3	55.6	70.5	64.0
1-3/8	35	3.56	5.30	73.8	67.0	84.9	77.0
1-1/2	38	4.24	6.31	87.3	79.2	100.0	90.7
1/2	13	0.45	0.67	9.85	8.94	10.8	9.8
9/16	14.5	0.58	0.86	12.4	11.2	13.6	12.3
5/8	16	0.71	1.06	15.3	13.9	16.8	15.2
3/4	19	1.02	1.52	21.8	19.8	24.0	21.8
7/8	22	1.39	2.07	29.5	26.8	32.5	29.5
1	26	1.82	2.71	38.3	34.7	42.2	38.3
1-1/8	29	2.30	3.42	48.2	43.7	53.1	48.2
1-1/4	32	2.84	4.23	59.2	53.7	65.1	59.1
1-3/8	35	3.43	5.10	71.3	64.7	78.4	71.1
1-1/2	38	4.08	6.07	84.4	76.6	92.8	84.2

* To convert to Kilonewtons (kN), multiply tons (nominal strength) by 8.896; 1 lb. = 4.448 newtons (N).

** Available with galvanized wires at strengths 10% lower than listed, or at equivalent strengths on special request.

The given strengths are applicable only when a test is conducted on a new rope fixed at both ends. When the rope is in use, the breaking strength is reduced when one end is free to rotate.

The given strengths for 8 x 19 rotation resistant ropes are applicable only when a test is conducted on a new rope fixed at both ends. When the ropes is in use, and one end is free to rotate, the nominal strength is reduced.

WIRE ROPE SLINGS, CALCULATING LOADS

Wire Rope Slings

Horizontal Angle Between Legs of a Sling

Calculating the Load on Each Leg of a Sling:

As the horizontal angle between the legs of a sling and the load decreases, the load on each leg increases. The effect is the same whether a single sling is used as a basket, or two slings are used with each in a straight pull, as with a 2-legged bridle.

Anytime pull is exerted at an angle on a leg—or legs—of a sling, the load per leg can be determined by using the data in the table below. Proceed as follows to calculate this load—and determine the rated capacity required of the sling, or slings, needed for a lift:

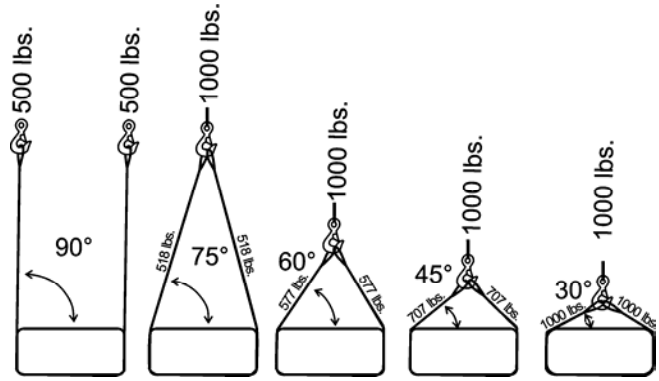

- First, divide load to be lifted by number of legs to be used. This provides load per leg if the lift were being made with all legs lifting vertically.
- Determine angle between legs of sling and the horizontal.
- Then MULTIPLY load per leg (as computed in No. 1 above) by the Load Factor for leg angle being used (from the table below)—to compute the ACTUAL load on each leg for this lift and angle. THE ACTUAL LOAD MUST NOT EXCEED THE RATED SLING CAPACITY.

Thus, in drawing three (sling angle at 60°): $1000 \div 2 = 500$ (load Per Leg if a vertical lift) $500 \times 1.154 =$ ACTUAL LOAD on each leg at the 60° included angle being used.

In drawing four (sling angle of 45°): $1000 \div 2 = 500$ (Load Per Leg if a vertical lift) $500 \div 1.414 = 707$ lbs. = ACTUAL LOAD on each leg at the 45° horizontal angle being used.

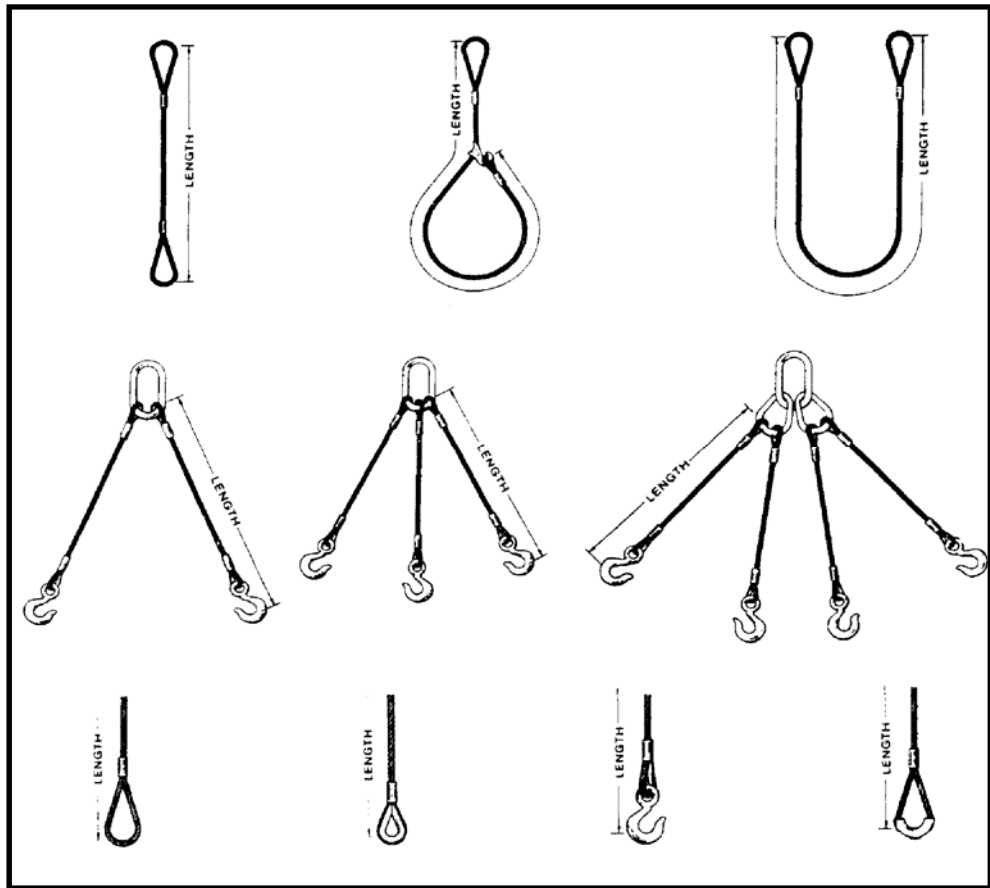

WIRE ROPE SLINGS, CALCULATING LOADS

Wire Rope Slings

Choker Hitch Rated Capacity Adjustment:

If a load is hanging free, the normal choke angle is approximately 135°. When the angle is less than 135° an adjustment in the sling rated capacity must be made. Choker hitches at angles greater than 135° are not recommended since they are unstable. Extreme care should be taken to determine the angle of choke as accurately as possible.

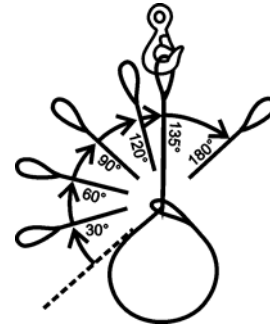

In controlled tests, where the angle was less than 120°, the sling body always failed at the point of choke when pulled to destruction. Allowance for this phenomenon must be made anytime a choker hitch is used to shift, turn or control a load, or when the pull is against the choke in a multi-leg lift.

Use the table to the right for wire rope slings in choker hitch when angle of choke is less than 120°.

Angle of choke in Degrees	Rated Capacity %*
OVER 120	100
90-120	87
60-89	74
30-59	62
0-29	49

Angles of Bridles:

The horizontal angle of bridles with 3 or more legs is measured the same as the horizontal sling angle of 2-legged hitches. In this case, where a bridle designed with different leg lengths results in different horizontal angles, the leg with the smallest horizontal angle will carry the greatest load. Therefore, the smallest horizontal angle is used in calculating actual leg load and evaluating the rated capacity of the sling proposed.

1. First, divide the load to be lifted by the number of legs to be used. This provides the load per leg if the lift were being made with all legs lifting vertically.
2. Determine the angle between the legs of the sling and the horizontal.
3. Then MULTIPLY the load per leg (as computed in No. 1 above) by the Load Factor for the leg angle being used (from the table below) —to compute the ACTUAL load on each leg for this lift and angle. THE ACTUAL LOAD MUST NOT EXCEED THE RATED SLING CAPACITY.

Angles of Bridles

LEG ANGLE (Degrees)	LOAD FACTOR
90	1,000
85	1,003
80	1,015
75	1,035
70	1,064
65	1,103
60	1,154
55	1,220
50	1,305
45	1,414
40	1,555
35	1,743
30	2,000

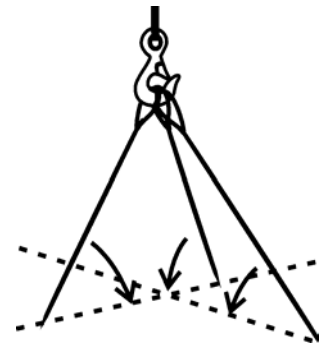

Sling Eye Design:

Sling eyes are designed to provide what amount to “small inverted slings” at the end of the sling body. Therefore, the width of the eye opening will be affected by the same general forces which apply to legs of a sling rigged as a basket. A sling eye should never be used over a hook or pin with a body diameter larger than the natural width of the eye. Never force an eye onto a hook. On the other hand, the eye should always be used on a hook or pin with at least the nominal diameter of the rope—since applying the D/d Ratio shows an efficiency loss of approximate 50% when the relationship is less than 1/1.

Sling Eye Design



WIRE ROPE INSPECTION CRITERIA

Basic Inspection Criteria For Wire Rope Slings

The goal of a sling inspection is to evaluate remaining strength in a sling which has been used previously to determine if it is suitable for continued use.

Specific inspection intervals and procedures are required by the Occupational Safety and Health Act (OSHA) and by ANSI B30.9c-2000 Regulations, and the responsibility for performance of inspections is placed squarely upon the sling user by Federal Legislation.

As a starting point, the same work practices which apply to all "working" wire ropes apply to wire rope which has been fabricated into a sling. Therefore, a good working knowledge of wire rope design and construction will be not only useful but essential in conducting a wire rope sling inspection.

But because wire rope is a rather complex machine, no precise rules can be given to determine exactly when a wire rope sling should be replaced. There are many variables, and all must be considered.

OSHA specifies that a wire rope sling shall be removed from service immediately if ANY of the following conditions are present:

9.2.8.3 Replacement

- (a) No precise rules can be given for determination of the exact time for sling replacement, since many variable factors are involved. Once a sling reaches a specified removal criteria, it may be allowed to operate to the end of the work shift, based on the judgment of a qualified person. The sling shall be replaced after that work shift, at the end of the day, or at the latest time prior to the next work shift.
- (b) Removal criteria for sling replacement shall be as follows:
 - (1) Missing or illegible sling identification (see Section 9-2.5 of ASME B30.9c-2000 ADDENDA to ASME B30.9-1996 SLINGS);
 - (2) for strand laid and single part slings ten randomly distributed broken wires in one rope lay, or five broken wires in one stand in one rope lay;
 - (3) severe localized abrasion or scraping;
 - (4) kinking, crushing, birdcaging, or any other damage resulting in distortion of the rope structure;
 - (5) evidence of heat damage;
 - (6) end attachments that are cracked, deformed or worn to the extent that the strength of the sling is substantially affected;
 - (7) hooks should be inspected in accordance with ASME B30.10;
 - (8) severe corrosion of the rope or end attachments;
 - (9) multipart removal criteria for cable laid and braided slings.

Allowable Broken Wires, Length

Sling Body	Per Lay	
	Per Lay	Per Braid
Cable Laid		20
Less than 8 part Braid		20
8 part braid and more		40

Disposition of Retired Slings: the best inspection program available is of no value if slings which are worn out and have been retired are not disposed of properly. When it is determined by the inspector that a sling is worn out or damaged beyond use, it should be tagged immediately **DO NOT USE**. This sling should then be destroyed as soon as possible by cutting the eye and fittings from the rope with a torch. This will help assure that an employee will not mistakenly use a sling which has been retired from service.

It should also be obvious that a good inspection program will not only provide safer lifting conditions, but will also extend the life of slings and thereby reduce lifting costs.

Federal Work Rules Require Specific Inspection Intervals

Government regulations are also specific on WHEN to inspect.

Both ANSI Standard B30.9 and OSHA require that wire rope slings receive two types of inspections: a DAILY visual inspection, and additional inspections where service conditions warrant.

Daily visual inspections are intended to detect serious damage or deterioration which would weaken the sling. This inspection is usually performed by the person using the sling in a day-to-day job. He should look for obvious things, such as broken wires, kinks, crushing, broken attachments, severe corrosion, etc.

Additional inspections should be performed at regular intervals based on, (1) frequency of sling use, (2) severity of service conditions, (3) nature of lifts, and (4) prior experience based on service life of slings used in similar circumstances.

It is required that these additional inspections be carried out by a designated person who must have good knowledge of wire rope. An accurate WRITTEN and dated record of all conditions observed should be kept. Any deterioration of the sling which could result in appreciable loss of original strength should be carefully noted, and determination made on whether further use would constitute a safety hazard.

How to Inspect

Precisely how to make proper, adequate inspections is not detailed by OSHA—yet it is in the HOW of inspection that the big difference between a good inspection and something less become apparent. Inspection should follow a systematic procedure:

1. It is necessary that all parts of the sling are readily visible. The sling should be laid out so every part is accessible.
2. Next, the sling should be sufficiently cleaned of dirt and grease so wires and fittings are easily seen. This can usually be accomplished with a wire brush or rags.
3. The sling should then be given a thorough, systematic examination throughout its entire length, paying particular attention to sections showing the most wear.
4. Special attention should also be paid to fittings and end attachments, and the areas of the sling that are adjacent to these fittings.
5. When the worst section of a sling has been located, this area should then be carefully checked against the OSHA criteria.
6. Label or identify slings that are inspected.
7. Keep records of inspections that include dates and corresponding conditions of slings.
8. Dispose immediately of slings that are rejected.

A knowledgeable inspector will also insist on proper storage for out-of-use slings—to make his job easier if not for the good of the slings. Inspections are much easier—and probably more thorough—when slings are available for inspection in an orderly arrangement, out of the weather, away from heat and dirt.

Wire Rope Sling Users Manual, ©1990
WIRE ROPE TECHNICAL BOARD
P. O. Box 849
Stevensville, Maryland 21666

NOTE:

LiftPRO by NESCO, INC.

assumes no responsibility for the misuse or misapplication of any of its products. Products are provided with the express understanding that the purchaser and/or user are thoroughly familiar with the correct application and proper use. Warnings and definitions are provided as an aid to the user in understanding correct application and proper use. These charts are not a substitute for proper training.

MECHANICAL SPLICE SLINGS—IMPROV. PLOW STEEL

Mechanical Splice Slings Improved Plow Steel

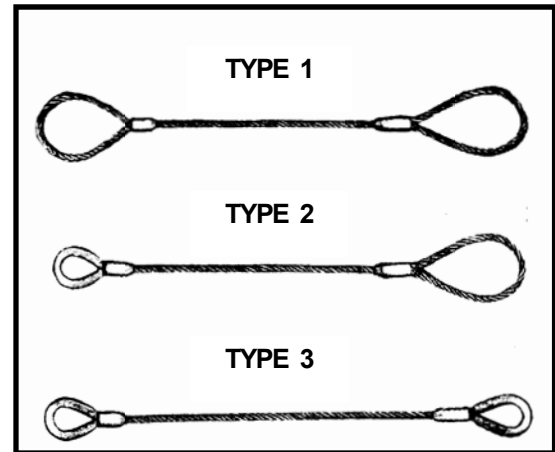
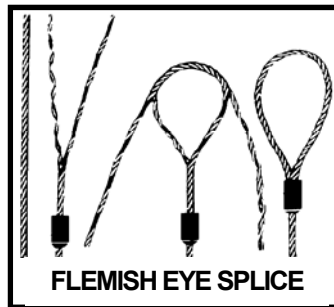

Mechanical Splice Slings - Improved Plow Steel								
Rope Dia. (In.)	Vertical	Choker	Vertical Basket	Type 1	Type 3	Standard Eye Size	Thimbled Eye Size (In.) W x L	Eye Hook Capacity (Tons)
1/4	0.56	0.41	1.1	1' - 1"	0' - 9"	2 x 4	7/8 x 1 5/8	1
5/16	0.87	0.64	1.7	1' - 4"	0' - 11"	2 1/2 x 5	1 1/16 x 1 7/8	1
3/8	1.2	0.92	2.5	1' - 8"	1' - 1"	3 x 6	1 1/8 x 2 1/8	1 1/2
7/16	1.7	1.2	3.4	1' - 11"	1' - 3"	3 1/2 x 7	1 1/4 x 2 1/4	2
1/2	2.2	1.6	4.4	2' - 2"	1' - 4"	4 x 8	1 1/2 x 2 3/4	3
9/16	2.8	2.0	5.5	2' - 5"	1' - 5"	4 1/2 x 9	1 1/2 x 2 3/4	4 1/2
5/8	3.4	2.5	6.8	2' - 9"	1' - 8"	5 x 10	1 3/4 x 3 1/4	4 1/2
3/4	4.9	3.6	9.7	3' - 3"	1' - 11"	6 x 12	2 x 3 3/4	7
7/8	6.6	4.8	13	3' - 10"	2' - 3"	7 x 14	2 1/4 x 4 1/4	11
1	8.5	6.3	17	4' - 4"	2' - 6"	8 x 16	2 1/2 x 4 1/2	11
1 1/8	10	7.9	21	4' - 11"	2' - 10"	9 x 18	2 7/8 x 5 1/8	15
1 1/4	13	9.7	26	5' - 5"	3' - 0"	10 x 20	3 1/2 x 6 1/2	15
1 3/8	15	12	31	6' - 0"	3' - 6"	11 x 22	3 1/2 x 6 1/4	22
1 1/2	18	14	37	6' - 6"	3' - 9"	12 x 24	3 1/2 x 6 1/4	22
1 3/4	25	19	49	7' - 7"	4' - 7"	14 x 28	4 1/2 x 9	30
2	32	24	64	8' - 8"	5' - 6"	16 x 32	6 x 12	37
2-1/4	39	30	77	10' - 0"	-	18 x 36	-	45
2-1/2	47	37	94	11' - 0"	-	20 x 40	-	60

MECHANICAL SPLICE SLINGS—EX. IMP. PLOW STEEL

Mechanical Splice Slings

Extra Improved Plow Steel

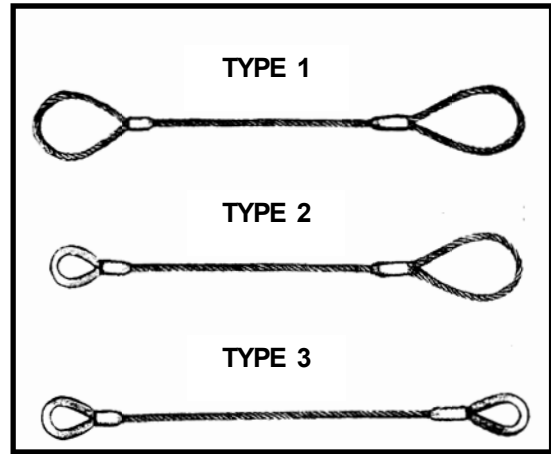
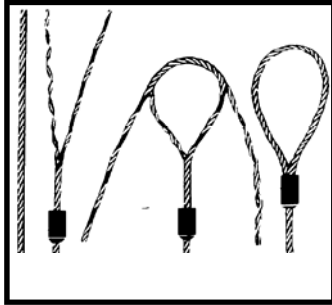

Mechanical Splice Slings - Extra Improved Plow Steel

Rope Dia. (In.)	Vertical	Choker	Vertical Basket	Type 1	Type 3	Standard Eye Size	Thimble Eye Size (In.) W x L	Eye Hook Capacity (Tons)
1/4	0.65	0.48	1.3	1' - 1"	0' - 9"	2 x 4	7/8 x 1 5/8	1
5/16	1.0	0.74	2.0	1' - 4"	0' - 11"	2 1/2 x 5	1 1/16 x 1 7/8	1
3/8	1.4	1.1	2.9	1' - 8"	1' - 1"	3 x 6	1 1/8 x 2 1/8	1 1/2
7/16	1.9	1.4	3.9	1' - 11"	1' - 3"	3 1/2 x 7	1 1/4 x 2 1/4	2
1/2	2.5	1.9	5.1	2' - 2"	1' - 4"	4 x 8	1 1/2 x 2 3/4	3
9/16	3.2	2.4	6.4	2' - 5"	1' - 5"	4 1/2 x 9	1 1/2 x 2 3/4	4 1/2
5/8	3.9	2.9	7.8	2' - 9"	1' - 8"	5 x 10	1 3/4 x 3 1/4	4 1/2
3/4	5.6	4.1	11	3' - 3"	1' - 11"	6 x 12	2 x 3 3/4	7
7/8	7.6	5.6	15	3' - 10"	2' - 3"	7 x 14	2 1/4 x 4 1/4	11
1	9.8	7.2	20	4' - 4"	2' - 6"	8 x 16	2 1/2 x 4 1/2	11
1 1/8	12	9.1	24	4' - 11"	2' - 10"	9 x 18	2 7/8 x 5 1/8	15
1 1/4	15	11	30	5' - 5"	3' - 0"	10 x 20	3 1/2 x 6 1/2	15
1 3/8	18	13	36	6' - 0"	3' - 6"	11 x 22	3 1/2 x 6 1/4	22
1 1/2	21	16	42	6' - 6"	3' - 9"	12 x 24	3 1/2 x 6 1/4	22
1 3/4	28	21	57	7' - 7"	4' - 7"	14 x 28	4 1/2 x 9	30
2	37	28	73	8' - 8"	5' - 6"	16 x 32	6 x 12	37
2-1/4	44	35	89	10' - 0"	-	18 x 36	-	45
2-1/2	54	42	109	11' - 0"	-	20 x 40	-	60

MECHANICAL SPLICE SLINGS—IMP. PLOW STEEL

Mechanical Splice Slings Improved Plow Steel

Mechanical Splice Slings - Improved Plow Steel

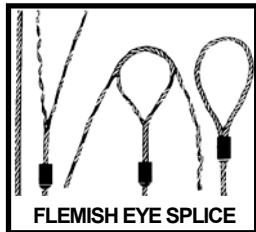

2 Leg Bridle

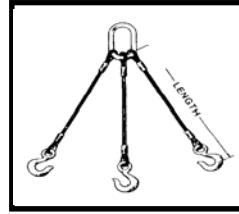

3 Leg Bridle

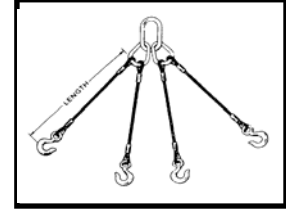

4 Leg Bridle

Rope Dia. (In.)	Min. Sling Length	Eye Hook Cap. (Tons)	30°				Oblong Link Stock Dia.	45°				Oblong Link Stock Dia.	60°			
			30°	45°	60°	Oblong Link Stock Dia.		30°	45°	60°	Oblong Link Stock Dia.		30°	45°	60°	Oblong Link Stock Dia.
1/4	1' 3"	1	0.56	0.79	0.97	1/2	0.84	1.2	1.5	1/2	1.1	1.6	1.9	1/2		
5/16	1' 6"	1	0.87	1.2	1.5	1/2	1.3	1.8	2.3	3/4	1.7	2.5	3.0	3/4		
3/8	1' 8"	1 1/2	1.2	1.8	2.2	3/4	1.9	2.6	3.2	3/4	2.5	3.5	4.3	1		
7/16	1' 10"	2	1.7	2.4	2.9	3/4	2.5	3.6	4.4	1	3.4	4.8	5.9	1		
1/2	2'	3	2.2	3.1	3.8	3/4	3.3	4.6	5.7	1	4.4	6.2	7.6	1 1/4		
9/16	2' 2"	4 1/2	2.8	3.9	4.8	1	4.1	5.8	7.2	1	5.5	7.8	9.5	1 1/4		
5/8	2' 4"	4 1/2	3.4	4.8	5.9	1	5.1	7.2	8.8	1 1/4	6.8	9.6	12	1 1/4		
3/4	2' 9"	7	4.9	6.9	8.4	1 1/4	7.3	10	13	1 1/2	9.7	14	17	1 3/4		
7/8	3' 3"	11	6.6	9.3	11	1 1/4	9.9	14	17	1 1/2	13	19	23	1 3/4		
1	3' 6"	11	8.5	12	15	1 1/2	13	18	22	1 3/4	17	24	30	2 1/4		
1 1/8	4'	15	10	15	18	1 3/4	16	22	27	2	21	30	36	2 3/4		
1 1/4	4' 6"	15	13	18	22	1 3/4	19	27	33	2 1/4	26	36	44	2 3/4		
1 3/8	5'	22	15	22	27	2	23	33	40	2 3/4	31	44	54	-		
1 1/2	5' 6"	22	18	26	32	2 1/4	27	39	48	2 3/4	37	52	63	-		
1 3/4	6' 6"	30	25	35	43	2 3/4	37	52	64	-	49	70	85	-		
2	8'	37	32	45	55	2 3/4	48	67	83	-	64	90	110	-		

¹Minimum length based on thimble eye and eye hook

MECHANICAL SPLICE SLINGS—EX. IMP. PLOW STEEL

Mechanical Splice Slings Extra Improved Plow Steel

Mechanical Splice Slings Extra Improved Plow Steel

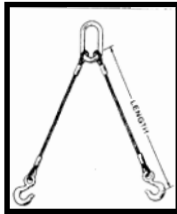
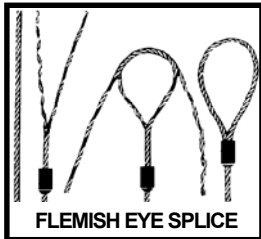

2 Leg Bridle

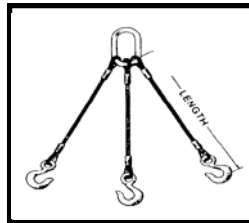

3 Leg Bridle

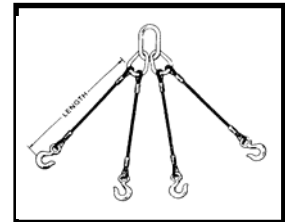

4 Leg Bridle

Rope Dia. (In.)	1 ¹ Min. Sling Length	Eye Hook Cap. (Tons)	Diagram				Oblong Link Stock Dia.	Diagram				Oblong Link Stock Dia.	Diagram				Oblong Link Stock Dia.
			30°	45°	60°			30°	45°	60°			30°	45°	60°		
1/4	1' 3"	1	0.65	0.91	1.1	1/2	0.97	1.4	1.7	1/2	1.3	1.8	2.2	1/2			
5/16	1' 6"	1	1.0	1.4	1.7	1/2	1.5	2.1	2.6	3/4	2.0	2.8	3.5	3/4			
3/8	1' 8"	1 1/2	1.4	2.0	2.5	3/4	2.2	3.0	3.7	3/4	2.9	4.1	5.0	1			
7/16	1' 10"	2	1.9	2.7	3.4	3/4	2.9	4.1	5.0	1	3.9	5.5	6.7	1			
1/2	2'	3	2.5	3.6	4.4	3/4	3.8	5.4	6.6	1	5.1	7.1	8.8	1 1/4			
9/16	2' 2"	4 1/2	3.2	4.5	5.5	1	4.8	6.8	8.3	1	6.4	9.0	11	1 1/4			
5/8	2' 4"	4 1/2	3.9	5.5	6.8	1	5.9	8.3	10	1 1/4	7.8	11	14	1 1/4			
3/4	2' 9"	7	5.6	7.9	9.7	1 1/4	8.4	12	15	1 1/2	11	16	19	1 3/4			
7/8	3' 3"	11	7.6	11	13	1 1/4	11	16	20	1 1/2	15	21	26	1 3/4			
1	3' 6"	11	9.8	14	17	1 1/2	15	21	26	1 3/4	20	28	34	2 1/4			
1 1/8	4'	15	12	17	21	1 3/4	18	26	31	2	24	34	42	2 3/4			
1 1/4	4' 6"	15	15	21	26	1 3/4	22	31	38	2 1/4	30	42	51	2 3/4			
1 3/8	5'	22	18	25	31	2	27	38	46	2 3/4	36	50	62	-			
1 1/2	5' 6"	22	21	30	37	2 1/4	32	45	55	2 3/4	42	60	73	-			
1 3/4	6' 6"	30	28	40	49	2 3/4	42	60	74	-	57	80	98	-			
2	8'	37	37	52	63	2 3/4	55	78	95	-	73	104	127	-			

¹Minimum length based on thimbled eye and eye hook

MECHANICAL SPLICE SLINGS—CABLE LAID BODY

Mechanical Splice Slings Cable Laid Body

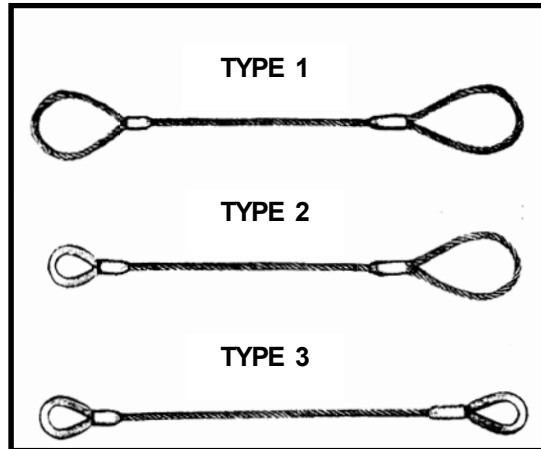

Rope Const.	Rope Dia. (In.)	RATED CAPACITY in Tons*						Standard Eye Size
		Vertical	Choker	Vertical Basket	30°	45°	60°	
7 x 7 x 7	1/4	0.50	0.34	1.0	0.50	0.71	0.87	2 x 4
	3/8	1.1	0.74	2.2	1.1	1.5	1.9	3 x 6
	1/2	1.9	1.3	3.7	1.9	2.6	3.2	4 x 8
	5/8	2.8	1.9	5.5	2.8	3.9	4.8	5 x 10
7 x 7 x 19	3/4	4.1	2.8	8.1	4.1	5.8	7.0	6 x 12
	7/8	5.4	3.4	11.0	5.4	7.6	9.4	7 x 14
	1	6.9	4.7	14.0	6.9	9.7	12	8 x 16
	1-1/8	8.3	5.8	17.0	8.3	12	14	9 x 18
	1-1/4	9.9	7.0	20.0	9.9	14	17	10 x 20
7 x 6 x 19	1-1/2	13	9.0	26	13	18	22	12 x 24

DROP FORGED EYE BOLTS

Drop Forged Eye Bolts

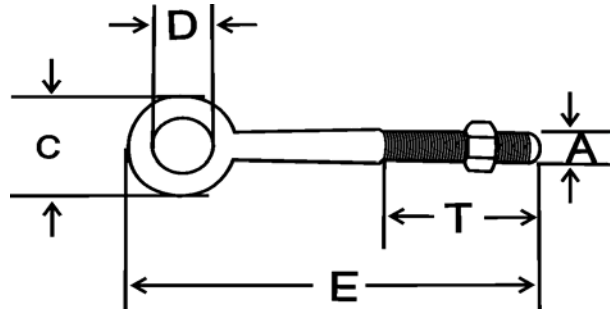

DROP FORGED EYE BOLTS							
Dia. (A) x Shank Length (B)	Part Number	Outside Eye (C)	Inside Eye (D)	Overall Length (E)	Thread Length (T)	Weight per 100 pcs	Working Load Limit
1/4"x2"	080-08005 7	1"	1/2"	3"	1-1/2"	6.4	500
1/4"x3"	080-08008 8	1"	1/2"	4"	1-1/2"	8	500
1/4"x4"	080-08011 8	1"	1/2"	5"	2"	9.3	500
1/4"x5"	080-08014 9	1"	1/2"	6"	2-1/2"	10.4	500
1/4"x6"	080-08017 0	1"	1/2"	7"	3"	11.8	500
5/16"x2-1/4"	080-08022 4	1-1/4"	5/8"	3-1/2"	1-1/2"	12.7	800
5/16"x3-1/4"	080-08025 5	1-1/4"	5/8"	4-1/2"	1-1/2"	15	800
5/16"x4-1/4"	080-08028 6	1-1/4"	5/8"	5-1/2"	2-1/2"	16.5	800
5/16"x5"	080-08031 6	1-1/4"	5/8"	6-1/4"	2-1/2"	18.6	800
5/16"x6"	080-08034 7	1-1/4"	5/8"	7-1/4"	3"	24.5	800
3/8"x2-1/2"	080-08039 2	1-1/2"	3/4"	4"	1-1/2"	19.2	1200
3/8"x3"	080-08042 2	1-1/2"	3/4"	4-1/2"	1-1/2"	21.2	1200
3/8"x4-1/4"	080-08045 3	1-1/2"	3/4"	6"	2"	24.4	1200
3/8"x5"	080-08048 4	1-1/2"	3/4"	6-1/2"	2-1/2"	27.8	1200
3/8"x6"	080-08051 4	1-1/2"	3/4"	7-1/2"	3"	30	1200
3/8"x8"	080-08054 5	1-1/2"	3/4"	9-1/2"	4"	36	1200
1/2"x2"	080-08059 0	2"	1"	4"	1-7/8"	38.5	2200
1/2"x3-1/4"	080-08062 0	2"	1"	5-1/4"	1-1/2"	46	2200
1/2"x4-1/2"	080-08065 1	2"	1"	6-1/2"	2"	53	2200
1/2"x6"	080-08068 2	2"	1"	8"	3"	60	2200
1/2"x8"	080-08071 2	2"	1"	10"	4"	71	2200
1/2"x10"	080-08074 3	2"	1"	12"	4"	83	2200
1/2"x12"	080-08077 4	2"	1"	14"	4"	96	2200
5/8"x4-1/2"	080-08082 8	2-5/16"	1-1/4"	6-13/16"	2"	79	3500
5/8"x6"	080-08085 9	2-5/16"	1-1/4"	8-5/16"	3"	96	3500

Table Continues on the Next Page

DROP FORGED EYE BOLTS

Drop Forged Eye Bolts

Table Continued from Previous Page

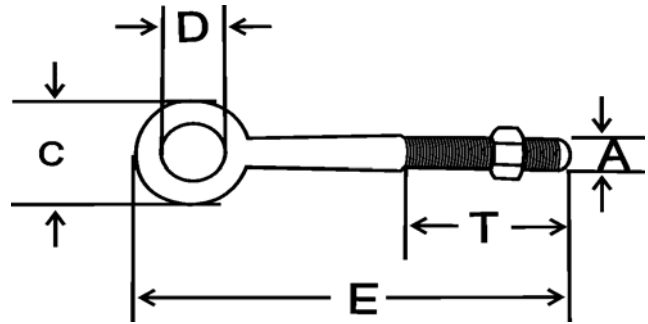

DROP FORGED EYE BOLTS (Continued)							
Dia. (A) x Shank Length (B)	Part Number	Outside Eye (C)	Inside Eye (D)	Overall Length (E)	Thread Length (T)	Weight per 100 pcs	Working Load Limit
5/8"x8"	080-08088 0	2-5/16"	1-1/4"	10-5/16"	4"	128	3500
5/8"x10"	080-08091 0	2-5/16"	1-1/4"	12-5/16"	4"	129.5	3500
5/8"x12"	080-08094 1	2-5/16"	1-1/4"	14-5/16"	4"	146	3500
5/8"x15"	080-08097 2	2-5/16"	1-1/4"	17-5/16"	6"	168	3500
5/8"x18"	080-08100 9	2-5/16"	1-1/4"	20-5/16"	6"	195	3500
5/8"x24"	080-08103 0	2-5/16"	1-1/4"	26-5/16"	6"	246	3500
3/4"x4-1/2"	080-08108 5	2-3/4"	1-1/2"	7-1/4"	2-1/2"	126	5200
3/4"x6"	080-08111 5	2-3/4"	1-1/2"	8-3/4"	3"	160	5200
3/4"x8"	080-08114 6	2-3/4"	1-1/2"	10-3/4"	4"	180	5200
3/4"x10"	080-08117 7	2-3/4"	1-1/2"	12-3/4"	4"	200	5200
3/4"x12"	080-08120 7	2-3/4"	1-1/2"	14-3/4"	4"	233	5200
3/4"x15"	080-08123 8	2-3/4"	1-1/2"	17-3/4"	6"	254	5200
3/4"x18"	080-08126 9	2-3/4"	1-1/2"	20-3/4"	6"	290	5200
3/4"x24"	080-08129 0	2-3/4"	1-1/2"	26-3/4"	6"	369	5200
7/8"x5"	080-08134 4	3-1/2"	1-3/4"	8-1/2"	2-1/2"	245	7000
7/8"x8"	080-08137 5	3-1/2"	1-3/4"	11-1/2"	4"	296	7000
7/8"x12"	080-08140 5	3-1/2"	1-3/4"	15-1/2"	4"	366	7000
7/8"x18"	080-08143 6	3-1/2"	1-3/4"	21-1/2"	6"	464	7000
7/8"x24"	080-08146 7	3-1/2"	1-3/4"	27-1/2"	6"	556	7000
1"x6"	080-08151 1	3-3/4"	2"	9-3/4"	3"	301	10000
1"x9"	080-08154 2	3-3/4"	2"	12-3/4"	4"	383	10000
1"x12"	080-08157 3	3-3/4"	2"	15-3/4"	4"	450	10000
1"x18"	080-08160 3	3-3/4"	2"	21-3/4"	6"	584	10000
1"x24"	080-08163 4	3-3/4"	2"	27-3/4"	6"	716	10000

DROP FORGED EYE BOLTS (SHOULDER)

Drop Forged Eye Bolts (Shoulder)

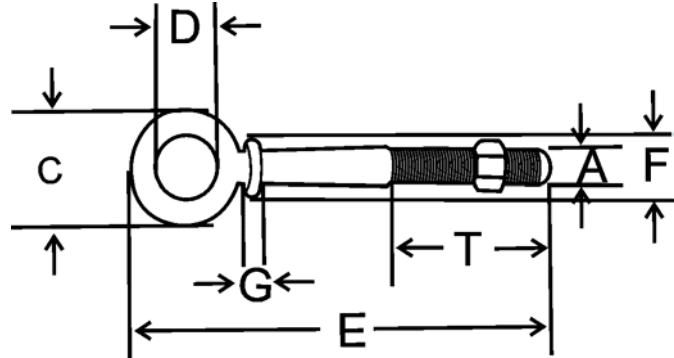

DROP FORGED EYE BOLTS (SHOULDER)									
Dia. (A) x Shank Length (B)	Part Number	Out-side Eye	Inside Eye (D)	Overall Length (E)	Outside Shoulder (F)	Thickness At Shoulder	Thread Length (T)	Weight per 100 pcs	Working Load Limit
1/4"x2"	080-08405	1"	1/2"	3-1/8"	7/16"	5/64"	1-1/2"	7.4	500
1/4"x4"	080-08411	1"	1/2"	5-1/8"	7/16"	5/64"	2"	10.7	500
5/16"x2-	080-08422	1-1/4"	5/8"	3-5/8"	9/16"	3/32"	1-1/2"	12.9	800
5/16"x4-	080-08428	1-1/4"	5/8"	5-5/8"	9/16"	3/32"	2-1/2"	16.8	800
3/8"x2-1/2"	080-08439	1-1/2"	3/4"	4-1/4"	11/16"	1/8"	1-1/2"	21	1200
3/8"x4-1/4"	080-08445	1-1/2"	3/4"	6-1/4"	11/16"	1/8"	2"	29	1200
1/2"x2"	080-08459	2"	1"	4-5/16"	7/8"	5/32"	1-7/8"	44	2200
1/2"x3-1/4"	080-08462	2"	1"	5-1/2"	7/8"	5/32"	1-1/2"	46	2200
1/2"x6"	080-08468	2"	1"	8-1/4"	7/8"	5/32"	3"	63	2200
5/8"x4-1/2"	080-08482	2-5/16"	1-1/4"	7-1/4"	1-1/8"	13/64"	2"	99	3500
5/8"x6"	080-08485	2-5/16"	1-1/4"	8-9/16"	1-1/8"	13/64"	3"	103	3500
3/4"x4-1/2"	080-08508	2-3/4"	1-1/2"	7-3/4"	1-3/8"	1/4"	2-1/2"	152	5200
3/4"x6"	080-08511	2-3/4"	1-1/2"	9-1/8"	1-3/8"	1/4"	3"	166	5200
7/8"x5"	080-08534	3-1/2"	1-3/4"	9-1/4"	1-1/2"	9/32"	2-1/2"	222	7000
7/8"x8"	080-08537	3-1/2"	1-3/4"	12-1/8"	1-1/2"	9/32"	4"	269	7000
1"x6"	080-08551	3-3/4"	2"	10-1/2"	1-3/4"	5/16"	3"	331	10000
1"x9"	080-08554	3-3/4"	2"	13-1/4"	1-3/4"	5/16"	4"	404	10000

Table Continues on the Next Page

DROP FORGED EYE NUTS

Drop Forged Eye Nuts

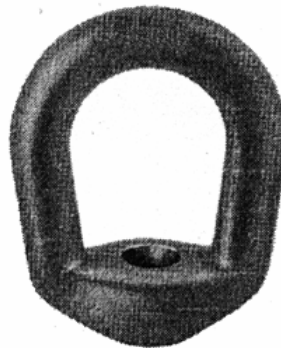

Regular

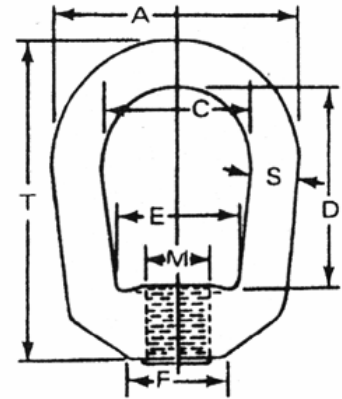

DROP FORGED EYE NUTS* Dimensions—Inches				
Regular Eye Nuts		Blank	Drilled & Tapped	
Bail Size	Tap Size	Self-Colored Part	Self-Colored Part No.	Hot Galvanized Part No.
1/4"	1/4"-20	080-16005 6	080-16255 5	080-16755 5
1/4"	5/16"-18	080-16010 0	080-16260 9	080-16760 9
5/16"	3/8"-16	080-16015 5	080-16265 4	080-16765 9
3/8"	7/16"-14	080-16020 9	080-16270 8	080-16770 8
3/8"	1/2"-13	080-16025 4	080-16275 3	080-16775 8
1/2"	5/8"-11	080-16030 8	080-16280 7	080-16780 2
5/8"	3/4"-10	080-16035 3	080-16285 2	080-16785 7
3/4"	7/8"-9	080-16040 7	080-16290 6	080-16790 1
3/4"	1"-8	080-16045 2	080-16295 1	080-16795 6

Stock Eye Nuts listed, other than blanks, are drilled and tapped standard regardless of finish. Both types drilled only, with special tapping or finish supplied to specification. Loads are based on a safety factor of 5 to 1. Blanks are self-colored.

Tap Sizes		Dimensions—Inches							WLL (Tons)	Drilled & Tapped Weight
Std. M	Max. N	A	C	D	E	F	S	T		
1/4"-20	3/8"	1-1/4"	3/4"	1-	19/32"	1/2"	1/4"	1-11/16"	.26	8.2
5/16"-18	3/8"	1-1/4"	3/4"	1-	19/32"	1/2"	1/4"	1-11/16"	.42	8
3/8"-16	7/16"	1-5/8"	1"	1-1/4"	3/4"	9/16"	5/16"	2-1/16"	.62	15.7
7/16"-14	1/2"	2"	1-1/4"	1-1/2"	1"	13/16"	3/8"	2-1/2"	.85	29.7
1/2"-13	1/2"	2"	1-1/4"	1-1/2"	1"	13/16"	3/8"	2-1/2"	1.12	29.3
5/8"-11	3/4"	2-1/2"	1-1/2"	2"	1-	1"	1/2"	3-3/16"	1.8	61.5
3/4"-10	7/8"	3"	1-3/4"	2-3/8"	1-3/8"	1-1/8"	5/8"	3-7/8"	2.6	103
7/8"-9	1"	3-1/2"	2"	2-5/8"	1-5/8"	1-5/16"	3/4"	4-5/16"	3.6	163
1"-8	1"	3-1/2"	2"	2-5/8"	1-5/8"	1-5/16"	3/4"	4-5/16"	3.6	161

DROP FORGED HEAVY DUTY EYE NUTS & PAD EYES

Drop Forged Heavy Duty Eye Nuts

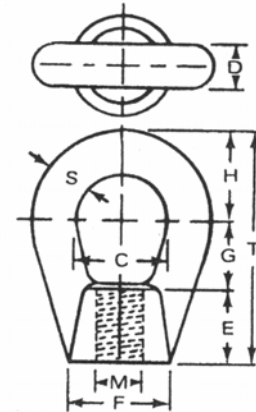

DROP FORGED EYE NUTS											
Part No.	Dimensions—Inches									WLL	Drilled & Tapped
	C	S	D	M	F	E	G	H	T		
080-100	7/8"	5/16"	5/16"	3/8-16"	3/4"	3/4"	3/4"	3/4"	2-1/4"	.9	15
080-101	1-1/8"	7/16"	7/16"	1/2-13"	1"	1"	1"	1"	3"	1.8	37.5
080-102	1-3/8"	9/16"	9/16"	5/8-11"	1-1/4"	1-1/4"	1-1/4"	1-1/4"	3-3/4"	2.9	82.5
080-103	1-1/2"	3/4"	3/4"	3/4-10"	1-3/4"	1-1/4"	1-1/8"	1-1/2"	3-7/8"	5.3	145
080-104	1-5/8"	7/8"	7/8"	7/8-9"	2"	1-1/4"	1"	1-	3-15/16"	7.2	202.5
080-105	1-3/4"	1"	1"	1-8"	2-1/4"	1-5/8"	1-1/4"	1-7/8"	4-3/4"	9.4	327.5
080-105A	1-3/4"	1"	1"	1-1/8-7"	2-1/4"	1-5/8"	1-1/4"	1-7/8"	4-3/4"	11.3	297
080-106	2"	1-1/4"	1-1/4"	1-1/4-7"	2-7/8"	1-7/8"	1-3/8"	2-1/4"	5-1/2"	14.7	550
080-107	2-1/2"	1-3/8"	1-3/8"	1-1/2-6"	3-1/8"	2-1/8"	1-3/4"	2-5/8"	6-1/2"	17.8	807.5



Drop Forged Pad Eyes

DROP FORGED PAD EYES						
Part No.	EYE		SHOULDER		*Overall Height	Weight Per 100 in Lbs.
	I.D.	O.D.	O.D.	*Thickness		
080-22005 7	1/4"	5/8"	5/8"	3/32"	3/4"	3.3
080-22010 1	3/4"	1-1/2"	1-1/16	3/16"	1-5/8"	18.6
080-22015 6	1-3/16"	2-1/16"	1-11/16"	3/16"	2-3/8"	49
080-22020 0	1-1/4"	2-3/8"	2"	3/16"	2-7/8"	81

*Forged from carbon steel suitable for welding; Supplied with self-colored finish; Not Including draft.

STEEL SWAGE BUTTONS

Steel Swage Buttons

Use the "Hoist Cable Worksheet" to Detail your Fitting Dimensions.

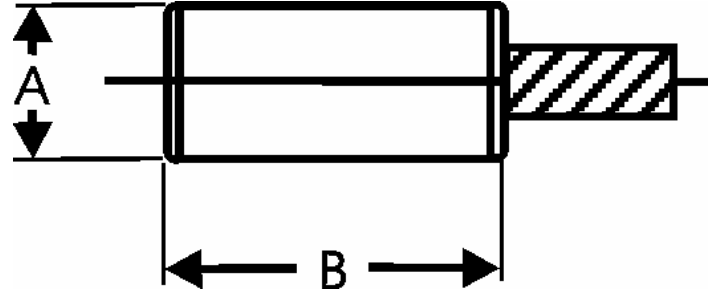

STEEL SWAGE BUTTONS—CONFORMS TO INDUSTRY STANDARDS					
		AFTER SWAGE DIMENSION			
Part Number	Rope Dia.	A		B Approx.	Weight Each
430-NB-4	1/8	3/8	+ .010	5/8	.025 lb.
430-NB-5	5/32	7/16	- .010	3/4	.031 lb.
430-NB-6	3/16	1/2		7/8	.050 lb.
430-NB-7	7/32	9/16		1	.062 lb.
430-NB-8	1/4	9/16		1 3/16	.068 lb.
430-NB-9	9/32	11/16		1 1/4	.113 lb.
430-NB-10	5/16	3/4		1 3/8	.156 lb.
430-NB-12	3/8	3/4	+ .020	1 3/4	.188 lb.
430-NB-14	7/16	1	- .020	2	.393 lb.
430-NB-16	1/2	1 1/8		2 3/16	.544 lb.
430-NB-18	9/16	1 1/4		2 7/16	.737 lb.
430-NB-20	5/8	1 3/8		2 7/8	1.062 lb.
430-NB-24	3/4	1 1/2		3 1/4	1.356 lb.
430-NB-28	7/8	1 3/4		3 7/8	2.194 lb.
430-NB-32	1	2		4 3/8	3.150 lb.
430-NB-36	1 1/8	2 1/4	+ .030	4 13/16	4.575 lb.
430-NB-40	1 1/4	2 1/2	- .030	5 7/16	7.000 lb.
430-NB-44	1 3/8	2 3/4		6	9.150 lb.
430-NB-48	1 1/2	3		6 1/2	12.025 lb.

STANDARD SWAGE BUTTONS

Standard Swage Buttons

Use the "Hoist Cable Worksheet" to Detail your Fitting Dimensions.

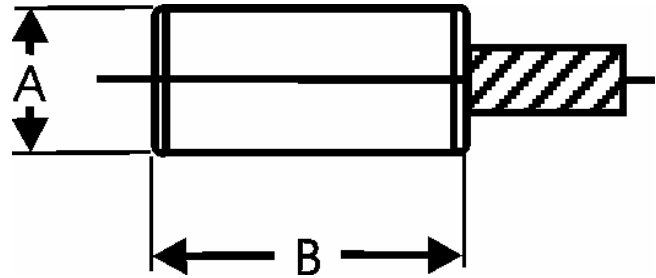

STANDARD SWAGE BUTTONS—CONFORMS TO INDUSTRY STANDARDS					
		AFTER SWAGE DIMENSION			
Part Number	Rope Dia.	A		B Approx.	Weight Each
430-SB-4	1/8	3/8	+010	5/8	.025 lb.
430-SB-5	5/32	7/16	-.010	3/4	.031 lb.
430-SB-6	3/16	1/2		7/8	.050 lb.
430-SB-7	7/32	9/16		1	.062 lb.
430-SB-8	1/4	5/8		1 1/8	.087 lb.
430-SB-9	9/32	11/16		1 3/8	.113 lb.
430-SB-10	5/16	3/4		1 1/2	.168 lb.
430-SB-12	3/8	7/8	+020	1 3/4	.268 lb.
430-SB-14	7/16	1	-.020	2	.393 lb.
430-SB-16	1/2	1 1/8		2 3/8	.594 lb.
430-SB-18	9/16	1 1/4		2 5/8	.806 lb.
430-SB-20	5/8	1 3/8		2 7/8	1.062 lb.
430-SB-24	3/4	1 1/2		3 1/2	1.456 lb.
430-SB-28	7/8	1 3/4		4 1/8	2.318 lb.
430-SB-32	1	2		4 3/4	3.425 lb.
430-SB-36	1 1/8	2 1/4	+030	5 1/4	4.956 lb.
430-SB-40	1 1/4	2 1/2	-.030	5 7/8	7.018 lb.
430-SB-44	1 3/8	2 3/4		6 1/2	9.188 lb.
430-SB-48	1 1/2	3		7 1/8	12.025 lb.

SPECIAL STOCK SWAGE BUTTONS

Special Stock Swage Buttons

SPECIAL STOCK STEEL SWAGE BUTTONS—CONFORMS TO INDUSTRY STANDARDS				
Part Number	Rope Dia.	AFTER SWAGE DIMENSION		
		A	B	Weight Each
430-G6-4	3/16	0.375	0.875	.025 lb.
430-G6-8	3/16	0.500	0.813	.044 lb.
430-G6-12	3/16	0.750	1.125	.144 lb.
430-G7-5	7/32	0.563	0.938	.062 lb.
430-G8-8	1/4	0.500	1.000	.043 lb.
430-G8-14	1/4	0.500	1.125	.045 lb.
430-G8-16	1/4	0.500	1.500	.048 lb.
430-G8-20	1/4	0.500	0.875	.075 lb.
430-G8-24	1/4	0.625	1.250	.100 lb.
430-G8-28	1/4	0.625	1.500	.119 lb.
430-G8-32	1/4	0.625	1.125	.131 lb.
430-G8-36	1/4	0.750	1.250	.150 lb.
430-G8-40	1/4	0.750	1.500	.181 lb.
430-G8-44	1/4	0.750	1.000	.175 lb.
430-G-10-3	5/16	0.750	1.250	.137 lb.
430-G10-4	5/16	0.875	0.875	.143 lb.
430-G10-8	5/16	0.875	1.000	.169 lb.
430-G10-12	5/16	0.875	1.250	.200 lb.
430-G10-16	5/16	0.875	1.500	.243 lb.
430-G10-20	5/16	0.875	2.000	.325 lb.
430-G10-24	5/16	1.000	1.438	.313 lb.
430-G10-28	5/16	1.000	1.500	.313 lb.
430-G12-2	3/8	0.750	1.500	.156 lb.
430-G12-3	3/8	0.875	1.500	.231 lb.
430-G12-4	3/8	1.000	1.500	.313 lb.
430-G12-12	3/8	1.000	2.000	.419 lb.
430-G12-16	3/8	1.250	2.000	.681 lb.
430-G14-2	7/16	1.000	1.375	.256 lb.
430-G14-8	7/16	1.000	1.750	.344 LB.
430-G16-2	1/2	1.000	1.750	.325 lb.
430-G16-3	1/2	1.125	2.000	.500 lb.
430-G16-4	1/2	1.250	1.250	400 lb.
430-G16-5	1/2	1.250	1.750	.569 lb.
430-G20-3	5/8	1.375	2.500	.925 lb.
430-G24-4	3/4	1.500	2.000	.831 lb.
430-G28-4	7/8	1.750	2.791	1.613 lb.
430-G28-8	7/8	1.750	3.000	1.738 lb.

CAST DRUMLINE & MACHINED END FERRULES

Cast Drumline & Machined End Ferrules

Use the "Hoist Cable Worksheet" to Detail your Fitting Dimensions.

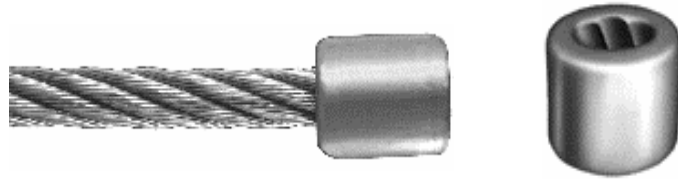

CAST DRUMLINE FERRULES								
Part Number	Rope Size	Ferrule	Weight Each	Before Swaging		After Swaging		Die Desc.
				Length	Dia.	Length	Dia.	
160-5100075	3/4	B 6	0.8	1-3/4"	1-3/4"	2"	1.53"	3/4" OC
160-5103663	3/4	L 6	2	2"	2-5/16"	2-1/4"	2.04"	1" OC
160-5103665	7/8	L 7	2	2"	2-5/16"	2-1/4"	2.04"	1" OC
160-5103668	1	L 8	2	2"	2-5/16"	2-1/4"	2.04"	1" OC
160-5103406	1	J 8	2.2	2-1/8"	2-9/16"	2-3/8"	2.26"	1-1/8" OC
160-5103408	1 1/8	J 9	2.2	2-1/8"	2-9/16"	2-3/8"	2.26"	1-1/8" OC
160-5103404	1 1/4	J 10	2.2	2-1/8"	2-9/16"	2-3/8"	2.26"	1-1/8" OC

OC = Open Channel Die All Dimensions are for reference only.



MACHINED END FITTINGS								
Part Number	Rope Size	Ferrule	Weight Each	Before Swaging		After Swaging		Die Desc.
				Length	Dia.	Length	Dia.	
160-4134053	3/16	3/16" DE	0.12	5/8"	5/8"	13/16"	0.53"	1/4" OC
160-4005964	1/4	1/4" DE	0.17	7/8"	5/8"	1-1/8"	0.53"	1/4" OC
160-4005965	5/16	5/16" DE	0.2	1"	7/8"	1-1/4"	0.76"	3/8" OC
160-4005957	3/8	3/8" DE	0.25	1-1/4"	7/8"	1-9/16"	0.76"	3/8" OC
160-4005960	7/16	7/16" DES	0.25	1-1/2"	1"	1-3/4"	0.88"	7/16" OC
160-4005958	7/16	7/16" DE	0.33	1-1/2"	1-1/8"	1-3/4"	1.01"	1/2" OC
160-4014054	1/2	1/2" DE	0.33	1-5/8"	1-1/8"	1-7/8"	1.01"	1/2" OC
160-4017636	1/2	1/2" TH	0.4	1-11/32"	1-5/16"	1-1/2"	1.13"	9/16" OC
160-4017637	9/16	9/16" TH	0.4	1-11/32"	1-5/16"	1-1/2"	1.13"	9/16" OC

Note: For 5/8" Drumlines, use DB5P Choker Ferrules; OC = Open Channel Die
All Dimensions are for reference only.

HOIST CABLE WORKSHEET

Hoist Cable Worksheet

(DEF) DEAD END FERRULE PART NUMBER: _____

OVERALL LENGTH _____

LENGTH OF _____

LENGTH BETWEEN SLEEVES _____

TYPE OF CONSTRUCTION

_____ DIAMETER OF ROPE _____ TYPE OF CORE _____

_____ NUMBER OF STRANDS _____ TYPE OF FINISH _____

_____ NUMBER OF WIRES PER STRAND _____ LAY OF ROPE _____

_____ STRENGTH OF ROPE

SLEEVE OR FERRULE BOTH ENDS? _____

TYPE OF FITTING OTHER END _____

OPEN WEDGE SOCKETS & ONE SHEAVE SNATCH

Open Wedge Sockets & One Sheave Snatch Blocks

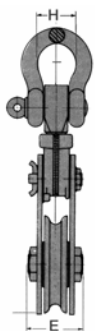
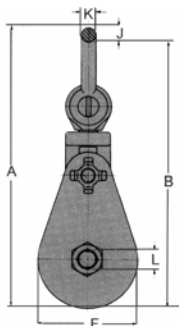
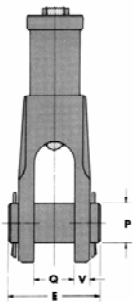
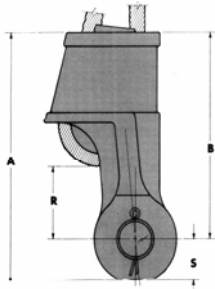

OPEN WEDGE SOCKETS										
Part No.	Wire	Weigh	A	B	E	P	Q	R	S	V
190-WS4	3/8	3	6.500	5.375	2.625	1	1	1.75	1.125	.375
190-WS4	1/2	3	6.500	5.375	2.625	1	1	1.93	1.125	.375
190-WS5	1/2	8.5	8.750	7.250	3.500	1.250	1.375	2.43	1.500	.625
190-WS5	9/16	8.5	8.750	7.250	3.500	1.250	1.375	2.81	1.500	.625
190-WS5	5/8	8,5	8.750	7.250	3.500	1.250	1.375	2.75	1.500	.625
190-WS6	5/8	9	8.812	7.312	3.500	1.250	1.500	2.50	1.500	.562
190-WS8A	5/8	17	11.25	9.125	4.125	1.625	1.750	3.18	2.125	1
190-WS6	3/4	9	8.812	7.312	3.500	1.250	1.500	1.78	1.500	.562
190-WS8A	3/4	17	11.25	9.125	4.125	1.625	1.312	2.84	2.125	1
190-WS7	7/8	15	11	9.500	3.500	1.250	1.750	2.93	1.500	.625
190-WS8	7/8	16	11.37	9.500	4.125	1.625	1.315	2.87	1.875	.750
190-WS7	1	14.5	11	9.500	3.500	1.250	1.750	2.87	1.500	.625
190-WS8	1	16	11.37	9.500	4.125	1.625	1.750	2.50	1.875	.750
190-WS10	1-1/8	45	15.43	13.25	4.125	1.625	2.500	3.06	2.187	.750
190-WS11	1-1/8	55	16	13.50	5.500	2.500	1.750	4.50	2.500	.812
190-WS10	1-1/4	45	15.43	12.25	4.125	1.625	1.750	3.12	2.187	.750
190-WS11	1-1/4	55	16	13.50	5.500	2.500	2.500	4.25	2.500	.812
190-FS-26	1-1/2	99	18.37	15	6.875	3	2.625	4.18	3.375	1.25

ONE SHEAVE SNATCH BLOCKS												
Part No.	Stan.	Wt.	A	B	E	F	H	H	J	K	L	P, Q
2-TON 1-SHEAVE SNATCH BLOCKS WITH SHACKLE, 3 INCHES												
190-SB2S3BS	5/16-	9	10.814	10.314	2.500	3.375	1.312	N/A	.500	.500	.750	N/A
2-TON 1-SHEAVE SNATCH BLOCKS WITH HOOK, 3 INCHES												
190-SB2S3BH	5/16-	9	10.500	9.500	2.500	3.375	1.125	1.000	1.000	.688	.750	N/A
2-TON 1-SHEAVE SNATCH BLOCKS WITH TAILBOARD, 3 INCHES												
190-SB2S3BT	5/16- 3/8	9	5.650	4.750	3.000	3.375	N/A	N/A	N/A	N/A	.750	.750, 1.440
2-TON 1-SHEAVE SNATCH BLOCKS WITH EYE, 3 INCHES												
190-SB2S3BE	5/16-	7	8.980	8.420	3.000	3.375	1.250	N/A	.625	.625	.750	N/A

ONE SHEAVE SNATCH BLOCKS WITH HOOK

One Sheave Snatch Blocks with Hook

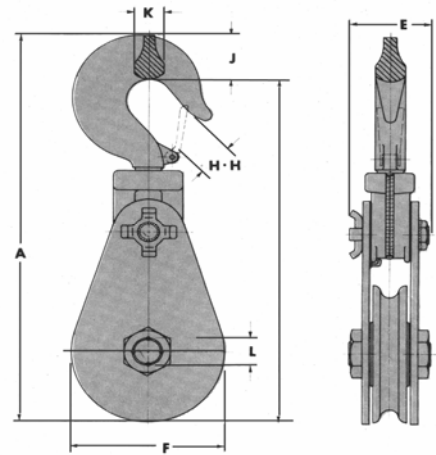

Part Number	Stan.	Max.	Wgt	A	B	E	F	H	H	J	K	L
4-TON 1-SHEAVE SNATCH BLOCKS WITH HOOK, 4-14 INCHES												
190-SB4S4BH	3/8-1/2	3/4	15	14.50	12.62	3.281	4.750	1.437	1.25	1.87	1.12	1
190-SB4S4RH	3/8-1/2	3/4	15	14.50	12.62	3.281	4.750	1.437	1.25	1.87	1.12	1
190-SB4S6BH	3/8-1/2	3/4	18	16.62	14.75	3.281	6.250	1.437	1.25	1.87	1.12	1
190-SB4S6RH	3/8-1/2	3/4	18	16.62	14.75	3.281	6.250	1.437	1.25	1.87	1.12	1
190-SB4S8BH	3/8-1/2	3/4	22	18.62	16.75	3.281	8.250	1.437	1.25	1.87	1.12	1
190-SB4S8RH	3/8-1/2	3/4	22	18.62	16.75	3.281	8.250	1.437	1.25	1.87	1.12	1
190-SB4S10BH	3/8-1/2	3/4	34	20.62	18.75	3.281	10.250	1.437	1.25	1.87	1.12	1.25
190-SB4S10RH	3/8-1/2	3/4	34	20.62	18.75	3.281	10.250	1.437	1.25	1.87	1.12	1.25
190-SB4S12BH	3/8-1/2	7/8	39	22.62	20.75	3.281	12.250	1.437	1.25	1.87	1.12	1.25
190-SB4S12RH	3/8-1/2	7/8	39	22.62	20.75	3.281	12.250	1.437	1.25	1.87	1.12	1.25
190-SB4S14BH	3/8-1/2	3/4	41	24.62	22.75	3.281	14.250	1.437	1.25	1.87	1.12	1.25
190-SB4S14RH	3/8-1/2	3/4	41	24.62	22.75	3.281	14.250	1.437	1.25	1.87	1.12	1.25
8-TON 1-SHEAVE SNATCH BLOCKS WITH HOOK, 6-14 INCHES												
190-SB8S6BH	5/8-3/4	1	29	19	16.87	3.687	6.250	2	1.75	2.125	1.375	1.500
190-SB8S6RH	5/8-3/4	1	29	19	16.87	3.687	6.250	2	1.75	2.125	1.375	1.500
190-SB8S8BH	5/8-3/4	7/8	32	21	18.87	3.687	8.250	2	1.75	2.125	1.375	1.500
190-SB8S8RH	5/8-3/4	7/8	32	21	18.87	3.687	8.250	2	1.75	2.125	1.375	1.500
190-SB8S10BH	5/8-3/4	3/4	40	23	20.87	3.687	10.250	2	1.75	2.125	1.375	1.500
190-SB8S10RH	5/8-3/4	3/4	40	23	20.87	3.687	10.250	2	1.75	2.125	1.375	1.500
190-SB8S12BH	5/8-3/4	7/8	46	25	22.87	3.687	12.250	2	1.75	2.125	1.375	1.500
190-SB8S12RH	5/8-3/4	7/8	46	25	22.87	3.687	12.250	2	1.75	2.125	1.375	1.500
190-SB8S14BH	5/8-3/4	7/8	58	27	24.87	3.687	14.250	2	1.75	2.125	1.375	1.500
190-SB8S14RH	5/8-3/4	7/8	58	27	24.87	3.687	14.250	2	1.75	2.125	1.375	1.500

Table Continues on the Next Page

ONE SHEAVE SNATCH BLOCKS WITH HOOK

One Sheave Snatch Blocks with Hook

Table Continued from Previous Page

Part Number	Stan. Wire Rope Size	Max. Allow.	Weight	A	B	E	F	H	H	J	K	L
12-TON 1-SHEAVE SNATCH BLOCKS WITH HOOK, 6-16 INCHES												
190-SB12S6BH	3/4-7/8	1-1/8	42	20.750	18.125	4.375	6.250	2.500	2.125	2.625	1.625	2
190-SB12S6RH	3/4-7/8	1-1/8	42	20.750	18.125	4.375	6.250	2.500	2.125	2.625	1.625	2
190-SB12S8BH	3/4-7/8	1-1/8	53	22.750	20.125	4.375	8.250	2.500	2.125	2.625	1.625	2
190-SB12S8RH	3/4-7/8	1-1/8	53	22.750	20.125	4.375	8.250	2.500	2.125	2.625	1.625	2
190-SB12S10BH	3/4-7/8	1-1/8	66	24.750	22.125	4.375	10.250	2.500	2.125	2.625	1.625	2
190-SB12S10RH	3/4-7/8	1-1/8	66	24.750	22.125	4.375	10.250	2.500	2.125	2.625	1.625	2
190-SB12S12BH	3/4-7/8	1-1/8	75	26.750	24.125	4.375	12.250	2.500	2.125	2.625	1.625	2
190-SB12S12RH	3/4-7/8	1-1/8	75	26.750	24.125	4.375	12.250	2.500	2.125	2.625	1.625	2
190-SB12S14BH	3/4-7/8	1-1/8	92	28.750	26.125	4.375	14.250	2.500	2.125	2.625	1.625	2
190-SB12S14RH	3/4-7/8	1-1/8	92	28.750	26.125	4.375	14.250	2.500	2.125	2.625	1.625	2
190-SB12S16BH	3/4-7/8	7/8	119	30.750	28.125	4.375	16.250	2.500	2.125	2.625	1.625	2
190-SB12S16RH	3/4-7/8	7/8	119	30.750	28.125	4.375	16.250	2.500	2.125	2.625	1.625	2
22-TON 1-SHEAVE SNATCH BLOCKS WITH HOOK, 8-18 INCHES												
190-SB22S8BH	1—1-1/8	1-1/2	102	28.125	25.125	5.312	8.625	3.375	3	3	2.375	2.250
190-SB22S8RH	1—1-1/8	1-1/2	102	28.125	25.125	5.312	8.625	3.375	3	3	2.375	2.250
190-SB22S10BH	1—1-1/8	1-1/2	125	30	27	5.312	10.375	3.375	3	3	2.375	2.250
190-SB22S10RH	1—1-1/8	1-1/2	125	30	27	5.312	10.375	3.375	3	3	2.375	2.250
190-SB22S12BH	1—1-1/8	1-1/4	131	32	29	5.312	12.500	3.375	3	3	2.375	2.250
190-SB22S12RH	1—1-1/8	1-1/4	131	32	29	5.312	12.500	3.375	3	3	2.375	2.250
190-SB22S14BH	1—1-1/8	1-3/8	149	34.125	31.125	5.312	14.500	3.375	3	3	2.375	2.250
190-SB22S14RH	1—1-1/8	1-3/8	149	34.125	31.125	5.312	14.500	3.375	3	3	2.375	2.250
190-SB22S16BH	1—1-1/8	1-1/8	178	33	33	5.312	16.125	3.375	3	3	2.375	2.250
190-SB22S16RH	1—1-1/8	1-1/8	178	33	33	5.312	16.125	3.375	3	3	2.375	2.250
190-SB22S18BH	1—1-1/8	1-1/8	214	35	35	5.312	18.125	3.375	3	3	2.375	3.500
190-SB22S18RH	1—1-1/8	1-1/8	214	35	35	5.312	18.125	3.375	3	3	2.375	3.500
30-TON 1-SHEAVE SNATCH BLOCKS WITH HOOK, 20-24 INCHES												
190-SB30S20BH	1-1/8—1-1/4	1-3/8	341	47.875	44.125	5.875	20.250	4	3.625	3.750	3	3.500
190-SB30S20RH	1-1/8—1-1/4	1-3/8	341	47.875	44.125	5.875	20.250	4	3.625	3.750	3	3.500
190-SB30S24BH	1-1/8—1-1/4	1-3/8	461	52	48.250	5.875	24.625	4	3.625	3.750	3	3.500
190-SB30S24RH	1-1/8—1-1/4	1-3/8	461	52	48.250	5.875	24.625	4	3.625	3.750	3	3.500

OBLONG MASTER RINGS

Oblong Master Rings

Manufactured with a 5:1 Design Factor

Oblong Master Ring Specification, with Flat Specifications

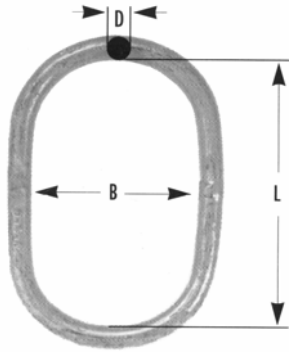

Size ins.	Product Code	WLL (lbs.)	Dimensions (ins.)			Weight
			L	B	D	
3/8	589614	3,300	3.9	2.4	.43	.4
1/2	589615	7,000	4.7	2.8	.55	.9
5/8	589616	11,400	5.5	3.2	.67	1.5
3/4	589617	12,300	5.9	3.5	.75	2.2
7/8	589618	17,200	6.3	3.7	.87	3.3
1	589619	29,900	7.5	4.3	.99	4.8
1-1/4	589620	35,200	7.9	4.7	1.2	7.7
1-3/8	589621	45,300	9.5	5.5	1.3	11.0
1-1/2	589622	68,000	9.9	5.9	1.5	15.0
1-5/8	589623	70,400	9.9	5.9	1.6	18.0
1-3/4	589624	84,900	11.8	7.1	1.8	26.0
2	589625	102,600	11.8	7.9	2.0	33.0
2-1/4	589626	143,100	11.8	7.9	2.2	40.0
2-1/2	589627	160,000	13.8	7.9	2.4	55.0
2-3/4	589628	220,200	15.8	9.9	2.8	88.0
3-1/4	589629	275,300	15.8	9.9	3.2	117.0

Oblong Master Ring with Sub-Assemblies Specifications

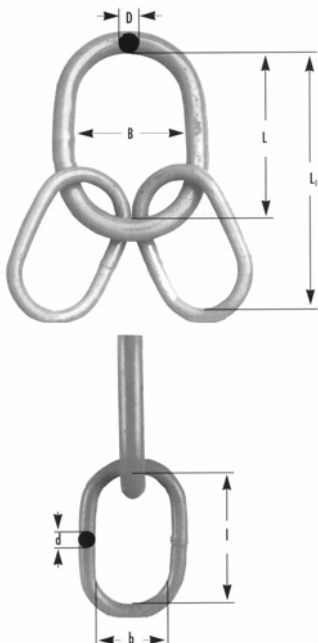

Size ins.	Product Code	WLL (lbs.)	Dimensions (ins.)							Weight
			L1	L	B	D	l	b	d	
3/4	589630	8,816	10.2	5.9	3.5	.75	4.3	2.4	.55	3.1
7/8	589631	14,105	11.8	6.3	3.7	.87	5.5	3.2	.67	6.2
1	589632	14,720	13.4	7.5	4.3	.98	5.9	3.5	.75	7.0
1-1/4	589633	28,211	14.2	7.9	4.7	1.2	6.3	3.7	.87	13.0
1-5/8	589634	52,896	16.9	9.9	5.9	1.6	7.1	4.1	1.1	29.0
2	589635	70,528	19.7	11.8	7.9	2.0	7.9	4.3	1.3	51.0
2-1/4	589636	88,160	22.0	11.8	7.9	2.2	10.2	5.5	1.5	70.0
2-1/2	589637	132,240	24.0	13.8	7.9	2.4	10.2	5.5	1.8	100.0
2-3/4	589638	176,320	26.8	15.8	9.9	2.8	11.0	6.3	2.0	150.0
3-1/4	589639	220,400	26.8	15.8	9.9	3.1	11.0	6.3	2.2	190.0

PIPE CARRIER SLINGS

Pipe Carrier Slings

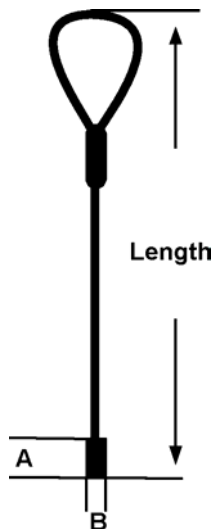

PIPE CARRIER LIFTING SLING SPECIFICATIONS				
Model Number	Wire Rope Dia.	Length	After Swage Dimensions, In.	
			LS-3/4	3/4"
LS-7/8	7/8"	5'-0" STD	7.72	1.80
LS-1	1"	5'-0" STD	8.72	2.05
LS-1-1/8	1-1/8"	5'-0" STD	9.62	2.30
LS-1-1/4	1-1/4"	5'-0" STD	10.84	2.56
LS-1-1/2	1-1/2"	5'-0" STD	13.04	3.00

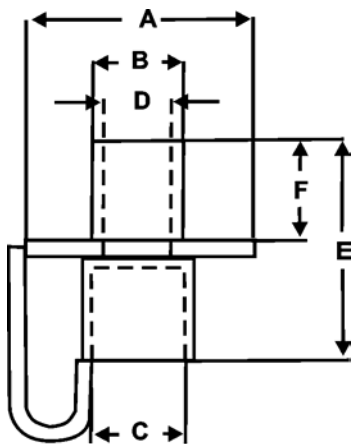

TEA CUP PIPE CARRIER SPECIFICATIONS									
Model Number	Use with Cable	Rated Capacity in Tons	DIMENENSIONS (INS.)						
			A	B	C	D	E	F	G
PC-3/4	3/4" 7/8"	4.9	5-9/16	2	2-1/8	1-1/8	4-11/16	1-7/8	1-1/8
PC-1	1" 1-1/8" 1-1/4"	8.5	6	2-1/2	2-5/8	1-3/8	5-5/8	2	1-3/8
PC-1-1/2"	1-1/2"	15.0	8	3	3-1/4	1-5/8	7-5/8	3	1-5/8

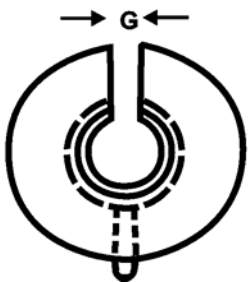

THREADED STUDS

Threaded Studs

For additional engineering, contact LiftPRO

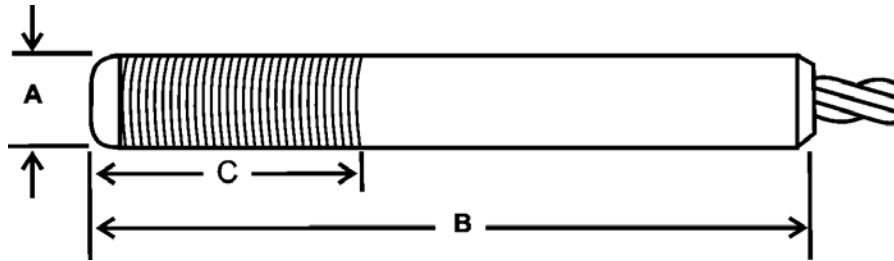

Item Number	Rope Dia.	A	B Approx.	C	Size	NC	NF	Weight
430-TTS-8-A	1/4"	1/2"	4-23/32	1-1/2"	1/2"	13	20	.213 lb.
430-TTS-B	1/4"	9/16"	4-23/32	1-1/2"	9/16"	12	18	.281 lb.
430-TTS-10	5/16"	5/8"	5-23/32	1-3/4"	5/8"	11	18	.413 lb.
430-TTS-12	3/8"	3/4"	6-3/4	2"	3/4"	10	16	.719 lb.
430-TTS-14	7/16"	7/8"	7-21/32	2-1/4"	7/8"	9	14	1.125 lb.
430-TTS-16	1/2"	1"	8-9/16	2-1/2"	1"	8	14	1.644 lb.
430-TTS-18	9/16"	1-1/8"	9-5/8	2-3/4"	1-1/8"	7	12	2.325 lb.
430-TTS-20	5/8"	1-1/4"	10-21/32	3-1/8"	1-1/4"	7	12	3.231 lb.
430-TTS-24	3/4"	1-1/2"	12-11/16	3-3/4"	1-1/2"	6	12	5.513 lb.
430-TTS-28	7/8"	1-3/4"	14-5/8	4-3/8"	1-3/4"	5	12	8.575 lb.
430-TTS-32	1"	2"	16-21/32	5"	2"	4-1/2	12	12.600 lb.
430-TTS-36	1-1/8"	2-1/4"	18-5/8	5-5/8"	2-1/4"	4-1/2	12	18.000 lb.
430-TTS-40	1-1/4"	2-1/2"	20-21/32	6-1/4"	2-1/2"	4	12	24.687 lb.
430-TTS-44	1-3/8"	2-3/4"	22-17/32	6-7/8"	2-3/4"	4	12	33.062 lb.
430-TTS-48	1-1/2"	3"	24-1/2	7-1/2"	3"	4	12	49.300 lb.

THREADED STUDS AFTER SWAGE

Threaded Studs After Swage

For additional engineering, contact LiftPRO

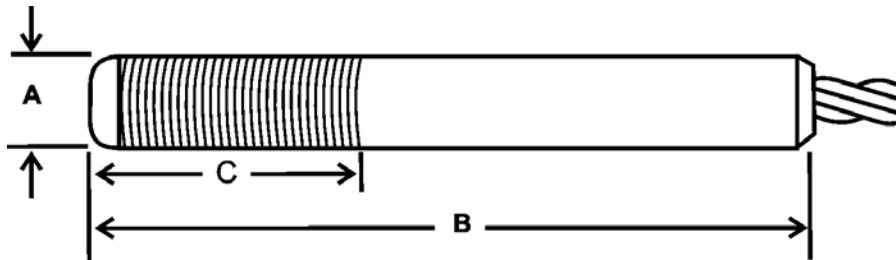

Item Number	Rope Dia.	A—After Swage	B	C	NC Thd	NF Thd	Weight
430-ST5-4	1/8"	7/32"	2-3/8"	1"	1/4-20	1/4-28	.025 LB.
430-ST5-6	3/16"	5/16"	3"	1-1/8"	3/8-16	3/8-24	.069 LB.
430-ST5-8	1/4"	7/16"	4-1/16"	1-1/2"	1/2-13	1/2-20	.162 LB.
430-ST5-10	5/16"	9/16"	5-1/16"	1-7/8"	5/8-11	5/8-18	.331 LB.
430-ST5-12	3/8"	5/8"	6-1/4"	2-1/4"	3/4-10	3/4-16	.575 LB.
430-ST5-14	7/16"	3/4"	7-5/16"	2-5/8"	7/8-9	7/8-14	.900 LB.
430-ST5-16	1/2"	7/8"	8-1/4"	3"	1-8	1-14	1.362 LB.
430-ST5-18	9/16"	1"	9-1/4"	3-3/8"	1-1/8-7	1-1/8-12	1.931 LB.
430-ST5-20	5/8"	1-1/8"	10-1/8"	3-3/4"	1-1/4-7	1-1/4-12	2.662 LB.
430-ST5-24	3/4"	1-1/4"	12-13/16"	4-1/2"	1-1/2-6	1-1/2-12	4.556 LB.
430-ST5-28	7/8"	1-1/2"	14-9/16"	5-1/4"	1-3/4-5	1-3/4-12	7.137 LB.
430-ST5-32	1"	1-3/4"	16-1/4"	6"	2-4-1/2	2-12	10.662 LB.
430-ST5-36	1-1/8"	2"	18-1/4"	6-3/4"	2-1/4-4-1/2	2-1/4-12	15.625 LB.
430-ST5-40	1-1/4"	2-1/4"	20-1/4"	7-1/2"	2-1/2-4	2-1/2-12	21.000 LB.
430-ST5-44	1-3/8"	2-3/8"	22-7/8"	8-1/4"	2-3/4-4	2-3/4-12	30.500 LB.
430-ST5-48	1-1/2"	2-5/8"	24-3/4"	9"	3-4	3-12	41.100 LB.

SWAGED SOCKET/BOOM PENDANT ASSEMBLIES

Boom Pendants with Swaged Fittings

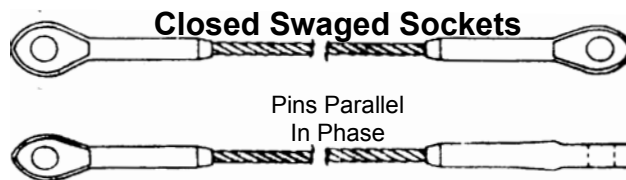
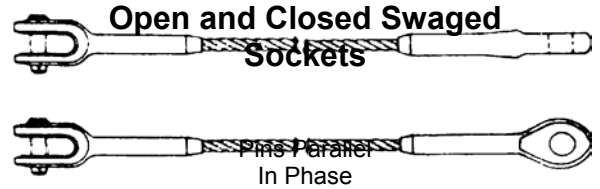
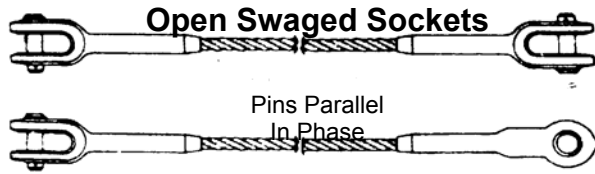

RATED CAPACITIES IN TONS OF 2,000 LBS. 6 X 19 & 6 X 37 IWRC Improved Plow Steel*				
Rope Dia. in Inches	Min. Length (SL) of Pendant ft-inches	Single Part Vertical		
		IPS	EIPS	EEIPS
1/4"	0-11	0.59	0.68	0.74
3/8"	1-3	1.3	1.5	1.7
1/2"	1-8	2.3	2.7	2.9
5/8"	2-0	3.6	4.1	4.5
3/4"	2-5	5.1	5.9	6.5
7/8"	2-10	6.9	8.0	8.8
1"	3-2	9.0	10	11
1 1/8"	3-7	11	13	14
1 1/4"	4-0	14	16	18
1 3/8"	4-5	17	19	21
1 1/2"	4-9	20	23	25
1 3/4"	5-5	27	31	34
2"	6-4	34	40	43

* Values given apply when pendants are used as slings or sling assemblies. When used in a Boom suspension system, other values apply; consult rope manufacturer.

SWAGED SOCKET/BOOM PENDANT ASSEMBLIES

Boom Pendants with Swaged Fittings

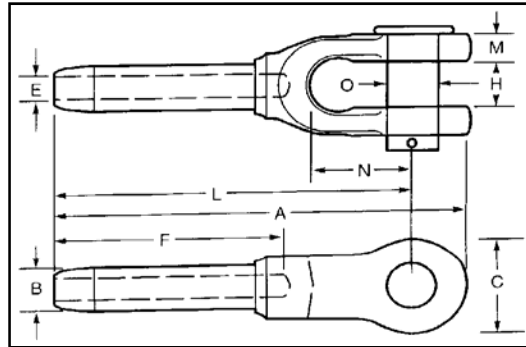

OPEN FORGED WAGE SOCKETS

OPEN SWAGE SOCKETS												
Rope Dia.	Item No.	A	C	E	F	H	L	M	N	O	Weight Each	Size
1/4"	40025002	4 3/4"	1 3/8"	0.272"	2 1/8"	11/16"	4"	3/8"	1 1/2"	11/16"	0.6 lb.	1/4"
5/16"	40031302	6 3/16"	1 9/16"	0.339"	3 3/16"	13/16"	5 5/16"	15/32"	1 3/4"	13/16"	1.2 lbs.	5/16"
3/8"	40037502	6 3/16"	1 9/16"	0.406"	3 3/16"	1 13/16"	5 5/16"	15/32"	1 3/4"	13/16"	1.3 lbs.	3/8"
7/16"	40043802	7 3/4"	1 15/16"	0.484"	4 1/4"	1"	6 11/16"	9/16"	2"	1"	2.2 lbs.	7/16"
1/2"	40050002	7 3/4"	1 15/16"	0.547"	4 1/4"	1"	6 11/16"	9/16"	2"	1"	2.2 lbs.	1/2"
9/16"	40053602	9 7/16"	2 3/8"	0.609"	5 5/16"	1 1/4"	8 1/8"	21/32"	2 1/4"	1 3/16"	4.7 lbs.	9/16"
5/8"	40062502	9 7/16"	2 3/8"	0.672"	5 5/16"	1 1/4"	8 1/8"	21/32"	2 1/4"	1 3/16"	5.0 lbs.	5/8"
3/4"	40075002	11 5/8"	3"	0.796"	6 3/8"	1 1/2"	10"	25/32"	2 3/4"	1 3/8"	8.4 lbs.	3/4"
7/8"	40087502	13 1/2"	3 1/2"	0.938"	7 7/16"	1 3/4"	11 5/8"	15/16"	3 1/4"	1 5/8"	11.9 lbs.	7/8"
1"	40100002	15 1/2"	4"	1.062"	8 1/2"	2"	13 3/8"	1"	3 3/4"	2"	18.7 lbs.	1"
1 1/8"	40112502	17 7/16"	4 1/2"	1.188"	9 9/16"	2 1/4"	15"	1 3/16"	4 3/4"	2 1/4"	28.9 lbs.	1 1/8"
1 1/4"	40125002	19 3/16"	5"	1.328"	10 5/8"	2 1/2"	16 1/2"	1 3/16"	4 3/4"	2 1/2"	37. bs.	1 1/4"
1 3/8"	40137502	21 1/16"	5 1/8"	1.453"	11 11/16"	2 1/2"	18 1/8"	1 5/16"	5 1/4"	2 1/2"	49.1 lbs.	1 3/8"
1 1/2"	40150002	23"	6 1/2"	1.578"	12 3/4"	3"	19 3/4"	1 7/16"	5 3/4"	2 3/4"	62.7 lbs.	1 1/2"
1 3/4"	40175002	26 3/4"	6 1/2"	1.860"	14 7/8"	3 1/2"	23"	1 11/16"	6 3/4"	3 1/2"	93.2 lbs.	1 3/4"
2"	40200002	31 5/16"	8"	2.109"	17"	4"	26 7/8"	1 7/8"	8"	3 3/4"	153.6 lbs.	2"

SWAGED SOCKET/BOOM PENDANT ASSEMBLIES

Boom Pendants with Swaged Fittings

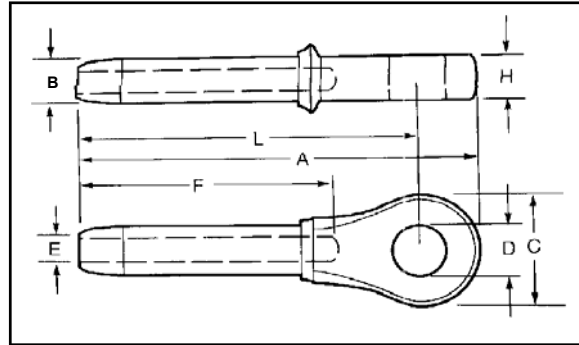

CLOSED FORGED SWAGE SOCKETS

CLOSED SWAGE SOCKETS												
Rope Dia.	Item No.	A	B	C	D	E	F	H	L	B2	Weight Each	Size
1/4"	41025002	4 3/8"	0.495"	1 7/16"	0.750"	0.272"	2 1/8"	1/2"	3 1/2"	0.438	0.4 lb.	1/4"
5/16"	41031302	5 1/2"	0.770"	1 11/16"	0.875"	0.339"	3 3/16"	11/16"	4 1/2"	0.688	0.8 lbs.	5/16"
3/8"	41037502	5 1/2"	0.770"	1 11/16"	0.875"	0.406"	3 3/16"	11/16"	4 1/2"	0.688	0.8 lbs.	3/8"
7/16"	41043802	6 7/8"	0.982"	2"	1.063"	0.484"	4 1/4"	7/8"	5 3/4"	0.875	1.5 lbs.	7/16"
1/2"	41050002	6 7/8"	0.982"	2"	1.063"	0.547"	4 1/4"	7/8"	5 3/4"	0.875	1.4 lbs.	1/2"
9/16"	41053602	8 5/8"	1.257"	2 1/2"	1.250"	0.609"	5 5/16"	1 1/8"	7 1/4"	1.125	3.1 lbs.	9/16"
5/8"	41062502	8 5/8"	1.257"	2 1/2"	1.250"	0.672"	5 5/16"	1 1/8"	7 1/4"	1.125	3.0 lbs.	5/8"
3/4"	41075002	10 3/16"	1.545"	3"	1.437"	0.796"	6 3/8"	1 5/16"	8 5/8"	1.375	5.2 lbs.	3/4"
7/8"	41087502	11 7/8"	1.700"	3 3/16"	1.687"	0.938"	7 7/16"	1 1/2"	10 1/8"	1.500	7.0 lbs.	7/8"
1"	41100002	13 9/16"	1.975"	3 13/16"	2.062"	1.062"	8 1/2"	1 3/4"	11 1/5"	.750	10.8 lbs.	1"
1 1/8"	41112502	15 1/16"	2.245"	4 1/4"	2.312"	1.188"	9 9/16"	2"	12 3/4"	2.000	15.2 lbs.	1 1/8"
1 1/4"	41125002	16 15/16"	2.525"	4 5/8"	2.562"	1.328"	10 5/8"	2 1/4"	14 3/8"	2.250	21.8 bs.	1 1/4"
1 3/8"	41137502	18 5/8"	2.800"	5"	2.562"	1.453"	11 11/16"	2 1/4"	15 3/4"	2.500	29.3 lbs.	1 3/8"
1 1/2"	41150002	20 1/8"	3.075"	5 1/2"	2.812	1.578"	12 3/4"	2 1/2"	17"	2.750	37.8 lbs.	1 1/2"
1 3/4"	41175002	23 9/16"	3.385"	6 1/2"	3.562"	1.860"	14 7/8"	3"	20"	3.000	53.6 lbs.	1 3/4"
2"	41200002	27 5/16"	3.94"	7 3/4"	3.812"	2.109"	7"	3 1/4"	23"	3.500	93.7 lbs.	2"

SPECIAL BOOM PENDANT ASSEMBLIES

Special Boom Pendant Assemblies

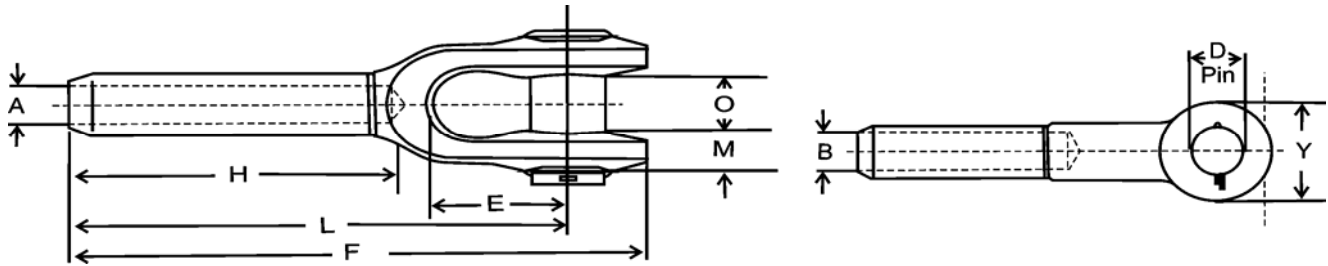

SPECIAL OPEN SWAGE SOCKETS

Rope Dia.	Item No.	A	B	D	E	F	H	L	M	O	Y	Weight Each	A/S In. Min. Max.
1-1/8"	40100010	1.975	1.188	2.000	3.750	15.625	8.500	13.375	1.031	2.000	4.000	12.69	1.740-1.800
1-1/4"	40112510	2.245	1.328	2.250	4.250	17.500	9.563	15.000	1.188	2.250	4.500	19.35	1.990-2.050
1-3/8"	40125010	2.525	1.453	2.500	4.750	19.438	10.625	16.500	1.188	2.500	5.000	26.38	2.240-2.300
1-1/2"	40137510	2.800	1.578	2.500	5.250	21.250	11.688	18.125	1.313	2.500	5.250	38.00	2.490-2.560
1-3/4"	40150010	3.075	1.859	2.750	5.750	23.250	12.750	19.750	1.438	3.000	5.500	48.83	2.740-2.810

SPECIAL BOOM PENDANT ASSEMBLIES

Special Boom Pendant Assemblies

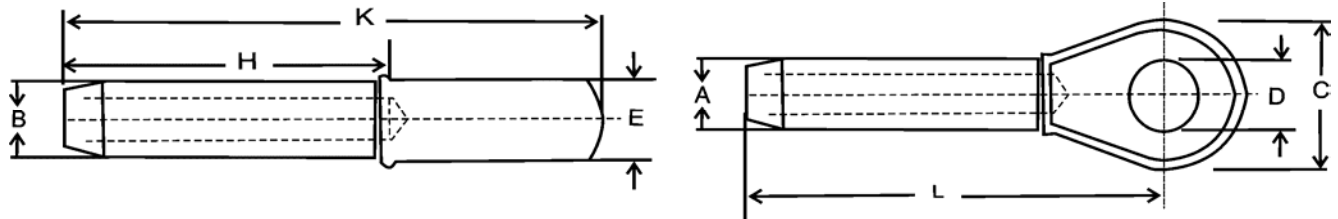

SPECIAL CLOSED SWAGE SOCKETS											
Rope Dia.	Item No.	A	B	C	D	E	H	K	L	Weight Each lbs.	A/S In. Min. Max.
1-1/8"	41100010	1.975	1.188	4.000	2.063	1.750	8.500	13.750	11.500	11.00	1.740-1.800
1-1/4"	41112510	2.245	1.328	4.500	2.313	2.000	9.563	15.250	12.750	15.21	1.990-2.050
1-3/8"	41125010	2.525	1.453	5.000	2.563	2.250	10.625	17.250	14.375	22.25	2.240-2.300
1-1/2"	41137510	2.800	1.578	5.250	2.563	2.250	11.688	18.875	15.750	28.16	2.490-2.560
1-3/4"	41150010	3.075	1.859	5.500	2.813	2.500	12.750	20.375	17.000	34.65	2.740-2.810

OPEN BRIDGE BOWL SOCKETS

Open Bridge Bowl Sockets

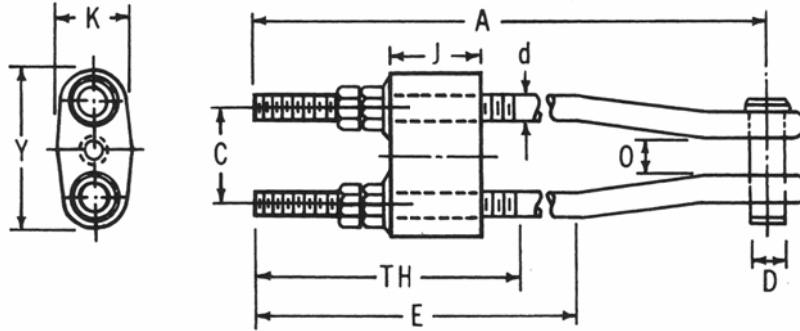

OPEN BRIDGE BOWL SOCKETS																				
Rope Dia.	DIMENSIONS IN INCHES																Weight Lb.		Strand Dia. Inches Size	
	Stock No.	Std. Take-Up	A	A	C	d	D	E	E	J	K	O	P	TH	TH	Y	Cotter Pin Dia.	Std. Take-Up		48" Take-Up
			For Std. Take-Up	For 48" Take-Up					For Std. Take-Up	For 48" Take-Up				Pin Length	For Std. Take-Up	For 48" Take-Up				
1-5/8 1-3/4	F-4481-O	15	39	72	8-1/8	2	3-1/2	27	60	7-5/16	6-1/2	3-1/2	8-1/2	19-1/4	52-1/4	11-3/4	1/2	180	239	1-7/16 1-1/2
1-7/8 2	F-4482-O	15	42	75	9	2-1/4	3-3/4	28-1/2	61-1/2	8-1/8	7-5/16	4	9-5/8	19-3/4	52-3/4	13-1/8	1/2	249	323	1-9/16 1-3/4
2-1/8 2-1/4	F-4483-O	18	50	80	10-1/4	2-1/2	4-1/4	33	63	9-5/16	8-1/8	4-1/2	10-5/8	23-1/4	53-1/4	14-3/4	1/2	356	439	1-13/16 2
2-3/8 2-1/2	F-4484-O	18	52	82	11-1/2	2-3/4	4-3/4	35-1/2	65-1/2	10-7/8	8-15/16	5	11-3/4	23-3/4	53-3/4	16-1/2	5/8	485	586	2-1/16 2-1/4
2-5/8 2-3/4	F-4485-O	18	54	84	12-11/16	3	5	36-1/2	66-1/2	11-13/16	9-3/4	5-3/8	12-5/8	24-1/4	54-1/4	18-1/16	5/8	610	730	2-5/16 2-3/8
2-7/8 3	F-4486-O	21	59	86	13-3/8	3-1/4	5-3/4	41	68	12-13/16	10-9/16	6	13-3/4	27-3/4	54-3/4	19-1/4	5/8	776	903	2-7/16 2-5/8
3-1/4	F-4487-O	21	61	88	14-1/16	3-1/2	5-3/4	42-1/2	69-1/2	13-9/16	11-3/8	6-1/4	14-1/2	28-1/4	55-1/4	20-5/16	5/8	882	1030	2-11/16 2-3/4
3-1/2	F-4488-O	21	63	90	15-1/4	3-3/4	6-1/4	45	72	15-1/2	12-3/16	7-1/2	16-3/8	28-3/4	55-3/4	22	5/8	1180	1349	2-7/8 3
3-3/4	F-4489-O	24	70	94	17-1/4	4	7	50	74	17-1/8	13	7-3/4	17	32-1/4	56-1/4	24-1/2	5/8	1508	1679	3-1/8 3-1/4
(none)	F-4490-O	24	75	99	18-5/16	4-1/4	7-1/4	53	77	19-5/16	13-13/16	8	17-7/8	32-3/4	56-3/4	26-1/16	3/4	1621	1821	3-3/8 3-1/2
4	F-4491-O	24	80	104	19-3/8	4-1/2	7-1/2	55-1/2	79-1/2	21-1/8	14-5/8	8-1/4	18-5/8	33-1/4	57-1/4	27-5/8	3/4	2031	2251	3-5/8 3-3/4
4-1/4	F-4492-O	24	85	109	20-7/16	4-3/4	7-3/4	57-1/2	81-1/2	22-15/16	15-7/16	8-1/2	19-3/8	33-3/4	57-3/4	29-7/16	3/4	2444	2684	3-7/8 4
4-1/2 4-3/4	F-4755-O	27	87	108	20	4-1/4	7-1/4	59-1/2	80-1/2	20	14	8-1/4	18-1/4	36	57	28	3/4	2311	2480	4-1/8 4-3/8
5 5-1/4	F-4756-O	27	90	111	21	4-3/4	7-1/2	62	83	21-1/4	14-7/8	8-1/2	19-1/2	37	58	30-1/4	3/4	2917	3129	4-1/2 4-3/4
5-1/2 5-3/4	F-4757-O	30	96	114	22	5	8	67	85	22-3/4	16	8-3/4	20-1/4	40-1/2	58-1/2	31-1/2	3/4	3427	3627	4-7/8 5-1/8
6	F-4758-O	30	99	117	23	5-1/2	8-1/2	69-1/2	87-1/2	24-1/2	17	9	21-1/2	41-1/2	59-1/2	33	3/4	4166	4408	5-1/4 5-1/2

OPEN BRIDGE BOWL SOCKETS

Open Bridge Bowl Sockets

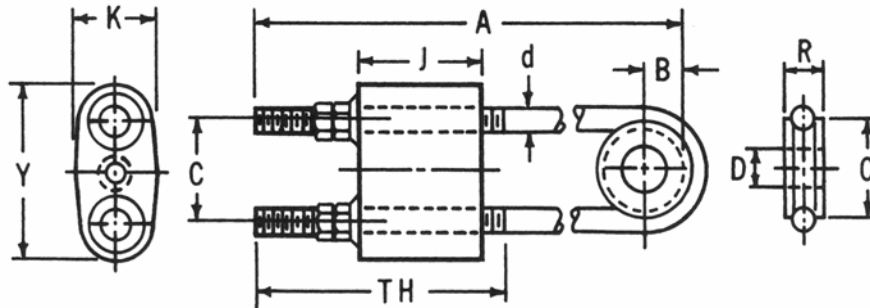

OPEN BRIDGE BOWL SOCKETS																	
Rope Dia.	DIMENSIONS IN INCHES														Weight Lb.		Strand Dia. Inches Size
	Stock No.	Std. Take-Up	A	A	B	C	d	D	J	K	R	TH	TH	Y	Std. Take-Up	48" Take-Up	
			For Std. Take-Up	For 48" Take-Up									For Std. Take-Up	For 48" Take-Up			
1-5/8 1-3/4	F-4481-C	15	34	67	2-27/32	8-1/8	2	3-9/16	7-5/16	6-1/2	2-9/16	19-1/4	52-1/4	11-3/4	170	229	1-7/16 1-1/2
1-7/8 2	F-4482-C	15	36	69	3-5/32	9	2-1/4	3-13/16	8-1/8	7-5/16	2-13/16	19-3/4	52-3/4	13-1/8	234	309	1-9/16 1-3/4
2-1/8 2-1/4	F-4483-C	18	42	72	3-21/32	10-1/4	2-1/2	4-9/16	9-5/16	8-1/8	3-1/16	23-1/4	53-1/4	14-3/4	333	416	1-13/16 2
2-3/8 2-1/2	F-4484-C	18	45	75	4-5/32	11-1/2	2-3/4	4-13/16	10-7/8	8-15/16	3-5/16	23-3/4	53-3/4	16-1/2	460	561	2-1/16 2-1/4
2-5/8 2-3/4	F-4485-C	18	48	78	4-5/8	12-11/16	3	5-1/16	11-13/16	9-3/4	3-11/16	24-1/4	54-1/4	18-1/16	597	717	2-5/16 2-3/8
2-7/8 3	F-4486-C	21	53	80	4-27/32	13-3/8	3-1/4	5-13/16	12-13/16	10-9/16	3-15/16	27-3/4	54-3/4	9-1/4	737	864	2-7/16 2-5/8
3-1/4	F-4487-C	21	55	82	5-1/16	14-1/16	3-1/2	5-13/16	13-9/16	11-3/8	4-3/16	28-1/4	55-1/4	20-5/16	855	1003	2-11/16 2-3/4
3-1/2	F-4488-C	21	58	85	5-17/32	15-1/4	3-3/4	6-13/16	15-1/2	12-3/16	4-1/2	28-3/4	55-3/4	22	1124	1293	2-7/8 3
3-3/4	F-4489-C	24	65	89	6-1/8	17-1/4	4	7-1/6	17-1/8	13	4-3/4	32-1/4	56-1/4	24-1/2	1493	1664	3-1/8 3-1/4
(none)	F-4490-C	24	69	93	6-29/32	18-5/16	4-1/4	7-5/16	19-5/16	13-13/16	5	32-3/4	56-3/4	26-1/16	1617	1810	3-3/8 3-1/2
4	F-4491-C	24	72	96	7-5/16	19-3/8	4-1/2	7-9/16	21-1/8	14-5/8	5-1/4	33-1/4	57-1/4	27-5/8	2079	2295	3-5/8 3-3/4
4-1/4	F-4492-C	24	75	99	7-23/32	20-7/16	4-3/4	7-13/16	22-15/16	15-7/16	5-1/2	33-3/4	57-3/4	29-7/16	2501	2742	3-7/8 4
4-1/2 4-3/4	F-4755-C	27	78	99	7-21/32	20	4-1/4	7-5/16	20	14	5	36	57	28	2172	2340	4-1/8 4-3/8
5 5-1/4	F-4756-C	27	81	102	7-29/32	21	4-3/4	7-9/16	21-1/4	14-7/8	5-1/2	37	58	30-1/4	2757	2968	4-1/2 4-3/4
5-1/2 5-3/4	F-4757-C	30	87	105	8-9/32	22	5	8-1/16	22-3/4	16	5-3/4	40-1/2	58-1/2	31-1/2	3215	3415	4-7/8 5-1/8
6	F-4758-C	30	91	109	8-17/32	23	5-1/2	8-9/16	24-1/2	17	6-1/4	41-1/2	59-1/2	33	3907	4149	5-1/4 5-1/2

LIFTING CLAMPS

Model S Lifting Clamp

A vertical lifting clamp that is an effective tool for construction and erection. It incorporates a "Lock Open," "Lock Closed" feature which facilitates attaching and removing the clamp from the plate.

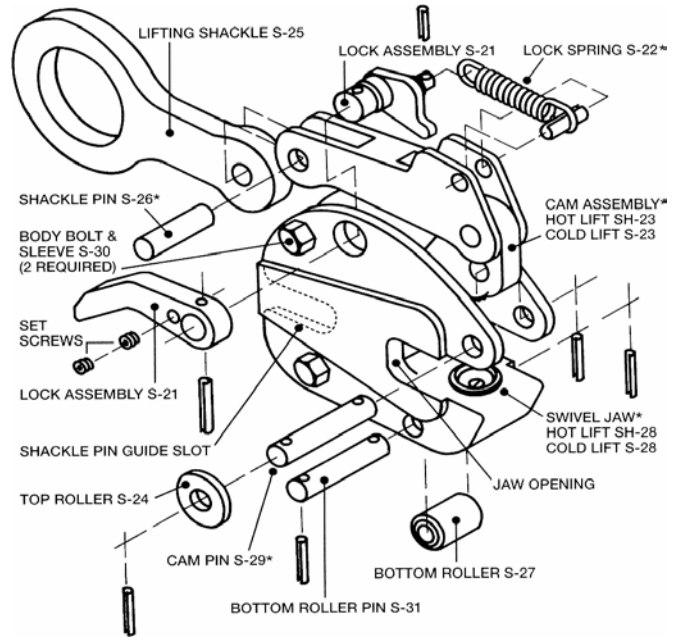
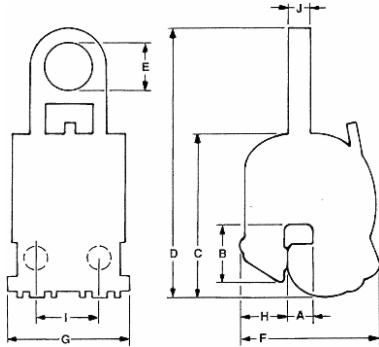

MODEL S LIFTING CLAMP

Rated Capacity In Tons	Plate Thickness A	B	C	Max. D	E	F	G	H	J	Weight in Lbs.
1/2	0-5/8	2	5-1/16	7-1/2	1-1/8	4-1/4	2-1/8	1-1/4	3/8	4
1	0-3/4	2	5-1/8	7-3/4	1-1/8	4-3/8	2-3/16	1-3/8	1/2	5
2	0-1	3-7/16	10	17	3-5/8	8-1/2	3-13/16	2-3/4	3/4	32
	3/4-1-1/2	3-7/16	10	17	3-5/8	9	3-13/16	2-3/4	3/4	33
	1-1/4-2	3-7/16	10	17	3-5/8	9-1/2	3-13/16	2-3/4	3/4	33
	1-3/4-2-1/2	3-7/16	10	17	3-5/8	10	3-13/16	2-3/4	3/4	36
4	0-1-1/4	4-5/8	11-1/2	19-5/8	3-5/8	10	4-7/8	3-7/16	3/4	41
	1-2	4-5/8	11-1/2	19-5/8	3-5/8	10-3/4	4-7/8	3-7/16	3/4	43
	1-3/4-2-3/4	4-5/8	11-1/2	19-5/8	3-5/8	11-1/2	4-7/8	3-7/16	3/4	43
	2-1/4-3-1/2	4-5/8	11-1/2	19-5/8	3-5/8	12-1/4	4-7/8	3-7/16	3/4	52
	3-1/4-4-1/4	4-5/8	11-1/2	19-5/8	3-5/8	13	4-7/8	3-7/16	3/4	60
8	0-1-1/2	4-1/2	13-15/16	22-1/2	3-3/4	10-1/2	5-1/8	3-5/16	1	70
	1-2	4-1/2	13-15/16	22-1/2	3-3/4	11	5-1/8	3-5/16	1	73
	2-3	4-1/2	13-15/16	22-1/2	3-3/4	12	5-1/8	3-5/16	1	77
	2-3/4-4	4-1/2	13-15/16	22-1/2	3-3/4	13	5-1/8	3-5/16	1	81
	3-3/4-5	4-1/2	13-15/16	22-1/2	3-3/4	14	5-1/8	3-5/16	1	85
12	0-2-1/2	6-1/2	18	28	3-7/8	13-1/2	6-1/4	3-7/8	1-3/4	140
	1/2-3	6-1/2	18	28	3-7/8	14	6-1/4	3-7/8	1-3/4	140
	2-4	6-1/2	18	28	3-7/8	15	6-1/4	3-7/8	1-3/4	143
	4-6	6-1/2	18	28	3-7/8	17	6-1/4	3-7/8	1-3/4	150
	5-1/2-7-1/2	6-1/2	18	28	3-7/8	18-1/2	6-1/4	3-7/8	1-3/4	160
20	1/2-3	7-1/2	22-3/4	35	4-15/16	17	7-3/8	5	2-1/2	265
	3-5	7-1/2	22-3/4	35	4-15/16	19	7-3/8	5	2-1/2	294
	5-7	7-1/2	22-3/4	35	4-15/16	21	7-3/8	5	2-1/2	324
	7-9	7-1/2	22-3/4	35	4-15/16	23	7-3/8	5	2-1/2	350

LIFTING CLAMPS

Model SD Lifting Clamp

A vertical lifting clamp that incorporates two Model S clamps into one and is used for heavy duty work when it is desirable to spread the gripping surfaces with two points of contact. It incorporates a "Lock Open," "Lock Closed" feature which facilitates attaching and removing the clamp from the plate.

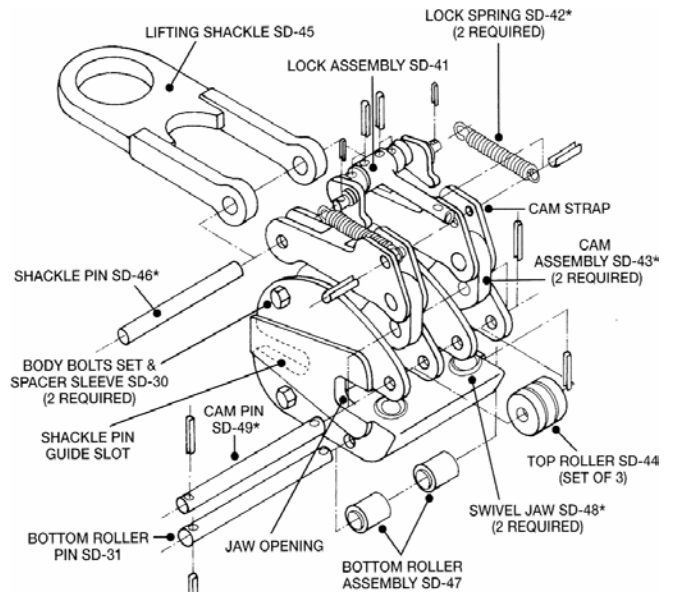
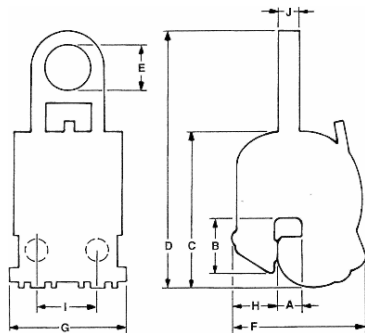

MODEL SD LIFTING CLAMP										
Rated Capacity In Tons	Plate Thickness A	B	C	D	E	F	G	H	J	Weight in Lbs.
6	0-1	3-1/4	9-1/2	15-1/2	3	7-1/2	2-1/8	4-1/8	3/4	60
	3/4-1-1/2	3-1/4	9-1/2	15-1/2	3	8	2-1/8	4-1/8	3/4	62
8	4-1/2	4-1/2	11-1/2	17	3	8-3/4	3	4-1/4	1	77
	4-1/2	4-1/2	11-1/2	17	3	9-1/2	3	4-1/4	1	81

LIFTING CLAMPS

Model TL & TLA Lifting Clamp

Model TLA is a vertical lifting clamp that incorporating a "Lock Open," "Lock Closed" feature and an auxiliary lock. The clamp is capable of turning a steel plate from horizontal to vertical and back to horizontal through a 180 degree arc. The "Lock Open" and "Lock Closed" feature facilitates attaching and removing the clamp from the plate.

Model TL is identical to TLA except that it does not contain the auxiliary lock. The Model TL is capable of turning a plate from horizontal to vertical and back to horizontal through the same 90 degree arc.

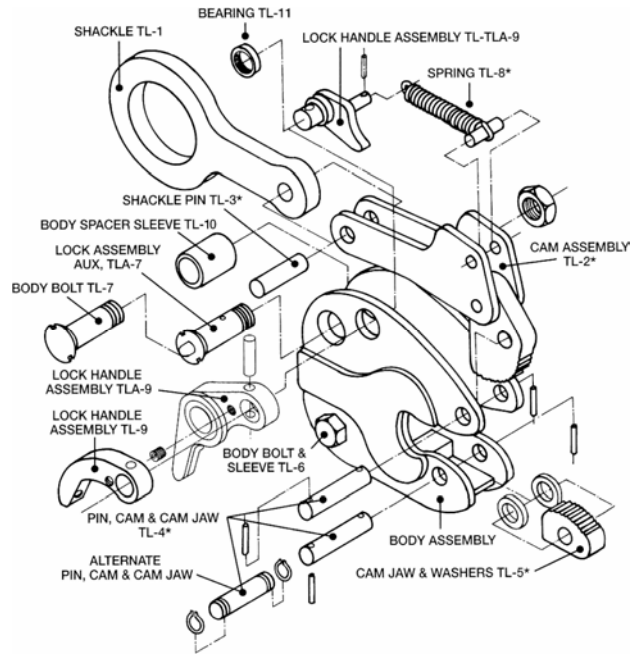
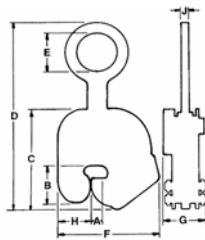

MODEL TL & TLA LIFTING CLAMP

Rated Capacity In Tons	Plate Thickness A	B	C	Max. D	E	Max. F	G	H	J	Weight in Lbs.
1/2	0-5/8	2-3/8	6-1/4	11-1/8	2-3/8	4-3/4	2-3/4	1-13/16	1/2	9
	1/2-1	2-3/8	6-1/4	11-1/8	2-3/8	5-1/8	2-3/4	1-13/16	1/2	10
	3/4-1-1/4	2-3/8	6-1/4	11-1/8	2-3/8	5-3/8	2-3/4	1-13/16	1/2	11
	1-1/4-1-3/4	2-3/8	6-1/4	11-1/8	2-3/8	5-7/8	2-3/4	1-13/16	1/2	13
1	0-3/4	3	7-1/2	13-1/8	2-5/8	6	2-13/16	2	5/8	14
	1/2-1	3	7-1/2	13-1/8	2-5/8	6-1/4	2-13/16	2	5/8	15
	3/4-1-1/4	3	7-1/2	13-1/8	2-5/8	6-1/2	2-13/16	2	5/8	16
	1-1-1/2	3	7-1/2	13-1/8	2-5/8	6-3/4	2-13/16	2	5/8	17
	1-1/2-2	3	7-1/2	13-1/8	2-5/8	7-1/4	2-13/16	2	5/8	18
2	0-1	3-1/2	9-3/8	16-1/4	3-5/8	8-7/8	3-3/4	2-7/8	3/4	32
	3/4-1-1/2	3-1/2	9-3/8	16-1/4	3-5/8	9-3/8	3-3/4	2-7/8	3/4	33
	1-1/4-2	3-1/2	9-3/8	16-1/4	3-5/8	9-7/8	3-3/4	2-7/8	3/4	36
	2-2-3/4	3-1/2	9-3/8	16-1/4	3-5/8	10-5/8	3-3/4	2-7/8	3/4	37
4	3/16-1-1/4	4	9-7/8	17-5/8	3-5/8	9	3-13/16	3	3/4	36
	1-2	4	9-7/8	17-5/8	3-5/8	9-3/4	3-13/16	3	3/4	37
	2-3	4	9-7/8	17-5/8	3-5/8	10-3/4	3-13/16	3	3/4	40
	3-4	4	9-7/8	17-5/8	3-5/8	11-3/4	3-13/16	3	3/4	43
6	1/4-1-3/8	4-5/8	11-1/8	20-1/8	3-1/2	10-1/4	3-7/8	3-3/8	3/4	49
	1-2-1/8	4-5/8	11-1/8	20-1/8	3-1/2	11	3-7/8	3-3/8	3/4	51
	2-3-1/8	4-5/8	11-1/8	20-1/8	3-1/2	12	3-7/8	3-3/8	3/4	54
	3-4-1/8	4-5/8	11-1/8	20-1/8	3-1/2	13	3-7/8	3-3/8	3/4	57
8	3/8-1-1/2	4-13/16	12-5/16	21-5/16	3-3/4	11-1/2	4-3/4	3-7/8	1	72
	1-2-1/8	4-13/16	12-5/16	21-5/16	3-3/4	12-1/8	4-3/4	3-7/8	1	74
	2-3-1/8	4-13/16	12-5/16	21-5/16	3-3/4	13-1/8	4-3/4	3-7/8	1	77
	3-4-1/8	4-13/16	12-5/16	21-5/16	3-3/4	14-1/8	4-3/4	3-7/8	1	80

LIFTING CLAMPS

Model LJ Lifting Clamp

A vertical lifting clamp capable of turning a plate from horizontal to vertical and back to horizontal through the same 90 degree arc. It is small and easy to handle in capacities through three tons. Incorporates the "Lock Closed" feature which facilitates attaching the clamp to the plate.

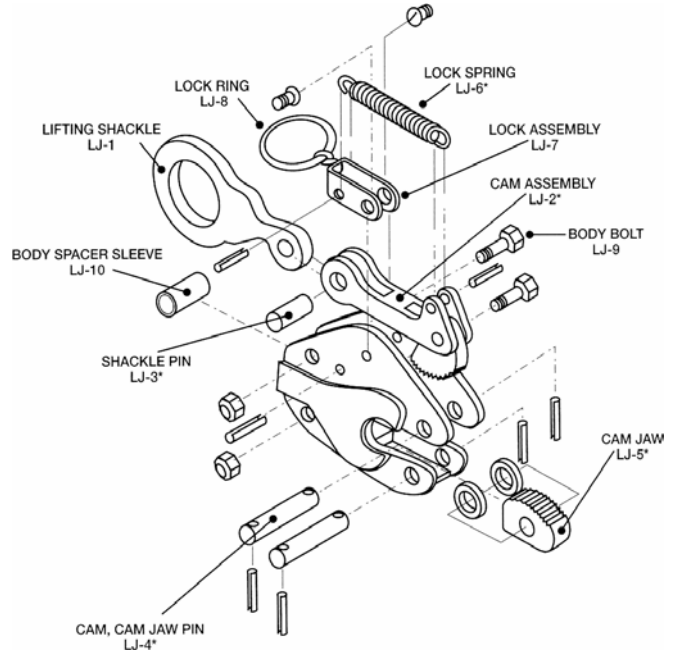
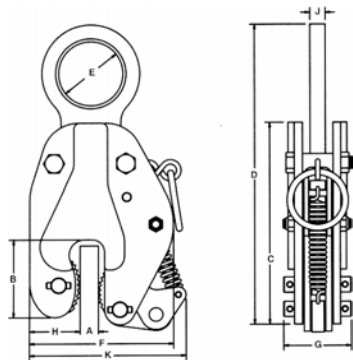

MODEL LJ LIFTING CLAMP											
Rated Capacity In Tons	Plate Thickness A	B	C	Max. D	E	F	G	H	J	Max. K	Weight in Lbs.
1/2	0-3/4	2-5/8	6-5/8	10-1/4	2-1/4	5	2-3/8	1-7/8	1/2	5	9
1	0-3/4	3-3/16	8-1/4	13-7/16	2-5/8	5-7/8	2-7/8	2-1/16	5/8	6-7/16	15
2	0-1	3-5/8	9	15-13/16	3-5/8	7-1/4	3-1/4	2-7/8	3/4	7-5/8	26
3	0-1-1/4	4-1/4	10-3/4	18	3-5/8	8-3/16	3-5/8	3	3/4	8-3/8	34

LIFTING CLAMPS

Model FR Lifting Clamp

A vertical lifting tool for relatively light work. It is small and easy to handle in capacities through three tons. Incorporates the "Lock Closed" feature which facilitates attaching the clamp to the plate.

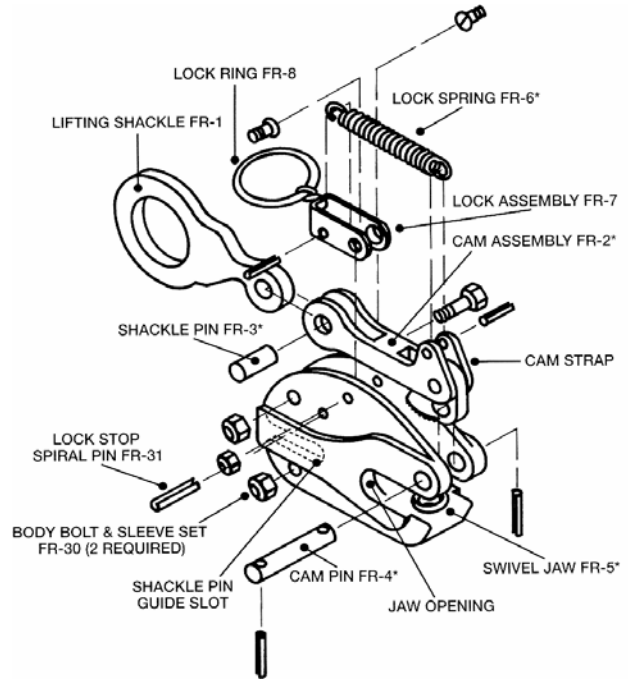
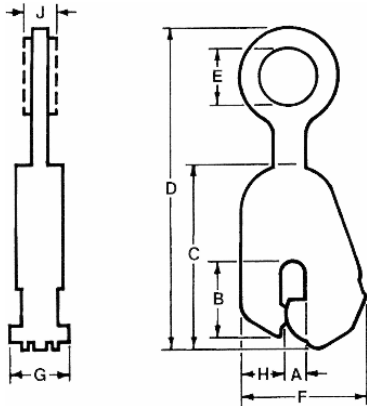

MODEL FR LIFTING CLAMP										
Rated Capacity In Tons	Plate Thickness A	B	C	Max. D	E	F	G	H	J	Weight in Lbs.
1/2	0-3/4	2-13/16	7	11-1/4	2-3/8	4-5/8	2-1/2	1-1/4	1/2	8
	1/2-1	2-13/16	7	11-1/4	2-3/8	4-7/8	2-1/2	1-3/8	1/2	8
	3/4-1-1/4	2-13/16	7	11-1/4	2-3/8	5-1/8	2-1/2	2-3/4	1/2	9
	1-1-1/2	2-13/16	7	11-1/4	2-3/8	5-3/8	2-1/2	2-3/4	1/2	10
	1-1/4-1-3/4	2-13/16	7	11-1/4	2-3/8	5-3/8	2-1/2	2-3/4	1/2	11
1	0-3/4	3-3/16	9	11-1/4	2-5/8	5-7/8	3-3/16	1-5/8	5/8	14
	1/2-1	3-3/16	9	13-3/4	2-5/8	6-1/8	3-3/16	1-5/8	5/8	15
	3/4-1-1/4	3-3/16	9	13-3/4	2-5/8	6-3/8	3-3/16	1-5/8	5/8	15
	1-1-1/2	3-3/16	9	13-3/4	2-5/8	6-5/8	3-3/16	1-5/8	5/8	16
	1-1/4-1-3/4	3-3/16	9	13-3/4	2-5/8	6-7/8	3-3/16	1-5/8	5/8	17
2	1-1/2-2	3-3/16	9	13-3/4	2-5/8	7-1/8	3-3/16	1-5/8	5/8	18
	0-1	3-1/2	9	16-3/8	3-5/8	6-3/4	3-3/8	2-1/8	3/4	23
	3/4-1-1/2	3-1/2	9	16-3/8	3-5/8	7-1/4	3-3/8	2-1/8	3/4	23
	1-1/4-2	3-1/2	9	16-3/8	3-5/8	7-3/4	3-3/8	2-1/8	3/4	23
	1-3/4-2-1/2	3-1/2	9	16-3/8	3-5/8	8-1/4	3-3/8	2-1/8	3/4	24
3	0-1-1/4	4-3/16	10-3/4	18-3/8	3-5/8	7-5/8	3-9/16	2-7/16	3/4	30
	3/4-1-1/2	4-3/16	10-3/4	18-3/8	3-5/8	7-7/8	3-9/16	2-7/16	3/4	31
	1-1/4-2	4-3/16	10-3/4	18-3/8	3-5/8	8-3/8	3-9/16	2-7/16	3/4	32
	1-3/4-2-1/2	4-3/16	10-3/4	18-3/8	3-5/8	8-7/8	3-9/16	2-7/16	3/4	33

LIFTING CLAMPS

Model J Lifting Clamp

A vertical lifting clamp capable of turning a single plate or member from horizontal to vertical and back to horizontal through the same 90 degree arc.

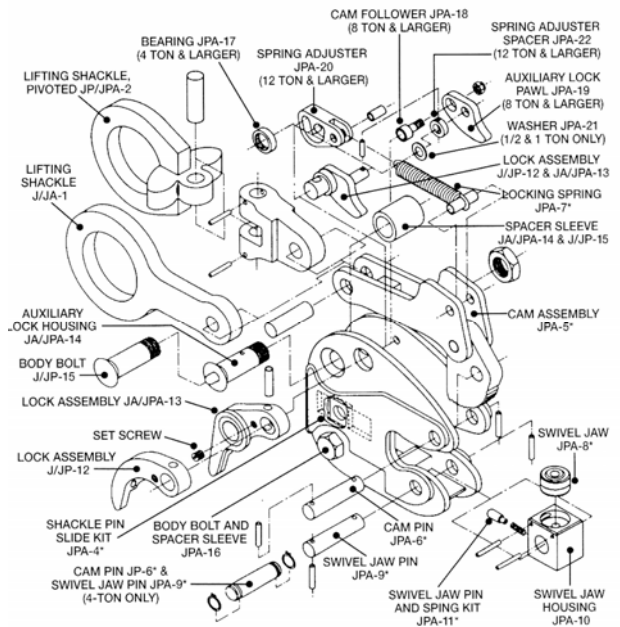
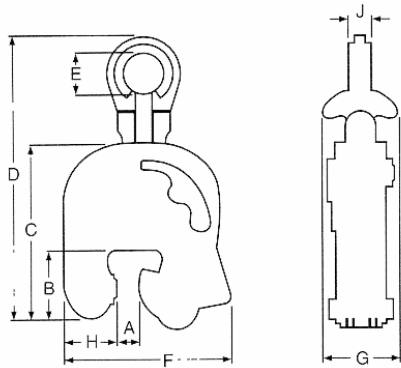

MODEL J LIFTING CLAMP										
Rated Capacity In Tons	Plate Thickness A	B	C	Max. D	E	F	G	H	J	Weight in Lbs.
1/2	0-5/8	2-3/4	6-1/2	12	2-3/8	5-5/8	3-1/4	2-1/4	1/2	10
	1/2-1	2-3/4	6-1/2	12	2-3/8	6	3-1/4	2-1/4	1/2	
	3/4-1-1/4	2-3/4	6-1/2	12	2-3/8	6-1/4	3-1/4	2-1/4	1/2	
1	1-1/4-1-3/4	2-3/4	6-1/2	12	2-3/8	6-3/4	3-1/4	2-1/4	1/2	
	0-3/4	3-3/8	7-3/4	13-3/4	2-5/8	7	3-1/2	2-5/8	5/8	15
	1/2-1	3-3/8	7-3/4	13-3/4	2-5/8	7-1/4	3-1/2	2-5/8	5/8	
2	3/4-1-1/4	3-3/8	7-3/4	13-3/4	2-5/8	8	3-1/2	2-5/8	5/8	
	1-1-1/2	3-3/8	7-3/4	13-3/4	2-5/8	8-1/4	3-1/2	2-5/8	5/8	
	1-1/2-2	3-3/8	7-3/4	13-3/4	2-5/8	8-3/4	3-1/2	2-5/8	5/8	
4	0-1	3-5/8	9-1/2	17-3/8	3-1/2	8-3/4	4-1/2	3	3/4	36
	3/4-1-1/2	3-5/8	9-1/2	17-3/8	3-1/2	9-1/4	4-1/2	3	3/4	
	1-1/4-2	3-5/8	9-1/2	17-3/8	3-1/2	9-3/4	4-1/2	3	3/4	
6	2-2-3/4	3-5/8	9-1/2	17-3/8	3-1/2	10-1/2	4-1/2	3	3/4	
	3/16-1-1/4	4-3/8	11-1/2	20-1/8	3-1/2	9-1/4	4-1/2	3-1/4	1-1/2	42
	1-2	4-3/8	11-1/2	20-1/8	3-1/2	10	4-1/2	3-1/4	1-1/2	
8	2-3	4-3/8	11-1/2	20-1/8	3-1/2	11	4-1/2	3-1/4	1-1/2	
	3-4	4-3/8	11-1/2	20-1/8	3-1/2	12	4-1/2	3-1/4	1-1/2	
	1/4-1-3/8	4-7/8	12-3/8	20-7/8	3-1/2	10-3/4	4-3/4	3-3/4	1-1/2	64
8	1-2-1/8	4-7/8	12-3/8	20-7/8	3-1/2	11-1/2	4-3/4	3-3/4	1-1/2	
	2-3-1/8	4-7/8	12-3/8	20-7/8	3-1/2	12-1/2	4-3/4	3-3/4	1-1/2	
	3-4-1/8	4-7/8	12-3/8	20-7/8	3-1/2	13-1/2	4-3/4	3-3/4	1-1/2	
8	3/8-1-1/2	5-3/8	12-3/4	22-5/8	3-3/4	12-3/8	5-1/4	4-1/4	2	83
	1-2-1/8	5-3/8	12-3/4	22-5/8	3-3/4	13	5-1/4	4-1/4	2	
	2-3-1/8	5-3/8	12-3/4	22-5/8	3-3/4	14-5/8	5-1/4	4-1/4	2	
	3-4-1/8	5-3/8	12-3/4	22-5/8	3-3/4	15-5/8	5-1/4	4-1/4	2	

L TABLE OF CONTENTS

Model JA Lifting Clamp

A vertical lifting clamp capable of turning a single plate or member from horizontal to vertical and back to horizontal through a 180 degree arc. Incorporates a push button auxiliary lock.

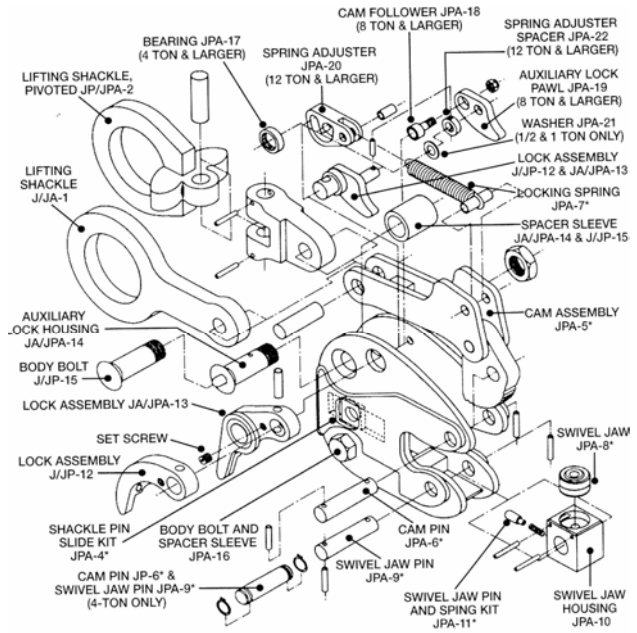
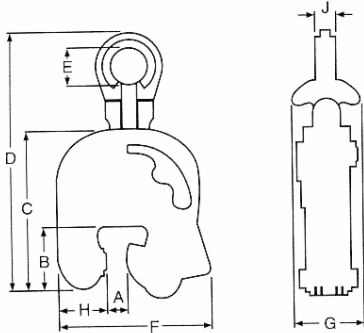

MODEL JA LIFTING CLAMP

Rated Capacity In Tons	Plate Thickness A	B	C	Max. D	E	F	G	H	J	Weight in Lbs.
1/2	0-5/8	2-3/4	6-1/2	12	2-3/8	5-5/8	3-1/4	2-1/4	1/2	10
	1/2-1	2-3/4	6-1/2	12	2-3/8	6	3-1/4	2-1/4	1/2	10
	3/4-1-1/4	2-3/4	6-1/2	12	2-3/8	6-1/4	3-1/4	2-1/4	1/2	10
	1-1/4-1-3/4	2-3/4	6-1/2	12	2-3/8	6-3/4	3-1/4	2-1/4	1/2	10
1	0-3/4	3-3/8	7-3/4	13-3/4	2-5/8	7	3-1/2	2-5/8	5/8	15
	1/2-1	3-3/8	7-3/4	13-3/4	2-5/8	7-1/4	3-1/2	2-5/8	5/8	15
	3/4-1-1/4	3-3/8	7-3/4	13-3/4	2-5/8	8	3-1/2	2-5/8	5/8	15
	1-1-1/2	3-3/8	7-3/4	13-3/4	2-5/8	8-1/4	3-1/2	2-5/8	5/8	15
2	1-1/2-2	3-3/8	7-3/4	13-3/4	2-5/8	8-3/4	3-1/2	2-5/8	5/8	15
	0-1	3-5/8	9-1/2	17-3/8	3-1/2	8-3/4	4-1/2	3	3/4	36
	3/4-1-1/2	3-5/8	9-1/2	17-3/8	3-1/2	9-1/4	4-1/2	3	3/4	36
	1-1/4-2	3-5/8	9-1/2	17-3/8	3-1/2	9-3/4	4-1/2	3	3/4	36
4	2-2-3/4	3-5/8	9-1/2	17-3/8	3-1/2	10-1/2	4-1/2	3	3/4	36
	3/16-1-1/4	4-3/8	11-1/2	20-1/8	3-1/2	9-1/4	4-1/2	3-1/4	1-1/2	42
	1-2	4-3/8	11-1/2	20-1/8	3-1/2	10	4-1/2	3-1/4	1-1/2	42
	2-3	4-3/8	11-1/2	20-1/8	3-1/2	11	4-1/2	3-1/4	1-1/2	42
6	3-4	4-3/8	11-1/2	20-1/8	3-1/2	12	4-1/2	3-1/4	1-1/2	42
	1/4-1-3/8	4-7/8	12-3/8	20-7/8	3-1/2	10-3/4	4-3/4	3-3/4	1-1/2	64
	1-2-1/8	4-7/8	12-3/8	20-7/8	3-1/2	11-1/2	4-3/4	3-3/4	1-1/2	64
	2-3-1/8	4-7/8	12-3/8	20-7/8	3-1/2	12-1/2	4-3/4	3-3/4	1-1/2	64
8	3-4-1/8	4-7/8	12-3/8	20-7/8	3-1/2	13-1/2	4-3/4	3-3/4	1-1/2	64
	3/8-1-1/2	5-3/8	12-3/4	22-5/8	3-3/4	12-3/8	5-1/4	4-1/4	2	83
	1-2-1/8	5-3/8	12-3/4	22-5/8	3-3/4	13	5-1/4	4-1/4	2	83
	2-3-1/8	5-3/8	12-3/4	22-5/8	3-3/4	14-5/8	5-1/4	4-1/4	2	83
	3-4-1/8	5-3/8	12-3/4	22-5/8	3-3/4	15-5/8	5-1/4	4-1/4	2	83

T LIFTING CLAMPS

Model JP Lifting Clamp

Model JP is a vertical lifting clamp capable of turning a single plate or member from horizontal to vertical and back to horizontal through the same 90 degree arc. Permits side loading of lifting shackle up to 90 degrees by derating of clamp's rated capacity. Refer to Fig.1 for derated capacities.

Model JP incorporates a pivoting shackle that permits side loading of the lifting shackle at 100 percent of rated capacity from vertical to 30 degrees. 75 percent of capacity between 30 and 45 degrees and 50 percent of rated capacity between 45 and 90 degrees.

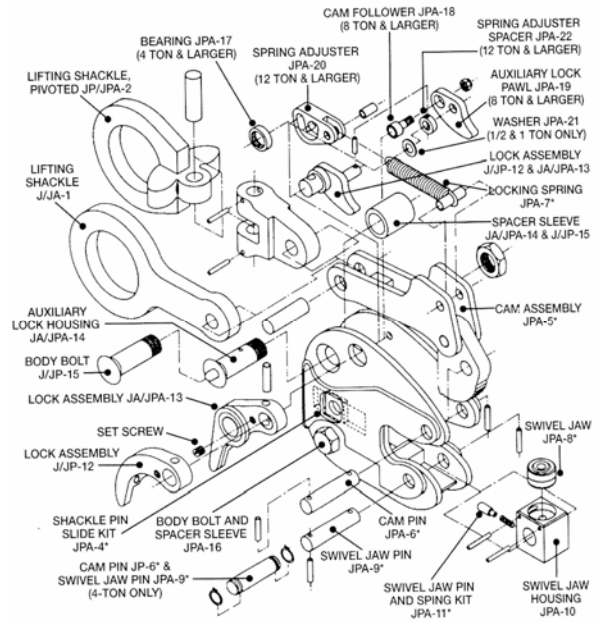
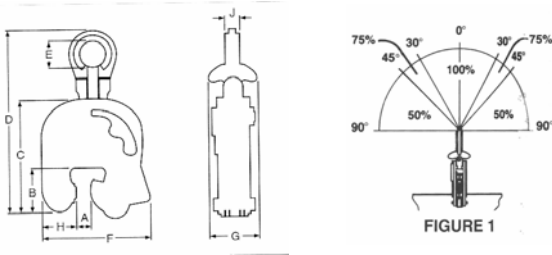

MODEL JP LIFTING CLAMP										
Rated Capacity In Tons	Plate Thickness A	B	C	Max. D	E	F	G	H	J	Weight in Lbs.
1/2	0-5/8	2-3/4	6-1/2	12	2-3/8	5-5/8	3-1/4	2-1/4	1/2	12
	1/2-1	2-3/4	6-1/2	12	2-3/8	6	3-1/4	2-1/4	1/2	12
	3/4-1-1/4	2-3/4	6-1/2	12	2-3/8	6-1/4	3-1/4	2-1/4	1/2	12
	1-1/4-1-3/4	2-3/4	6-1/2	12	2-3/8	6-3/4	3-1/4	2-1/4	1/2	12
1	0-3/4	3-3/8	7-3/4	13-3/4	2-5/8	7	3-1/2	2-5/8	5/8	20
	1/2-1	3-3/8	7-3/4	13-3/4	2-5/8	7-1/4	3-1/2	2-5/8	5/8	20
	3/4-1-1/4	3-3/8	7-3/4	13-3/4	2-5/8	8	3-1/2	2-5/8	5/8	20
	1-1-1/2	3-3/8	7-3/4	13-3/4	2-5/8	8-1/4	3-1/2	2-5/8	5/8	20
2	1-1/2-2	3-3/8	7-3/4	13-3/4	2-5/8	8-3/4	3-1/2	2-5/8	5/8	20
	0-1	3-5/8	9-1/2	17-3/8	3-1/2	8-3/4	4-1/2	3	3/4	40
	3/4-1-1/2	3-5/8	9-1/2	17-3/8	3-1/2	9-1/4	4-1/2	3	3/4	40
	1-1/4-2	3-5/8	9-1/2	17-3/8	3-1/2	9-3/4	4-1/2	3	3/4	40
4	2-2-3/4	3-5/8	9-1/2	17-3/8	3-1/2	10-1/2	4-1/2	3	3/4	40
	3/16-1-1/4	4-3/8	11-1/2	20-1/8	3-1/2	9-1/4	4-1/2	3-1/4	1-1/2	50
	1-2	4-3/8	11-1/2	20-1/8	3-1/2	10	4-1/2	3-1/4	1-1/2	50
	2-3	4-3/8	11-1/2	20-1/8	3-1/2	11	4-1/2	3-1/4	1-1/2	50
6	3-4	4-3/8	11-1/2	20-1/8	3-1/2	12	4-1/2	3-1/4	1-1/2	50
	1/4-1-3/8	4-7/8	12-3/8	20-7/8	3-1/2	10-3/4	4-3/4	3-3/4	1-1/2	72
	1-2-1/8	4-7/8	12-3/8	20-7/8	3-1/2	11-1/2	4-3/4	3-3/4	1-1/2	72
	2-3-1/8	4-7/8	12-3/8	20-7/8	3-1/2	12-1/2	4-3/4	3-3/4	1-1/2	72
8	3-4-1/8	4-7/8	12-3/8	20-7/8	3-1/2	13-1/2	4-3/4	3-3/4	1-1/2	72
	3/8-1-1/2	5-3/8	12-3/4	22-5/8	3-3/4	12-3/8	5-1/4	4-1/4	2	93
	1-2-1/8	5-3/8	12-3/4	22-5/8	3-3/4	13	5-1/4	4-1/4	2	93
	2-3-1/8	5-3/8	12-3/4	22-5/8	3-3/4	14-5/8	5-1/4	4-1/4	2	93
	3-4-1/8	5-3/8	12-3/4	22-5/8	3-3/4	15-5/8	5-1/4	4-1/4	2	93