

Vertical Band Saw

We recommend installing a hose retainer to keep the hose from interfering with the applicator or part.

Not supplied with the MerLube

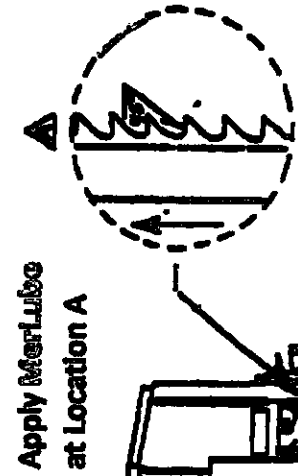

Apply MerLube at Location A

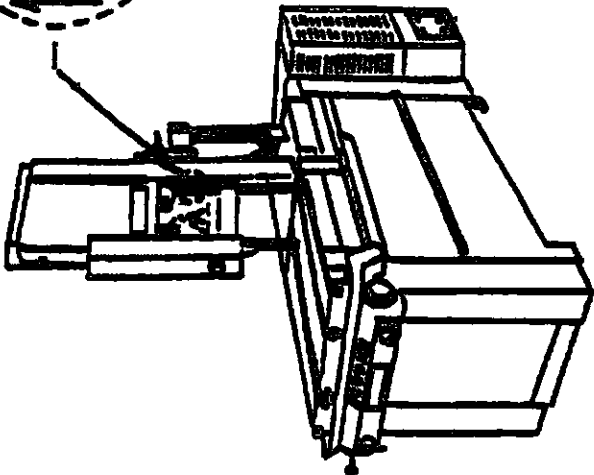

Applicator

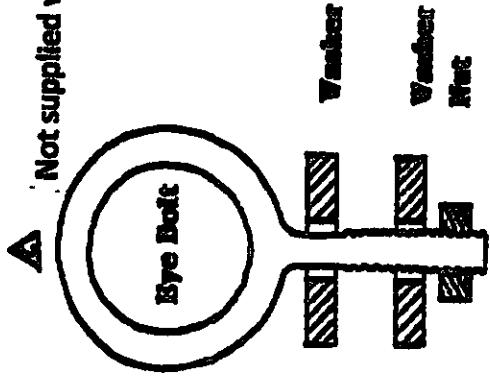

Eye Bolt

Washer

Washer Nut

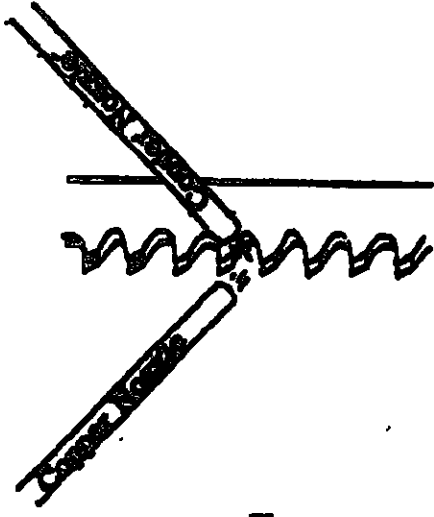

Relative position of the 2 copper nozzles to the band saw blade, cutting tooth and gullet.

MerLube should flow into the face of the tooth (gullet).

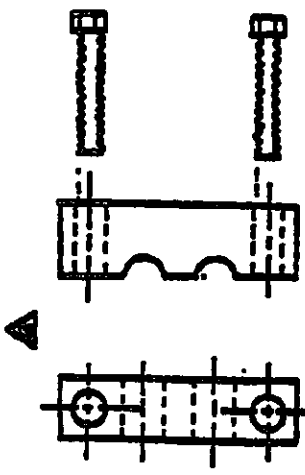

Top View

Side View

Copper Nozzle Mounting Block.

Merlicator option.

FYI:

1. It is recommended that 2 nozzles are used on all band saw applications.
2. Nozzles can be mounted wherever the blade is accessible. Position A shown above show that avoidance of workpiece interference.
3. The main objective is to coat the cutting edge of each tooth before it enters the cut. The use of 2 nozzles shown in the above configuration allows for some MerLube on the side of the blade.