

# OI-CMF Series Coriolis Mass Flow Meter

## Operating Manual

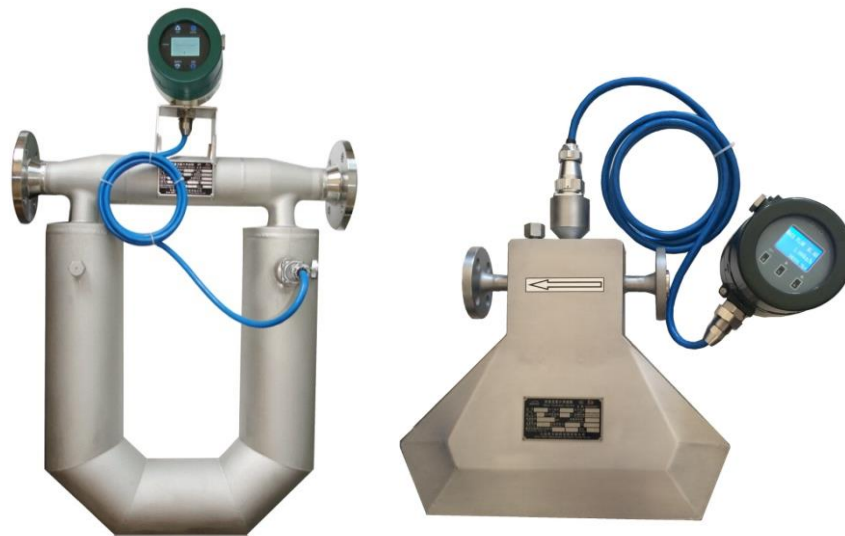

# Oasis Instrument Co., LTD.

## Content

1 OI-CMF series Mass Flow Meter Overview.....	1
1.1 Main Features.....	1
1.2 Application .....	1
1.3 Working Principle .....	2
2 Sensor Structure and Main Parameters.....	3
2.1 Sensor Structure .....	3
2.2 Technical Parameters .....	4
2.3 Sensor Installation.....	5
3 Selection and Installation .....	8
3.1 Selection.....	8
3.2 Installation .....	9
3.2.1 Basic Requirements on installation.....	9
3.2.2 Installation Direction .....	10
3.2.3 Sensor Fixed.....	11
4 FT-522 Transmitter operating manual .....	12
4.1 Overview.....	12
4.2 Main Parameters.....	12

---

4.3 Structure Description .....	13
4.3.1 Transmitter Panel.....	13
4.3.2 Wiring Terminals.....	15
5 Use .....	18
5.1 Installation .....	18
5.2 Wiring.....	18
5.2.1 Power line access.....	18
5.2.2 Pulse signal connection .....	19
5.2.3 Current signal connection.....	20
5.2.4 The wiring between transmitter and sensor.....	20
5.3 User working parameter setting and adjustment.....	23
5.3.1 Enter user working parameter setting status .....	23
5.3.2 User working parameter setting description .....	24
5.3.3 Output signal option setting.....	27
5.3.4 Alarm setting.....	27
5.3.5 Zero adjustment .....	27
5.3.6 Total flow reset.....	27
5.3.7 Auxiliary function setting .....	28
6. Calibration and Adjustment (Engineering parameter setting) .....	28
7. Attention for Anti-explosion .....	30
8. Model Selection .....	31

# 1 OI-CMF series Mass Flow Meter Overview

Coriolis mass flow meter (OI-CMF series) is a new type of flow meter which is designed according to Coriolis principle. This kind of new flow meter can measure the fluid directly in a sealed pipeline. It consists of two sections: Sensor and Signal Transmitter.

## 1.1 Main Features

- Unchallengeable OI-CMF series performance on liquid mass flow, volume flow, and density measurement
- Unique design delivers unparalleled measurement sensitivity and stability
- Guarantees consistent, reliable performance over the widest flow range
- Designed to minimize process, mounting, and environmental effect

## 1.2 Application

The OI-CMF series mass flow meter can be used in the following fields to meet the requirements of ingredient, mixing processes and commercial measurement.

- Chemical: containing chemical reaction system
- Petroleum: moisture content analysis
- Lipids: including vegetable oils, animal fats and other oils
- Pharmaceutical
- Painting
- Paper making
- Textile printing and dyeing
- Fuel: crude oil, heavy oil, coal slurry, lubricant, and other fuels.
- Food: gas dissolving beverage, health drink and other liquid.
- Transportation: pipeline liquid measurement.
- Low temperature fluid, like liquid oxygen and liquid nitrogen, the low temperature up to -200°C
- High temperature fluid, the maximum temperature up to 300°C
- High pressure fluid, like slurry flow measurement for oil drilling cementing

### 1.3 Working Principle

If a pipe is rotated around a point (P) while liquid is flowing through it (toward or away from the center of rotation), that fluid will generate an inertial force, with reference to Figure 1.1:

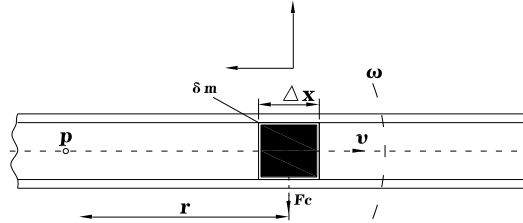

Figure 1-1

A particle ( $\delta m$ ) travels to the right at a constant velocity ( $v$ ) inside a tube. The tube is rotating around a fixed point (P) at angular velocity ( $\omega$ ), in this case, this particle will get two acceleration components:

1. Normal acceleration (centripetal acceleration), its value is equal to  $\omega^2 r$ , its direction is toward the point P
2. Tangential acceleration  $a_t$  (Coriolis acceleration), its value is equal to  $2\omega v$ , its direction is perpendicular to  $v$

The force generated by tangential acceleration is Coriolis force, its value is equal to  $F_c = 2\omega v \delta m$ . In figure 1.1 fluid  $\delta m = \rho A \times \Delta X$ , So Coriolis force can be expressed as:

$$\Delta F_c = 2\omega v \times \delta m = 2\omega v \times \rho A \times \Delta X = 2\omega \times \delta q_m \times \Delta X$$

Wherein A is the duct cross-sectional area.

$$\delta q_m = \delta m / dt = \rho v A$$

For special rotational pipe, its frequency is constant,  $\Delta F_c$  only depends on  $\delta q_m$ . Therefore, directly or indirectly measuring the Coriolis force can be measured mass flow. This is how Coriolis mass flow meter works.

The actual flow sensor can't achieve rotational movement, replace by pipeline vibration. The principle is shown in Figure 1.2, Figure 1.3, Figure 1.4. Both ends of a bend pipe are fixed, and the vibration force is applied to the pipe in an middle of the two fixed points (according to the resonance frequency of pipeline), taking the fixed point as axis, making pipeline vibrate at its natural frequency ( $\omega$ ). When no fluid flows through the pipeline, the pipeline is only affected by vibration force, the vibration direction of two half-section of pipeline is the same, no phase difference. When fluid flows, by the influence of fluid medium Coriolis force  $F_c$  inside the pipeline (In the two half-section of pipeline, Coriolis  $F_1$  and  $F_2$  are equal in magnitude and opposite in direction Figure 1.2), two half-section of pipeline occur twist in the opposite direction to generate phase difference which is proportional to mass flow. The design of sensor is converting the measurement of Coriolis force to the measurement of phase difference for both sides of the vibrating tube. This is the working principle of Coriolis mass flow meter.

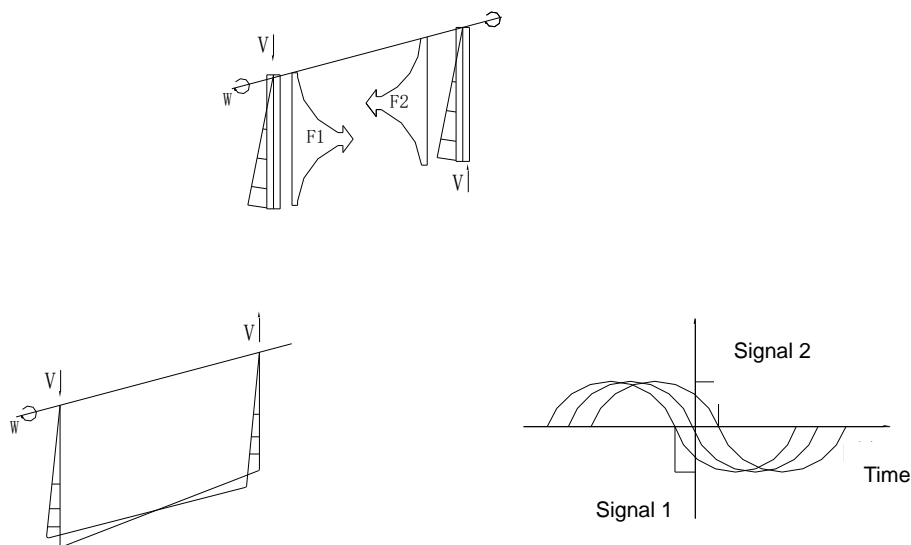
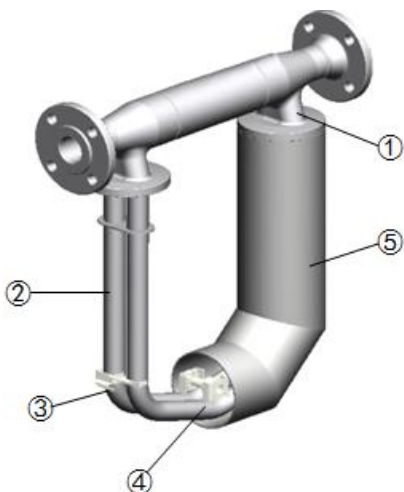

Figure 1-4

## 2 Sensor Structure and Main Parameters

### 2.1 Sensor Structure



LCMF series mass flow meter sensor consists of measurement tube, driving device, position detector, support structure, the temperature sensor, housing, etc.

- ① Supporting structure: the measuring tube fixed on the supporting structure as the vibrating axis.
- ② The measuring tube (Vibrating tube): consist of two parallel tubes.
- ③ Position detector: used for the measurement of measuring tube distortion.
- ④ Drive device: generate electromagnetic force to drive measuring tube to make it vibrate close to resonance frequency.
- ⑤ Housing: Protect the measuring tube, driving unit and detector.

## 2.2 Technical Parameters

- Dimension and Measuring Range

Specification	DN (mm)	Flow range(kg/h)	Zero Stability, kg/h			Rated Pressure (MPa)	NW (kg)	GW (kg)
			0.2%	0.15%	0.1%			
OI-CMF-003	3	0~96~120	0.018	0.012	0.012	40	8	19
OI-CMF-006	6	0~540~660	0.099	0.066	0.066	20	12	22
OI-CMF-008	8	0~960~1200	0.18	0.12	0.12	20	12	23
OI-CMF-010	10	0~1500~1800	0.27	0.18	0.18	20	11	24
OI-CMF-015	15	0~3000~4200	0.63	0.42	0.42	20	12	25
OI-CMF-020	20	0~6000~7800	1.17	0.78	0.78	16	20	34
OI-CMF-025	25	0~10200~13500	2.025	1.35	1.35	16	21	35
OI-CMF-032	32	0~18 000~24 000	3.6	2.4	2.4	16	27	45
OI-CMF-040	40	0~30 000~36 000	5.4	3.6	3.6	12	35	55
OI-CMF-050	50	0~48 000~60 000	9	6	6	12	40	60
OI-CMF-080	80	0~120 000~160 000	24	16	16	8	90	150
OI-CMF-100	100	0~222 000~270 000	40.5	27	27	8	170	245
OI-CMF-150	150	0~480 000~600 000	90	60	60	6	255	350

- Accuracy(Liquid) :( With FT-522 Transmitter):

Measurement accuracy:  $\pm 0.1\% \pm (\text{zero stability/measurement value}) \%$

Measurement accuracy:  $\pm 0.15\% \pm (\text{zero stability/measurement value}) \%$

Measurement accuracy:  $\pm 0.2\% \pm (\text{zero stability/measurement value}) \%$

Repeatability: 1/2 measurement accuracy %

- Density(Liquid) measuring range and accuracy (With FT-522 series transmitter)

Range: 0.3~3.000g/cm<sup>3</sup>      Accuracy:  $\pm 0.002\text{g/cm}^3$

- Temperature measuring range and accuracy (With FT-522 transmitter):

Temperature measuring range: -200~350°C      Accuracy:  $\pm 1^\circ\text{C}$

- Ambient temperature:  $-20^\circ\text{C} \sim 60^\circ\text{C}$

- Material : The measuring tube SS316L    Housing: SS304

- Working pressure: 0~4.0MPa

- Explosion-proof level : Exd (ia) IIC T6Gb

## 2.3 Sensor Installation

“U” -type

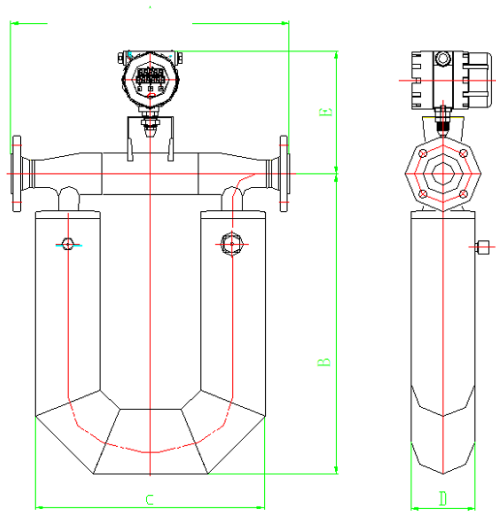

Figure2-2 Integrated type

Size	A	B	C	D	E	NW(only sensor)
	mm	mm	mm	mm	mm	kg
20	540	478	468	108	245	17
25	540	492	468	108	245	17.5
32	544	517	468	108	245	24
40	600	635	500	140	267	32
50	606	653	500	140	267	36
80	866	857	779	219	316	87.5
100	950	977	833	273	340	165



Triangle split type

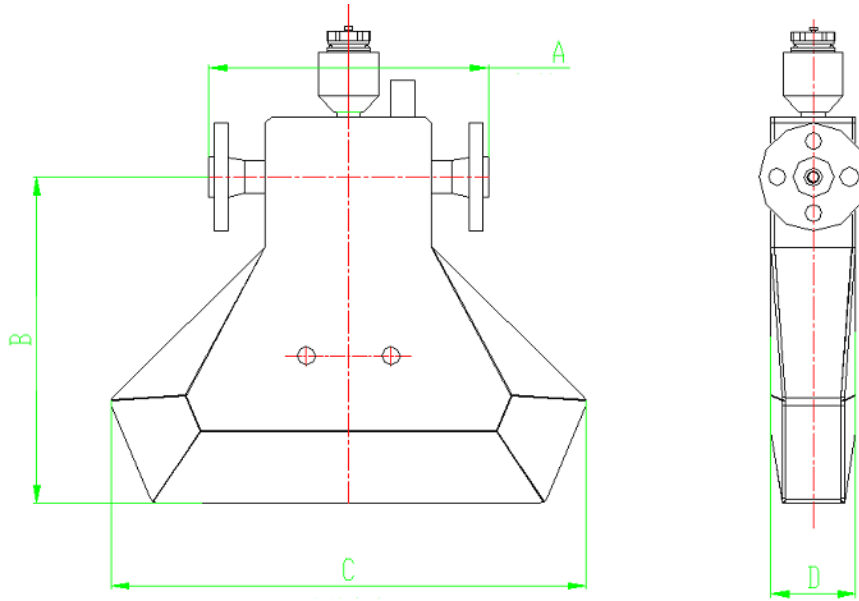

Figure 2-3 LCMF-003 / 006 / 008

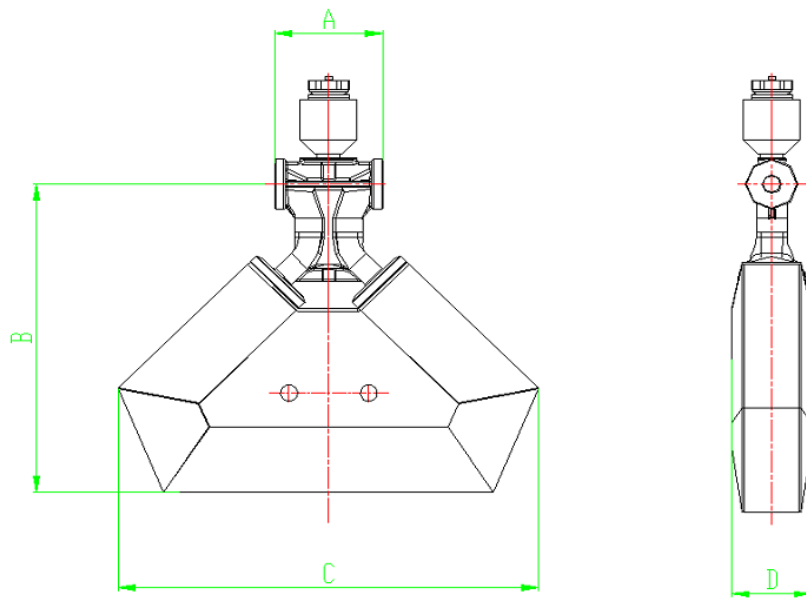

Figure 2-4 LCMF-010 / 015

Triangle integral type

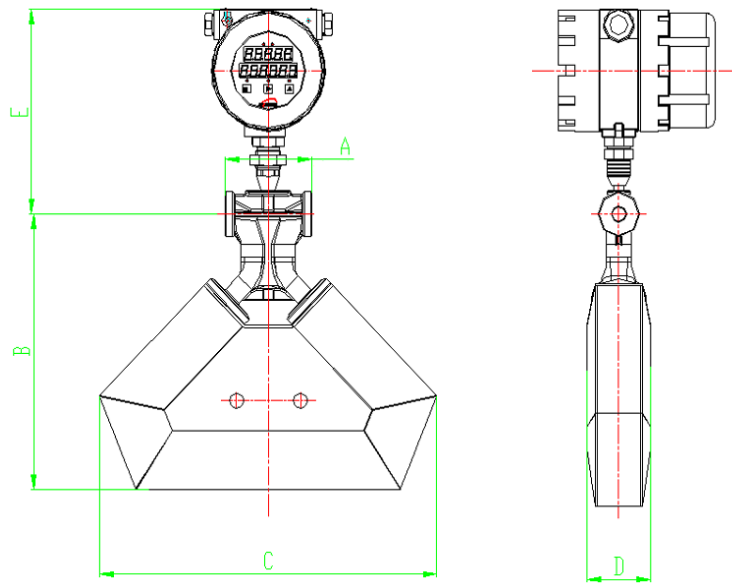

Figure 2-5 LCMF-010 / 015

size	A	B	C	D	E	NW
	mm	mm	mm	mm	mm	kg
3	196	176	250	54	270	4.8
6	250	263	360	70.5	289	8.1
8	250	275	395	70.5	289	8.2
10	95	283	370	70.5	264	6.5
15	95	302	405	70.5	264	6.5

Note: A size will be changed with the different process connection.

## 3 Selection and Installation

### 3.1 Selection

The following conditions should be considered for flow meter selection.

Medium characteristics	<ul style="list-style-type: none"> <li>▪ Measurability Coriolis mass flow meter is widely used for lots of fluid, but some conditions like slug flow, pulsating flow etc, where you want to install Coriolis mass flow meter, some appropriate support measures must be taken.</li> <li>▪ Corrosivity Coriolis mass flow meter measuring tube material is SS316L, housing material SS304. If the standard material is not suitable for the medium, anticorrosion wetted material should be selected.</li> <li>▪ Operating temperature and pressure Standard configuration: -50...+200°C, 4.0MPa, please contact with manufacturer for special parameters.</li> <li>▪ Ambient condition Standard ambient temperature is -20...+60°C. The flow meter will fail to display if the ambient temperature exceeds the standard range. Please contact with manufacturer for special parameters.</li> <li>▪ Protection and Explosion Transmitter ex-proof: flame type, Sensor ex-proof: intrinsic type Transmitter and Sensor protection: IP67</li> </ul>
Preferred measuring range	1/3~2/3 of standard flow range
Allowable pressure loss	<p>Pressure loss should be considered especially for reduced pipe.</p> <p>Pressure loss reference table is shown as below</p>

Pressure Loss Reference Table

Diameter	Max standard flow	Pressure loss	Max extended flow	Pressure loss
mm	Kg/h	Pa	Kg/h	Pa
3	96	100000	120	150000
6	540	100000	660	150000
8	960	100000	1200	150000
10	1500	100000	1800	150000
15	3000	100000	4200	150000
20	6000	100000	7800	150000
25	10200	100000	13500	150000
32	18000	80000	24000	150000
40	30000	75000	36000	100000
50	48000	65000	60000	100000
80	120000	60000	160000	100000
100	222000	65000	270000	100000
150	480000	60000	600000	90000

## 3.2 Installation

### 3.2.1 Basic Requirements on installation

- Flow direction should be in accordance with OI-CMF series sensor flow arrow.
- Properly supporting is required for preventing tubes vibrating.
- If a strong pipeline vibration is inevitable, it is recommended to use a flexible tube to isolate the sensor from the pipe.
- Flanges should be kept parallel and their center points should be located on the same axis to avoid subsidiary force generation.
- Installation vertically, make the flow from the bottom up when measuring, meanwhile, the meter should not be installed on the top to prevent air getting trapped inside the tubes.

### 3.2.2 Installation Direction

In order to ensure the reliability of the measurement, the ways of installation should consider the following factors;

The meter should be installed downward when measuring liquid flow (Figure3-1), so that air cannot get trapped inside the tubes.

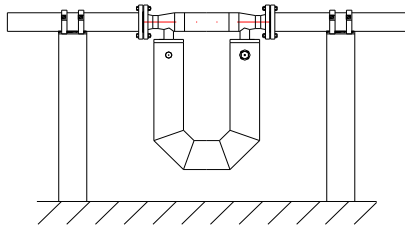

Figure 3-1

The meter should be installed upward when measuring gas flow (Figure3-2), so that liquid cannot get trapped inside the tubes.

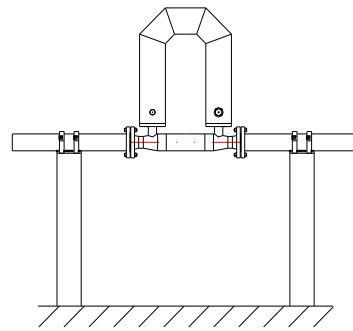

Figure 3-2

The meter should be installed sideward when the medium is turbid liquid (Figure3-3) to avoid particulate matter accumulated in the measuring tube. The flow direction of medium goes from the bottom up through the sensor.

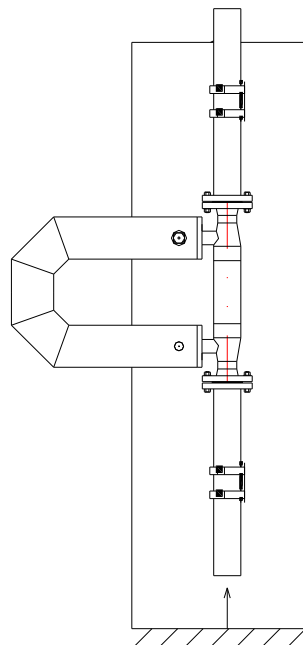

Figure 3-3

### 3.2.3 Sensor Fixed

Coriolis mass flowmeter is a vibrating instrument, when they work, the two vibrating tube is always in a state of vibration. Therefore, external vibration or pipeline vibration may have effect on their normal operation.

For small diameter coriolis mass flow meter, it is not easy to avoid vibration because of the small measuring tube, in this case, we provide installation bracket which is used for fixed. Please make sure that the installation bracket is installed on a stable interface. The installation diagram for small diameter is shown as Figure 3.4

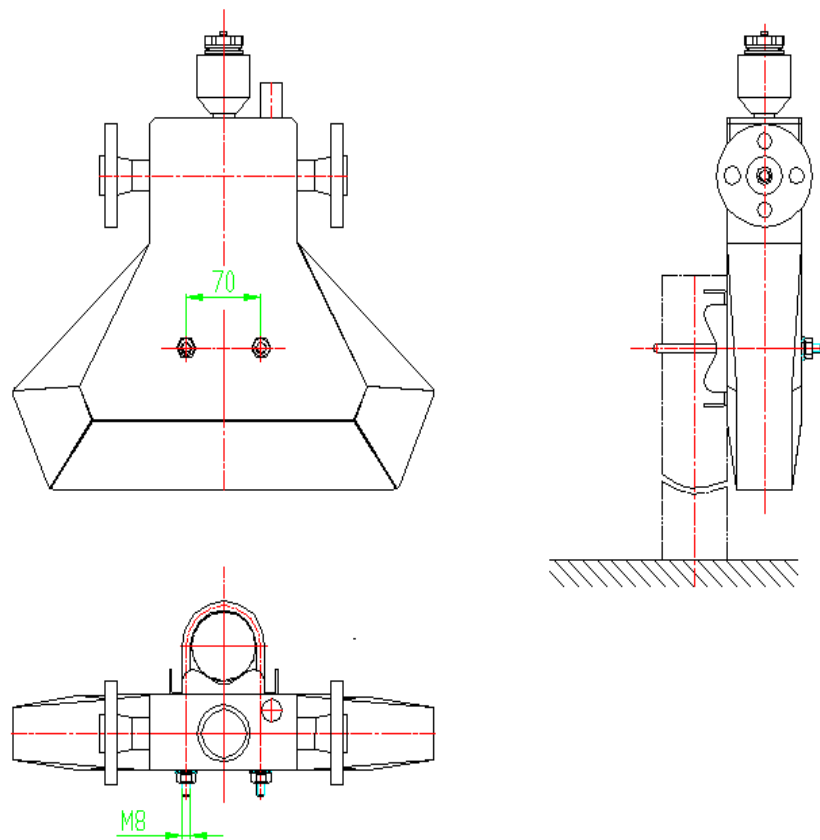

Figure 3-4 Sensor bracket installation drawing

## 4 FT-522 Transmitter operating manual

### 4.1 Overview

FT522 flow signal transmitter is used with OI-CMF series coriolis mass flow meter sensor, which has sensor vibrating tube driver, phase signal detection, flow rate operation display, flow integrating, signal remote transmitting and other functions.

### 4.2 Main Parameters

<b>Display</b>	128x64 LCD display, Window size: 54x40mm (WxH) $\Phi$ 80mm
<b>Display Accuracy</b>	0.02%
<b>Unit</b>	<p>Mass flow rate: g/h、kg/h、t/h、g/m、kg/m、t/m</p> <p>Total flow: g, kg, t</p> <p>Volume flow rate: cm<sup>3</sup>/h、dm<sup>3</sup>/h、m<sup>3</sup>/h、cm<sup>3</sup>/m、dm<sup>3</sup>/m、m<sup>3</sup>/m</p> <p>Total volume: cm<sup>3</sup>/m、dm<sup>3</sup>/m</p> <p>Density: kg/m<sup>3</sup>、g/cm<sup>3</sup></p> <p>Temperature: °C、K、°F</p>
<b>Ambient Temperature</b>	-20...+60°C
<b>Output Signal</b>	<p>0~10000Hz pulse frequency signal flow signal (open collector signal)</p> <p>Equivalent pulse signal flow signal</p> <p>4~20mA Current signal choose one signal from flow rate, density, temperature</p> <p>Current output load capacity is not less than 750<math>\Omega</math> (24VDC power supply)</p> <p>Accuracy: Pulse signal 0.05%</p> <p>Current signal 0.2%</p> <p>Communication signal: RS485, MODBUS protocol</p> <p>Hart</p>
<b>Power Supply</b>	<p>18~36VDC power<math>\geq</math>7W</p> <p>85~265VAC power: 10W</p>

<b>Protection</b>	Protection: IP67 Ex-proof: Ex d [ia] II CT6Gb
<b>Dimension</b>	Φ125×180mm
<b>GW</b>	2.7kg

### 4.3 Structure Description



Figure1.transmitter outline drawing

#### 4.3.1 Transmitter Panel

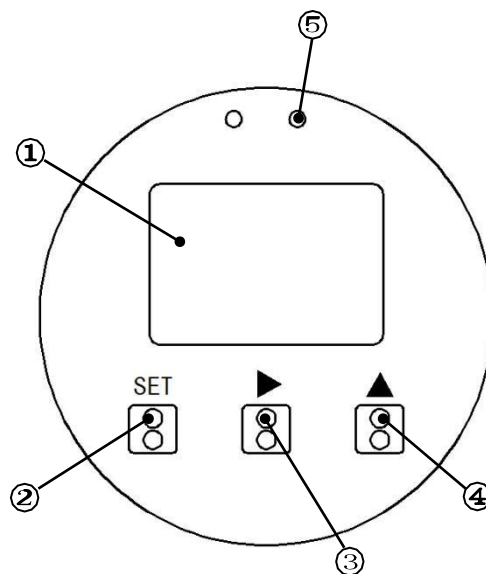

Figure2. Transmitter Panel



### 1) Measurement window

- Measurement window is 128x64 LCD displayer, three lines of characters display separately: measurement parameter, working parameter and setting parameters.
- Mass flow rate and total flow, volume flow rate and total volume, density, temperature can be displayed by page number.
- Under setting condition, the setting value of each parameter can be showed, modified and reset.

 :Parameter setting can be **ONLY** performed by authorized engineer, as parameter change can affect the accuracy of the flowmeter.

The display format of flow meter is listed below under normal operation:

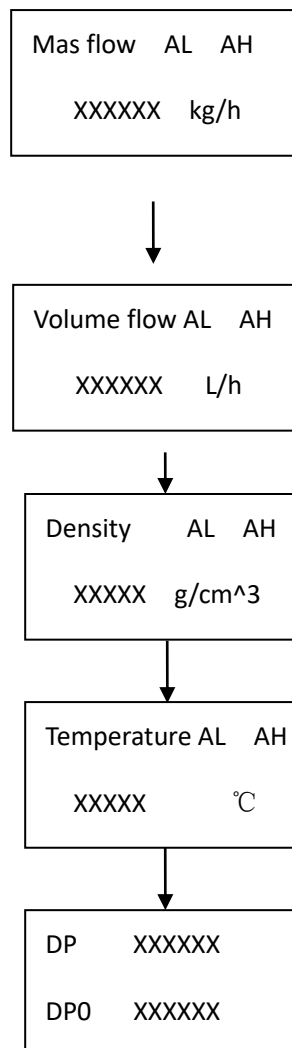

AL and AH represent alarm, when measurement value exceeds alarm setting value, the corresponding symbol will flash;  
FO,TP,DP,DPO are working parameters of flowmeter; The bottom line at the last page represents working clock.

Use  $\llbracket > \rrbracket$  and  $\llbracket \wedge \rrbracket$  to page up and page down.

2,3,4 are operation keys, which is made up of photoelectric switch.

## 2) $\llbracket \text{SET} \rrbracket$ Setting Key

Under measurement condition, press and hold  $\llbracket \text{SET} \rrbracket$  key to enter parameter setting status. The parameter setting of flowmeter include user parameter setting and engineering parameter setting. To ensure the operation security, a password is required to enter parameter setting status.

## 3) $\llbracket > \rrbracket$ Shift Key

Under measurement status, pressing shift key can page down;

Under setting status, pressing shift key can select setting content.

## 4) $\llbracket \wedge \rrbracket$ Add Key

Under measurement status, pressing add key can page up;

Under setting status, pressing add key can change setting value.

Press  $\llbracket \wedge \rrbracket$  key .....→

0 1 2 3 4 5 6 7 8 9 .

## 5) Status Light

The status light will flash only for zero operation and fault.

### 4.3.2 Wiring Terminals

The transmitter contains two kinds of wiring terminal boards: the normal wiring terminal board (24VDC power supply) and auxiliary wiring terminal board (220VAC power supply).

1) The normal wiring terminal board, showed in Figure 3

Power supply wiring terminals from top to bottom	Grounding terminal, Null terminal, 24V-terminal, 24+ terminal. External 24VDC power supply line connects to 24+, 24- terminals.
Signal wiring terminals from top to bottom	Alarm output signal terminal2, Alarm output signal terminal, RS485 communication interface A terminal, RS485 communication interface B terminal, Current signal output terminal, Pulse signal output terminal, COM terminal, 24V+ terminal.
Alarm output signal	It's a switch signal, which can be set for output flow or density and temperature high and low alarm control signal.
A and B	RS485 communication signal wiring terminals.
Current output signal	Remote current output signal of flow or density measurement value
Pulse output signal	Output pulse frequency signal corresponding to the rate of flow  Output pulse equivalent signal corresponding to the flow equivalent

The common terminal for alarm, current output and pulse output is 24V-, that is COM terminal.

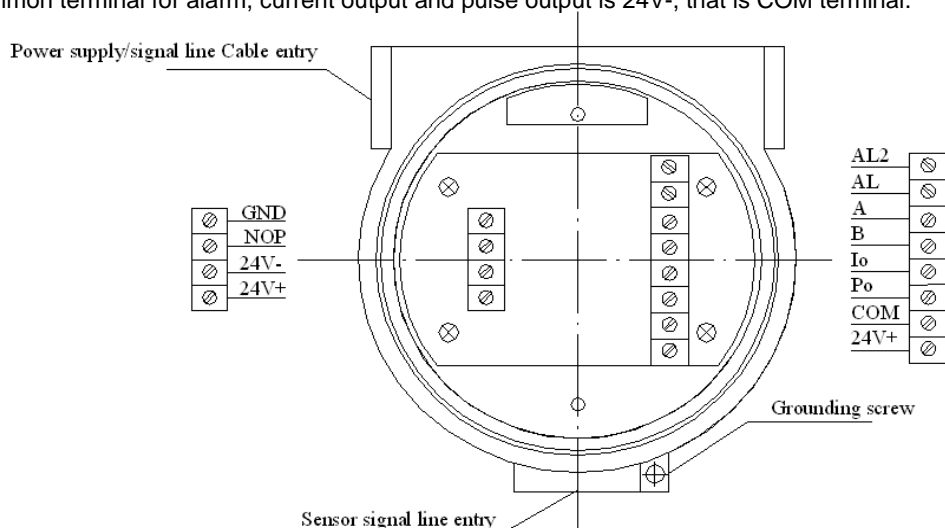

Figure 3. 24VDC Power supply wiring board

2) The auxiliary wiring terminal board, showed in Figure4

Power supply wiring terminals from top to bottom	Grounding terminal, Null terminal, 220VAC terminal 1#, 220VAC terminal 2#
Signal wiring terminals from top to bottom	Alarm output signal terminal2, Alarm output signal terminal, RS485 communication interface A terminal, RS485 communication interface B terminal, Current signal output terminal, Pulse signal output terminal, COM ( 24V- terminal), 24V+ terminal. The common terminal of output signal is 24V-

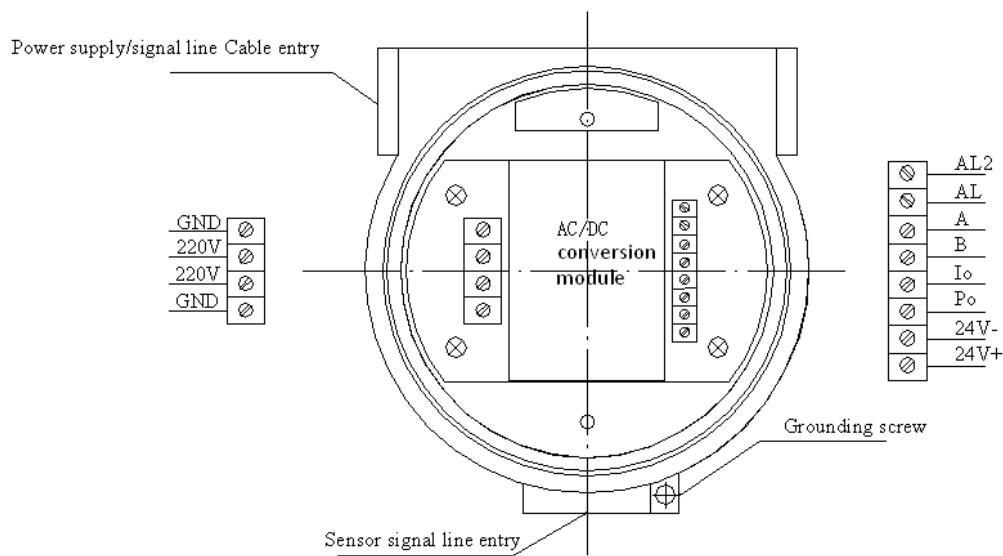
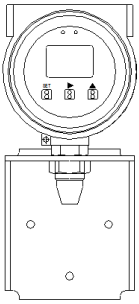
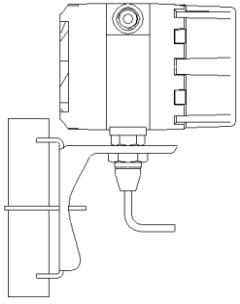

Figure 4. 220VAC Power supply wiring board

## 5 Use

### 5.1 Installation

Installation Type	Description
<p>Figure5.</p> 	<p><b>FT-522 Integrated type</b></p> <p>The signal lines between sensor and transmitter have been connected well before delivery, the users only need to connect external wiring.</p>
<p>Figure6.</p> 	<p><b>FT522 Remote type</b></p> <p>Mounting bracket will be equipped for remote type.</p> <p>Cable length for standard configuration is 2m</p> <p>Side-wiring for transmitter has been connected well before delivery.</p> <p>Use air plug to connect transmitter and sensor (air plug protection is IP67)</p>

### 5.2 Wiring

#### 5.2.1 Power line access

- The normal power supply for flow meter is 24VDC. Power consumption is required to be not less than 7W. The power terminal and signal terminal in junction box is mounted separately and marked clearly.
- The power input in the flow meter has protective device for avoiding a faulty polarity connection. But for safe wiring, please note the polarity of the power line.
- Please don't connect the power line to the signal wiring terminal.

- When 24V power is provided by secondary instrument or computer system, signal grounding line don't need another connection, which can realize three-wire work.

### 5.2.2 Pulse signal connection

The output type for transmitter pulse signal is open collector passive signal output. For normal wiring, relevant power supply and signal detection resistance should be provided at the side of signal reception. When the power supply is 24VDC, signal detection resistance value selects 5 K $\Omega$ /0.25W (at this time, signal transmission current is 4~5mA). In order to improve the anti-interference ability of signal transmission, passive signal output type should be used. Wiring diagram as blow:

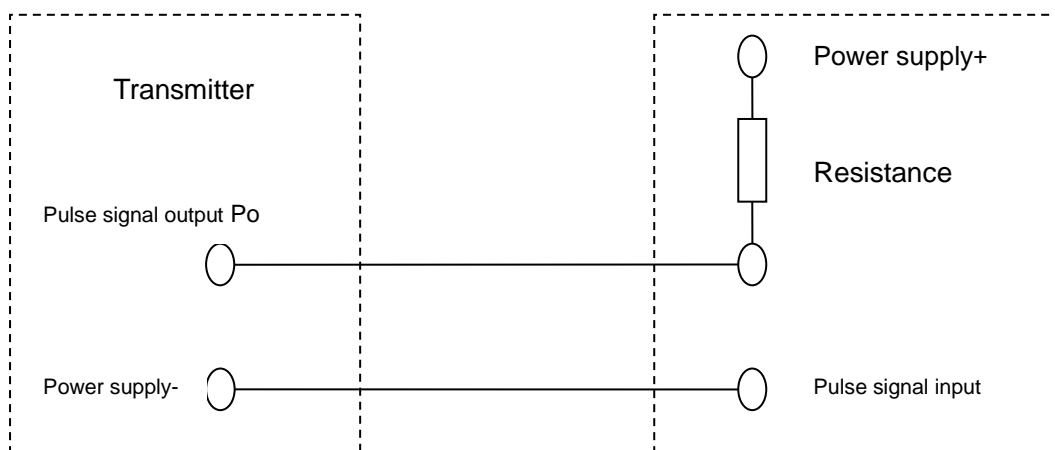

Figure 7. Pulse signal output wiring diagram (passive output)

If active pulse output signal provided by the transmitter is required, connect signal transmission resistance to both flow meter power supply + and pulse signal output terminal, shown as figure 8

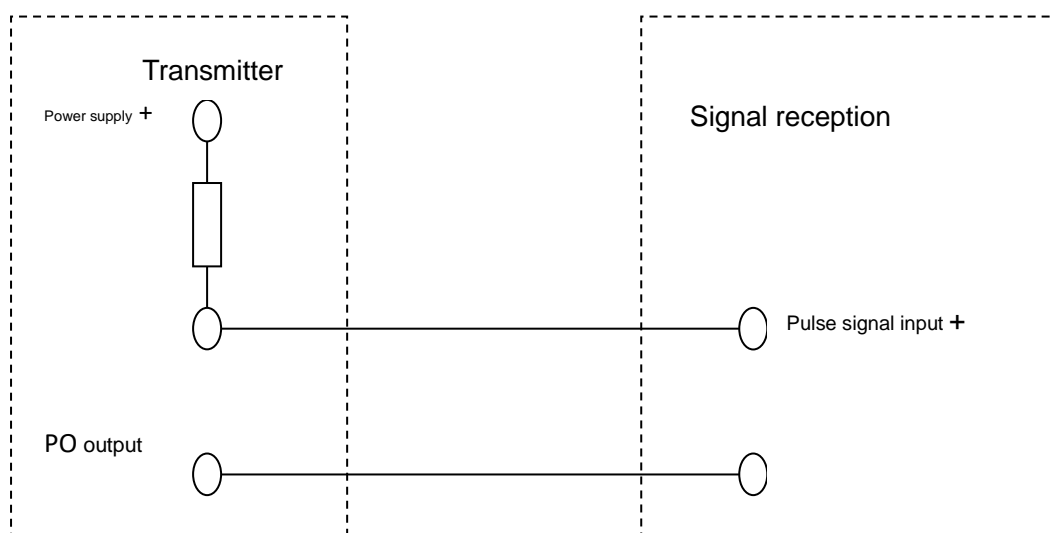

Figure 8. Pulse signal output wiring diagram (active output)

### 5.2.3 Current signal connection

Current output signal is active signal, shown as Figure 9

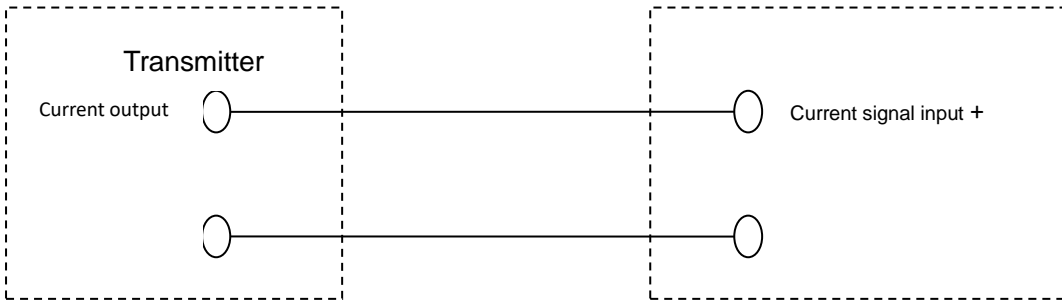

Figure 9. Current signal output wiring diagram

When output 1-5VDC power signal is required, access 250Ω standard resistance to the signal reception to realize the transition of current and power , which is shown as figure 10:

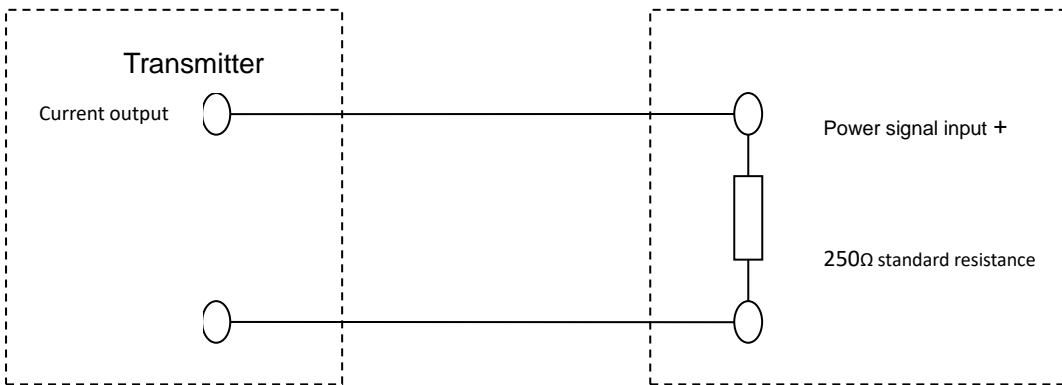

Figure 10. Power supply signal transition diagram

### 5.2.4 The wiring between transmitter and sensor

The junction box equipped with sensor and the terminals in the junction box are shown as Figure 11:

For integrated installation, the wiring between transmitter and sensor is in the mounting socket of transmitter and connected well before delivery. The signal connection between transmitter and sensor for remote type is mentioned as below:

The wiring socket is equipped with the sensor. connect FT522 type transmitter and sensor through the wiring socket. The protection level for wiring socket is IP67. The wiring socket and the terminals of lead wire are shown as figure 11:

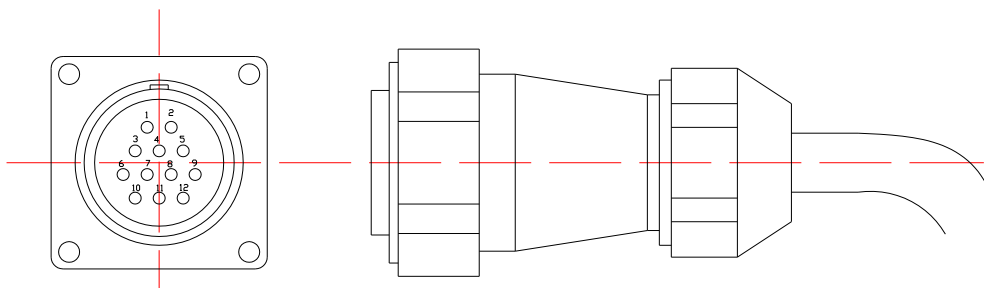

Figure 11

Terminal number and corresponding wiring is shown as blow:

Terminal 1、2 D group	the sensor driving signal terminal D1、 D2
Terminal 3、 4 L group	Measurement signal terminal L1、 L2 at the left of sensor
Terminal 5、 6 R group	Measurement signal terminal R1、 R2 at the right of sensor
Terminal 7、 8、 9、 10 T group	the sensor temperature measurement signal terminal T1、 T2、 T3、 T4

Special wire should be used for the connection of sensor signal wire. Use special signal cable, wiring as the color of core wire, crimp or solder lug. Incoming line should be sealed to protect the junction box from air leakage and water leakage.

D group	red connects D1, blue connects D2, cut off shielding wire.
L group	white connects L1, yellow connects L2, cut off shielding wire.
R group	gray connects R1, purple connects R2, cut off shielding wire.
T group	green and orange connect T1.2, black and shielding connect T3.4

The shielding wire of T group should wear insulation tube. All wiring including shielding wire can not touch the housing.



**⚠** *The transmitter internal wiring has been connected well before delivery, the users only need to connect air plug to air socket and lock the plug.*

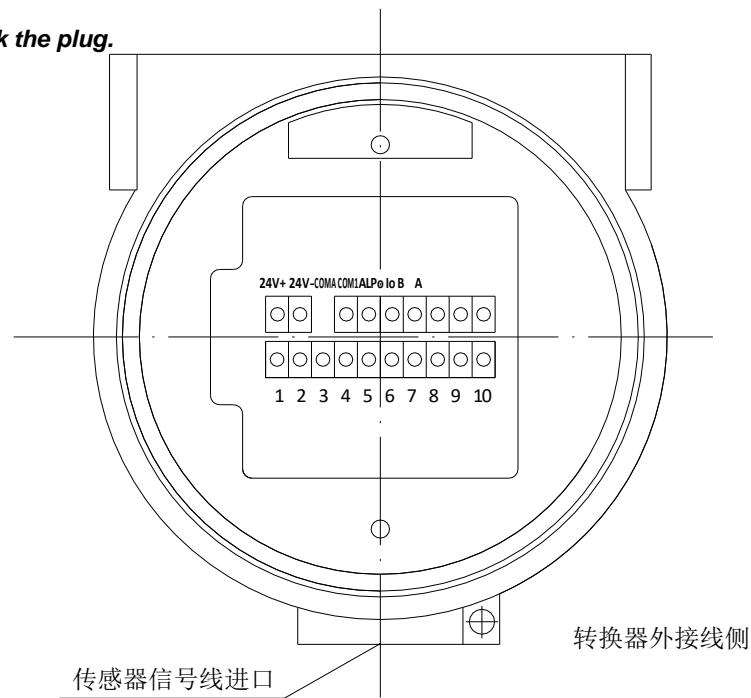

Sensor signal line entry

Transmitter external wiring

**Figure12. Internal Wiring Terminal Diagram**

- |           |                       |  |
|-----------|-----------------------|--|
| 1 (red)   | 2 (blue, shielding)   | sensor vibration tube driving signal terminals |
| 3 (white) | 4 (yellow, shielding) | the right side of sensor signal terminals      |
| 5 (gray)  | 6 (purple)            | the left side of sensor signal terminals       |
| 7 (green) | 8 (orange)            | temperature measuring signal terminals         |
| 9 (black) | 10 (shielding)        |  |

## 5.3 User working parameter setting and adjustment.

Generally, factory will finish the setting and adjustment of working parameter as required, users do not need to readjust in the field.

Only in the following cases, users can adjust parameter:

- Change measuring unit
- Output signal option adjustment and range adjustment
- The setting and adjustment for measuring parameter alarm value
- Zero adjustment and total flow reset.
- The adjustment for communication parameter, etc..

### 5.3.1 Enter user working parameter setting status.

- 1) Under measurement status, press `[[SET]]` key until screen displays parameter setting interface.
- 2) Press `[[>]]` key to select user setting item, then press `[[SET]]` to confirm and enter password setting status.
- 3) Use `[[>]]` to select operation position, use `[[^]]` to select operands, at last use `[[SET]]` to confirm. When password is right, the system will enter user setting status, then user can modify parameter as prompt .
- 4) After finishing all parameter setting, the flow meter can exit automatically or press exit options.

### 5.3.2 User working parameter setting description.

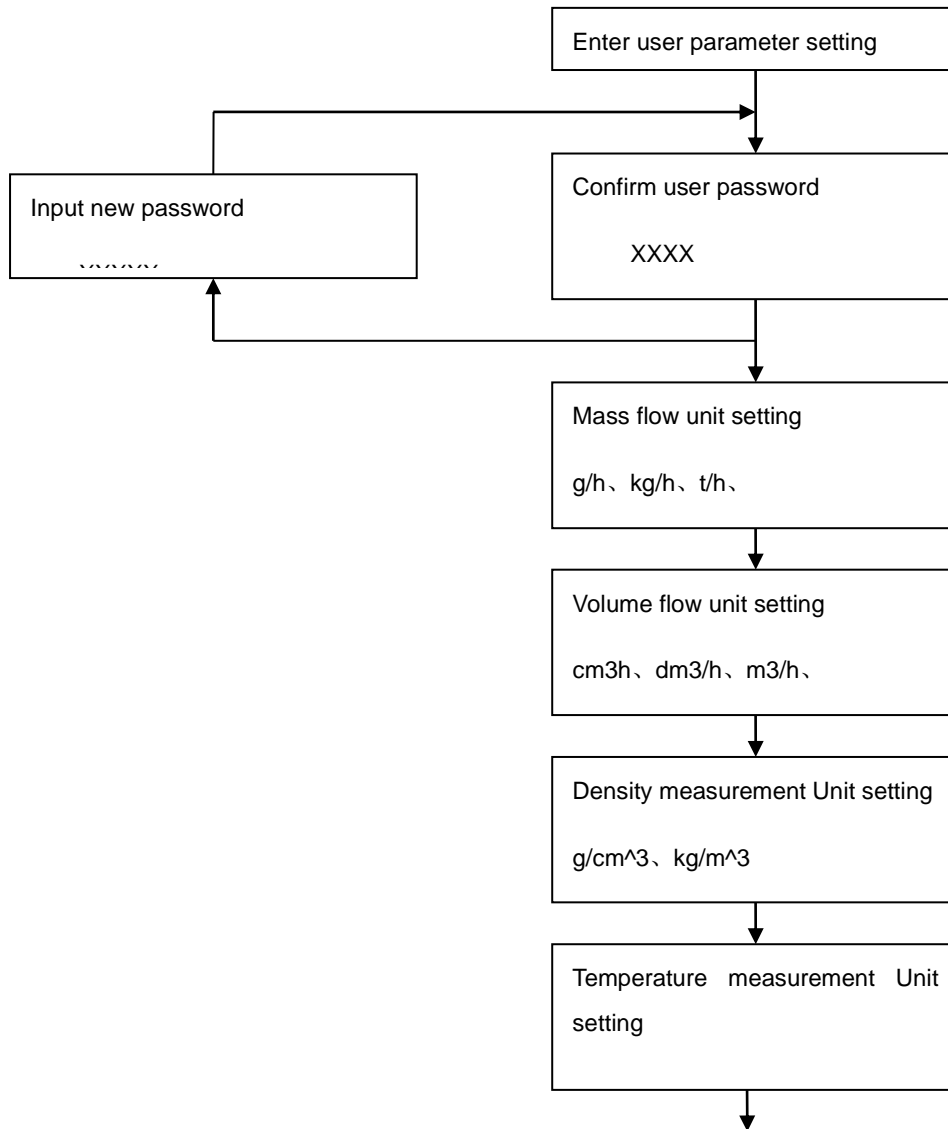

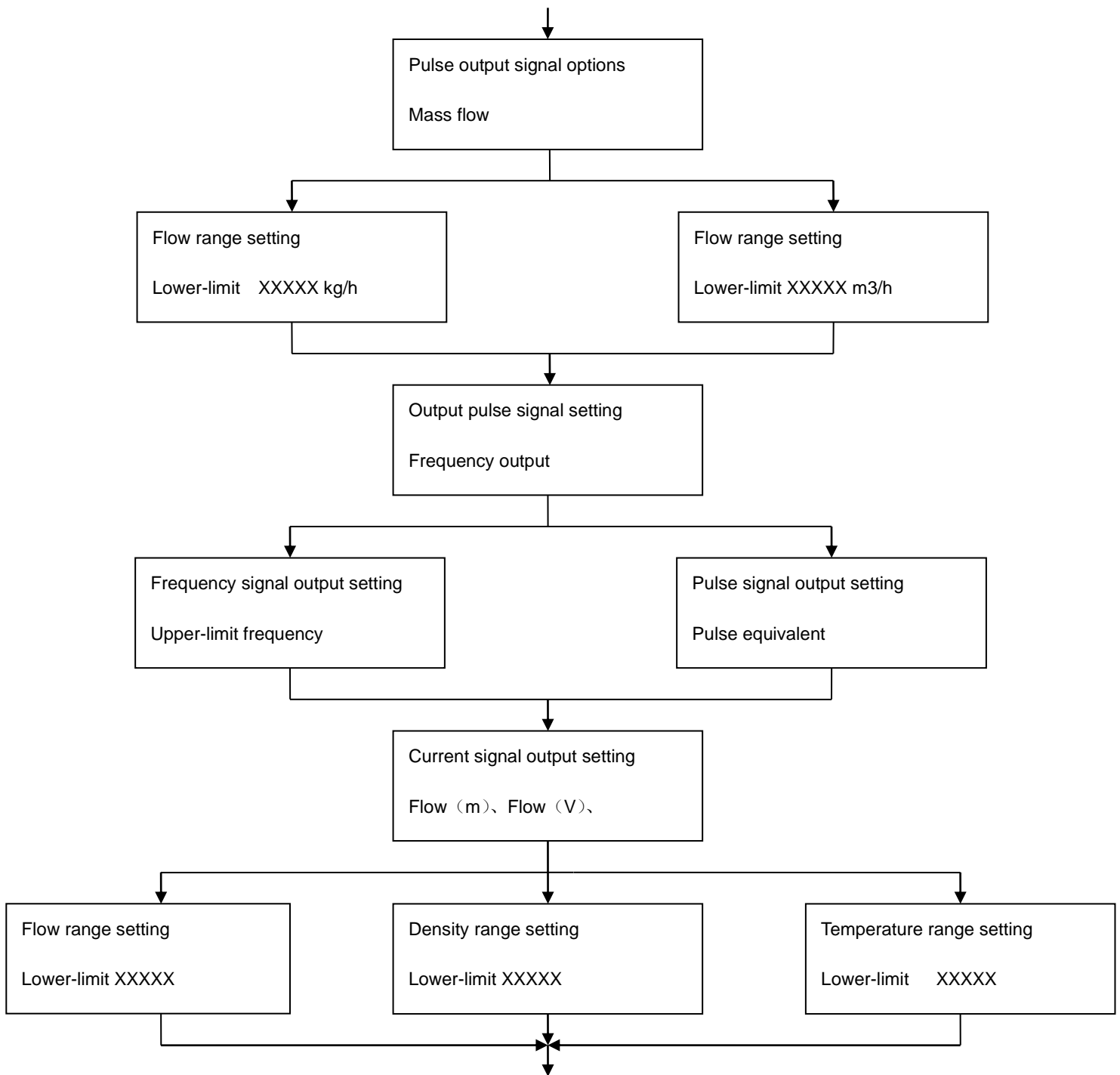

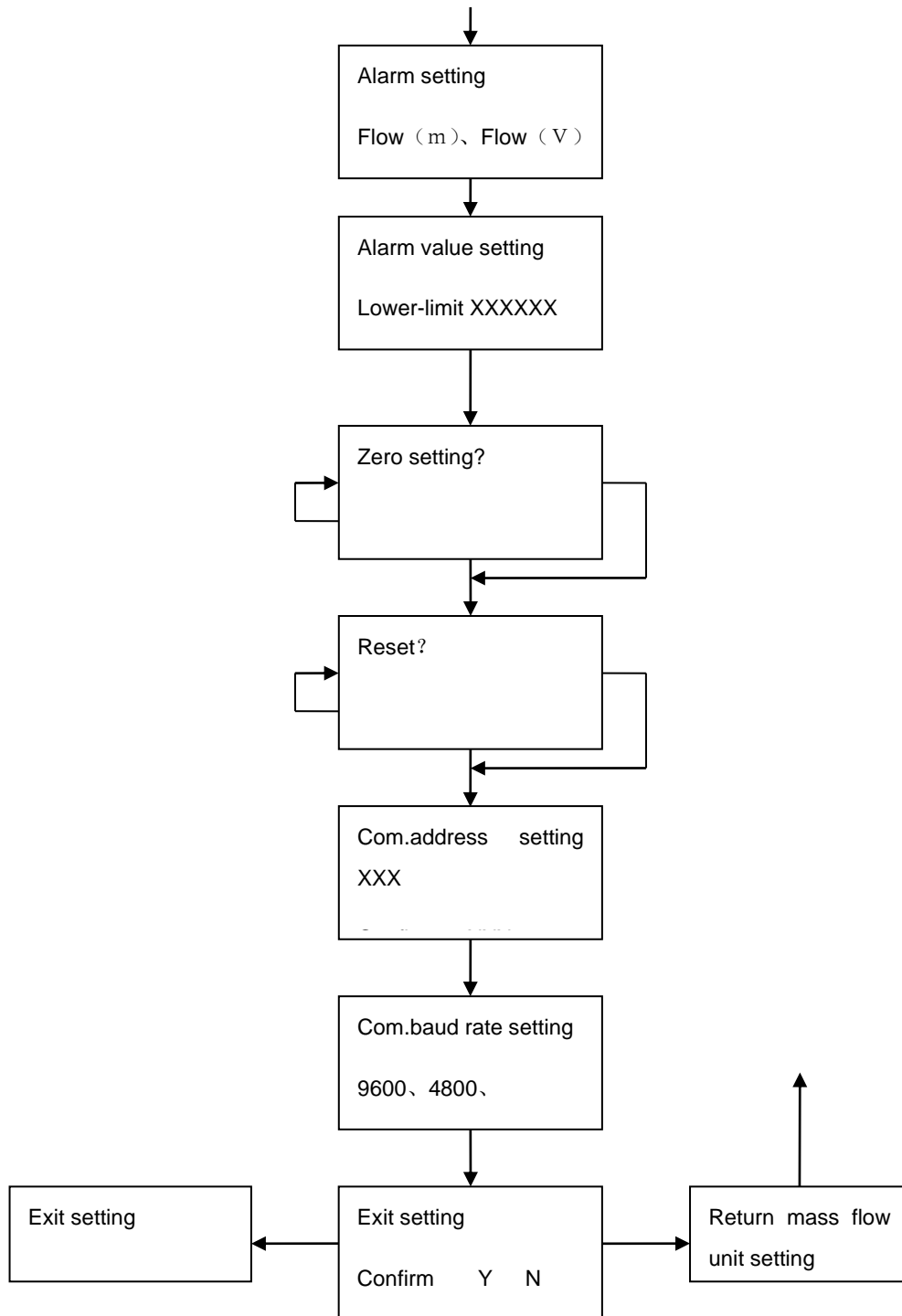

### 5.3.3 Output signal option setting

Output Signal Type	Output Signal Content
Pulse Output	1) When the flow meter is used for material measurement, pulse output is recommended. 2) Pulse frequency signal output 0-10000Hz corresponding to setting range, upper frequency can be set as 5KHz~10KHz 3) Equivalent pulse signal is to output a pulse signal corresponding to a certain flow, which is mainly used for flow integrating control, the frequency is 0.01~1000Hz.
Current Output	There is one way current output, which can be corresponding to the measurement of flow, density or temperature.

### 5.3.4 Alarm setting

Alarm setting include mass flow, volume flow, density and temperature, one of which can be selected for alarm setting. After setting alarm value, the meter will output alarm level signal and signal light flashes when the measurement value exceeds alarm setting value.

### 5.3.5 Zero adjustment

Normally, factory has finished zero adjustment, the users do not need to adjust zero at the field. But some time incorrect installation will cause great stress to make zero change, in this case, zero adjustment at the field is necessary. The requirement on the zero adjustment as below:

- 1) Make the measured fluid flow through the meter for 10 minutes;
- 2) Close the downstream and upstream valve after the pipe is full of fluid;
- 3) Make sure the fluid is static.

### 5.3.6 Total flow reset

The total flow will be saved after power off.

The previous flow records will be lost completely after total flow reset.

Total flow reset is required only when total flow requires special handling.



***Each time you change the unit of measurement, the total flow will automatically be cleared.***

### 5.3.7 Auxiliary function setting

Auxiliary function includes flow direction setting, normal pressure value setting, normal temperature value setting, gas standard flow value setting. Flow direction setting is as below:

Setting value	Description	Forward flow	Reverse flow	Total
0	bidirection	With signal output	With signal output	Forward: accumulative plus Reverse: accumulative minus
1	forward	With signal output	Without signal output	Forward: accumulative plus Reverse: No accumulative
2	reverse	Without signal output	Without signal output	Forward: No accumulative Reverse: accumulative minus
3	absolute	With signal output	With signal output	Forward: accumulative plus Reverse: accumulative plus

## 6. Calibration and Adjustment (Engineering parameter setting)

The calibration and adjustment for transmitter should be carried out in the laboratory.

The calibration parameter is set based on the result of calibration before delivery, including flow coefficient setting, density coefficient setting, temperature coefficient setting. So changing the coefficient of flowmeter may cause abnormal work.

The adjustment for flowmeter coefficient is carried out under engineering setting status. To enter engineering setting status safely, a password is required. The password can be reset by technical staff. (The lost of password will cause the trouble of work, so technical staff should save new password carefully).

Engineering setting menu is shown as below:

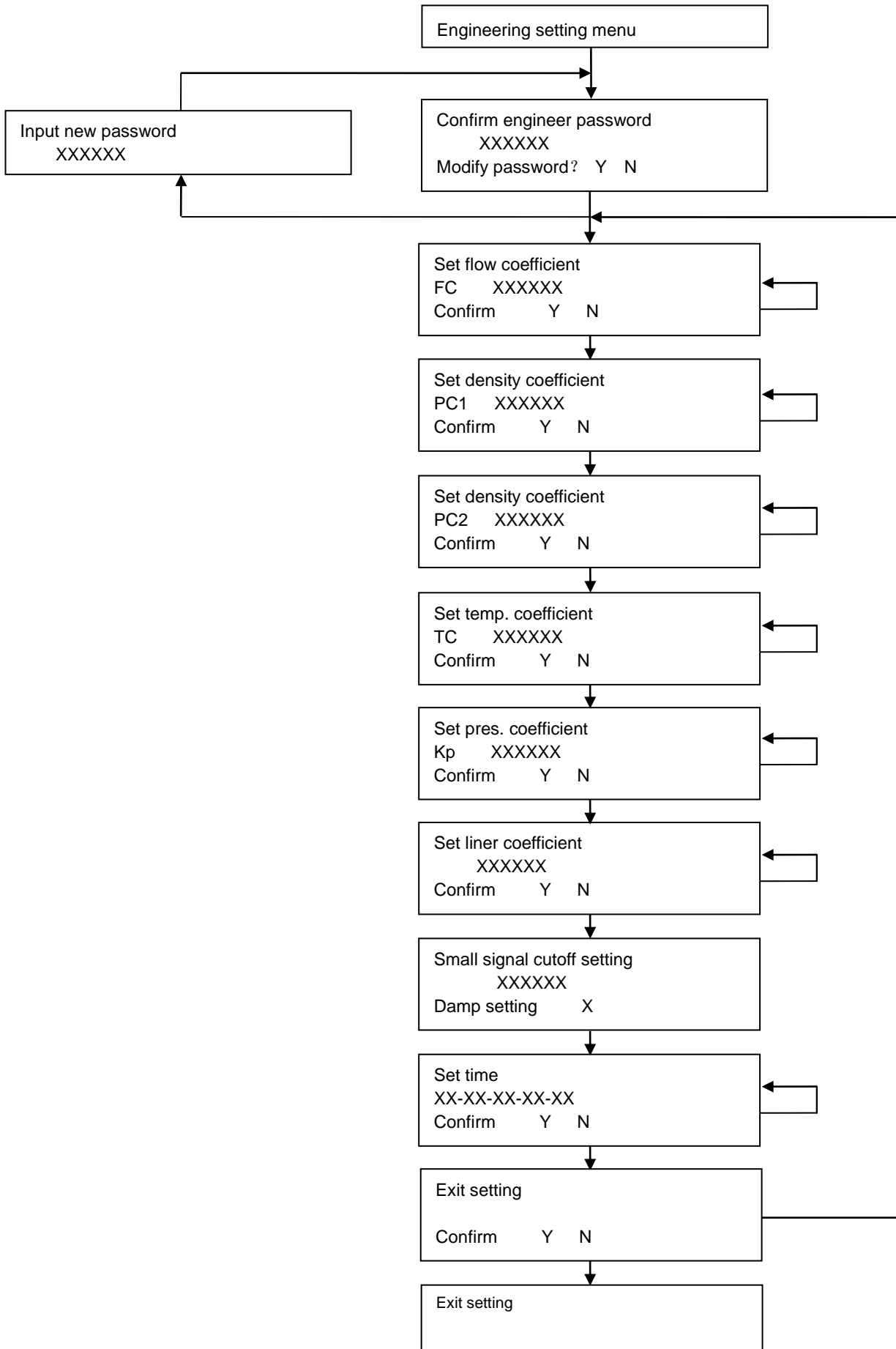



## 7.Attention for Anti-explosion

The main anti-explosion type of transmitter is flame-proof, The part connected with sensor is mounted with intrinsically safe measure to ensure the anti-explosion performance of sensor.

The housing of transmitter is aluminum alloy. There is sealing ring silicone rubber used in the connection between terminal cover and body、 the connection between the cover of transmitter display operation and body、 the connection between transmitter display window and body.

The transmitter external wiring cable should use 8mm cable. Cable access to the internal of flow meter through G1/2" gland nut, gasket and cable silicon seal. Lock nut after wiring to ensure cable sealed.

Connection cable between transmitter and sensor uses special cable with 10mm of external diameter. The cable wiring is connected well and sealed well before delivery. Please ensure not to destroy seal in use.

Safety barrier is mounted at wiring outlet between transmitter and sensor to ensure the anti-explosion performance of sensor.

For anti-explosion safe, sealed structure can't be destroyed in use.

You must cut off power supply if you need to open the cover of transmitter. Re-covering must ensure the seal of transmitter. Electrify after confirmation.

## 8. Model Selection

Model	Size (mm)	Flow Rang (Kg/h)	Model	Size (mm)	Flow Rang (Kg/h)
OI-CMF-003	3	0~96~120	OI-CMF-04	40	0~30 000~36 000
OI-CMF-006	6	0~540~660	OI-CMF-05	50	0~48 000~60 000
OI-CMF-008	8	0~960~1200	OI-CMF-06	65	0~64 000~80 000
OI-CMF-010	10	0~1500~1800	OI-CMF-08	80	0~120 000~160 000
OI-CMF-015	15	0~3000~4200	OI-CMF-10	100	0~222 000~270 000
OI-CMF-020	20	0~6000~7800	OI-CMF-15	150	0~480 000~600 000
OI-CMF-025	25	0~10200~13500			
OI-CMF-032	32	0~18 000~24 000			
<b>H</b>	<b>Structural Style</b>				
H1	Compact				
H2	Remote				
<b>P</b>	<b>Process Connection</b>				
P1	DIN PN25 (DN80~DN150)				
P2	DIN PN40 (DN3~DN65)				
P3	ANSI 150ibs				
P4	ANSI 3000ibs				
P5	Other (Special instructions)				
<b>M</b>	<b>Sensor Material</b>				
M1	Measuring Tube: S.S.316L, Shell: S.S.304.				
M2	Measuring Tube: S.S.316L, Shell: S.S.316L.				
M3	Other				
<b>T</b>	<b>Temperature Range</b>				
T1	(-50~200°C)				
T2	High Temperature Type (-50~350°C)				
T3	Low Temperature Type (-200~100°C) No Heating				
T4	Low Temperature with Heating				
<b>O</b>	<b>Output</b>				
O1	4~20mA, 0~10KHz				
O2	None				
<b>C</b>	<b>Communication Protocol</b>				
C1	RS485/MODBUS				
C2	HART				
C3	None				
<b>E</b>	<b>Explosion protection</b>				
E1	IP67&ExdiaIICt6 Gb				
E2	IP67 &No-explosion				
<b>A</b>	<b>Accuracy</b>				
A1	±0.1%				
A2	±0.15%				
A3	±0.2%				
A4	±0.5% (Gas)				
<b>P</b>	<b>Power supply</b>				
P1	18~36V.D.C				
P2	85~265V.A.C				