

SURGICAL CASSETTE TRS

instructions for use



- Recognizable tools with laser-marked titles for smooth procedures
- Comfortable handling due to ergonomic design
- Stable-fitted tools for safe transportation
- Single-handed opening mechanism
- Convenient bundle of tools
- Drill length check

For implant systems: **ROOTT R C C S M S**

CONTENT

Drills



DB2020 D2020 D2516 D2816 D3216 D3616 D4016 D4316 D4616 D5016 D5316 D5506

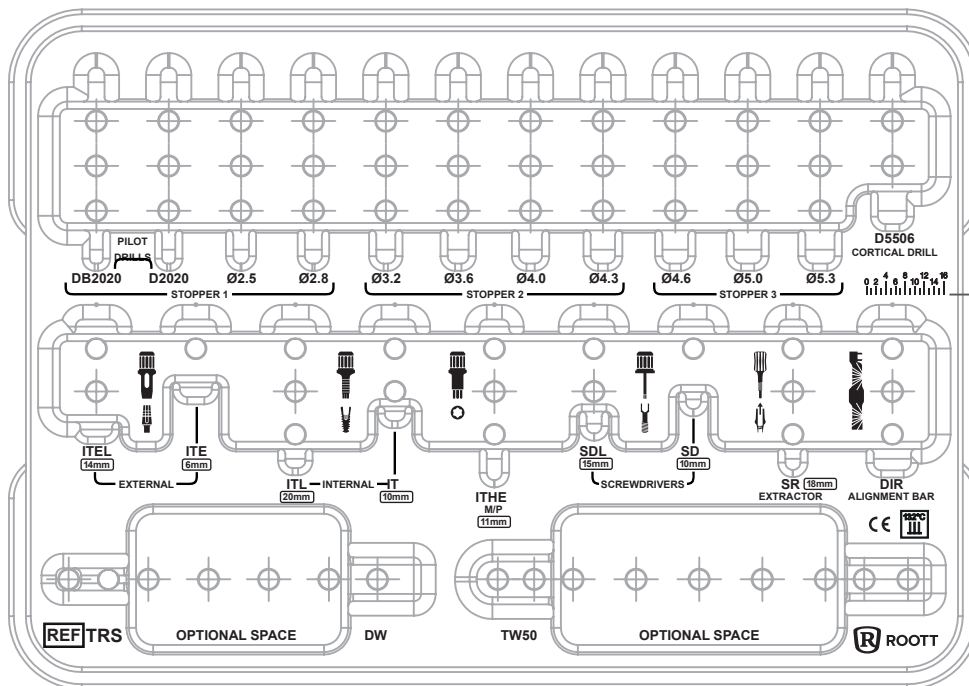

Drill length check

R C C S S

Implant drivers for external platform



ITE

ITEL

R

Implant drivers for internal platform



IT

ITL

M

Implant driver



ITHE

R M S

Screwdrivers



SD

SDL

R

Abutment extractor



SR

R C C S S M

Alignment bar



DIR

Handle for implant driver



DW

Torque wrench



TW50

Drills

Lance drill DB2020 can be used for initial drilling by setting the drilling axis before using tapered drills. Drill has laser markings every 2 mm from 6 to 20 mm.



Tapered drills are used for cavity preparation. Use a drill with a diameter lower than the diameter of the implant to be placed. Drill to the appropriate depth, required for a specific case. Laser markings every 2 mm from 4 to 16 mm.



Take a **twist pilot drill D2020** to define the direction of the implant and to enlarge diameter of the hole. Depth marks for easy visual reference while drilling or x-ray control.

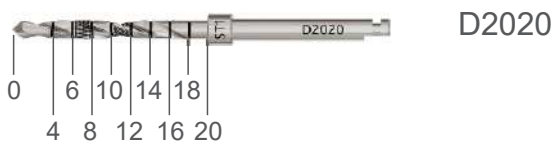

Drill D5506 is used for cortical drilling. As optional solution to widen the osteotomy.



Handle

For supporting implant drivers, that are used with a wrench



Torque wrench

Torque wrench is suitable for all instruments with head for ratchet. Maximal torque is 50 Ncm.



Implant drivers

For external platform. To control the implant insertion depth, have two lasered round lines at 2 and 4 mm.



For internal platform. Have length indicators.

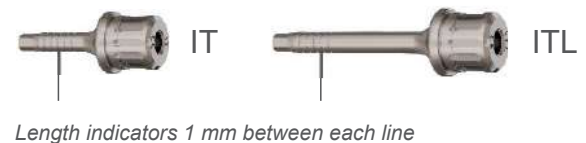

For M platform via carrier. Consists of two parts: implant driver and screwdriver.



Screwdrivers

For all ROOTT dental implant system screws. Long screwdriver is suitable for all superstructures. Conical tip of the hex helps to grab screw.

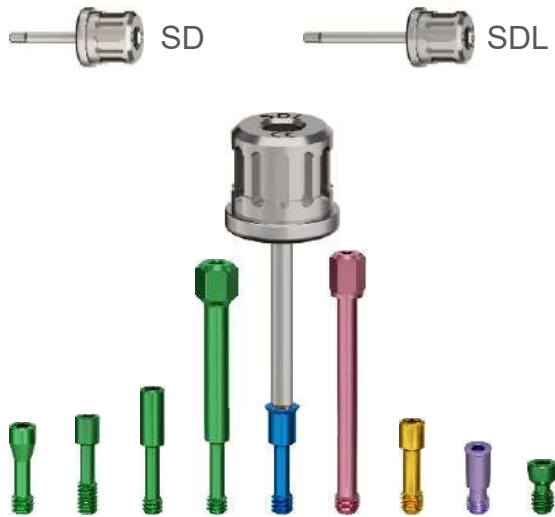

Alignment bar

Used for approximate measurement of abutment angle in relation to abutment next to it.

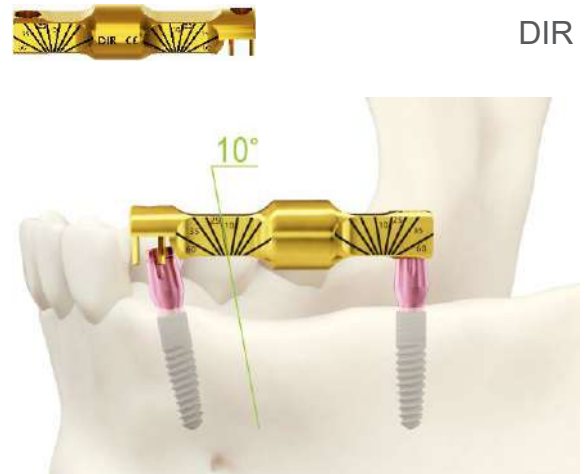

Abutment extractor

For easy superstructure removal in case if conical connection hold tight a part inside of ROOTT R implant

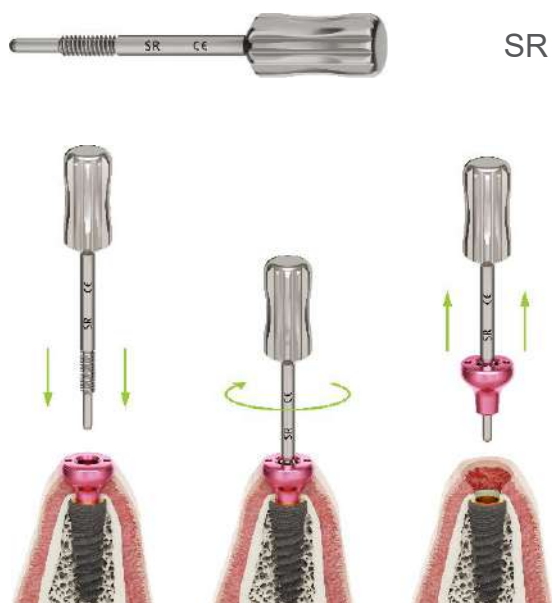

Example:

ROOTT R implant
 Ø 3.8 mm
 Length – 12 mm



R3812



DB2020 D2020 D2516 D2816 D3216 D3616 D5506

*Optional

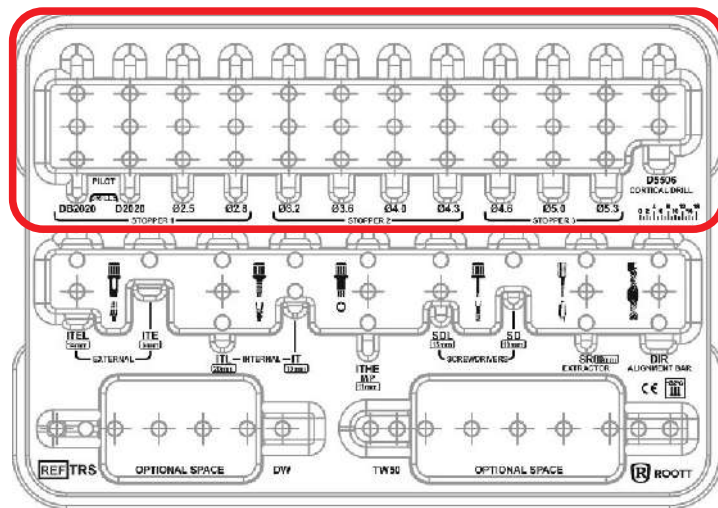

- Step 1** Take a lance drill DB2020 to make the first mark on the bone.
- Step 2** Use drill length check to check drill length. Use laser marking to identify position with regards to intraosseous length of implant. Drill deeper 0.5 mm then the implant length for subcrestal position.
- Step 3** Take a twist pilot drill D2020 to define the direction of the implant and to enlarge diameter of the hole.
- Step 4** Take a tapered drill D2516 to enlarge diameter of the hole. Use wider tapered drills to prepare hole for wider diameter implants.

**Optional*

If after using the previous drill the torque is still more than 50 Ncm while inserting the implant, the cavity has to be widened. Just widen the osteotomy with drill D5506.



Drilling protocol for ROOTT R implants or see Table 1

Implant	D4 BONE	D2-D3 BONE	D1 BONE
Ø 3.0 mm	DB2020 D2020	DB2020 D2020 D2516	DB2020 D2020 D2516 D2816
Ø 3.5 mm	DB2020 D2020 D2516	DB2020 D2020 D2516 D2816	DB2020 D2020 D2516 D2816 D3216
Ø 3.8 mm	DB2020 D2020 D2516 D2816	DB2020 D2020 D2516 D2816 D3216	DB2020 D2020 D2516 D2816 D3216 D3616
Ø 4.2 mm	DB2020 D2020 D2516 D2816 D3216	DB2020 D2020 D2516 D2816 D3216 D3616	DB2020 D2020 D2516 D2816 D3216 D3616 D4016
Ø 4.8 mm	DB2020 D2020 D2516 D2816 D3216 D3616 D4016	DB2020 D2020 D2516 D2816 D3216 D3616 D4016 D4316	DB2020 D2020 D2516 D2816 D3216 D3616 D4016 D4316 D4616
Ø 5.5 mm	DB2020 D2020 D2516 D2816 D3216 D3616 D4016 D4316 D4616	DB2020 D2020 D2516 D2816 D3216 D3616 D4016 D4316 D4616 D5016	DB2020 D2020 D2516 D2816 D3216 D3616 D4016 D4316 D4616 D5016 D5316

Table 1

Example:
 ROOTT R implant
 Ø 3.8 mm
 Length – 12 mm

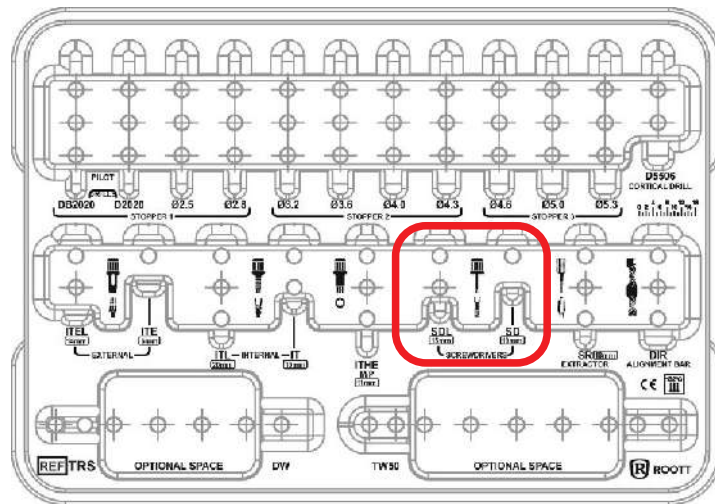
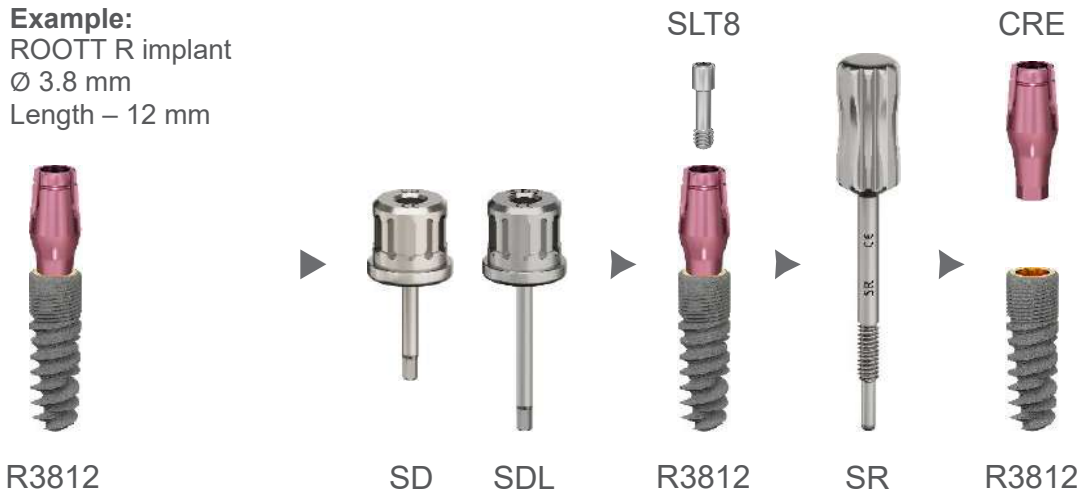

- Step 1** Take a multipurpose screwdriver SD or SDL for screwing & unscrewing any screw of ROOTT dental implant system. Due to the conical tip of the hex, it is more manageable to take out the screw from the superstructure. Therefore if struggling to remove the screw from the abutment, movement side to side before pulling out is allowed.
- Step 2** Unscrew screw SLT8 from CRE.
- Step 3** Take an abutment extractor SR. Screw SR instead of your screw until part will not be released and remove CRE.

Abutment extractor SR – for easy superstructure removing in case if your conical connection hold tight a part inside of ROOTT R implant.

Example:
 ROOTT R implant
 Ø 3.8 mm
 Length – 12 mm

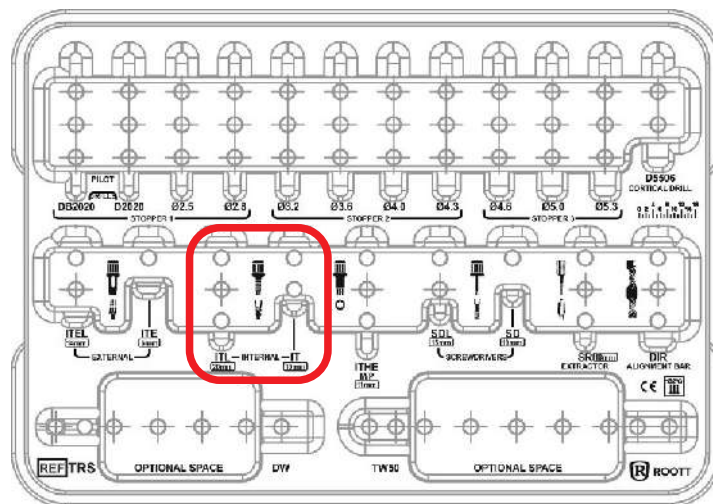

Step 1 Take an implant driver for internal platform IT/ITL for inserting ROOTT R implants when the carrier part is removed.

Step 2 Place IT/ITL to torque wrench TW50 and insert implant to the prepared hole. When the set torque is reached. The scale sleeve snaps around the axis in the wrench head. The release can be heard and felt. Do not continue to use the wrench after the torque is achieved. The wrench or dental components could be damaged.



Step 3 Use handle for implant driver DW for more precise implant insertion and to avoid glove grab.



For detailed information please read ROOTT R implant placement protocol



Example:
 ROOTT R implant
 Ø 3.8 mm
 Length – 12 mm



R3812



DIR

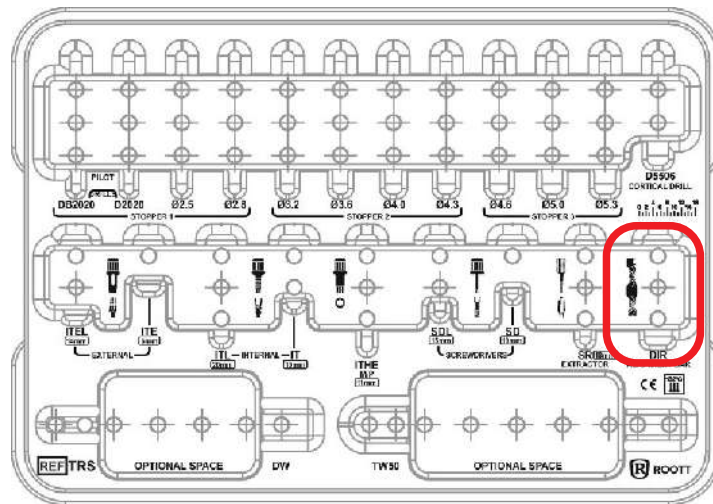

The implants can be relatively parallel or not parallel. Most dental implants systems require parallelism within approximately 10 degrees to function properly. Non-parallel implant placement may preclude the use of anatomical abutments. For such cases can be used angled abutments.

- Step 1** Take an alignment bar.
- Step 2** Mount on implant with CRE.
- Step 3** Check angulation between two implants. It allows to preplan the use of the angled abutments to achieve maximum parallelism. If angle between two ROOTT R implants is:
- a) 10° use two ROOTT R anatomical or telescopic abutments;
 - b) 25° use ROOTT R anatomical or telescopic and 15° angled telescopic abutment;
 - c) 35° use ROOTT R anatomical or telescopic and straight multiunit abutment.
 - d) if angle is greater then mentioned above, should be used angled abutments.

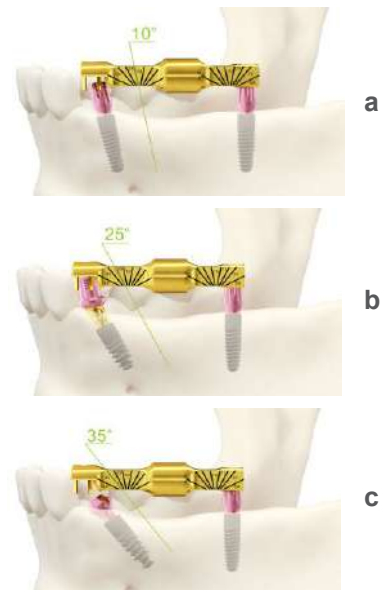

Example:
 ROOTT C implant
 Ø 4.0
 Length – 12 mm



C4012



DB2020 D2020 D2516 D2816 D3216 D5506

*Optional

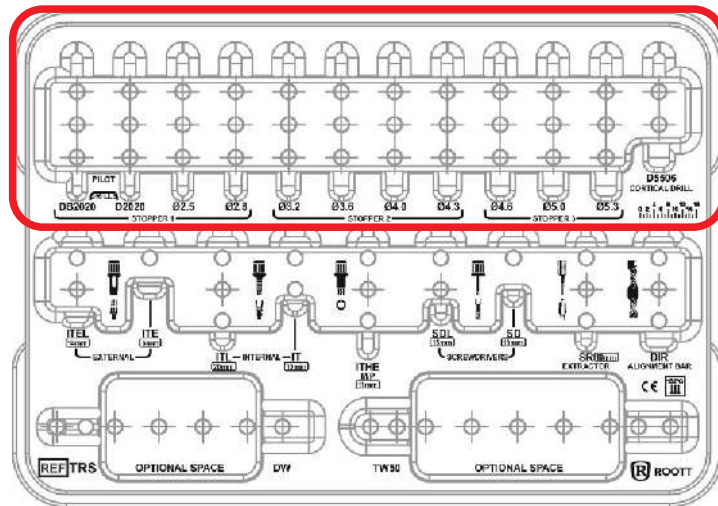

- Step 1** Take a lance drill DB2020 to make the first mark on the bone.
- Step 2** Use drill length check to check drill length. Use laser marking to identify position with regards to the intraosseous length of the implant. Drill to the required length (see Table 2 or drilling protocol for ROOTT C/CS).
- Step 3** Take a twist pilot drill D2020 to define the direction of the implant and to enlarge diameter of the hole.
- Step 4** Take a tapered drill D2516 to enlarge the diameter of the hole. Use wider tapered drills to prepare the hole for wider diameter implants.

**Optional*

If after using the previous drill the torque is still more than 50 Ncm while inserting the implant, the cavity has to be widened. Just widen the osteotomy with drill D5506.



Drilling protocol for ROOTT C/CS implants or see Table 2

Implant	D4 bone		D2-D3 bone		D1 bone		*drill to depth as specified
	Ø 3.0 mm	DB2020		DB2020 D2020*		DB2020 D2020 D2516*	
Ø 3.5 mm	DB2020 D2020		DB2020 D2020 D2516*		DB2020 D2020 D2516* D2816*		C3506, C3508 - 4 mm * C3510, C3512 - 6 mm C3514, C3516 - 8 mm C3518, C3520 - 10 mm
Ø 4.0 mm	6-20 mm DB2020 D2020* D2516*		6-20 mm DB2020 D2020 D2516* D2816*		6-8 mm 10-20 mm DB2020 DB2020 D2020 D2020 D2516 D2516* D2816* D2816* D3216* D3216*		C4006, C4008 - 4 mm * C4010, C4012 - 6 mm C4014, C4016 - 8mm C4018, C4020 - 10 mm
Ø 4.5 mm	6-20 mm DB2020 D2020 D2516* D2816*		6-20 mm DB2020 D2020 D2516 D2816* D3216*		6-8 mm 10-20 mm DB2020 DB2020 D2020 D2020 D2516 D2516 D2816 D2816* D3216* D3216* D3616* D3616*		C4506, C4508 - 4 mm * C4510, C4512 - 6 mm C4514, C4516 - 8 mm C4518, C4520 - 10 mm
Ø 5.0 mm	6-8 mm 10-14 mm DB2020 DB2020 D2020 D2020 D2516 D2516* D2816 D2816* D3216 D3216*		6-8 mm 10-14 mm DB2020 DB2020 D2020 D2020 D2516 D2516 D2816 D2816* D3216 D3216* D3616 D3616*		6-8 mm 10-14 mm DB2020 DB2020 D2020 D2020 D2516 D2516 D2816 D2816 D3216 D3216* D3616 D3616* D4016 D4016*		C5006, C5008 - 4 mm * C5010, C5012 - 6 mm C5014 - 8 mm
Ø 5.5 mm	6-8 mm 10-14 mm DB2020 DB2020 D2020 D2020 D2516 D2516* D2816 D2816* D3216 D3216* D3616 D3616* D4016* D4016*		6-8 mm 10-14 mm DB2020 DB2020 D2020 D2020 D2516 D2516 D2816 D2816* D3216 D3216* D3616 D3616* D4016 D4016* D4316* D4316*		6-8 mm 10-14 mm DB2020 DB2020 D2020 D2020 D2516 D2516 D2816 D2816 D3216 D3216* D3616 D3616* D4016 D4016* D4316 D4316* D4616* D4616*		C5506, C5508 - 4 mm * C5510, C5512 - 6 mm C5514 - 8 mm

Table 2

Example:
 ROOTT C implant
 Ø 4.0
 Length – 12 mm

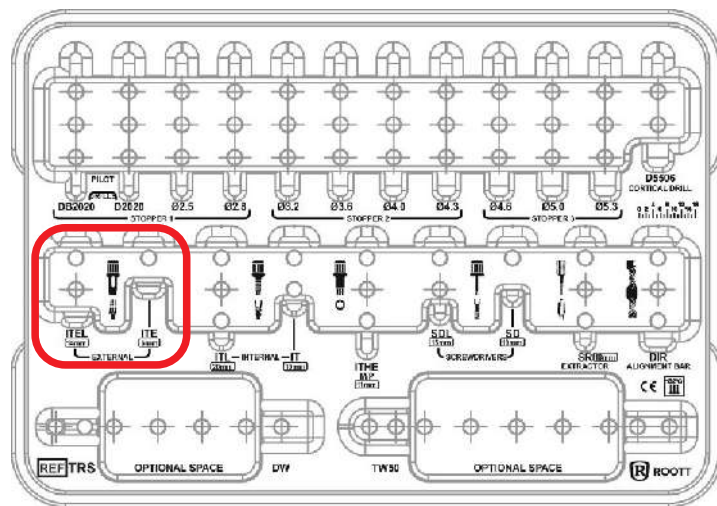

Step 1 Take an implant driver for external platform ITE/ITEL for inserting implant via direct insertion.

Step 2 Place ITE/ITEL to torque wrench TW50 and insert implant to the prepared hole. When the set torque is reached, the scale sleeve snaps around the axis in the ratchet head. The release can be heard and felt.



Do not continue to use the wrench after the torque is achieved. The wrench or dental components could be damaged.

Step 3 Use handle for implant driver DW for more precise implant insertion and to avoid glove grab.



For detailed information please read ROOTT C/CS implant placement protocol



Example:
 ROOTT C implant
 Ø 4.0
 Length – 12 mm



C4012



DIR

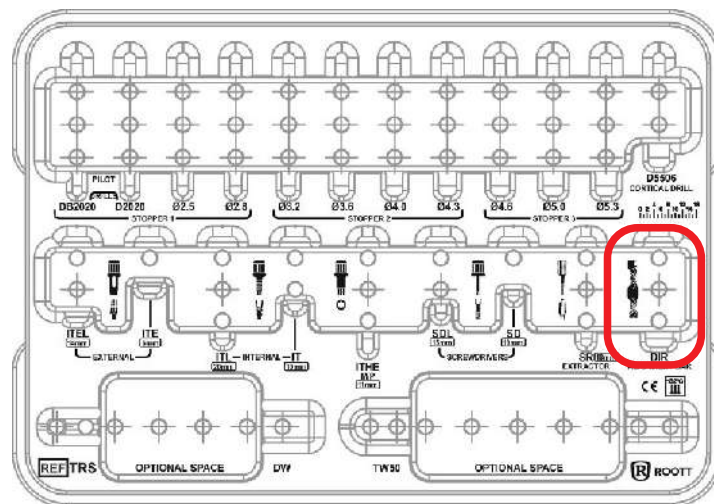

The implants can be relatively parallel or not parallel. Most dental implants systems require parallelism within approximately 10 degrees to function properly. Non-parallel implant placement may preclude the use of anatomical abutments. For such cases can be used angled abutments.

- Step 1** Take an alignment bar.
- Step 2** Mount on implant.
- Step 3** Check angulation between two implants. It allows to pre-plan the use of the angled abutments to achieve maximum parallelism. If angle between two ROOTT C implants is 10° use telescopic abutments.



ROOTT C implants can be combined with ROOTT R or ROOTT M/P/S implants.

Example:

ROOTT M implant
 Ø 4.0
 Length – 12 mm



C4012m

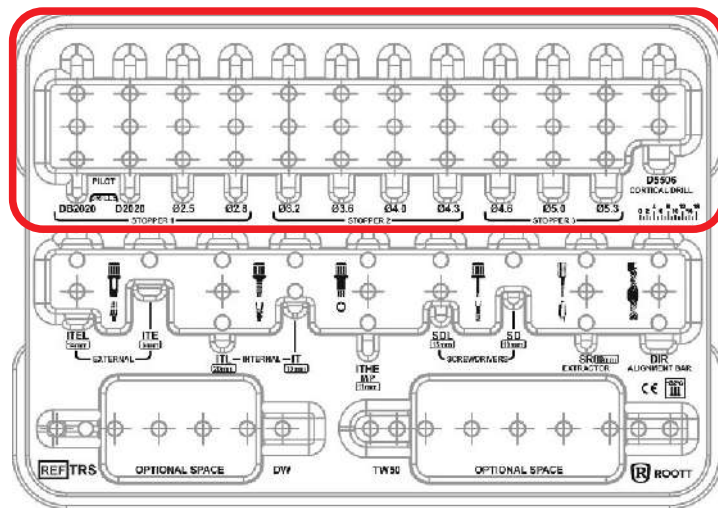

- Step 1** Take a lance drill DB2020 to make the first mark on the bone.
- Step 2** Use drill length check to check drill length. Use laser marking to identify position with regards to the intraosseous length of the implant. Drill to the required length (see table 3 or Drilling protocol for ROOTT M implants).
- Step 3** Take a twist pilot drill D2020 to define the direction of the implant and to enlarge diameter of the hole.
- Step 4** Take a tapered drill D2516 to enlarge the diameter of the hole. Use wider tapered drills to prepare the hole for wider diameter implants.

**Optional*

If after using the previous drill the torque is still more than 50 Ncm while inserting the implant, the cavity has to be widened. Just widen the osteotomy with drill D5506.



Drilling protocol for ROOTT M implants or see Table 3

Implant	D4 BONE	D2-D3 BONE	D1 BONE	*drill to depth as specified
Ø 3.0 mm	DB2020	DB2020 D2020*	DB2020 D2020* D2516*	C3008ms/C3008m - 4 mm, C3010ms/C3010m, C3012ms/C3012m - 6 mm, C3014ms/C3014m, C3016ms/C3016m - 8mm, C3018m, C3020m - 10 mm
Ø 3.5 mm	DB2020 D2020*	DB2020 D2020* D2516*	DB2020 D2020* D2516* D2816*	C3508ms/C3508m - 4 mm, C3510ms/C3510m, C3512ms/C3512m - 6 mm, C3514ms/C3514m, C3516ms/C3516m - 8mm, C3518m, C3520m - 10 mm
Ø 4.0 mm	DB2020 D2020* D2516* D2816*	DB2020 D2020 D2516* D2816* D3216*	DB2020 D2020 D2516 D2816* D3216* D3616*	C4006m, C4008m - 4 mm C4010m, C4012m - 6 mm C4014m, C4016m - 8mm
Ø 5.0 mm	DB2020 D2020 D2516 D2816* D3216* D3616* D4016*	DB2020 D2020 D2516 D2816 D3216* D3616* D4016* D4316*	DB2020 D2020 D2516 D2816 D3216 D3616* D4016* D4316* D4616*	C5006m, C5008m - 4 mm C5010m, C5012m - 6 mm C5014m - 8mm
Ø 6.0 mm	DB2020 D2020 D2516 D2816 D3216 D3616* D4016* D4316* D4616*	DB2020 D2020 D2516 D2816 D3216 D3616* D4016* D4316* D4616* D5016*	DB2020 D2020 D2516 D2816 D3216 D3616 D4016* D4316* D4616* D5016* D5316*	C6006m, C6008m - 4 mm C6010m, C6012m - 6 mm C6014m - 8mm

Table 3

Example:
 ROOTT M implant
 Ø 4.0
 Length – 12 mm



C4012m



ITHE + SITHE

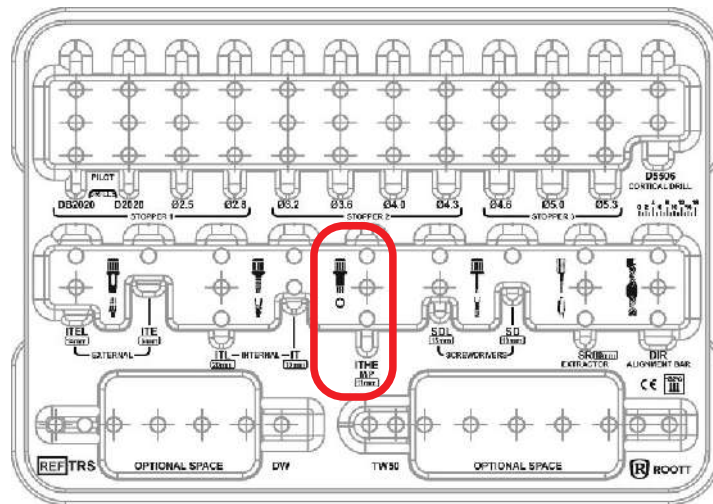

Step 1 Take an implant driver ITHE for inserting ROOTT M implants via the carrier.

Step 2 Place ITHE to torque wrench TW50 and insert implant to the prepared hole. When the set torque is reached, the scale sleeve snaps around the axis in the ratchet head. The release can be heard and felt.



Do not continue to use the wrench after the torque is achieved. The wrench or dental components could be damaged.

Example:
 ROOTT M implant
 Ø 4.0
 Length – 12 mm

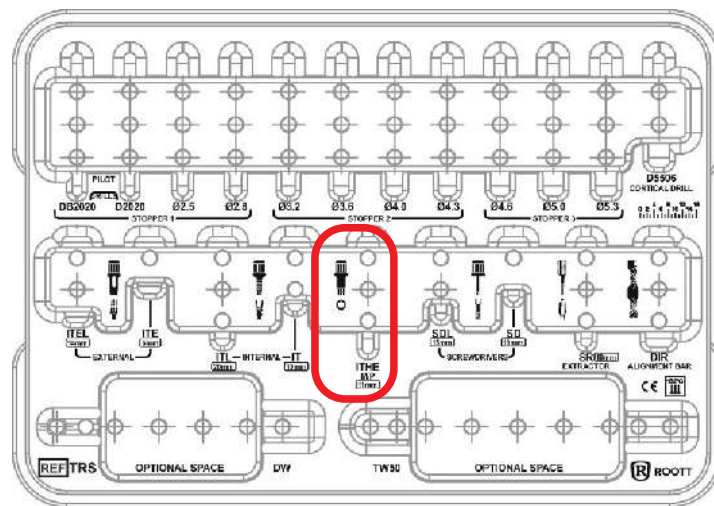
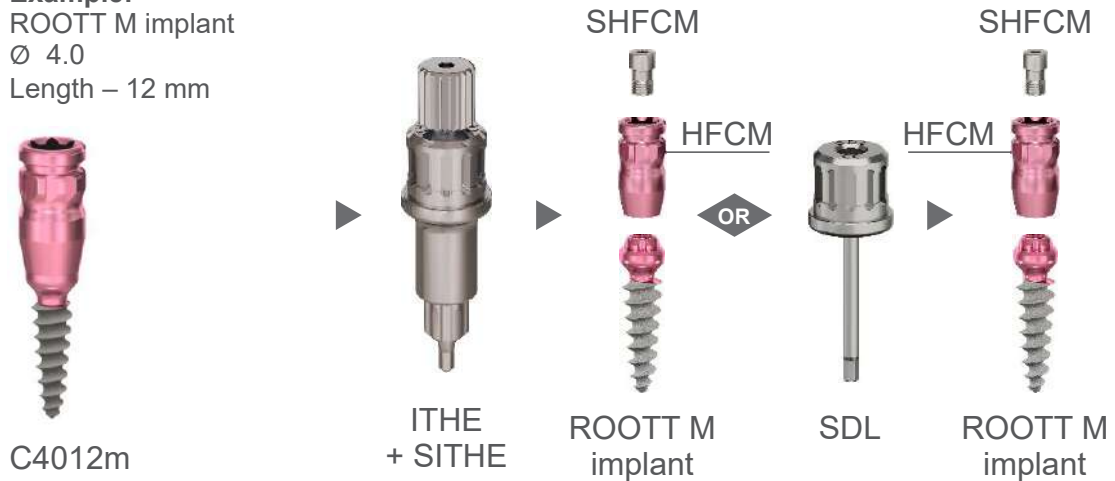

Step 1a Carrier can be removed without removing the implant driver ITHE using its screwdriver. Use screwdriver SITHE to unscrew SHFCM screw and remove carrier HFCM.

Step 1b Take a multipurpose screwdriver SD or SDL for screwing & unscrewing any screw of ROOTT dental implant system. Due to the conical tip of the hex, it is more manageable to take out the screw from the superstructure. Therefore if struggling to remove the screw from the abutment, movement side to side before pulling out is allowed.

Step 2 Unscrew screw SHFCM and remove carrier HFCM.

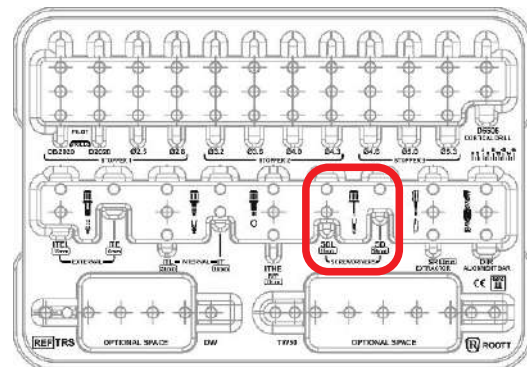

Example:
 ROOTT M implant
 Ø 4.0
 Length – 12 mm



C4012m



DIR

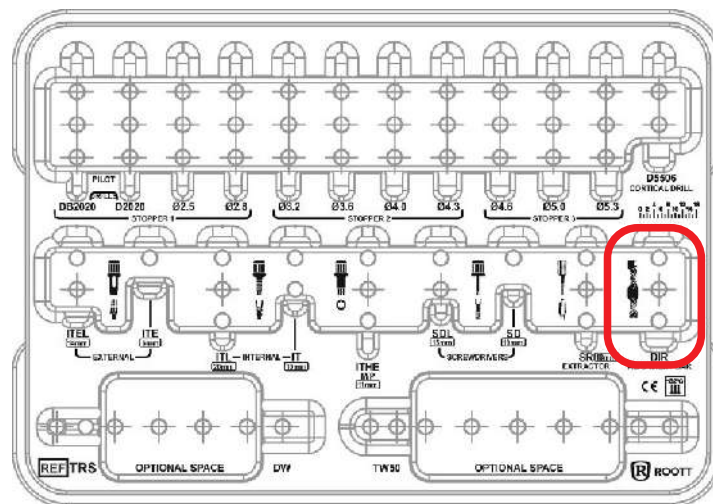

The implants can be relatively parallel or not parallel. For multi units require parallelism within approximately 60 degrees to function properly. Non-parallel implant placement may preclude the use of multi unit implants. For such cases can be used different combinations with other ROOTT dental implants.

- Step 1** Take an alignment bar.
- Step 2** Mount on implant with carrier HFCM.
- Step 3** Check angulation between two implants. It allows to preplan the use of the angled abutments or different combinations of implants to achieve maximum parallelism.

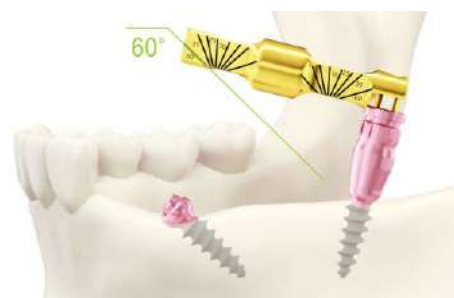

Between two ROOTT M implants can be 60° angle.
 ROOTT M implants can be combined with ROOTT R,
 ROOTT S or ROOTT C/CS implants.

Example:
 ROOTT S implant
 Ø 3.0
 Length – 12 mm



C3012ms

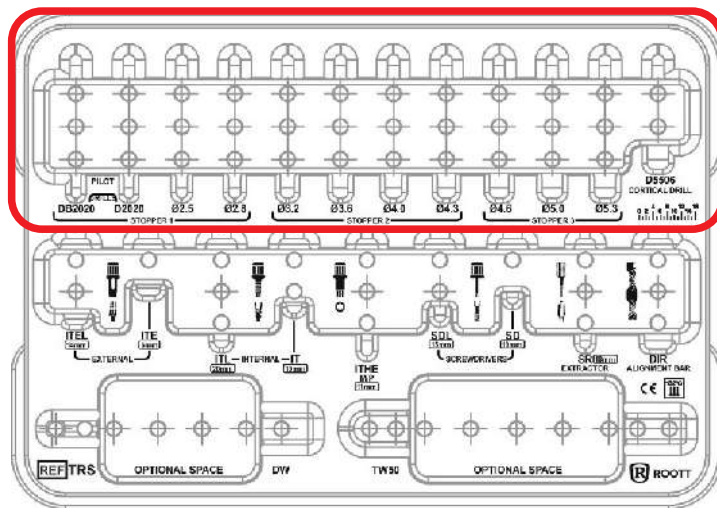

- Step 1** Take a lance drill DB2020 to make the first mark on the bone.
- Step 2** Use drill length check to check drill length. Use laser marking to identify position with regards to the intraosseous length of the implant. Drill to the same required length (see table 4 or Drilling protocol for ROOTT S).
- Step 3** Take a twist pilot drill D2020 to define the direction of the implant and to enlarge diameter of the hole.
- Step 4** Take a tapered drill D2516 to enlarge the diameter of the hole. Use wider tapered drills to prepare hole for wider diameter implants.

**Optional*
 If after using the previous drill the torque is still more than 50 Ncm while inserting the implant, the cavity has to be widened. Just widen the osteotomy with drill D5506.



Full drilling protocol for ROOTT S implants or see Table 4

Implant	D4 BONE	D2-D3 BONE	D1 BONE	*drill to depth as specified
Ø 3.0 mm	DB2020	DB2020 D2020*	DB2020 D2020* D2516*	C3008ms - 4 mm, C3010ms, C3012ms - 6 mm, C3014ms, C3016ms - 8mm
Ø 3.5 mm	DB2020 D2020*	DB2020 D2020* D2516*	DB2020 D2020* D2516*	C3508ms - 4 mm, C3510ms, C3512ms - 6 mm, C3514ms, C3516ms - 8mm

Table 4

Example:
 ROOTT S implant
 Ø 3.0
 Length – 12 mm



C3012ms



ITE



ITEL

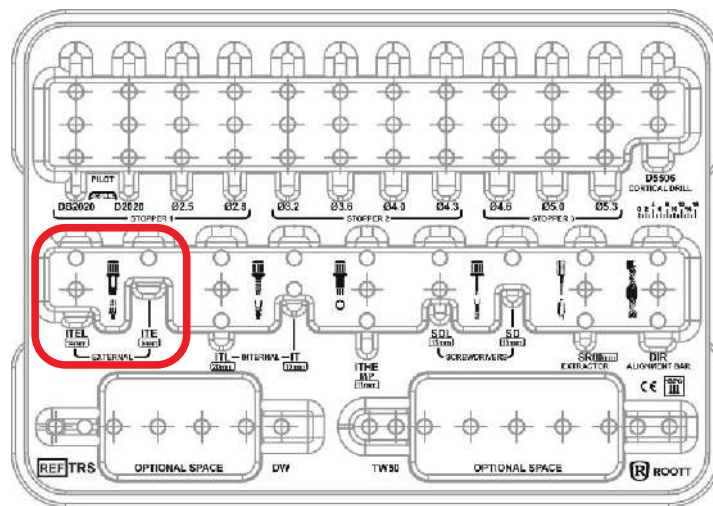

Step 1 Take an implant driver for external platform ITE/ITEL for inserting an implant via the carrier.

Step 2 Place ITE/ITEL to torque wrench TW50 and insert implant to the prepared hole. When the set torque is reached, the scale sleeve snaps around the axis in the ratchet head. The release can be heard and felt.



Do not continue to use the wrench after the torque is achieved. The wrench or dental components could be damaged.

Step 3 Use handle for implant driver DW for more precise implant insertion and to avoid glove grab.



Example:
 ROOTT S implant
 Ø 3.0
 Length – 12 mm

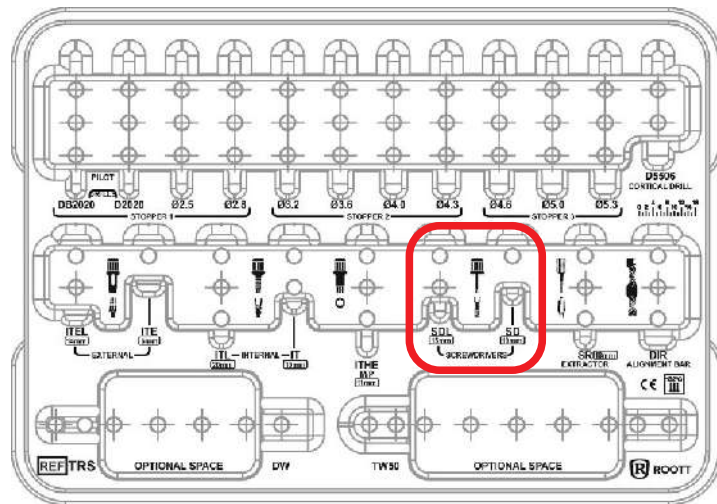
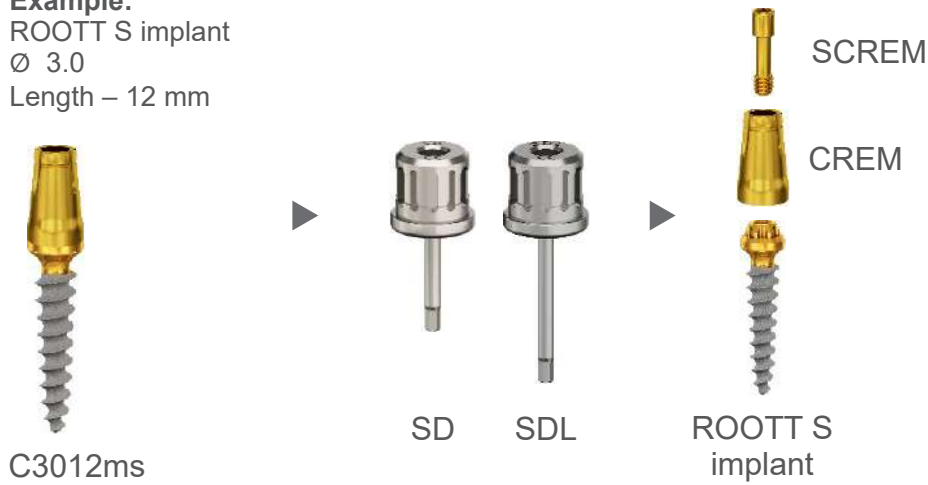

Step 1 Take a multipurpose screwdriver SD or SDL for screwing & unscrewing any screw of ROOTT dental implant system.

Due to the conical tip of the hex, it is more manageable to take out the screw from the superstructure. Therefore if struggling to remove the screw from the abutment, movement side to side before pulling out is allowed.

Step 2 Unscrew screw SCREM and remove carrier CREM.



Example:
 ROOTT S implant
 Ø 3.0
 Length – 12 mm



C3012ms



DIR

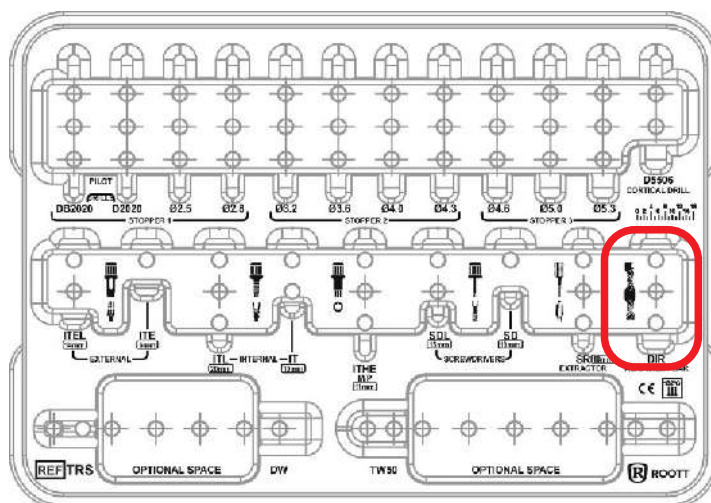

The implants can be relatively parallel or not parallel. For multi units require parallelism within approximately 60 degrees to function properly. Non-parallel implant placement may preclude the use of multi unit implants. For such cases can be used different combinations with other ROOTT dental implants.

- Step 1** Take an alignment bar.
- Step 2** Mount on implant with carrier CREM.
- Step 3** Check angulation between two implants. It allows to preplan the use of the angled abutments or different combinations of implants to achieve maximum parallelism.



Between two ROOTT S implants can be 60° angle.
 ROOTT S implants can be combined with ROOTT R,
 ROOTT M/P or ROOTT C/CS implants.



ROOTT

TRATE AG
Bahnhofstrasse 16
6037 Root
Switzerland

+41 41 450 01 01
info@trate.com
trate.com

TRATE

Medical devices under these instructions are in compliance with established in EU regulatory requirements.

