

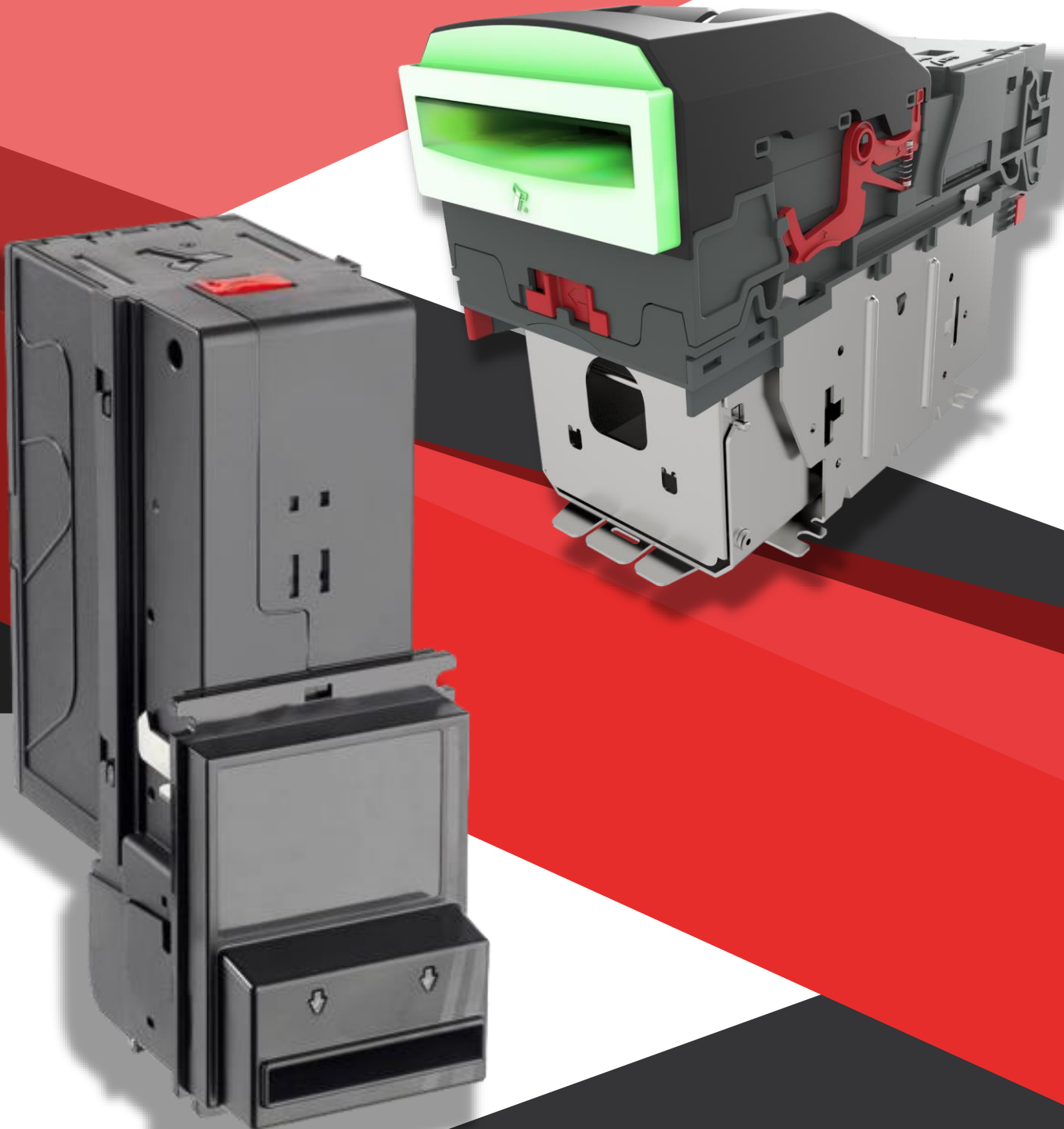

Innovative Technology

INTELLIGENCE IN VALIDATION



**Product
&
Service**



Innovative Technology

INTELLIGENCE IN VALIDATION

BV30

"The next generation compact bill acceptor"



- Attractive bezel illumination (RGB options)
- Exceptional value
- Enhanced sensing & security
- Ideal for low value transactions



FEATURES

- Improved optical & mechanical anti-strimming
- Improved note sensing - UV & reflective
- Exceptional value
- Proven field reliability
- Easy maintenance, free firmware updates, remote download SMART data compatible
- Faster note processing
- Attractive, compact design



BENEFITS

- Enhanced security
- Genuine note detection and protects against fraudulent notes
- A bill acceptor for the price of a coin mech
- Lowest cost of ownership
- Future proof
- Takes more cash
- Ideal for low value transactions



**Product
&
Service**

Technical Specification

Power

Requirements: 12V
Standby: 150mA
Running: 540mA
Peak: 1.5A

Bezel

72mm illuminated

Protocols

SSP
ccTalk
MDB
Pulse
Parallel
Binary
Serial

Interfaces

Open collector

MCBF

100,000

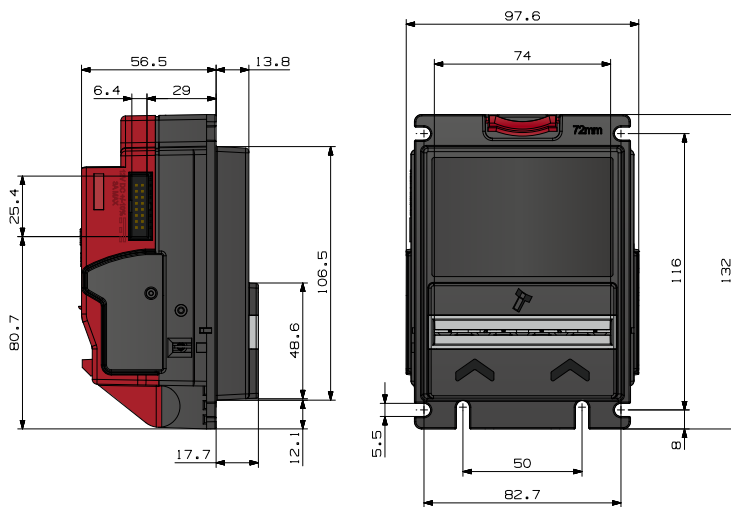

- Weight: 300g

**VIEW MORE
NOTE HANDLING
PRODUCTS >>**

PRODUCT & SERVICE srl

Via IV Novembre, 54

20019- SETTIMO MILANESE (MI)

TEL. +39 0233497446

info@product.it

www.vendingproduct.com



**Product
&
Service**



Innovative Technology

INTELLIGENCE IN VALIDATION

BV50

“Designed for 66mm bills”



- Designed specifically for 66mm bills
- Cashbox options to suit all applications
- Quick transactions
- Ideal for amusement & vending applications



FEATURES

- Fixed 66mm width bezel
- Proven field reliability
- Exceptional value
- Easy maintenance, free firmware updates
- MDB power supply unit & 110V options



BENEFITS

- Designed specifically for single width bills
- Lowest cost of ownership
- Fast repayment of initial investment
- Future proof - quick & easy updates via PC or handheld programmer
- Ideal for amusement & vending applications



**Product
&
Service**

Technical Specification

Power

Requirements: 12V
Standby: 0.4A
Running: 1.5A
Peak: 3A

Bezel Options

66mm width

Protocols

SSP
ccTalk
MDB
Pulse
Parallel
Binary
Serial

Interfaces

Open collector

Cashbox Options

300 bills
550 bills
800 bills
1050 bills

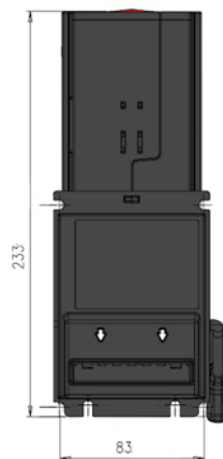
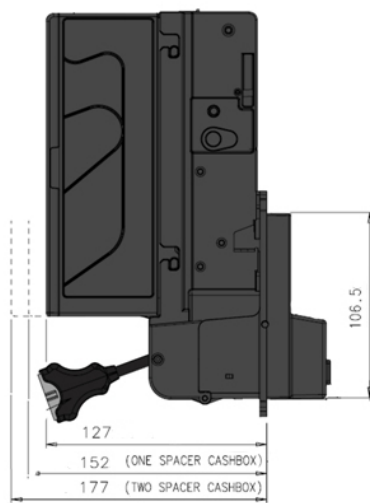

- Weight: 0.8kg

**VIEW MORE
NOTE HANDLING
PRODUCTS >>**

PRODUCT & SERVICE srl

Via IV Novembre, 54

20019- SETTIMO MILANESE (MI)

TEL. +39 0233497446

info@product.it

www.vendingproduct.com



**Product
&
Service**



Innovative Technology

INTELLIGENCE IN VALIDATION

NV9 USB

“Enhanced sensing technology”

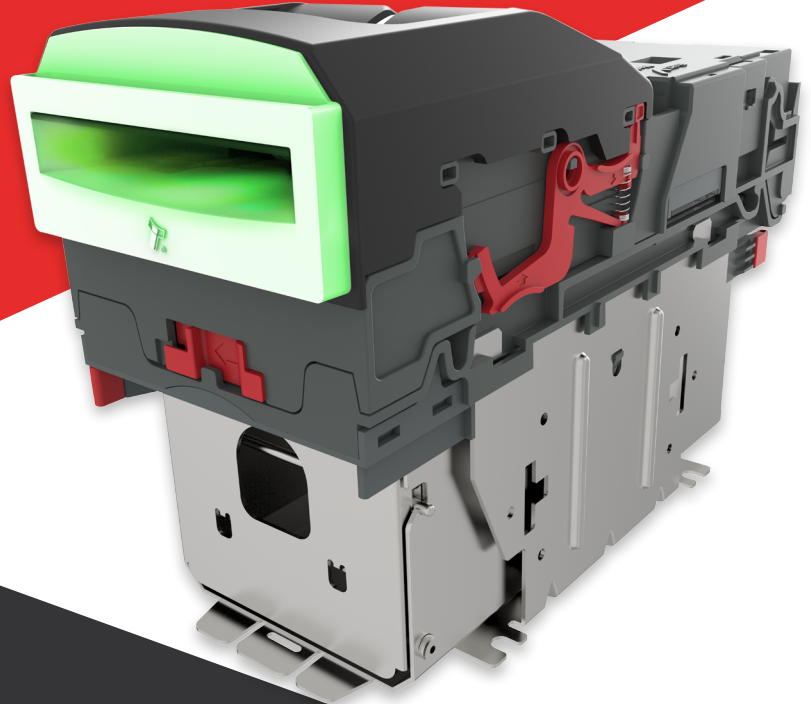

- Exceptional field reliability
- Enhanced sensing technology
- Cashbox & bezel options to suit all applications
- Future proof
- Modular design - recycler or ticket printer available



FEATURES

- Various cashbox and bezel options
- Proven field reliability
- Enhanced sensing technology = high acceptance rate for multi-currency
- Easy maintenance, free firmware updates
- Over 100 different world currencies accepted
- Modular design - recycler or ticket printer available



BENEFITS

- Versatile validator, suitable for all applications
- Lowest cost of ownership
- Takes more cash
- Future proof - quick & easy updates via USB, PC or handheld programmer
- A truly global product
- Ability to add note recycling or ticketing



**Product
&
Service**

Technical Specification

Power

Requirements: 12V
Standby: 0.2A
Running: 1A
Peak: 1.5A

Interfaces

USB option
Open collector

Protocols

SSP* Parallel
ccTalk* Binary
MDB* Serial*
Pulse

Bezel Options

66/69/82mm width Vertical up/down
Various snout options Horizontal
Rainbow illumination options*

Cashbox Options

300/600 slide
300/600 clip
300 lockable
Stackerless

MCBF

200,000

* Rainbow illumination bezel compatible with serial protocols only

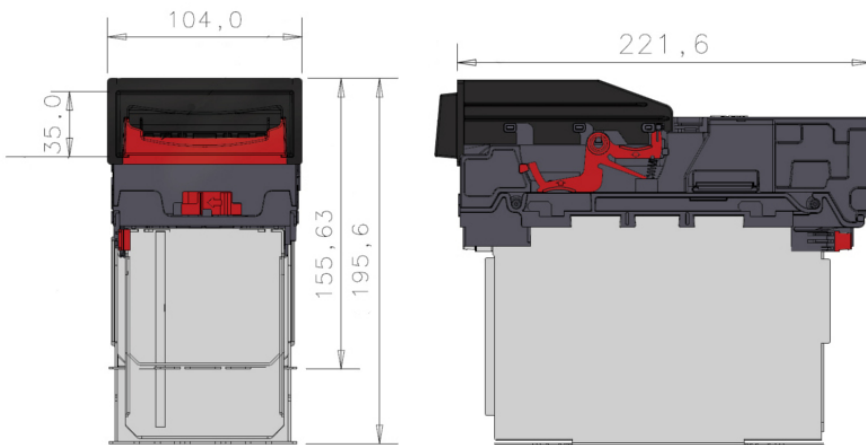

- Weight: 1.7kg

VIEW MORE
NOTE HANDLING
PRODUCTS >>

NV9-USB 304

Cash Box

300 Clip On (PA00185)

Bezel

Vertical Up Snout (PA00190)

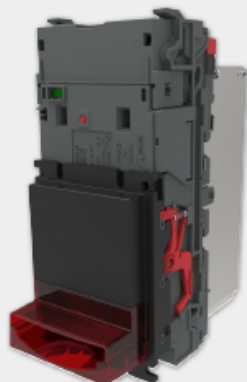

NV9-USB 404

Cash Box

600 Clip On (PA00193)

Bezel

Vertical Up Snout (PA00190)





Innovative Technology

INTELLIGENCE IN VALIDATION

NV10 USB

“Compact stackerless banknote validator”

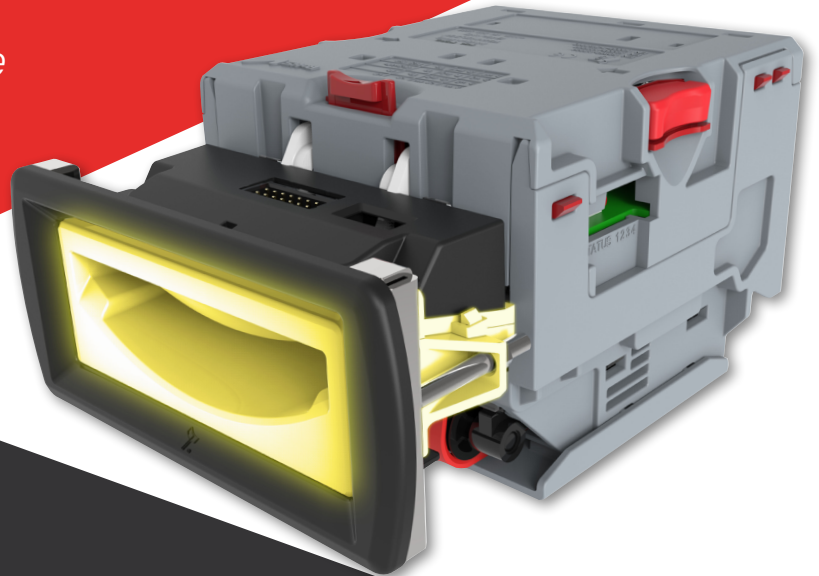

- Compact stackerless design
- Enhanced sensing technology
- Proven field reliability
- Future proof
- One build standard for global applications



FEATURES

- Compact, stackerless note validator
- Proven field reliability
- Over 100 different world currencies accepted
- Industry standard protocols
- Easy maintenance, free firmware updates



BENEFITS

- Suitable for most applications
- Lowest cost of ownership
- A truly global product
- Simple integration
- Future proof - quick & easy updates via USB, PC or handheld programmer



**Product
&
Service**

Technical Specification

Power

Requirements: 12V
Standby: 0.2A
Running: 1A
Peak: 1.5A

Interfaces

USB option
Open collector

Protocols

SSP*
ccTalk*
MDB*
Pulse
Parallel
Binary
Serial*

Bezel Options

66/82 mm width
Extended
Rainbow illumination options*

* Rainbow illumination bezel compatible with serial protocols only

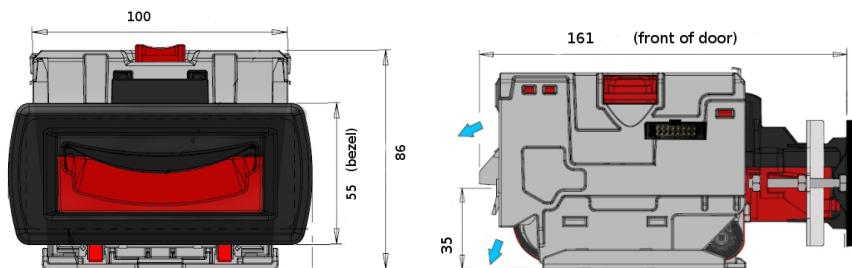

- Weight: 0.55kg

VIEW MORE
NOTE HANDLING
PRODUCTS >>

PRODUCT & SERVICE srl

Via IV Novembre, 54
20019- SETTIMO MILANESE (MI)
TEL. +39 0233497446
info@product.it
www.vendingproduct.com



Product
&
Service



Innovative Technology

INTELLIGENCE IN VALIDATION

NV11+

“Riciclatore di banconote”

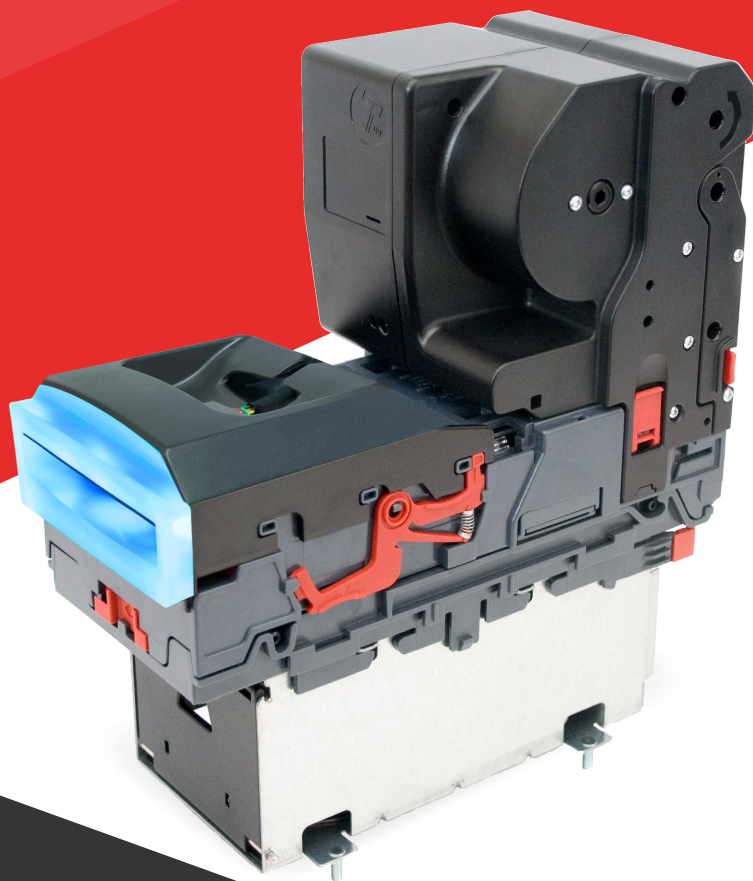

- Riciclatore di banconote compatto
- Comprovata affidabilità sul campo
- Garantisce significanti riduzioni di costi di interventi
- Ottimizza l'efficienza operativa



CARATTERISTICHE

- Riciclatore di 30 banconote di una denominazione
- Comprovata affidabilità in diversi mercati Europei
- Significativa riduzione dei livelli di fondo cassa
- Facile mantenimento, aggiornamenti firmware gratuiti
- le banconote presenti nel riciclatore possono essere trasferite nel cashbox



BENEFICI

- Ottimizza l'efficienza di cassa e riduce la mancanza di denaro
- Riduce l'investimento di denaro all'interno delle macchine
- Riduce il livello di denaro necessario all'operatività della macchina
- Aggiornamenti gratuiti tramite USB, flash card, PC o palmare
- Riduce i costi di interventi dell'operatore



**Product
&
Service**

Specifiche Tecniche

Alimentazione

Alimentazione: 12V
Assorbimento
A riposo: 350mA
In accettazione: 3A
Picco: 3.5A

Protocolli

SSP
ccTalk
MDB

Interfacce

USB
Open collector

Dimensioni banconote accettate

Larghezza: 60 - 82mm
Lunghezza: 115 - 150mm

Capacità del riciclatore

30 banconote

Frontalini disponibili

Standard da 82mm
Orizzontale da 82mm
Illuminato di tutti i colori

Cashbox disponibili

300 pz.
300 pz. con serratura
300 o 600 pz. estraibili

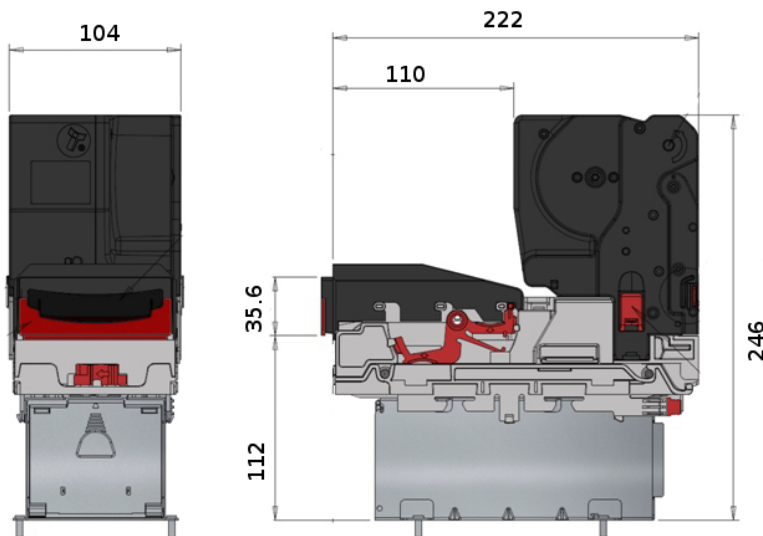

- Peso: 2.2kg

**GUARDA GLI ALTRI
PRODOTTI DI GESTIONE DEL
DENARO CONTANTE >>**

PRODUCT & SERVICE srl

Via IV Novembre, 54

20019- SETTIMO MILANESE (MI)

TEL. +39 0233497446

info@product.it

www.vendingproduct.com



**Product
&
Service**



®

Innovative Technology

INTELLIGENCE IN VALIDATION

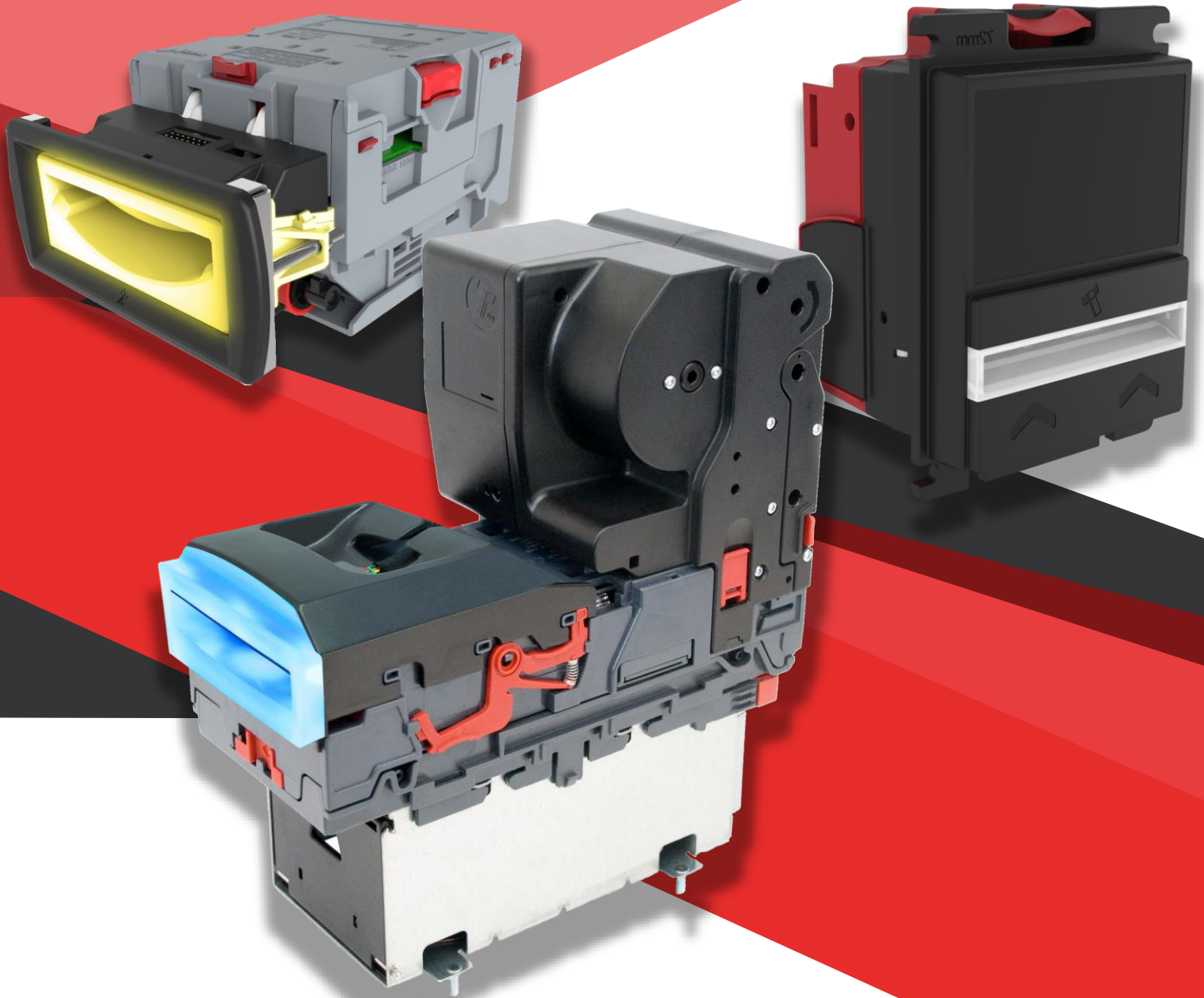

PRODUCT & SERVICE srl

Via IV Novembre, 54

20019- SETTIMO MILANESE (MI)

TEL. +39 0233497446

info@product.it

www.vendingproduct.com



**Product
&
Service**