

# UNIT INFORMATION

**LCM SERIES**  
13 to 25 ton  
45.7 to 88 kW

## Service Literature

100025  
Revised 08/2021

### LCM156U through 300U

The LCM156U, 180, 210, 240 and 300 units are configured to order units (CTO) with a wide selection of factory installed options.

Cooling capacities range from 13 to 25 tons (45.7 to 88 kW).

LCM156 and 180 utilize three compressors and four condenser fans, while LCM210, 240 and 300 utilize four compressors and six condenser fans.

Optional electric heat is factory- or field-installed. Electric heat operates in single or multiple stages depending on the kW input size. 15kW to 60 kW heat sections are available for the LCM156 and 180 units and 15 kW to 90 kW heat sections are available for the LCM210, 240, 300.

Multi-Stage Air Volume MSAV® blower option is available. The VFD-driven blower will operate at lower speeds when demand is low and increase to higher speeds when demand is high.

Variable speed VAV system is available as an option which enables supply duct static measurement to control blower CFM and discharge air temperature to control cooling stages.

All LCM units are designed to accept any of several different energy management thermostat control systems with minimum field wiring. Factory- or field-provided control options connect to the unit through Smartwire connectors. When “plugged in” the controls become an integral part of the unit wiring.

The CORE Control System is designed to accelerate equipment install and service. Standard with all Model L™ rooftop units, control system integrates key technologies that lower installation costs, drive system efficiency, and protect your investments.

The CORE Unit Controller is a microprocessor-based controller that provides flexible control of all unit functions.

Information contained in this manual is intended for use by qualified service technicians only. All specifications are subject to change. Procedures outlined in this manual are presented as a recommendation only and do not supersede or replace local or state codes.

If the unit must be lifted for service, rig unit by attaching four cables to the holes located in the unit base rail (two holes at each corner). Refer to the installation instructions for the proper rigging technique.



#### **⚠ WARNING**

Improper installation, adjustment, alteration, service or maintenance can cause property damage, personal injury or loss of life. Installation and service must be performed by a licensed professional HVAC installer or equivalent, service agency, or the gas supplier.

#### **⚠ WARNING**



Electric shock hazard. Can cause injury or death. Before attempting to perform any service or maintenance, turn the electrical power to unit OFF at disconnect switch(es). Unit may have multiple power supplies.

#### Table of Contents

Options / Accessories . . . . .	Page 2
Specifications . . . . .	Page 6
Blower Data . . . . .	Page 9
Electrical / Electric Heat Data . . . . .	Page 12
Electric Heat Capacities . . . . .	Page 17
Unit Parts Arrangement . . . . .	Page 18
I-Unit Components . . . . .	Page 18
II-Charging . . . . .	Page 33
III-Start Up - Operation . . . . .	Page 35
IV-System Service Checks . . . . .	Page 35
V-Maintenance . . . . .	Page 35
VI-Accessories . . . . .	Page 36
VII-Hot Gas Re-Heat . . . . .	Page 40
VIII-Staged Blower . . . . .	Page 44
IX- VAV System . . . . .	Page 46
X-Wiring and Operation Sequence . . . . .	Page 48

## OPTIONS / ACCESSORIES

Item Description	Catalog Number	Unit Model No					
		156	180	210	240	300	
<b>COOLING SYSTEM</b>							
Condensate Drain Trap	PVC	<b>22H54</b>	OX	OX	OX	OX	OX
	Copper	<b>76W27</b>	X	X	X	X	X
Corrosion Protection	Factory		O	O	O	O	O
Drain Pan Overflow Switch		<b>21Z07</b>	OX	OX	OX	OX	OX
Refrigerant Type		R-410A	O	O	O	O	O
Service Valves (not for Humiditrol™+ equipped units)		Factory	O	O	O	O	O
<b>BLOWER - SUPPLY AIR</b>							
<b>Blower Option</b>							
	SZVAV (Single Zone Variable Air Volume) - With VFD Bypass Control	Factory	O	O	O	O	O
	SZVAV (Single Zone Variable Air Volume) - Without VFD Bypass Control	Factory	O	O	O	O	O
	VAV (Variable Air Volume) - Without VFD Bypass Control	Factory	O	O	O	O	O
Motors	Belt Drive (standard efficiency) - 2 hp	Factory	O				
	Belt Drive (standard efficiency) - 3 hp	Factory	O	O	O		
	Belt Drive (standard efficiency) - 5 hp	Factory	O	O	O	O	O
	Belt Drive (standard efficiency) - 7.5 hp	Factory		O	O	O	O
	Belt Drive (standard efficiency) - 10 hp	Factory				O	O
Drive Kits See Blower Data Tables for usage and selection	Kit #1 535-725 rpm	Factory	O	O	O		
	Kit #2 710-965 rpm	Factory	O	O	O		
	Kit #3 685-856 rpm	Factory	O	O	O	O	O
	Kit #4 850-1045 rpm	Factory	O	O	O	O	O
	Kit #5 945-1185 rpm	Factory	O	O	O	O	O
	Kit #6 850-1045 rpm	Factory		O	O	O	O
	Kit #7 945-1185 rpm	Factory		O	O	O	O
	Kit #8 1045-1285 rpm	Factory		O	O	O	O
	Kit #10 1045-1285 rpm	Factory				O	O
	Kit #11 1135-1365 rpm	Factory				O	O
		Blower Belt Auto-Tensioner	Factory	O	O	O	O
<b>CABINET</b>							
Combination Coil/Hail Guards		<b>23U71</b>	X	X	X	X	X
<b>CONTROLS</b>							
Blower Proving Switch		<b>21Z10</b>	OX	OX	OX	OX	OX
Commercial Controls	LonTalk® Module - For Lennox® CORE Control System	<b>54W27</b>	OX	OX	OX	OX	OX
	Novar® LSE	Factory	O	O	O	O	O
	L Connection® Building Automation System	- - -	X	X	X	X	X
Dirty Filter Switch		<b>53W68</b>	OX	OX	OX	OX	OX
Fresh Air Tempering		<b>21Z08</b>	OX	OX	OX	OX	OX
Smoke Detector - Supply or Return (Power board and one sensor)		<b>83W40</b>	OX	OX	OX	OX	OX
Smoke Detector - Supply and Return (Power board and two sensors)		<b>83W41</b>	OX	OX	OX	OX	OX

NOTE - Catalog numbers shown are for ordering optional accessories if a field installed option is available.

OX = Configure To Order (Factory Installed) or Field Installed

O = Configure To Order (Factory Installed)

X = Field Installed

## OPTIONS / ACCESSORIES

Item Description	Catalog Number	Unit Model No					
		156	180	210	240	300	
<b>INDOOR AIR QUALITY</b>							
<b>Air Filters</b>							
Healthy Climate® High Efficiency Air Filters 24 x 24 x 2 in.	MERV 8 (Order 6)	<b>54W67</b>	OX	OX	OX	OX	OX
	MERV 13 (Order 6)	<b>52W40</b>	OX	OX	OX	OX	OX
	MERV 16 (Order 6)	<b>21U42</b>	OX	OX	OX	OX	OX
Replacement Media Filter With Metal Mesh Frame 24 x 24 x 2 in. (includes non-pleated filter media)	(Order 6)	<b>44N61</b>	X	X	X	X	X
<b>Indoor Air Quality (CO<sub>2</sub>) Sensors</b>							
Sensor - Wall-mount, off-white plastic cover with LCD display		<b>77N39</b>	X	X	X	X	X
Sensor - Wall-mount, off-white plastic cover, no display		<b>87N53</b>	X	X	X	X	X
Sensor - Black plastic case with LCD display, rated for plenum mounting		<b>87N52</b>	X	X	X	X	X
Sensor - Wall-mount, black plastic case, no display, rated for plenum mounting		<b>87N54</b>	X	X	X	X	X
CO <sub>2</sub> Sensor Duct Mounting Kit - for downflow applications		<b>85L43</b>	X	X	X	X	X
Aspiration Box - for duct mounting non-plenum rated CO <sub>2</sub> sensors ( <b>87N53</b> or <b>77N39</b> )		<b>90N43</b>	X	X	X	X	X
<b>Needlepoint Bipolar Ionization (NPBI)</b>							
Needlepoint Bipolar Ionization (NPBI) Kit		<b>21U37</b>	OX	OX	OX		
		<b>21U38</b>				OX	
		<b>21U39</b>					OX
<b>UVC Germicidal Light Kit</b>							
<sup>1</sup> Healthy Climate® UVC Light Kit (110/230V-1Ph)		<b>21A94</b>	OX	OX	OX	OX	OX
Step-Down Transformer	460V primary, 230V secondary	<b>10H20</b>	X	X	X	X	X
	575V primary, 230V secondary	<b>10H21</b>	X	X	X	X	X
<b>ELECTRICAL</b>							
Voltage 60 Hz	208/230V - 3 phase	Factory	O	O	O	O	O
	460V - 3 phase	Factory	O	O	O	O	O
	575V - 3 phase	Factory	O	O	O	O	O
HACR Circuit Breakers		Factory	O	O	O	O	O
Disconnect Switch (see Electric Heat Tables for usage)	80 amp	<b>54W85</b>	OX	OX	OX	OX	OX
	150 amp	<b>54W86</b>	OX	OX	OX	OX	OX
	250 amp	<b>54W87</b>	OX	OX	OX	OX	OX
<sup>2</sup> Short-Circuit Current Rating (SCCR) of 100kA (includes Phase/Voltage Detection)		Factory	O	O	O	O	O
GFI Service Outlets	15 amp non-powered, field-wired (208/230V, 460V, 575V)	<b>74M70</b>	OX	OX	OX	OX	OX
	15 amp factory-wired and powered (208/230V, 460V, 575V)	Factory	O	O	O	O	O
	20 amp non-powered, field-wired (575V only)	<b>67E01</b>	OX	OX	OX	OX	OX
Weatherproof Cover for GFI		<b>10C89</b>	X	X	X	X	X

<sup>1</sup> Lamps operate on 110-230V single-phase power supply. Step-down transformer may be ordered separately for 460V and 575V units. Alternately, 110V power supply may be used to directly power the UVC ballast(s).

<sup>2</sup> Disconnect Switch not available with higher SCCR option. Short-Circuit Current Rating option not available on field installed electric heat or 90kW electric heat (208/240V) models.

NOTE - Catalog numbers shown are for ordering optional accessories if a field installed option is available.

OX = Configure To Order (Factory Installed) or Field Installed

O = Configure To Order (Factory Installed)

X = Field Installed

## OPTIONS / ACCESSORIES

Item Description	Catalog Number	Unit Model No					
		156	180	210	240	300	
<b>ELECTRIC HEAT</b>							
15 kW	208/230V-3ph	<b>22H66</b>	OX	OX	OX	OX	OX
	460V-3ph	<b>22H67</b>	OX	OX	OX	OX	OX
	575V-3ph	<b>22V35</b>	OX	OX	OX	OX	OX
30 kW	208/230V-3ph	<b>22H68</b>	OX				
	460V-3ph	<b>22H69</b>	OX				
	575V-3ph	<b>22V36</b>	OX				
	208/230V-3ph	<b>22H70</b>		OX	OX	OX	OX
	460V-3ph	<b>22H71</b>		OX	OX	OX	OX
	575V-3ph	<b>22V37</b>		OX	OX	OX	OX
45 kW	208/230V-3ph	<b>22H72</b>	OX				
	460V-3ph	<b>22H73</b>	OX				
	575V-3ph	<b>22V38</b>	OX				
	208/230V-3ph	<b>22H74</b>		OX	OX	OX	OX
	460V-3ph	<b>22H75</b>		OX	OX	OX	OX
	575V-3ph	<b>22V39</b>		OX	OX	OX	OX
60 kW	208/230V-3ph	<b>22H76</b>	OX				
	460V-3ph	<b>22H77</b>	OX				
	575V-3ph	<b>22V40</b>	OX				
	208/230V-3ph	<b>22H78</b>		OX	OX	OX	OX
	460V-3ph	<b>22H79</b>		OX	OX	OX	OX
	575V-3ph	<b>22V41</b>		OX	OX	OX	OX
90 kW	208/230V-3ph	<b>22H80</b>			OX	OX	OX
	460V-3ph	<b>22H81</b>			OX	OX	OX
	575V-3ph	<b>22V42</b>			OX	OX	OX
<b>ECONOMIZER</b>							
<b>High Performance Economizer (Approved for California Title 24 Building Standards / AMCA Class 1A Certified)</b>							
High Performance Economizer	<b>22J18</b>	OX	OX	OX	OX	OX	
Downflow or Horizontal - Includes Outdoor Air Hood.							
NOTE - Order Downflow or Horizontal Barometric Relief Dampers separately.							
<b>Economizer Controls</b>							
Differential Enthalpy (Not for Title 24)	Order 2	<b>21Z09</b>	OX	OX	OX	OX	OX
Sensible Control	Sensor is Furnished	Factory	O	O	O	O	O
Single Enthalpy (Not for Title 24)		<b>21Z09</b>	OX	OX	OX	OX	OX
Global Control	Sensor Field Provided	Factory	O	O	O	O	O
Building Pressure Control		<b>13J77</b>	X	X	X	X	X
Outdoor Air CFM Control		<b>13J76</b>	X	X	X	X	X
<b>Barometric Relief Dampers With Exhaust Hood (required with economizer)</b>							
Downflow Barometric Relief Dampers		<b>54W78</b>	OX	OX	OX	OX	OX
Horizontal Barometric Relief Dampers		<b>16K99</b>	X	X	X	X	X
<b>OUTDOOR AIR</b>							
<b>Outdoor Air Dampers With Outdoor Air Hood</b>							
Motorized		<b>22J27</b>	OX	OX	OX	OX	OX
Manual		<b>13U05</b>	OX	OX	OX	OX	OX
<b><sup>1</sup> POWER EXHAUST (DOWNFLOW APPLICATIONS ONLY)</b>							
Standard Static, SCCR Rated	208/230V	<b>22H90</b>	OX	OX	OX	OX	OX
	460V	<b>22H91</b>	OX	OX	OX	OX	OX
	575V	<b>22V34</b>	OX	OX	OX	OX	OX
<b>HUMIDITROL™+ HOT GAS REHEAT OPTION - SZVAV MODELS ONLY</b>							
Humiditrol™+ Dehumidification Option	Factory		O	O	O	O	O

<sup>1</sup> Field installed Power Exhaust requires Economizer with Outdoor Air Hood and Downflow Barometric Relief Dampers with Exhaust Hood. Must be ordered separately.

NOTE - Catalog numbers shown are for ordering optional accessories if a field installed option is available.

OX = Configure To Order (Factory Installed) or Field Installed

O = Configure To Order (Factory Installed)

X = Field Installed



## OPTIONS / ACCESSORIES

Item Description	Catalog Number	Unit Model No				
		156	180	210	240	300
<b>ROOF CURBS</b>						
<b>Hybrid Roof Curbs, Downflow</b>						
8 in. height curb	11F58	X	X	X	X	X
14 in. height curb	11F59	X	X	X	X	X
18 in. height curb	11F60	X	X	X	X	X
24 in. height curb	11F61	X	X	X	X	X
<b>Adjustable Pitch Curb</b>						
14 in. height curb	43W26	X	X	X	X	X
<b>Standard Roof Curbs, Horizontal - Requires Horizontal Return Air Panel Kit</b>						
26 in. height - slab applications	11T89	X	X	X	X	
30 in. height - slab applications	11T90					X
37 in. height - rooftop applications	11T96	X	X	X	X	
41 in. height - rooftop applications	11T97					X
<b>Insulation Kit For Standard Horizontal Roof Curbs</b>						
for 26 in. height curb	73K32	X	X	X	X	
for 30 in. height curb	73K33					X
for 37 in. height curb	73K34	X	X	X	X	
for 41 in. height curb	73K35					X
<b>Horizontal Return Air Panel Kit</b>						
Required for Horizontal Applications with Roof Curb	87M00	X	X	X	X	X
<b>CEILING DIFFUSERS</b>						
Step-Down - Order one	RTD11-185S	13K63	X	X		
	RTD11-275S	13K64			X	X
Flush - Order one	FD11-185S	13K58	X	X		
	FD11-275S	13K59			X	X
Transitions (Supply and Return) - Order one	C1DIFF33C-1	12X68	X	X		
	C1DIFF34C-1	12X70			X	X

NOTE - Catalog numbers shown are for ordering optional accessories if a field installed option is available.

OX = Configure To Order (Factory Installed) or Field Installed

O = Configure To Order (Factory Installed)

X = Field Installed

**SPECIFICATIONS**

**13 TON**

<b>General Data</b>		<b>Nominal Tonnage</b>	<b>13 Ton</b>	<b>13 Ton</b>	
		<b>Model Number</b>	<b>LCM156U4M</b>	<b>LCM156U4V</b>	
		<b>Efficiency Type</b>	<b>Ultra-High</b>	<b>Ultra-High</b>	
		<b>Blower Type</b>	SZVAV (Single Zone Variable Air Volume)	VAV (Variable Air Volume)	
<b>Cooling Performance</b>	Gross Cooling Capacity - Btuh		154,000	154,000	
	<sup>1</sup> Net Cooling Capacity - Btuh		150,000	150,000	
	<sup>1</sup> AHRI Rated Air Flow - cfm		4250	4250	
	Total Unit Power - kW		12.3	12.3	
	<sup>1</sup> IEER (Btuh/Watt)		19.0	18.5	
	<sup>1</sup> EER (Btuh/Watt)		12.2	12.2	
<b>Refrigerant Charge</b>		<b>Refrigerant Type</b>	R-410A	R-410A	
	Without Reheat	Circuit 1	16 lbs. 12 oz.	16 lbs. 12 oz.	
		Circuit 2	9 lbs. 9 oz.	9 lbs. 9 oz.	
		Circuit 3	9 lbs. 8 oz.	9 lbs. 8 oz.	
	With Reheat	Circuit 1	21 lbs. 3 oz.	- - -	
		Circuit 2	12 lbs. 8 oz.	- - -	
		Circuit 3	9 lbs. 8 oz.	- - -	
<b>Electric Heating Options Available</b>		15-30-45-60 kW			
<b>Compressor Type (number)</b>		Variable Capacity Scroll (1) Fixed Capacity Scroll (2)			
<b>Outdoor Coils</b>	Net face area (total) - sq. ft.		55.2	55.2	
	Tube diameter - in.		3/8	3/8	
	Number of rows		2	2	
	Fins per inch		20	20	
<b>Outdoor Coil Fans</b>	Motor - (No.) horsepower		(4) 1/3 ECM	(4) 1/3 ECM	
	Motor rpm		450-1075	450-1075	
	Total Motor watts		155 - 1150	155 - 1150	
	Diameter - (No.) in.		(4) 24	(4) 24	
	Number of blades		3	3	
	Total Air volume - cfm		16,000	16,000	
<b>Indoor Coils</b>	Net face area (total) - sq. ft.		21.40	21.40	
	Tube diameter - in.		3/8	3/8	
	Number of rows		3	3	
	Fins per inch		14	14	
	Drain connection - No. and size		(1) 1 in. FPT	(1) 1 in. FPT	
	Expansion device type	Balance port TXV, removable head			
<sup>2</sup> <b>Indoor Blower and Drive Selection</b>	Nominal motor output	2 hp, 3 hp, 5 hp			
	Max. usable motor output (US)	2.3 hp, 3.45 hp, 5.75 hp			
	Motor - Drive kit number	<b>2 hp</b>			
		<b>Kit 1</b> 535-725 rpm			
<b>Kit 2</b> 710-965 rpm					
<b>3 hp</b>					
<b>Kit 1</b> 535-725 rpm					
<b>Kit 2</b> 710-965 rpm					
<b>5 hp</b>					
<b>Kit 3</b> - 685-856 rpm					
<b>Kit 4</b> 850-1045 rpm					
<b>Kit 5</b> 945-1185 rpm					
	Blower wheel nominal D x W - in.		(2) 15 x 15 in.	(2) 15 x 15 in.	
<b>Filters</b>	Type of filter	Fiberglass, disposable			
	Number and size - in.	(6) 24 x 24 x 2			
<b>Electrical characteristics</b>		208/230V, 460V, or 575V - 60 hz -3 phase			

NOTE - Net capacity includes evaporator blower motor heat deduction. Gross capacity does not include evaporator blower motor heat deduction.  
<sup>1</sup> AHRI Certified to AHRI Standard 340/360; 95°F outdoor air temperature and 80°F db/67°F wb entering evaporator air; minimum external duct static pressure.  
<sup>2</sup> Using total air volume and system static pressure requirements determine from blower performance tables rpm and motor output required. Maximum usable output of motors furnished are shown. In Canada, nominal motor output is also maximum usable motor output. If motors of comparable output are used, be sure to keep within the service factor limitations outlined on the motor nameplate.  
 NOTE – Blower motor service factor = 1.0.

**SPECIFICATIONS**

**15 TON | 17.5 TON**

General Data		Nominal Tonnage	15 Ton	15 Ton	17.5 Ton	17.5 Ton	
		Model Number	LCM180U4M	LCM180U4V	LCM210U4M	LCM210U4V	
		Efficiency Type	Ultra-High	Ultra-High	Ultra-High	Ultra-High	
		Blower Type	SZVAV (Single Zone Variable Air Volume)	VAV (Variable Air Volume)	SZVAV (Single Zone Variable Air Volume)	VAV (Variable Air Volume)	
<b>Cooling Performance</b>	Gross Cooling Capacity - Btuh		176,000	176,000	206,000	206,000	
	<sup>1</sup> Net Cooling Capacity - Btuh		172,000	172,000	200,000	200,000	
	<sup>1</sup> AHRI Rated Air Flow - cfm		5250	5250	5400	5400	
	Total Unit Power - kW		14.3	14.3	16.4	16.4	
	<sup>1</sup> IEER (Btuh/Watt)		19.0	17.5	18.8	18.0	
	<sup>1</sup> EER (Btuh/Watt)		12.0	12.0	12.2	12.2	
<b>Refrigerant Charge</b>	Refrigerant Type		R-410A	R-410A	R-410A	R-410A	
	Without Reheat	Circuit 1	19 lbs. 14 oz.	19 lbs. 14 oz.	10 lbs. 8 oz.	10 lbs. 8 oz.	
		Circuit 2	10 lbs. 15 oz.	10 lbs. 15 oz.	9 lbs. 10 oz.	9 lbs. 10 oz.	
		Circuit 3	10 lbs. 6 oz.	10 lbs. 6 oz.	9 lbs. 10 oz.	9 lbs. 10 oz.	
		Circuit 4	---	---	9 lbs. 12 oz.	9 lbs. 12 oz.	
	With Reheat	Circuit 1	22 lbs. 2 oz.	---	10 lbs. 8 oz.	---	
		Circuit 2	12 lbs. 6 oz.	---	11 lbs. 0 oz.	---	
		Circuit 3	10 lbs. 6 oz.	---	9 lbs. 10 oz.	---	
		Circuit 4	---	---	9 lbs. 12 oz.	---	
	<b>Electric Heating Options Available</b>			15-30-45-60 kW		15-30-45-60-90 kW	
<b>Compressor Type (number)</b>			Variable Capacity Scroll (1) Fixed Capacity Scroll (2)		Variable Capacity Scroll (1) Fixed Capacity Scroll (3)		
<b>Outdoor Coils (Fin/Tube)</b>	Net face area (total) - sq. ft.		55.2	55.2	55.2	55.2	
	Tube diameter - in.		3/8	3/8	3/8	3/8	
	Number of rows		2	2	2	2	
	Fins per inch		20	20	20	20	
<b>Outdoor Coil Fans</b>	Motor - (No.) horsepower		(4) 1/3 ECM	(4) 1/3 ECM	(6) 1/3 ECM	(6) 1/3 ECM	
	Motor rpm		280-1075	280-1075	640-950	640-950	
	Total Motor watts		150 -1350	150 -1350	290 -1250	290 -1250	
	Diameter - (No.) in.		(4) 24	(4) 24	(6) 24	(6) 24	
	Number of blades		3	3	3	3	
	Total Air volume - cfm		16,000	16,000	18,600	18,600	
	Expansion device type		Balance port TXV, removable head				
<b>Indoor Coils</b>	Net face area (total) - sq. ft.		21.40	21.40	21.40	21.40	
	Tube diameter - in.		3/8	3/8	3/8	3/8	
	Number of rows		3	3	3	3	
	Fins per inch		14	14	14	14	
	Drain connection - No. and size		(1) 1 in. FPT	(1) 1 in. FPT	(1) 1 in. FPT	(1) 1 in. FPT	
	Expansion device type		Balance port TXV, removable head				
<b><sup>2</sup> Indoor Blower and Drive Selection</b>	Nominal motor output		3 hp, 5 hp, 7.5 hp				
	Max. usable motor output (US)		3.45 hp, 5.75 hp, 8.62 hp				
	Motor - Drive kit number		<b>3 hp</b> Kit 1 535-725 rpm Kit 2 710-965 rpm <b>5 hp</b> Kit 3 685-856 rpm Kit 4 850-1045 rpm Kit 5 945-1185 rpm <b>7.5 hp</b> Kit 6 850-1045 rpm Kit 7 945-1185 rpm Kit 8 1045-1285 rpm				
	Blower wheel nominal D x W - in.		(2) 15 x 15				
	<b>Filters</b>	Type of filter		Fiberglass, disposable			
		Number and size - in.		(6) 24 x 24 x 2			
	<b>Electrical characteristics</b>			208/230V, 460V, or 575V - 60 hz -3 phase			

NOTE - Net capacity includes evaporator blower motor heat deduction. Gross capacity does not include evaporator blower motor heat deduction.  
<sup>1</sup> AHRI Certified to AHRI Standard 340/360; 95°F outdoor air temperature and 80°F db/67°F wb entering evaporator air; minimum external duct static pressure.  
<sup>2</sup> Using total air volume and system static pressure requirements determine from blower performance tables rpm and motor output required. Maximum usable output of motors furnished are shown. In Canada, nominal motor output is also maximum usable motor output. If motors of comparable output are used, be sure to keep within the service factor limitations outlined on the motor nameplate.  
 NOTE – Blower motor service factor = 1.0.

**SPECIFICATIONS**

**20 TON | 25 TON**

General Data		Nominal Tonnage	20 Ton	20 Ton	25 Ton	25 Ton
Model Number			LCM240U4M	LCM240U4V	LCM300U4M	LCM300U4V
Efficiency Type			Ultra-High	Ultra-High	Ultra-High	Ultra-High
Blower Type			SZVAV (Single Zone Variable Air Volume)	VAV (Variable Air Volume)	SZVAV (Single Zone Variable Air Volume)	VAV (Variable Air Volume)
<b>Cooling Performance</b>	Gross Cooling Capacity - Btuh		235,000	235,000	277,000	277,000
	<sup>1</sup> Net Cooling Capacity - Btuh		228,000	228,000	270,000	270,000
	<sup>1</sup> AHRI Rated Air Flow - cfm		6000	6000	7400	7400
	Total Unit Power - kW		19.0	19.0	19.0	19.0
	<sup>1</sup> IEER (Btuh/Watt)		18.4	17.5	17.5	16.5
	<sup>1</sup> EER (Btuh/Watt)		12.0	12.0	10.6	10.6
<b>Refrigerant Charge</b>	Refrigerant Type		R-410A	R-410A	R-410A	R-410A
	Without Humiditrol™+	Circuit 1	12 lbs. 2 oz.	12 lbs. 2 oz.	12 lbs. 8 oz.	12 lbs. 8 oz.
		Circuit 2	12 lbs. 7 oz.	12 lbs. 7 oz.	11 lbs. 8 oz.	11 lbs. 8 oz.
		Circuit 3	12 lbs. 0 oz.	12 lbs. 0 oz.	14 lbs. 8 oz.	14 lbs. 8 oz.
		Circuit 4	12 lbs. 10 oz.	12 lbs. 10 oz.	11 lbs. 8 oz.	11 lbs. 8 oz.
	With Humiditrol™+	Circuit 1	13 lbs. 4 oz.	---	17 lbs. 2 oz.	---
		Circuit 2	13 lbs. 12 oz.	---	17 lbs. 5 oz.	---
		Circuit 3	12 lbs. 0 oz.	---	14 lbs. 8 oz.	---
		Circuit 4	12 lbs. 10 oz.	---	11 lbs. 8 oz.	---
	<b>Electric Heat Options Available</b>			15-30-45-60-90 kW		
<b>Compressor Type (number)</b>			Variable Capacity Scroll (1) Fixed Capacity Scroll (3)			
<b>Outdoor Coils (Fin/Tube)</b>	Net face area (total) - sq. ft.		55.2	55.2	55.2	55.2
	Tube diameter - in.		3/8	3/8	3/8	3/8
	Number of rows		2	2	3	3
	Fins per inch		20	20	20	20
<b>Outdoor Coil Fans</b>	Motor - (No.) horsepower		(6) 1/3 ECM	(6) 1/3 ECM	(6) 1/3 ECM	(6) 1/3 ECM
	Motor rpm		450 - 950	450 - 950	515 - 1000	515 - 1000
	Total Motor watts		130 -1530	130 -1530	180 - 1730	180 - 1730
	Diameter - (No.) in.		(6) 24	(6) 24	(6) 24	(6) 24
	Number of blades		3	3	3	3
	Total Air volume - cfm		18,000	18,000	18,300	18,300
<b>Indoor Coils</b>	Net face area (total) - sq. ft.		21.40	21.40	21.40	21.40
	Tube diameter - in.		3/8	3/8	3/8	3/8
	Number of rows		4	4	4	4
	Fins per inch		14	14	14	14
	Drain connection - No. and size		(1) 1 in. FPT	(1) 1 in. FPT	(1) 1 in. FPT	(1) 1 in. FPT
Expansion device type			Balance port TXV, removable head			
<sup>2</sup> <b>Indoor Blower and Drive Selection</b>	Nominal motor output		5 hp, 7.5 hp, 10 hp			
	Max. usable motor output (US)		5.75 hp, 8.62 hp, 11.5 hp			
	Motor - Drive kit number		<b>5 hp</b> Kit 3 685-856 rpm Kit 4 850-1045 rpm Kit 5 945-1185 rpm <b>7.5 hp</b> Kit 6 850-1045 rpm Kit 7 945-1185 rpm Kit 8 1045-1285 rpm <b>10 hp</b> Kit 7 945-1185 rpm Kit 10 1045-1285 rpm Kit 11 1135-1365 rpm			
	Blower wheel nominal D x W - in.		(2) 15 x 15			
<b>Filters</b>	Type of filter		Fiberglass, disposable			
	Number and size - in.		(6) 24 x 24 x 2			
<b>Electrical characteristics</b>			208/230V, 460V, or 575V - 60 Hz -3 phase			

NOTE - Net capacity includes evaporator blower motor heat deduction. Gross capacity does not include evaporator blower motor heat deduction.

<sup>1</sup> AHRI Certified to AHRI Standard 340/360; 95°F outdoor air temperature and 80°F db/67°F wb entering evaporator air; minimum external duct static pressure.

<sup>2</sup> Using total air volume and system static pressure requirements determine from blower performance tables rpm and motor output required. Maximum usable output of motors furnished are shown. In Canada, nominal motor output is also maximum usable motor output. If motors of comparable output are used, be sure to keep within the service factor limitations outlined on the motor nameplate.

NOTE - Blower motor service factor = 1.0.

**BLOWER TABLE INCLUDES RESISTANCE FOR BASE UNIT ONLY WITH DRY INDOOR COIL & AIR FILTERS IN PLACE**

**FOR ALL UNITS ADD:**

- 1 - Wet indoor coil air resistance of selected unit.
- 2 - Any factory installed options air resistance (electric heat, Economizer, etc.)
- 3 - Any field installed accessories air resistance (electric heat, duct resistance, diffuser, etc.)

Then determine from blower table blower motor output and drive required.

See page 10 for wet coil and option/accessory air resistance data.

See page 10 for factory installed drive kit specifications.

**MINIMUM AIR VOLUME REQUIRED FOR USE WITH OPTIONAL ELECTRIC HEAT**

LCM156H units require 5200 cfm minimum air with electric heat.

All other units require 6000 cfm minimum air with electric heat.

Air Volume cfm	TOTAL STATIC PRESSURE - Inches Water Gauge (Pa)																									
	0.20		0.40		0.60		0.80		1.00		1.20		1.40		1.60		1.80		2.00		2.20		2.40		2.60	
	RPM	BHP	RPM	BHP	RPM	BHP	RPM	BHP	RPM	BHP	RPM	BHP	RPM	BHP	RPM	BHP	RPM	BHP	RPM	BHP	RPM	BHP	RPM	BHP	RPM	BHP
2750	385	0.30	505	0.50	600	0.70	680	0.90	755	1.10	820	1.30	885	1.50	950	1.70	1015	1.90	1080	2.10	1145	2.30	1210	2.50	1275	2.70
3000	395	0.35	515	0.55	610	0.75	685	1.00	760	1.20	825	1.45	890	1.70	955	1.95	1020	2.20	1085	2.45	1150	2.70	1215	2.95	1280	3.20
3250	405	0.40	520	0.60	615	0.85	695	1.10	765	1.30	830	1.60	900	1.85	965	2.10	985	2.35	1050	2.60	1115	2.85	1180	3.10	1245	3.35
3500	415	0.45	530	0.70	620	0.95	700	1.20	775	1.45	840	1.70	900	2.00	965	2.25	1005	2.50	1070	2.75	1135	3.00	1200	3.25	1265	3.50
3750	425	0.50	540	0.75	630	1.05	710	1.30	780	1.60	845	1.85	905	2.15	960	2.40	1010	2.65	1075	2.90	1140	3.15	1205	3.40	1270	3.65
4000	435	0.55	545	0.85	635	1.10	715	1.40	785	1.70	850	2.00	910	2.30	965	2.55	1020	2.80	1085	3.05	1150	3.30	1215	3.55	1280	3.80
4250	445	0.60	555	0.90	645	1.25	725	1.55	795	1.85	855	2.15	915	2.45	970	2.70	1035	3.00	1100	3.25	1165	3.50	1230	3.75	1295	4.00
4500	455	0.70	565	1.00	655	1.35	730	1.65	800	2.00	865	2.35	925	2.65	980	2.90	1045	3.15	1110	3.40	1175	3.65	1240	3.90	1305	4.15
4750	470	0.75	575	1.10	660	1.45	740	1.80	810	2.15	870	2.50	930	2.85	985	3.10	1045	3.35	1110	3.60	1175	3.85	1240	4.10	1305	4.35
5000	480	0.85	585	1.25	670	1.60	750	1.95	815	2.30	880	2.70	940	3.05	995	3.30	1055	3.55	1120	3.80	1185	4.05	1250	4.30	1315	4.55
5250	495	0.95	595	1.35	680	1.70	755	2.10	825	2.50	890	2.90	945	3.25	1000	3.50	1060	3.75	1125	4.00	1190	4.25	1255	4.50	1320	4.75
5500	505	1.05	605	1.45	690	1.85	765	2.25	835	2.65	895	3.05	950	3.45	1010	3.80	1075	4.05	1140	4.30	1205	4.55	1270	4.80	1335	5.05
5750	520	1.15	615	1.60	700	2.00	775	2.45	840	2.85	905	3.25	960	3.65	1020	4.00	1085	4.25	1150	4.50	1215	4.75	1280	5.00	1345	5.25
6000	530	1.30	630	1.75	710	2.15	785	2.60	850	3.05	910	3.45	970	3.90	1030	4.30	1095	4.50	1160	4.75	1225	5.00	1290	5.25	1355	5.50
6250	545	1.40	640	1.90	720	2.35	795	2.80	860	3.25	920	3.70	975	4.15	1030	4.55	1095	4.75	1160	5.00	1225	5.25	1290	5.50	1355	5.75
6500	560	1.55	650	2.05	730	2.50	805	3.00	870	3.45	930	3.95	985	4.40	1040	4.85	1105	5.05	1170	5.30	1235	5.55	1300	5.80	1365	6.05
6750	570	1.70	665	2.20	745	2.70	815	3.20	880	3.70	940	4.20	995	4.65	1050	5.05	1115	5.25	1180	5.50	1245	5.75	1310	6.00	1375	6.30
7000	585	1.85	675	2.35	755	2.90	825	3.40	890	3.95	950	4.45	1005	4.90	1060	5.30	1125	5.50	1190	5.75	1255	6.00	1320	6.25	1385	6.50
7250	600	2.00	690	2.60	765	3.10	835	3.65	900	4.15	965	4.65	1015	5.05	1070	5.45	1135	5.65	1200	5.90	1265	6.15	1330	6.40	1395	6.65
7500	615	2.20	700	2.75	775	3.30	845	3.85	910	4.45	975	4.95	1025	5.40	1080	5.75	1145	5.95	1210	6.15	1275	6.40	1340	6.65	1405	6.90
7750	630	2.40	715	3.00	790	3.55	855	4.10	920	4.70	985	5.25	1035	5.75	1090	6.05	1155	6.25	1220	6.45	1285	6.70	1350	6.95	1415	7.15
8000	640	2.55	725	3.20	800	3.80	865	4.35	930	4.95	995	5.50	1045	6.00	1100	6.30	1165	6.50	1230	6.70	1295	6.95	1360	7.20	1425	7.40
8250	655	2.80	740	3.40	810	4.00	880	4.60	940	5.25	995	5.85	1050	6.35	1105	6.60	1170	6.80	1240	7.00	1305	7.20	1370	7.45	1435	7.65
8500	670	3.00	750	3.65	825	4.30	890	4.90	950	5.55	1005	6.15	1060	6.60	1115	6.85	1180	7.05	1250	7.25	1315	7.45	1380	7.70	1445	7.90
8750	685	3.25	765	3.90	835	4.55	900	5.20	960	5.85	1015	6.45	1070	7.00	1125	7.15	1190	7.35	1260	7.55	1325	7.75	1390	7.95	1455	8.10
9000	700	3.50	780	4.20	850	4.85	910	5.50	970	6.15	1025	6.80	1080	7.50	1135	7.65	1200	7.85	1270	8.05	1335	8.25	1400	8.45	1465	8.65
9250	715	3.75	790	4.45	860	5.15	925	5.85	985	6.55	1040	7.20	1095	7.85	1145	8.00	1210	8.20	1280	8.40	1345	8.60	1410	8.80	1475	9.00
9500	730	4.00	805	4.75	875	5.45	935	6.15	995	6.90	1050	7.60	1100	8.25	1150	8.40	1215	8.60	1285	8.80	1350	9.00	1415	9.20	1480	9.40
9750	745	4.30	820	5.05	885	5.75	950	6.55	1005	7.20	1060	7.95	1110	8.65	1160	8.80	1225	9.00	1295	9.20	1360	9.40	1425	9.60	1490	9.80
10,000	760	4.60	835	5.40	900	6.15	960	6.85	1015	7.60	1070	8.35	1120	9.05	1170	9.20	1235	9.40	1305	9.60	1370	9.80	1435	10.00	1500	10.20
10,250	775	4.90	845	5.65	910	6.45	970	7.20	1030	8.00	1080	8.75	1135	9.55	1180	9.70	1245	9.90	1315	10.10	1380	10.30	1445	10.50	1510	10.70
10,500	790	5.20	860	6.00	925	6.85	985	7.65	1040	8.40	1095	9.20	1145	10.00	1190	10.20	1255	10.40	1325	10.60	1390	10.80	1455	11.00	1520	11.20
10,750	805	5.55	875	6.40	940	7.25	1000	8.05	1055	8.85	1105	9.65	1155	10.45	1200	10.65	1265	10.85	1335	11.05	1400	11.25	1465	11.45	1530	11.60
11,000	820	5.90	890	6.80	950	7.60	1010	8.45	1065	9.30	1115	10.05	1165	10.90	1210	11.05	1275	11.25	1345	11.45	1410	11.65	1475	11.85	1540	12.00

## BLOWER DATA

### FACTORY INSTALLED BELT DRIVE KIT SPECIFICATIONS

Motor Efficiency	Nominal hp	Maximum hp	Drive Kit Number	RPM Range
Standard	2	2.30	1	535 - 725
Standard	2	2.30	2	710 - 965
Standard	3	3.45	1	535 - 725
Standard	3	3.45	2	710 - 965
Standard	5	5.75	3	685 - 856
Standard	5	5.75	4	850 - 1045
Standard	5	5.75	5	945 - 1185
Standard	7.5	8.63	6	850 - 1045
Standard	7.5	8.63	7	945 - 1185
Standard	7.5	8.63	8	1045 - 1285
Standard	10	11.50	7	945 - 1185
Standard	10	11.50	10	1045 - 1285
Standard	10	11.50	11	1135 - 1365

NOTE - Using total air volume and system static pressure requirements determine from blower performance tables rpm and motor output required. Maximum usable output of motors furnished are shown. In Canada, nominal motor output is also maximum usable motor output. If motors of comparable output are used, be sure to keep within the service factor limitations outlined on the motor nameplate.

NOTE - Blower motor service factor = 1.0.

### FACTORY INSTALLED OPTIONS/FIELD INSTALLED ACCESSORY AIR RESISTANCE

Air Volume cfm	Wet Indoor Coil		Humiditrol™+ Reheat Coil	Electric Heat	Economizer	Filters			Horizontal Roof Curb	
	156 180	210 240 300				156 thru 240	300			
	in. w.g.	in. w.g.						MERV 8	MERV 13	MERV 16
2750	.01	.02	.01	---	---	.01	.03	0.06	.03	-
3000	.01	.02	.01	---	---	.01	.03	0.06	.04	-
3250	.01	.03	.01	---	---	.01	.04	0.07	.04	.01
3500	.01	.03	.02	---	---	.01	.04	0.08	.05	.01
3750	.01	.03	.02	---	---	.01	.04	0.08	.05	.01
4000	.02	.04	.02	---	---	.01	.04	0.09	.06	.02
4250	.02	.04	.02	---	---	.01	.05	0.10	.07	.02
4500	.02	.05	.02	---	---	.01	.05	0.10	.07	.02
4750	.02	.05	.02	---	---	.02	.05	0.11	.08	.03
5000	.02	.05	.02	---	---	.02	.06	0.12	.08	.03
5250	.02	.06	.03	---	---	.02	.06	0.12	.09	.04
5500	.02	.07	.03	---	---	.02	.06	0.13	.10	.04
5750	.03	.07	.03	---	---	.02	.07	0.14	.11	.05
6000	.03	.08	.03	.01	---	.03	.07	0.14	.11	.06
6250	.03	.08	.03	.01	.01	.03	.07	0.15	.12	.07
6500	.03	.09	.04	.01	.02	.03	.08	0.16	.13	.08
6750	.04	.10	.04	.01	.03	.03	.08	0.17	.14	.08
7000	.04	.10	.04	.01	.04	.04	.08	0.17	.15	.09
7250	.04	.11	.04	.01	.05	.04	.09	0.18	.16	.10
7500	.05	.12	.05	.01	.06	.04	.09	0.19	.17	.11
8000	.05	.13	.05	.02	.09	.05	.10	0.21	.19	.13
8500	.06	.15	.05	.02	.11	.05	.10	0.22	.21	.15
9000	.07	.16	.06	.04	.14	.06	.11	0.24	.24	.17
9500	.08	.18	.07	.05	.16	.07	.12	0.25	.26	.19
10,000	.08	.20	.07	.06	.19	.07	.12	0.27	.29	.21
10,500	.09	.22	.08	.09	.22	.08	.13	0.29	.31	.24
11,000	.11	.24	.08	.11	.25	.09	.14	0.30	.34	.27



## BLOWER DATA

### POWER EXHAUST FAN PERFORMANCE

Return Air System Static Pressure	Air Volume Exhausted
in. w.g.	cfm
0.00	8630
0.05	8210
0.10	7725
0.15	7110
0.20	6470
0.25	5790
0.30	5060
0.35	4300
0.40	3510
0.45	2690
0.50	1840

### CEILING DIFFUSER AIR RESISTANCE - in. w.g.

Air Volume cfm	Step-Down Diffuser						Flush Diffuser	
	RTD11-185S			RTD11-275S			FD11-185S	FD11-275S
	2 Ends Open	1 Side/2 Ends Open	All Ends & Sides Open	2 Ends Open	1 Side/2 Ends Open	All Ends & Sides Open		
5000	.51	.44	.39	---	---	---	.27	---
5200	.56	.48	.42	---	---	---	.30	---
5400	.61	.52	.45	---	---	---	.33	---
5600	.66	.56	.48	---	---	---	.36	---
5800	.71	.59	.51	---	---	---	.39	---
6000	.76	.63	.55	.36	.31	.27	.42	.29
6200	.80	.68	.59	---	---	---	.46	---
6400	.86	.72	.63	---	---	---	.50	---
6500	---	---	---	.42	.36	.31	---	.34
6600	.92	.77	.67	---	---	---	.54	---
6800	.99	.83	.72	---	---	---	.58	---
7000	1.03	.87	.76	.49	.41	.36	.62	.40
7200	1.09	.92	.80	---	---	---	.66	---
7400	1.15	.97	.84	---	---	---	.70	---
7500	---	---	---	.51	.46	.41	---	.45
7600	1.20	1.02	.88	---	---	---	.74	---
8000	---	---	---	.59	.49	.43	---	.50
8500	---	---	---	.69	.58	.50	---	.57
9000	---	---	---	.79	.67	.58	---	.66
9500	---	---	---	.89	.75	.65	---	.74
10,000	---	---	---	1.00	.84	.73	---	.81
10,500	---	---	---	1.10	.92	.80	---	.89
11,000	---	---	---	1.21	1.01	.88	---	.96

### CEILING DIFFUSER AIR THROW DATA - ft.

Model No.	Air Volume cfm	<sup>1</sup> Effective Throw Range - ft.		Model No.	Air Volume cfm	<sup>1</sup> Effective Throw Range - ft.	
		RTD11-185S Step-Down	FD11-185S Flush			RTD11-275S Step-Down	FD11-275S Flush
156 180	5600	39 - 49	28 - 37	210 240 300	7200	33 - 38	26 - 35
	5800	42 - 51	29 - 38		7400	35 - 40	28 - 37
	6000	44 - 54	40 - 50		7600	36 - 41	29 - 38
	6200	45 - 55	42 - 51		7800	38 - 43	40 - 50
	6400	46 - 55	43 - 52		8000	39 - 44	42 - 51
	6600	47 - 56	45 - 56		8200	41 - 46	43 - 52
					8400	43 - 49	44 - 54
					8600	44 - 50	46 - 57
					8800	47 - 55	48 - 59

<sup>1</sup> Throw is the horizontal or vertical distance an airstream travels on leaving the outlet or diffuser before the maximum velocity is reduced to 50 ft. per minute. Four sides open.

**ELECTRICAL/ELECTRIC HEAT DATA**

**13 TON**

Model No.		LCM156U4								
<sup>1</sup> Voltage - 60Hz		208/230V-3ph			460V-3ph			575V-3ph		
Compressor 1	Rated Load Amps	13.3			5.9			4.7		
	Locked Rotor Amps	21			11			12		
Compressor 2	Rated Load Amps	14.5			6.3			6		
	Locked Rotor Amps	98			55			41		
Compressor 3	Rated Load Amps	14.5			6.3			6		
	Locked Rotor Amps	98			55			41		
Outdoor Fan Motors (4)	Full Load Amps (total)	2.8 (11.2)			1.4 (5.6)			1.1 (4.4)		
Power Exhaust (2) 0.33 HP	Full Load Amps (total)	2.4 (4.8)			1.3 (2.6)			1 (2)		
Service Outlet 115V GFI (amps)		15			15			20		
Indoor Blower Motor	Horsepower	2	3	5	2	3	5	2	3	5
	Full Load Amps	7.5	10.6	16.7	3.4	4.8	7.6	2.7	3.9	6.1
<sup>2</sup> Maximum Overcurrent Protection (MOCP)	Unit Only	70	80	90	35	35	40	30	30	30
	With (2) 0.33 HP Power Exhaust	80	80	90	35	35	40	30	30	35
<sup>3</sup> Minimum Circuit Ampacity (MCA)	Unit Only	65	68	75	30	31	34	26	27	29
	With (2) 0.33 HP Power Exhaust	70	73	80	32	34	37	28	29	31

**ELECTRIC HEAT DATA**

		Electric Heat Voltage	208V	240V	208V	240V	208V	240V	480V	480V	480V	600V	600V	600V
<sup>2</sup> Maximum Overcurrent Protection (MOCP)	Unit+ Electric Heat	15 kW	70	70	80	80	90	90	35	35	40	30	30	30
		30 kW	<sup>4</sup> 90	100	<sup>4</sup> 100	110	<sup>4</sup> 100	125	50	60	60	40	45	45
		45 kW	150	150	150	150	<sup>4</sup> 150	175	80	80	80	60	60	70
		60 kW	<sup>4</sup> 150	175	<sup>4</sup> 150	175	<sup>4</sup> 150	175	80	80	90	70	70	70
<sup>3</sup> Minimum Circuit Ampacity (MCA)	Unit+ Electric Heat	15 kW	65	65	68	68	75	75	30	31	34	26	27	29
		30 kW	88	100	92	104	100	112	50	52	55	40	41	44
		45 kW	127	145	131	149	139	157	72	74	78	58	60	62
		60 kW	135	154	139	158	146	166	77	79	82	62	63	66
<sup>2</sup> Maximum Overcurrent Protection (MOCP)	Unit+ Electric Heat and (2) 0.33 HP Power Exhaust	15 kW	80	80	80	80	90	90	35	35	40	30	30	35
		30 kW	<sup>4</sup> 100	110	<sup>4</sup> 100	110	<sup>4</sup> 110	125	60	60	60	45	45	50
		45 kW	<sup>4</sup> 150	175	<sup>4</sup> 150	175	<sup>4</sup> 150	175	80	80	90	70	70	70
		60 kW	<sup>4</sup> 150	175	<sup>4</sup> 150	175	175	175	80	90	90	70	70	70
<sup>3</sup> Minimum Circuit Ampacity (MCA)	Unit+ Electric Heat and (2) 0.33 HP Power Exhaust	15 kW	70	70	73	73	80	80	32	34	37	28	29	31
		30 kW	94	106	98	110	106	118	53	55	58	42	44	47
		45 kW	133	151	137	155	145	163	76	77	81	61	62	65
		60 kW	141	160	145	164	152	172	80	82	85	64	66	68

NOTE - All units have a minimum Short Circuit Current Rating (SCCR) of 5000 amps.

<sup>1</sup> Extremes of operating range are plus and minus 10% of line voltage.

<sup>2</sup> HACR type breaker or fuse.

<sup>3</sup> Refer to National or Canadian Electrical Code manual to determine wire, fuse and disconnect size requirements.

<sup>4</sup> Factory installed circuit breaker not available.

**ELECTRICAL/ELECTRIC HEAT DATA**

**15 TON**

Model No.		LCM180U4								
<sup>1</sup> Voltage - 60Hz		208/230V-3ph			460V-3ph			575V-3ph		
Compressor 1	Rated Load Amps	15.7			6.8			5.7		
	Locked Rotor Amps	21			11			12		
Compressor 2	Rated Load Amps	16			7.8			5.7		
	Locked Rotor Amps	110			52			38.9		
Compressor 3	Rated Load Amps	16			7.8			5.7		
	Locked Rotor Amps	110			52			38.9		
Outdoor Fan Motors (4)	Full Load Amps (total)	2.8 (11.2)			1.4 (5.6)			1.1 (4.4)		
Power Exhaust (2) 0.33 HP	Full Load Amps (total)	2.4 (4.8)			1.3 (2.6)			1 (2)		
Service Outlet 115V GFI (amps)		15			15			20		
Indoor Blower Motor	Horsepower	3	5	7.5	3	5	7.5	3	5	7.5
	Full Load Amps	10.6	16.7	24.2	4.8	7.6	11	3.9	6.1	9
<sup>2</sup> Maximum Overcurrent Protection (MOCP)	Unit Only	80	90	110	40	45	50	30	35	40
	With (2) 0.33 HP Power Exhaust	90	100	110	45	45	50	30	35	40
<sup>3</sup> Minimum Circuit Ampacity (MCA)	Unit Only	74	80	90	35	38	42	27	30	33
	With (2) 0.33 HP Power Exhaust	79	85	94	38	41	45	29	32	35

**ELECTRIC HEAT DATA**

		Electric Heat Voltage	208V	240V	208V	240V	208V	240V	480V	480V	480V	600V	600V	600V
<sup>2</sup> Maximum Overcurrent Protection (MOCP)	Unit+ Electric Heat	15 kW	80	80	90	90	110	110	40	45	50	30	35	40
		30 kW	<sup>4</sup> 100	110	<sup>4</sup> 100	125	<sup>4</sup> 110	125	60	60	60	45	45	50
		45 kW	150	150	<sup>4</sup> 150	175	<sup>4</sup> 150	175	80	80	90	60	70	70
		60 kW	<sup>4</sup> 150	175	<sup>4</sup> 150	175	175	175	80	90	90	70	70	70
<sup>3</sup> Minimum Circuit Ampacity (MCA)	Unit+ Electric Heat	15 kW	74	74	80	80	90	90	35	38	42	27	30	33
		30 kW	92	104	100	112	109	121	52	55	59	41	44	48
		45 kW	131	149	139	157	148	166	74	78	82	60	62	66
		60 kW	139	158	146	166	156	175	79	82	86	63	66	69
<sup>2</sup> Maximum Overcurrent Protection (MOCP)	Unit+ Electric Heat and (2) 0.33 HP Power Exhaust	15 kW	90	90	100	100	110	110	45	45	50	30	35	40
		30 kW	<sup>4</sup> 100	110	<sup>4</sup> 110	125	<sup>4</sup> 125	150	60	60	70	45	50	50
		45 kW	<sup>4</sup> 150	175	<sup>4</sup> 150	175	175	175	80	90	90	70	70	70
		60 kW	<sup>4</sup> 150	175	175	175	<sup>4</sup> 175	200	90	90	90	70	70	80
<sup>3</sup> Minimum Circuit Ampacity (MCA)	Unit+ Electric Heat and (2) 0.33 HP Power Exhaust	15 kW	79	79	85	85	94	94	38	41	45	29	32	35
		30 kW	98	110	106	118	115	127	55	58	63	44	47	50
		45 kW	137	155	145	163	154	172	77	81	85	62	65	68
		60 kW	145	164	152	172	162	181	82	85	90	66	68	72

NOTE - All units have a minimum Short Circuit Current Rating (SCCR) of 5000 amps.

<sup>1</sup> Extremes of operating range are plus and minus 10% of line voltage.

<sup>2</sup> HACR type breaker or fuse.

<sup>3</sup> Refer to National or Canadian Electrical Code manual to determine wire, fuse and disconnect size requirements.

<sup>4</sup> Factory installed circuit breaker not available.

**ELECTRICAL/ELECTRIC HEAT DATA**

**17.5 TON**

Model No.		LCM210U4								
<sup>1</sup> Voltage - 60Hz		208/230V-3ph			460V-3ph			575V-3ph		
Compressor 1	Rated Load Amps	13.3			5.9			4.8		
	Locked Rotor Amps	21			11			12		
Compressor 2	Rated Load Amps	14.5			6.3			6		
	Locked Rotor Amps	98			55			41		
Compressor 3	Rated Load Amps	14.5			6.3			6		
	Locked Rotor Amps	98			55			41		
Compressor 4	Rated Load Amps	14.5			6.3			6		
	Locked Rotor Amps	98			55			41		
Outdoor Fan Motors (6)	Full Load Amps (total)	2.8 (16.8)			1.4 (8.4)			1.1 (6.6)		
Power Exhaust (2) 0.33 HP	Full Load Amps (total)	2.4 (4.8)			1.3 (2.6)			1 (2)		
Service Outlet 115V GFI (amps)		15			15			20		
Indoor Blower Motor	Horsepower	3	5	7.5	3	5	7.5	3	5	7.5
	Full Load Amps	10.6	16.7	24.2	4.8	7.6	11	3.9	6.1	9
<sup>2</sup> Maximum Overcurrent Protection (MOCP)	Unit Only	100	110	125	45	50	50	40	40	45
	With (2) 0.33 HP Power Exhaust	100	110	125	45	50	60	40	45	50
<sup>3</sup> Minimum Circuit Ampacity (MCA)	Unit Only	88	95	104	40	43	47	35	38	41
	With (2) 0.33 HP Power Exhaust	93	100	109	43	46	50	37	40	43

**ELECTRIC HEAT DATA**

		Electric Heat Voltage												
		208V	240V	208V	240V	208V	240V	480V	480V	480V	600V	600V	600V	
<sup>2</sup> Maximum Overcurrent Protection (MOCP)	Unit+ Electric Heat	15 kW	100	100	110	110	125	125	45	50	50	40	40	45
		30 kW	<sup>4</sup> 100	110	<sup>4</sup> 110	125	125	125	60	60	60	45	45	50
		45 kW	150	150	<sup>4</sup> 150	175	<sup>4</sup> 150	175	80	80	90	60	70	70
		60 kW	<sup>4</sup> 150	175	<sup>4</sup> 150	175	175	175	80	90	90	70	70	70
		90 kW	<sup>4</sup> 225	250	<sup>4</sup> 225	250	<sup>4</sup> 225	250	125	125	125	100	100	100
<sup>3</sup> Minimum Circuit Ampacity (MCA)	Unit+ Electric Heat	15 kW	88	88	95	95	104	104	40	43	47	35	38	41
		30 kW	92	104	100	112	109	121	52	55	59	41	44	48
		45 kW	131	149	139	157	148	166	74	78	82	60	62	66
		60 kW	139	158	146	166	156	175	79	82	86	63	66	69
		90 kW	201	230	209	238	218	247	115	118	123	92	95	98
<sup>2</sup> Maximum Overcurrent Protection (MOCP)	Unit+ Electric Heat and (2) 0.33 HP Power Exhaust	15 kW	100	100	110	110	125	125	45	50	60	40	45	50
		30 kW	<sup>4</sup> 100	110	<sup>4</sup> 110	125	<sup>4</sup> 125	150	60	60	70	45	50	50
		45 kW	<sup>4</sup> 150	175	<sup>4</sup> 150	175	175	175	80	90	90	70	70	70
		60 kW	<sup>4</sup> 150	175	175	175	<sup>4</sup> 175	200	90	90	90	70	70	80
		90 kW	<sup>4</sup> 225	250	<sup>4</sup> 225	250	<sup>4</sup> 225	<sup>4</sup> 300	125	125	150	100	100	110
<sup>3</sup> Minimum Circuit Ampacity (MCA)	Unit+ Electric Heat and (2) 0.33 HP Power Exhaust	15 kW	93	93	100	100	109	109	43	46	50	37	40	43
		30 kW	98	110	106	118	115	127	55	58	63	44	47	50
		45 kW	137	155	145	163	154	172	77	81	85	62	65	68
		60 kW	145	164	152	172	162	181	82	85	90	66	68	72
		90 kW	207	236	215	244	224	253	118	122	126	94	97	101

NOTE - All units have a minimum Short Circuit Current Rating (SCCR) of 5000 amps.

<sup>1</sup> Extremes of operating range are plus and minus 10% of line voltage.

<sup>2</sup> HACR type breaker or fuse.

<sup>3</sup> Refer to National or Canadian Electrical Code manual to determine wire, fuse and disconnect size requirements.

<sup>4</sup> Factory installed circuit breaker not available.

**ELECTRICAL/ELECTRIC HEAT DATA**

**20 TON**

Model No.		LCM240U4								
<sup>1</sup> Voltage - 60Hz		208/230V-3ph			460V-3ph			575V-3ph		
Compressor 1	Rated Load Amps	16.8			7.8			6.2		
	Locked Rotor Amps	21			11			12		
Compressor 2	Rated Load Amps	13.2			6.3			4.9		
	Locked Rotor Amps	93			60			41		
Compressor 3	Rated Load Amps	13.2			6.3			4.9		
	Locked Rotor Amps	93			60			41		
Compressor 4	Rated Load Amps	13.2			6.3			4.9		
	Locked Rotor Amps	93			60			41		
Outdoor Fan Motors (6)	Full Load Amps (total)	2.8 (16.8)			1.4 (8.4)			1.1 (6.6)		
Power Exhaust (2) 0.33 HP	Full Load Amps (total)	2.4 (4.8)			1.3 (2.6)			1 (2)		
Service Outlet 115V GFI (amps)		15			15			20		
Indoor Blower Motor	Horsepower	5	7.5	10	5	7.5	10	5	7.5	10
	Full Load Amps	16.7	24.2	30.8	7.6	11	14	6.1	9	11
<sup>2</sup> Maximum Overcurrent Protection (MOCP)	Unit Only	110	125	125	50	50	60	40	45	50
	With (2) 0.33 HP Power Exhaust	110	125	125	50	60	60	40	45	50
<sup>3</sup> Minimum Circuit Ampacity (MCA)	Unit Only	95	104	112	45	49	53	36	39	42
	With (2) 0.33 HP Power Exhaust	99	109	117	48	52	56	38	41	44

**ELECTRIC HEAT DATA**

		Electric Heat Voltage												
		208V	240V	208V	240V	208V	240V	480V	480V	480V	600V	600V	600V	
<sup>2</sup> Maximum Overcurrent Protection (MOCP)	Unit+ Electric Heat	<b>15 kW</b>	110	110	125	125	125	125	50	50	60	40	45	50
		<b>30 kW</b>	<sup>4</sup> 110	125	125	125	<sup>4</sup> 125	150	60	60	70	45	50	50
		<b>45 kW</b>	<sup>4</sup> 150	175	<sup>4</sup> 150	175	175	175	80	90	90	70	70	70
		<b>60 kW</b>	<sup>4</sup> 150	175	175	175	<sup>4</sup> 175	200	90	90	90	70	70	80
		<b>90 kW</b>	<sup>4</sup> 225	250	<sup>4</sup> 225	250	<sup>4</sup> 250	<sup>4</sup> 300	125	125	150	100	100	110
<sup>3</sup> Minimum Circuit Ampacity (MCA)	Unit+ Electric Heat	<b>15 kW</b>	95	95	104	104	112	112	45	49	53	36	39	42
		<b>30 kW</b>	100	112	109	121	117	129	55	59	63	44	48	50
		<b>45 kW</b>	139	157	148	166	156	174	78	82	86	62	66	68
		<b>60 kW</b>	146	166	156	175	164	183	82	86	90	66	69	72
		<b>90 kW</b>	209	238	218	247	227	256	118	123	126	95	98	101
<sup>2</sup> Maximum Overcurrent Protection (MOCP)	Unit+ Electric Heat and (2) 0.33 HP Power Exhaust	<b>15 kW</b>	110	110	125	125	125	125	50	60	60	40	45	50
		<b>30 kW</b>	<sup>4</sup> 110	125	<sup>4</sup> 125	150	<sup>4</sup> 125	150	60	70	70	50	50	60
		<b>45 kW</b>	<sup>4</sup> 150	175	175	175	<sup>4</sup> 175	200	90	90	90	70	70	80
		<b>60 kW</b>	175	175	<sup>4</sup> 175	200	<sup>4</sup> 175	200	90	90	100	70	80	80
		<b>90 kW</b>	<sup>4</sup> 225	250	<sup>4</sup> 225	<sup>4</sup> 300	<sup>4</sup> 250	<sup>4</sup> 300	125	150	150	100	110	110
<sup>3</sup> Minimum Circuit Ampacity (MCA)	Unit+ Electric Heat and (2) 0.33 HP Power Exhaust	<b>15 kW</b>	99	99	109	109	117	117	48	52	56	38	41	44
		<b>30 kW</b>	106	118	115	127	123	135	58	63	66	47	50	53
		<b>45 kW</b>	145	163	154	172	162	180	81	85	89	65	68	71
		<b>60 kW</b>	152	172	162	181	170	189	85	90	93	68	72	74
		<b>90 kW</b>	215	244	224	253	233	262	122	126	130	97	101	103

NOTE - All units have a minimum Short Circuit Current Rating (SCCR) of 5000 amps.

<sup>1</sup> Extremes of operating range are plus and minus 10% of line voltage.

<sup>2</sup> HACR type breaker or fuse.

<sup>3</sup> Refer to National or Canadian Electrical Code manual to determine wire, fuse and disconnect size requirements.

<sup>4</sup> Factory installed circuit breaker not available.

**ELECTRICAL/ELECTRIC HEAT DATA**

**25 TON**

Model No.		LCM300U4								
<sup>1</sup> Voltage - 60Hz		208/230V-3ph			460V-3ph			575V-3ph		
Compressor 1	Rated Load Amps	16.8			8.9			7.1		
	Locked Rotor Amps	21			11			12		
Compressor 2	Rated Load Amps	19.6			8.2			6.6		
	Locked Rotor Amps	136			66.1			55.3		
Compressor 3	Rated Load Amps	22.4			10.6			7.7		
	Locked Rotor Amps	149			75			54		
Compressor 4	Rated Load Amps	22.4			10.6			7.7		
	Locked Rotor Amps	149			75			54		
Outdoor Fan Motors (6)	Full Load Amps (total)	2.8 (16.8)			1.4 (8.4)			1.1 (6.6)		
Power Exhaust (2) 0.33 HP	Full Load Amps (total)	2.4 (4.8)			1.3 (2.6)			1 (2)		
Service Outlet 115V GFI (amps)		15			15			20		
Indoor Blower Motor	Horsepower	5	7.5	10	5	7.5	10	5	7.5	10
	Full Load Amps	16.7	24.2	30.8	7.6	11	14	6.1	9	11
<sup>2</sup> Maximum Overcurrent Protection (MOCP)	Unit Only	125	150	150	60	70	70	50	50	60
	With (2) 0.33 HP Power Exhaust	150	150	150	70	70	80	50	50	60
<sup>3</sup> Minimum Circuit Ampacity (MCA)	Unit Only	121	129	137	57	61	65	44	47	50
	With (2) 0.33 HP Power Exhaust	126	134	142	60	64	67	46	49	52

**ELECTRIC HEAT DATA**

Electric Heat Voltage		208V	240V	208V	240V	208V	240V	480V	480V	480V	600V	600V	600V	
<sup>2</sup> Maximum Overcurrent Protection (MOCP)	Unit+ Electric Heat	<b>15 kW</b>	125	125	150	150	150	60	70	70	50	50	60	
		<b>30 kW</b>	125	125	150	150	150	80	90	90	50	50	60	
		<b>45 kW</b>	<sup>4</sup> 150	175	<sup>4</sup> 150	175	175	175	90	90	90	70	70	70
		<b>60 kW</b>	<sup>4</sup> 150	175	175	175	<sup>4</sup> 175	200	125	125	150	70	70	80
		<b>90 kW</b>	<sup>4</sup> 225	250	<sup>4</sup> 225	250	<sup>4</sup> 250	<sup>4</sup> 300	175	175	175	100	100	110
<sup>3</sup> Minimum Circuit Ampacity (MCA)	Unit+ Electric Heat	<b>15 kW</b>	121	121	129	129	137	137	57	61	65	44	47	50
		<b>30 kW</b>	121	121	129	129	137	137	78	82	86	44	48	50
		<b>45 kW</b>	139	157	148	166	156	174	82	86	90	62	66	68
		<b>60 kW</b>	146	166	156	175	164	183	118	123	126	66	69	72
		<b>90 kW</b>	209	238	218	247	227	256	154	159	162	95	98	101
<sup>2</sup> Maximum Overcurrent Protection (MOCP)	Unit+ Electric Heat and (2) 0.33 HP Power Exhaust	<b>15 kW</b>	150	150	150	150	150	70	70	80	50	50	60	
		<b>30 kW</b>	150	150	150	150	150	90	90	90	50	50	60	
		<b>45 kW</b>	<sup>4</sup> 150	175	175	175	<sup>4</sup> 175	200	90	90	100	70	70	80
		<b>60 kW</b>	175	175	<sup>4</sup> 175	200	<sup>4</sup> 175	200	125	150	150	70	80	80
		<b>90 kW</b>	<sup>4</sup> 225	250	<sup>4</sup> 225	<sup>4</sup> 300	<sup>4</sup> 250	<sup>4</sup> 300	175	175	175	100	110	110
<sup>3</sup> Minimum Circuit Ampacity (MCA)	Unit+ Electric Heat and (2) 0.33 HP Power Exhaust	<b>15 kW</b>	126	126	134	134	142	142	60	64	67	46	49	52
		<b>30 kW</b>	126	126	134	134	142	142	81	85	89	47	50	53
		<b>45 kW</b>	145	163	154	172	162	180	85	90	93	65	68	71
		<b>60 kW</b>	152	172	162	181	170	189	122	126	130	68	72	74
		<b>90 kW</b>	215	244	224	253	233	262	158	162	166	97	101	103

NOTE - All units have a minimum Short Circuit Current Rating (SCCR) of 5000 amps.

<sup>1</sup> Extremes of operating range are plus and minus 10% of line voltage.

<sup>2</sup> HACR type breaker or fuse.

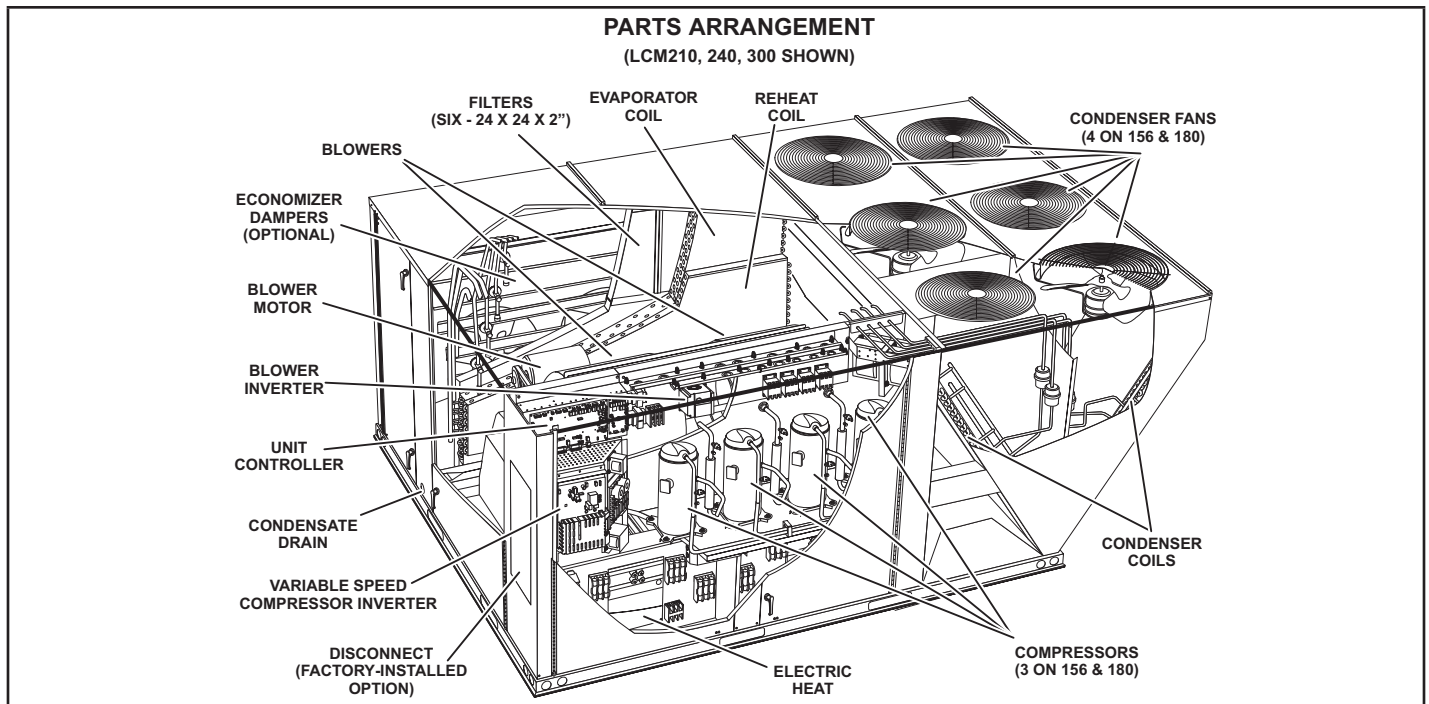
<sup>3</sup> Refer to National or Canadian Electrical Code manual to determine wire, fuse and disconnect size requirements.

<sup>4</sup> Factory installed circuit breaker not available.



## ELECTRIC HEAT CAPACITIES

Volts Input	15 kW			30 kW			45 kW			60 kW			90 kW		
	kW Input	Btuh Output	No. of Stages	kW Input	Btuh Output	No. of Stages	kW Input	Btuh Output	No. of Stages	kW Input	Btuh Output	No. of Stages	kW Input	Btuh Output	No. of Stages
208	11.3	38,600	1	22.5	76,800	1	33.8	115,300	2	45.0	153,600	2	67.6	230,700	2
220	12.6	43,000	1	25.2	86,000	1	37.8	129,000	2	50.4	172,000	2	75.6	258,000	2
230	13.8	47,100	1	27.5	93,900	1	41.3	141,000	2	55.1	188,000	2	82.7	282,200	2
240	15.0	51,200	1	30.0	102,400	1	45.0	153,600	2	60.0	204,800	2	90.0	307,100	2
440	12.6	43,000	1	25.2	86,000	1	37.8	129,000	2	50.4	172,000	2	75.6	258,000	2
460	13.8	47,100	1	27.5	93,900	1	41.3	141,000	2	55.1	188,000	2	82.7	282,200	2
480	15.0	51,200	1	30.0	102,400	1	45.0	153,600	2	60.0	204,800	2	90.0	307,100	2
550	12.6	43,000	1	25.2	86,000	1	37.8	129,000	2	50.4	172,000	2	75.6	258,000	2
575	13.8	47,100	1	27.5	93,900	1	41.3	141,000	2	55.1	188,000	2	82.7	282,200	2
600	15.0	51,200	1	30.0	102,400	1	45.0	153,600	2	60.0	204,800	2	90.0	307,100	2



**FIGURE 1**

**I-UNIT COMPONENTS**

**⚠ CAUTION**

**As with any mechanical equipment, contact with sharp sheet metal edges can result in personal injury. Take care while handling this equipment and wear gloves and protective clothing.**

All 13 through 25 ton (45.7 through 88 kW) units are configure to order units (CTO). Unit components are shown in figures 1. All units come standard with hinged unit panels. The unit panels may be held open with the door rod located inside the unit. All L1, L2 and L3 wiring is color coded; L1 is red, L2 is yellow and L3 is blue.

**A-Control Box Components**

**ELECTROSTATIC DISCHARGE (ESD)  
Precautions and Procedures**

**⚠ CAUTION**

**Electrostatic discharge can affect electronic components. Take precautions to neutralize electrostatic charge by touching your hand and tools to metal prior to handling the control.**

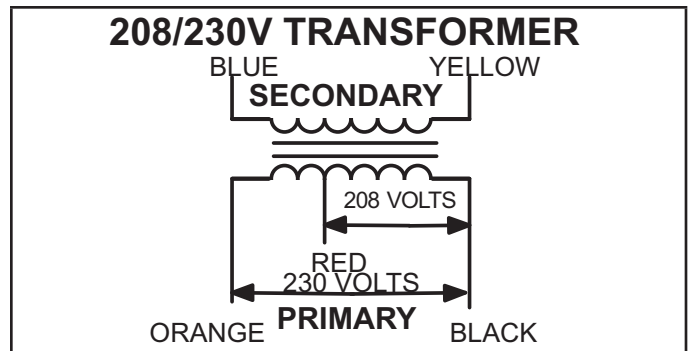
Control box components are shown in figure 3. The control box is located in the upper portion of the compressor compartment.

**1-Disconnect Switch S48**

Units with higher SCCR rating may be equipped with an disconnect switch S48. Other factory or field installed optional circuit breakers may be used, such as CB10. S48 and CB10 are toggle or twist-style switches, which can be used by the service technician to disconnect power to the unit.

**2-Control Transformer T1**

All use a single line voltage to 24VAC transformer mounted in the control box. Transformer supplies power to control circuits in the unit. The transformer is rated at 70VA and is protected by a 3.5 amp circuit breaker (CB8). The 208/230 (Y) voltage transformers use two primary voltage taps as shown in figure 2, while 460 (G) and 575 (J) voltage transformers use a single primary voltage tap.



**FIGURE 2**

**3-Contactor Transformer T18**

T18 is a single line voltage to 24VAC transformer used in all LCM 13 to 25 ton units. Transformer T18 is protected by a 3.5 amp circuit breaker (CB18). T18 is identical to transformer T1. The transformer supplies 24VAC power to the contactors.

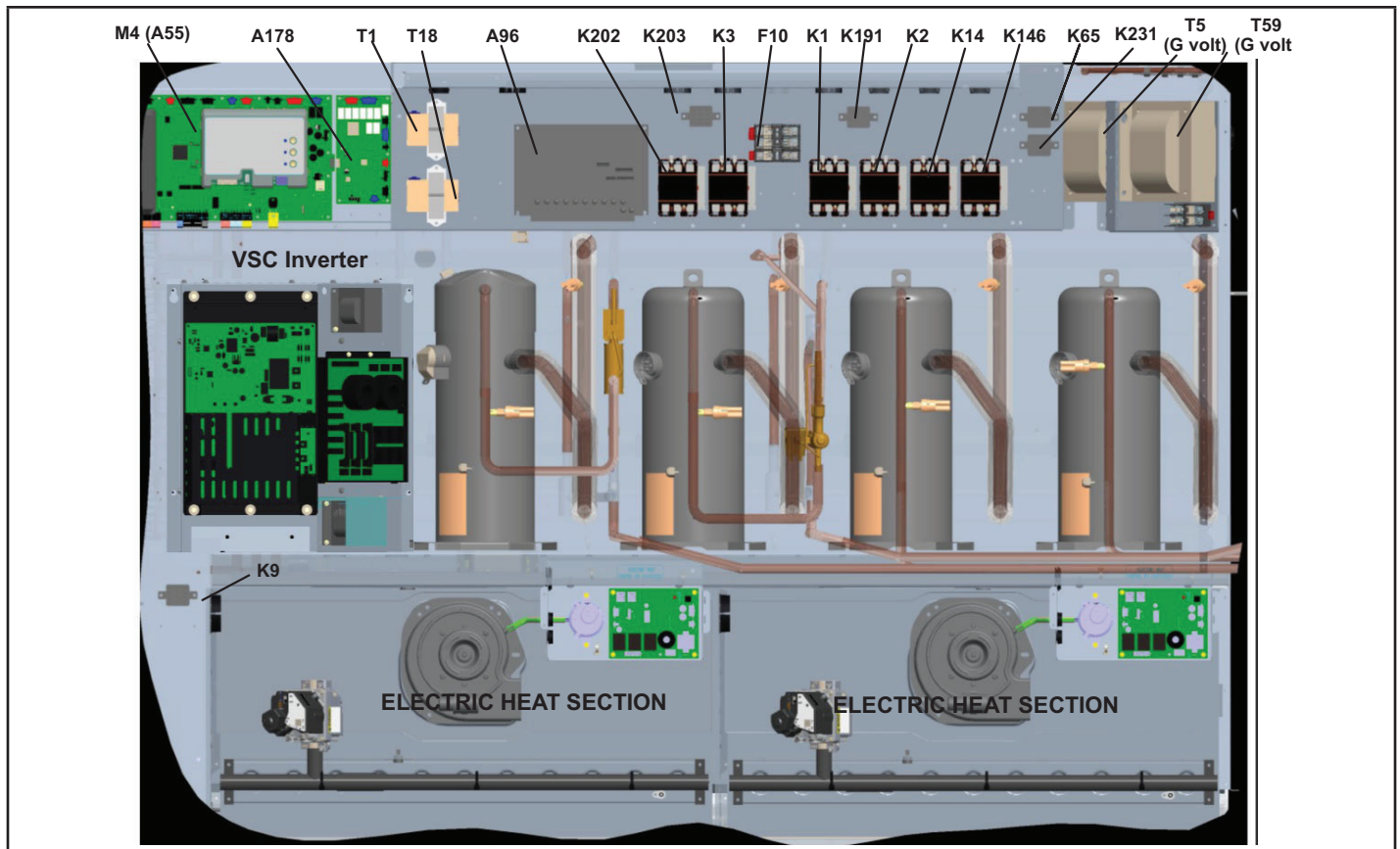


FIGURE 3

#### 4-Terminal Block TB13

TB13 terminal block distributes line voltage power to the line voltage items in the unit.

#### 5-Outdoor Fan Motor Fuse Block & Fuses F10 Power Exhaust Fan Motor Fuse Block and Fuses F6.

STD SCCR 240V, 300V and higher rated SCCR units have three line voltage fuses F10 provide overcurrent protection to all condenser fans. Two line voltage fuses F6 provide overcurrent protection to the two optional power exhaust fans. The fuses are rated at 30A in all 208/230V units but 10A in the 208/230V 240U and 300U models.

#### 6-Compressor Contactor K1, K2, K14, K146

K1, K2, K14: All units

K146: 210, 240, 300

All compressor contactors are three-pole-double-break contactors with 24VAC coils. K1 and K2 (energized by A55) energizes compressors B1 and B2 in response to first stage cool demand. In 180 units K14 (energized by A178) energizes B13 in response to second stage cool demand. In 210, 240 and 300 units K14 and K146 (energized by A178) energize compressors B13 and B20 in response to second stage cool demand.

#### 7-Blower Contactor K3

Blower contactor K3, used in all units, is a three-pole-doublebreak contactor with a 24VAC coil used to energize the indoor blower motor B3 in response to blower demand. K3 is energized by Unit Controller (A55). Optional Staged-Blower units which are not equipped with a bypass option will not have a K3.

#### 8-Ultraviolet Germicidal Lamp (UVC) Transformer T49

UVC transformer T49 is used by units of all voltages except 208/230V and 575V which are equipped with a UVC. The auto voltage to 230VAC transformer is installed in the control box. The transformer has an output rating of 0.5 amps. T49 transformer supplies 230VAC power to the UVC lamp.

#### 9-Power Exhaust Relay K65 & K231 (PED units)

Power exhaust relays K65 and K231 are N.O. DPDT relays with a 24VAC coil. The relays are used in units equipped with the optional power exhaust dampers. K65 and K231 are energized by the A55 Unit Controller, after the economizer dampers reach 50% open (adjustable in ECTO). When K65 closes, exhaust fan B10 is energized and when K231 closes B11 is energized.

### 10-Variable Frequency Drive A96 (optional)

Staged-Blower units are equipped with a VFD which alters the supply power frequency and voltage to the blower motor. Blower speed is staged depending on the compressor stages, heating demand, ventilation demand, or smoke alarm. The amount of airflow for each stage is preset from the factory. Airflow can be adjusted by changing ECTO parameters in the A55 Unit Controller. The VFD is located below the Unit Controller.

### 11-VFD Power To Motor Contactor K202 (optional)

Contactor is used in Staged-Blower units equipped with a VFD bypass option. The three-pole 40 amp contactor with a 24VAC coil is energized by the A55 Unit Controller. K202 allows power from the VFD to the B3 blower motor in response to blower demand.

### 12-Inverter Start Forward Rotation Relay K203 (option)

Relay is used in optional Staged-Blower units and is a three-pole double-throw relay with a 24VAC coil. K203 is energized by the A55 Unit Controller and provides input to the A96 VFD to start blower forward rotation. K203 also deenergizes K3 allowing A96 to control B3 blower.

### 13-Unit Controller A55

The Unit Controller provides all unit control functions, unit status information, unit diagnostics, programmable parameters and USB verification and profile sharing. Refer to the Unit Controller guide provided with the unit. Thermostat wires are connected to J297 on the Unit Controller.

### 14-Compressor 3 & 4 Controller A59 & A178

The compressor 3 & 4 control module A59 controls two additional compressor stages. A59 includes all inputs and outputs required for compressor and fan control, compressor stage diagnostics and low ambient control. The M3 unit controller is only compatible with L-Connection sensors provided with the unit or purchased separately as specified in the Product Specification. Tables 1 through 4 show thermistor and pressure transducer readings.

### Temperature Sensors

The return air (RT16) and discharge air (RT6) duct probes and the outdoor air (RT17) are all two wire thermistors. The resistance vs. temperature table is shown below:

**TABLE 1**  
**Resistance vs. Temperature**

Temp. °F (°C)	Resistance +/-2%	Temperature °F (°C)	Resistance +/-2%	Temp. °F (°C)	Resistance +/-2%
-40 (-40)	335,671	40 (4.4)	26,106	90 (32.2)	7,332
-20 (-28.9)	164,959	50 (10)	19,904	100 (37.8)	5,826
0 (-17.8)	85,323	60 (15.6)	15,313	120 (48.9)	3,756
20 (-6.7)	46,218	70 (21.1)	11,884	130 (54.4)	3,047
30 (-1.1)	34,566	80 (26.7)	9,298		

### Room Sensors

Room sensor (A2) is a two-wire thermistor with 1k series resistor.

**TABLE 2**  
**Two-Wire Thermistor**

Temp. °F (°C)	Resistance +/-2%	Temperature °F (°C)	Resistance +/-2%	Temp. °F (°C)	Resistance +/-2%
40 (4.4)	27,102	60 (15.6)	16,313	80 (26.7)	10,299
45 (7.2)	23,764	65 (18.3)	14,474	85 (29.4)	9,249
50 (10)	20,898	70 (21.1)	12,882	90 (32.2)	8,529
55 (12.8)	18,433	75 (23.9)	11,498		

### Carbon Dioxide Sensor

The indoor carbon dioxide sensor (A63) is an analog sensor with a 0-10VDC output over a carbon dioxide range of 0-2000 ppm as shown in the following table. The sensor is powered with 24VAC.

**TABLE 3**  
**Carbon Dioxide Range**

Carbon Dioxide PPM	DCV	Carbon Dioxide PPM	DC Voltage	Carbon Dioxide PPM	DC Voltage	Carbon Dioxide PPM	DCV
0	0	600	3	1200	6	1800	9
200	1	800	4	1400	7	2000	10
400	2	1000	5	1600	8		

### VAV Supply Static Sensor

The supply duct differential static pressure sensor (A30) is an analog sensor with a 0-10VDC output over a range of 0-5" w.c. as shown in the following table. The sensor is powered with 24VAC.

**TABLE 4**  
**Static Pressure**

Pressure "w.c.	DCV	Pressure "w.c.	DC Voltage	Pressure "w.c.	DC Voltage	Pressure "w.c.	DCV
0	0	1.5	3	3	6	4.5	9
0.5	1	2	4	3.5	7	5	10
1	2	2.5	5	4	8		

### Relative Humidity Sensor - Optional

The indoor relative humidity sensor (A91) is an analog sensor with a 0-10VDC output over a relative humidity range of 0-100% relative humidity. The sensor is powered with 24VAC.

### Enthalpy Sensor - Optional

The optional enthalpy sensors (A7 and A63) used with the economizer have an output of 4-20mA. The sensor is powered with 18VAC provided by M3 unit control.

### Economizer Differential Pressure Sensor - Optional

Rooftop units installed with Smart Airflow™ will have a Pressure Transducer (PT5) present in the economizer. PT5 requires 5VDC power supply (P266-5 and P266-6) and gives 0.25 VDC to 4 VDC output (P266-4) corresponding to 0" water column and 2" water column respectively. For all practical purposes the output should be less than 1.2" water column if not an error code is stored and service alarm output is turned on.

### 15-Second-Stage Power Exhaust Relay K231 (Staged-Blower units equipped with power exhaust)

The second power exhaust fan is controlled by K231. A133 will enable K231 only when the blower reaches 70% of full speed (adjustable ECTO). This prevents a negative

building pressure when the blower is operating in low speed. Refer to the Unit Controller manual and ECTO labels on the unit.

### 16-Outdoor Fan Transformers T5, T59 (460V units)

All 460 (G) voltage units use transformer T5 and T59. The auto voltage to 230VAC transformers are mounted in the control box. The transformers have an output rating of 0.5A. T5 transformer supplies 230 VAC power to outdoor fans B4, B5 and B21. T59 transformer supplies 230V to outdoor fans B22, B23 and B24.

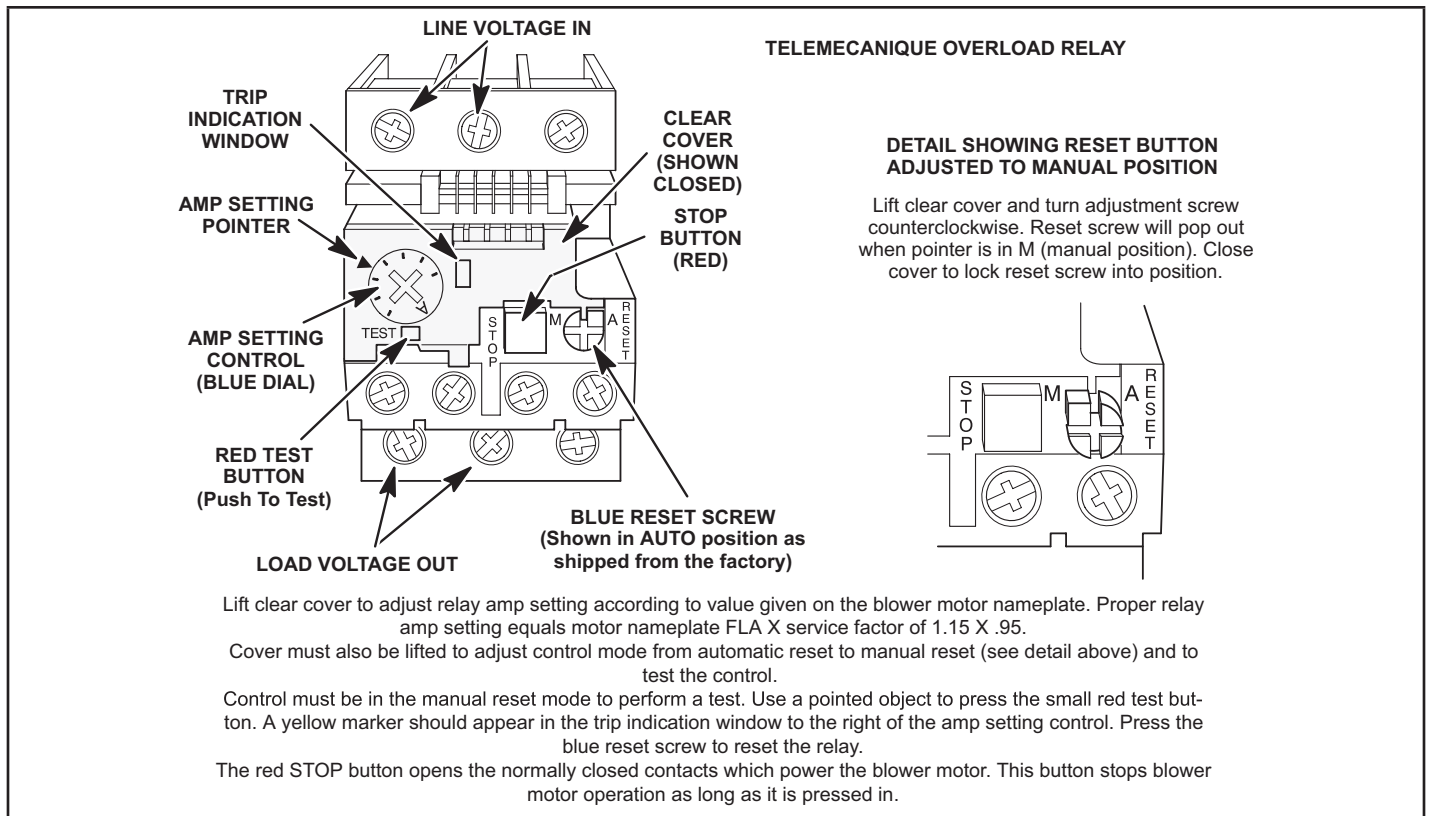
### 17-Fuse F61 (Higher SCCR units only)

Fuse F61 is used on units with higher SCCR rating. F61 provides overcurrent protection to compressor and other cooling components. F61 and S48 are located inside a sheet metal enclosure in the unit left front corner mullion.

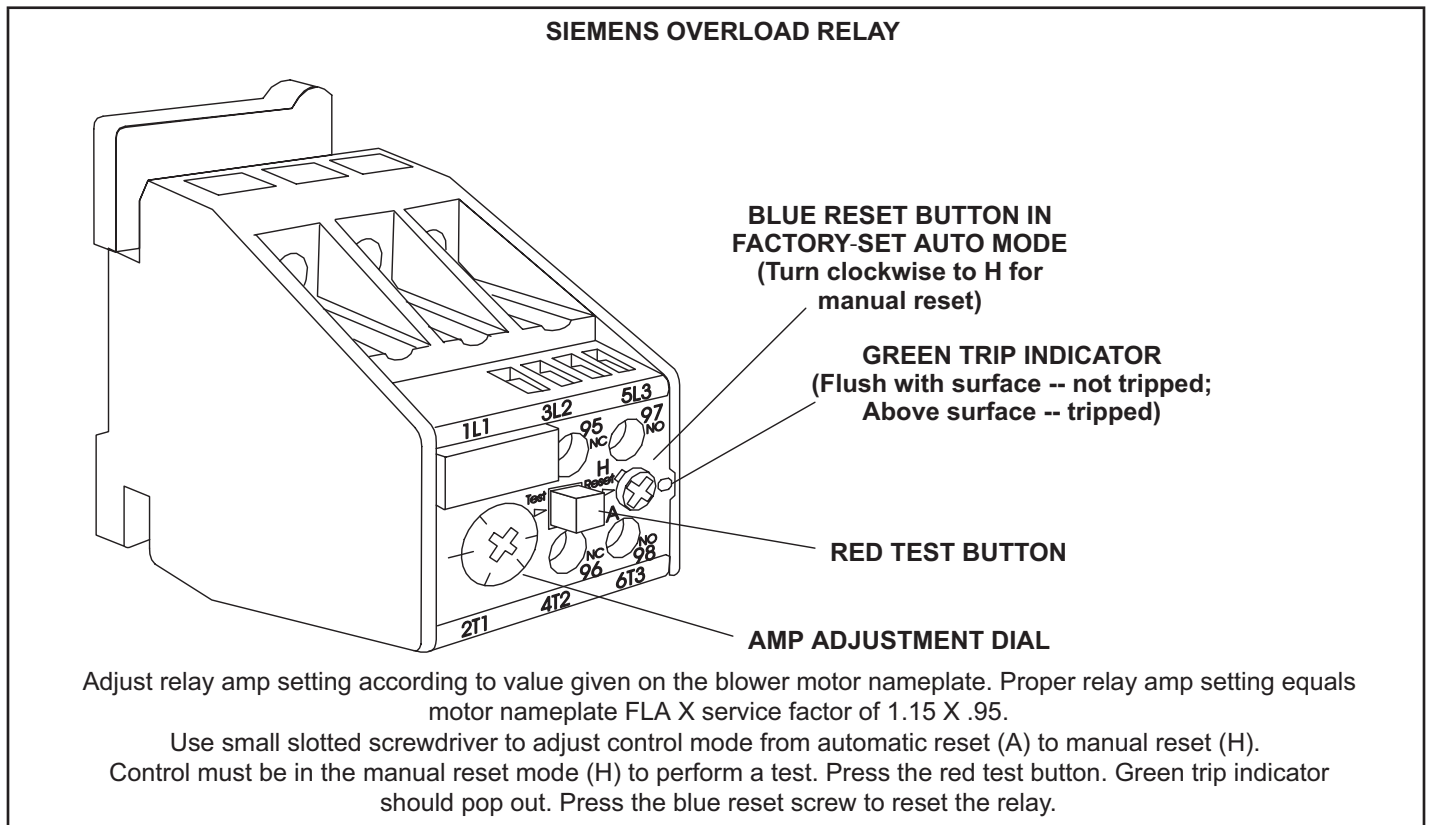
### 18-Blower Motor Overload Relay S42

The relay (S42) is connected in line with the blower motor to monitor the current flow to the motor. When the relay senses an overload condition, a set of normally closed contacts open to de-energize pin #1 in plug P299 of the A55 Unit Controller. A55 de-energizes all outputs. Units will be equipped with a relay manufactured by Telemechanique figure 4 or Siemens figure 5.





**FIGURE 4**



**FIGURE 5**



Compressor Detail  
LCM156/300 B1, B2, B13  
LCM210/300 B20

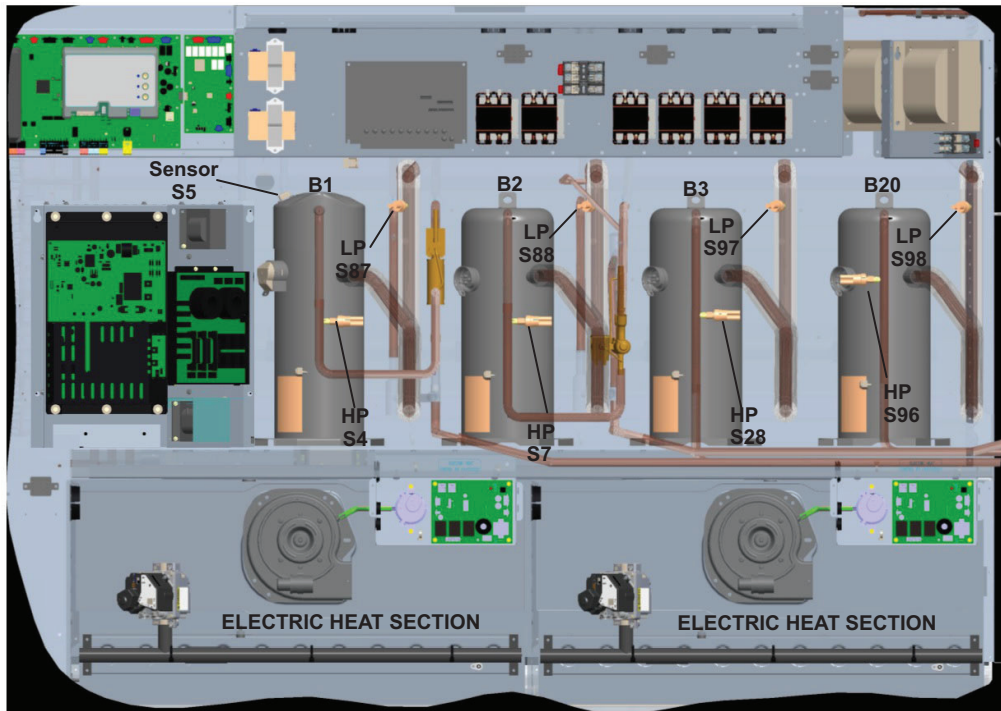
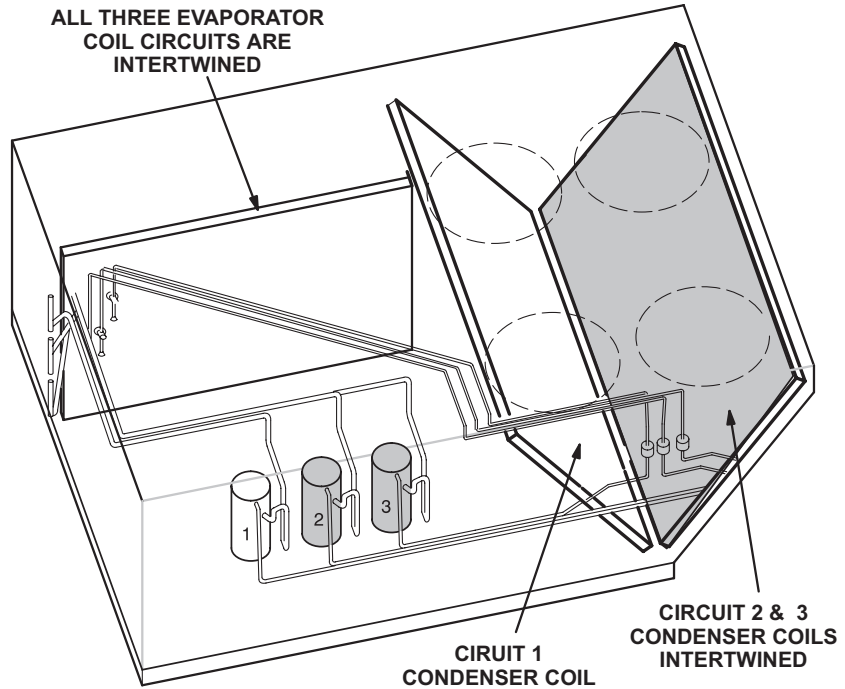
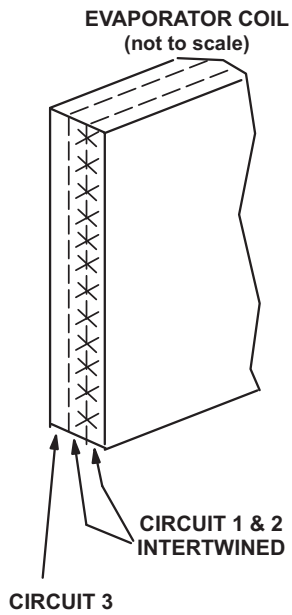


FIGURE 6

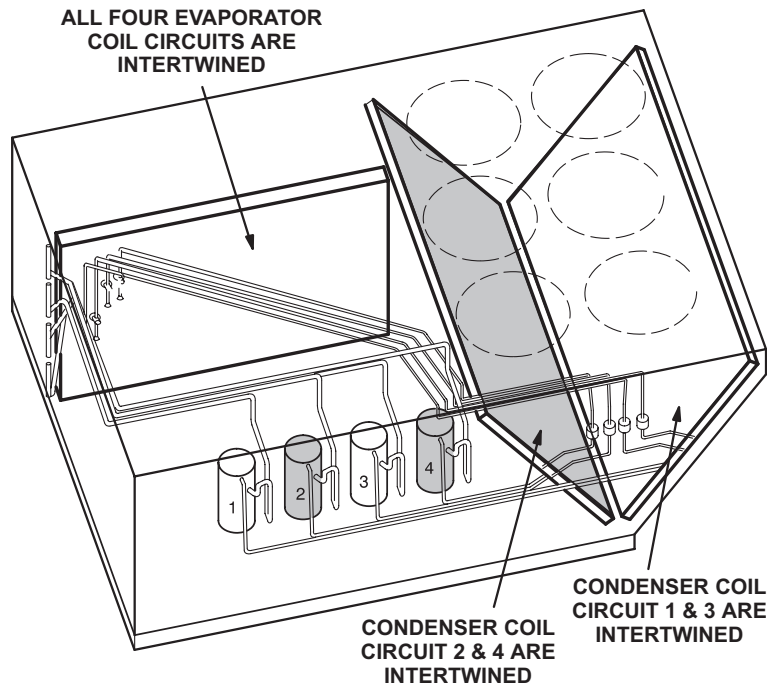
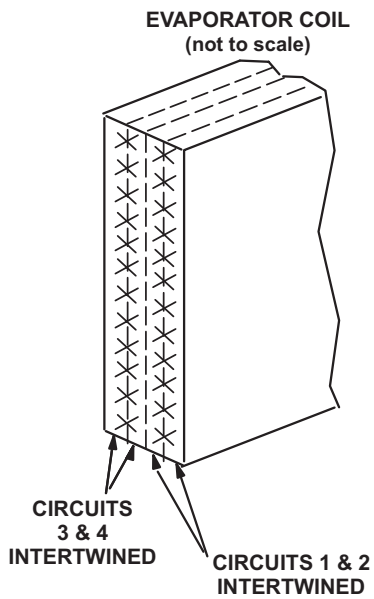
**156, 180 REFRIGERANT CIRCUITS**

ALL THREE EVAPORATOR  
COIL CIRCUITS ARE  
INTERTWINED



**210, 240, 300 REFRIGERANT CIRCUITS**

ALL FOUR EVAPORATOR  
COIL CIRCUITS ARE  
INTERTWINED



**FIGURE 7**

## B-Cooling Components

Model L ultra high efficiency units use independent cooling circuits consisting of one compressor, one condenser coil, and one evaporator coil per circuit. See figures 7 and 6.

Four draw-through type condenser fans are used in LCM156, 180 units and six draw-through type condenser fans are used in LCM210, 240 and 300 units.

Cooling may be supplemented by a factory- or field-installed economizer. All units use an intertwined evaporator. Each evaporator uses a thermostatic expansion valve as the primary expansion device. Each evaporator is also equipped with enhanced fins and rifled tubing. In all units each compressor is protected by a crankcase heater, high pressure switch and low pressure switch.

### 1-Compressors B1, B2, B13, B20

All units use scroll compressors. LCM156 and 180 use 3 compressors and LCM210, 240 and 300 use four compressors. Compressor capacity may vary from stage to stage. In all cases, the capacity of each compressor is added to reach the total capacity of the unit. See "SPECIFICATIONS" and "ELECTRICAL DATA" (table of contents) or compressor nameplate for compressor specifications.

## WARNING

**Electrical shock hazard. Compressor must be grounded. Do not operate without protective cover over terminals. Disconnect power before removing protective cover. Discharge capacitors before servicing unit. Failure to follow these precautions could cause electrical shock resulting in injury or death.**

Each compressor is energized by a corresponding compressor contactor.

**NOTE-Refer to the wiring diagram section for specific unit operation.**

If a compressor replacement is necessary, call 1-800-453-6669.

## IMPORTANT

**Some scroll compressors have an internal vacuum protector that will unload scrolls when suction pressure goes below 20 psig. A hissing sound will be heard when the compressor is running unloaded. Protector will reset when low pressure in system rises above 40 psig. DO NOT REPLACE COMPRESSOR.**

### 2-Crankcase Heaters HR1, HR2, HR5 & HR11

All LGM units use insertion type heaters. Heater HR1 is installed around compressor B1, heater HR2 compressor B2, HR5 compressor B13 and HR11 compressor B20.

## 3-High Pressure Switches S4, S7, S28, S96

S4 all units

S7 all units

S28 all units

S96 210, 240, 300

The high pressure switches is an auto-reset SPST N.C. switch which opens on a pressure rise. All units are equipped with this switch. The switch is located in the compressor discharge line and is wired in series with the compressor contactor coil through A55 unit controller or A178 compressor 3 and 4 controller. See figure 6.

S4 and S7 are is wired in series with B1 and B2 compressor contactors and S28 and S96 are wired in series with B13 and B20 compressor contactors.

When discharge pressure rises to  $640 \pm 10$  psig ( $4413 \pm 69$  kPa) (indicating a problem in the system) the switch opens and the respective compressor(s) is de-energized (the economizer can continue to operate). When discharge pressure drops to  $475 \pm 20$  psig ( $3275 \pm 138$  kPa) the pressure switch will close re-energizing the compressor(s).

Main control A55 has a three-strike counter before locking out. This means the control allows three high pressure trips per one thermostat demand. The control can be reset by breaking and remaking the thermostat demand or manually resetting the control.

### 4-Low Pressure Switches S87, S88, S97, S98

S87 all units

S88 all units

S97 210, 240, 300

S98 all units

The low pressure switch is an auto-reset SPST N.O. switch (held N.C. by refrigerant pressure) which opens on a pressure drop. All units are equipped with this switch. The switch is located in the compressor suction line. See figure 6.

S87 and S88 (compressor one and two) and S98 (compressor three) and S98 (compressor 4) are wired in series with the contactor coils through the A55 Unit Controller

The Unit Controller A55 governs the low pressure switches by shunting the switches during start up until pressure is stabilized. After the shunt period, the control has a three-strike counter, during a single thermostat demand, before the compressor(s) is locked out. The control is reset by breaking and remaking the thermostat demand or manually resetting the control.

When suction pressure drops to  $40 + 5$  psig ( $276 \pm 34$  kPa), (indicating low pressure), the switch opens and the compressor(s) is de-energized. The switch automatically resets when pressure in the suction line rises to  $90 + 5$  psig ( $620 \pm 34$  kPa).

### 5-Service Valve (optional)

Units may be equipped with service valves located in the discharge and liquid lines. The service valves are manually operated valves used for service operation.

## 6-Filter Drier (all units)

Units have a filter drier located in the liquid line of each refrigerant circuit at the exit of each condenser coil. The drier removes contaminants and moisture from the system.

## 7-Condenser Fans B4, B5, B21, B22 (all units) B23, B24 (210, 240, 300)

See SPECIFICATIONS tables at the front of this manual for specifications of condenser fans used in all units. All condenser fans used have single-phase motors. The fan assembly may be removed for servicing and cleaning.

## 8-High Temperature Sensor S5

S5 is a high temperature sensor installed in variable speed compressor B1 only. The sensor is wired in series with high pressure switch S4. When opened due to high temperature the compressor is de-energized.

## 9-Temperature Thermistor RT42/57

Temperature thermistors are located on specific points for each refrigeration circuit. Temperature thermistors provide continuous temperature input to the unit controller for proper cooling operation as well as system protection. Controller logic will de-energize compressors for each refrigeration circuit when evaporator coil temperature falls below 32°F (0°C) to prevent evaporator freeze-up

## C-Blower Compartment

The blower compartment is located between the evaporator coil and the compressor / control section on the opposite side of the condenser coil. The blower assembly is accessed by disconnecting the blower motor wiring (and all other plugs) and removing the screws on either side of the sliding base. The base pulls out as shown in figure 9.

### 1-Blower Wheels

All units have two 15 in. x 15 in. (381 mm x 381 mm) blower wheels. Both wheels are driven by one motor.

### 2-Indoor Blower Motor B3

All units use three-phase single-speed blower motors. CFM adjustments are made by adjusting the motor pulley (sheave). Motors are equipped with sealed ball bearings. All motor specifications are listed in the SPECIFICATIONS (table of contents) in the front of this manual. Units may be equipped with motors manufactured by various manufacturers, therefore electrical FLA and LRA specifications will vary. See unit rating plate for information specific to your unit.

## OPERATION / ADJUSTMENT

**Supply Air Staged Units** - The blower rotation will always be correct on units equipped with an inverter. Checking blower rotation is not a valid method of determining voltage phasing for incoming power.

**Supply Air Staged Units and Units Equipped With Optional Voltage or Phase Detection** - The Unit Controller checks the incoming power during start-up. If the voltage or phase is incorrect, the Unit Controller will display an alarm and the unit will not start.

## A-Blower Operation

Refer to the Unit Controller Setup Guide to energize blower. Use this mobile service app (the QR is located in the control area) menu:

SERVICE > TEST > BLOWER

Instructions provided with the thermostat may also be used to initiate blower only (G) demand. Unit will cycle on thermostat demand. The following steps apply to applications using a typical electro-mechanical thermostat.

1. Blower operation is manually set at the thermostat sub-base fan switch. With fan switch in **ON** position, blowers will operate continuously.
2. With fan switch in **AUTO** position, the blowers will cycle with demand. Blowers and entire unit will be off when system switch is in **OFF** position.

## IMPORTANT

### Three Phase Scroll Compressor Voltage Phasing

Three phase scroll compressors must be phased sequentially to ensure correct compressor and blower\* rotation and operation. Compressor and blower are wired in phase at the factory. Power wires are color-coded as follows: line 1-red, line 2-yellow, line 3-blue.

1-Observe suction and discharge pressures and blower\* rotation on unit start-up.

2-Suction pressure must drop, discharge pressure must rise and blower\* rotation must match rotation marking.

If pressure differential is not observed or blower\* rotation is not correct:

3-Disconnect all remote electrical power supplies.

4-Reverse any two field-installed wires connected to the line side of S48 disconnect or TB13 terminal strip. Do not reverse wires at blower contactor.

5-Make sure the connections are tight.

Discharge and suction pressures should operate at their normal start-up ranges.

\*Supply air inverter blower motors should rotate in the correct direction; verify scroll compressor rotation separately. Contact technical support if the blower is rotating incorrectly.

## ⚠ IMPORTANT

- 1-Make sure that unit is installed in accordance with the installation instructions and applicable codes.
- 2-Inspect all electrical wiring, both field- and factory installed, for loose connections. Tighten as required.
- 3-Check to ensure that refrigerant lines do not rub against the cabinet or against other refrigerant lines.
- 4-Check voltage at disconnect switch. Voltage must be within range listed on nameplate. If not, consult power company and have voltage condition corrected before starting unit.
- 5-Make sure filters are new and in place before start-up.

### B-Blower Access

1. Disconnect jack/plug connector to blower motor. Also disconnect jack/plug connector heating limit switches on gas units.
2. Remove screws on either side of blower assembly sliding base. See figure 9.
3. Pull base toward outside of unit.

### C-Determining Unit CFM

**IMPORTANT** - Multi-staged supply air units are factory-set to run the blower at full speed when there is a blower (G) demand without a heating or cooling demand. Refer to the field-provided, design specified CFM for all modes of operation. Use the following procedure to adjust motor pulley to deliver the highest CFM called for in the design spec. See Inverter Start-Up section to set blower CFM for all modes once the motor pulley is set.

- 1 - The following measurements must be made with a dry indoor coil. Run blower (G demand) without a cooling demand. Measure the indoor blower shaft RPM. Air filters must be in place when measurements are taken.

**Note** - Static pressure readings can vary if not taken where shown.

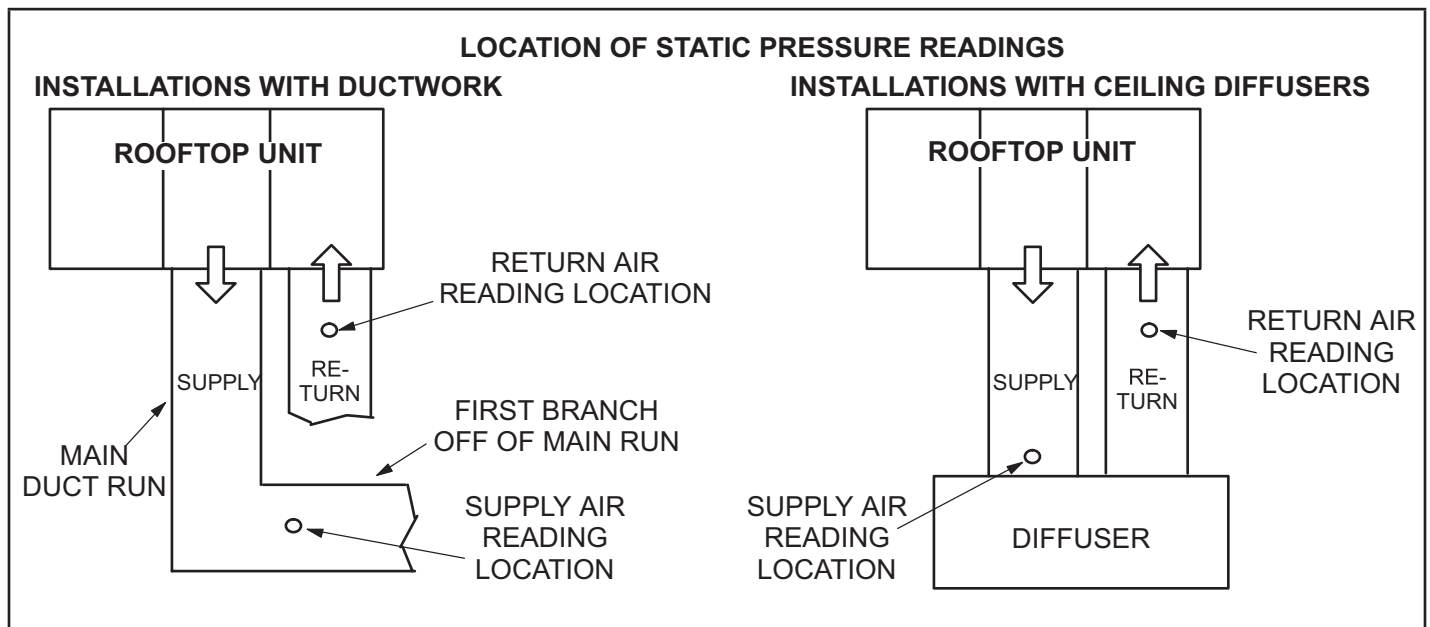
- 2 - With all access panels in place, measure static pressure external to unit (from supply to return). Blower performance data is based on static pressure readings taken in locations shown in figure 8.
- 3 - Accessories. Use static pressure and RPM readings to determine unit CFM.
- 4 - The blower RPM can be adjusted at the motor pulley. Loosen Allen screw and turn adjustable pulley clockwise to increase CFM. Turn counterclockwise to decrease CFM. See figure 9. Do not exceed minimum and maximum number of pulley turns as in table 5.

**TABLE 5**

**MINIMUM AND MAXIMUM PULLEY ADJUSTMENT**

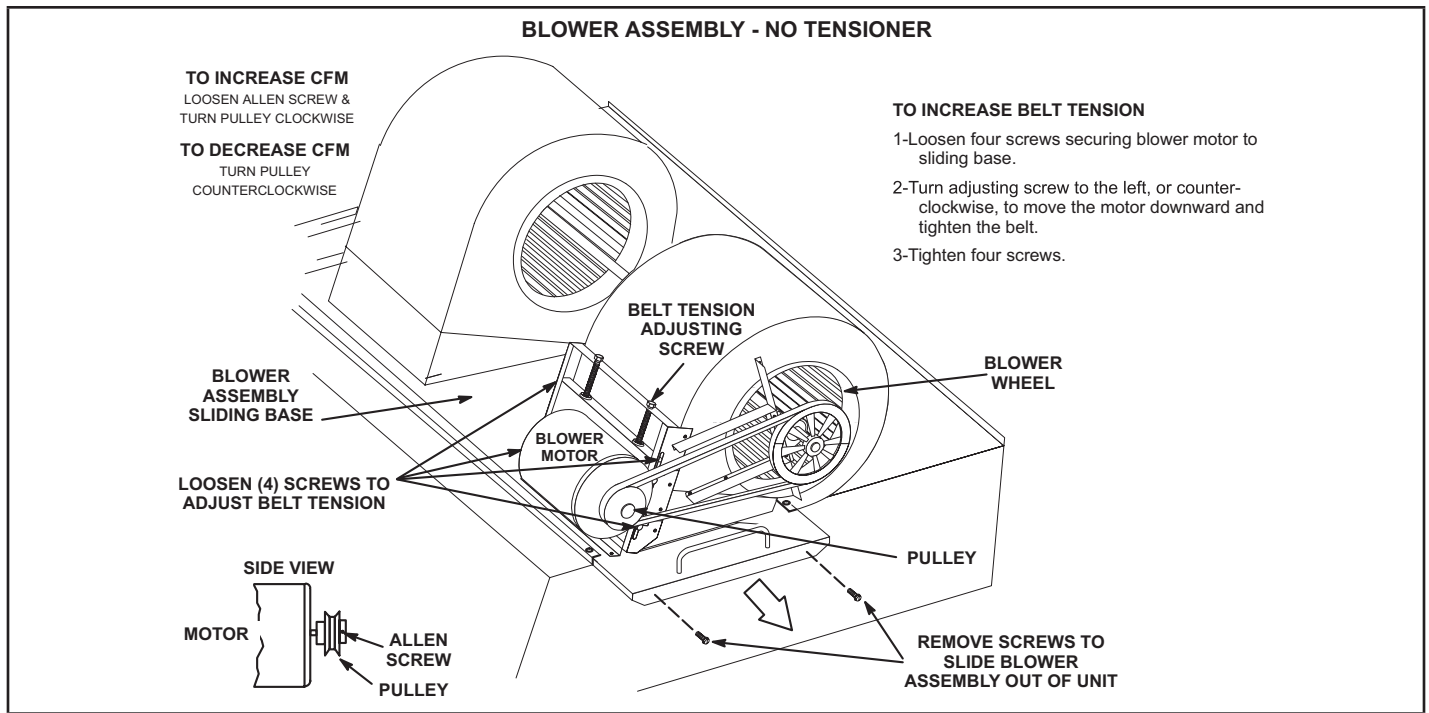
Belt	Min Turns Open	Max Turns Open
A Section	No Min	5
B Section	1*	6

\*No minimum number of turns open when B belt is used on pulleys 6" O.D. or larger.



**FIGURE 8**





**FIGURE 9**

**D-Blower Belt Adjustment**

Maximum life and wear can be obtained from belts only if proper pulley alignment and belt tension are maintained. Tension new belts after a 24-48 hour period of operation. This will allow belt to stretch and seat into pulley grooves. Make sure blower and motor pulley are aligned. See figure 10 for blowers not equipped with a tensioner and figure 11 for units equipped with an optional belt tensioner.

**Blowers Without Belt Tensioner**

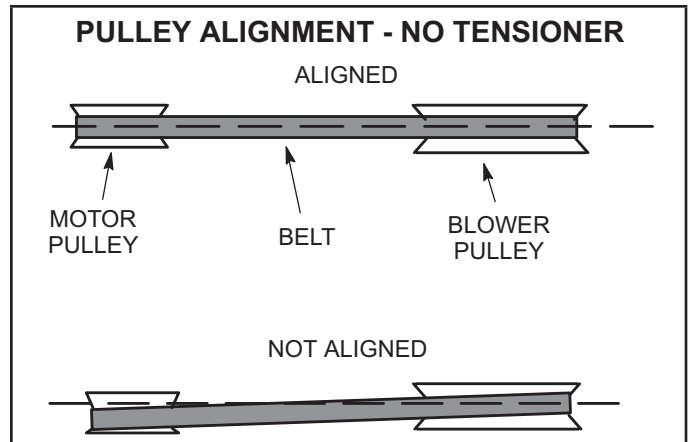
- 1 - Loosen four screws securing blower motor to sliding base. See figure 9.
- 2 - *To increase belt tension -*

Turn belt tension adjusting screw to the left, or counterclockwise, to tighten the belt. This increases the distance between the blower motor and the blower housing.

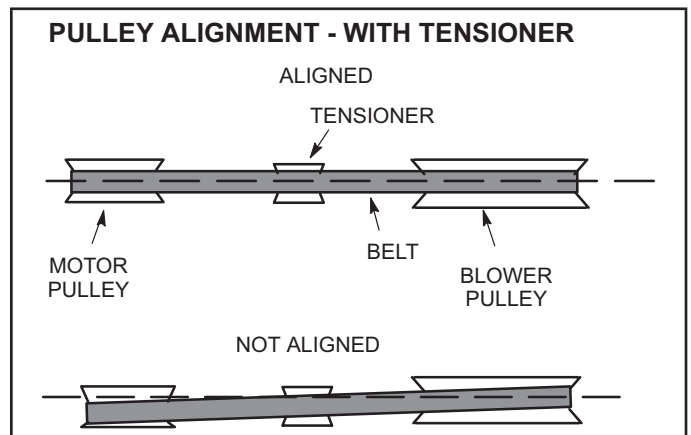
*To loosen belt tension -*

Turn the adjusting screw to the right, or clockwise to loosen belt tension.

- 3 - Tighten four screws securing blower motor to sliding base once adjustments have been made.



**FIGURE 10**



**FIGURE 11**



### PULLEY ALIGNMENT - WITH TENSIONER

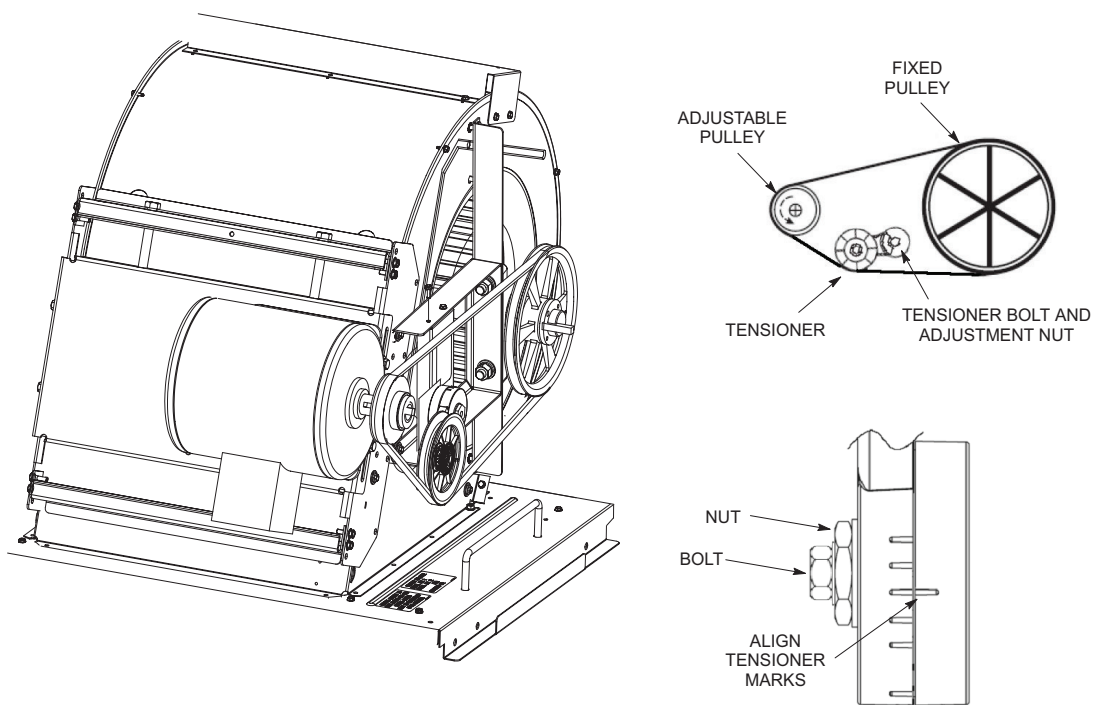


FIGURE 12

#### Blowers Equipped With Belt Tensioner

- 1 - Loosen the bolt in the center of the tensioner. See figure 12.
- 2 - Place belt over all three pulleys.
- 3 - Using a 15/16" wrench, turn the tensioner nut until marks align as shown in figure 12.
- 4 - Hold the tensioner with marks aligned and tighten the bolt to 23 ft.lbs. using the 9/16" wrench.

#### E-Check Belt Tension

Overtensioning belts shortens belt and bearing life. Check belt tension as follows:

- 1 - Measure span length X. See figure 13.
- 2 - Apply perpendicular force to center of span (X) with enough pressure to deflect belt 1/64" for every inch of span length or 1.5mm per 100mm of span length.

Example: Deflection distance of a 40" span would be 40/64" or 5/8".

Example: Deflection distance of a 400mm span would be 6mm.

- 3 - Measure belt deflection force. For a used belt, the deflection force should be 5 lbs. (35kPa) . A new belt deflection force should be 7 lbs. (48kPa).

A force below these values indicates and undertensioned belt. A force above these values indicates an overtensioned belt.

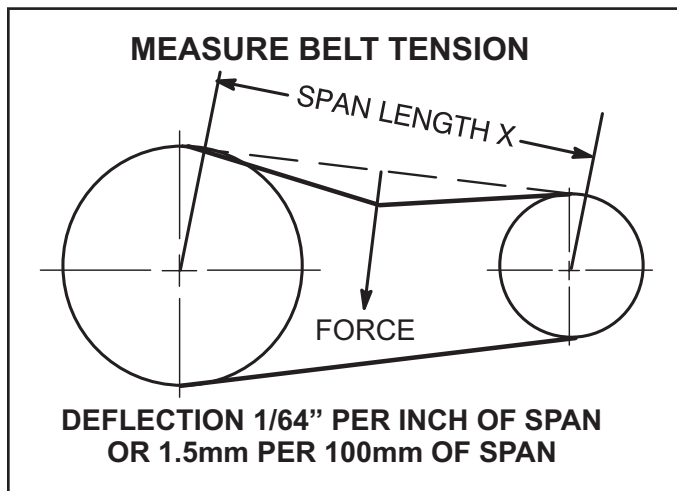


FIGURE 13

## D- OPTIONAL ELECTRIC HEAT

See ELECTRICAL / ELECTRIC HEAT DATA and ELECTRIC HEAT CAPACITIES (table of contents) for LCH to EHA match-ups and electrical ratings.

EHA parts arrangement is shown in figures 15 and 16. All electric heat sections consist of electric heating elements exposed directly to the air stream. Two electric heat sections (first section and second section) are used in all 15kW through 90kW heaters. See figure 14. Multiple stage elements are sequenced on and off in response to thermostat demand.

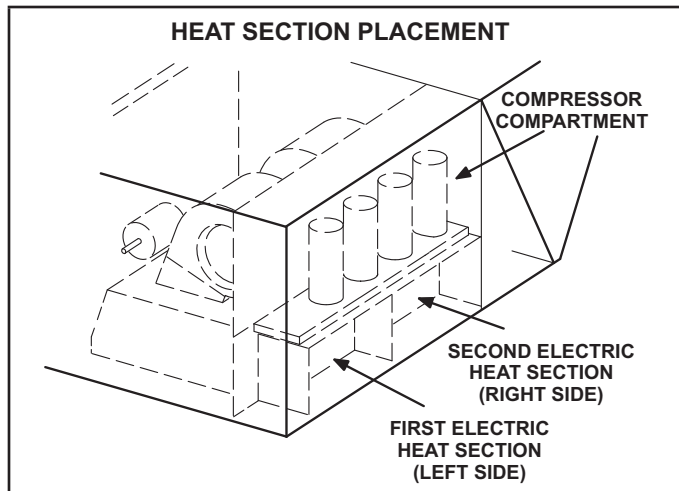


FIGURE 14

### 1-Main Control Box Components A55, K9

The main control box (see figure 3) houses the A55 Unit Controller and the K9 electric heat relay.

### 2-Contactors K15, K16, K17 and K18

Contactors K15, K16, K17 and K18 are all three-pole double-break contactors located on the electric heat vestibule. K15 and K16 are located on the first electric heat section, while K17 and K18 are located on the second electric heat section. However, in the 15 and 30kW heaters, the first section houses all contactors and fuses.

All contactors are equipped with a 24VAC coil. The coils in the K15, K16, K17 and K18 contactors are energized by the main panel A55. Contactors K15 and K17 energize the first stage heating elements, while K16 and K18 energize the second stage heating elements.

### 3-High Temperature Limits S15 and S107 (Primary)

S15 and S107 are SPST N.C. auto-reset thermostats located on the back panel of the electric heat section below the heating elements. S15 is the high temperature limit for the first electric heat section, while S107 is the high temperature limit for the second electric heat section. Both thermostats are identical and are wired to the A55 Unit Controller. When either S15 or S107 opens, indicating a problem in the system, contactor K15 is de-energized. When K15 is de-energized, first stage and all subsequent stages of heat are de-energized.

The thermostats used on EHA360-45-1 Y/G/J are factory set to open at  $200\text{F} \pm 5\text{F}$  ( $93.3\text{C} \pm 2.8\text{C}$ ) on a temperature rise and automatically reset at  $160\text{F} \pm 6\text{F}$  ( $71.1\text{C} \pm 3.3\text{C}$ ) on a temperature fall. All other electric heat section thermostats are factory set to open at  $170\text{F} \pm 5\text{F}$  ( $76.7\text{C} \pm 2.8\text{C}$ ) on a temperature rise and automatically reset at  $130\text{F} \pm 6\text{F}$  ( $54.4\text{C} \pm 3.3\text{C}$ ) on a temperature fall. The thermostats are not adjustable.

### 4-Terminal Strip TB3

Electric heat line voltage connections are made to terminal strip TB3 (or a fuse block on some models) located in the upper left corner of the electric heat vestibule.

### 5-Heating Elements HE1 through HE14

Heating elements are composed of helix wound bare nichrome wire exposed directly to the air stream. Three elements are connected in a three-phase arrangement. The elements in 208/230V units are connected in a "Delta" arrangement. Elements in 460 and 575V units are connected in "Wye" arrangement. Each stage is energized independently by the corresponding contactors located on the electric heat vestibule panel. Once energized, heat transfer is instantaneous. High temperature protection is provided by primary and redundant high temperature limits and overcurrent protection is provided by fuses.

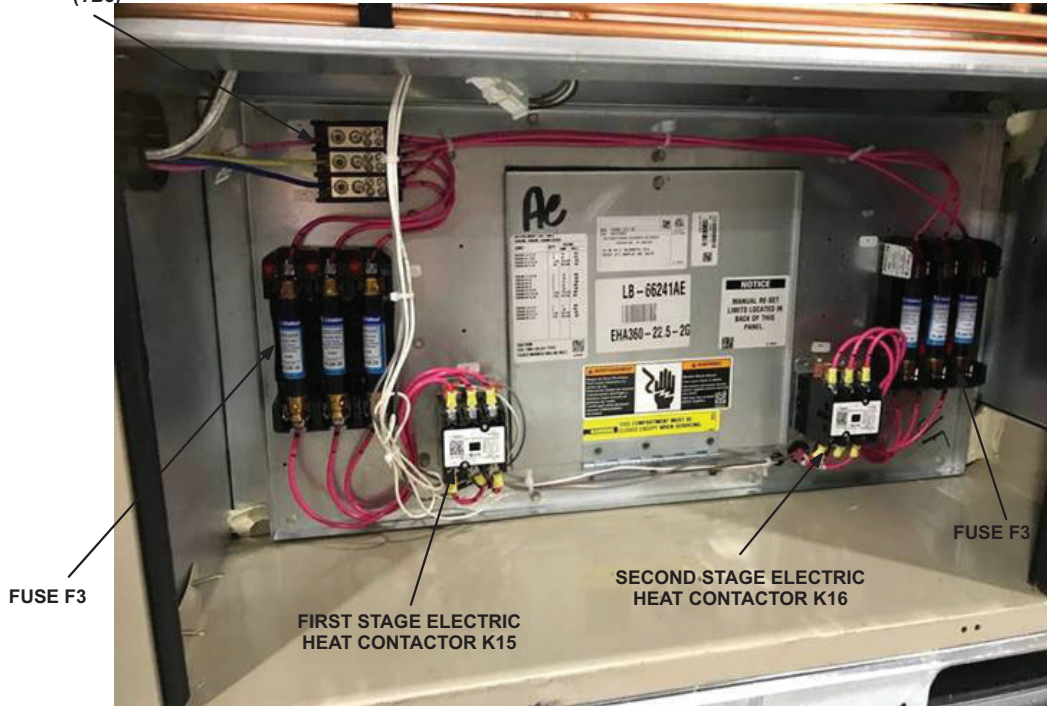
### 6-Fuse F3

Fuse F3 are housed in a fuse block which holds three fuses. Each F3 fuse is connected in series with each leg of electric heat. Figures 15 and 16 and table 6 shows the fuses used with each electric heat section. For simplicity, the service manual labels the fuses F3 - 1 through F3 - 8.

# ELECTRIC HEAT VESTIBULE PARTS ARRANGEMENT

TERMINAL STRIP (TB3)

## FIRST HEAT SECTION (LEFT SIDE)



## SECOND HEAT SECTION (RIGHT SIDE)

TERMINAL STRIP (TB3)

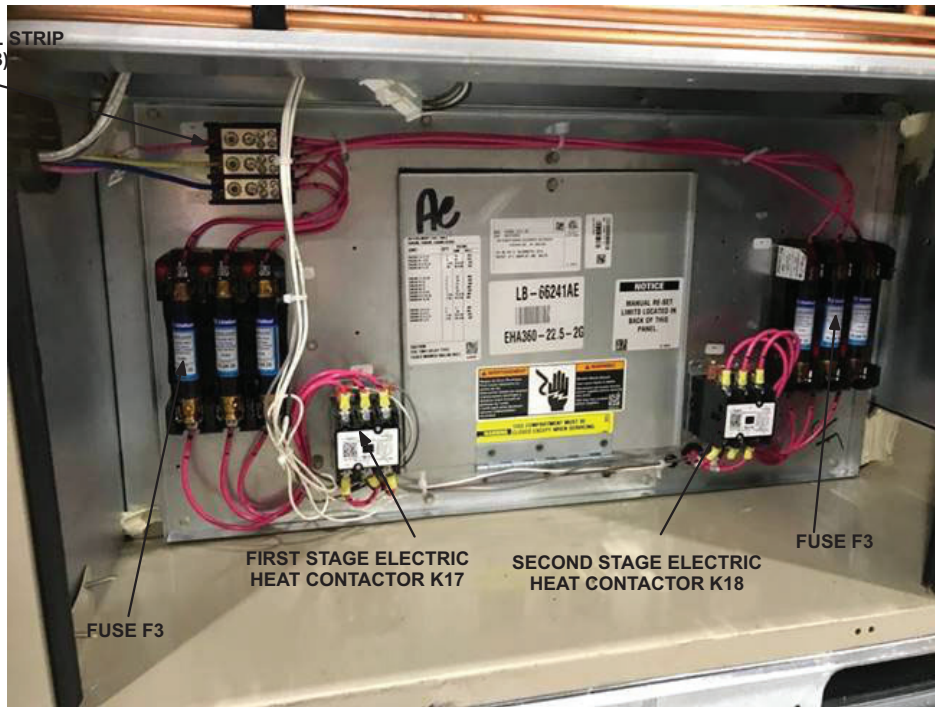
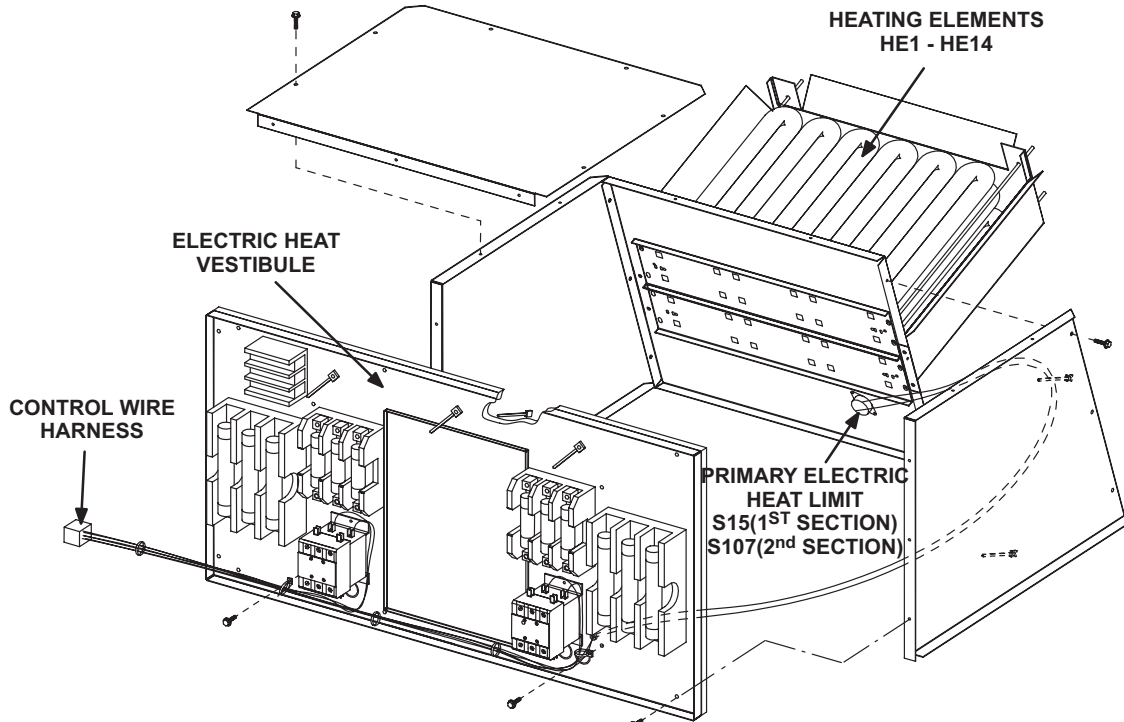


FIGURE 15

## EHA 15, 30, 45, 60 and 90 KW ELECTRIC HEAT SECTION PARTS ARRANGEMENT



**FIGURE 16**

**TABLE 6**

ELECTRIC HEAT SECTION FUSE RATING									
EHA QUANTITY & SIZE	VOLTAGES	FUSE (3 each)							
		F3 - 1	F3 - 2	F3 - 3	F3 - 4	F3 - 5	F3 - 6	F3 - 7	F3 - 8
(1) EHA240-7.5 & (1) EHA240S-7.5 (15 kW Total)	208/230V	50 Amp 250V	---	---	---	---	---	---	---
	460V	25 Amp 600V	---	---	---	---	---	---	---
	575V	20 Amp 600V	---	---	---	---	---	---	---
(1) EHA360-15 & (1) EHA360S-15 (30 kW Total) or (1) EHA156-15 & (1) EHA156S-15	208/230V	60 Amp 250V	60 Amp 250V	---	---	---	---	---	---
	460V	50 Amp 600V	---	---	---	---	---	---	---
	575V	40 Amp 600V	---	---	---	---	---	---	---
(2) EHA360-22.5 (45 kW Total) or (2) EHA156-22.5	208/230V	50 Amp 250V	---	---	25 Amp 250V	50 Amp 250V	---	---	25 Amp 250V
	460V	25 Amp 600V	---	---	15 Amp 600V	25 Amp 600V	---	---	15 Amp 600V
	575V	20 Amp 600V	---	---	10 Amp 600V	20 Amp 600V	---	---	10 Amp 600V
(2) EHA150-30 (60 kW Total) or (2) EHA156-30	208/230V	50 Amp 250V	---	---	50 Amp 250V	50 Amp 250V	---	---	50 Amp 250V
	460V	25 Amp 600V	---	---	25 Amp 600V	25 Amp 600V	---	---	25 Amp 600V
	575V	20 Amp 600V	---	---	20 Amp 600V	20 Amp 600V	---	---	20 Amp 600V
(2) EHA360-45 (90 kW Total)	208/230V	50 Amp 250V	---	60 Amp 250V	60 Amp 250V	50 Amp 250V	---	60 Amp 250V	60 Amp 250V
	460V	25 Amp 600V	---	---	50 Amp 600V	25 Amp 600V	---	---	50 Amp 600V
	575V	20 Amp 600V	---	---	40 Amp 600V	20 Amp 600V	---	---	40 Amp 600V



## II-CHARGING

### A-Refrigerant Charge and Check - Fin/Tube Coil

**NOTE-** Do not exceed nameplate charge under any condition.

This unit is factory charged and should require no further adjustment. If the system requires additional refrigerant, reclaim the charge, evacuate the system and add required nameplate charge.

**NOTE -** System charging is not recommended below 60°F (15°C). In temperatures below 60°F (15°C), the charge must be weighed into the system. If weighing facilities are not available, or to check the charge, use the following procedure:

#### IMPORTANT - Charge unit in normal cooling mode.

- 1 - Attach gauge manifolds to discharge and suction lines. With the economizer disabled, operate the unit in cooling mode at high speed using the following mobile service app (the QR code is in the unit control area) menu path:  
SERVICE>TEST>COOL>COOL 4
- 2 - Use a thermometer to accurately measure the outdoor ambient temperature.
- 3 - Apply the outdoor temperature to tables 7 through 16 to determine normal operating pressures. Pressures are listed for sea level applications at 80°F dry bulb and 67°F wet bulb return air.
- 4 - Compare the normal operating pressures to the pressures obtained from the gauges. Minor variations in these pressures may be expected due to differences in installations. Significant differences could mean that the system is not properly charged or that a problem exists with some component in the system. Correct any system problems before proceeding.
- 5 - If discharge pressure is high, remove refrigerant from the system. If discharge pressure is low, add refrigerant to the system.
  - Add or remove charge in increments.
  - Allow the system to stabilize each time refrigerant is added or removed.
- 6 - Use the following approach method along with the normal operating pressures to confirm readings.

**TABLE 7**

156 Std. Compressor 1 Frequency 56Hz - 581014-01

Outdoor Coil Entering Air Temp	Circuit 1		Circuit 2		Circuit 3	
	Dis. ±10 psig	Suc. ±5 psig	Dis. ±10 psig	Suc. ±5 psig	Dis. ±10 psig	Suc. ±5 psig
65°F	228	127	256	131	258	140
75°F	267	130	295	134	298	148
85°F	309	133	337	136	340	153
95°F	352	135	383	139	387	156
105°F	403	139	432	142	433	159
115°F	457	142	485	145	486	162

**TABLE 8**

156 Reheat Compressor 1 Frequency 56Hz - 581015-01

Outdoor Coil Entering Air Temp	Circuit 1		Circuit 2		Circuit 3	
	Dis. ±10 psig	Suc. ±5 psig	Dis. ±10 psig	Suc. ±5 psig	Dis. ±10 psig	Suc. ±5 psig
65°F	230	123	274	127	260	140
75°F	267	126	313	129	299	144
85°F	309	129	353	132	341	147
95°F	355	133	398	135	385	150
105°F	404	135	447	137	432	153
115°F	463	139	507	140	485	156

**TABLE 9**

180 Std. Compressor 1 Frequency 56Hz - 581016-01

Outdoor Coil Entering Air Temp	Circuit 1		Circuit 2		Circuit 3	
	Dis. ±10 psig	Suc. ±5 psig	Dis. ±10 psig	Suc. ±5 psig	Dis. ±10 psig	Suc. ±5 psig
65°F	232	123	276	131	279	141
75°F	267	129	313	133	315	147
85°F	311	132	360	136	362	151
95°F	357	135	406	138	408	154
105°F	403	137	456	141	455	158
115°F	456	140	511	144	510	161

**TABLE 10**

180 Reheat Compressor 1 Frequency 56Hz - 581017-01

Outdoor Coil Entering Air Temp	Circuit 1		Circuit 2		Circuit 3	
	Dis. ±10 psig	Suc. ±5 psig	Dis. ±10 psig	Suc. ±5 psig	Dis. ±10 psig	Suc. ±5 psig
65°F	233	122	291	129	267	132
75°F	270	127	330	131	307	138
85°F	313	129	373	133	348	143
95°F	360	134	430	137	398	147
105°F	411	136	472	139	441	149
115°F	469	139	531	142	495	152

**TABLE 11**

210 Std. Compressor 1 Frequency 48Hz - 581018-01

Outdoor Coil Entering Air Temp	Circuit 1		Circuit 2		Circuit 3		Circuit 4	
	Dis. ±10 psig	Suc. ±5 psig	Dis. ±10 psig	Suc. ±5 psig	Dis. ±10 psig	Suc. ±5 psig	Dis. ±10 psig	Suc. ±5 psig
65°F	245	125	255	127	253	139	259	140
75°F	283	127	294	130	290	143	299	146
85°F	323	129	336	133	330	146	343	149
95°F	368	131	386	136	376	148	393	151
105°F	418	134	435	139	425	152	440	153
115°F	472	137	489	142	479	154	496	155

**TABLE 12**

**210 Reheat Compressor 1 Frequency 48Hz - 581019-01**

Outdoor Coil Entering Air Temp	Circuit 1		Circuit 2		Circuit 3		Circuit 4	
	Dis. $\pm 10$ psig	Suc. $\pm 5$ psig	Dis. $\pm 10$ psig	Suc. $\pm 5$ psig	Dis. $\pm 10$ psig	Suc. $\pm 5$ psig	Dis. $\pm 10$ psig	Suc. $\pm 5$ psig
65°F	245	127	267	126	241	120	264	141
75°F	279	130	303	129	279	129	301	146
85°F	317	133	344	132	318	136	342	149
95°F	367	136	393	134	365	143	391	152
105°F	407	139	438	138	409	147	438	155
115°F	461	143	492	141	462	151	493	159

**TABLE 13**

**240 Std. Compressor 1 Frequency 62Hz - 581020-01**

Outdoor Coil Entering Air Temp	Circuit 1		Circuit 2		Circuit 3		Circuit 4	
	Dis. $\pm 10$ psig	Suc. $\pm 5$ psig	Dis. $\pm 10$ psig	Suc. $\pm 5$ psig	Dis. $\pm 10$ psig	Suc. $\pm 5$ psig	Dis. $\pm 10$ psig	Suc. $\pm 5$ psig
65°F	250	117	261	124	252	129	267	139
75°F	289	121	301	128	292	136	310	146
85°F	331	124	348	131	334	140	355	151
95°F	374	126	393	134	379	142	400	154
105°F	425	130	450	138	430	145	456	158
115°F	481	133	507	141	484	148	514	161

**TABLE 14**

**240 Reheat Compressor 1 Frequency 62Hz - 581021-01**

Outdoor Coil Entering Air Temp	Circuit 1		Circuit 2		Circuit 3		Circuit 4	
	Dis. $\pm 10$ psig	Suc. $\pm 5$ psig	Dis. $\pm 10$ psig	Suc. $\pm 5$ psig	Dis. $\pm 10$ psig	Suc. $\pm 5$ psig	Dis. $\pm 10$ psig	Suc. $\pm 5$ psig
65°F	263	122	296	126	239	126	273	140
75°F	304	126	336	126	276	133	312	144
85°F	348	129	384	128	318	138	357	148
95°F	387	129	405	129	373	140	389	148
105°F	442	133	464	133	424	144	440	151
115°F	500	137	523	136	477	147	497	152

**TABLE 15**

**300 Std. Compressor 1 Frequency 68Hz - 581022-01**

Outdoor Coil Entering Air Temp	Circuit 1		Circuit 2		Circuit 3		Circuit 4	
	Dis. $\pm 10$ psig	Suc. $\pm 5$ psig	Dis. $\pm 10$ psig	Suc. $\pm 5$ psig	Dis. $\pm 10$ psig	Suc. $\pm 5$ psig	Dis. $\pm 10$ psig	Suc. $\pm 5$ psig
65°F	260	115	260	118	272	117	269	119
75°F	301	118	304	124	316	126	314	130
85°F	345	121	350	127	362	133	360	138
95°F	387	126	407	130	403	138	412	145
105°F	437	128	460	134	455	141	466	149
115°F	490	131	519	137	510	144	522	154

**TABLE 16**

**300 Reheat Compressor 1 Frequency 68Hz - 581023-01**

Outdoor Coil Entering Air Temp	Circuit 1		Circuit 2		Circuit 3		Circuit 4	
	Dis. $\pm 10$ psig	Suc. $\pm 5$ psig	Dis. $\pm 10$ psig	Suc. $\pm 5$ psig	Dis. $\pm 10$ psig	Suc. $\pm 5$ psig	Dis. $\pm 10$ psig	Suc. $\pm 5$ psig
65°F	274	121	295	120	259	114	275	120
75°F	316	124	339	122	301	123	317	128
85°F	363	126	387	124	346	131	362	135
95°F	415	129	442	127	395	137	414	141
105°F	469	132	497	130	447	142	464	144
115°F	525	136	558	133	502	145	519	147

**B-Charge Verification - Approach Method - AHRI Testing (Fin/Tube Coil)**

- Using the same thermometer, compare liquid temperature to outdoor ambient temperature.  
Approach Temperature = Liquid temperature (at condenser outlet) minus ambient temperature.
- Approach temperature should match values in table 17. An approach temperature greater than value shown indicates an undercharge. An approach temperature less than value shown indicates an overcharge.
- The approach method is not valid for grossly over or undercharged systems. Use tables 7 through 16 as a guide for typical operating pressures.

**TABLE 17**

**APPROACH TEMPERATURES - FIN/TUBE COIL**

Unit	Liquid Temp. Minus Ambient Temp.			
	1st Stage	2nd Stage	3rd Stage	4th Stage
156 Std.	3.0°F $\pm 1$ (1.7°C $\pm 0.5$ )	6.0°F $\pm 1$ (3.3°C $\pm 0.5$ )	6.5°F $\pm 1$ (3.6°C $\pm 0.5$ )	NA
156 Reheat	1.7°F $\pm 1$ (0.9°C $\pm 0.5$ )	1.7°F $\pm 1$ (0.9°C $\pm 0.5$ )	2.7°F $\pm 1$ (1.5°C $\pm 0.5$ )	NA
180 Std.	2.5°F $\pm 1$ (1.4°C $\pm 0.5$ )	5.0°F $\pm 1$ (2.8°C $\pm 0.5$ )	5.5°F $\pm 1$ (3.1°C $\pm 0.5$ )	NA
180 Reheat	1.0°F $\pm 1$ (0.6°C $\pm 0.5$ )	2.8°F $\pm 1$ (1.6°C $\pm 0.5$ )	4.8°F $\pm 1$ (2.7°C $\pm 0.5$ )	NA
210 Std.	1.0°F $\pm 1$ (0.6°C $\pm 0.5$ )	5.5°F $\pm 1$ (3.1°C $\pm 0.5$ )	3.0°F $\pm 1$ (1.7°C $\pm 0.5$ )	6.0°F $\pm 1$ (3.3°C $\pm 0.5$ )
210 Reheat	2.5°F $\pm 1$ (1.4°C $\pm 0.5$ )	3.7°F $\pm 1$ (2.1°C $\pm 0.5$ )	6.0°F $\pm 1$ (3.3°C $\pm 0.5$ )	4.3°F $\pm 1$ (2.4°C $\pm 0.5$ )
240 Std.	3.5°F $\pm 1$ (1.9°C $\pm 0.5$ )	8.3°F $\pm 1$ (4.6°C $\pm 0.5$ )	4.7°F $\pm 1$ (2.6°C $\pm 0.5$ )	7.5°F $\pm 1$ (4.2°C $\pm 0.5$ )
240 Reheat	1.9°F $\pm 1$ (1.1°C $\pm 0.5$ )	3.8°F $\pm 1$ (2.1°C $\pm 0.5$ )	2.2°F $\pm 1$ (1.2°C $\pm 0.5$ )	5.4°F $\pm 1$ (3.0°C $\pm 0.5$ )
300 Std.	1.5°F $\pm 1$ (0.8°C $\pm 0.5$ )	5.5°F $\pm 1$ (3.1°C $\pm 0.5$ )	4.0°F $\pm 1$ (2.2°C $\pm 0.5$ )	6.5°F $\pm 1$ (3.6°C $\pm 0.5$ )
300 Reheat	2.8°F $\pm 1$ (1.5°C $\pm 0.5$ )	4.2°F $\pm 1$ (2.3°C $\pm 0.5$ )	3.8°F $\pm 1$ (2.1°C $\pm 0.5$ )	5.4°F $\pm 1$ (3.0°C $\pm 0.5$ )



### III-STARTUP - OPERATION

Refer to startup directions and to the unit wiring diagram when servicing. See unit nameplate for minimum circuit ampacity and maximum fuse size.

#### A-Cooling Startup See figure 7 for unit refrigerant circuits

NOTE-Crankcase heaters must be energized 24 hours before attempting to start compressor. Set thermostat so that there is no demand to prevent compressor from cycling. Apply power to unit.

Apply power to unit.

- 1 - Initiate first and second stage cooling demands according to instructions provided with thermostat.
- 2 - First-stage thermostat demand will energize indoor blower in Low Cooling CFM. Second-stage thermostat demand will energize indoor blower in High Cooling CFM. Both demands energize compressor 1 (variable speed compressor). The remaining compressors will be energized to modulate the discharge air temperature.
- 3 - *156, 180-*  
Units contain three refrigerant circuits or systems.  
*210, 240, 300 -*  
Units contain four refrigerant circuits or systems.
- 4 - Each refrigerant circuit is separately charged with R410A refrigerant. See unit rating plate for correct amount of charge.
- 5 - Refer to the Refrigerant Check and Charge section to check refrigerant charge.

### IV- SYSTEMS SERVICE CHECKS



#### A-Preliminary and Seasonal Checks

- 1 - Make sure the unit is installed in accordance with the installation instructions and applicable codes.
- 2 - Inspect all electrical wiring, both field and factory installed for loose connections. Tighten as required. Refer to unit diagram located on inside of unit control box cover.
- 3 - Check to ensure that refrigerant lines are in good condition and do not rub against the cabinet or other refrigerant lines.
- 4 - Check voltage. Voltage must be within the range listed on the nameplate. If not, consult power company and have the voltage corrected before starting the unit.
- 5 - Recheck voltage and amp draw with unit running. If voltage is not within range listed on unit nameplate, stop unit and consult power company. Refer to unit nameplate for maximum rated load amps.
- 6 - Inspect and adjust blower belt (see section on Blower Compartment - Blower Belt Adjustment).

### B-Cooling System Service Checks

LCM units are factory charged and require no further adjustment; however, charge should be checked periodically using the approach method. The approach method compares actual liquid temperature with the outdoor ambient temperature. See section II- CHARGING.

### V-MAINTENANCE

 <b>WARNING</b>	
	<b>Electric shock hazard. Can cause injury or death. Before attempting to perform any service or maintenance, turn the electrical power to unit OFF at disconnect switch(es). Unit may have multiple power supplies.</b>

#### A-Filters

LCM units use six 24 X 24 X 2" fiberglass throw-away type filters. Filters may be accessed through the economizer / filter access door. Filters should be checked monthly (or more frequently in severe use) and cleaned or replaced regularly. Take note of the "AIR FLOW DIRECTION" marking on the filter frame when re-installing.

#### B-Lubrication

All motors and blower wheels used in LCM units are lubricated; no further lubrication is required.

#### C-Supply Air Blower Wheel

Annually inspect supply air blower wheel for accumulated dirt or dust. Turn off power before attempting to remove access panel or to clean blower wheel.

#### D-Evaporator Coil

Inspect and clean coil at beginning of each season. Clean using mild detergent or commercial coil cleanser. Check condensate drain pan and line, if necessary. Flush coil and condensate drain with water taking care not to get insulation, filters and return air ducts wet. Check connecting lines and coil for evidence of oil and refrigerant leaks.

#### E-Condenser Coil

Clean condenser coil annually with detergent or commercial coil cleaner and inspect monthly during the cooling season. Check connecting lines and coil for evidence of oil and refrigerant leaks.

#### F-Electrical

- 1 - Check all wiring for loose connections.
- 2 - Check for correct voltage at unit (unit operating).
- 3 - Check amp-draw on both condenser fan motor and blower motor.

Fan Motor Rating Plate \_\_\_\_ Actual \_\_\_\_\_

Indoor Blower Motor Rating Plate \_\_\_\_ Actual \_\_\_\_\_

## VI-ACCESSORIES

The accessories section describes the application of most of the optional accessories which can be factory or field installed to the LCM units.

### A-Roof Curbs

When installing the LCM units on a combustible surface for downflow discharge applications, the hybrid C1CUR-B70C-1 8-in height, C1CURB71C-1 14-in height, C1CUR-B72C-01 18-in height and C1CURB73C-1 24-in roof mounting frame is used. The assembled hybrid mounting frame is shown in figure 17. Refer to the roof mounting frame installation instructions for details of proper assembly and mounting. The roof mounting frame MUST be squared to the roof and level before mounting. Plenum system MUST be installed before the unit is set on the mounting frame. Typical roof curbing and flashing is shown in figure 18. Refer to the roof mounting frame installation instructions for proper plenum construction and attachment. For horizontal discharge applications, use the standard C1URB14C-1 26-in or C1CURB16C-1 37-in height roof mounting frame. This frame converts unit from down-flow to horizontal air flow. The 37 inch horizontal frame meets National Roofing Code requirements. The roof mounting frames are recommended in all other applications but not required. If the LCM units are not mounted on a flat (roof) surface, they MUST be supported under all edges and under the middle of the unit to prevent sagging. The units MUST be mounted level within 1/16" per linear foot or 5mm per meter in any direction.

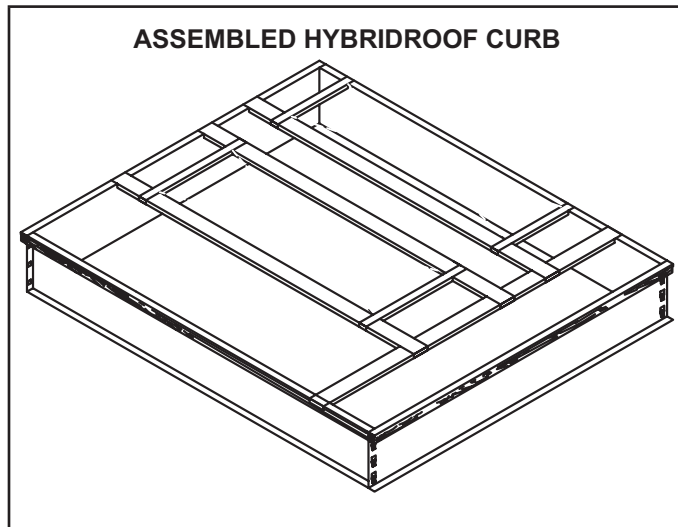


FIGURE 17

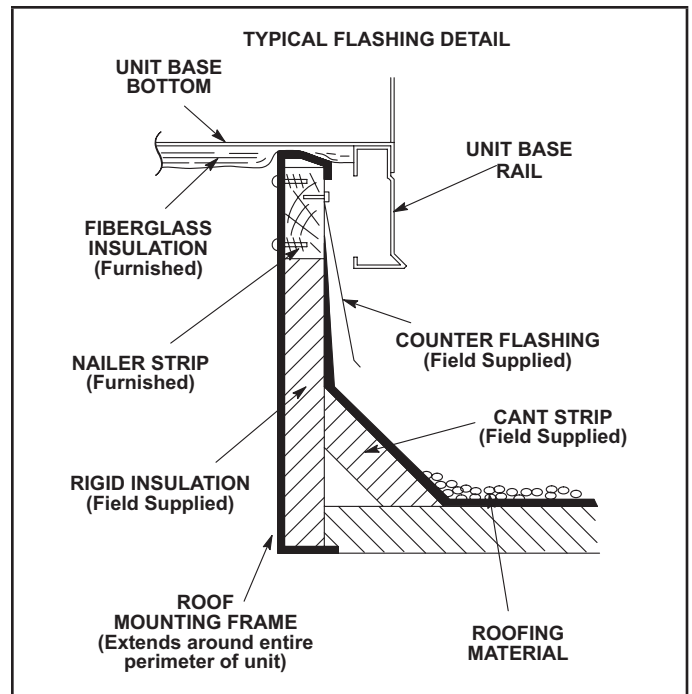


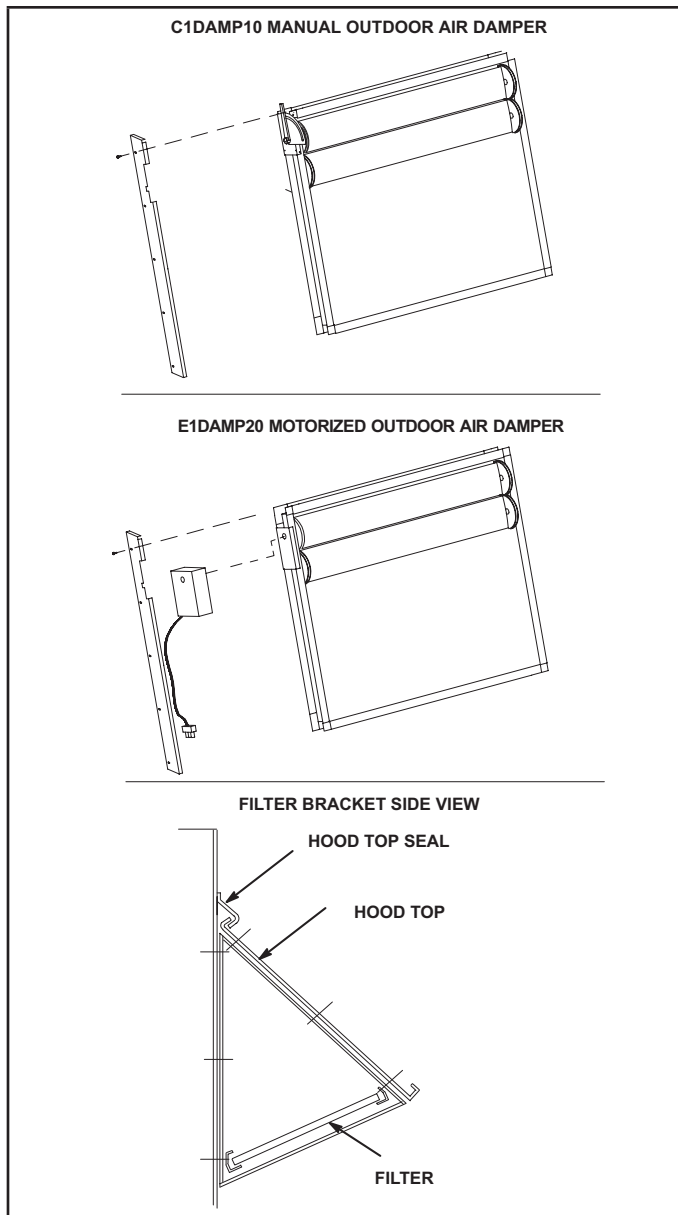
FIGURE 18

### B-Transitions

Optional supply/return transitions C1DIFF33C-1 and C1DIFF34C-1 are available for use with LCM series units utilizing optional C1CURB roof curbs. Transition must be installed in the roof curb before mounting the unit to the frame. Refer to the manufacturer's instructions included with the transition for detailed installation procedures.

### C-C1DAMP10 & E1DAMP20 Outdoor Air Dampers

C1DAMP10C and E1DAMP20C (figure 19) consist of a set of dampers which may be manually or motor operated to allow up to 25 percent outside air into the system at all times (see figure 19). Either air damper can be installed in LCM units. Washable filter supplied with the outdoor air dampers can be cleaned with water and a mild detergent. It should be sprayed with Filter Handicoater when dry prior to reinstallation. Filter Handicoater is R.P. Products coating no. 418 and is available as Part No. P-8-5069.



**FIGURE 19**

**D-Supply and Return Diffusers**

Optional flush mount diffuser/return FD11 and extended mount diffuser/return RTD11 are available for use with all LGM units. Refer to manufacturer's instructions included with transition for detailed installation procedures.

**E-E1ECON15C-2 Standard and E1ECON17C-1**

**High Performance Economizer (Field or Factory Installed)**

The optional economizer can be used with downflow and horizontal air discharge applications. The economizer uses outdoor air for free cooling when temperature and/or humidity is suitable. An economizer hood is furnished with the economizer

**NOTE - Gravity exhaust dampers are required with power exhaust.**

The economizer is controlled by the A55 Unit Controller. The economizer will operate in one of four modes. Each mode requires a different A55 Unit Controller DIP switch setting. Each mode also requires different sensors.

The following is a brief description. See economizer installation instruction for more detail.

**1-"TMP" MODE (SENSIBLE TEMPERATURE)**

In the "TMP" mode, the IMC uses input from the factory installed RT6 Supply Air Sensor, RT16 Return Air Sensor and RT17 Outdoor Air Sensor to determine suitability of outside air and economizer damper operation. When outdoor sensible temperature is less than return air sensible temperature, outdoor air is used for cooling. This may be supplemented by mechanical cooling to meet comfort demands. This application does not require additional optional sensors.

**2-"ODE" MODE (OUTDOOR ENTHALPY)**

The "ODE" or outdoor enthalpy mode requires a field-provided and -installed Honeywell C7400 enthalpy sensor (16K96). The sensor monitors outdoor air temperature and humidity (enthalpy). When outdoor air enthalpy is below the enthalpy control setpoint, the economizer modulates to allow outdoor air for free cooling.

**3-"DIF" MODE (DIFFERENTIAL ENTHALPY)**

The "DIF" or differential enthalpy mode requires two field-provided and -installed Honeywell C7400 enthalpy sensors (16K97). One sensor is installed in the outside air opening and the other sensor is installed in the return air opening. When the outdoor air enthalpy is below the return air enthalpy, the economizer opens to bring in outdoor air for free cooling.

**4-"GLO" MODE (GLOBAL)**

**Global Mode -** The "GLO" or global mode is used with an energy management system which includes a global control feature. Global control is used when multiple units (in one location) respond to a single outdoor air sensor. Each energy management system uses a specific type of outdoor sensor which is installed and wired by the controls contractor. **Motorized Outdoor Air Damper -** The "GLO" mode is also used when a motorized outdoor air damper is installed in the system.

**Motorized Outdoor Air Damper -** The "GLO" mode is also used when a motorized outdoor air damper is installed in the system.

**NOTE - All economizer modes of operation will modulate dampers to 55F (13C) supply air.**

## F-Gravity Exhaust Dampers

C1DAMP50C dampers (figure 20) are used in downflow and LAGEDH are used in horizontal air discharge applications. LAGEDH gravity exhaust dampers are installed in the return air plenum. The dampers must be used any time an economizer or power exhaust fans are applied to LGM series units. An exhaust hood is furnished with the gravity exhaust damper.

Gravity exhaust dampers allow exhaust air to be discharged from the system when an economizer and/or power exhaust is operating. Gravity exhaust dampers also prevent outdoor air infiltration during unit off cycle. See installation instructions for more detail.

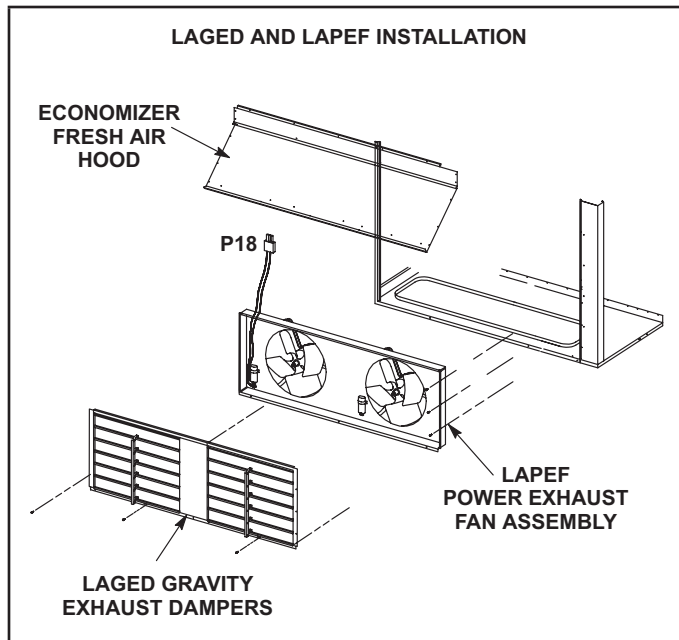


FIGURE 20

## G-C1PWRE10 Power Exhaust Fans

C1PWRE10 power exhaust fans are used in downflow applications only. C1PWRE10 fans require optional downflow gravity exhaust dampers and E1ECON15 economizers. Power exhaust fans provide exhaust air pressure relief and also run when return air dampers are closed and supply air blowers are operating. Figure 20 shows the location of the power exhaust fans. See installation instructions for more detail.

## H-Optional Cold Weather Kit (Canada only)

Electric heater is available to automatically control the minimum temperature in the gas burner compartment. Heater is C.G.A. certified to allow cold weather operation of unit down to -60° F (-50° C).

The kit includes the following parts:

- 1 - The strip heater (HR6) is located as close as possible to the gas valve. The strip heater is rated at 500 Watts (line voltage).
- 2 - A thermostat mounting box is installed on the vestibule of the heating compartment. Included in the box are the following thermostat switches:
  - a. Thermostat switch (S59) is an auto-reset SPST N.C. switch which opens on a temperature drop. The switch is wired in series with 24v power and the combustion air blower switch. When the temperature drops below -30° F (-35° C) the switch opens and the gas heat section is de-energized. The switch automatically resets when the heating compartment temperature reaches -10° F (-12° C).
  - b. Thermostat switch (S60) is an auto-reset SPST N.C. switch which opens on a temperature rise. The switch is wired in series with K125 coil. When the temperature rises above 20° F (-7° C) the switch opens and the electric heater is de-energized through K125. The switch automatically resets when the heating compartment temperature reaches -10° F (23.3° C).
  - c. Thermostat switch (S61) is an auto-reset SPST N.O. switch which closes on a temperature drop. The switch is wired in series with K125 coil. When temperature drops below 20° F (-7° C) the switch closes and electric heater is energized through K125. The switch automatically opens when heating compartment temperature reaches 76° F (24° C).

## **I-Control Systems**

The A55 Unit Controller provides all control function for the rooftop unit. Default operation requires a standard room thermostat or direct digital controller (DDC). The A55 can also control the unit from a zone temperature sensor. The A55 Unit Controller is a network controller when daisy-chained to the L Connection® Network Control System. For ease of configuration, the A55 can be connected to a PC with Unit Controller PC software installed.

### **J-Smoke Detectors A171, A172, A173**

Photoelectric smoke detectors are a factory- and field-installed option. The smoke detectors can be installed in the supply air section (A172), return air section (A171), or in both the supply and return air section. Smoke detection control module (A173) is located below the control panel. Wiring for the smoke detectors are shown on the temperature control section (C) wiring diagram in back of this manual.

### **K-Blower Proving Switch S52**

The blower proving switch monitors blower operation and locks out the unit in case of blower failure. The switch is N.O. and closes at .15" W.C. (3.3 Pa) The switch is mounted on the middle left corner of the blower support panel. Wiring for the blower proving switch is shown on the temperature control section (C) wiring diagram in back of this manual.

### **L-Dirty Filter Switch S27**

The dirty filter switch senses static pressure increase indicating a dirty filter condition. The switch is N.O. and closes at 1" W.C. (248.6 Pa) The switch is mounted on the top corner of the economizer. Wiring for the dirty filter switch is shown on the temperature control section (C) wiring diagram in back of this manual.

## **M-Optional UVC Lights**

The Healthy Climate® germicidal light emits ultraviolet (UVC) energy that has been proven effective in reducing microbial life forms (viruses, bacteria, yeasts and molds) in the air.

UVC germicidal lamps greatly reduce the growth and proliferation of mold and other bio-aerosols (bacteria and viruses) on illuminated surfaces.

Germicidal lamps are NOT intended to be used for removal of active mold growth. Existing mold growth must be appropriately removed PRIOR to installation of the germicidal lamp.

Refer closely to UVC light installation instruction warnings when servicing units.

### **N-Drain Pan Overflow Switch S149 (optional)**

The overflow switch is used to interrupt cooling operation when excessive condensate collects in the drain pan.

The N.C. overflow switch is connected to the M2 Unit Controller (A55) through DI-3. When the switch opens, the Unit Controller will shut off the unit. After a five-minute time out, the Unit Controller will verify the overflow switch position and restart the unit (if the switch has closed). The Unit Controller has a three-strike counter before the unit locks out. This means the Unit Controller will allow the overflow switch to open three times per thermostat demand. If the unit locks out, a reset of the Unit Controller is required after the switch has closed to restore unit operation.



## VII-FACTORY-INSTALLED Hot Gas Re-Heat

### General

Hot gas reheat units provide a dehumidifying mode of operation. These units contain a reheat coil adjacent to and downstream of the evaporator coil. Reheat coil solenoid valves, L14 and L30, route hot discharge gas from the compressor to the reheat coil. Return air pulled across the evaporator coil is cooled and dehumidified; the reheat coil adds heat to supply air. See figure 21 for 156 and 180 reheat refrigerant routing, figure 22 for 156 and 180 normal cooling refrigerant routing, figure 24 for 210, 240, and 300 reheat refrigerant routing and figure 35 for 210, 240, and 300 normal cooling refrigerant routing.

### L14 and L30 Reheat Coil Solenoid Valves

When Unit Controller (P298-5 or J299-8) indicates room conditions require dehumidification, reheat valves L14 and L30 are energized (Unit Controller J394-1 or J394-3) and refrigerant is routed to the reheat coil.

### Reheat Setpoint

Reheat is factory-set to energize when indoor relative humidity rises above 60% (default). The reheat setpoint can be adjusted by changing mobile service app Settings - Control menu. A setting of 100% will operate reheat from an energy management system digital output. The reheat setpoint can also be adjusted using an optional Network Control Panel (NCP). Reheat will terminate when the indoor relative humidity falls 3% (57% default) or the digital output de-energizes. The reheat deadband can be adjusted at *Settings - Control* menu.

### A91 Humidity Sensor

Relative humidity should correspond to the sensor (A91) output voltage listed in table 18. For example: if indoor air relative humidity is 80% + 3%, the humidity sensor output should read 8.00VDC. Check the sensor output annually for accuracy. Keep the air intake openings on the sensor clean and free of obstructions and debris.

TABLE 18

Relative Humidity (%RH $\pm$ 3%)	Sensor Output (VDC)
20	2.00
30	3.00
40	4.00
50	5.00
60	6.00
70	7.00
80	8.00
90	9.00

### Check-Out

Test hot gas reheat operation using the following procedure.

- 1 - Make sure reheat is wired as shown in wiring section.
- 2 - Make sure unit is in local thermostat mode.
- 3 - Use mobile service app (the QR is located in the control area) menu path to select:

SERVICE > TEST > DEHUMIDIFIER

The blower, compressor 1 and compressor 2 (reheat) should be operating. Reheat mode will appear on the mobile service app display.

- 4 - Deselect:

SERVICE > TEST > DEHUMIDIFIER

*Compressor 1 and 2 (reheat) should de-energize, blower should still be energized.*

### Default Reheat Operation

Reheat will operate as shown in table 19 once this condition is met:

- 1 - System must NOT be operating in heating mode.

**IMPORTANT - Free cooling does not operate during reheat.**

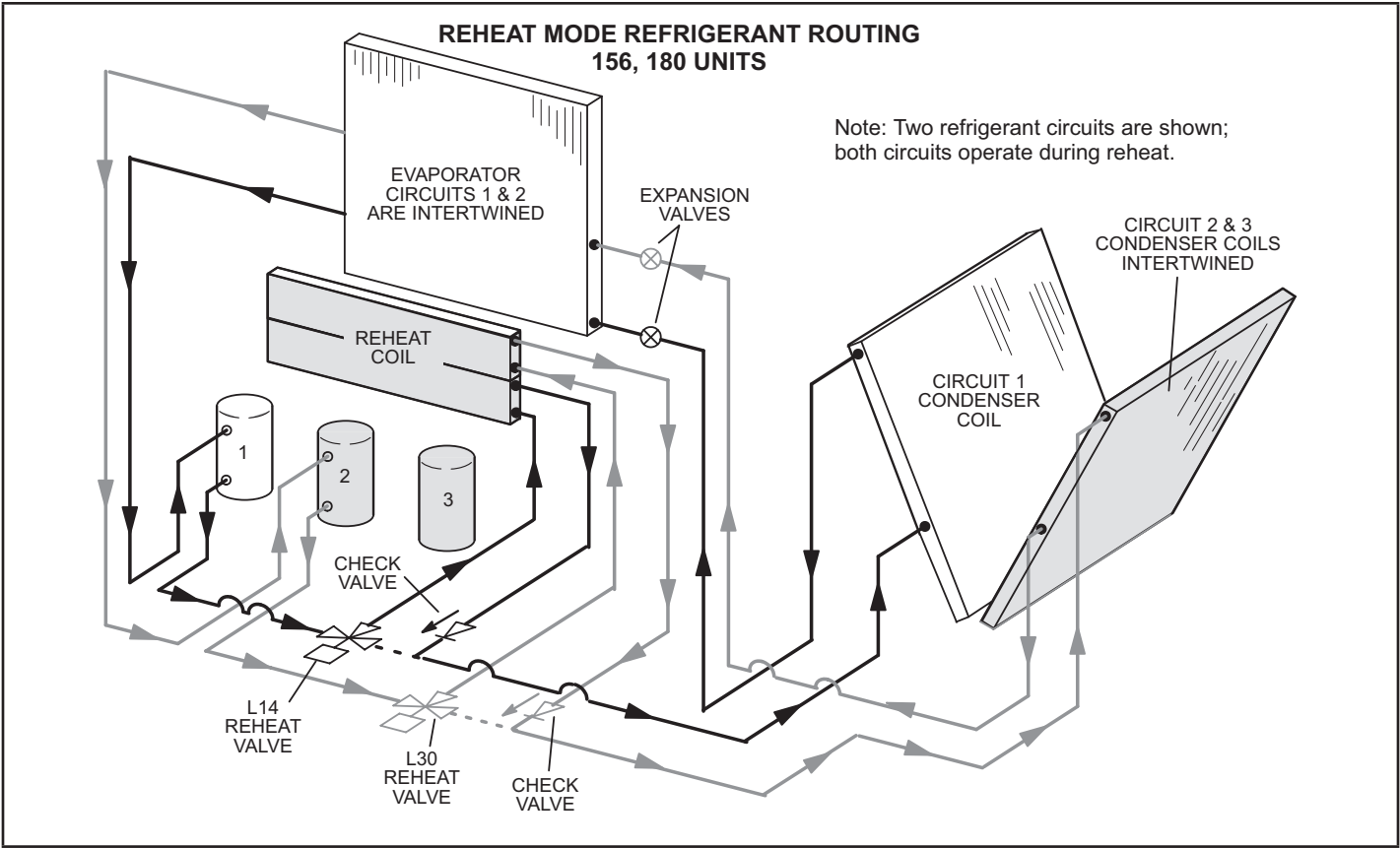
For other reheat control options, refer to the Unit Controller manual.

### Additional Cooling Stages

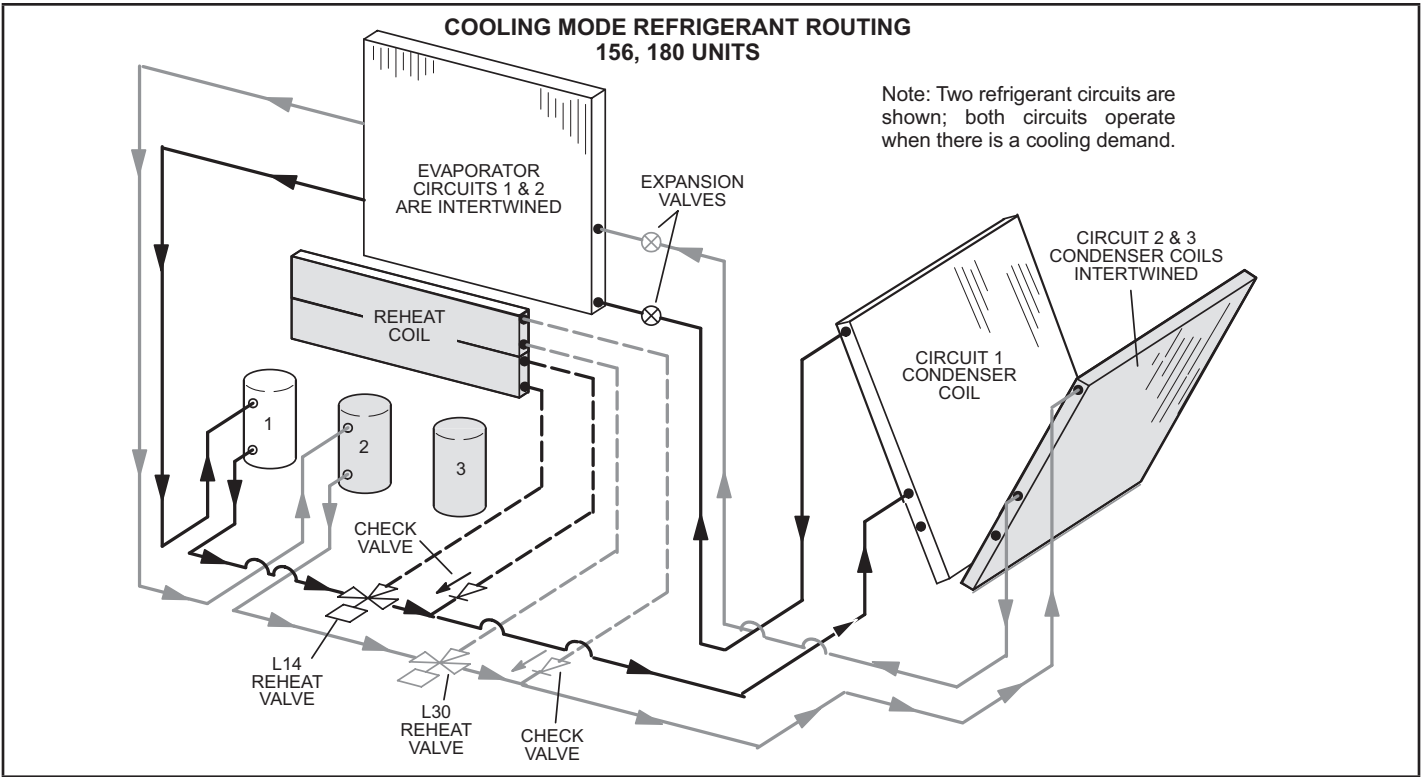
Units are shipped from the factory to provide two stages of cooling. Compressors are not de-energized when unit operation changes from cooling to reheat or from reheat to cooling. Instead, L14 and L30 reheat valves are energized (reheat) or de-energized (cooling).

**NOTE - Another thermostat staging option is available which allows both compressors to be energized during free cooling. See Unit Controller manual for details.**

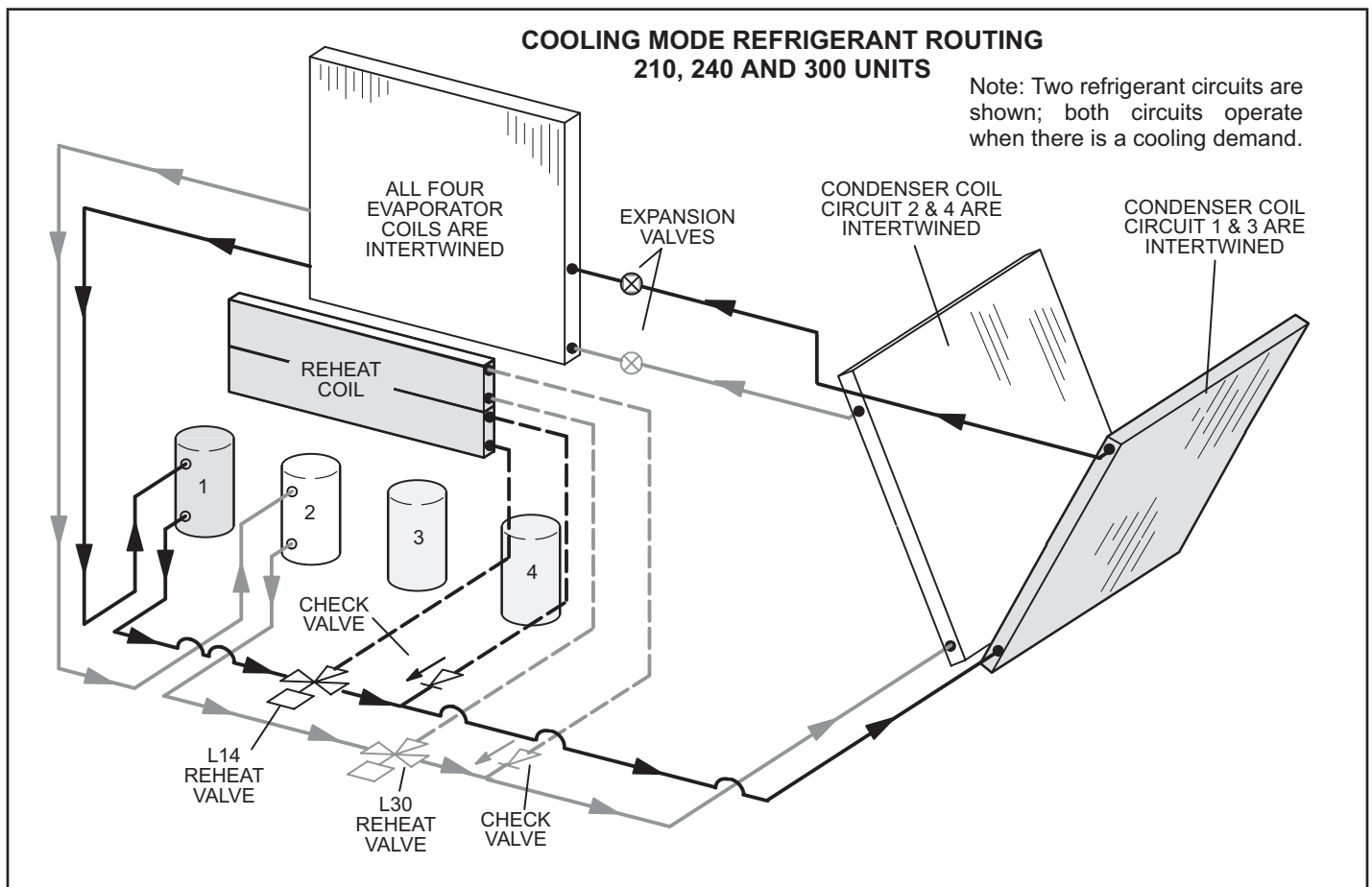
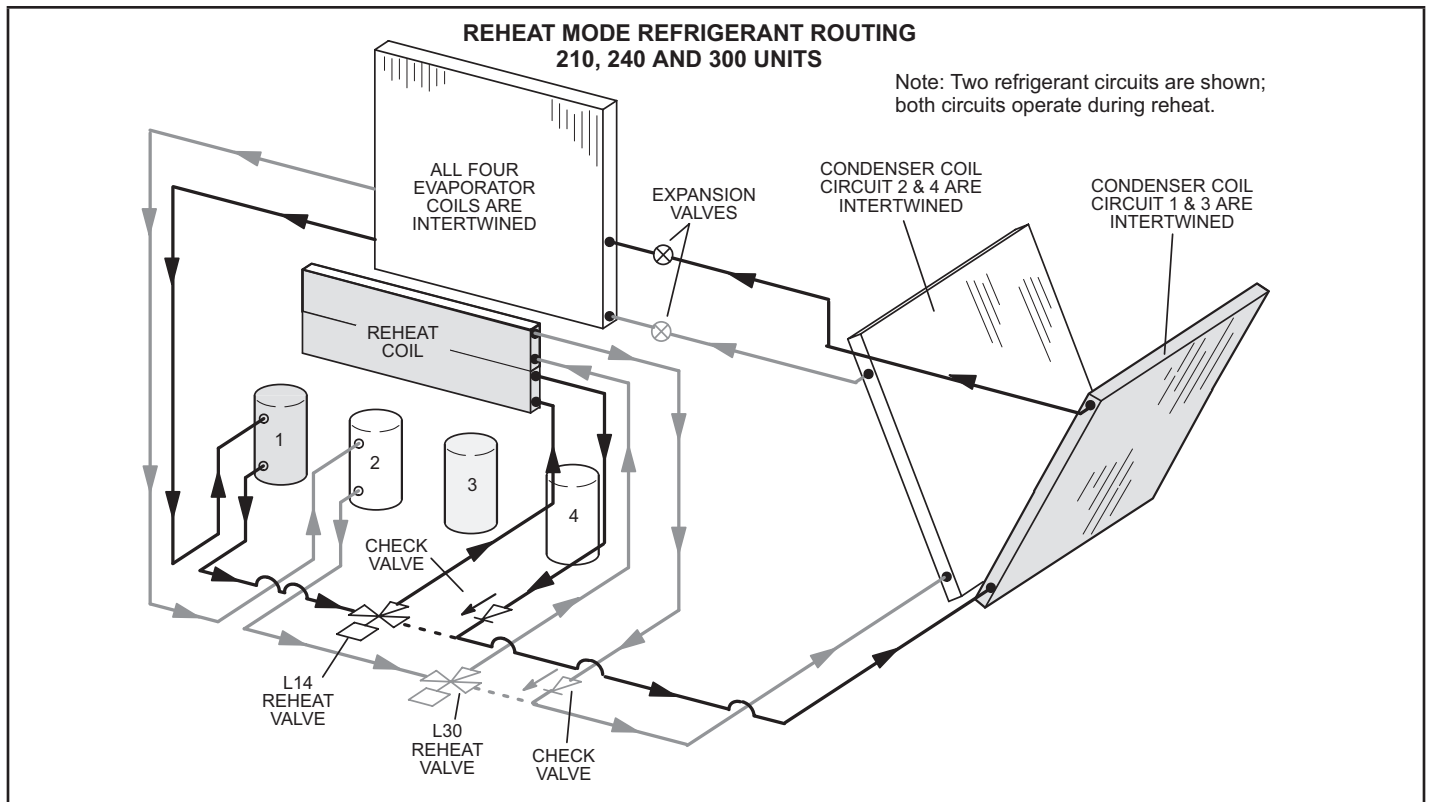




**FIGURE 21**



**FIGURE 22**



**TABLE 19**  
**REHEAT OPERATION**

Thermostat Mode With 24V Humidistat	
Humidity Demands	Operation
24V Demand for Dehumidification only	<ul style="list-style-type: none"> <li>• Compressor 1 reheat on</li> <li>• Compressor 1 operates at 100%</li> <li>• Reheat valve is energized</li> <li>• Remaining compressors are off</li> <li>• Blower and outdoor fans modulate to maintain indoor coil and discharge air temperatures</li> </ul>
24V Demand for Dehumidification only is still present after Five Minutes	<ul style="list-style-type: none"> <li>• Compressor 1 &amp; 2 reheat on</li> <li>• Compressor 1 operates at 100%</li> <li>• Reheat valves are energized</li> <li>• Remaining compressor(s) is/are off</li> <li>• Blower and outdoor fans modulate to maintain indoor coil and discharge air temperatures</li> </ul>
Thermostat Mode with Zone Relative Humidity (RH) Sensor	
Zone humidity is greater than Setpoint +2%	<ul style="list-style-type: none"> <li>• Compressor 1 reheat on</li> <li>• Compressor 1 modulates to maintain zone RH</li> <li>• Reheat valve is energized</li> <li>• Remaining compressors are off</li> <li>• Blower and outdoor fans modulate to maintain indoor coil and discharge air temperatures</li> </ul>
Zone humidity is greater than Setpoint +2% OR Zone humidity is greater than Setpoint for 5 minutes	<ul style="list-style-type: none"> <li>• Compressor 1 &amp; 2 reheat on</li> <li>• Compressor 1 modulates to maintain zone RH</li> <li>• Reheat valves are energized</li> <li>• Remaining compressor(s) is/are off</li> <li>• Blower and outdoor fans modulate to maintain indoor coil and discharge air temperatures</li> </ul>

## VIII--Multi-Staged Blower

### A-Design Specifications

Use the “Blower CFM Design Specifications” table attached to the unit (table 18 in the installation instructions) to fill in test and balance values when setting up the unit. If only high and low cooling design specifications are provided, set the medium cooling CFM at the high or low cooling design spec or any CFM between.

### B-Set Maximum CFM

Use attached table to determine highest blower CFM for appropriate unit. Adjust the blower pulley to deliver that amount of CFM with only the blower operating. See Determining Unit CFM in the Blower Operation and Adjustment section.

### C-Set Blower Speeds

- 1 - Use the following mobile service app menu to enter the blower design specified CFM into the Unit Controller. Make sure blower CFM is within limitations shown in table 20 or 21 . Refer to the Unit Controller manual provided with unit.

*RTU MENU > RTU OPTIONS > BLOWER > SPEED*

- 2 - Enter the following design specifications as shown in the attached table (table 18 in the installation instructions).

*Blower / Heat CFM*

*Cooling High CFM*

*Cooling Low CFM*

*Vent CFM*

- 3 - Adjust the blower RPM to deliver the target CFM based on the measured static pressure using the blower table.
- 4 - Measure the static pressure again and apply the static pressure and RPM to the blower tables to determine adjusted CFM.
- 5 - Repeat adjustments until design CFM is reached.

### D-Set Damper Minimum Position

To maintain required minimum ventilation air volumes when the unit is in the occupied mode, two minimum damper positions must be set.

*The Unit Controller will open the damper to “Min OCP Blwr High” when blower CFM is at or ABOVE the “midpoint” CFM.*

*The Unit Controller will open the dampers to “Min OCP Blwr Low” when blower CFM is BELOW a “midpoint” CFM.*

The Unit Controller will calculate the “midpoint” CFM.

\*Available blower speeds vary by unit and thermostat stages.

#### Set Minimum Position 1

Use the following mobile service app menu to set “Min OCP Blwr High” for the blower CFM above the “midpoint” CFM. When navigating into this menu, the Unit Controller will run damper calibration and allow damper position adjustment.

*RTU MENU > SETTINGS > RTU OPTIONS > DAMPER*

Tap “Next” to skip tabs and complete damper position calibration until “Damper Calibration Blower Speed High” tab appears.

Measure the intake air CFM. If the CFM is lower than the design specified CFM for ventilation air, use the Unit Controller to increase the damper percent open. If the CFM is higher than specified, decrease the damper percent open.

**NOTE** - *Intake air CFM can also be determined using the outdoor air temperature, return air temperature and mixed air temperature. Refer to the economizer or outdoor air damper installation instructions.*

#### Set Minimum Position 2

Use the following mobile service app menu in the Unit Controller to set “Min OCP Blwr Low” for the blower CFM below the “midpoint” CFM. When navigating into this menu, the Unit Controller will run damper calibration and allow damper position adjustment.

*RTU MENU > SETTINGS > RTU OPTIONS > DAMPER*

Tap “Next” to skip tabs and complete damper position calibration until “Damper Calibration Blower Speed High” tab appears. Measure the intake air CFM. If the CFM is lower than the design specified CFM for ventilation air, use the Unit Controller to increase the damper percent open. If the CFM is higher than specified, decrease the damper percent open.

**Note** - *Intake air CFM can also be determined using the outdoor air temperature, return air temperature and mixed air temperature. Refer to the economizer or outdoor air damper installation instructions.*

### E-Inverter Bypass Option

The supply air inverter is factory-set to by-pass the inverter manually. To by-pass the inverter and operate the blower in the constant air volume mode, use the following Unit Controller menu and set to “engaged”:

*SETTINGS > RTU OPTIONS > BLOWER > VFD BYPASS*

To configure the unit to by-pass the inverter automatically, use the following Unit Controller menu.

*SETUP > INSTALL*

Press SAVE until the menu reads:

*CONFIGURATION ID 1*

Change the 6th character position to A for automatic by-pass option.

Press SAVE

**Caution** - *Units not equipped with an inverter will have the 6th character set to N, indicating the inverter is not by-passed. The blower motor could be damaged and/or result in product or property damage if the setting is changed to automatic or manual.*

**TABLE 20**  
**HEATING, VENTILATION & SMOKE MINIMUM AND MAXIMUM CFM**

Unit			Heating CFM			Vent CFM			Smoke CFM		
Model	Speed	Heat Code	Min	Default	Max	Min	Default	Max	Min	Default	Max
LGM156U	Low, Std, Med	L, S, M	4500	5200	6250	800	1150	*	1950	5200	6250
LGM180U	Low, Std, Med	L, S, M	4500	6000	7200	800	1325	*	2250	6000	7200
LGM180U	High	H	5125								
LGM210U	Low, Std, Med	L, S, M	4500	7000	8400	800	1550	*	2625	7000	8400
LGM210U	High	H	5125								
LGM240U	Low, Std, Med	L, S, M	4500	8000	9600	800	1750	*	3000	8000	9600
LGM240U	High	H	5125								
LGM300U	Low, Std, Med	L, S, M	4500	10000	12000	800	2200	*	3750	10000	12000
LGM300U	High	H	5125								
LCM156U	All	N, E, J, K, L, P	5200	5200	6250	800	1150	*	1950	5200	6250
LCM180U	All	N, E, J, K, L, P	6000	6000	7200	800	1325	*	2250	6000	7200
LCM210U	All	N, E, J, K, L, P	6000	7000	8400	800	1550	*	2625	7000	8400
LCM240U	All	N, E, J, K, L, P	6000	8000	9600	800	1750	*	3000	8000	9600
LCM300U	All	N, E, J, K, L, P	6000	10000	12000	800	2200	*	3750	10000	12000

\*Use highest value between Heating and Cooling High CFM Max.

**TABLE 21**  
**COOLING MINIMUM AND MAXIMUM CFM**

Model	Cooling Low CFM			Cooling High CFM		
	Default	Min	Max	Default	Min	Max
156U	1150	800	*	4550	3250	6240
180U	1325	800	*	5250	3750	7200
210U	1550	800	*	6125	4375	8400
240U	1750	800	*	7000	5000	9600
300U	2200	800	*	8750	6250	12000

\*Use Cooling High CFM Max.

## IX-VAV System

Units contain a supply air blower equipped with a variable frequency drive A96 (VFD) which varies supply air CFM. The supply air VFD (A96) is located in the control area. See figure 26.

### A-Start-Up

- 1 - A pressure transducer (A30) is shipped in a box in the blower compartment. Install the transducer according to manufacturer's instructions.

*Note - Make sure the transducer is installed in the main duct at least 2/3 of the distance away from the unit.*

- 2 - Two twisted pairs of shielded cable must be used to connect the pressure transducer. See figure 36. J/ P378 connector is hanging in the control box.
- 3 - Open all zone dampers and/or boxes.
- 4 - Locate the A55 Unit Controller. Refer to figure 26.
- 5 - Use the mobile service app to calibrate the blower CFM. Select this menu to start the blower:

SETUP > TEST & BALANCE > BLOWER

The mobile app will display the percent of blower speed. Adjust blower speed percentage to meet design airflow specifications. Allow blower speed to stabilize.

- 6 - Press NEXT and follow the instructions to calibrate static pressure. If the static pressure meets the design specification, press NEXT again to set the setpoint. If the static pressure does not meet the design specification, adjust the pressure and press NEXT to set the setpoint.
- 7 - Record new setpoints in table 22.
- 8 - If the desired CFM cannot be met with current pulley setup, refer to the Blower Operation and Adjustments section to adjust CFM.

TABLE 22

RECORD ADJUSTED SETPOINTS

Parameter	Setpoint Description	Setpoint "w.c.	Display Setting
386	Smoke		
387	Ventilation		
388	Heating		
389	Cooling		

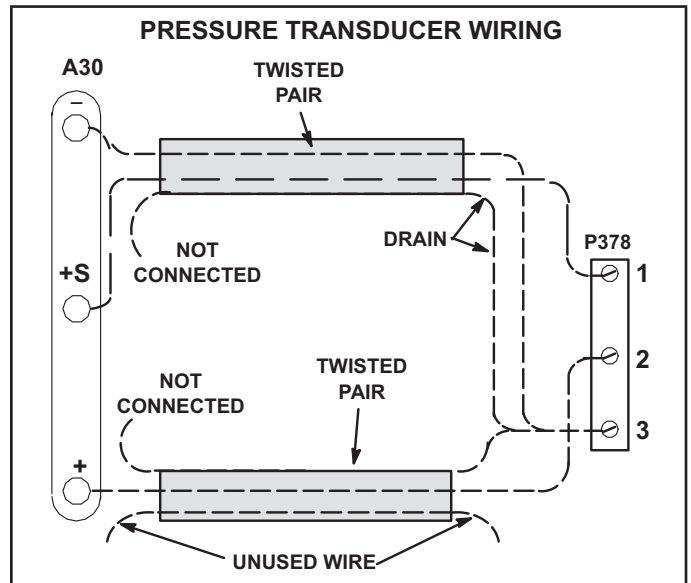


FIGURE 25

**Note -** The Unit Controller will lock-out the unit for 5 minutes if static pressure exceeds 2.0" w.c. for 20 seconds. The Unit Controller will permanently shut down the unit after three occurrences. See mobile service app parameters 110, 42, and 43 to adjust default values

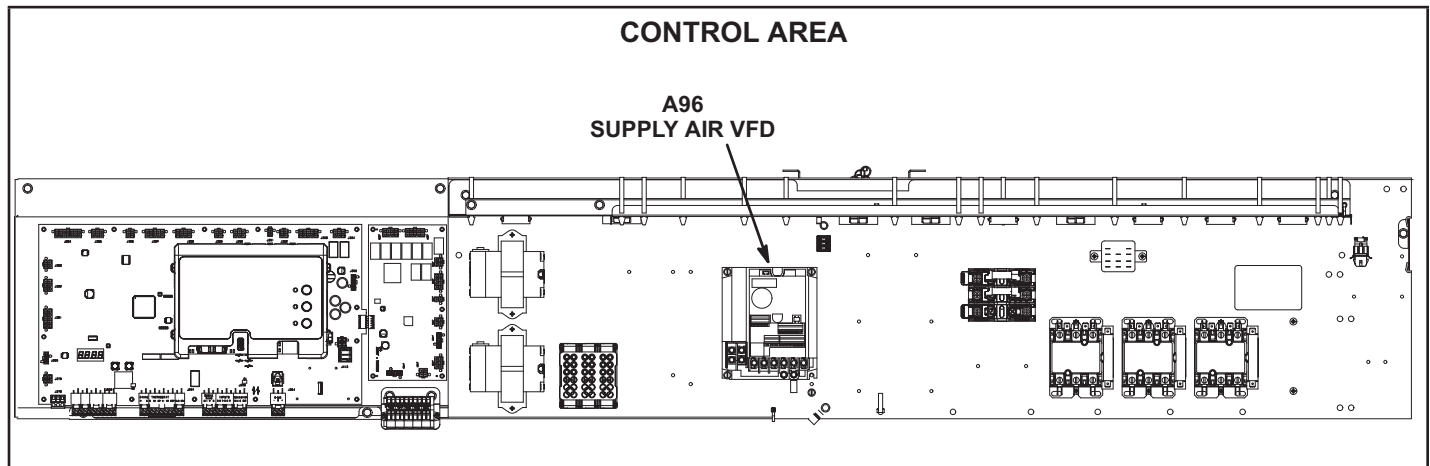


FIGURE 26



## B-Unit Operation

Use the mobile app to check unit mechanical operation. See the Service - Test section of the Unit Controller manual.

## C-Manual Supply Air VFD Bypass

**IMPORTANT - All dampers must be open to prevent damage to duct work and dampers.**

**Note - This section does not apply to units equipped with optional automatic VFD bypass. That option will automatically change from multi-stage air volume to constant air volume operation in the event of VFD failure.**

Manually change blower operation to constant air volume as follows:

- 1 - Disconnect all power to unit and **WAIT AT LEAST 10 MINUTES** before opening the VFD cover.

### ⚠ WARNING

**ELECTRICAL SHOCK HAZARD.**

**STOP!** Before you continue, make sure that power to the VFD has been off for at least 10 minutes. The capacitor in the VFD holds high voltage power for up to 10 minutes after power has been disconnected.

- 2 - Locate P246 and P247 connectors near the VFD. See figure 27.
- 3 - Disconnect P246 from P246 (power in to VFD) and P247 from P247 (power out to blower). See figure 28.
- 4 - Connect P246 to P247. See figure 29.

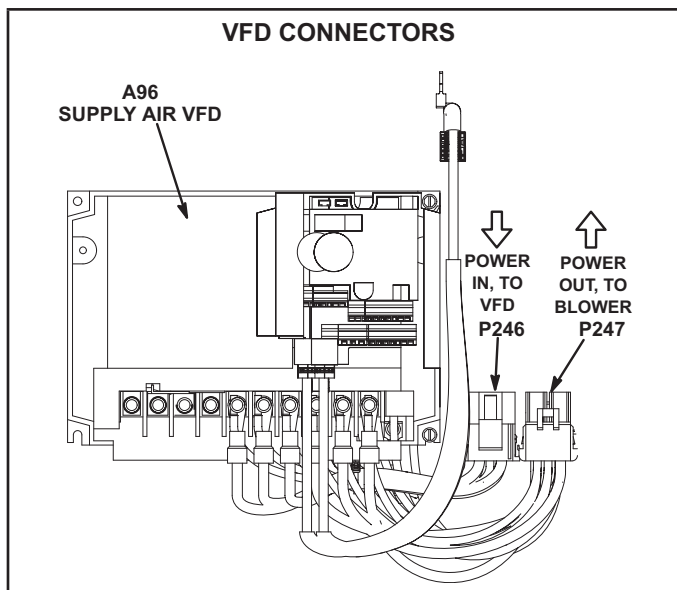


FIGURE 27

- 5 - Restore power to unit. Blower will operate in constant air volume (CAV) mode.

**Note - The indoor blower motor will start as soon as the main unit power is restored. In manual bypass, the blower will run regardless of thermostat signals until main unit power is turned off. Manual bypass is meant for emergency operation only and not long-term usage.**

- 6 - Check the indoor blower motor nameplate for full load amperage (FLA) value. Measure the amp readings from the indoor blower motor operating in bypass mode. If measured amps are higher than nameplate FLA value, decrease the CFM by opening (turning counterclockwise) the motor pulley. See figure 9. Do not exceed minimum and maximum number of pulley turns as shown in table 5.

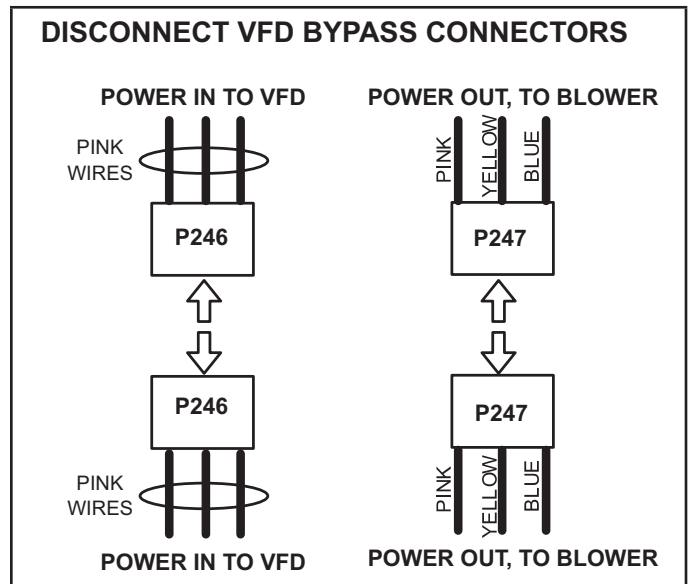


FIGURE 28

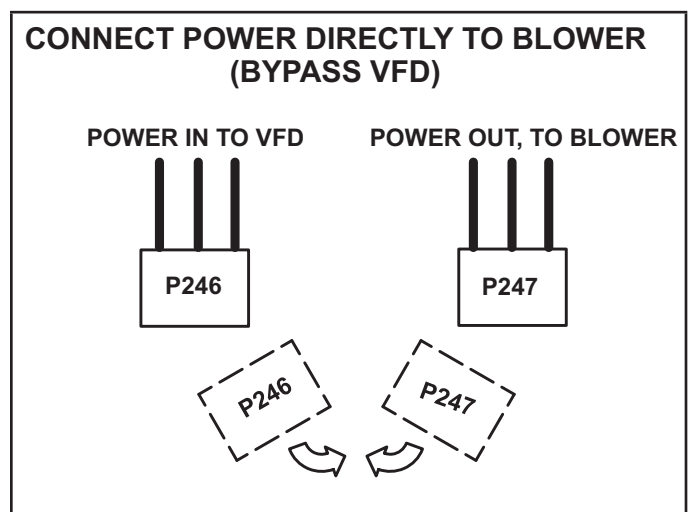
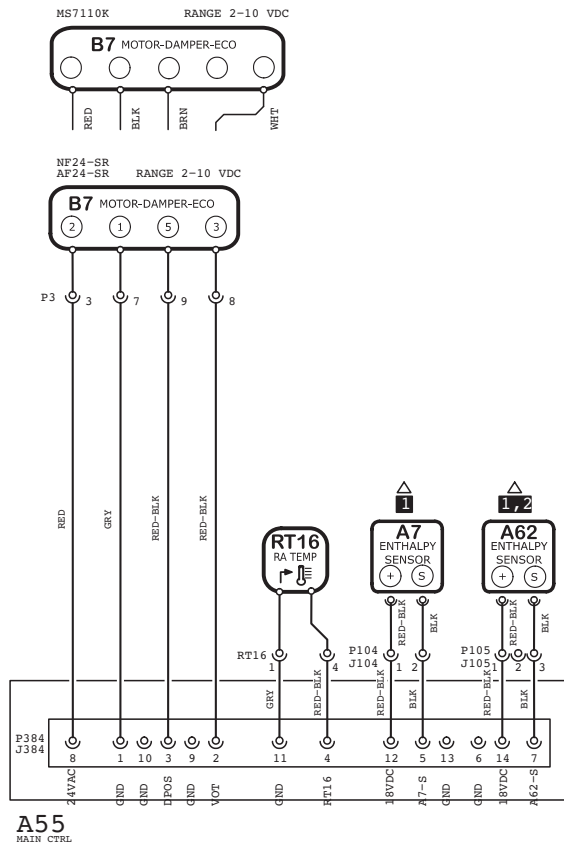


FIGURE 29

# Economizer

Rev 0  
538072-01



NOTES	
1	A7 AND A62 NOT USED FOR SENSIBLE TEMPERATURE CONTROL
2	FOR UNIT DIFFERENTIAL ENTHALPY CONTROL, ADD A62 RETURN AIR ENTHALPY SENSOR

KEY LIST	
LOCATION	COMPONENT DESCRIPTION
CC05	A7 SENSOR, SOLID STATE ENTHALPY
AA06	A55 CONTROL BOARD, MAIN
DD05	A62 SENSOR, ENTHALPY INDOOR
BB02	B7 MOTOR, DAMPER ECONOMIZER
CC05	RT16 SENSOR, RETURN AIR TEMP

Model: LCM, LGM Series RTU Economizer & Motorized OAD

Voltage: All Voltages

Supersedes: N/A

Form No:  
538072-01

© 2019  
HTG CLG CLG ACCS ACCS  
SEC SEC SEC SEC SEC  
A B B3 C D  
WIRING DIAGRAM FLOW

Rev:0

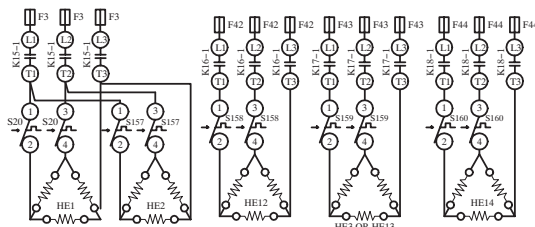
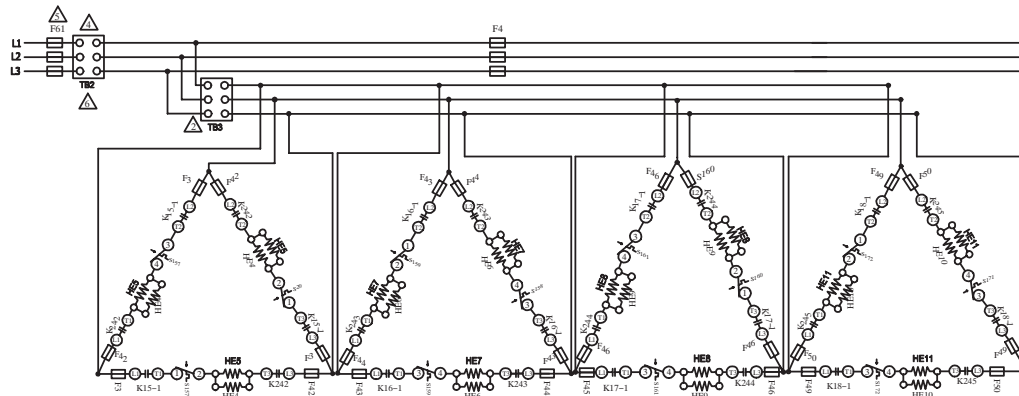
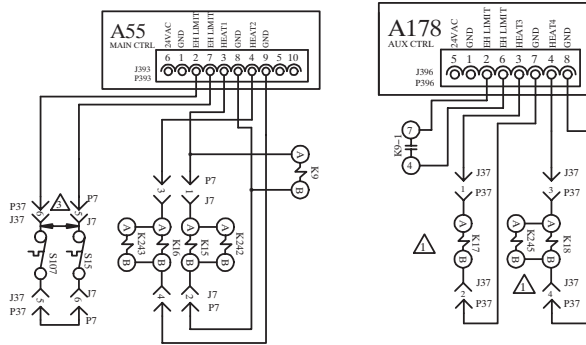


# EHA15/90 Y Voltage

J/P	JACK/PLUG
7	ELECTRIC HEAT CONTROL
37	ELECTRIC HEAT CONTROL


KEY	DESCRIPTION
A55	CONTROL BOARD LENNOX
A178	BOARD, COMP 3 & 4, C3 2nd STAGE HEAT
F3	FUSE, ELECTRIC HEAT
F4	FUSE, UNIT
F42	FUSE, ELECTRIC HEAT 1 A, 2A
F43	FUSE, ELECTRIC HEAT 3
F44	FUSE, ELECTRIC HEAT 4

F45	FUSE, ELECTRIC HEAT 5
F46	FUSE, ELECTRIC HEAT 6
F49	FUSE, ELECTRIC HEAT 7
F50	FUSE, ELECTRIC HEAT 8
F61	FUSE, UNIT - SCGR
HE1	ELEMENT, ELECTRIC HEAT 1
HE2	ELEMENT, ELECTRIC HEAT 2
HE3	ELEMENT, ELECTRIC HEAT 3
HE4	ELEMENT, ELECTRIC HEAT 4
HE5	ELEMENT, ELECTRIC HEAT 5
HE6	ELEMENT, ELECTRIC HEAT 6
HE7	ELEMENT, ELECTRIC HEAT 7
HE8	ELEMENT, ELECTRIC HEAT 8
HE9	ELEMENT, ELECTRIC HEAT 9
HE10	ELEMENT, ELECTRIC HEAT 10
HE11	ELEMENT, ELECTRIC HEAT 11
HE12	ELEMENT, ELECTRIC HEAT 12
HE13	ELEMENT, ELECTRIC HEAT 13
HE14	ELEMENT, ELECTRIC HEAT 14
K9-1	RELAY, HEAT
K15-1	CONTACTOR, ELECTRIC HEAT 1,2
K16-1	CONTACTOR, ELECTRIC HEAT 1A,2A
K17-1	CONTACTOR, ELECTRIC HEAT 3,4
K18-1	CONTACTOR, ELECTRIC HEAT 5,6
K242	CONTACTOR, ELECTRIC HEAT 1
K243	CONTACTOR, ELECTRIC HEAT 2
K244	CONTACTOR, ELECTRIC HEAT 3
K245	CONTACTOR, ELECTRIC HEAT 4
S15	SWITCH, LIMIT PRIMARY ELECTRIC HEAT
S20	SWITCH, LIMIT SECONDARY ELECTRIC HEAT 1,2
S107	SWITCH, PRIMARY ELECTRIC HEAT
S157	SWITCH, LIMIT SECONDARY ELECTRIC HEAT 2
S158	SWITCH, LIMIT SECONDARY ELECTRIC HEAT 3
S159	SWITCH, LIMIT SECONDARY ELECTRIC HEAT 4
S160	SWITCH, LIMIT SECONDARY ELECTRIC HEAT 5
S161	SWITCH, LIMIT SECONDARY ELECTRIC HEAT 6
S171	SWITCH, LIMIT SECONDARY ELECTRIC HEAT 7
S172	SWITCH, LIMIT SECONDARY ELECTRIC HEAT 8
TB2	TERMINAL STRIP, UNIT
TB3	TERMINAL STRIP, ELECTRIC HEAT

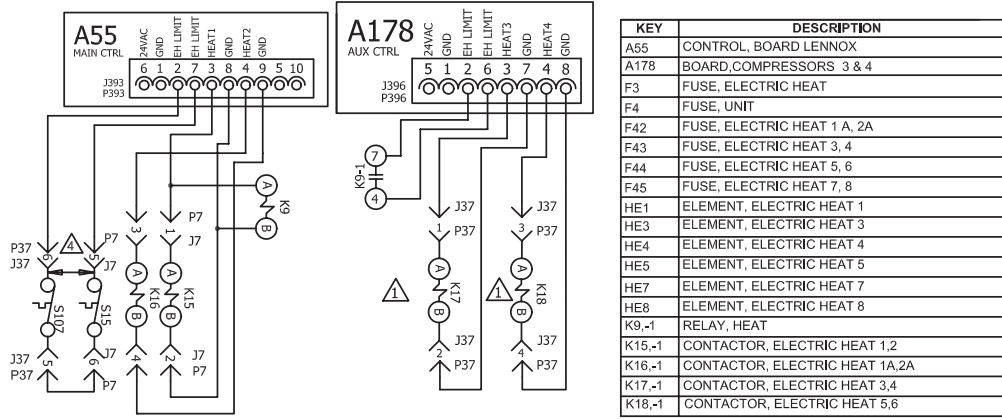


- DESIGNATION      VOLTAGE  
 Y                      208-250/0/3  
 C UNITS 156 TO 300
- △ NOT USED ON 15 AND 30KW UNITS
  - △ TB3 IS USED IN SOME UNITS
  - △ REMOVE PLUG WHEN FIELD INSTALLING ELECTRIC HEAT
  - △ TB2, CB10 OR S48 MAY BE USED ON NON SCGR UNITS
  - △ F61 USED ON SCGR OPTION UNITS ONLY
  - △ TB2 IS USED IN SOME SCGR OPTION UNITS ONLY
- ← DENOTES OPTIONAL COMPONENTS

KW	HE1	HE2	HE3	HE4	HE5	HE6	HE7	HE8	HE9	HE10	HE11	HE12	HE13	HE14
15	7.5	7.5												
30			15	15										
45	15										7.5	15	7.5	
60	15										15	15	15	
90	15		15			15	15			15	15			

2020/10	 WIRING DIAGRAM 538127-01	10/20
	HEATING <b>ELECTRIC HEAT</b> <b>E1EH, EHA - 15, 30, 45, 60, 90, - Y</b>	
SECTION A		REV 0
Supersedes	New Form No. <b>538127-01</b>	

# EHA-15/90 G Voltage



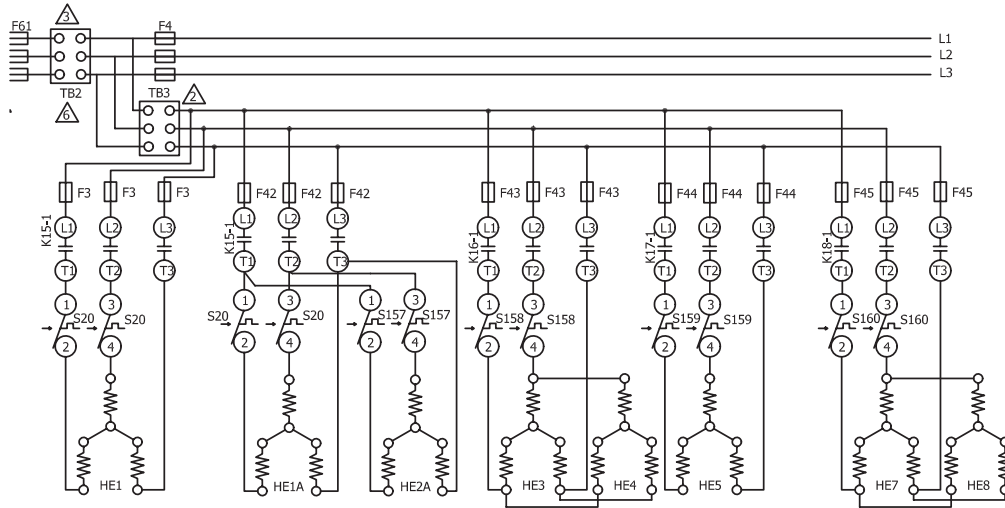
KEY	DESCRIPTION
A55	CONTROL, BOARD LENNOX
A178	BOARD,COMPRESSORS 3 & 4
F3	FUSE, ELECTRIC HEAT
F4	FUSE, UNIT
F42	FUSE, ELECTRIC HEAT 1 A, 2A
F43	FUSE, ELECTRIC HEAT 3, 4
F44	FUSE, ELECTRIC HEAT 5, 6
F45	FUSE, ELECTRIC HEAT 7, 8
HE1	ELEMENT, ELECTRIC HEAT 1
HE3	ELEMENT, ELECTRIC HEAT 3
HE4	ELEMENT, ELECTRIC HEAT 4
HE5	ELEMENT, ELECTRIC HEAT 5
HE7	ELEMENT, ELECTRIC HEAT 7
HE8	ELEMENT, ELECTRIC HEAT 8
K9-1	RELAY, HEAT
K15-1	CONTACTOR, ELECTRIC HEAT 1,2
K16-1	CONTACTOR, ELECTRIC HEAT 1A,2A
K17-1	CONTACTOR, ELECTRIC HEAT 3,4
K18-1	CONTACTOR, ELECTRIC HEAT 5,6

S15	SWITCH, LIMIT PRIMARY ELECTRIC HEAT
S20	SWITCH, LIMIT SECONDARY ELECTRIC HEAT 1,2
S107	SWITCH, PRIMARY ELECTRIC HEAT
S157	SWITCH, LIMIT SECONDARY ELECTRIC HEAT 1A
S158	SWITCH, LIMIT SECONDARY ELECTRIC HEAT 2A
S159	SWITCH, LIMIT SECONDARY ELECTRIC HEAT 3,4
S160	SWITCH, LIMIT SECONDARY ELECTRIC HEAT 5,6
TB2	TERMINAL STRIP, UNIT
TB3	TERMINAL STRIP, ELECTRIC HEAT

J/P	DESCRIPTION
7	ELECTRIC HEAT CONTROL
37	ELECTRIC HEAT CONTROL


DESIGNATION	VOLTAGE
G	460/60/3

- ⚠ NOT USED ON 15 AND 30KW UNITS
- ⚠ TB3 IS USED IN SOME UNITS
- ⚠ TB2, S48 OR CB10 MAY BE USED
- ⚠ REMOVE JUMPER PLUG WHEN FIELD INSTALLING ELECTRIC HEAT
- ⚠ F61 USED ON UNITS WITH SCCR OPTION
- ⚠ TB2 IS USED IN SOME SCCR OPTION UNITS ONLY



KW	HE1	HE1A	HE2A	HE3	HE4	HE5	HE7	HE8
15		7.5	7.5					
30		15	15					
45	15			7.5		15	7.5	
60	15			15		15	15	
90	15			15	15	15	15	15

← DENOTES OPTIONAL COMPONENTS

2020/10	 WIRING DIAGRAM 538126-01	10/20
HEATING ELECTRIC HEAT E1EH,EHA-15,30,45,60,90 - G		
SECTION A		REV.0
Supersedes	New Form No. 538126-01	

**SEQUENCE OF OPERATION**  
**EHA-15, 30, 45, 60, 90 - Y & G**

The Y voltage diagram use elements configured in a Wye. The G and J voltage diagram use elements configured in a Delta. Both diagrams follow the following sequence of operation:

**NOTE:** Two electric heat sections are used in all 15kW through 90kW heaters. The heat sections are labelled first electric heat section (left side) and second electric heat section (right side). See figure 14.

**NOTE:** In the case of EHA 15 and 30kW, the second heat section (right side) is a slave (only has electric heat elements and a limit). Line voltage is supplied to elements in both heat section one (left side) and two (right side) by the contactors in heat section one (left side).

**HEATING ELEMENTS:**

- 1 - Terminal strip TB3 is energized when the unit disconnect closes. TB3 supplies line voltage to electric heat elements HE1 through HE14. Each heating element is protected by fuse F3.

**FIRST STAGE HEAT:**

- 2 - Heating demand initiates at W1 in thermostat.
- 3 - 24VAC is routed to the main control module A55. After A55 proves N.C. primary limits S15 (heat section one, left side), S107 (heat section two, right side), the electric heat contactor K15 and heat relay K9 are energized.
- 4 - N.O. contact K15-1 closes allowing the first bank of elements in heat section one (left side) to be energized.
- 5 - At the same time, N.O. contacts K9-1 close. A N.O. contact in A55 closes, energizing electric heat relay K17.
- 6 - N.O. contacts K17-1 close allowing the first set of elements in heat section two (right side) to be energized.

**SECOND STAGE HEAT:**

- 7 - With the first stage heat operating, an additional heating demand initiates at W2 in the thermostat.
- 8 - 24VAC is routed through the main control module A55, which in turn energizes the electric heat contactor K16.
- 9 - N.O. contacts K16-1 close allowing the second set of elements in heat section one (left side) to be energized.
- 10 - Simultaneous with step eight, a N.O. contact in the A55 Unit controller closes, allowing 24VAC to energize electric heat contactor K18.
- 11 - N.O. contacts K18-1 close allowing the second set of elements in heat section two (right side) to be energized.

**END OF SECOND STAGE HEAT:**

- 12 - Heating demand is satisfied. Terminal W2 in the thermostat is de-energized.
- 13 - Electric heat contactors K16 and K18 are de-energized.
- 14 - The second set of electric heat elements in heat sections one (left side) and two (right side) are deenergized.

**END OF FIRST STAGE HEAT:**

- 15 - Heating demand is satisfied. Terminal W1 in the thermostat is de-energized.
- 16 - Electric heat contactors K15 and K17 are de-energized.

The first set of electric heat elements in heat sections one (left side) and two (right side) are de-energized.



### **Sequence of Operation LGM/LCM156 & 180U**

- 1 - Line voltage from TB13 energizes transformer T1 and T18. Transformer T1 and T18 provides 24VAC power to the main controller A55. The transformers also provide 24VAC power to the unit cooling, heating and blower controls and thermostat

### **ECONOMIZER OPERATION**

- 2 - The A55 Unit Controller receives a demand and energizes exhaust fan relay K65 and K231 with 24VAC at 50% (travel) outside air damper open (adjustable).
- 3 - N.O. K65-1, K65-2, K231-01 and K231-02 close, energizing exhaust fan motors B10 and B11.

### **1ST STAGE COOLING**

- 4 - First stage cooling demand energizes Y1 and G in the thermostat. G energizes blower, if blower is not already running (see step 3).
- 5 - 24VAC is routed to the A55 Unit Controller. After A55 proves N.C. low pressure switch S87 , high pressure switch S4 and high temperature limits S5 compressor contactor K1 is energized.
- 6 - N.O. contacts K1-1 close energizing compressor B1.
- 7 - A178 energizes outdoor fans B21 and B22.
- 8 - Relay K191 opens de-energizing compressor 1 crankcase heater HR1.

### **2ND STAGE COOLING**

- 9 - Second stage cooling demand energizes Y2.
- 10 - After A55 proves N.C. low pressure switch S88 and S98, and N.C. high pressure switch S7 and 228, contactors K1 and K14 are energized.
- 11 - N.O. K2 closes energizing compressor B2 and de-energizing crankcase heater HR2.
- 12 - N.O. K14 closes energizing compressor B13, de-energizing HR5.
- 13 - A178 energizes outdoor fans B4 and B5.

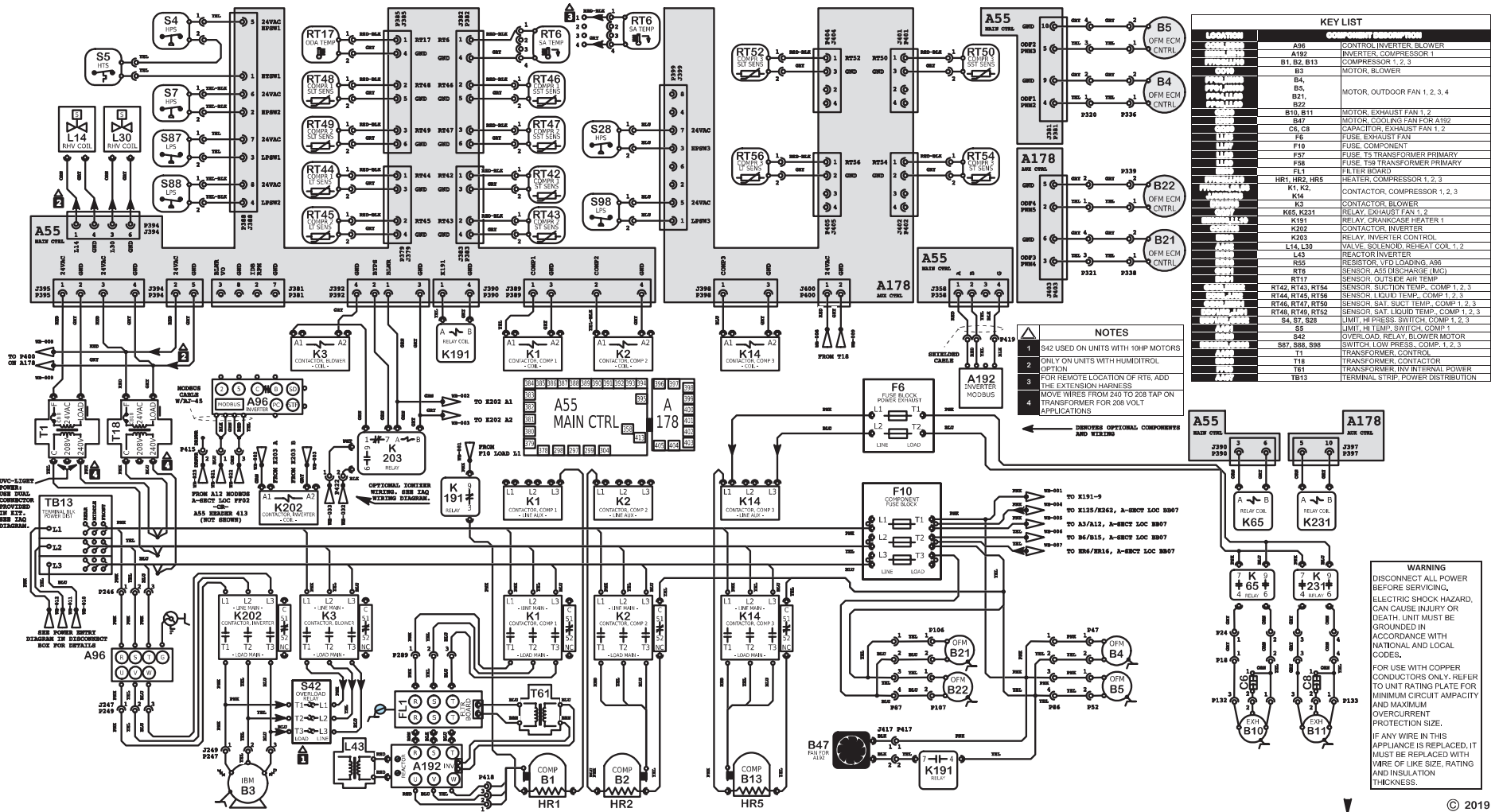
### **BLOWER OPERATION *With By Pass***

- 1 - Control inverter A96 energizes contactor K202 and main control A55 energizes relay 203.
- 2 - K203-1 N.C. contacts open to de-energize K3 relay coil. K3 contacts open to interrupt power to B3 blower motor through K3 N.O. relay contacts.
- 3 - K202 contacts close to allow power to B3 blower motor from A96.

### **BLOWER OPERATION *No By-Pass***

- 1 - Control inverter A96 energizes B3 on a G demand.

# LGM/LCM156U/180U Y Voltage With By-Pass



**KEY LIST**

Location	Component Description
A96	CONTROL INVERTER BLOWER
A192	INVERTER COMPRESSOR 1
B1, B2, B13	COMPRESSOR 1, 2, 3
B3	MOTOR, BLOWER
B4, B5, B21, B22	MOTOR, OUTDOOR FAN 1, 2, 3, 4
B10, B11	MOTOR, EXHAUST FAN 1, 2
B47	MOTOR, COOLING FAN FOR A192
CH, C3	CAPACITOR, EXHAUST FAN 1, 2
F6	FUSE, EXHAUST FAN
F10	FUSE, COMPONENT
F57	FUSE, TO TRANSFORMER PRIMARY
F58	FUSE, T59 TRANSFORMER PRIMARY
FL1	FILTER BOARD
HR1, HR2, HR5	HEATER, COMPRESSOR 1, 2, 3
K1, K2	CONTACTOR, COMPRESSOR 1, 2, 3
K3	CONTACTOR, BLOWER
K65, K231	RELAY, EXHAUST FAN 1, 2
K191	RELAY, GRABKASP HEATER 1
K202	CONTACTOR, INVERTER
K203	RELAY, INVERTER CONTROL
L16, L30	VALVE, REFRIGERANT, REHEAT COIL, 1, 2
L43	REACTOR, INVERTER
R55	RESISTOR, VFD LOADING, A/B
R78	RESISTOR, A/C EXCHANGE (RAC)
RT17	SENSOR, OUTSIDE AIR TEMP
RT42, RT43, RT54	SENSOR, SUCTION TEMP, COMP 1, 2, 3
RT44, RT45, RT56	SENSOR, LIQUID TEMP, COMP 1, 2, 3
RT46, RT47, RT50	SENSOR, SAT. LIQUID TEMP, COMP 1, 2, 3
RT48, RT49, RT52	SENSOR, SAT. LIQUID TEMP, COMP 1, 2, 3
S4, S7, S28	LIMIT, HI TEMP, SWITCH COMP 1, 2, 3
S5	LIMIT, HI TEMP, SWITCH COMP 1
S42	OVERLOAD, RELAY, BLOWER MOTOR
S87, S88, S98	SWITCH, LOW PRESS, COMP 1, 2, 3
T1	TRANSFORMER, CONTROL
T16	TRANSFORMER, CONTACTOR
T61	TRANSFORMER, INV. INTERNAL POWER
TB13	TERMINAL STRIP, POWER DISTRIBUTION

- NOTES**
- 1 S42 USED ON UNITS WITH 10HP MOTORS
  - 2 ONLY ON UNITS WITH HUMIDITROL OPTION
  - 3 FOR REMOTE LOCATION OF RT6, ADD THE EXTENSION WIRE/SS MOVE WIRES FROM 205 TO 208 TAP ON TRANSFORMER FOR 208 VOLT APPLICATIONS
  - 4 REFER TO OPTIONAL COMPONENTS AND KEYING

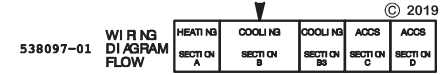
**WARNING**

DISCONNECT ALL POWER BEFORE SERVICING. ELECTRIC SHOCK HAZARD, CAN CAUSE INJURY OR DEATH. UNIT MUST BE GROUNDED IN ACCORDANCE WITH NATIONAL AND LOCAL CODES.

FOR USE WITH COPPER CONDUCTORS ONLY. REFER TO UNIT RATING PLATE FOR MINIMUM CIRCUIT AMPACITY AND MAXIMUM OVERCURRENT PROTECTION SIZE.

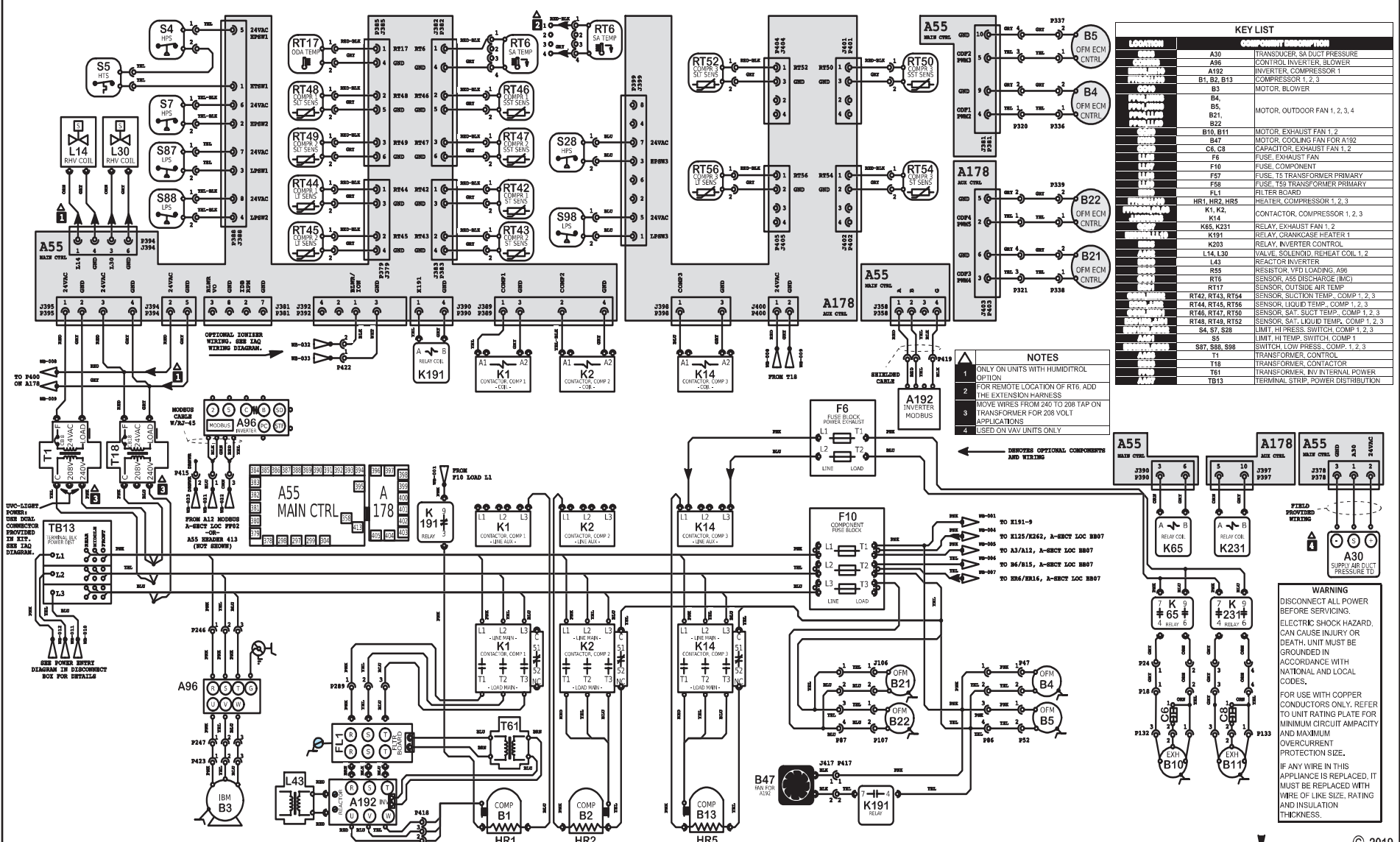
IF ANY WIRE IN THIS APPLIANCE IS REPLACED, IT MUST BE REPLACED WITH WIRE OF LIKE SIZE, RATING AND INSULATION THICKNESS.

LCM, LGM 156U, 180U - Y-VOLT  
 COOLING - MSRV WITH BYPASS - 3 COMPRESSORS, 4 CONDENSER FANS



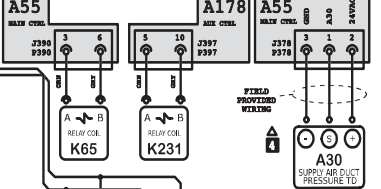


# LGM/LCM156U/180U Y Voltage No By-Pass



KEY LIST	
LOCATION	COMPONENT DESCRIPTION
A30	TRANSFORMER, SA DUCT PRESSURE
A96	CONTROL INVERTER, BLOWER
A192	INVERTER, COMPRESSOR 1
B1, B2, B3	COMPRESSOR 1, 2, 3
B3	MOTOR, BLOWER
B4, B5, B21, B22	MOTOR, OUTDOOR FAN 1, 2, 3, 4
B10, B11	MOTOR, EXHAUST FAN 1, 2
S47	MOTOR, COOLING FAN FOR A192
C8, C8	CAPACITOR, EXHAUST FAN 1, 2
F6	FUSE, EXHAUST FAN
F10	FUSE, COMPONENT
F57	FUSE, T5 TRANSFORMER PRIMARY
F58	FUSE, T59 TRANSFORMER PRIMARY
FL1	FILTER BOARD
HR1, HR2, HR5	HEATER, COMPRESSOR 1, 2, 3
K1, K2, K14	CONTACTOR, COMPRESSOR 1, 2, 3
K65, K231	RELAY, EXHAUST FAN 1, 2
K191	RELAY, CRANKCASE HEATER 1
K203	RELAY, INVERTER CONTROL
L14, L30	VALVE, SOLENOID REHEAT COIL 1, 2
L43	REACTOR INVERTER
R95	RESISTOR, VFD LOADING, ASB
RT6	SENSOR, ASB DISCHARGE (IMC)
RT17	SENSOR, OUTSIDE AIR TEMP
RT42, RT43, RT54	SENSOR, SUCTION TEMP, COMP 1, 2, 3
RT44, RT45, RT56	SENSOR, LIQUID TEMP, COMP 1, 2, 3
RT46, RT47, RT50	SENSOR, SAT. SUCT. TEMP, COMP 1, 2, 3
RT48, RT49, RT52	SENSOR, SAT. LIQUID TEMP, COMP 1, 2, 3
S4, S7, S28	LIMIT, HI PRESS. SWITCH, COMP 1, 2, 3
S8	LIMIT, HI TEMP. SWITCH, COMP 1, 2, 3
S87, S88, S98	SWITCH, LOW PRESS., COMP. 1, 2, 3
T1	TRANSFORMER, CONTROL
T18	TRANSFORMER, CONTACTOR
T61	TRANSFORMER, INV INTERNAL POWER
TB13	TERMINAL STRIP, POWER DISTRIBUTION

- NOTES**
- ONLY ON UNITS WITH HUMIDITROL OPTION
  - FOR REMOTE LOCATION OF RT6, ADD THE EXTENSION HARNESS
  - MOVE WIRES FROM 240 TO 208 TAP ON TRANSFORMER FOR 208 VOLT APPLICATIONS
  - USED ON VAV UNITS ONLY



**WARNING**

DISCONNECT ALL POWER BEFORE SERVICING. ELECTRIC SHOCK HAZARD. CAN CAUSE INJURY OR DEATH. UNIT MUST BE GROUNDED IN ACCORDANCE WITH NATIONAL AND LOCAL CODES.

FOR USE WITH COPPER CONDUCTORS ONLY. REFER TO UNIT RATING PLATE FOR MINIMUM CIRCUIT AMPACITY AND MAXIMUM OVERCURRENT PROTECTION SIZE.

IF ANY WIRE IN THIS APPLIANCE IS REPLACED, IT MUST BE REPLACED WITH WIRE OF LIKE SIZE, RATING AND INSULATION THICKNESS.

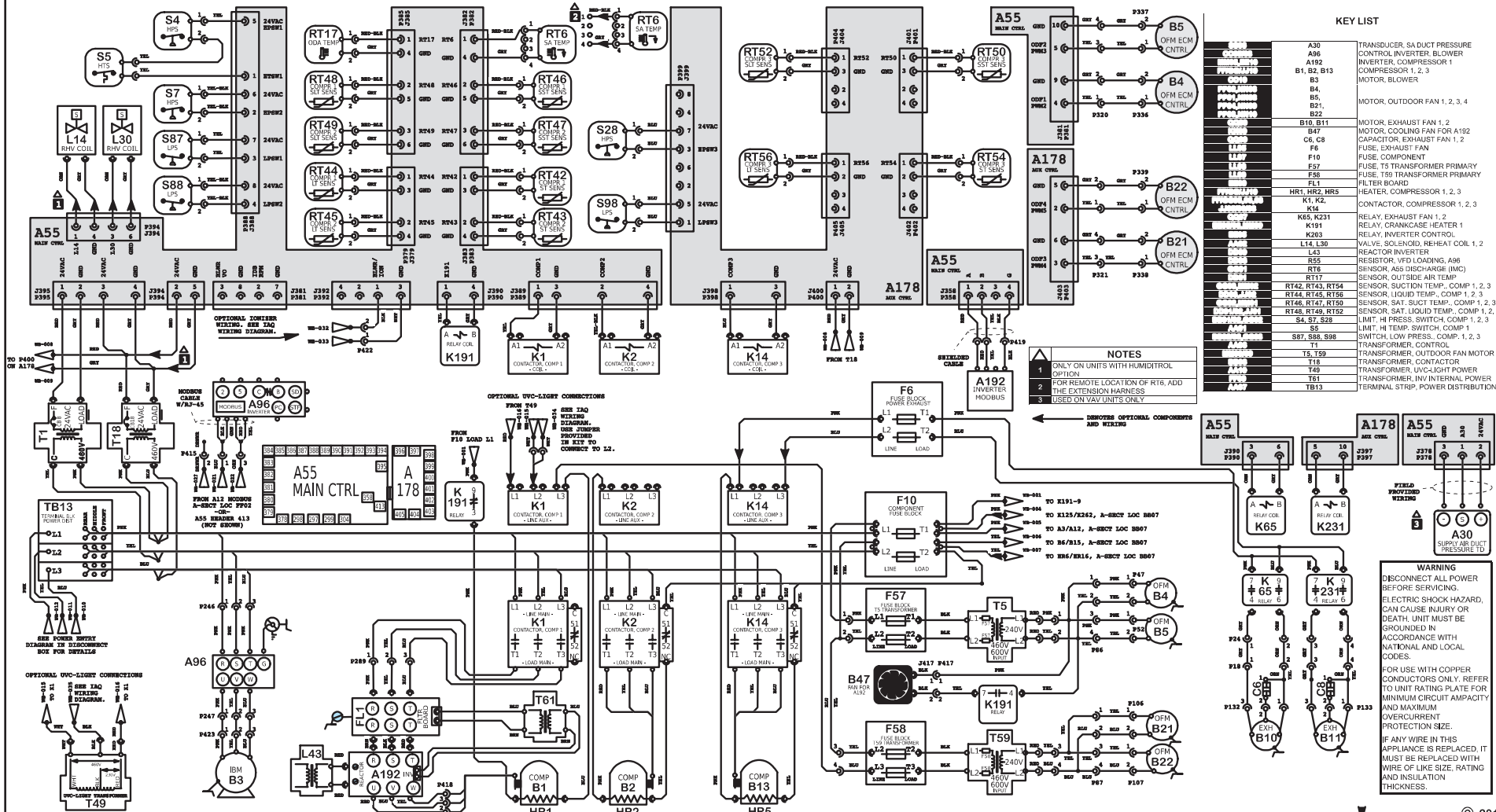
Model: LCM, LGM 156U, 180U - Y-VOLT  
 Voltage: 208-240/3/60 (Y)  
 Supersedes: N/A Form No: 538098-0 Rev: 0  
 COOLING - MSAV NO BYPASS -OR- VAV - 3 COMPRESSORS, 4 CONDENSER FANS

**WIRING DIAGRAM FLOW**

HEATING	COOLING	COOLING	ACCS	ACCS
SECT ON A	SECT ON B	SECT ON C	SECT ON C	SECT ON D

538098-0

# LGM/LCM156U/180U G Voltage No By-Pass



### KEY LIST

A30	TRANSUCER, SA DUCT PRESSURE
A96	CONTROL INVERTER, BLOWER
A192	INVERTER, COMPRESSOR 1
B1, B2, B13	COMPRESSOR 1, 2, 3
B3	MOTOR, BLOWER
B4	MOTOR, OUTDOOR FAN 1, 2, 3, 4
B5	MOTOR, OUTDOOR FAN 1, 2, 3, 4
B21	MOTOR, OUTDOOR FAN 1, 2, 3, 4
B22	MOTOR, OUTDOOR FAN 1, 2, 3, 4
B10, B11	MOTOR, EXHAUST FAN 1, 2
B47	MOTOR, COOLING FAN FOR A192
C6, C8	CAPACITOR, EXHAUST FAN 1, 2
F6	FUSE, EXHAUST FAN
F10	FUSE, COMPONENT
F57	FUSE, T3 TRANSFORMER PRIMARY
F78	FUSE, T59 TRANSFORMER PRIMARY
FL1	FILTER BOARD
HR1, HR2, HR5	HEATER, COMPRESSOR 1, 2, 3
K1, K2	CONTACTOR, COMPRESSOR 1, 2, 3
K14	RELAY, EXHAUST FAN 1, 2
K65, K231	RELAY, CRANKCASE HEATER 1
L3	REGISTOR, VFD LOADING, A96
K203	VALVE, SOLENOID, REHEAT COIL 1, 2
L14, L30	SENSOR, OUTSIDE AIR TEMP
L43	SENSOR, SUCTION TEMP, COMP 1, 2, 3
RT42, RT43, RT54	SENSOR, LIQUID TEMP., COMP 1, 2, 3
RT44, RT45, RT56	SENSOR, SAT. SUCT TEMP., COMP 1, 2, 3
RT46, RT47, RT59	SENSOR, SAT. LIQUID TEMP., COMP 1, 2, 3
RT48, RT49, RT52	LIMIT, HI PRESS. SWITCH, COMP 1, 2, 3
S4, S7, S26	LIMIT, HI TEMP. SWITCH, COMP 1, 2, 3
S5	SWITCH, LOW PRESS., COMP 1, 2, 3
S87, S88, S98	TRANSFORMER, CONTROL
T1	TRANSFORMER, OUTDOOR FAN MOTOR
T5, T59	TRANSFORMER, CONTACTOR
T18	TRANSFORMER, INV INTERNAL POWER
T49	TRANSFORMER, UV/LIGHT POWER
T61	TRANSFORMER, INV INTERNAL POWER
T813	TERMINAL STRIP, POWER DISTRIBUTION

**NOTES**  
 1 ONLY ON UNITS WITH HUMIDITROL OPTION  
 2 FOR REMOTE LOCATION OF RT6, ADD THE EXTENSION HARNESS  
 3 USED ON VAV UNITS ONLY

REMOVE OPTIONAL COMPONENTS AND WIRING

**WARNING**  
 DISCONNECT ALL POWER BEFORE SERVICING. ELECTRIC SHOCK HAZARD, CAN CAUSE INJURY OR DEATH. UNIT MUST BE GROUNDED IN ACCORDANCE WITH NATIONAL AND LOCAL CODES.  
 FOR USE WITH COPPER CONDUCTORS ONLY. REFER TO UNIT RATING PLATE FOR MINIMUM CIRCUIT AMPACITY AND MAXIMUM OVERCURRENT PROTECTION SIZE.  
 IF ANY WIRE IN THIS APPLIANCE IS REPLACED, IT MUST BE REPLACED WITH WIRE OF LIKE SIZE, RATING AND INSULATION THICKNESS.

Model: LCM, LGM 156U, 180U - G-VOLT  
 COOLING - MEAV NO BYPASS -OR- VAV - 3 COMPRESSORS, 4 CONDENSER FANS

Voltage: 460/3/60 (G)  
 Supersedes: XXXXXX-XX Form No: 538102-0 Rev: 0

WI R NG DI AGRAM FLOW

HEAT1 HS	COOLI1 HS	COOLI2 HS	ACCS	ACCS
SECT1 ON A	SECT1 ON B	SECT1 ON C	SECT1 ON D	SECT1 ON E

538102-0 © 201



### **Sequence of Operation LGM/LCM156 & 180U**

- 1 - Line voltage from TB13 energizes transformer T1 and T18. Transformer T1 and T18 provides 24VAC power to the main controller A55. The transformers also provide 24VAC power to the unit cooling, heating and blower controls and thermostat

### **ECONOMIZER OPERATION**

- 2 - The A55 Unit Controller receives a demand and energizes exhaust fan relay K65 and K231 with 24VAC at 50% (travel) outside air damper open (adjustable).
- 3 - N.O. K65-1, K65-2, K231-01 and K231-02 close, energizing exhaust fan motors B10 and B11.

### **1ST STAGE COOLING**

- 4 - First stage cooling demand energizes Y1 and G in the thermostat. G energizes blower, if blower is not already running (see step 3).
- 5 - 24VAC is routed to the A55 Unit Controller. After A55 proves N.C. low pressure switch S87 , high pressure switch S4 and high temperature limits S5 compressor contactor K1 is energized.
- 6 - N.O. contacts K1-1 close energizing compressor B1.
- 7 - A178 energizes outdoor fans B21 and B22.
- 8 - Relay K191 opens de-energizing compressor 1 crankcase heater HR1.

### **2ND STAGE COOLING**

- 9 - Second stage cooling demand energizes Y2.
- 10 - After A55 proves N.C. low pressure switch S88 and S98, and N.C. high pressure switch S7 and 228, contactors K1 and K14 are energized.
- 11 - N.O. K2 closes energizing compressor B2 and de-energizing crankcase heater HR2.
- 12 - N.O. K14 closes energizing compressor B13, de-energizing HR5.
- 13 - A178 energizes outdoor fans B4 and B5.

### **BLOWER OPERATION *With By Pass***

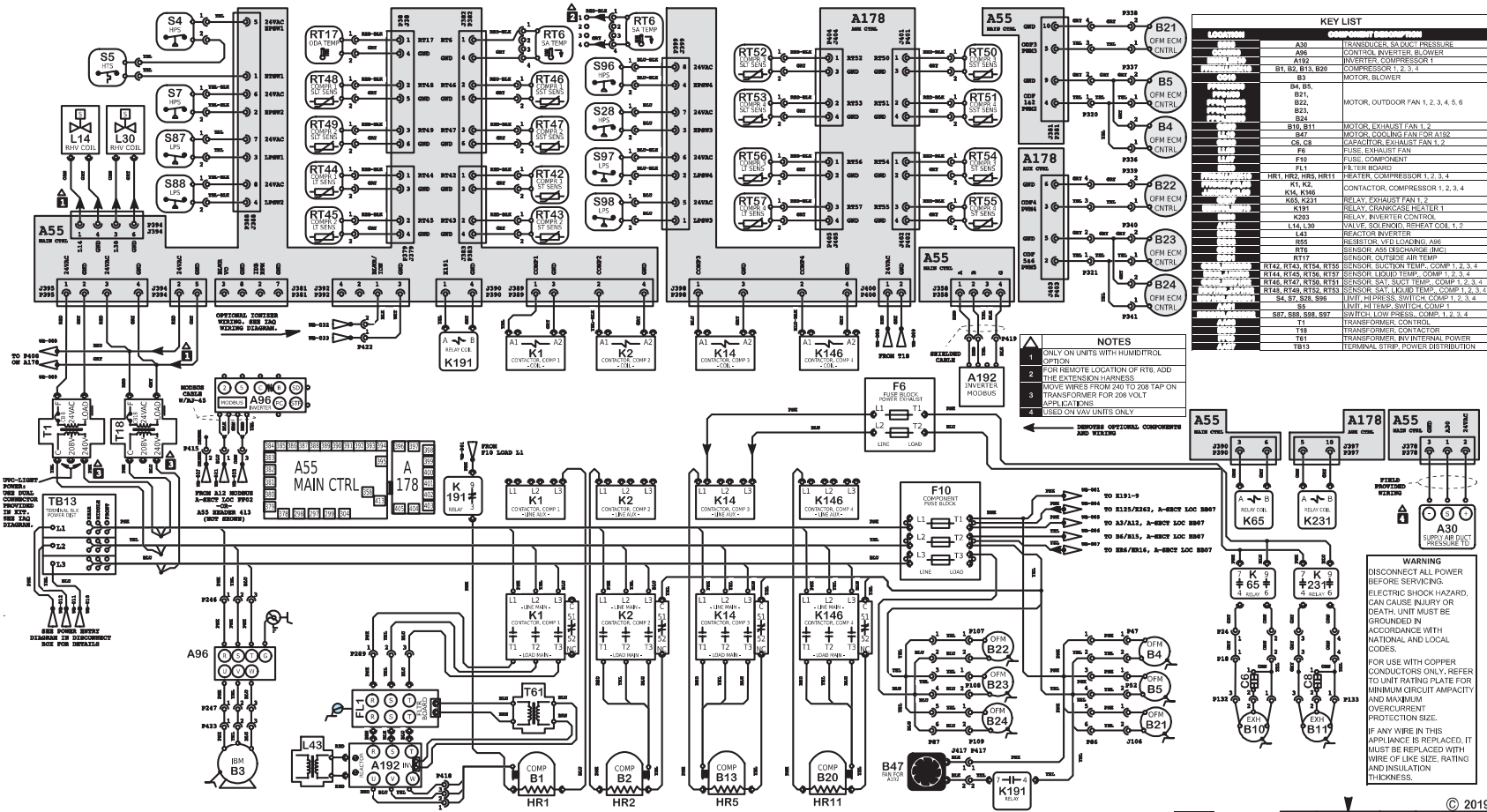
- 1 - Control inverter A96 energizes contactor K202 and main control A55 energizes relay 203.
- 2 - K203-1 N.C. contacts open to de-energize K3 relay coil. K3 contacts open to interrupt power to B3 blower motor through K3 N.O. relay contacts.
- 3 - K202 contacts close to allow power to B3 blower motor from A96.

### **BLOWER OPERATION *No By-Pass***

- 1 - Control inverter A96 energizes B3 on a G demand.



# LGM/LCM210U, 240U, 300U Y Voltage No By-Pass



KEY LIST	
A30	TRANSFORMER, 8A DUCT PRESSURE
A32	CONTROL, INVERTER, BLOWER
A32	INVERTER, COMPRESSOR 1
B1, B2, B3, B20	COMPRESSOR 1, 2, 3, 4
B4, B5	MOTOR, BLOWER
B1, B2, B3, B4	MOTOR, OUTDOOR FAN 1, 2, 3, 4, 5, 6
B10, B11	MOTOR, EXHAUST FAN 1, 2
B1	MOTOR, COOLING FAN FOR A192
C6, C8	CAPACITOR, EXHAUST FAN 1, 2
F10	FUSE, EXHAUST FAN
F19	FUSE, COMPONENT
F11	FLTER BOARD
HR1, HR2, HR5, HR11	HEATER, COMPRESSOR 1, 2, 3, 4
K1, K2	CONTACTOR, COMPRESSOR 1, 2, 3, 4
K16, K166	RELAY, EXHAUST FAN 1, 2
K65, K231	RELAY, INVERTER CONTROL
K191	RELAY, CRANKCASE HEATER 1
K200	RELAY, INVERTER CONTROL
L14, L30	VALVE, SOLID STATE, REHEAT COIL 1, 2
L43	REACTOR, INVERTER
R55	RESISTOR, VFD LOADING, AWE
R16	SENSOR, 208V DISCHARGE, BIRD
RT17	SENSOR, AIR TEMP
RT42, RT43, RT44, RT45	SENSOR, SUCTION TEMP, COMP 1, 2, 3, 4
RT44, RT45, RT46, RT47	SENSOR, LIQUID TEMP, COMP 1, 2, 3, 4
RT46, RT47, RT49, RT50	SENSOR, SAT. SUCT. TEMP, COMP 1, 2, 3, 4
RT49, RT50, RT53, RT56	SENSOR, SAT. BUBBLE TEMP, COMP 1, 2, 3, 4
S4, S7, S28, S29	LIMIT, HI PRESS. SWITCH, COMP 1, 2, 3, 4
S87, S88, S95, S97	LIMIT, HI PRESS. SWITCH, COMP 1, 2, 3, 4
T1	TRANSFORMER CONTROL
T19	TRANSFORMER, CONTACTOR
T61	TRANSFORMER, RV INTERNAL POWER
TB13	TERMINAL STRIP, POWER DISTRIBUTION

**NOTES**

- 1. ONLY ON UNITS WITH HUMIDIFROL OPTION
- 2. FOR REMOTE LOCATION OF RT6, ADD THE EXTENSION HARNESS
- 3. MOVE WIRES FROM 240 TO 208 TAP ON TRANSFORMER FOR 208 VOLT OPERATION
- 4. USED ON VAV UNITS ONLY

**WARNING**

DISCONNECT ALL POWER BEFORE SERVICING. ELECTRIC SHOCK HAZARD. CAN CAUSE INJURY OR DEATH. UNIT MUST BE GROUNDED IN ACCORDANCE WITH NATIONAL AND LOCAL CODES.

FOR USE WITH COPPER CONDUCTORS ONLY. REFER TO UNIT RATING PLATE FOR MINIMUM CIRCUIT AMPACITY AND MAXIMUM OVERCURRENT PROTECTION SIZE.

IF ANY WIRE IN THIS APPLIANCE IS REPLACED, IT MUST BE REPLACED WITH WIRE OF LIKE SIZE, RATING AND INSULATION THICKNESS.

Model: LCM, LGM 210U, 240U, 300U - Y-VOLT  
COOLING - MSAV NO BYPASS -OR- VAV - 4 COMPRESSORS, 6 CONDENSER FANS

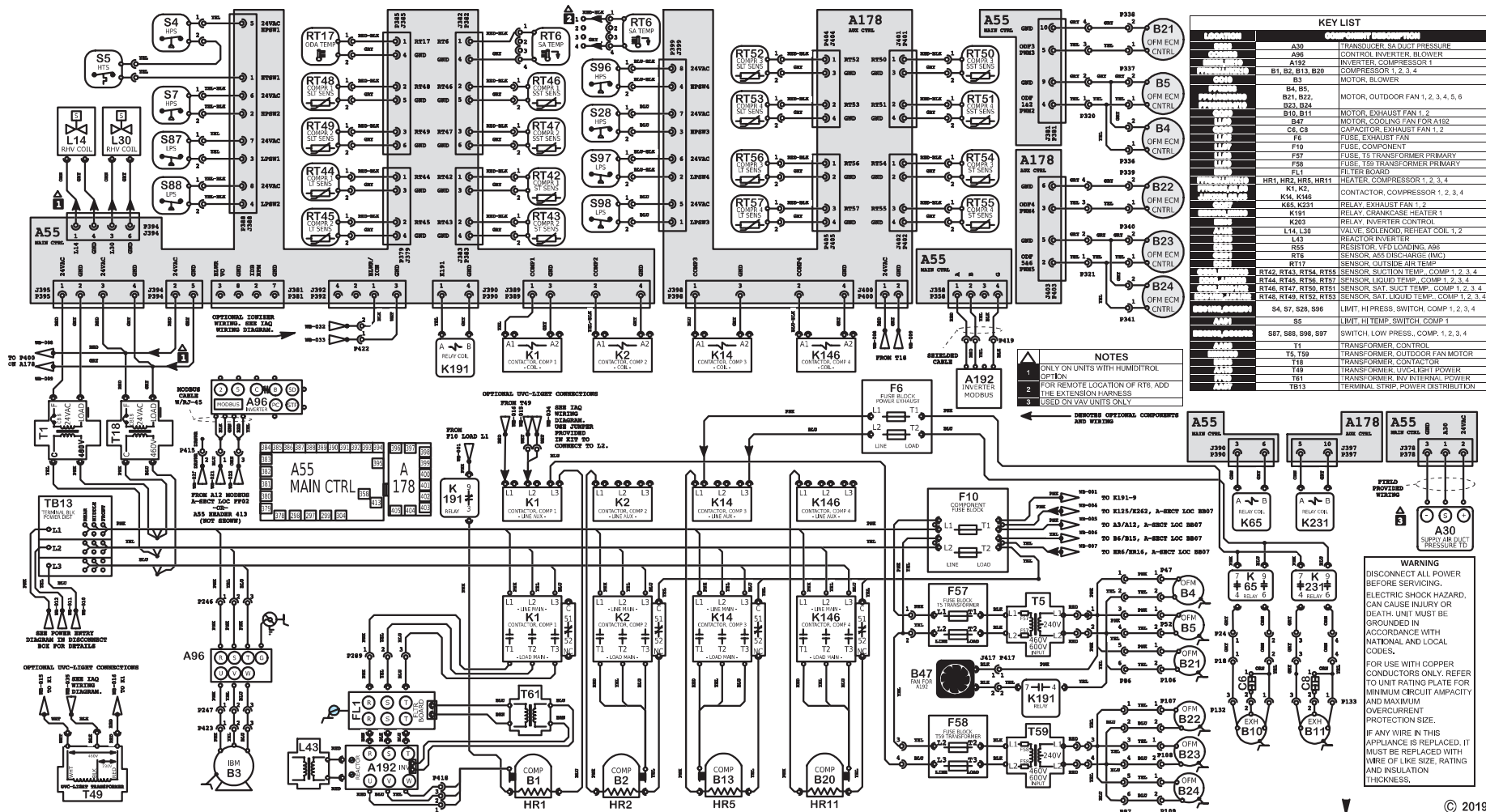
Voltage: 208-240/3/60 (Y)  
Supersedes: N/A Form No: 538096-0 Rev: 0

**WIRING DIAGRAM FLOW**

HEAT NG	COOL NG	COOL NG	ACCS	ACCS
SECTI ON A	SECTI ON B	SECTI ON C	SECTI ON D	SECTI ON E

538096-0

# LGM/LCM210U, 240U, 300U G Voltage No By-Pass



KEY LIST	
Location	Component
A30	TRANSFORMER, SAULT PRESSURE
A36	CONTROL INVERTER, BLOWER
A192	INVERTER, COMPRESSOR 1
B1, B2, B11, B20	COMPRESSOR 1, 2, 3, 4
B3	MOTOR, BLOWER
B4, B5, B7, B21, B22, B23, B24	MOTOR, OUTDOOR FAN 1, 2, 3, 4, 5, 6
B10, B11	MOTOR, EXHAUST FAN 1, 2
B97	MOTOR, COOLING FAN FOR A152
C6, C8	CAPACITOR, EXHAUST FAN 1, 2
F6	FUSE, EXHAUST FAN
F7	FUSE, COMPONENT
F57	FUSE, T5 TRANSFORMER PRIMARY
F58	FUSE, T9 TRANSFORMER PRIMARY
F11	FILTER BOARD
HR1, HR2, HRS, HR11	HEATER, COMPRESSOR 1, 2, 3, 4
K1, K2, K4, K56	CONTACTOR, COMPRESSOR 1, 2, 3, 4
K85, K231	RELAY, EXHAUST FAN 1, 2
K191	RELAY, GRANULIC HEATER 1
K203	RELAY, INVERTER CONTROL
L14, L30	VALVE, SOLENOID, REHEAT COIL 1, 2
L43	INACTOR INVERTER
R55	RESISTOR, VFD LOADING, A96
R76	SENSOR, A55 DISCHARGE (IAC)
RT17	SENSOR, OUTSIDE AIR TEMP
RT42, RT43, RT54, RT55	SENSOR, SUCTION TEMP, COMP 1, 2, 3, 4
RT44, RT45, RT56, RT57	SENSOR, LIQUID TEMP, COMP 1, 2, 3, 4
RT46, RT47, RT50, RT51	SENSOR, SAT. SUCTION TEMP, COMP 1, 2, 3, 4
RT48, RT49, RT52, RT53	SENSOR, SAT. LIQUID TEMP, COMP 1, 2, 3, 4
S4, S7, S28, S96	LIMIT, HI PRESS. SWITCH, COMP 1, 2, 3, 4
S5	LIMIT HI TEMP. SWITCH, COMP 1
S87, S88, S96, S97	SWITCH, LOW PRESS. COMP 1, 2, 3, 4
T1	TRANSFORMER CONTROL
T5, T9	TRANSFORMER, OUTDOOR FAN MOTOR
T16	TRANSFORMER, CONTACTOR
T91	TRANSFORMER, LOCK-OUT POWER
T91	TRANSFORMER, INVERTER, POWER
TB13	TERMINAL STRIP, POWER DISTRIBUTION

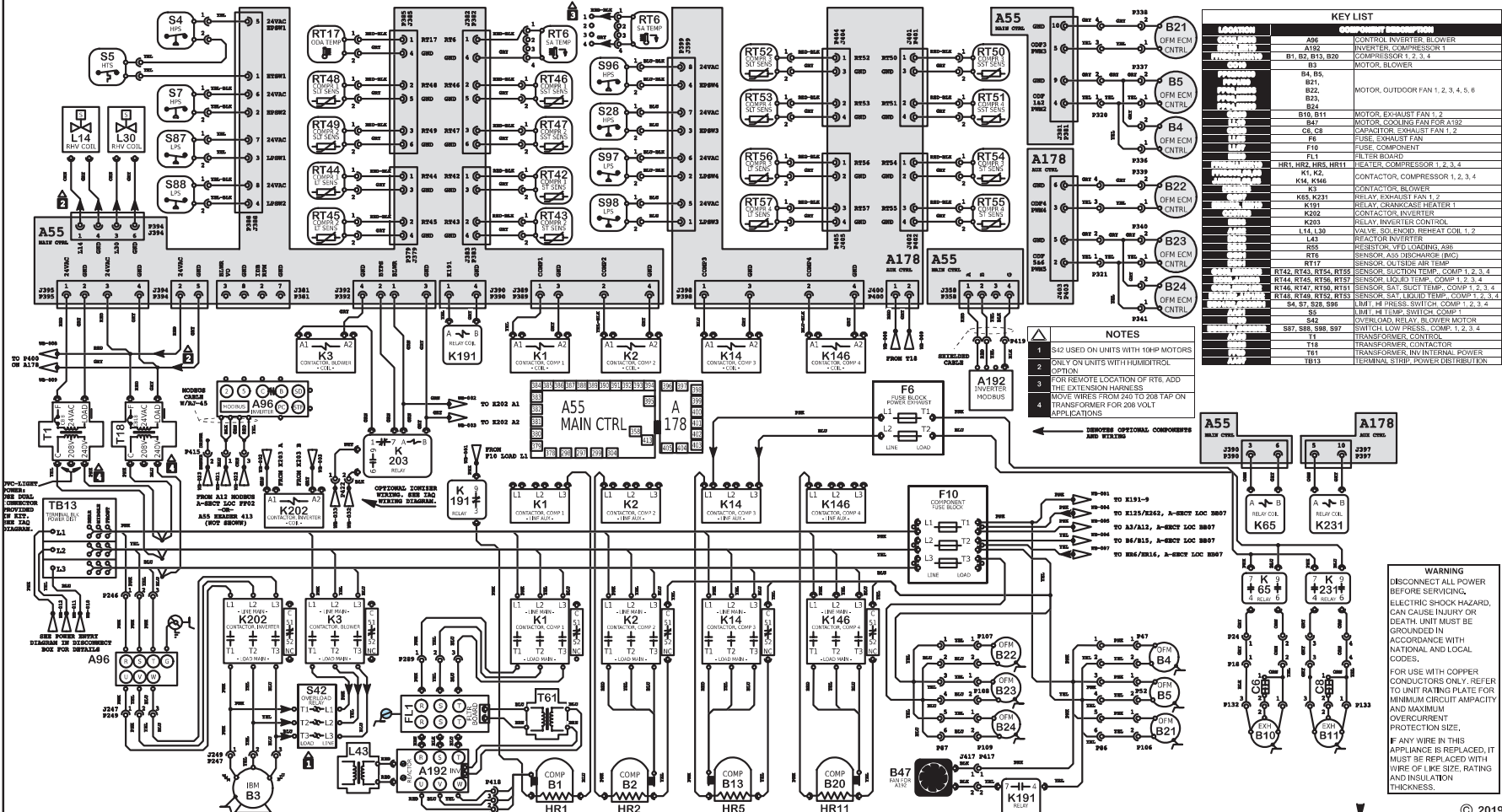
**NOTES**  
 1 ONLY ON UNITS WITH HUMIDICONTROL OPTION  
 2 FOR REMOTE LOCATION OF RT6, ADD THE EXTENSION HARNESS  
 3 USED ON VAV UNIT'S ONLY

**WARNING**  
 DISCONNECT ALL POWER BEFORE SERVICING.  
 ELECTRIC SHOCK HAZARD, CAN CAUSE INJURY OR DEATH. UNIT MUST BE GROUNDED IN ACCORDANCE WITH NATIONAL AND LOCAL CODES.  
 FOR USE WITH COPPER CONDUCTORS ONLY. REFER TO UNIT RATING PLATE FOR MINIMUM CIRCUIT AMPACITY AND MAXIMUM OVERCURRENT PROTECTION SIZE.  
 IF ANY WIRE IN THIS APPLIANCE IS REPLACED IT MUST BE REPLACED WITH WIRE OF LIKE SIZE, RATING AND INSULATION THICKNESS.

Model: LCM, LGM 210U, 240U, 300U - G-VOLT Voltage: 460/3/60 (G) Form No: 538100-0 Rev: 0  
 COOLING - MSAV NO BYPASS -OR- VAV - 4 COMPRESSORS, 6 CONDENSER FANS Supersedes: N/A

© 2019  
 WIRING DIAGRAM FLOW  
 HEATH NG SECT1 ON A  
 COOLI NG SECT1 ON B  
 COOLI NG SECT1 ON C  
 ACCS SECT1 ON D

# LGM/LCM210U, 240U, 300U Y Voltage With By-Pass



Location	Component Description
A96	CONTROL INVERTER BLOWER
A178	INVERTER COMPRESSOR 1
B1, B2, B13, B20	COMPRESSOR 1, 2, 3, 4
B3	MOTOR BLOWER
B4, B5, B21, B22, B23, B24	MOTOR, OUTDOOR FAN 1, 2, 3, 4, 5, 6
B10, B11	MOTOR, EXHAUST FAN 1, 2
B47	MOTOR, COOLING FAN FOR A192
CB, CB	CAPACITOR, EXHAUST FAN 1, 2
F6	FUSE, EXHAUST FAN
F10	FUSE COMPONENT
F11	FILTER BAND
HR1, HR2, HR5, HR11	HEATER, COMPRESSOR 1, 2, 3, 4
K1, K2, K54, K56	CONTACTOR, COMPRESSOR 1, 2, 3, 4
K3	CONTACTOR, BLOWER
K65, K231	RELAY, EXHAUST FAN 1, 2
K191	RELAY, CRANKCASE HEATER 1
K202	CONTACTOR, INVERTER
K203	RELAY, INVERTER CONTROL
L14, L30	VALVE, SOLENOID REHEAT COIL 1, 2
L43	TRACTOR INVERTER
R55	RESISTOR, V/F6 LOADING, AIR
R76	SENSOR, AS5 DISCHARGE (IMC)
RT17	SENSOR, OUTDOOR AIR TEMP
RT42, RT43, RT46, RT48	SENSOR, SUCTION TEMP, COMP 1, 2, 3, 4
RT44, RT45, RT56, RT57	SENSOR, LIQUID TEMP, COMP 1, 2, 3, 4
RT46, RT47, RT50, RT41	SENSOR, SAT. SLUIT TEMP, COMP 1, 2, 3, 4
RT48, RT49, RT52, RT53	SENSOR, SAT. LIQUID TEMP, COMP 1, 2, 3, 4
S4, S7, S28, S96	LIMIT, HI PRESS. SWITCH, COMP 1, 2, 3, 4
S42	LIMIT, HI TEMP, SWITCH, COMP 1
S47	OVERLOAD, BLOWER MOTOR
S87, S88, S90, S97	SWITCH, LOW PRESS., COMP 1, 2, 3, 4
T1	TRANSFORMER, CONTROL
T18	TRANSFORMER, CONTROL
T81	TRANSFORMER, INV INTERNAL POWER
T811	TERMINAL STRIP, POWER DISTRIBUTION

- NOTES**
- S42 USED ON UNITS WITH 10HP MOTORS ONLY ON UNITS WITH HUMIDICONTROL
  - FOR REMOVE LOCATION OF RT6, ADD THE EXTENSION HARNESS
  - MOVE WIRES FROM 240 TO 208 TAP ON TRANSFORMER FOR 208 VOLT APPLICATIONS
  - REMOVE OPTIONAL COMPONENTS AND RT12

**WARNING**  
 DISCONNECT ALL POWER BEFORE SERVICING. ELECTRIC SHOCK HAZARD. CAN CAUSE INJURY OR DEATH. UNIT MUST BE GROUNDED IN ACCORDANCE WITH NATIONAL AND LOCAL CODES.  
 FOR USE WITH COPPER CONDUCTORS ONLY. REFER TO UNIT RATING PLATE FOR MINIMUM CIRCUIT AMPACITY AND MAXIMUM OVERCURRENT PROTECTION SIZE.  
 IF ANY WIRE IN THIS APPLIANCE IS REPLACED, IT MUST BE REPLACED WITH WIRE OF LIKE SIZE, RATING AND INSULATION THICKNESS.

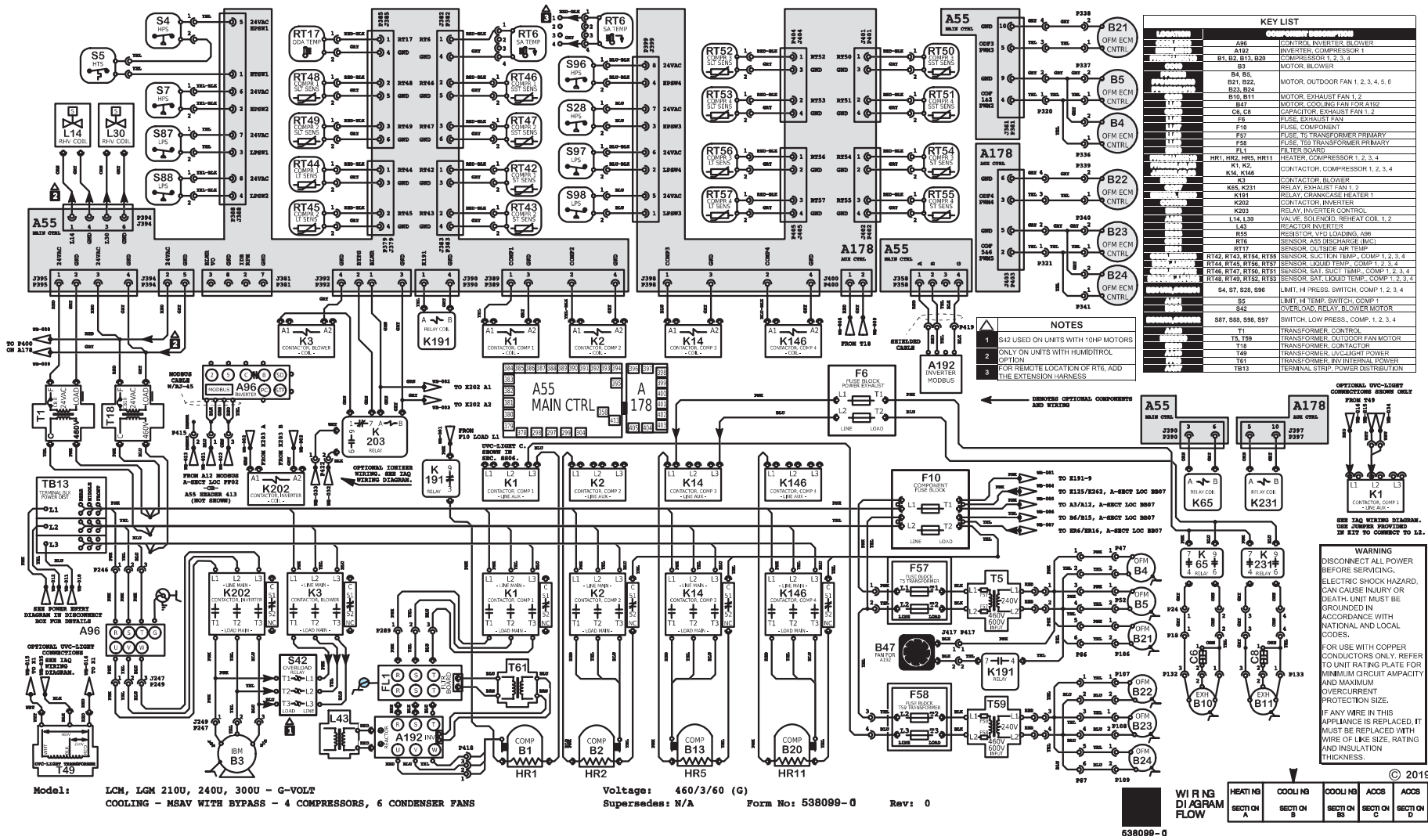
Model: LCM, LGM 210U, 240U, 300U - Y-VOLT  
 COOLING - MSAV WITH BYPASS - 4 COMPRESSORS, 6 CONDENSER FANS

Voltage: 208-240/3/60 (Y)  
 Supersedes: N/A Form No: 538095-0 Rev: 0

538095-01

WI R I N G	HEATI NG	COOLI NG	COOLI NG	ACCS	ACCS
DI AGRAM	SECTI ON	SECTI ON	SECTI ON	SECTI ON	SECTI ON
FLOW	A	B	C	D	D

# LGM/LCM210U, 240U, 300U G Voltage With By-Pass



KEY LIST	
A55	MAIN CONTROL BOARD
A178	INVERTER CONTROL BOARD
B1, B2, B3, B4, B5	MOTOR BLOWER
B21, B22, B23, B24	MOTOR, OUTDOOR FAN 1, 2, 3, 4, 5, 6
B10, B11	MOTOR EXHAUST FAN 1, 2
B47	MOTOR COOLING FAN FOR A182
C6, C8	CAPACITOR EXHAUST FAN 1, 2
F5	FUSE EXHAUST FAN
F10	FUSE COMPONENT
F57	FUSE T59 TRANSFORMER PRIMARY
F18	FUSE T59 TRANSFORMER PRIMARY
F2	FUSE BOARD
HR1, HR2, HR5, HR11	HEATER COMPRESSOR 1, 2, 3, 4
K1, K2	CONTACTOR COMPRESSOR 1, 2, 3, 4
K3	CONTACTOR BLOWER
K181	RELAY TRANSFORMER HEATER 1
K202	CONTACTOR INVERTER
K203	RELAY INVERTER CONTROL
L14, L30	VALVE SOLENOID REHEAT COIL 1, 2
L43	REACTOR INVERTER
R55	RESISTOR VFD LOADING A55
RT6	SENSOR A55 DISCHARGE (IAC)
RT17	SENSOR OUTSIDE AIR TEMP
RT42, RT43, RT44, RT45	SENSOR SUCTION TEMP, COMP 1, 2, 3, 4
RT46, RT47, RT48, RT49	SENSOR LIQUID TEMP, COMP 1, 2, 3, 4
RT48, RT49, RT52, RT53	SENSOR SAT. LIQUID TEMP, COMP 1, 2, 3, 4
S4, S7, S28, S86	LIMIT HP PRESS. SWITCH COMP 1, 2, 3, 4
S87	OVERLOAD RELAY BLOWER MOTOR
S87, S88, S98, S97	SWITCH LOW PRESS., COMP 1, 2, 3, 4
T1	TRANSFORMER CONTROL
T5, T9	TRANSFORMER OUTDOOR FAN MOTOR
T18	TRANSFORMER CONTACTOR
T49	TRANSFORMER OVERCATCH POWER
T51	TRANSFORMER OVERCATCH POWER
TB13	TERMINAL STRIP POWER DISTRIBUTION

**NOTES**

- S42 USED ON UNITS WITH 10HP MOTORS
- ONLY ON UNITS WITH HUMIDTROL OPTION
- FOR REMOTE LOCATION OF RT6, ADD THE EXTENSION HARNESS

REMOVE OPTIONAL COMPONENTS AND WIRING

**WARNING**  
DISCONNECT ALL POWER BEFORE SERVICING.  
ELECTRIC SHOCK HAZARD. CAN CAUSE INJURY OR DEATH. UNIT MUST BE GROUNDED IN ACCORDANCE WITH NATIONAL AND LOCAL CODES.  
FOR USE WITH COPPER CONDUCTORS ONLY. REFER TO UNIT RATINGS PLATE FOR MINIMUM CIRCUIT AMPACITY AND MAXIMUM OVERCURRENT PROTECTION SIZE.  
IF ANY WIRE IN THIS APPLIANCE IS REPLACED, IT MUST BE REPLACED WITH WIRE OF LIKE SIZE, RATING AND INSULATION THICKNESS.

Model: LCM, LGM 210U, 240U, 300U - G-VOLT  
COOLING - MSAV WITH BYPASS - 4 COMPRESSORS, 6 CONDENSER FANS

Voltage: 460/3/60 (G)  
Supersedes: N/A Form No: 538099-0 Rev: 0

WIRING DIAGRAM FLOW  
HEATING SECT A COOLING SECT B COOLING SECT C ACCS SECT D ACCS SECT E  
538099-0 © 2019