

MAGNITUDE[®] WME-C

MAGNETIC BEARING CENTRIFUGAL CHILLERS

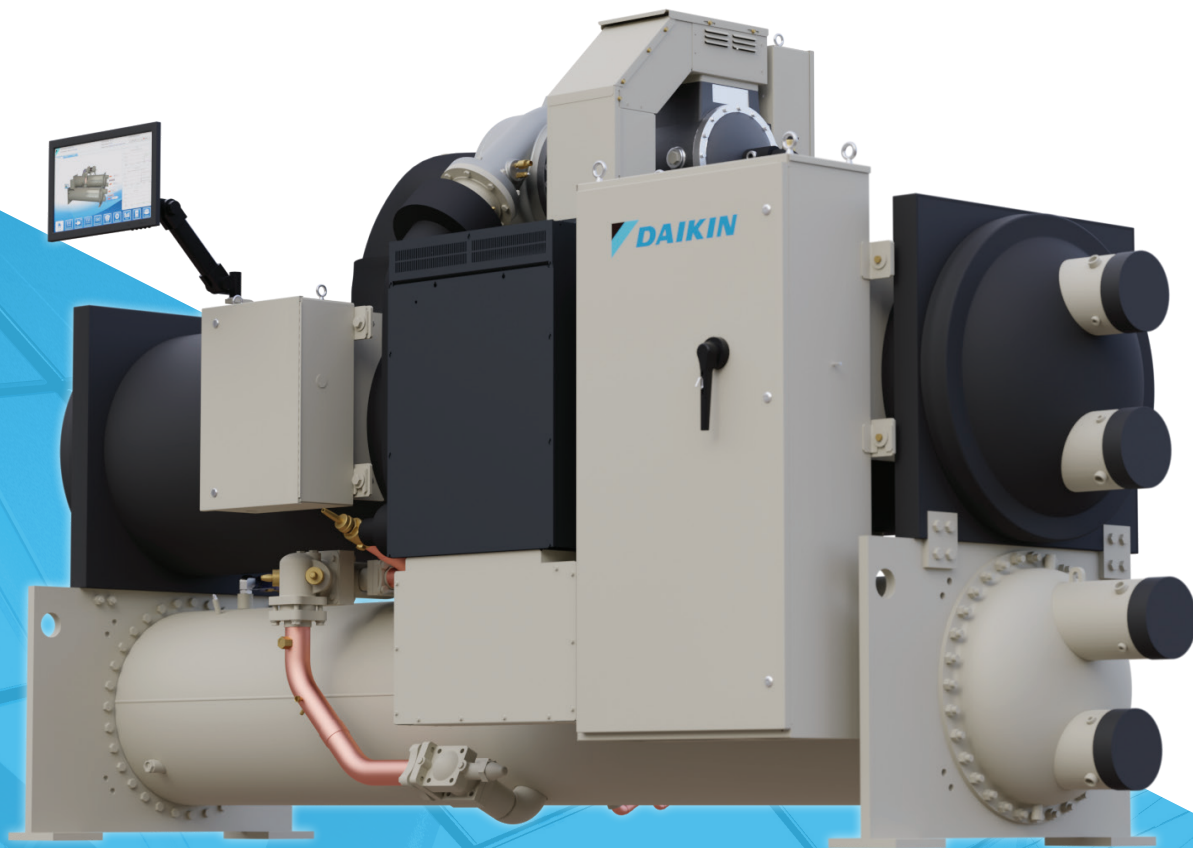

- MODEL WME-C
- 400 TO 1600 TONS
- R-134a, R-513A, OR R-515B REFRIGERANT

Introduction	3	Condenser Water Temperature Control	27
Hazard Identification	3	Human Machine Interface (HMI)	28
General Description	4	SET Screens	32
The Control System	5	Alarms	41
Operating Limits	5	Controller Inputs and Outputs	43
Installation	6	Building Automation Systems (BAS)	45
Nameplates	6	Use with On-Site Generators	45
Receiving and Handling	6	Startup and Maintenance	46
Location	6	Pre-Startup	46
Clearance	6	Flow Switch Installation and Calibration	46
Mounting	6	Mounting	46
Lifting Guidance	7	Chiller Maintenance	50
Transit and Temporary Storage	8	Seasonal Shutdown	50
Long Term Storage	8	Harmonic Filter Evaluation	50
Unit Dimensions and Shipping Weight	10	Maintenance Schedule	51
Retrofit Knockdown	11	Appendix	52
Water Piping	17	Temperature/Pressure Chart	52
Field Insulation	18	Pre-Start Checklist	53
Relief Valves	19	Limited Product Warranty	54
Electrical	21		
Field Power Wiring	21		
Chiller Control Power	21		
Operation	25		
Operator Responsibilities	25		
Operator Schools	25		
Sequence of Unit Operation	25		
Unit Enabling/Disabling and Overrides	26		



©2024 Daikin Applied, Minneapolis, MN. All rights reserved throughout the world. This document contains the most current product information as of this printing. Daikin Applied Americas Inc. has the right to change the information, design, and construction of the product represented within the document without prior notice. For the most up-to-date product information, please go to www.DaikinApplied.com.

™@ Magnitude, MicroTech, SiteLine, and Daikin Applied are trademarks or registered trademarks of Daikin Applied Americas Inc. The following are trademarks or registered trademarks of their respective companies: BACnet from American Society of Heating, Refrigerating and Air-Conditioning Engineers, Inc.; Echelon, LonWorks, LonMark, and LonTalk from Echelon Corporation; Modbus from Schneider Electric; and Windows from Microsoft Corporation.

Introduction

This manual provides installation, operation, and maintenance information for Daikin Applied Magnitude WME-C Magnetic Bearing Chiller with a MicroTech® controller.

NOTE: Installation and maintenance are to be performed only by licensed, if required by local codes and regulations, or qualified personnel who are familiar with local codes and regulations and are experienced with this type of equipment.

DANGER

LOCKOUT/TAGOUT all power sources prior to service, pressurizing, depressurizing, or powering down the unit. Failure to follow this warning exactly can result in serious injury or death. Disconnect electrical power before servicing the equipment. More than one disconnect may be required to deenergize the unit. Be sure to read and understand the installation, operation, and service instructions within this manual.

WARNING

Electric shock hazard. Improper handling of this equipment can cause personal injury or equipment damage. This equipment must be properly grounded. Connections to and service of the MicroTech control panel must be performed only by personnel that are knowledgeable in the operation of the equipment being controlled.

WARNING

Polyolester Oil, commonly known as POE oil is a synthetic oil used in many refrigeration systems, and may be present in this Daikin Applied product. POE oil, if ever in contact with PVC/CPVC, will coat the inside wall of PVC/CPVC pipe causing environmental stress fractures. Although there is no PVC/CPVC piping in this product, please keep this in mind when selecting piping materials for your application, as system failure and property damage could result. Refer to the pipe manufacturer's recommendations to determine suitable applications of the pipe.

CAUTION

Static sensitive components. A static discharge while handling electronic circuit boards can cause damage to the components. Discharge any static electrical charge by touching the bare metal inside the control panel before performing any service work. Never unplug any cables, circuit board terminal blocks, or power plugs while power is applied to the panel.

Hazard Identification

DANGER

Danger indicates a hazardous situation, which will result in death or serious injury if not avoided.

WARNING

Warning indicates a potentially hazardous situations, which can result in property damage, personal injury, or death if not avoided.

CAUTION

Caution indicates a potentially hazardous situations, which can result in minor injury or equipment damage if not avoided.

NOTICE

Notice indicates practices not related to physical injury.

NOTE: Indicates important details or clarifying statements for information presented.

General Description

Daikin Applied Magnitude® Centrifugal Chillers are complete, self-contained, automatically controlled, liquid-chilling units featuring oil-free, magnetic bearing compressors. All Magnitude chillers are equipped with a single evaporator and a single condenser along with either one or two compressors depending on the model.

Magnitude chillers are designed for indoor, non-freezing installation only. The chillers use refrigerant R-134a, R-513A, or R-515B that operates at a positive pressure over the entire operation range, so no purge system is required.

Only normal field connections such as water piping, relief valve piping, electric power, and control interlocks are required, thereby simplifying installation and increasing reliability. Necessary equipment protection and operating controls are included.

All Daikin Applied centrifugal chillers must be commissioned by a factory-trained Daikin Applied service technician. Failure to follow this startup procedure can affect the equipment warranty.

The standard limited warranty on this equipment covers parts that prove defective in material or workmanship. Specific details of this warranty can be found in the warranty statement furnished with the equipment.

Nomenclature

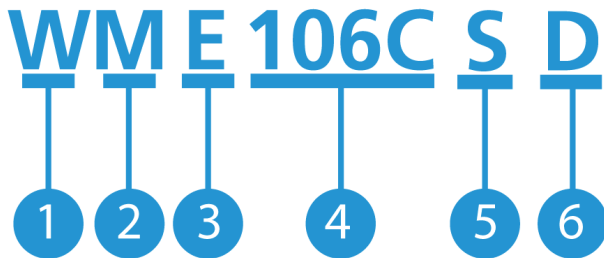

No.	Description
1	W = Water-cooled
2	M = Magnetic Bearing
3	E = Centrifugal Compressor
4	Model Code
5	S = Single D = Dual
6	Design Vintage

The Control System

Figure 1: Human Machine Interface (HMI)

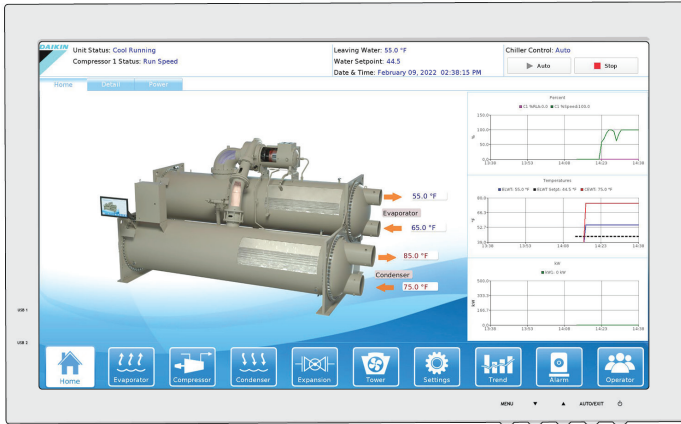

The MicroTech control system consists of a Human Machine Interface (HMI), a microprocessor-based unit controller, and compressor on-board controllers providing monitoring and control functions required for efficient chiller operation.

The MicroTech controllers acquire and process data related to chiller operation, issue instructions to various components of the chiller, and maintain controlled operation of the chiller. As a part of operating the chiller successfully, the unit controller offers necessary condenser water control.

The MicroTech unit controller also communicates with the HMI for graphic display and is located in the unit control panel. The on-board compressor controllers are located in each compressor control panel.

A single HMI is used per unit. The HMI panel is mounted on a moveable arm to allow placement in a convenient position for the operator. The HMI is the device used for viewing unit information and entering setpoints into the control system. Select information from the HMI panel can be downloaded via a USB port. For more information on the HMI, see "Human Machine Interface (HMI)" on page 24.

Operating Limits

Table 1: Operating/Standby Limits

Acceptable Temperatures (WME) ¹			R-134a and R-515B		R-513A	
Condition	Component	Description	Min Temp °F (°C)	Max Temp °F (°C)	Min Temp °F (°C)	Max Temp °F (°C)
Standby	Evaporator	Water	38 (3.3)	115 (46)	38 (3.3)	112 (44.4)
		Water w/ Antifreeze ²	30 (-1.1)	115 (46.1)	30 (-1.1)	112 (44.4)
	Equipment Room	Air w/ Water in Vessels ⁴	40 (4.4)	104 (40)	40 (4.4)	104 (40)
		Air w/ no Water in Vessels ⁴	0 (-17.7)	113 (45)	0 (-17.7)	113 (45)
Startup	Evaporator	Water	38 (3.3)	85 (29.4)	38 (3.3)	80 (26.6)
		Water w/ Antifreeze ²	30 (-1.1)	85 (29.4)	30 (-1.1)	80 (26.6)
	Condenser	Water	40 (4.4)	100 (38)	40 (4.4)	100 (37.7)
	Equipment Room	Air ⁴	40 (4.4)	104 (40)	40 (4.4)	104 (40)
Operating	Evaporator	Entering Water	38 (3.3)	85 (29.4)	38 (3.3)	80 (26.6)
		Leaving Water ³	38 (3.3)	70 (21.1)	38 (3.3)	70 (21.1)
		Entering Water w/ Antifreeze ²	30 (-1.1)	85 (29.4)	30 (-1.1)	80 (26.6)
		Leaving Water w/ Antifreeze ^{2,3}	30 (-1.1)	70 (21.1)	30 (-1.1)	70 (21.1)
	Condenser	Entering Water	40 (4.4)	100 (37.7)	40 (4.4)	100 (38)
		Leaving Water ³	45 (7.2)	111 (43.9)	45 (7.2)	111 (43.9)
	Equipment Room	Air ⁴	40 (4.4)	104 (40)	40 (4.4)	104 (40)

NOTES:

- 1 Contact a Daikin Applied representative for performance at specific operating conditions, as some limits depend on unit configuration
- 2 Antifreeze temperature limits must have appropriate glycol concentration
- 3 Allowable leaving fluid temperatures depend on Saturation Temperature
- 4 5%-95% relative humidity, non-condensing

Installation

Nameplates

There are several identification nameplates on the chiller:

- The unit nameplate is located on the exterior of the Unit Control Panel. Both the Model No. and Serial No. are located on the unit nameplate; the Serial No. is unique to the unit. These numbers should be used to identify the unit for service, parts, or warranty questions. This plate also has the unit refrigerant charge and electrical ratings.
- Vessel nameplates are located on the evaporator and condenser. They have a National Board Number (NB) and a serial number, either of which identify the vessel (but not the entire unit).

Receiving and Handling

The unit should be inspected immediately after receipt for possible damage. All Daikin Applied centrifugal water chillers are shipped FOB factory and all claims for handling and shipping damage are the responsibility of the consignee.

On units with factory-installed insulation, the insulation is removed from the vessel lifting hole (also used for transportation tie-downs) locations and is shipped loose. It should be secured in place after the unit is finally placed. Neoprene vibration isolation pads are shipped loose in the power panel. If the unit is equipped with a shipping skid, leave the skid in place until the unit is in its final position. This will aid in handling the equipment.

 CAUTION
Extreme care must be used when rigging the unit to prevent damage to the control panels and refrigerant piping. See the certified dimension drawings included in the job submittal for the weights and center of gravity of the unit. If the drawings are not available, consult the local Daikin Applied sales office for assistance.

Location

WME chillers are intended only for installation in an indoor or weather protected area consistent with the NEMA 1 rating on the chiller, controls, and electrical panels. Equipment room temperature for operating and standby conditions is 40°F to 104°F (4.4°C to 40°C).

NOTICE
Indoor installations must be in a structure with a permanent floor and roof. The unit must be enclosed by walls for protection from weather conditions.

Excessive humidity in the mechanical room should be avoided. A limit of 90% non-condensing humidity should be met to minimize electrical components exposure to water condensing in panels. Humidity levels in the mechanical room, even if lower than 90%, can cause water to condense on/near all cool surfaces and potentially lead to premature component wear. If possible, the mechanical room should be conditioned which can extend the

useful lifetime for all mechanical room equipment.

NOTICE
Radiant heat from boilers or piping that would adversely raise component surface temperatures beyond ambient limits must also be avoided.

 DANGER
Prevent lint, paper fibers, dust, metallic chips, or other foreign material from getting into the inverter or accumulating on VFD cooling outlets, the heat sink, circuit boards, control panels, or other electrical devices. Failure to do so may affect operation of the VFD, void warranty, result in a fire, unit damage, property damage, severe personal injury, or death. Frequently inspect area around inverter, heatsink, and other electrical devices to ensure they are free of foreign material.

Clearance

The unit must be placed in an area that allows for adequate clearance around the unit. See [Figure 5](#) for clearance requirements around the sides of the chiller. Doors and removable wall sections can be utilized to meet these clearance requirements. There must be a minimum 3-foot clearance above the top of the chiller. The U.S. National Electrical Code® (NEC) or local codes can require more clearance in and around electrical components and must be checked for compliance.

Mounting

The unit must be mounted on a concrete or steel base. Make sure that the floor or structural support is adequate to support the full operating weight of the complete unit.

The neoprene vibration pads (shipped loose in the power panel) should be placed under the corners of the unit (unless the job specifications state otherwise). They must be installed so that they are flush with the edges of the unit feet.

It is not necessary to bolt the unit to the mounting slab or framework. Should this be required by local codes, 1-1/8 inch (1.125 inch, 28.5 mm) mounting holes are provided in the unit supports at the four corners. When mounted, the base pad of the unit must be level to within ± 1/2 inch (0.5 inch, 12.7 mm) across the length and width of the unit.

Lifting Guidance

Daikin Applied equipment is designed to withstand the loads of the lifting and rigging process resulting from ASME Standard P30.1 - Planning for Load Handling Activities or equivalent. Lifting guidance is intended for installations of newly delivered equipment. If moving previously installed equipment for re-location or disposal, consideration should be given to unit condition. Equipment should also be drained as unit weight and center of gravity values do not reflect the addition of water for lifting.

⚠ DANGER

Improper rigging, lifting, or moving of a unit can result in unit damage, property damage, severe personal injury or death. See the as-designed, certified dimensioned drawings included in the job submittal for the weights and center of gravity of the unit. If the drawings are not available, consult the local Daikin Applied sales office for assistance.

Installation is to be performed only by qualified personnel who are familiar with local codes and regulations, and experienced with this type of equipment. Lifting equipment and mechanisms must be determined by the Lifting Director per the current version of ASME Standard P30.1 or equivalent and must be suited for the load capacity. Daikin Applied is not a licensed nor certified rigging specialist. Therefore it is the customer's responsibility to consult a certified rigging contractor to rig, lift, and move components and subcomponents properly and safely as needed.

⚠ CAUTION

Forklifts may not be used to lift or move Magnitude units as the method may result in unit damage.

⚠ CAUTION

When around sharp edges, wear appropriate Personal Protective Equipment (PPE), such as gloves, protective clothing, foot wear, eye protection, etc. to prevent personal injury.

Lifting Brackets

Lifting bracket designs vary from product to product. Rules of engagement with the lifting brackets are the same regardless of the bracket type. For Magnitude units, a typical lifting bracket with 2" (51 mm) diameter holes found on the sides of the unit base are illustrated in Figure 2. See the as-designed certified drawings for specific lifting points on this product model.

Engagement with each lifting hole is to be as close to vertical as possible. The maximum allowable lift angle from the vertical is 30° as shown in Figure 3. If the lift angle shifts beyond 30° from vertical on any of the lift points, the lift shall not proceed until a plan and rigging can be secured that will correct the angle of lift.

⚠ WARNING

The lifting angle must not go beyond 30 degrees from vertical or the unit can become unstable which may result in unit damage, property damage, severe personal injury, or death.

Figure 2: Illustration of Lifting Bracket and Allowed Angle for Lifting

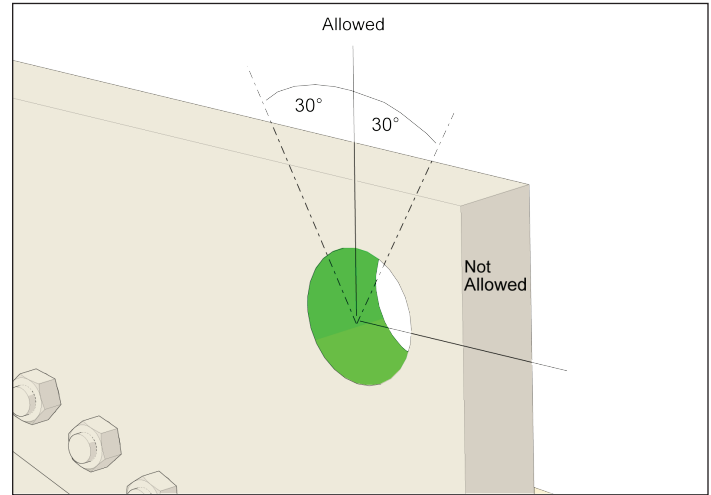

Figure 3: Illustration of Allowed Angle Label

⚠ WARNING

All factory provided lifting points must be used. Unit must remain level during lift and transit!

The lifting and tie-down angle must not go beyond 30 degrees from vertical or the unit can become unstable which may result in unit damage, property damage or severe personal injury or death.

Lifting Equipment

Lifting equipment is supplied by the user or their designate. This is typically selected around the unit certified information of the equipment to be lifted and the available lifting equipment planned to be at the site where the lift is to take place. It is the responsibility of the Lifting Director to follow a standard practice of lift planning and equipment selection, like that found in the ASME P30 series of standards. Lifting plan and equipment must ensure that the only contact with the unit is at the lifting brackets. Straps, chains or spreader bars that are likely to be used shall not come in contact with the unit.

⚠ CAUTION

Lifting mechanisms must not make contact with the unit beyond the lifting bracket. Extreme care must be used when rigging the unit to prevent damage to the control panels, unit handles, unit piping, and unit frame.

Lifting Points

Lifting points are predetermined by design. When lifting, all factory installed lifting brackets must be used. Figure 4 illustrates typical 8 point lifting configuration, with four lifting points on each side of the unit. The unit must remain level throughout the entire lifting event. Level is defined as one end being no more than 0.25" per foot of unit length to the opposite end.

WARNING

Be aware that the center of gravity may not necessarily be in the geometric center of the unit. No additional items can be added to a lift with the unit as it may affect the center of gravity and cause unit damage, property damage, severe personal injury or death. Refer to as-designed, certified drawings for weight, center of gravity location and details specific to unit configuration.

Figure 4: Lifting Points Locations

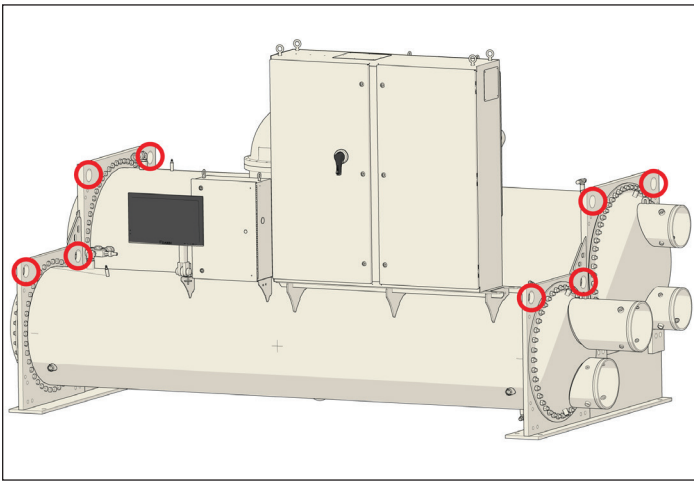

Transit and Temporary Storage

If the unit is stored for an intermediate period before installation or moved to a different location, take these additional precautions:

1. Support the unit well along the length of the base rail.
2. Level the unit (no twists or uneven ground surface).
3. Provide proper drainage around the unit to prevent flooding of the equipment.
4. Provide adequate protection from vandalism, mechanical contact, etc.
5. Securely close the doors and lock the handles.
6. Long term storage in humid environments may cause condensate corrosion on steel surfaces. Consider adding a desiccant material to alleviate corrosion concerns.

When the unit is being tied down for transit, the maximum allowable attachment angle from the vertical is 30 degrees in the opposite direction of lifting in Figure 3. Shimming of the unit under the lifting brackets or tie-down points must be used to ensure even contact along the length of the base rail.

Long Term Storage

This information applies to new units being stored waiting for startup or existing units that may be inoperative or in storage for four months or more.

The chiller must be stored in a secure, dry location and protected from any damage or sources of corrosion while in storage. A Daikin Applied service representative must perform a leak test and visual inspection for any damage or unusual conditions affecting the unit on a minimum quarterly schedule, to be paid by the owner or contractor. Daikin Applied will not be responsible for any refrigerant loss during the storage time, for repairs to the unit during the storage period, or while moving the unit from the original location to a storage facility and back to any new installation location. If there is concern about the possibilities of damage and loss of charge during storage, the customer can have the charge removed and stored in recovery cylinders.

CAUTION

If the ambient temperature of the storage location is expected to exceed 130°F (54.4°C), then the refrigerant must be removed.

It is necessary to observe some precautions during storage.

- Do not leave the unit exposed to weather elements
- Do not expose the unit to direct sunlight
- Do not keep the machine near a heat source and/or open flame
- Humid environments may cause condensate corrosion on steel surfaces. Consider adding a desiccant material to alleviate corrosion concerns
- Keep in places where ambient temperature is between + 41°F (5°C) to 130°F (54.4°C). Room temperature over the maximum limit may trigger the relief valve resulting in loss of refrigerant

For additional tasks required, contact a Daikin Applied service representative.

Figure 5: Minimum Clearances Based on Standard Waterboxes

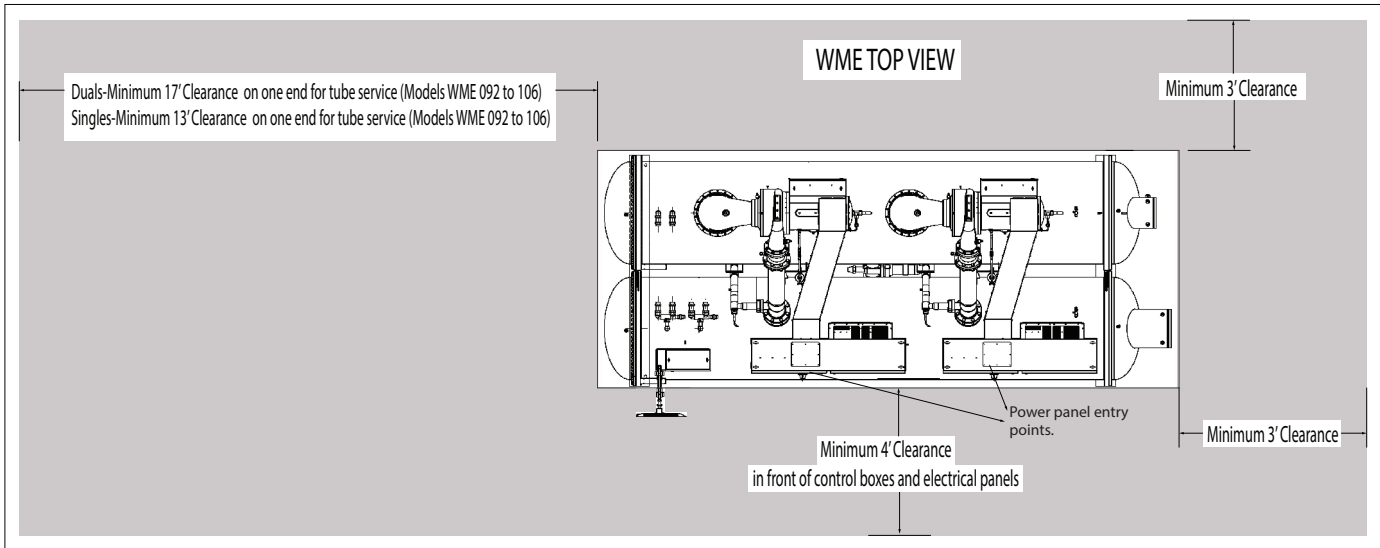

Drawing Notes

- Final connections must allow for +/- 1/2 inch (0.5 inch, 12.7 mm) manufacturing tolerances.
- 1.00-inch FPT (25.4 mm) evaporator and condenser relief valves must be piped per ANSI/ASHRAE 15.
- Minimum Clearances (See Figure 5)
- Check local codes for any additional clearance requirements.
- Installation layout should be designed by qualified personnel familiar with local codes.
- Hinged type waterboxes may require more clearance. Consult a Daikin Applied representative for details.
- Unit shown has standard right-hand water connections. Left-hand connections are available for either vessel. ANSI-flanged nozzle connections are available upon request. When using ANSI-flanged connections, add 0.5 inch (13 mm) to each flanged end.
- Dimensions shown are for units (evaporator/condenser) with standard design pressures. The waterside design pressure is 150 psi (1034 kPa). Consult the factory for unit dimensions with higher design pressures.
- Unit vibration isolator pads are provided for field installation and when fully loaded are 0.25 inches (6 mm) thick.
- 3.25-inch (83 mm) diameter lifting holes are provided. See [Figure 2](#) for lifting details.
- The shipping skid adds 4.00 inches (105 mm) to the overall unit height.
- If main power wiring is brought up through the floor, this wiring must be outside the envelope of the unit.
- The unit is shipped with a full operating charge of refrigerant except with the "Partial Disassembly" knockdown option.
- Power landing panel is on top of the cabinet. Multiple point power will have two separate landing panels.
- Units with single point power, 575V, and/or the optional harmonic filter will require additional panels.

Unit Dimensions and Shipping Weight

NOTICE

Drawings, dimensional values, and other information may change depending on options or configurations selected. Refer to the as-built submittal drawings provided by a Daikin Applied sales representative for configuration-specific details.

Figure 6: Representative WME Dimensional Drawing

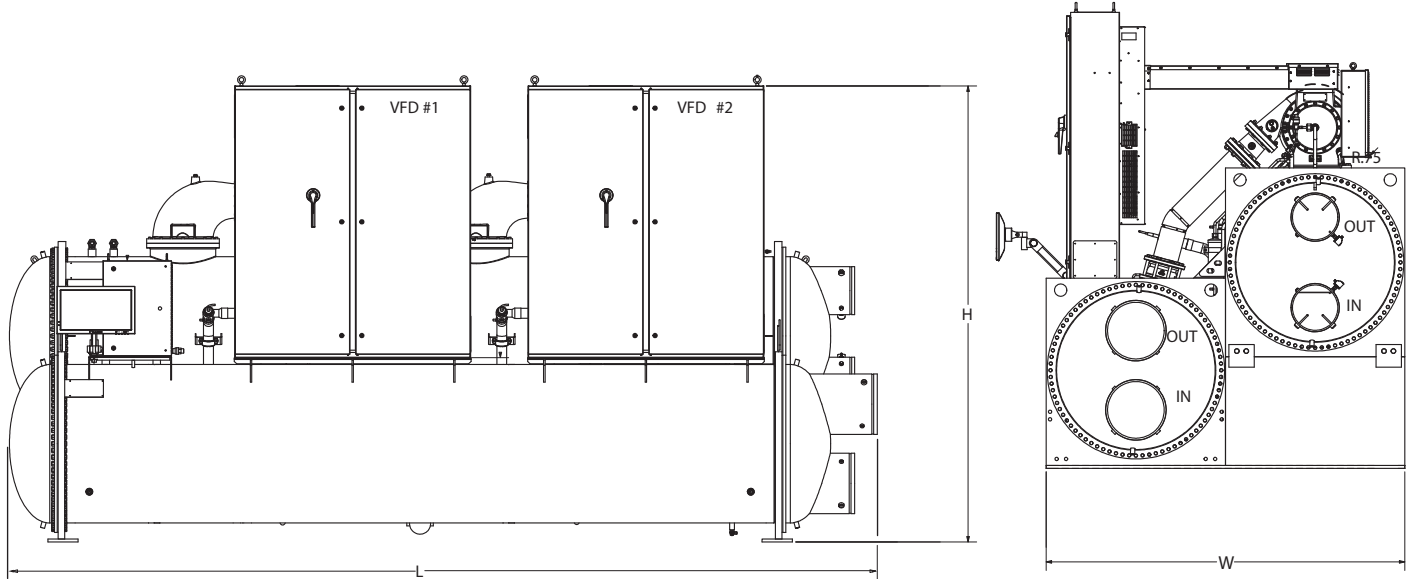

Table 2: WME Overall Dimensions

Model ¹	Heat Exchanger	Dished Waterbox Heads Length ² in. (mm)	Marine Waterbox Heads Length ² in. (mm)	Width in. (mm)	Height ³ in. (mm)
WME092*S	E3012 / C2612	170.58 (4332)	188.46 (4787)	69.10 (1755)	97.69 (2481)
WME092*S	E3012 / C3012	173.95 (4418)	188.08 (4777)	74.53 (1893)	102.65 (2607)
WME092*S	E3612 / C3012	175.89 (4467)	194.39 (4937)	82.88 (2105)	
WME106*S	E3612 / C3012			82.97 (2107)	
WME106*S	E3612 / C3612	174.64 (4435)	194.64 (4943)	85.13 (2162)	108.74 (2762)
WME092*D	E4216 / C3616	226.06 (5742)	251.21 (6380)	95.87 (2435)	111.24 (2825)
WME092*D	E4216 / C4216			98.03 (2490)	114.82 (2916)
WME099*D	E4216 / C4216				
WME106*D	E4216 / C4216				
WME106*D	E4816 / C4216	231.44 (5878)	256.94 (6526)	104.3 (2649)	117.41 (2982)

NOTE: 1. Unit configuration may be different than illustrated. Refer to certified drawings for specific configuration/dimensions.

NOTE: 2. Unit length represents 2 pass, 150 psi water box configuration with grooved connections.

NOTE: 3. Unit height represents largest configuration possible but does not include height of removable eye bolt.

Retrofit Knockdown

Magnitude WME chillers are relatively easy to disassemble due to the small compressor size, simplified refrigerant piping, and the absence of a lubrication system with its attendant components and piping. Various knockdown arrangements are available as options and are ideal for retrofit applications with tight installation clearances.

Bolt-Together Construction - Type A

Chillers are built and shipped completely assembled with bolt-together construction on major components for field disassembly and reassembly on the job site.

Figure 7: Bolt-Together Construction Option - Representative Schematic

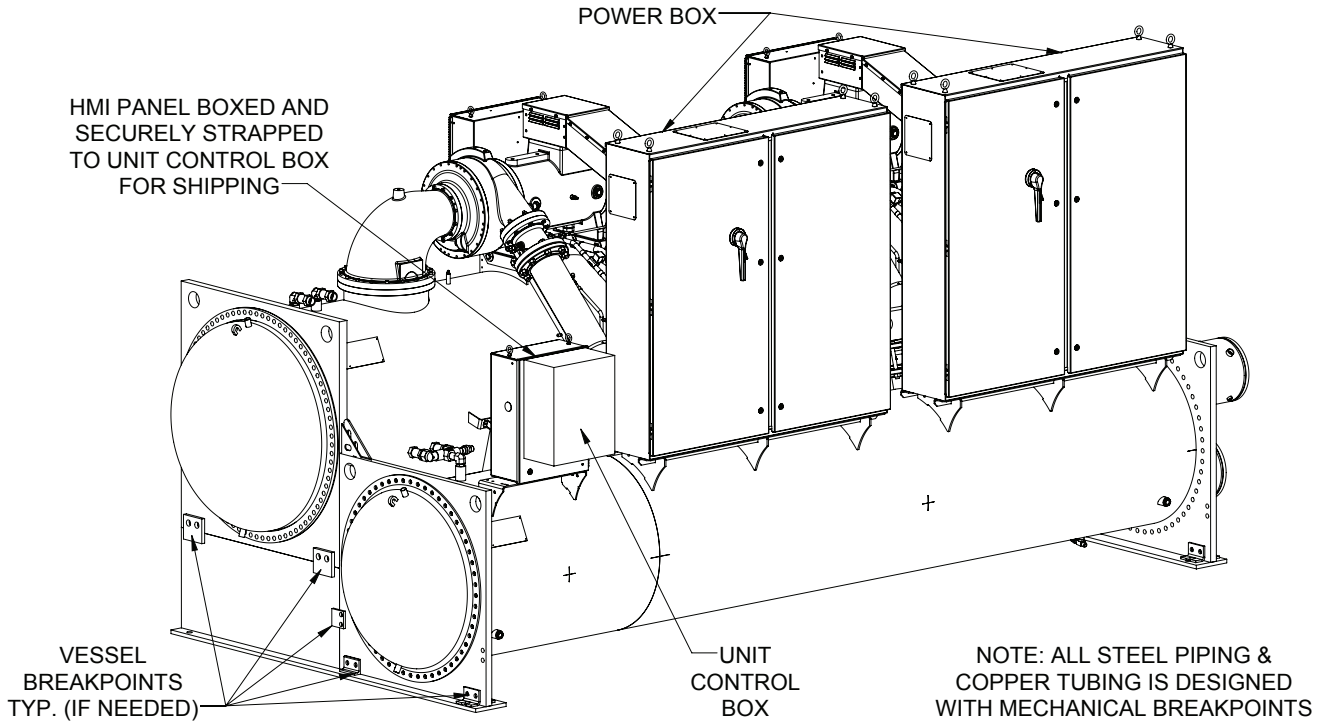

Scope:

- Site disassembly and reassembly must be supervised or completed by Daikin Applied service personnel.
- Unit is fully tested at the factory prior to shipment.
- The chiller is shipped completely assembled with the full refrigerant charge, which must be recovered before breaking any refrigerant connection.
- The refrigerant charge must be removed from the unit if the vessels are to be separated. Exert the proper precautions before attempting any disassembly, assume the condenser isolation valves may have leaked and that any component of the chiller may be pressurized with refrigerant.
- Suction and discharge lines have bolt-on flanges.
- Motor cooling line is brazed at mechanical connections.

- Blockoff plates are required to cover any refrigerant connection left open for extended periods of time. Contact Daikin Applied service to obtain these parts.
- Check that no power is being applied to the unit. Before disconnecting any wire, it is prudent to label its function and connection point to facilitate reconnection.
- Unit ships with vessel and/or head insulation, if ordered.
- Unit ships with replacement refrigerant gaskets and O-rings, stick-on wire ties, and touch-up paint. Some insulation repair and touch-up painting may be required.

 CAUTION
Standard torque specs must be followed when re-installing bolts. Contact Daikin Applied service for this information.

Partial Disassembly Construction - Type B

Compressor(s), power box(es), and control box are removed at the factory and shipped on separate skids; combined vessel stack is shipped together as a sub-assembly.

Figure 8: Partial Disassembly Construction Option - Representative Schematic

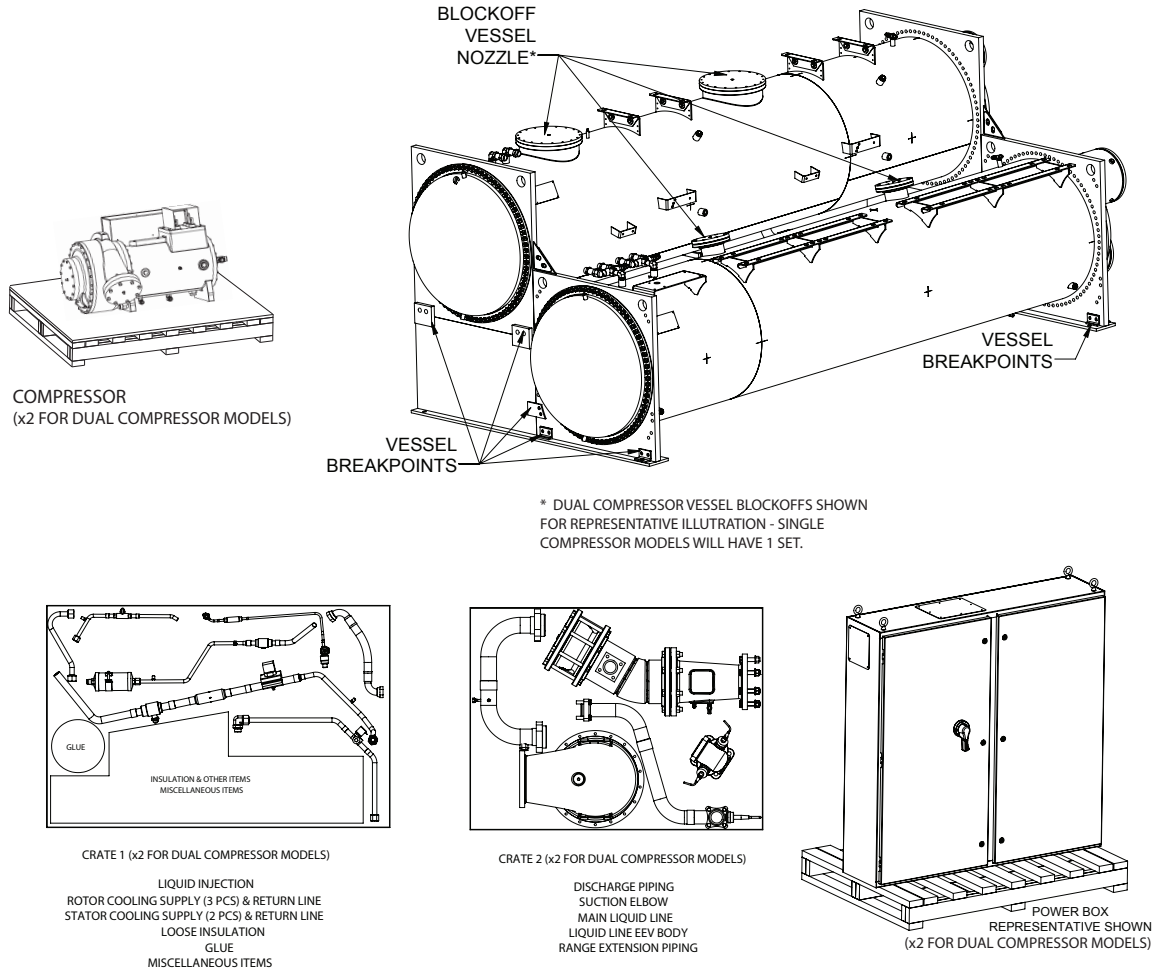

Scope:

- Site reassembly must be supervised or completed by Daikin Applied service personnel. Cost for unit reassembly and supervision by Daikin Applied service is not included in the purchase price of the equipment. Contact Daikin Applied service for pricing.
- Unit is fully tested at the factory prior to disassembly and shipment.
- All associated piping and wiring remain attached, if possible. Suction and discharge lines have bolt-on flanges and, if possible, remain attached. If the stack size or weight dictates further disassembly, the vessels can be separated by disconnecting any interconnecting wiring and tubing and then unbolting them.
- Refrigerant will not be shipped with the chiller and must be procured by others. Compressor(s) and vessels receive an inert gas holding charge that must be released prior to

attempting to open any connection.

- All free piping ends are capped. Blockoffs will cover all compressor and vessel openings.
- Unit ships with vessel and/or head insulation, if ordered.
- Unit ships with replacement refrigerant gaskets and O-rings, stick-on wire ties, and touch-up paint.

CAUTION

Standard torque specs must be followed when re-installing bolts. Contact Daikin Applied service for this information.

WARNING

Remove compressor, piping or vessel holding charge through the Schrader valve in the blockoff plates before attempting to loosen any fittings on them. Failure to do so can cause severe bodily injury.

Unit Knockdown Dimensions

NOTICE

Drawings, dimensional values, and other information may change depending on options or configurations selected. Refer to the as-built submittal drawings provided by a Daikin Applied sales representative for configuration-specific details.

Figure 9: Unit Dimensional Diagram for Typical WME Knockdown - Single Compressor Models

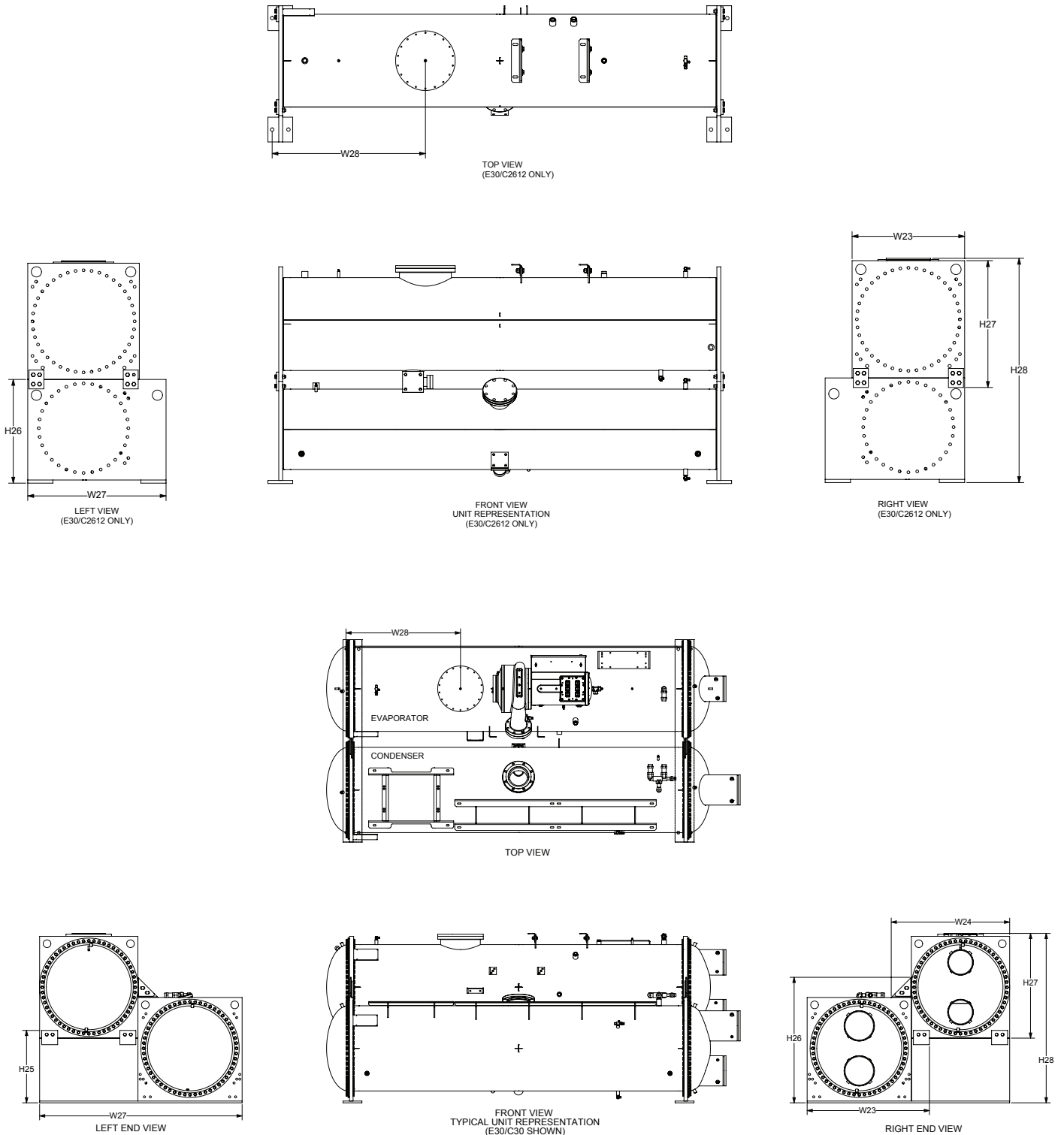
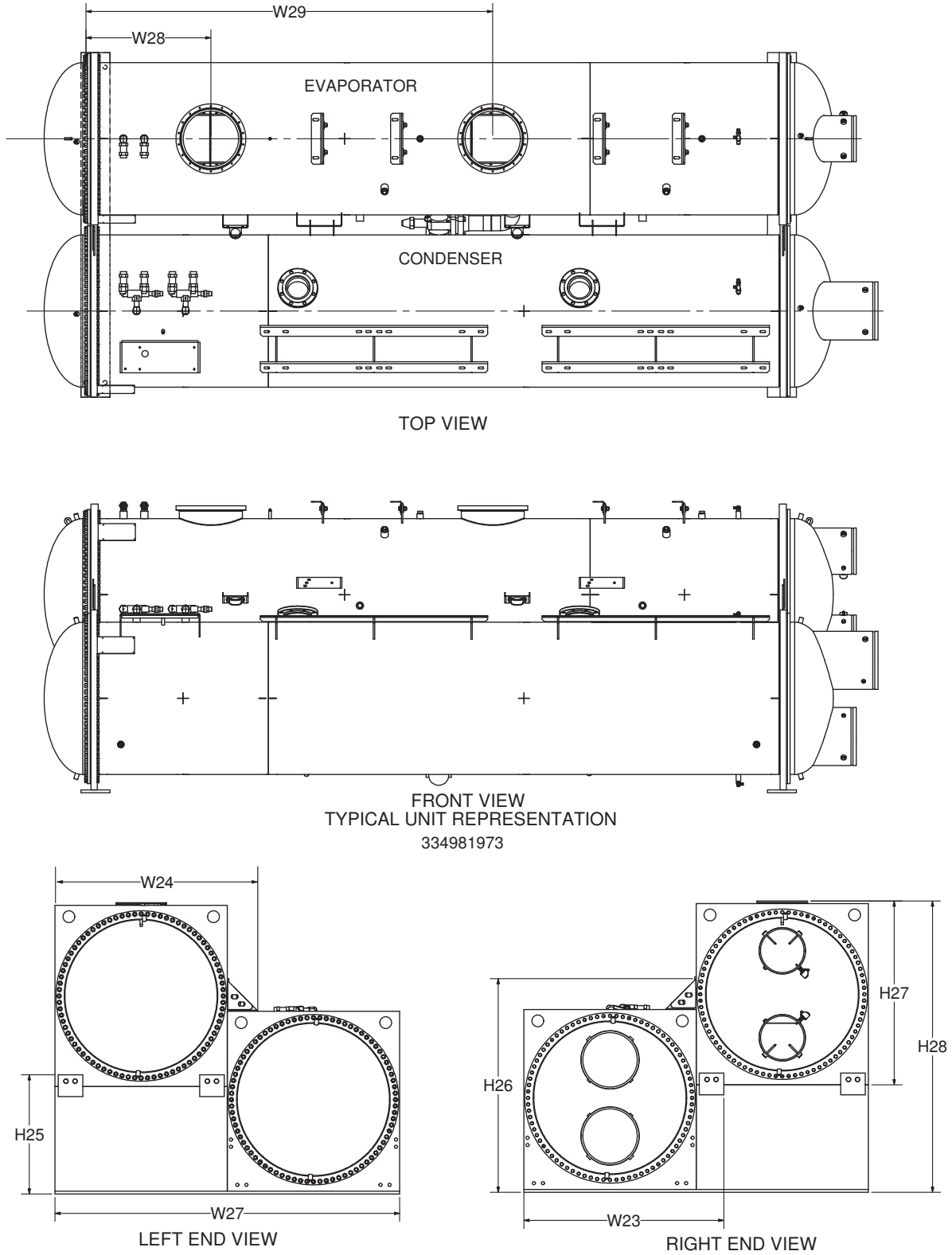

Figure 10: Unit Dimensional Diagram for Typical WME Knockdown - Dual Compressor Models



NOTE: See page 10 for overall unit length, width, and height dimensions for WME models.

Table 3: WME Knockdown Dimensions

Label	Dimensions - inches (mm)									
	WME092*S			WME106*S		WME092*D		WME099*D	WME106*D	
	E3012/ C2612	E3012/ C3012	E3612/ C3012	E3612/ C3012	E3612/ C3612	E4216/ C3616	E4216/ C4216	E4216/ C4216	E4216/ C4216	E4816/ C4216
W23	35.5 (901)	40.6 (1032)	43.1 (1095)	48.1 (1223)	52.6 (1336)	51.0 (1295)	55.1 (1400)	55.1 (1400)	55.1 (1400)	55.1 (1400)
W24	---	44.0 (1117)	50.0 (1270)	50.0 (1270)	50.0 (1270)	56.0 (1422)	56.0 (1422)	56.0 (1422)	56.0 (1422)	62.0 (1575)
W27	44.0 (1117)	71.0 (1803)	77.0 (1956)	82.0 (2084)	85.5 (2171)	91.5 (2324)	95.0 (2413)	95.0 (2413)	95.0 (2413)	101.0 (2565)
W28	50.8 (1291)	48.7 (1237)	48.7 (1238)	48.2 (1224)	48.2 (1224)	35.8 (909)	35.8 (909)	35.8 (909)	35.2 (896)	35.2 (896)
W29	---	---	---	---	---	113.5 (2883)	113.5 (2883)	113.5 (2883)	112. (2869)	112.9 (2869)
H25	---	19.9 (506)	18.9 (480)	21.1 (536)	30.5 (776)	24.1 (613)	32.8 (834)	32.8 (834)	32.8 (834)	33.0 (840)
H26	33.0 (838)	47.0 (1194)	47.0 (1194)	47.0 (1194)	53.0 (1346)	51.4 (1306)	58.8 (1495)	58.8 (1495)	58.8 (1495)	59.1 (1501)
H27	40.0 (1016)	37.7 (958)	44.2 (1123)	44.2 (1123)	44.2 (1123)	50.0 (1270)	50.0 (1270)	50.0 (1270)	50.0 (1270)	54.5 (1384)
H28	70.2 (1784)	54.7 (1389)	58.6 (1489)	62.1 (1577)	71.5 (1817)	71.1 (1807)	79.5 (2021)	79.5 (2021)	79.5 (2021)	84.3 (2141)

Table 4: Label Descriptions for Unit Dimensional Diagrams

Label	Description
W23	Width (Condenser Tubesheet with Mounting Brackets)
W24	Width (Evaporator Tubesheet with Mounting Brackets)
W27	Width (Mounting Foot with Mounting Brackets)
W28	Width (Center of Outside Foot Mounting Hole to Center of Suction #1)
W29	Width (Center of Outside Foot Mounting Hole to Center of Suction #2)
H25	Height (Mounting Foot with Mounting Brackets)
H26	Height (Condenser Tubesheet with Mounting Brackets)
H27	Height (Evaporator Tubesheet with Mounting Brackets)
H28	Height (Unit Height from Bottom of Foot to Top of Suction)

Table 5: Component Weights

Component	Dry Weight*	
	lbs.	kg
E3012 Evaporator	4669	2118
E3612 Evaporator	6769	3070
E4216 Evaporator	11591	5258
E4816 Evaporator	14888	5790
C2612 Condenser	5010	2272
C3012 Condenser	7210	3270
C3612 Condenser	9801	4446
C3616 Condenser	13118	5950
C4216 Condenser	17845	8094
Power Panel	3100	1406

NOTE: * Component weights based on largest unit with standard tube configuration.

Figure 11: Representation - WME Compressor Dimensions

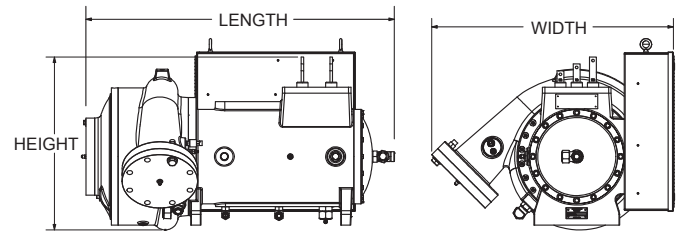

Compressor Dimensions

The compressor dimensions vary by model. All dimensions and weights per compressor are listed in Table 6.

Table 6: Dimensions for WME Compressors

Model	Length in. (mm)	Width in. (mm)	Height in. (mm)	Weight lb. (kg)
WME092	44.85 (1139)	32.91 (835)	24.50 (622)	893 (405)
WME106	44.95 (1141)	35.21 (894)	25.19 (639)	1050 (476)

Table 7: Compressor Usage

Unit Model Numbers	Compressor Models Used
WME092CS	1 – 092X
WME092DS	1 – 092Y
WME106CS	1 – 106X
WME106DS	1 – 106Y
WME092CD	2 – 092X
WME092DD	2 – 092Y
WME099CD	1 – 092X, 1 – 106X
WME099DD	1 – 092Y, 1 – 106Y
WME106CD	2 – 106X
WME106DD	2 – 106Y

Compressor Rigging Requirements

To properly rig the compressor, install swivel lifting eye-bolts in the two holes on the top of the compressor (see Figure 14, flag #9). Use a spreader bar between the two chain hoists, as shown in Figure 12, to safely lift the compressor. Note compressor weights and dimensions in Table 5 and Table 6, as well as unit rigging instructions in Figure 5 on page 9.

Figure 12: WME Compressor Rigging Setup

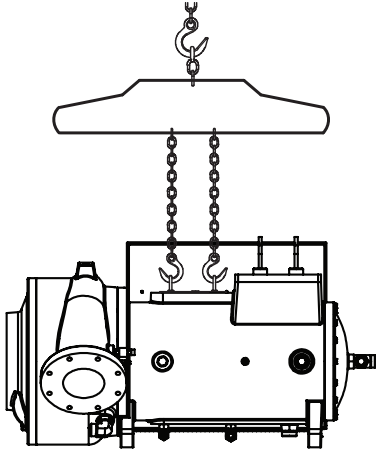

NOTICE

The spreader bar in Figure 12 is a representation only and may not reflect the appearance of the actual spreader bar needed.

Compressor Removal and Re-Attachment Instructions

CAUTION

Prior to removing the compressor, follow any and all local safety guidelines and procedures for removing refrigerants. Always recover the refrigerant charge completely from the chiller to an approved refrigerant vessel.

Compressor Removal Preparation

1. Close shut-off (king valve at main liquid line of condenser).
2. Close all other related shut-off valves.
3. Ensure that the charge has been removed from the unit.
4. Loosen and remove bolts at hot gas bypass flange.
5. Loosen and remove bolts on the top side of the compressor discharge nozzle (see Figure 13, flag #5).
6. Loosen and remove bolts at flange on condenser and remove discharge piping.

WARNING

Improper rigging, lifting, or moving of a unit can result in property damage, severe personal injury or death. Follow rigging and moving instructions carefully.

Figure 13: Compressor Removal Preparation

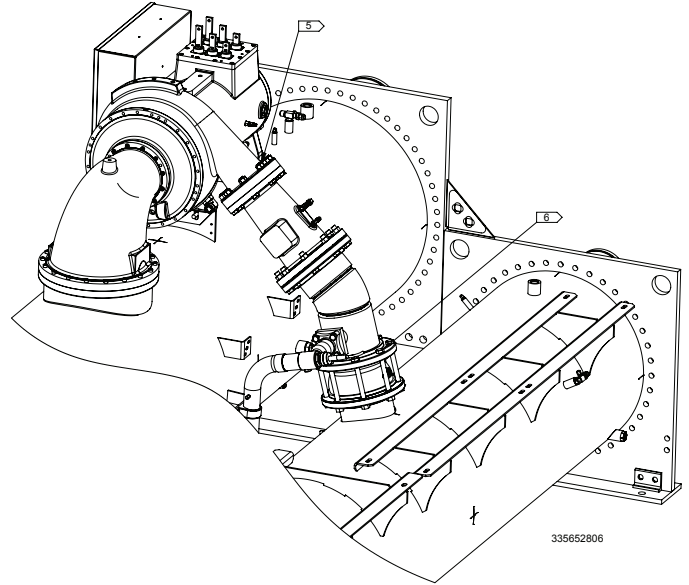

Compressor Removal

1. Loosen and remove bolts/screws on either side of the cast suction elbow (see Figure 14, flag #1).

Figure 14: Compressor Removal/Re-Attachment

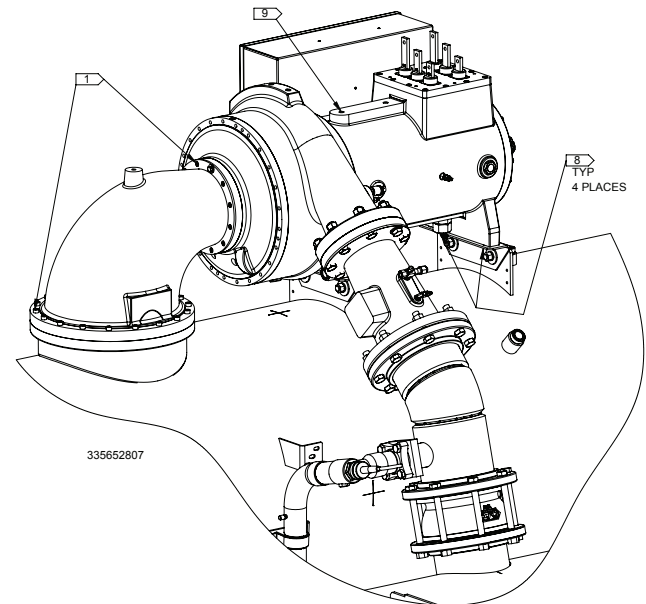

2. Remove rotor cooling return line on the underside of the compressor motor housing along with both rotor cooling supply lines.
3. Remove (2) DIN connectors from the solenoid coils along refrigerant piping.
4. Remove rotor stepping valve control wire. The wire ties will have to be cut away during this process.

5. Remove the following wires coming from the VFD:
 - 350V DC power supply (gray cable)
 - power leads on the top of the motor housing
6. Remove the Ethernet cable coming from unit control box.
7. Remove the wireway box assembly from the compressor to the back of the starter.
8. Loosen the (4) bolts from the compressor's bottom mounting feet (see [Figure 14](#), flag #8).

NOTICE

Do not loosen or remove bolts securing the compressor brackets as height is pre-set from the factory.

9. Use front tapped lifting hole on the compressor motor housing (see [Figure 14](#), flag #9) to rig compressor for removal as shown in [Figure 12](#). Note weights and unit rigging instructions.

Compressor Re-Attachment

1. Set the suction elbow back on top of the evaporator and install the bolts/screws loosely at the evaporator flange. Use new O-rings provided.
2. Set the discharge piping back on top of the condenser and install the bolts loosely at the condenser flange. Use the new gasket supplied with the unit.
3. Set compressor on mounting brackets and install the (4) mounting bolts loosely. Reconnect the discharge nozzle with new O-rings provided and also at the suction elbow.

NOTICE

For steps 4-6, all bolts need to be installed loosely first before final torque is applied.

4. Install (12) bolts/screws at suction elbow to compressor and torque to 25 ft-lbs max; do not over-tighten.
5. Install (18) bolts at evaporator flange to the suction line and torque to 62 ft-lbs max; do not over-tighten.
6. Install and torque the (8) bolts at the discharge nozzle to 205 ft-lbs, then torque the (8) bolts at the condenser flange to the same.
7. Torque the (4) compressor mounting bolts to 25 ft-lbs max; do not over-tighten.
8. Re-install the (4) flange bolts at the hot gas bypass line.
9. Re-install the wireway between compressor and VFD.
10. Re-attach all associated power wiring & Ethernet cable.
11. Re-attach rotor cooling return line on the underside of the compressor motor housing along with both liquid injection lines.
12. Pull vacuum at evaporator and compressor to 300 microns and perform a standing hold to verify no moisture or leaks - do not allow rise of 300 microns within 1 hour.
13. After verifying that pumps are running and water flow has been established on both evaporator and condenser, add vapor refrigerant to bring the saturated temperature above freezing. Open all valves.

14. Perform refrigerant leak check to ensure all connections and fittings are securely fastened.

Water Piping

All evaporators and condensers have OGS-type grooved water connections (adhering to Standard AWWA C606) or optional flange connections. The installing contractor must provide matching mechanical connections. Be sure that water inlet and outlet connections match certified drawings and nozzle markings. PVC/CPVC piping should not be used.

WARNING

Polyolester Oil, commonly known as POE oil is a synthetic oil used in many refrigeration systems, and may be present in this Daikin Applied product. POE oil, if ever in contact with PVC/CPVC, will coat the inside wall of PVC/CPVC pipe causing environmental stress fractures. Although there is no PVC/CPVC piping in this product, please keep this in mind when selecting piping materials for your application, as system failure and property damage could result.

CAUTION

If welding is to be performed on the mechanical or flange connections:

1. Remove the solid-state temperature sensor, thermostat bulbs, and nozzle mounted flow switches from the wells to prevent damage to those components.
2. Properly ground the unit or severe damage to the MicroTech unit controller can occur.

ASME certification will be revoked if welding is performed on a vessel shell or tube sheet.

The water heads can be interchanged (end for end) so that the water connections can be made at either end of the unit. If this is done, use new head gaskets and relocate the control sensors.

Field installed water piping to the chiller must include:

- Air vents at the high points.
- A cleanable water strainer upstream of the evaporator and condenser inlet connections.
- A flow proving device for both the evaporator and condenser to prevent freeze up. Flow switches, thermal dispersion switches, or Delta P switches can be used. Note that flow switches are factory installed. Additional flow switches can be used only if they are connected in series with the ones already provided. Connect additional flow switches in series between original flow switch inputs. Calibration of thermal dispersion flow switches is discussed on [page 50](#).
- Sufficient shutoff valves to allow vessel isolation. The chiller must be capable of draining the water from the evaporator or condenser without draining the complete system.
- Piping must be supported to eliminate weight and strain on the fittings and connections.
- Chilled water piping must be adequately insulated.

Recommended field installed chiller water piping includes:

- Thermometers at the inlet and outlet connections of both vessels.
- Water pressure gauge connection taps and gauges at the inlet and outlet connections of both vessels for measuring water pressure drop.

NOTICE

This product, in its standard configuration, is equipped with a shell and tube evaporator with carbon steel shell and copper tubes. The water or other fluid used in contact with the wetted surfaces of the heat exchangers must be clean and non-corrosive to the standard materials of construction. Daikin Applied makes no warranty as to the compatibility of fluids and materials. Non-compatible fluids may void the equipment warranty. If the compatibility of the fluid with the standard materials of construction is in question, a professional corrosion consultant should administer the proper testing and evaluate compatibility.

Vessel Drains at Startup

The unit is drained of water at the factory. Units are shipped with the drain plug in the top water box drain hole and no plug in the bottom drain hole. Drain plugs for each vessel head are shipped separately in the control box. Be sure to install the bottom drain plugs prior to filling the vessel with fluid.

Figure 15: Drain Plug Installation

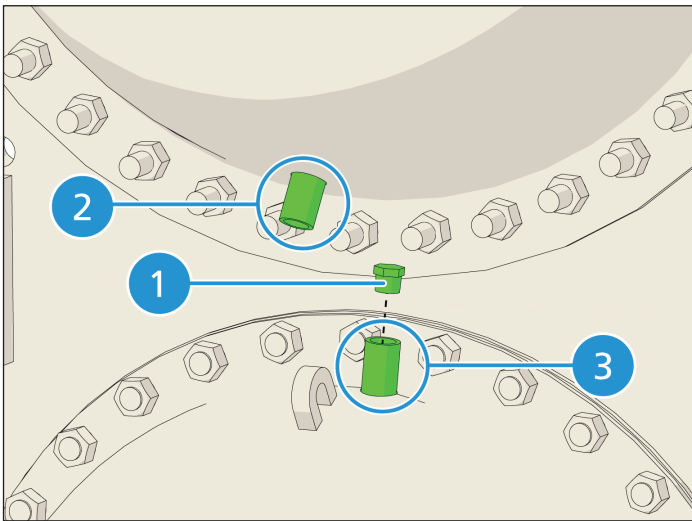

No.	Description
1	Plug
2	Drain Hole (Under Insulation)
3	Vent Hole (Air Purge)

Water Quality Guidelines

The water quality provided by the owner/occupant/operator/user to a chiller system should minimize corrosion, scale buildup, erosion, and biological growth for optimum efficiency of HVAC equipment without creating a hazard to operating personnel or the environment. Strainers must be used to protect the chiller systems from water-borne debris. Daikin Applied will not be responsible for any water-borne debris damage or water side damage to the chiller heat exchangers due to improperly treated water.

Water systems should be cleaned and flushed prior to chiller installation. Water testing and treatment should be verified during initial chiller installation/commissioning and maintained on a continuous basis by water treatment professionals (see Limited Product Warranty).

WARNING

The improper use of detergents, chemicals, and additives in the chiller system water may adversely affect chiller performance and potentially lead to repair costs not covered by warranty. Any decision to use these products is at the discretion of the owner/occupant/operator/user and as such they assume full liability/responsibility for any damage that may occur due to their use.

Field Insulation

If the optional factory installation of thermal insulation is not ordered, insulation should be field installed to reduce heat loss and prevent condensation from forming. Insulation should cover:

- The evaporator barrel, tube sheet, and waterboxes.
- The suction line from the top of the evaporator to the compressor inlet flange.
- The compressor support brackets welded to the evaporator.
- The liquid line from the expansion valve to the evaporator inlet, including the expansion valve.
- The part load balance valve to the evaporator.

Approximate total square footage of insulation surface required for individual packaged chillers is tabulated by evaporator code and can be found in [Table 8](#).

Table 8: Insulation Area Required for WME Models

Evaporator Code	Insulation Area sq. ft. (m ²)
E3012	115 (10.6)
E3612	129 (11.9)
E4216	263 (24.4)
E4816	302 (28.1)

Relief Valves

As a safety precaution and to meet code requirements, each chiller is equipped with pressure relief valves located on the condenser and evaporator for the purpose of relieving excessive refrigerant pressure (caused by equipment malfunction, fire, etc.) to the atmosphere.

Table 9: WME, C-vintage Relief Valve Data

	Evaporator	Condenser
Location	Top	Top
Pressure Setting (psi)	200	225
Pressure Setting (psi) for R-515B Only	165	165
Discharge Capacity	78.8 lb/min. air	88.1 lb/min. air
Discharge Capacity for R-515B Only	61.3 lb/min. air	61.3 lb/min. air
Qty	1 - 30 & 36 inch vessels 2 - 42 & 48 inch vessels	2 - 26, 30, 36 inch vessels 4 - 42 inch vessels
Connection	1.0-inch female NPT	

Most codes require that relief valves be vented to the outside of a building. Relief piping connections to the relief valves must have flexible connectors.

CAUTION

Units are shipped with refrigerant valves closed to isolate the refrigerant in the unit condenser. Valves must remain closed until startup by the factory service technician.

Remove plastic shipping plugs (if installed) from the inside of the valves prior to making pipe connections. Whenever vent piping is installed, the lines must be in accordance with local code requirements. Where local codes do not apply, the latest issue of ANSI/ASHRAE Standard 15 code recommendations must be followed.

Condenser Relief Valves

In order to ensure proper installation, it is important to know how the three-way relief valve functions. One valve remains active at all times and the second valve acts as a standby. When the stem of the three-way valve is pushed into the valve completely, the valve is in “Front Seated Position” and all refrigerant will flow through the back outlet port, as shown in Figure 17. When the stem of the three-way valve is pulled back completely, the valve is in “Back Seated Position” and all refrigerant will flow through the front outlet port, as shown in Figure 18.

Figure 16: Three-Way Relief Valve

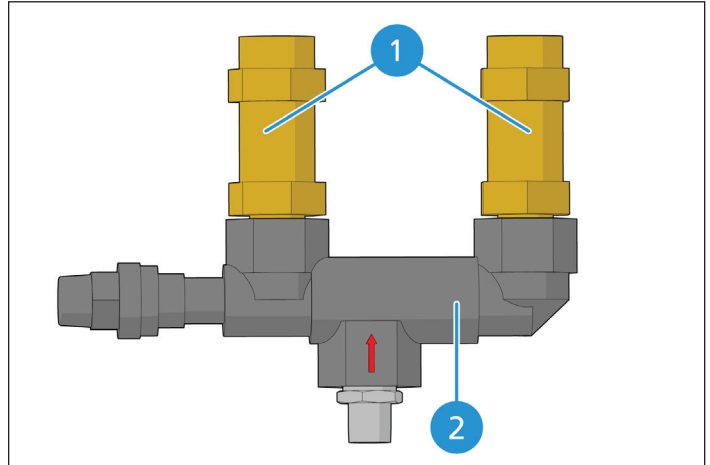

No.	Description
1	Relief Valves
2	Three-Way Valve

Figure 17: Front Seated Position

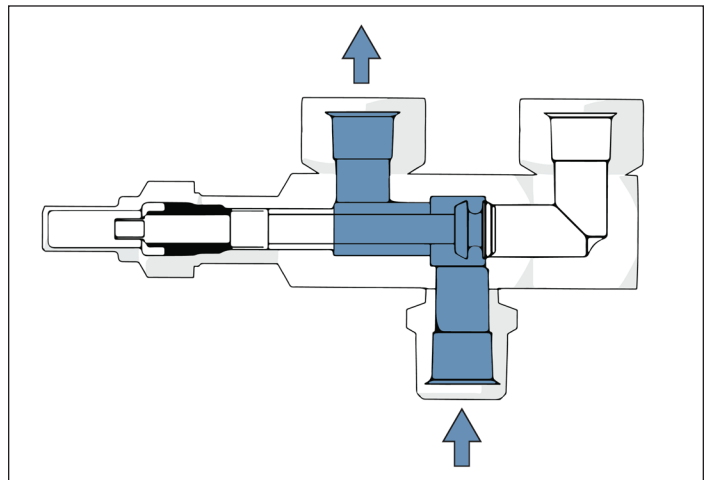
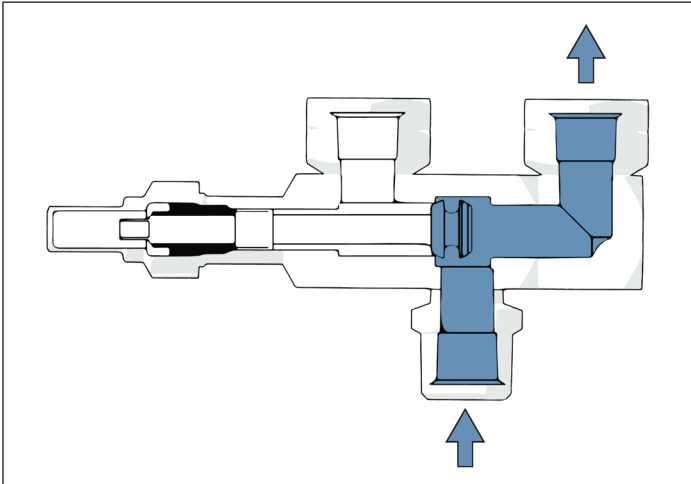

Figure 18: Three Way Valve, Back Seated Position



When the valve stem is not pushed forward or pulled back completely, the valve is in “Mid Position,” as shown in Figure 19.

CAUTION

Do not operate the system with the three-way valve stem in the Mid Position.

Figure 19: Three-Way Valve, Mid Position

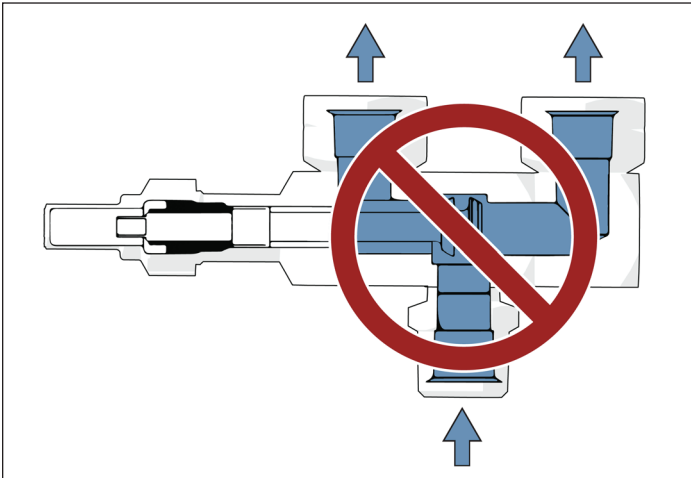

Electrical

Field Power Wiring

The standard power wiring connection to Magnitude chillers is multi-point for dual compressor WME models. Power conduit entry will be at the top of the unit power panel; see Figure 20 for general reference as power entry cover plate location will vary by unit configuration. Copper wiring must be used for power wiring. Refer to the unit nameplate and the Daikin Tools selection report for the correct electrical ratings.

⚠ DANGER

Qualified and licensed electricians must perform wiring. An electrical shock hazard exists that can cause severe injury or death.

Figure 20: Unit Power Connection Point

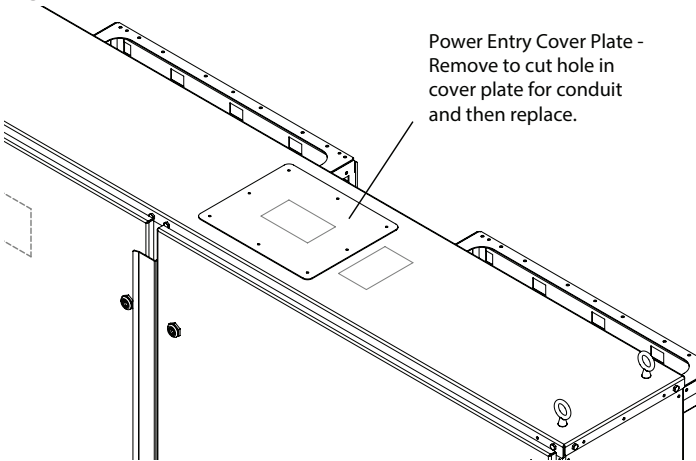

Factory-mounted and wired line reactors are standard. The field control wiring required varies depending on unit model. See the WME-C Field Wiring Schematic for wiring information. These wiring diagrams are also provided with the chiller.

NOTICE

Wiring, fuse, and wire size must be in accordance with the National Electrical Code® (NEC). The voltage to these units must be within ±10% of nameplate voltage (415V units must have voltage within -13% and +6% of nameplate voltage) and the voltage unbalance between phases must not exceed 2%. Since a 2% voltage unbalance will cause a current unbalance of 6 to 10 times the voltage unbalance per the current version of the NEMA MG-1 Standard, it is most important that the unbalance between phases be kept at a minimum.

⚠ CAUTION

Do not use power factor correction capacitors with WME chillers. Doing so can cause harmful electrical resonance in the system. Correction capacitors are not necessary since VFDs inherently maintain high power factors.

See page 45 for additional information on Generator Sizing and Transferring Power.

Chiller Control Power

In all cases of power operation except when with RapidRestore®, the chiller control power must remain as factory-wired from a unit-mounted power supply.

BAS Connection

If BAS module is needed for BACnet® or Modbus, the UE1 module will be replaced with the BUE1 module shown in Figure 21 for wiring. When Lon protocol is used the UE1 module remains and a Lon card is connected to the Unit controller in the BMS CARD port.

Figure 21: BAS Module Wiring Schematic

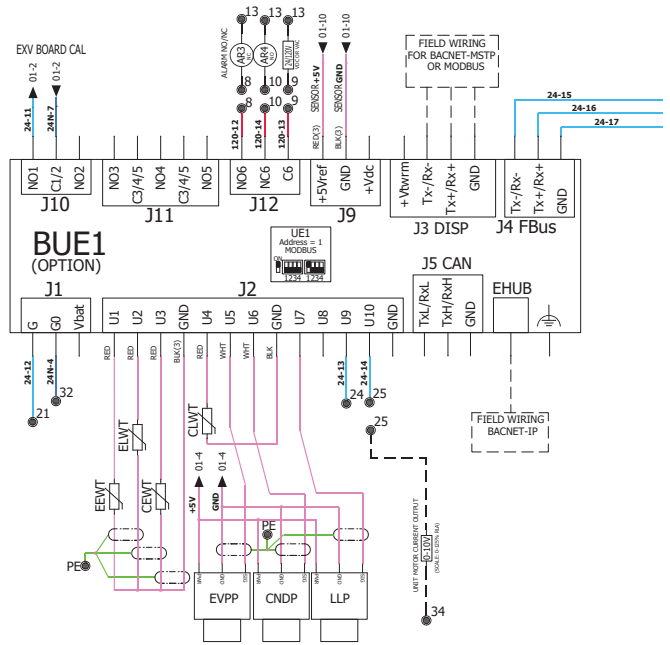

RapidRestore and RideThrough

WME chillers have the capability for chillers to restart and reach full load operation quickly in the event of a power loss.

RapidRestore® – Quickly restores cooling capacity when power is restored after a power failure.

- **Compressor Re-Start** – Amount of time required for the chiller to re-start.
- **Fast Loading** – Amount of time required for the chiller to reach a certain load condition.

RideThrough® – The ability to maintain operation during a momentary power loss event. When RideThrough is enabled and a power loss occurs, the compressor motor maintains rotation and the VFD catches and re-synchronizes with the spinning rotor. This permits the chiller to return to its pre-power loss capacity within seconds of power being restored.

Table 10: RapidRestore and RideThrough Times

Standard Compressor Re-Start	RapidRestore Compressor Re-Start	Fast Loading to 80% Load	RideThrough
60 sec	20 sec after power failure*	75 sec**	17 sec***

* Requires customer supplied Uninterruptible Power Supply (UPS) to the WME control panel.
 ** After compressor re-start time
 *** Time is based on unit operating at AHRI conditions.

Figure 22: RapidRestore Wiring Diagram

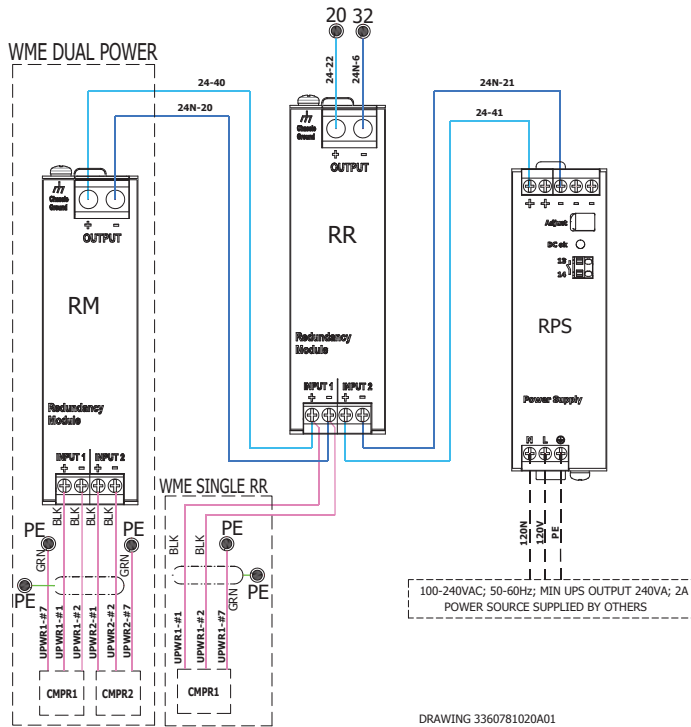

Power Panel Short Circuit Current Ratings

Available short circuit current ratings (SCCR) are shown in Table 11.

Table 11: Short Circuit Current Ratings

Motor Code	Voltage	Standard Panel SCCR	Optional High SCCR	Optional Ultra High SCCR
M6, M7, 66 and 77	380V - 480V	35 kA* / 50 kA	65 kA	100 kA
	575V	25 kA	35 kA / 50 kA	N/A
68 and 79	380V - 480V	N/A	65 kA	100 kA
	575V	25 kA	35 kA / 50 kA	N/A
M8, M9, 88 and 99	380V - 480V	50 kA	65 kA	100 kA
	575V	25 kA	35 kA	65 kA

* 600 amp circuit breaker frame size has a 35 kA SCCR rating. 800 amp circuit breaker frame size has a 50 kA SCCR rating.

Figure 23: WME Field Wiring Schematic

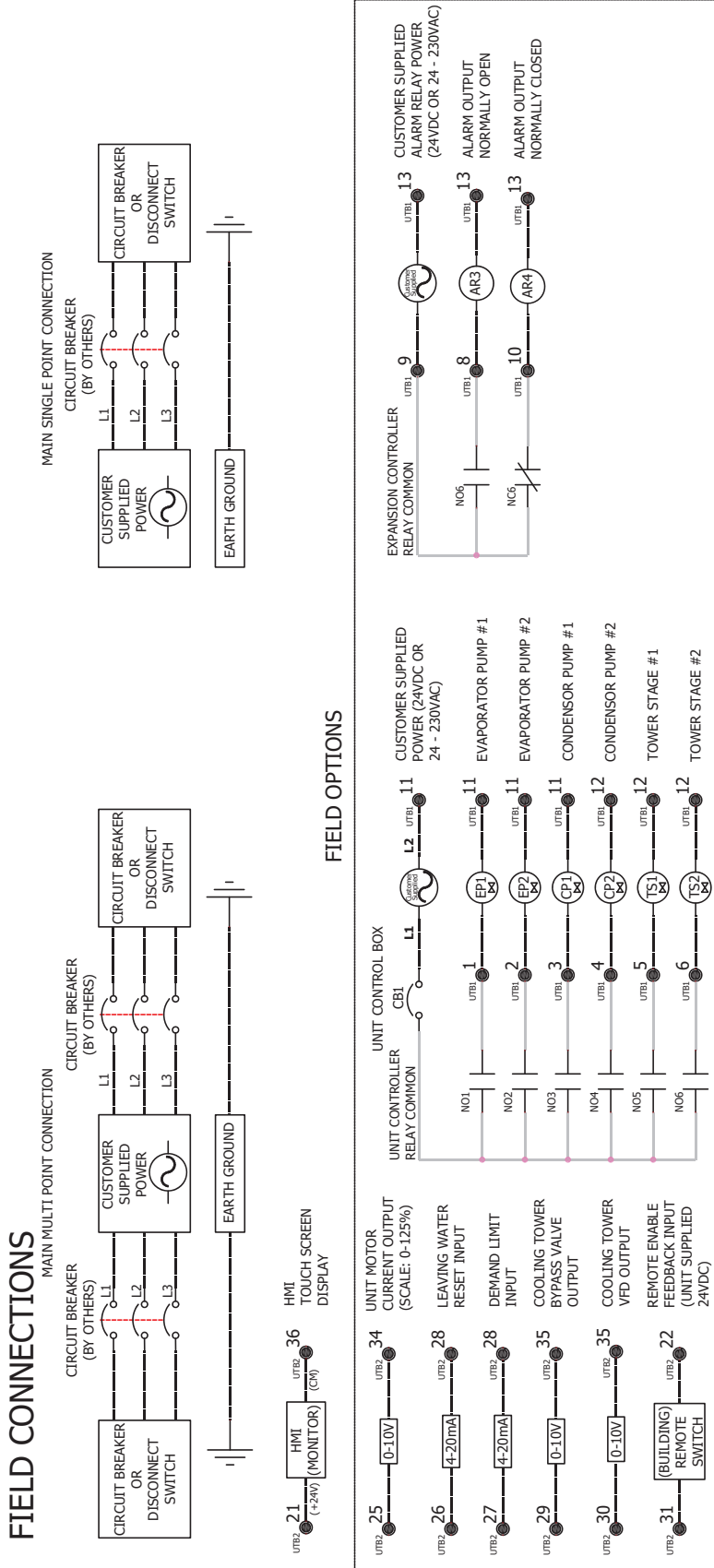
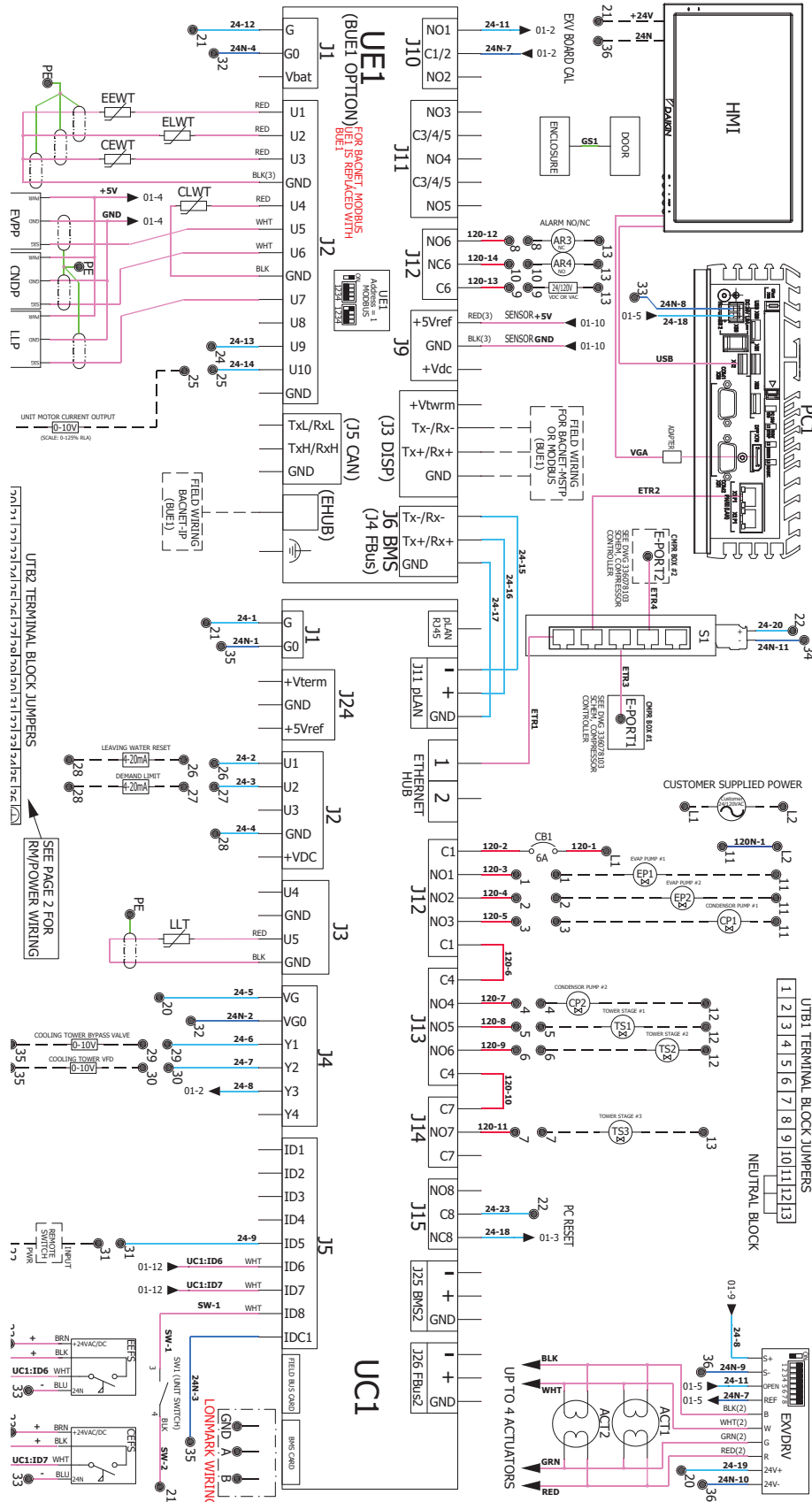

Figure 24: WME Unit Wiring Schematic



Operation

Operator Responsibilities

It is important that the operator becomes familiar with the equipment and the system before attempting operation. During the initial startup of the chiller, the Daikin Applied technician will be available to answer any questions and instruct the proper operating procedures. It is recommended that the operator maintain an operating log for each individual chiller unit. In addition, a separate maintenance log should be kept of the periodic maintenance and servicing activities.

Operator Schools

Training courses for Magnitude Centrifugal Maintenance and Operation are available online. The school curriculum includes instruction on basic refrigeration, MicroTech controllers and troubleshooting, enhancing chiller efficiency and reliability, system components, and other related subjects. For more information, visit us at www.DaikinApplied.com and click on Training or call the Training Department. Refer to the back cover of this manual for contact information.

For additional resources, Visit www.daikinapplied.com/training/our-training.

Sequence of Unit Operation

A general chiller sequence of operation is outlined below for Magnitude Model WME chillers. A separate sequence is provided for single and dual compressor units. Certain conditions and chiller alarms may alter the sequence, but the chiller's objective is to achieve the target temperature of the leaving water.

Placing two chillers in series evaporator operation or series-counterflow configuration is possible and requires connecting an Ethernet cable between the unit control panels and reassigning a temperature sensor. Communication directly between the chillers allows better control of leaving water temperature while balancing the load. Contact a Daikin Applied representative for specific details.

Single Compressor Units

The following sequence of operation applies to Magnitude® Model WME chillers with a single compressor.

1. Chiller enabled

With the chiller enabled via its onboard interlocks and selected external control source, it will start the evaporator pump and check for flow and chiller load.

2. Water flow and load proven

Once evaporator flow has been confirmed and the chiller load proven, the sequence for starting the compressor will begin.

3. Compressor shaft levitation

The magnetic bearings are activated and correct shaft

position is verified.

4. Condenser pump start

The condenser pump is commanded to start and water flow is confirmed. Electronic Expansion Valve (EXV) must be open

5. Compressor start

The compressor is started and comes up to the calculated Start RPM and Inlet Guide Vane (IGV). From this point the vanes are opened and then speed is increased to match the cooling load.

6. Compressor loading

As building load increases, the compressor will load up maximizing the IGV position and impeller speed. Maximum capacity at a given operating condition can be found when the compressor reaches its Maximum RPM, maximum allowed % RLA or power limitation.

7. Compressor unloading

As load decreases, the compressor will unload to sustain the water temperature setpoint by reducing speed until the minimum speed limit has been reached. If further unloading is required, the IGV assemblies will close as required to satisfy the load. Further capacity reduction is accomplished by opening the Part Load Balance Valve (PLBV).

8. Chiller shutdown

The compressor will adjust capacity to manage the chiller load and will shut off when the load reduces below the compressor's minimum capacity and the leaving water temperature goes below setpoint and reaches the stop delta temperature. Anytime the chiller is disabled, it will perform an orderly unload and shutdown of the compressor.

Dual Compressor Units

The following sequence of operation applies to Magnitude® Model WME chillers with dual compressors.

1. Chiller enabled

With the chiller enabled via its onboard interlocks and selected external control source, it will start the evaporator pump and check for flow and chiller load.

2. Water flow and load proven

Once evaporator flow has been confirmed and the chiller load proven, the sequence for starting the Lead compressor will begin. Auto lead-lag logic will determine which compressor to start first based on number of starts. For 099 models, the smaller compressor will start first.

3. Compressor shaft levitation

The magnetic bearings are activated and correct shaft position is verified.

4. Condenser pump start

The condenser pump is commanded to start and water flow is confirmed. EXV must be open.

5. Lead compressor start

The compressor is started and comes up to the calculated Start RPM and IGV. From this point the vanes are opened and then speed is increased to match the cooling load. When the Lead compressor reaches an operating point where it would be more efficient to operate two compressors, it signals the Lag compressor to initiate a start sequence and may adjust its capacity to assist the Lag compressor start. In many cases the Lag will start before the Lead reaches 100% of RLA.

6. Lag compressor start

Depending on the pressure ratio, the running compressor may unload before starting the lag compressor. Once started, the lag compressor will quickly ramp up to balance the chiller load between the two compressors. A Tandem start will occur on the lag request if the pressure ratio is high during a request for next compressor. During a tandem start the Lead compressor will perform a partial shut down and start again with the Lag compressor.

7. Dual compressor loading

As building load increases, the compressors will load up maximizing the Inlet Guide Vane (IGV) position and impeller speed. Maximum capacity at a given operating condition can be found when the compressors reach their Maximum RPM, maximum allowed % RLA or power limitation. While maintaining the desired evaporator leaving water temperature, the two compressors will balance load.

8. Dual compressor unloading

As load decreases, the compressors will unload to sustain the water temperature setpoint by reducing speed until the minimum speed limit has been reached. If further unloading is required, the IGV assemblies will close as required to satisfy the load. Further capacity reduction is accomplished by opening the PLBV.

9. Staging down to one compressor running

With the chiller running two compressors on condition and the building load reducing to the point that one compressor can carry the load more efficiently than two can, one compressor will be shut down based on compressor run hours. For 099 models, the smaller compressor will stop first.

10. Chiller shutdown

The remaining compressor will adjust capacity to manage the chiller load until the load increases to the point where another compressor is needed, or the load reduces below the minimum capacity of one compressor and the leaving water temperature goes below setpoint and reaches the stop delta temperature. Anytime the chiller is disabled, it will perform an orderly unload and shutdown both compressors.

Unit Enabling/Disabling and Overrides

There are multiple options that will override normal operation of the chiller and its compressors:

1. Manual Button - Located on the outside front of the control panel. Button needs to be engaged for unit to run. When disengaged, unit will perform rapid stop. For a controlled shutdown sequence, use the HMI Enable Button, BAS command, or Remote Enable signal. This button is the only method to override other "Control Sources".

NOTICE

This setting can also be changed using SiteLine.

2. Compressor 1 or 2 Enable Setting - Located in the Settings menu, Modes tab in the HMI.

The overrides listed above work in conjunction with the "Control Source" that is selected in the HMI via the Settings/Modes Screen, see [Figure 41](#) and [Table 15](#) on [page 34](#). The three options for "Control Source" are:

1. HMI Enable Button (Local) - This is the default mode. When this mode is set, a STOP button and an AUTO button will appear at the top of the HMI screens. If the "Control Source" is set to "HMI Enable Button" and a remote switch is being used, the position of the Remote Enable switch will be ignored. In that case, only the Manual Button need to be closed. Once the Manual Button is engaged, press the AUTO button on the HMI to enable the chiller in "User" mode. It will also ignore BAS Network commands.
To disable the chiller, press the STOP button on the HMI screen.
2. Remote Enable - This mode will ignore BAS enable and disable commands and requires a physical switch. To enable the chiller and its compressors, the Manual Button needs to be closed in the ON position. To disable the unit, this switch will initiate a normal controlled sequence and will stop each compressor that is running.
3. BAS Network - This mode allows BAS to enable or disable the chiller over a BAS network. To enable the chiller and its compressors, the Manual Button needs to be closed in the ON position. When a BAS Network command to disable is given, the chiller will shutdown the chiller in a normal controlled sequence and will stop each compressor that is running.

Variable Fluid Flow Rates

Both excessively high and low fluid flow rates should be avoided. Extremely high fluid flow rates and high tube velocities will result in high fluid pressure drops, high pumping power, and potential tube erosion or corrosion damage. Extremely low fluid flow rates and low velocities should also be avoided as they will result in poor heat transfer, high compressor power, sedimentation and tube fouling.

If it is decided to vary the evaporator or condenser water flow rate, the flow rate should not exceed the minimum or maximum limits. Additionally, the rate of change for the evaporator flow rate should not exceed 10% of the current value per minute.

Water Volume

All chilled water systems need adequate time to recognize a load change to avoid short cycling of the compressors or loss of control. The potential for short cycling usually exists when the building load falls below the minimum chiller plant capacity or on close-coupled systems with very small water volumes.

Assuming that there are no sudden load changes and that the chiller plant has reasonable turndown, a rule of thumb of “gallons of water volume equal to two to three times the chilled water gpm flow rate” is often used.

A properly designed storage tank should be added if the system components do not provide sufficient water volume.

Condenser Water Temperature Control

Condenser water control is an important consideration in chiller plant design since condenser water temperature will directly impact chiller operation and efficiency. When the ambient wet bulb temperature is lower than peak design, the entering condenser water temperature from the cooling tower can be allowed to fall, improving chiller performance. However, operational issues may occur when the condenser water temperatures are either too high or too low. The WME chiller provides several options to assist the chiller plant designer in providing the optimum control of condenser water temperature.

Cooling Tower Control

Control of the cooling tower is required to maintain stability and avoid operational issues. This can be achieved through a BAS or by using the MicroTech controller. For systems utilizing a common condenser water loop for multiple purposes, the BAS contractor must provide the control but use of the MicroTech® output signal is still recommended.

The preferred cooling tower control utilizes a variable speed fan. MicroTech® will provide a control signal to determine the proper fan speed. It can also control up to two stages of fan cycling. Note that fan cycling can cause cooling tower water temperature to fluctuate as fans stage on/off, potentially adding instability to the system.

Each of the following acceptable methods can be controlled by the MicroTech® or through a BAS utilizing the MicroTech® output signals:

1. Three-Way Bypass Valve Operation

A traditional method for building condenser pressure at startup with colder condenser water is with the use of a three-way bypass valve. The device blends warmer water leaving the condenser with cooler water from the cooling tower at the condenser inlet. The bypass valve position will change until full flow from the tower to the condenser is obtained. The MicroTech® provides only the valve position control signal. Main power to drive the valve's actuator must be provided by the installer. The three-way valve should be located close to the chiller within the equipment room to minimize the volume of water.

2. Two-Way Valve Operation

Another condenser control method is to use a modulating two-way control valve located on the outlet connection of the condenser. The valve will be nearly closed at startup to restrict water flow, which keeps generated heat in the condenser until an acceptable minimum condenser pressure is reached. As heat builds, the valve will open slowly until a full flow condition from the cooling tower is established. A separate power source is required to provide power to the valve actuator.

NOTICE

To ensure proper operation, caution should be used when utilizing the two-way valve option.

3. VFD Operating with a Condenser Water Pump

A third method of condenser control for startup is utilizing a variable frequency drive with the condenser water pump. The speed will change as directed by the MicroTech® output signal until design flow is reached. Speed adjustments may be required during the initial chiller startup as determined by the service technician.

NOTICE

Not using the MicroTech logic to control valves and variable frequency drives may result in system instability and capacity reduction.

Condenser Pump Sequencing

It is recommended to utilize the logic built into the MicroTech controller to start the condenser pump. MicroTech has the capability to operate a primary pump and a secondary standby pump. The condenser water flow should be stopped when the chiller shuts off. This will conserve energy and prevent refrigerant from migrating to the condenser. Moisture in the air can condense on the cooler surfaces of the un-insulated condenser barrel if flow is present when the chiller is idle.

Water Side Economizer Cycle Operation

The WME-C vintage chiller is capable of inverted duty operation, meaning the chiller has the capability to accept entering condenser water lower than the leaving evaporator water temperature. In doing so, it extends the range of applications of the chiller and can eliminate the waterside economizer from the system.

The savings resulting on the inverted operation can be quantified with the elimination of the waterside economizer, while also retaining the ability of the chiller to address cooling needs during low ambient temperatures. ASHRAE 90.1 prescribes to include a waterside economizer; so when it is removed, a performance-based compliance path using energy modeling must be followed in order to confirm compliance to the code.

If it is confirmed that a waterside economizer is beneficial to a particular system, the BAS contractor will need to provide controls for the heat exchanger including isolation valves and temperature control. The BAS contractor will also need to control the isolation valves for the chiller. It is important to use slow-acting type valves to prevent rapid changes in system flows. Changeover from economizer cooling to mechanical cooling requires one of the methods previously mentioned to maintain suitable condenser head pressure.

Contact your local Daikin Applied representative for more information on this application.

Human Machine Interface (HMI)

The HMI is turned on/off with a switch located at the lower right-hand edge of the display panel. Screen control buttons are located to either side of it and elicit on-screen prompts when pressed. The HMI is equipped with a screen saver (a blank, black screen). If the screen is black, touch it first to be sure it is on before using the ON/OFF button.

Chiller Operation Without the HMI

The Human Machine Interface (HMI) communicates with the embedded Chiller PC, displaying data and transmitting touch screen inputs to the controllers. The HMI does no actual controlling and the chiller can operate without it. Should the Touch Screen become inoperable, no commands are necessary for continuing unit operation. All normal inputs and outputs will remain functional. A PC monitor and USB mouse can be connected to the Chiller PC via its display port and can be used to view operational data, to clear alarms, and to change setpoints, if necessary.

If the HMI and the chiller both appear to be inoperable, the embedded Chiller PC should be checked since it is required for the chiller to run.

Navigation Summary

The Home View Screen, see [Figure 26](#), is the main information page for the chiller. This screen contains the AUTO and STOP buttons in the upper right-hand corner, which are used to start and stop the unit when in “User” control mode. Other groups of screens can be accessed from the Home View Screen by pressing one of the icons on the bottom of the screen.

An initial startup step may be to select the Operator icon on the bottom right of the HMI to access the Operator screen ([Figure 25](#)) to set display language and unit of measure preferences as well as input the appropriate level of password for making unit adjustments going forward. Should the touch screen cursor not respond to where the screen is being pressed, use the Calibrate button to recalibrate the screen. The Calibrate button is oversized to make it easier for the non-calibrated cursor to select.

Figure 25: Operator View Screen

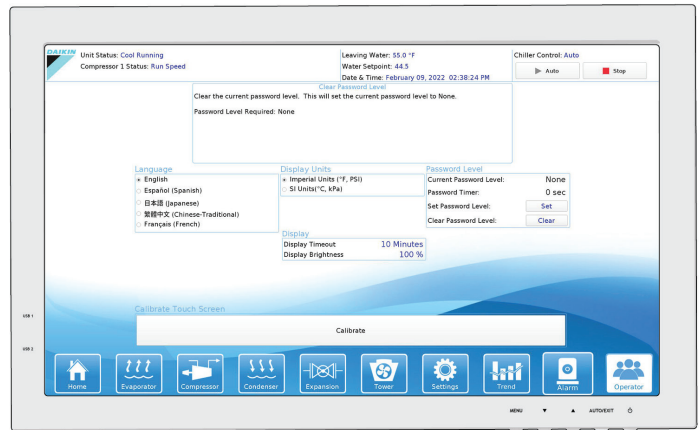

Home View Screen

Figure 26: Home View Screen



The Home View Screen shows the basic operating condition of the chiller. Note that the chiller displayed on all screens will be representative of the actual chiller, showing either one or two compressors depending on the chiller model. Other unit options and order details are not specific to the HMI image.

(I) Consistent Information

The top banner across all screens will always show the following:

- Actual leaving water temperature
- Chilled water setpoint
- Date and Time
- Chiller Control Source
- Unit Status - the possible status combinations are shown in [Table 12](#)
- Compressor Status, shown for each unit compressor (#1 only for single compressor units, both #1 and #2 for dual compressor units), The possible states are shown in [Table 13](#)

The bottom icon bar will be visible on all screens with the active screen highlighted in white.

(II) Unit Status Modes

Defined by Mode followed by State. If the unit is stopped, the Source would be listed after State. Various unit states and control sources are shown as examples in [Figure 27 to Figure 29](#).

Figure 27: Mechanical Switch Source

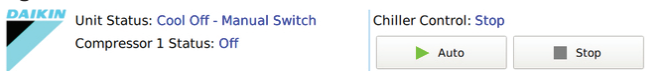

Figure 28: Digital Remote Switch Source

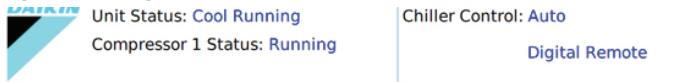

Figure 29: BAS Network Source

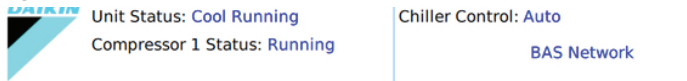

Table 12: Unit Status Possibilities

Off - Manual Switch
Off - HMI (Local)
Off - Remote Switch
Off - BAS Network
Starting
Running
Shutdown
Tandem

Table 13: Compressor Status Possibilities

Off
Pre-Start
Starting
Running
Run IGV
Run Speed
Run Hold
Lead Staging
Run IGV/Speed
Tandem Staging
Power Fail Detected
Pre-Shutdown
Shutting Down

(III) Additional Home View Trend Data Graphs

- Entering and leaving evaporator water temperatures
- Entering and leaving condenser water temperatures
- Percent compressor speed
- Compressor kW

(IV) Alarm

- The ALARM icon will turn red and begin flashing should an alarm occur. This red ALARM button will appear on all screens in the case of an alarm. See [Figure 30](#) for an example of an active alarm alert. For more information on alarms, see [page 41](#) through [page 43](#).

Figure 30: Active Alarm Icon



Additional HMI View Screens

Pressing the Detail Tab on the top of the Home View Screen provides specific unit operating parameters. Similarly, the Power Tab will show current, voltage, and power information for each compressor as well as the unit, see [Figure 32](#).

The HMI screens for the four main components will highlight the relevant portion of the chiller and provide additional information not found on the Home screens. Similarly, the cooling tower information is shown on [Figure 37](#).

To make setpoint adjustments or change operating parameters, tap on the Settings icon at the bottom of the screen, see [Figure 38](#) on page 32.

Figure 31: Unit Detail View Screen



Figure 32: Power Information

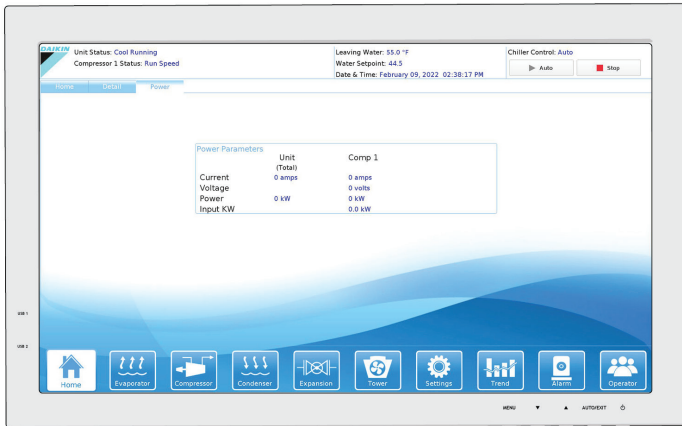

Figure 33: Evaporator Information

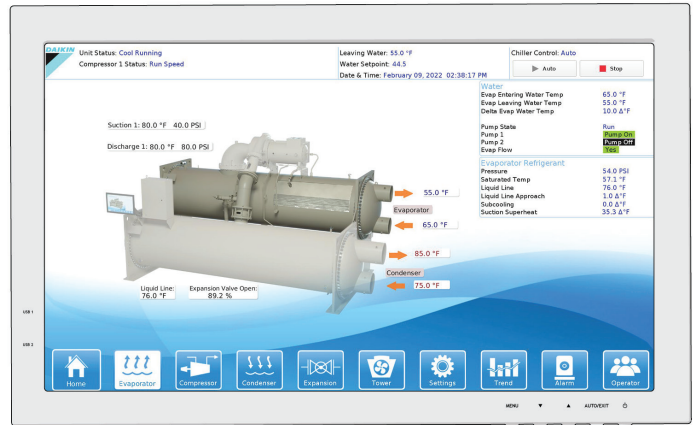
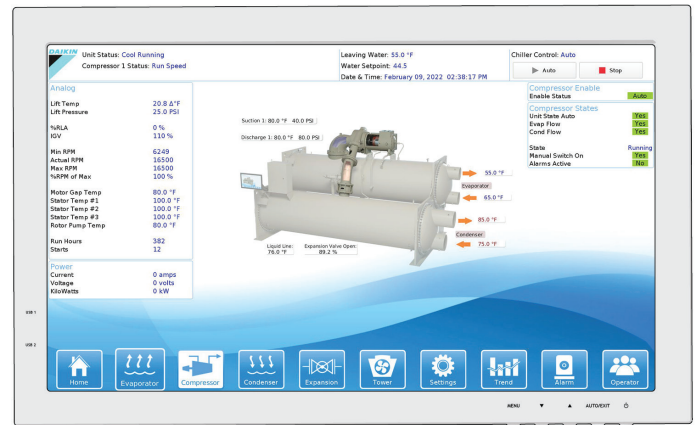

Figure 34: Compressor Details



The Compressor State Information on the right side of the screen is a compilation of events the chiller sequences through at startup. A green light indicates that a particular sequence requirement has been satisfied. It is recommended that this information be viewed during the startup sequence. One can see the requirements light up as they are met and also determine why a non-start may have occurred. Similarly during the shut down process, the sequence transitions back to "Off" and the highlight color will switch to black.

The left-side information displays the status of the compressor in greater detail than on the Home Detail screen ([Figure 31](#)). Compressor related setpoint adjustments can be made within the Settings screen on the Modes and Motor tabs.

Figure 35: Condenser Information

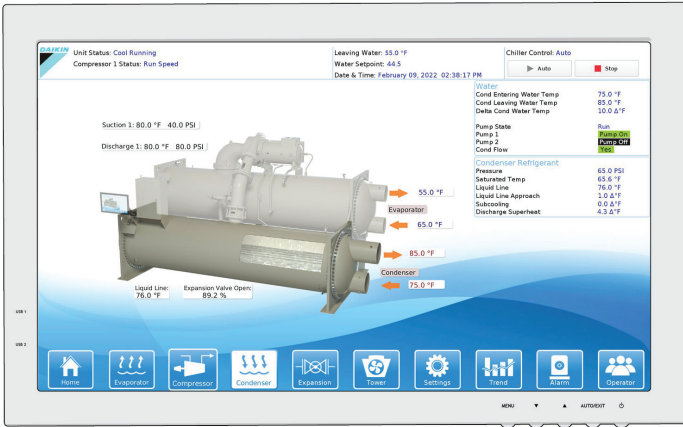

Figure 36: Expansion Valve Information



Figure 37: Cooling Tower Information



NOTE: Selection and setup of cooling tower control methods is in the Settings icon, Tower tab, see Figure 43 on page 35.

SET Screens

Figure 38: A Typical Setpoint Screen

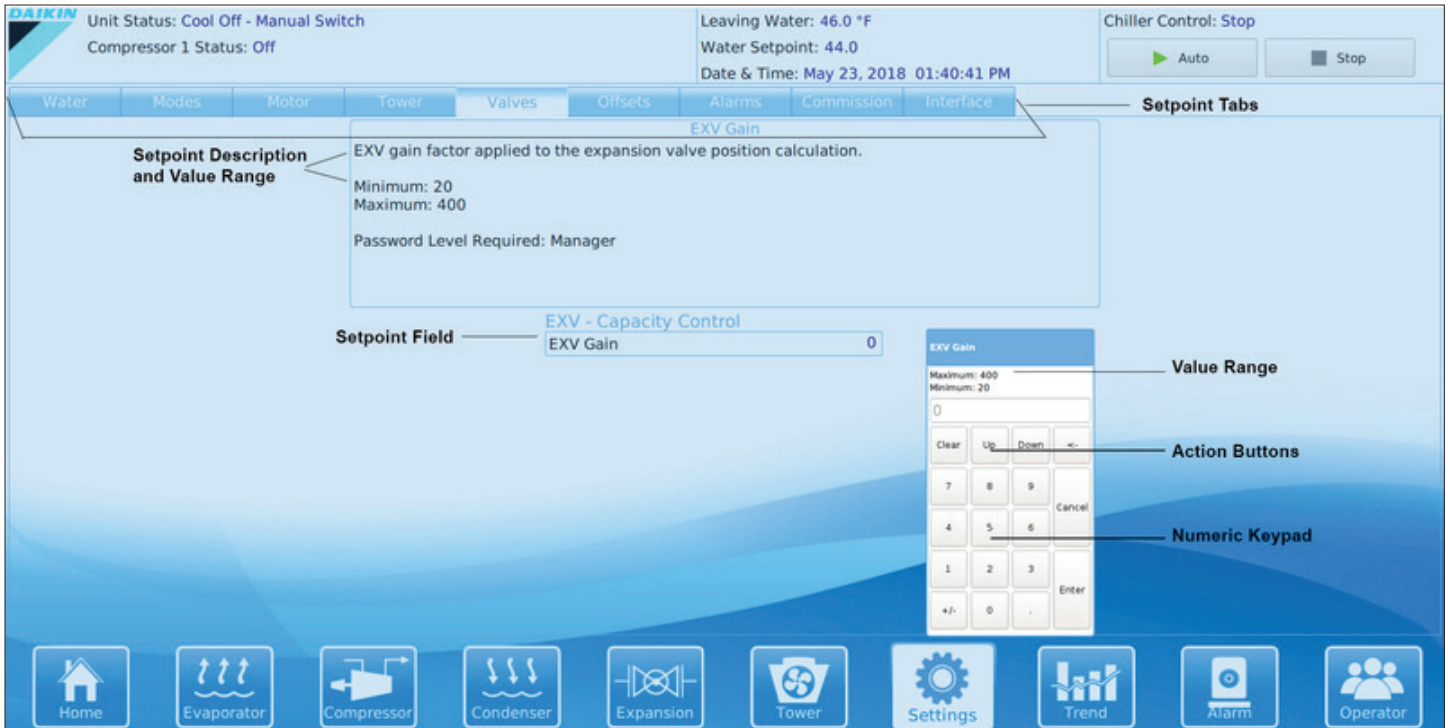

The Setpoint Screens on the HMI are used to input the various setpoints associated with equipment of this type. (Note that if the HMI is unavailable, setpoints can be changed by connecting a laptop.) Appropriate setpoints are factory set and checked by a Daikin Applied service representative during commissioning; however, adjustments and changes are often required to meet job conditions. Certain settings involving pumps and tower operation are field set.

Pressing the Settings icon found at the bottom of every screen accesses the last Setpoint tab used. There are nine setpoint tabs accessible across the top of the Settings screen:

1. WATER - sets leaving water temperature setpoint, start and stop Delta T, resets, etc.
2. MODES - selects various unit parameters such as liquid injection, timers, pump staging, control source, unit mode, etc.
3. MOTOR - selects power related setpoints such as amp limits.
4. TOWER - selects the method of controlling the cooling tower and sets the parameters for fan staging/VFD.
5. VALVE - sets the parameters for operation of the expansion valve.
6. OFFSETS - adjustment values based on calibration.
7. ALARMS - sets the limit and shutdown alarms.
8. COMMISSION - sets parameters and component configurations.

9. INTERFACE - sets the network protocol and associated options.
10. UPDATER - allows upload of software file updates.

A typical Setpoint Screen is displayed in Figure 38. A list of setpoints along with their default value, available setting range, and password authority can be found in the tables after each Setpoint Screen, starting on page 33. The WATER button, for example, contains various setpoints relating to water temperature setpoints.

In Table 14 and in the rest of the Setpoint tables on the following pages, the letters in the Password column refer to the following:

- M = Manager Level (The password number will be supplied by Daikin Applied service at startup.)
- O = Operator Level (The password number for operator level is 100.)
- T = Technician Level (The password number for technician level is only provided to Daikin Applied technicians.)

Procedure for Changing a Setpoint

1. Press the applicable Setpoint Group.
2. Select the desired setpoint by pressing the numbered Setpoint Field.
3. A password must be entered before changing any setpoint value. A keypad prompt will appear to enter a password and then the keypad or drop down menu will appear to make the desired change.

Input the appropriate password number. There is a small delay between pressing the keypad and recording the entry. Be sure that an asterisk appears in the window before pressing the next number.

4. Setpoints with numeric values can be changed in two ways:
 - Select the desired value by pressing the numbered buttons on the Numeric Keypad.
 - Press the UP or DOWN button to increase or decrease the value displayed.

Some setpoints are selectable text menus rather than numeric values. Select the desired option using the dropdown menu that appears on that particular setpoint. Toggle between choices using the UP or DOWN button. If dashed lines appear in the setpoint window, it means that toggling in that direction can go no further, so reverse direction.

For all of the methods listed above, press ENTER on the Setpoint Screen to enter the value or CANCEL to cancel the transaction. The CANCEL or ENTER buttons must be pressed before another setpoint can be selected.

5. Additional setpoints can be changed by selecting another setpoint on the screen using the Setpoint Selection buttons or by selecting an entirely new group of setpoints using the Setpoint Group buttons.

CAUTION

Many setpoints are interactive. Changes may have an adverse effect on chiller operation. Only trained operators should be allowed to change chiller setpoints.

NOTICE

Setpoints that have a technician level password (T) should only be changed by a Daikin Applied technician. Contact a Daikin Applied service representative for more information.

Figure 39: Settings View - Water

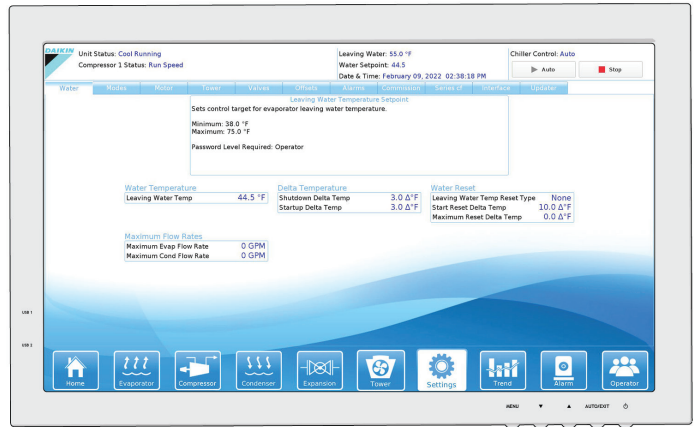

Table 14: Water Setpoints

Description	Default	Range	PW	Comments
Maximum Reset Delta T	0.0°F	0.0 to 20.0°F	O	Reset Type = Return: Sets the maximum LWT reset that can occur. Reset Type = 4-20 mA: Sets amount of reset at 20 mA input.
Start Reset Delta T	10°F	0.0 to 20.0°F	O	Sets evaporator Delta T below which Return reset begins.
LWT Reset Type	None	None Return 4-20 mA	O	Reset raises LWT setpoint Return (uses start Reset Delta T & Max Reset Delta T) 4-20 mA (4 mA=-None, 20 mA=Max as set by Max Reset Delta T)
Startup Delta T	3.0°F	2 to 10.0°F	O	Sets amount leaving water must go above for first compressor to start.
Shutdown Delta T	3.0°F	2 to 6.0°F	O	Sets amount leaving water must drop below setpoint for last compressor to stop.
Leaving Water Temp - Cool	44.0°F	38.0 to 75.0°F	O	Sets control target for evaporator leaving water temperature in COOL mode. 36 °F is lowest setpoint for shutdown.

Leaving Water Temperature (LWT) Reset

The Active Leaving Water variable shall be set to the current Leaving Water Temperature (LWT) setpoint unless modified by one of the reset methods below. (The current LWT setpoint is Cool LWT as determined by the chiller mode.) The type of reset in effect is determined by the LWT Reset Type setpoint.

Reset Type – NONE

The Active Leaving Water variable is set equal to the current LWT setpoint.

Reset Type – RETURN

The Active Leaving Water variable is adjusted by the return water temperature.

When the chiller mode = COOL, the Active Leaving Water variable is reset using the following parameters:

1. Cool LWT setpoint
2. Max Reset Delta T setpoint
3. Start Reset Delta T setpoint

Reset is accomplished by changing the Active Leaving Water variable from the Cool LWT setpoint to the Cool LWT setpoint + Max Reset Delta T setpoint when the evaporator (return – leaving) water temperature delta varies from the Start Reset Delta T setpoint to 0.

Reset Type – 4-20 mA

The Active Leaving Water variable is set equal to the Cool LWT setpoint if the reset signal is less than or equal to 4 mA. It is set equal to (Cool LWT setpoint + Max Reset Delta T setpoint) if the reset signal equals or exceeds 20 mA. The Active Leaving Water variable will vary linearly between these extremes if the reset signal is between 4 mA and 20 mA. An example of this action is shown in Figure 40; temperatures are examples only.

Figure 40: LWT Reset (Cool Mode)

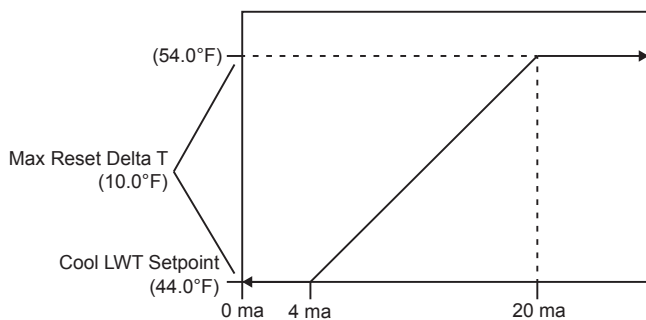

Figure 41: Settings View - Modes

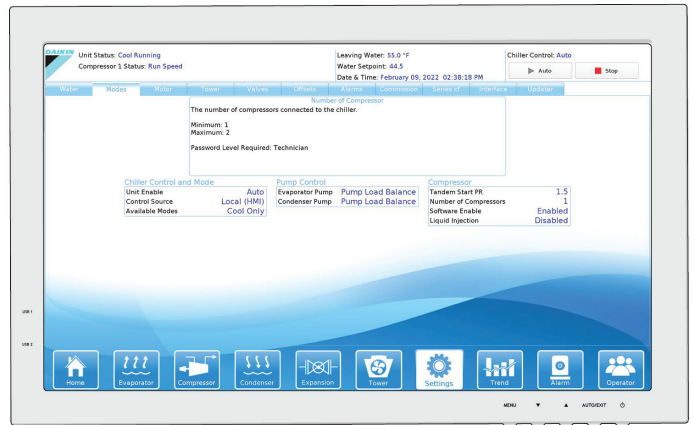

Table 15: Modes Setpoints

Description	Default	Range	PW	Comments
Tandem Pressure Ratio Limit	1.7 for WME092 2.0 for WME106	1-3.5	O	Max pressure ratio for which a lead-lag start will be performed. A higher pressure ratio will trigger a tandem start.
No. of Compressors	1	1 to 2	O	
Software Enable	Enabled	Enabled, Disabled	O	
Liquid Injection	Disabled	Enabled, Disabled	T	
Condenser Pump	Pump Load Balance	None, Pump Load Balance, Pump #1 Only, Pump #2 Only, Pump #1 Primary, Pump #2 Primary	M	Pump Load Balance - balances hours between #1 and #2 pumps, Pump #1 Only, Pump #2 Only - use only specified pump Pump #1 Primary and Pump #2 Primary - if primary pump fails, other pump is used
Evaporator Pump	Pump Load Balance	None, Pump Load Balance, Pump #1 Only, Pump #2 Only, Pump #1 Primary, Pump #2 Primary	M	Pump Load Balance - balances hours between #1 and #2 pumps, Pump #1 Only, Pump #2 Only - use only specified pump Pump #1 Primary and Pump #2 Primary - if primary pump fails, other pump is used

Description	Default	Range	PW	Comments
Control Source	Local (HMI)	Remote Switch, Local (HMI), BAS	O	Sets control source. See "Unit Enabling/Disabling and Overrides" on page 26.
Unit Enable	OFF	OFF, AUTO	O	OFF: everything is off. AUTO: Evap pump on, comp, cond pump and tower on as required to meet LWT
Available Mode	COOL	COOL	O	COOL

Figure 42: Settings View - Motor

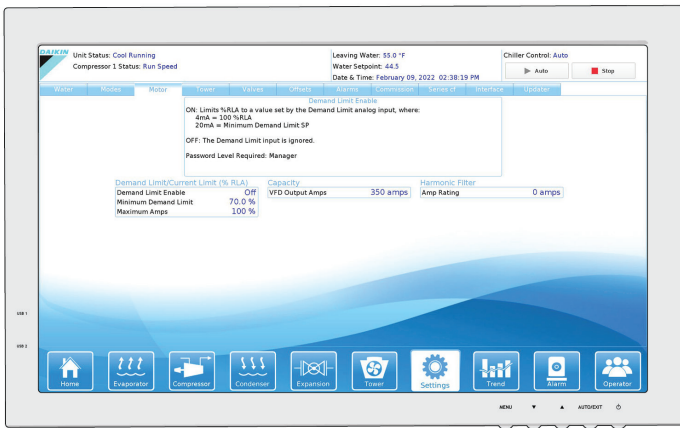

Table 16: Motor Setpoints

Description	Default	Range	PW	Comments
Dual to Single Target	-30	-5 to -100	T	Hysteresis for staging compressors up or down based on the efficiency curves
Single to Dual Target	30	5 to 100	T	
Dual to Single Factor	1.0	0.7 to 1.3	T	Scaling factor when transitioning from dual to single compressor operation
Single to Dual Factor	1.0	0.7 to 1.3	T	Scaling factor when transitioning from single to dual compressor operation
Stage Transition Target	1.0	.8 to 1.2	T	Scaling factor for transitioning compressors based on efficiency curves
Nameplate RLA (VFD Load Side)	Factory set	Model dependent	T	Sets the Rated Load Amps (RLA) per compressor phase as given on the chiller nameplate - Load Side Phase Data.
Maximum Amps	100%	70 to 100%	O	Inhibits capacity increase above %RLA. Unloading forced at 5% above value.

Description	Default	Range	PW	Comments
Demand Limit Enable	OFF	ON, OFF	O	ON: Limits % RLA to a value set by the Demand Limit analog input, where: 4 mA = 100% RLA 20 mA = Minimum Demand Limit Setpoint OFF: The Demand Limit input is ignored.
Harmonic Filter Amp Rating	Factory set	Model dependent	T	Based on model of harmonic filter

CAUTION

Chiller Nameplate RLA **MUST** match chiller dataplate per compressor.

Figure 43: Settings View - Tower

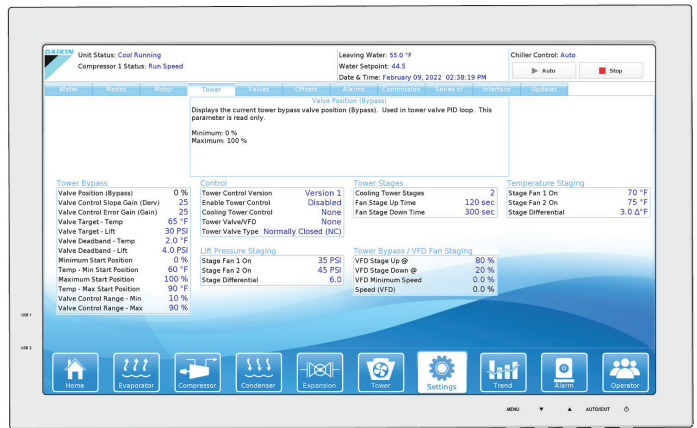

Table 17: Tower Setpoint Settings

Description	Default	Range	PW	Comments
Valve Target - Temp	65	40 – 120	O	Target value for entering condenser water temperature
Valve Target - Lift	30	10 – 100	O	Target value for lift pressure
Valve Control Range - Min	10	0 – 100%	O	Minimum bypass valve position
Valve Control Range - Max	90	0 – 100%	O	Maximum bypass valve position
Tower Control Version	Version 2	None, Version 1, Version 2	T	
Enable Tower Control	Disabled	Disabled, Enabled	O	
Cooling Tower Control	Temp	None, Temp, Lift	O	Selects target for tower bypass and fan control
Tower Fan VFD	None	None, VFD Stage 0, VFD Stage 1, VFD all stages	O	None: No VFD Control VFD Stage 0: VFD independent of fan stage outputs VFD Stage 1: VFD on stage 1 only VFD all stages: VFD on all fan stages
Tower Valve Type	None	None, Normally Closed (NC), Normally Open (NO), VFD	O	None: No bypass valve NC: Valve is normally closed to tower NO: Valve is normally open to tower VFD: bypass valve output controls condenser pump VFD
Tower Control Mode	Auto Efficiency	Manual, Auto, Auto Efficiency	O	Manual: Activate manual control of tower control outputs Auto: Set tower control outputs to reach set point Auto Efficiency: When set point can not be reached, reduce fan output if possible
Response Speed	Slow	None, Slow, Medium, Fast		Tower control output rate of change when not on set point
VFD Minimum Speed	0	0 – 70%	O	Minimum tower fan VFD speed

Description	Default	Range	PW	Comments
Manual Fan Stages	1	0 – 3	O	Set the number of running fan stages when Manual Control is enabled
Manual Fan VFD	50	0 – 100	O	Set fan VFD speed when Manual Control is enabled
Manual Valve / Cond Pump VFD	90	0 – 100	O	Set bypass valve / cond pump VFD when Manual Control is enabled
Cooling Tower Stages	2	1 – 3	O	Number of available tower fan stages

Tower Control Setup

Setup for tower control settings in Table 17 will be accomplished on the HMI using the Tower screen under Settings. See Figure 43. Using the chiller unit controller, up to three digital outputs of tower staging and two analog outputs (0-10 VDC) are available. The two analog outputs are as follows:

1. Bypass Valve or Condenser Pump VFD signal
2. Tower Fan VFD signal

Tower Control Strategies

There are four possible tower control strategies that can be selected with the Cooling Tower Control (Temp, Lift) and Tower Control Mode (Manual, Auto, Auto Efficiency) settings:

1. Manual: Tower control outputs are set to operator configured values.
2. Temp, Auto: Tower control is reactive to the delta between set point and process value (CEWT), and the process value rate of change. This allows the set point to be reached by adjusting tower output over time, if possible, given the cooling tower capability as well as outdoor air temperature and humidity.
3. Lift, Auto: Tower control is reactive to the delta between set point and process value (Lift), and the process value rate of change. This allows the set point to be reached by adjusting tower output over time, if possible, given the cooling tower capability as well as outdoor air temperature and humidity.
4. Temp, Auto Efficiency: Operates the same as Auto, except that when tower fan output is at 100%, after 15 minutes has elapsed, tower fan output is slowly reduced until CEWT increases to find where increasing tower fan output would no longer be effective in reducing CEWT. Fan output control will return to normal if the process value increases by more than 0.2°F or drops below the set point.
5. Lift, Auto Efficiency can be selected but will operate the same as Lift, Auto. Cooling Tower Control by temperature is recommended.

For all strategies, the chiller unit controller can control up to three tower fan stages, as well as a tower fan VFD and either a tower bypass valve or condenser pump VFD. See Figure 43.

Within each variation of the Auto and Auto Efficiency, a PD loop determines a tower capacity loop output (TCLO) value that goes from -100 to 100, where -100 is reducing tower capacity as quickly as possible, 0 is leaving tower capacity unchanged, and 100 is increasing tower capacity as quickly as possible.

- Tower bypass valve
 - steps open above 10 TCLO
 - steps closed below -40 TCLO
- Tower fan on/off events limited in frequency by timers for staging up and staging down
- For a given number N of tower fan stages, all VFD controlled:
 - all stages run at the same speed
 - VFD speed steps up from minimum speed setting to maximum speed setting when above 15 TCLO and tower bypass valve position is > 90% of Valve Control Range - Max
 - VFD speed steps down below -5 TCLO
- For a given number N of tower fan stages, where one stage is VFD controlled:
 - VFD speed steps up from minimum speed setting to maximum speed setting above 0 TCLO and tower valve > 90% of Valve Control Range - Max
 - speed steps down below 0 TCLO
 - VFD speed -100%/N stages when adding 2nd and or 3rd stage
 - VFD speed +80%/N stages when dropping 2nd and or 3rd stage
- For one tower fan stage
 - turn on at 90 TCLO if tower bypass valve position is > 90% of Valve Control Range - Max
 - turn off at 20 TCLO
- For multiple tower fan stages:
 - (E)nable threshold = 90 / N stages
 - (D)isable threshold = 20
 - For 2 stages:
 - • 1 on E*1 TCLO and tower valve > 90%, 2 on E*2 TCLO and tower valve = 100%
 - • 2 off D*2 TCLO, 1 off D*1 TCLO
 - For 3 stages:
 - • 1 on E*1 TCLO and tower valve > 90%, 2 on E*2 TCLO and tower valve = 100%, 3 on E*3 TCLO and tower valve = 100%
 - • 3 off D*2 TCLO, 2 off D*1 TCLO, 1 off D*.5 TCLO

Figure 44: Chiller Unit Tower Control

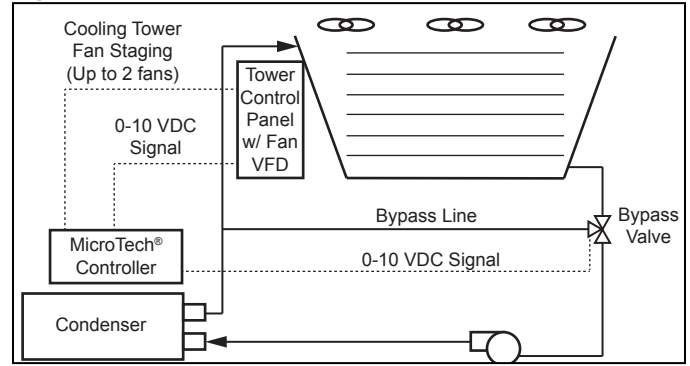

BAS Tower Control

In the above control strategies, the chiller unit controller is directly controlling the cooling tower fan stages, variable frequency drives, and bypass valve. As an alternative, a BAS can control these components based on the 0-10 VDC signals for the tower fan VFD and tower bypass valve or condenser pump VFD. See Figure 45.

Figure 45: BAS Tower Control

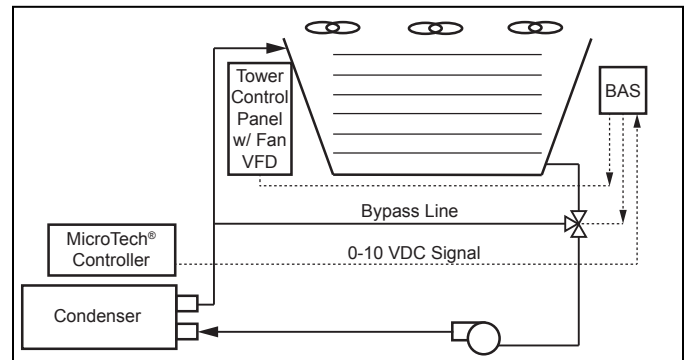

Figure 46: Settings View - Valves

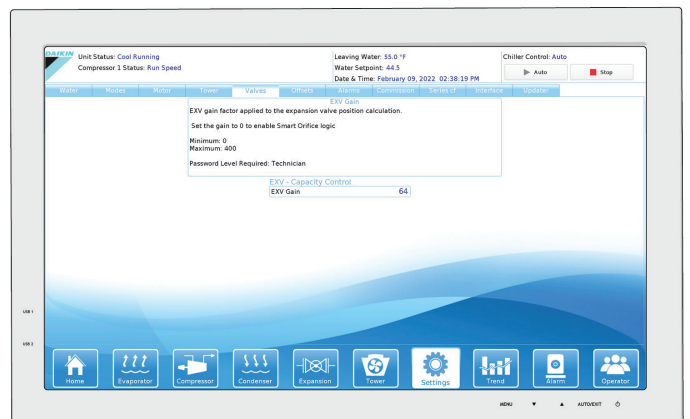

Table 18: Valve Setpoint Settings

Description	Default	Range	PW	Comments
EXV Gain	78	20-400	T	Gain selection based on chiller size and valve type.

Figure 47: Settings View - Offsets

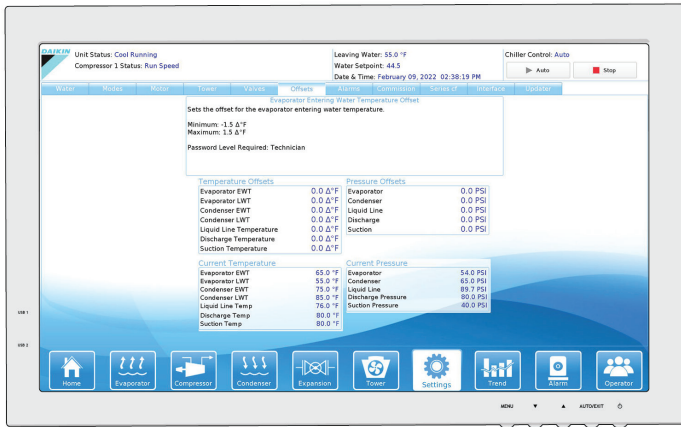

Table 19: Offsets Setpoint Settings

Description	Default	Range	PW	Comments
Evap EWT	0.0	-1.5 to 1.5	T	Sets the offset for the sensor listed based upon jobsite calibrations.
Evap LWT	0.0	-1.5 to 1.5	T	
Cond EWT	0.0	-1.5 to 1.5	T	
Cond LWT	0.0	-1.5 to 1.5	T	
Liquid Line Temp	0.0	-1.5 to 1.5	T	
Comp Discharge Temp	0.0	-1.5 to 1.5	T	
Comp Suction Temp	0.0	-1.5 to 1.5	T	
Evap Pressure	0.0	-2 to 2	T	
Cond Pressure	0.0	-2 to 2	T	
Liquid Line Pressure	0.0	-2 to 2	T	
Comp Discharge Press	0.0	-2 to 2	T	
Comp Suction Press	0.0	-2 to 2	T	

Figure 48: Settings View - Alarms

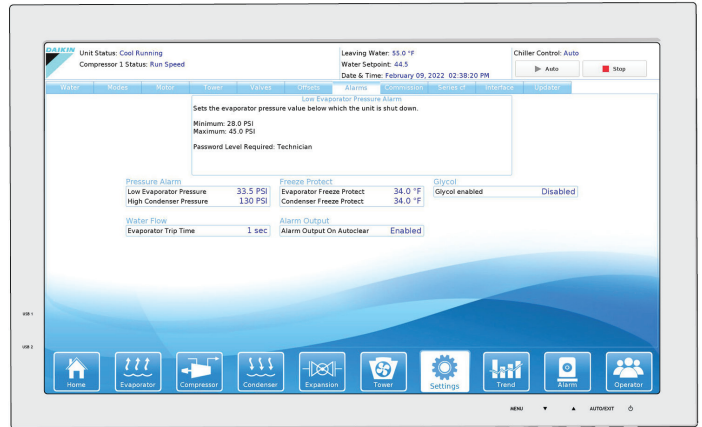

Table 20: ALARMS Setpoint Settings

Description	Default	Range	PW	Comments
Condenser Freeze Protect	34.0°F	34.0 to 45.0°F	T	Sets the value of condenser saturated temperature below which the condenser pump is forced ON - occurs when unit is off and chiller senses need to provide flow to address a chiller limit alarm - see "Critical Alarms" on page 42
Condenser Freeze Protect with Glycol	34.0°F	-9.0 to 45.0°F	T	Sets the value of condenser saturated temperature below which the condenser pump is forced ON - occurs when unit is off and chiller senses need to provide flow to address a chiller limit alarm - see "Critical Alarms" on page 42
Evaporator Freeze Protect	34.0°F	34.0 to 45.0°F	T	Sets the value of evaporator saturated temperature below which the evaporator pump is forced ON - occurs when unit is off and chiller senses need to provide flow to address a chiller limit alarm - see "Critical Alarms" on page 42
Evaporator Freeze Protect with Glycol	34.0°F	-9.0 to 45.0°F	T	Sets the value of evaporator saturated temperature below which the evaporator pump is forced ON - occurs when unit is off and chiller senses need to provide flow to address a chiller limit alarm - see "Critical Alarms" on page 42

Low Evaporator Pressure	29 psi	28 to 45 psi	T	Sets the evaporator pressure value below which the compressor is shut down - may need to be lowered if glycol is added to the system. If Glycol Enabled is selected, minimum may be set as low as 20 psi.
Low Evaporator Pressure (R513A)	33.7 psi	32.7 to 50.6 psi	T	Sets the evaporator pressure value below which the compressor is shut down - may need to be lowered if glycol is added to the system. If Glycol Enabled is selected, minimum may be set as low as 24.1 psi.
Low Evaporator Pressure (R-515B)	17.4 psi	16.7 to 29.4 psi	T	Sets the evaporator pressure value below which the compressor is shut down - may need to be lowered if glycol is added to the system. If Glycol Enabled is selected, minimum may be set as low as 10.7 psi.
High Condenser Pressure (R-134a)	140 psi	130 to 175 psi	T	Sets the condenser pressure limit R-134a
High Condenser Pressure (R-513A)	150 psi	130 to 175 psi	T	Sets the condenser pressure limit R-513A
High Condenser Pressure (R-515B)	115 psi	83 to 128 psi	T	Sets the condenser pressure limit R-515B
Evaporator Trip Time	1 sec	0 to 5 sec	T	-

CAUTION

Changing setpoint below 28 psi minimum requires glycol to be added to the system otherwise there is a risk of freezing the evaporator.

Figure 49: Settings View - Commission

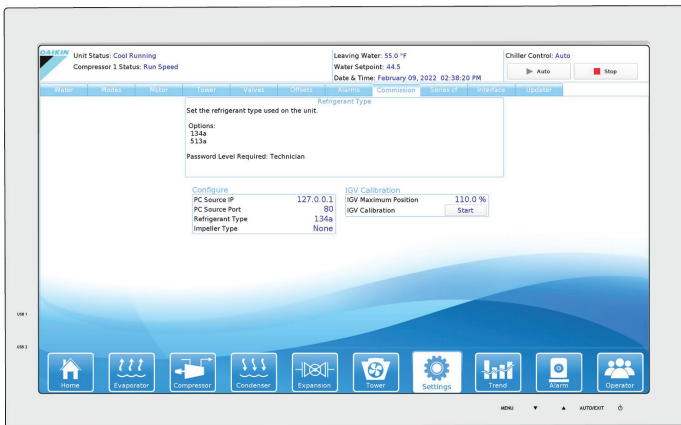

Table 21: Commission Setpoint Settings

Description	Default	Range	PW	Comments
Impeller Type	Factory set	092X, 092Y, 106X, 106Y	T	Size of compressor and impeller type - see Compressor Usage, Table 6
IGV Maximum Position	100%	90-110%	T	100% indicates vanes are straight

NOTICE

If both compressors have the same sequence number, they will automatically balance starts and run-hours. User cannot manually stage compressors as this is an internal process.

Figure 50: Settings View - Interface

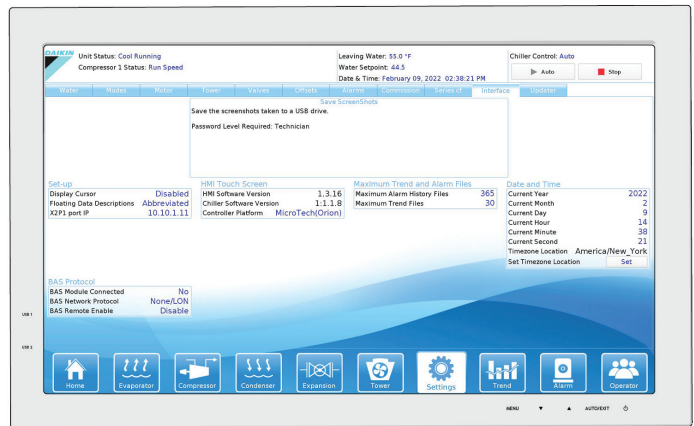

Table 22: Unit Interface Settings

Description	Default	Range	PW	Comments
BAS Network Protocol	NONE	NONE, MODBUS, LONWORKS, BACnet IP, BACnet MS/TP	O	NONE: No BAS network MODBUS: RTU - RS485 LONWORKS: LONtalk - FTT-10A BACnet IP: IP - Ethernet BACnet MS/TP: RS485

NOTICE

It is likely that the chiller will contain the factory settings for date and time; therefore, it is important to verify or change these settings when the chiller is first used on the jobsite. Failure to do so will result in incorrectly labeled History files.

The version numbers shown towards the bottom left of the screen are the controllers' software identification. These numbers may be required by Daikin Applied to answer questions about unit operation or to assist in possible future upgrades of software.

Compressor Capacity Control

Compressor capacity is determined by the status of the leaving chilled water temperature (LWT), which is a direct indicator of whether the chiller is producing enough cooling to satisfy the cooling load. The LWT is compared to the active chilled water setpoint, and compressor loading or unloading ensues, considering any capacity overrides that may be in effect.

Capacity Overrides

The conditions described in the following subparagraphs override normal capacity control. Of the following limits, the one creating the lowest capacity limit is in effect.

Low Evaporator Pressure

If the evaporator pressure approaches within 2 psi above the Low Evaporator Pressure setpoint, the unit will inhibit capacity increases. If the evaporator pressure approaches within 1 psi above the Low Evaporator Pressure setpoint, the unit may unload if chiller conditions necessitate it.

High Motor Temperature

If the highest motor stator temperature is above the limit, the unit will adjust capacity to keep the temperature within the limits.

Demand Limit

The maximum amp draw of the compressor(s) can be limited by a 4 to 20 mA signal on the Demand Limit analog input. This function is only enabled if the Demand Limit Enable setpoint is set to ON. The amp limit decreases linearly from the 100% Limit (at 4 mA) to the Minimum Amp Limit setpoint (at 20 mA). While this override is in effect, chiller capacity is continuously adjusted to keep the % RLA near the requested demand limit.

Network Limit

The maximum amp draw of the compressor(s) can be limited by a value sent through a BAS network connection and stored in the Network Limit variable. While this override is in effect, chiller capacity is continuously adjusted to keep the % RLA near the requested demand limit.

Maximum Amp Limit

The maximum amp draw of the compressor(s) is always limited by the Maximum Amps setpoint. This limit has priority over all other functions including manual capacity control. While this override is in effect, chiller capacity is continuously adjusted to keep the % RLA near the limit value.

Figure 51: Settings View - Updater

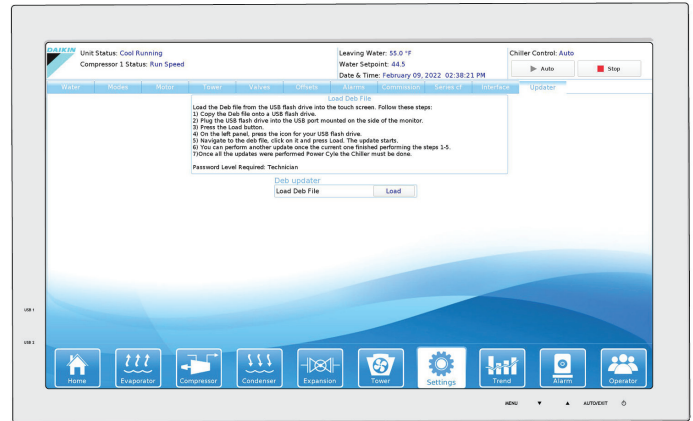

Trend History Screen

The Trend History Screen (Figure 52) is accessed by clicking the TRENDS button at the bottom of any screen. The Trend History Screen allows the user to view the various parameters listed on the right side of the screen.

The Trend History Screen can display history for 24-hour, 4-hour, 1-hour, or 20-minute periods by pressing the appropriate button, respectively. For any time period, the trend will display the current time beginning on the right of the screen with history flowing to the left.

When the Unit Control Processor is powered on after being off, the Trend History Screen will only display the history starting from the time the Unit Control Processor was powered on. Previous trend history can be downloaded but there will be a gap in the data from when the Unit Control Processor was off. Trend history is not affected if only the HMI screen (not the Unit Control Processor) is off or in sleep mode. For details on how to download the trend history, reference page 40.

Figure 52: Trend History Screen



Alarms

The Alarm information (Figure 53 and Figure 54) is accessed by touching the ALARM icon at the bottom of the HMI and then the Active or History tabs at the top of the screen. As noted on page 29, an active alarm will turn the icon flashing red.

There are two types of alarms:

1. **Critical Alarm (Red)** - This is an equipment protection alarm that will shut a unit or compressor off if not corrected.
2. **Warning (Yellow)** - This alarm limits compressor loading in response to an out-of-normal condition or may only be a notification to indicate that the condition requires attention. This alarm may not cause a shutdown. If the condition that caused a warning is corrected, the alarm light will be cleared automatically.

The Alarm Active and History Screens display a maximum of 18 alarms for the current date with the most current alarms listed on top. Each alarm displays the date stamp, action taken, and the cause of the alarm. See the Alarm tables starting on page 42 for specifics on alarms that may occur. Alarm history data is held for 365 days as shown on the Interface tab in Figure 50.

Digital Alarm Output

On the field wiring diagram there is an option for the customer to wire to a digital alarm output. There is both a normally closed (NC) and normally open (NO) option depending on if the customer wants a contact that opens on alarm (NC) or a contact that closes on alarm (NO). Alarm state will maintain until the alarm is cleared. Note that by default the digital alarm output will trigger on all critical alarms, including critical alarms that are displayed as warnings and auto-cleared. Changing the Alarm Output on Auto Clear HMI setting to false will suppress the digital alarm output for auto-cleared critical alarms that are able to be cleared automatically.

Clearing an Alarm

There are two different indicators that the chiller will generate when conditions arise that are affecting the chiller operations. Warnings are indicated in yellow on the HMI and communicate that the chiller should be serviced but allow the chiller to keep running. Warnings cannot be cleared manually and will be cleared automatically when the issues has been resolved.

Critical Alarms will always shutoff the chiller and Critical Alarms that do not require external intervention may attempt to auto-clear once conditions return to normal (Pressure and Temperature Alarms). Auto-cleared Critical Alarms will be yellow and will be displayed as warnings unless there has been 3 within the hour. After 3 alarms occur within the hour, the Critical Alarm will be displayed as a Critical Alarm by being indicated in Red on the HMI and will prevent the chiller from running until manually cleared via the HMI or BAS/SiteLine. Critical Alarms that require external intervention (Communication and Sensor Alarms) will immediately show up as Red Alarms on the HMI and prevent the chiller from running until manually cleared via the HMI or BAS/SiteLine, after the condition has been resolved.

Repeated manual clearing of Critical Alarms via the HMI or the BAS without resolving the cause of the Alarm may damage the chiller and void the chiller warranty.

Although the Alarm History Screen only displays the most current alarms, a record of ALL alarms is stored in the Unit Control Processor. Note that this record may include alarms that occurred when the chiller was not yet fully assembled in the factory. This record is maintained even if the Unit Control Processor is powered off. When the HMI is powered back on, the last 18 alarms for the current date will show on the Alarm History Screen and all alarm history will still be available for download.

Figure 53: Active Alarm View Screen

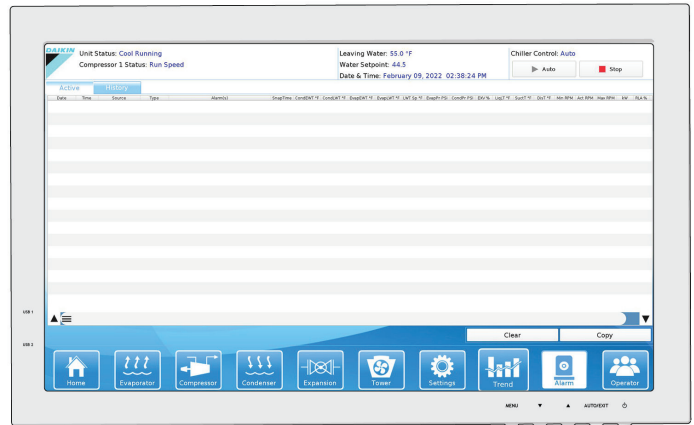
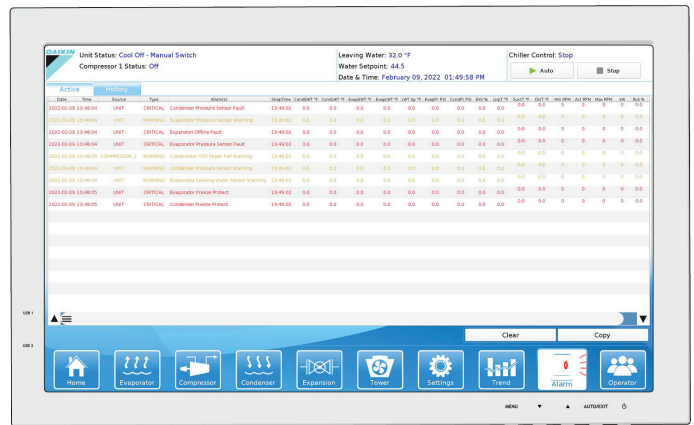

Figure 54: Alarm History Screen



Downloading Trend and Alarm History

The Copy button on the Trend History and Alarm History screens can be used to download the data via USB. In order to download the trend and alarm history:

1. Insert a USB drive into the left side of the HMI panel or directly into embedded HMI PC.

NOTICE

Thirty MB per day should be available on the USB drive that is inserted for the download of the trend and alarm history. There is no warning of insufficient space.

- If an error message that states "Error mounting the USB drive" appears on the HMI, remove and re-install the USB drive. If the problem persists, try a different USB drive. Name brand USB drives are recommended.

NOTICE

Often times, this error message is due to not allowing sufficient time between inserting the USB drive and pressing the Copy button (see Step 4 below).

- After clicking on the "Display Date" button, choose the desired date.
- Press the Copy button. This will download the trend and alarm history for the selected day. (The Unit Control Processor will store 30 days of history at a maximum. The Unit Control Processor will automatically delete old trend history files as needed to make room for new trend history files. Old alarm history files are not deleted.) The HMI will display "download complete" once the history files have been successfully transferred to the USB drive.
- Repeat this process for each desired day of history. Each day must be downloaded individually. It is not possible to download multiple days of history at once.

Viewing/Using Trend History Files:

Trend history files can be recognized by "Trend" at the beginning of the file name followed by the date. For example, if there is a file called "Trend20180623.csv," it indicates that the file contains trend history from 6/23/2018. If the history is downloaded for the current day, there will only be trend history file up to the current hour. No trend history file is created when the chiller is powered off.

Viewing/Using Alarm History Files:

Alarm history files can be recognized by "AlarmHistory" at the beginning of the file name followed by the date. For example, if there is a file called "AlarmHistory20180623.csv," it indicates that the file contains alarm history from 6/23/2018. When the history is downloaded, there will only be one alarm history file per day. This one alarm history file will contain all of the alarms from the selected day. If there were no alarms that day, no alarm history file will appear when the history is downloaded.

All alarm history files are saved from the Unit Control Processor as .csv files. These files can be opened on a normal PC and manipulated using a spreadsheet program.

Requesting Tech Support:

If tech support is requested, ALL of the original, unmanipulated files (Trend.csv and AlarmHistory.csv,) must be sent together to Daikin Applied. Any other file formats are NOT accepted.

Table 23: Critical Alarms

Screen Text	Trigger Condition
Low Evaporator Pressure	Evaporator Pressure (or lowest Suction Pressure if Evaporator Pressure Transducer is detected as bad or disconnected) is less than Low Evaporator Pressure Alarm Setpoint. Causes: Low or No Evaporator Water Flow. Low refrigerant level in evaporator. Incorrect setpoint value for leaving water temperature.
High Condenser Pressure	Condenser Pressure (or Highest Discharge Pressure if Condenser Pressure Transducer is detected as bad or disconnected) is greater than High Condenser Pressure setpoint, see "ALARMS Setpoint Settings" on page 38
Evaporator Pressure Sensor Fault	Evaporator Pressure Transducer and Suction Pressure Transducer(s) are detected as bad or disconnected
Condenser Pressure Sensor Fault	Condenser Pressure Transducer and Discharge Pressure Transducer(s) are detected as bad or disconnected
Evaporator Water Flow Loss	An alarm occurs while Evaporator Flow is not detected. Causes: Loss of evaporator flow, evaporator pump off, evap head gasket leaking or missing, sensor wiring fault, evaporator flow sensor failure
Condenser Water Flow Loss	An alarm occurs while Condenser Flow is not detected. Causes: Loss of condenser flow, condenser pump off, condenser head gasket leaking or missing, sensor wiring fault, condenser flow sensor failure
Evaporator Pump Fault	Evaporator pump does not see flow for 60 seconds after turning on when evaporator pump control is enabled.
Condenser Pump Fault	Condenser pump does not see flow for 60 seconds after turning on when condenser pump control is enabled.
Evaporator Freeze Protect	Saturated Evaporator Temperature is less than Evaporator Freeze Protection Setpoint while chiller is OFF. Causes: Low evaporator water flow rate, low refrigerant in chiller.
Condenser Freeze Protect	Saturated Condenser Temperature is less than Condenser Freeze Protection Setpoint while chiller is OFF. Causes: Low condenser water flow rate, low refrigerant in chiller.
MicroTech OFFLINE Error	The MicroTech on the compressor controller is offline (no comm/power)
MicroTech Configuration Error	The MicroTech on the compressor controller has a configuration error
VFD Communications Fault	Communication between the compressor controller and the VFD are interrupted
MBC Communications Fault	Communication between the compressor controller and the MBC are interrupted
Low Suction Pressure	Suction Pressure is less than Low Suction Pressure setpoint and Suction Pressure Warning is not active
High Discharge Pressure	Discharge pressure > High Discharge Pressure SP. Causes: Low or No Condenser Water Flow
Discharge Temperature High	Discharge Temperature > High Discharge Temperature SP SP. Causes: Low or No Condenser Water Flow

Screen Text	Trigger Condition
High Motor Winding Temperature	One of the motor winding temperatures is greater than 298 F. Causes: Motor stator cooling solenoid not open, rotor cooling stepper motor not functioning correctly, motor rotor superheat or gain setpoints incorrect (contact factory)
High Motor Gap Temperature	Motor Gap Temperature is greater than 130F
Max RLA Exceeded	VFD Output exceeds 115% of Nameplate RLA Setpoint
Motor Gap Temperature Sensor Fault	Motor Gap Temperature Sensor is detected as bad or disconnected
Rotor Pump Temperature Sensor Fault	Rotor Pump Temperature Sensor is detected as bad or disconnected
Motor Winding Temperature Sensor Fault	All Motor Winding Temperature Sensors are detected as bad or disconnected
High Suction Temperature Fault	Suction Temperature is greater than 125F and Suction Temperature Sensor Warning is not active
High Discharge Temperature Fault	Discharge Temperature is greater than 150F and Discharge Temperature Sensor Warning is not active
VFD Fault	A Fault occurs from the VFD
MBC Fault	A Fault occurs from the MBC

Table 24: Warning Alarms

Screen Text	Trigger Condition
Evaporator Pressure Sensor Warning	Evaporator Pressure Transducer is detected as bad or disconnected but there are valid Suction Pressure Transducer(s) detected
Condenser Pressure Sensor Warning	Condenser Pressure Transducer is detected as bad or disconnected but there are valid Discharge Pressure Transducer(s) detected
Motor Case Temperature Sensor Warning	Motor Case Temperature Sensor is detected as bad or disconnected
Motor Winding Temperature Sensor Warning	Two of the Motor Winding Temperature Sensors are detected as bad or disconnected
Suction Temperature Sensor Warning	Suction Temperature Sensor is detected as bad or disconnected
Discharge Temperature Sensor Warning	Discharge Temperature Sensor is detected as bad or disconnected
Suction Pressure Sensor Warning	Suction Pressure Sensor is detected as bad or disconnected
Discharge Pressure Sensor Warning	Discharge Pressure Sensor is detected as bad or disconnected
MBC Warning	A Warning occurs from the MBC

Controller Inputs and Outputs

As outlined below, inputs and outputs vary between the unit controller and the compressor controller.

Unit Controller Inputs and Outputs

The following tables list the unit controller inputs and outputs, both analog and digital, as well as the stepper motor outputs.

Table 25: Unit Controller, Analog Inputs

Description	Wiring	Source	Signal	Sensor Range
Entering Evaporator Water Temperature	Chiller	NTC Thermistor	10k @ 25°C	-40 to 125°C
Leaving Evaporator Water Temperature	Chiller	NTC Thermistor	10k @ 25°C	-40 to 125°C
Entering Condenser Water Temperature	Chiller	NTC Thermistor	10k @ 25°C	-40 to 125°C
Leaving Condenser Water Temperature	Chiller	NTC Thermistor	10k @ 25°C	-40 to 125°C
Liquid Line Refrigerant Temperature	Chiller	NTC Thermistor	10k @ 25°C	-40 to 125°C
Evaporator Refrigerant Pressure	Chiller	Sealed Gage Transducer	0.5 to 4.5 VDC nominal	0 to 100 psi
Liquid Line Refrigerant Pressure	Chiller	Sealed Gage Transducer	0.5 to 4.5 VDC nominal	0 to 200 psi
Condenser Refrigerant Pressure	Chiller	Sealed Gage Transducer	0.5 to 4.5 VDC nominal	0 to 200 psi
Reset of Leaving Water Temperature	Field	BAS	4 to 20 mA Current	0 to 100%
Demand Limit	Field	BAS	4 to 20 mA Current	0 to 100%

NOTICE

“Sensor Range” in Table 25 indicates the range of the input, NOT the operating range of the chiller.

Table 26: Unit Controller, Digital Inputs

Description	Wiring	Signal Source	States (Open/Closed)
Front Panel "Stop/Auto" Switch	Chiller	Isolated Switch Contacts	Stop/Auto
Remote Start/Stop	Field	Isolated Switch or Relay Contacts	Stop/Auto
Evaporator Water Flow Switch	Chiller & Field (in series)	Isolated Flow Switch Contacts	No Flow/Flow
Condenser Water Flow Switch	Chiller & Field (in series)	Isolated Flow Switch Contacts	No Flow/Flow

Table 27: Unit Controller, Analog Outputs

Description	Output Signal	Sensor Range
EXV Driver Signal	0 to 10 VDC	0 to 100% Open
Cooling Tower Bypass Valve Position	0 to 10 VDC	0 to 100% Open
Cooling Tower VFD Speed	0 to 10 VDC	0 to 100%

NOTICE

"Sensor Range" in Table 27 indicates the range of the output, NOT the operating range of the chiller.

Table 28: Unit Controller, Digital Outputs

Description	Load	Rating
Alarm	Indicator Light	240 VAC
Evaporator Water Pump #1	Pump Contactor	240 VAC
Evaporator Water Pump #2	Pump Contactor	240 VAC
Condenser Water Pump #1	Pump Contactor	240 VAC
Condenser Water Pump #2	Pump Contactor	240 VAC
Cooling Tower Fan #1	Fan Contactor	240 VAC
Cooling Tower Fan #2	Fan Contactor	240 VAC

Compressor Controller Inputs and Outputs

The following tables list, for each compressor controller, analog inputs and digital outputs as well as the stepper motor outputs.

Table 29: Compressor Controller, Analog Inputs

#	Description	Source	Signal	Sensor Range
1	Compressor Suction Temperature	NTC Thermistor	10k @ 25°C	-40 to 125°C
2	Compressor Discharge Temperature	NTC Thermistor	10k @ 25°C	-40 to 125°C
3	Suction Refrigerant Pressure	Sealed Gage Transducer	0.5 to 4.5 VDC nominal	0 to 100 psi
4	Discharge Refrigerant Pressure	Sealed Gage Transducer	0.5 to 4.5 VDC nominal	0 to 200 psi
5	Rotor Pump Temperature	NTC Thermistor	10k @ 25°C	-40 to 125°C
6	Inlet Guide Vane Position	Rotary Transducer	1.5 to 2.6 VDC nominal	Closed to Open
7	Motor Winding Temperature 1	NTC Thermistor	10k @ 25°C	-40 to 150°C
8	Motor Winding Temperature 2	NTC Thermistor	10k @ 25°C	-40 to 150°C
9	Motor Winding Temperature 3	NTC Thermistor	10k @ 25°C	-40 to 150°C
10	Motor Case Temperature	NTC Thermistor	10k @ 25°C	-40 to 125°C
11	Motor Gap Temperature	NTC Thermistor	10k @ 25°C	-40 to 125°C

Table 30: Compressor Controller, Digital Outputs

#	Description	Load	Output OFF	Output ON
1	VFD Enable	VFD	Compressor OFF	Compressor ON
2	Liquid Injection	Solenoid (24 VDC, 20 VA max)	No Injection	Injection
3	Stator Cooling	Solenoid (24 VDC, 20 VA max)	Cooling OFF	Cooling ON

Table 31: Compressor Controller, Analog Outputs

Description	Output Signal	Sensor Range
Inlet Guide Vane Driver Position	0 to 10 VDC	0 to 100%
Rotor Cooling Driver Signal	0 to 10 VDC	0 to 100%
PLBV Driver Position	0 to 10 VDC	0 to 100%

Building Automation Systems (BAS)

All MicroTech controllers are capable of BAS communications, providing easy integration and comprehensive monitoring, control, and two-way data exchange with open standard protocols such as LonTalk®, Modbus® or BACnet®.

Daikin Applied unit controllers strictly conform to the interoperability guidelines of the LonMark® Interoperability Association and BACnet® International. They have received LonMark® certification with optional LonWorks® communication module.

Protocol Options

The following protocol options are available:

- BACnet® MS/TP
- BACnet® IP
- LonWorks®
- Modbus® RTU

The BAS communication module can be ordered with the chiller and factory-mounted or can be field-mounted at any time after the chiller unit is installed. Connection to the chiller for all BAS protocols will be at the unit controller. An interface card or module, depending on the protocol being used, will have been factory installed in the unit controller if so ordered, or it can be field installed.

If an interface module was ordered, the appropriate BAS interface installation manual was shipped with the unit. If necessary, contact your local Daikin Applied sales office for a replacement manual or obtain one from www.DaikinApplied.com.

Use with On-Site Generators

All Magnitude Model WME chillers have their compressors operated with variable frequency drives and, if the unit has two compressors, the compressors start sequentially in the normal start/load sequence. These features make Magnitude® chillers especially appropriate for use in applications where they may be required to run with on-site electrical generators. This is particularly true when the generators are used for temporary power when the utility power is lost.

Generator Sizing

Natural gas and diesel generators are sensitive to the peak current loads of the chiller. Although the normal VFD start sequence does not require these peak values of current, certain dynamic conditions such as changes in water flow and temperature or momentary power interruptions can cause high peak electrical currents. Use the electrical data either on the VFD data plate or supplied with the chiller performance rating sheet – obtained from the Daikin Applied sales office – for generator sizing purposes. The referenced data will show the RLA and LRA, which is for each compressor. It is important to size the generator to handle the LRA value.



WARNING

Generator must be sized by an electrical engineer familiar with generator applications.

Transfer Back to Grid Power

Due to the special VFD incorporated in all WME chillers and the system's inherent ride-through capabilities, transfer from grid power to stand-by generator power and back to grid power can be done at any time. The duration of power interruption during the transfer process will determine how the chiller will respond. While the compressor rotor is still spinning at adequate speed, power is generated internally to keep the bearings and all control electronics operating. Power interruptions of various durations will cause different restart scenarios as described below.

1. **Short:** Interruptions of only a few seconds will allow a running compressor to return to operating speed almost immediately. (NOTE: If the operating pressure ratio is high at the time of interruption, there may be a short delay in return to operating speed.)
2. **Medium:** For interruptions that cause the compressor to coast down below about 3500 rpm (but still generating control power), the compressor will continue coasting to a stop, and then restart.
3. **Long:** Once the compressor coasts nearly to a stop, control power is lost and the controllers must reboot normally when either grid power or emergency generator power is reinstated. (NOTE: If the RapidRestore® option is installed, the time required to restart is reduced to only a few seconds).

Startup and Maintenance

Pre-Startup

Inspect the chiller to ensure no components became loose or damaged during shipping or installation including leak test and wiring check. Complete the pre-start checklist at the front of this manual and return to Daikin Applied prior to startup date.

CAUTION

Dyes used for refrigerant leak detection are not tested or recommended for use in Daikin Applied chillers. Use of these products may damage and/or degrade the performance of the equipment and will void the manufacturer warranty

NOTICE

Daikin Applied service personnel or factory authorized service agency must perform initial startup in order to activate warranty. They must return the "WME Centrifugal Equipment Warranty Form" within 10 working days to Daikin Applied as instructed on the form to obtain full warranty benefits.

Flow Switch Installation and Calibration

A thermal dispersion flow switch uses heat to determine flow and therefore must be calibrated during system startup. A thermal dispersion flow switch can be an acceptable replacement for paddle type flow switches and differential pressure switches, but care must be taken regarding wiring.

The thermal dispersion flow switch supplied by Daikin Applied, shown in Figure 1, comes as a two part unit consisting of a flow switch and an adapter labeled E40242 by the supplier.

Figure 55: Thermal Dispersion Flow Switch and Adapter

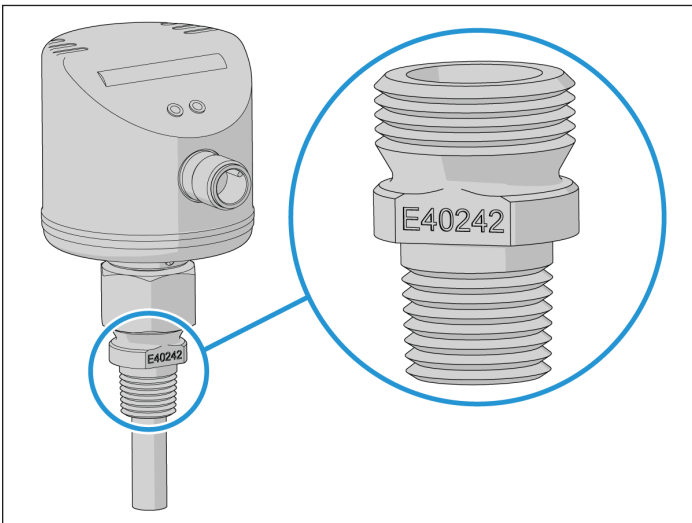

NOTICE

Flow switch **MUST** be calibrated before chiller operation. Failure to properly calibrate the switch may result in severe chiller damage and/or void warranty.

Mounting

Figure 56 highlights the position of the electrical connector and indentation 'mark' on flow switch.

Figure 56: Flow Switch Details

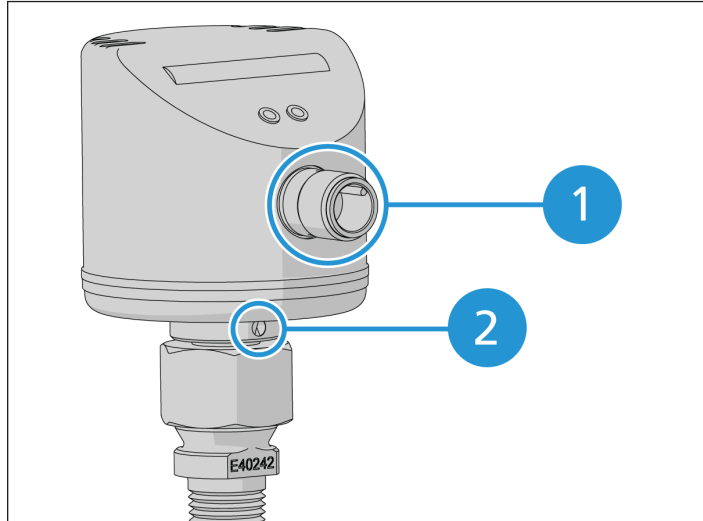

No.	Descriptions
1	Electrical Connector
2	Indentation

It is required that the flow switch be mounted such that the electrical connection and indentation 'mark' are pointed in the direction of flow as shown in Figure 57.

If the flow sensor is to be mounted away from the unit, the sensor should be mounted on the wall of the outlet pipe of evaporator and condenser, or in a run of straight pipe that allows 5 to 10 pipe diameters prior to the sensor and 3 to 5 pipe diameters of straight pipe after the sensor. Flow switch is placed in outlet pipe to reflect flow leaving the barrel. If installation on the inlet pipe is necessary, contact Chiller Technical Response at TechResponse@DaikinApplied.com to review the jobsite details.

Figure 57: Mount in Direction of Flow

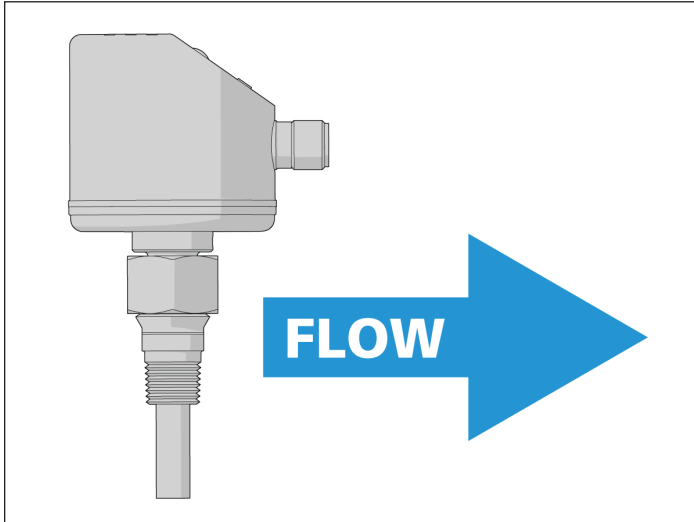

It is important that the flow switch be mounted so that the probe is sufficiently inserted into the fluid stream. Figure 58 illustrates the recommended orientation of the sensor. It may not be mounted directly on top or directly on the bottom of a horizontal pipe.

NOTICE

DO NOT alter or relocate factory installed flow switch. If issues exist, contact Chiller Technical Response at TechResponse@DaikinApplied.com.

Figure 58: Remote Mounting Guidelines for Flow Switch

<p>General</p> <ul style="list-style-type: none"> • The sensor tip is to be completely surrounded by the medium. • Insertion depth of the sensor: minimum .47" in. 		
<p>Recommended</p> <ul style="list-style-type: none"> • For horizontal pipes: mounting from the side. • For vertical pipes: mounting in the rising pipe. 		
<p>To avoid</p> <ul style="list-style-type: none"> • The sensor tip must not be in contact with the pipe wall. • Do not mount in downpipes that are open at the bottom! 		

If needed, the adapter is threaded into the pipe using pipe sealant appropriate for the application. The flow sensor is mounted onto the adapter using silicone grease. Carefully apply lubricant to the inside threads and O-ring so temperature probe does not become coated with lubricant. Torque the adapter/sensor connection to 18.5 ft/lbs.

Wiring

Refer to wiring diagram in the unit control panel.

Either AC or DC is used to power the flow switch. The unit controller's digital input is a DC signal which is supplied through the switch output of the flow switch for flow indication. It is required that the AC and DC commons of power be separated. Contact Chiller Technical Response for alternate wiring scenarios.

Flow Switch Setup

The flow switch comes from the factory set at a default velocity of 20 cm/s. This value is typically well below the minimum water flow specified for the unit evaporator and condenser so field adjustment is required for adequate low flow protection. Table 32 shows the calculated gallons per minute (gpm) for Schedule 40 steel pipe for various fluid velocities from 20 cm/s to 300 cm/s. The flow switch has an overall range of adjustment from 3 cm/s to 300 cm/s.

Step 1: Adjust flow through the evaporator to the minimum desired operating gpm. Maintain this flow throughout the setup procedure.

Step 2: Once steady state minimum desired operating flow is obtained, perform the 'Teach' function on the flow switch. The 'Teach' function is initiated by holding down the minus '-' button on the face of the flow switch for 15 seconds. During this 15 second period, LEDs '0' and '9' will be lit green. Once the 'Teach' function is completed, the outer LEDs will flash green as shown in Figure 59.

Figure 59: Automatic Teach of Setpoint

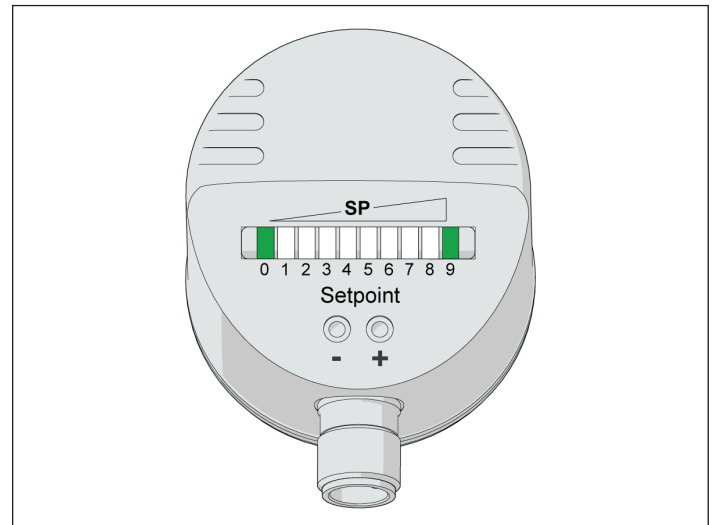
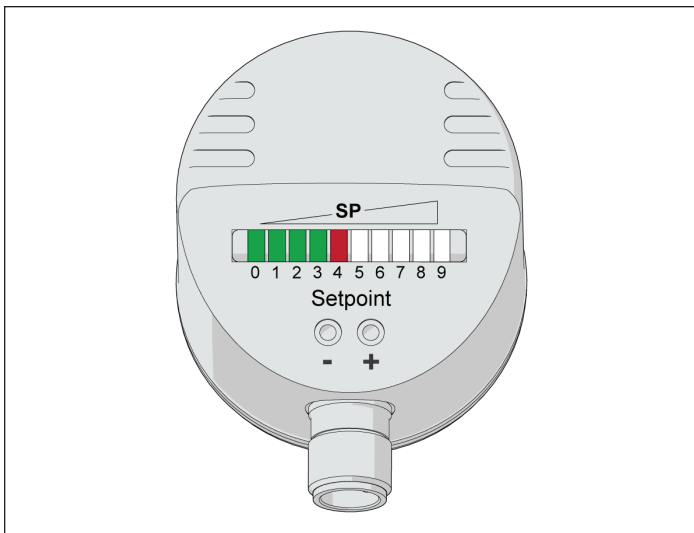

Table 32: Flow Volume Calculation

Pipe Size (inch)	Inside Pipe Diameter (inch)	US GPM at the velocities indicated below									GPM adjustment per '+' or '-' key input
		Default									
		20 cm/sec	30 cm/sec	50 cm/sec	75 cm/sec	100 cm/sec	150 cm/sec	200 cm/sec	250 cm/sec	300cm/sec	
2	2.06	6.86	10.3	17.2	25.7	34.3	51.5	68.6	85.8	102.9	1.72
2.5	2.46	9.79	14.7	24.5	36.7	49.0	73.4	97.9	122.4	146.9	2.42
3	3.07	15.1	22.7	37.8	56.7	75.6	113.4	151.2	189.0	226.8	3.78
3.5	3.55	20.2	30.3	50.6	75.8	101.1	151.7	202.2	252.8	303.3	5.06
4	4.03	26.0	39.1	65.1	97.7	130.2	195.3	260.4	325.5	390.5	6.51
5	5.05	40.9	61.4	102.3	153.5	204.6	306.9	409.2	511.5	613.7	10.2
6	6.07	59.1	88.6	147.7	221.6	295.5	443.2	590.9	738.7	886.3	14.8
8	7.98	102.3	153.5	255.8	383.7	511.6	767.5	1023.3	1279.1	1534.7	25.6
10	10.02	161.3	241.9	403.2	604.8	806.5	1209.7	1612.9	2016.2	2419.1	39.0
12	11.94	229.0	343.4	572.4	858.6	1144.7	1717.1	2289.5	2861.9	3433.8	57.2
14	13.13	276.8	415.2	692.0	1037.9	1383.9	2075.9	2767.8	3459.8	4151.3	69.2
16	15.00	361.5	542.2	903.6	1355.5	1807.3	2710.9	3614.6	4518.2	5421.2	90.4
18	16.88	457.5	686.3	1143.8	1715.7	2287.6	3431.4	4575.2	5719.0	6862.1	114.4
20	18.81	572.4	853.0	1421.6	2132.4	2843.2	4264.8	5686.4	7108.0	8528.6	142.2

Step 3: After the 'Teach' function is completed and the outer LEDs have flashed, the flow switch will indicate a new setpoint based upon the current flow which should still be at the steady state minimum desired operating flow. Figure 60 shows a typical display for this condition. All LEDs to the left of the SP LED are lit green. The SP LED is lit RED (or may toggle amber) which indicates that the flow switch is OPEN. Typically, an increase in fluid flow between 15% to 30% above the 'Teach' function flow is required for the SP LED to turn AMBER and the flow switch to CLOSE indicating acceptable flow.

Figure 60: Teach Adjustment Complete



In Step 3, the 'Teach' function re-adjusted the flow switch SP while flow was at the minimum desired operating flow. The chiller will not operate at this flow because the flow switch is OPEN after performing the 'Teach' function. The benefit of the 'Teach' function is to quickly set the setpoint within the desired operating range. Additional 'manual' adjustment of setpoint is required in order to allow for chiller operation at this minimum flow. The '+' and '-' buttons on the face of the flow switch allow for the manual adjustment of the SP. Pressing the '+' button reduces the flow setpoint while pressing the '-' button increases the flow setpoint. Each button press, '+' or '-', changes the flow setpoint by 2.5 cm/s.

Step 4: Press the '+' button until LED '9' begins to flash, as shown in Figure 61. Opening of flow switch should now occur at approximately 80% to 90% of minimum flow.

Figure 61: Upper Range of Minimum Flow

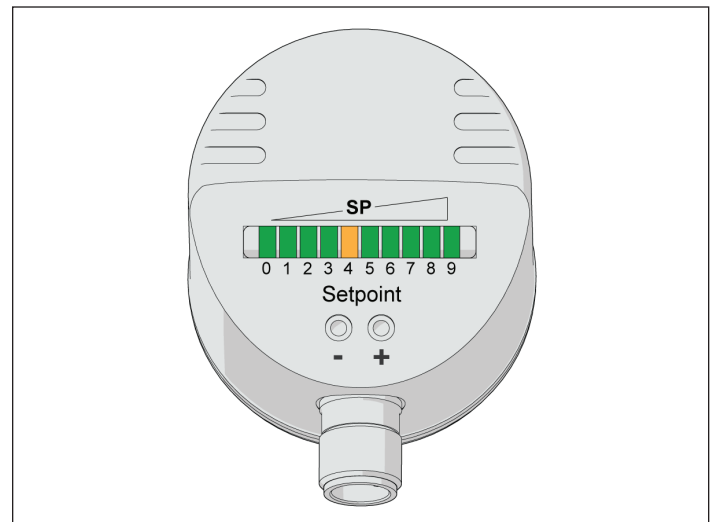

Step 5: Once the SP is set, it is recommended that the sensor be locked to avoid inadvertent readjustment. This can be performed by pressing both the '+' and '-' buttons simultaneously for 10 seconds. The indication goes out momentarily indicating the unit is locked. To unlock, the same procedure is performed to toggle to unlocked.

NOTICE

The LED window display on flow switch represents a velocity range of 50 cm/s. The window centers on the SP. For example, if the SP was set to 200 cm/s, then the LED labeled '0' would represent a velocity of 180 cm/s when lit and the LED labeled 9 would represent a velocity of 230 cm/s when lit.

Each LED represents 5 cm/s, or two presses of the '+' or '-' buttons.

NOTICE

When power is initially applied to the flow switch, all green LEDs light and go out step by step. During this time, the output is closed. The unit is in the operating mode.

When making manual adjustments to the SP, if no button is pressed for two seconds, the unit returns to the operating mode with the newly set value.

Flow below display range: The SP LED will be lit red and the leftmost LED will be flashing green. For example, if the SP was set to 200 cm/s, the flashing labeled '0' would indicate that the flow was below 180 cm/s. This would be shown if no flow through chiller or lowered than desired flow.

Figure 62: Display for Flow Below Range

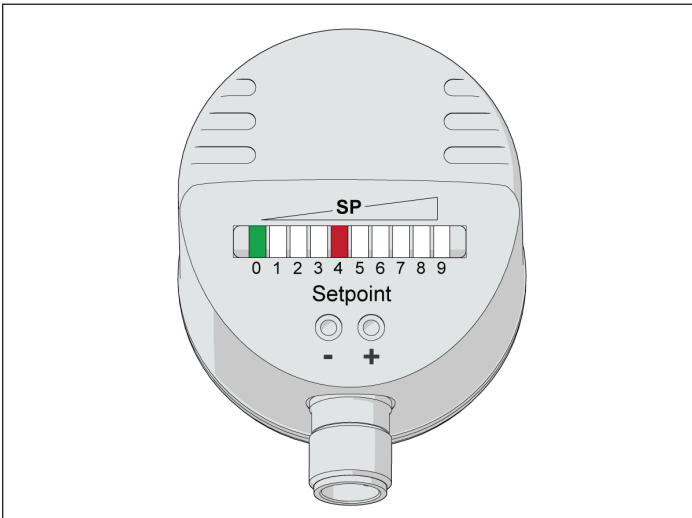

Flow above display range: The SP LED will be lit amber, all LEDs to the left and right of the SP LED will be green with the rightmost LED flashing green. For example, if the SP was set to 200 cm/s, the flashing LED labeled '9' would indicate that the flow was above 230 cm/s. This may be a normal display depending on range by which flow varies through chiller.

Figure 63: Display for Flow Above Range

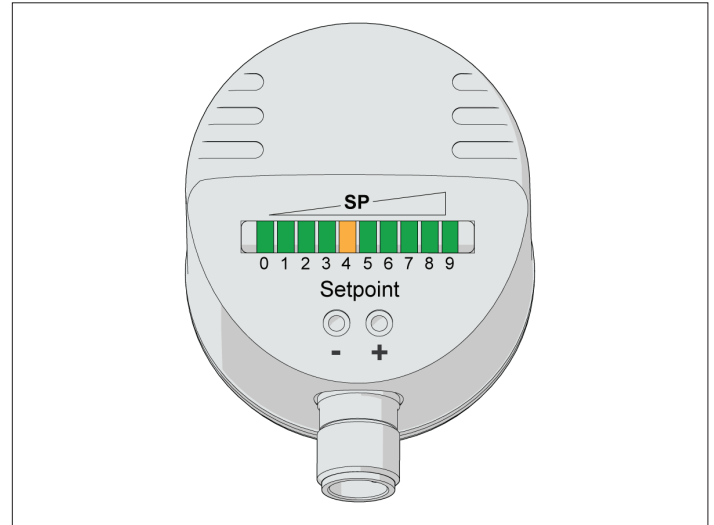

Chiller Maintenance

DANGER

Use approved Lock Out/Tag Out procedures to disconnect power from the unit. Wait 20 minutes after disconnecting power from the unit before opening any compressor access covers. The DC link capacitors store enough energy to cause electrocution.

Electrical System

Maintenance of the electrical system involves the general requirement of keeping connections clean and tight. Pump interlocks and flow switches should be checked to be sure they interrupt the control circuit when tripped.

Cleaning and Preserving

A common cause of service calls and equipment malfunction is dirt. This can be prevented with normal maintenance. The system components most subject to dirt are:

1. Strainers: Remove and clean strainers in the chilled water system and condenser water system at every inspection.
2. Condenser Tubes: Inspect the condenser tubes annually for fouling and clean if required. The standard heads should be removed with care due to their weight. One method for handling standard heads follows (only qualified service personnel should perform these tasks):
 - After draining water, remove all but two head bolts at roughly 10 o'clock and 2 o'clock.
 - Loosen the remaining two bolts to enable the head to be separated from the tube sheet sufficiently for a clevis pin or hook to be inserted into an open bolt hole at the top of the head.
 - Attach a hoist to the pin or hook, lift the head to remove weight from the two remaining bolts, remove the bolts, and carefully remove the head.
 - Do not try to install a machine thread eyebolt into the head vent fitting, which has pipe threads.
 - Reverse this procedure to mount the head, using a new gasket.
3. Condenser Flow Sensor: The condenser sensor should be cleaned anytime the condenser is opened. This should typically be performed at the annual inspection; however, more frequent cleaning may be required depending on the conditions of the jobsite. Recommended maintenance includes the following:
 - Check the sensor tip for buildup.
 - Clean the tip using a soft cloth. Stubborn buildup, such as lime, can be removed using a common vinegar cleaning agent.
4. Electrical Panels: Excessive accumulation of dirt within panels can damage components, inhibit good air circulation, and make visual inspections difficult.

Water Treatment

Special care must be taken when utilizing open system water that is usually not treated (such as lakes, rivers, and ponds). The use of untreated water will result in corrosion, erosion, slime buildup, scaling, or algae formation. Water treatment service must be used. Special tube and water head material may be required to reduce damage from corrosion. Daikin Applied is not responsible for damage or faulty operation from untreated or improperly treated water. "Water Piping" on page 18 for caution statement on water quality.

Seasonal Shutdown

WARNING

The condenser and evaporator are not self-draining. Where the chiller can be subject to freezing temperatures, the condenser and evaporator must be drained of all water. Water permitted to remain in the piping and vessels can rupture these parts if subjected to freezing temperatures. Dry air blown through the vessels will aid in forcing all water out.

Except for freezing conditions, it is desirable to leave water in the vessels to avoid long term exposure to air.

Continuous forced circulation of antifreeze through the vessels is one method of avoiding freeze up.

Seasonal Startup

Seasonal startup procedures are as follows:

1. Leak test the unit.
2. Check and tighten all electrical connections.
3. Replace the drain plugs (including cooling tower pump and tower drain) if they were removed at shutdown the previous season.

Harmonic Filter Evaluation

If the optional harmonic filter is provided with the chiller, measuring the current in each of the three phases of the capacitor circuit may help determine the condition of the capacitors. If the input phase currents are within a 5% match to each other and approximately 30% of filter current rating, the capacitors can be assumed to be in good working condition. Phase currents that are imbalanced, may indicate a capacitor failure. Testing should be done whenever the unit appears to be operating in an abnormal state.

When the unit is off, the harmonic filter may be checked for resistance levels. Using a multi-meter (set to read 100K ohms) to check the phase-to-phase isolation, the reading should be about 40K (total equivalent bleeder resistance value) and should be the same for each phase. Open circuit or very low readings indicate an issue. Also check phase-to-chassis resistance as low readings indicate a ground fault problem.

Maintenance Schedule

Table 33 provides an overview of recommended maintenance procedures along with how frequently these procedures should be performed.

Table 33: Recommended Maintenance Schedule

	Monthly	Quarterly	Semi-Annually	Annually	As Required By Performance	During Seasonal Shutdown	During Seasonal Startup
I. Compressor							
A. Analyze Compressor Fault Log		X					
B. Check IGV operation		X					
C. Check and tighten compressor electrical connections				X			
D. An inspection should be performed on the compressor rotor grounding rod every 5 year				*X			
II. MicroTech Controls							
A. Check for proper settings		X					
B. Verify transducers and sensors for accuracy		X					
C. Retrieve and archive HMI Trend Logs	O						
D. Perform MicroTech® check, log, and last fault analysis		X					
III. Condenser							
A. Confirm correct water flow and pressure drop	O	X					
B. Confirm appropriate water treatment	O						
C. Clean and Leak Test condenser tubes				X	X	X	
D. Eddy Current Test - tube wall thickness					X		
E. Seasonal Protection					X		
F. Clean Flow Sensor				X	X		
IV. Evaporator							
A. Confirm correct water flow and pressure drop	O	X					
B. Confirm appropriate water treatment	O						
C. Clean and Leak Test evaporator tubes					X		
D. Eddy Current Test - tube wall thickness					X		
E. Seasonal Protection					X		
F. Clean Flow Sensor				X			
V. Chiller Unit							
A. Run Test/Performance Evaluation		X					
B. Leak Test entire unit		X				X	X
C. General Appearance:							
1. Paint/Corrosion					X		
2. Insulation					X		
VI. Electrical							
A. Check and record line voltage		X					
B. Inspect power components for signs of overheating		X					
C. Check and tighten unit electrical components				X			X
D. Check all panels for cleanliness - remove dust and debris from electrical boards and connections					X		

Key: O = Performed by owner personnel X = Performed by qualified service personnel

* = 5 year recommendation

Appendix

Temperature/Pressure Chart

Table 34: R-134a Temperature/Pressure Chart

R-134a Temperature/Pressure Chart							
°F	PSIG	°F	PSIG	°F	PSIG	°F	PSIG
6	9.7	46	41.1	86	97.0	126	187.3
8	10.8	48	43.2	88	100.6	128	192.9
10	12.0	50	45.4	90	104.3	130	198.7
12	13.2	52	47.7	92	108.1	132	204.5
14	14.4	54	50.0	94	112.0	134	210.5
16	15.7	56	52.4	96	115.9	136	216.6
18	17.1	58	54.9	98	120.0	138	222.8
20	18.4	60	57.4	100	124.1	140	229.2
22	19.9	62	60.0	102	128.4	142	235.6
24	21.3	64	62.7	104	132.7	144	242.2
26	22.9	66	65.4	106	137.2	146	249.0
28	24.5	68	68.2	108	141.7	148	255.8
30	26.1	70	71.1	110	146.3	150	262.8
32	27.8	72	74.0	112	151.1	152	270.0
34	29.5	74	77.1	114	155.9	154	277.3
36	31.3	76	80.2	116	160.9	156	284.7
38	33.1	78	83.4	118	166.0	158	292.2
40	35.0	80	86.7	120	171.1	160	299.9
42	37.0	82	90.0	122	176.4	162	307.8
44	39.0	84	93.5	124	181.8	164	315.8

Pre-Start Checklist

Must be completed, signed and returned to Daikin Applied service dept. at least 2 weeks prior to requested start date.

Job Name				
Installation Location				
Customer Order Number				
Model Number(s)				
G.O. Number(s)				
Chilled Water	Yes	No	N/A	Initials
Piping Complete				
Water System – flushed, filled, vented; Water treatment in place				
Pumps installed and operational (rotation checked, strainers installed and cleaned)				
Controls operational (3-way valves, face/bypass dampers, bypass valves, etc.)				
Water system operated and tested; flow meets unit design requirement				
Flow switch installed, wired, and calibrated				
Condenser Water	Yes	No	N/A	Initials
Cooling tower flushed, filled, vented; Water treatment in place				
Pumps installed and operational (rotation checked, strainers installed and cleaned)				
Controls (3-way valves, bypass valves, etc.) operable per IM/IOM				
Water system operated and flow balance to meet unit design requirement				
Flow switch installed, wired, and calibrated				
Electrical	Yes	No	N/A	Initials
115 volt service completed, but not connected to control panel (remote mounted starters)				
Line Power Leads connected to starter; load leads (b) run from starter to compressor, ready for connection by Service (Do not connect load leads to starter or compressor terminals). (See Notes 1 & 4)				
All interlock wiring complete and compliant with Daikin Applied specifications				
Starter complies with Daikin Applied specifications				
*Oil cooler solenoid wired to control panel as shown on wiring diagram (See Notes)				
Pump starter and interlocks wired				
Cooling tower fans and controls wired				
Wiring complies with National Electrical Code and local codes (See Note 4)				
Condenser pump starting relay (CP1,2) installed and wired (See Note 3)				
Miscellaneous	Yes	No	N/A	Initials
*Oil cooled water piping complete. (Units with water-cooled oil coolers only)				
Relief valve piping complete (per local codes)				
Thermometers, wells, gauges, control, etc., installed				
Minimum system load of 80% capacity available for testing/adjusting controls				
SiteLine™ cloud-connected controls included and needs to be commissioned				
Document Attached: Technical Breakdown from Daikin Tools				
Document Attached: Final Order Acknowledgement				
Notes: The most common problems delaying start-up and affecting unit reliability are:				
1. Field installed compressor motor power supply leads too small. Questions: Contact the local Daikin Applied sales representative. State size, number and type of conductors and conduits installed:				
a. From Power supply to starter _____				
b. From starter to chiller unit (remote mounted) _____				
2. Centrifugal chillers with water cooled oil coolers must have a 115 volt normally closed water solenoid valve installed in the oil cooler water supply line. Daikin Applied recommends ASCO Type 8210B27 solenoid valve or approved equal and 40-mesh strainer. Daikin Applied does not supply these components.				
3. A 115-volt field-supplied relay (CP1,2) must be used to start/stop condenser water pump on most applications. Cold condenser water must not flow through condenser during compressor off cycle. Provisions have been made in control center for connecting CP relay, but must not have a rating in excess of 100 VA.				
4. Refer to NEC Article 430-22 (a) *Does Not Apply to Magnetic Bearing Chillers (WMC/WME)				

Limited Product Warranty

DAIKIN APPLIED AMERICAS INC. LIMITED PRODUCT WARRANTY (United States and Canada)

WARRANTY

Daikin Applied Americas Inc. dba Daikin Applied ("Company") warrants to contractor, purchaser and any owner of the product (collectively "Owner") that, subject to the exclusions set forth below Company, at its option, will repair or replace defective parts in the event any product manufactured by Company, including products sold under the brand name Daikin and used in the United States or Canada, proves defective in material or workmanship within twelve (12) months from initial startup or eighteen (18) months from the date shipped by Company, whichever occurs first. Authorized replacement parts are warranted for the remainder of the original warranty. All shipments of such parts will be made FOB factory, freight prepaid and allowed. Company reserves the right to select carrier and method of shipment. In addition, Company provides labor to repair or replace warranty parts during Company normal working hours on products with rotary screw compressors or centrifugal compressors. Warranty labor is not provided for any other products.

Company must receive the Registration and Startup Forms for products containing motor compressors and/or furnaces within ten (10) days of original product startup, or the ship date and the startup date will be deemed the same for determining the commencement of the warranty period and this warranty shall expire twelve (12) months from that date. For additional consideration, Company will provide an extended warranty(ies) on certain products or components thereof. The terms of the extended warranty(ies) are shown on a separate extended warranty statement.

No person (including any agent, sales representative, dealer or distributor) has the authority to expand the Company's obligation beyond the terms of this express warranty or to state that the performance of the product is other than that published by Company.

EXCLUSIONS

1. If free warranty labor is available as set forth above, such free labor does not include diagnostic visits, inspections, travel time and related expenses, or unusual access time or costs required by product location.
2. Refrigerants, fluids, oils and expendable items such as filters are not covered by this warranty.
3. This warranty shall not apply to products or parts : (a) that have been opened, disassembled, repaired, or altered, in each case by anyone other than Company or its authorized service representative; (b) that have been subjected to misuse, abuse, negligence, accidents, damage, or abnormal use or service; (c) that have not been properly maintained; (d) that have been operated or installed, or have had startup performed, in each case in a manner contrary to Company's printed instructions; (e) that have been exposed, directly or indirectly, to a corrosive atmosphere or material such as, but not limited to, chlorine, fluorine, fertilizers, waste water, urine, rust, salt, sulfur, ozone, or other chemicals, contaminants, minerals, or corrosive agents; (f) that were manufactured or furnished by others and/or are not an integral part of a product manufactured by Company; or (g) for which Company has not been paid in full.
4. This warranty shall not apply to products with rotary screw compressors or centrifugal compressors if such products have not been started, or if such startup has not been performed, by a Daikin Applied or Company authorized service representative.

SOLE REMEDY AND LIMITATION OF LIABILITY

THIS WARRANTY CONSTITUTES THE SOLE WARRANTY MADE BY COMPANY. COMPANY'S LIABILITY TO OWNER AND OWNER'S SOLE REMEDY UNDER THIS WARRANTY SHALL NOT EXCEED THE LESSER OF: (i) THE COST OF REPAIRING OR REPLACING DEFECTIVE PRODUCTS; AND (ii) THE ORIGINAL PURCHASE PRICE ACTUALLY PAID FOR THE PRODUCTS. COMPANY MAKES NO REPRESENTATION OR WARRANTY, EXPRESS OR IMPLIED, REGARDING PREVENTION OF MOLD/MOULD, FUNGUS, BACTERIA, MICROBIAL GROWTH, OR ANY OTHER CONTAMINATES. THIS WARRANTY IS GIVEN IN LIEU OF ALL OTHER WARRANTIES, INCLUDING, WITHOUT LIMITATION, THE IMPLIED WARRANTIES OF MERCHANTABILITY, FITNESS FOR A PARTICULAR PURPOSE, AND NON-INFRINGEMENT, WHICH ARE HEREBY DISCLAIMED. IN NO EVENT AND UNDER NO CIRCUMSTANCE SHALL COMPANY BE LIABLE TO OWNER OR ANY THIRD PARTY FOR INCIDENTAL, INDIRECT, SPECIAL, CONTINGENT, CONSEQUENTIAL, DELAY OR LIQUIDATED DAMAGES FOR ANY REASON, ARISING FROM ANY CAUSE WHATSOEVER, WHETHER THE THEORY FOR RECOVERY IS BASED IN LAW OR IN EQUITY, OR IS UNDER A THEORY OF BREACH CONTRACT OR WARRANTY, NEGLIGENCE, STRICT LIABILITY, OR OTHERWISE. THE TERM "CONSEQUENTIAL DAMAGE" INCLUDES, WITHOUT LIMITATION, THOSE DAMAGES ARISING FROM BUSINESS INTERRUPTION OR ECONOMIC LOSS, SUCH AS LOSS OF ANTICIPATED PROFITS, REVENUE, PRODUCTION, USE, REPUTATION, DATA OR CROPS.

ASSISTANCE

To obtain assistance or information regarding this warranty, please contact your local sales representative or a Daikin Applied office.

Form No. 933-430285Y-01-A (11/2023)

COMPLETE HVAC SYSTEM SOLUTIONS

SELF-CONTAINED | ROOFTOPS | COILS | CONDENSING UNITS
AIR HANDLERS | WATER-COOLED CHILLERS | AIR-COOLED CHILLERS
MODULAR CENTRAL PLANTS | SITELINE BUILDING CONTROLS
UNIT HEATERS | FAN COILS | AIR PURIFIERS | WATER SOURCE HEAT PUMPS
VARIABLE AIR VOLUME UNITS | UNIT VENTILATORS



13600 INDUSTRIAL PARK BLVD. | MINNEAPOLIS, MN 55441
1-800-432-1342 | 763-553-5330

LEARN MORE AT
DAIKINAPPLIED.COM

PART NUMBER: IOM1266-4

© 2024 DAIKIN APPLIED | (800) 432.1342 | WWW.DAIKINAPPLIED.COM