



# Installation and Maintenance Manual

# IM 672-23

Group: Applied Air Systems

Part Number: IM672-23

Date: June 2023

## Vision® Air Handler

Models CAC/CAH 003—090 C



# Table of Contents

<b>Introduction</b> .....	<b>3</b>	<b>Fixed Plate Exchanger</b> .....	<b>47</b>
<b>Mechanical Installation</b> .....	<b>5</b>	Frost Protection .....	47
Service Clearances .....	5	Economizer Mode .....	47
Rigging .....	6	Mixed-Air System .....	47
Unit Leveling .....	8	CORE® Enthalpy Fixed Plate Exchanger .....	47
Assembling Sections .....	8	Sensible Fixed Plate Heat Exchanger .....	48
Panels, Frame Channels, and Doors .....	13	<b>Maintenance</b> .....	<b>49</b>
HEPA Holding Frame, Filter, and Prefilter Installation	17	Periodic Maintenance .....	49
Multizone Assembly .....	21	Filters .....	55
Duct Connections .....	22	Coils .....	56
Piping and Coils .....	24	<b>Replacement Parts</b> .....	<b>59</b>
Internal Isolation Assembly Adjustment .....	28	<b>Service and Warranty Procedure</b> .....	<b>60</b>
HCAI Seismic Anchoring/Mounting .....	31	Warranty .....	60
<b>Electrical Installation</b> .....	<b>32</b>	Warranty Return Material Procedure .....	60
Wiring .....	32	<b>Check, Test, and Start Procedure Form</b> .....	<b>61</b>
<b>Operation</b> .....	<b>33</b>	<b>Quality Assurance Survey Report</b> .....	<b>67</b>
Startup Checks .....	33		
VFD Setup .....	34		
Fan Startup .....	34		
Fan Wheel Alignment .....	34		
<b>Daikin Applied Fan Array</b> .....	<b>37</b>		
<b>Daikin Applied EC Fan Array</b> .....	<b>40</b>		
Fan Operating Limits .....	46		
Fan Vibration Levels .....	46		

©2023 Daikin Applied, Minneapolis, MN. All rights reserved throughout the world. This document contains the most current product information as of this printing. Daikin Applied Americas Inc. has the right to change the information, design, and construction of the product represented within the document without prior notice. For the most up-to-date product information, please go to [www.DaikinApplied.com](http://www.DaikinApplied.com).

™® Vision, MicroTech, SiteLine, and Daikin Applied are trademarks or registered trademarks of Daikin Applied Americas Inc. The following are trademarks or registered trademarks of their respective companies: BACnet from American Society of Heating, Refrigerating and Air-Conditioning Engineers, Inc.; Echelon, LonWorks, LonMark, and LonTalk from Echelon Corporation; Modbus from Schneider Electric; and Windows from Microsoft Corporation.

# Introduction

## General Information

**⚠ CAUTION**

Sharp edges and coil surfaces are a potential injury hazard. Avoid contact with them.

Vision® indoor air handlers are not designed to be weather resistant. Do not install them outdoors.

The system design and installation must follow accepted industry practice as described in the ASHRAE Handbook, the National Electric Code, and other applicable standards. This equipment must be installed in accordance with regulations of authorities having jurisdiction and all applicable codes.

Installation and maintenance must be performed by qualified personnel familiar with applicable codes and regulations and experienced with this type of equipment. Sheet metal parts, self-tapping screws, clips, and such items inherently have sharp edges; the installer should exercise caution.

## Receiving and Handling

### Inspection

- Carefully check items against the bills of lading to verify all crates and cartons have been received. Carefully inspect all units for shipping damage. Report damage immediately to the carrier and file a claim.

### Packaging

- All shipping wrap material, including stretch and shrink wrap, must be removed upon unit arrival. This wrapping is for transit protection only. Units are not to be stored with wrapping material left on, as white rust will develop if any moisture is present.

## Nomenclature

CAH 003 G D A C

<p><b>Model</b> _____</p> <p>CAH = Custom modular air handler CAC = Custom modular component</p> <p><b>Nominal unit size</b> _____ (cataloged size—nominal square foot of coil) 003, 004, 006, 008, 010, 012, 014, 017, 021, 025, 030, 035, 040, 050, 065, 080, 085, 090</p> <p><b>Vintage of Daikin Applied air handling unit</b> _____</p> <p><b>Unit type/coil position</b> _____</p> <p>B = Blow-through cooling coil location D = Draw-through cooling coil location H = Heating only V = Vent only M = Multizone</p>	<p><b>Unit cross section</b></p> <p>C = Standard unit cross section M = Custom size cross section</p> <p><b>Motor location</b></p> <p>A = Motor along side of fan housing C = Motor downstream of ECM fan D = Motor downstream of belt-drive plenum fan G = Motor downstream of direct-drive plenum fan H = Motor downstream of direct-drive plenum fan in fan array T = Motor behind twin fan housing</p>
--	--

- Field-installed components will ship on separate skid(s).
- Hardware (screws, bolts, etc.) for assembling sections are supplied in a bag attached to each section. All necessary gasketing is applied in the factory for section-to-section mounting. NOTE: A special #30 Torx bit is required for assembly.

## Identification

- Every shipping section includes a nameplate identifying the customer tagging information, unit serial number, unit order number, and the shipping section position for installation.

## Handling

- Vision air handler units are constructed of painted or galvanized steel and are inspected thoroughly before leaving the factory. Take care during installation to prevent damage to units. Do not stand or walk on top of units.
- Air handler bases are designed with the necessary number of lifting points for safe installation. All lifting locations must be used. See Rigging.
- Take special care when handling blower sections. All fans are dynamically balanced before leaving the factory. Rough handling can cause misalignment or a damaged bearings or shaft. Carefully inspect fans and shaft before unit installation to verify this has not happened.
- Handle the zone damper of the multi-zone units with special care. Zone dampers are set and inspected before leaving the factory but should be checked on arrival to the job to verify the bell arm and connecting rod set screws did not become loose in shipment.

## Unit Storage

- Vision air handlers are not to be stored outdoors. Any damage to the unit resulting from improper storage will not be covered by Daikin Applied.
- Ensure no moisture, debris, or minerals are on the unit prior to storage, as these can cause permanent damage to the cabinet and components.
- Store units indoors in a clean, dry environment on a level surface. Ensure units are on a dry surface or raised off the ground to protect components from any standing water; ensure adequate support is used to prevent the unit or section base from sagging, if raised.
- All openings, including dampers and bottom openings, must be covered to protect from dust and animals. If tarping the unit, do not use plastic tarps, as condensation can form on the air handler resulting in corrosion or stains. Use only canvas tarps to ensure the inside of the unit remains clean, dry, and ventilated. Do not allow coverings to trap moisture on surfaces.
- All shipping wrap material, including stretch and shrink wrap, must be removed upon unit arrival. Units are not to be stored with wrapping material left on, as white rust will develop if any moisture is present.
- A field-supplied desiccant bag may be hung in the interior of the unit to minimize corrosion in humid storage environments.
- Do not stack sections or store anything on top of units.
- Isolate unit from shock and vibration.
- Do not clean galvanized steel surfaces with oil dissolving chemicals. This may remove the protective coating and accelerate corrosion.
- Pack fan and motor bearings (unless motor bearings are sealed) with compatible grease while the fan shaft is stationary. After grease has been installed, rotate shaft a minimum of 10 rotations.
- Once a month, rotate shaft a minimum of 10 revolutions. Ensure the stopped position is different than the original position.
- Coat shafts with lubricant as needed to prevent corrosion.
- Inspect all doors and openings once a month to ensure they are closed and properly sealed.
- Loosen belt tension on belt-driven fans, if storing for more than two (2) months.

## Belt-Driven fans

- Reduce belt tension by at least 50% or remove the belts. Remove belts if they will be subjected to temperatures exceeding 85° F to avoid deterioration.
- Remove belt guard when adjusting belts
- Reduce belt tension prior to removing or installing belts.
- Removing or installing tensioned belts may cause personal injury and damage to the sheaves, belts, bearings or shafts.
- Adjustable sheaves should be opened as wide as possible and the adjustment threads lubricated so they do not corrode. Be careful not to put lubricant on the belt running surface

### *Prior to start up*

- Set screws on bearings, fan wheels, and sheaves need to be checked for proper torque. Also check bolt torque for any taper lock hubs either on the wheel or sheaves.
- Check sheaves for corrosion. Significant corrosion can cause belt or sheave failure.
- Purge old grease from fan bearings while rotating the shaft to distribute the new grease evenly and prevent bearing seal failure.
- Correctly align and tension belts. See [on page 54](#).

## Gas Furnace

For installation and maintenance information related to gas heat, refer to [IM 1300](#).

# Mechanical Installation

## Service Clearances

In addition to providing adequate space around the unit for piping coils and drains, access to at least one side of the unit is always required to allow for regular service and routine maintenance, which includes filter replacement, drain pan inspection and cleaning, fan bearing lubrication, and belt adjustment. Provide sufficient space—at least equal to the length of the coil—on the side of the unit for shaft removal and coil removal. Space, at least equal to the length of the side coil, is required for coil removal. Space, at least equal to the fin height, is required for top coil removal. See Figure 1 for servicing space requirements.

For routine maintenance purposes, access normally is obtained through the access doors or by removing panels. Fan and filter sections are always provided with a service door on one side of the unit. If requested, doors can be provided on both sides of the unit. Optional service doors are available for most section types and are provided based on customer request.

If component replacement is required, the top panel also can be removed. If necessary, the unit can be disassembled. Maintain at least 54" of clearance in front of electrical power devices (starters, VFDs, disconnect switches and combination devices). Electrical power devices that are mounted on the side of the unit typically are up to 12" deep (Figure 2). Fan sections with multiple fans have motor control boxes up to 16" deep when supplied with VFDs.

Figure 1: Servicing Space Requirements

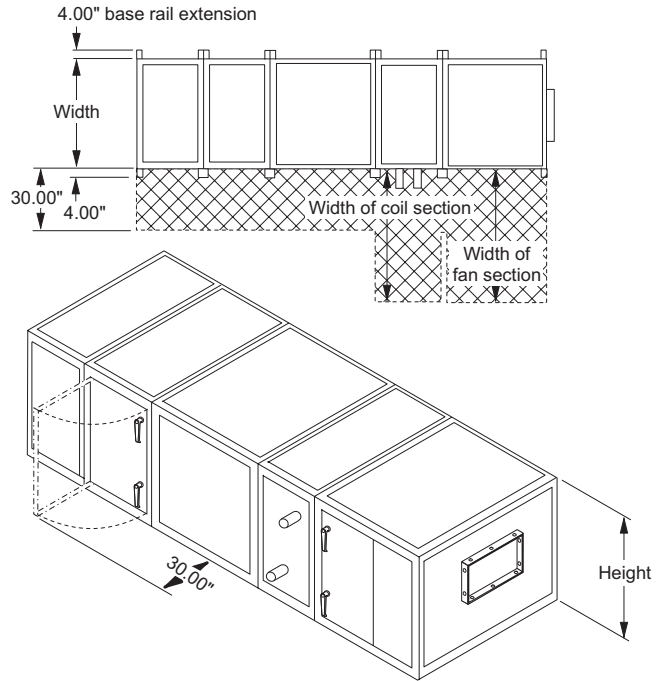
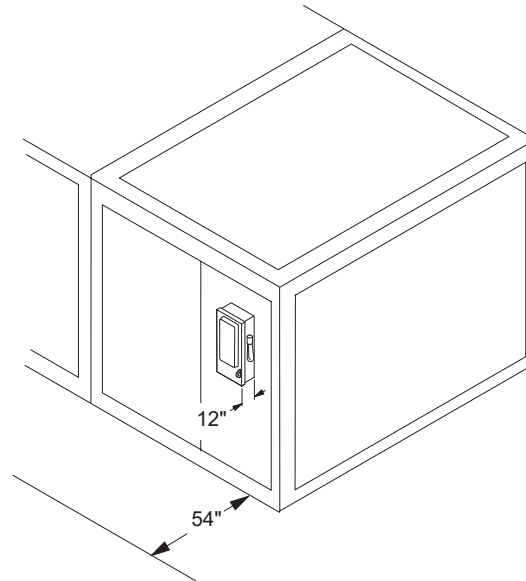


Figure 2: Service Clearance for Electrical Power Devices



# Rigging

**WARNING**  
 A licensed and/or professional rigger is responsible for developing a safe lift plan to meet local/national/international codes.

**WARNING**  
 Use all lifting points. Improper lifting can cause severe personal injury, death or property damage.

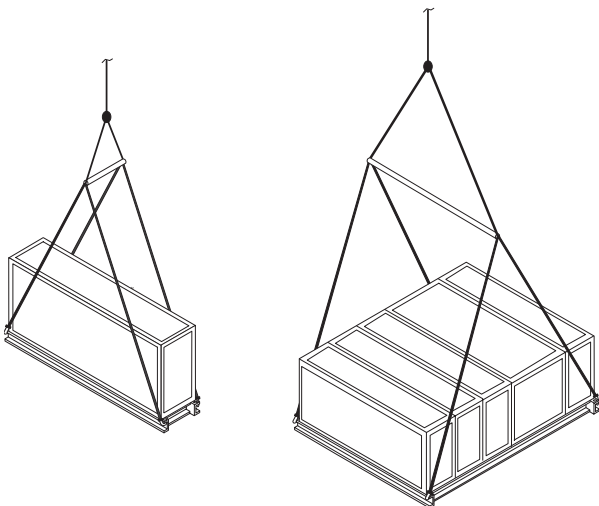
**CAUTION**  
 Lifting points may not be symmetrical to the center of gravity of the unit. Ballast or unequal cable lengths maybe required.

Vision air handlers ship as separate sections, completely assembled, or in modules of assembled sections. The unit must be rigged as it ships from the factory. Do not assemble sections or modules at the site before rigging as final assembly should be completed at point of installation. When a unit is provided with a factory-installed base rail, it can be lifted using the 2" diameter lifting holes located in the corners of each shipping section (Figure 3). If a unit does not have a base rail, rig it using straps or a sling. Fasten the strapping under the cabinet (Figure 4).

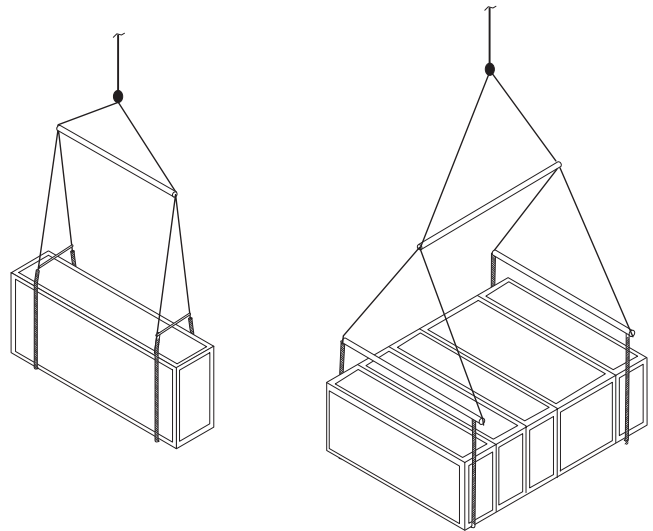
To prevent damage to the unit cabinetry, use spreader bars. Position spreader bars to prevent cables from rubbing the frame or panels. Before hoisting into position, test lift for stability and balance. Avoid twisting or uneven lifting of the unit.

A fan array or coil section might have a tall, thin aspect ratio. The center of balance on these sections can be high and make the section prone to tipping during the lift. Care should be taken when lifting units with a tall, thin aspect ratio.

**Figure 3: Units on Base Rails**

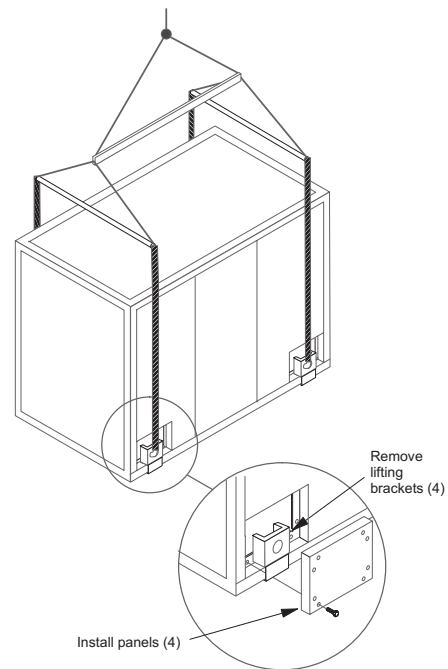


**Figure 4: Units without Base Rails**



Housed fan sections greater than 107" wide or motors behind housed fans that are stacked on another section that are not Class II plenum fans are constructed with internal fan support frames that have integral lifting brackets (Figure 5). After the fan section is placed in position, remove and discard the lifting brackets. Install the small panels provided to complete the unit cabinet areas where the lifting brackets were located.

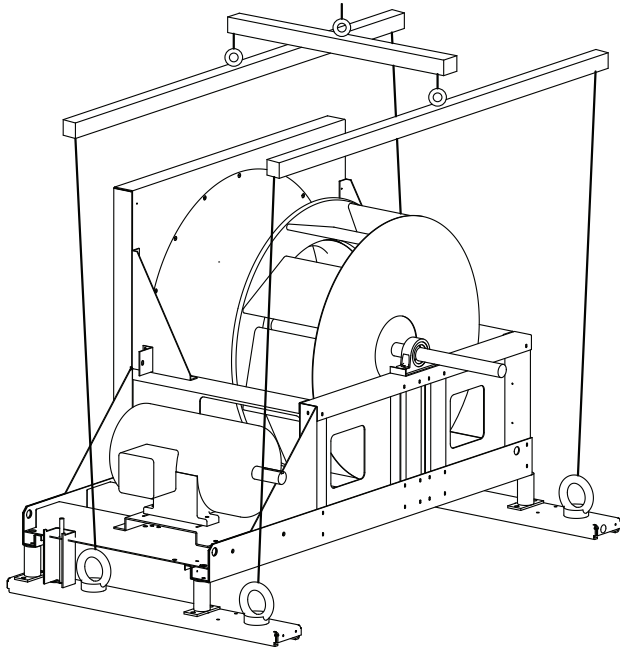
**Figure 5: Large Fan Sections Stacked on Top of a Lower Section**



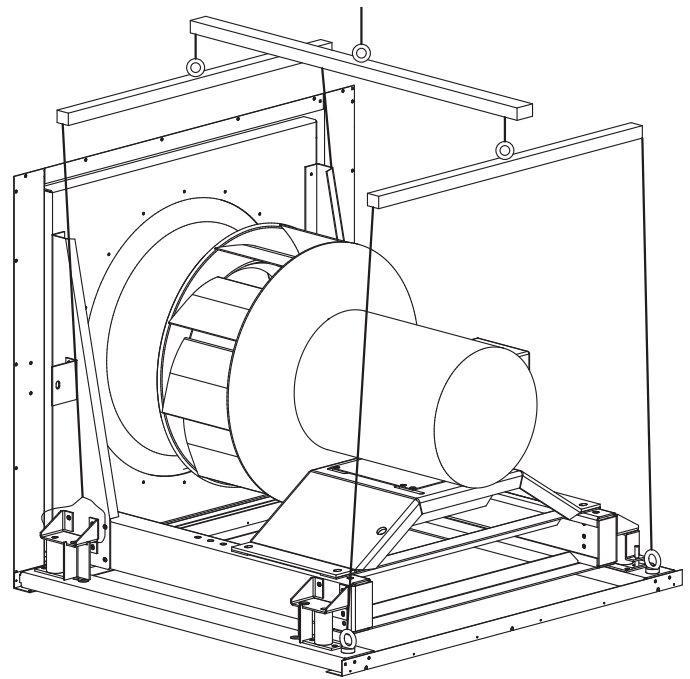
Class II plenum fans that are stacked on another section may be lifted using the methods shown in the following figures. The shipping brackets must remain in place and be tight in order to lift using this method. **Figure 6** shows a belt-drive fan with field supplied eye bolts that are screwed into factory installed hex AVK fasteners in the main channels supporting the fan. **Figure 7** shows a direct-drive fan with field supplied eye bolts on the motor end and straps around the spring bracket on the inlet end. When factory installed hex AVK fasteners are installed, they should be used for lifting. When they are not installed, it is acceptable to lift from the shipping brackets on the fan. **Figure 8** shows dual fans being lifted in a similar manner as the single direct-drive fan. An eight point lift must be used for dual fans to make sure both fans are supported properly and the cabinet structure does not become overloaded along the center.

If the fan section is connected to another section such as a plenum or access section, then **DO NOT** attempt to lift both sections using just the fan section. The other section(s) must be supported separately using straps.

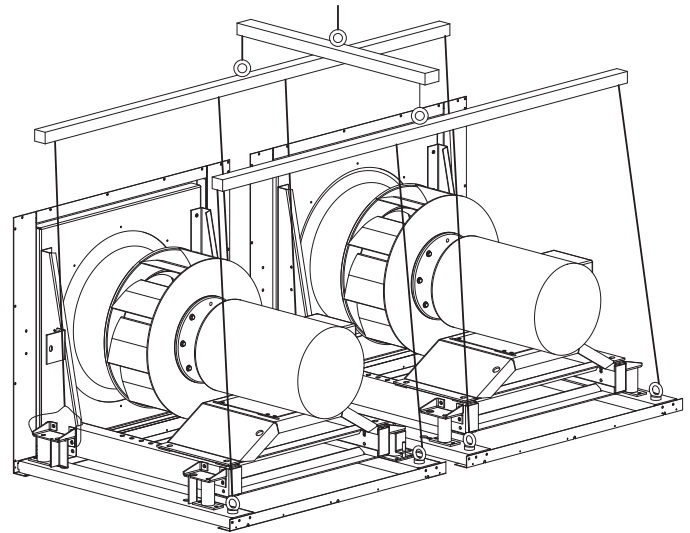
**Figure 6: Belt-Drive Class II Plenum Fan Stacked Unit**



**Figure 7: Direct-Drive Class II Plenum Fan Stacked Unit**



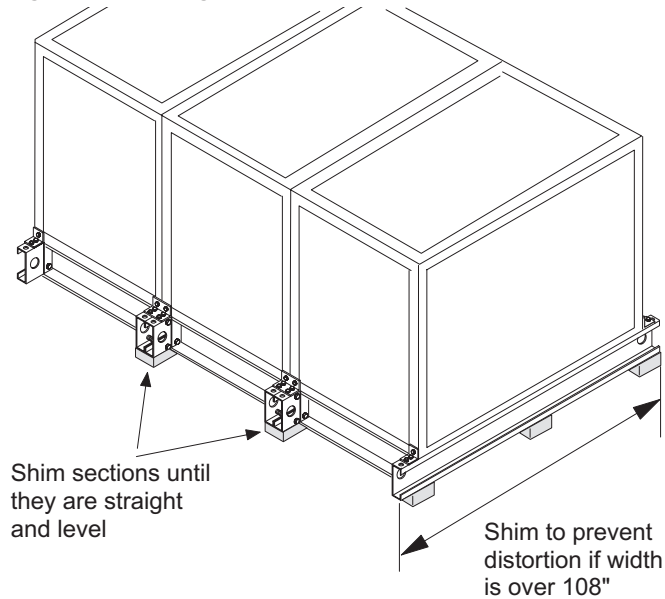
**Figure 8: Direct-Drive Class II Dual Plenum Fan Stacked Unit**



## Unit Leveling

Place the equipment on a flat and level surface. Where the surface irregularities could cause the equipment to distort, use a shim so the base of the unit is a straight line. Uneven or distorted sections cause misfit or binding of the doors and panels and improper draining of drain pans. Units that are over 108" wide must rest on a flat surface for the entire width of the base rails or must be shimmed at one or more points along the length of the rails to prevent distortion or sagging of the support rails (Figure 9).

**Figure 9: Leveling the Unit**



## Horizontal Airflow Section Mounting

1. Rig the unit into position and lineup shipping sections in the direction of air flow. Pull sections together to fasten. Use a furniture clamp or straps and a ratchet to help pull the sections together securely at the top and bottom (Figure 11).
2. If the unit has a factory-installed base rail, first fasten base rails together using the 3/8"-16 x 5" bolts located in the splice kit provided with the unit.
  - a. To fasten two shipping sections together, four bolts are needed (two on each side of the unit). The bolts are run from one base rail into the other and fastened with a nut. Complete each section bottom and top before attaching additional sections.
3. If no base rail is provided, fasten the unit in the same manner on the bottom and top frame channels.
4. Once the sections are positioned together, remove the fastener in each of the channel corners (on the mating edges in the channel piece).
5. Place a flat section joining plate (found in the splice kit) over the two coned holes in the channels, so that the plate spans the two sections.
6. Replace the fasteners in their original position, through the joining plate.
7. For certain high pressure, low leakage units, use the provided section joining plates to fasten sections together. Space them as shown in Figure 12. Using the provided 1/4"-14 x 1" self tapping screws, drill screw the joining plates into the frame channel on each section, keeping unit sections tight together. Follow instruction drawing included in the assembly kit.

## Assembling Sections

### External Section-to-Section Mounting

Vision air handling units can ship fully assembled or as separate shipping sections. Rig units that require field assembly of shipping sections into position first. Shipping sections are provided with a connection splice joint attached to the cabinet which seals against the gasket of the frame channel on the adjoining shipping section. The splice joint provides an air seal between two sections once they are assembled together. Some unit configurations require multiple splice joints on the same face or on opposing faces of a single section. Confirm correct placement and orientation of unit sections and splice joints based on included unit drawings. Align all splice joints to seat into the mating gasket to provide an air seal. If the splice joint was bent during shipping or rigging, restore it to its original position. (Figure 19 on page 11). Note: Some sections are shipped with shipping braces. These need to be removed before connecting the shipping sections. (Figure 10)

**Figure 10: Shipping Braces**





Figure 11: Horizontal Joining Sections

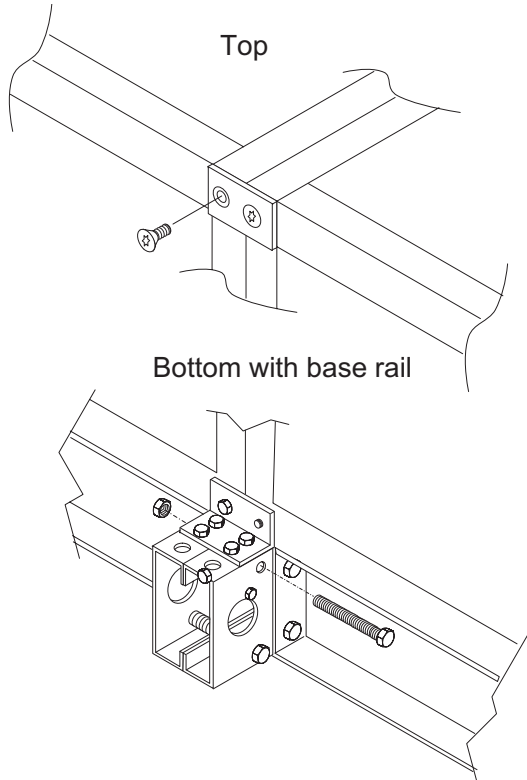
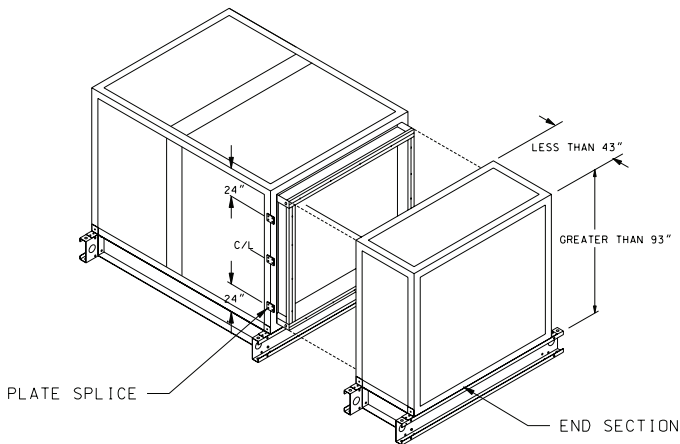


Figure 12: Frame Channel Stiffener Plates (High Pressure, Low Leakage Units Only)



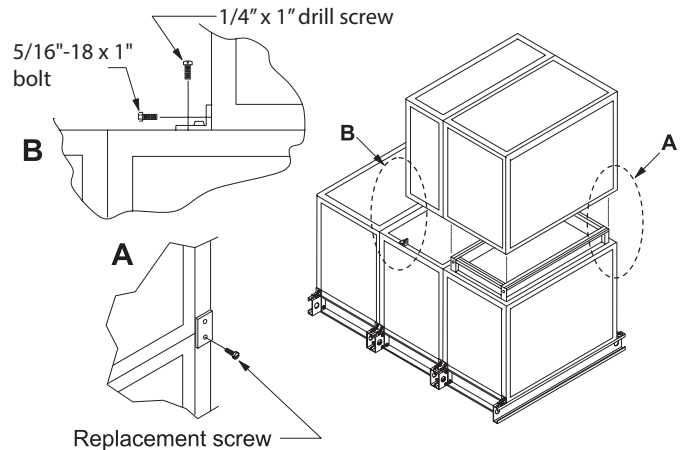
## Vertical Inverted Airflow Section Mounting

For vertical or inverted arrangements, before lifting any top mounting sections into place, rig into place and fasten together the bottom tier of sections. Once bottom level sections are in place and secured, lift stacked components and fasten using the following procedure:

**NOTE:** See [Face and Bypass Section Mounting on page 14](#) for the exception to this procedure.

1. The vertical/inverted section has a splice joint extending out the top of the bottom joining section. Lower the section that is to be positioned over the opening over the splice joint to seal the connection between the two sections.
2. The two sections are fastened together at the four bottom corners of the mating edge. To fasten the corners located on the end of the unit (where bottom section and top section walls are flush with each other), remove the flat head fasteners in the corners of both sections.
3. Cover the coned holes with a flat joining plate and replace the flat head fasteners in the holes to secure the joining plate to both sections ([Figure 13](#)).
4. When one section is deeper than the other, secure the two sections using an L-shaped joining plate. To secure the L-shaped bracket, remove the flat head fastener from the corner, position the bracket over the hole, and replace the flathead fastener with a 5/16"-18 x 1" bolt. Once the bolt is in place, secure the bracket to the adjoining section with a 1/4" x 1" drill screw. Repeat the same procedure on both corners of the unit ([Figure 13](#)).

Figure 13: Vertical/Inverted Joining Sections

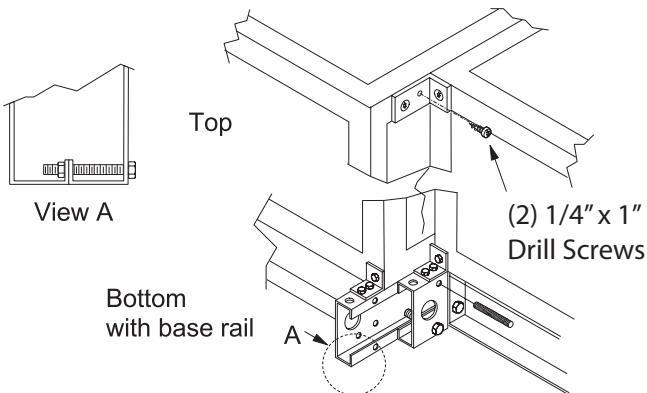


## Extended Coil Section Mounting

The extended coil section is 6" wider than all other sections of the same unit size. The extension is always located on the coil connection side of the unit. Because the extended coil section is wider than other sections, it always ships as a separate shipping section, and must be joined to other sections in the field. To join an extended coil section to other components, first follow the Horizontal Airflow Section Mounting, page 7 steps to secure the opposite connection side. To fasten the connection side, use the following procedure:

1. If the unit has a factory-installed base rail, the extended coil section base rail is also 6" wider than the adjoining base rail. Extended coil section base rails on the connection side are fastened together using the 3/8"-16 by 3" bolts located in splice kit provided with the unit (Figure 14).
2. If no base rail is provided, the section is fastened in the same manner on the bottom and top. Once the sections are positioned together, remove the fastener in the corner of the channel piece of the section mating to the extended coil section (Figure 14).
3. Place an L-shaped section joining plate (located in the splice kit) over the coned hole in the channel.
4. Replace the flat head fastener originally used in the corner with a 5/16"-18 1" bolt and fasten it through the L-shaped joining plate.
5. Position the L-shaped joining plate so it butts up against the extended coil section frame channel. To secure the plate to the extended coil section, run two 1/4" x 1" drill screws through the joining plate and into the frame channel.

Figure 14: Extended Coil Section Joining

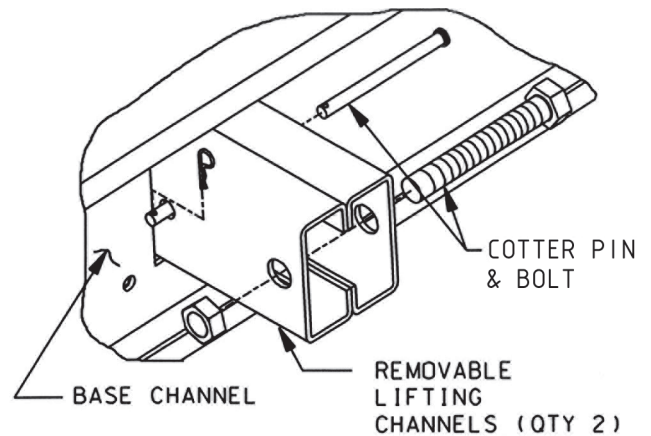


## Side-by-Side Heatwheel Section Joining

The side-by-side heatwheel will have two individual sections parallel in the direction of airflow to be attached to either side. Each section will attach to the heatwheel section and then to the other parallel section.

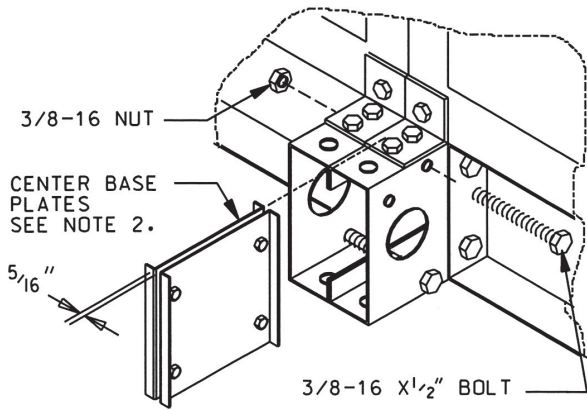
1. Rig the unit into position and line shipping sections up in direction of air flow. Sections must be pulled together to fasten using a furniture clamp or straps.
  - a. If the heatwheel section width is greater than 143", then rig the section into position using the two removable lifting channels. After section is properly placed, remove cotter pin and bolts from lifting channel and discard as seen in Figure 15

Figure 15: Cotter Pin and Bolt Detail



2. If included, remove center base plates that are attached to the base channels and save for Step 4.
3. If the unit has a factory installed base rail, fasten the base rails together using the 3/8"-16 x 5" bolts located in the splice kit provided with the unit.
  - a. To fasten two shipping sections together, two bolts are required on the one side. The bolts are run from one base rail into the other and fastened with a nut. Complete each section bottom and top before attaching additional sections.
4. Assemble the center base plates as show in Figure 16, leaving a 5/16" space between each plate to slide onto section base channels to center point of section width.
5. Once the sections are positioned together, remove the fastener in each of the channel corners (on the mating edges in the channel piece).
6. Place a flat section joining plate (found in the splice kit) over the two coned holes in the channels, so the plate spans the two sections.

Figure 16: Base Plate Detail



7. Replace the fasteners in their original position, through the joining plate.
8. Assemble the next section parallel to the assembled section by following Steps 1 – 7 above.
9. Using the 3/8"-16 × 1" bolts provided, fasten the two parallel sections' bases together as seen in Figure 17.
10. Using appropriate safety equipment if necessary, remove the fastener in each of the channel corners on the top between the two parallel sections and discard.
11. Use the 2 × 2 holed splice plate with 2 × 5/16"-18 × 1" screws and 2 × 1/4" drill screws. The 2 × 5/16"-18 × 1" screws will go into the frame channel holes and the 2 × 1/4" drill screws will go into the heatwheel frame channel as show in Figure 18.

Figure 17: Base Section Detail

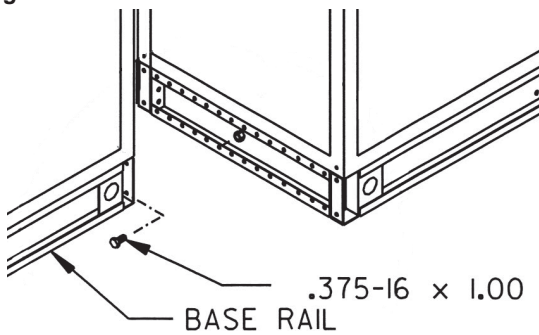
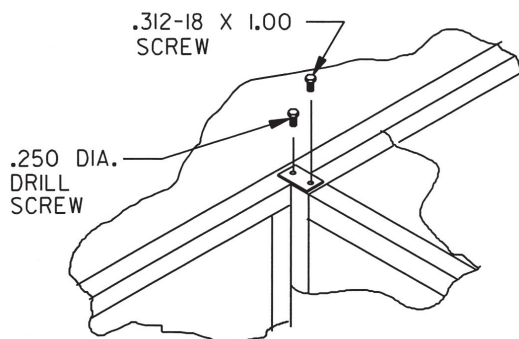


Figure 18: Frame Channel Detail



## Internal Section-to-Section Mounting

If desired, shipping sections can be fastened together internally. To fasten internally, run field-provided #10 sheet metal screws or drill screws (4" long maximum) through the interior frame channel of one unit into the splice joint of the neighboring section.

The section-to-section splice joint provided seals against the frame channel on the entering-air side of the adjoining section. Align the splice joint to seat into the mating gasket to provide an air seal. If the splice joint was bent during shipping or rigging, restore it to its original position (Figure 19).

For high pressure, low leakage units, ensure that the D-gasket is attached to the entering air side frame channel (Figure 20). If it has dislodged during shipping, restore to original location.

Figure 19: Splice Collar Alignment

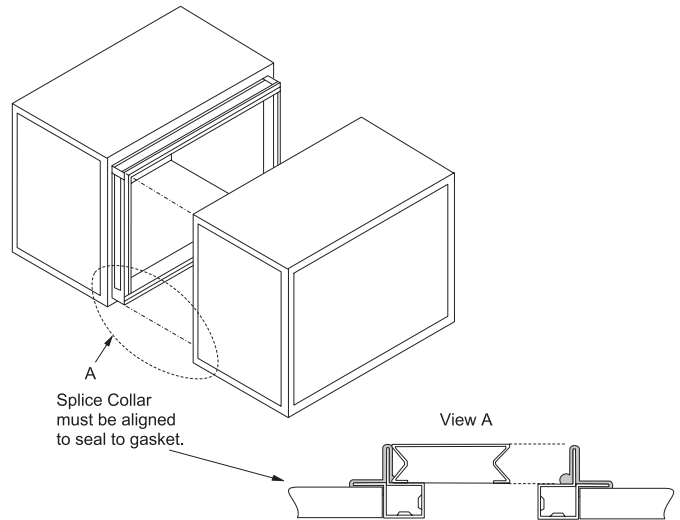
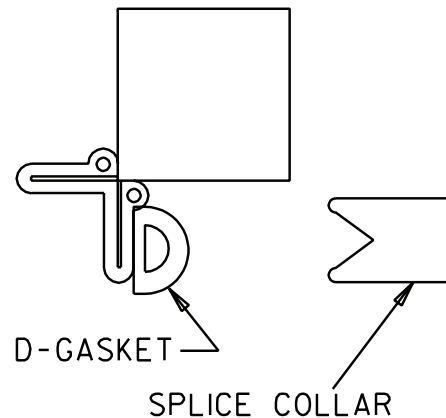


Figure 20: D-Gasket Placement Detail (High Pressure, Low Leakage Units only)



## Ceiling Hung

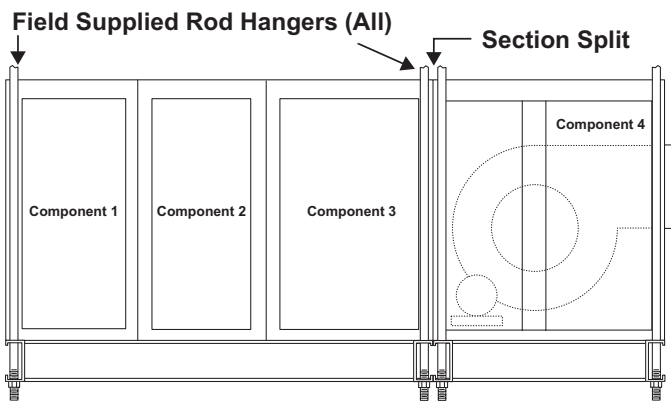
When a unit is ceiling hung, support it with a base rail, angle iron, or channel. The Vision air handler is not designed to be suspended from the top of the unit. Before hanging, rig and completely assemble the unit. See [Assembling Sections on page 8](#). Use vibration-resistant hardware to support ceiling hung units.

### Ceiling Hung Using Base Rail

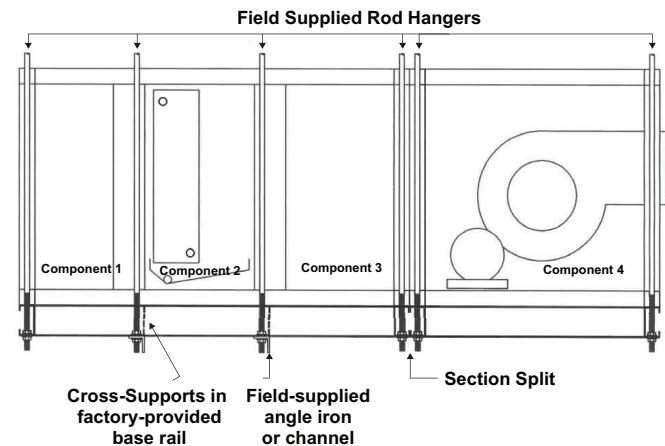
The optional base rail provided by the factory has 5/8" diameter holes in each corner to run hanger rods through. To properly support the unit and maintain unit integrity, support each shipping section with hanger rods in each corner ([Figure 21](#) and [Figure 22](#)) and support any base cross-support with field provided angle iron per SMACNA guidelines to adequately support the unit and keep it level.

Ceiling suspension using the unit base rails is limited to unit cabinet widths less than 108". Support units with cabinets 108" wide and greater with structural members designed to fully support the unit around the full unit perimeter and any base cross-supports.

**Figure 21: Ceiling Suspended with Base Rail and with Section Split(s) and No Cross Supports**



**Figure 22: Ceiling Suspended with Base Rail and Cross-Supports**



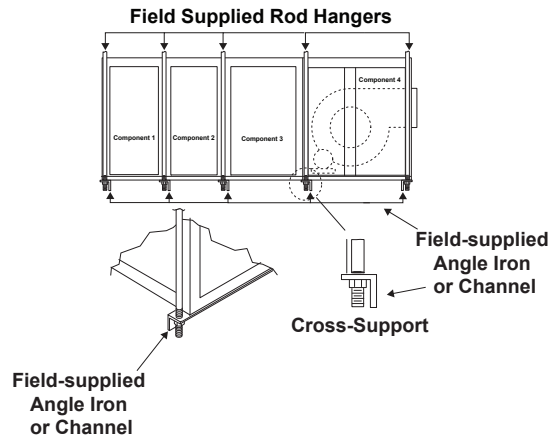
### Ceiling Hung Using Angle Iron or Channel (Units without Factory Supplied Base Rail)

Install field-provided angle iron or channels per SMACNA guidelines. When a unit is unitized (ships in one piece), support each component by adding field-supplied angle iron or channel along the width of the unit (perpendicular to airflow) on the upstream and downstream side of each component ([Figure 23](#)).

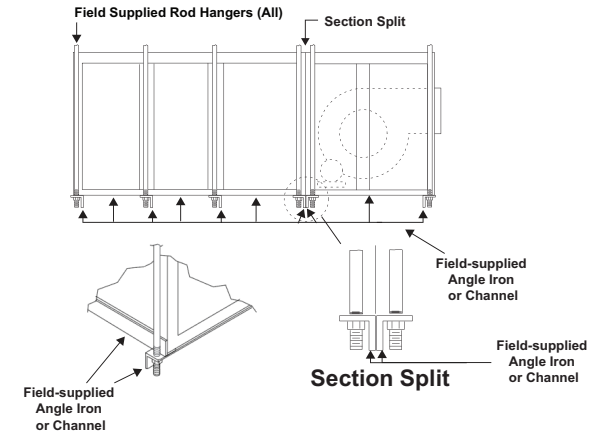
**NOTE:** The supporting angle iron must fully support the 2" frame channel at each section joint.

When a unit is modular (ships in multiple sections), channel support each component under the unit width and provide support under the full length of the unit base ([Figure 23](#)). Locate hanger rods so they do not interfere with access into the unit.

**Figure 23: Ceiling Suspended w/o Base Rail—Unitized Construction (No Shipping Splits)**

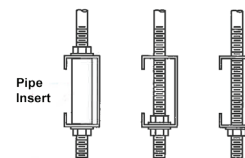


**Figure 24: Ceiling Suspended w/o Base Rail—Modular Construction (With Shipping Splits)**



**Figure 25: Mounting Hardware Configurations for All Ceiling Hung Units with Base Rail**

Pipe Support  
– to keep the base from deforming as the nuts are tightened



## Panels, Frame Channels, and Doors

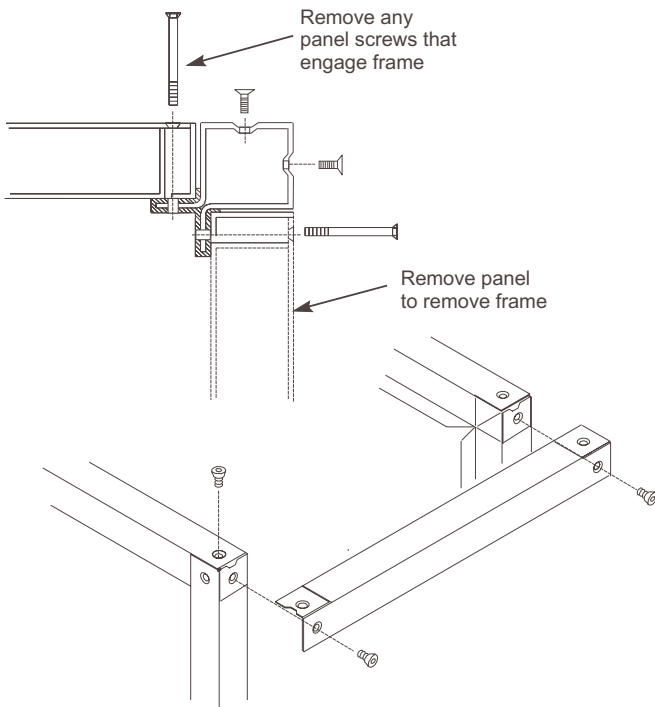
### Panel Removal

To remove a side or top panel, remove the flat head Torx 30 fasteners along the sides of the panel. Lift off the panel after removing all fasteners.

### Frame Channel Removal

Frame channels that run the length of the unit along the top can be removed to allow access to both the side and top of the unit. To remove the frame channel, first remove the side panel(s). Once the side panel is off, remove the flat head Torx 30 fasteners in the corner of the frame channels. Then pull the frame channel out the side. Remove any panel screws that are within one inch of the of the frame since they are engaged into the gasketed flange of the frame (Figure 26).

Figure 26: Removing Panel Screws



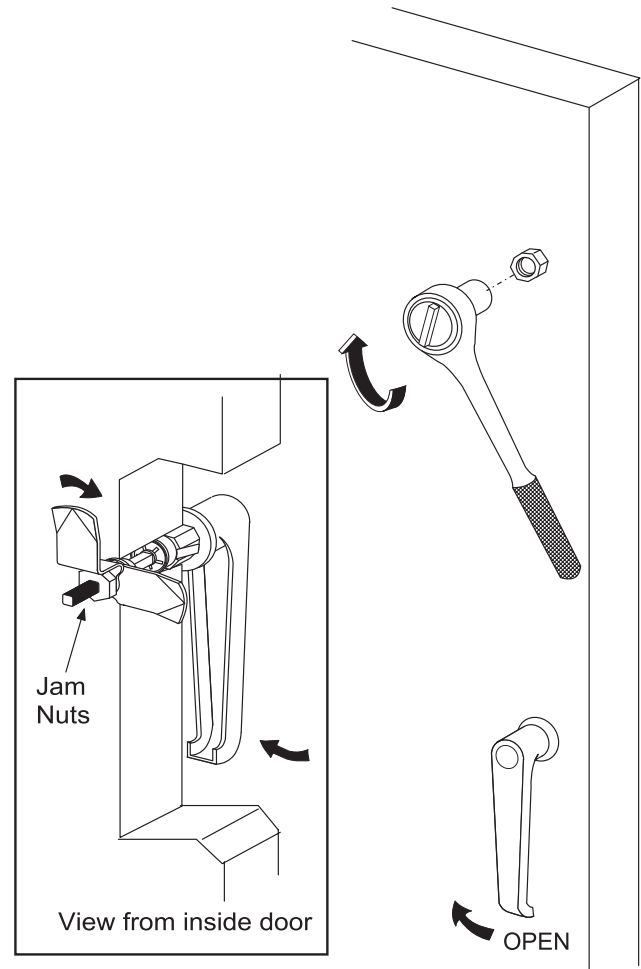
## Fan Section Doors

**CAUTION**

Sharp edges and coil surfaces are a potential injury hazard. Avoid contact with them.

**NOTE:** Opening fan section doors requires using a 17 mm socket wrench (Figure 27), which satisfies ANSI standards and other codes that require the “use of tools” to access compartments containing moving parts or electrical wiring.


Figure 27: Opening Fan Section Door



## Injected-Foam Insulated Panels

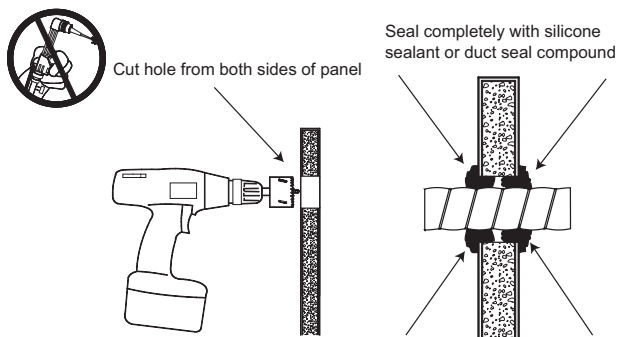
Vision air handlers are furnished with double-wall, injected-foam insulated panels. Foam panels are stronger, more rigid, and lighter than panels with fiberglass insulation. The insulation R-value is improved to 13. However, foam insulation can burn when exposed to flame or other ignition sources and release toxic fumes. Take care in cutting and sealing all field-cut openings in these panels.

### Panel Cutting Procedure

<b>⚠ WARNING</b>	
<p><b>Flame and smoke can cause equipment damage, severe personal injury, or death.</b></p> <p>Before operating unit, seal all piping and wiring holes on both inner and outer panels with an industrial grade silicone sealant or duct seal compound. <b>Do not use a cutting torch or expose panel to fire.</b> Panel damage can occur.</p>	

1. Determine the number and location of holes required for electrical conduit, piping, and control wiring as follows (also refer to [Figure 28](#)):
  - a. Check that adequate space is available inside the unit for conduit or pipe routing.
  - b. Do not locate holes in a panel that provides access to key maintenance components such as filters and fan assemblies.
  - c. Do not locate where the conduit or piping blocks airflow or obstructs hinged access doors.
2. Once a proper location is determined, drill a small pilot hole completely through the panel. Then use a sharp hole saw or a saber saw and cut from each side of the panel.
3. Seal the double-wall panel on each side with an industrial/ commercial grade silicone sealant or duct seal compound. It is extremely important to seal each panel hole or penetration securely so that it is airtight, watertight, and that there is no exposed foam insulation.

**Figure 28: Cutting/Sealing Injected-Foam Insulated panels**



Prop 65—Substances in fuel or from fuel combustion can cause personal injury or death, and are known to the State of California to cause cancer, birth defects or other reproductive harm.

## Field Mounting Junction Boxes and Other Components

For field mounting 4" × 4" or smaller junction boxes to the standard panel exterior, use a minimum quantity of four, 3/16" diameter pop rivets. **DO NOT** use self-tapping drill screws. They will not tighten nor secure properly and panel damage can occur.

If larger, heavier components require mounting on unit panels, use through-bolts with flat washers through both outer and inner panels. To maintain panel integrity, seal both ends with an industrial/commercial grade silicone sealant or duct seal compound.

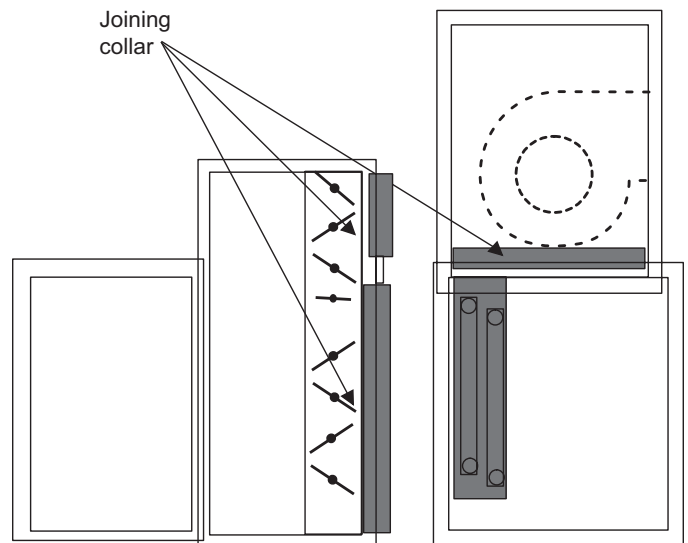
The unit frame channel is another excellent location for securing heavier components; self-tapping screws are not acceptable. Ensure that the location permits the full operation of all access doors and panels and does not interfere with other vital components.

## Face and Bypass Section Mounting

Internal face and bypass, and external face and bypass for sizes 003 to 035 are mounted together using the instructions for horizontal components and do not require additional instruction.

For all size units that bypass directly into a vertical fan section and for sizes 040 to 090 with external face and bypass, use the following instructions.

**Figure 29: Assembly of Fan Coil Sections**

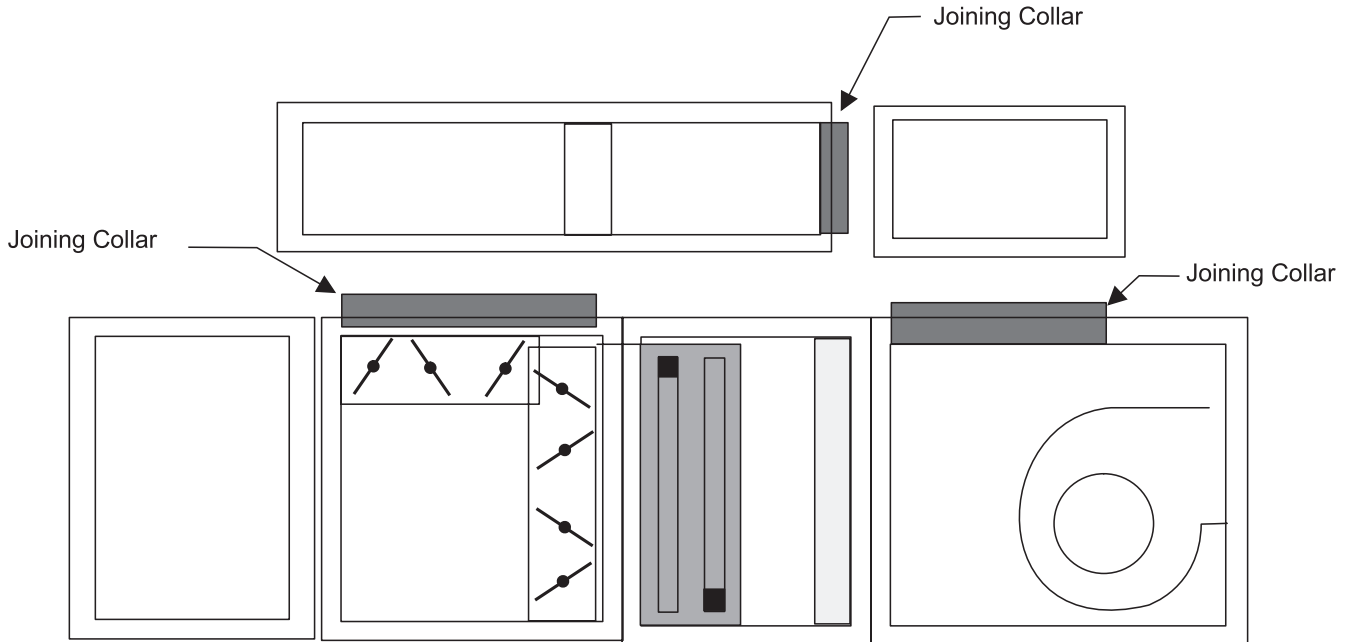


## Bypass Into a Vertical Fan Section

Vertical coil sections and the top mounted fan section always ship separately and must be mounted together at the job site. The vertical coil section and the bypass duct each has a joining collar mounted on the leaving air side of the section and duct, respectively (Figure 29). The mounting collar fits into the side (bypass) and bottom (vertical coil section) openings in the fan section. To correctly position the collars in the fan openings, assemble the fan and coil section first. Use the steps below for assembly.

1. Place the vertical coil section in position. If an access section is positioned downstream from the coil section and not already assembled to the coil section, secure the two sections together.
2. Lift the fan section on top of the vertical coil section, taking care to line up the joining collar in the bottom of the fan section.
3. For sizes 003 to 035, the bypass duct is integral to the unit construction and does not require attachment to the bypass section. For sizes 040 to 090, position and assemble the bypass duct to the bypass section before joining to the fan.
4. Once the fan is positioned on top of the vertical coil section and the bypass duct and bypass section are assembled, position the two assemblies and line up the joining collars with the openings in the fan and vertical coil section.
5. Once the sections are lined up and in position, secure the unit together by fastening joining plates to the unit.

**Figure 30: Assembly of Bypass Duct to Unit**



### External Face and Bypass Duct Assembly (Sizes 040 to 090)

When unit sizes 040 to 090 are ordered with external face and bypass, the bypass duct ships separately and must be attached to the unit in the field. The joining of the bypass duct to the unit must be done after the unit is assembled. Also, if the bypass duct is over 90" long, the duct does not ship in one piece and must be field assembled. The field assembly of the bypass duct to the unit requires the following steps (also refer to [Figure 30](#)).

Position the unit shipping sections together and assemble in the equipment room.

6. After the unit is assembled, lift the duct into position over the unit. Joining collars are shipped factory assembled to the unit and duct. There is a joining collar located in the top of the bypass opening and in the leaving air side of the bypass duct. These joining collars are used to provide air seals. Line up the duct with the top openings in the unit.
7. If the bypass duct is longer than 90", the duct ships in more than one piece and must be field assembled. Place the piece of duct that has the joining collar on the bottom on top of the unit first. Once it is in place, position the other piece of duct. Take care to fit the splice collar into the first piece of duct and then lower the other end into the bypass opening.
8. Once the duct is positioned correctly, fasten the duct pieces together with the joining plate provided. To do this, remove the fasteners in the corners of the duct assemblies, place the plate over the holes in the corners, and then replace the fasteners ([Figure 11 on page 9](#)).



## HEPA Holding Frame, Filter, and Prefilter Installation

These instructions are for installing AAF HEPA filters (11-1/2" depth) into AAF HEPA Holding Frames.

Please read the entire installation instructions before beginning the installation process.

Install filters into the HEPA Holding Frames only after the frames have been securely installed into existing ductwork or housing. Frames should be bolted or pop riveted together into the permanent structure through the pre-drilled holes around the outside perimeter of the frames. Frames should be sufficiently caulked and sealed after completing installation to prevent any air bypass or leakage.

### Required tools for filter installation:

- T-handle Hexkey, size 5/32"

### Framing Components Required:

- AAF HEPA Holding Frames
  - P/N 910111491 & 910111674
- Leg Extensions, 4 per frame (A)
  - P/N 910111494
- Latches, 4 per frame
  - P/N 910111493 (B) (without prefilters)
  - P/N 910123164 (C) (with prefilters)
- Prefilter Holding Frames (when prefilters are ordered)
  - P/N 910123166 & 910123168
- Prefilter Latches (when prefilters are ordered)
  - P/N 111048304 & 111048305

Figure 31: Leg Extensions and Latches without Prefilters

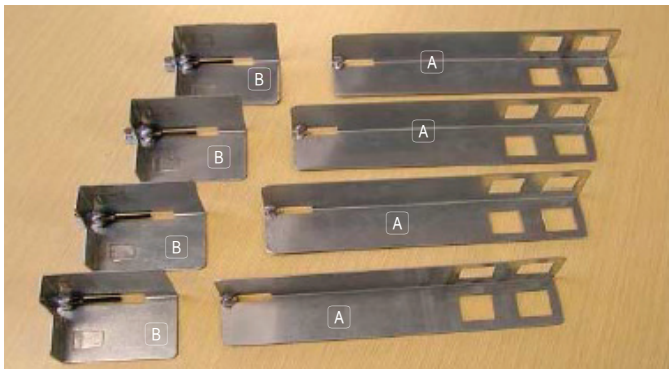


Figure 32: Leg Extensions and Latches with Prefilters



## AAF HEPA Filters without Prefilters

**STEP 1:** At the inside corner of each frame are 4 tabs, 2 per side. Place a leg extension over the 4 tabs as shown in Figure 33, then pull back on the leg extension locking it into place (Figure 34).

Repeat Step 1 with each of the 4 corners. The frame with leg extensions should look like Figure 35.

Figure 33: Place Leg Extension over the Frame Tabs

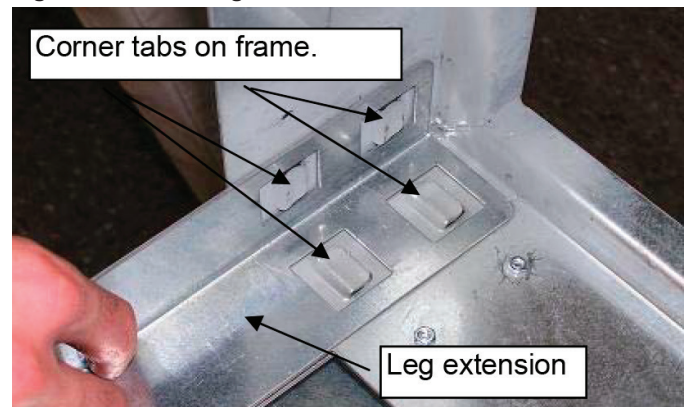
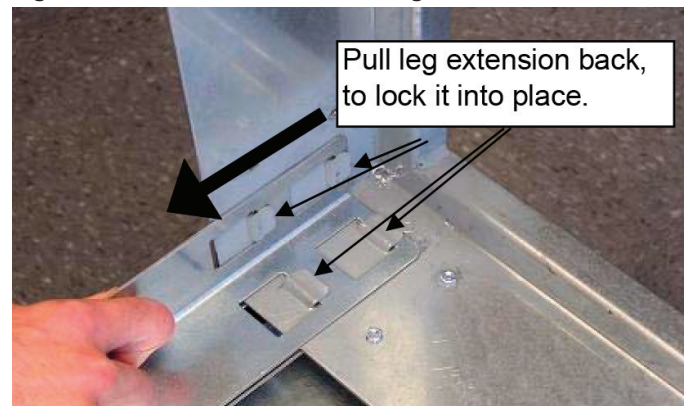


Figure 34: Pull Back to Lock the Leg Extension into Place



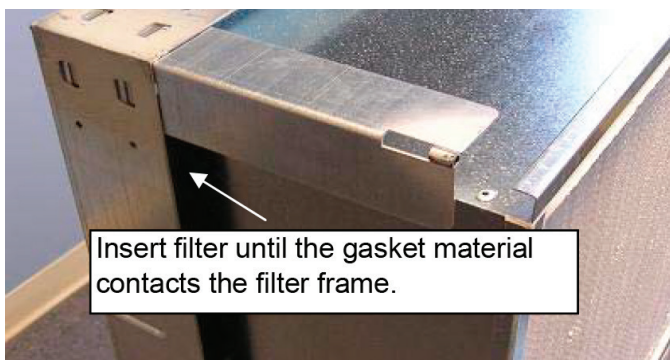
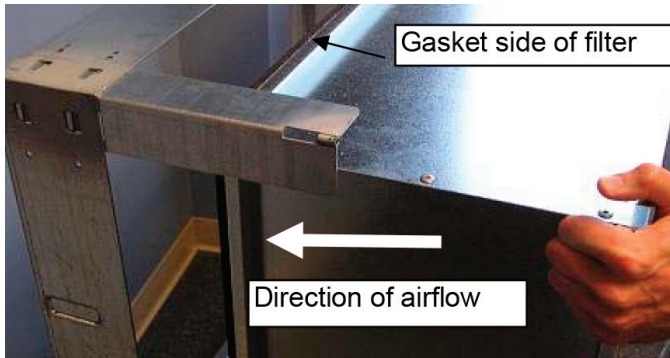
**STEP 2:** Insert the HEPA filter into the HEPA Holding Frame. The HEPA should be installed with the gasket side of the filter facing the frame. Insert the filter as far into the frame as possible, so that the gasket material is contacting the frame. See [Figure 36](#).

The filter should now be resting inside of the holding frame. When installing the filters into a frame bank of multiple frames, install the lower filters first so that the upper filters can rest on the lower filters ([Figure 37](#)).

**Figure 35: Frame with Leg Extensions Installed**



**Figure 36: Insert HEPA Filter into Frame, until the Gasket Comes in Contact with the Holding Frame**

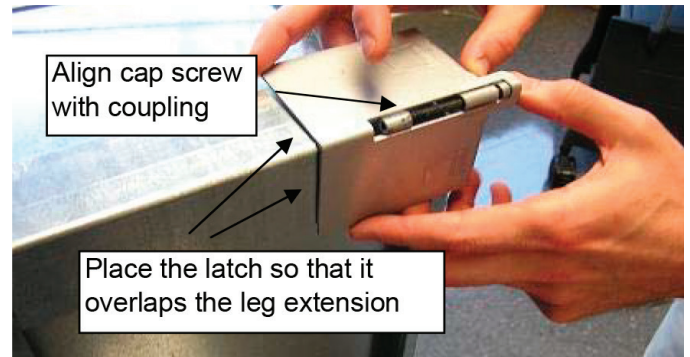


**STEP 3:** Place a latch so that it overlaps the leg extension, as shown in [Figure 38](#). Align the latches' cap screw with the threaded coupling on the end of the leg extension and tighten using the hexkey. Tighten the cap screw until there is an approximately 1/4" gap between the latch and the leg extension coupling as shown in [Figure 39](#). Repeat this step with all 4 corners.

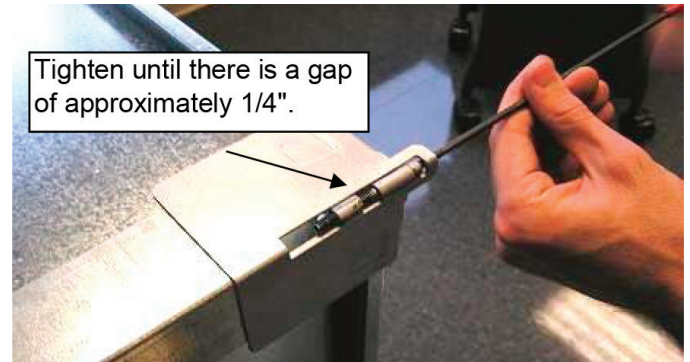
**Figure 37: Filter Placed Inside of Frame**



**Figure 38: Latch Overlapping Leg Extension**



**Figure 39: Tighten Cap Screw to 1/4" of the Coupling**

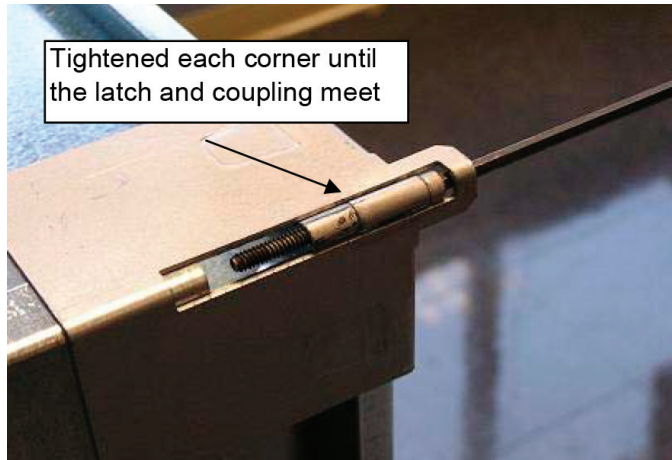


**STEP 4:** Once all four corner latches have been tightened within 1/4" of the leg extension coupling, complete the installation by tightening each corner until the latch and leg extension coupling meet. This is illustrated in [Figure 40](#).

Once all four corners have been tightened the filter should now be properly seated and sealed.

Repeat the process with all remaining filters working from the bottom to the top.

**Figure 40: Tighten until Latch and Coupling Meet**



**Figure 41: Properly Installed Filter Inside of the Frame**

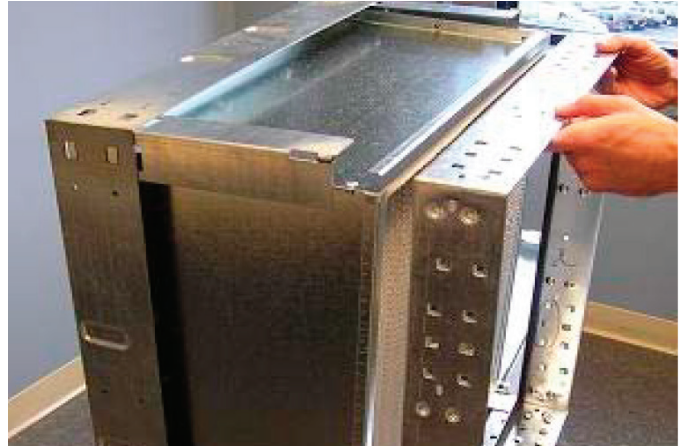


## AAF HEPA Filters with Prefilters

Follow previous steps 1-2, then continue straight to step 5.

**STEP 5:** The prefilter holding frame should be placed directly in front of the HEPA filter as shown in [Figure 42](#).

**Figure 42: Positioning of the prefilter frame**

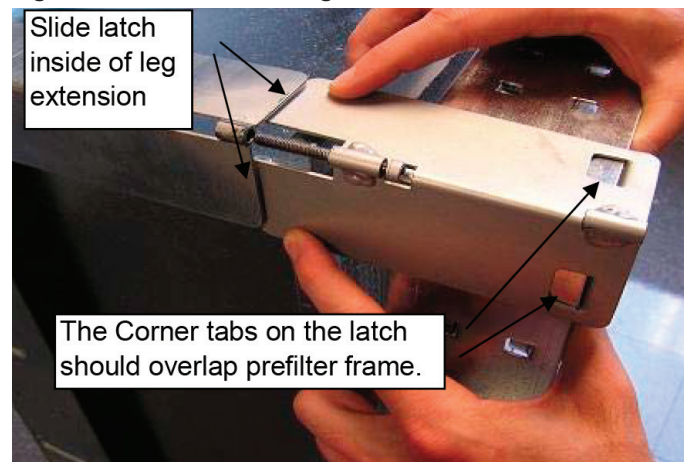


**STEP 6:** Place a latch so that the 2 tabs of the latch overlap the prefilter frame on each side of the corner. Slide the latch inside of the leg extension and align the latches' cap screw with the threaded coupling on the end of the leg extension and tighten using the hexkey. See [Figure 43](#).

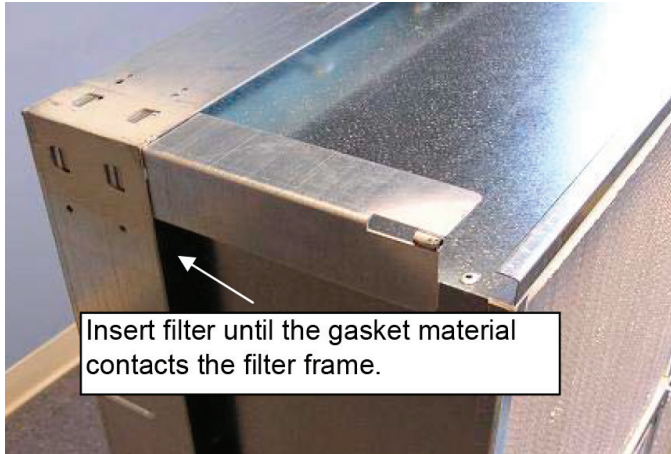
Tighten the cap screw until there is an approximately 1/4" gap between the latch and the leg extension coupling as shown in [Figure 44](#). Repeat this step with all 4 corners.

**STEP 7:** Once all four corner latches have been tightened within 1/4" of the leg extension coupling, tighten each corner until the latch and leg extension coupling meet. This is shown in [Figure 45](#).

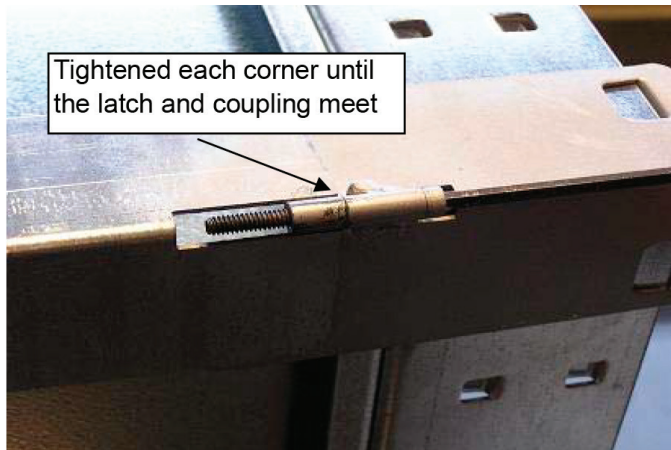
**Figure 43: Latch Positioning for Prefilter Frame**



**Figure 44: Tighten Cap Screw to 1/4" of the Coupling**



**Figure 45: Tighten until Latch and Coupling Meet**



Once all four corners have been tightened the HEPA filter should now be properly seated and sealed.

Repeat the process with all remaining filters working from the bottom to the top.

**Figure 46: Properly Installed HEPA Filter**



**STEP 8:** To complete the installation, add the appropriate prefilter latches to the prefilter holding frame. Once latches are installed, place the prefilter in the frame, secure with the latches and the installation is complete.

Repeat with all remaining prefilters and frames.

**Figure 47: Installation of Prefilter into Frame**



**Figure 48: Completed Assembly**



## Multizone Assembly

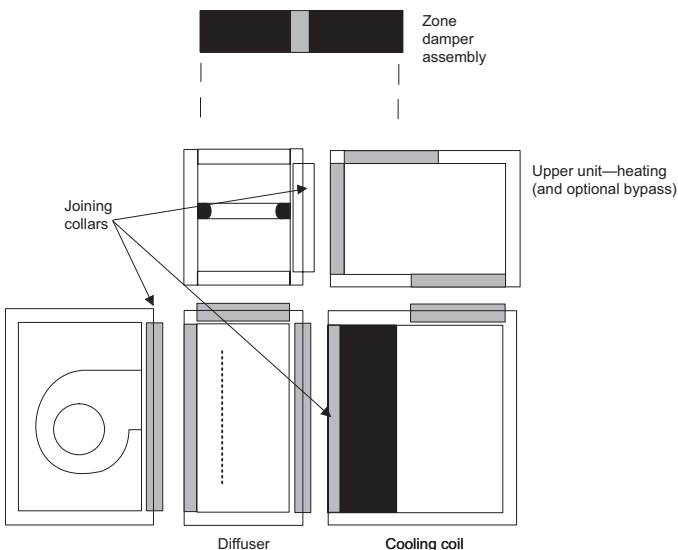
The multizone section may ship completely assembled or it may ship in numerous pieces. Whether the section ships in a single piece or multiple pieces depends on customer requirements and the unit size. When a multizone section is over 90" high or 90" wide, split it into sections for shipping.

The unit may ship in 1, 2, 3, 4, or 5 separate pieces, see [Figure 50](#). Typically, the multizone damper assembly ships separately (see [Multizone Damper Assembly](#) and [Figure 50](#)) and must be attached at the job site. Attach the damper after the other components are assembled. Use the instructions below for assembling the multizone section (also refer to [Figure 50](#)).

1. If the diffuser and the cold deck section ship separately, join them together first. The joining collar mounted in the diffuser fits into the entering air side of the coil section. Line up the two sections and fasten together.
2. Once the diffuser and cold deck sections are joined, lift the hot deck and bypass sections in place on top of the diffuser/ cold deck section. If possible, assemble the hot deck and bypass section (if there is one) together before lifting on top. There always is a joining collar in the diffuser. The joining collar provides the seal between the sections joints. It is important to line up and fit the collar in the hot deck and bypass section. For vertical applications, the cold deck also has a joining collar in the discharge opening. This collar fits in the bottom of the vertical bypass section.
3. After the components in the multizone are fitted together, fasten the joining plates to the corners in the unit exterior.
4. If a damper was ordered, assemble it to the section (see [Multizone Damper Assembly](#) and [Figure 50](#)).

**NOTE:** Verify that the joining collars are aligned to seat into the gasket. Straighten any collars distorted from shipping or from rigging.

**Figure 49: Multizone Sections Assembly**



## Multizone Damper Assembly

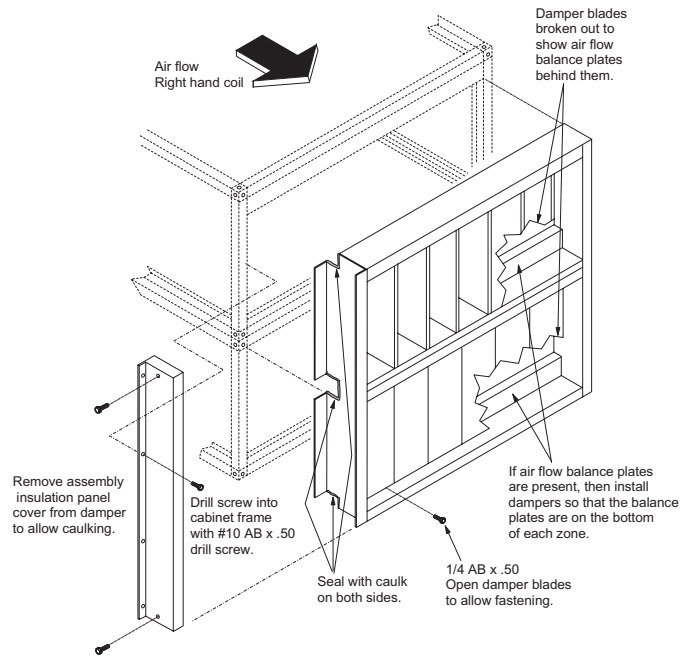
When a multizone unit is ordered with dampers, depending on the multizone configuration and size, the damper assembly may ship separately (all horizontal and units with a total height over 90").

When the dampers are not factory assembled to the unit, they ship to the job site on a skid. An assembly kit with screws and an instruction drawing are included with the damper for field assembly to the unit.

To assemble:

1. First remove the side plate that encloses insulation from both sides of the damper assembly.
2. Lift the damper assembly into position ([Figure 50](#)).
3. Fasten the assembly to the frame channels within the multizone openings.
4. Use caulking to seal up the areas around the unit frame channel to prevent any air leakage.
5. After caulking, put the side plates back in place and secure. Damper shaft extensions are provided on both ends of the damper assembly for actuation. The dampers are linked together by a linkage bar on both ends of the damper. The linkage bar is cut at the time of installation to divide the damper into the required number of zones (refer to [Multizone Damper Adjustment](#) on page 22).

**Figure 50: Multizone Damper Assembly**

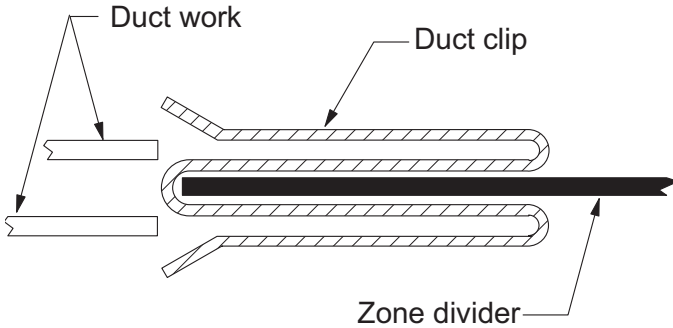


## Duct Connections

Use flexible connectors on the outlet and inlet duct connections of all units. Each zone divider has a W-shaped duct clip. Insert ductwork into this clip (Figure 51).

Support all ductwork independently of the unit or unit casing.

Figure 51: Duct Connectors



**NOTE:** Before connecting to ductwork, refer to Multizone Damper Adjustment below.

## Multizone Damper Adjustment

The installer must clear the damper assemblies of construction dirt and debris. These materials result in higher torque requirements and may bend or damage damper components.

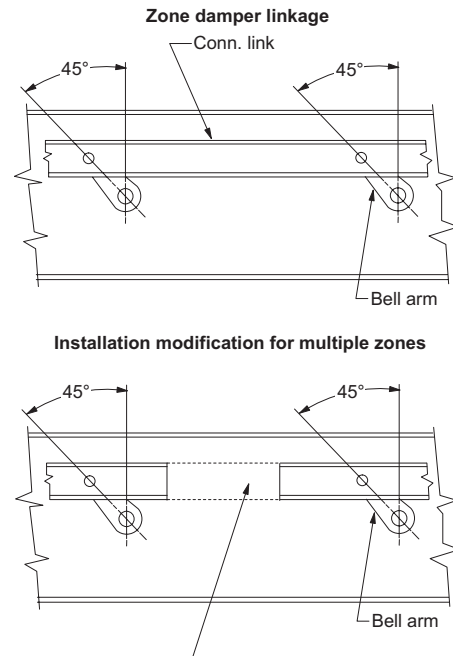
Before you begin:

1. Verify that dampers are square and operating smoothly before ducting.
2. Install duct access panels on the downstream damper for inspection and maintenance.

If multizone dampers do not close properly, adjust the blades as follows:

1. Loosen set screws in bell arms for all zones.
2. Close all cold deck dampers tightly.
3. Move bell arms so they are at a 45° angle to the vertical center when viewing the zone dampers from the cold deck end of the damper section (Figure 52).
  - a. Two-deck zone dampers—The cold deck closes when the bell arms are 45° from the vertical center. The hot deck closes when the bell arms are 45° clockwise from the vertical center.
  - b. Three-deck zone dampers—The cold deck closes when the bell arms are 45° clockwise from the vertical center. The hot deck closes when the bell arms are 45° counterclockwise from the vertical center.
4. Tighten set screws on bell arms while holding the dampers closed.
5. All zone damper blades should close properly. If one or a few zones do not close completely, repeat the procedure for these zones.

Figure 52: Bell Arms at 45° Angle to Vertical Center




To divide the damper section into multiple zones, cut and remove sufficient connecting link to allow adjacent zones to operate independently.

**NOTE:** The damper blades on two-deck dampers seal through several degrees of shaft rotation. The damper blades can rotate 360° and do not engage a stop. The hot deck blades are mounted at a 90° to the cold deck blades. Before installing the zone duct, set up linkages and dampers and adjust. If adjustment is required and access to the blades is restricted, observe the cold deck blade position by removing the cabinet panel on the coil section.

## Multizone, Mixing Box and Economizer Damper Torque Requirements

On multizone units, the actuator must drive the connection link for proper damper actuation. Do not activate multiple dampers must from the shaft extension opposite the connection link.

## Mounting Actuators

 <b>CAUTION</b>
Maximum damper rotation is 70°. Maximum shaft torque is 205 inches/pound. Greater rotation or torque can cause equipment damage.

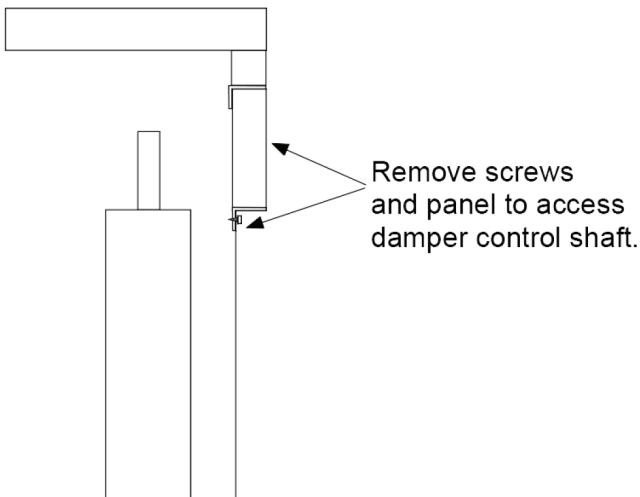
The installing contractor is responsible for the mounting of all field-installed actuators. No provisions are made for the location of these actuators due to the number of options and arrangements available and the variety of specific applications. Typically, actuators are mounted inside the cabinet. Provide proper support for the actuator to avoid excessive stress in the cabinet, linkage, or damper shafts.

Fresh air and return air dampers can be linked together and driven from the same actuator if the dampers are the same size. If the dampers are different sizes, they must be driven by separate actuators and controlled appropriately. Exhaust dampers are always driven by a separate actuator.

**EXCEPTION:** For the angled economizer, the fresh air and return air dampers must always be driven by separate actuators.

A typical rotary electric actuator can handle up to 40 sq. ft. of damper. For pneumatic actuators, allow 5 in-lb per square foot of damper area.

**Figure 53: Filler Panel above Dampers on Angled Economizer Sections**



## Angled Economizer Actuator Access

Access to the fresh air and exhaust air damper drive shafts of the angled economizer is recommended internally through the upstream or downstream sections of the unit. If no internal access is available, a removable filler panel is located above each damper to provide access to the damper drive shaft.

**NOTE:** The hood and damper must be removed to remove the panel (Figure 53). There are two options for gaining access to the return air damper drive shaft:

1. If the unit has a housed return fan or plenum exhaust fan, an access section should be located immediately downstream of the economizer section for access to the return air damper drive shaft.
2. If the unit has a plenum return fan or housed exhaust fan, access to the return air damper drive shaft can be obtained via the fan section's access door and the removable filler panel located above the return air damper.

## Face Bypass Damper Torque Requirements

Face and bypass dampers may or may not be linked together. When dampers are placed before a single bank of coils, they always are linked together and require a single actuator. When dampers bypass a stacked or staggered coil, the dampers are not linked and require multiple actuators. Unit sizes 040 to 090 provided with external face and bypass require three actuators. Other arrangements with stacked or staggered coils require two actuators. A damper shaft extension is provided. Normally, the shaft extension is located on the drive side of the unit, but it can be moved to the other side.

Face and bypass dampers have a torque requirement of 10 in-lbs per square foot of damper face area.

## Isolation Dampers for Multiple Fans

Optional isolation dampers can be provided on multiple fans to prevent backflow through a fan that is turned off for service. These isolation dampers are not intended to be used to control flow through the fan. The isolation damper for a fan that is going to be started must be positioned in the full open position before the fan is started. Do not start a fan with the damper located at the inlet with the damper fully or partially closed. This can cause airflow, vibration, and sound problems that can lead to failure.

Isolation dampers can be provided with actuators that are mounted in the airstream. Actuator sizing for the isolation dampers should be based on 9 in-lb per square foot of damper.

## Piping and Coils

When designing and installing piping:

- Follow applicable piping design, sizing, and installation information in ASHRAE handbooks.
- Observe all local codes and industry standards.
- Do not apply undue stress at the connection to coil headers; **always use a backup pipe wrench.**
- Support pipework independently of the coils.

## Water Cooling Coils

- Water supply, water return, drain, and vent connections extend through the end panel of the coil section. All connections are labeled on the end panel.
- Water supply and water return connections are typically male NPT iron pipe.
- When installing couplings, do not apply undue stress to the connection extending through unit panel. **Use a backup pipe wrench to avoid breaking the weld between coil connection and header.**
- Follow recommendations of the control manufacturer regarding types, sizing, and installation of controls.

## Direct Expansion Coils

- The coil distributor and suction connection extend through the end panel of the coil section.
- Check nozzle in distributor for proper tonnage.
- When a field supplied thermostatic expansion valve is used, it is located outside the unit and connected directly to the distributor. Do not apply heat to the body of the expansion valve.
- The thermostatic expansion valve must be of the external equalizer tube type. Connect the 1/4" diameter external equalizer tube provided on the coil to connection on expansion valve.
- Use care when piping the system to see that all joints are tight and all lines are dry and free of foreign material. For typical refrigerant piping, see condensing unit product manual.

## Steam Coils

### Piping (see [Figure 54](#))

- All steam coils in units are pitched toward return connection.
- Steam supply and steam return connections typically are male NPT iron pipe and are labeled on the end panel of coil section. Connections extend through the coil section end panel.
- When installing couplings, do not apply undue stress to the connection extending through unit panel. **Use a backup pipe wrench to avoid breaking the weld between coil connection and header.**
- Support piping independently of coils and provide adequate piping flexibility. Stresses resulting from expansion of closely coupled piping can cause serious damage.
- Do not reduce pipe size at the coil return connection. Carry return connection size through the dirt pocket, making the reduction at the branch leading to the trap.

### Coils

- Install vacuum breakers on all application to prevent retaining condensate in the coil. Generally, the vacuum breaker is connected between the coil inlet and the return main. The vacuum breaker should be open to the atmosphere, and the trap design should allow venting of large quantities of air.
- Do not drip supply mains through the coil.
- Do not attempt to lift condensate when using modulating or on/off control.



## Traps

- Size traps in accordance with the manufacturers' recommendations. Make sure that the required pressure differential is always available. Do not undersize.
- Use float and thermostatic or bucket traps for low pressure steam. On high pressure steam, use bucket traps. Use thermostatic traps only for air venting.
- Use bucket traps for on/off control only.
- Locate traps at least 12 inches below the coil return connection.
- Multiple coil installation
- Individually trap each coil or group of coils that is controlled individually trapped.
- Coils in series—use separate traps for each coil, or bank of coils.
- Coils in parallel—a single trap can be used, but an individual trap for each coil is preferred.
- Do not attempt to lift condensate when using modulating or on/off control.
- With coils arranged for series airflow, use a separate control on each bank or coil in the direction of airflow.

## Valves

- Do not use modulating steam valves on high pressure systems.
- Properly size modulating valves. **Do not undersize.**
- Freezing conditions (entering air temperatures below 35°F).
- Daikin Applied strongly recommends 5JA, 8JA, 5RA and 8RA coils.
- Supply 5 psi steam to coils at all times.
- Do not use modulating valves. Provide control by face and bypass dampers.
- Consider using two or three coils in series with two position steam control valves on the coil or coils that handle 35°F or colder air. Use a modulating valve on the downstream coil to provide the desired degree of control.
- Thoroughly mix fresh air and return air before it enters the coil. Also, to obtain true air mixture temperatures, properly locate temperature control elements.
- As additional protection against freeze-up, install the trap sufficiently below the coil to provide an adequate hydrostatic head to remove condensate during an interruption in the steam pressure. Estimate three feet for each 1 psi of trap differential required.
- On startup, admit steam to coil ten minutes before admitting outdoor air.
- Close fresh air dampers if steam supply pressure falls below the minimum specified.

## Pipe Chases

Follow these guidelines when routing field supplied internal piping through the bottom of a unit.

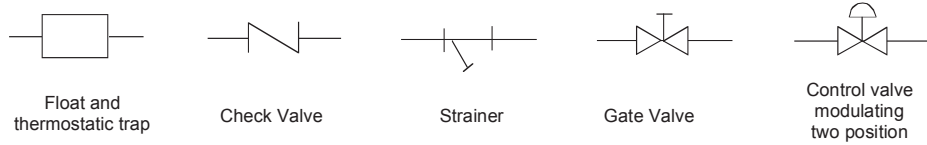
- Determine what style base and options were selected:
  - Was an uninsulated sheet metal pipe chase cover selected?
- Determine the number and location of holes required for piping as follows:
  - Check that adequate space is available inside the unit for pipe routing.
  - Hole(s) must be located fully within panels or sheet metal opening covers. Do not run pipes through 4" wide intermediate panels or on the very edge of the panel.
  - Do not place holes in a location that impedes access to key maintenance components such as filters and fan assemblies.
  - Do not place holes in a location where the pipe will block airflow or obstruct hinged access doors.
- Once a proper location is determined:
  - If no pipe chase cover is present:
    - a. Drill a small pilot hole completely through the bottom cabinet panel, then using a sharp hole saw or saber saw, cut the desired final hole size and smooth the edges of the cut. or saber saw, cut the desired final hole size and smooth the edges of the cut.
  - If a pipe chase cover is present:
    - a. Remove the pipe chase cover.
    - b. Drill a small pilot hole completely through the pipe chase cover, then using a sharp hole saw or saber saw, cut the desired final hole size and smooth the edges of the cut.
  - After installation of the piping, seal the hole(s) in the bottom cabinet panel or pipe chase cover.
    - a. Seal the holes to divert any moisture away from the opening and prevent moisture leakage through the holes.
    - b. Recommended sealing options include: flashing material, caulk, spray foam, cork tape, industrial or commercial grade silicone sealant, duct seal compound, or other similar sealing material.
    - c. Pipe chase covers are not guaranteed to be airtight or watertight, but the pipe chase cover may be sealed in a similar manner to the other penetrations of the pipe chase cover if desired.

**NOTE:** The installer is responsible for ensuring the penetrations are fully sealed.

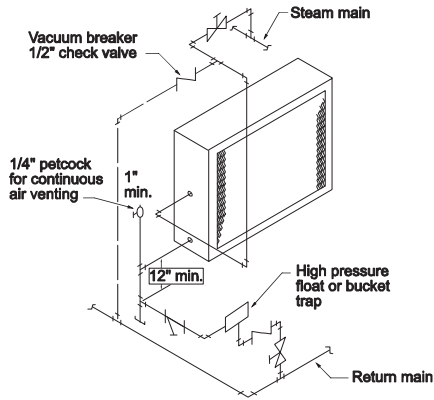
**NOTE:** Do not support piping off of the unit, or coil connections.

**NOTE:** It is extremely important to seal each hole or penetration securely so that they are airtight and watertight.

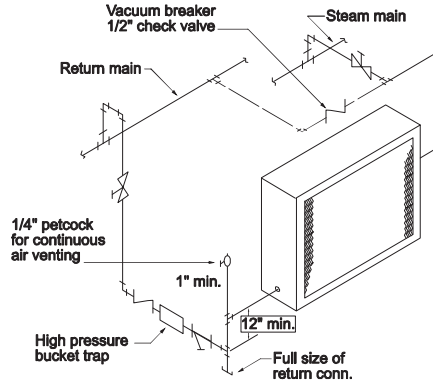
**Figure 54: Piping Arrangements**



**High Pressure (over 25 psi)**

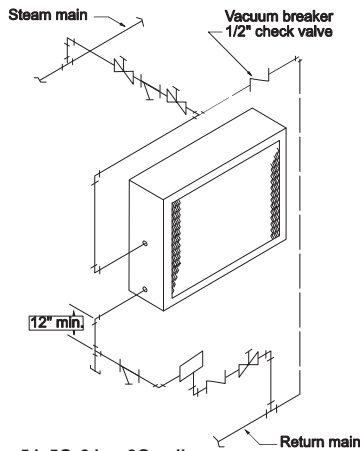


**5GA or 8GA coils.** Note that the addition of a vacuum breaker to permit the coil to drain during shutdown.

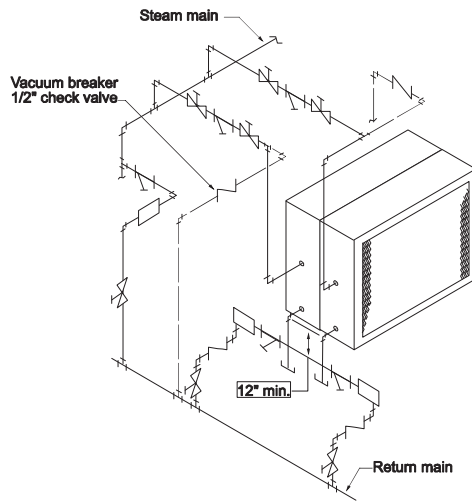


**5TA, 8TA, or 5HA coils.** Condensate is lifted to overhead return main

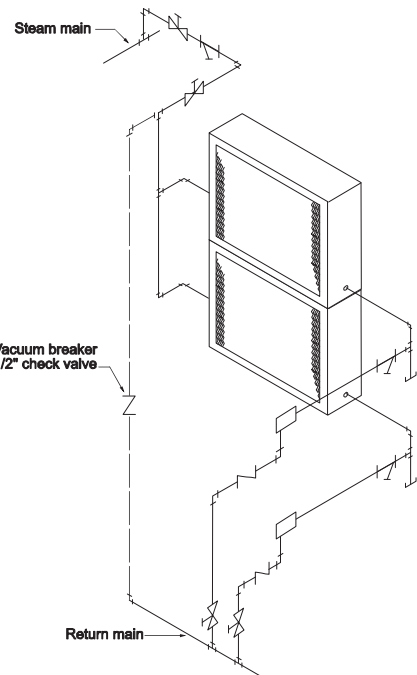
**Low Pressure (to 25 psi)**



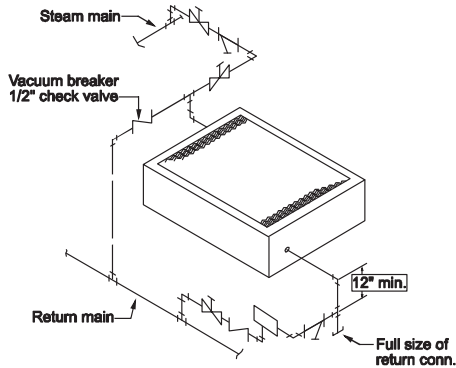
**5J, 5G, 8J or 8G coils.**



**5JA or 8JA coil.** Installed in series. Note that each coil must have a separate control valve and trap.



**5RA, 8RA, or 5SA coils.** Banked two high, individual trapping of each coil as shown is preferred.



**5RA, 8RA, or 5SA coils.** Installed

## Water Heating Coils

### ⚠ CAUTION

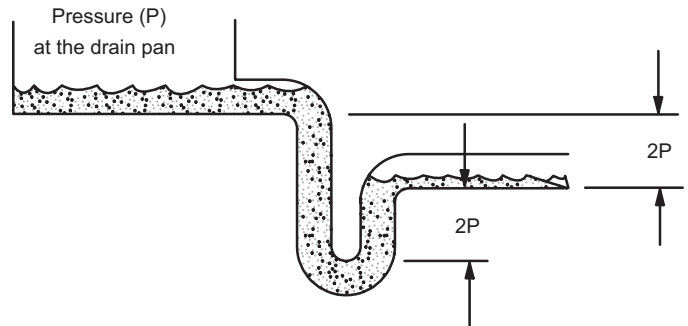
Improper installation, use, or maintenance of water heating coils can cause equipment damage. Read and follow instructions carefully.

- Water supply and water return connections extend through the end panel of the coil section. All connections are labeled on the end panel.
- Water supply and water return connections are male NPT iron pipe.
- When installing couplings, do not apply undue stress to the connection extending through unit panel. Use a backup pipe wrench to avoid breaking the weld between the coil connection and header.
- Follow recommendations of the control manufacturer regarding types, sizes, and installation of controls.
- Do not use hot water coils with entering air below 40°F.
- If fresh air and return air are to be heated by a hot water coil, carefully design the system to provide thorough mixing before air enters the coil.
- To prepare coils for winter operation, see [Winterizing Water Coils](#) on page 56.

## Drain Pan Traps

Run drain lines and traps full size from the drain pan connection. Install drain pan trap to allow condensate to drain freely. On both blow-through and draw-through units, the trap depth and the distance between the trap outlet and the drain pan outlet must be twice the static pressure in the drain pan section under normal operation so the trap remains sealed ([Figure 55](#)).

**Figure 55: Allow Adequate Distance Between Trap Outlet and Drain Pan Outlet**



## Internal Isolation Assembly Adjustment

On units with internally isolated fan and motor assemblies, the assemblies are secured for shipment.

### Before Operating the Unit

Remove the shipping brackets and tie-down bolts (refer to [Figure 57](#), [Figure 58](#) and [Figure 59](#)) and discard. The shipping brackets located on the opposite drive side of the unit are difficult to access from the drive side of the unit. Either remove them before the unit is assembled, or remove the panel on the opposite drive side to gain access.

The spring isolators under the four corners of the fan and motor assembly are factory adjusted while the fan was not running. With the unit operating at normal cfm and static pressure, all the isolators should be at the same height opening ([Table 1](#) through [Table 5](#)). If adjustments are required, loosen the 1/2" cap screw on top of the isolator and turn the adjusting bolt to lower or raise the fan and motor base. Retighten the cap screw when adjustments are completed.

**Table 1: Motor Beside Fan Spring Mount Adjustments**

Spring Mount Adjustment at Rest			
Isolator Position	Top or Bottom Horizontal H	Downblast H	Upblast H
<b>Unit Sizes 003 – 035</b>			
1	3.75	3.75	4.25
2	4.25	3.75	4.25
3	4.25	3.75	4.25
4	3.75	3.75	4.25
<b>Unit Sizes 040 – 090</b>			
1	6.00	6.00	6.50
2	6.50	6.00	6.50
3	6.50	6.00	6.50
4	6.00	6.00	6.50

**Table 2: Motor Behind Fan Spring Mount Adjustments**

Spring Mount Adjustment at Rest			
Isolator Position	Top or Bottom Horizontal H	Downblast H	Upblast H
<b>Unit Sizes 003 – 035</b>			
1	6.75	6.75	6.75
2	6.75	6.75	6.75
3	6.75	6.75	6.75
4	6.75	6.75	6.75
<b>Unit Sizes 040 – 090</b>			
1	6.75	6.75	6.75
2	6.75	6.75	6.75
3	6.75	6.75	6.75
4	6.75	6.75	6.75

For models 040 through 090 with housed fans, the isolators should be at equal height (6") during fan operation. Center the fan outlet in the outlet panel opening. If adjustment is required, loosen the bolt on top of the isolator assembly. Turn the adjustment nut below the fan frame to lower or raise the fan motor and frame assembly. Retighten the bolt on top of the isolator assembly.

**Table 3: Class II Belt-Drive Plenum Fan Spring Height**

Fan Size	Isolator Type	Operating Height (in.)
13–16	Standard 2" Deflection	4.5
18–36	Standard 2" Deflection	4.0
13–36	Seismic	4.0
40–60	All	6.75

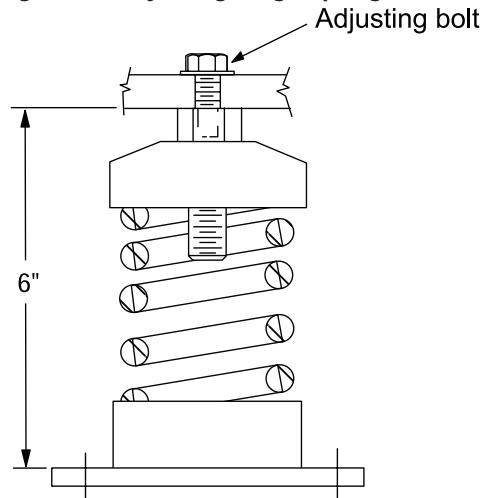
**Table 4: Class III Plenum Fan Spring Height**

Cabinet Width (in.)	Isolator Type	Operating Height (in.)
Width < 108	All	4.0
Width ≥ 108	All	6.75

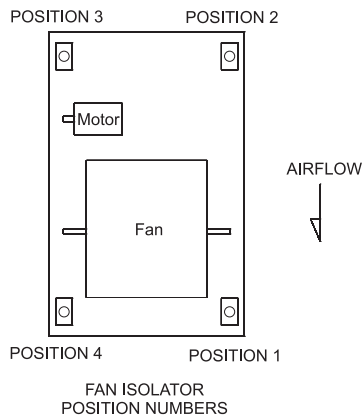
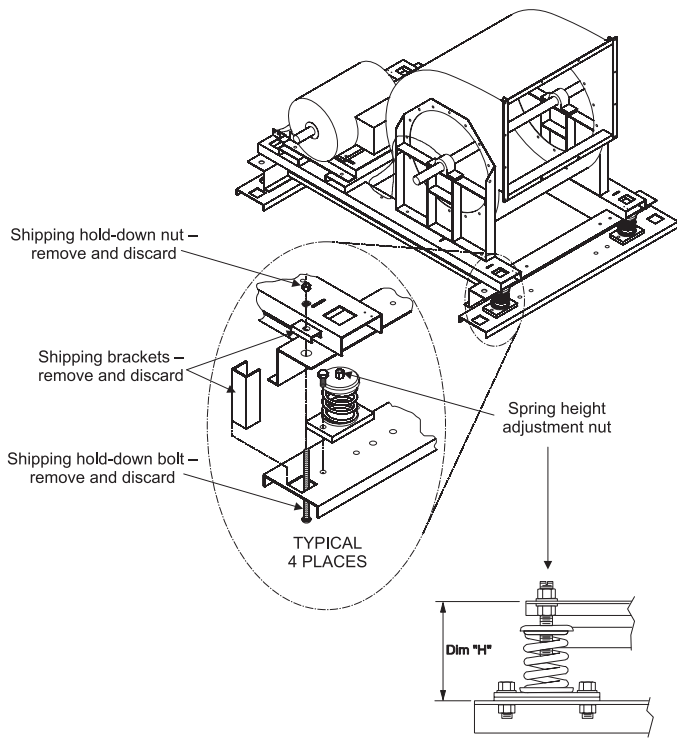
**Table 5: Class II Direct-Drive Plenum Fan Spring Height**

Fan Size	Isolator Type	Operating Height (in.)
11–36	All	4.0
40–44	All	6.75

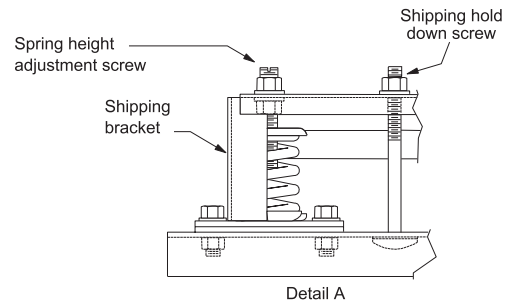
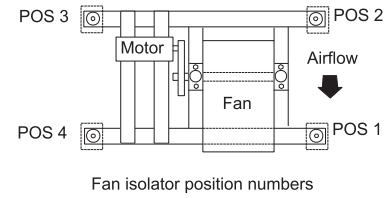
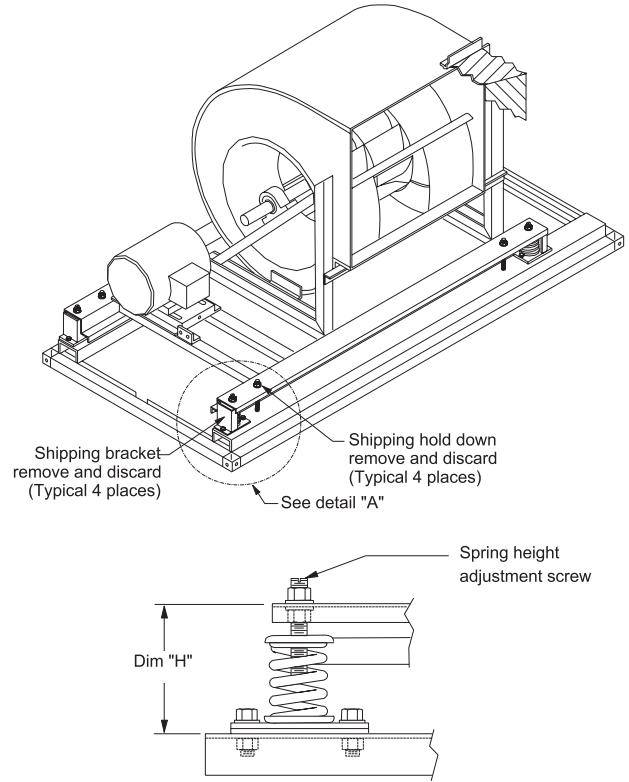
**Figure 56: Adjusting Large Spring Mount Assembly**



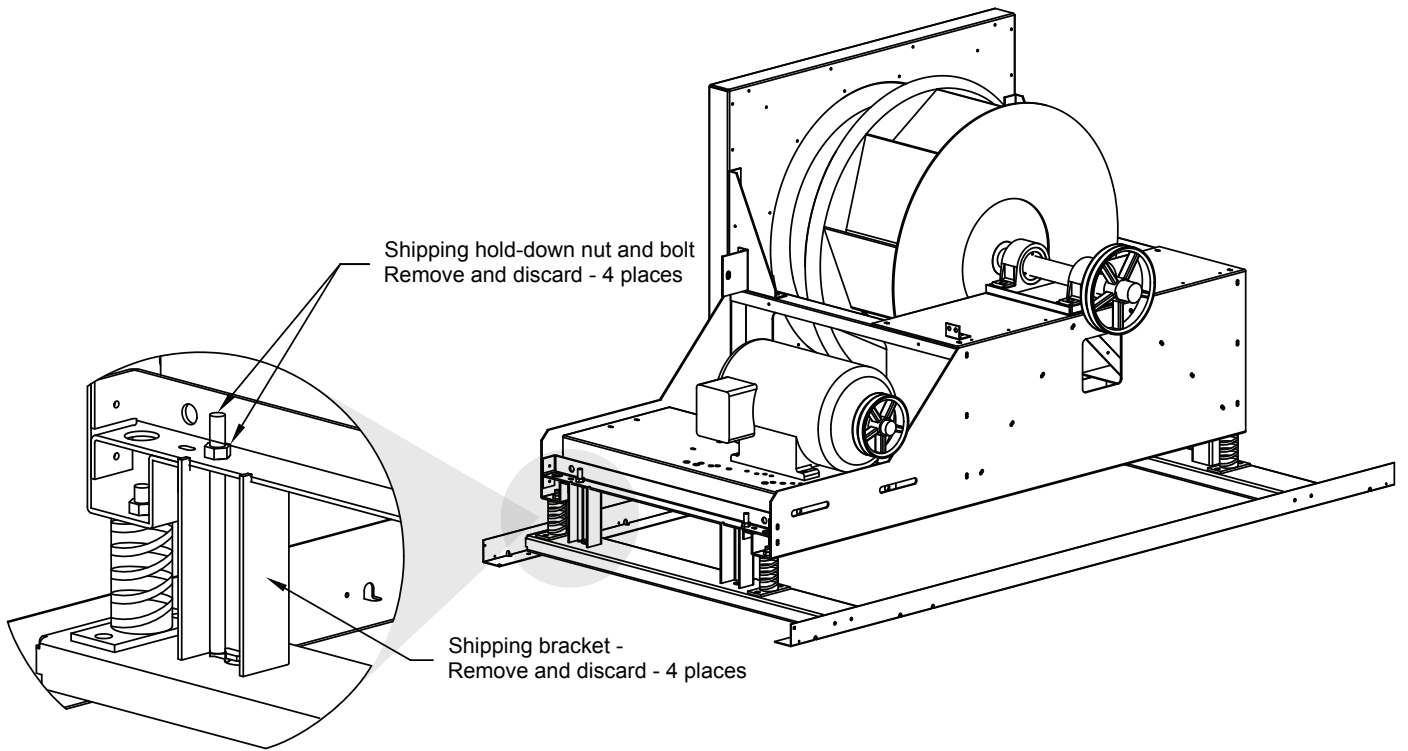
**Figure 57: Removing "Motor Behind" Shipping Brackets**



**Figure 58: Removing "Motor Beside" Shipping Brackets**



**Figure 59: Plenum Fan Typical Shipping Brackets**



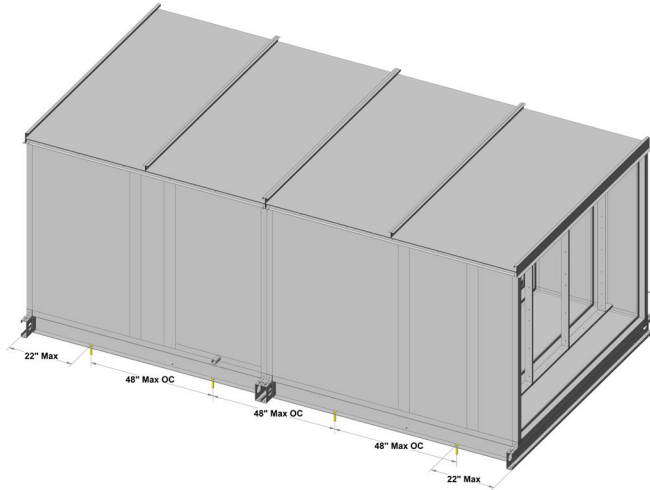
## HCAI Seismic Anchoring/Mounting

For seismic stability of the unit, additional anchoring and mounting procedures are required. The anchoring options and corresponding spectral response acceleration are given in [Table 6](#). Holes in the Vision/Skyline base frame are to be field drilled. Any mounting hardware is to be field supplied.

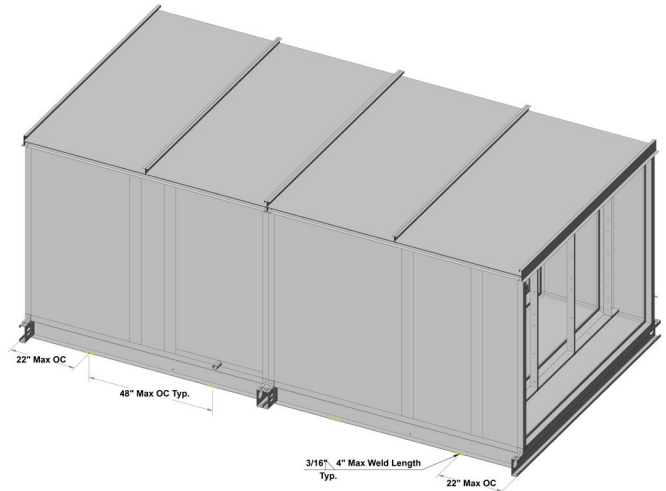
**Table 6: HCAI Mounting**

Attachment Method	SDS	Attachment System (by Others)	
		Spacing	System
Bolted attachment to steel ( <a href="#">Figure 60</a> )	1.93	48	5/8" DIA SAE Grade 5
Welded attachment to steel ( <a href="#">Figure 61</a> )	1.84	48	3/16" Weld Leg and 4" welded length
Bolted attachment to Concrete ( <a href="#">Figure 62</a> )	1.68	24	Hilti HDA-P M16 x 190/40 with 7.48" embedment

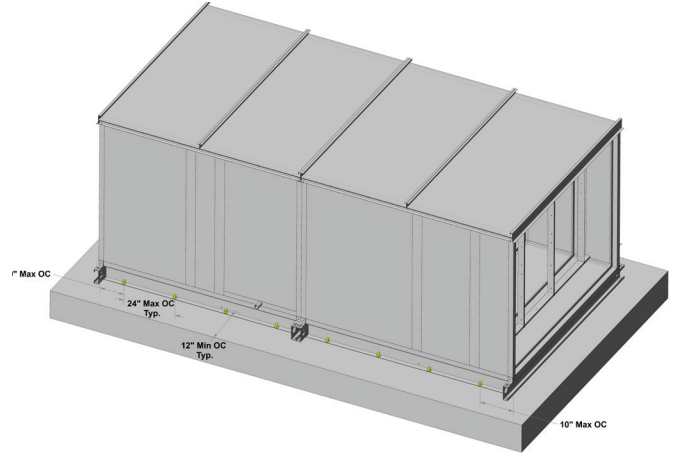
**Figure 60: Unit with Base Frame Mounted on Steel**



**Figure 61: Unit with Base Frame Welded**




**Figure 62: Unit with Base Frame Mounted on Concrete**




# Electrical Installation

## Wiring

 **DANGER**

**Capacitor Hazardous Voltage!** Failure to disconnect power and discharge capacitors before servicing will result in serious injury or death. Disconnect all electric power (including remote disconnects) before servicing. Perform lockout/tagout procedures to ensure that power can not be energized. For variable frequency drives, or other energy storing components that have been furnished and mounted by either Daikin Applied, or by others, refer to the specific manufacturer's literature for allowable waiting periods for discharge of capacitors. Verify capacitors have been discharged using an appropriate voltmeter.

 **DANGER**

- This equipment is not suitable for use in high impedance grounding or neutral systems.
- Connect only to low impedance, solidly grounded electrical supply systems.

Failure to follow these instructions will result in death or serious injury.

 **CAUTION**

**Use copper conductors only!** Failure to use copper conductors can result in equipment damage.

- Electrical service to each fan must correspond to the rated voltage on the motor or electrical panel nameplate and conform to the National Electric Code and local restrictions.
- Connect each fan section metal frame to the building electrical ground.
- A door electrical interlock is not provided as standard.
- Thermal motor protection is external to the unit. Unless the unit is provided with a variable frequency drive (VFD) or a unit mounted starter, thermal protection and a disconnect switch provision per electric codes are provided by others.
- When the unit is factory provided with a disconnect switch, starter or a variable frequency drive (VFD), the components are mounted on the outside of the unit cabinet. Factory wiring is provided from the device to the unit internal motor.
- All electrical components must be grounded to the building central ground. Suitable ground wires and/or (bonding) lugs are provided for all motors, disconnect switches, starters, and variable frequency drives. Provide dedicated ground (bonding) copper conductors in accordance with local and national codes.
- For units provided with a motor only or with an external junction box, wire connections are made with suitable wire nuts or connectors for the gauge wires provided.

- For units provided with a disconnect switch or starter, field wiring will be terminated to lugs. Wire size and lug torque requirements are shown on the unit electrical schematic provided in the component print pocket. All power supply wire connections must be torqued as shown.
- When the unit is provided with a VFD only, refer to the VFD manual for wire size and torque requirements. For instances where multiple motors are being driven by a single VFD, be sure to set up the VFD and size the wiring according to the power requirements of all motors that are being driven by that VFD.
- When not being serviced, close and secure electrical panel doors to prevent ingress of moisture and airborne contaminants.

## Control Wiring

- Access to the VFD is through the fan cabinet access door for single fans. Provide shielded cable only as described in the provided VFD manual. Route wire through the panel so that it does not interfere with any other components or access doors. Do not drill through drip pans or drain pans. Refer to the provided VFD installation manual for detailed control wiring instructions.
- For multiple fans in parallel, the VFD(s) are mounted inside of the electrical enclosure, which is mounted on the exterior of the fan section. When multiple fan sections are provided with multiple VFDs, they must be set up so that the fans always start simultaneously and are set to ramp up and down together. Do not attempt to run fans in parallel at different speeds as this can result in uneven airflow that can cause performance, sound, and vibration problems that can lead to failure. Provided that the fan is capable of running fast enough, the motor is sized appropriately, and the VFD can be sped up within its rated continuous output, VFDs may be operated up to a maximum recommended frequency of 90 Hertz for 1800 RPM and slower motors. Motors that are 3600 RPM may be operated up to a maximum speed of 4000 RPM or 66.7 Hertz provided the fan is rated that high. Operation above 4000 RPM can damage motor bearings and is not recommended.

## Wiring Penetrations

- Seal any panel penetrations for wiring or conduit per the panel cutting procedure instructions within this document
- Seal any other wiring or conduit penetrations in accordance with NEC, relevant codes, and in order to maintain the enclosure rating, only use fittings that are approved to keep the particular rating of the individual enclosure being penetrated per relevant code or standard tables. Seal wireway openings tight enough to prevent air movement between sections and control enclosures.



# Operation

## Startup Checks

### WARNING

#### ROTATING FAN

Can cause severe injury or death. Before servicing fans, lockout and tag out power.

### WARNING

#### FIRE/ELECTRIC SHOCK HAZARD

Can cause property damage, personal injury or death. Wire fan power supply and ground motor frame in accordance with local electric codes.

### WARNING

#### Fan motor requires overload protection.

Failure to provide motor overload protection can result in fire, property damage, electric shock, personal injury, or death. Connect motor to an overload protective device rated in compliance with local electric codes.

### CAUTION

#### DO NOT OVERHEAT FAN MOTOR

High air temperatures in the fan section can cause the fan motor to burnout. On draw-through air handlers or air handlers with the fan section down the air stream from the heating section, the discharge air temperature of the heating section must not exceed 104°F (40°C).

When performing startup and service, always take thorough safety precautions. Only trained, experienced personnel should perform these functions.

## Before Starting the Unit

### CAUTION

Equipment damage due to loose fasteners represents improper start-up and equipment abuse. It is not covered by the warranty.

Before entering fan section, make sure that fan electrical power source is disconnected and locked in the OFF position.


1. Check that the unit is completely and properly installed with ductwork connected.
2. Check that all construction debris is removed and filters are clean.
3. Check that all electrical work is complete and properly terminated.
4. Check that all electrical connections are tight and that the proper voltage is connected. Phase imbalance must not exceed 2%.
5. Do not grease ball bearings on the fan shaft and motor before startup. They are prelubricated.
6. Check tightness of screws in bearings and fan wheel(s). If retightening is needed, position the fan wheel(s) per [Table 7 on page 34](#) through [Table 9 on page 35](#) and [Table 10 on page 36](#) through [Table 11 on page 36](#). Torque set screws per [Table 12 on page 36](#).
7. Check alignment of fan and motor sheaves and belt tension. Adjust if necessary. Check tightness of sheave setscrews and/or capscrews (refer to [page 36](#)).
8. Leak test the thermal system to verify that connections are tight.
9. Check that the condensate drain is trapped.
10. Rotate the shaft by hand to be sure it is free.
11. If multiple fans are supplied with a block off plate and it is installed on one of the fans, make sure to only start the fans without the block off plate. Do not start any fan that has the block off plate installed on it.
12. If multiple fans are supplied with isolation dampers, make sure the isolation dampers are fully open before starting the fans.

## VFD Setup

Fans ordered with VFDs that were factory installed are setup and tested prior to shipment. Prior to starting the fan(s), double check the VFD settings according to the recommendations in the VFD manual.

Once the correct VFD settings are verified, the fans should be run through a sweep of the full range of operating speeds that are expected to check for any vibration issues. If any areas of concern are located, it is recommended to lock out those frequencies using the VFD (see lock out frequencies or skip frequencies in the VFD manual). This will ensure that the fans will never operate continuously at those points, but will rather pass through them to get to the desired points of operation.

## Fan Startup

 <b>WARNING</b>
<b>ROTATING FAN</b>
Can cause severe injury or death. Before servicing fans, lockout and tag out power.

Start and run fan. See [on page 35](#) for proper fan rotation. Observe the rotation. If the fan operates backward, reverse two legs of the three-phase supply power.

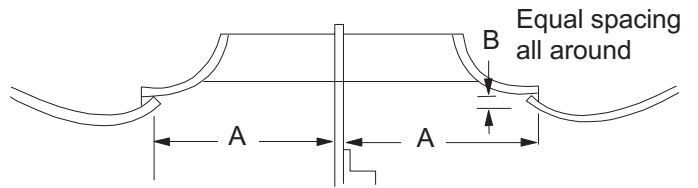
**NOTE:** Variable pitch fan drives usually are provided for operation in the mid-speed adjustment range. However, the drives usually ship with the adjustment opened up for minimum fan speed. Adjust the drives for the proper airflow. See [Fan Drive Adjustments on page 50](#).

## After 48 Hours of Operation

1. Disconnect and lock electrical power source.
2. Check tightness of all bearing, wheel, and sheave setscrews (or capscrews). Refer to [Table 12](#).
3. Recheck belt tension and adjust if necessary. Belts tensioned sufficiently to slip one to two seconds at startup will perform satisfactorily, extending life and reducing If retensioning is necessary, be certain to retain sheave alignment.

## Fan Wheel Alignment

**Figure 63: Wheel-to-Inlet Funnel Relationship—Fan Wheels (Housed)**



**Table 7: Wheel-to-Inlet Funnel Relationship—Fan Wheels(Housed)**

Airfoil <sup>1</sup> (in.)					
Unit sizes 003 to 035			Unit sizes 040 to 090		
Diameter	A <sup>2</sup> (mm)	B <sup>3</sup> (mm)	Diameter	A <sup>2</sup> (mm)	B <sup>3</sup> (mm)
13.22	4.56 (116)	0.21 (5.33)	20.00	7.19 (183)	0.31 (7.87)
14.56	5.06 (129)	0.21 (5.33)	22.25	7.69 (195)	0.33 (8.38)
16.18	5.62 (143)	0.21 (5.33)	24.50	8.56 (217)	0.31 (7.87)
17.69	6.90 (175)	0.22 (5.59)	27.00	9.47 (241)	0.63 (16.00)
21.56	7.59 (193)	0.24 (6.10)	30.00	10.47 (266)	0.39 (9.91)
24.00	8.45 (215)	0.23 (5.84)	33.00	11.75 (298)	0.38 (9.65)
—	—	—	36.50	325 (12.78)	0.38 (9.65)
—	—	—	40.25	363 (14.31)	0.50 (12.70)

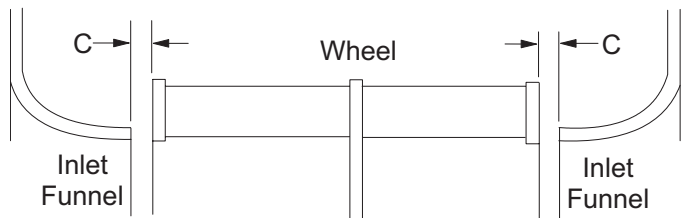
Note:

<sup>1</sup>To obtain rated air performance, dimensional relationship must be held.

<sup>2</sup>To obtain dimension A, loosen setscrews in wheel hub(s), shifting wheel(s) axial as needed, retightening setscrews.

<sup>3</sup>To obtain dimension B, loosen screw and washer fasteners around periphery of funnel(s), shifting funnel radially as required, re-torquing fasteners.

**Figure 64: Wheel-to-Inlet Funnel Relationship—Forward Curved Fan Wheels**



**Figure 65: Wheel-to-Inlet Funnel Relationship—Forward Curved Fan Wheels**

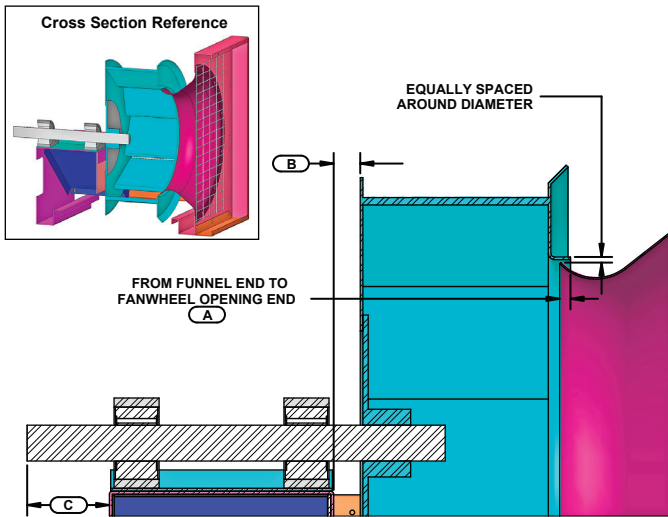
Forward Curved <sup>1</sup> (in.)			
Unit sizes 003 to 035		Unit sizes 040 to 090	
Diameter	C <sup>2</sup> (mm)	Diameter	C <sup>2</sup> (mm)
9×4	0.25 (6.35)	20 (Class 1 & 2)	0.24 (6.10)
9×7	0.13 (3.30)	22.38 (Class 1 & 2)	0.41 (10.41)
9×9	0.25 (6.35)	25 (Class 1 & 2)	0.47 (11.94)
10	0.22 (5.59)	27.62 (Class 1 & 2)	0.47 (11.94)
12	0.35 (8.89)	30 (Class 1 & 2)	0.47 (11.94)
15	0.44 (11.18)	33 (Class 1 & 2)	0.50 (12.70)
18	0.25 (6.35)	36 (Class 1 & 2)	0.75 (19.05)
20 (Class 1 & 2)	0.73 (8.54)	—	—
22½ (Class 1 & 2)	0.59 (14.99)	—	—
24½ (Class 1 & 2)	0.56 (14.22)	—	—

Note:

<sup>1</sup>To obtain rated air performance, dimensional relationship must be vibration. If retensioning is necessary, be certain to retain held.

<sup>2</sup>Adjust dimension C by loosening wheel hub setscrews, shifting sheave alignment wheel(s) axial as needed, and retightening setscrews.

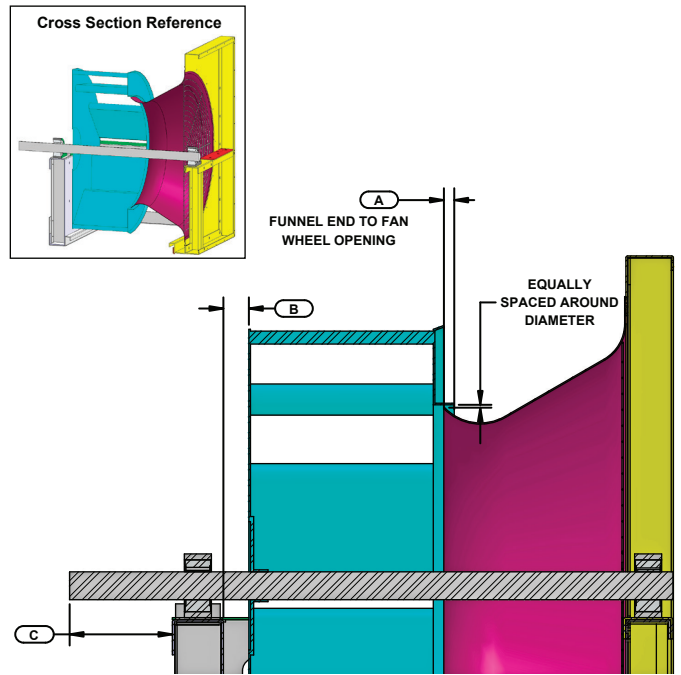
**Figure 66: Wheel-to-Inlet Funnel Relationship—  
13 to 36 Belt-Drive Plenum Fans**



**Table 8: Wheel-to-Inlet Funnel Relationship—  
13 to 36 Belt-Drive Plenum Fan**

Wheel-Funnel Parameters			
Size	A	B	C
13	0.25	0.91	3.50
15	0.25	0.91	3.50
16	0.25	0.91	3.50
18	0.38	0.86	3.88
20	0.42	1.11	3.88
22	0.45	1.11	3.88
24	0.51	1.11	3.88
27	0.55	1.36	4.50
30	0.62	1.36	4.50
33	0.55	1.50	5.00
36	0.63	1.50	5.00

**Figure 67: Wheel-to-Inlet Funnel Relationship—  
40 to 60 Belt-Drive Plenum Fans**

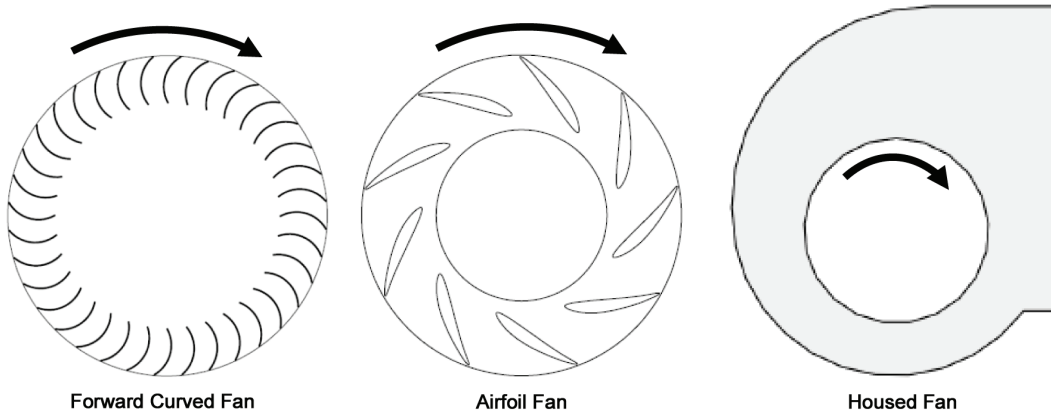


**Table 9: Wheel-to-Inlet Funnel Relationship—  
40 to 60 Belt-Drive Plenum Fan**

Wheel-Funnel Parameters			
Size	A	B	C
40	0.82	2.00	4.88
44	0.91	2.25	5.50
49	1.00	2.50	5.50
54	1.10	2.50	5.50
60	1.23	3.00	5.50

Setscrews on MPQ fan wheels must be installed using a calibrated torque wrench to the value listed below,  $\pm 5\%$ . The fasteners must be periodically checked to satisfy agency requirements for components on rotating machinery.

Figure 68: Fan Wheel Rotation



Fan wheel should rotate as shown

Table 10: Wheel-to-Inlet Funnel Relationship—  
Direct-Drive Fans Only Class II fans

Fan Size	Overlap (in.)
11	0.25
12	0.25
15	0.25
16	0.38
18	0.38
20	0.41
22	0.45
24	0.50
27	0.55
30	0.61
33	0.67
36	0.75
40	0.82
44	0.91

Table 11: Wheel-to-Inlet Funnel Relationship—  
Direct-Drive Class III fans

Fan Size	Overlap (in.)
13	0.12
15	0.19
16	0.25
18	0.31
20	0.38
22	0.44
24	0.50
27	0.56
30	0.62
33	0.75
36	0.81
40	0.88
44	0.94
49	1.0
54	1.06
60	1.12

Table 12: Setscrew Torque Specifications—  
Class II Plenum

Fan Size	Setscrew Size	Torque (ft.-lb)	
		Aluminum	Steel
11/12/13	3/8	19.2	N/A
15	3/8	19.2	N/A
16	3/8	19.2	N/A
18	3/8	19.2	N/A
20	3/8	19.2	N/A
22	3/8	19.2	N/A
24	3/8	19.2	N/A
27	3/8	19.2	22
30	1/2	41.7	55
33	1/2	41.7	55
36	1/2	41.7	55
40	1/2	41.7	55
44	1/2	41.7	55
49	1/2	41.7	55
54	1/2	41.7	55
60	3/4	115	150

Table 13: Bearing Collar and Wheel Hub Set Screw Torque  
(All Fans Except Class II Plenum Fans)

Set Screw Diameter (in)	Minimum torque ft/lbs (kg/m)
1/4	5.5 (0.76)
1/16	10.5 (1.45)
3/8	19.0 (2.63)
7/16	29.0 (4.01)
1/2	42.0 (5.81)
5/8	92.0 (12.72)

# Daikin Applied Fan Array

**⚠ WARNING**

Closing the damper on an operational fan could send the fan into surge that could produce fans stall, excessive vibration, unit damage, or personnel injury.

The Daikin Applied Fan Array is available with optional, factory mounted VFDs. See OM manuals OM 1190 and 1191 for details on the Daikin Applied supplied VFD.

Care should be taken when programming and synchronizing the drives in the Daikin Applied Fan Array such that all fans turn at the same speed. Fans running at unequal speeds can produce vibration and could stall a fan. Definition of fan numbering is given in [Figure 69](#).

The Daikin Applied Fan Array is standard with a manual block off plate. The unit will ship with one block off plate that will come installed on fan 1A. This block off plate is to be removed before unit operation and stored outside of the air tunnel. In the event of a lost fan motor, the block off plate is installed on the non-functional fan to prevent air re-circulation. This is designed to be a temporary measure until this fan and/or motor is replaced. After fan and/or motor replacement the block off plate is to be removed and stored outside of the air tunnel.

The Daikin Applied Fan Array has an optional gravity actuated block off damper. These dampers are equipped with counter weights.

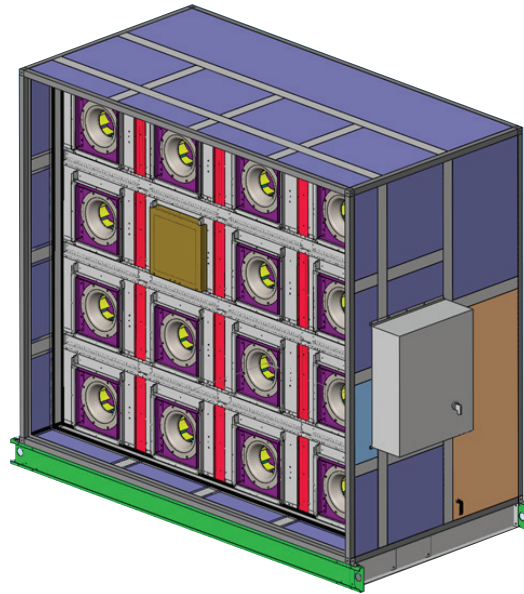
The Daikin Applied Fan Array has an optional actuated block off damper. These dampers are designed to prevent air recirculation in the event of a lost fan. Care should be taken that the damper actuator only be given a close signal if the fan is not operational (motor burnout for example).

The Daikin Applied Fan Array can be equipped with a fan blank off plate. See [Figure 70](#) with a block off plate mounted to fan 3C. If the unit is ordered with the manual block off plate, it will be installed to fan 1A. This plate has to be removed before start up.

**Figure 69: Daikin Applied Fan Array Configuration**

6D	5D	4D	3D	2D	1D
6C	5C	4C	3C	2C	1C
6B	5B	4B	3B	2B	1B
6A	5A	4A	3A	2A	1A
Viewed from Fan Inlet End					

**Figure 70: Fan Array with Block Off Plate**



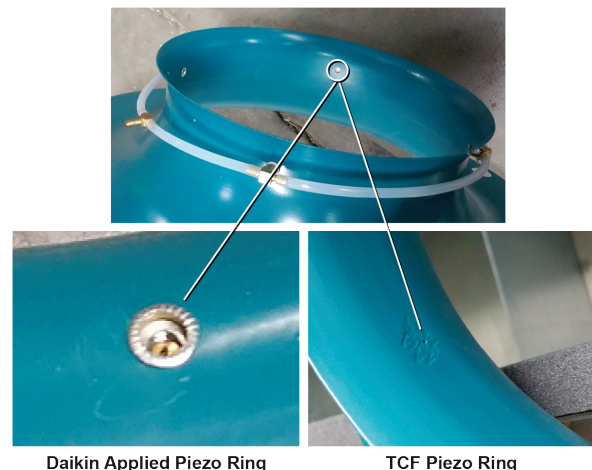
## Optional Piezometer Ring Airflow Measurement Device

Piezometer rings are available as an option on direct drive plenum fans to measure airflow through the fan. The device consists of a piezometer ring mounted in the throat of the funnel and a static pressure tap mounted near the inlet of the funnel. The pressure drop is measured from the tap located near the inlet of the funnel to the piezometer ring in the throat. The inlet tap is connected to the high-pressure side of the transducer and the piezometer ring is connected to the low-pressure side.

See the equations and factors required to calculate flow using the piezometer ring.

**NOTE:** There are two manufacturer options for the piezometer ring. Care should be taken to ensure that the appropriate coefficients are used, otherwise airflow measurement may be incorrect. Reference [Figure 71](#) to determine which piezometer ring you have.

**Figure 71: Determining the Manufacturer**



Daikin Applied Piezo Ring

TCF Piezo Ring

**Non-Standard Density Method**

The following equation is used to measure the flow for non-standard density:

$$ACFM = C1 \times A \times \sqrt{(\Delta P/\rho)}$$

where: A = Inlet funnel throat area (square feet) - from [Table 15](#) and [Table 17](#)

$\Delta P$  = The differential in static pressure from the piezometer ring and the inlet pressure tap (inches w.g.)

$\rho$  = Air density (pounds mass/cubic foot)

C1 = Value from [Table 14](#) and [Table 16](#)

**Standard Density Method**

The equation can be simplified by assuming standard density and assuming funnel dimensions match the drawing dimensions. [Table 15](#) and [Table 17](#) show the factor (F) for each fan size and type. The equation then becomes the following:

For standard air ( $\rho = 0.075 \text{ lb/ft}^3$ ):

$$ACFM = F \times \sqrt{(\Delta P)}$$

where: F = factor from [Table 15](#) and [Table 17](#)

$\Delta P$  = The differential in static pressure from the piezometer ring and the front pressure tap (inches w.g.)

**Table 14: DDPL Factors For Free and Ducted Inlet — Non Standard Density Method, TCF Piezo Ring**

Product	C1 Free Inlet	C1 Ducted Inlet
DDPL Size 11-16	753.06	794.06
DDPL Size 18-44	692.03	740.14

**Table 15: DDPL Factors For Free and Ducted Inlet — Standard Density Method, TCF Piezo Ring**

DDPL Size	Free Inlet F	Ducted Inlet F	Area A	Wheel Diameter
11 and 12	944.92	996.36	0.344	12.40
15	1206.40	1272.08	0.439	14.00
16	1518.58	1601.26	0.552	15.75
18	1821.92	1948.58	0.721	18.25
20	2185.80	2337.76	0.865	20.00
22	2713.93	2902.60	1.074	22.25
24	3285.02	3513.39	1.300	24.50
27	3997.61	4275.53	1.582	27.00
30	4945.21	5289.01	1.957	30.00
33	5968.62	6383.56	2.362	33.00
36	7290.21	7797.03	2.885	36.50
40	8869.55	9486.16	3.510	40.25
44	10827.92	11580.68	4.285	44.50

**Table 16: DDPL Factors for Free and Ducted Inlet – Non-Standard Density Method, Daikin Applied Piezo Ring**

DDPL Size	C1 Free Inlet	C1 Ducted Inlet
12	783.66	792.43
15	767.48	763.62
16	732.77	757.40
18	612.29	619.65
20	653.83	652.65
22	674.42	673.16
24	679.53	681.34
27	656.57	660.15
30	691.07	692.12
33	675.26	677.89
36	675.83	676.67
40	699.51	694.22
44	681.07	681.01

**Table 17: DDPL Factors for Free and Ducted Inlet – Standard Density Method, Daikin Applied Piezo Ring**

DDPL Size	Free Inlet F	Ducted Inlet F	Area A	Wheel Diameter
12	1004.66	1016.46	0.344	12.40
15	1261.99	1260.20	0.439	14.00
16	1526.96	1572.35	0.552	15.75
18	1675.69	1672.77	0.721	18.25
20	2117.33	2110.61	0.865	20.00
22	2710.75	2693.35	1.074	22.25
24	3312.67	3319.41	1.300	24.50
27	3901.60	3929.94	1.582	27.00
30	5017.64	5033.71	1.957	30.00
33	5942.72	5979.46	2.362	33.00
36	7274.52	7316.07	2.885	36.50
40	9179.91	9089.14	3.513	40.25
44	10891.71	10880.24	4.285	44.50

**Optional Transducer for Piezometer Rings**

A transducer is available for Piezometer rings. Factory mounting locations for the fan transducer is shown in [Figure 72](#) for direct-drive plenum fans. [Figure 73](#) shows the installation for fan array. Wiring for the transducer is field-supplied and installed.

Figure 72: Direct-drive Plenum Fan Installation

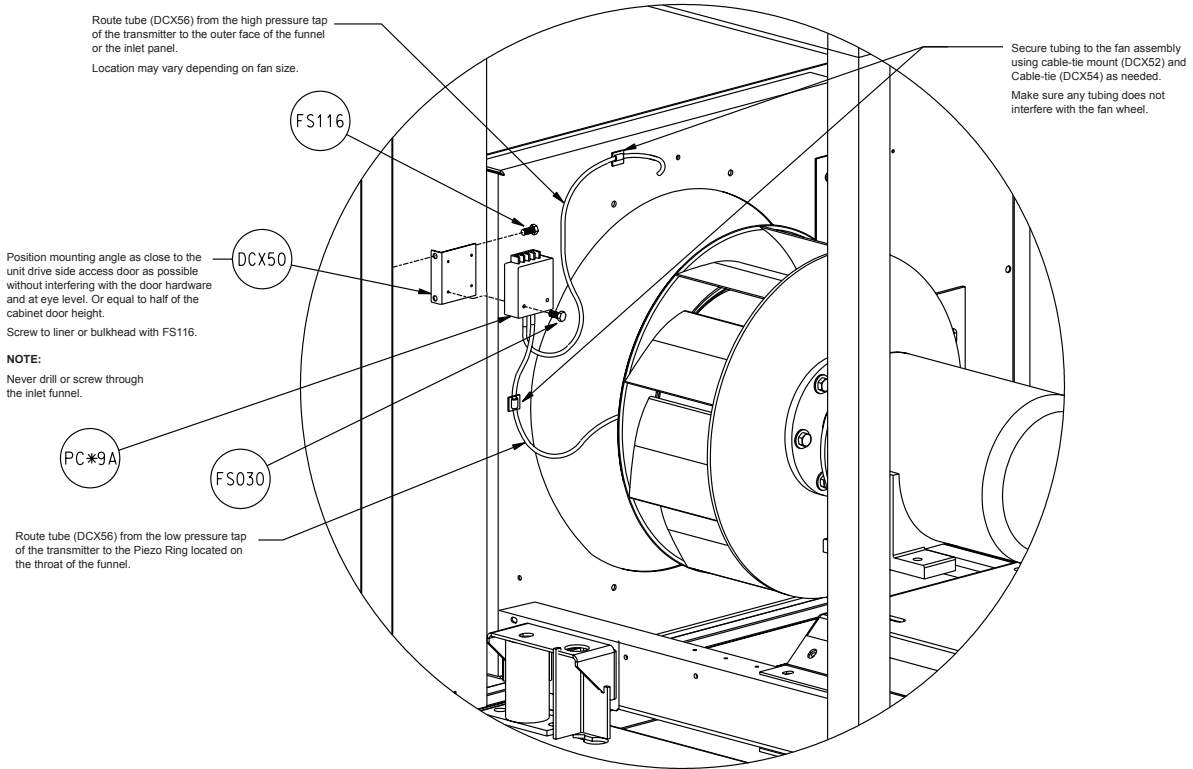
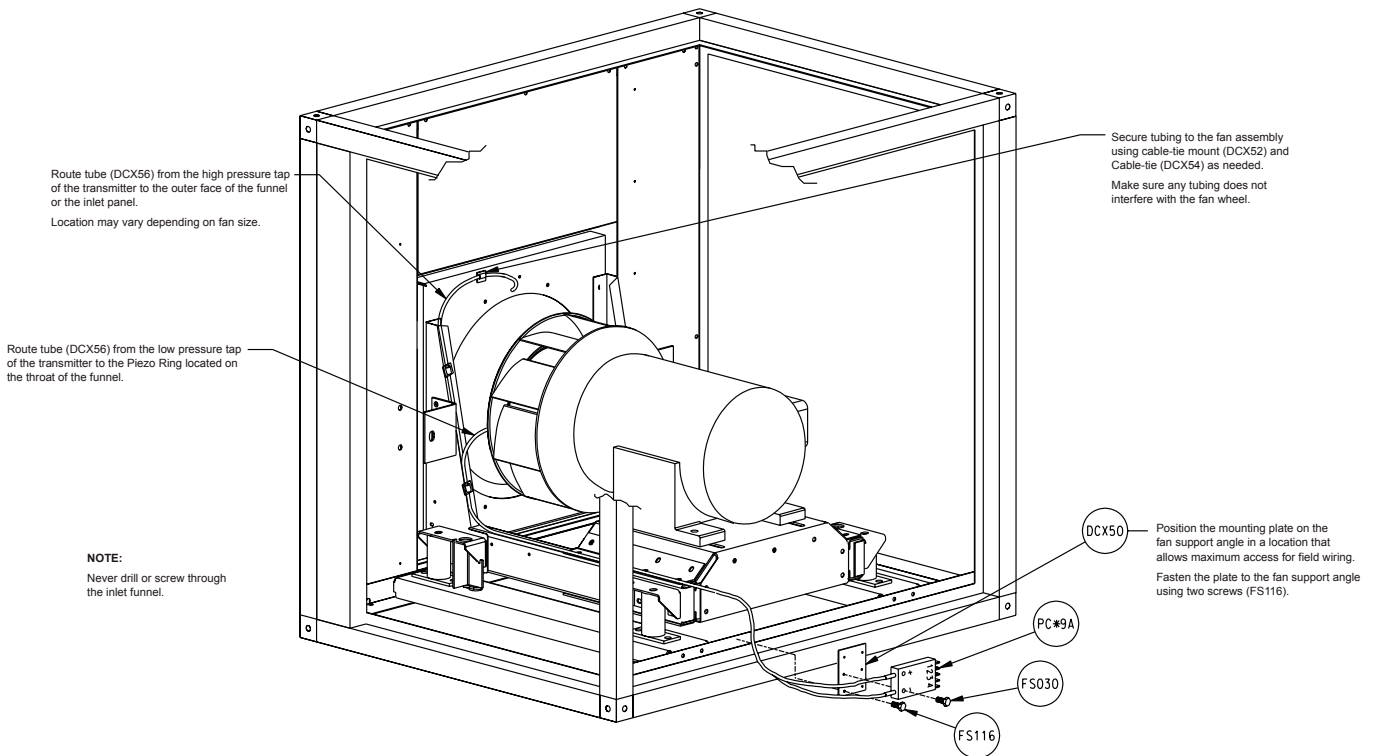


Figure 73: Fan Array Installation



# Daikin Applied EC Fan Array

The Daikin Applied EC Fan Array is made of an impeller, EC motor, and inverter. It is installed as an assembly, and in the event of failure, the entire assembly must be replaced. Bearings are permanently sealed and lubricated, so no periodic greasing is necessary.

A minimum 24" access section is recommended downstream of the ECM fan array section to gain access to the fans. If an access section is not selected downstream of the fan array, there will be very limited access to the fans for [service/replacement](#).

There are three control offerings; none, manual/auto, and digital controls. For manual/auto, an HOA switch and potentiometer are included. The entire array is controlled via a 0-10V signal. Control signal is wired to points 3 and 4 on the Daikin Applied low voltage terminal strip. There are two other points for the EC Fan Array: fan array enable and disable are points 1 and 2, and fan array fault are points 5 and 6. If any fan in the fan array faults, the contact connection between 5 and 6 will open.

**NOTE:** To DISABLE the array, connect points 1 and 2 together. The array defaults to ENABLE with nothing connected to points 1 and 2.

The digital controls option is a DDC controller allowing for equipment configuration, monitoring, and troubleshooting. The controller is either factory installed on the unit or remote mounted. Reference [OM 1329](#) for configuration and operation information.

The Daikin Applied EC Fan Array has an optional gravity actuated block off damper. These dampers are equipped with counter weights.

The EC Fan Array has an option for a block off plate that can be ordered as a parts kit from the Daikin Applied Parts group. A minimum 24" access section is recommended upstream of the ECM fan array section to install block-off plate (see "[Block-Off Plate Installation](#)" on page 41).

## Remote Mounted Panel

The control panel can be ordered for remote mounting. For remote mounted panels, the control wiring for the individual fans will be provided; however, the control wiring to connect the final fan to the control panel and all of the power wiring must be field-provided. If control panel is too heavy to be mounted on unit then it will be shipped separately and must be remote mounted.

30 foot long high voltage harnesses may be ordered through the Daikin Applied Parts Group using part number 910232406. One high voltage harness is required per fan.

If wiring harnesses are not purchased through Daikin Applied, follow the below instructions to install the wiring.

1. High Voltage Power Wiring:
  - a. Remove the plate on the back of each fan.
  - b. Remove the provided high voltage plug and wiring shown in [Figure 74](#).
  - c. Cut, strip, and connect wiring directly to each

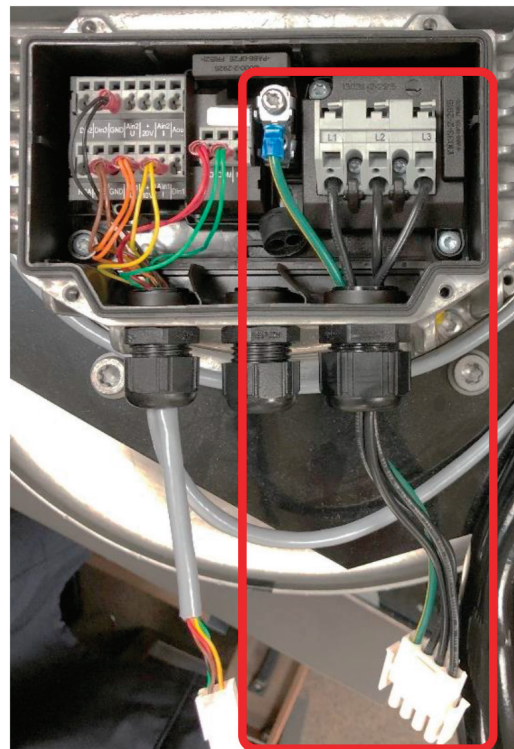
motor terminal shown in [Figure 74](#), paying attention to the correct phasing. Reference the wiring schematic provided with unit or [page 42 through page 44](#). Wiring to be in accordance with NEC.

- d. Cut, strip, and connect the other end of the wiring to the Manual Motor Protector (MMP) in the control panel, paying attention to phasing. Reference the wiring schematic provided with unit or [page 42 through page 44](#).

**NOTE:** [Figure 75](#) shows a single fan control box. There will be 1 MMP per fan in the array to connect each fan to.

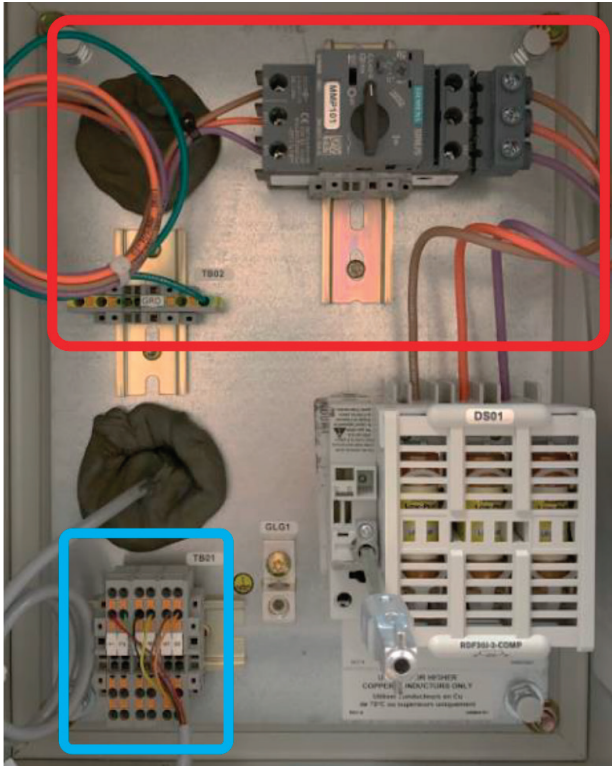
2. Low Voltage Control Wiring:
  - a. Verify same plugs and terminals are used for all control options and fan type.
  - b. 22-gauge Cat5 wiring, a standard 6-circuit female Molex plug (39-01-2061), and six Molex crimp terminals (39-00-0040) are required ([Figure 76](#)). The finished harness will have a plug on one end and stripped wire on the other end.
  - c. Attach the wiring to the Molex crimp terminal and insert into the Molex plug. See [Figure 77](#) for correct crimp terminal locations; reference schematic shipped with unit for wiring numbers (out of ECM01). Connect to the male plug that is on the last fan in the array.
  - d. Insert the stripped wire end into the terminals in the control panel, following the wiring diagram shipped with unit or [page 42 through page 44](#). Terminals are shown in [Figure 77](#).

**Figure 74: Fan - High Voltage Wiring**

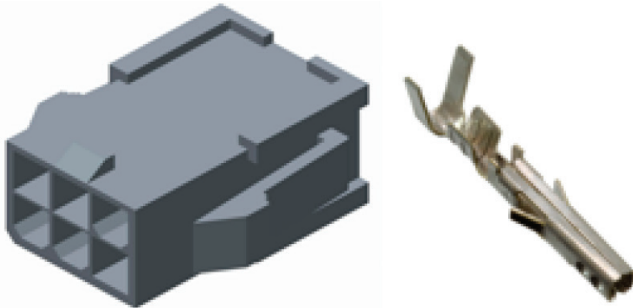




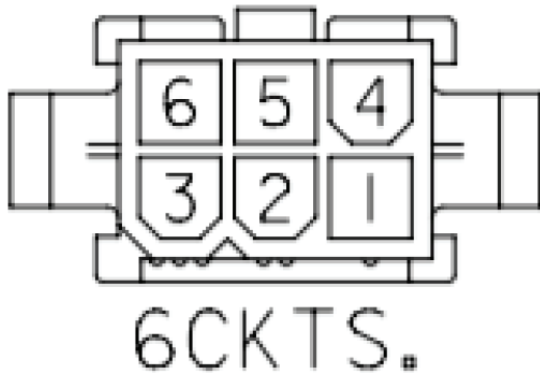
**Figure 75: Single Fan Control Panel - High Voltage Wiring (in red); Low Voltage Wiring (in blue)**



**Figure 76: Required Molex plug and crimp terminals**



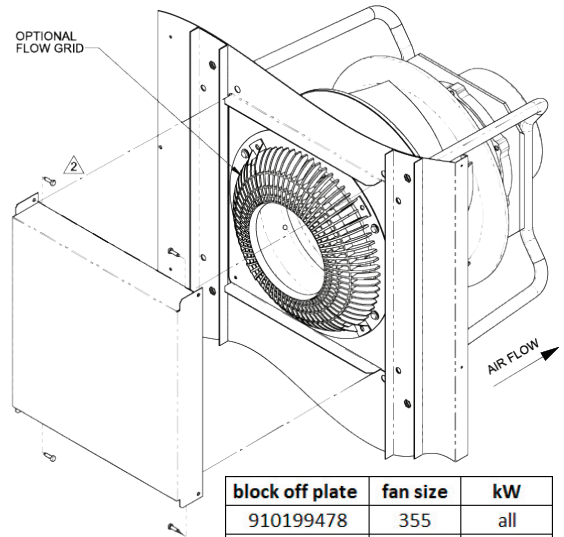
**Figure 77: Molex plug crimp terminal locations**



**Figure 78: EC Fan Array**



**Figure 79: Block-Off Plate Installation**



block off plate	fan size	kW
910199478	355	all
910199479	450	all
910311272	560	all
910311272	630	5.9 ; 6.3
910311273	630	7.1 ; 9.8

NOTES:  
 1) INSTALL BACK-DRAFT PANEL AS SHOWN OVER NON-FUNCTIONING FAN  
 2) SECURE USING (4) SELF DRILL/TAPPING SCREWS

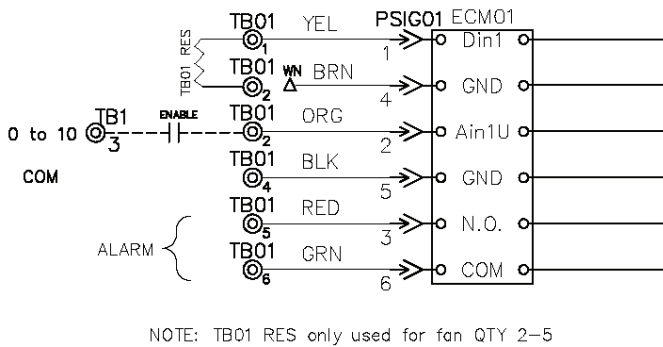
**Figure 80: EBM Gen 2 Motor**



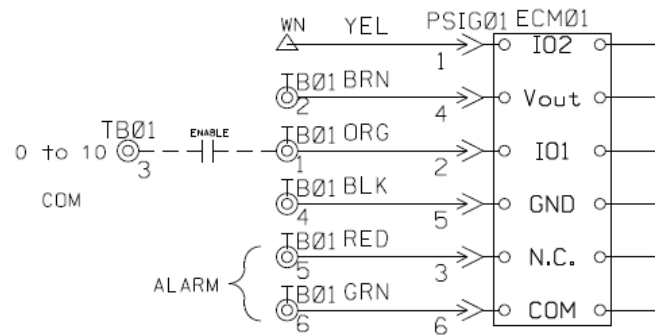
**Figure 83: EBM Gen 3 Motor**



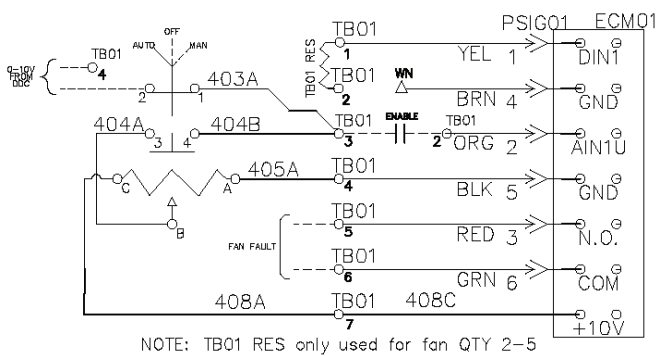
**Figure 81: EBM Gen 2 Motor - Control Wiring with No Controls**



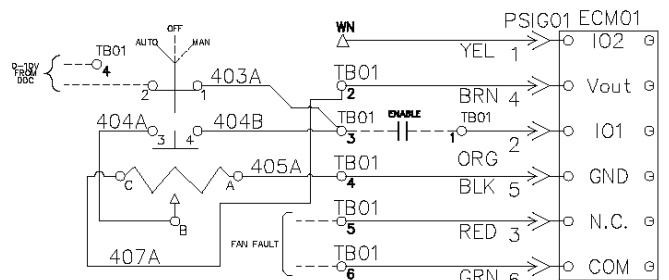
**Figure 84: EBM Gen 3 Motor - Control Wiring with No Controls**



**Figure 82: EBM Gen 2 Motor - Control Wiring with Manual/ Auto (Basic) Controls**



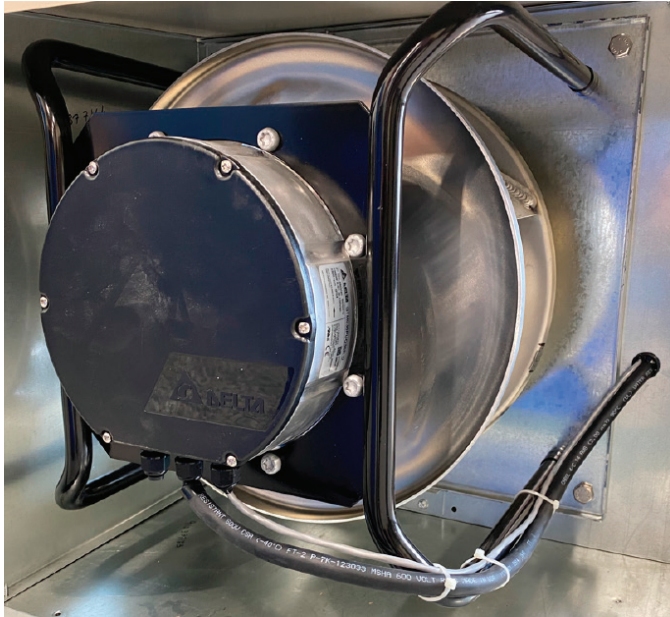
**Figure 85: EBM Gen 3 Motor - Control Wiring with Manual/ Auto (Basic) Controls**



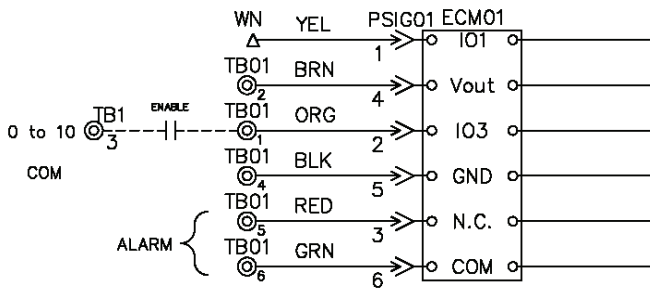
**NOTE:** For EC Fan DDC controller information and wiring, reference ED 19123.

**NOTE:** For EC Fan DDC controller information and wiring, reference ED 19123.

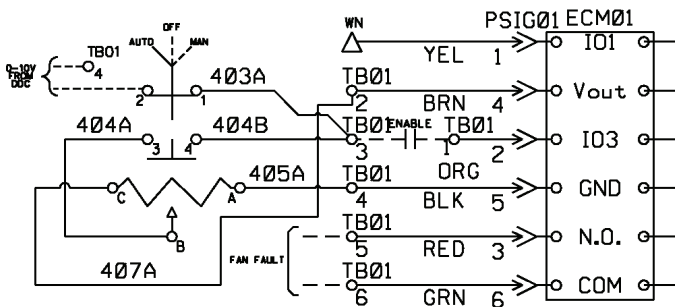
**Figure 86: Delta Motor**



**Figure 87: Delta Motor - Control Wiring with No Controls**

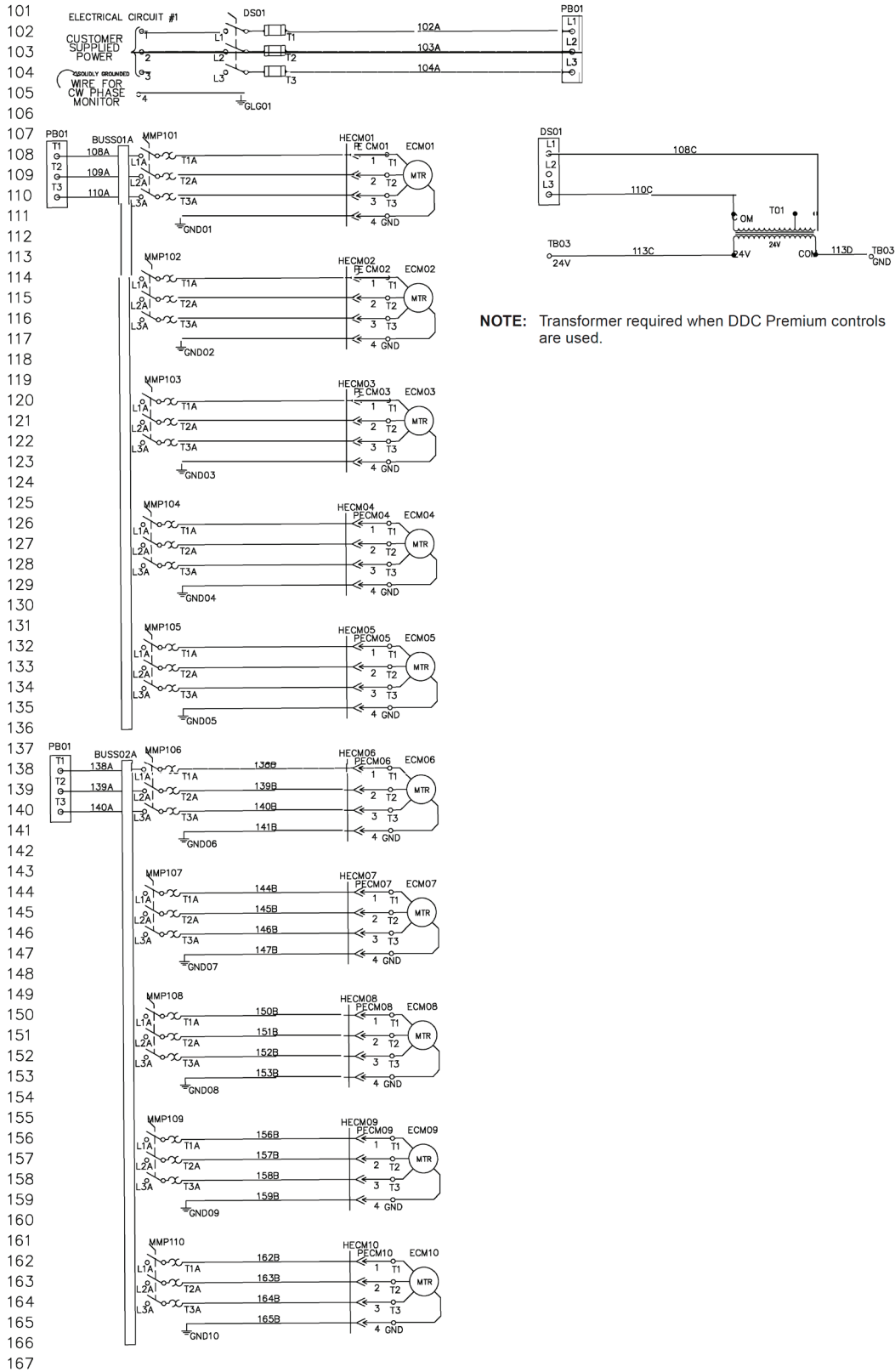


**Figure 88: Delta Motor - Control Wiring with Manual/Auto (Basic) Controls**



**NOTE:** For EC Fan DDC controller information and wiring, reference ED 19123.

Figure 89: Line Voltage Wiring - All Fans



## Optional Piezometer Point Airflow Measurement Device

A Piezometer point is an option with EC fans to measure airflow through the fan. The device consists of a piezometer point mounted in the throat of the funnel and a static pressure tap mounted near the inlet of the funnel. The pressure drop is measured from the tap located near the inlet of the funnel to the piezometer point in the throat. The inlet tap is connected to the high-pressure side of the transducer and the piezometer point is connected to the low-pressure side.

A transducer is always factory supplied when the Piezometer Option is selected with an EC Fan. [Figure 90](#) shows the installation for EC fans.

See the equations and factors required to calculate flow using the piezometer point:

### Non-Standard Density Method

The following equation is used to measure the flow for non-standard density:

$$ACFM = C1 \times A \times \sqrt{(\Delta P/\rho)}$$

where: A = Inlet funnel throat area (square feet) - from [Table 19](#)

$\Delta P$  = The differential in static pressure from the piezometer ring and the inlet pressure tap (inches w.g.)

$\rho$  = Air density (pounds mass/cubic foot)

C1 = Value from [Table 18](#)

### Standard Density Method

The equation can be simplified by assuming standard density and assuming funnel dimensions match the drawing dimensions. [Table 18](#) shows the factor (F) for each fan size and type. The equation then becomes the following:

For standard air ( $\rho = 0.075 \text{ lb/ft}^3$ ):

$$ACFM = F \times \sqrt{(\Delta P)}$$

where: F = factor from [Table 19](#)

$\Delta P$  = The differential in static pressure from the piezometer ring and the front pressure tap (inches w.g.)

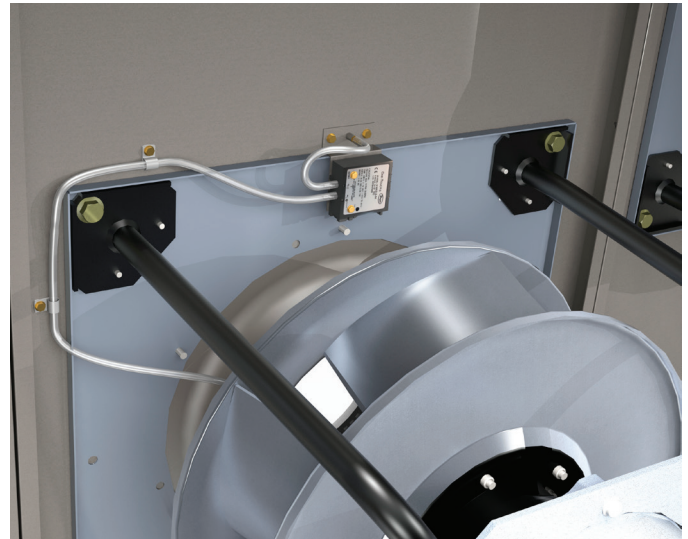
**Table 18: ECM Factors for Free and Ducted Inlet — Non-Standard Density Method**

ECM Size	C1 Free Inlet	C1 Ducted Inlet
355	774.47	774.47
450	783.31	783.31
560	658.54	658.54
630	666.68	666.68
355D	802.05	802.05
450D	783.31	783.31

**Table 19: ECM Factors for Free and Ducted Inlet — Standard Density Method**

ECM Size	Free Inlet F	Ducted Inlet F	Area A
355	1372.74	1372.74	0.485
450	2226.07	2226.07	0.778
560	3224.71	3224.71	1.341
630	4058.68	4058.68	1.667
355D	1459.58	1459.58	0.498
450D	2283.43	2283.43	0.798

**Figure 90: Piezometer Transducer**



## Fan Operating Limits

Do not exceed the operating limits in [Table 20](#) through [Table 24](#). A fan wheel operated beyond the rpm and temperature limits shown can suffer permanent distortion or fracture. The resulting unbalance can cause severe unit vibration.

**Table 20: Fan Operating Limits—Unit Sizes 003 to 035**

Forward Curved—Housed										Airfoil—Housed						
Diameter	9×4	9×7	9×9	10.62	12.62	15	18	20	22.25	24.50	13.22	14.56	16.19	19.69	21.56	24.00
Max. RPM Class I	N/A	2189	2223	1934	1614	1328	1155	1050	944	858	3000	3000	2300	2000	1700	1500
Max. RPM Class II	2244	2854	2896	2518	2091	1725	1450	1200	1030	910	4335	3918	3457	2858	2427	2255

**Table 21: Fan Operating Limits—Unit Sizes 040–090**

Forward Curved—Housed							Airfoil—Housed							
Diameter	20	22.38	25	27.62	30.25	33	36	20	22.25	24.5	27	30	33	36.5
Max. RPM Class I	1010	930	790	690	650	600	560	2077	1875	1691	1479	1328	1209	1073
Max. RPM Class II	1281	1178	1011	910	835	763	715	2703	2413	2199	1928	1730	1579	1401

**Table 22: Fan Operating Limits—Belt-Drive Plenum Fans**

Belt-Drive Plenum fans																
Size	13	15	16	18	20	22	24	27	30	33	36	40	44	49	54	60
Max. RPM Class II	3909	3468	2820	2930	2674	2403	2183	1860	1783	1620	1465	1329	1202	1091	986	891
Max. RPM Class III	4000	4000	3887	3735	3409	3065	2780	2423	2182	1984	1759	1598	1447	1314	1178	1071

**Table 23: Fan Operating Limits—Direct-Drive Plenum Fans**

Direct-Drive Plenum Fans																		
Size	11	12	13	15	16	18	20	22	24	27	30	33	36	40	44	49	54	60
Max. RPM Class II	4000	4000	—	3909	3650	3650	2674	2403	2183	1981	1783	1620	1465	1329	1202	—	—	—
Max. RPM Class III	—	—	4000	4000	3887	3735	3409	3065	2780	2423	2182	1984	1759	1598	1447	1314	1178	1071

**Table 24: Fan Operating Limits—Twin Fans**

Twin Fans												
Diameter	9×9		10.62		12.62		15		18.12		20	
Max. RPM	2575		2400		2000		1700		1400		1200	
Max. HP	10		15		15		30		40		40	

## Fan Vibration Levels

Each unit as shipped is trim balanced to operate smoothly. To provide satisfactory operation after shipping and installation, use the accepted industry guidelines for field balancing fans. See [Table 25](#).

**Table 25: Vibration Levels**

Fan Speed (RPM)	Vibration
800 or less	5 mils maximum displacement
801 or greater	0.20 in/sec. maximum velocity

**Note:**  
Excessive vibration from any cause contributes to premature fan and motor bearing failure. Monitor overall vibration levels every six months of operation. An increase in levels is an indication of potential trouble.

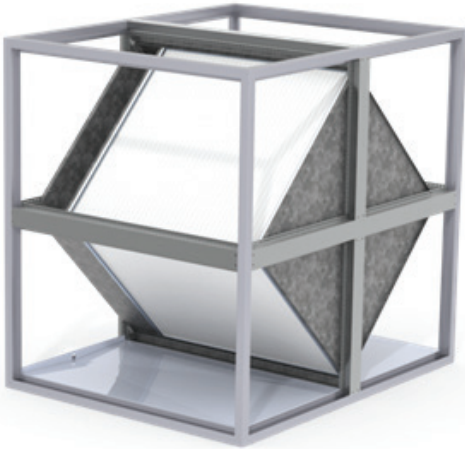
## Vibration Causes

1. Wheel imbalance.
  - a. Dirt or debris on wheel blades.
  - b. Loose set screws in wheel hub or bearing-to-shaft.
  - c. Wheel distorted from overspeed.
2. Bent shaft.
3. Drive faulty.
  - a. Variable pitch sheaves—axial and radial runout of flanges; uneven groove spacing; out of balance. Also similar faults in driven sheave.
  - b. Bad V-belts; lumpy, or mismatched; belt tension too tight or too loose.
4. Bad bearings, loose bearing hold-down bolts.
5. Motor imbalance.
6. Fan section not supported evenly on foundation.

## Fixed Plate Exchanger

Your Daikin Applied fixed plate exchanger is delivered completely assembled and ready to run. The core is built to provide many years of trouble-free service with minimal maintenance following proper installation and commissioning.

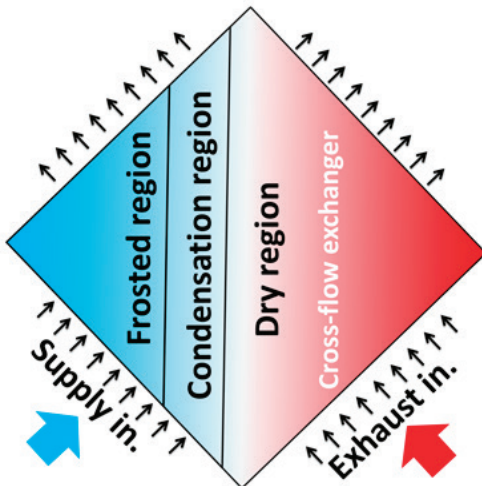
*Figure 91: Fixed Plate Exchanger with Outdoor Air Bypass*



## Frost Protection

During extreme cold winter conditions, the bypass is opened on the outdoor air side of the core. This minimizes the cold air across the core, allowing the exhaust air to warm the exchanger and prevent the accumulation of frost build-up on the component.

*Figure 92: Frost Region*



## Economizer Mode

When the outside air enthalpy is less than the required supply air during cooling, outside air and/or exhaust air control dampers can be provided within the fixed plate section to reduce required mechanical cooling. This is available with the enthalpy CORE fixed plate exchanger.

## Mixed-Air System

To provide a mix of outdoor air and return air to the supply airstream, a recirculation control damper can be provided. This is available with the enthalpy CORE fixed plate exchanger.

## CORE® Enthalpy Fixed Plate Exchanger

### Storage

The enthalpy core must be stored away from direct sun light and strong UV rays. If stored for an extended period of time, it is recommended to have the exchanger's faces covered to avoid dust deposition on the membrane surface or be washed with tap water.

### Maintenance

The heat exchanger and damper actuators can be accessed from the four removable panels located on both sides of the heat exchanger section. Outside air, exhaust air, and bypass air damper actuators may be accessed more easily from the opposite drive side.

It is important to wash the CORE at least once per year, using tap water and mild detergent such as Dawn®, Palmolive® or equivalent dish soap.

- Do not use a high-pressure water source
- Wash the core in place. Ensure adequate drainage via the drip pan is available for waste water
- If the CORE is heavily soiled, prepare a solution of less than 1:100 parts water to dish soap. Otherwise, clean water will suffice
- Pour solution (or clean water) through the core, both Supply and Exhaust paths, ensuring exposure of all layers
- Rinse with clean tap water until no bubbles appear in the exiting water
- Allow the core to dry until no water is dripping out

While cleaning other adjacent components in the HVAC system, it is possible for the core to come in contact with harsher detergents. The following is a list of coil cleaners and all-purpose cleaners that have been tested with the CORE exchanger, and what the recommendation is for exposure. Generally, contact with any coil cleaning product is not recommended, and specifically hydroxide-based cleaners should be avoided. If contact does occur, the core should be rinsed immediately as it may void the CORE warranty.

**Table 26: Cleaner Recommendations**

Cleaner	Recommendation
Viper Expanding Foam	OK
CalSpray–nu-Brite	Avoid Contact
CalSpray–evap foam	OK
HD CalClean 1:40	OK
HD CalClean 1:5	Avoid Contact
Fantastik w/ Bleach	Avoid Contact
Fantastik Original	Avoid Contact

## Sensible Fixed Plate Heat Exchanger

### Maintenance

The sensible fixed plate heat exchangers are designed to prevent particles from coming into contact with the heat transfer surfaces. The air channels in these exchangers have been designed so that most particles contained in the air will pass straight through them. Viscous substances and those that may condense on plate surfaces present the highest risk of fouling the exchanger.

Experience has shown that the build-up of dirt in a heat exchanger usually occurs only in the first few inches inside the upstream face of the exchanger. In this case, cleaning can be accomplished with a brush or hot water and, if needed, a mild detergent or coil cleaner approved for use on aluminum. For dirtier applications, compressed air or a water hose with spray nozzle can be used. If using a water hose, keep maximum pressure below 60 PSI (typical municipal water line pressure) and direct the water stream parallel to the plates—do not use directly against the plate surfaces.

Although the plates in the aluminum heat exchangers are made of material that is up to 0.008” thick, care must be taken when mechanical means are used to remove dirt so that the plates do not deform or tear.



# Maintenance

## Periodic Maintenance

1. Check all moving parts for wear every six months.
2. Check bearing collar, sheave, and wheel hub setscrews, sheave capscrews, and bearing hold-down bolts for tightness every six months.
3. Annually check and snug all electrical connections. Inspect for signs of water damage such as corrosion and repair if necessary. Check ground conductor and connection integrity and correct if needed.

## Ball Bearing Lubrication

**CAUTION**

Bearing overheating potential. Can damage the equipment. Do not over lubricate bearings. Use only a high grade mineral grease with a 200°F safe operating temperature. See below for specific recommended lubricants.

## Motor Bearings

Supply and return fans—Supply and return fan motors should have grease added after every 2000 hours of operation. Using the following procedure, re-lubricate the bearings while the motor is warm, but not running. Use one of the greases shown in [Table 27](#).

1. Remove and clean upper and lower grease plugs.
2. Insert a grease fitting into the upper hole and add clean grease ([Table 27](#)) with a low pressure gun.
3. Run the motor for five minutes before replacing the plugs.

**NOTE:** Direct-Drive Class II fans that are supplied with TECO motors have double shielded bearings on frame sizes 140T-280T. These bearings are pre-packed with a long life grease and are not regreaseable. Larger frame size TECO motors are regreaseable and follow the same lubrication recommendations as all other motors.

**Table 27: Recommended Lubricants and Amounts for Fan Motor Bearings**

Manufacturers' Grease	NEMA Size	Amount to Add (oz.)
Texaco, Polystar or Polyrex EM (Exxon Mobile) or Rykon Premium #2 or Penzoil Pen 2 Lube	56 to 140	0.08
	140	0.15
	180	0.19
	210	0.30
	250	0.47
	280	0.61
	320	0.76
	360	0.81
	400	1.25
	440	2.12

**NOTE:** Specific greasing instructions are located on a tag attached to the motor. If special lubrication instructions are on the motor, they supersede all other instructions.

## Fan Shaft Bearings

**CAUTION**

For safety, stop rotating equipment. Add one half of the recommended amount shown in [Figure 27](#). Start bearing, and run for a few minutes. Stop bearing and add the second half of the recommended amount. A temperature rise, sometimes 30°F (1°C after lubrication is normal). Bearing should operate at temperature less than 200°F (94°C) and should not exceed 225 (107°C) for intermittent operation. For a lubrication schedule, see [Table 28](#). For applications that are not in the range of the table, contact Daikin Applied.

**CAUTION**

[Table 28](#) and [Table 29](#) state general lubrication recommendations based on our experience and are intended as suggested or starting points only. For best results, specific applications should be monitored regularly and lubrication intervals and amounts adjusted accordingly.

Any good quality lithium or lithium complex base grease, using mineral oil, conforming to NLGI grade 2 consistency, and an oil viscosity of 455-1135 SUS at 100°F (100-200 cSt at 40°C) may be used for re-lubrication.

Compatibility of grease is critical. Lubricatable bearings are supplied with grease fittings or zerks for ease of lubrication with hand or automatic grease guns. Always wipe the fitting and grease nozzle clean.

**Table 28: Lubrication Intervals**

Speed	Bearing Temperature	Cleanliness	Lubrication Intervals
(Use NLGI #2 Lithium or Lithium Complex Grease)			
100 RPM	Up to 120°F (50°C)	Clean	6 to 12 months
500 RPM	Up to 150°F (65°C)	Clean	2 to 6 months
1000 RPM	Up to 210°F (100°C)	Clean	2 weeks to 2 months
1500 RPM	Over 210°F (100°C) to 250°F (120°C)	Clean	Weekly
Above 1500 RPM	Up to 150°F (65°C)	Dirty/Wet	1 week to 1 month
Max Catalog Rating	Over 150°F (65°C) to 250°F (120°C)	Dirty/Wet	Daily to 2 weeks
	Above 250°F (120°C)		Contact Browning

Table 29: Recommended Fan Lubrication Grease Charge

Shaft Size in Inches (mm)	Weight in Ounces (grams)
1/2 to 3/4 (20)	0.03 (0.85)
7/8 to 1-3/16 (25-30)	0.10 (2.84)
1-1/4 to 1-1/2 (35-40)	0.15 (4.25)
1-11/16 to 1-15/16 (45-50)	0.20 (5.67)
2 to 2-7/16 (55-60)	0.30 (8.51)
2-1/2 to 2-15/16 (65-70)	0.50 (15.59)
3 to 3-7/16 (75-80)	0.85 (24.10)
3-1/2 to 4 (85-105)	1.50 (42.53)

### Fan Drive Adjustments

**WARNING**  
 Before servicing fans, lock out and tag out all power to the unit. Fans or belts can cause severe personal injury or death.

**WARNING**  
 Do not open the hinged access door and screw-fastened access panels while the unit is operating. Moving parts and strong suction forces can cause severe personal injury or death.

Upon completion of the air balance, replace the variable pitched motor sheave with a properly sized, fixed sheave. A matching fixed sheave provides longer belt and bearing life and minimizes vibration. Initially, it is best to have a variable pitched motor sheave for the purpose of air balancing. Once the balance is achieved, fixed sheaves maintain balancing and alignment more effectively. Replace the adjustable sheaves with fixed sheaves.

With the electrical power disconnected, locked and tagged out, measure the diameter of the V-belt outer surface where it passes around the sheave (pitch diameter). Calculate fan speed from the motor nameplate rpm.

$$\text{Fan RPM} = \text{motor RPM} \times \frac{\text{Measured diameter at motor sheave}}{\text{Measured diameter at fan sheave}}$$

### VM/VP Variable Pitch Key Type Sheaves

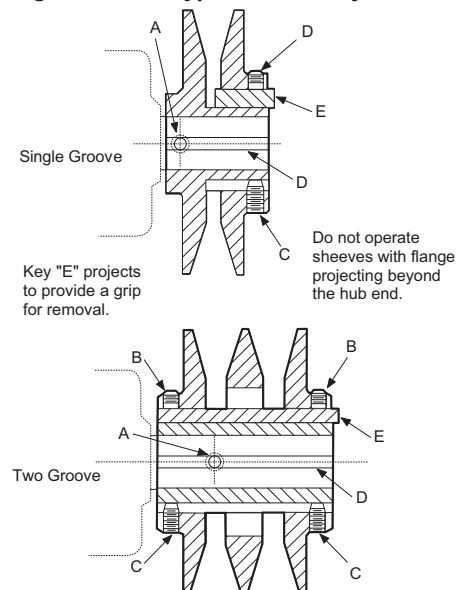
#### Mounting:

1. Mount all sheaves on the motor or driving shaft with the setscrews **A** toward the motor.
2. Verify that both driving and driven sheaves are in alignment and that shafts are parallel.
3. Fit internal key **D** between sheave and shaft and lock setscrew **A** securely in place.

#### Adjusting:

1. Loosen setscrews **B** and **C** in moving parts of sheave and pull out external key **E**. (This key projects a small amount to provide a grip for removing.)
2. To adjust sheave pitch diameter for desired speed, open moving parts by half or full turns from closed position. **Do not open more than five full turns for A belts or six full turns for B belts.**
3. Replace external key **E** and securely tighten setscrews **B** over key and setscrews **C** into keyway in fixed half of the sheave.
4. Put on belts and adjust tension. **Do not force belts over grooves.** See [Fan Drive Belt on page 54](#).
5. Make future adjustments by loosening the belt tension and increasing or decreasing the pitch diameter of the sheave by half or full turns as required. Readjust belt tension before starting drive.
6. To provide the same pitch diameter, adjust both halves of the two-groove sheaves by the same number of turns from closed position.
7. Verify that all keys are in place and that all setscrews are tight before starting drive. Check setscrews and belt tension after 24 hours service.

Figure 93: VP Type Sheave Adjustment



## LVP Variable Speed Sheaves

### Mounting:

1. Slide sheave on motor shaft so that the side of the sheave with setscrew **A** is next to the motor when setscrew **A** is in the hub or barrel of the sheave.
2. When setscrew **A** is at an angle in the center flange **B**, mount it away from the motor so that the outer locking ring and flange can be removed to get to the setscrew.
3. To remove the flange and locking ring:
  - a. Loosen setscrews **D**.
  - b. Loosen but do not remove capscrews **E**.
  - c. Remove key **F**.

**NOTE:** This key projects a small amount to provide a grip for removing.

- d. Rotate the flange counterclockwise until it disengages the threads on the sheave barrel.
4. Verify that the driving and driven sheaves are in alignment and the shafts are parallel. When aligning two-groove sheaves, allow room between the sheave and motor to access capscrews **E**.
  5. Insert key **C** between the sheave and the shaft and tighten setscrew **A** securely.
  6. If flange and locking ring have been removed, when replacing them make sure that the inner and outer flanges are open from the closed position by the same amount as the other flange. Determine this by accurately measuring the top width of the grooves.
  7. Insert key **F**.
  8. Tighten setscrews **D** and capscrews **E**.
  9. Put on belts and adjust belt tension. Do not force belts over grooves. See [Fan Drive Belt](#).
  10. Before starting the drive, ensure that all keys are in place and all setscrews and all capscrews are tight. Check and retighten all screws and retension belts after approximately 24 hours of service.

### Adjusting:

1. Slack off belt tension if belts have been installed.
2. Loosen setscrews **D**.
3. Loosen but do not remove capscrews **E**.
4. Remove key **F**.

**NOTE:** This key projects a small amount providing a grip for removing.

5. Adjust pitch diameter by opening or closing the movable flanges by half or full turns.

**NOTE:** Two-groove sheaves are supplied with both grooves set at the same pitch diameter. To provide the same pitch diameter for satisfactory operation, move both movable flanges the same number of turns. Do not open sheaves more than five turns for A belts or six turns for B belts.

6. Replace key **F**.
7. Tighten setscrews **D** and capscrews **E**
8. If belts have been installed, readjust belt tension. If belts have not been installed, install them and adjust belt tension. **Do not force belts over grooves.** See [Fan Drive Belt on page 54](#).
9. Before starting the drive, ensure that all keys are in place and all setscrews and all capscrews are tight. Check and retighten all screws and retension belts after approximately 24 hours of operation.
10. Replace variable speed sheaves for 15 hp motors and greater with a fixed pitch sheave after air balancing to maintain fan balance integrity. Fixed sheaves furnished by others.

## MVP Variable Speed Sheaves

### Mounting:

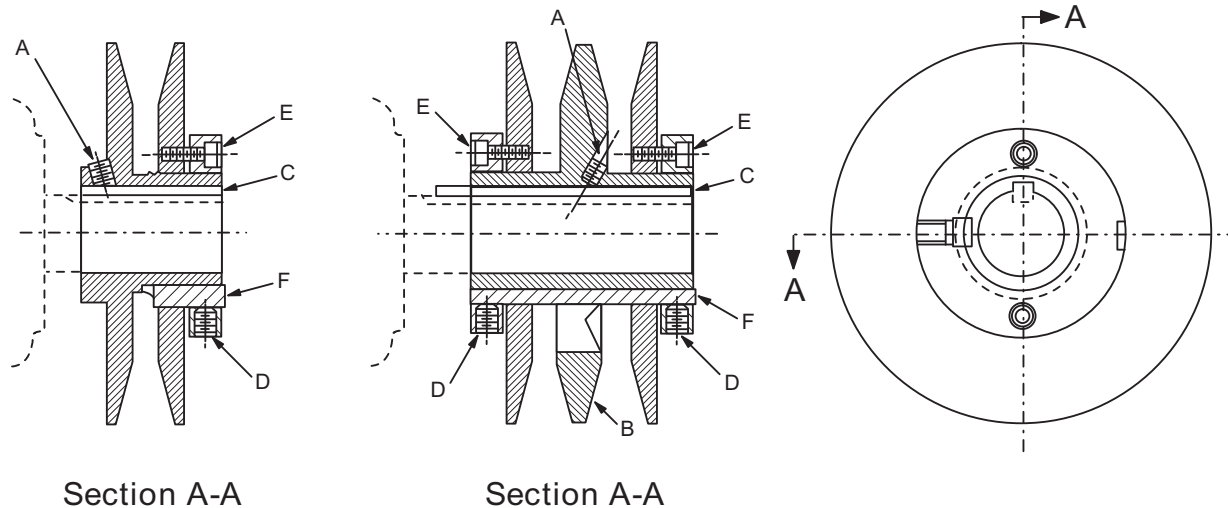
1. Verify both driving and driven sheaves are in alignment and the shafts are parallel. The centerline of the driving sheave must be in line with the centerline of the driven sheave (Figure 95).
2. Verify that all setscrews are torqued to the values shown in Table 30 before starting drive. Check setscrew torque and belt tension after 24 hours of service.

### Adjusting:

1. Adjust motor base forward to release belt tension. Remove the belts for easier adjustment.
2. Loosen, but do not remove both of the locking setscrews **A** in the outer locking ring by using a hex key or torque wrench with a hex bit.
3. Adjust sheave to desired pitch diameter by turning the outer locking ring, using a spanner wrench or drift inserted into the three holes that are located 120° apart on the ring.

4. Any pitch diameter can be obtained within the sheave range. One complete turn of the outer locking ring changes the pitch diameter 0.233".
5. Do not open sheaves more than the following
  - a. Do not open **B** sheaves more than 4-3/4 turns for the **A** belts or 6 turns for the **B** belts.
  - b. Do not open **C** sheaves more than 9-1/2 turns.
  - c. Do not open **5V** sheaves more than 6 turns.
  - d. Do not open **8V** sheaves more than 8 turns.
6. Tighten BOTH locking screws **A** in the outer locking ring before operating the drive. Use a torque wrench and tighten to the value shown in Table 30.
7. Replace belts and adjust the motor base to tension the belts properly. See Fan Drive Belt on page 54.
8. Do not loosen any screws other than the two locking screws **A** in the outer locking ring when adjusting the sheave pitch. Do not operate the drive until the locking screws have been set to the torque specifications.

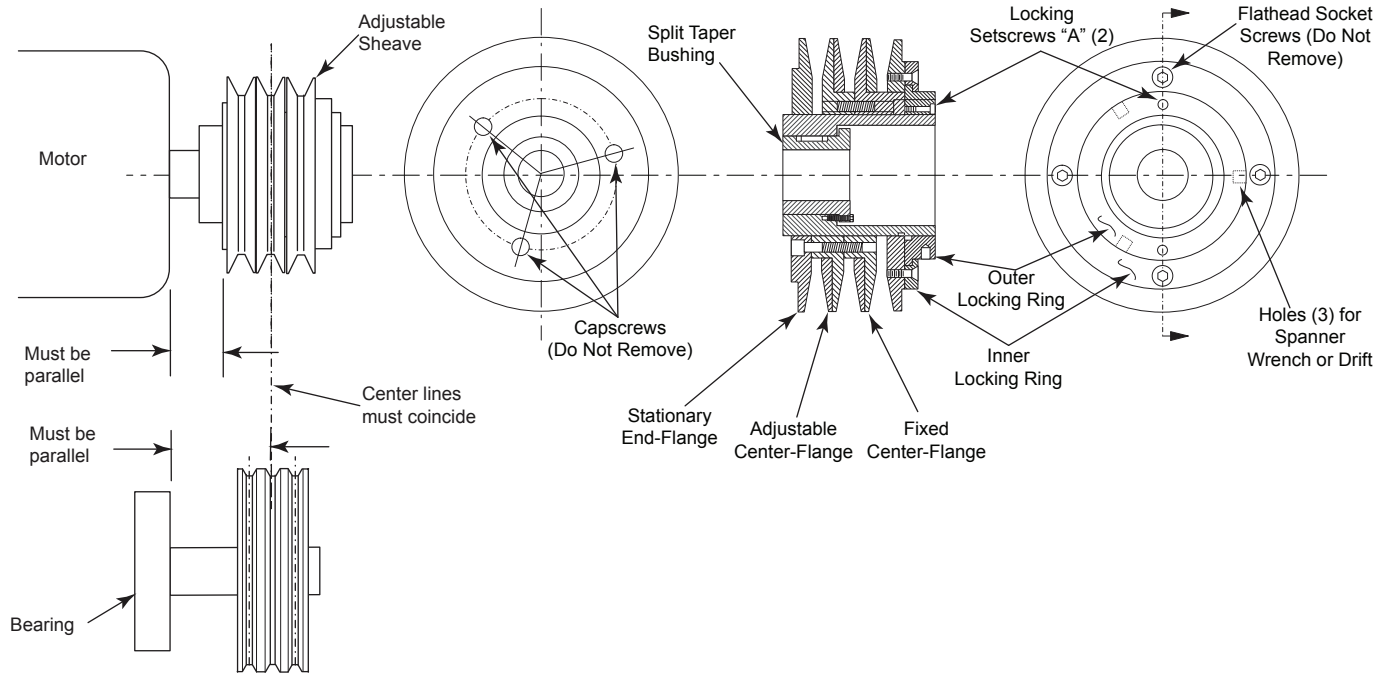
Figure 94: LVP Type Sheave Adjustment



**Table 30: Screw Torque Values**

Nominal Screw Size (dia-thds/in)	Socket Head Cap Screws		Flat Head Socket Screws	Hollow Head Set Screws Only			
	Seating Torque		Seating Torque	Lengths Equal or Greater Than Dia.		For Lengths (L) Less Than Dia.	
	(in-lbs)	(in-lbs)	(in-lbs)	Seating Torque (in-lbs)	Seating Torque (in-lbs)	Length (L) (in)	Seating Torque (in-lbs)
1/4-20NC	150	12.5	100	87	7.3	3/16	50
5/16-11NC	305	25.4	200	165	13.8	1/4	90
3/8-16NC	545	45.4	350	290	24.2	1/4, 5/16	150, 250
1/2-13NC	1300	108.3	N/A	620	51.7	N/A	N/A
5/8-11NC	N/A	N/A	N/A	1225	102.1	N/A	N/A

**Figure 95: MVP Sheave Adjustment**



## Fan Drive Belt

⚠ WARNING
Moving belt and fan can cause severe personal injury or death.
During installation and filter maintenance:
• Verify that the belt and fan guards on plenum fan units are always in place.
• Lock and tag out fans to prevent accidental start up.
• Do not enter the filter compartment until the fan is completely stopped.
• Use approved equipment for reaching filters located above normal reach. Do not step on filter frames or unit components.
• Floor surfaces must be dry and free of oil or grease.

### General Rules of Tensioning

1. The ideal tension is the lowest tension at which the belt does not slip under peak load conditions.
2. Check tension frequently during the first 24 to 48 hours of operation.
3. Over tensioning shortens belt and bearing life.
4. Keep belts free from foreign material that can cause slippage.
5. Inspect V-drive on a periodic basis. Adjust tension if the belt is slipping. Do not apply belt dressing. This can damage the belt and cause early failure.

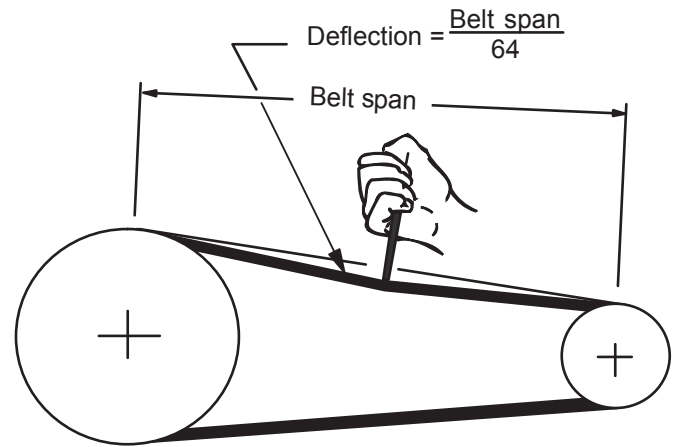
### Tension Measurement Procedure

1. Measure the belt span (Figure 96).
2. Place belt tension checker squarely on one belt at the center of the belt span. Apply force to the checker, perpendicular to the belt span, until the belt deflection equals belt span distance divided by 64. Determine the force applied while in this position.
3. Compare this force to the values in Table 31.

**Table 31: Belt Deflection Force (per Browning Specifications)**

Cross Section	Small Sheave Diameter (in)	Number of Belts (Deflection Force lbs)					
		1		2		3 +	
		Min	Max	Min	Max	Min	Max
A, AX	0.0 to 3.5	3.0	5.0	2.5	4.0	2.0	3.5
	3.6 to 4.4	3.5	5.0	3.0	4.5	2.0	4.0
	4.5 +	4.0	5.5	3.0	5.0	2.5	4.5
B, BX	0.0 to 5.4	5.5	8.0	4.5	7.0	3.5	5.5
	5.5 to 7.6	5.5	8.5	4.5	7.5	3.5	5.5
	7.7 +	6.5	9.0	5.0	8.0	4.0	6.5
5V, 5VX	0.0 to 8.5	7.0	11.0	5.5	9.0	4.0	7.0
	8.6 to 12.0	8.5	13.0	6.5	10.5	5.0	8.0
	12.1 +	10.0	15.0	7.5	11.5	5.5	9.0

**Figure 96: Drive Belt Adjustment**



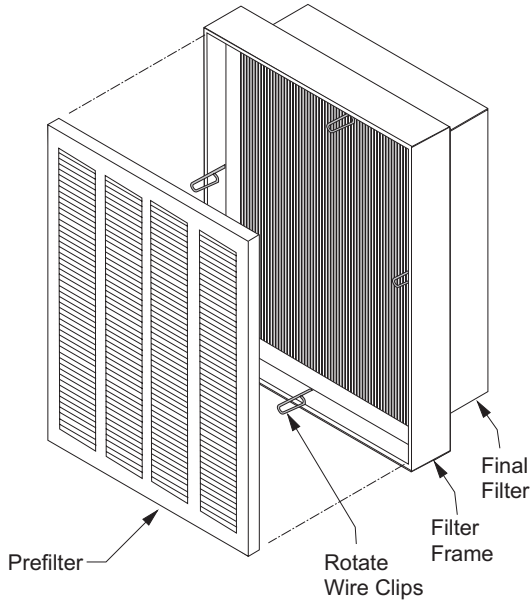
# Filters

## Front Load Filter Option

Front loaded filter options require that the filters be removed and replaced from inside the unit.

To remove filters, rotate the wire clips. This releases both the prefilter and the final filter. When installing clean filters, check to verify the filters are fully seated in the frame (Figure 97).

Figure 97: Frame and Filters with Holding Clips



## Filter Gauges

Filter gauges indicate pressure drop for installed filters. If prefilters are present, the gauge will indicate the pressure drop for both pre- and final filters.

Table 32 shows the typical filter pressure drop for clean filters at rated air flow. The tables also show a final pressure drop for front loaded filters.

Where a single filter gauge is used, the prefilters can be removed to check the pressure drop of the final filters.

Figure 98: Filter Gauge



Table 32: Filter Pressure Drops

Bag filters—DriPak 2000				
Efficiency	45%	65%	85%	95%
Rated velocity (FPM)	625	500	500	500
Initial pressure drop	0.20–0.26	0.21–0.30	0.34–0.48	0.50–0.70
Initial pressure drop	1.0	1.0	1.0	1.0
Cartridge filters—Varicel II MH, 4.25" deep				
Efficiency	65%	85%	95%	
Rated velocity (FPM)	500	500	500	
Initial pressure drop	0.43	0.61	0.70	
Final pressure drop	1.5	1.5	1.5	
Cartridge filters—Varicel SH, 12" deep				
Efficiency	70%			
Rated velocity (FPM)	500			
Initial pressure drop	0.39			
Final pressure drop	1.2			
Pleated panel filters				
Type	Perfect pleat	AMAir 1300 4"		
Efficiency	30%	30%		
Rated Velocity (FPM)	500	625		
Initial Pressure Drop	0.36	0.36		
Final Pressure Drop	1.0	1.0		
5700 filters				
Efficiency	N/A			
Rated velocity (FPM)	500			
Initial pressure drop	0.25			
Final pressure drop	1.0			
Pleated 62 Plus filters				
Size	2"	4"		
Efficiency	70%	70%		
Initial pressure drop	0.42	0.37		
Final pressure drop	1.0	1.0		

## Coils

### CAUTION

Sharp fin edges are a potential injury hazard. Avoid contact with them.

1. To obtain maximum performance, the coil must be clean. Check once a year under normal operating conditions and, if dirty, brush or vacuum clean. Use a chemical coil cleaner on multiple row coils. Read and follow the chemical cleaner's instructions as some cleaners may contain harsh chemicals. Take care not to damage fins while cleaning. **CAUTION—Fin edges are sharp.**
2. Drain pans in any air conditioning unit may have some moisture. Algae, etc., can grow due to airborne spores and bacteria. Periodic cleaning is necessary to prevent this buildup from plugging the drain and causing the drain pan to overflow. Also, keep the drain pans clean to prevent the spread of disease. Cleaning should be performed by qualified personnel.
3. Dirt and lint can clog the condensate drain, especially with dirty filters. Inspect twice a year to help avoid overflow.

## Winterizing Water Coils

### WARNING

Mold can cause personal injury. Clean drain pan regularly so mold does not develop.

Coils can freeze due to air stratification or failure of outdoor air dampers and/or preheat controls. Drain all coils as thoroughly as possible and then treat in the following manner.

- Fill each coil independently with an antifreeze solution using a small circulating pump and again thoroughly drain.
- Check freezing point of antifreeze before proceeding to next coil. Due to a small amount of water always remaining in each coil, there is a diluting effect. The small amount of antifreeze solution remaining in the coil must always be sufficient enough to prevent freeze-up.

**NOTE:** Carefully read instructions for mixing antifreeze solution used. Some products have a higher freezing point in their natural state when mixed with water. Daikin Applied is not responsible for the freezing of coils.

## Removing and Replacing Components

### WARNING

Before removing any component, lock out and tag out all power to the unit. Fans and belts can cause severe personal injury or death.

## Removing a Side or Top Panel

1. Remove the flat head fasteners located along the sides of the panel.
2. Once all fasteners are removed, lift off the panel.

## Removing a Frame Channel

Frame channels that run the length of the unit along the top can be removed to allow access to both the side and top of the unit.

1. First remove any adjoining side and top panel(s).
2. Once the side panel is off, remove the flat head fasteners in the corner of the frame channels.
3. Pull the frame channel out the side.
4. If any top panel fastens into the frame channel (when the frame channel is 24" or wider in direction of air flow), remove the fasteners in the top panel before pulling out the channel.



## Removing the Fan Section

The fan shaft, motor, and any drive components can be removed and replaced through the access door opening. If required, the side panel can be removed for additional access.

If fan replacement is required, the entire fan assembly can be pulled out the side of the cabinet for housed fan assemblies. The fan assembly includes the fan housing, the bearing support, and the fan base.

1. Remove the side panels and any intermediate supports (follow instructions for side panel removal).
2. Once the panels and any intermediate supports are removed, disconnect the neoprene bulk head seal that is attached to the fan discharge.
3. Remove the four discharge angles that hold the neoprene canvas in place around the discharge opening.
4. Disconnect the fan sled from each of the corner mounts and pull the entire assembly out the side of the unit.
5. After the fan sled is out, loosen the fan bearings and pull out the shaft.
6. Disconnect the fan housing from the fan sled, and bearing support by removing the attaching bolts.
7. Replace the new fan, reconnect the shaft and bearings and put the fan assembly in the cabinet.
8. Replace panels and fasteners.

For plenum fan assemblies, the entire fan cabinet may need to be removed to replace the entire fan assembly depending on the length of the fan section. In some cases, the fan section is not long enough for the assembly to fit out the side of the cabinet. For those cases where it will fit, follow the above steps except the neoprene seal is a D-gasket on the inlet side that needs to be removed for plenum fans. Otherwise, the entire fan cabinet must be removed from the other sections and then the fan assembly can be removed out the discharge side of the cabinet.

## Removing and Replacing the Coil

The coil can be removed by the side, top, or a combination of both. The size and configuration of the coil affects how the coil can be removed. Single banks of coil are fastened only on the connection side of the unit. Stacked and staggered coils are fastened on both ends of the coil. See the instructions below for details to remove each coil type.

Before removing the coil, disconnect all piping. The instructions below assume the coil is mounted in a sectionalized coil section where the frame channel can be removed without affecting other components. If the coil section is unitized with other components, removing the top frame channel requires removing additional panels.

### Removing Single Coils

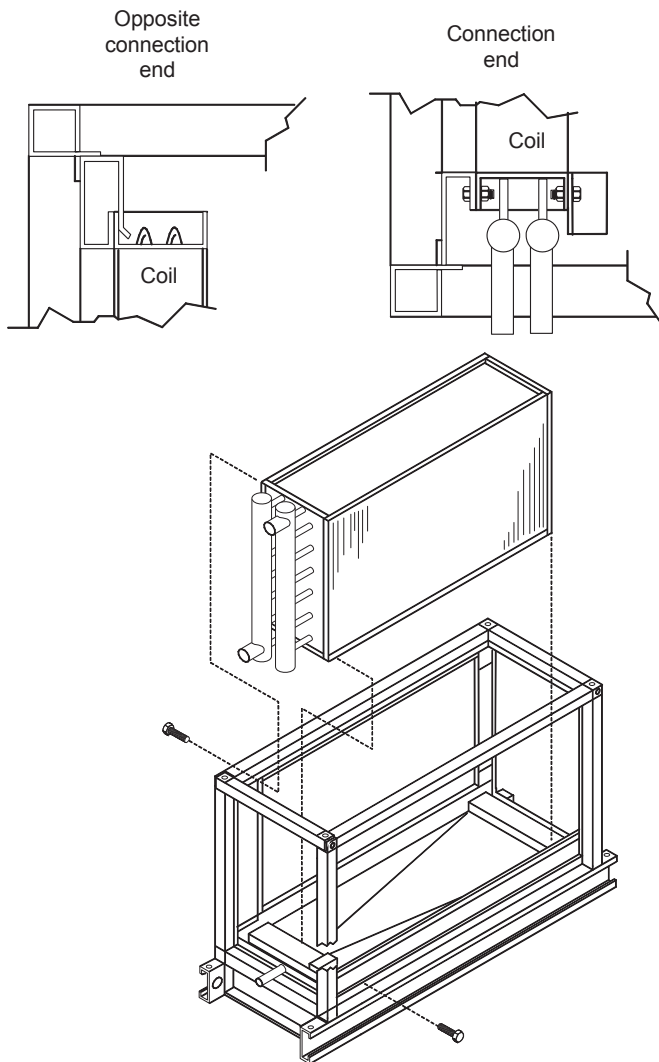
**NOTE:** Single coils are bolted to the unit on the connection end. The connection end is held in place with a clamp.

1. Disconnect all piping and remove the brass plugs for the vents and drains located in the connections.
2. Remove all screws and remove the access panel.
3. Remove the screws holding the coil in place.
4. Lift and pull the coil out the side.

### Installing Single Coils

1. Slide the coil through the opening in the coil section onto the bottom coil rests.
2. To prevent any air bypass around the coil, place coils up against the coil bulkheads (refer to [Figure 99](#)).
3. Once the coil is in place, fasten the coil to the section.
4. Caulk the seams between the coil casings and bulkheads (refer to [Figure 99](#)).
5. If this is an additional coil being installed and not a replacement, locate the coil supply and return connections dimensionally. Carefully drill holes in the end panels of the unit.
6. Remove the brass plugs for the vents and drains on the connections.
7. Slip the panel over the connections.
8. Replace the brass plugs and panel fasteners.

**Figure 99: Single Coil Removal**



**Removing Stacked Coils**

**NOTE:** Top and bottom stacked coils are held together with steel plate and screws on one side and drain trough and screws on the other side. Remove the plate and trough before removing the coils. The coils cannot be removed attached together.

1. Disconnect all piping and remove the brass plugs for the vents and drains located in the connections.
2. Remove all screws and remove the access panel.
3. Remove the bolts holding the coil in place and then lift and pull the coil bank and drain trough.
4. Remove the steel plate and the drain trough that hold the coils together.
5. Remove the bolts on both ends of the top coil holding it in place and then lift and slide the coil out.
6. Remove the bolts on both ends of the bottom coil holding it in place and then lift and slide the coil out.

**Installing Stacked Coils**

1. Slide the bottom coil through the opening in the coil section onto the bottom coil rests.
2. Place the coil up against the coil bulkheads to prevent any air bypass around the coil.
3. Once the coil is in place, bolt the coil to the section.
4. Caulk the mounting surface of the steel plate and install the plate on the coils.
5. Caulk the mounting surface of the drain trough and install the drain trough on the coils.
6. Caulk the seams between the coil casings and blockoffs.
7. Connect all piping and install the brass plugs for the vents and drains located in the connections.
8. Install the access panel.

**Removing and Installing Staggered Coils**

Staggered coils have two banks of coils positioned a few inches apart in the direction of airflow. Both coils are secured to the unit on the connection and opposite connection end of the unit.

1. Disconnect all piping and remove the brass plugs for the vents and drains located in the connections.
2. To access bolts holding the coils in place, remove the panels on both the connection and opposite connection end of the coil section.
3. Each coil is held in place with bolts located in the corners of the coil side plates. Remove the bolts and then lift and pull the coil out the side.
4. The bottom coil is fastened to the air block off plate. Remove the screws attaching this plate to the coil.
5. Once the fasteners holding the coil in place are removed, pull out the coil from either side of the unit.
6. Install the coils in reverse order of removal.

## Replacement Parts

When writing to Daikin Applied for service or replacement parts, refer to the model number and serial number of the unit stamped on the serial plate attached to the unit. If replacement parts are required, mention the date of installation of the unit and date of failure, along with an explanation of the malfunctions and a description of the replacement parts required.

## Service and Warranty Procedure

### Warranty

Consult your local Daikin Applied Representative for warranty details. To find your local Daikin Applied Representative, go to [www.DaikinApplied.com](http://www.DaikinApplied.com).

## Warranty Return Material Procedure

Defective material may not be returned without permission of authorized factory service personnel of Daikin Applied in Minneapolis, Minnesota, (763) 553-5330. A "Return Goods" tag must be included with the returned material. Enter the required information to expedite handling and prompt issuance of credits. All parts must be returned to the appropriate Daikin Applied facility, designated on the "Return Goods" tag. Transportation charges must be prepaid.

The return of the part does not constitute an order for replacement. Therefore, a purchase order must be entered through the nearest Daikin Applied Representative. The order should include part number, model number, and serial number of the unit involved.

Credit will be issued on customer's purchase order following an inspection of the return part and upon determination that the failure is due to faulty material or workmanship during the warranty period.

# Check, Test, and Start Procedure Form



## Air Handling Equipment Warranty Registration Form

To comply with the terms of Daikin Applied Warranty, complete and return this form within 10 days to the Warranty Department of Daikin Applied.

Check, test, and start procedure for air handling units with or without heat recovery and roof mounted air handlers.

### GENERAL INFORMATION

Job Name: \_\_\_\_\_ Unit No.: \_\_\_\_\_

SOI No.: \_\_\_\_\_

Installation address: \_\_\_\_\_

City: \_\_\_\_\_ State: \_\_\_\_\_

Purchasing contractor: \_\_\_\_\_

City: \_\_\_\_\_ State: \_\_\_\_\_

Name of person doing start-up: \_\_\_\_\_

Company name: \_\_\_\_\_

Address: \_\_\_\_\_

City/State/Zip: \_\_\_\_\_

### UNIT INFORMATION

Unit model number: \_\_\_\_\_ Unit serial number: \_\_\_\_\_

SF VFD model number: \_\_\_\_\_ Serial number: \_\_\_\_\_

RF VFD model number: \_\_\_\_\_ Serial number: \_\_\_\_\_



**AHU Equipment Warranty Registration Form (continued)**

Select Yes or No. If not applicable to the type of unit, select N/A.

**I. INITIAL CHECK**

- A. Is any shipping damage visible? . . . . .  Yes  No  N/A
- B. Are fan drives properly aligned and belts properly adjusted? . . . . .  Yes  No  N/A
- C. Tightened all setscrews on pulleys, bearings and fans? . . . . .  Yes  No  N/A
- D. Have the hold-down bolts been backed off on spring mounted fan isolators? . . . . .  Yes  No  N/A
- E. With the power off, do fans turn freely by hand? . . . . .  Yes  No  N/A
- F. Electrical service corresponds to unit nameplate? . . . . .  Yes  No  N/A

Volts \_\_\_\_\_ Hertz \_\_\_\_\_ Phase \_\_\_\_\_

- G. Is the main disconnect adequately fused and are fuses installed? . . . . .  Yes  No  N/A
- H. Are all electrical power connections tight? (Check compressor, electrical box.) . . . . .  Yes  No  N/A
- I. Is the condensate drain trapped? . . . . .  Yes  No  N/A
- J. Fill the drain pan. Does water drain freely? . . . . .  Yes  No  N/A
- K. Is the unit mounted level? . . . . .  Yes  No  N/A

**II. FAN DATA**

A. Check rotation of supply fan(s)? . . . . .  Yes  No  N/A

B. Voltage at supply fan motor(s): . . . . . 1-2 \_\_\_\_\_ V 2-3 \_\_\_\_\_ V 1-3 \_\_\_\_\_ V

\*Fan array units only . . . . . 1-2 \_\_\_\_\_ V 2-3 \_\_\_\_\_ V 1-3 \_\_\_\_\_ V

1-2 \_\_\_\_\_ V 2-3 \_\_\_\_\_ V 1-3 \_\_\_\_\_ V

1-2 \_\_\_\_\_ V 2-3 \_\_\_\_\_ V 1-3 \_\_\_\_\_ V

1-2 \_\_\_\_\_ V 2-3 \_\_\_\_\_ V 1-3 \_\_\_\_\_ V

1-2 \_\_\_\_\_ V 2-3 \_\_\_\_\_ V 1-3 \_\_\_\_\_ V

C. Supply fan motor amp draw(s) per phase: . . . . . L1 \_\_\_\_\_ L2 \_\_\_\_\_ L3 \_\_\_\_\_

\*Fan array units only . . . . . L1 \_\_\_\_\_ L2 \_\_\_\_\_ L3 \_\_\_\_\_

L1 \_\_\_\_\_ L2 \_\_\_\_\_ L3 \_\_\_\_\_

L1 \_\_\_\_\_ L2 \_\_\_\_\_ L3 \_\_\_\_\_

L1 \_\_\_\_\_ L2 \_\_\_\_\_ L3 \_\_\_\_\_

L1 \_\_\_\_\_ L2 \_\_\_\_\_ L3 \_\_\_\_\_

D. Overload amp setting: . . . . . \_\_\_\_\_

E. What is the supply fan rpm? . . . . . \_\_\_\_\_

F. Check rotation of return fan(s)? . . . . .  Yes  No  N/A



**AHU Equipment Warranty Registration Form (continued)**

Select Yes or No. If not applicable to the type of unit, select N/A.

G. Voltage at return fan motor(s): . . . . . 1-2 \_\_\_\_\_ V 2-3 \_\_\_\_\_ V 1-3 \_\_\_\_\_ V  
 \*Fan array units only . . . . . 1-2 \_\_\_\_\_ V 2-3 \_\_\_\_\_ V 1-3 \_\_\_\_\_ V  
 1-2 \_\_\_\_\_ V 2-3 \_\_\_\_\_ V 1-3 \_\_\_\_\_ V  
 1-2 \_\_\_\_\_ V 2-3 \_\_\_\_\_ V 1-3 \_\_\_\_\_ V  
 1-2 \_\_\_\_\_ V 2-3 \_\_\_\_\_ V 1-3 \_\_\_\_\_ V  
 1-2 \_\_\_\_\_ V 2-3 \_\_\_\_\_ V 1-3 \_\_\_\_\_ V

H. Return fan motor amp draw(s) per phase: . . . . . L1 \_\_\_\_\_ L2 \_\_\_\_\_ L3 \_\_\_\_\_  
 \*Fan array units only . . . . . L1 \_\_\_\_\_ L2 \_\_\_\_\_ L3 \_\_\_\_\_  
 L1 \_\_\_\_\_ L2 \_\_\_\_\_ L3 \_\_\_\_\_  
 L1 \_\_\_\_\_ L2 \_\_\_\_\_ L3 \_\_\_\_\_  
 L1 \_\_\_\_\_ L2 \_\_\_\_\_ L3 \_\_\_\_\_  
 L1 \_\_\_\_\_ L2 \_\_\_\_\_ L3 \_\_\_\_\_

I. Overload amp setting: . . . . . \_\_\_\_\_

J. What is the return fan rpm? . . . . . \_\_\_\_\_

K. Record supply static pressure at unit in inches of H<sub>2</sub>O: . . . . . \_\_\_\_\_

L. Record return static pressure at unit (with outside air dampers closed) in inches of H<sub>2</sub>O: . . . . . \_\_\_\_\_

\* If additional fans are on the unit, please add them to the space below.

**III. DAMPERS**

A. Are blades and seals present? . . . . .  Yes  No  N/A  
 B. Do damper open smoothly and shut tight? . . . . .  Yes  No  N/A



**AHU Equipment Warranty Registration Form (continued)**

Select Yes or No. If not applicable to the type of unit, select N/A.

**IV. ELECTRIC HEAT**

A. Electrical heat service corresponds to unit nameplate? . . . . .  Yes  No  N/A

Volts \_\_\_\_\_ Hertz \_\_\_\_\_ Phase \_\_\_\_\_

B. Are there any signs of physical damage to the electric heat coils? . . . . .  Yes  No  N/A

C. Have all electrical terminals been tightened? . . . . .  Yes  No  N/A

D. Does sequence controller stage contactors properly? . . . . .  Yes  No  N/A

E. Electric heater voltage across each phase: . . . . . \_\_\_\_\_ L1 \_\_\_\_\_ L2 \_\_\_\_\_ L3

F. Amp draw across each phase at each heating stage:

	Stage 1	Stage 2	Stage 3	Stage 4	Stage 5	Stage 6
Phase L1:	_____	_____	_____	_____	_____	_____
Phase L2:	_____	_____	_____	_____	_____	_____
Phase L3:	_____	_____	_____	_____	_____	_____

G. FLA: L1 \_\_\_\_\_ L2 \_\_\_\_\_ L3 \_\_\_\_\_

H. Operate electric heat with fans off. Electric heat must cycle on high limit control . . . . .  Yes  No  N/A

**V. CHILLED WATER COIL**

A. Pressure test OK? . . . . .  Yes  No  N/A

B. Drain pan draining OK? . . . . .  Yes  No  N/A

**VI. HOT WATER COIL**

A. Pressure test OK? . . . . .  Yes  No  N/A

**VII. HEAT RECOVERY**

A. Heat wheel rotates freely? . . . . .  Yes  No  N/A

B. Heat wheel VFD operates properly? . . . . .  Yes  No  N/A

C. Heat wheel VFD: . . . . . Model # \_\_\_\_\_ Serial # \_\_\_\_\_

D. Check for air bypass around heat wheel. . . . .  Yes  No  N/A





**AHU Equipment Warranty Registration Form (continued)**

Select Yes or No. If not applicable to the type of unit, select N/A.

**VIII. Design Flow calibration**

- A. Verify power is supplied to the MicroTech III unit controller . . . . .  Yes  No  N/A
- B. Verify that the shipping screws have been removed from the measuring station vane . . . . .  Yes  No  N/A
- C. Examine station for damage . . . . .  Yes  No  N/A
- D. Record Level Position after calibration
  - LH Level Position . . . . . \_\_\_\_\_
  - RH Level Position . . . . . \_\_\_\_\_

NOTE: This is viewed in the MicroTech III controller, in the Min OA setup menu.

**IX. GAS BURNER CHECK, TEST, & START**

**Specifications:**

For gas, see **Forced Draft Gas Burner Installation and Maintenance Bulletin. (IM 684 and IM 685)**

- A. Gas Furnace: . . . . . Model no. \_\_\_\_\_
- B. Gas Burner: . . . . . Model no. \_\_\_\_\_ Serial no. \_\_\_\_\_
- C. Gas Type firing: . . . . . Single Stage \_\_\_\_\_ Modulation \_\_\_\_\_
- D. Gas Rated firing rate (MBH input): . . . . . \_\_\_\_\_
- E. Gas Altitude (ft. above sea level): . . . . . \_\_\_\_\_
- F. Is there a circulating tank? . . . . .  Yes  No  N/A
- G. Input (CFH): . . . . . \_\_\_\_\_
- H. Gas pressure at burner (inches w.c.): . . . . . \_\_\_\_\_
- I. CO<sub>2</sub> (%): . . . . . \_\_\_\_\_
- J. CO<sub>2</sub> (%): . . . . . \_\_\_\_\_
- K. Pilot flame only in microamps (steady at low fire): . . . . . \_\_\_\_\_
- L. Pilot Tap-gas pressure (inches w.c.): . . . . . \_\_\_\_\_
- M. Motor only/burner FLA running amps: . . . . . \_\_\_\_\_
- N. High limit control OK? . . . . .  Yes  No  N/A
- O. Flame safeguard (microamps): . . . . . \_\_\_\_\_
- P. Flame failure shutoff (seconds): . . . . . \_\_\_\_\_



**AHU Equipment Warranty Registration Form (continued)**

Select Yes or No. If not applicable to the type of unit, select N/A.

- Q. Airswitch OK? . . . . .  Yes  No  N/A
- R. High Gas Pressure Switch OK? . . . . .  Yes  No  N/A
- S. Low Gas Pressure Switch OK? . . . . .  Yes  No  N/A
- T. Main Gas Valve Close-off OK?. . . . .  Yes  No  N/A

Thank you for completing this form. Please sign and date below.

Signature \_\_\_\_\_ Startup date: \_\_\_\_\_

**Return completed form by mail to:**

Daikin Warranty Department, 13600 Industrial Park Boulevard, Minneapolis, MN 55441

or by email to: [AAH.Wty\\_WAR\\_forms@daikinapplied.com](mailto:AAH.Wty_WAR_forms@daikinapplied.com)

Please fill out the Daikin Applied "Quality Assurance Survey Report" and list any additional comments that could affect the operation of this unit; e.g., shipping damage, failed components, adverse installation applications, etc. If additional comment space is needed, write the comment(s) on a separate sheet, attach it to the Survey Report and return it to the Warranty Department of Daikin Applied with the completed Equipment Warranty Registration form.

**Submit Form**

**Clear Form**

# Quality Assurance Survey Report



## Quality Assurance Survey Report

To whom it may concern:

Please review the items below upon receiving and installing our product. Select N/A on any item that does not apply to the product.

**Job Name:** \_\_\_\_\_ **Daikin Applied S.O. No.** \_\_\_\_\_

Installation address: \_\_\_\_\_

City: \_\_\_\_\_ State: \_\_\_\_\_

Purchasing contractor: \_\_\_\_\_

City: \_\_\_\_\_ State: \_\_\_\_\_

**Name of person doing start-up (print):** \_\_\_\_\_

Company name: \_\_\_\_\_

Address: \_\_\_\_\_

City/State/Zip: \_\_\_\_\_

**Unit model number:** \_\_\_\_\_ **Unit serial number:** \_\_\_\_\_

1. Is there any shipping damage visible? ..... Yes  No  N/A

Location on unit \_\_\_\_\_

2. How would you rate the overall appearance of the product; i.e., paint, fin damage, etc.? Excellent  Good  Fair  Poor

3. Did all sections of the unit fit together properly? ..... Yes  No  N/A

4. Did the cabinet have any air leakage? ..... Yes  No  N/A

Location on unit \_\_\_\_\_

5. Were there any refrigerant leaks? ..... Yes  No  N/A

From where did it occur? ..... Shipping  Workmanship  Design

6. Does the refrigerant piping have excessive vibration? ..... Yes  No  N/A

Location on unit \_\_\_\_\_

7. Did all of the electrical controls function at start-up? ..... Yes  No  N/A

Comments \_\_\_\_\_

8. Did the labeling and schematics provide adequate information? ..... Yes  No  N/A

9. How would you rate the serviceability of the product? Excellent  Good  Fair  Poor

10. How would you rate the overall quality of the product? Excellent  Good  Fair  Poor

11. How does the quality of Daikin Applied products rank in relation to competitive products? Excellent  Good  Fair  Poor

Comments \_\_\_\_\_

Please list any additional comments which could affect the operation of this unit; i.e., shipping damage, failed components, adverse installation applications, etc. If additional comment space is needed, write the comment(s) on a separate sheet, attach the sheet to this completed Quality Assurance Survey Report, and return it to the Warranty Department with the completed preceding "Equipment Warranty Registration Form".



### ***Daikin Applied Training and Development***

Now that you have made an investment in modern, efficient Daikin Applied equipment, its care should be a high priority. For training information on all Daikin Applied HVAC products, please visit us at [www.DaikinApplied.com](http://www.DaikinApplied.com) and click on Training, or call 540-248-9646 and ask for the Training Department.

### ***Warranty***

All Daikin Applied equipment is sold pursuant to its standard terms and conditions of sale, including Limited Product Warranty. Consult your local Daikin Applied Representative for warranty details. To find your local Daikin Applied Representative, go to [www.DaikinApplied.com](http://www.DaikinApplied.com).

### ***Aftermarket Services***

To find your local parts office, visit [www.DaikinApplied.com](http://www.DaikinApplied.com) or call 800-37PARTS (800-377-2787). To find your local service office, visit [www.DaikinApplied.com](http://www.DaikinApplied.com) or call 800-432-1342.

This document contains the most current product information as of this printing. For the most up-to-date product information, please go to [www.DaikinApplied.com](http://www.DaikinApplied.com).

Products manufactured in an ISO Certified Facility.