



Installation and Maintenance Manual

IM 1304-2

Group: Applied Terminal Systems

Document PN: IM1304-2

Date: November 2023

SmartSource® Compact Horizontal Water Source Heat Pump

Model GCH - Single Stage

Model GDH - Two Stage

Sizes 007 – 070 (1/2 thru 6 tons)

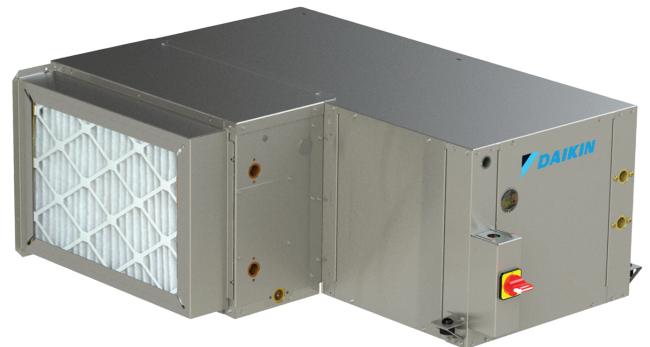
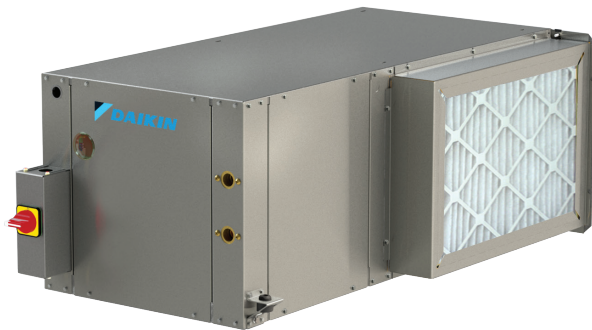

GCH with Waterside Economizer

Contents

Model Nomenclature	3	Controls	39
Safety Information	4	Jumper Configuration Settings	41
Hazard Identification	4	MicroTech® III SmartSource Unit Controller	42
General Information	5	MicroTech SmartSource Controller with LONWORKS® Communication Module	44
Receiving and Storage	5	MicroTech SmartSource Controller with BACnet® Communication Module	44
Pre-Installation Checklist	5	Fan Speed Selector Switch	46
Physical Data	6	Initial Start-up	52
System Applications	8	Check, Test & Start Procedure	52
Water Loop Application	8	Operating Limits	53
Ground-Loop Application	8	Environment	53
Ground-Water Application	12	Air Limits	53
Water System Quality	14	Fluid Limits	53
Supply & Return Piping	15	Field-Installed Accessory	54
Discharge Air Conversion	20	Control Wiring Schematics	55
Ductwork and Attenuation	20	Line Voltage Wiring Schematics	62
Air Duct Connections	22	General Maintenance	66
Installation - GCH Horizontal Unit	23	Lubrication	66
Filter Rack, Return Duct Collar Dimensions	23	Charging	66
Discharge Air Duct Collar Connections	24	Troubleshooting	68
Electrical Connections	25	Typical Refrigeration Cycles	69
GCH Unit With Non-Fused Disconnect Switch	28	Water Source Heat Pump Equipment Check, Test and Start Form	70
Line Voltage Electrical Connections With Disconnect – 115-575V	29		
Low Voltage Wire Connections	30		
Typical Connections For Thermostats & Temperature Sensors Applications	31		
Piping	35		
Units With Waterside Economizer	35		
Waterside Economizer Piping Locations and Dimensions	36		
Unit Supply and Return and Condensate Drain Connections	37		
Piping Considerations	37		
Condensate Drain - General	38		
Cleaning & Flushing System	38		

©2023 Daikin Applied, Minneapolis, MN. All rights reserved throughout the world. This document contains the most current product information as of this printing. Daikin Applied Americas Inc. has the right to change the information, design, and construction of the product represented within the document without prior notice. For the most up-to-date product information, please go to www.DaikinApplied.com.

™ SmartSource, MicroTech, and Daikin Applied are trademarks or registered trademarks of Daikin Applied Americas Inc. The following are trademarks or registered trademarks of their respective companies: BACnet from American Society of Heating, Refrigerating and Air-Conditioning Engineers, Inc.; Echelon, LonWorks, LonMark, and LonTalk from Echelon Corporation; Modbus from Schneider Electric; and Windows from Microsoft Corporation.

1	2-3	4	5-7	8	9	10-11	12	13	14	15	16-17	18	19	20	21	22	23-24	25	26	27
W	GC	H	007	E	1	LS	S	M	T	D	WE	2	1	P			75	E	D	3

Category	Code Option	Code Designation	Description
Product Category	1	W	= Water Source Heat Pump
Model Type	2-3	GC	= Compact Single Stage
		GD	= Compact Two Stage
Configuration	4	H	= Horizontal
Nominal Capacity	5-7	007	= 7,000 Btuh Nominal Cooling
		009	= 9,000 Btuh Nominal Cooling
		012	= 12,000 Btuh Nominal Cooling
		015	= 15,000 Btuh Nominal Cooling
		019	= 19,000 Btuh Nominal Cooling
		024	= 24,000 Btuh Nominal Cooling
		030	= 30,000 Btuh Nominal Cooling
		042	= 42,000 Btuh Nominal Cooling
		048	= 48,000 Btuh Nominal Cooling
		060	= 60,000 Btuh Nominal Cooling
Voltage	8	A	= 115/60/1 (007-015)
		E	= 208-230/60/1 (007-070)
		F	= 208-230/60/3 (024-070)
		J	= 265/60/1 (007-036)
		K	= 460/60/3 (024-070)
		L	= 575/60/3 (048-070)
Design Series (Vintage)	9	1	= Revision / Design Series 1
Return Air / Discharge Air	10-11	LS	= Left Hand Return / Straight Discharge
		LE	= Left Hand Return / End Discharge
		RS	= Right Hand Return / Straight Discharge
		RE	= Right Hand Return / End Discharge
Water Coil Type	12	C	= Copper Inner Tube
		S	= Cupro-Nickel Inner Tube
		G	= Geothermal - Copper Inner Tube
		J	= Geothermal - Cupro-Nickel
Unit Control	13	M	= MicroTech III SmartSource Unit Controller
		L	= MicroTech III Unit Controller + LoN
		B	= MicroTech III Unit Controller + BACnet
Fan Motor	14	P	= PSC
		C	= ECM Constant CFM
		T	= ECM Constant Torque
Insulation (Compressor Side / Airside)	15	B	= Standard (1/2" Fiberglass, Entire Unit)
		I	= IAQ (Closed Cell Foam, Entire Unit)
		D	= Dual Layer Fiberglass (Entire Unit) (sizes 007-019)
		F	= Sound Blanket + Standard (1/2" Fiberglass)(sizes 024-070)
		G	= Sound Blanket + IAQ (Closed Cell Foam) (sizes 024-070)
		H	= Sound Blanket + Sound Package (1" Fiberglass / Dual Layer Fiberglass) (sizes 024-070)
Options	16-17	WE	= Waterside Economizer
		HG	= Hot Gas Reheat
Filter & Racks	18	1	= Standard 1" Rail - 1" Throwaway Filter
		2	= 2" Rack - 2" Filter (MERV 8)
		4	= 4" Rack - 4" Filter (MERV 13)
Two-Way Motorized Valve	19	0	= None
		1	= Isolation Valve (Normally Open) (Available only on sizes 015-070)
		2	= Isolation Valve (Normally Closed) (Available only on sizes 015-070)
Electric Heat	20	0	= None
		P	= Control for Electric Heat Single 24V Signal (Field Installed Duct Heater by Others)
Additional Options	21	0	= None
		F	= Freeze Fault Protection
		A	= Alarm Relay
		B	= Alarm Relay and Freeze Fault Protection
		C	= Pressure Differential Switch
		D	= Freeze Fault Protection and Pressure Differential Switch
		E	= Alarm Relay and Pressure Differential Switch
G	= Alarm Relay, Freeze Fault Protection and Pressure Differential Switch		

Nomenclature (Continued)

1	2-3	4	5-7	8	9	10-11	12	13	14	15	16-17	18	19	20	21	22	23-24	25	26	27
W	GC	H	007	E	1	LS	S	M	T	D	WE	2	1	P			75	E	D	3

Category	Code Option	Code Designation	Description
Standard or Special	22	S	= Standard
		X	= Special
Transformer	23-24	50	= 50VA Transformer
		75	= 75VA Transformer
Corrosion Protection	25	0	= Stainless Steel Drain Pan
		A	= Plastic Drain Pan
		E	= Corrosion Protection with Stainless Steel Drain Pan (Coated Air Coil Includes WSE and HGRH if applicable)
		F	= Corrosion Protection with Plastic Drain Pan (Coated Air Coil Includes WSE and HGRH if applicable)
Disconnect Switch	26	0	= None
		D	= Disconnect Switch

Safety Information

⚠ WARNING

This Installation and Maintenance bulletin is intended to provide the proper procedures for installing a Daikin Water Source Heat Pump. Failure to follow these procedures can cause property damage, severe personal injury or death. Additional, failure to follow these procedures can cause premature failure of this equipment or cause erratic unit operation, resulting in diminished unit performance. Disregarding these directions may further lead to suspension or revocation of the manufacturer's warranty.

Hazard Identification

⚠ DANGER

Danger indicates a hazardous situation, which will result in death or serious injury if not avoided.

⚠ WARNING

Warning indicates a potentially hazardous situations, which can result in property damage, personal injury, or death if not avoided.

⚠ CAUTION

Caution indicates a potentially hazardous situations, which can result in minor injury or equipment damage if not avoided.

NOTICE

Notice indicates practices not related to physical injury.

NOTE: Indicates important details or clarifying statements for information presented.

General Information

Receiving and Storage

CAUTION

Sharp edges can cause minor injury. Avoid contact with them.

Upon receipt of the equipment, check carton for visible damage. Make a notation on the shipper's delivery ticket before signing. If there is any evidence of rough handling, immediately open the cartons to check for concealed damage. If any damage is found, notify the carrier within 48 hours to establish your claim and request their inspection and a report. The Warranty Claims Department should then be contacted.

For storing, each carton is marked with "up" arrows.

The unit should be shipped or stored in the normal upright position. Do not operate the machine until it has been in the normal upright position for at least 24 hours.

Temporary storage at the job site must be indoor, completely sheltered from rain, snow, etc. Units should not be installed in environments that fall below freezing or exceed 140°F ambient.

IMPORTANT

This product was carefully packed and thoroughly inspected before leaving the factory. Responsibility for its safe delivery was assumed by the carrier upon acceptance of the shipment. Claims for loss or damage sustained in transit must therefore be made upon the carrier as follows:

VISIBLE LOSS OR DAMAGE

Any external evidence of loss or damage must be noted on the freight bill or carrier's receipt, and signed by the carrier's agent. Failure to adequately describe such external evidence of loss or damage may result in the carrier's refusal to honor a damage claim. The form required to file such a claim will be supplied by the carrier.

CONCEALED LOSS OR DAMAGE

Concealed loss or damage means loss or damage which does not become apparent until the product has been unpacked. The contents may be damaged in transit due to rough handling even though the carton may not show external damages. When the damage is discovered upon unpacking, make a written request for inspection by the carrier's agent within fifteen (15) days of the delivery date and file a claim with the carrier.

WARNING

The installer must determine and follow all applicable local and national codes and regulations. This equipment presents hazards of electricity, rotating parts, sharp edges, heat and weight. Failure to read and follow these instructions can result in property damage, personal injury or death. This equipment must be installed by experienced, trained personnel only.

WARNING

This appliance is not intended for use by persons (including children) with reduced physical, sensory or mental capabilities, or lack of experience and knowledge, unless they have been given supervision or instruction concerning use of the appliance by a person responsible for their safety.

Children should be supervised to ensure that they do not play with the appliance.

This appliance shall be installed in accordance with national wiring regulations (national electric code, Canadian electric code)

Pre-Installation Checklist

- To prevent damage, do not operate this equipment for supplementary ventilation, heating and cooling during the construction period.
- Inspect the carton for any specific tagging numbers indicated by the factory per a request from the installing contractor.
- Check the unit data plate for correct voltage, phase and capacity with the plans before installing the equipment. Also, make sure all electrical ground connections are made in accordance with local code.

Table 1: Operating Voltages

Voltage	Minimum	Maximum
115/60/1	103	126
208-230/60/1	197	253
265/60/1	238	292
208-230/60/3	197	253
460/60/3	414	506
575/60/3	515	632

Note: Three-phase system imbalance shall not exceed 2%.

- If 460/60/3 unit includes a constant CFM EC motor verify that a 4-wire power supply is provided that includes a neutral wire providing 265 volt power to the fan motor.
- Check the unit size against the plans to verify that the unit is being installed in the correct location.
- Before installation, check the available ceiling height versus the height of the unit.
- Note the location and routing of water piping, condensate drain piping, and electrical wiring. The locations of these items are clearly marked on submittal drawings.
- The installing contractor will find it beneficial to confer with piping, sheet metal, and electrical foremen before installing any unit.
- The contractor shall cover the units to protect the machines during building construction. This is critical while spraying fireproofing material on bar joists, sandblasting, spray painting and plastering. If plastic film is not available, the shipping carton may be modified to cover the units during construction.
- Remove shipping brackets securing unit to skid.

Physical Data

Table 2: GCH Unit Sizes 007 Through 030

Description		Unit Size							
		007	009	012	015	019	024	030	
Compressor Type		Rotary				Scroll			
Refrigeration Charge (Oz.)	Single Stage	16		208V-20 ozs 265V-18 ozs	28	34	37	36	
	Two Stage	N/A				37	34		
HGRH Refrigeration Charge Adder (Oz.)		N/A			6	7			
Fan Wheel (D x W)		6" x 8"			9" x 7"				
PSC Fan Motor HP		1/8			1/6	1/4	1/3		
EC Constant Torque Motor HP		1/10			1/3	1/3 (1/2 for 460V)			
EC Constant CFM Motor HP		N/A			1/3	1/3			
Water Connection Size (FPT)		1/2"				3/4"			
Coax Volume (Gal. @ 70°F)		0.10		0.12		0.22			
Condensate Connection Size (FPT)		3/4							
Air Coil Face Area (Sq. Ft.)		1.16			2.38	2.33			
Filter Size, Standard 1" deep (inches)		10" x 20"			16" x 25"		16" x 24"		
Operating Weight (Lbs.)		99		103	142	150	182		
Shipping Weight (Lbs.)		123	123	128	168	176	209		
Overall Cabinet Dimensions (W x D x H)		19 x 34 x 11.5			19 x 42 x 17		19 x 43 x 17.3		
Waterside Economizer Section (Lbs.)		22			33	41			
Waterside Economizer Coil Volume (Gal.)		.24			.55	.62			
Hot Gas Reheat (HGRH) Adder (Lbs.)		N/A			3.93	6.26			

Table 3: GCH Unit sizes 036 through 070

Description		Unit Size				
		036	042	048	060	070
Compressor Type		Scroll				
Refrigeration Charge (Oz.)	Single Stage	50	48	54	60	69
	Two Stage	49	48	51	59	69
HGRH Refrigeration Charge Adder (Oz.)		19		20		26
Fan Wheel (D x W)		9" x 7"	10" x 8"		11" x 10"	
PSC Fan Motor HP		1/3	1/2		3/4	
EC Constant Torque Motor HP		1/2		3/4	1	
EC Constant CFM Motor HP		1/2	3/4		1	
Water Connection Size (FPT)		3/4"		1"		
Coax Volume (Gal. @ 70°F)		0.43	0.48	0.82		
Condensate Connection Size (FPT)		3/4				
Air Coil Face Area (Sq. Ft.)		3.34		4.09	5.54	
Filter Size, Standard 1" deep (inches)		18" x 30"		16" x 20" (Qty 2)		20" x 22" (Qty 2)
Operating Weight		218	236	296	313	332
Shipping Weight		255	273	331	345	379
Overall Cabinet Dimensions (W x D x H)		21.5 x 49 x 21		24 x 54 x 21		24 x 65 x 21
Waterside Economizer Section (Lbs.)		50		53	60	
Waterside Economizer Coil Volume (Gal.)		.82		1.15	1.1	
Hot Gas Reheat (HGRH) Adder (Lbs.)		7.41		10.08		12.46

Table 4: Horizontal Unit Corner Weights, Percentage of Total Operating Weight (Base Unit Only)

Unit Size	007	009	012	015	019	024	030	036	042	048	060	070
Unit only Weight (lbs)	99	99	103	141	149	180	180	218	236	296	313	332
Left Side Weight (lbs.)	50	50	53	74	84	99	99	114	140	173	182	196
Compressor End Weight (lbs.)	41	41	43	76	82	98	98	96	132	162	170	190
Point A	22%	22%	22%	29%	31%	30%	30%	24%	34%	33%	33%	35%
Point B	20%	20%	20%	26%	24%	25%	25%	21%	22%	23%	23%	23%
Point C	28%	28%	28%	22%	20%	20%	20%	26%	17%	18%	18%	16%
Point D	30%	30%	30%	24%	26%	25%	25%	29%	26%	26%	26%	25%

Figure 1: Horizontal Unit Corner Weights - Letter Reference for Table 4

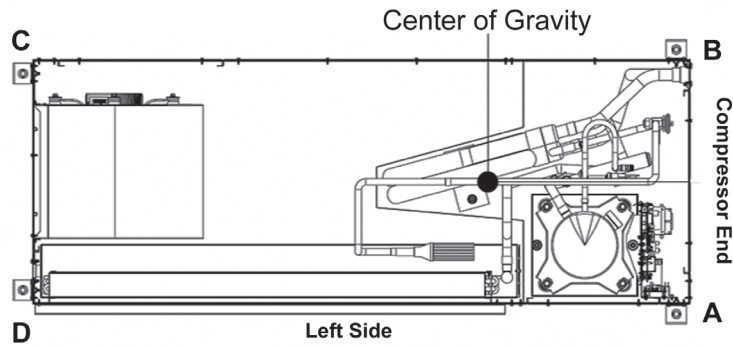

A (average) = 29% C (average) = 22%
 B (average) = 23% D (average) = 27%

System Applications

Water Loop Application

Commercial systems typically include a number of units connected to a common piping system. Any unit plumbing maintenance work can introduce air into the piping system; therefore air elimination equipment is a major portion of the mechanical room plumbing. In piping systems expected to utilize water temperatures below 50°F [10°C], closed cell insulation is recommended on all piping surfaces to eliminate condensation (extended range units required). Metal to plastic threaded joints should never be used due to their tendency to leak over time. All SmartSource units include flush mounted FPT water connections integral to the unit corner post, which do not require a backup wrench.

A thread sealant is recommended to minimize internal fouling of the heat exchanger. Do not over tighten connections and route piping so as not to interfere with service or maintenance access. Hose kits are available from Daikin in different configurations for connection between the unit and the piping system. Depending upon selection, hose kits may include shut off valves,

P/T plugs for performance measurement, high pressure stainless steel braided hose, “Y” type strainer with blow down valve, and/or “J” type swivel connection. Balancing valves and an external low pressure drop solenoid valve for use in variable speed pumping systems may also be included in the hose kit.

The piping system should be flushed to remove dirt, piping chips, and other foreign material prior to operation (see "Flushing the Earth Loop" on page 10). The water flow rates should be kept at approximately 3 GPM per nominal cooling ton (a 10°F temperature rise in cooling). To ensure proper maintenance and servicing, P/T ports are imperative for temperature and flow verification, as well as performance checks.

Water loop heat pump (cooling tower/boiler) systems typically utilize a common loop, maintained between 60 - 90°F [16 - 32°C]. When an open type cooling tower is used, a secondary heat exchanger between the tower and the water loop is recommended. If an open type cooling tower is used continuously, chemical treatment and filtering may be necessary.

Ground-Loop Application

CAUTION

The following instructions represent industry accepted installation practices for closed loop earth coupled heat pump systems. Instructions are provided to assist the contractor in installing trouble free ground loops. These instructions are recommendations only. State/provincial and local codes **MUST** be followed and installation **MUST** conform to ALL applicable codes. It is the responsibility of the installing contractor to determine and comply with ALL applicable codes and regulations.

CAUTION

Ground loop applications require extended range equipment and optional refrigerant/water circuit insulation.

Pre-Installation

Prior to installation, locate and mark all existing underground utilities, piping, etc. Install loops for new construction before sidewalks, patios, driveways, and other construction has begun. During construction, accurately mark all ground loop piping on the plot plan as an aid in avoiding potential future damage to the installation.

Piping Installation

The typical closed loop ground source system is shown in [Figure 3](#). All earth loop piping materials should be limited to polyethylene or equivalent per International Ground Source Heat Pump Association (IGSHPA)

Figure 2: Polyethylene Fused Piping



Galvanized or steel fittings should not be used at any time due to their tendency to corrode. All plastic to metal threaded fittings should be avoided due to their potential to leak in earth coupled applications. A flanged fitting should be substituted. P/T plugs should be used so that flow can be measured using the pressure drop of the unit heat exchanger.

Earth loop temperatures can range between 25 and 110°F [-4 to 43°C]. The water flow rates should be kept at approximately 3 GPM per nominal cooling ton (a 10°F temperature rise in cooling).

Test individual horizontal loop circuits before backfilling. Test vertical U-bends and pond loop assemblies prior to installation. Pressures of at least 100 psi [689 kPa] should be used when testing. Do not exceed the pipe pressure rating. Test entire system when all loops are assembled.

Figure 3: Typical Ground Loop Application (Loop Pump by Others Shown)

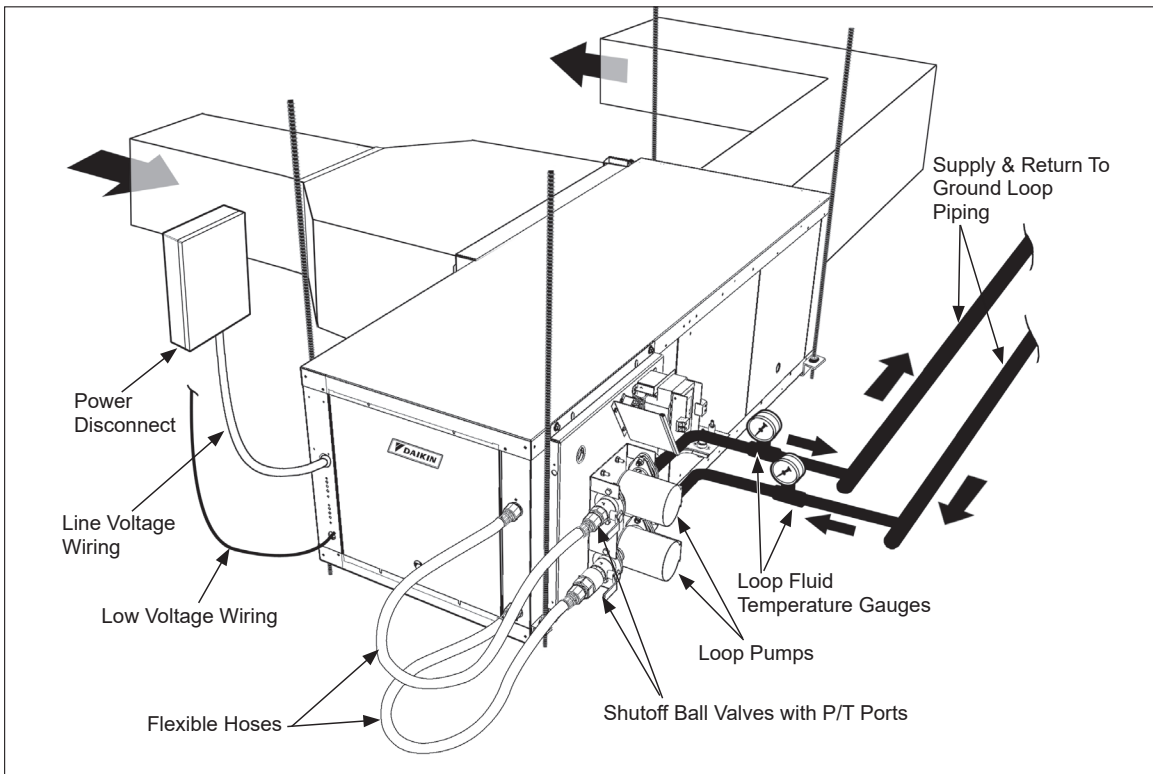

Flushing the Earth Loop

Upon completion of system installation and testing, flush the system to remove all foreign objects and purge to remove all air.

Antifreeze

In areas where minimum entering loop temperatures drop below 50°F [10°C] or where piping will be routed through areas subject to freezing, antifreeze is required.

Alcohols and glycols are commonly used as antifreeze; however your local sales office should be consulted to determine the antifreeze best suited to your area. Freeze protection should be maintained to 15°F [9°C] below the lowest expected entering loop temperature. For example, if 30°F [-1°C] is the minimum expected entering loop temperature, the leaving loop temperature would be 22 to 25°F [-6 to -4°C] and freeze protection should be at 15°F [-10°C]. Calculation is as follows: 30°F - 15°F = 15°F [-1°C - 9°C = -10°C].

All alcohols should be premixed and pumped from a reservoir outside of the building when possible or introduced under the water level to prevent fumes. Calculate the total volume of fluid in the piping system. Then use the percentage by volume shown in [Table 6](#) for the amount of antifreeze needed. Antifreeze concentration should be checked from a well mixed sample using a hydrometer to measure specific gravity.

Figure 4: Flushing The Loop

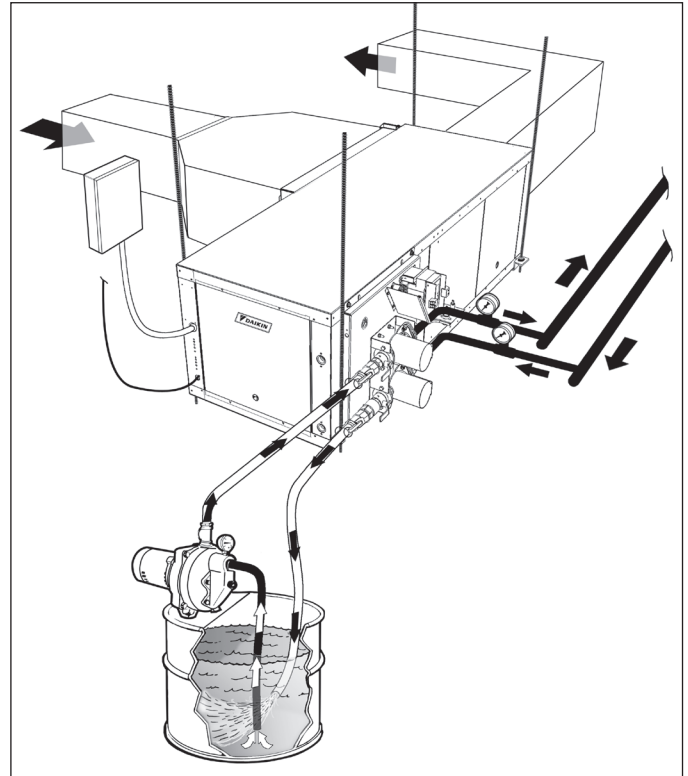

Table 5: Antifreeze Percentage By Volume

Type	Minimum Temperature for Low Temperature Protection			
	10°F [-12.2°C]	15°F [-9.4°C]	20°F [-6.7°C]	25°F [-3.9°C]
Methanol	25%	21%	16%	10%
100% USP food grade Propylene Glycol	38%	25%	22%	15%
Ethanol ¹	29%	25%	20%	14%

Note: ¹ Must not be denatured with any petroleum product.

Table 6: Antifreeze Correction Factors (For Heat Pump Operation Only)

	Antifreeze % By Weight			
	15%	25%	35%	45%
Ethanol				
Cooling Capacity	0.985	–	–	–
Heating Capacity	0.9825	–	–	–
Pressure Drop	1.04	–	–	–
Ethylene Glycol				
Cooling Capacity	0.9935	0.9895	0.985	0.981
Heating Capacity	0.9865	0.9795	0.973	0.965
Pressure Drop	1.10	1.16	1.22	1.27
Methanol				
Cooling Capacity	0.985	–	–	–
Heating Capacity	0.9825	–	–	–
Pressure Drop	1.04	–	–	–
Propylene Glycol				
Cooling Capacity	0.985	0.975	0.965	0.955
Heating Capacity	0.981	0.9685	0.952	0.936
Pressure Drop	1.11	1.20	1.31	1.40

Ground-Water Application

Open Loop - Ground Water Systems - Typical open loop piping is shown in [Figure 5](#). Shut off valves should be included for ease of servicing. Boiler drains or other valves should be installed in the supply and return lines to allow cleaning of the heat exchanger. Shut off valves should be positioned to allow flow through the coax via the boiler drains without allowing flow into the piping system. P/T plugs should be used so that pressure drop and temperature can be measured. Piping materials should be limited to copper.

⚠ WARNING

PVC or CPVC should not be used as they are not compatible with the POE oils used in HFC-410A products and piping system failure and property damage may result.

Water quantity should be plentiful and of good quality. See "Water impurities, result & recommended water system application" on [page 14](#) for water quality guidelines. The unit can be ordered with either a copper or cupro-nickel water heat exchanger. Consult [Table 8 on page 14](#) for recommendations. Copper is recommended for open loop ground water systems that are not high in mineral content or corrosiveness. In conditions anticipating heavy scale formation or in brackish water, a cupro-nickel heat exchanger is recommended. In ground water situations where scaling could be heavy or where biological growth such as iron bacteria will be present, an open loop system is not recommended. Heat exchanger coils may over time lose heat exchange capabilities due to build up of mineral deposits. Heat exchangers must only be serviced by a qualified technician, as acid cleaning and special pumping equipment may be required.

Figure 5: Typical Open Loop Application

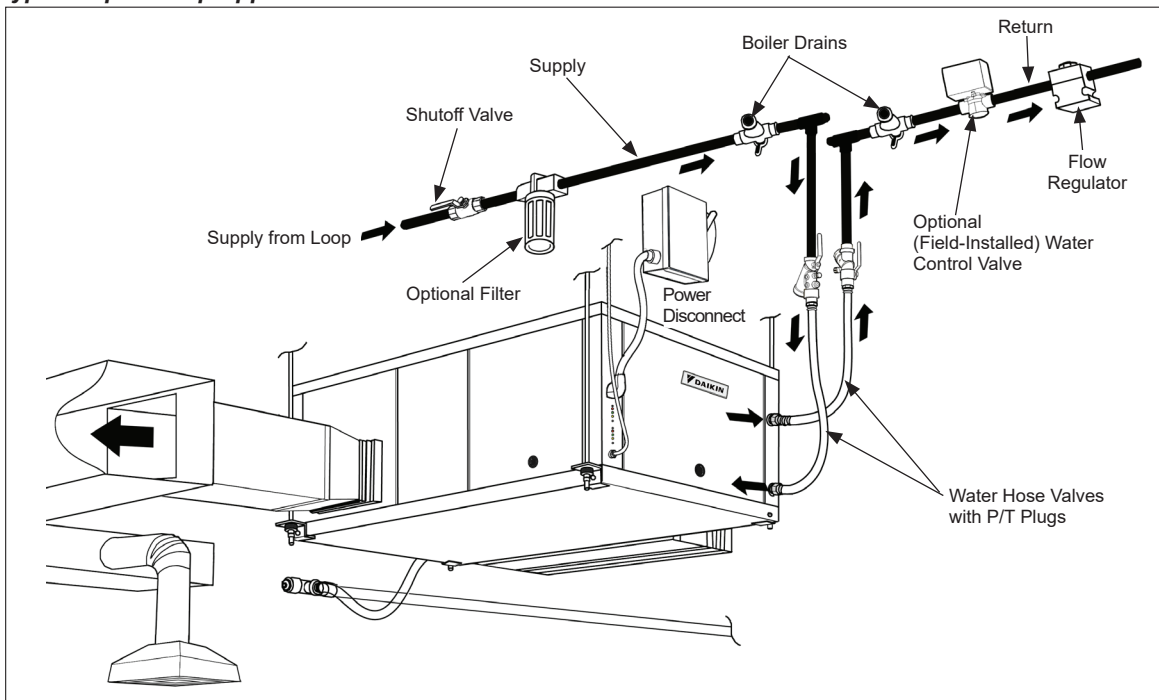

Water Quality Standards - [Table 8](#), "Water Quality Conditions and Applications" on [page 14](#) should be consulted for water quality requirements. Scaling potential should be assessed using the pH/Calcium hardness method. If the pH < 7.5 and the calcium hardness is less than 100 ppm, scaling potential is low. If this method yields numbers out of range of those listed, the Ryznar Stability and Langelier Saturation indices should be calculated. Use the appropriate scaling surface temperature for the application, 150°F [66°C] for direct use (well water/open loop); 90°F [32°F] for indirect use. A monitoring plan should be implemented in these probable scaling situations. Other water quality issues such as iron fouling, corrosion prevention and erosion and clogging should be referenced in [Table 8 on page 14](#).

Expansion Tank and Pump - Use a closed, bladder type expansion tank to minimize mineral formation due to air exposure. The expansion tank should be sized to provide at least one minute continuous run time of the pump using its draw-down capacity rating to prevent pump short cycling. Discharge water from the unit is not contaminated in any manner and can be disposed of in various ways, depending on local building codes (e.g. recharge well, storm sewer, drain field, adjacent stream or pond, etc.). Most local codes forbid the use of sanitary sewer for disposal. Consult your local building and zoning department to assure compliance in your area.

Water Control Valve (Factory or field-installed option) - Note the placement of the water control valve in [Figure 5 on page 12](#). Always maintain water pressure in the heat exchanger by placing the water control valve(s) on the return line to prevent mineral precipitation during the off-cycle. Pilot operated slow closing valves are recommended to reduce water hammer. If water hammer persists, a mini-expansion tank can be mounted on the piping to help absorb the excess hammer shock. If a field provided motorized valve and actuator is utilized, ensure that the total 'VA' draw of the valve can be supplied by the unit transformer. For instance, a slow closing valve can draw up to 35VA. Units are furnished with a factory-installed 50 VA transformer. An optional 75VA transformer is also available. A typical pilot operated solenoid valve draws approximately 15VA (see [Figure 39 on page 53](#)).

Flow Control - Flow control can be accomplished by two methods. One method involves simply adjusting the field-provided ball valve or flow control valve on the return line. Measure the pressure drop through the unit heat exchanger, and determine flow rate from [Table 7](#). Since the pressure is constantly varying, two pressure gauges may be needed. Adjust the valve until the desired flow of 1.5 to 4 gpm, per ton [5.7 to 15.1 l/m, per kW] is achieved. A second method of flow control requires a flow control device mounted on the outlet of the flow control valve. This device is typically a brass fitting with an orifice of rubber or plastic material that is designed to allow a specified flow rate. On occasion, flow control devices may produce velocity noise that can be reduced by applying some back pressure from the ball valve located on the discharge line. Slightly closing the valve will spread the pressure drop over both devices, reducing the velocity noise.

Table 7: Water Pressure Drop

Unit Size	GPM	Pressure Drop, FOH
007	1.2	1.0
	1.8	1.9
	2.3	2.8
009	1.5	1.4
	2.3	2.8
	3.0	4.3
012	2.0	2.8
	3.0	5.2
	4.0	8.2
015	2.5	3.5
	3.8	6.9
	5.0	10.8
019	3.2	6.7
	4.8	11.8
	6.3	17.4
024	4.0	5.2
	6.0	10.0
	8.0	15.8
030	5.0	7.5
	7.5	14.3
	10.0	22.6
036	6.0	6.1
	9.0	12.0
	12.0	19.3
042	7.0	7.9
	10.5	15.5
	14.0	24.9
048	8.0	5.0
	12.0	10.6
	16.0	18.0
060	10.0	4.7
	15.0	10.5
	20.0	18.6
070	11.7	5.2
	17.5	13.2
	23.3	25.8

Water System Quality

The cleaning, flushing and chemical treatment of a water source heat pump system is fundamental to efficient operation and the life expectancy of the system.

Potential system problems produced by the use of water fall into three general categories:

1. **Scale formation** – Mineral deposits which result from the crystallization and precipitation of dissolved salts in the water. The deposits form an insulating barrier, reducing the heat transfer rate and impeding the circulation of fluids due to increased pressure drop.
2. **Corrosion** – Decomposition of the metal caused by absorption of gases from the air. Corrosion may occur in any metal component of the system.
3. **Organic growths** – Slime and algae which form under certain environmental conditions, and can reduce the heat transfer rate by forming an insulating coating or can promote corrosion by pitting.

The system water should be evaluated for degrees of impurity, with testing available from independent testing labs, health departments or state agencies.

Table 8 is a list of water characteristics, the potential impurities and their results and the recommended treatment.

Avoiding Potential Problems

As shown in Table 8, all water contains some degree of impurities which may affect the performance of a heat pump system. The use of a cupro-nickel coil can help avoid potential problems. Water flow rates should:

- Be high enough that the temperature rise through the heat exchanger does not exceed 12° F when operating in the cooling mode.
- Not exceed 4 GPM per nominal ton. Flow rates that have velocities of 10 feet per second or more may cause pipe erosion and heat exchanger failure.

Table 8: Water Quality Conditions and Applications

Potential Problem	Chemical(s) or Condition	Range for Copper Heat Exchangers	Range of Cupronickel Heat Exchanger
Scaling	Calcium & Magnesium Carbonate	Less than 350 ppm	Less than 350 ppm
Corrosion	pH Range	7 – 9	5 – 9
	Total Dissolved Solids	Less than 1000 ppm	Less than 1500 ppm
	Ammonia, Ammonium Hydroxide	Less than 0.5 ppm	Less than 0.5 ppm
	Ammonium Chloride, Ammonium Nitrate	Less than 0.5 ppm	Less than 0.5 ppm
	Calcium Chloride/ Sodium Chloride	Less than 125 ppm	Less than 125 ppm - Note 4
	Chlorine	Less than 0.5 ppm	Less than 0.5 ppm
	Hydrogen Sulfide	None Allowed	None Allowed
Biological Growth	Iron Bacteria	None Allowed	None Allowed
	Iron Oxide	Less than 1 ppm	Less than 1 ppm
Erosion	Suspended Solids	Less than 10 ppm	Less than 10 ppm
	Water Velocity	Less than 8 ft./s	Less than 12 ft./s

Notes: 1. Water hardness in ppm is equivalent to hardness in mg/L.

2. Grains/gallon = ppm divided by 17.1.

3. Copper and cupronickel heat exchangers are not recommended for pool applications for water outside the range of the table. Secondary heat exchangers are required for applications not meeting the requirements shown above.

4. Salt water applications (approx. 25,000 ppm) require secondary heat exchangers due to copper piping between the heat exchanger and the unit fittings.

Supply & Return Piping

Pre-Installation Considerations

All units should be connected to supply and return piping in a two-pipe reverse return configuration. A reverse return system is inherently self-balancing and requires only trim balancing where multiple quantities of units with different flow and pressure drop characteristics exist in the same loop.

A direct return system may also work acceptably, but proper water flow balancing is more difficult to achieve and maintain.

- The piping can be steel or copper.

⚠ WARNING

Polyolester Oil, commonly known as POE oil is a synthetic oil used in many refrigeration systems, and may be present in this Daikin product. POE oil, if ever in contact with PVC/CPVC will coat the inside wall of PVC/CPVC pipe causing environmental stress fractures. Although there is no PVC/CPVC piping in this product, please keep this in mind when selecting piping materials for your application, a piping system failure and property damage could result.

Supply and return runouts usually join the unit via short-lengths of high pressure flexible hose which are sound and vibration isolators for both unit operating noise and hydraulic pumping noise.

- One end of the hose should have a swivel fitting to facilitate removal for service.

Note: *Hard piping is not recommended since no vibration or noise attenuation can be accomplished.*

Figure 6: Flexible Hose Kit #7

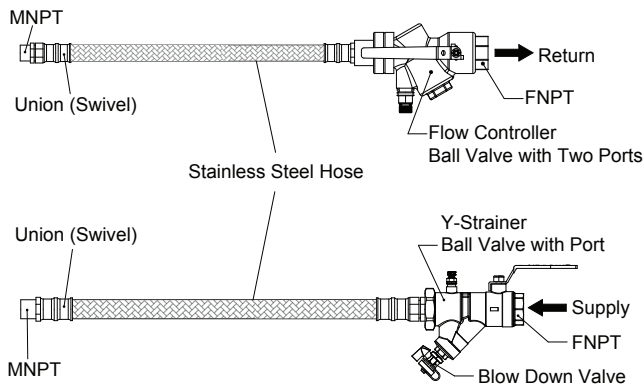
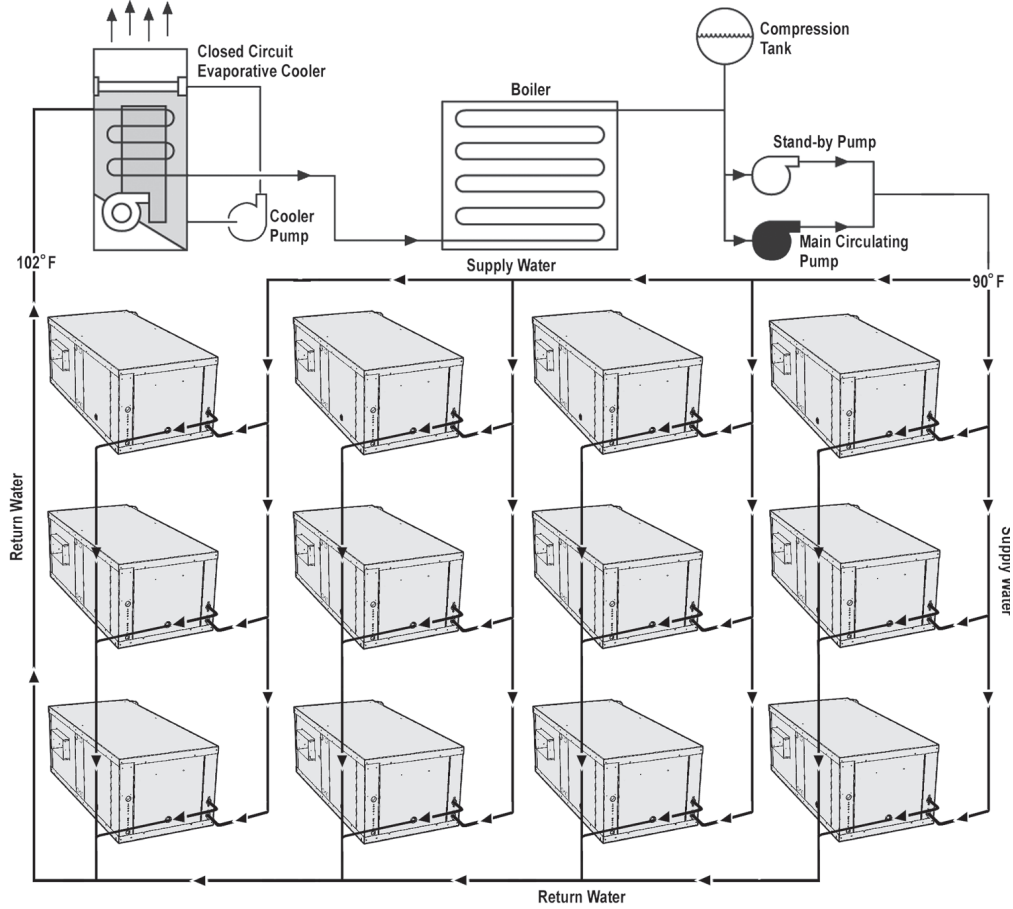

Figure 7: Example of A Reverse Return Piping System



Installation Considerations

1. Locate the unit in an area that allows for easy removal of the filter and access panels. Leave a minimum of 18" of clearance around the heat pump for easy removal of the entire unit (if necessary), and to perform routine maintenance, or troubleshooting. Provide sufficient room to make water, electrical and duct connections.
2. The contractor should make sure that adequate ceiling panel access exists, including clearance for hanger brackets, duct collars and fittings at water and electrical connections.
3. Allow adequate room below the unit for a condensate trap and do not locate the unit above pipes.
4. Each unit is suspended from the ceiling by four threaded rods. The rods are attached to the unit corners by a hanger bracket through a rubber isolator.

⚠ CAUTION

Do not use rods smaller than shown in [Figure 8](#). The rods must be securely anchored to the ceiling or to the bar joists.

5. Each unit is furnished with a hanger kit. The hanger brackets are assembled to the unit. The rubber isolators, washers, bolts and lock washers are shipped and packed with the unit. Lay out the field-provided threaded rods per the dimension in [Table 9](#).
6. When attaching the hanger rods to the unit, a double nut is recommended since vibration could loosen a single nut. The installer is responsible for providing the hex nuts when installing hanger rods.

Figure 8: Hanger Bracket Detail - Sizes 007 Through 070

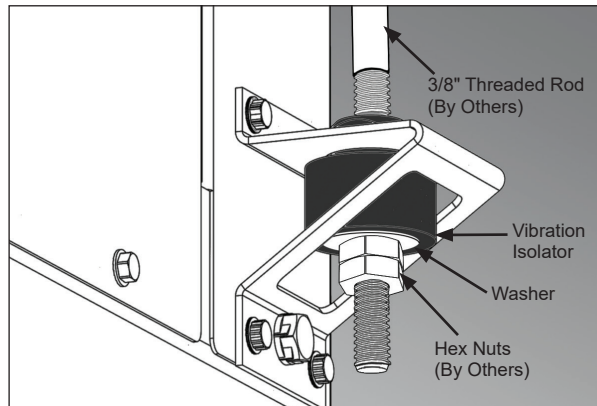

7. Make sure the unit is installed level and leave a minimum 3" (76 mm) extra threaded rod below the double nuts or minimum 3" (76 mm) clearance between top of unit and ceiling above to facilitate top panel removal for servicing.
8. Remove all shipping blocks from the fan wheel, ([Figure 10](#)).

Hanger Bracket Locations

Figure 9: Hanger Bracket Locations Dimensions - Sizes 007 Through 070

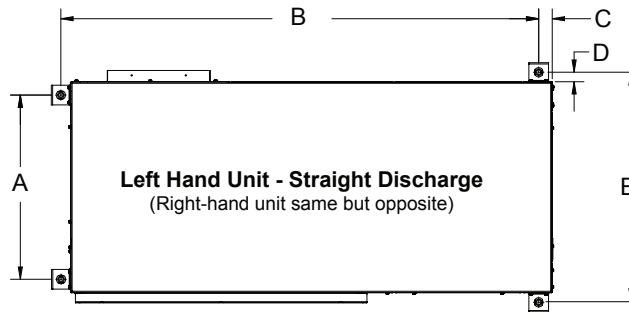

Table 9: Hanger Brackets Dimensions

Unit Size	Dimensions - inches (mm)				
	A	B	C	D	E
007, 009, 012	16.8	33.6	1.1	1.0	20.9
015, 019	16.2	41.6	1.4		21.9
024, 030	17.2	42.6			23.4
036	18.7	48.6			25.9
042		53.6			
048	21.2	64.6			
060					
070					

Figure 10: Remove Foam Shipping Block From Fan Housing and Hardware Box, Applied Based on Fan Configuration

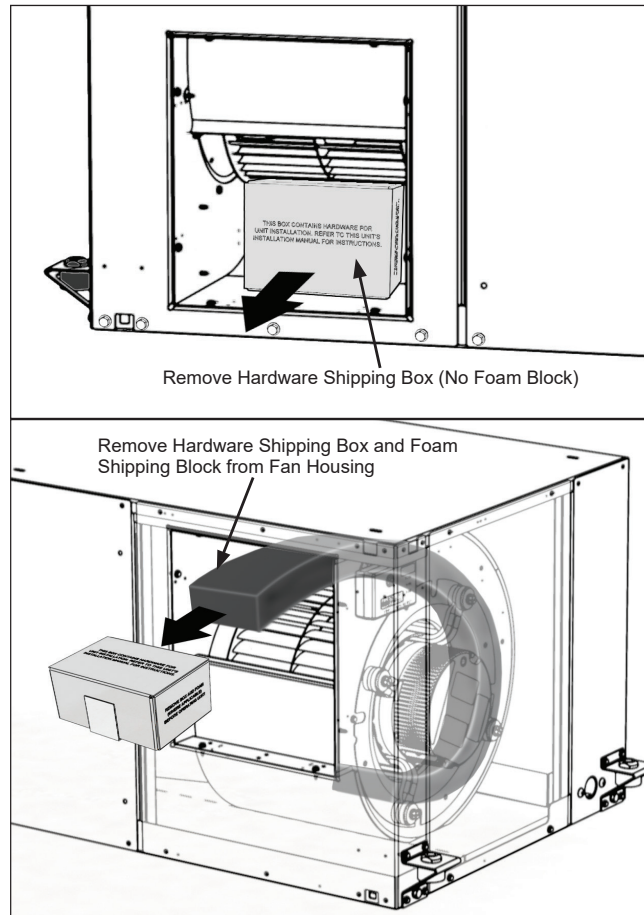

Figure 11: Recommended Clearances for Service Access

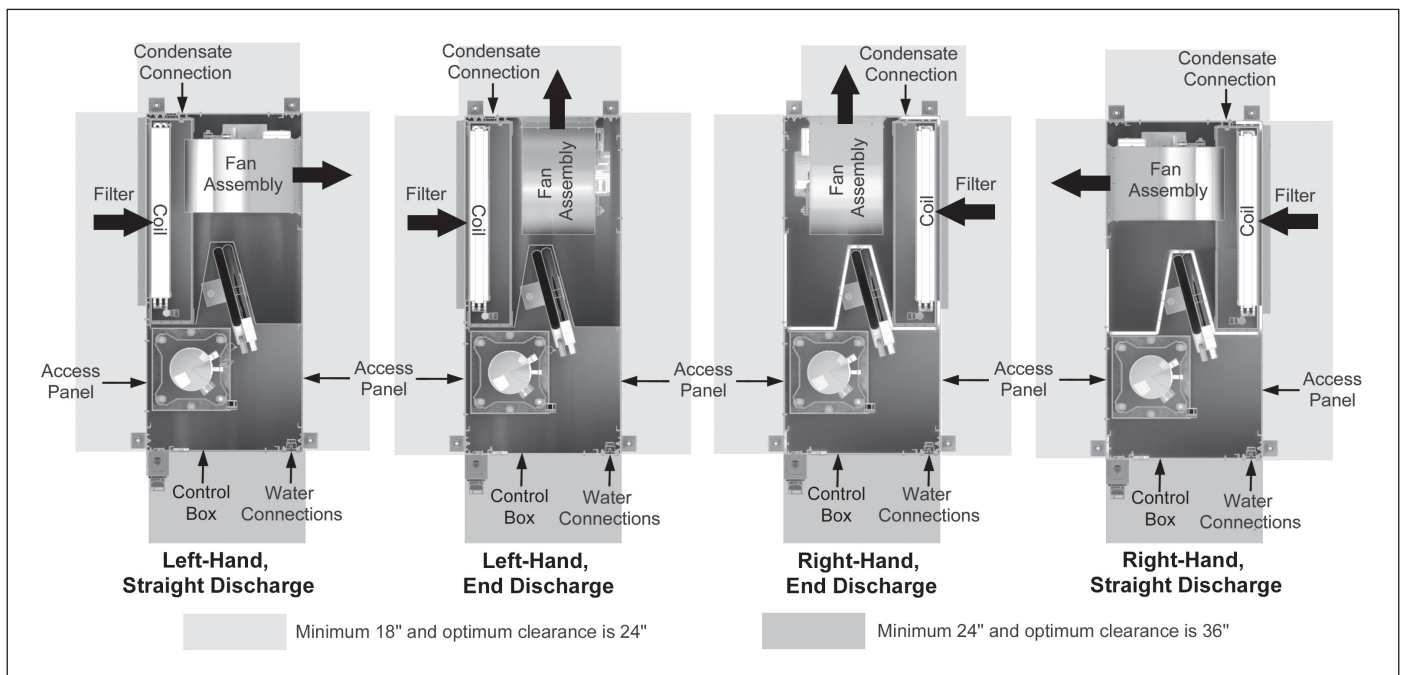
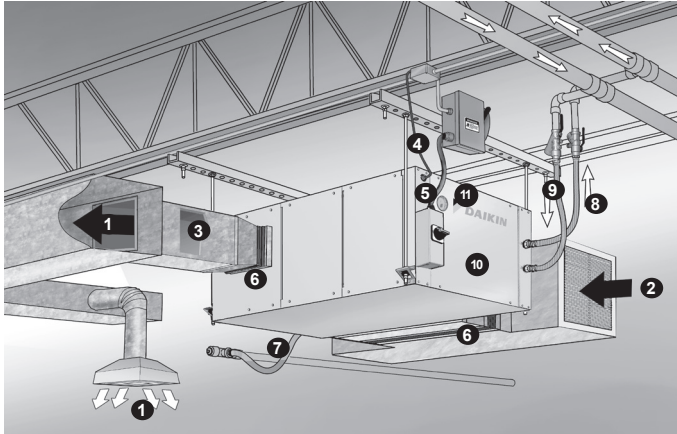

Figure 12: Horizontal Unit - Typical Installation In Ceiling



1. Discharge air
2. Return air
3. Acoustic thermal duct lining - 10 feet
4. Low voltage wiring to unit control box
5. Line voltage to optional non-fused disconnect switch
6. Flexible duct collar(s)
7. Condensate drain with trap
8. Flexible, braided, stainless steel return hose with flow controller/ball valve with port
9. Flexible, braided, stainless steel supply hose with Y-strainer/ball valve with port
10. Access to unit control box
11. LED annunciator lights sight glass to view unit operation

⚠ WARNING

Clearance should be maintained to meet local and national code requirements.

Discharge Air Conversion

A straight discharge unit may be converted to an end discharge by doing the following:

Note: *The information covered in this section of the blower assembly orientation is typical of Daikin units. Regardless, if you are changing end to straight or straight to end the blower assembly has to turn 90 degrees and simultaneously rotate 180 degrees to achieve the proper orientation. Not all Daikin units will have the same air discharge location but will have the same general results when following the instructions.*

⚠ DANGER



Hazardous Voltage! Disconnect all electric power including remote disconnects before servicing. Failure to disconnect power before servicing can cause serious injury or death.

⚠ CAUTION

Sharp edges can cause minor injury. Avoid contact with them.

4. Perform conversion prior to installing the unit.
5. Remove the bolts securing the hanger bracket as indicated in Figure 13. Remove the (8) screws around the perimeter of the panel and fan assembly.

Note: *Retain all screws for reinstalling.*

3. Disconnect power wiring from the fan motor. EC motors will require removal of control wire plug.
4. Lift the fan assembly out rotating it 180 degrees and position it within the opening at the end of the unit. The fan motor should be accessible through the available access panel when installed properly.
5. Secure the fan assembly to the unit frame with the screws removed previously.
6. Reinstall the access panel in the fan motor access opening (Figure 13).

Ductwork and Attenuation

Discharge duct shall be used with these units. Where return air ductwork is required, the unit comes standard with a 1" thick, factory-installed disposable filter, mounted in a 2-sided filter rack. The filter can be easily removed from either side. A 2" deep 4-sided, gasketed filter rack is available as a factory-installed option to accept a 2" Merv 8 filter. Also available a 4" deep, 4-sided, gasketed filter rack with a 4" Merv 13 filter.

All ductwork should conform to industry standards of good practice as described in ASHRAE Systems Guide.

A field supplied discharge duct system will normally consist of:

- a flexible connector at the unit
- a 10 foot length of insulated duct
- and a trunk duct teeing into a branch circuit with discharge diffusers

Figure 13: Converting Discharge Air

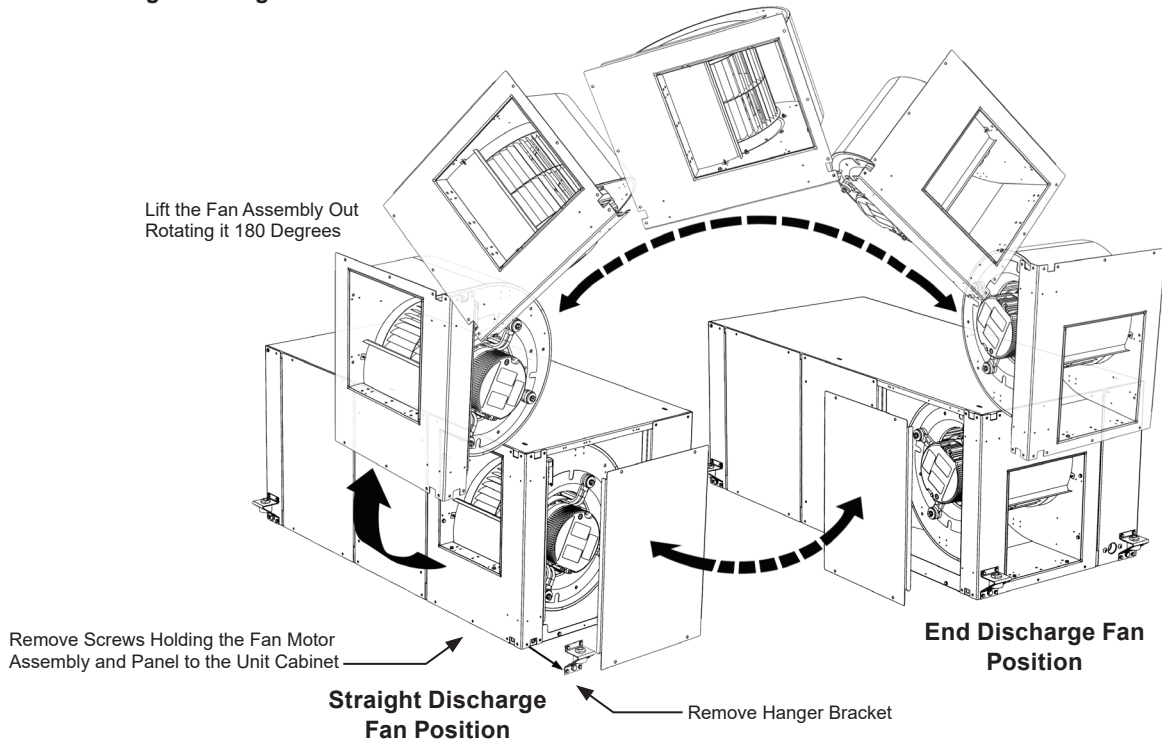
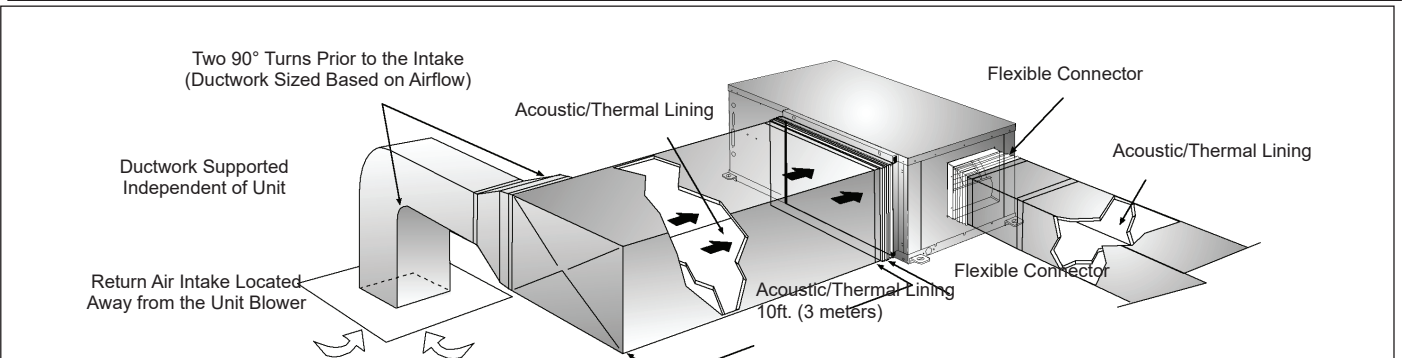
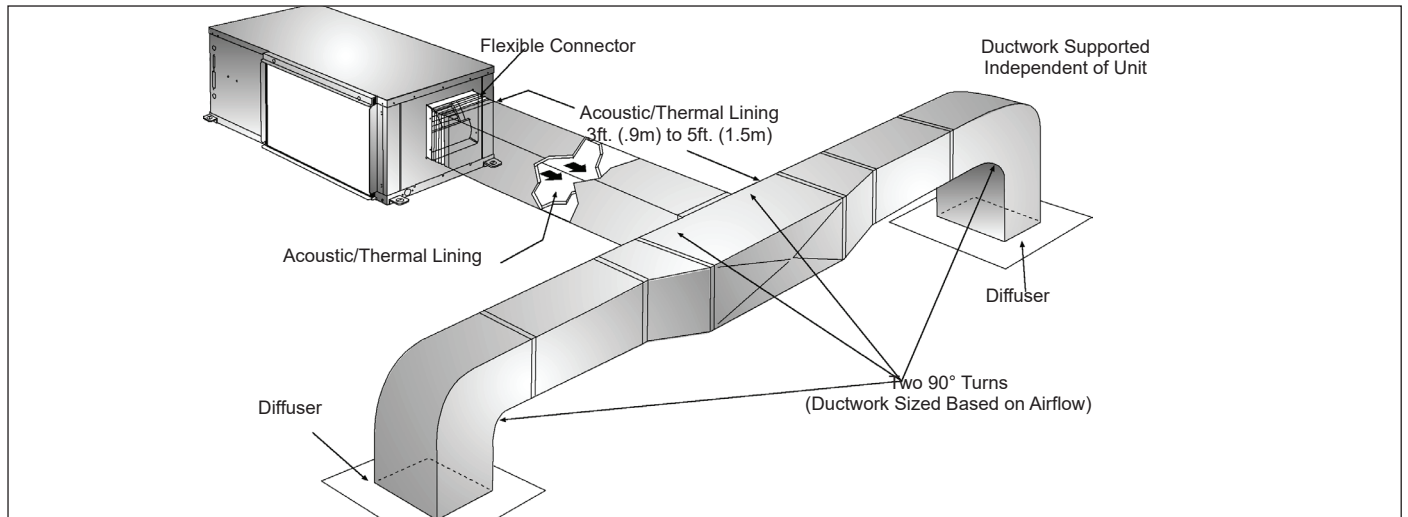

Figure 14: Typical Ducting for Horizontal Unit



- Notes:**
1. Transformation to supply duct have maximum slope of 1" in 7".
 2. Square elbows with double thickness vanes may be substituted.
 3. Do not install ducts so that the air flow is counter to fan rotation. If necessary, turn fan section.
 4. Transformations and units must be adequately supported so no weight is on the flexible fan connection.

Air Duct Connections

1. Bend the perforated supply and return air duct flanges out 90 degrees with wide duct pliers. **Bend Duct Flanges Out 90 Degrees**

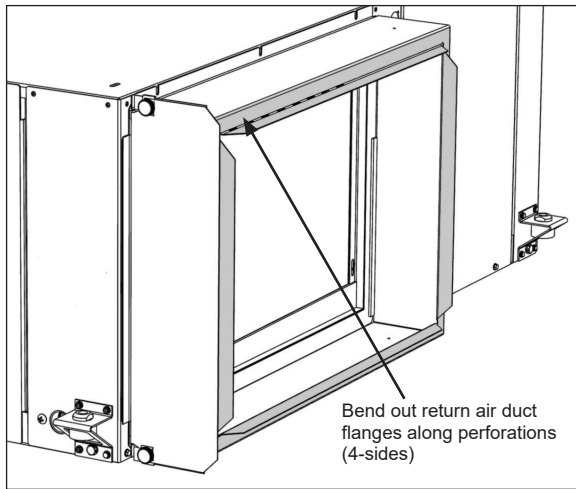

Note: *It is recommended that a field supplied flexible (boot) connector is attached to the flanges to isolate vibration. See Figure 14.*

2. Connect the flexible boot connector and duct to the flanges. Screws used to secure supply duct should be inserted in the duct flange only.

Note: *Screws should not be installed through the unit cabinet. Installation of screws through the unit cabinet may contact with refrigerant piping voiding warranty. The unit cabinet should not be cut or altered for installation of accessories.*

WARNING

If for any reason the perforated supply or return duct flanges are not required they must be bent out 90 degrees or removed.

Installation - GCH Horizontal Unit

Filter Rack, Return Duct Collar Dimensions

Figure 15: Filter Rack, Return Duct Collar Dimensions

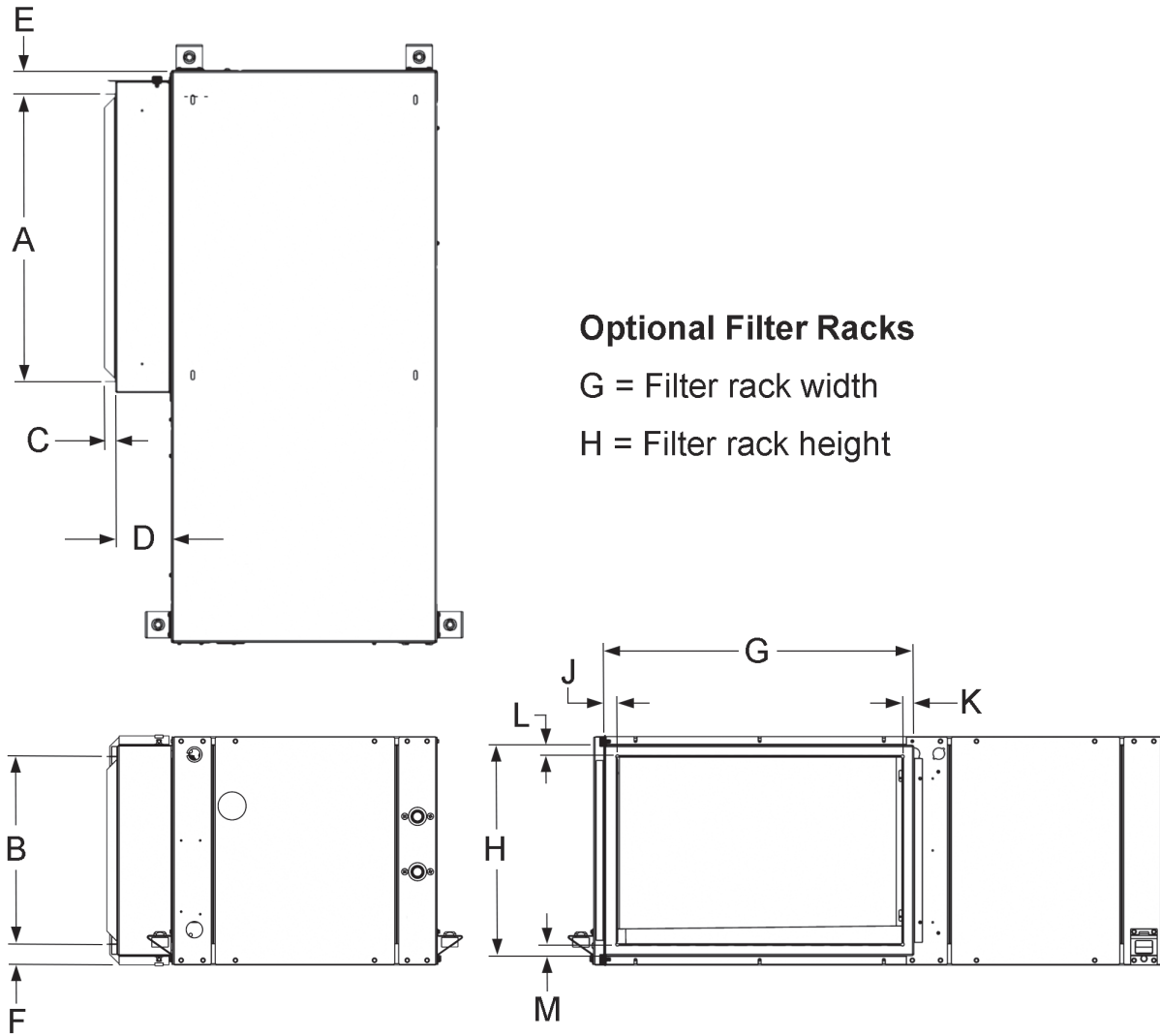

Table 10: Letter Dimensions for Figure 15

Unit Size	*A	*B	C	D		E	F	G	H	*J	*K	*L	*M
				2-inch	4-inch								
007, 009, 012	16.2	8.5	0.9	2.2	4.2	1.7	1.5	17.9	10.0	1.0	0.8	0.8	0.8
015, 019	22.2	14.1	0.9	2.2	4.2	1.7	1.5	23.9	15.6	1.0	0.8	0.8	0.8
024, 030	21.7	14.4	0.9	2.2	4.2	1.7	1.5	23.4	15.9	1.0	0.8	0.8	0.8
036	27.2	16.1	0.9	2.2	4.2	1.7	1.5	28.9	17.6	1.0	0.8	0.8	0.8
042	27.2	16.1	0.9	2.2	4.2	1.7	1.5	28.9	17.6	1.0	0.8	0.8	0.8
048	31.4	18.1	0.9	2.2	4.2	1.7	1.5	33.2	19.6	1.0	0.8	0.8	0.8
060	31.4	18.1	0.9	2.2	4.2	1.7	1.5	33.2	19.6	1.0	0.8	0.8	0.8
070	44.3	18.1	0.9	2.2	4.2	1.7	1.5	45.7	19.6	1.0	0.8	0.8	0.8

Notes: *Filter rack flange dimensions are to the outside edge of the flange when bent out to 90 degrees at perforations. Dimensions are approximate and dependent on degree of bend.

Discharge Air Duct Collar Connections

Figure 16: GCH Discharge Air Duct Collars Locations and Dimensions

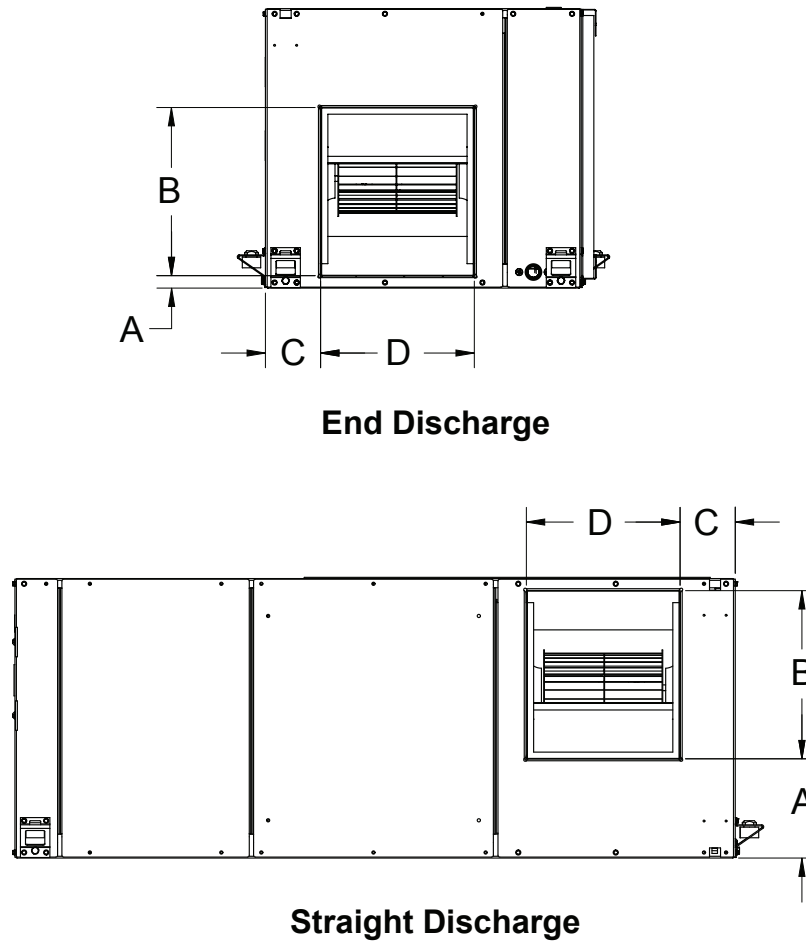

Table 11: Discharge Duct Collar Letter Dimensions for Figure 16.

Unit Size	End Discharge				Straight Discharge			
	A	B	C	D	A	B	C	D
007, 009, 012	5.3	4.9	3.0	9.4	1.3	4.9	3.0	9.4
015, 019	1.0	10.4	3.0	9.3	5.6	10.4	2.9	9.3
024, 030	1.1	10.4	3.4	9.3	5.8	10.4	3.4	9.3
036	1.4	10.4	4.4	9.3	7.3	10.3	4.4	9.2
042	0.8	11.4	3.8	10.4	6.7	11.4	3.8	10.4
048	3.0	11.4	5.3	10.4	6.7	11.4	5.3	10.4
060	2.4	13.6	4.5	13.1	5.0	13.6	4.5	13.1
070	2.4	13.6	6.4	13.1	5.0	13.6	6.4	13.1

Notes: 1. Filter rack flange dimensions are to the outside edge of the flange.

* Unit size 070 uses two (2) filters when standard filters are selected, where dimension "X" (height) = the overall outside edge dimension.

Electrical Connections

Figure 17: Horizontal Unit Electrical Locations

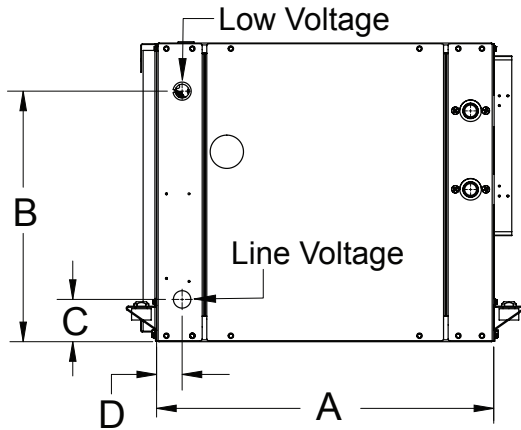

Table 12: GCH Electrical Connections Locations

Unit Size	A Unit Width	B	C	D
007, 009, 012	18.9	10.4	2.7	1.6
015, 019		15.7		
024, 030	19.9	15.9	2.7	
036	21.4			
042	23.9	17.7	2.7	
048				
060				
070				

Table 13: Operating Voltages

Voltage	Minimum	Maximum
115/60/1	103	126
208-230/60/1	197	253
265/60/1	238	292
208-230/60/3	197	253
460/60/3	414	506
575/60/3	515	632

Notes: 1. Three-phase system imbalance shall not exceed 2%.
 2. Use a short length of flexible conduit at the unit connection to minimize and isolate vibration to the building. All conduit should be supported to avoid contact with unit cabinet or immediate building structure to prevent unnecessary noise.

⚠ WARNING

All field installed wiring must comply with local and national electrical codes. This equipment presents hazards of electricity, rotating parts, sharp edges, heat and weight. Failure to read and follow these instructions can result in property damage, personal injury or death. This equipment must be installed by experienced, trained personnel only.

⚠ CAUTION

Fasteners should not be screwed into and penetrate the unit enclosure to avoid damage to internal electrical and mechanical components.

⚠ WARNING

Use copper conductors only. Conductors must be minimum 75°C.

⚠ CAUTION

All electrical connections should be inspected for tightness as they may come loose during shipment.

230 Volt Operation

All 208-230 volt single-phase and three-phase units are factory wired for 208 volt operation. To convert to 230 volt operation, the RED line voltage wire from the 24 volt transformer must be changed.

- Disconnect the RED transformer wire at the contactor and replace with the orange wire, [Figure 18](#).

Figure 18: For 230 Volt Operation, Disconnect the RED transformer wire at the contactor and replace with the orange wire

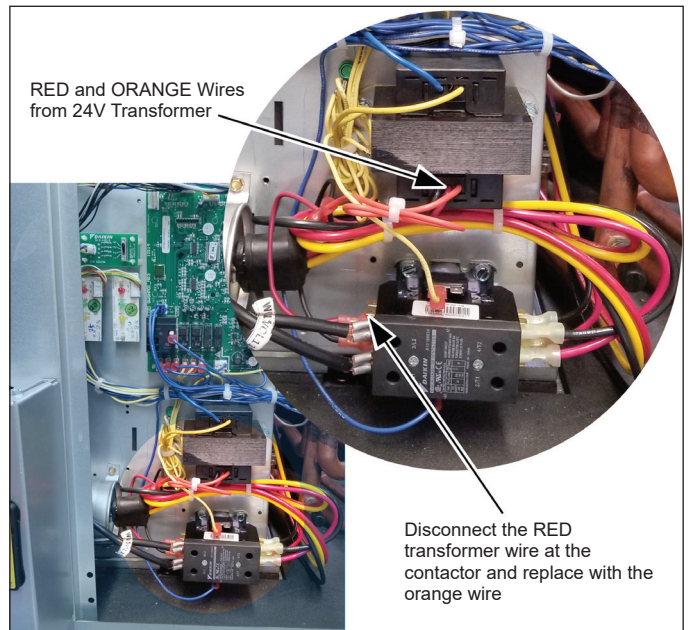

Line Voltage – 208-230, 460, 575V

⚠ DANGER

LOCKOUT/TAGOUT all power sources prior to wiring or servicing the unit. Hazardous voltage can cause serious injury or death. Disconnect electric power before servicing equipment. More than one disconnect may be required to de-energize the unit.

1. Route line voltage supply wiring through the lower 1-1/8" diameter knockout in the left corner post.
2. Wires should extend through the lower left side of the control box. Route wires through wire ties where provided.
3. Remove and discard the factory provided stripped wire leads from the left side unit contactor screw terminals (not shown).
4. Connect the field supplied wires to the left side contactor screw terminals as shown in [Figure 19](#).
5. Connect ground wire to provided (green) ground screw
6. Twist neutral wires and wire nut (460V units only)

Figure 19: Route Line Voltage Wires To Terminal Screws

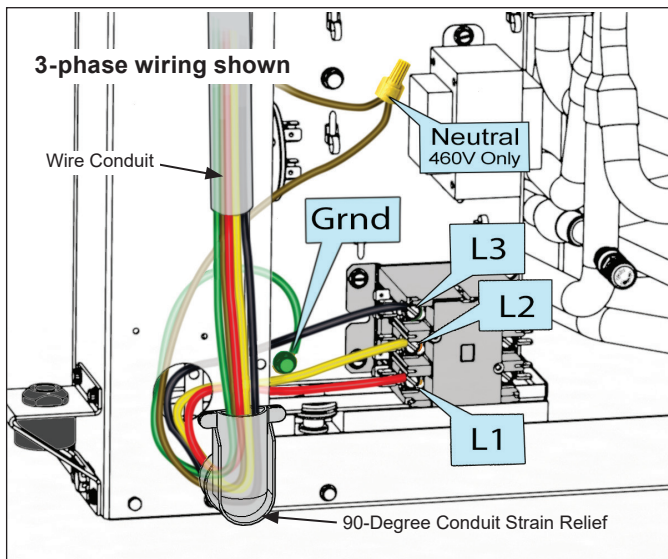

Note: Units without constant EC motor will not include a neutral conductor. For clarity, not all unit wires are shown in the unit line voltage connection area.

Line Voltage – 115V

⚠ DANGER

LOCKOUT/TAGOUT all power sources prior to wiring or servicing the unit. Hazardous voltage can cause serious injury or death. Disconnect electric power before servicing equipment. More than one disconnect may be required to de-energize the unit.

1. Route line voltage supply wiring through the lower

1-1/8" diameter electrical knockout in the left corner post.

2. Connect the field supplied wires to the left side contactor screw terminals as shown in [Figure 20](#).
3. Secure ground wire to (green) ground screw.

Figure 20: Line Voltage Wiring Route To Wire Connections

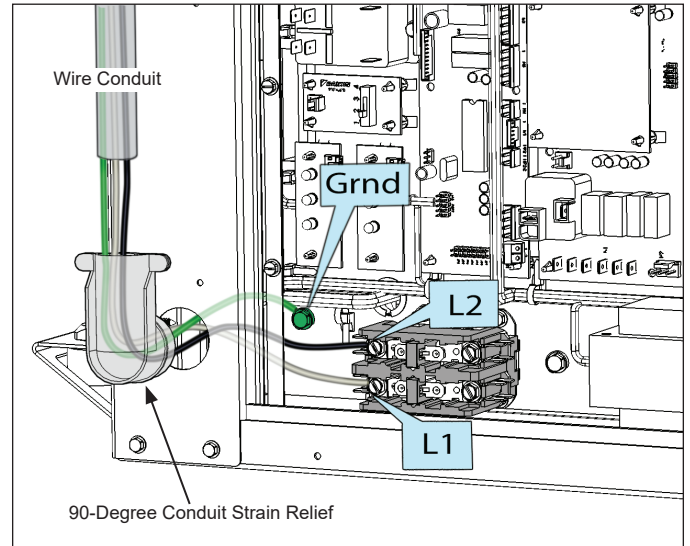

GCH Unit With Non-Fused Disconnect Switch

Figure 21: Optional Non-Fused Disconnect Switch Location and Dimensions

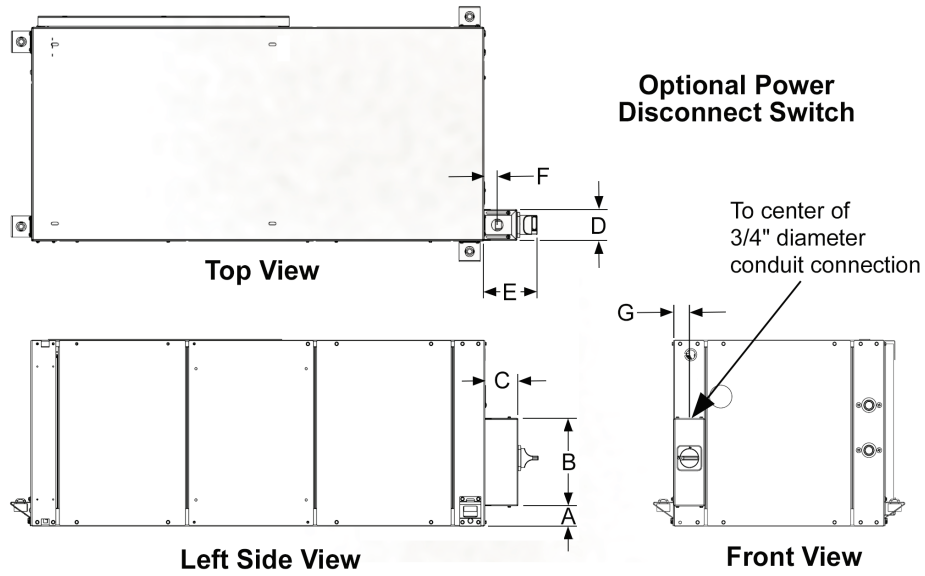

Unit Size	A	B	C	D	E	F	G
007, 009, 012	1.7	8.1	3.1	2.9	5.1	1.3	1.5
015, 019, 024, 030, 036	1.9	8.1	3.1	2.9	5.1	1.3	1.5
042, 048, 060, 070	1.9	8.1	3.1	2.9	5.1	1.3	1.5

Line Voltage Electrical Connections With Disconnect – 115-575V

⚠ DANGER

LOCKOUT/TAGOUT all power sources prior to wiring or servicing the unit. Hazardous voltage can cause serious injury or death. Disconnect electric power before servicing equipment. More than one disconnect may be required to de-energize the unit.

When units are equipped with the optional non-fused disconnect switch, the line voltage supply is brought in through the top of the junction box. Disconnect location and dimension details are provided in [Figure 22](#).

Note: 1. The disconnect location may vary depending on the return air handling. See [Figure 22](#). Right-hand unit shown, with switch mounted on the opposite corner post from return air.
 2. 460V units with constant CFM EC motor require a neutral conductor. See number bubble “6” in [Figure 22](#).

1. Remove screws from the top and bottom locations on the disconnect switch cover.
2. These are the factory-installed wires from the switch to the line voltage terminals in the unit control box.
3. Connect wires to the upper unused terminals.
4. Tighten terminal screws to secure wires.
5. Connect ground wire to provided green ground screw.
6. Connect field provided neutral conductor.
 (*constant CFM EC motors only)

Replace cover and secure with screws.

Figure 22: 460V Wiring With Neutral Wire (*Constant CFM EC Motors Only) To The Non-Fused Disconnect Switch

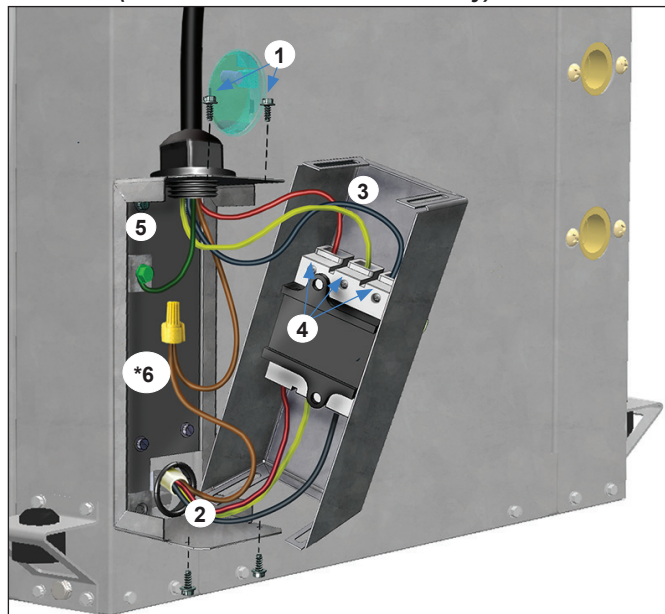

Low Voltage Wire Connections

Notes: 1. Never install relays coils in series or parallel with the thermostat inputs.

2. Units equipped with dehumidification and using thermostat control require installation of a factory supplied return air sensor connected to H9 terminal. See [Figure 26 on page 30](#) for details.

1. Route the field-supplied low voltage wiring through the upper knockout in the left corner post as shown in [Figure 23](#).
2. Secure the low voltage wire connections to the terminals as shown in [Figure 23](#), [Figure 24](#) and [Figure 25](#). Refer to [Figure 28 on page 31](#) for I/O Expansion Module terminal TB1-1 connection.

Figure 23: Terminal Connections To TB2 (Thermostat Control) On The MTIII Board

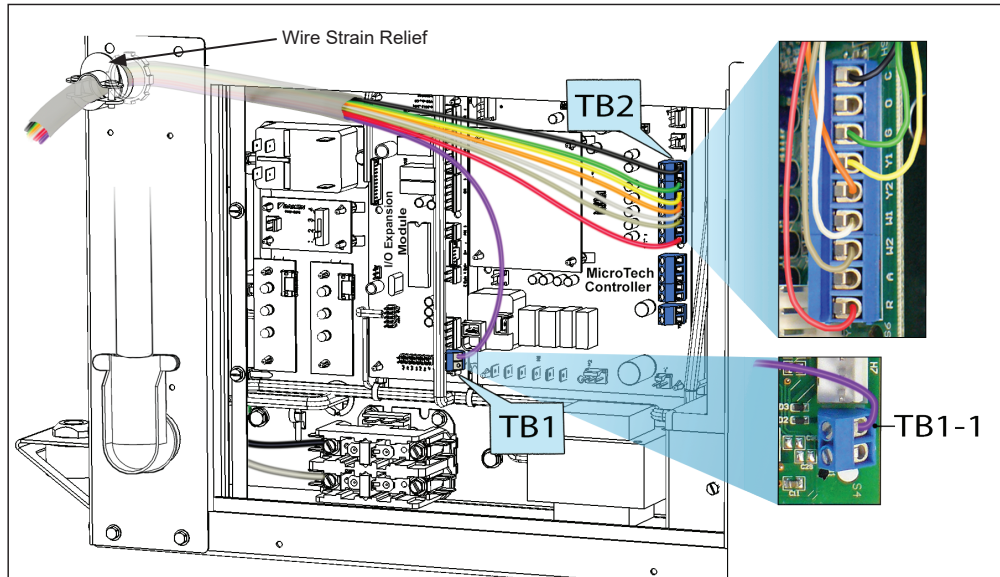

Figure 24: Terminal Connections To TB2 (Thermostat Control) On The MTIII Board

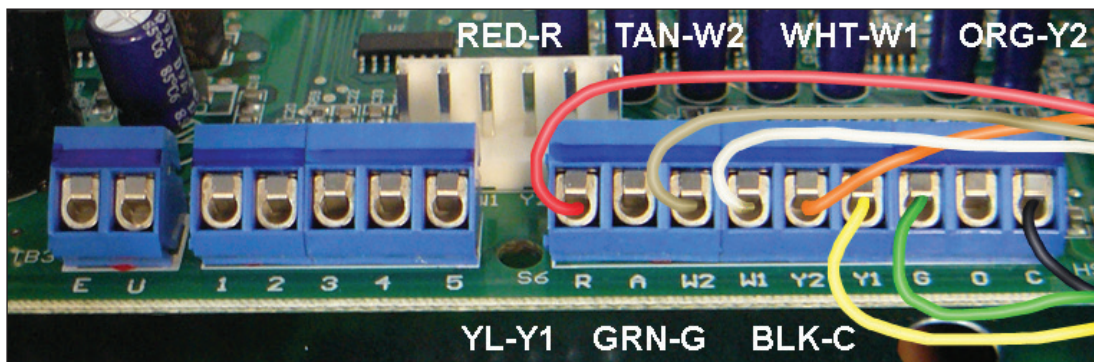
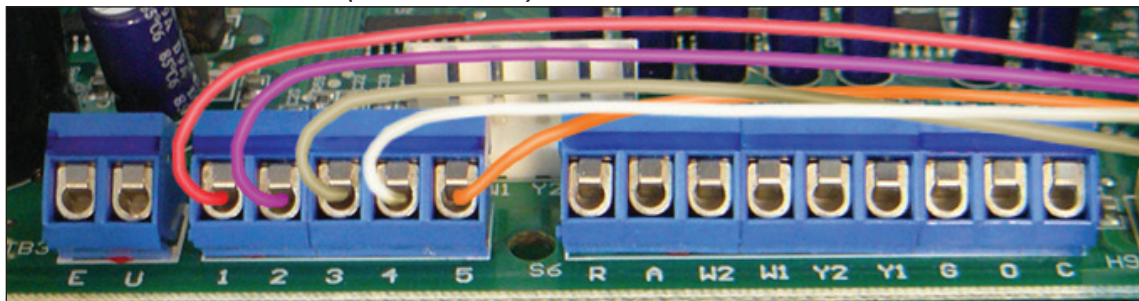
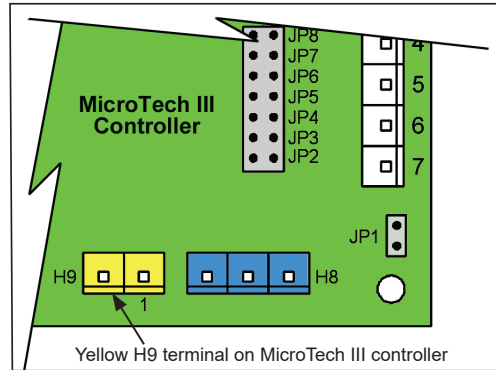
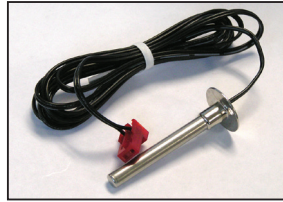

Figure 25: Terminal Connections To TB1 (Sensor Control) On The MTIII Board



Typical Connections For Thermostats & Temperature Sensors Applications

Figure 26: Units Equipped with Dehumidification and Thermostat Control. Factory Supplied Return Air Sensor Connects To H9 Terminal.



Return Air Temperature Sensor (RAT) locations

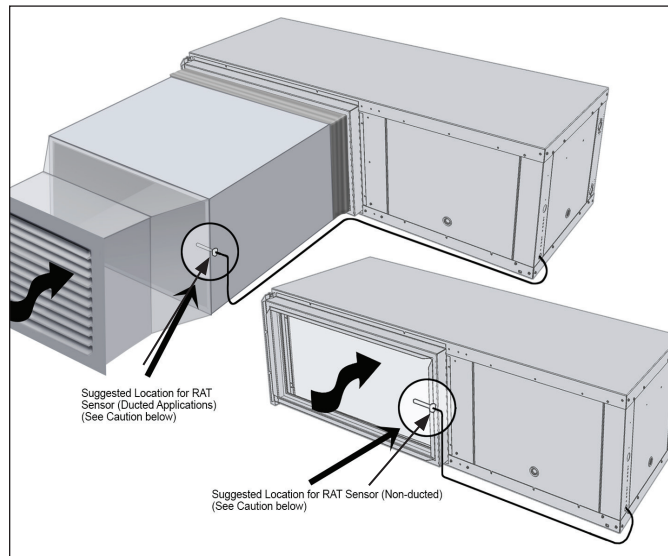

⚠ CAUTION

When an optional wall-mounted room temperature sensor is connected to the unit controller, the Return Air Temperature (RAT) sensor must not be installed. A wall-mounted room temperature sensor and the return air temperature sensor must not be connected simultaneously or the unit will not operate properly.

Note: For single stage operation wire Y1 from thermostat to Y2 terminal on the Microtech III control board.

Figure 27: Digitally Adjustable Room Temperature Sensor Wiring

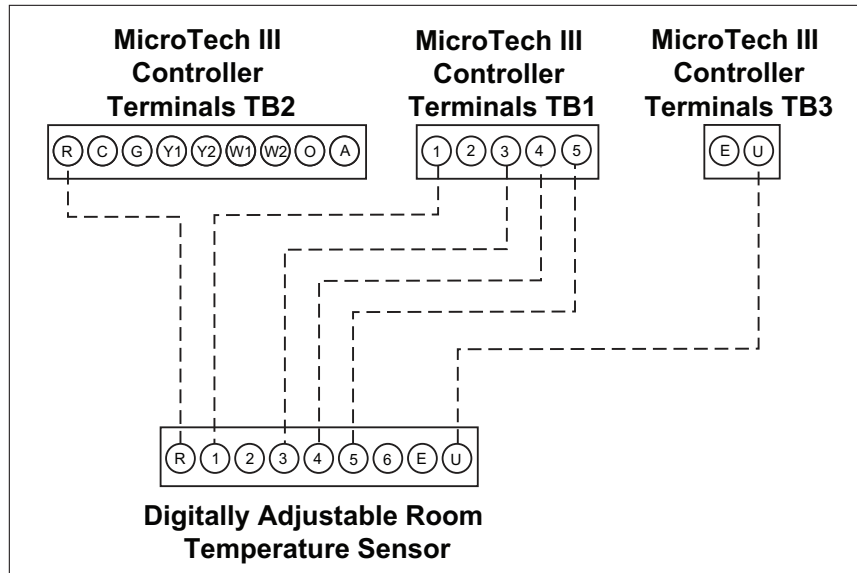
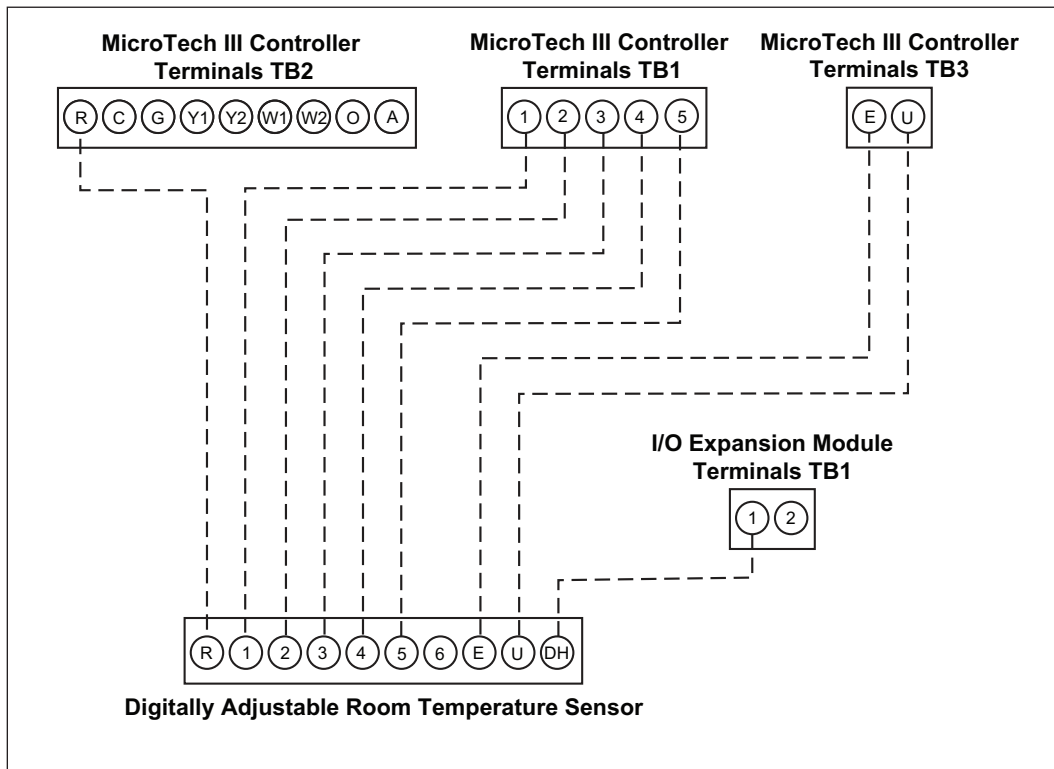

Figure 28: Digitally Adjustable Room Temperature and Humidity Sensor Wiring



Note: Terminal TB1-1 is used for optional dehumidification operation.

Table 14: Thermostats and Remote Indoor Sensor









Wall Mounted Thermostats & Remote Sensor for use with all WSHP units: Console, V-Stack, Enfinity & SmartSource models		Thermostats				Remote Sensor
		Non-Programmable	Programmable (7 Day or 5+1+1)Non-Programmable	7 Day Programmable Non-Programmable		Remote Indoor Thermostat Sensor
		2H/2C	2H/2C	2H/3C Humidity Control	2H/3C Humidity Control WIFI	
						
Daikin Part Number		910411879	910411880	910417943	910417944	910420874
Feature						
LCD Display	Room Temperature & Setpoint	•	•	•	•	Allows Remote Temperature Sensing
	Room Humidity %			•	•	
Glow in the dark Display light		•	•	•	•	
Operating Modes	System	Heat-Off-Cool-Auto	Heat-Off-Cool-Auto	Heat-Off-Cool-Auto	Heat-Off-Cool-Auto	Use up to 16 sensors for temperature averaging
	Fan	On-Auto	On-Auto	On-Auto-IAQ	On-Auto-IAQ	
Changeover	Manual	•	•	•	•	
	Auto	•	•	•	•	
Temperature Control Range		44° F to 90° F (7° C to 32° C)	44° F to 90° F (7° C to 32° C)	44° F to 90° F (7° C to 32° C)	44° F to 90° F (7° C to 32° C)	
Adjustable Setpoint Limits		•	•	•	•	
Keypad Lockout				•	•	
Filter Change Reminder			•	•	•	
Programmable Fan		•	•	•	•	
Power Type	Battery	2 AA Alkaline Batteries				
	Hardwire (Common Wire)	18 to 30 VAC	18 to 30 VAC	18 to 30 VAC	18 to 30 VAC	
Permanent Memory Retention		•	•	•	•	
Remote Indoor Sensor Capable (Requires Daikin P/N: 910420874)			•	•	•	
Terminals		Rh, RC, G, Y, Y2, C, O, B, W/E, W2	Rh, RC, C, Y, Y2, W/E, W2, G, B, O, S1, S2	Rh, RC, C, Y, Y2, W/E, W2, G, B, O, S1, S2, H, D	Rh, RC, C, Y, Y2, W/E, W2, G, B, O, S1, S2, H, D	
Application						
Dehumidification	Smart Dehumidification			•	•	
	Simplified	•	•	•	•	
	Humidistat Controlled			•	•	
Electric Heat	Boilerless	•	•	•	•	
	Supplemental	•	•	•	•	
	Primary	•	•	•	•	
Waterside Economizer		•	•	•	•	
Hydronic Heat		•	•	•	•	

Table 15: Room Temperature Sensors

		Room Temperature Sensors			
		Basic Room Sensor	Cool to Warm Adjust	Digitally Adjustable Display Sensor	
Room Sensors for use with all WSHP units with a BACnet or LonWorks Communication Module: Console, V-Stack, Enfinity & SmartSource models					
		Temperature Sensing, LED Status Indication, Override/Reset Button	Cool/Warm Temperature Sensing Adjustment, LED Status Indication, Override/Reset Button	Temperature, Occupancy, Alarm, Setpoint and Status display, Override/Reset and Occupied/Unoccupied Buttons	Temperature, Humidity, Occupancy, Alarm, Setpoint and Status display, Override/Reset and Occupied/Unoccupied Buttons
Daikin Part Number		910152149	910171464	910152147	910121754
Feature					
Setpoint Adjustment		None	Cool to Warm	Digitally Adjustable	Digitally Adjustable
Display	Room Temperature & Setpoint			•	•
	Room Humidity & Setpoint				•
Stages	Heating	4	4	4	4
	Cooling	3	3	3	3
Operating Modes	System				Heat-Off-Cool-Auto Dehumidify
	Fan				On-Auto
	Occupancy			LCD Display of Occupied-Unoccupied Icon	LCD Display of Occupied-Unoccupied Icon
Annunciation	Status LED	•	•	LCD Display of Unit Status	LCD Display of Unit Status
	LCD Alarm Display			•	•
Reset	Alarm	•	•	•	•
	Setback Override	•	•	•	•
Application					
Dehumidification	Smart Dehumidification				•
Electric Heat	Boilerless	•	•	•	•
	Supplemental	•	•	•	•
	Primary	•	•	•	•
Waterside Economizer		•	•	•	•
Hydronic Heat		•	•	•	•

Piping

Units With Waterside Economizer

Figure 29: Unit with WSF Jumper Hose

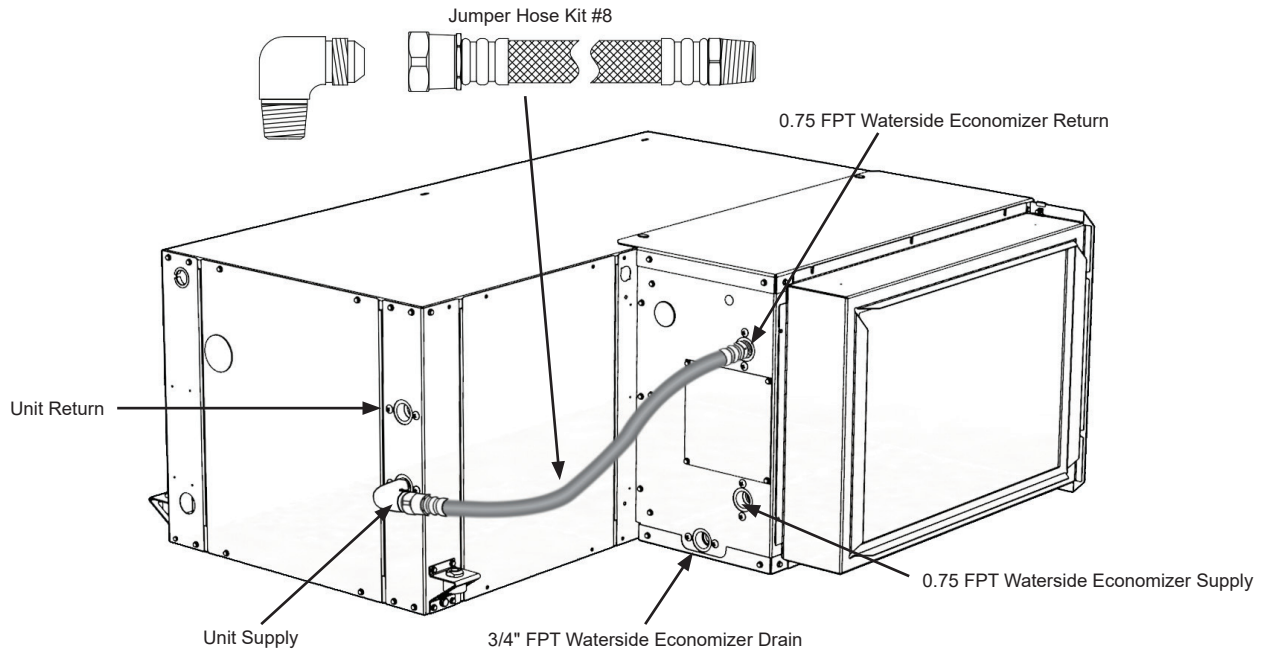

Right-Hand Unit With Waterside Economizer Jumper Hose

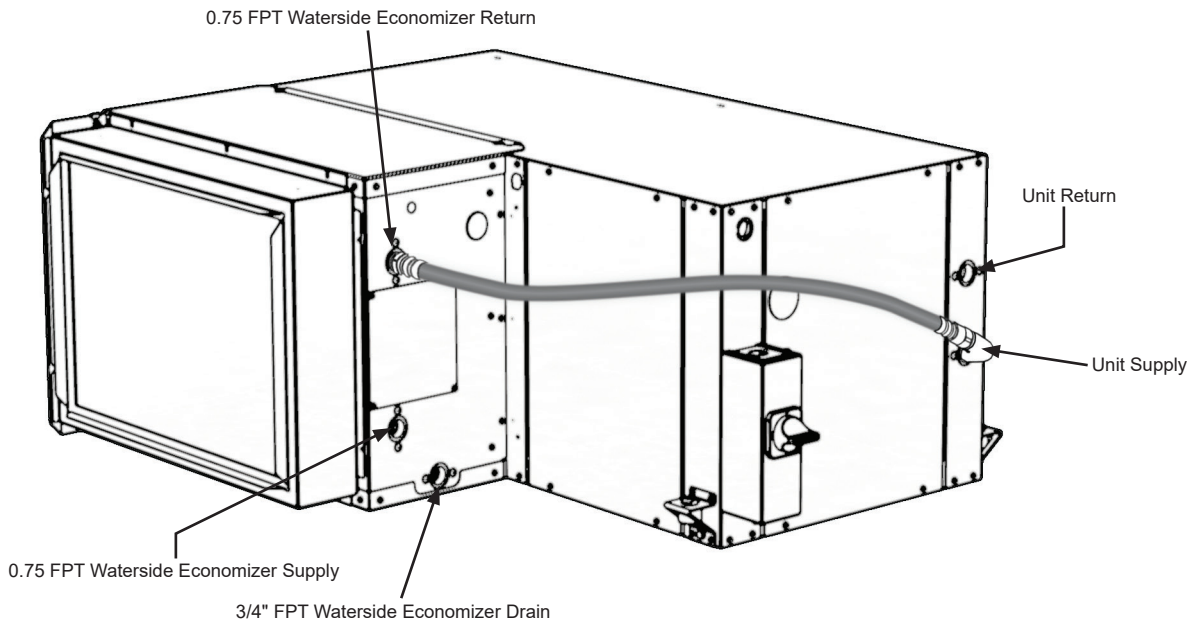

Left-Hand Unit With Waterside Economizer Jumper Hose

*Note: The economizer package incorporates its own drain pan to collect condensate from the coil. This pan **MUST** be independently trapped and can be piped into the drain line for the heat pump. See "Piping Considerations" on page 36.*

Waterside Economizer Piping Locations and Dimensions

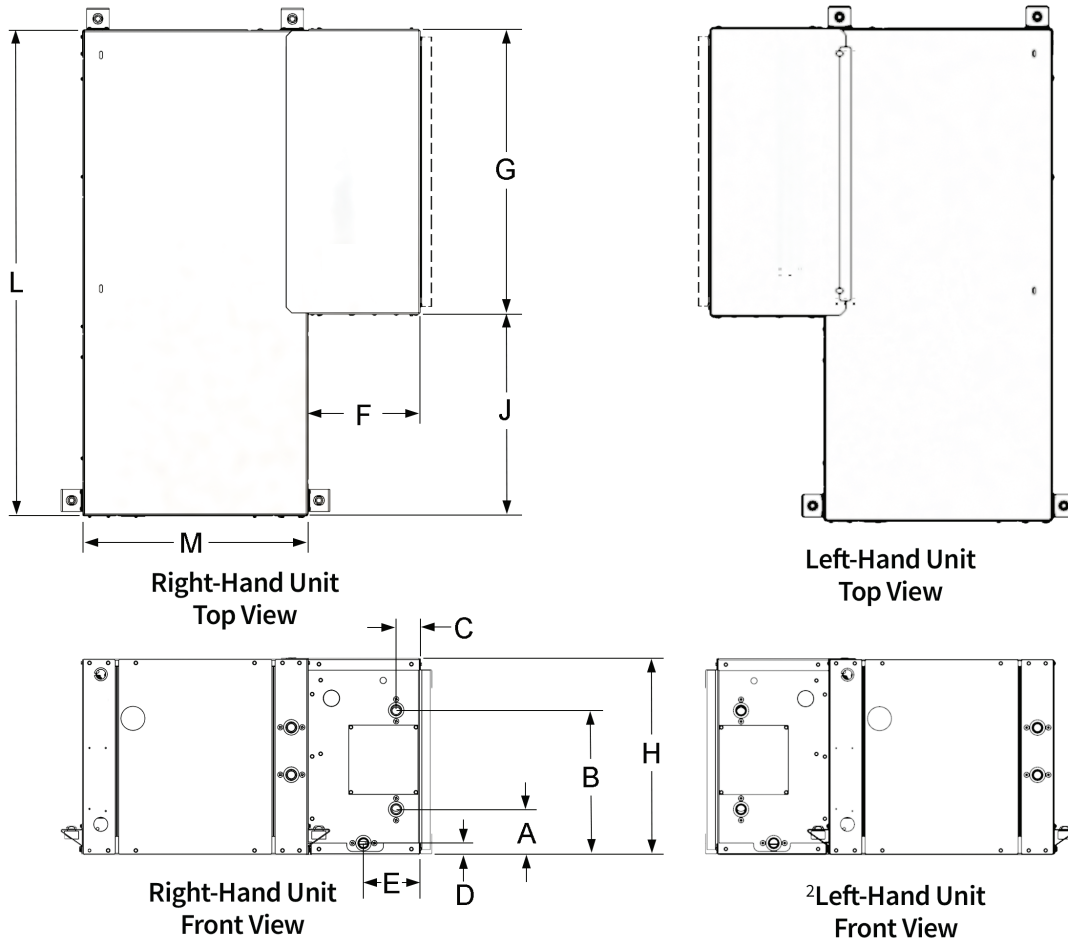
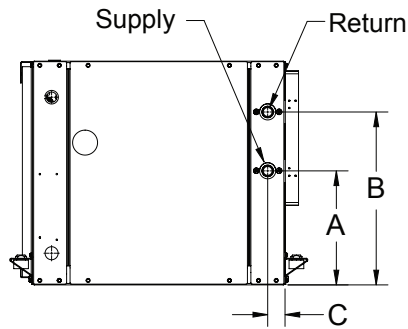

Table 16: Model GCH Unit with Waterside Economizer - Dimensions

Unit Size	WSE Supply & Return Connections				WSE 3/4" FPT Condensate Drain		Waterside Economizer Overall Cabinet Section			J	L	M
	Connection Size (FPT)	A (Supply)	B (Return)	C	D	E	F	G	H			
007, 009, 012	0.75	2.8	9.7	2.6	1.0	5.0	9.9	19.4	11.6	14.7	33.9	18.9
015, 019	0.75	4.0	12.5	2.1	1.0	5.0	9.9	25.6	17.1	16.4	42.0	18.9
024, 030	0.75	4.0	12.8	2.1	1.0	5.0	9.9	25.1	17.4	17.8	43.0	19.9
036, 042	0.75	3.5	13.5	2.1	1.0	5.0	9.9	30.6	19.1	18.4	49.0	21.4
048, 060	0.75	3.5	15.5	1.4	1.0	4.5	9.9	34.9	21.1	19.1	53.9	23.9
070	0.75	3.5	15.5	2.3	1.0	5.0	9.9	46.5	21.1	18.5	65.0	23.9

Notes: 1. All dimensions within ± 0.10 inches (2.5 mm).
 2. Left-hand waterside economizer connections same as right-hand but opposite.

Unit Supply and Return and Condensate Drain Connections



Front View - Water Connections

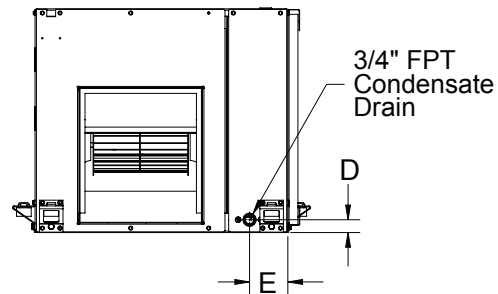

End View - Condensate Connection

Unit Size	Connection Size (FPT)	A	B	C		D	E
				Supply	Return		
007, 009	0.8	1.6	10.3	2.4	1.3	0.9	3.3
012	0.8	1.2	9.7	1.2	1.4	0.9	3.3
015, 019	0.8	7.9	11.4	1.5	1.5	1.4	3.3
024, 030	0.8	7.1	11.2	1.5	1.5	1.4	3.3
036, 042	0.8	9.7	14.6	1.5	1.5	1.4	3.3
048, 060	0.8	10.8	14.6	1.5	1.5	1.4	3.3
070	0.8	10.8	16.1	1.5	1.5	1.4	3.3

Piping Considerations

⚠ WARNING

Polyolester Oil, commonly known as POE oil is a synthetic oil used in many refrigeration systems, and may be present in this Daikin product. POE oil, if ever in contact with PVC/CPVC will coat the inside wall of PVC/CPVC pipe causing environmental stress fractures. Although there is no PVC/CPVC piping in this product, please keep this in mind when selecting piping materials for your application, as system failure and property damage could result.

Note: Do not over-torque fittings. The maximum torque without damage to fittings is 30 foot pounds. If a torque wrench is not available, use as a rule of thumb, finger tight plus one quarter turn.

1. No unit should be connected to the supply and return piping until the water system has been cleaned and flushed completely, see "Cleaning & Flushing System" on page 30. After the cleaning and flushing has taken place, the initial connection should have all valves wide open in preparation for water system flushing.
2. Supply and return shutoff valves are required at each unit. The return valve can be used for balancing. When used it should have a "memory stop" so that it can be closed off, and reopened to the proper position for the required flow.

Note: Improper trapping can lead to several problems. If the trap is too tall, negative pressure will prevent drainage, causing condensate backup. If the trap is too short the seal will be destroyed or nonexistent, producing the same effect as a non-trapped system.

3. Each water source heat pump is provided with a 3/4" FPT flush mount fitting for connection of a condensate drain. Copper or steel condensate piping should be insulated to prevent sweating. Do not locate any point in the drain system above the condensate drain connection of any unit.

Note: It may be necessary to manually fill the trap at system startup, or to run the unit for sufficient time to build a condensate seal. The condensate trap and condensate piping drainage should be free of any foreign debris. Debris can prevent proper drainage and unit operation and result in condensate buildup.

Condensate Drain - General

A field provided condensate trap must be installed on each water source heat pump. Condensate removal piping must be pitched away from the unit not less than 1/4" per foot. An air vent is sometimes required after the trap to prevent air pockets, so the condensate will drain away from the unit. The vent can also act as a clean out if the trap becomes clogged. To avoid having waste gases entering the building, the condensate drain should not be directly piped to a drain/waste/vent stack, etc. Always connect the drain through a trap to the condensate drain system in accordance to the local plumbing codes.

Figure 30: Unit Condensate Drain Pipe Trap Detail

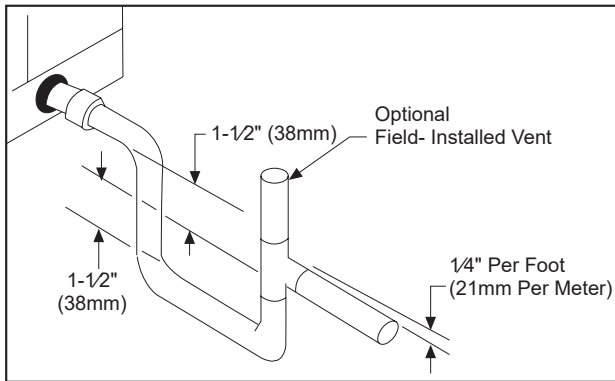

Cleaning & Flushing System

1. Prior to first operation of any conditioner, the water circulating system must be cleaned and flushed of all construction dirt and debris. If the conditioners are equipped with water shutoff valves, either electric or pressure operated, the supply and return runouts must be connected together at each conditioner location. This will prevent the introduction of dirt into the unit. See Figure 31.

Figure 31: Supply and Return Runouts Connected Together

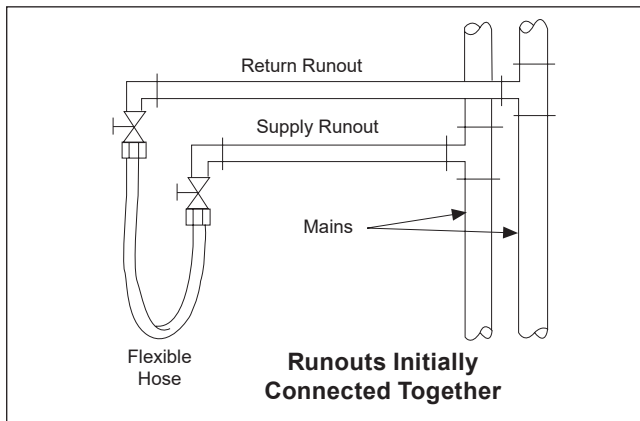

2. Fill the system at the city water makeup connection with all air vents open. After filling, close all air vents. The contractor should start main circulator with the pressure reducing valve open. Check vents in sequence to bleed off any trapped air, ensuring circulation through all components of the system. Power to the heat rejector unit should be off, and the supplementary heat control set at 80°F (27°C). While circulating water, the contractor should check and repair any leaks in the piping. Drains at the lowest point(s) in the system should be opened for initial flush and blowdown, making sure city water fill valves are set to make up water at the same rate. Check the pressure gauge at pump suction and manually adjust the makeup to hold the same positive steady pressure both before and after opening the drain valves. Flush should continue for at least two hours, or longer if required, to see clear, clean drain water.
3. Shut off supplemental heater and circulator pump and open all drains and vents to completely drain down the system. Short circuited supply and return runouts should now be connected to the conditioner supply and return connections. Do not use sealers at the swivel flare connections of hoses.
4. Trisodium phosphate was formerly recommended as a cleaning agent during flushing. However, many states and localities ban the introduction of phosphates into their sewage systems. The current recommendation is to simply flush longer with warm 80°F (27°C) water.
5. Refill the system with clean water. Test the water using litmus paper for acidity, and treat as required to leave the water slightly alkaline (pH 7.5 to 8.5). The specified percentage of antifreeze may also be added at this time. Use commercial grade antifreeze designed for HVAC systems only. Do not use automotive grade antifreeze. Once the system has been filled with clean water and antifreeze (if used), precautions should be taken to protect the system from dirty water conditions. Dirty water will result in system wide degradation of performance and solids may clog valves, strainers, flow regulators, etc. Additionally, the heat exchanger may become clogged which reduces compressor service life or causes premature failure.
6. Set the loop water controller heat add setpoint to 70°F (21°C) and the heat rejection setpoint to 85°F (29°C). Supply power to all motors and start the circulating pumps. After full flow has been established through all components including the heat rejector (regardless of season) and air vented and loop temperatures stabilized, each of the conditioners will be ready for check, test and start-up, air balancing, and water balancing.

Controls

Table 17: MicroTech III SmartSource Unit Controller Terminals and Descriptions

H1 - 1	24	24 VAC Power Input
H1 - 2	C	24 VAC common
H2 - 1	SL1	Fan Main Required Output – Switched L1
H2 - 2		Blank Terminal
H2 - 3	N	Fan Main Required Output – Neutral
H3 - 1	HP1-1	Comp High Pressure Switch (HP1) Input Terminal 1
H3 - 2	HP1-2	Comp High Pressure Switch (HP1) Input Terminal 2
H4 - 1	1	Discharge Air Temp Sensor – Common
H4 - 2		Discharge Air Temp Sensor – Signal
H4 - 3		Leaving Water Temp Sensor – Common
H4 - 4		Leaving Water Temp Sensor – Signal
H5 - 1	1	Connections to I/O Expansion Board
H5 - 2		
H5 - 3		
H5 - 4		
H5 - 5		
H5 - 6		
H5 - 7		
H5 - 8		
H5 - 9		
H5 - 10		
H5 - 11		
H5 - 12		
H6 - 1	1	Condensate Overflow Signal Input
H6 - 2		Compressor Suction Temp Sensor (LT1) – Common
H6 - 3		Compressor Suction Temp Sensor (LT1) – Signal
H6 - 4		Compressor Low Pressure Switch (LP1) – Source Voltage
H6 - 5		Compressor Low Pressure Switch (LP1) – Signal
H6 - 6		Reversing Valve – Common
H6 - 7		Reversing Valve – Output
H7 - 1	1	No Connection
H7 - 2		No Connection
H7 - 3		Red LED Output
H7 - 4		Green LED Output
H7 - 5		Yellow LED Output
H7 - 6		Red-Green-Yellow LED Common
H8 - 1	1	Isolation Valve/Pump Request Relay N/O
H8 - 2		Isolation Valve/Pump Request Relay N/C
H8 - 3		24 VAC Common
H9 - 1	1	Return Air Sensor – Signal
H9 - 2		Return Air Sensor – Common
TB1 - 1	1	Room Sensor – Status LED Output
TB1 - 2	2	Room Sensor – Fan Mode & Unit Mode Switches
TB1 - 3	3	Room Sensor – Setpoint Adjust Potentiometer
TB1 - 4	4	Room Sensor – Room Temp Sensor & Tenant Override
TB1 - 5	5	Room Sensor – DC Signal Common
TB2 - 1	R	24 VAC
TB2 - 2	A	Thermostat – Alarm Output
TB2 - 3	W2	Thermostat – Heat Stage #2 (W2) Input
TB2 - 4	W1	Thermostat – Heat Stage #1 (W1) Input
TB2 - 5	Y2	Thermostat – Cool Stage #2 (Y2) Input
TB2 - 6	Y1	Thermostat – Cool Stage #1 (Y1) Input

TB2 - 7	G	Thermostat – Fan Input
TB2 - 8	O	Thermostat – Heat Stage #3 (W3) Input
TB2 - 9	C	24 VAC Common
TB3 - 1	E	Emergency Shutdown Input
TB3 - 2	U	Unoccupied Input
L1 - 1	L1 - 1	Line Voltage Terminal 1
L1 - 2	L1 - 2	Line Voltage Terminal 2
L1 - 3	L1 - 3	Line Voltage Terminal 3
N1	N1	Neutral Terminal 1
N2	N2	Neutral Terminal 2
N3	N3	Neutral Terminal 3

Table 18: I/O Expansion Module Connectors / Terminals

H1 - 1	1	Connections to Main Board
H1 - 2		
H1 - 3		
H1 - 4		
H1 - 5		
H1 - 6		
H1 - 7		
H1 - 8		
H1 - 9		
H1 - 10		
H1 - 11		
H1 - 12		
H2 - 1	1	Auxiliary Heat Stage #2 Output – N/O
H2 - 2		No Connection
H2 - 3		24 VAC Common
H3 - 1	1	Ext. 24 VAC In
H3 - 2		Ext. 24 VAC Common In
H3 - 3		HGR / Waterside Economizer Output – N/O
H3 - 4		Ext. 24 VAC Common
H3 - 5		ECM Fan Motor Variable Speed Signal Output
H3 - 6		ECM Fan Motor Variable Speed Signal – Common
H4 - 1	1	Entering Water Temp Sensor – Signal
H4 - 2		Entering Water Temp Sensor – Common
H5 - 1	1	No Connection
H5 - 2		No Connection
H5 - 3		Red LED Output
H5 - 4		Green LED Output
H5 - 5		Yellow LED Output
H5 - 6		Red-Green-Yellow LED Common
H6 - 1	HP2-1	Jumper Wire Connection (for single stage)
H6 - 2	HP2-2	Jumper Wire Connection (for single stage)
H7 - 1		Fan Speed Selector – Signal
H7 - 2		Fan Speed Selector – Common
H7 - 3		Thermostat – Heat Stage #4 (W4) Input – Signal
H7 - 4		Auxiliary 24 VAC Out
H8 - 1	1	Compressor – High Capacity Output – N/O
H8 - 2		24 VAC Common
H8 - 3		No Connection
H8 - 4		Auxiliary Heat Stage #1 / Hydronic Heat Output N/O (24 VAC)
H8 - 5		24 VAC Common
TB1 - 1	1	Humidistat Signal Input
TB1 - 2	2	Thermostat - Heat Stage #4 (W4) Input – Signal

Figure 32: MicroTech SmartSource Unit Controller and I/O Expansion Module

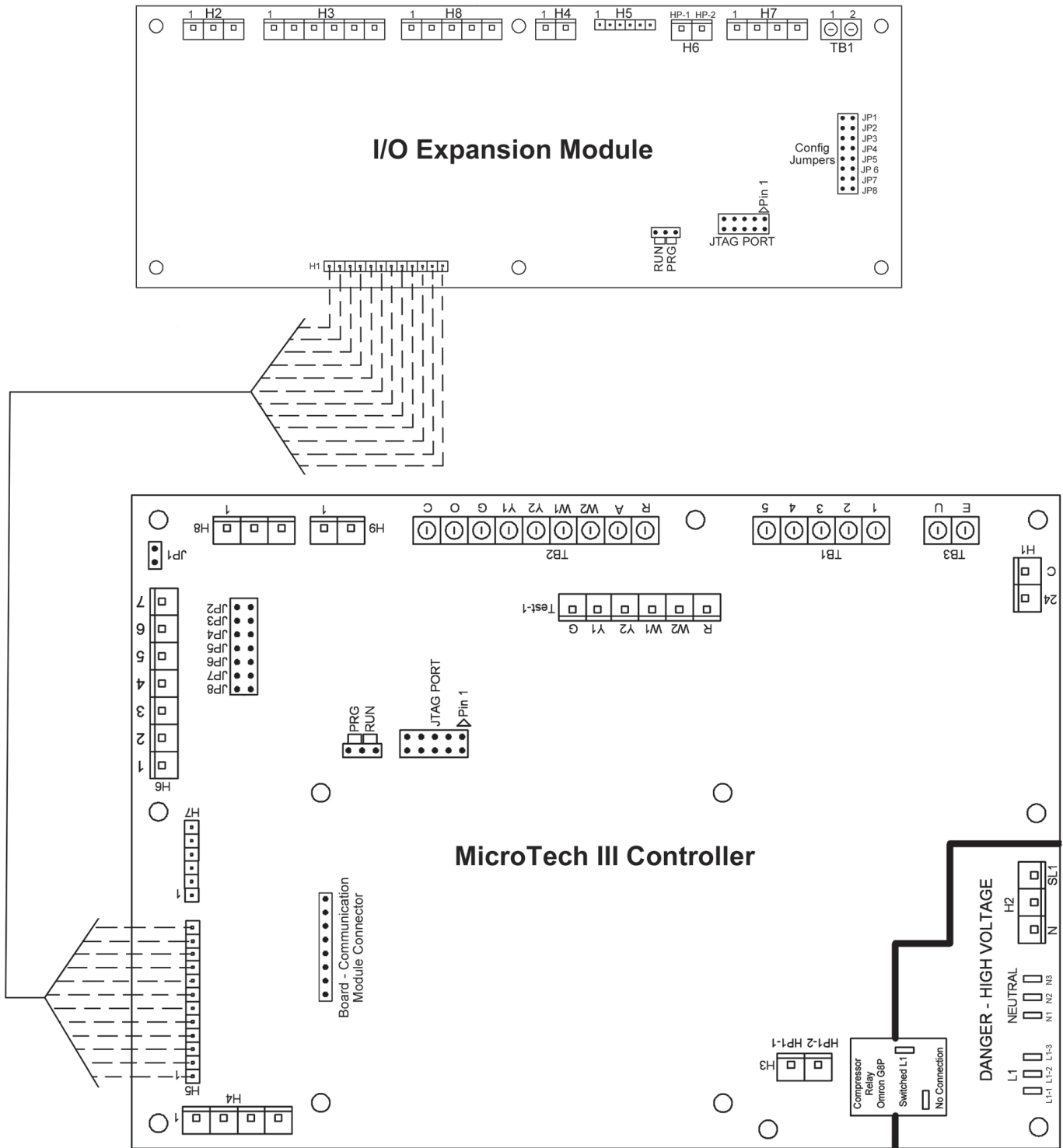

Note: Refer to [Table 15 on page 33](#) for terminal descriptions

Jumper Configuration Settings

Figure 33: Configuration Jumpers Location

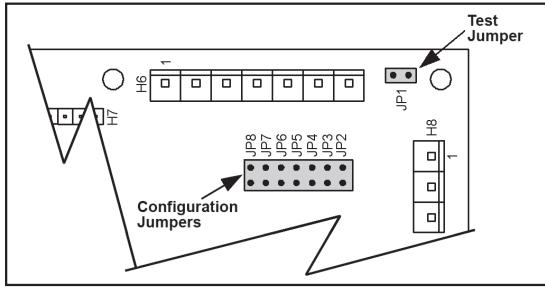

⚠ WARNING

Proper antifreeze/water solution is required to minimize the potential of fluid freeze-up. Jumper JP3 is factory set for water freeze protection with the jumper open. Operation at fluid temperatures below 32°F with anti-freeze protection requires JP3 to be field configured for the jumper closed. If unit is employing a fresh water system (no anti-freeze protection), it is extremely important that JP3 jumper setting remains in the open position (factory default setting) in order to shut down the unit at the appropriate water temperature to protect your heat pump from freezing. Failure to do so can result in unit damage, property damage and could void unit warranty.

Table 19: MicroTech III Main Board Jumper Settings and Descriptions

Jumper	Description	Options
JP1	Mode	Open for normal operation mode
		Shorted for service/test operation mode
JP2	Fan operation	Open for continuous fan operation, when not in unoccupied mode.
		Shorted for cycling fan operation
JP3 (See Warning)	Freeze Protection	Open for water freeze protection
		Shorted for systems with anti-freeze protection (15°F (9°C))
JP4	Freeze Fault Protection	Open for none
		Shorted to enable freeze fault protection based on Leaving Water Temperature (LWT)
JP5	Set point adjustment range only applies to network controls with a room temperature sensor	Open for adjustment range of -5.0° to +5.0° F
		Shorted for 55° to 95° F adjustment range
JP6	Room control type	Open for thermostatic room control
		Shorted for room temperature sensor control, MicroTech III only.
JP7	Compressor heating source	Open to enable compressor heating
		Shorted to disable compressor heating
JP8	I/O expansion module	Open when I/O expansion module is not needed
		Shorted when I/O expansion module is required

Table 20: I/O Expansion Module Jumper Settings

I/O Expansion Description	Jumper(s)	Setting	Model
Fan Row Select for Operating Modes: • Fan Only • Waterside Economizer	JP1 & JP2	JP1 = Open JP2 = Open	Fan Row "A" Selected
		JP1 = Shorted JP2 = Open	Fan Row "B" Selected
		JP1 = Open JP2 = Shorted	Fan Row "C" Selected
		JP1 = Shorted JP2 = Shorted	Fan Row "D" Selected
Secondary Heating Options	JP3 & JP4	JP3 = Open JP4 = Open	None
		JP3 = Shorted JP4 = Open	Supplemental Electric Heat
		JP3 = Open JP4 = Shorted	Boilerless Electric Heat
		JP3 = Shorted JP4 = Shorted	Hydronic Heat
Dehumidification Options / Waterside Economizer	JP5 & JP6	JP5 = Open JP6 = Open	None
		JP5 = Shorted JP6 = Open	Hot Gas/Water Reheat (HGR)
		JP5 = Open JP6 = Shorted	Waterside Economizer
Not Used	JP7	JP7 = Open	—
Compressor Capacity Option	JP8	JP8 = Open JP8 = Shorted	Single-Stage Capacity Dual-Stage Capacity

MicroTech® III SmartSource Unit Controller

The MicroTech III SmartSource unit controller allows thermostat, Daikin sensor and DDC standalone operation. The R (24VAC) terminal is used to operate thermostat inputs G, Y1, Y2, W1, W2, W3, W4 and TB1-1. The C (common) terminal is used to control inputs U, E and O. No external power sources may be used to operate the MicroTech III controller. All units must be properly grounded per local code requirements.

NOTICE
For information on sequence of operation and troubleshooting refer to OM 1149-xx.

Remote Reset of Automatic Lockouts

The Remote Reset feature provides the means to remotely reset automatic lockouts. There are (3) means to reset an automatic lockout condition:

- Using the thermostat create 2 demands for capacity within 30 seconds
- Press the Room Sensor or Thermostat Timed Override/Reset Button for more than 10 seconds
- Turn the unit power off

When the cause of the fault condition has been cleared, and the unit transitions from not requiring any capacity to needing any capacity twice within 30 seconds (accomplished by user manipulation of the Heat/Cool/Auto/Off switch on the thermostat), an alarm reset equivalent to a tenant override button reset is generated. The intelligent reset counter and the 24 hour timer are cleared when this type of alarm reset is generated.

Note: *This feature only applies to thermostat controlled systems.*

For room sensor controlled units, pressing the "Override" or "Reset" button for more than 10 seconds will apply a ground signal to the tenant override in (screw terminal connection at TB1 pin 4) will clear the lockout alarm once the cause of the fault condition has been cleared.

A unit power cycle can also be used to clear an automatic lockout if the conditions causing the fault have been cleared.

Table 21: MicroTech III SmartSource Unit Controller Fault and Status LED's

Description	Type	Yellow	Green	Red
I/O Expansion Communication Fail	Fault	ON	Flash	Flash
Invalid Configuration	Fault	Flash	Flash	OFF
Low Voltage Brownout	Fault	OFF	Flash	OFF
Emergency Shutdown	Mode	OFF	Flash	OFF
Compressor High Pressure	Fault	OFF	OFF	Flash
Compressor Low Pressure	Fault	OFF	OFF	ON
Compressor Suction Temp Sensor Fail	Fault	Flash	Flash	ON
Compressor Low Suction Temp	Fault	Flash	OFF	OFF
Freeze Fault Detect	Fault	Flash	OFF	Flash
Room Temp Sensor Fail (Room Sensor Control Only)	Fault	Flash	Flash	ON
Leaving Water Temp Sensor Fail	Fault	Flash	Flash	ON
Condensate Overflow	Fault	ON	OFF	OFF
Serial EEPROM Corrupted	Fault	ON	ON	ON
Waterside Economizer Low Temp Cutout (WSE Control & Call for Cooling)	Mode	Flash	ON	Flash
Service Test Mode Enabled	Mode	Flash	Flash	Flash
Unoccupied Mode	Mode	ON	ON	OFF
Occupied, Bypass, Standby, or Tenant Override Modes	Mode	OFF	ON	OFF

Note: Mode/faults are listed in order of priority.

Table 22: I/O Expansion Module Fault and Status LED's

Description	Type	Yellow	Green	Red
Baseboard Communication Fail	Fault	Flash	OFF	Flash
Entering Water Temp Sensor Fail (Boilerless Electric Heat or Waterside Economizer Only or Hydronic Heat)	Fault	ON	OFF	Flash
Low Entering Water Temperature (No Display On Boilerless Electric Heat)	Fault	OFF	ON	Flash
Fan is OFF	Mode	OFF	ON	OFF
Fan Running at Low Speed (0 to 33%) Duty Cycle	Mode	OFF	Flash	OFF
Fan Running at Medium Speed (34 to 66%) Duty Cycle	Mode	ON	Flash	OFF
Fan Running at High Speed (67 to 100%) Duty Cycle	Mode	Flash	Flash	OFF

Table 23: Fault Recovery and Reset

Fault Description	Auto Recovery	Tenant Override Button Reset	Network Reset
I/O Expansion Communication Fail	Yes	No	No
Invalid Configuration	No	No	No
Low Voltage Brownout	Yes	No	Yes
All Sensor Failures	No	No	Yes
Compressor High Pressure	No	Yes	Yes
Compressor Low Pressure	No	Yes	Yes
Compressor Low Suction Temp or Freeze Fault Detect (Heating and Cooling Modes)	Yes ¹	Yes	Yes
Compressor Low Suction Temp or Freeze Fault Detect (Dehumidification Mode)	Yes	Yes	Yes
Condensate Overflow	Yes	No	Yes
Low Entering Water Temp	Yes	No	No
Serial EEPROM Corrupted	No	No	No
Waterside Economizer Low Temp Cutout	Yes	No	No

Note: ¹ Indicates auto recover is subject to intelligent alarm reset. Alarm auto recovers on first two occurrences, locked out on third within 24 hour period.

See "Remote Reset of Automatic Lockouts" on page 41 for further details.

MicroTech SmartSource Controller with LONWORKS® Communication Module

For installation and operation information on LONWORKS Communication Module and other ancillary control components, see:

- IM 927 - MicroTech III Water Source Heat Pump LONWORKS Communication Module
- IM 933 - LonMaker Integration Plug-in Tool: For use with the MicroTech III SmartSource Unit Controller
- IM 955 - MicroTech III Wall Sensor for use with MicroTech III SmartSource Unit Controller
- IM 956 - Temperature Sensors for Units with MicroTech® III Unit Controller and LONWORKS® or BACnet® Communication Module

Figure 34: LONWORKS Communication Module

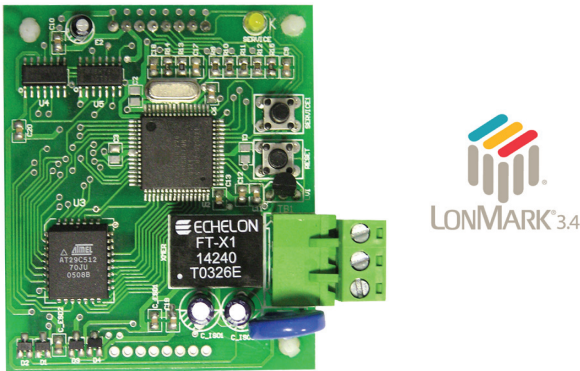

MicroTech SmartSource Controller with BACnet® Communication Module

For installation and operation information on MicroTech III SmartSource unit controller and other ancillary components, see:

- IM 928 - MicroTech III BACnet Communication Module
- OM 931 - MicroTech III SmartSource Unit Controller for Water Source Heat Pumps Operation and Maintenance Manual
- IM 955 - MicroTech III Wall Sensor For use with MicroTech III SmartSource Unit Controller
- IM 956 - Temperature Sensors for Units with MicroTech® III Unit Controller and LONWORKS® or BACnet® Communication Module

Figure 35: MicroTech III BACnet Water Source Heat Pump Snap-In Communication Module

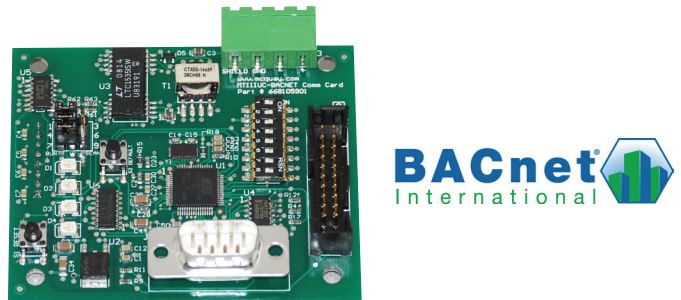

Fan Performance for Standard PSC Motor - 208V Operation

Table 24: PSC Motor CFM Values

Unit Size	Setting	Rated Airflow	External Static Pressure (in-H ₂ O) [Dry Coil and Standard Filter] (inches of water column)														
			.05	.10	.20	.30	.40	.45	.50	.60	.70	.80	.90	1.0	1.1	1.2	
007	High	250	430	422	407	389	364	349	331	288	233						
	Medium		347	340	327	312	291	278	262	224	177						
	Low		302	295	282	266	245	233	218	183							
009	High	300	430	422	407	389	364	349	331	288	233						
	Medium		347	340	327	312	291	278	262	224							
	Low		302	295	282	266	245	233	218								
012	High	400	430	422	407	389	364	349	331	288							
	Medium		347	340	327	312	291										
	Low		302	295	282												
015	High	500	906	886	862	830	769	723	667	525	352						
	Medium		730	715	695	666	611	571	522	401							
	Low		655	642	621	587	524	481	431								
019	High	600	924	912	873	832	791	768	739	647	469						
	Medium		734	719	700	674	626	591	548	439							
	Low		659	648	627	591	529	489	443								
024	High	800	967	958	945	925	885	855	817	718	591						
	Medium		829	826	824	814	783	757	723	633							
	Low		703	704	708	703	680	659	632								
030	High	1000	1307	1280	1210	1136	1066	1031	995	906	769						
	Medium		1274	1249	1181	1107	1039	1006	972	885	745						
	Low		1220	1198	1136	1069	1005	973	939	853	713						
036	High	1200	1450	1404	1353	1321	1278	1243	1198	1068	880						
	Medium		1517	1455	1399	1382	1352	1321	1274	1130	914						
	Low		1335	1303	1269	1246	1207	1176	1134	1014	841						
036 (265V)	High	1200	1450	1404	1353	1321	1278	1243	1198	1068	880						
	Medium		1517	1455	1399	1382	1352	1321	1274	1130	914						
	Low		1335	1303	1269	1246	1207	1176	1134	1014	841						
042 (208V)	High	1400	1641	1615	1587	1570	1545	1523	1494	1407	1277	1101					
	Medium		1442	1430	1425	1423	1405	1385	1357	1268	1138						
	Low		1245	1244	1245	1246	1235	1223	1205	1144	1042						
042 (460V)	High	1400	1754	1732	1693	1654	1607	1577	1541	1446	1312	1125					
	Medium		1615	1594	1573	1557	1528	1503	1470	1372	1230	1042					
	Low		1456	1441	1432	1429	1407	1386	1354	1260	1125						
048	High	1600	1789	1780	1751	1713	1668	1644	1618	1559	1483	1379	1230				
	Medium		1492	1499	1490	1467	1440	1426	1412	1378	1325	1234					
	Low		1256	1265	1268	1261	1252	1246	1238	1214	1162						
060	High	2000	2356	2323	2261	2199	2126	2084	2038	1930	1804	1661	1507				
	Medium		2132	2109	2066	2020	1963	1928	1889	1795	1682	1553	1415				
	Low		1861	1848	1823	1793	1750	1722	1690	1612	1516	1406					
070	High	2300	2539	2533	2518	2498	2470	2452	2430	2377	2309	2223	2121	2001	1864	1710	
	Medium		2177	2175	2169	2161	2146	2137	2124	2093	2049	1991	1918	1827	1716		
	Low		1873	1872	1868	1861	1849	1841	1832	1809	1777	1734					

- Notes:**
1. Speed adjustment is done at terminal strip on the motor. Refer to unit schematic.
 2. Gray tinted areas, outside recommended operating range.
 3. Refer to schematic supplied with the unit for wiring as supplied by the factory. Wire colors BK = hi, BL = med & RD = low.

Fan Speed Selector Switch

A 4-position fan speed selector switch located in the control box allows CFM settings to be field adjustable. Fan speed control optimizes unit fan speed based on thermostat/room sensor inputs. The fan speed switch allows for manually setting an optimal fan speed specific to the application requirements. Each position on the fan speed switch represents settings 1-4. See [Table 25](#) below, [Table 26 on page 47](#) and [Table 27 on page 48](#) for the complete list of fan speed selector switch settings.

Figure 36: 4-Position Fan Speed Selector Switch

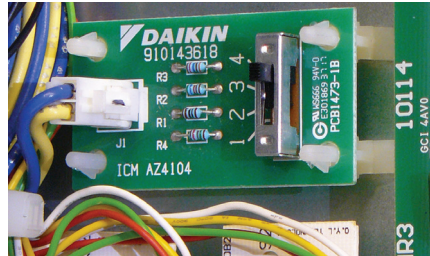

Fan Performance For Optional Constant Torque EC Motor (Sizes 007–012)

Table 25: Constant Torque EC Motor CFM Values

Unit Size	Setting	Function	External Static Pressure (in-H ₂ O) [Dry Coil and Standard Filter] (inches of water column)												
			0.1	0.15	0.2	0.25	0.3	0.35	0.4	0.45	0.5	0.55	0.6	0.65	0.7
007	Setting 4	Stage 1	324	311	297	281	266	250	236	221	208	194	180	165	
	Setting 3		300	286	270	252	235	218	202	186	172				
	Setting 2		274	259	242	223	204	185	167						
	Setting 1		274	259	242	223	204	185	167						
	Setting 4	Stage 2	345	335	324	312	299	285	270	255	239	223	206	190	174
	Setting 3		324	311	297	281	266	250	236	221	208	194	180	165	
	Setting 2		300	286	270	252	235	218	202	186	172				
	Setting 1		274	259	242	223	204	185	167						
	A	Fan Only, and WSE	274	259	242	223	204	185	167						
	B		274	259	242	223	204	185	167						
C	231		213	192	171										
D*	231		213	192	171										
009	Setting 4	Stage 1	357	348	337	326	314	301	287	272	257	240	224		
	Setting 3		330	318	304	290	275	260	245	231	216				
	Setting 2		296	282	266	248	231	213							
	Setting 1		296	282	266	248	231	213							
	Setting 4	Stage 2	385	375	365	354	342	330	319	306	294	281	267	252	236
	Setting 3		357	348	337	326	314	301	287	272	257	240	224		
	Setting 2		330	318	304	290	275	260	245	231	216				
	Setting 1		296	282	266	248	231	213							
	A	Fan Only, and WSE	296	282	266	248	231	213							
	B		296	282	266	248	231	213							
C	246		228												
D*	246		228												
012	Setting 4	Stage 1	409	399	388	376	365	354	344	333	323	312	300	287	
	Setting 3		376	366	356	345	333	321	308	295	281				
	Setting 2		345	335	324	312	299	285							
	Setting 1		345	335	324	312	299	285							
	Setting 4	Stage 2	449	438	426	414	403	392	381	372	362	353	343	331	317
	Setting 3		409	399	388	376	365	354	344	333	323	312	300	287	
	Setting 2		376	366	356	345	333	321	308	295	281				
	Setting 1		345	335	324	312	299	285							
	A	Fan Only, and WSE	345	335	324	312	299	285	270	255	239	223	206	190	
	B		345	335	324	312	299	285	270	255	239	223	206	190	
C	296		282	266	248	231	213	197	181						
D*	296		282	266	248	231	213	197	181						

- Notes:**
1. Gray tinted areas, outside recommended operating range.
 2. Units are shipped at setting 3 (standard). Speed adjustment is done by 4-position switch in the control box.
 3. The unit is capable of high-low fan performance through the use of a 2-stage thermostat wired to specific terminals for High-Low CFM fan performance. Standard operation with a 1-stage thermostat is indicated as stage 2 fan performance

* Exception - WSE operates at row "C" airflows.

Note: See [Table 28 on page 49](#) for jumper configuration location.

Fan Performance For Optional Constant Torque EC Motor (Sizes 015–070)

Table 26: Constant Torque EC Motor CFM Values

Unit Size	Setting	Rated Airflow	External Static Pressure (in-H ₂ O) [Dry Coil and STD Filter] (inches of water column)											
			.05	.10	.20	.30	.40	.45	.50	.60	.70	.80	.90	1.0
015	Setting 5 (High)	500	810	784	761	754	741	728	708	644	547	420		
	Setting 4 (High)		765	745	709	675	639	620	598	549	489	415		
	Setting 3 (Standard)		694	679	639	592	543	518	494	446	397			
	Setting 2 (Medium)		632	602	549	500	452	427	402					
	Setting 1 (Low)		576	537	463	397								
019	Setting 5 (High)	600	881	851	833	838	835	824	803	730	613	460		
	Setting 4 (High)		822	796	768	752	734	720	700	644	562	454		
	Setting 3 (Standard)		751	729	697	670	639	620	598	541	467			
	Setting 2 (Medium)		685	668	628	584	539	516	494	447				
	Setting 1 (Low)		631	609	554	495	436							
024 208/230V & 277V	Setting 5 (High)	800	1197	1183	1140	1086	1029	999	968	896	798	654		
	Setting 4 (High)		1068	1056	1034	1010	980	962	939	875	779	637		
	Setting 3 (Standard)		932	918	883	852	830	821	812	787	730	610		
	Setting 2 (Medium)		893	882	843	804	778	771	765	747	688			
	Setting 1 (Low)		830	814	775	738	710	699	689	663	611			
024 460V	Setting 5 (High)	800	1272	1243	1181	1113	1042	1005	965	877	770	633		
	Setting 4 (High)		1063	1052	1032	1011	978	955	927	851	744	604		
	Setting 3 (Standard)		925	912	883	855	831	819	806	772	710	601		
	Setting 2 (Medium)		874	861	833	804	776	762	748	718	683	636		
	Setting 1 (Low)		819	805	776	745	714	699	683	652	619	582		
030	Setting 5 (High)	1000	1222	1198	1142	1071	980	926	866	731				
	Setting 4 (High)		1198	1170	1123	1069	990	939	879	735				
	Setting 3 (Standard)		1187	1168	1125	1063	975	920	858	715				
	Setting 2 (Medium)		1085	1076	1058	1022	954	906	847	705				
	Setting 1 (Low)		1020	1013	1002	974	916	874	822					
036	Setting 5 (High)	1200	1480	1461	1404	1341	1282	1254	1223	1143	1009			
	Setting 4 (High)		1445	1434	1387	1328	1269	1240	1208	1128	997			
	Setting 3 (Standard)		1404	1393	1353	1305	1256	1231	1202	1123	991			
	Setting 2 (Medium)		1269	1256	1227	1201	1180	1168	1152	1098	984			
	Setting 1 (Low)		1222	1208	1171	1139	1118	1110	1101	1064	970			
042	Setting 5 (High)	1400	1868	1843	1777	1699	1613	1568	1522	1426	1321	1198	1048	
	Setting 4 (High)		1785	1774	1727	1658	1578	1536	1492	1401	1302	1185	1038	
	Setting 3 (Standard)		1532	1514	1491	1471	1446	1428	1406	1342	1251	1128		
	Setting 2 (Medium)		1482	1465	1437	1414	1390	1375	1358	1310	1239	1117		
	Setting 1 (Low)		1434	1420	1389	1358	1328	1314	1298	1262	1211	1091		
048	Setting 5 (High)	1600	1852	1841	1809	1775	1747	1735	1725	1704	1670	1601	1468	1236
	Setting 4 (High)		1811	1800	1764	1725	1692	1680	1669	1650	1621	1561	1438	1215
	Setting 3 (Standard)		1739	1731	1695	1651	1614	1601	1590	1574	1553	1507	1404	1206
	Setting 2 (Medium)		1683	1676	1637	1588	1548	1533	1523	1512	1501	1468	1377	1184
	Setting 1 (Low)		1635	1624	1581	1531	1489	1474	1464	1452	1441	1412	1334	1168
060	Setting 5 (High)	2000	2316	2298	2257	2208	2149	2114	2076	1988	1882	1756	1607	1432
	Setting 4 (High)		2246	2229	2195	2155	2105	2075	2040	1958	1856	1732	1586	1418
	Setting 3 (Standard)		2163	2145	2114	2083	2045	2021	1994	1926	1838	1725	1586	1421
	Setting 2 (Medium)		2101	2078	2040	2007	1974	1956	1935	1884	1815	1720	1594	1430
	Setting 1 (Low)		2019	2003	1966	1925	1885	1865	1845	1802	1751	1680	1579	1429
070	Setting 5 (High)	2300	2489	2467	2426	2387	2351	2333	2315	2276	2228	2164	2075	1950
	Setting 4 (High)		2474	2453	2413	2377	2342	2324	2305	2264	2212	2144	2053	1929
	Setting 3 (Standard)		2464	2444	2406	2370	2336	2319	2302	2263	2216	2152	2063	1939
	Setting 2 (Medium)		2408	2388	2345	2304	2265	2247	2229	2193	2151	2098	2023	1913
	Setting 1 (Low)		2310	2293	2256	2218	2181	2163	2145	2108	2066	2014	1944	1847

Notes: 1. Gray tinted areas, outside recommended operating range.

2. Units are shipped at setting 3 (standard), setting 5 (high) for unit size 070. Speed adjustment is done at motor terminal strip

3. Motor speed adjustments can be made by moving wire to appropriate motor tap 1-5.

Fan Performance For Optional Constant CFM EC Motor (Sizes 015–070)

Table 27: Single or Two-Stage Units With Constant CFM EC Motor

Unit Size	MicroTech Unit Controller						I/O Expansion Module		
	Setting	Maximum ESP (in. wg.) ²	Heat/Cool Stage 1 + Hydronic Coil	Heat/Cool Stage 2	Dehumid	Electric Heat	Setting	Fan Only	Waterside Economizer
015	4 (High)	0.7	500	565	470	565	A	500	500
	3 (Standard)		435	500	405	565	B	435	435
	2 (Medium)		375	435	375	565	C	375	375
	1 (Low)		375	375	375	565	D	280	375
019	4 (High)	0.7	600	675	560	675	A	600	600
	3 (Standard)		525	600	485	675	B	525	525
	2 (Medium)		450	525	450	675	C	450	450
	1 (Low)		450	450	450	675	D	335	450
024	4 (High)	0.7	800	900	750	900	A	800	800
	3 (Standard)		700	800	650	900	B	700	700
	2 (Medium)		560	700	560	900	C	560	560
	1 (Low)		560	560	560	900	D	450	560
030	4 (High)	0.7 (except * = 0.5)	1000	1075*	935	1075*	A	1000	1000
	3 (Standard)		875	1000	810	1075*	B	875	875
	2 (Medium)		750	875	750	1075*	C	750	750
	1 (Low)		750	750	750	1075*	D	560	750
036	4 (High)	0.7	1200	1350	1125	1350	A	1200	1200
	3 (Standard)		1050	1200	975	1350	B	1050	1050
	2 (Medium)		900	1050	900	1350	C	900	900
	1 (Low)		900	900	900	1350	D	670	900
042	4 (High)	0.7	1400	1575	1310	1575	A	1400	1400
	3 (Standard)		1225	1400	1135	1575	B	1225	1225
	2 (Medium)		1050	1225	1050	1575	C	1050	1050
	1 (Low)		1050	1050	1050	1575	D	785	1050
048	4 (High)	0.7	1600	1800	1500	1800	A	1600	1600
	3 (Standard)		1400	1600	1300	1800	B	1400	1400
	2 (Medium)		1200	1400	1200	1800	C	1200	1200
	1 (Low)		1200	1200	1200	1800	D	895	1200
060	4 (High)	0.7	2000	2250	1875	2250	A	2000	2000
	3 (Standard)		1750	2000	1625	2250	B	1750	1750
	2 (Medium)		1495	1750	1495	2250	C	1495	1495
	1 (Low)		1495	1495	1495	2250	D	1120	1495
070	4 (High)	0.7 (except * = 0.5)	2300	2450*	2155	2450*	A	2300	2300
	3 (Standard)		2010	2300	1865	2450*	B	2010	2010
	2 (Medium)		1720	2010	1720	2450*	C	1720	1720
	1 (Low)		1720	1720	1720	2450*	D	1290	1720

Table 28: I/O Expansion Module Jumper Configuration

I/O Expansion module configuration		
Setting	JP1	JP2
A	Open	Open
B	Shorted	Open
C	Open	Shorted
D	Shorted	Shorted

Figure 37: JP1 & JP2 Location On The I/O Expansion Module

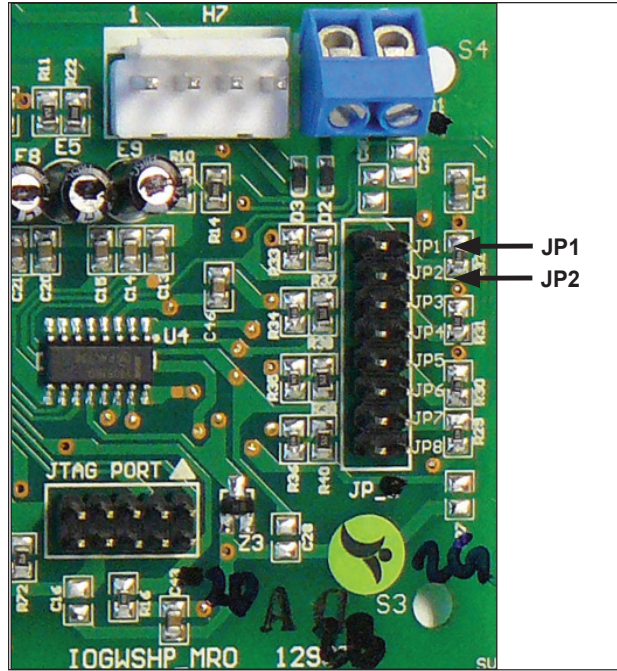

Jumper Settings on I/O Expansion Module

In addition to the 4-position switch, all units have the capability to set CFM values independent to those associated with compressor operation. Independent CFM values can be set for fan only, dehumidification, waterside economizer and hydronic heat from the jumper pins JP1 and JP2 on the I/O expansion module. The jumper pin configurations represent settings A, B, C and D. See [Table 28](#). These settings establish unique CFM settings for the four previously mentioned mode of operation. See [Table 25 on page 46](#) and [Table 27 on page 48](#) under the I/O Expansion Module. For example, unit size 036 with the 4-position switch set at Setting #3 and the I/O expansion module jumper set at B, will deliver 1200 CFM at stage 2 compressor operation mode, 1050 CFM at stage 1 compressor operation, 1350 CFM in electric heat mode, 1050 CFM in fan only mode, 975 CFM in dehumidification mode, 1050 CFM in hydronic heat mode and 1050 CFM in waterside economizer mode.

Table 29: Standard CFM Settings

Unit Size 024	Standard CFM Settings (Compressor is ON)		
Fan Setting	High CFM Cooling Stage 3	Low CFM Cooling Stage 2	Dehumidification Mode Stage 1
#3	800	700	650

Fan Speed Selector Switch

A 4-position fan speed selector switch located in the control box allows maximum CFM settings to be field adjustable. Fan speed control optimizes unit fan speed (CFM) based on thermostat/room sensor inputs. The fan speed switch allows for manually setting an optimal CFM specific to the application requirements. Each position on the fan speed switch represents settings 1-4. See [table 14 on page 61](#) for the complete list of fan speed selector switch settings.

Figure 38: 4-Position Fan Speed Selector Switch

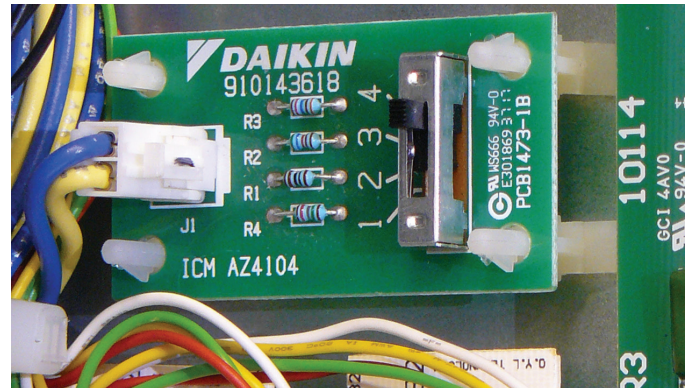

Variable CFM

All units have the capability to deliver variable CFM based on the thermostat wiring. By using a multi-stage wall thermostat, the unit can deliver lower CFM as the space temperature is satisfied. For example, unit size 024 with the 4-position switch set a #3, I/O expansion module JP1/JP2 jumpers set at B and a 3-stage cooling wall thermostat will deliver 650 CFM at stage 1 cooling, 700 CFM at stage 2 cooling and 800 CFM at stage 3 cooling. All of this is accomplished by wiring the thermostat to the appropriate terminal on the MicroTech III controller terminal strip. The variable CFM feature allows for improved humidity levels by increasing latent cooling capacity through reduced CFM. Here, we are attempting to satisfy cooling at the lowest airflow, 650 CFM, but having the capability to deliver higher airflow, 800 CFM, if needed.

Initial Start-up

CAUTION

Units must be checked for water leaks upon initial water system start-up. Water leaks may be a result of mishandling or damage during shipping. Failure by the installing contractor to check for leaks upon start-up of the water system could result in property damage.

Check, Test & Start Procedure

NOTICE

Complete the "Water Source Heat Pump Equipment Check, Test and Start Form" on page 38.

Check As Completed:

- Open all valves to full open position and turn on power to the unit.
 - Set thermostat for "Fan Only" operation by selecting "Off" at the system switch and "On" at the fan switch. If "Auto" fan operation is selected, the fan will cycle with the compressor. Check for proper air delivery.
 - Set thermostat to "Cool." If the thermostat is an automatic changeover type, simply set the cooling temperature to the coolest position. On manual changeover types additionally select "Cool" at the system switch.
Again, many units have time delays which protect the compressor(s) against short cycling. After a few minutes of operation, check the discharge grilles for cool air delivery. To insure proper water flow, measure the temperature difference between entering and leaving water. The temperature differential should be 10°F to 14°F (5°C to 8°C) for units in cooling mode. It should be approximately 1½ times greater than the heating mode temperature difference. For example, if the cooling temperature difference is 15°F (8°C), the heating temperature difference should have been 10°F (5°C).
Without automatic flow control valves, target a cooling temperature difference of 10°F to 14°F (5°C to 8°C). Adjust the combination shutoff/balancing valve in the return line to a water flow rate which will result in the 10°F to 14°F (5°C to 8°C) difference
- Set thermostat to "Heat." If the thermostat is the automatic changeover type, set system switch to the "Auto" position and depress the heat setting to the warmest selection. Some units have built-in time delays which prevent the compressor from immediately starting. With most control schemes, the fan will start immediately. After a few minutes of compressor operation, check for warm air delivery at discharge grille. If this is a "cold building" start-up, leave unit running until return air to the unit is at least 65°F (18°C).
Measure the temperature difference between entering and leaving air and entering and leaving water. With entering water of 60°F to 80°F (16°C to 27°C), leaving water should be 6°F to 12°F (3.3°C to 6.6°C) cooler, and the air temperature rise through the machine should not exceed 35°F (19°C). If the air temperature exceeds 35°F (19°C), then the water flow rate is inadequate.
 - Check the elevation and cleanliness of the condensate line. If the air is too dry for sufficient dehumidification, slowly pour enough water into the condensate pan to ensure proper drainage.
 - If the unit does not operate, check the following points:
 - a. Is supply voltage to the machine compatible?
 - b. Is thermostat type appropriate?
 - c. Is thermostat wiring correct?
 - If the unit operates but stops after a brief period:
 - a. Is there proper airflow? Check for dirty filter, incorrect fan rotation (3-phase fan motors only), or incorrect ductwork.
 - b. Is there proper water flow rate within temperature limits? Check water balancing; back flush unit if dirt-clogged.
 - Check for vibrating refrigerant piping, fan wheels, etc.

Operating Limits

Environment

This equipment is designed for indoor installation only. Sheltered locations such as attics, garages, etc., generally will not provide sufficient protection against extremes in temperature and/or humidity, and equipment performance, reliability, and service life may be adversely affected.

NOTICE

ALTITUDE LIMITS

Maximum applied altitude not to exceed 3,000 meters

Air Limits

Table 30: Air Limits in °F (°C)

Air Limits	Standard Range Units		Extended Range (Geothermal) Units	
	Cooling (DB/WB)	Heating	Cooling (DB/WB)	Heating
Minimum Ambient Air ¹	50°F (10°C)	50°F (10°C)	40°F (4°C)	40°F (4°C)
Maximum Ambient Air ²	100°F/77°F (38°C/25°C)	85°F (29°C)	100°F/77°F (38°C/25°C)	85°F (29°C)
Minimum Entering Air ¹	65°F/55°F (18°C/13°C)	50°F (10°C)	65°F/55°F (18°C/13°C)	50°F (10°C)
Common Design Entering Air	75°F/63°F (24°C/17°C)	70°F (21°C)	75°F/63°F (24°C/17°C)	70°F (21°C)
Maximum Entering Air ²	85°F/71°F (29°C/22°C)	80°F (27°C)	85°F/71°F (29°C/22°C)	80°F (27°C)

Fluid Limits

Table 31: Fluid Limits

Fluid Limits	Standard Range Units		Extended Range (Geothermal) Units	
	Cooling	Heating	Cooling	Heating
Minimum Entering Fluid	55°F (13°C)	55°F (13°C)	30°F (-1°C)	20°F (-6°C)
Common Design Entering Fluid	85-90°F (29-32°C)	70°F (21°C)	90°F (32°C)	35-60°F (1.5-16°C)
Maximum Entering Fluid	120°F (43°C)	90°F (32°C)	120°F (43°C)	90°F (32°C)
Minimum GPM/Ton	1.5			
Nominal GPM/Ton	3.0			
Maximum GPM/Ton	4.0			

Notes: 1. Maximum and minimum values may not be combined. If one value is at maximum or minimum, the other two conditions may not exceed the normal condition for standard units. Extended range units may combine any two maximum conditions, but not more than two, with all other conditions being normal conditions.
 2. This is not a normal or continuous operating condition. It is assumed that such a start-up is for the purpose of bringing the building space up to occupancy temperature.

Field-Installed Accessory

Motorized Isolation Valve

The motorized valve kit is available as a factory-installed or a field-installed option.

Wired as shown in Figure 39, the motorized valve will open on a call for compressor operation.

The motorized isolation valve actuator (ISO) has both a 24V power connection and a 24V end switch connection.

Install the supplied wire harness into plug H8 on the main control board. Run wires between the ISO actuator and the supplied wire harness ends.

Connect N.O. & N.C. actuators as shown on the schematic. The end switch should be wired in series with the 24V compressor signal wire. Connect the end switch wires as shown in the schematic. The end switch will close when the valve is fully open.

Note: For detailed installation instructions for the motorized valve, refer to IM 1151.

Figure 39: Motorized Valve Wiring

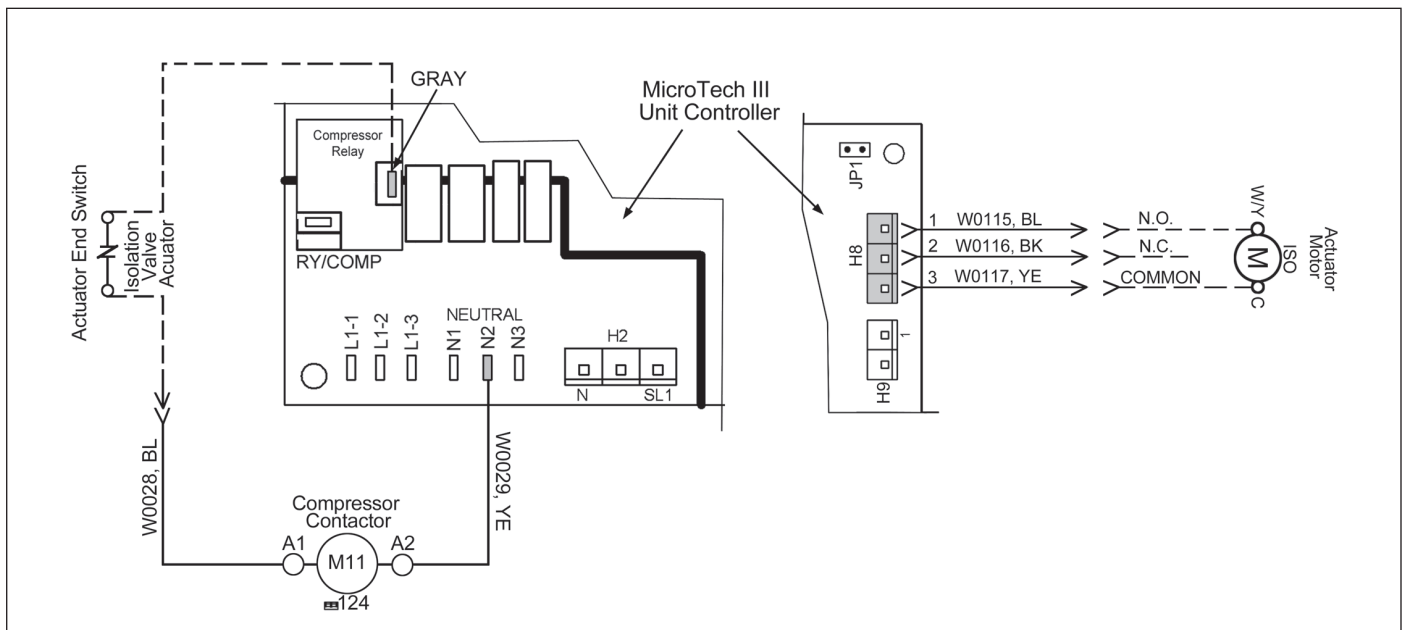

Control Wiring Schematics

MicroTech III Unit Control with PSC Motor - 208-230, 265, 460, 575 Volt

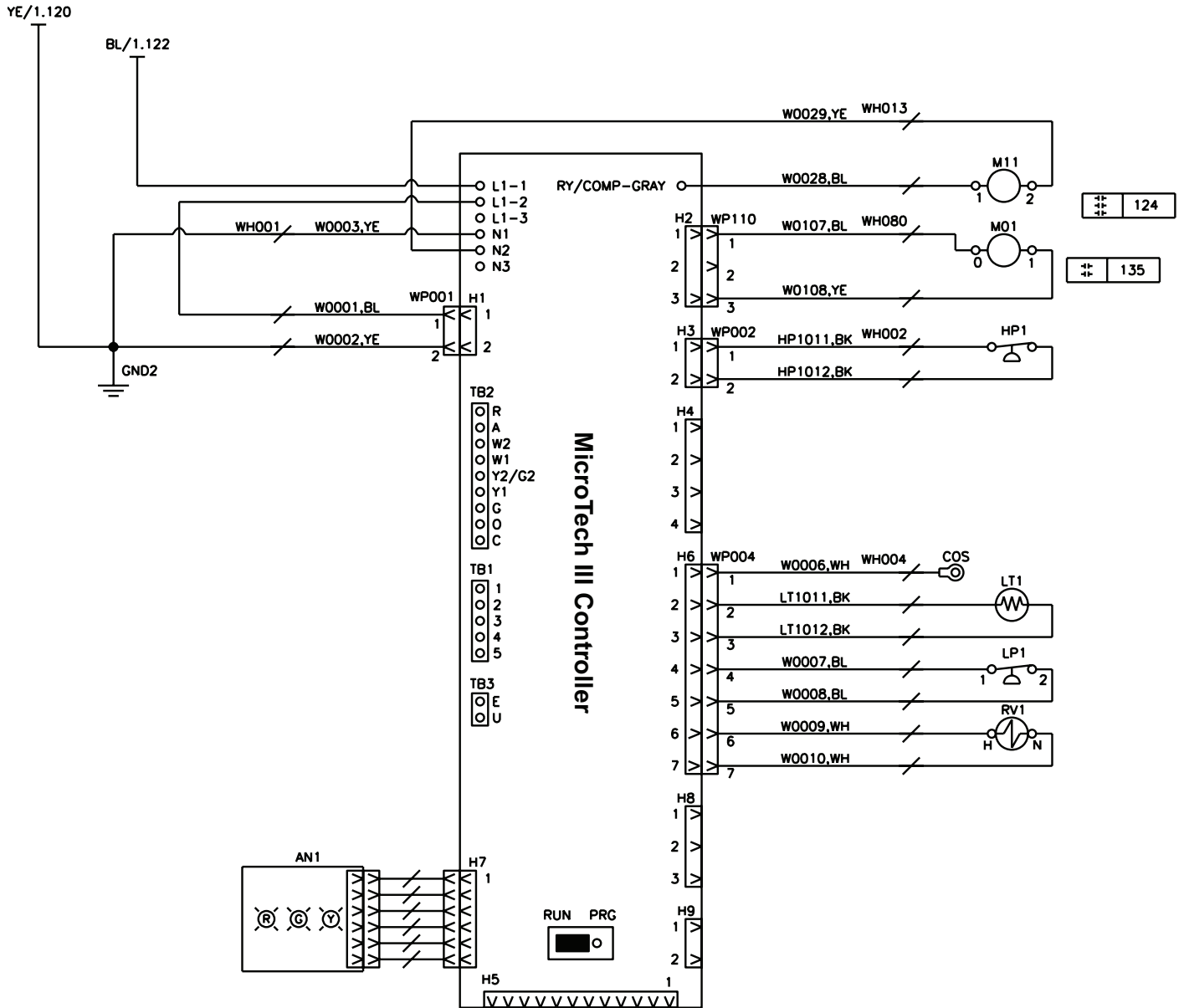

MicroTech III Unit Control with Constant Torque EC Motor - 115 Volt - No Options

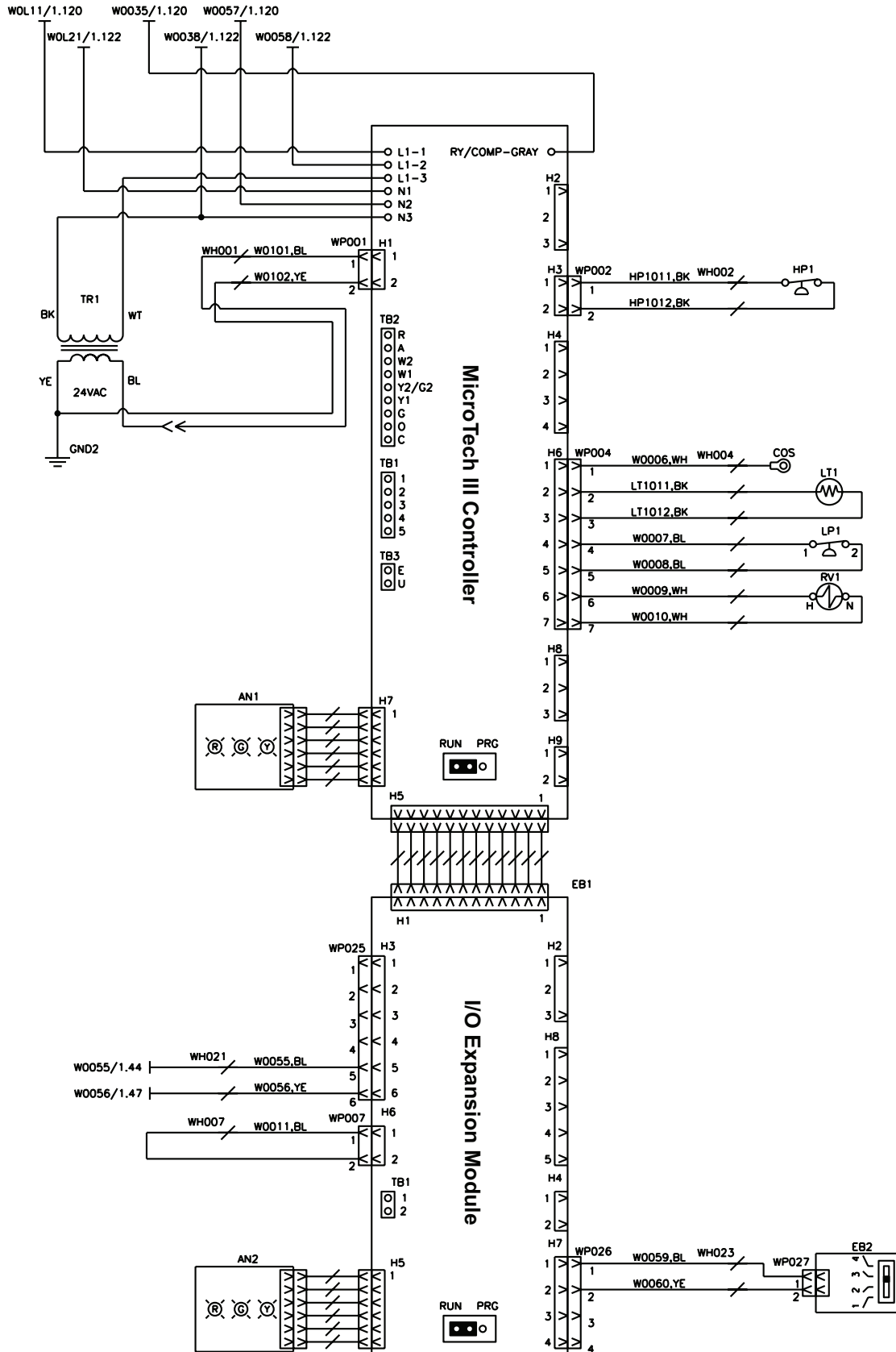

MicroTech III Unit Control with Constant Torque EC Motor with Waterside Economizer

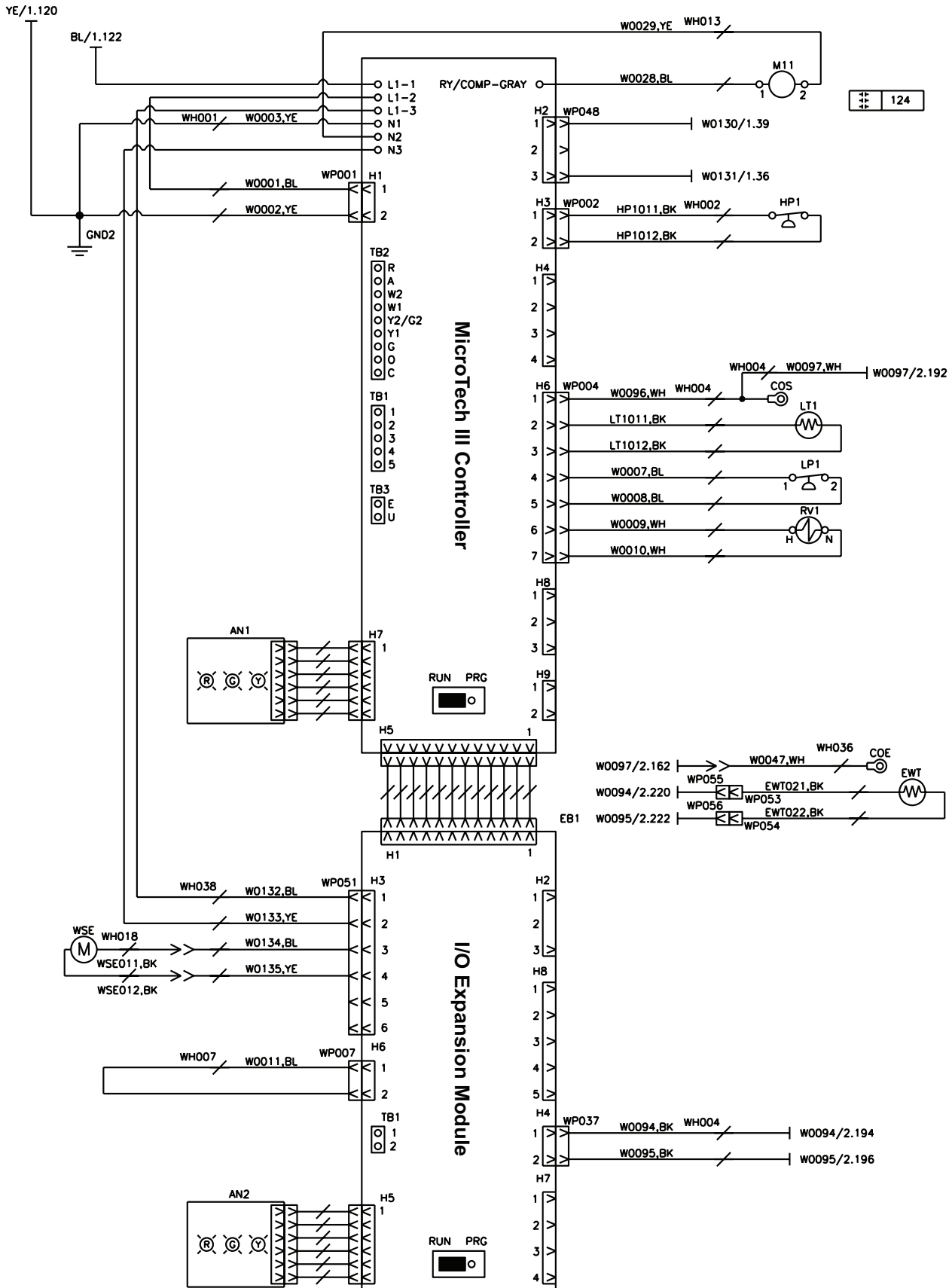

MicroTech III Unit Control with Constant CFM EC Motor with Hot Gas Reheat

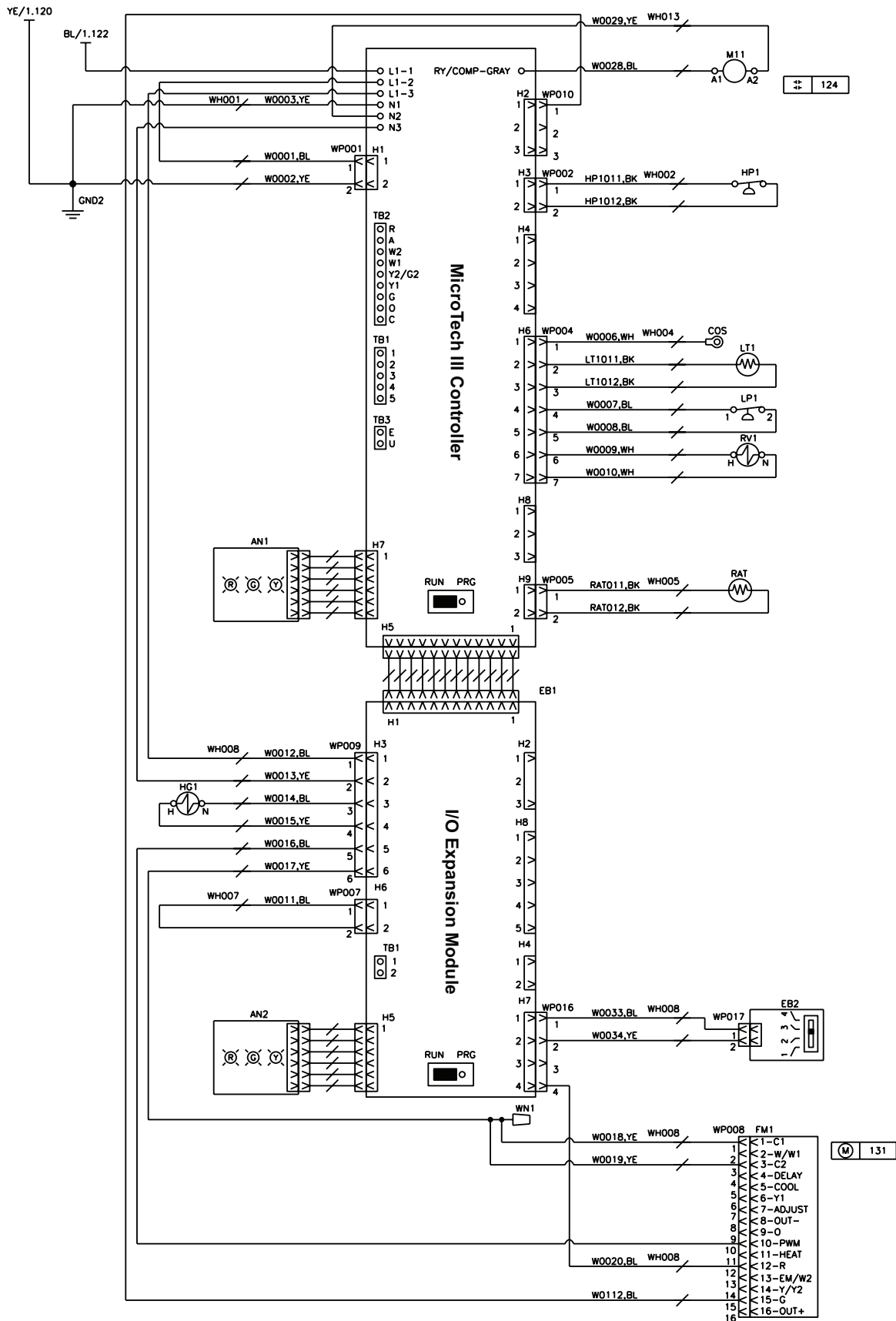

MicroTech III Unit Control with Constant CFM EC Motor - 2-Stage Unit

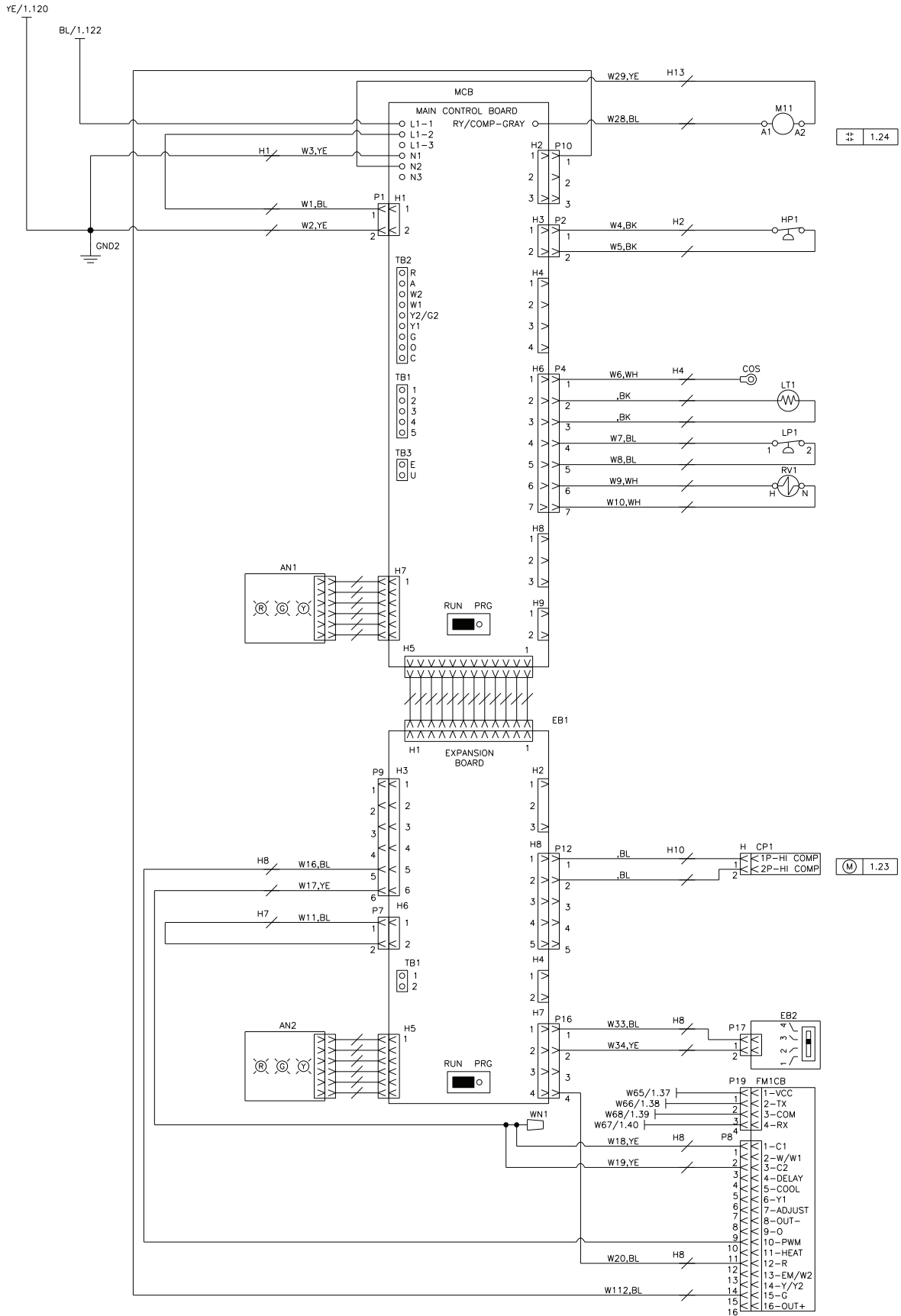

MicroTech III Unit Control with Constant CFM EC Motor with Electric Heat Control Wiring

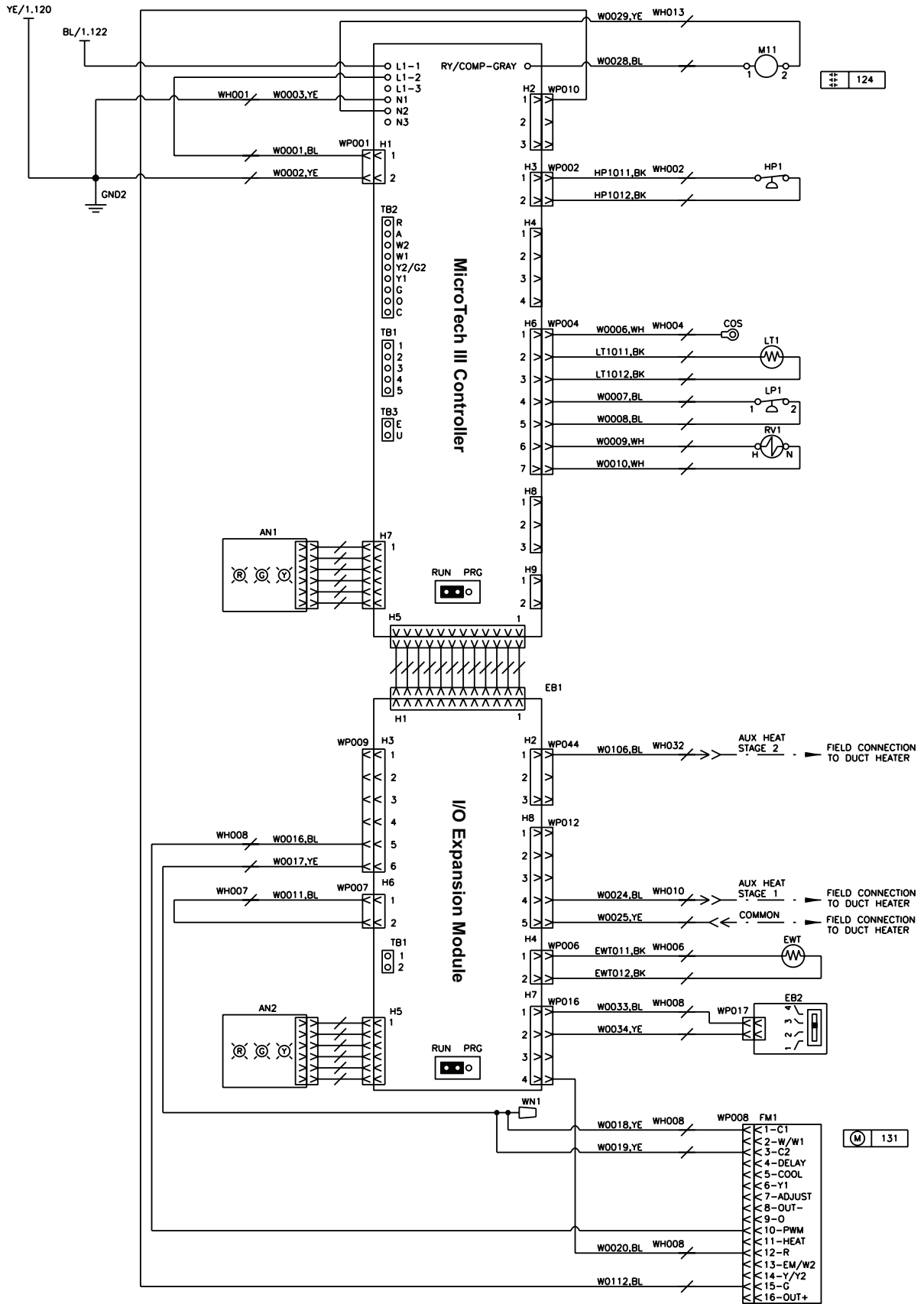

MicroTech III Unit Control with Constant CFM EC Motor with BACnet Communication Module

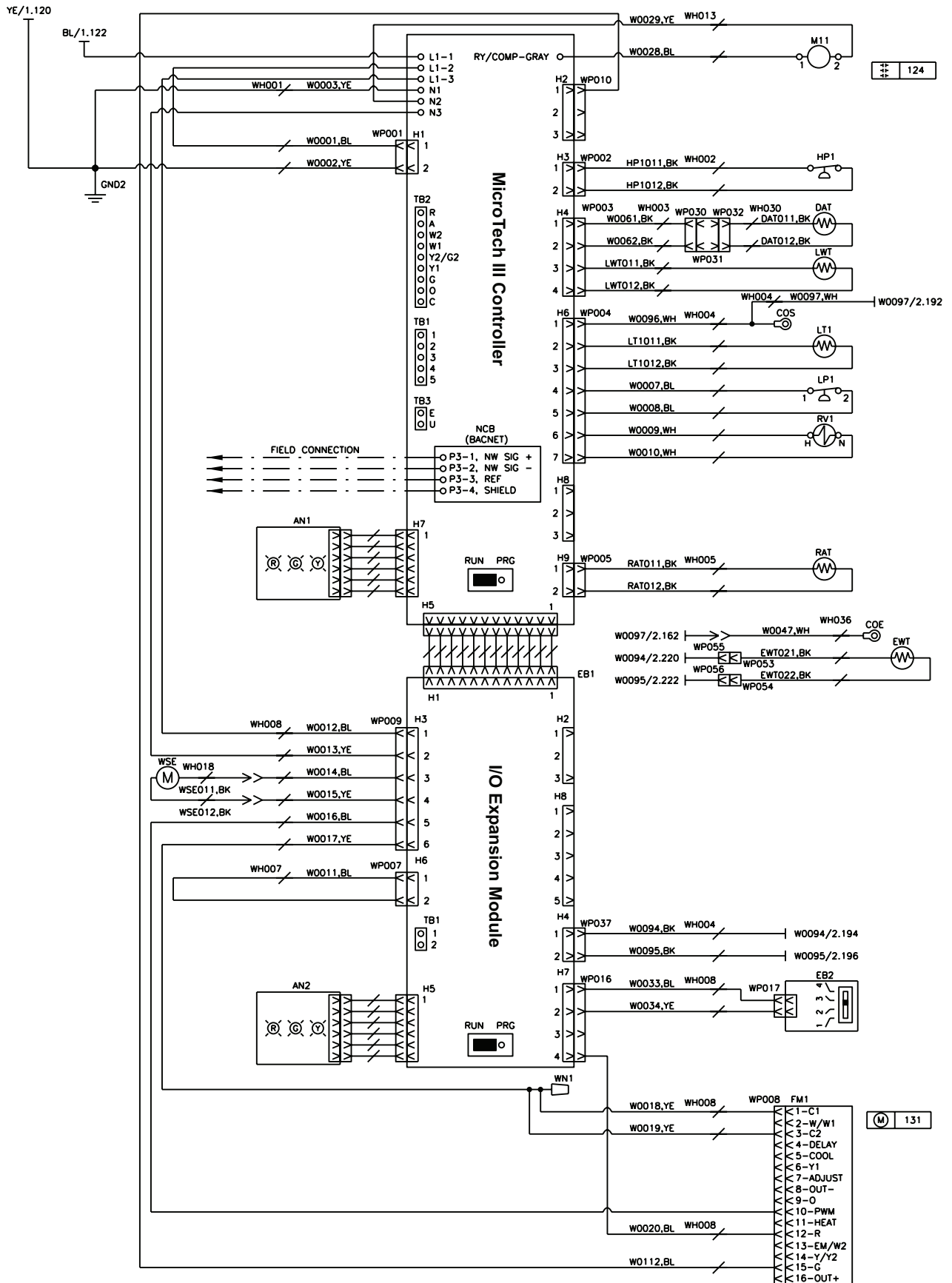

Line Voltage Wiring Schematics

115V/60Hz/1Ph With PSC Motor

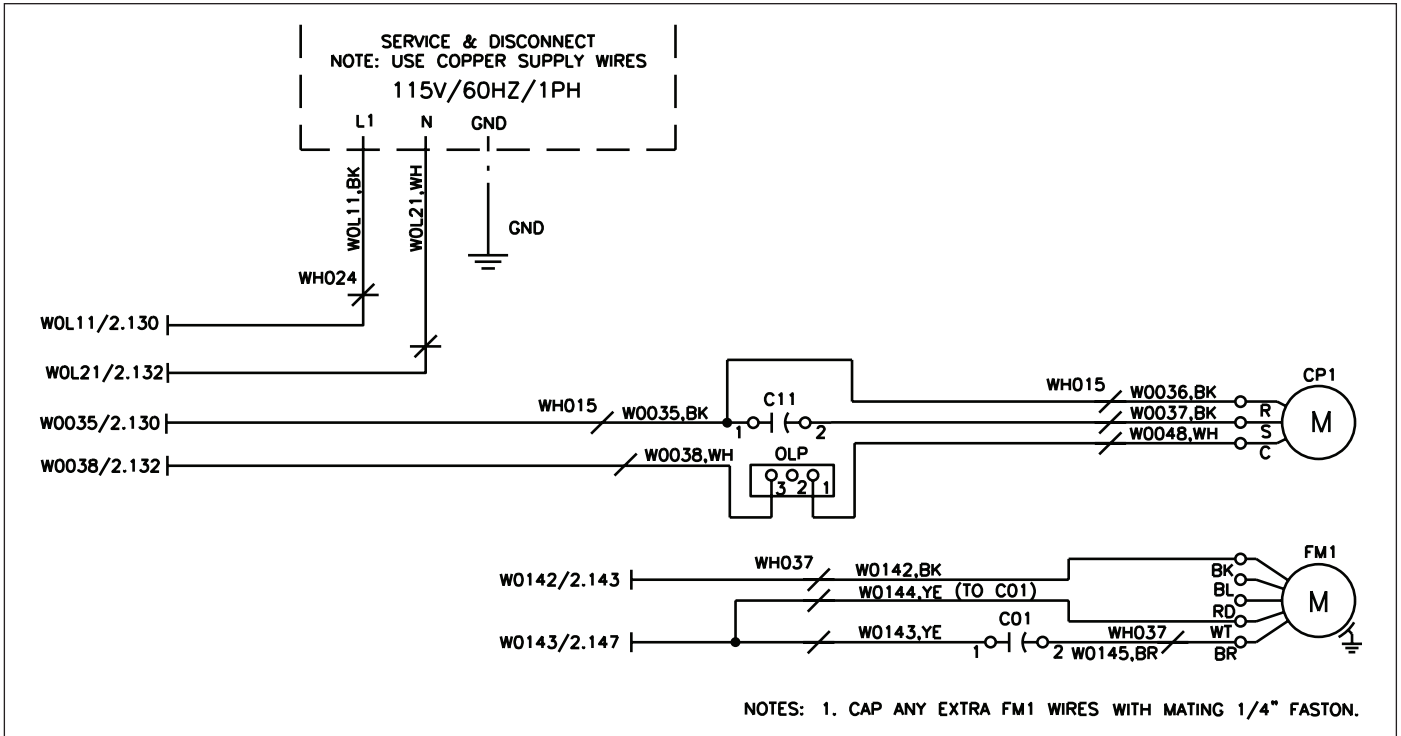

115V/60Hz/1Ph With Constant Torque EC Motor

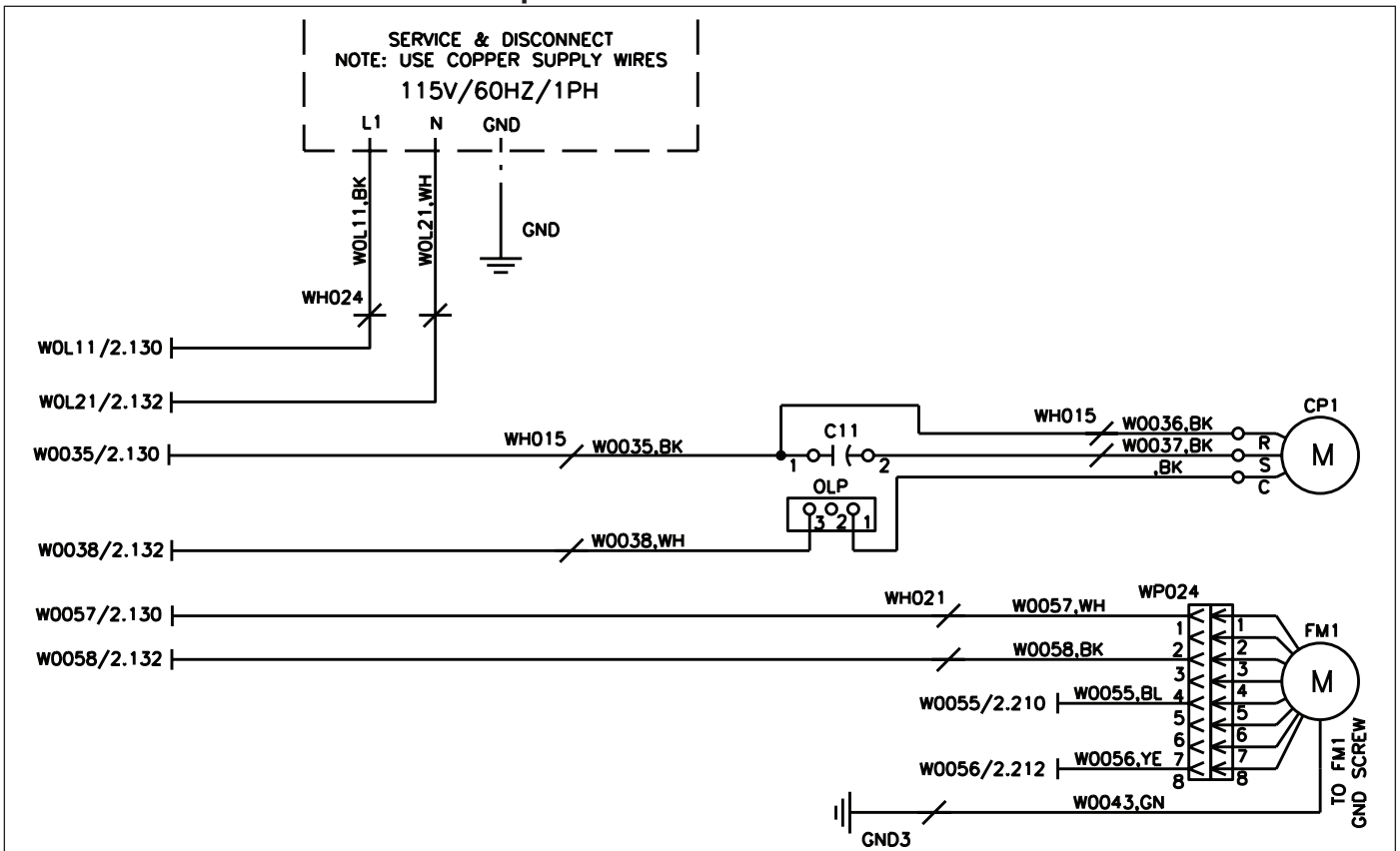

265V/60Hz/1Ph With Constant Torque EC Motor

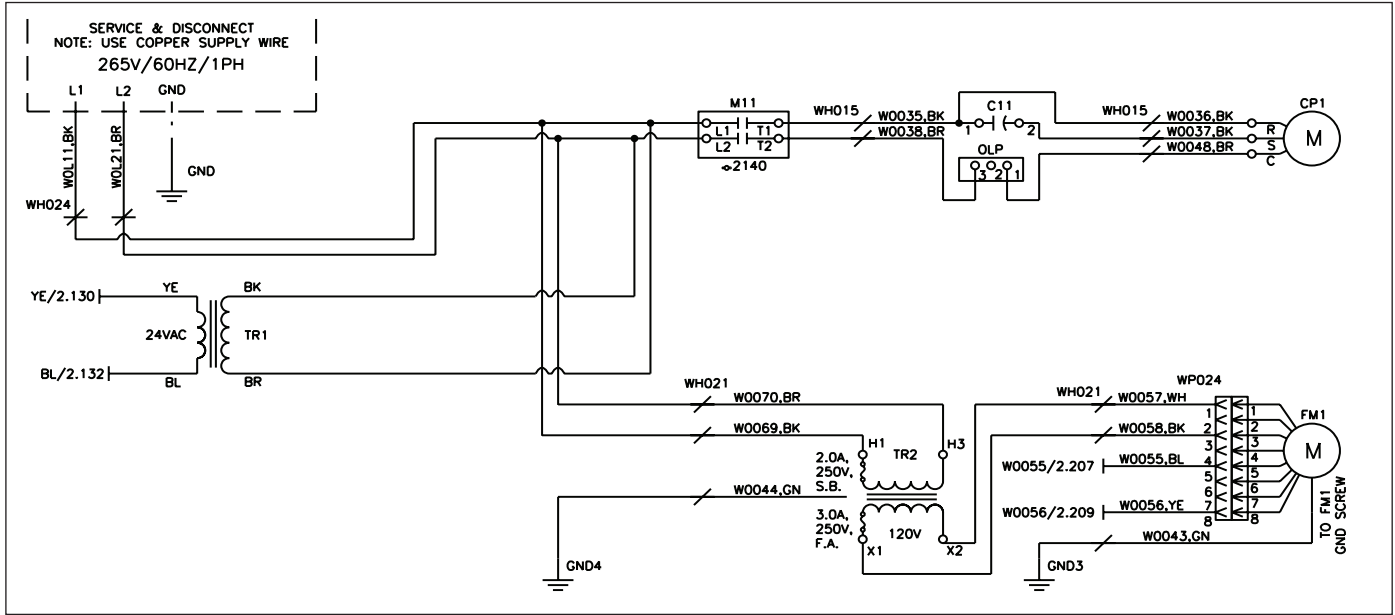

208-230V/60Hz/3Ph With Constant Torque EC Motor

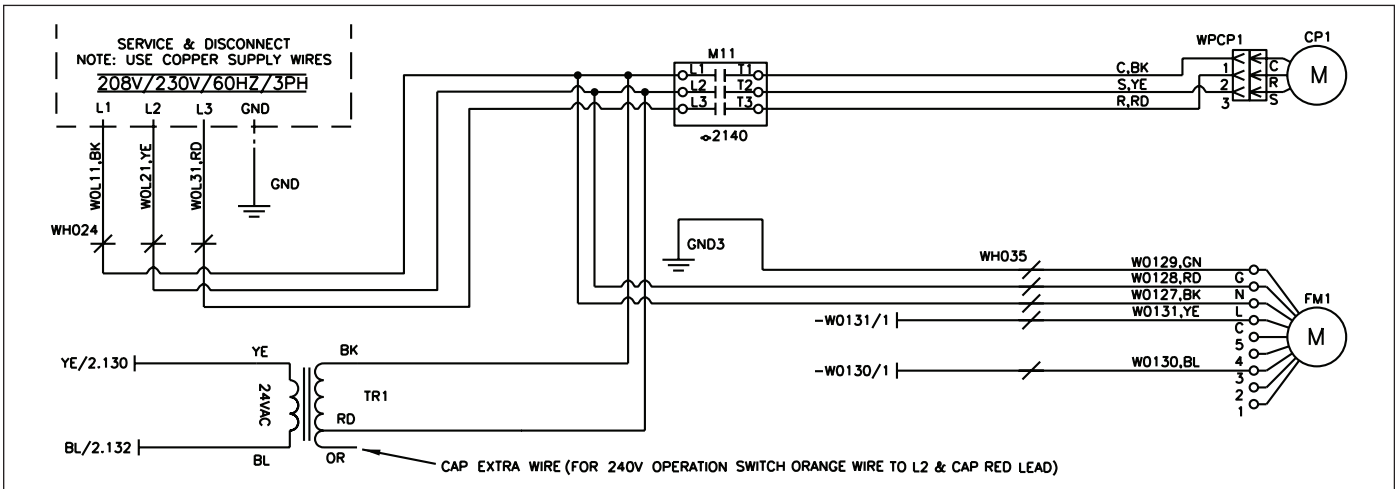

265-277V/60Hz/1Ph, 208-230V/60Hz/1Ph With PSC Motor

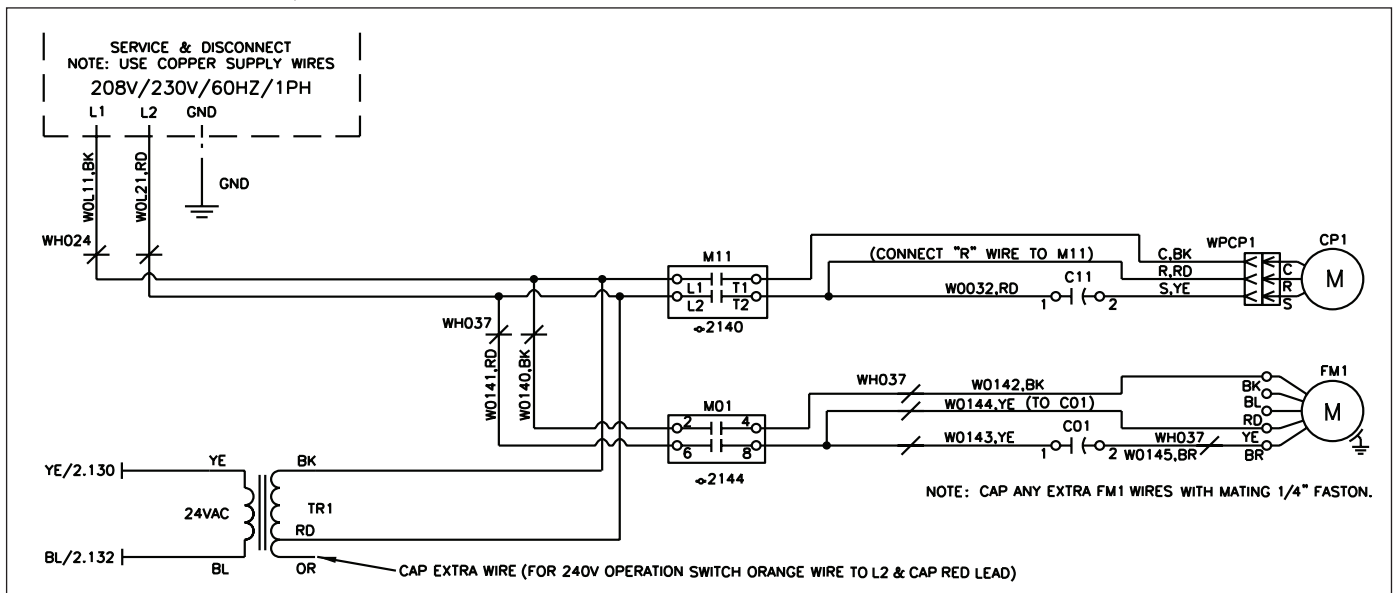

460V/60Hz/3Ph, 575V/60Hz/3Ph, 208-230V/60Hz/3Ph With PSC Motor

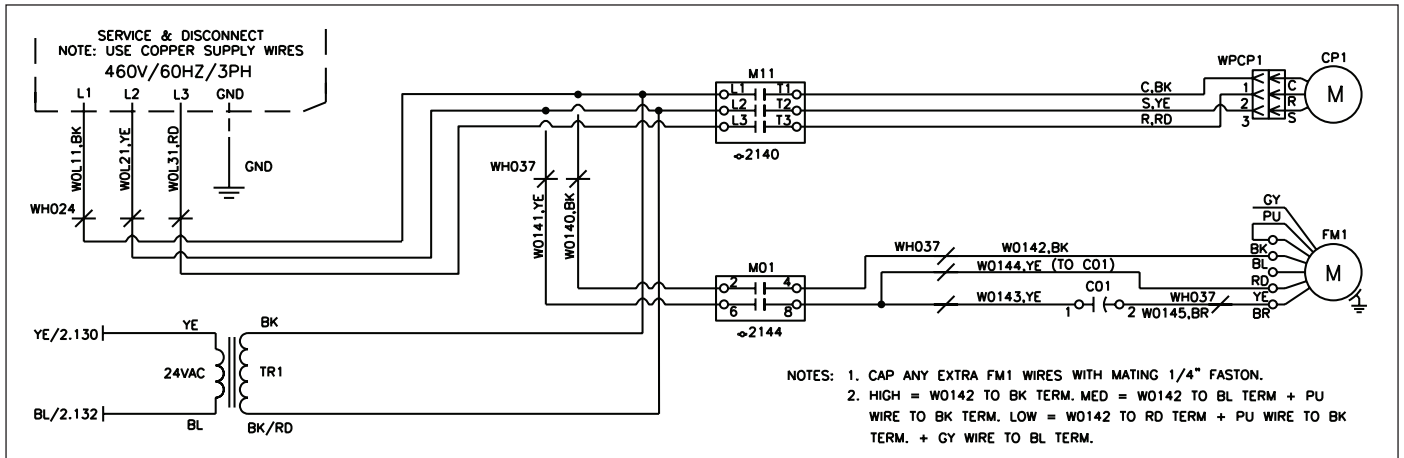

208-230V/60Hz/3Ph, With Constant CFM EC Motor

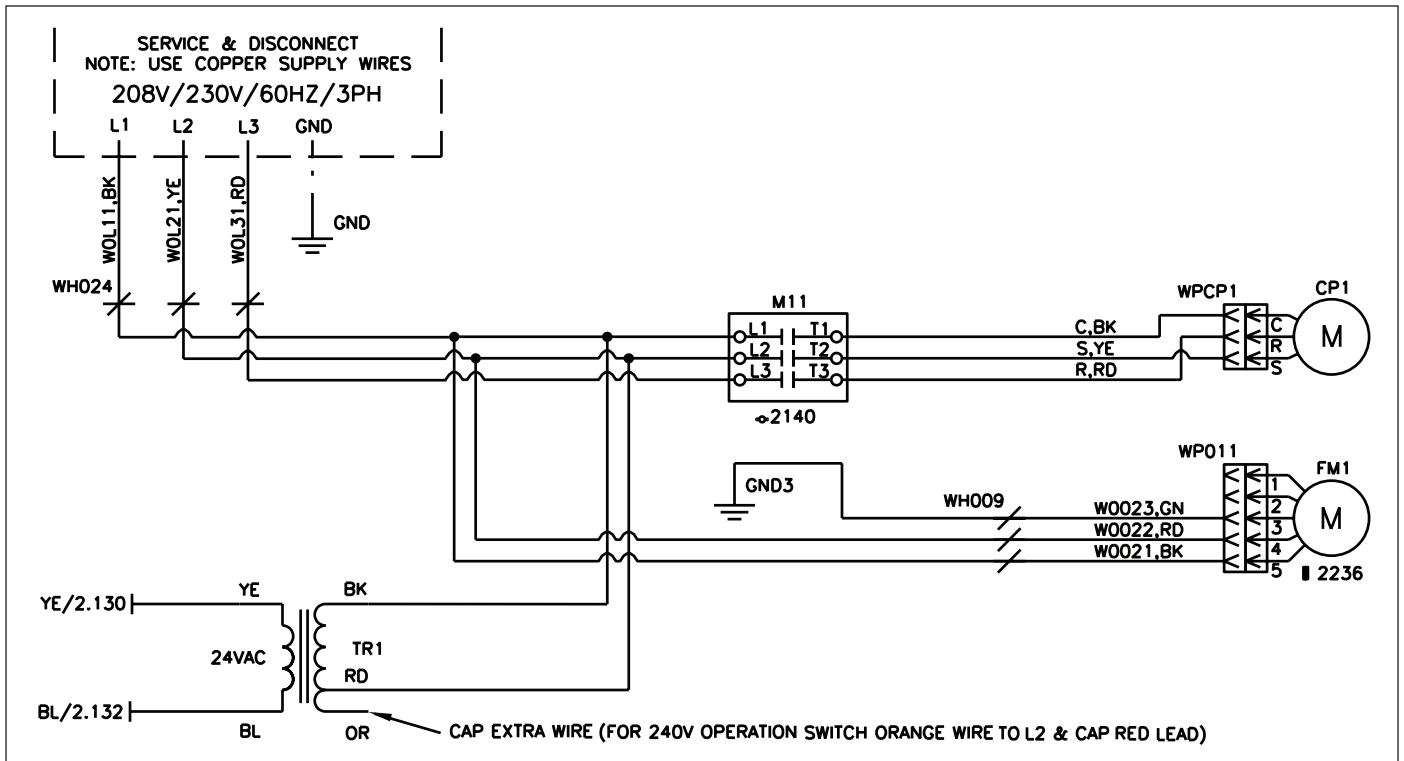

460V/60Hz/3Ph With Constant CFM EC Motor

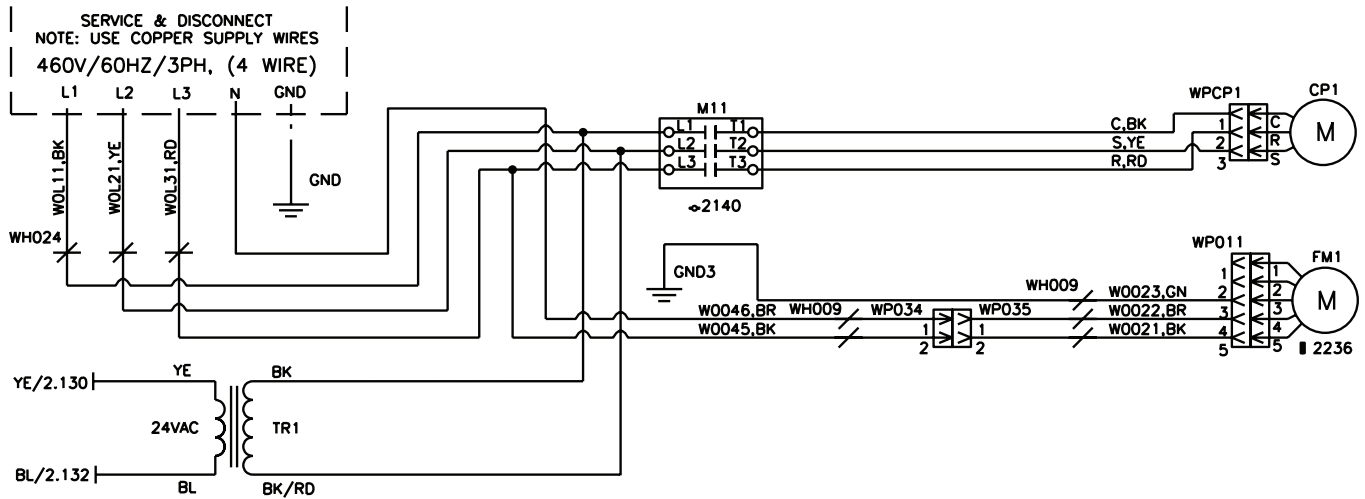

Wiring Schematics Legend

Note: Devices in legend may or may not be on unit.

- | | | | |
|--------|---|-------|--|
| AN1, 2 | LED Annunciator | LP1 | Low Pressure Switch |
| CO1 | Fan Motor 1 Capacitor | LT1 | Compressor Suction Line Temperature Sensor |
| C11 | Compressor 1 Capacitor | LWT | Leaving Water Temperature Sensor |
| CP1 | Compressor 1 | M01 | Fan Motor Contactor |
| COE | Condensate Overflow Protection Sensor - WSE | M11 | Compressor 1 Contactor |
| COS | Condensate Overflow Protection Sensor | MCB | Main Control Board |
| DAT | Discharge Air Temperature Sensor | NCB | Network Control Board |
| DCS | Disconnect Switch | OLP | Overload Protector - Compressor Motor |
| EB1 | Expansion Control Board 1 | RAT | Return Air Temperature Sensor |
| EB2 | Expansion Control Board 2 - fan speed ctrl | RV1 | Reversing Valve |
| EWT | Entering Water Temperature Sensor | TR1 | Transformer - Control |
| FM1 | Fan Motor 1 | TR2 | Transformer - Fan Motor |
| GND | Ground | W0001 | Wire |
| HG1 | Hot Gas Reheat Valve Actuator | WH001 | Wire Harness |
| HP1 | High Pressure Switch | WN1 | Wire Nut |
| HYH | Hot Water Heat Valve Actuator | WP001 | Wire Plug |
| LAT | Leaving Air Temperature Sensor | WSE | Waterside Economizer Actuator |

General Maintenance

1. Normal maintenance on all units is generally limited to filter changes. Units are provided with permanently lubricated motors and require no oiling even though oil caps may be provided.
2. Filter changes are required at regular intervals. The time period between changes will depend upon the project requirements. Some applications such as motels produce a lot of lint from carpeting and linen changes, and will require more frequent filter changes. Check filters at 60-day intervals for the first year until experience is acquired. If light cannot be seen through the filter when held up to sunlight or a bright light, it should be changed. A more critical standard may be desirable.
3. The condensate drain pan should be checked annually and cleaned and flushed as required.
4. Record performance measurements of volts, amps, and water temperature differences (both heating and cooling). A comparison of logged data with start-up and other annual data is useful as an indicator of general equipment condition.
5. Periodic lockouts almost always are caused by air or water problems. The lockout (shutdown) of the unit is a normal protective result. Check for dirt in the water system, water flow rates, water temperatures, airflow rates (may be a dirty filter), and air temperatures. If the lockout occurs in the morning following a return from night setback, entering air below machine limits may be the cause.

Lubrication

R-410A should be used only with polyester (POE) oil. The HFC refrigerant components in R-410A will not be compatible with mineral oil or alkylbenzene lubricants. R-410A systems will be charged with the OEM recommended lubricant, ready for use with R-410A.

Charging

Due to the zeotropic nature of R-410A, it should be charged as a liquid. In situations where vapor is normally charged into a system, a valve should be installed in the charging line to flash the liquid to vapor while charging.

Note: *Because a water source heat pump operates under a wide range of water and air temperatures, the values printed below are to be taken as suggested pressure and temperatures. All Daikin water source heat pumps are designed for commercial use. The units are designed for both heating and cooling operation and fail safe to cooling. The reversing valve is energized for the heating mode of operation*

Superheat	Head Pressure	Water Delta T
8 to 14 degrees	335-355 PSIG	10° to 14°

- Notes:** 1. All information above is based on ISO standard 13256-1 and tested at these conditions.
 2. Operating conditions shall be within the limits established in Table 30, and Table 31 on page 52.

Figure 40: Disassemble Motor Orifice Ring and Motor Mount Screws From Fan Housing

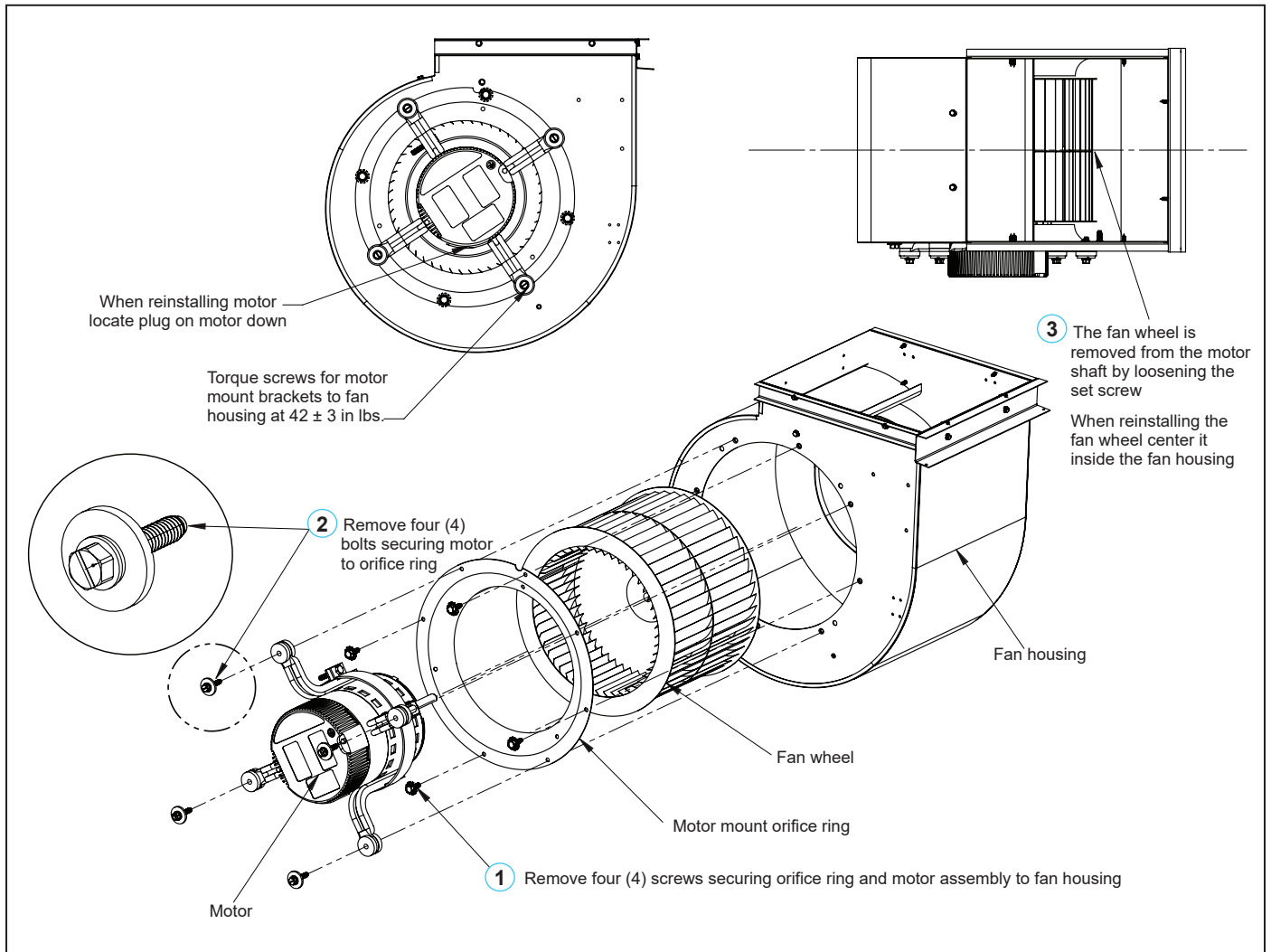

Troubleshooting

Table 32: Troubleshooting Refrigeration Circuit

Symptom	Head Pressure	Suction Pressure	Compressor Amp Draw	Super Heat	Subcooling	Air Temp Differential	Water (Loops) Temp Differential	Safety Lock Out
Charge								
Undercharge System (Possible Leak)	Low	Low	Low	High	Low	Low	Low	Low Pressure
Overcharge System	High	High	High	Normal	High	Normal Low	Normal	High Pressure
Low Air Flow Heating	High	High	High	High Normal	Low	High	Low	High Pressure
Low Air Flow Cooling	Low	Low	Low	Low Normal	High	High	Low	Low Temp
Low Water Flow Heating	Low Normal	Low Normal	Low	Low	High	Low	High	Low Temp
Low Water Flow Cooling	High	High	High	High	Low	Low	High	High Pressure
High Air Flow Heating	Low	Low	Low	Low	High	Low	Low	Low Temp
High Air Flow Cooling	Low	High	Normal	High	Low	Low	Normal	High Pressure
High Water Flow Heating	Normal	Low	Normal	High	Normal	Normal	Low	High Pressure
High Water Flow Cooling	Low	Low	Low	Low	High	Normal	Low	Low Temp
TXV Restricted	High	Low	Normal Low	High	High	Low	Low	

Typical Refrigeration Cycles

Figure 41: Cooling Mode

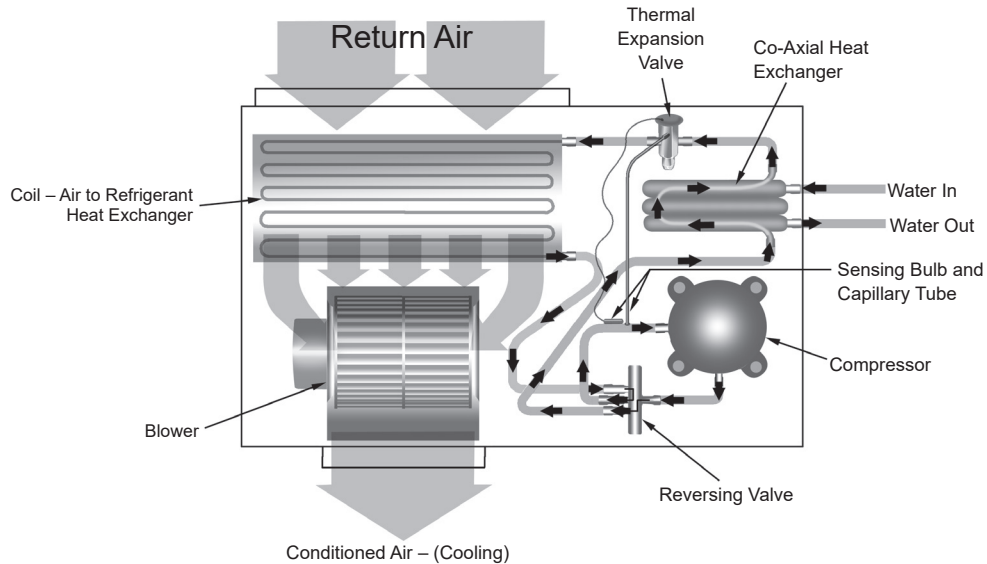

Cooling Refrigeration Cycle

When the wall thermostat is calling for COOLING, the reversing valve is de-energized and directs the flow of the refrigerant (hot gas) leaving the compressor to the water-to-refrigerant heat exchanger. Here the heat is removed by the water and the hot gas condenses to become a liquid. The liquid then flows through a thermal expansion valve (TXV) and then to the air-to-refrigerant heat exchanger coil. The liquid then evaporates becoming a gas, at the same time absorbing heat and cooling the air passing over the surfaces of the coil. The refrigerant then flows as a low pressure gas through the reversing valve and back to the suction side of the compressor to complete the cycle.

Figure 42: Heating Mode

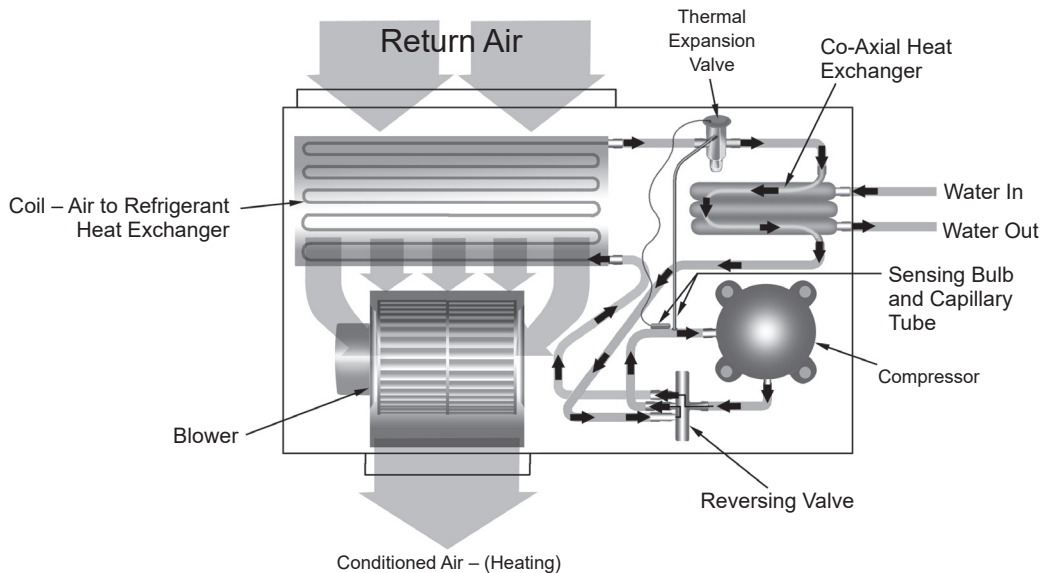

Heating Refrigeration Cycle

When the wall thermostat is calling for HEATING, the reversing valve is energized and directs the flow of the refrigerant (hot gas) leaving the compressor to the air-to-refrigerant heat exchanger coil. Here the heat is removed by the air passing over the surfaces of the coil and the hot gas condenses to become a liquid. The liquid then flows through a thermal expansion valve (TXV) then to the water-to-refrigerant heat exchanger. The liquid then evaporates becoming a gas, at the same time absorbing heat and cooling the water. The refrigerant then flows as a low pressure gas through the reversing valve and back to the suction side of the compressor to complete the cycle.



Unit Check / Equipment Data

Installation Data

Job Name _____ Check Test Date: _____

City _____ State _____ Zip _____

Daikin Model # _____

Daikin Serial # _____ Job site Unit ID # (HP #) _____

General Contractor: _____ Mechanical Contractor: _____

Technician Performing Start-Up: Name _____ Employer: _____

Complete equipment data from measurements taken at the locations indicated on the drawing below.

Equipment Data

Flow Rate **EWP - LWP = ΔP**

① EWP - PSI In _____ minus ② LWP - PSI Out _____ equals ΔP _____

The first step in finding GPM is to subtract leaving water pressure from entering water pressure. The difference between the two is referred to as ΔP. ΔP can be converted to GPM by looking in the equipment specification catalog. **Caution ΔP ≠ GPM**

Note: A conversion table must be used to find GPM from (Delta) ΔP measurements.

Loop Fluid Temperature Rise / Drop through Coaxial Heat Exchanger **EWT - LWT = ΔT**

③ EWT - °F Out _____ minus ④ LWT - °F Out _____ equals Fluid ΔT _____

ΔT is the rise or drop in the fluid temperature as it passes through the Coaxial.

Air Temperature Rise / Drop through the air coil **ΔT x CFM x 1.08 = BTUH Sensible**

⑤ EAT - °F In _____ minus ⑥ LAT - °F Out _____ equals Air ΔT _____

Note: Perform Check, Test and Start-Up in the Cooling Mode Only.

EWT - Entering Water Temperature EWP - Entering Water Pressure EAT - Entering Air Temperature Δ- Delta (Differential)
 LWT - Leaving Water Temperature LWP - Leaving Water Pressure LAT - Leaving Air Temperature CFM - Cubic Feet/Minute
 BTUH - British Thermal Units/Hour

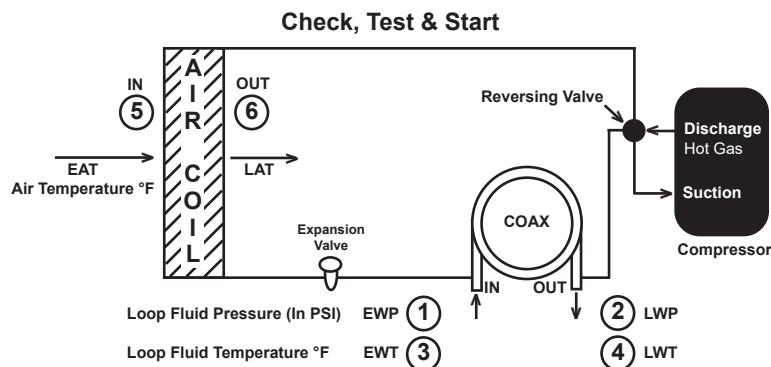

Form No. _____



Commercial Check, Test and Start Worksheet

(Complete all equipment measurements indicated for each unit per installation on previous page)

Model	Serial #	H.P. #	EWT ③	LWT ④	EWP ①	LWP ②	EAT ⑤	LAT ⑥	Volts	Amps Cool- ing	Check Air Filter and Coil	Comments
1.												
2.												
3.												
4.												
5.												
6.												
7.												
8.												
9.												
10.												
11.												
12.												
13.												
14.												
15.												
16.												
17.												
18.												
19.												
20.												
21.												
22.												
23.												
24.												
25.												
26.												
27.												
28.												
29.												
30.												
31.												
32.												
33.												
34.												
35.												
36.												
37.												
38.												
39.												
40.												
41.												
42.												

Part No. _____



Daikin Applied Training and Development

Now that you have made an investment in modern, efficient Daikin Applied equipment, its care should be a high priority. For training information on all Daikin Applied HVAC products, please visit us at www.DaikinApplied.com and click on Training, or call 540-248-9646 and ask for the Training Department.

Warranty

All Daikin Applied equipment is sold pursuant to its standard terms and conditions of sale, including Limited Product Warranty. Consult your local Daikin Applied representative for warranty details. Refer to Form 933-430285Y. To find your local Daikin Applied representative, go to www.DaikinApplied.com.

Aftermarket Services

To find your local parts office, visit www.DaikinApplied.com or call 800-37PARTS (800-377-2787). To find your local service office, visit www.DaikinApplied.com or call 800-432-1342.

This document contains the most current product information as of this printing. For the most up-to-date product information, please go to www.DaikinApplied.com.

Products manufactured in an ISO Certified Facility.