

ONE BEAM 19B1

SHOP NOTE:  
CAMBER 1/2 UP

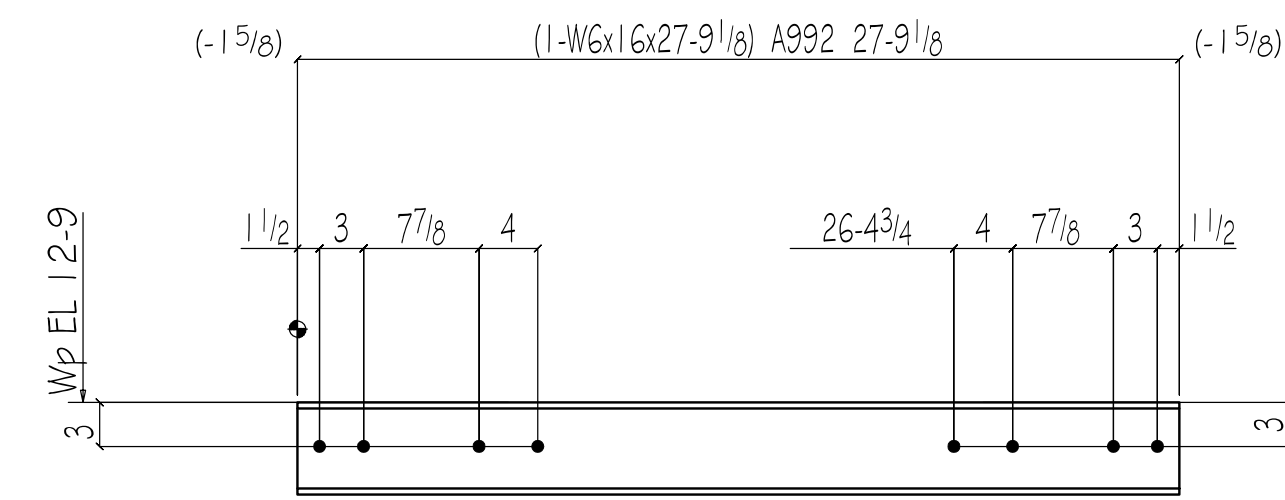

ONE BEAM 19B2

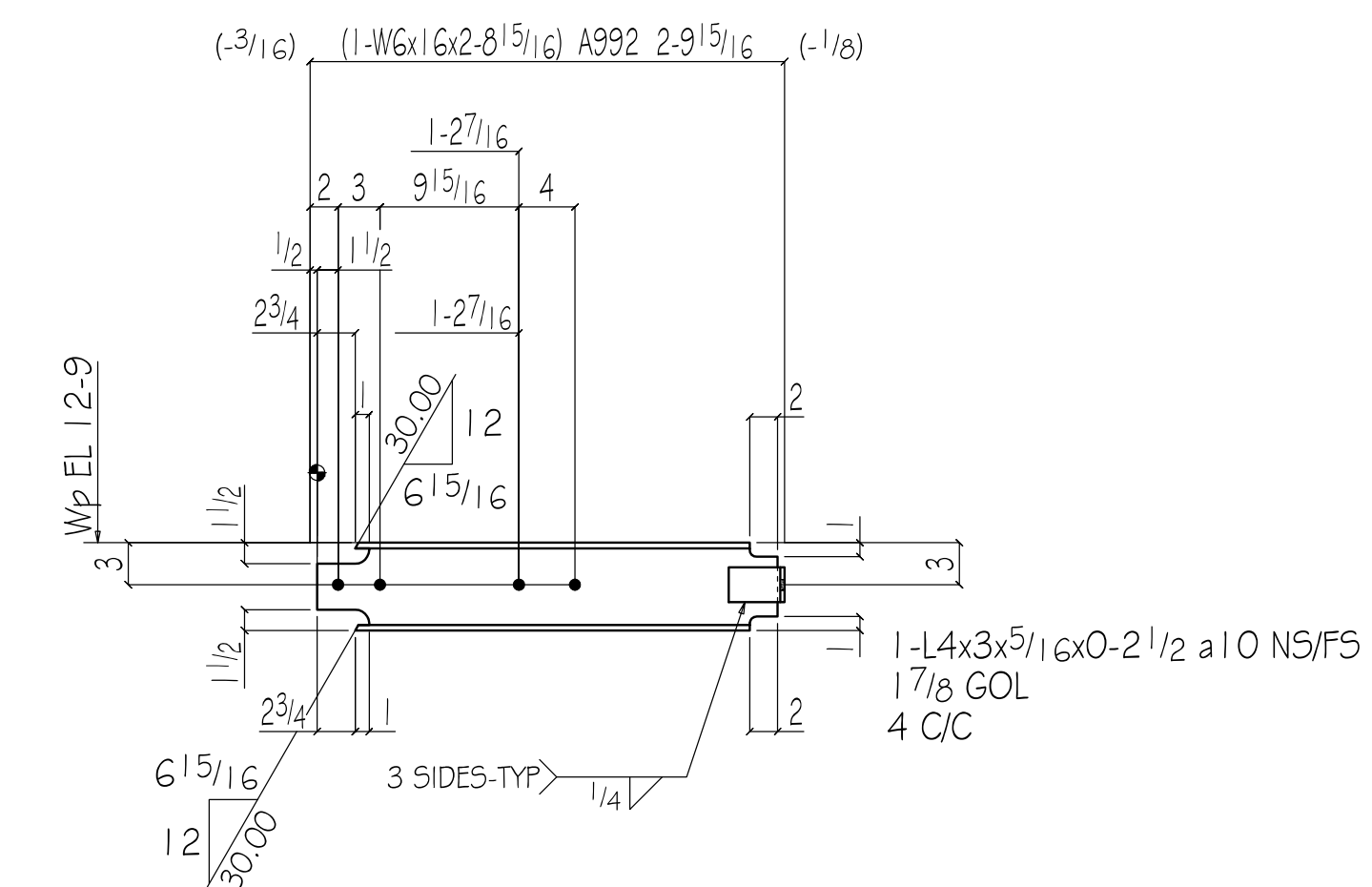

2 BEAMS 19B3

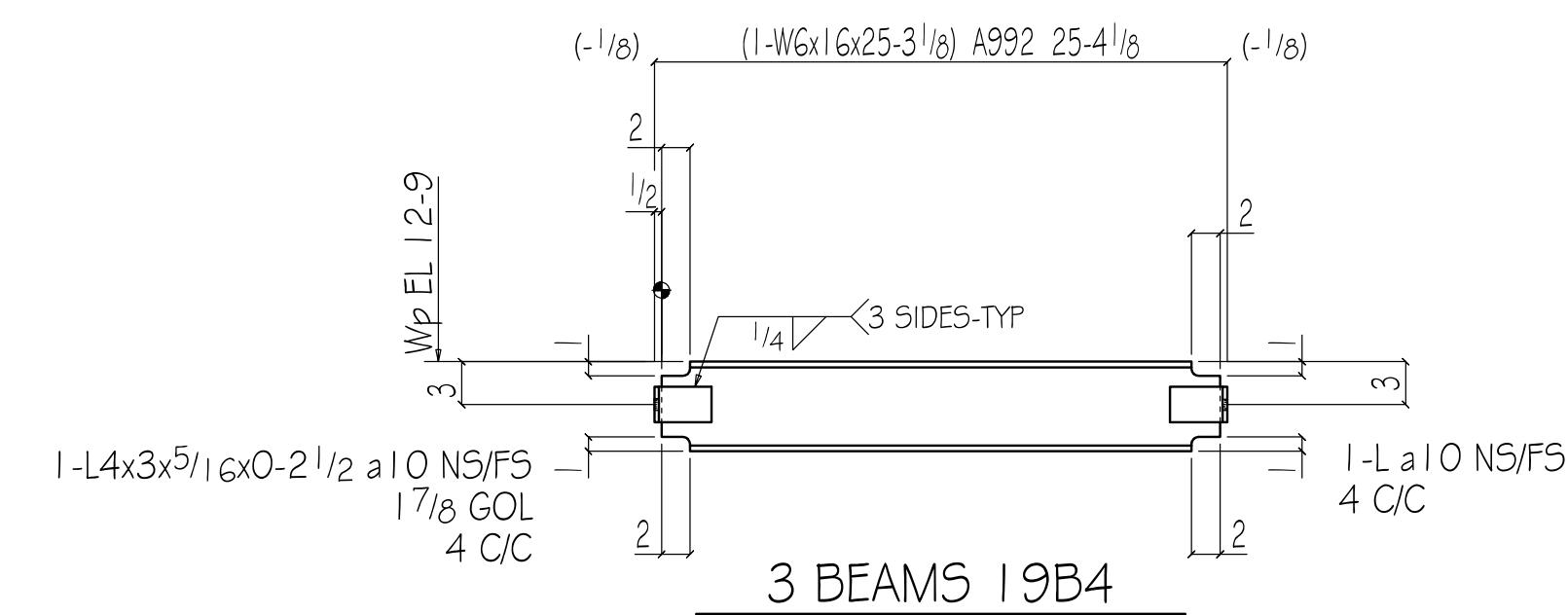

3 BEAMS 19B4

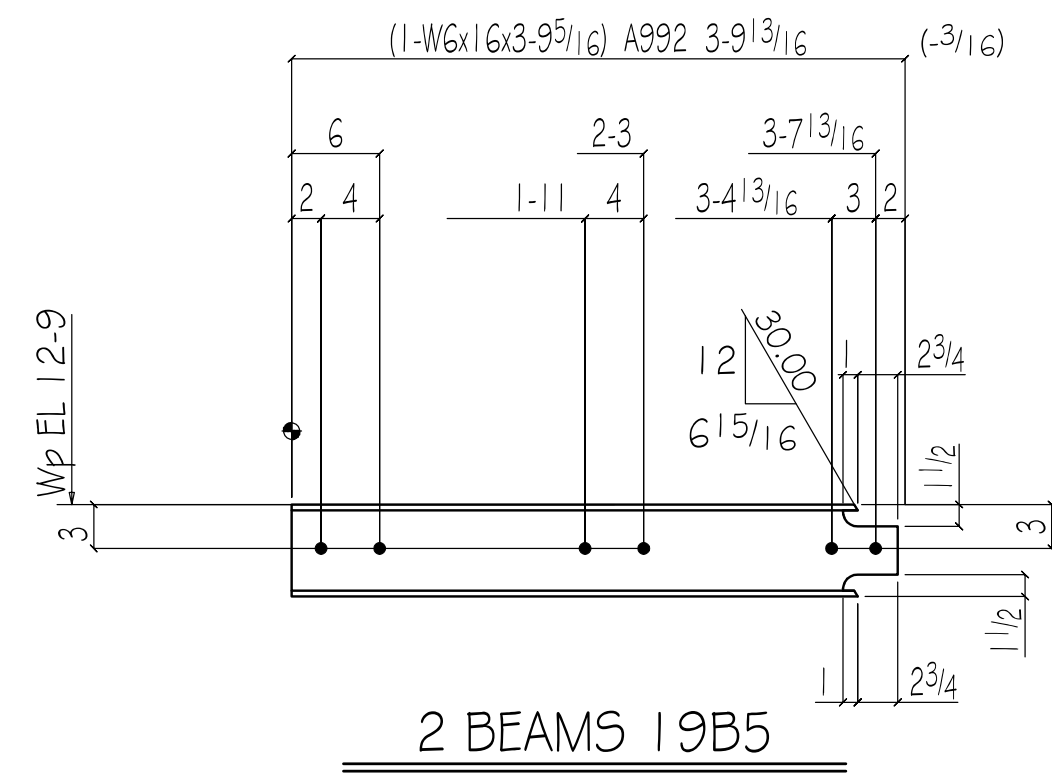

2 BEAMS 19B5

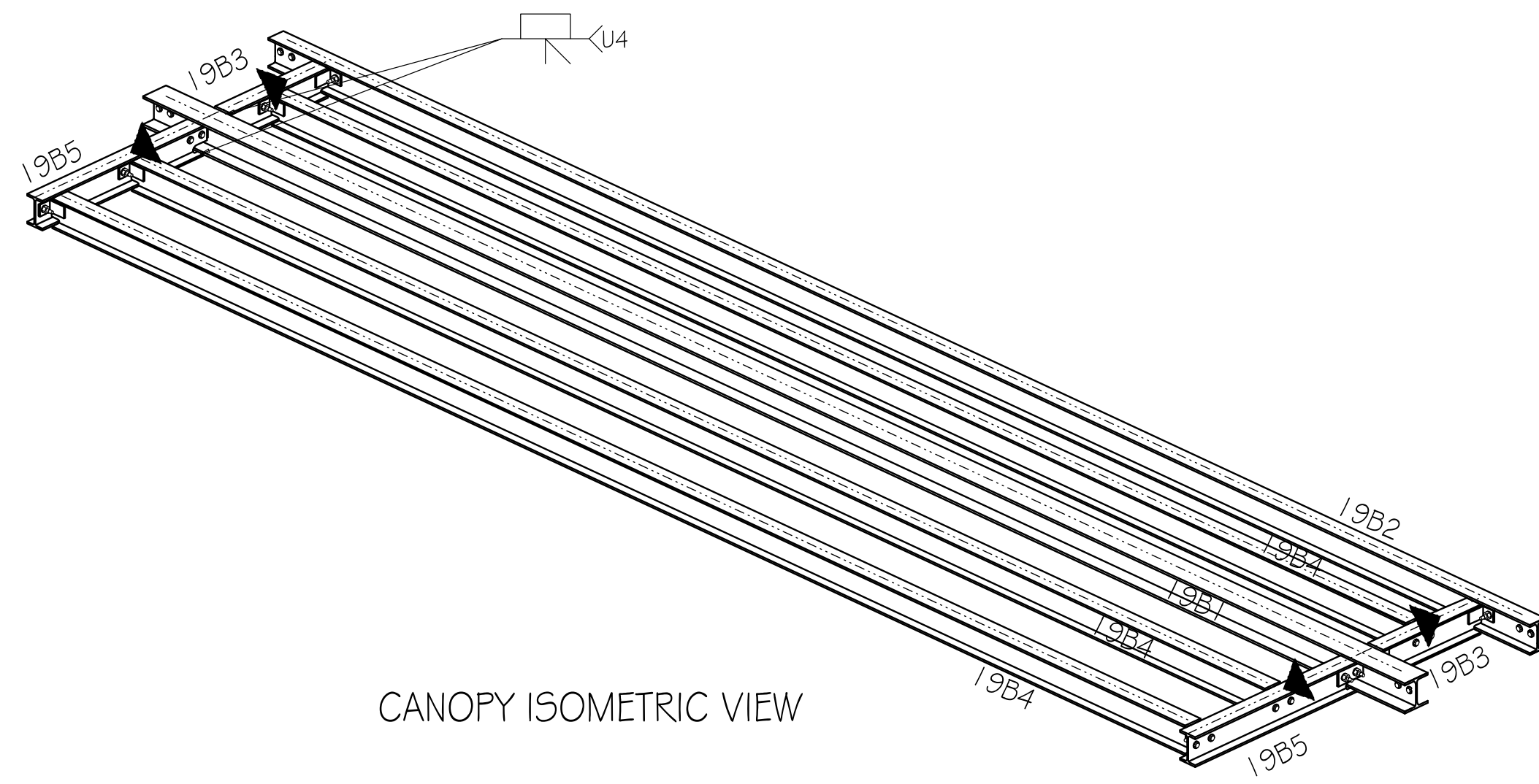

CANOPY ISOMETRIC VIEW

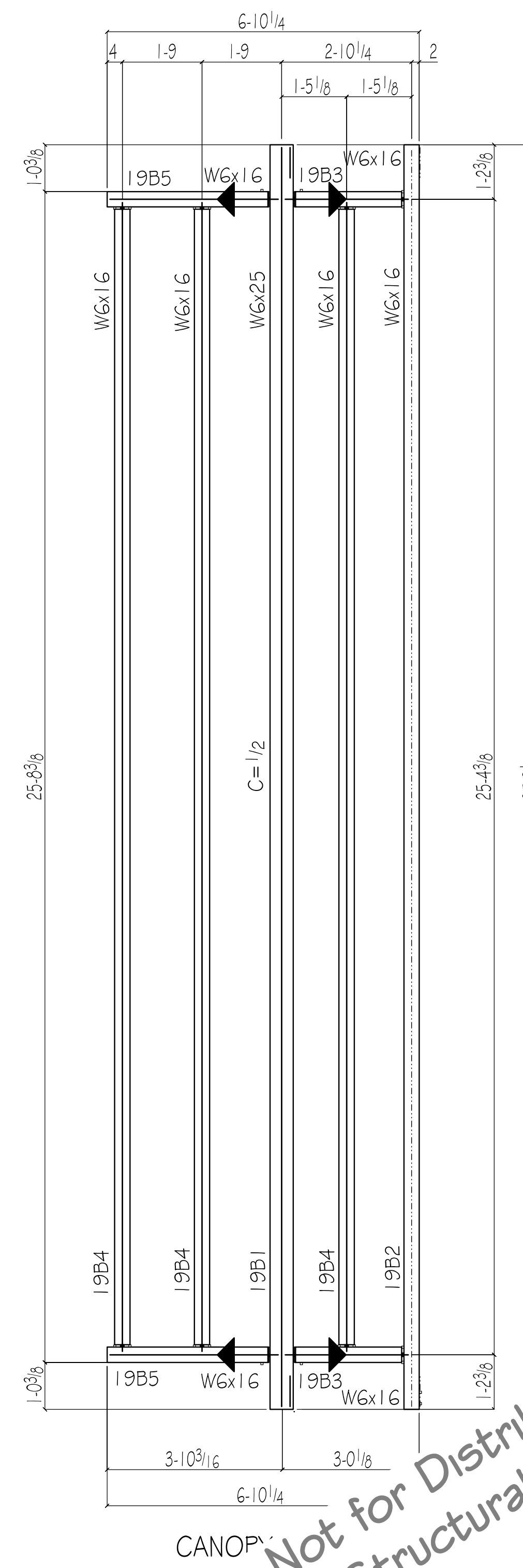

CANOPY

FABRICATOR OPTION #1 - CANOPY ASSEMBLY 10

- NOTES:
1. TRIANGLES DENOTE FULL MOMENT WELDS.
  2. SHOP ASSEMBLY PC. MARK: 19F1.
  3. 19B1 IS CAMBERED, FABRICATE WITH CAMBER.
  4. SHOP WELD TEMP. ALIGNMENT ANGLE FOR SHIPPING AND ERECTION.
  5. REMOVE TEMP. ANGLES AFTER ERECTION.

BILL OF MATERIAL

| QTY. Total | Piece Mark | Material Description | Length Feet Inches | Steel Grade | Remarks |
|------------|------------|----------------------|--------------------|-------------|---------|
| ONE        | 19B1       | BEAM                 |                    |             |         |
| 1          | 19B1       | W6x25                | 27 9 1/8           | A992        | C=1/2   |
| 4          | p145       | PL 3/8x3             | 0 6 1/2            | A36         |         |
| ONE        | 19B2       | BEAM                 |                    |             |         |
| 1          | 19B2       | W6x16                | 27 9 1/8           | A992        |         |
| 2          | 19B3       | BEAM                 |                    |             |         |
| 2          | 19B3       | W6x16                | 2 8 15/16          | A992        |         |
| 4          | a10        | L4x3x5/16            | 0 2 1/2            | A36         |         |
| 3          | 19B4       | BEAM                 |                    |             |         |
| 3          | 19B4       | W6x16                | 25 3 1/8           | A992        |         |
| 12         | a10        | L4x3x5/16            | 0 2 1/2            | A36         |         |
| 2          | 19B5       | BEAM                 |                    |             |         |
| 2          | 19B5       | W6x16                | 3 9 5/16           | A992        |         |

Copyright © 2021 Mid-Atlantic Structural Detailing, Inc. - All Rights Reserved.

Not for Distribution