

# ChillBox™ CWHP-18/24/30 HeatPak



*In Keeping With Its Policy Of Continuous Progress And Improvements, JRJ Manufacturing Reserves The Right To Make Changes Without Notice And Incurring Obligation.*

## ChillBox™ CW-HP HeatPak Series are built with the following features:

- Advanced Coil Design
- Non-Corrosive Hardware
- Air Purge Valve
- 2 lb. Thermal Acoustic, Anti-Microbial Duct Insulation
- Built In Flange For Duct Connection

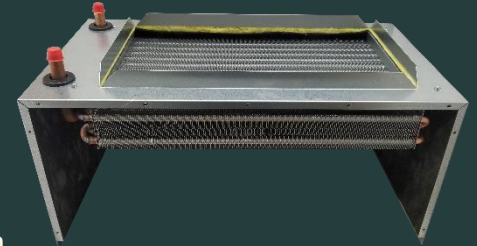

*(Not to used with CW-02 Series or CW-50 Series)*

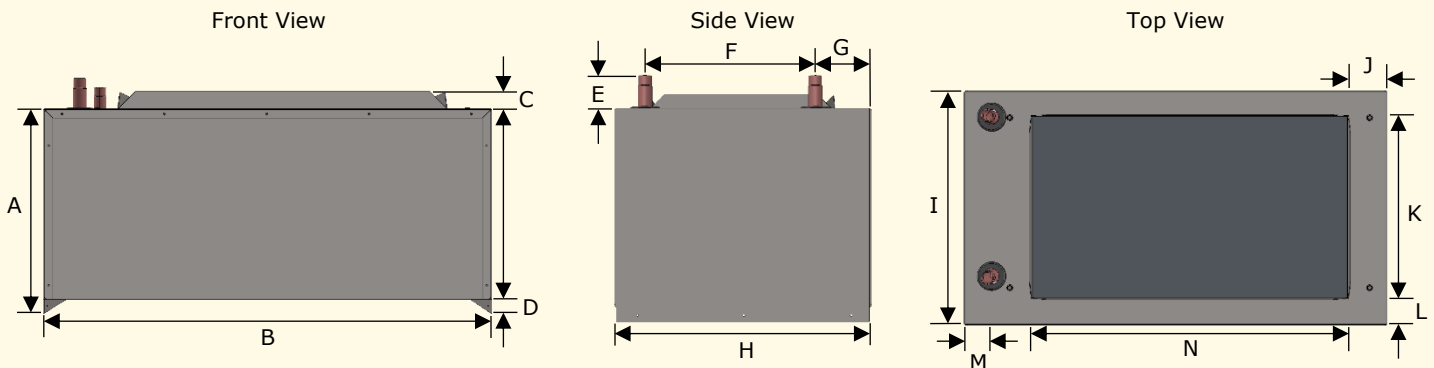

CWHP-1824-00					
A	11"	J	2-1/4"	S	--
B	24"	K	10-1/4"	T	--
C	1"	L	1/2"	U	--
D	3/4"	M	1-1/2"	V	--
E	1-1/2"	N	18"	W	--
F	10"	O	--	X	--
G	1-1/4"	P	--	Y	--
H	13"	Q	--	Z	--
I	13-1/4"	R	--		

CWHP-3000-00					
A	11"	J	2-1/4"	S	--
B	29"	K	10-1/4"	T	--
C	1"	L	1-1/2"	U	--
D	3/4"	M	6-1/4"	V	--
E	1-1/2"	N	18"	W	--
F	10"	O	--	X	--
G	2-1/2"	P	--	Y	--
H	13"	Q	--	Z	--
I	13-1/4"	R	--		

	Heat Capacity (BTHU)						
	Dry Bulb 60° F / Wet Bulb 50° F , 50% RH Entering Air Conditions						
	GPM	600 CFM	700 CFM	800 CFM	900 CFM	1,000 CFM	Coil P.D. (Ft.WTR.)
120°F Entering Water	2	18,800	20,000	21,000	21,900	23,300	0.9
	3	20,900	22,400	23,700	24,800	26,700	2
	4	22,000	23,800	25,300	26,600	28,800	3.4
	5	22,800	24,700	26,300	27,800	30,200	5.1
140°F Entering Water	2	25,300	26,900	28,300	29,500	31,500	0.9
	3	28,000	30,100	31,900	33,400	36,000	1.9
	4	29,600	31,900	34,000	35,800	38,800	3.3
	5	30,600	33,100	35,300	37,300	40,700	5
160°F Entering Water	2	31,900	34,000	35,700	37,800	39,800	0.9
	3	35,300	37,900	40,100	42,100	45,400	1.9
	4	37,200	40,200	42,700	45,000	48,900	3.2
	5	38,500	41,700	44,400	46,900	51,200	4.8
180°F Entering Water	2	38,600	41,100	43,200	45,100	48,100	0.9
	3	42,600	45,800	48,500	50,900	54,900	1.8
	4	44,900	48,500	51,600	54,300	59,000	3.1
	5	46,400	50,200	53,600	56,600	61,800	4.7

JRJ Manufacturing, LLC

24910 Reservoir Road, Cascade, MD 21719 / Phone: 717-941-1180 / Fax: 717-941-1181