

# KEYSTONE CONSTRUCTION MANUAL





# TOC

---

<b>Definitions .....</b>	<b>2</b>
<b>Introduction .....</b>	<b>5</b>
Keystone Standard <sup>®</sup> Unit Series .....	8
Keystone Compac <sup>®</sup> Unit Series .....	9
<b>Basic Installation .....</b>	<b>11</b>
Wall Sections .....	20
<b>Design Charts .....</b>	<b>23</b>
Gravity Charts .....	25
Reinforced Charts .....	29
<b>Corners &amp; Curves .....</b>	<b>37</b>
90° Outside Corner .....	38
90° Inside Corner .....	44
Acute Corner .....	46
Concave Curves .....	49
Convex Curves .....	51
<b>Wall Finishing .....</b>	<b>55</b>
Caps .....	56
CIP Concrete Coping .....	59
<b>Specialty Construction Details .....</b>	<b>61</b>
Retaining Wall Drainage .....	62
Water Applications .....	64
Headwall Applications .....	66
Barriers .....	68
Step and Stair .....	78
Terraced Wall Application .....	82
Wall Repair .....	84
Planting Guidelines .....	85
Creative Options .....	86

## Definitions

**AASHTO** – American Association of State Highway and Transportation Officials

**ASTM** – American Society for Testing and Materials

**Backfill** – Soil used to replace a zone of excavated soil.

**Backslope** – The angle of the slope or finished grade located behind the top of the wall, usually expressed in a ratio such as 3:1 (3 feet [0.9m] horizontal to 1 foot [305mm] vertical) or in degrees, 18.4° or in percent, 33%.

**Base Course** – First row of Keystone units placed on top of the leveling pad.

**CIP** – Cast In Place concrete.

**Compaction** – Mechanical effort used in densifying soil to a defined minimum percentage of the maximum compacted weight of the soil. See ASTM D698 and D1557 for reference.

**Core Fill** – See Unit Drainage Fill.

**Course** – A horizontal layer or row of Keystone units.

**DOT** – Department of Transportation

**Drainage Composite** – Three dimensional geosynthetic drainage medium encapsulated in a geotextile filter, used to transport water.

**Drainage Pipe** – A perforated or slotted PVC pipe manufactured in accordance with ASTM D3034, or corrugated HDPE pipe manufactured in accordance with AASHTO M 252, used to transport water away from the drainage zone or reinforced backfill.

**Drainage Zone** – A predetermined depth of clean crushed angular stone located behind a Keystone unit to prevent the development of hydrostatic forces on the Keystone wall facing. Also see Unit Drainage Fill.

**Efflorescence** – A whitish substance that can naturally occur on all concrete products. Efflorescence occurs when salts from within the concrete unit are transported to the exterior surface by water or from external chlorides.

**Embedment** – Depth of retaining wall below existing or proposed ground line.

**Exposed Wall Face** – The exposed visible portion of the retaining wall when installed.

**Extensible Reinforcement** – See Geogrid.

**Foundation Soil** – Either in-situ soil or compacted backfill, located beneath wall leveling pad and reinforced fill volume.

**Geogrid** – A synthetic extensible structural soil reinforcement element formed by a regular network of integrally connected tensile elements with apertures of sufficient size to allow interlocking with surrounding soil, rock, or earth; functions primarily as reinforcement and is typically a HDPE or Polyester material.

**Geosynthetics** – A range of generally polymeric (plastic) products used to solve civil engineering problems. Generally regarded to encompass eight main categories: geotextiles, geogrids, geonets, geomembranes, geosynthetic clay liners, geofam, geocells and geocomposites.

**Geotextile Filter Fabric** – Material used for separation and filtration of dissimilar soil types; typically consists in two forms, woven or nonwoven synthetic fibers (polymer based).

**Global Stability** – The general mass movement analysis of a soil reinforced retaining wall structure(s) and adjacent soil masses and slopes.

**HDPE** – High-Density Polyethylene; a polyethylene thermoplastic made from petroleum.

**IBC** – International Building Code

**Impermeable or Low Permeable Soil** – Soil with clay content used to prevent water percolation into the drainage zone and reinforced backfill behind the retaining wall.

**Inextensible Reinforcement** – Galvanized steel soil reinforcement.

**Keystone unit** – A concrete retaining wall element, machine made from Portland cement, water, and aggregates by a licensed Keystone manufacturer.

**Leveling Pad** – Material used to support the Keystone unit, typically compacted crushed stone material or unreinforced CIP concrete.

**Modular Block** – See Keystone unit.

**MSE** – Mechanically Stabilized Earth

**NCMA** – National Concrete Masonry Association

**Parapet** – Keystone units or CIP concrete installed above finished grade to create a freestanding wall that does not retain soil.

**Polyester** – A polymer fiber used in the production of geogrids.

**PPE** – Personal Protective Equipment, i.e.: hard hat, gloves, eye protection, etc.

**PVC** – Polyvinyl Chloride; a thermoplastic polymer.

**Reinforced Soil (Reinforced Backfill)** – Compacted soil that is placed within the reinforced soil volume as outlined on the plans.

**Reinforcement** – See Geogrid.

**Retained Soil** – In-situ soil or compacted backfill located directly behind the reinforced soil volume or gravity wall system.

**Segmental Wall Unit** – See Keystone unit.

**SRW** – Segmental Retaining Wall; i.e., multiple Keystone units installed to create a retaining wall.

**Surcharge** – Any loading imposed on the soil behind the wall that exerts an additional force on a wall structure. Surcharge loadings are assumed to be uniform live or dead loads. Usually expressed in pounds per square foot (psf) or kilo-newton per square meter (kN/m<sup>2</sup>).

**Surcharge-slope** – Any additional loading imposed on the wall structure due to backslope conditions behind the wall.

**Swale** – A ditch or depression in the soil at the top or bottom of the retaining wall used to divert water to another location away from the wall.

**Toe Slope** – The slope angle of the soil located in front of the wall base, usually expressed in a ratio such 3:1 (3 feet [0.9m] horizontal and 1 foot [305mm] vertical) or in degrees, 18.4° or in percent, 33%.

**Unit Drainage Fill** – Crushed stone that is placed within and immediately behind the Keystone concrete units, measuring 2 feet (610mm) in total depth from the proposed wall face. Also see drainage zone.

**Wall Batter** – The setback angle measured in degrees created from the fiberglass pin placement location within the Keystone units. The angle is measured using a plumb line from the toe to the top of the wall along the face of the wall.



KEYSTONE COMPAC®

The Keystone retaining wall system was created to provide an economical, easy-to-install, aesthetically appealing, and structurally sound system as an alternative to boulder, timber tie, concrete panel, or cast-in-place retaining walls. The Keystone system was initially conceived as a gravity wall system that could be constructed to heights of up to 6.5 feet (2m). The original Keystone Standard unit was 2 feet (610mm) from face to tail, providing weight and stability to resist the applied earth pressures. Later, the Keystone Compac unit, a smaller 1 foot (305mm) deep unit, was introduced. Both of these Keystone units have the stability of a large mass, but are easier to handle, lighter to place, and quicker to install than boulders, crib structures or thin-shelled panel structures. Both units were designed with a structural pin connection and granular interlock, eliminating the need for grouting or mortar. As a result of the structural strength created by the fiberglass pins and unit drainage fill, the interlocked assembly is more stable than most other structures.

Concurrent with the development of the Keystone system, geosynthetic soil reinforcement was gaining approval and acceptance as a viable soil reinforcement material. With the structural pin and crushed stone fill for interlock, the combination of geogrids and Keystone units provides an integrated wall system that can be constructed to heights far exceeding the limits of simple gravity walls. Since 1986, millions of square feet of Keystone retaining walls have been successfully constructed, both as gravity and reinforced systems. Applications vary from residential landscaping walls to structural highway walls, some exceeding 50 feet (15.2m) in height.

---

## KEYSTONE RETAINING WALL UNITS

Keystone retaining wall units are a zero-slump concrete masonry product developed specifically for use in earth retaining wall structures. Keystone has developed a wide variety of shapes and designs to accommodate most architectural and structural requirements. Local producers of the Keystone products have a variety of colors available, complementing most landscaping and structural retaining wall applications.

Keystone structural products currently discussed in this manual include:

- Keystone Standard® I/ Keystone Standard® II/ Keystone Standard® III
- Keystone Compac® II/ Keystone Compac® III

Other Keystone structural products that utilize Keystone's fiberglass pin system (please contact your local Keystone representative for availability):

- Keystone Century Wall®
- Country Manor®
- Stonegate® Country Manor®

The Keystone units listed above are designed for use as structural retaining walls, i.e., those exceeding 4 feet (1.2m) in height and/or supporting structures or highway loading.

In addition to the above units, Keystone has a complete line of landscape products that are marketed and sold through retail distribution and landscape supply outlets. The concepts in this manual apply to all wall construction, but these landscape products are generally not considered for structural applications and are not discussed in further detail in this manual. For more information on these products, contact your local Keystone representative or visit [www.keystonewalls.com](http://www.keystonewalls.com).

## Introduction

### KEYSTONE MATERIALS

Keystone units are typically manufactured of concrete with a minimum compressive strength of 3,000 psi (21MPa) at 28 days and a maximum absorption of 8%. All dimensions are plus or minus 1/8 inch (3mm), per ASTM C1372, except for the unit depth, which varies due to the split rock finish. The manufacturing process is automated, so the mixing, compaction, and curing are performed under controlled conditions and provide consistent quality. The units have various face textures available, depending on your local manufacturer. Some of our most popular textures are split-rock finish in various natural colors. Face shapes can be tri-plane, straight, Victorian or Regency. Face texture can be added by incorporating any of Keystone's manufacturing technologies: KeyKut®, JAWS Technology® and Sculpterra® (which creates a molded face such as Hewnstone).

Keystone Standard and Keystone Compac are vertically interconnected using high-strength pultruded fiberglass pins. The Keystone units have cores that are filled with clean crushed stone to provide additional mechanical interlock and internal drainage. The pins assure a running bond configuration of the units and provide significant lateral connection strength between units. The pins improve the connection between the units and the structural soil reinforcement while assuring proper placement of the reinforcement materials.

The connection pins are available in straight and shouldered designs. Straight pins are 5 1/4 inches (133mm) long and 1/2 inch (13mm) in diameter. The Keystone Standard and Keystone Compac units use straight pins. Shouldered pins are 3 3/4 inches (95mm) long and 1/2 inch (13mm) in diameter. The shouldered length portion is 7/8 inch (22mm) and the shouldered diameter is 3/4 inch (19mm). The Keystone Century Wall, Country Manor and Stonegate Country Manor units use shouldered pins. The minimum pin strength is 6,400 psi (44MPa) short beam shear strength and 110,000 psi (750MPa) tensile strength. The pins are manufactured of pultruded fiberglass and will not corrode or deteriorate. In addition, the fiberglass pin does not change properties (soften or become brittle) due to the temperature changes typical in retaining wall applications.

### KEYSTONE STANDARD® UNIT SERIES

The Keystone Standard unit varies due to manufacturing considerations from 18-21 inches (457-533mm) in depth, with a typical face width of 18 inches (457mm) and height of 8 inches (203mm). The geometry yields exactly 1 square foot (0.093 m<sup>2</sup>) of face area per unit. Units weigh from 82-114 pounds (37-52kg) each, varying with local manufacturing and aggregates. The centroid of the unit is slightly forward of center toward the face, but for design purposes, it is taken at the center. For design purposes, the in-place density of the aggregate filled unit is 120 pcf (18.85 kN/m<sup>3</sup>).



Keystone Standard units are manufactured with a dual pin hole configuration. The front pin setting allows the units to be placed at a minimum setback of approximately 1/8 inch (3mm) per 8 inch (203mm) unit height (1° batter, for design purposes use 0°). The rear pin setting allows placement of the units at a minimum 1 inch (25mm) setback per 8 inch (203mm) unit height (8° batter). An alternate placement of front/back pin hole allows a setback of 5/8 inch (16mm) per 8 inch (203mm) unit height (4° batter).

### KEYSTONE COMPAC® UNIT SERIES

The Keystone Compac unit is a 12 inch (305mm) deep unit with a typical face width of 18 inches (457mm) by 8 inches (203mm) high. This geometry yields exactly 1 square foot (0.093 m<sup>2</sup>) of face area per unit. Depth may vary from 11.5-12.5 inches (292-318mm) depending upon local manufacturing and splitting requirements. Units weigh from 67-89 pounds (30-40kg) each, varying with local manufacturing and aggregates. For design purposes, the in-place density of the aggregate filled unit is 120 pcf (18.85 kN/m<sup>3</sup>).



The dual pin hole configuration allows the same 1° (0° for design purposes), 4°, and 8° setback as the Keystone Standard unit.



## KEYSTONE CENTURY WALL® UNITS

Keystone Century Wall is a three piece system that consists of a small, medium, and large unit. The width of the units is the varying dimension that dictates the size. The small unit is 7 inches (178mm) wide, the medium unit is 11 inches (279mm) wide, and the large unit is 18 inches (457mm) wide. The three Century Wall units are 12 inches (305mm) deep and 8 inches (203mm) high. The small unit weighs 41-45 pounds (19-20kg), the medium unit weighs 54-58 pounds (24-26kg), and the large unit weighs 82-87 pounds (37-39kg). Weights may vary with local manufacturing and aggregates. The 4" (102mm) high Half-Century Wall system is available in select markets. Contact your local Keystone representative for product availability.



Keystone Century Wall Units

Similar to the Keystone Compac and Standard units, a dual pin hole configuration allows 1° (0° for design purposes), 4°, and 8° setback.

## COUNTRY MANOR®

Country Manor comes in a variety of sizes and is most commonly sold as a five piece system, a three piece system, or a two piece system. The units are textured on three sides, allowing for both 1 and 2-sided applications to be built. The width of the units are the varying dimension that dictates the size: each unit has 2 unit width dimensions, because both sides of the unit can be incorporated in the wall face. The various unit widths are 6/4 inches (152/102mm), 10/8 inches (254/203mm), 12/12 inches (305/305mm), 12/10 inches (305/254mm), and 16/14 inches (406/356mm). The Country Manor units are 10 inches (254mm) deep and 6 inches (152mm) high. The unit weights are as follows: 6/4 unit is 21-24 pounds (10-11kg), 10/8 unit is 30-42 pounds (14-19kg), 12/12 unit is 51-55 pounds (23-25kg), 12/10 unit is 47-51 pounds (20-23kg), 16/14 unit is 60-65 pounds (27-29kg). Weights may vary with local manufacturing and aggregates.



Keystone Country Manor Units

## STONEGATE® COUNTRY MANOR®

Stonegate Country Manor is available in a three piece system in both 6" (152mm) and 3" (76mm) high units. These units have a smooth weathered stone texture on three sides, allowing for both 1 and 2-sided applications to be built. The various unit widths are 6/4 inches (152/102mm), 12/10 inches (305/254mm), and 16/14 inches (406/356mm). The Stonegate Country Manor units are 10 inches (254mm) deep and either 6 inches (152mm) or 3" (76mm) high. The 6" (152mm) unit weights are as follows: 6/4 unit is 21-24 pounds (10-11kg), 12/10 unit is 47-51 pounds (20-23kg), 16/14 unit is 60-65 pounds (27-29kg). The 3" (76mm) unit weights are as follows: 6/4 unit is 9-11 pounds (4-5kg), 12/10 unit is 22-24 pounds (10-11kg), 16/14 unit is 30-33 pounds (14-15kg). Weights may vary with local manufacturing and aggregates.



Stonegate Country Manor Units

Unique to Country Manor and Stonegate Country Manor: the three pin hole configurations allow for a vertical wall, 1 inch (25mm) setback, or allow random units to protrude from the wall face at a 1 inch (25mm) increment. (The design batter is 0° or 9.5° for the setback alignment.)

**Note:**

Not all units types, face treatments and colors are available at all manufacturing locations. Please check with your local manufacturer or Keystone supplier for availability.

The information contained herein has been compiled by Keystone Retaining Wall Systems® LLC and to the best of our knowledge, accurately represents the Keystone product use in the applications which are illustrated. Final determination of the suitability for the use contemplated and its manner of use are the sole responsibility of the user. Structural design and analysis shall be performed by a qualified engineer.

# Keystone Standard® Unit Series



## THE KEYSTONE STANDARD UNIT IS AN AMERICAN ORIGINAL.

The product that started the industry is still the industry leader for tall walls and critical structures. The height-to-depth ratio of the Keystone Standard unit delivers a structurally sound, engineered wall system with superior construction stability, durability, and strength. Architects, engineers, and contractors rely on the Keystone Standard unit to stand strong when the safety and security of their wall designs matter.

	Standard I		Standard II	Standard III	
Unit Height	8" (203mm)		8" (203mm)	8" (203mm)	
Unit Width	18" (457mm)		18" (457mm)	18" (457mm)	
Unit Depth	18" (457mm)	21" (533mm)	18" (457mm)	18" (457mm)	21" (533mm)
Face Area per Unit	1SF (0.093m <sup>3</sup> )		1SF (0.093m <sup>3</sup> )	1SF (0.093m <sup>3</sup> )	
Unit Weight	95-125lbs (43-57kg)		93-115lbs (42-52kg)	90-100 lbs (41-45kg)	
Volume of Voids to Tail	0.70 ft <sup>3</sup> /ft <sup>2</sup> (0.21m <sup>3</sup> /m <sup>2</sup> )	0.90 ft <sup>3</sup> /ft <sup>2</sup> (0.27m <sup>3</sup> /m <sup>2</sup> )	0.70 ft <sup>3</sup> /ft <sup>2</sup> (0.21m <sup>3</sup> /m <sup>2</sup> )	0.81 ft <sup>3</sup> /ft <sup>2</sup> (0.25m <sup>3</sup> /m <sup>2</sup> )	1.01 ft <sup>3</sup> /ft <sup>2</sup> (0.31m <sup>3</sup> /m <sup>2</sup> )
Volume of Voids to 24" depth	1.20 ft <sup>3</sup> /ft <sup>2</sup> (0.37m <sup>3</sup> /m <sup>2</sup> )	1.16 ft <sup>3</sup> /ft <sup>2</sup> (0.35m <sup>3</sup> /m <sup>2</sup> )	1.20 ft <sup>3</sup> /ft <sup>2</sup> (0.37m <sup>3</sup> /m <sup>2</sup> )	1.31 ft <sup>3</sup> /ft <sup>2</sup> (0.40m <sup>3</sup> /m <sup>2</sup> )	1.26 ft <sup>3</sup> /ft <sup>2</sup> (0.38m <sup>3</sup> /m <sup>2</sup> )
Fiberglass Pin	Straight Pin				

Note: Unit weights, dimensions and availability vary by manufacturer. Please contact your local representative.



Standard I  
Tri-plane



Standard I  
Straight



Standard II  
Tri-plane



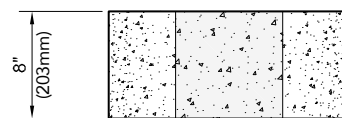
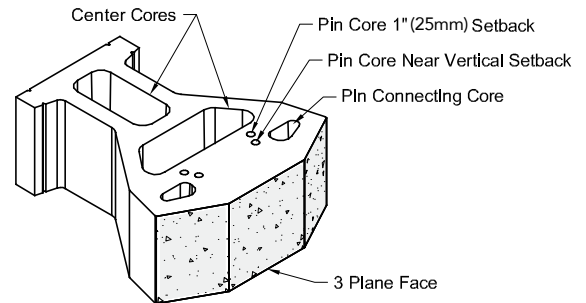
Standard II  
Straight



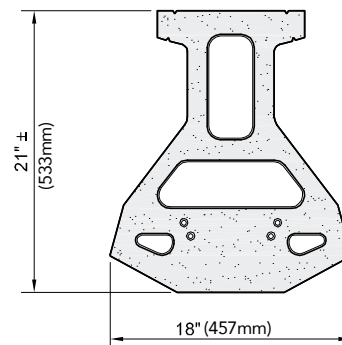
Standard III  
Tri-plane



Standard III  
Straight



3 Plane Standard I Unit Elevation



The information contained herein has been compiled by Keystone Retaining Wall Systems® LLC and to the best of our knowledge, accurately represents the Keystone product use in the applications which are illustrated. Final determination of the suitability for the use contemplated and its manner of use are the sole responsibility of the user. Structural design and analysis shall be performed by a qualified engineer.



**DESIGN AND BUILD WITH CONFIDENCE.** The Keystone Compac is the perfect choice when the deep embedment length of the Keystone Standard unit is not required. An installer's favorite, its lighter weight and shorter tail design make it easy to handle.

	Compac II	Compac III
Unit Height	8" (203mm)	8" (203mm)
Unit Width	18" (457mm)	18" (457mm)
Unit Depth	12" (305mm)	12" (305mm)
Face Area per Unit	1SF (0.093m <sup>3</sup> )	1SF (0.093m <sup>3</sup> )
Unit Weight	78-91lbs (35-41kg)	69-77lbs (31-35kg)
Volume of Voids to Tail	0.35 ft <sup>3</sup> /ft <sup>2</sup> (0.11m <sup>3</sup> /m <sup>2</sup> )	0.41 ft <sup>3</sup> /ft <sup>2</sup> (0.12m <sup>3</sup> /m <sup>2</sup> )
Volume of Voids to 12" depth	1.35 ft <sup>3</sup> /ft <sup>2</sup> (0.41m <sup>3</sup> /m <sup>2</sup> )	1.41 ft <sup>3</sup> /ft <sup>2</sup> (0.43m <sup>3</sup> /m <sup>2</sup> )
Fiberglass Pin	Straight Pin	

Note: Unit weights, dimensions and availability vary by manufacturer. Please contact your local representative.



Compac II  
Tri-plane



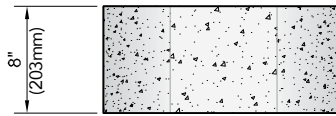
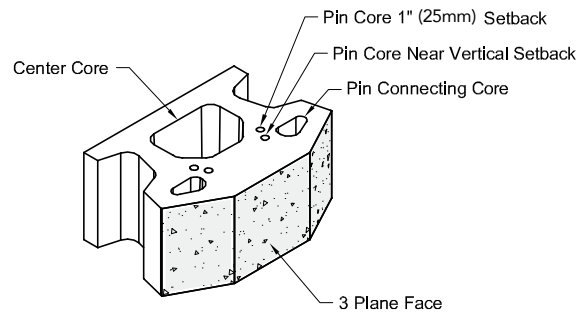
Compac II  
Straight



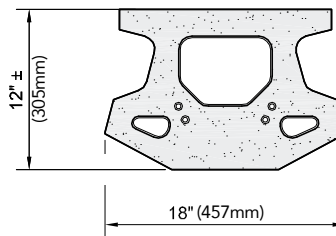
Compac III  
Tri-plane



Compac III  
Straight



3 Plane Compac II Unit Elevation



3 Plane Compac II Unit Plan

### ALTERNATE FACE TEXTURES



Hewnstone



Victorian



Regency



Note:

Product versions vary by manufacturer. Please contact your local representative.

The information contained herein has been compiled by Keystone Retaining Wall Systems® LLC and to the best of our knowledge, accurately represents the Keystone product use in the applications which are illustrated. Final determination of the suitability for the use contemplated and its manner of use are the sole responsibility of the user. Structural design and analysis shall be performed by a qualified engineer.



KEYSTONE COMPAC® VICTORIAN

## SECTION A

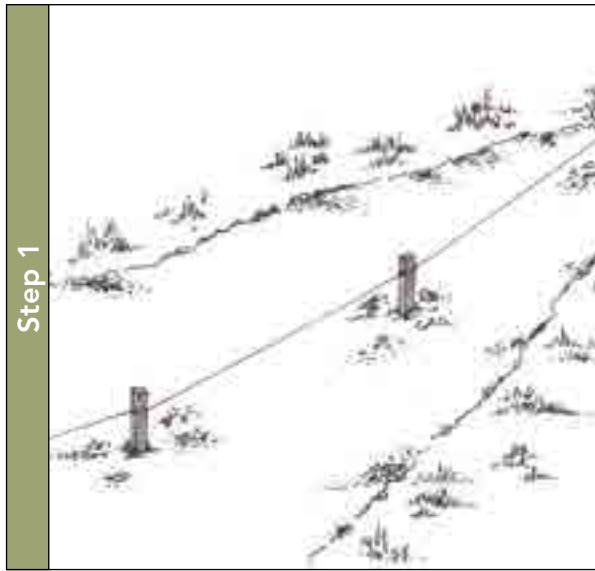
# BASIC INSTALLATION

**Y**ou have chosen your preferred Keystone unit, so now it is time to begin installation of your retaining wall. This section will take you through the step-by-step process of installing your retaining wall. Covered in this section is a basic gravity wall installation and also installation procedures for geogrid reinforced walls. While this section may not cover every construction issue you may encounter on your project, it gives a basic overview and helpful hints for the installation of a Keystone retaining wall.

Tools and materials that will be required:

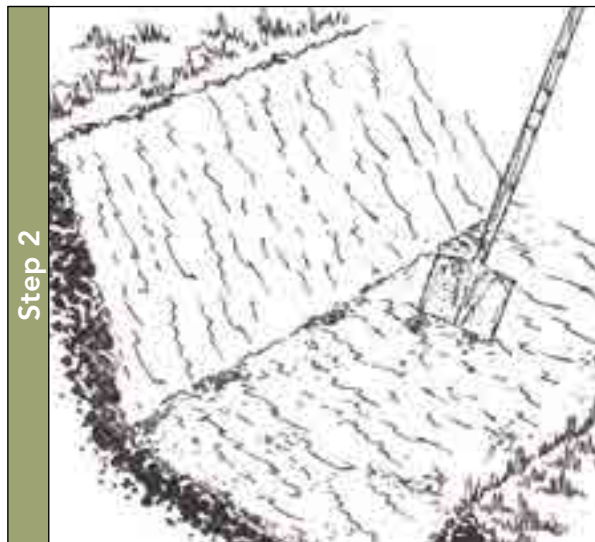
- 12 inch (305mm) and 48 inch (1.2m) levels
- Tape measure
- Shovel
- Excavating equipment
- Personal protective equipment
- 5 lb (2kg) dead blow hammer
- Keystone structural units, caps and fiberglass pins
- Structural geogrid, if required
- Unit drainage fill ( $\frac{3}{4}$  [19mm] inch clean crushed stone)
- Backfill material
- Leveling pad material
- Exterior grade concrete adhesive

# Installation: Step-by-Step



## 1. Site Examination / Permitting

Select the location and length for the retaining wall. Call before you dig! In the United States, calling 811 before every digging job gets your underground utility lines marked for free and helps prevent undesired consequences. Digging without calling can disrupt service to an entire neighborhood, harm you and those around you and potentially result in fines and repair costs. Take the necessary measurements, prepare plans, research zoning requirements for your area and obtain proper building permits for your project. Local permitting may require a soils investigation and/or engineered documentation and drawings.



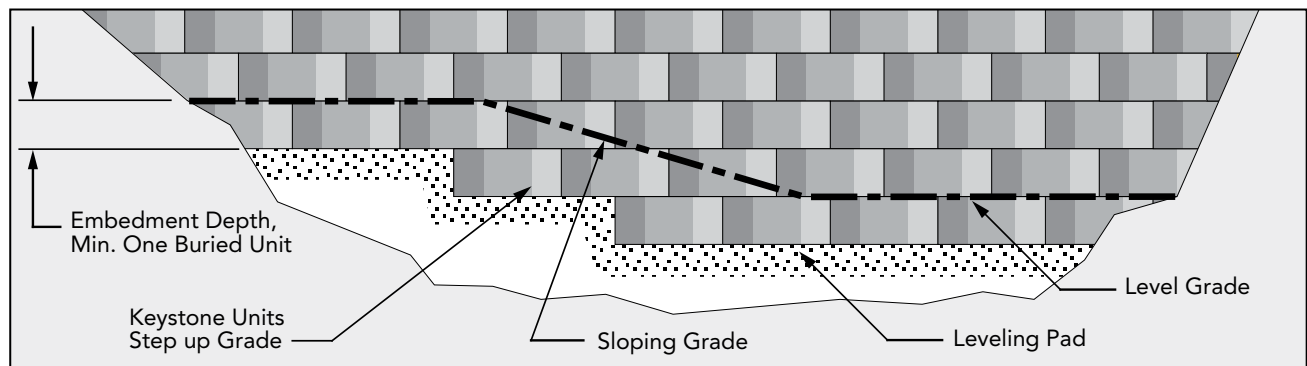
## 2. Excavation / Embedment

Verify that the layout dimensions are correct and excavate to the lines and grades shown on the construction drawings or to field dimensions. Remove all surface vegetation, organic soils and debris; verify that the foundation subgrade is in proper condition prior to leveling pad installation. Do not proceed with installation until unsatisfactory conditions have been corrected.

### Embedment Recommendations

For small Keystone gravity walls, a minimum 1" (25mm) of embedment is recommended for every unit of height (i.e., H/8) or 6" (152mm) minimum, which ever is greater. For reinforced soil Keystone walls, the minimum depth of embedment as a ratio to wall height may be determined in the following table from the NCMA Design Manual for Segmental Walls (2009):

FIGURE A:1



The information contained herein has been compiled by Keystone Retaining Wall Systems® LLC and to the best of our knowledge, accurately represents the Keystone product use in the applications which are illustrated. Final determination of the suitability for the use contemplated and its manner of use are the sole responsibility of the user. Structural design and analysis shall be performed by a qualified engineer.

Slope in Front of Wall	Min. Embedment
Minimum Requirement	0.5 ft (150mm)
Horizontal (walls)	H/20
Horizontal (Abutments)	H/10
3H:1V	H/10
2H:1V	H/7

**Note:**

Project plans, specifications, and design codes may require minimum embedments that exceed the minimums recommended by NCMA.

## Sloping Toe

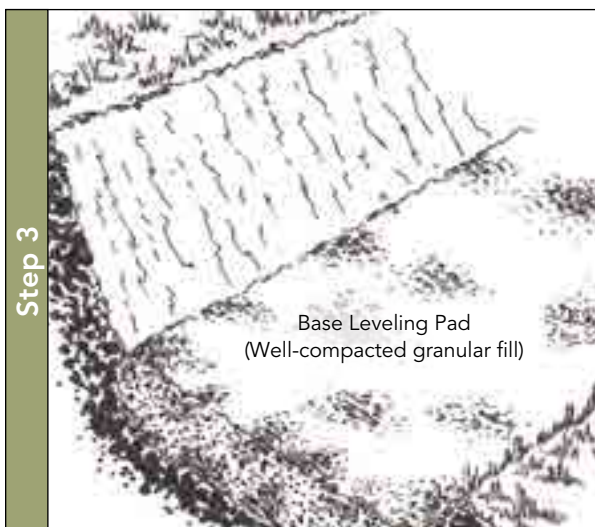
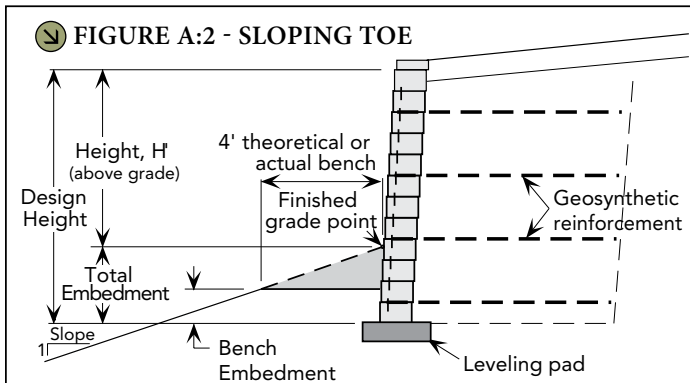
The minimum embedment required with a slope in front of the wall should be based on the establishment of a minimum 4 feet (1.2m) horizontal bench in front of the wall and establishing a minimum embedment from that point. Fill slopes usually have poor compaction near the edge of slope and all slopes are subject to erosion and surficial instability (see figure A:2).

The depth of embedment should be increased when any of the following conditions occur:

- Weak bearing soils
- Potential scour of wall toe
- Submerged wall applications
- Significant shrink/swell/frost properties of foundation soils

**Note:**

The required embedment depth for Keystone walls may become a controversial issue. The International Building Code (IBC) recommends a 1 foot (305mm) minimum or below prevailing frost depth, whichever ever is greater for foundations. AASHTO recommends a 2 foot (610mm) minimum or below prevailing frost depth which ever is greater for retaining structures. These minimum recommended depths are based on rigid foundation systems and are not totally applicable to flexible systems, which function properly with significantly less embedment. The proper embedment depth is a function of the structure size and type, the underlying soils, and the site geometry, especially toe slopes. It is significantly more important to properly inspect the foundation area when excavated, determine the limits of removal and replacement of unsuitable materials, and then confirm the final embedment depth for stability and bearing given the site conditions.

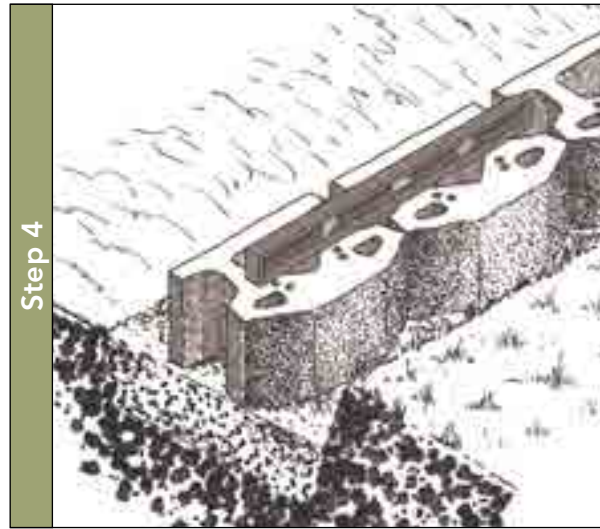


### 3. Prepare the Base Leveling Pad

Start the leveling pad at the lowest elevation along the wall alignment (see Figure A:1). The minimum leveling pad width shall be unit depth + 12 inches (305mm). The leveling pad shall consist of 6 inches (152mm) of well compacted (95% Standard Proctor or greater) angular granular fill (road base or ½ inch to ¾ inch [13-19mm] crushed stone). Concrete is also acceptable to use as a leveling pad. Step the leveling pad up in 8 inch (203mm) increments at the appropriate elevation change in the foundation. Do not use rounded material, i.e. PEA GRAVEL or SAND for leveling pad material.

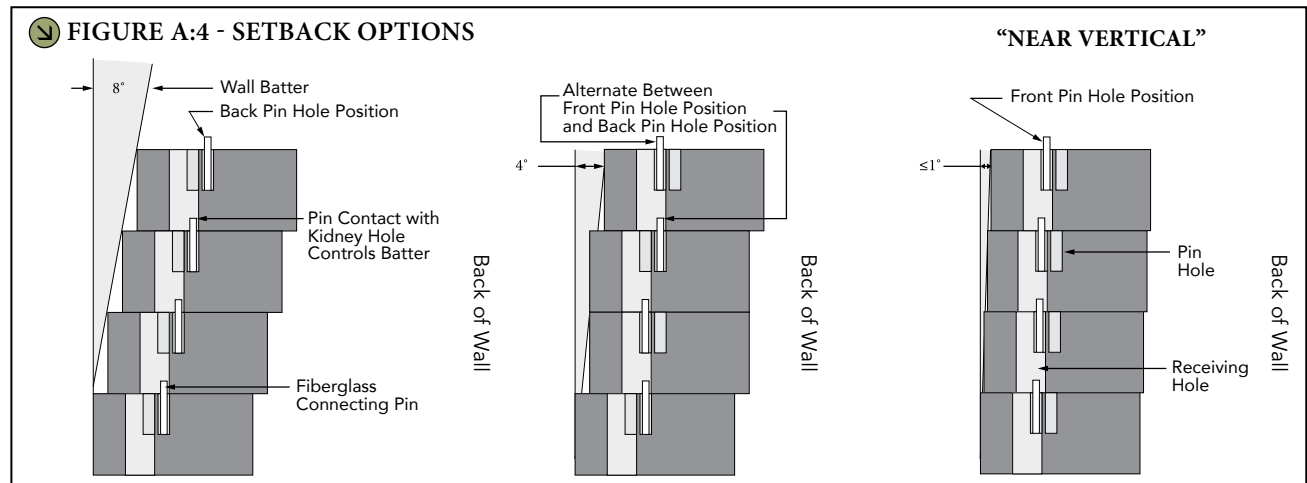
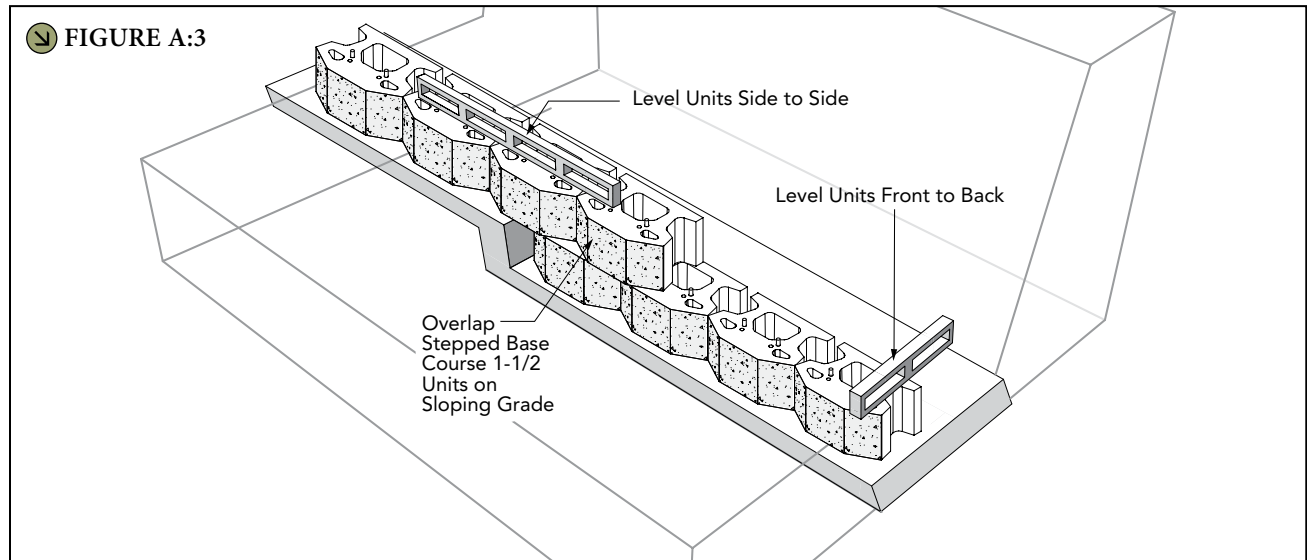
The information contained herein has been compiled by Keystone Retaining Wall Systems® LLC and to the best of our knowledge, accurately represents the Keystone product use in the applications which are illustrated. Final determination of the suitability for the use contemplated and its manner of use are the sole responsibility of the user. Structural design and analysis shall be performed by a qualified engineer.

# Installation: Step-by-Step



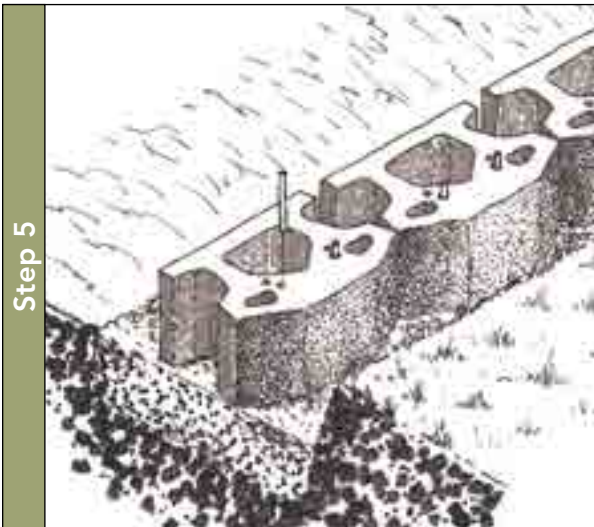
## 4. Install the Base Course

Place the first course of Keystone units (Keystone Compact units shown for illustrative purposes) end to end, with face of wall corners touching (do not leave gaps between units) on the prepared base. The pin holes should face upward, as shown. Ensure that all units are in full contact with the base and properly seated by gently pounding each block corner, and level as required. At base elevation changes (see Figure A:3) for installation reference. Leveling the first course is critical for accurate and acceptable results. Lay out corners and curves in accordance with the “Corners and Curves” section of this manual (p. 37).



The information contained herein has been compiled by Keystone Retaining Wall Systems® LLC and to the best of our knowledge, accurately represents the Keystone product use in the applications which are illustrated. Final determination of the suitability for the use contemplated and its manner of use are the sole responsibility of the user. Structural design and analysis shall be performed by a qualified engineer.



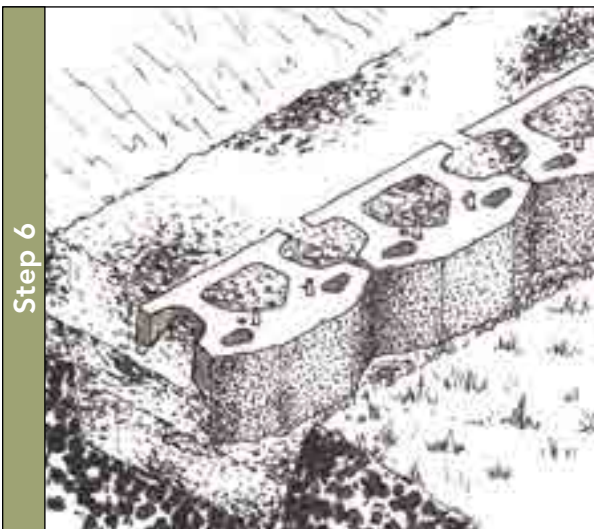


## 5. Insert the Fiberglass Pins/Drainage Pipe

Keystone units have 3 setback options, near vertical, ½ inch (13mm) setback and 1 inch (25mm) setback (see Figure A:4). For the near vertical option, place the pins in the front pin holes, or for the 1 inch (25mm) minimum setback, place the pins in the rear pin holes (see Figure A:5). Once placed, the pins create an automatic setback and alignment for the additional courses (see Figure A:6). When required, install drainage pipe behind wall unit and outlet drain to storm system or daylight. See drainage section for additional details (p. 66).

**Note:**

If drainage is required due to excess water or the design engineer's plans call for a drainage pipe to be installed, add the drain tile behind the tails on the base course. Drainage pipe should maintain positive drainage to daylight, outlet the drainpipe at low points, 50 to 75 feet (15 - 23m) on center and ends of wall.



## 6. Install Unit Drainage Fill/Backfill and Compaction

Once the pins have been installed, provide ½-¾ inch (13-19mm) crushed stone unit drainage material to a minimum total distance of 24 inches (610mm) from wall face. Fill all open spaces between units and open cavities/cores with the same unit drainage material. Place the wall backfill behind the unit drainage fill in maximum 8 inch (203mm) lifts and compact to 95% Standard Proctor Density or 92% Modified Proctor Density with the appropriate compaction equipment. Use only hand-operated equipment within 3 feet (1m) of the retaining wall face.

FIGURE A:5 - PIN INSTALLATION DIAGRAM

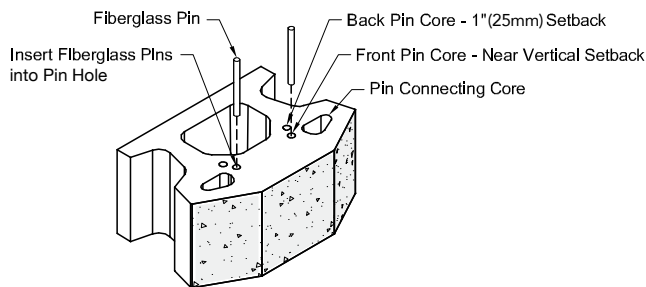
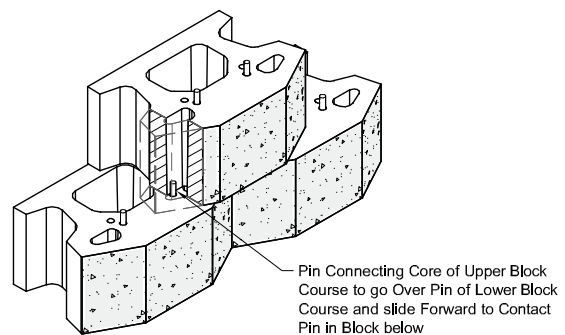
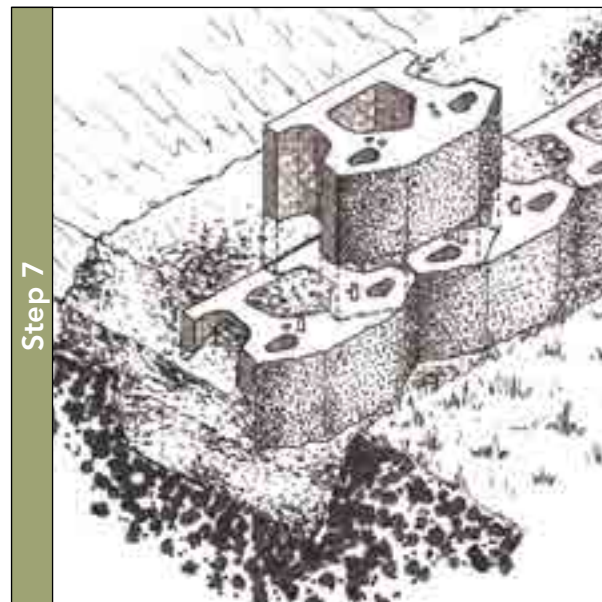


FIGURE A:6 - CONNECTION DIAGRAM



The information contained herein has been compiled by Keystone Retaining Wall Systems® LLC and to the best of our knowledge, accurately represents the Keystone product use in the applications which are illustrated. Final determination of the suitability for the use contemplated and its manner of use are the sole responsibility of the user. Structural design and analysis shall be performed by a qualified engineer.

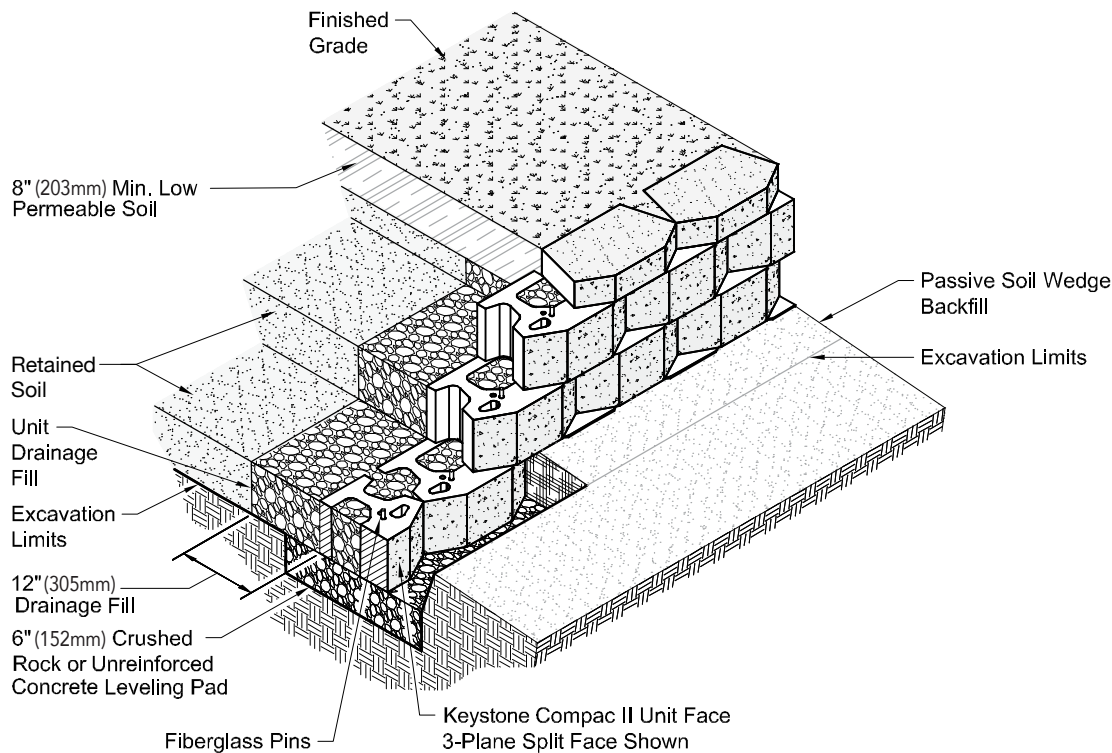
# Installation: Step-by-Step



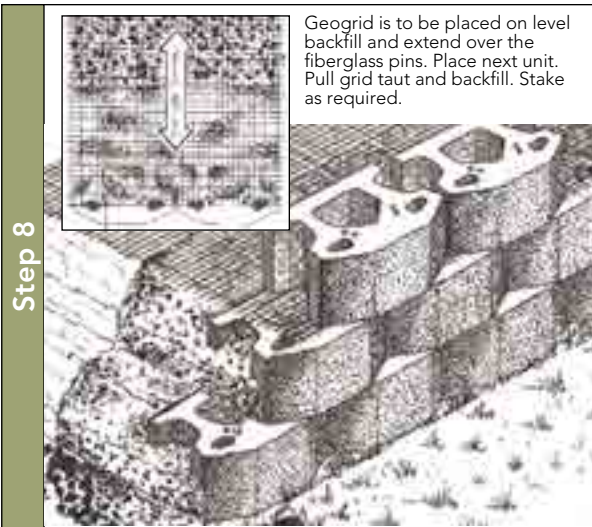
## 7. Install Additional Courses

Remove all excess unit drainage material from the top surface of the all units. Center the next unit in front of the point where the two units below meet, fitting the pins into the pin connecting core of the above unit. Push the units toward the face of the wall until they make full contact with the pins (see Figure A:6). Check level front to back and side to side, shim the units or grind as necessary. It is important to check level front to back and side to side on every course to maintain proper wall batter and alignment. Proper shimming materials can be any non-degradable material including but not limited to, asphalt shingles, scrap pieces of geogrid, etc... Continue backfilling, installing additional units and checking level to the desired top elevation (see Figure A:7). Follow wall unit and unit drainage fill installation closely with backfill. Maximum stacked vertical height of wall units prior to unit drainage fill and backfill placement and compaction shall not exceed 2 courses, unless special construction techniques are employed to insure complete filling of all units with unit drainage fill. For gravity walls continue this construction sequence to complete the wall, and proceed to Step 10. For geogrid reinforced walls, continue with Step 8 and Step 9.

FIGURE A:7 - 3D CROSS SECTION WITHOUT REINFORCEMENT

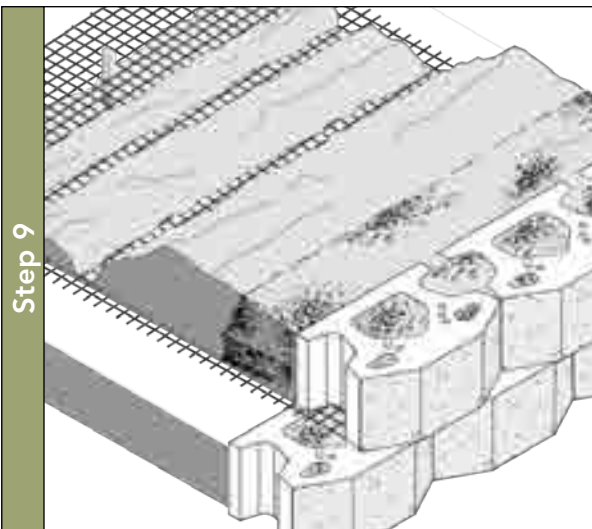


The information contained herein has been compiled by Keystone Retaining Wall Systems® LLC and to the best of our knowledge, accurately represents the Keystone product use in the applications which are illustrated. Final determination of the suitability for the use contemplated and its manner of use are the sole responsibility of the user. Structural design and analysis shall be performed by a qualified engineer.



## 8. Structural Geogrid Installation

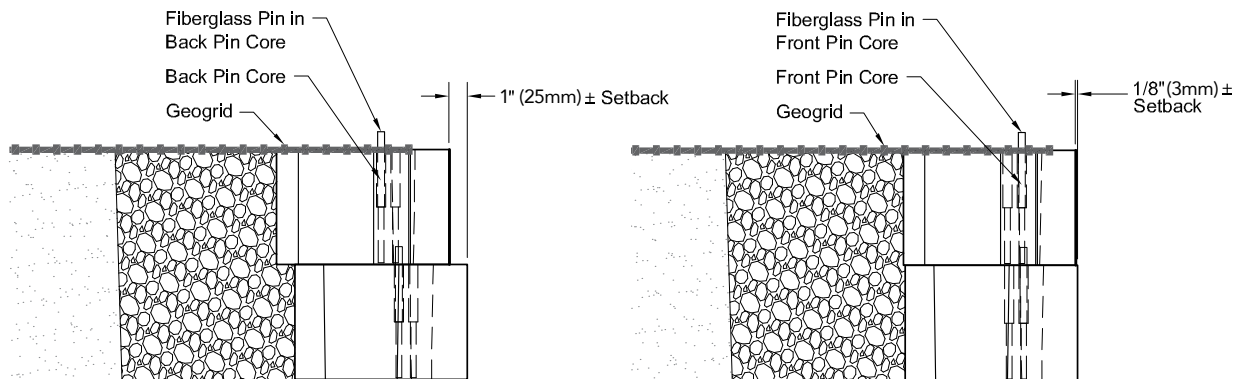
Start at the lowest wall elevation where a geogrid layer will be placed. The geogrid elevations, depths, and strength will be specified in the engineered design for the wall.\* Measure and cut the geogrid material to the specified length. Orient geogrid with highest strength axis perpendicular to the wall alignment. Lay geogrid horizontally on compacted backfill and hook over the pins of the units to within 1" (25mm) of the face of the lower block (see Figure A:8). In general, geogrid will be placed in pieces side-by-side with no gapping, and in a continuous layer along the length of design geogrid elevation, unless a change in elevation is specified in the design. Install an additional course of units over the geogrid. Tension the geogrid by pulling it towards the embankment. Place a stake through the end of the geogrid into the ground or place fill over the back edge of geogrid to hold it taut and in place. Do not excessively tension geogrid: this may pull units out of proper alignment.



## 9. Reinforced Backfill Placement

Proceed with placement of the unit drainage fill and the backfill in the reinforced zone. Specifications for the material to be used as backfill in the reinforced zone should be defined in the engineered plans. Place this material nearest to the units, moving progressively toward the staked end of the geogrid. This procedure will keep the geogrid under tension. Compact the reinforced fill material to 95% Standard Proctor Density (ASTM D698), or 92% Modified Proctor Density (ASTM D1557) or to the compaction requirements in the engineered plans. Install additional courses as described in step 7, until the next reinforcement elevation. Repeat Step 8 and Step 9 (see Figure A:9, page 18). Only hand operated compaction equipment shall be allowed within 3 feet (1m) of the back surface of the units. At the end of each day's operation, grade the backfill away from the wall and direct runoff away from the wall face.

**FIGURE A:8 - SETBACK OPTIONS WITH REINFORCEMENT**



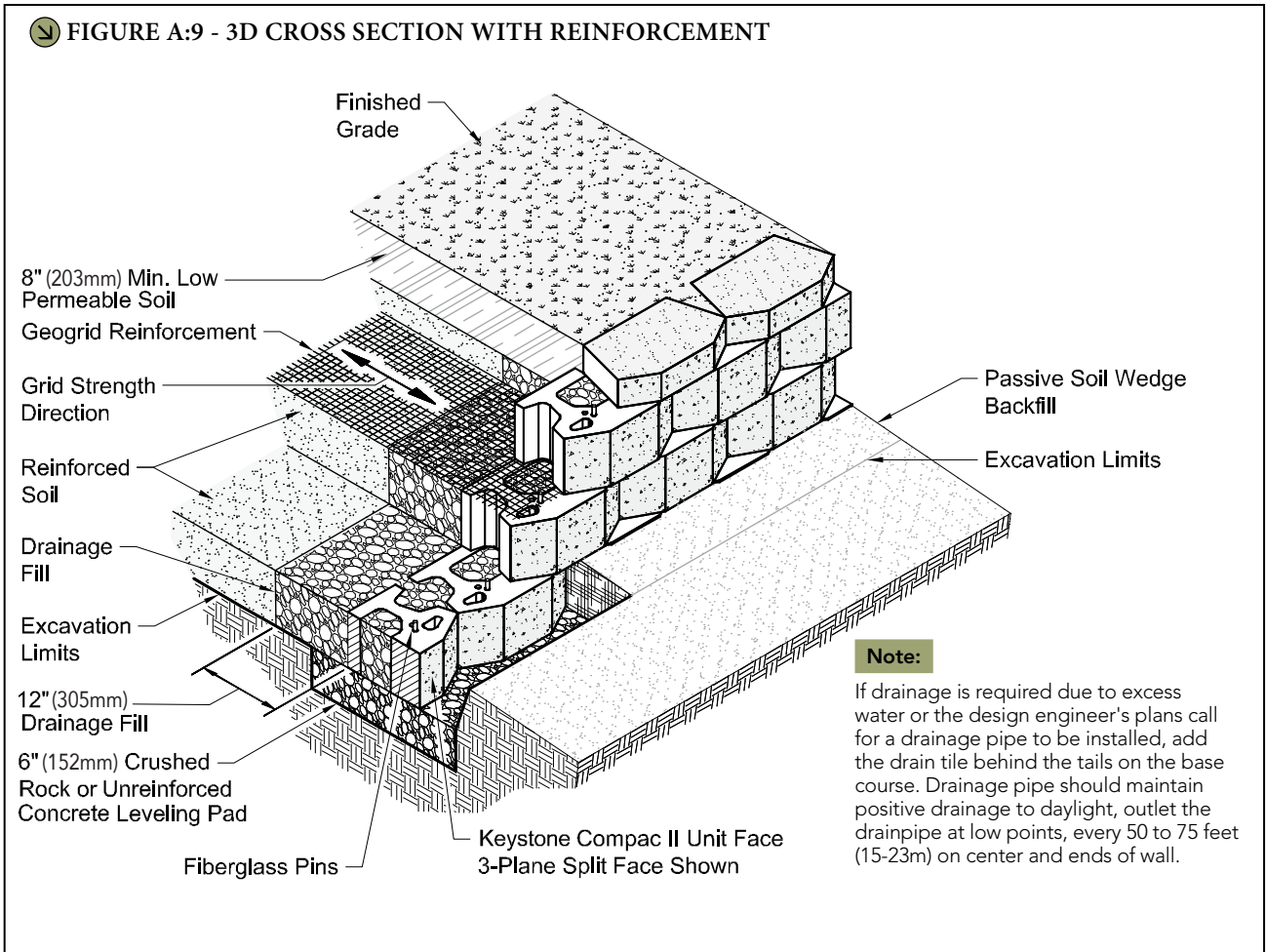
**Note:**

\*For assistance in obtaining engineered drawings for your project, please contact your local Keystone representative.

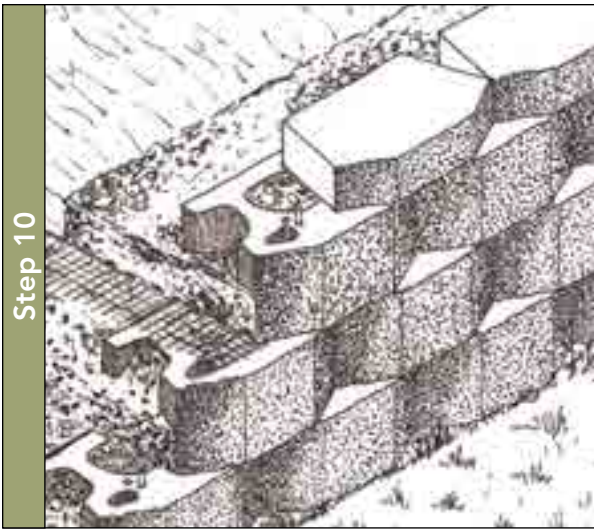
The information contained herein has been compiled by Keystone Retaining Wall Systems® LLC and to the best of our knowledge, accurately represents the Keystone product use in the applications which are illustrated. Final determination of the suitability for the use contemplated and its manner of use are the sole responsibility of the user. Structural design and analysis shall be performed by a qualified engineer.

# Installation: Step-by-Step

FIGURE A:9 - 3D CROSS SECTION WITH REINFORCEMENT

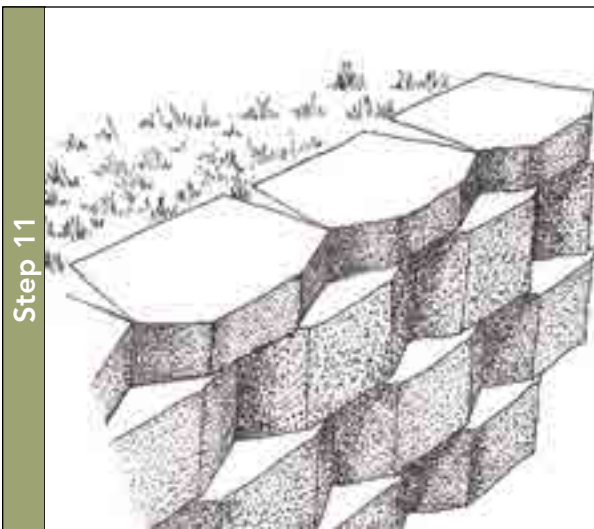


The information contained herein has been compiled by Keystone Retaining Wall Systems® LLC and to the best of our knowledge, accurately represents the Keystone product use in the applications which are illustrated. Final determination of the suitability for the use contemplated and its manner of use are the sole responsibility of the user. Structural design and analysis shall be performed by a qualified engineer.



## 10. Capping the Wall

Complete your wall with the appropriate Keystone capping units. These units are available in a variety of sizes and shapes, including 4 inch (102mm) and 8 inch (203mm) high units. Availability of these units will vary by region. For cap unit descriptions and placement variations see the section, “Wall Finishing” (p. 56) of this manual. Sweep the lower units clean and make sure they are dry. Use exterior grade concrete adhesive on the top surface of the last course before applying cap units (see Figure A:10).

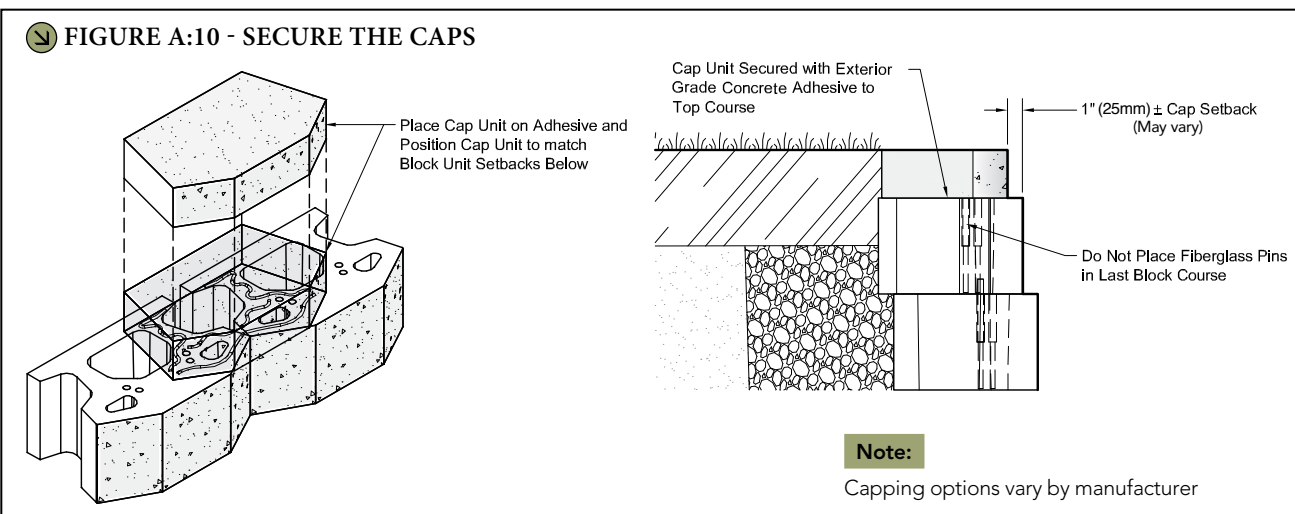


## 11. Finished Grade and Landscaping

The Keystone retaining wall is now complete. Final grading, planting or other surface material can now be put into place. Typically an 8 inch (203mm) thick layer of low permeable soil is installed as the final layer of material. This is to help prevent water infiltration to the retained or reinforced zone of the retaining wall. Remember that finished grade conditions affect the wall’s performance. Such conditions should not be altered from the original design. Loading with slopes, parking lots and buildings should be maintained as designed. Any changes to the top of wall finished grade must be evaluated prior to wall completion (see Figures A:11-A:13 for typical cross section details).

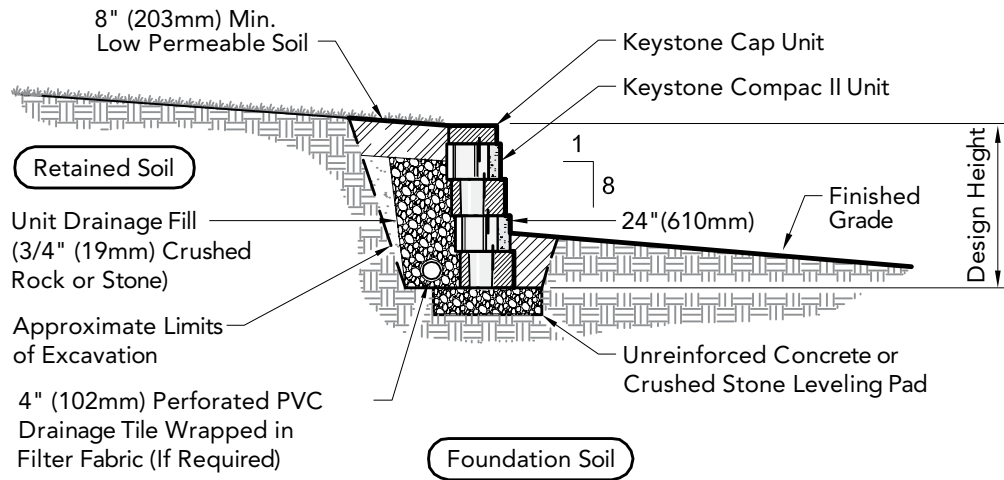
**Note:**

See SECTION F: Specialty - “Planting Guidelines” (p. 85) for details on proper planting installations for a Keystone retaining wall.



# Completed Gravity Wall Section

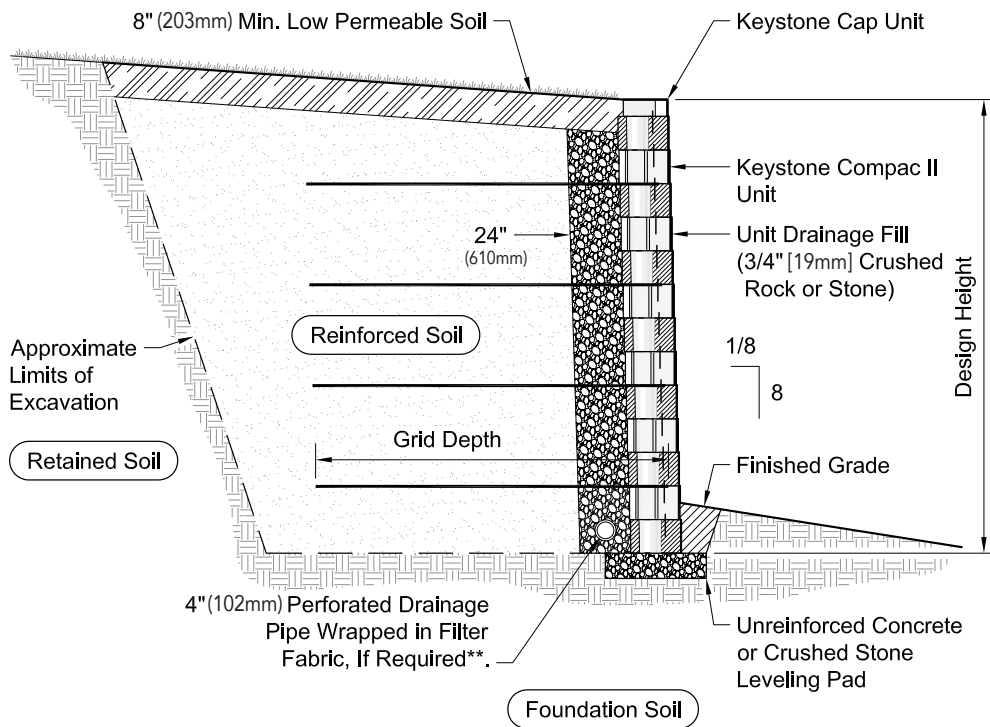
FIGURE A:11 - (GRAVITY WALL) CROSS SECTION



The information contained herein has been compiled by Keystone Retaining Wall Systems® LLC and to the best of our knowledge, accurately represents the Keystone product use in the applications which are illustrated. Final determination of the suitability for the use contemplated and its manner of use are the sole responsibility of the user. Structural design and analysis shall be performed by a qualified engineer.

# Completed Reinforced Wall Sections

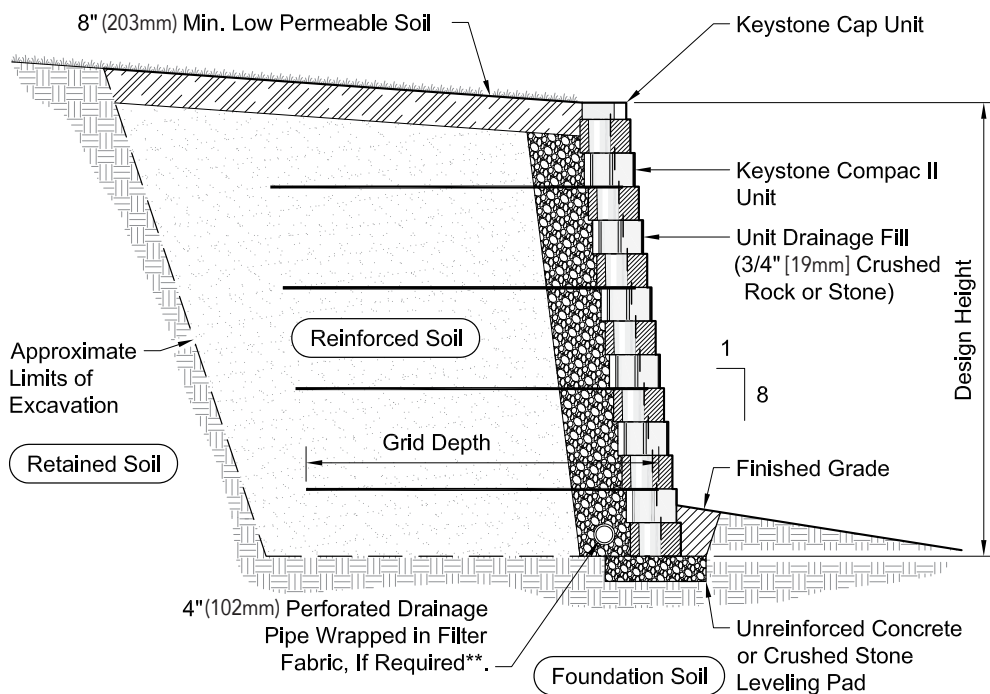
FIGURE A:12 - (REINFORCED WALL) NEAR VERTICAL SETBACK



**Note:**

\*\* For most installations the site geotechnical engineer will direct a drainage pipe to be installed directly behind the wall face at the base of the wall. Piping shall outlet to project storm sewers or daylight at low points in the wall. For other potential drainage conditions that require additional drainage provisions for the wall, see Specialty - Water & Drainage section (pp. 62-65).

FIGURE A:13 - (REINFORCED WALL) 1" (25mm) SETBACK



**Note:**

\*\* For most installations the site geotechnical engineer will direct a drainage pipe to be installed directly behind the wall face at the base of the wall. Piping shall outlet to project storm sewers or daylight at low points in the wall. For other potential drainage conditions that require additional drainage provisions for the wall, see Specialty - Water & Drainage section (pp. 62-65).

The information contained herein has been compiled by Keystone Retaining Wall Systems® LLC and to the best of our knowledge, accurately represents the Keystone product use in the applications which are illustrated. Final determination of the suitability for the use contemplated and its manner of use are the sole responsibility of the user. Structural design and analysis shall be performed by a qualified engineer.





## SECTION B

# DESIGN / ESTIMATING CHARTS

**T**his section contains Keystone's design/estimating charts for Keystone Compac and Keystone Standard unit series gravity walls or geogrid reinforced walls.

The gravity wall charts help determine the maximum possible gravity wall height for a Keystone Compac or Keystone Standard unit. First, select which unit will be used for the wall. Second, determine which soil type most closely represents the soil conditions on the project site. Finally, select the backslope condition that most closely represents the final constructed wall condition.

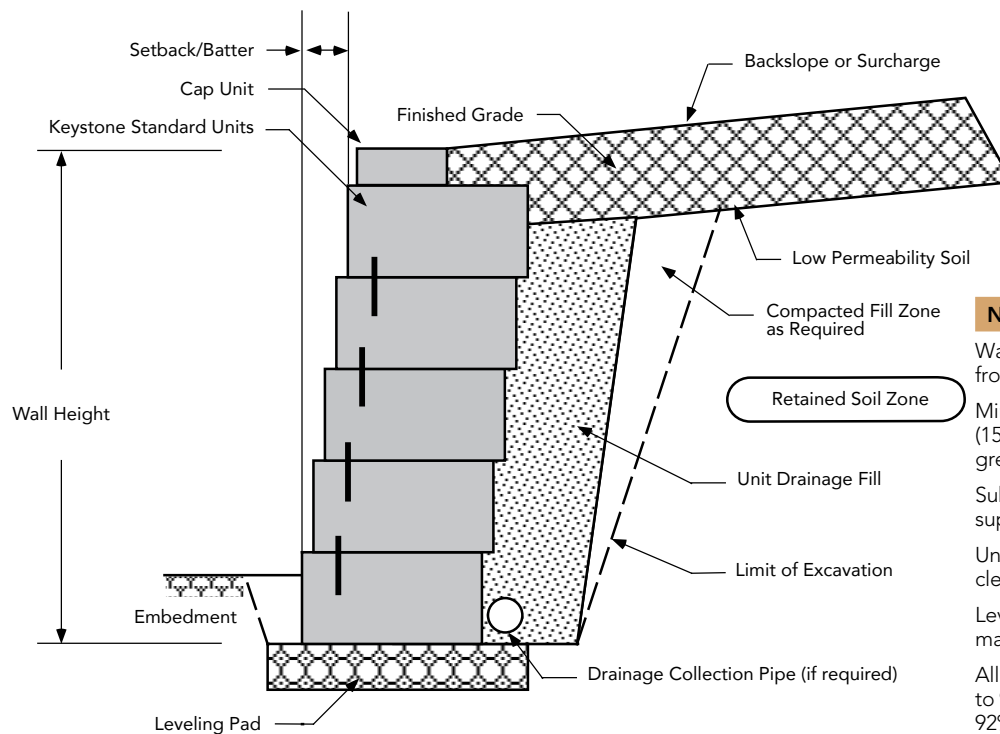
The reinforced wall charts consider multiple factors for determining the necessary geogrid length. First, select the appropriate unit type and wall batter. Next, determine the wall load condition that most closely resembles the final project conditions. Then select the soil condition that most closely matches the project site soils. Finally, select the wall height (including embedment) that will best fit the project wall profile.

The design/estimating charts in this section are to be used for reference and preliminary design use only. These charts are not to be considered as a standardized engineering document. A qualified professional should be consulted for final design assistance. Keystone accepts no liability for the use of these charts.

# Gravity Wall Schematic



**GRAVITY WALL SCHEMATIC**

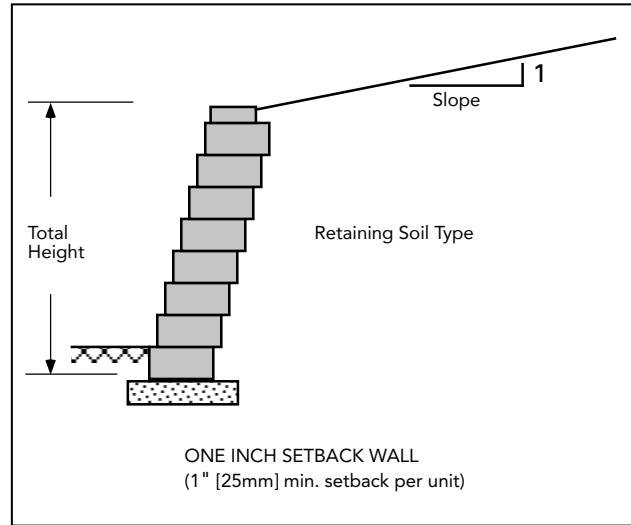
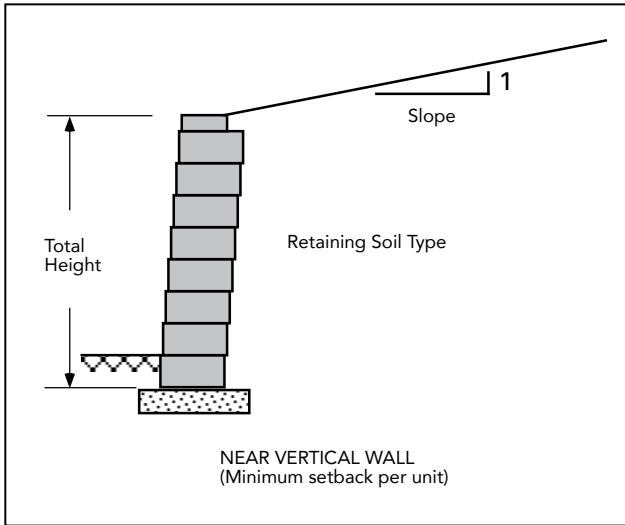


**NOTES:**

- Wall Height (H) is the total height from top to bottom.
- Minimum wall embedment is 6 inches (152mm) or Height/8, whichever is greater for level toe.
- Subsurface soils must be capable of supporting wall system.
- Unit drainage fill is ¾ inch (19mm) clean crushed stone.
- Leveling pad is crushed stone base material.
- All backfill materials are compacted to 95% Standard Proctor Density or 92% Modified Proctor Density.
- Finished grade must provide positive drainage.

The information contained herein has been compiled by Keystone Retaining Wall Systems® LLC and to the best of our knowledge, accurately represents the Keystone product use in the applications which are illustrated. Final determination of the suitability for the use contemplated and its manner of use are the sole responsibility of the user. Structural design and analysis shall be performed by a qualified engineer.

# Maximum Height Gravity Wall Charts



NEAR VERTICAL - KEystone STANDARD UNITS-18" (457mm)

MAX. HGT.	BACKSLOPE				
	Soil Type	Level	4H:1V	3H:1V	2H:1V
Sand/Gravel	4.33' (1.3m)	3.67' (1.1m)	3.67' (1.1m)	3.00' (0.9m)	
Silty Sand	3.67' (1.1m)	3.00' (0.9m)	3.00' (0.9m)	3.00' (0.9m)	
Silt/Lean Clay	3.67' (1.1m)	3.00' (0.9m)	3.00' (0.9m)	<1.00' (0.3m)	

SETBACK OPTION - KEystone STANDARD UNITS-18" (457mm)

MAX. HGT.	BACKSLOPE				
	Soil Type	Level	4H:1V	3H:1V	2H:1V
Sand/Gravel	5.67' (1.7m)	5.00' (1.5m)	5.00' (1.5m)	4.33' (1.3m)	
Silty Sand	5.00' (1.5m)	4.33' (1.3m)	4.33' (1.3m)	3.67' (1.1m)	
Silt/Lean Clay	4.33' (1.3m)	3.67' (1.1m)	3.00' (0.9m)	2.33' (0.7m)	

NEAR VERTICAL - KEystone STANDARD UNITS-21" (533mm)

MAX. HGT.	BACKSLOPE				
	Soil Type	Level	4H:1V	3H:1V	2H:1V
Sand/Gravel	5.00' (1.5m)	4.33' (1.3m)	4.33' (1.3m)	3.67' (1.1m)	
Silty Sand	4.33' (1.3m)	3.67' (1.1m)	3.67' (1.1m)	3.00' (0.9m)	
Silt/Lean Clay	3.67' (1.1m)	3.67' (1.1m)	3.00' (0.9m)	2.33' (0.7m)	

SETBACK OPTION - KEystone STANDARD UNITS-21" (533mm)

MAX. HGT.	BACKSLOPE				
	Soil Type	Level	4H:1V	3H:1V	2H:1V
Sand/Gravel	7.00' (2.1m)	6.33' (1.9m)	5.67' (1.7m)	5.00' (1.5m)	
Silty Sand	5.67' (1.7m)	5.00' (1.5m)	5.00' (1.5m)	4.33' (1.3m)	
Silt/Lean Clay	5.00' (1.5m)	4.33' (1.3m)	3.67' (1.1m)	3.00' (0.9m)	

**NOTES:**

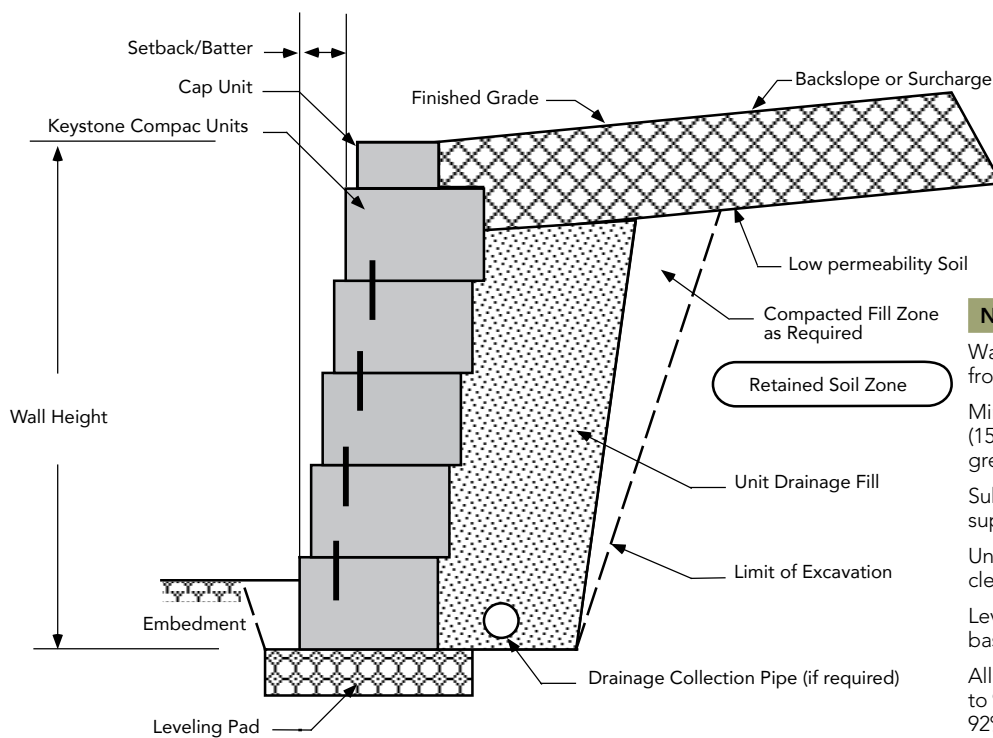
Calculations assume a unit weight of 120 Pcf (19kN/M<sup>2</sup>) for all soil types. Assumed  $\phi$  angles for earth pressure calculations are: Sand/Gravel=34°, Silty Sand=30°, and Sandy Silt/Lean Clay=26°. Non-critical structures with FS>1.5. Gravity wall charts are performed using coulomb earth pressure analysis. (NCMA 3rd Edition) Near vertical walls utilize 1° batter and 1" (25mm) setback walls utilize 8° batter. No surcharges were used in the analysis. Surcharges or special loading conditions will reduce maximum wall heights. Sliding calculations assume a 6" (152mm) crushed stone leveling pad as compacted foundation material. The information provided is for preliminary design use only. A qualified professional should be consulted. Keystone accepts no liability for the use of these tables.

The information contained herein has been compiled by Keystone Retaining Wall Systems® LLC and to the best of our knowledge, accurately represents the Keystone product use in the applications which are illustrated. Final determination of the suitability for the use contemplated and its manner of use are the sole responsibility of the user. Structural design and analysis shall be performed by a qualified engineer.

# Gravity Wall Schematic



## GRAVITY WALL SCHEMATIC



### NOTES:

Wall Height (H) is the total height from top to bottom.

Minimum wall embedment is 6 inches (150mm) or Height/8, whichever is greater for level toe.

Subsurface soils must be capable of supporting wall system.

Unit drainage fill is ¾ inch (20mm) clean crushed stone.

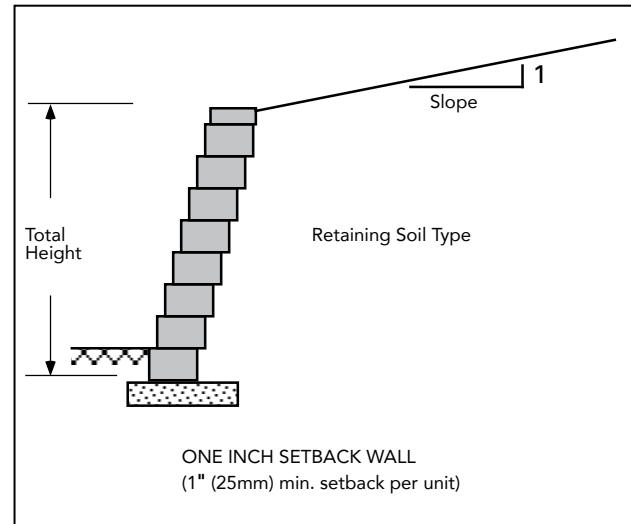
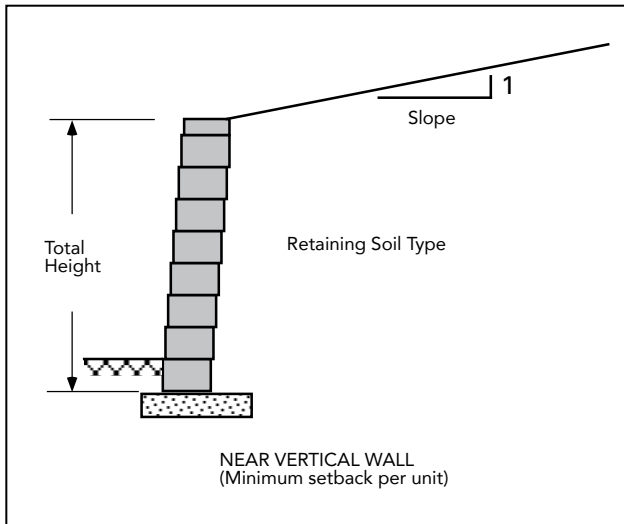
Leveling pad is crushed stone base material.

All backfill materials are compacted to 95% Standard Proctor Density or 92% Modified Proctor Density.

Finished grade must provide positive drainage.

The information contained herein has been compiled by Keystone Retaining Wall Systems® LLC and to the best of our knowledge, accurately represents the Keystone product use in the applications which are illustrated. Final determination of the suitability for the use contemplated and its manner of use are the sole responsibility of the user. Structural design and analysis shall be performed by a qualified engineer.

# Maximum Height Gravity Wall Charts



## NEAR VERTICAL - KEystone COMPAC UNITS

MAX. HGT.	BACKSLOPE				
	Soil Type	Level	4H:1V	3H:1V	2H:1V
Sand/Gravel	3.00' (0.9m)	2.33' (0.7m)	2.33' (0.7m)	2.33' (0.7m)	2.33' (0.7m)
Silty Sand	2.33' (0.7m)	2.33' (0.7m)	1.67' (0.5m)	1.67' (0.5m)	1.67' (0.5m)
Silt/Lean Clay	2.33' (0.7m)	1.67' (0.5m)	1.67' (0.5m)	<1.00' (0.3m)	<1.00' (0.3m)

## SETBACK OPTION - KEystone COMPAC UNITS

MAX. HGT.	BACKSLOPE				
	Soil Type	Level	4H:1V	3H:1V	2H:1V
Sand/Gravel	3.67' (1.1m)	3.67' (1.1m)	3.00' (0.9m)	3.00' (0.9m)	3.00' (0.9m)
Silty Sand	3.00' (0.9m)	3.00' (0.9m)	3.00' (0.9m)	2.33' (0.7m)	2.33' (0.7m)
Silt/Lean Clay	3.00' (0.9m)	2.33' (0.7m)	2.33' (0.7m)	<1.00' (0.30m)	<1.00' (0.30m)

### NOTES:

Calculations assume a unit weight of 120 Pcf (19kN/M<sup>2</sup>) for all soil types. Assumed  $\phi$  angles for earth pressure calculations are: Sand/Gravel=34°, Silty Sand=30°, and Sandy Silt/Lean Clay=26°. Non-critical structures with FS>1.5. Gravity wall charts are performed using coulomb earth pressure analysis (NCMA 3rd Edition). Near vertical walls utilize 1° batter and 1" (25mm) setback walls utilize 8° batter. No surcharges were used in the analysis. Surcharges or special loading conditions will reduce maximum wall heights. Sliding calculations assume a 6" (152mm) crushed stone leveling pad as compacted foundation material. The information provided is for preliminary design use only. A qualified professional should be consulted. Keystone accepts no liability for the use of these tables.

# Design/Estimating Charts: Reinforced Wall Charts Notes

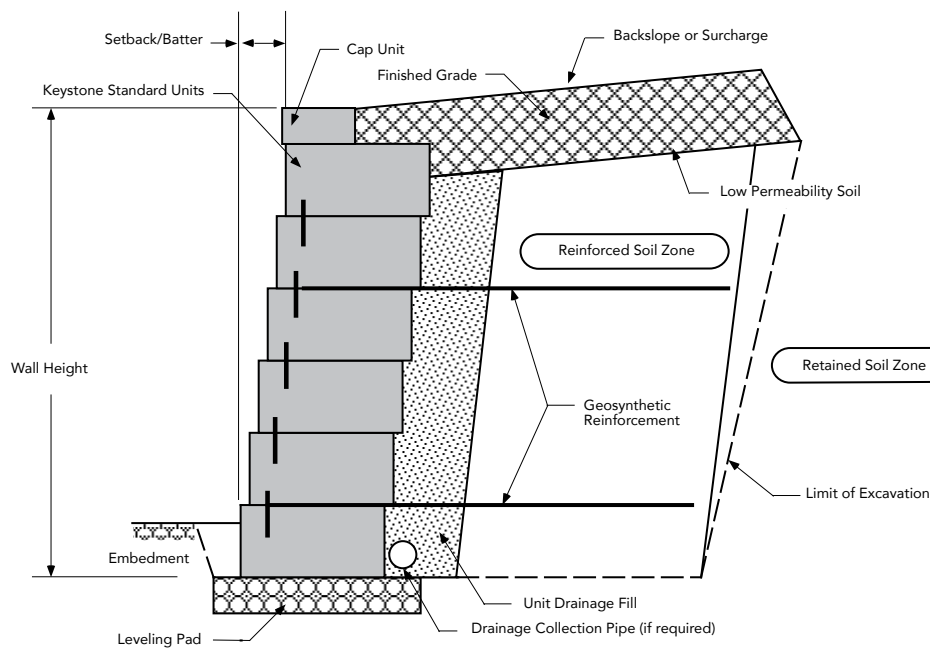
The Keystone reinforced wall charts are graphically presented to show the proper location and lengths of geogrids used with Keystone Standard units at the near vertical and 1 inch (25mm) setback batter (8°). Design heights were set in two block increments beginning at 4.3 feet (1.3m) and ending 11 feet (3.4m). Engineering judgement should be used when interpolating between heights. In general, geogrid should be placed at the design elevation for the entire wall length or until a wall step is reached. Minimum reinforcement lengths were set for 5 feet (1.5m) and a 70% reinforcement length to wall height ratio. Always use the same vertical spacing of geogrid throughout the wall. If your maximum height of wall requires 3 units vertical spacing, then use that spacing even though lower wall heights in the charts may indicate 4 units. Top layers of geogrid shall never be more than 3 units from the top of the wall. Bottom layers of geogrid shall never be more than 3 units from the top of the leveling pad. Insert a geogrid layer at these locations where 3 unit courses are exceeded. 250 psf surcharge is applied 6 inches (152mm) behind the tail of the units. Soil ranges were selected to approximate good, medium and poor soil conditions to cover the typical design range. Wall height is the total height of the wall from the top of the leveling pad to the top of the wall.

The charts use Rankine earth pressure for calculations. The following charts assume the use of a coated polyester geogrid with a minimum allowable design strength of: LTDS=1800 plf (26.3 kN/m) Tal=1200 plf (17.5 kN/m). The following geogrid types are suitable with these design charts:

- » Synteen SF35 by Synteen
- » Miragrid 3XT by TC Mirafi
- » Stratagrid 200 by Strata Systems
- » 55/30-20 by Huesker Inc.

All geogrid lengths shown are the actual lengths of geogrid required as measured from the front wall face to the end of the geogrid. The charts assume that the walls are constructed in accordance with Keystone specifications and good construction practice. All soil zones (reinforced, retained, and foundation) must be compacted in 8 inch (203mm) lifts to 95% Standard Proctor density or 92% Modified Proctor Density as determined by laboratory testing. The information contained in the design/estimating charts are for preliminary design use only. A qualified professional should be consulted for final design assistance. Keystone accepts no liability for the use of these charts.

## REINFORCED WALL SCHEMATIC



### NOTES:

Wall Height (H) is the total height from top to bottom.

Minimum wall embedment is 6 inches (152mm) or Height/20, whichever is greater for level toe.

Subsurface soils must be capable of supporting wall system.

Unit drainage fill is ¾ inch (19mm) clean crushed stone.

Leveling pad is crushed stone base material.

All backfill materials are compacted to 95% Standard Proctor density or 92% Modified Proctor density.

Geogrids must be of appropriate type and length per the design.

Finished grade must provide positive drainage.

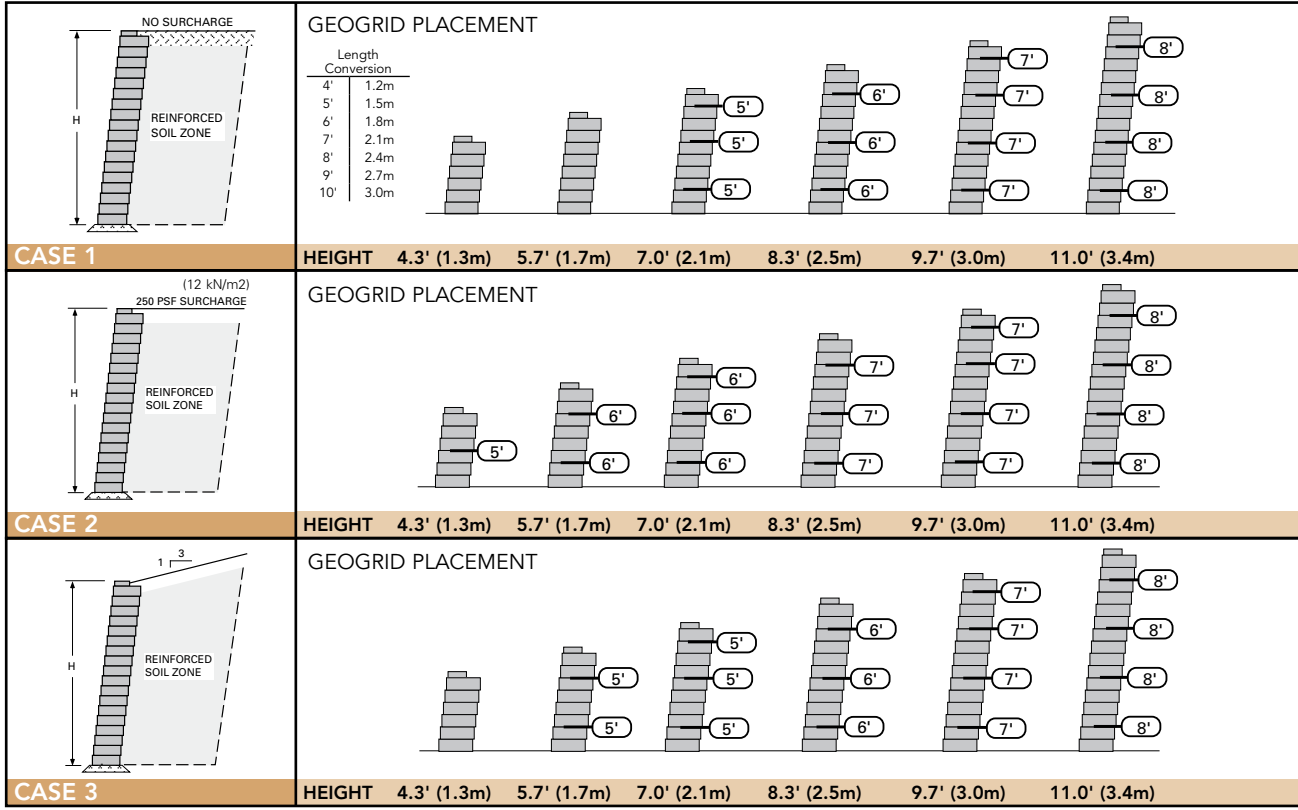
The symbol  $\text{---}5'\text{---}$  indicates location and length of geogrid measured from the front of wall to the end of the geogrid.

The information contained herein has been compiled by Keystone Retaining Wall Systems® LLC and to the best of our knowledge, accurately represents the Keystone product use in the applications which are illustrated. Final determination of the suitability for the use contemplated and its manner of use are the sole responsibility of the user. Structural design and analysis shall be performed by a qualified engineer.

# Design/Estimating Charts: Reinforced Wall Charts

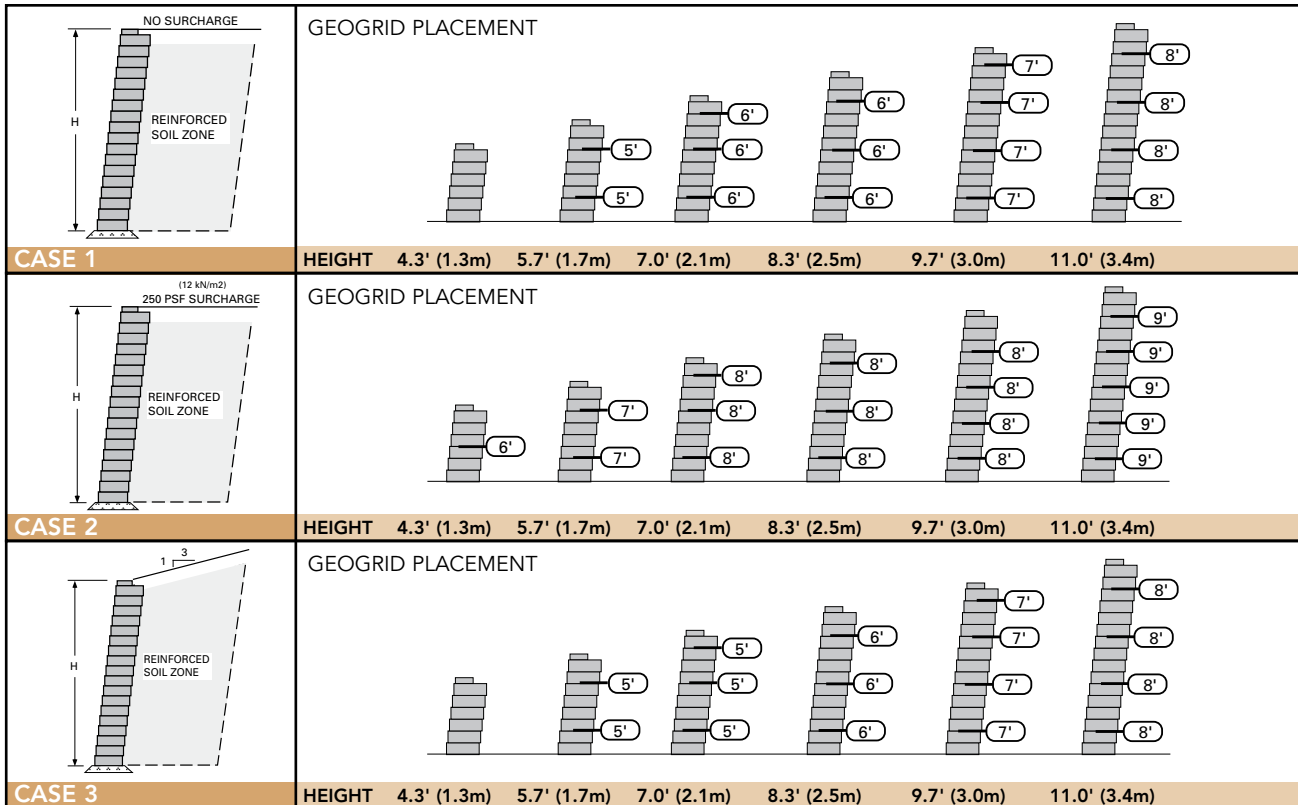
KEYSTONE STANDARD UNITS - 1" (25mm) SETBACK

SAND/GRAVEL:  $\phi=34^\circ$ ,  $\gamma=120$  pcf (19kN/m<sup>3</sup>)



KEYSTONE STANDARD UNITS - 1" (25mm) SETBACK

SILTY SAND:  $\phi=30^\circ$ ,  $\gamma=120$  pcf (19kN/m<sup>3</sup>)

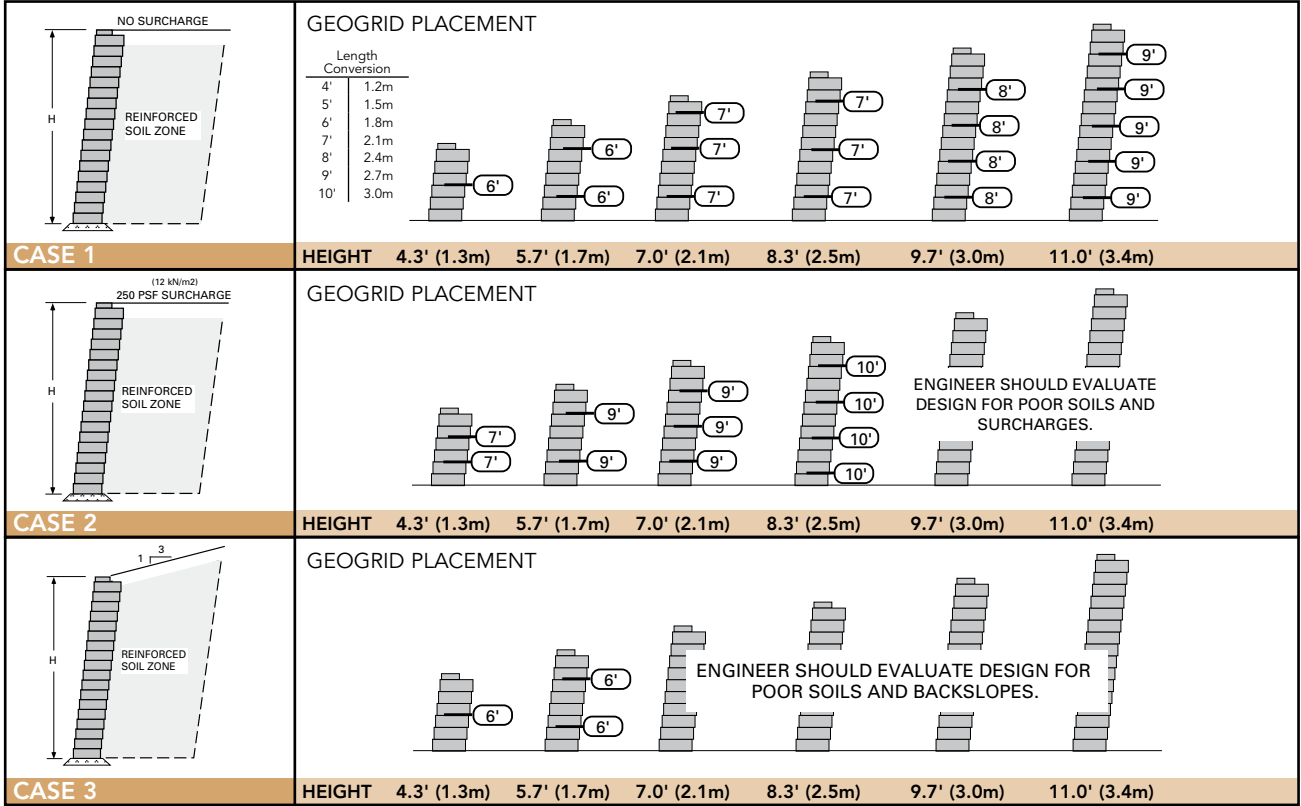


The information contained herein has been compiled by Keystone Retaining Wall Systems® LLC and to the best of our knowledge, accurately represents the Keystone product use in the applications which are illustrated. Final determination of the suitability for the use contemplated and its manner of use are the sole responsibility of the user. Structural design and analysis shall be performed by a qualified engineer.

# Design/Estimating Charts: Reinforced Wall Charts

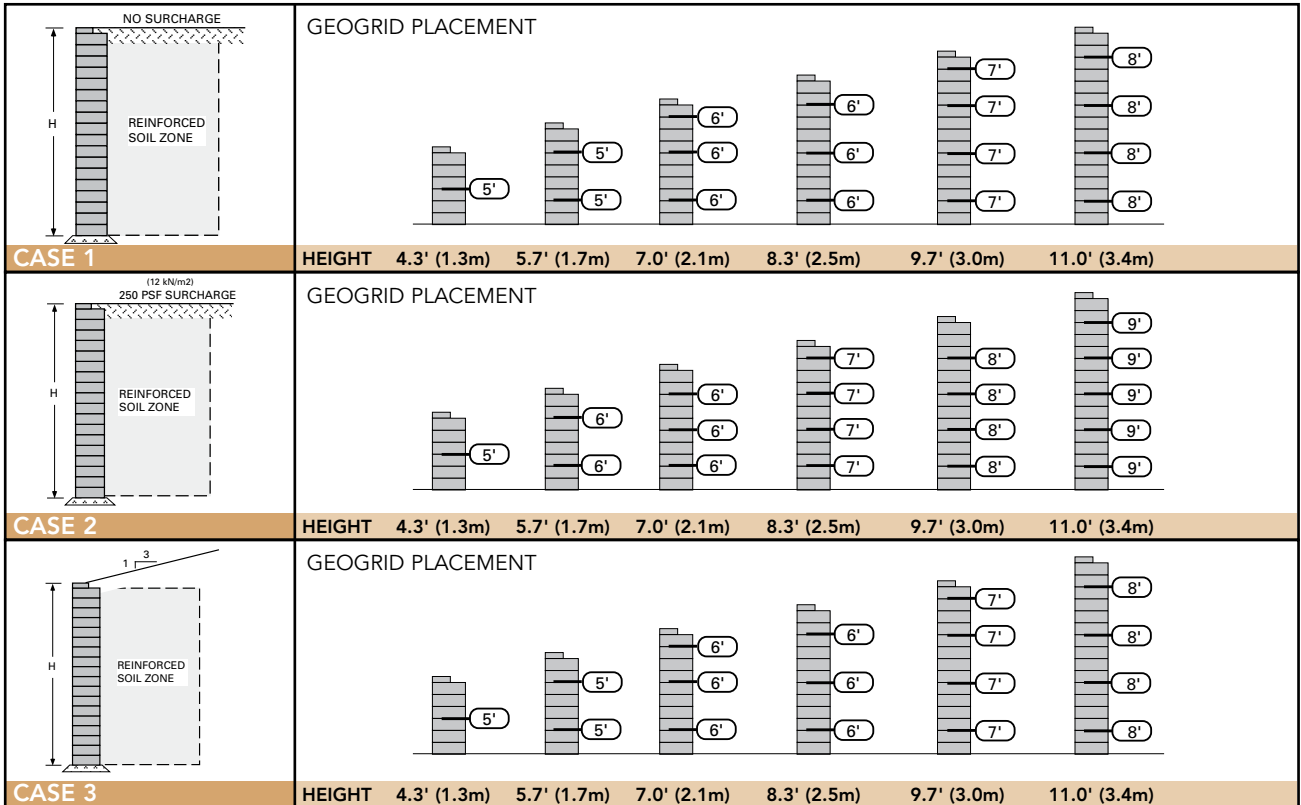
KEYSTONE STANDARD UNITS - 1" (25mm) SETBACK

SILT/LEAN CLAY:  $\phi=26^\circ$ ,  $\gamma=120$  pcf (19kN/m<sup>3</sup>)



KEYSTONE STANDARD UNITS - NEAR VERTICAL

SAND/GRAVEL:  $\phi=34^\circ$ ,  $\gamma=120$  pcf (19kN/m<sup>3</sup>)



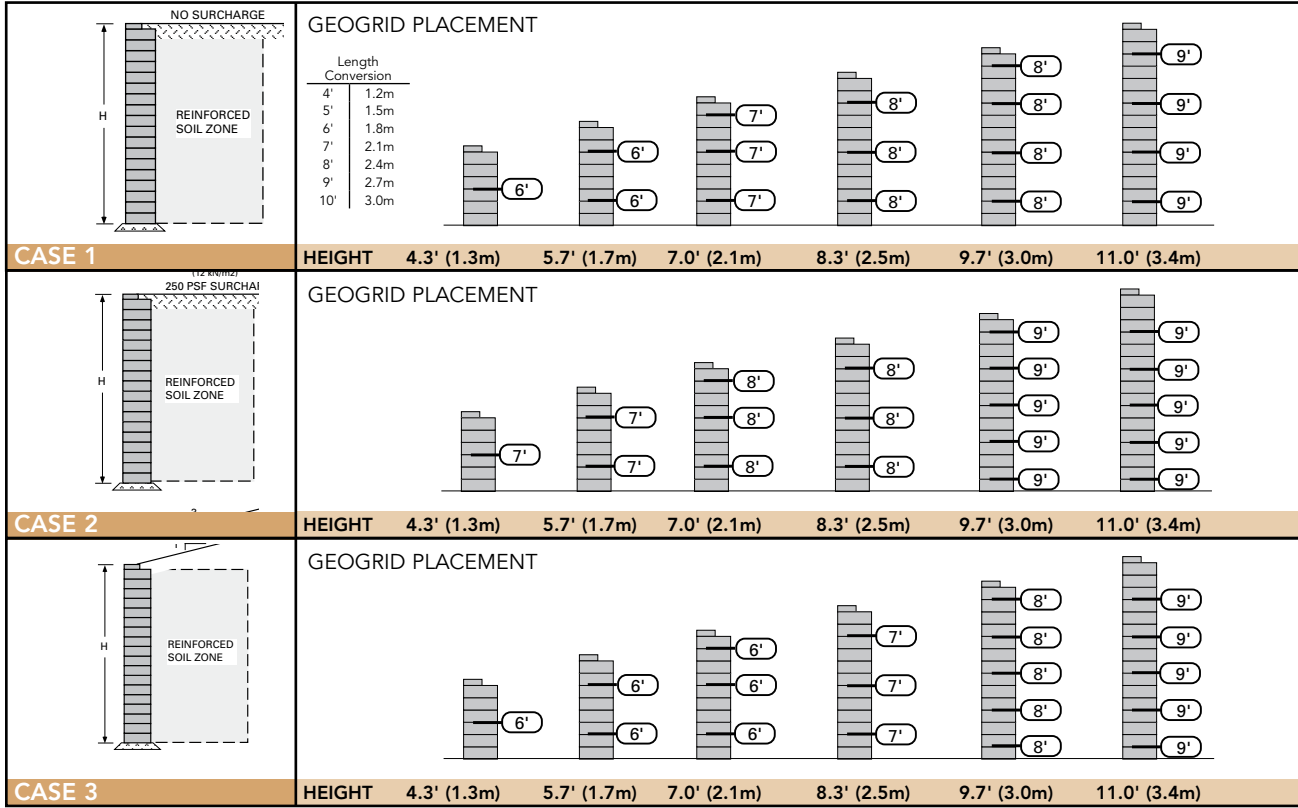
The information contained herein has been compiled by Keystone Retaining Wall Systems® LLC and to the best of our knowledge, accurately represents the Keystone product use in the applications which are illustrated. Final determination of the suitability for the use contemplated and its manner of use are the sole responsibility of the user. Structural design and analysis shall be performed by a qualified engineer.



# Design/Estimating Charts: Reinforced Wall Charts

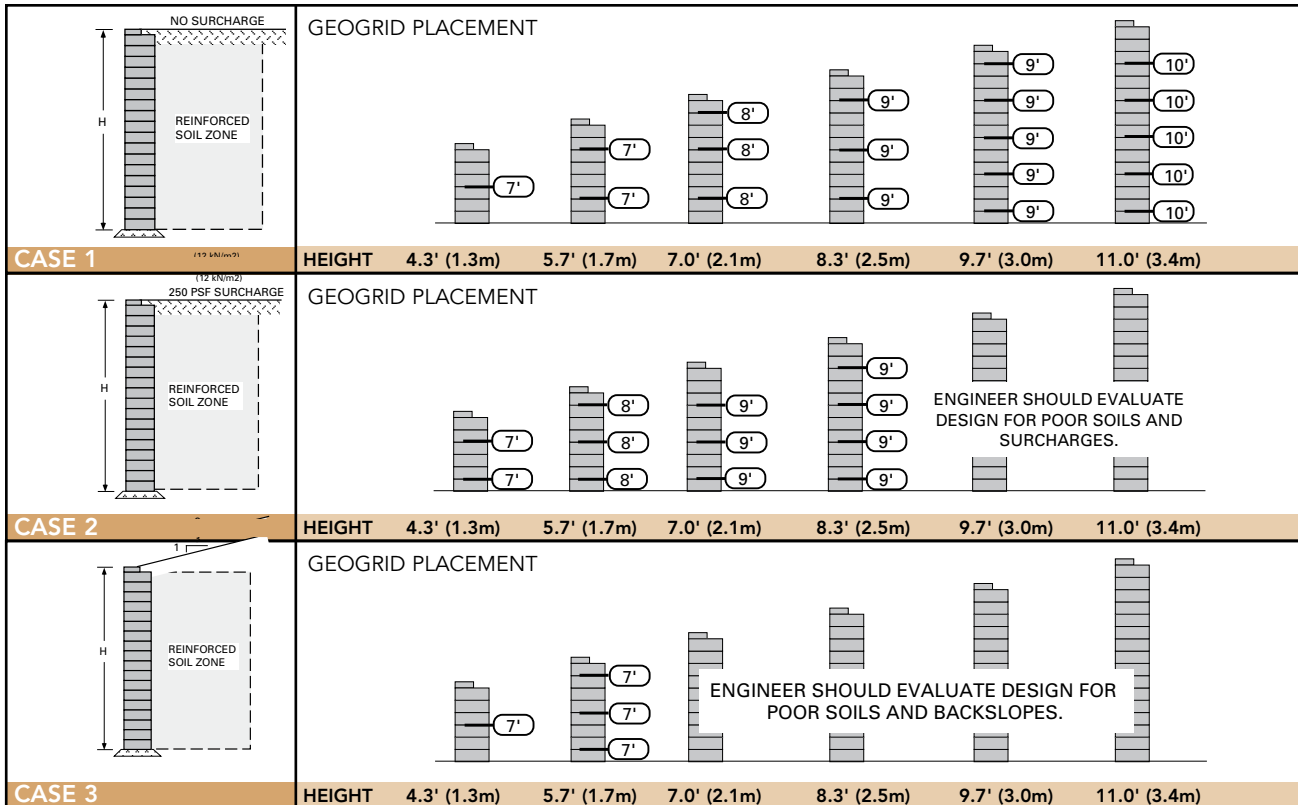
## KEYSTONE STANDARD UNITS - NEAR VERTICAL

SILTY SAND:  $\phi=30^\circ$ ,  $\gamma=120$  pcf (19kN/m<sup>3</sup>)



## KEYSTONE STANDARD UNITS - NEAR VERTICAL

SILTY/LEAN CLAY:  $\phi=26^\circ$ ,  $\gamma=120$  pcf (19kN/m<sup>3</sup>)



The information contained herein has been compiled by Keystone Retaining Wall Systems® LLC and to the best of our knowledge, accurately represents the Keystone product use in the applications which are illustrated. Final determination of the suitability for the use contemplated and its manner of use are the sole responsibility of the user. Structural design and analysis shall be performed by a qualified engineer.

# Design/Estimating Charts : Reinforced Wall Chart Notes

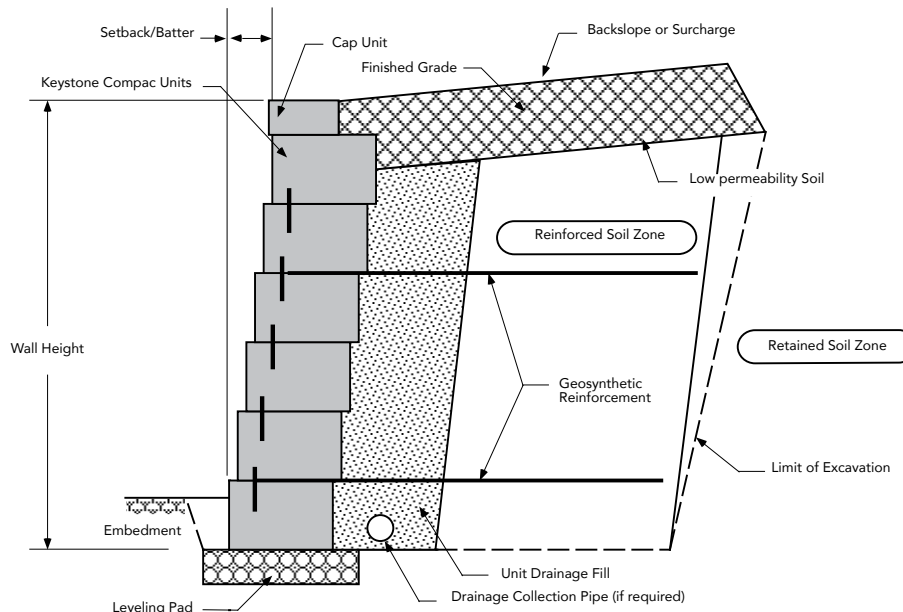
The Keystone reinforced wall charts are graphically presented to show the proper location and lengths of geogrids used with Keystone Compac units at the near vertical and 1 inch (25mm) setback batter (8°). Design heights were set in two block increments beginning at 4.3 feet (1.3m) and ending 11 feet (3.4m). Engineering judgement should be used when interpolating between heights. In general, geogrid should be placed at the design elevation for the entire wall length or until a wall step is reached. Minimum reinforcement lengths were set for 4 feet (1.2m) minimum and a 70% reinforcement length to wall height ratio. Always use the same vertical spacing of geogrid throughout the wall. Top layers of geogrid shall never be more than 2 units from the top of the wall. Bottom layers of geogrid shall never be more than 2 units from the top of the leveling pad. Insert a geogrid layer at these locations where 2 unit courses are exceeded. 250 psf surcharge is applied 6 inches (152mm) behind the tail of the units. Soil ranges were selected to approximate good, medium and poor soil conditions to cover the typical design range. Wall height is the total height of the wall from the top of the leveling pad to top of wall.

The charts use Rankine earth pressure for calculations. The following charts assume the use of a coated polyester geogrid with a minimum allowable design strength of: LTDS=1875 plf (27.4 kN/m) Tal=1250 plf (18.3 kN/m). The following geogrid types are suitable with these design charts:

- » Synteen SF35 by Synteen
- » Miragrid 3XT by TC Mirafi
- » Stratagrid 200 by Strata Systems
- » 55/30-20 by Huesker Inc.

All geogrid lengths shown are the actual lengths of geogrid required as measured from the front wall face to the end of the geogrid. The design/estimating charts assume that the walls are constructed in accordance with Keystone specifications and good construction practice. All soil zones (reinforced, retained, and foundation) must be compacted in 8 inch (203mm) lifts to 95% Standard Proctor density or 92% Modified Proctor Density as determined by laboratory testing. The information contained in the design/estimating charts are for preliminary design use only. A qualified professional should be consulted for final design assistance. Keystone accepts no liability for the use of these charts.

## REINFORCED WALL SCHEMATIC



### NOTES:

Wall Height (H) is the total height from top to bottom.

Minimum wall embedment is 6 inches (152mm) or Height/20, whichever is greater for level toe.

Subsurface soils must be capable of supporting wall system.

Unit drainage fill is ¾ inch (19mm) clean crushed stone.

Leveling pad is crushed stone base material.

All backfill materials are compacted to 95% Standard Proctor density or 92% Modified Proctor density.

Geogrids must be of appropriate type and length per the design.

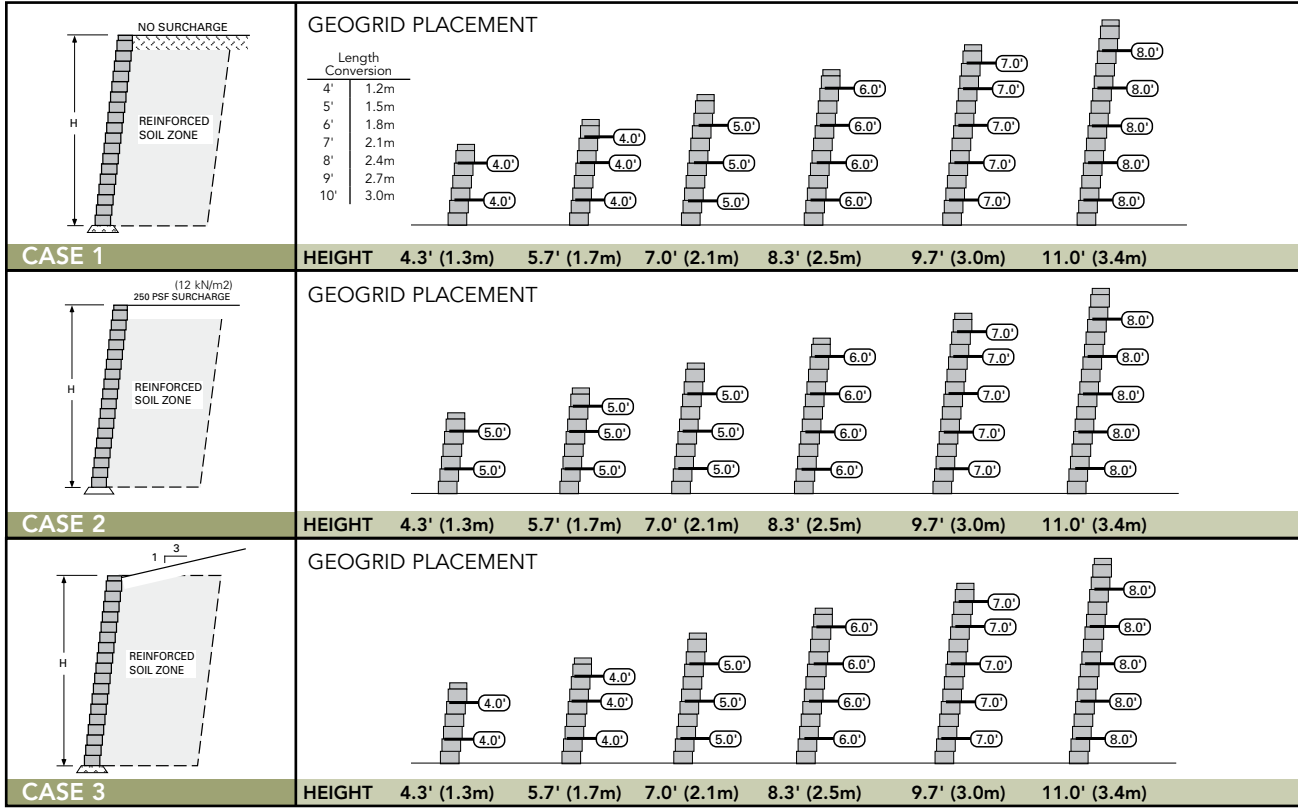
Finished grade must provide positive drainage.

The symbol  $\left(5'\right)$  indicates location and length of geogrid measured from the front of wall to the end of the geogrid.

# Design/Estimating Charts : Reinforced Wall Charts

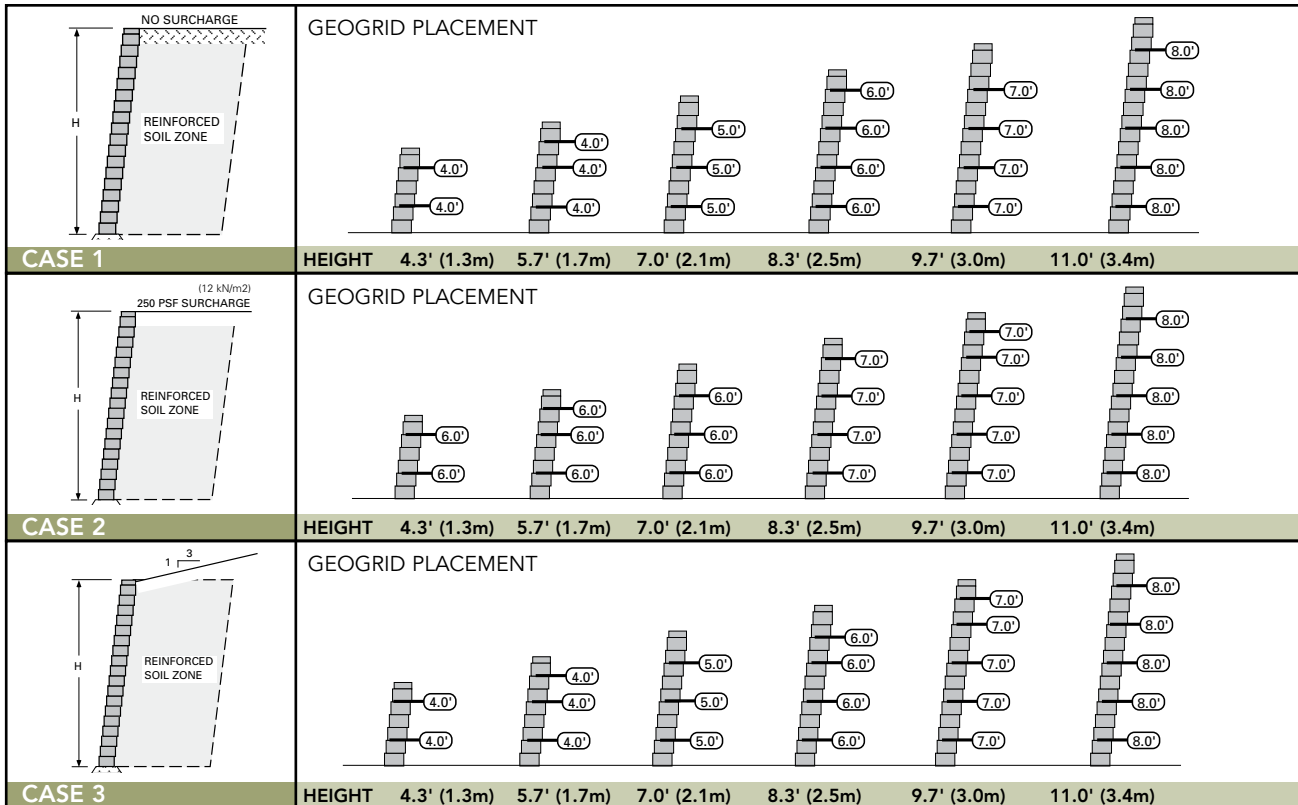
KEYSTONE COMPAC UNITS - 1" (25mm) SETBACK

SAND/GRAVEL:  $\phi=34^\circ$ ,  $\gamma=120$  pcf ( $19\text{kN/m}^3$ )



KEYSTONE COMPAC UNITS - 1" (25mm) SETBACK

SILTY SAND:  $\phi=30^\circ$ ,  $\gamma=120$  pcf ( $19\text{kN/m}^3$ )

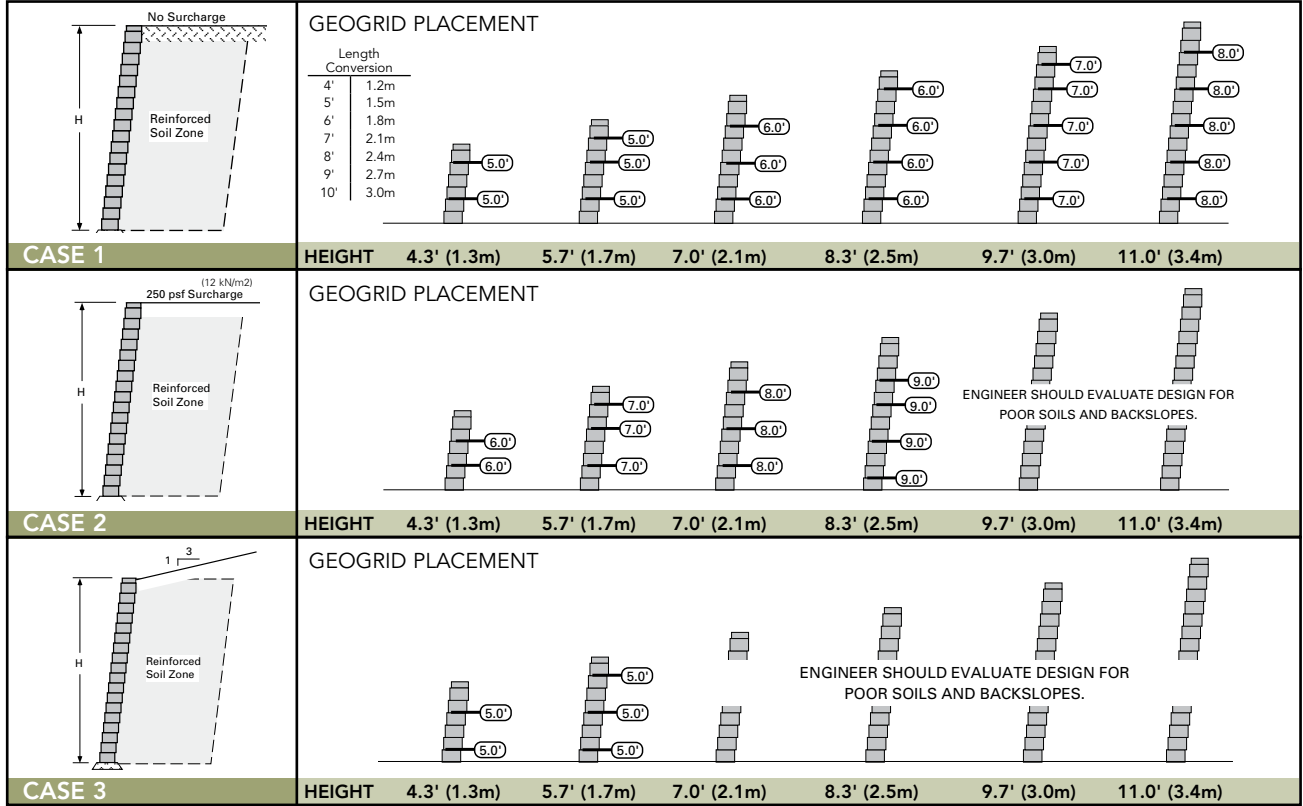


The information contained herein has been compiled by Keystone Retaining Wall Systems® LLC and to the best of our knowledge, accurately represents the Keystone product use in the applications which are illustrated. Final determination of the suitability for the use contemplated and its manner of use are the sole responsibility of the user. Structural design and analysis shall be performed by a qualified engineer.

# Design/Estimating Charts : Reinforced Wall Charts

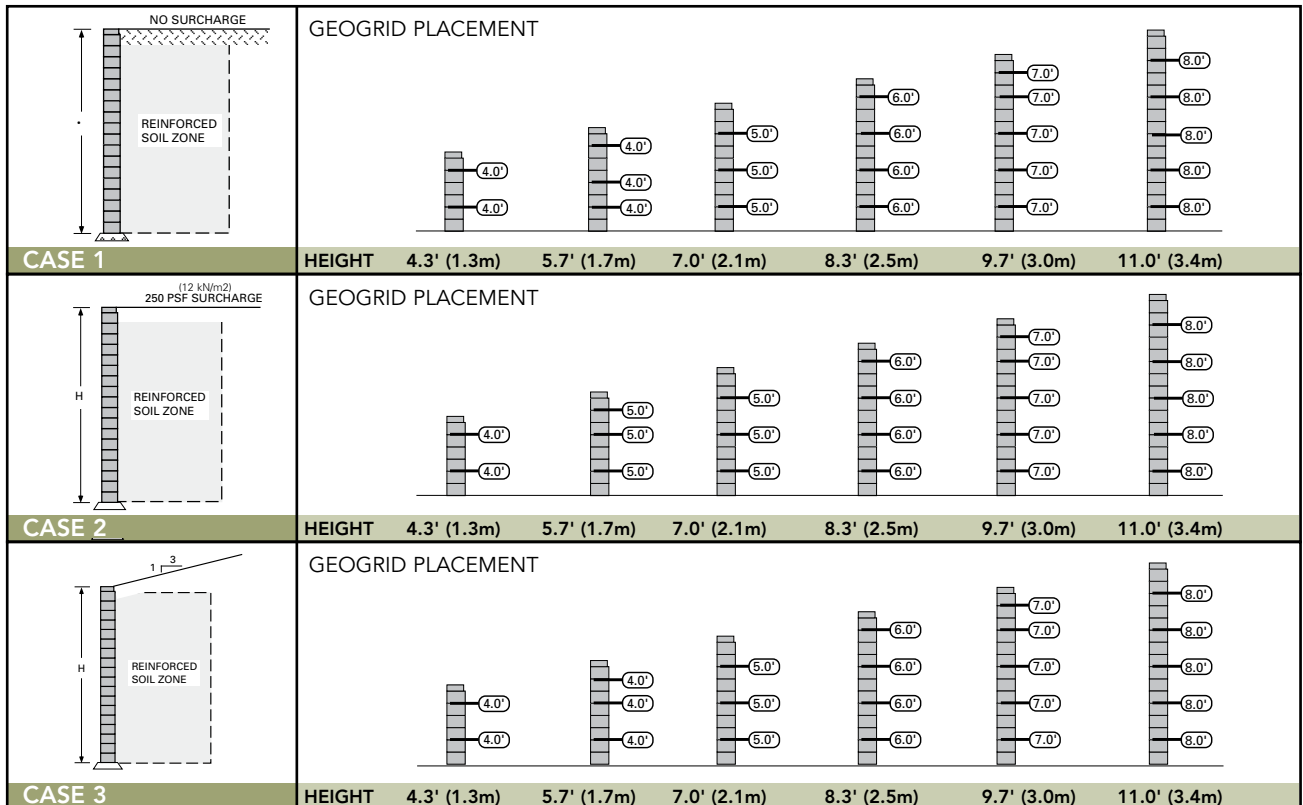
## KEYSTONE COMPAC UNITS - 1" (25mm) SETBACK

SILT/LEAN CLAY:  $\phi=26^\circ$ ,  $\gamma=120$  pcf (19kN/m<sup>3</sup>)



## KEYSTONE COMPAC UNITS - NEAR VERTICAL

SAND/GRAVEL:  $\phi=34^\circ$ ,  $\gamma=120$  pcf (19kN/m<sup>3</sup>)

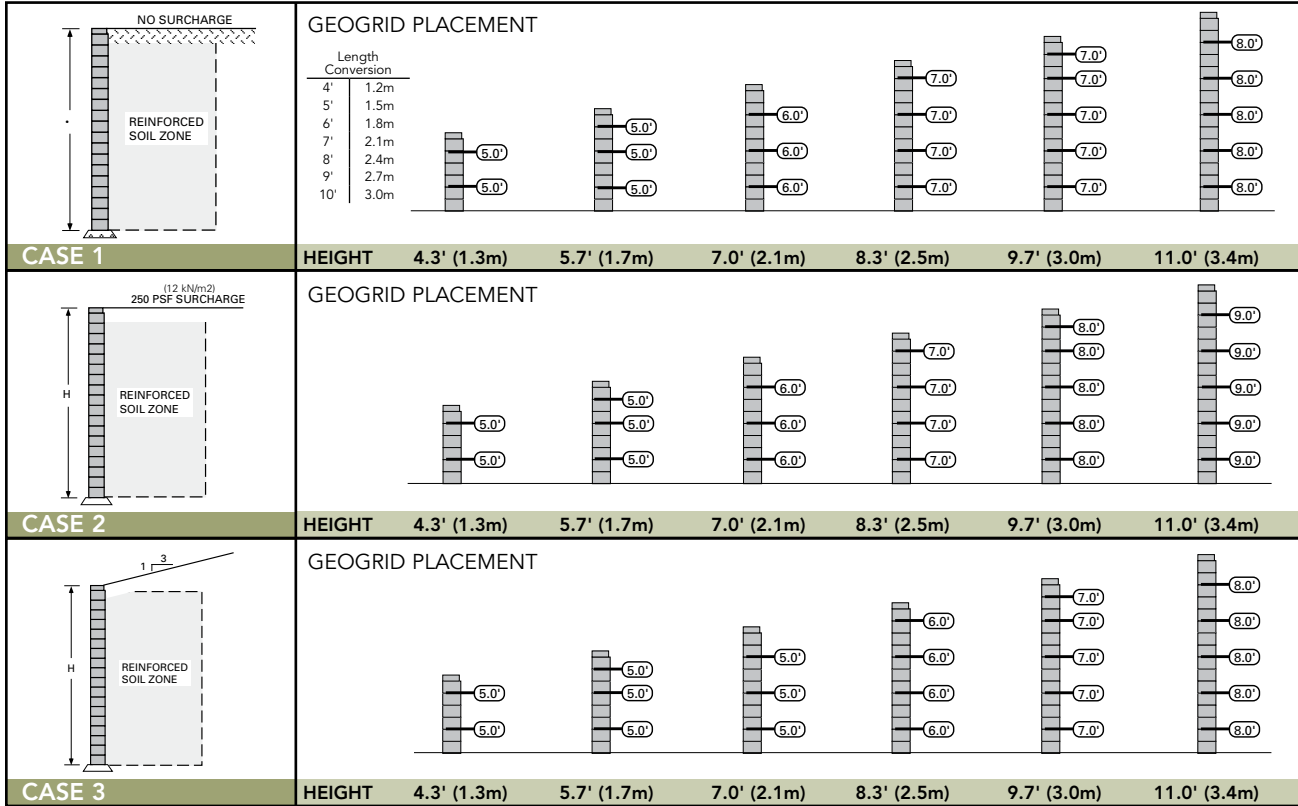


The information contained herein has been compiled by Keystone Retaining Wall Systems® LLC and to the best of our knowledge, accurately represents the Keystone product use in the applications which are illustrated. Final determination of the suitability for the use contemplated and its manner of use are the sole responsibility of the user. Structural design and analysis shall be performed by a qualified engineer.

# Design/Estimating Charts : Reinforced Wall Charts

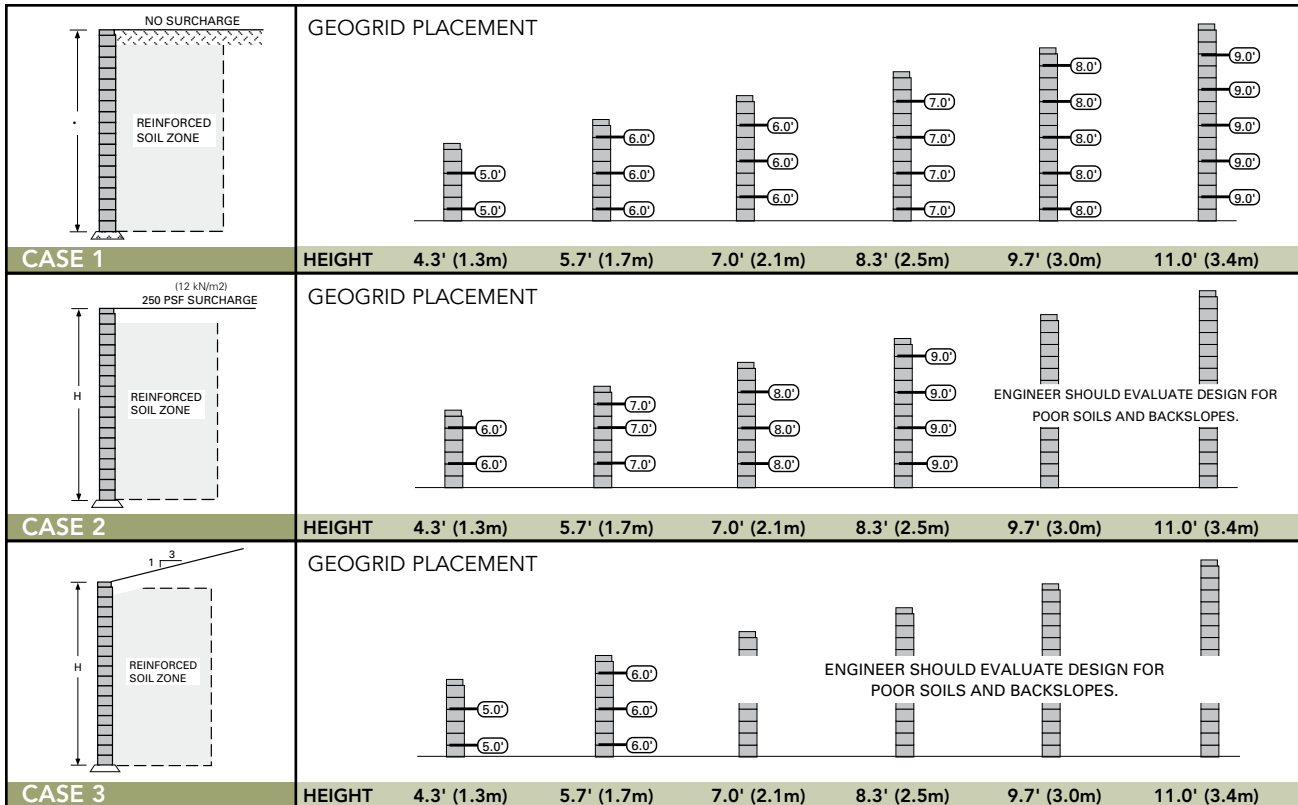
## KEYSTONE COMPAC UNITS - NEAR VERTICAL

SILTY SAND:  $\phi=30^\circ$ ,  $\gamma=120$  pcf ( $19\text{kN/m}^3$ )



## KEYSTONE COMPAC UNITS - NEAR VERTICAL

SILTY/LEAN CLAY:  $\phi=26^\circ$ ,  $\gamma=120$  pcf ( $19\text{kN/m}^3$ )



The information contained herein has been compiled by Keystone Retaining Wall Systems® LLC and to the best of our knowledge, accurately represents the Keystone product use in the applications which are illustrated. Final determination of the suitability for the use contemplated and its manner of use are the sole responsibility of the user. Structural design and analysis shall be performed by a qualified engineer.



KEYSTONE CENTURY WALL®

## SECTION C

# CONSTRUCTION OF CORNERS AND CURVES

---

**S**o far the discussion regarding the installation of a Keystone retaining wall has centered on the installation of units through the straight line sections of the wall. Equally important to the final aesthetic and function of any wall is the construction of corners and curves.

A corner is typically constructed as either an outside 90° corner, inside 90° corner or acute outside corner (between 75° to 90°). When a wall needs to make a turn greater than 90° it is recommended that a radius curve for the wall be installed. For curves in the wall, Keystone units typically have a minimum radius depending on the face style, which is outlined later in this section by unit type. The flexibility of the Keystone units allows for the construction of multiple corners or curves within the same wall. The following information will provide a general explanation of construction techniques for building retaining walls with corner and curve conditions.

Tools and materials that will be required:

- 12 inch (305mm) and 48 inch levels (1.2m)
- Tape measure
- Concrete saw
- Block splitter
- Masonry cold chisel
- 5 lb (2.3kg) dead blow hammer
- Hammer drill with 5/8 inch (16mm) masonry drill bit
- Exterior grade concrete adhesive

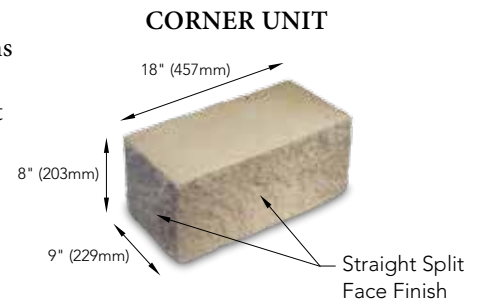
## 90° Outside Corner : Introduction

For ease of construction of outside 90° corners, Keystone producers typically provide a corner unit specifically designed for this purpose. Corner unit options and product designs may vary by manufacturer; please contact your local manufacturer for availability before you begin your project planning. Details at right show a typical corner unit available in many locations.

If corner units are not available, Keystone recommends transitioning the wall from a corner to a radius curve in the wall and avoiding mitered corners. This will enable the wall to maintain its pin connection integrity and running bond wall configuration for continued wall stability and performance.

If creating a radius is not an option, the alternative is to miter the Keystone units to create the outside 90° corner. Unfortunately mitering a corner can result in undesirable wall performance issues in the corner, including gapping of the units, or an entire separation of the wall corner due to soil movement. Keystone recommends using an integration of the mitered Keystone units with rebar and grout or concrete to prevent the unwanted performance issues. Please contact your local Keystone representative for assistance when attempting to construct mitered outside corners.

Battered walls (8°) present an additional challenge in outside corners: as the wall rises vertically, the wall will get smaller. See details on pages 42-43 for detailed installation and cutting instructions.

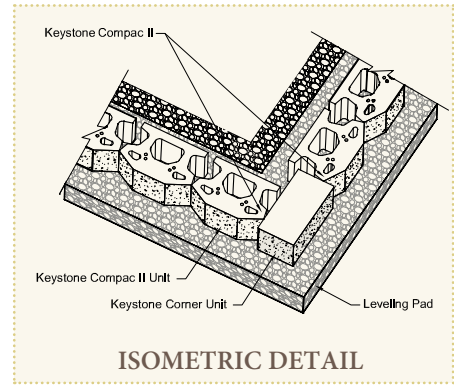
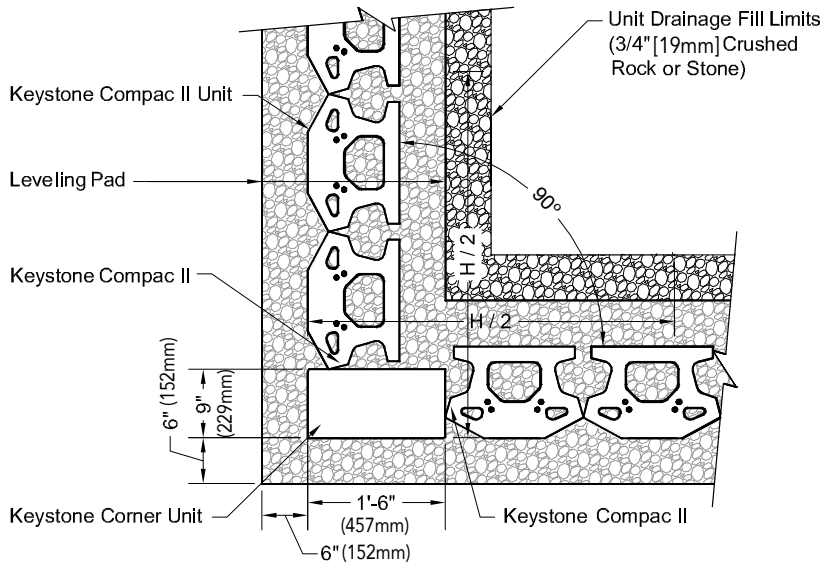


The information contained herein has been compiled by Keystone Retaining Wall Systems® LLC and to the best of our knowledge, accurately represents the Keystone product use in the applications which are illustrated. Final determination of the suitability for the use contemplated and its manner of use are the sole responsibility of the user. Structural design and analysis shall be performed by a qualified engineer.



# 90° Outside Corner : Near Vertical Setback

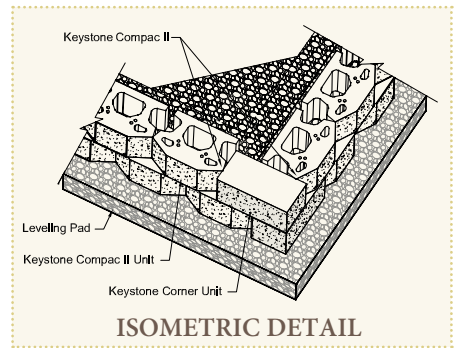
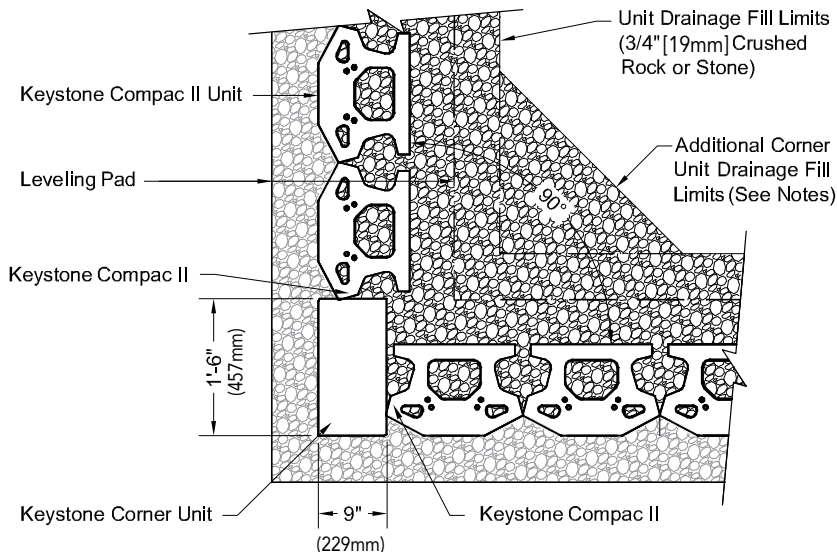
FIGURE C:1 - TYPICAL BASE (ODD COURSES)



**Note:**

See Corner Construction, Figure C:4, for additional detail.

FIGURE C:2 - TYPICAL SECOND (EVEN COURSES)



**Notes:**

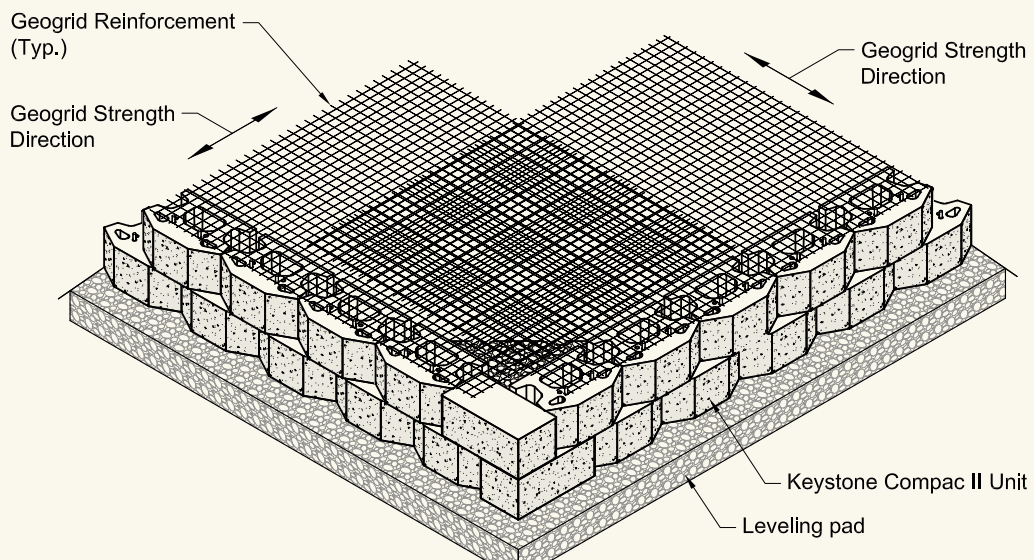
Place additional unit drainage fill at outside wall corner to extend back from wall face each way a distance equal to the wall height / 2 (H / 2).

The information contained herein has been compiled by Keystone Retaining Wall Systems® LLC and to the best of our knowledge, accurately represents the Keystone product use in the applications which are illustrated. Final determination of the suitability for the use contemplated and its manner of use are the sole responsibility of the user. Structural design and analysis shall be performed by a qualified engineer.

# 90° Outside Corner : Near Vertical Setback



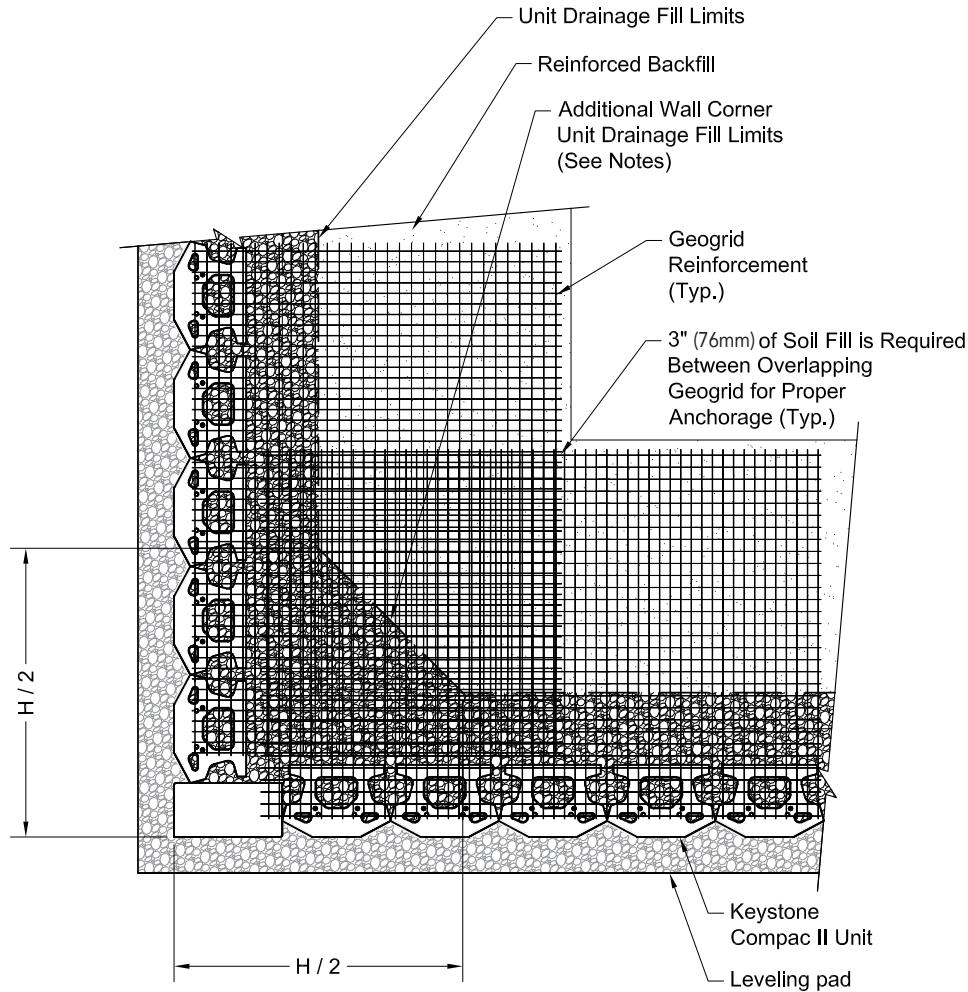
## ISOMETRIC DETAIL



The information contained herein has been compiled by Keystone Retaining Wall Systems® LLC and to the best of our knowledge, accurately represents the Keystone product use in the applications which are illustrated. Final determination of the suitability for the use contemplated and its manner of use are the sole responsibility of the user. Structural design and analysis shall be performed by a qualified engineer.

# 90° Outside Corner : Near Vertical Setback

FIGURE C:3 - TYPICAL GEOGRID INSTALLATION FOR OUTSIDE CORNERS



**Notes:**

Place additional unit drainage fill at outside wall corners to extend back from wall face each way a distance equal to the wall height / 2 ( $H / 2$ ).

Drainage zone and backfill materials should be placed compacted and up to the geogrid elevation and Keystone unit pins should be in place prior to geogrid installation.

Measure, cut and orient the geogrid, as per the engineer's design and/or the geogrid manufacturer's specifications in the correct strength direction.

Hook the geogrid over the Keystone unit pins and tension the geogrid by pulling it back away from the wall. Place a stake through the geogrid at the back to tension the geogrid in place.

Proceed with placement of additional Keystone units, unit drainage fill. Start backfilling nearest the Keystone units and then move back away from the wall, placing backfill materials over the geogrid. After the backfilling process, the tension stakes may be removed for reuse.

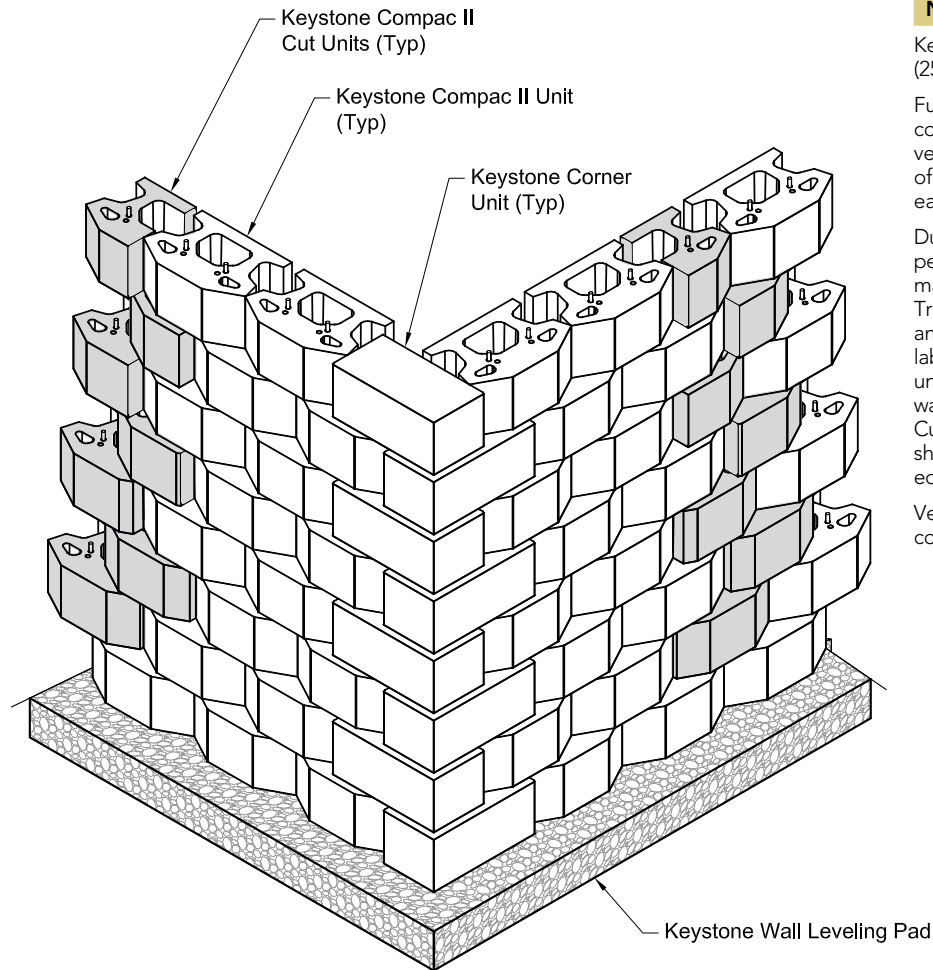
Compact the backfill materials in 8 inch (203mm) lifts to the next reinforcement elevation, and repeat.

The information contained herein has been compiled by Keystone Retaining Wall Systems® LLC and to the best of our knowledge, accurately represents the Keystone product use in the applications which are illustrated. Final determination of the suitability for the use contemplated and its manner of use are the sole responsibility of the user. Structural design and analysis shall be performed by a qualified engineer.

## 90° Outside Corner : Keystone Compac Unit

When constructing a battered wall there are construction issues at the corner as the wall rises vertically. Because the wall is set back, it creates a need to trim structural units on both sides of the corner to maintain a proper running bond pattern in the straight sections of the wall. Keystone has developed a sketch to show proper location for trim units. This illustration is based on a full running bond pattern on the base course, with no trimmed units. (In the case of two corners near each other, it is best to set each corner unit base first to establish corner location, and then set the base course of structural units running to the corners and trim units as necessary.)

FIGURE C:4 - BATTERED SETBACK AT 90° OUTSIDE CORNER



### Notes:

Keystone Compac II units shown in 1" (25mm) setback position.

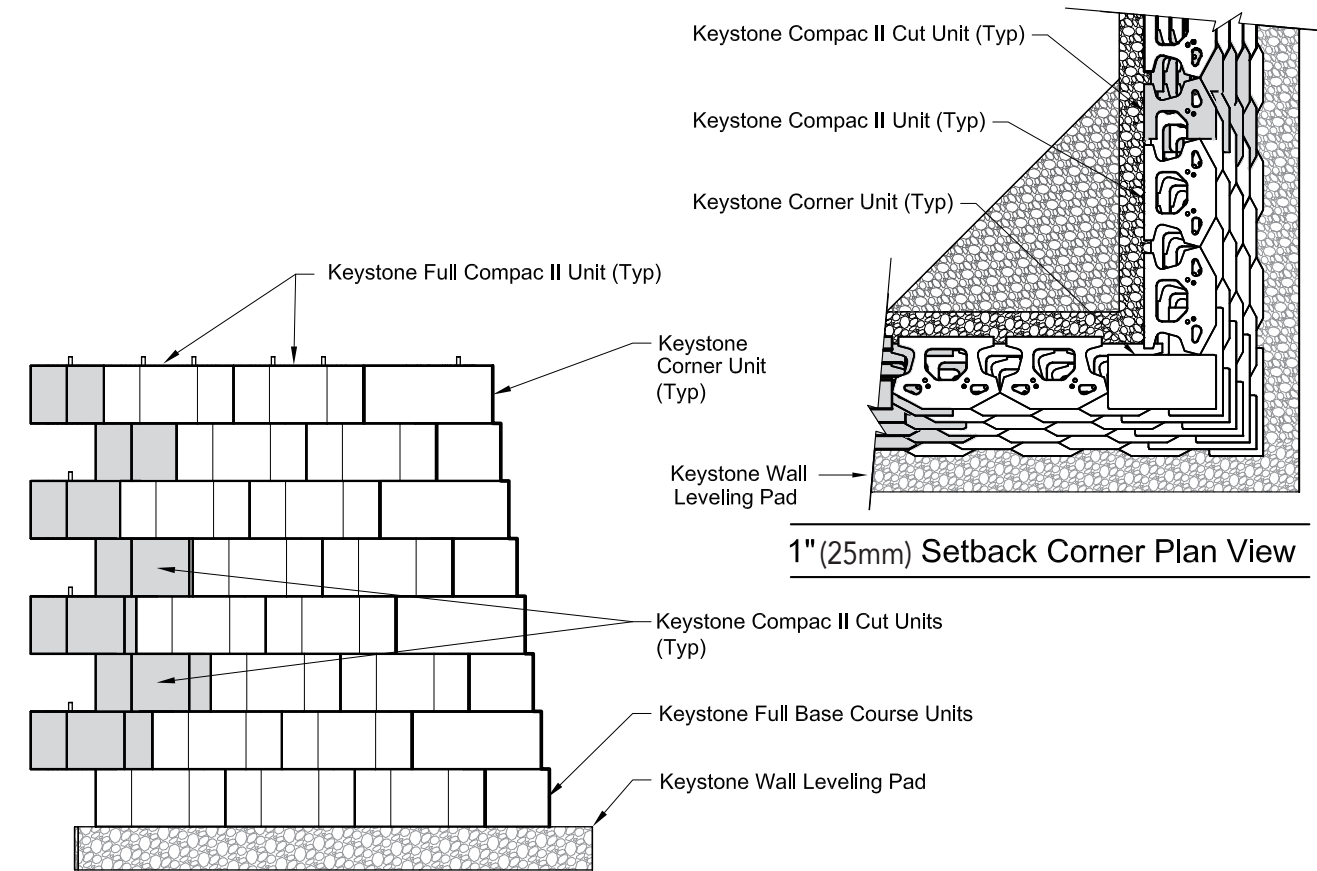
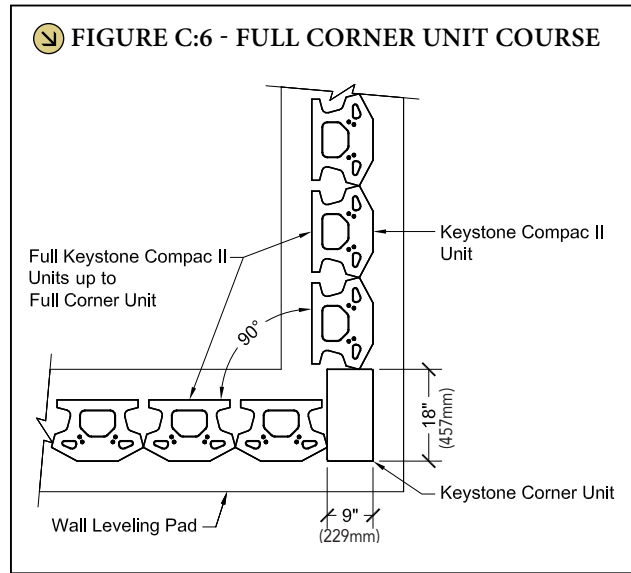
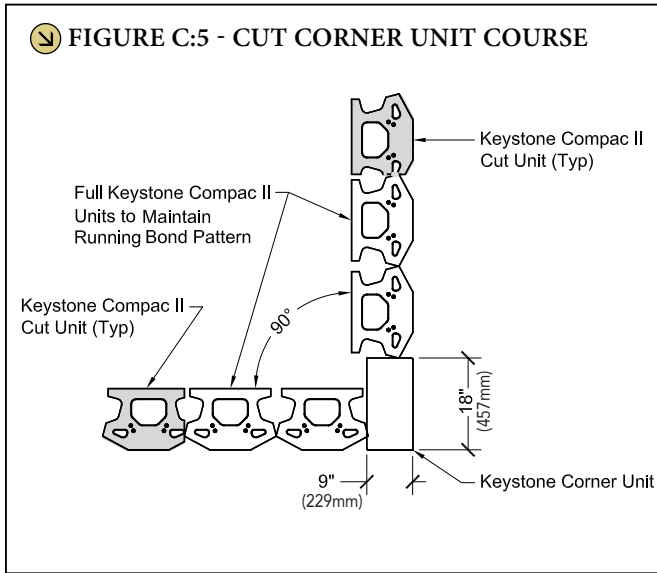
Full uncut units to be used for the base course and as indicated in the details, vertically up the wall corner. A minimum of 2 full units should be placed adjacent to each corner unit.

Due to corner perpendicular wall setback per course, trimming units is necessary to maintain running bond course alignment. Trim block units a minimum 1 corner unit and 2 full units from the corner roughly labeled for cut length and shaded for cut unit designation in both directions from the wall corner for proper wall joint alignment. Cut pieces less than 6" (152mm) in length should not be used. Instead, cut 2 units to equal length.

Verify actual cut lengths as wall is constructed.

1" (25mm) Setback Corner Isometric View

# 90° Outside Corner : 1" Setback



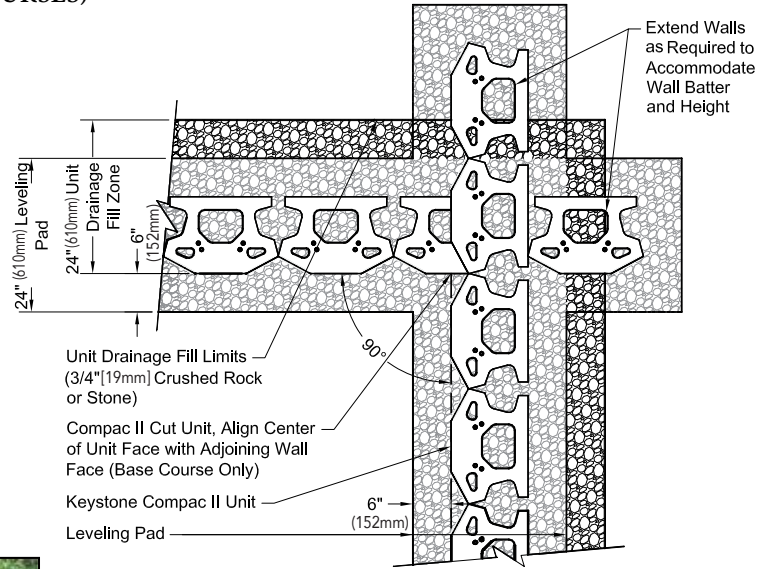
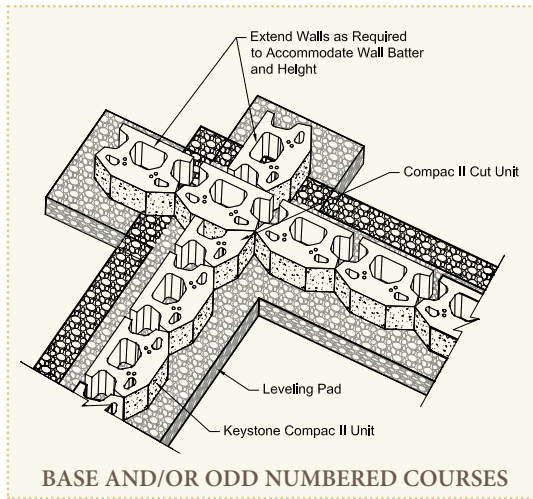
**1" (25mm) Setback Corner Side Elevation View**

The information contained herein has been compiled by Keystone Retaining Wall Systems® LLC and to the best of our knowledge, accurately represents the Keystone product use in the applications which are illustrated. Final determination of the suitability for the use contemplated and its manner of use are the sole responsibility of the user. Structural design and analysis shall be performed by a qualified engineer.

# 90° Inside Corner : Installation Details

The construction of inside corners is relatively simple, because no additional units are required. All you will need is your tape measure, concrete saw, block splitter blade or chisel and a level. There are two ways you can install an inside corner construction; you can butt one wall into the other wall, or you can use the interlocking method as shown below.

FIGURE C:7 - TYPICAL BASE (ODD COURSES)



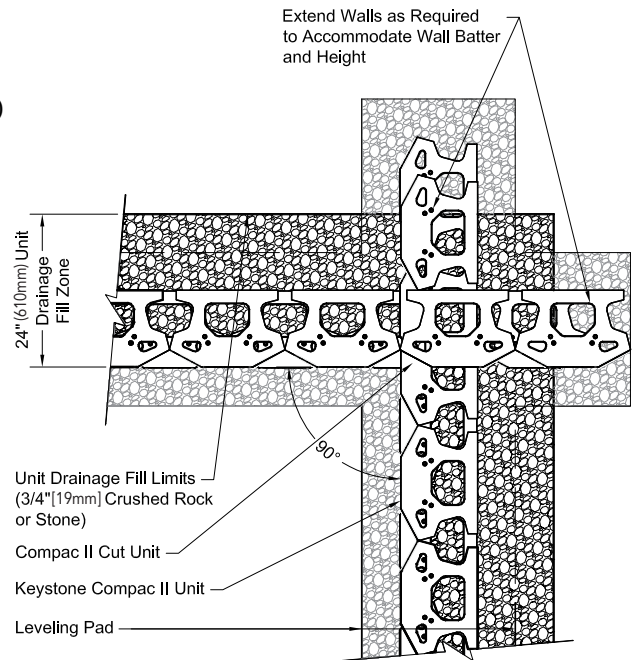
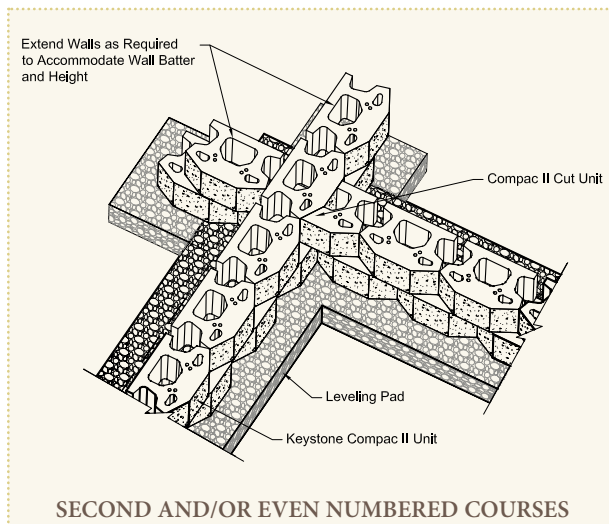
**Notes:**

Add extra full or half units, leveled and aligned beyond the corner in both directions to support the full or partial units to be placed above the current course. These units should project a minimum of 1/2 unit (9" [229mm]) beyond the block of the adjacent row.

Due to corner perpendicular wall setback per course, to maintain running bond course alignment, cut the adjoining unit to the perpendicular wall face labeled "Compac II Cut Unit" as needed in both directions for proper wall joint alignment.



FIGURE C:8 - TYPICAL SECOND (EVEN COURSES)



The information contained herein has been compiled by Keystone Retaining Wall Systems® LLC and to the best of our knowledge, accurately represents the Keystone product use in the applications which are illustrated. Final determination of the suitability for the use contemplated and its manner of use are the sole responsibility of the user. Structural design and analysis shall be performed by a qualified engineer.

# 90° Inside Corner : Installation Details

FIGURE C:9 - TYPICAL GEOGRID INSTALLATION FOR INSIDE CORNERS

**Notes:**

Drainage zone and backfill materials should be placed compacted and up to the geogrid elevation and Keystone unit pins should be in place prior to geogrid installation.

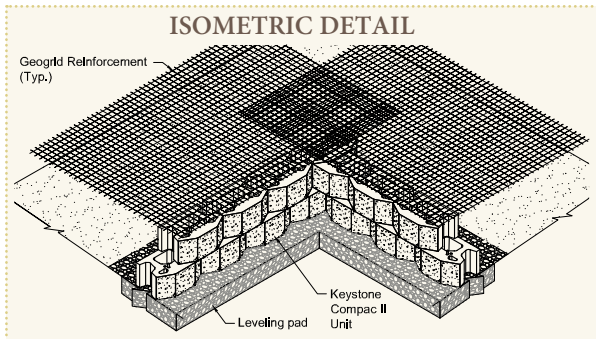
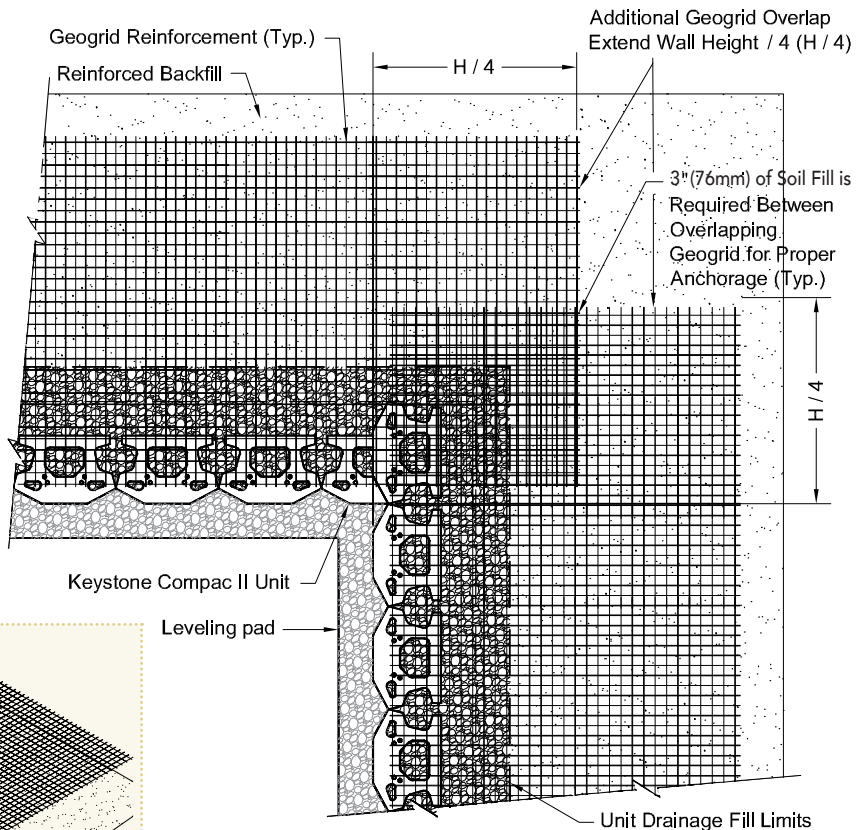
Measure, cut and orient the geogrid, as per the engineers design and the geogrid manufacturer's specifications on correct strength direction.

Place the geogrid over the Keystone unit pins and tension the geogrid by pulling it back away from the wall. Place a stake through the geogrid at the back to tension the geogrid in place.

Proceed with placement of additional Keystone units, then drainage zone and backfill material. Starting at the wall and moving back away from the wall, place the drainage zone and backfill materials over the geogrid to hold the geogrid in place under tension. After the backfilling process, the tension stakes may be removed for reuse.

Then backfill materials up to the next wall elevation where a geogrid is to be place.

Extend geogrid the wall height / 4 (H / 4) beyond the adjoining wall face at inside wall corners.

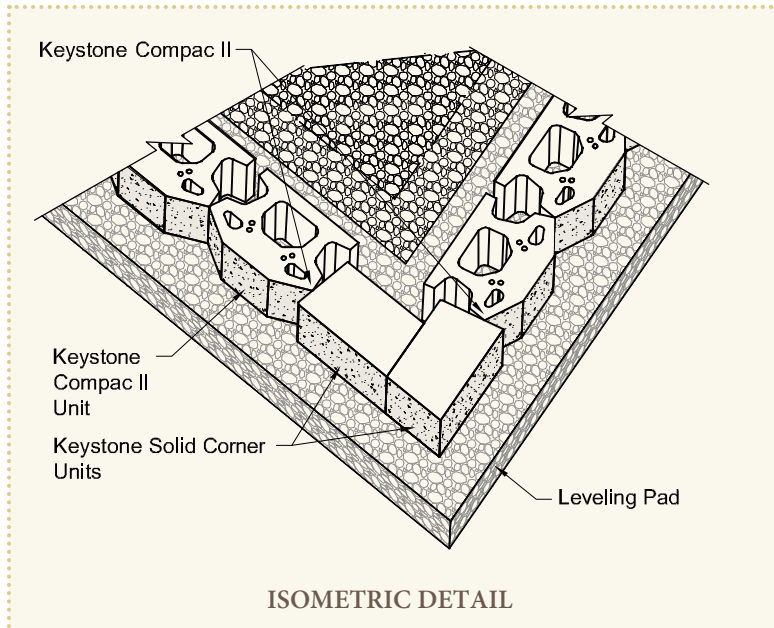
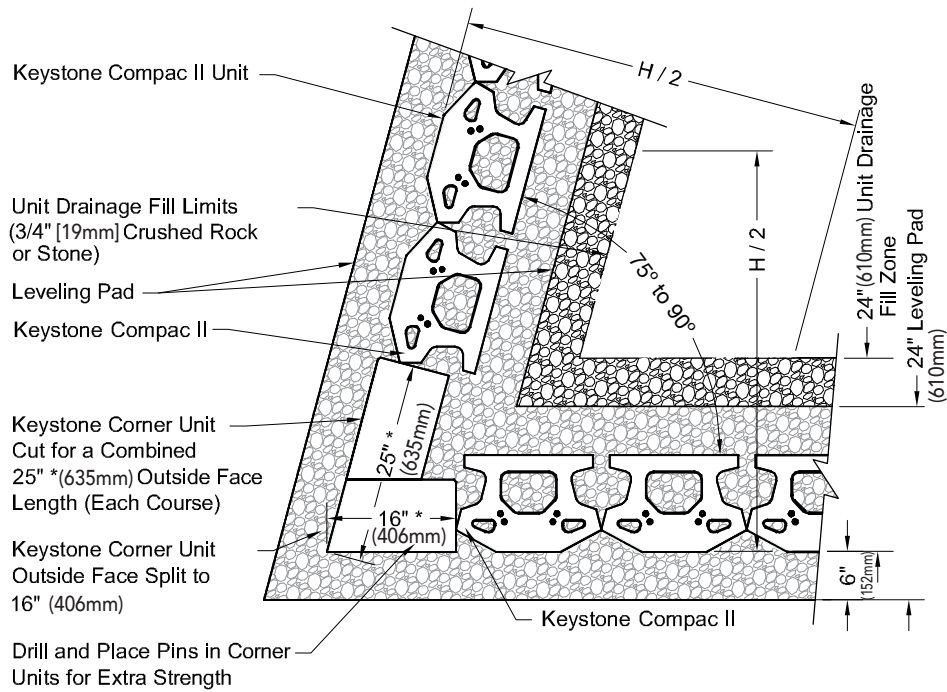


The information contained herein has been compiled by Keystone Retaining Wall Systems® LLC and to the best of our knowledge, accurately represents the Keystone product use in the applications which are illustrated. Final determination of the suitability for the use contemplated and its manner of use are the sole responsibility of the user. Structural design and analysis shall be performed by a qualified engineer.

# Acute Corner : Installation Details

In special cases, an acute corner construction is needed. No special units are necessary for the construction of acute corners; you will just need to field split or cut the corner units. All you will need is your tape measure, concrete saw, splitter blade or chisel and a level. The following is the recommended installation procedure for acute corners.

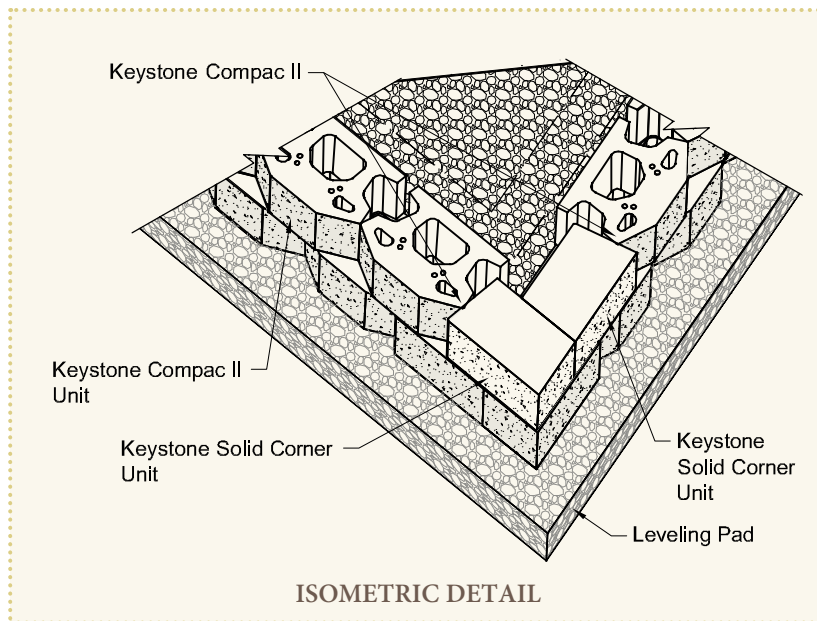
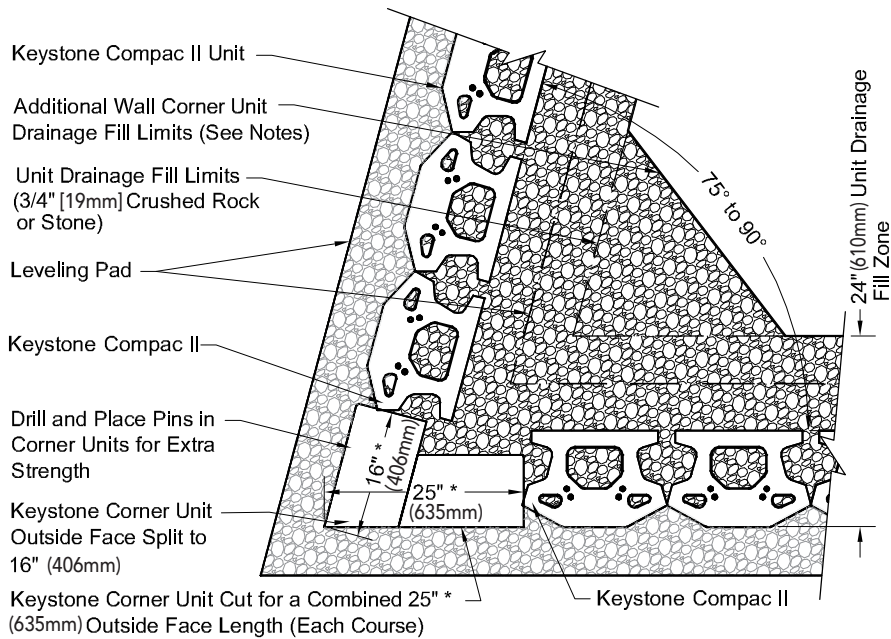
FIGURE C:10 - TYPICAL BASE (ODD COURSES)



The information contained herein has been compiled by Keystone Retaining Wall Systems® LLC and to the best of our knowledge, accurately represents the Keystone product use in the applications which are illustrated. Final determination of the suitability for the use contemplated and its manner of use are the sole responsibility of the user. Structural design and analysis shall be performed by a qualified engineer.



FIGURE C:11 - TYPICAL SECOND (EVEN COURSES)



**Notes:**

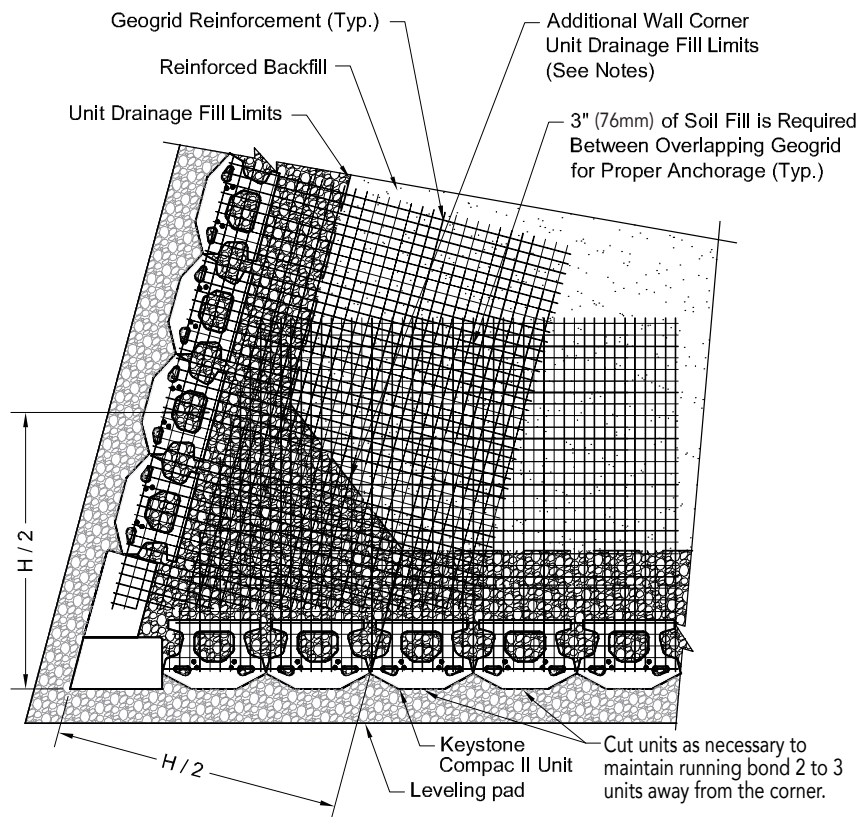
Cut corner piece units to be used for each odd or even course vertically up the wall corner. Corner units to be cut the same for each alternating odd or even course.

Additional crushed rock or stone drainage fill at outside wall corners to extend back from wall face each way at wall height / 2 (H / 2.).

\* Distance varies as angle increases.

# Acute Corner : Installation Details

FIGURE C:12 - TYPICAL GEOGRID INSTALLATION FOR OUTSIDE ACUTE CORNERS



**Notes:**

Unit drainage fill and backfill materials should be placed compacted to the geogrid elevation and Keystone unit pins should be in place prior to geogrid installation.

Place additional unit drainage fill at acute wall corner to extend back from wall face, each way, a distance equal to the wall height / 2 ( $H / 2$ ).

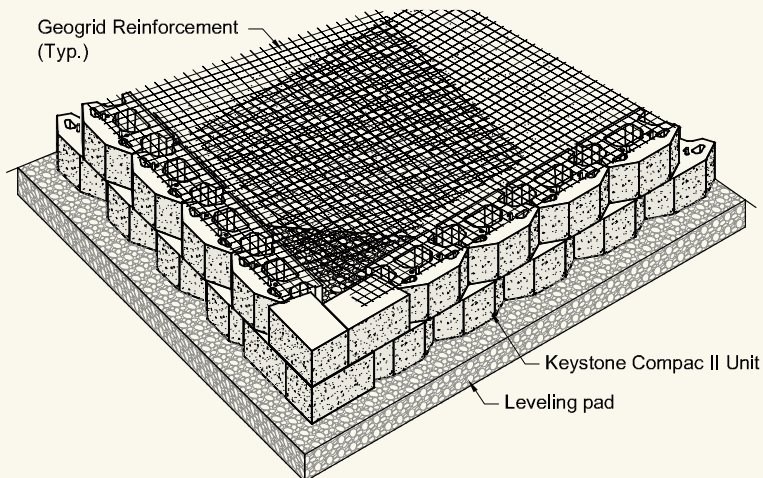
Measure, cut and orient the geogrid, as per the engineer's design and/or the geogrid manufacturer's specifications in the correct strength direction.

Place the geogrid over the Keystone unit pins, place an additional course of units and tension the geogrid by pulling it back away from the wall. Place a stake through the geogrid at the back to tension the geogrid in place.

Proceed with placement of additional Keystone units, unit drainage fill and backfill material. Start backfilling nearest the Keystone units and then move back away from the wall, placing backfill materials over the geogrid to hold the geogrid in place under tension. After the backfilling process, the tension stakes may be removed for reuse.

Compact the backfill materials in 8 inch (203mm) lifts to the next reinforcement elevation, and repeat.

**ISOMETRIC DETAIL**



The information contained herein has been compiled by Keystone Retaining Wall Systems® LLC and to the best of our knowledge, accurately represents the Keystone product use in the applications which are illustrated. Final determination of the suitability for the use contemplated and its manner of use are the sole responsibility of the user. Structural design and analysis shall be performed by a qualified engineer.

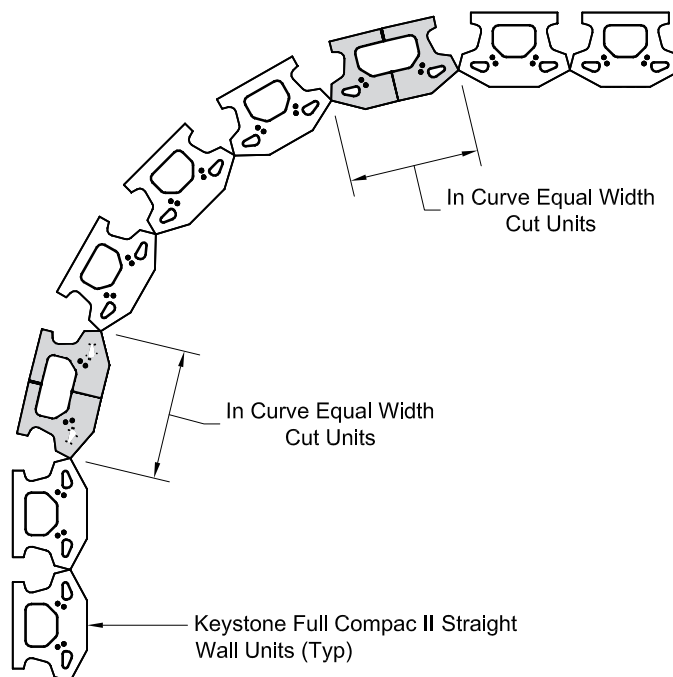
Inside curves for moderately tall Keystone walls are more difficult to construct than a straight wall due to the complex geometry resulting from a battered wall face in a curve. Inside curves allow good access for compaction and the wall face units tend to support each other like an arch when the soil strain associated with the active earth pressure condition develops.

As the wall gets taller, inside curves will result in the top of the wall becoming longer than the base. For wall systems to maintain the desired running bond configuration, gaps between units tend to form. The gapping is less significant for a wall in the near vertical pin position ( $<1^\circ$ ) than it is for a battered wall ( $8^\circ$ ).

The following is an outline to a process of constructing inside curves in taller battered walls while helping to maintain the integrity of Keystone's pin connection system and running bond. See the illustration below and on the next page.

1. Creating filler pieces will be necessary. For example, if a course can be built with pins being contained in the pin receiving holes and a 2" (51mm) gap is created, leave the gap and one adjacent unit out of the wall, cut two blocks 10" (254mm) wide ( $2" [51\text{mm}] + 18" [457\text{mm}] = 20" [508\text{mm}]$ ),  $20" [508\text{mm}] / 2 \text{ block} = 10" [254\text{mm}]$  each) and place the two 10" (254mm) cut blocks adjacent to each other in the wall. Cut wall units should not be less than 6" (152mm) in length. All cut pieces should be glued in place.
2. Eventually an entire unit fills the gap and the process is repeated.

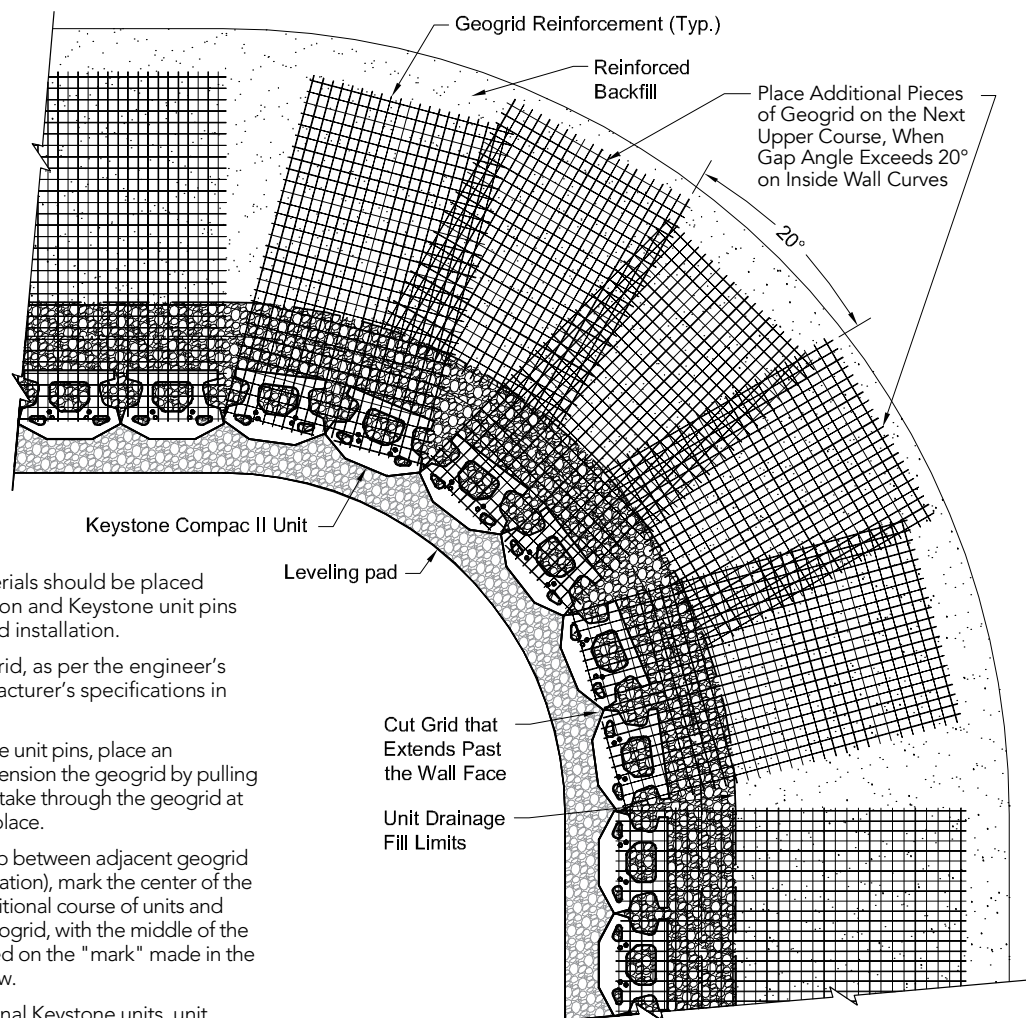
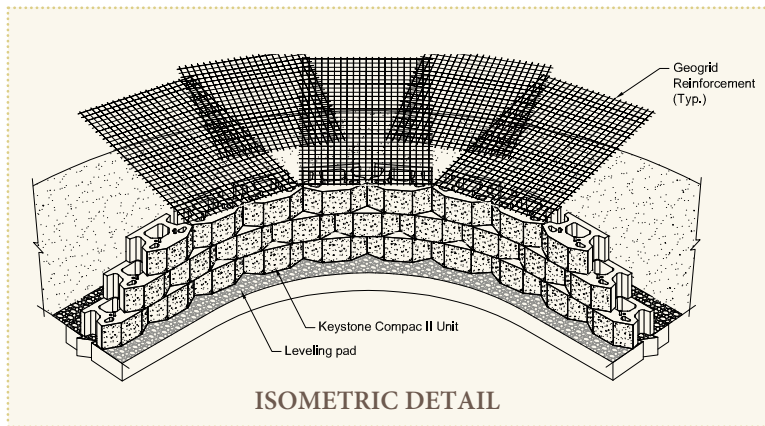
📌 FIGURE C:13 - IN CURVE CUT UNITS EXAMPLE COURSE



In Curve Cut Units Example Course

# Concave Curves : Installation

FIGURE C:14 - CONCAVE CURVE GEOGRID INSTALLATION



**Notes:**

Unit drainage fill and backfill materials should be placed compacted to the geogrid elevation and Keystone unit pins should be in place prior to geogrid installation.

Measure, cut and orient the geogrid, as per the engineer's design and/or the geogrid manufacturer's specifications in the correct strength direction.

Place the geogrid over the Keystone unit pins, place an additional course of wall units and tension the geogrid by pulling it back away from the wall. Place a stake through the geogrid at the back to tension the geogrid in place.

If the radius of the wall creates a gap between adjacent geogrid layers of greater than 20° (see illustration), mark the center of the "gap" in the geogrid, place an additional course of units and then place an additional layer of geogrid, with the middle of the additional piece of geogrid centered on the "mark" made in the center of the gapped geogrid below.

Proceed with placement of additional Keystone units, unit drainage fill and backfill material. Start backfilling nearest the Keystone units and then move back away from the wall, placing backfill materials over the geogrid to hold the geogrid in place under tension. After the backfilling process, the tension stakes may be removed for reuse.

Compact the backfill materials in 8 inch (203mm) lifts to the next reinforcement elevation, and repeat.

The information contained herein has been compiled by Keystone Retaining Wall Systems® LLC and to the best of our knowledge, accurately represents the Keystone product use in the applications which are illustrated. Final determination of the suitability for the use contemplated and its manner of use are the sole responsibility of the user. Structural design and analysis shall be performed by a qualified engineer.

# Convex Curves: Introduction

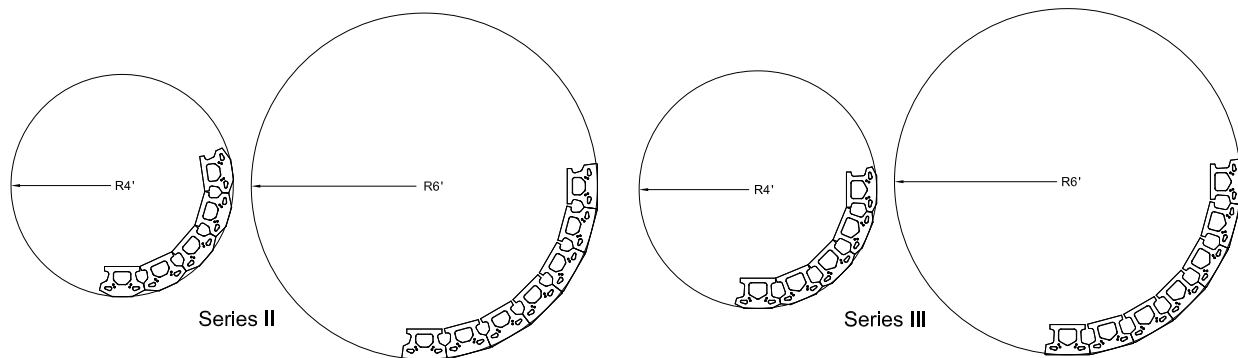
Convex curves are an aesthetically pleasing accent to any retaining wall. Keystone units can be easily integrated with multiple curves within the same wall. However, convex curves require attention to the details during construction. Every wall system has a minimum radius that can be built before the tails of the units come into contact with each other. This minimum radius is unique to the shape of each individual block system. In convex curves with wall batter, the tightest radius will always be the top course of the wall. This means that the radius at the base course of a convex curve wall will be larger than the desired radius at the top of the wall. Care should be taken when laying out a wall horizontal location in the field given these wall batter and radius relationships. The following is a minimum radius table for Keystone Compac and Keystone Standard units.

Minimum Radius Table			
Unit Type	Series	Face Style	
		Tri-plane	Straight Split
Keystone Compac II & III	II	4' (1.2m)	6' (1.8m)
	III	4' (1.2m)	6' (1.8m)
Keystone Standard (18" [457mm] deep)	I	5' (1.5m)	6' (1.8m)
	II	6' (1.8m)	8' (2.4m)
	III	5' (1.5m)	6' (1.8m)
Keystone Standard (21" [533mm] deep)	I	5' (1.5m)	6' (1.8m)
	III	5' (1.5m)	6' (1.8m)

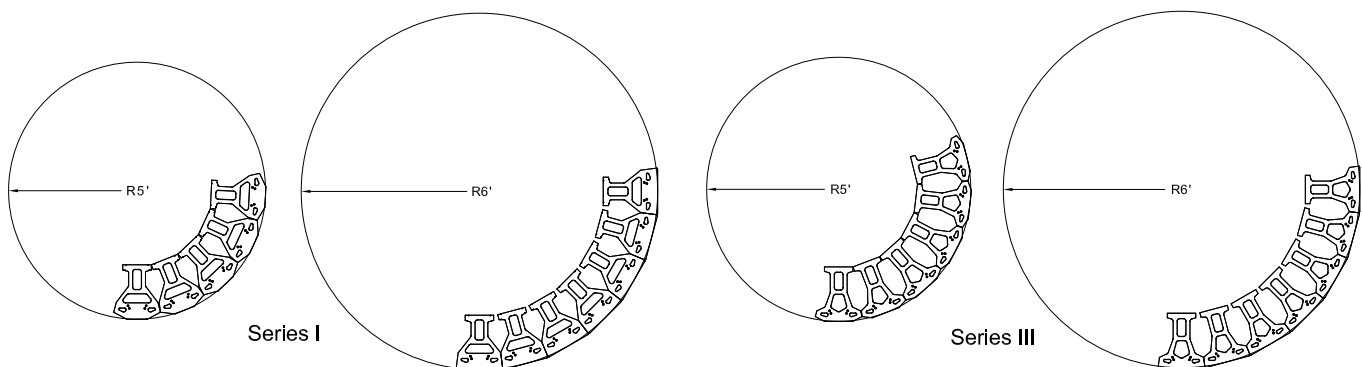
**Notes:**

- 1) The table shows the minimum radius the units can turn without trimming.
- 2) Minimum radius was determined as being able to complete a full circle with units.
- 3) Quarter circle diagrams are shown below.
- 4) Minimum radius is for one course of units / or at top of wall. Radius at the base of the wall will need to be larger to account for wall batter.

FIGURE C:15 - MINIMUM RADIUS - KEYSTONE COMPAC UNITS



Keystone Compac Units Minimum Radius Examples



Keystone Standard Units (21" [533mm] Deep) Minimum Radius Examples

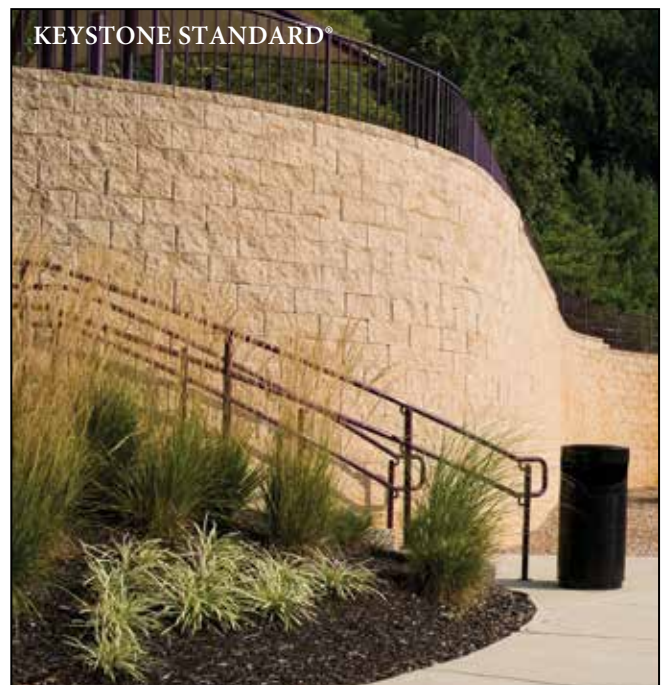
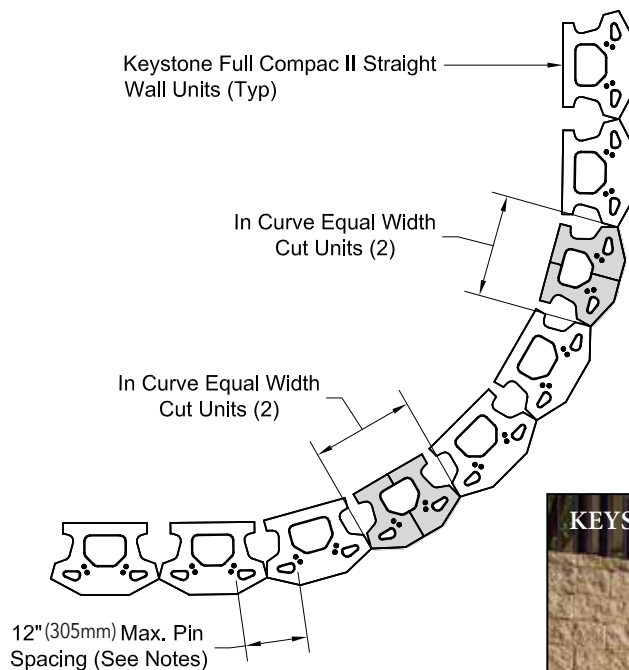
The information contained herein has been compiled by Keystone Retaining Wall Systems® LLC and to the best of our knowledge, accurately represents the Keystone product use in the applications which are illustrated. Final determination of the suitability for the use contemplated and its manner of use are the sole responsibility of the user. Structural design and analysis shall be performed by a qualified engineer.

## Convex Curves: With Setback

A setback battered convex curve wall requires some trimming of the units. When constructing an outside curve with batter, we recommend performing the following steps to maintain pin integrity and running bond configuration. It is recommended to construct the wall into the curve, maintaining a running bond pattern in the straight sections of the wall on either side of the curve. See Figure C:16 for additional details.

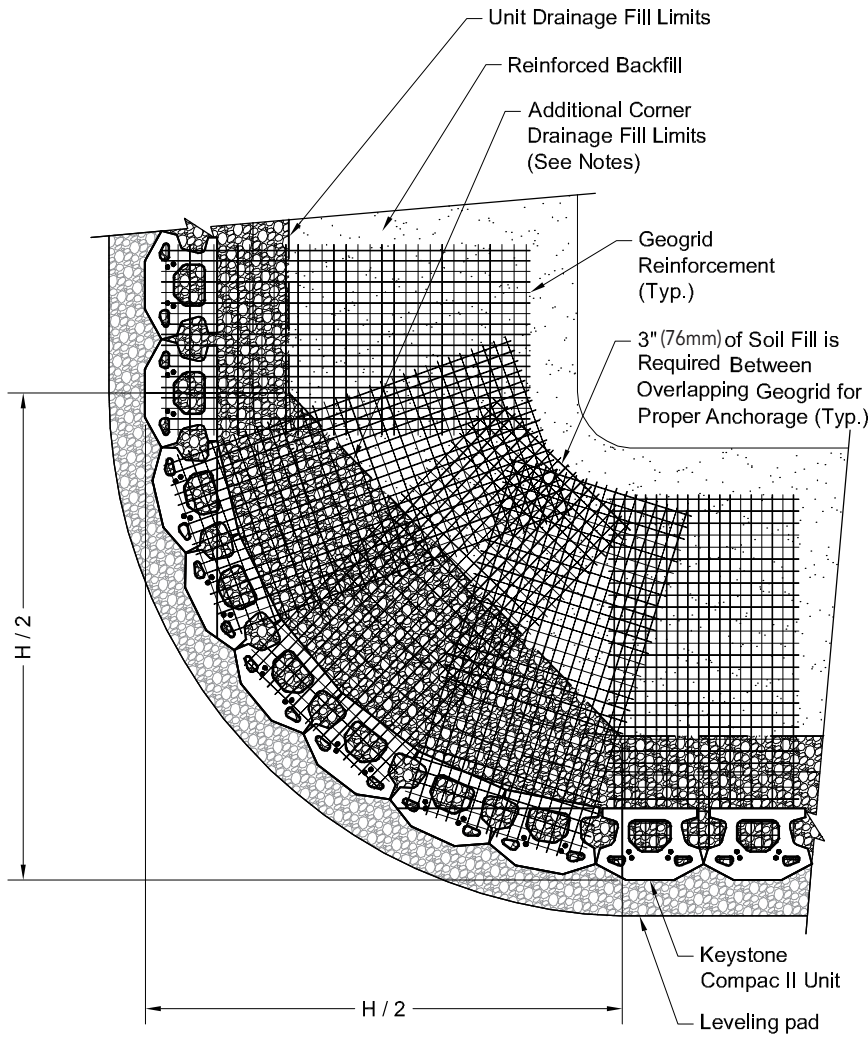
When building a battered wall in a convex or outside radius curve, the radius of the upper courses will become less than the radius of each lower course due to wall batter or setback. This will cause the units in upper courses to run off bond and the pins to migrate to the edge of the pin receiving hole. When this occurs, it will be necessary to cut a block the required amount to cause the pin on the next adjacent block to be at the opposite side of the pin receiving hole as the block on the other side of the cut. When coming out of the radius, cutting of another block may be required to maintain a more precise running bond on the straight wall extending away from the curve.

FIGURE C:16 - IN CURVE CUT UNITS EXAMPLE COURSE



The information contained herein has been compiled by Keystone Retaining Wall Systems® LLC and to the best of our knowledge, accurately represents the Keystone product use in the applications which are illustrated. Final determination of the suitability for the use contemplated and its manner of use are the sole responsibility of the user. Structural design and analysis shall be performed by a qualified engineer.

FIGURE C:17 - CONVEX CURVE GEOGRID INSTALLATION



**Notes:**

Unit drainage fill and backfill materials should be placed compacted to the geogrid elevation and Keystone unit pins should be in place prior to geogrid installation.

Place additional unit drainage fill at outside wall curve to extend back from wall face each way a distance equal to the wall height / 2 (H / 2).

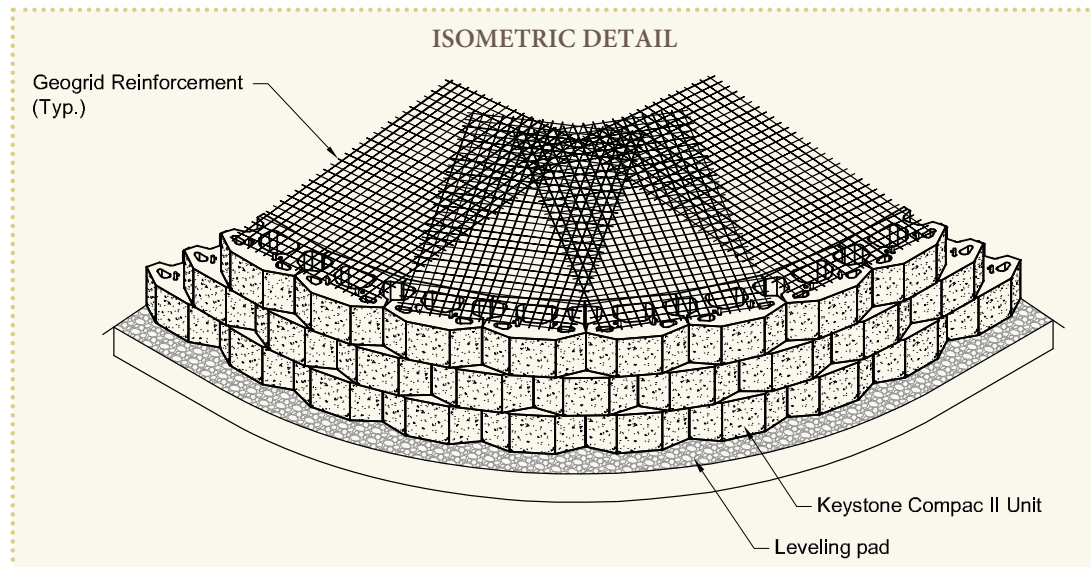
Measure, cut and orient the geogrid, as per the engineer's design and/or the geogrid manufacturer's specifications in the correct strength direction.

Place the geogrid over the Keystone unit pins, place an additional course of units and tension the geogrid by pulling it back away from the wall. Place a stake through the geogrid at the back to tension the geogrid in place.

Proceed with placement of additional Keystone units, unit drainage fill and backfill material. Start backfilling nearest the Keystone units and then move back away from the wall, placing backfill materials over the geogrid to hold the geogrid in place under tension. After the backfilling process, the tension stakes may be removed for reuse.

Compact the backfill materials in 8 inch lifts to the next reinforcement elevation, and repeat.

**ISOMETRIC DETAIL**



The information contained herein has been compiled by Keystone Retaining Wall Systems® LLC and to the best of our knowledge, accurately represents the Keystone product use in the applications which are illustrated. Final determination of the suitability for the use contemplated and its manner of use are the sole responsibility of the user. Structural design and analysis shall be performed by a qualified engineer.





## SECTION D

# W A L L FINISHING O P T I O N S

A wall is not complete without the perfect finishing touch. The flexibility of the Keystone units creates a variety of wall finishing options. The most common wall finish is to cap the wall with a Keystone cap. Cap options vary by region so check with your local Keystone producer for availability in your area. Keystone units can also be capped with a variety of decorative precast concrete products, or even CIP concrete copings. This section outlines the construction techniques and details for these various options.

Tools and materials that will be required:

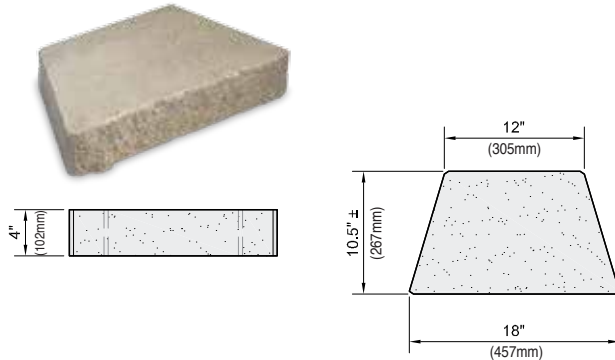
- 12 inch (305mm) and 48 inch (1.2m) levels
- Tape measure
- Personal protective equipment
- Keystone caps
- Landscape finishing material
- Exterior grade concrete adhesive

## Cap Units: Introduction

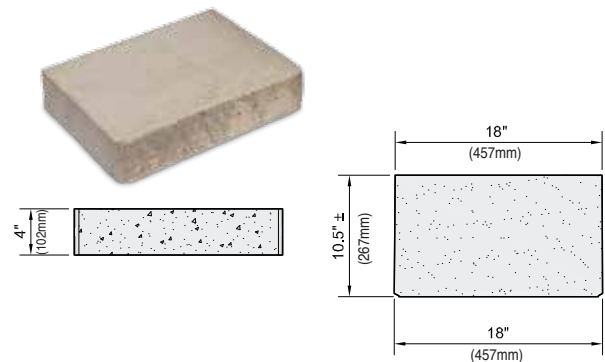
A Keystone retaining wall is not complete until it is finished with the right cap. Keystone offers a selection of cap designs, available in various combinations of facial finish and degrees of angled sides\*. The following information will clearly explain the uses of these units and show a variety of finishing techniques. You may also opt to finish your wall with a precast decorative concrete finishing option. See your local manufacturer for details.

### CAPPING UNITS

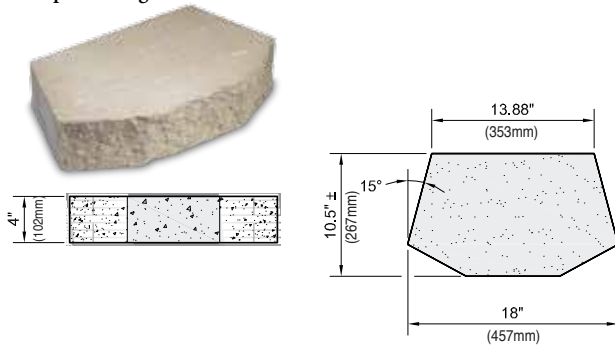
Universal Cap: Finished on both front and back



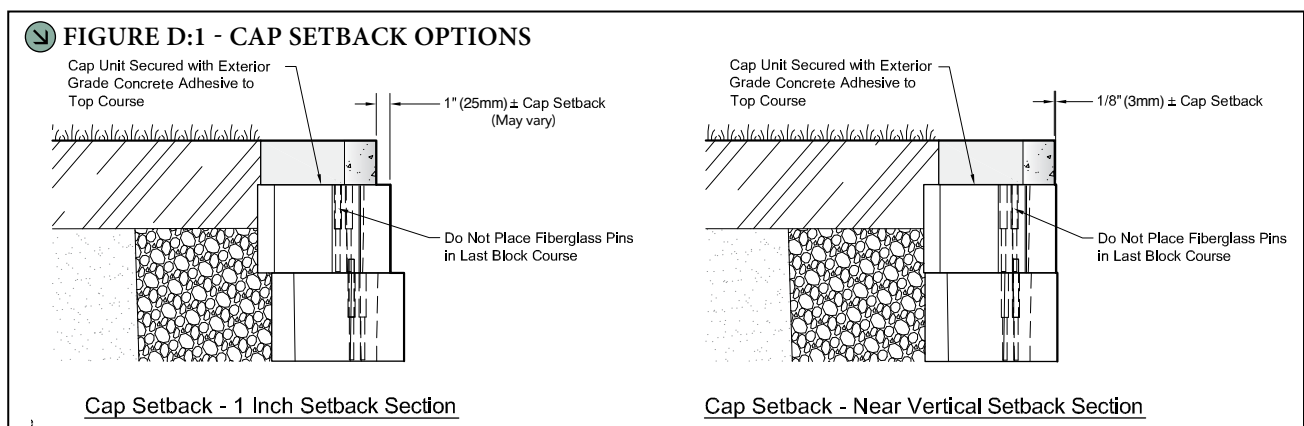
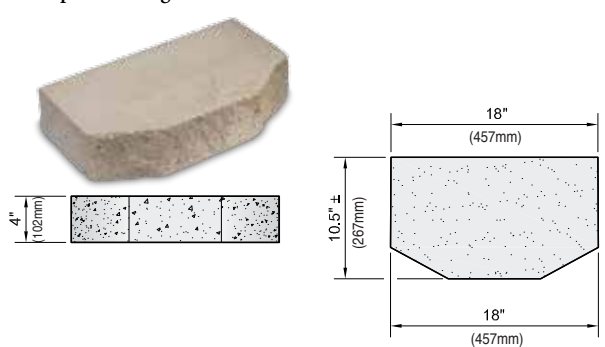
Straight-face: Straight-sided



Tri-plane: Angle-sided



Tri-plane: Straight-sided



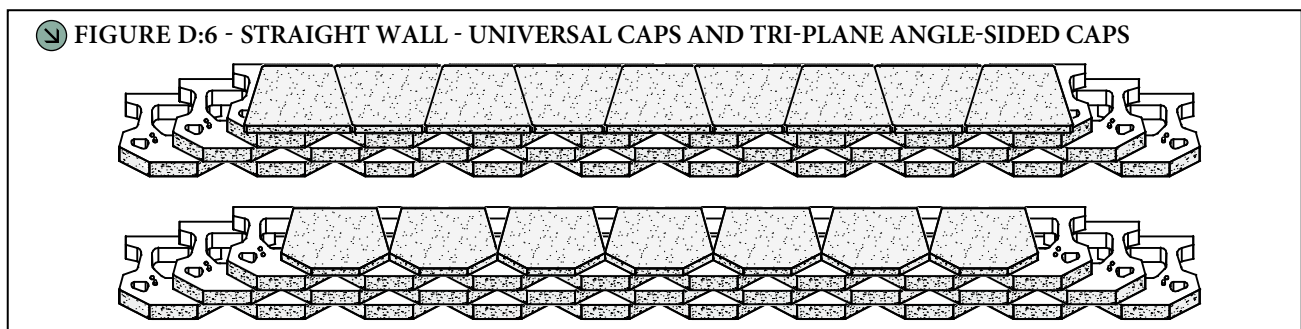
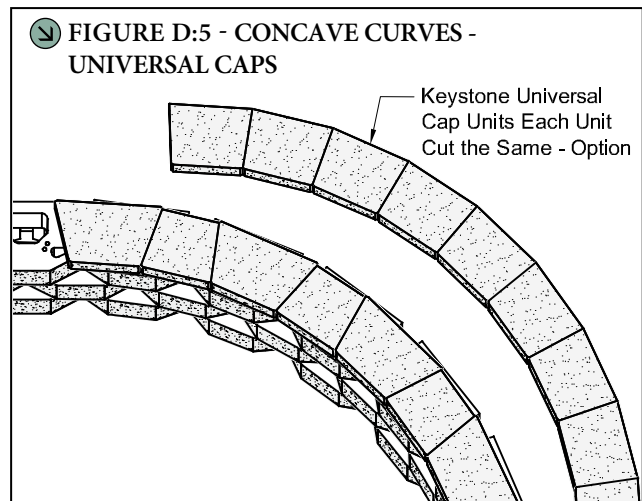
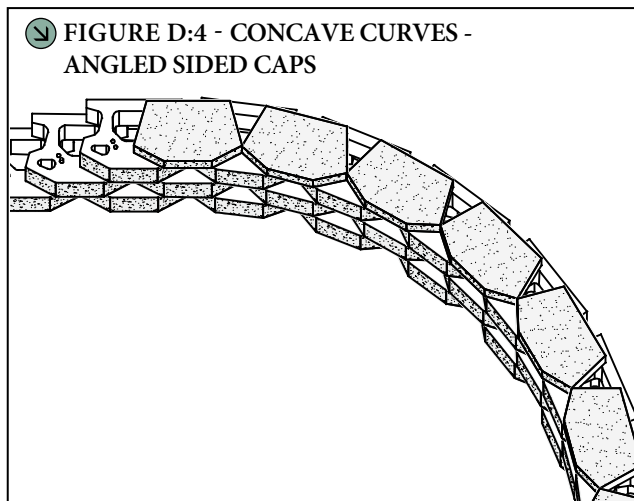
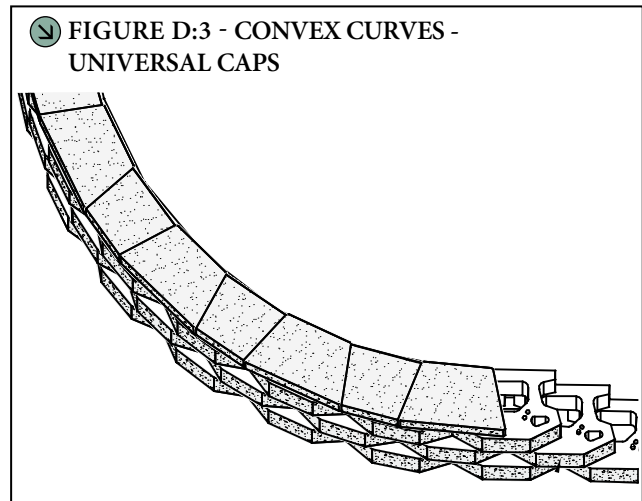
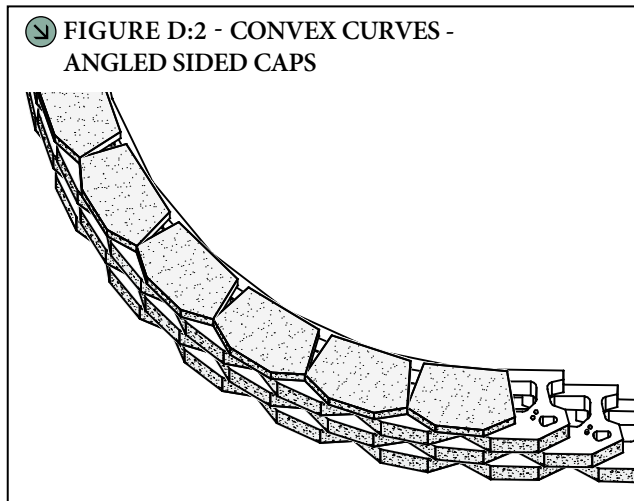
**NOTE:**

\*8" (203mm) capping option not shown. Capping options, weights, dimensions and product designs vary by manufacturer. Contact your local manufacturer for availability. Capping is not required to guarantee structural stability; capping improves the aesthetics of the finished wall.

The information contained herein has been compiled by Keystone Retaining Wall Systems® LLC and to the best of our knowledge, accurately represents the Keystone product use in the applications which are illustrated. Final determination of the suitability for the use contemplated and its manner of use are the sole responsibility of the user. Structural design and analysis shall be performed by a qualified engineer.

Like other Keystone units, all cap units can be used interchangeably. Depending on the wall contour, some cap units will work more effectively than others (i.e. angled side units for concave curves). In any given installation, if binding occurs between units, the units can be modified to fit using a concrete saw, chisel or other device. Make sure to wear proper PPE equipment when splitting or cutting.

Installation of the cap units is a simple one step operation. Sweep the lower units clean and make sure the units are dry; use a construction adhesive on the top surface of the last course before applying cap units. See Figure A:10 (p. 19) for installation instructions. The following illustrations demonstrate common uses of the Keystone cap units.



The information contained herein has been compiled by Keystone Retaining Wall Systems® LLC and to the best of our knowledge, accurately represents the Keystone product use in the applications which are illustrated. Final determination of the suitability for the use contemplated and its manner of use are the sole responsibility of the user. Structural design and analysis shall be performed by a qualified engineer.

## Capping: Installation

The size of each Keystone unit makes this system very adaptable to grade changes. The top of a Keystone wall can be constructed with level top of wall grade or up to 1:1 unit step-downs from the top of the wall. As the wall cap units step up and down grades, an additional installation procedure is required to firmly fix some cap units in position. To prevent showing the side of the wall units at the stepping of a wall, 4 inch (102mm) cap units can be double stacked or one 8 inch cap unit may be placed at each step down or step up location, see Figure A:3 (p. 14). The caps should be attached using a bonding material. Use a flexible epoxy-based adhesive designed to bond concrete or masonry. Refer to manufacturer's instructions for complete details. Apply the adhesive to areas where the units make contact. See Figure A:10 (p. 19) for installation instructions.

FIGURE D:7 - STRAIGHT WALL WITH DOUBLE-STACKED CAP STEP

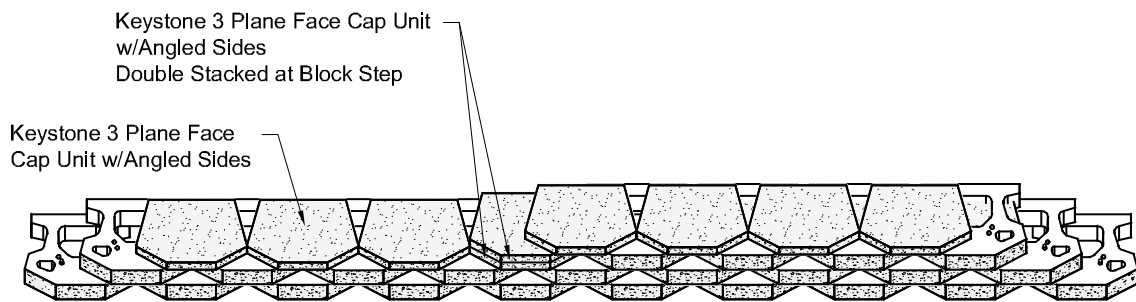
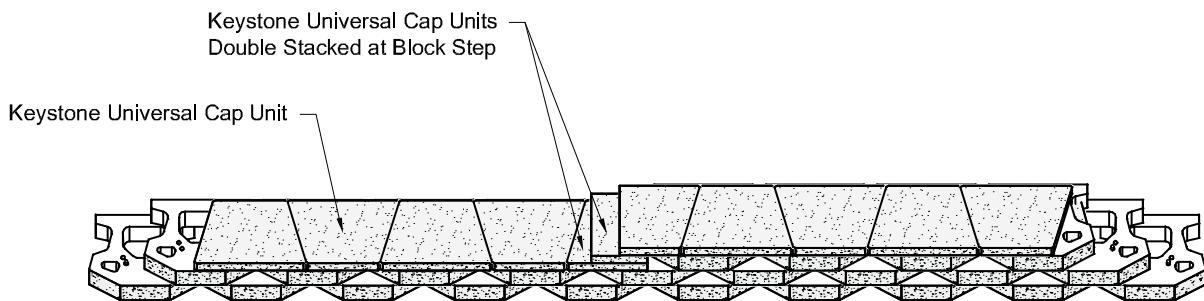


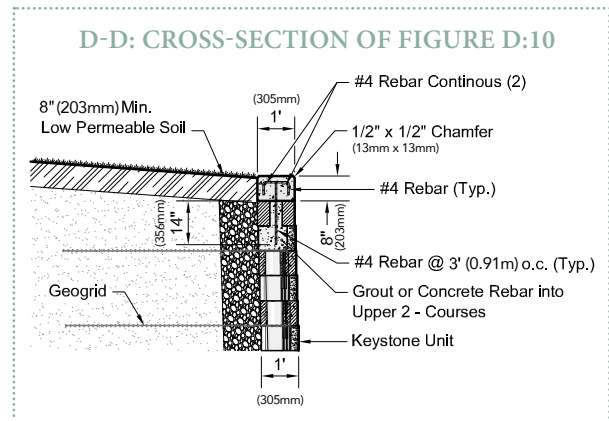
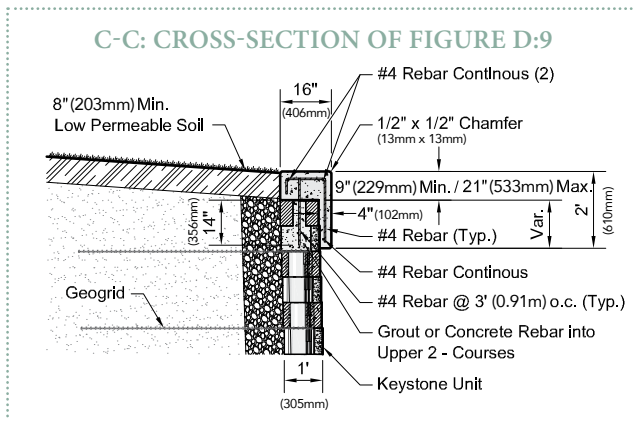
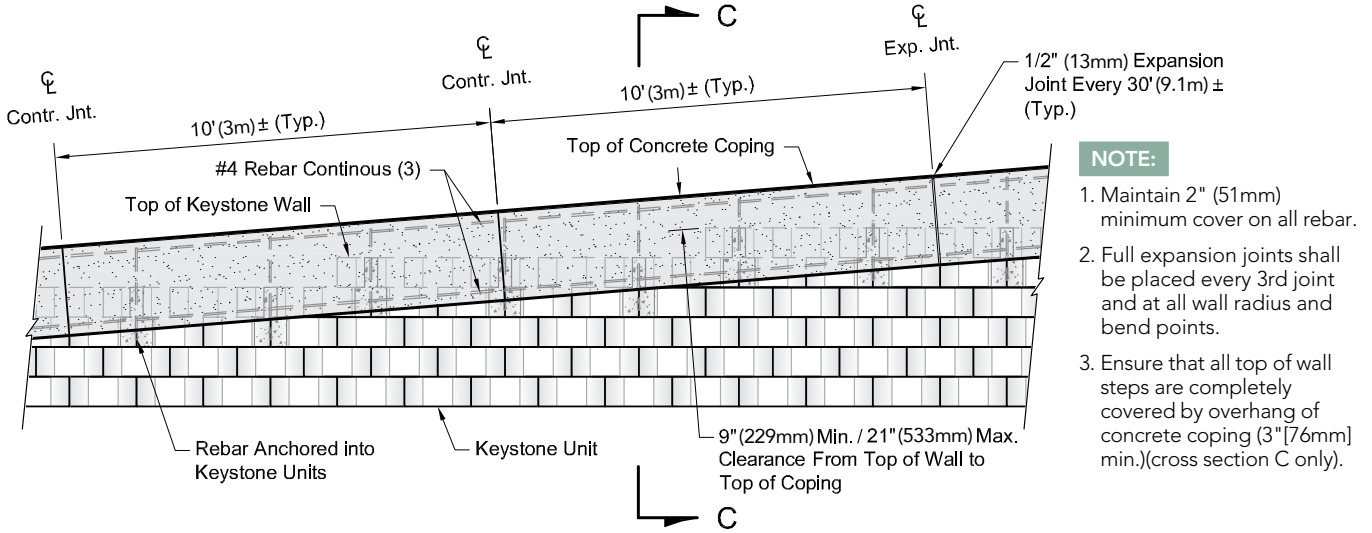
FIGURE D:8 - RANDOM STEPS WITH SPLIT DOUBLE-STACKED UNIVERSAL CAPS



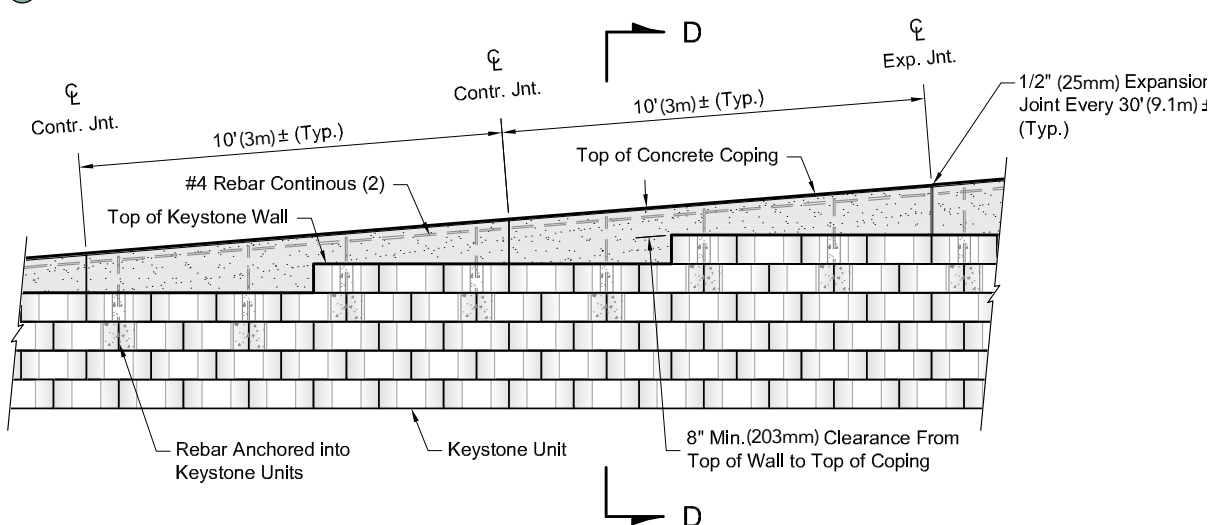
The information contained herein has been compiled by Keystone Retaining Wall Systems® LLC and to the best of our knowledge, accurately represents the Keystone product use in the applications which are illustrated. Final determination of the suitability for the use contemplated and its manner of use are the sole responsibility of the user. Structural design and analysis shall be performed by a qualified engineer.

At times a concrete coping is required for the top of wall finish. The following details are for a typical CIP coping option. These two concrete coping options are installed with proper form work and add an alternate aesthetically pleasing look to the top of the wall that can follow profile grades with the steps.

**FIGURE D:9 - PARTIAL CAST IN PLACE CONCRETE COPING**



**FIGURE D:10 - PARTIAL CAST IN PLACE TOP CONCRETE COPING DETAIL**



The information contained herein has been compiled by Keystone Retaining Wall Systems® LLC and to the best of our knowledge, accurately represents the Keystone product use in the applications which are illustrated. Final determination of the suitability for the use contemplated and its manner of use are the sole responsibility of the user. Structural design and analysis shall be performed by a qualified engineer.



## SECTION E

# SPECIALTY WALL CONSTRUCTION DETAILS

Since its inception in 1986, Keystone has been the segmental retaining wall design leader. This section covers a variety of the most common wall details that may be confronted when constructing a Keystone wall. Some of the details presented in the section have been developed specifically based on industry design standards. Other details have been developed through our years of experience in the segmental retaining wall industry.

Items that are covered in this section:

- Retaining wall drainage
- Water applications
- Barriers
- Fencing
- Parapets
- Steps and stairs
- Terraced and wall applications
- Wall repair
- Tree planting guidelines
- Creative options

# Retaining Wall Drainage Options

Poor drainage is a leading cause of retaining wall performance issues. Hydrostatic pressure can accumulate behind a wall and add an increased load on the wall if drainage provisions are not installed or not adequate for the conditions. The Keystone system has superior drainage features. The techniques below should be considered where the specified drainage issues are present.

## 1. Basic drainage/Unit drainage fill

Keystone's mortarless, interlocking system, with a free draining gravel drainage zone and corefill. See the figure below, notes 1 and 4. This will allow proper drainage under most circumstances. Drain tiles should be routed to a storm drainage system or daylighted below or through the wall at every low point and at 50 to 75 feet (15.2 - 22.9m) on center.

## 2. Surface run-off

Divert surface drainage at the top of the retaining wall by placing a impermeable soil cap (i.e. clay) or formed swale (i.e. soil or concrete) along the back surface of the Keystone units. This will help direct run-off away from the retaining wall.

## 3. Embankment flow

When embankment ground water flow behind the wall is likely, place a drainage composite or chimney drain over the cut soil (see product suppliers for recommended coverage and installation instructions or drainage composite). The drainage composite or chimney drain should drain to an outflow pipe (i.e. drain tile) to remove water. Numerous cost-effective products are available to serve this purpose.

## 4. Ground water flow

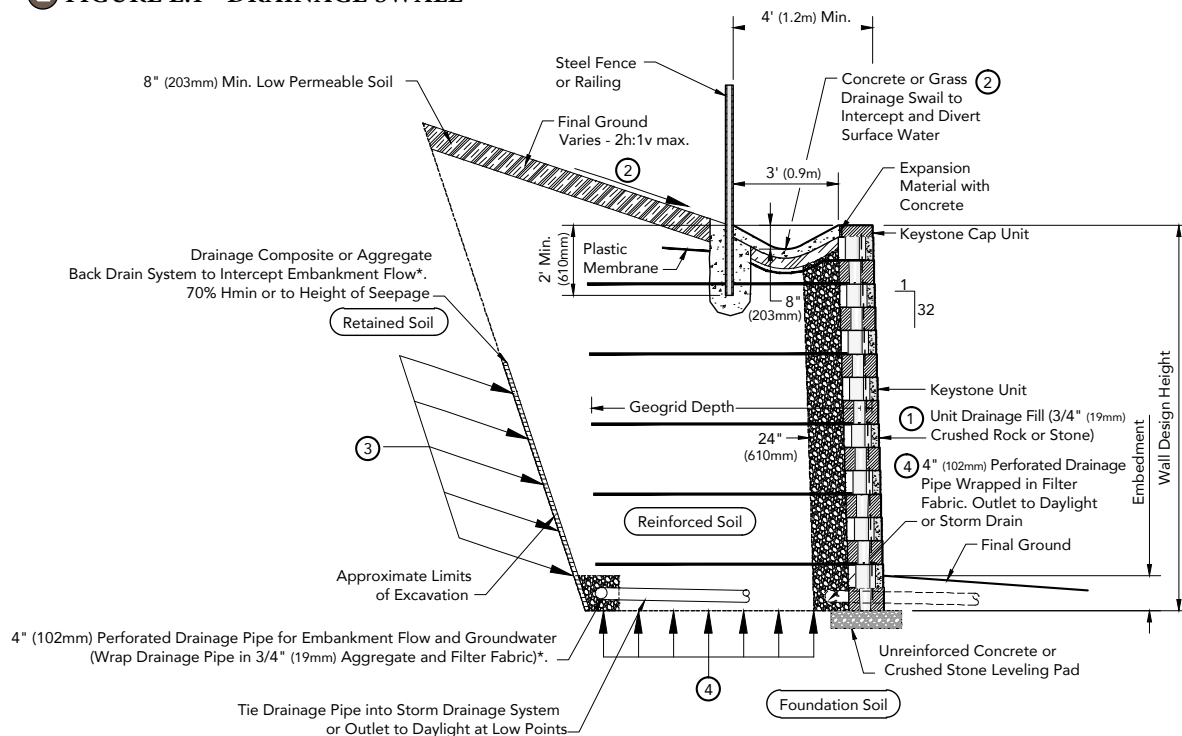
The effects of seasonally fluctuating ground water, at the base of the retaining wall, can be offset by placing an outflow pipe (i.e. drain tile) behind the lowest unit, along with a drain behind the reinforced fill.

### GENERAL NOTES:

Rear drainage pipe should be included when:

- » Groundwater or seepage is present in retained soils.
- » Springs or seasonal seepage potential is noted in geotechnical report.
- » Reinforced soil of lower permeability than retained soils.
- » Generally, additional drainage material such as aggregate drains and fabrics and/or drainage composite nets are used in conjunction with rear drainage pipe as directed.
- » When above conditions are not present or groundwater conditions are not a factor, the rear drainage pipe may be omitted or alternately located behind units at the base of the drainage fill.

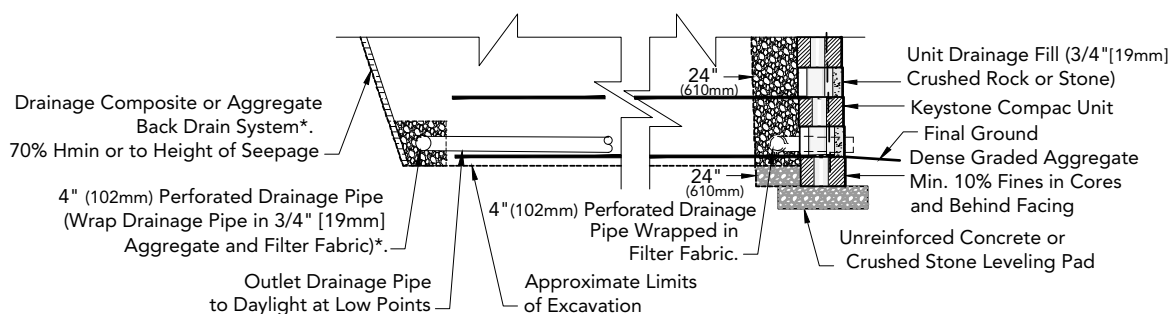
FIGURE E:1 - DRAINAGE SWALE



The information contained herein has been compiled by Keystone Retaining Wall Systems® LLC and to the best of our knowledge, accurately represents the Keystone product use in the applications which are illustrated. Final determination of the suitability for the use contemplated and its manner of use are the sole responsibility of the user. Structural design and analysis shall be performed by a qualified engineer.



FIGURE E:2 - ALTERNATE RAISED DRAINAGE PIPE LOCATIONS



**NOTE:**

Alternate raised drain pipe locations may only be used when:

- » The grade in front of the wall is flat and does not allow for gravity outlet of a pipe below the wall or through the base course of block.
- » There is no storm sewer system to outlet pipe directly into.

Only used when site geometry requires drain pipe to be raised in order to outlet at face.

\*See General Notes (p. 62) for drainage requirements.



KEystone COMPAC®

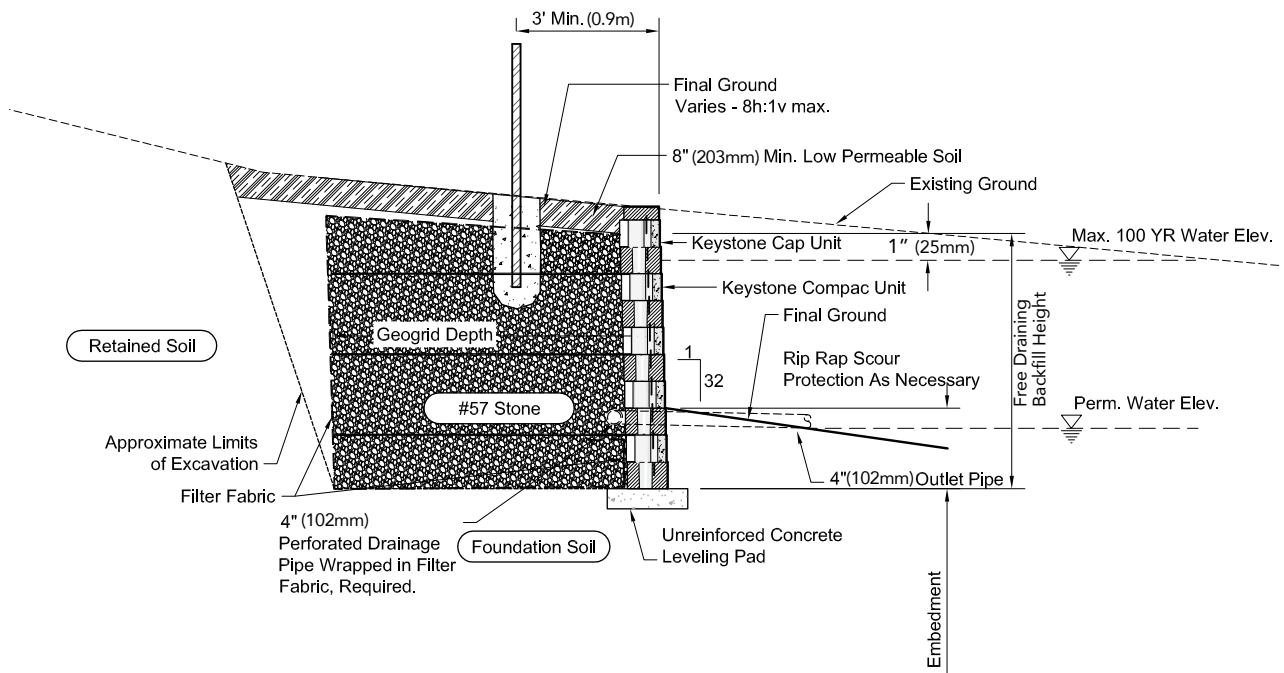
# Water Applications

When considering a water application for the Keystone wall system, the following areas need to be analyzed and designed to maintain structural integrity of the wall under normal, high wave and flooding water conditions:

- » Start by analyzing the wall under normal design criteria (i.e. wall height, base conditions, surcharge loads, soils data, reinforcement requirements, drainage, etc.)
- » Determine the water level on the wall under normal and adverse conditions.
- » Determine flow rate for streams, channels, etc.
- » Determine degree of wave action; minor, major or boat wake.
- » Determine the potential for flooding and inundation of the wall.
- » The above conditions should be taken into account in the design of the wall.

Always contact a professional engineer to assist you in your water application design. At minimum, the wall reinforced zone soils, to 1'(305mm) above the high water elevation, should be a free draining sand or gravel, wrapped in an appropriate filter fabric.

FIGURE E:3 - WATER APPLICATION

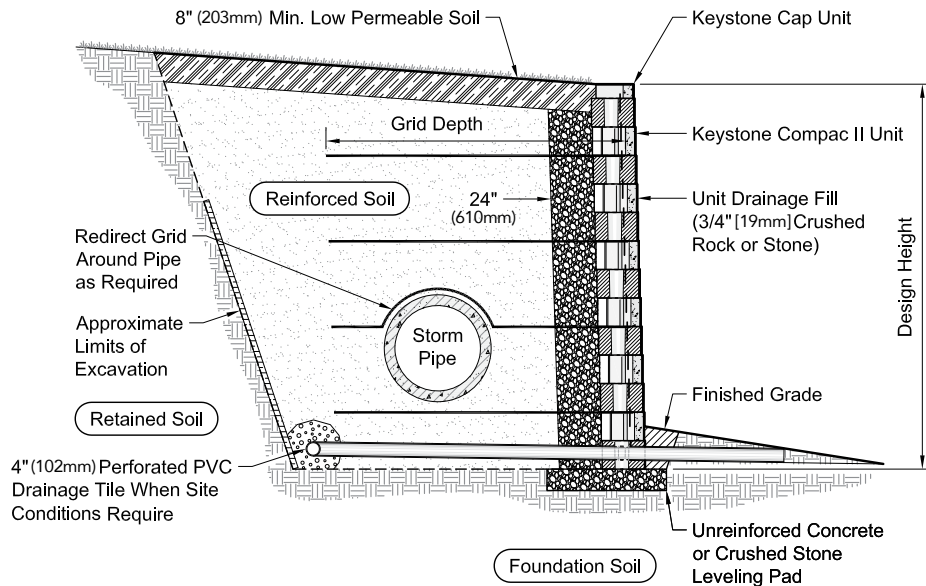


KEYSTONE COMPAC®

The information contained herein has been compiled by Keystone® Retaining Wall Systems LLC and to the best of our knowledge, accurately represents the Keystone product use in the applications which are illustrated. Final determination of the suitability for the use contemplated and its manner of use are the sole responsibility of the user. Structural design and analysis shall be performed by a qualified engineer.

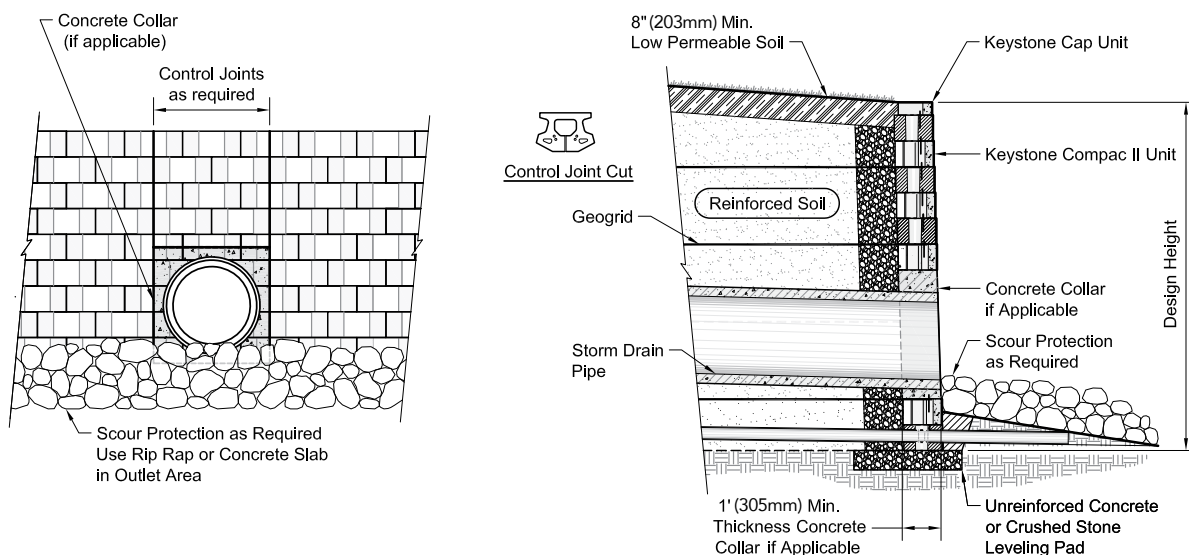
In general the placement of storm drains, parallel to the wall, within the reinforced soil zone, should be avoided. Any maintenance to the storm system, other than a reline, will require deconstruction of the wall down to the pipe elevation so fully intact geogrid can be re-installed during backfilling. Also, coordination of the utility and wall contractors will be necessary during initial construction of the wall to avoid excavation through the geogrid, after wall construction, to place the storm drain.

FIGURE E:4 - PIPE IN REINFORCED ZONE



The placement of storm drains perpendicular to the wall and outletting through the wall face are common. Since it is not possible to cut the block in a curve to fit tightly around the pipe, it is recommended that a cast in place collar be built around the pipe. The wall units can then be cut to the appropriate length and butted closely to the sides of the collar. Care should be taken to position the top of the collar within 1/2" to 1" (13mm to 25mm) below the horizontal joint of the block above. This action will allow placement of the next course of units onto a wet set mortar bed to achieve horizontal wall alignment.

FIGURE E:5 - TYPICAL PIPE OUTLET



The information contained herein has been compiled by Keystone Retaining Wall Systems® LLC and to the best of our knowledge, accurately represents the Keystone product use in the applications which are illustrated. Final determination of the suitability for the use contemplated and its manner of use are the sole responsibility of the user. Structural design and analysis shall be performed by a qualified engineer.

# Headwall Application

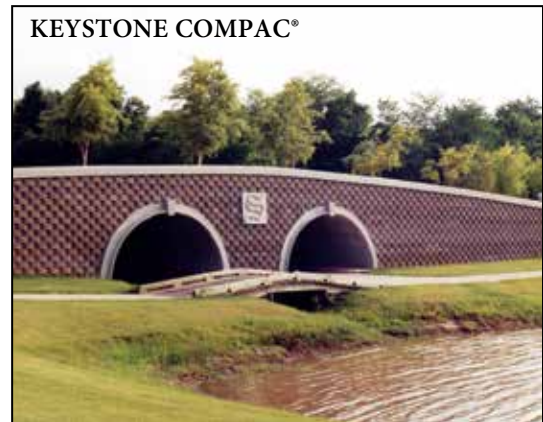
Keystone retaining walls are an economical and effective headwall system for many types of multi-plate arches, precast concrete panel arches, and various types of culverts:

**NOTE:**

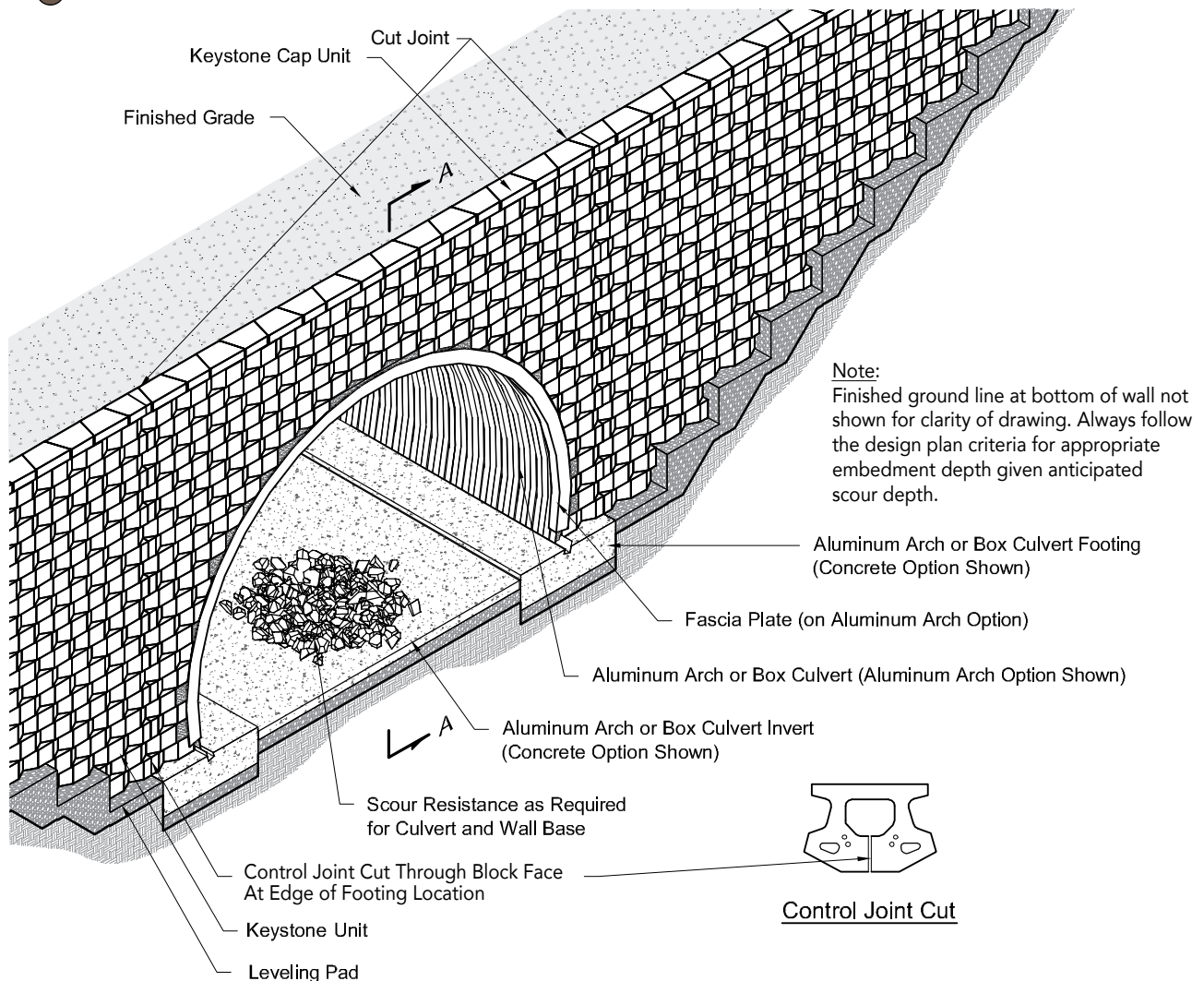
Total width of headwall face must be in full or half width unit increments.  
 Fascia plate shown is 6" x 4" x 5/16" (152 x 102 x 8mm) hot rolled steel angle (galvanized finish) or as specified. Use if desired to conceal rough cut Keystone unit edges for an aesthetic appearance.  
 Cut Keystone units to conform to arch or box culvert. Grout between block and plate using non-shrink type grout conforming to ASTM C1107. Maximum 3/4 inch (19mm) gap to be grouted with non-shrink grout.  
 When building the Keystone wall, backfill in equal lifts on each side of culvert. Measure for exact course height and unit running bond pattern on each side of arch or box culvert so they meet correctly at top of culvert.

**Pipe Zone Separation Notes:**

1. Drainage aggregate fill in the pipe zone is 3/8 inch to 3/4 inch (10 - 19mm) crushed stone.
2. Geotextile filter fabric should be placed along the arch and then extend behind the units. See Figure E:7.

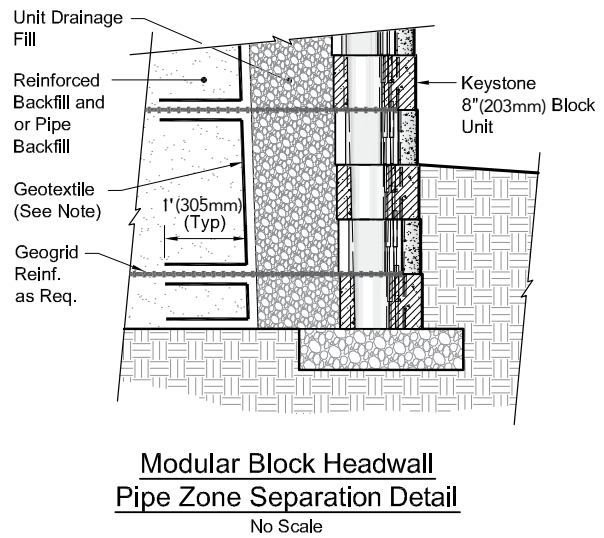
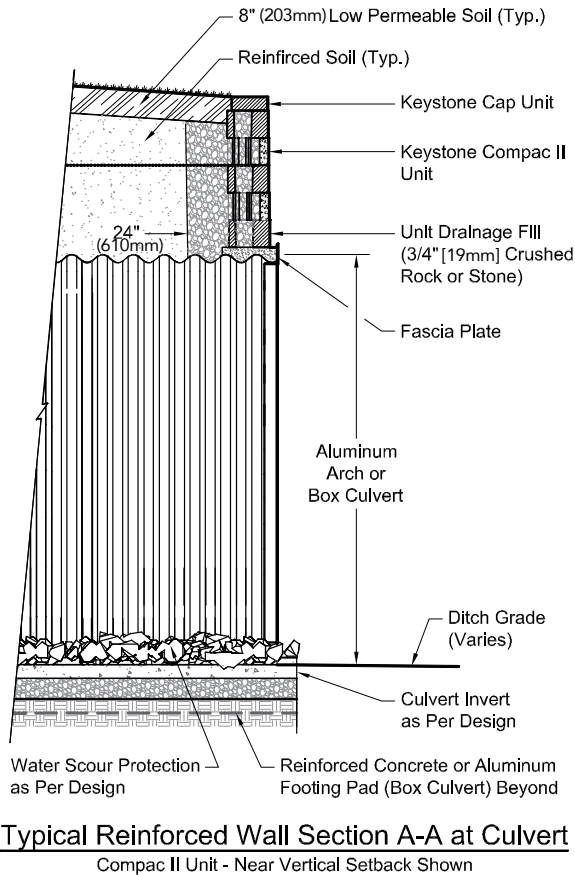
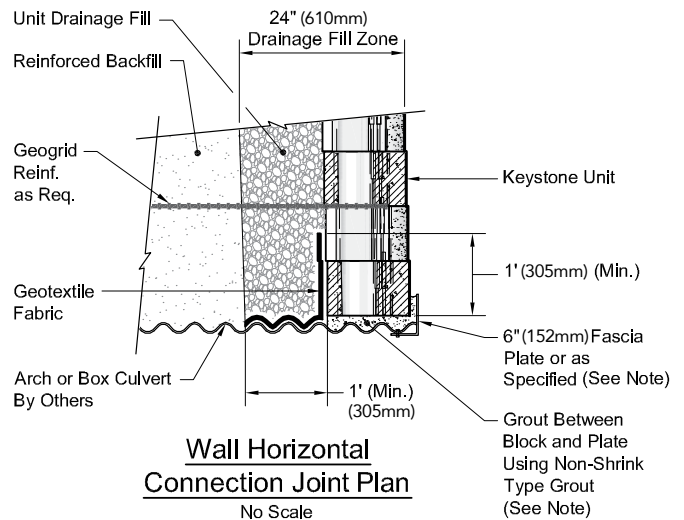
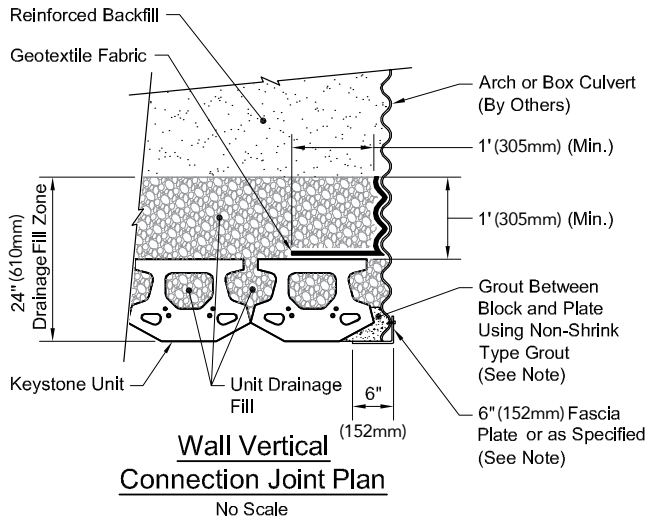


**FIGURE E:6 - TYPICAL DRAINAGE STRUCTURE**



The information contained herein has been compiled by Keystone Retaining Wall Systems® LLC and to the best of our knowledge, accurately represents the Keystone product use in the applications which are illustrated. Final determination of the suitability for the use contemplated and its manner of use are the sole responsibility of the user. Structural design and analysis shall be performed by a qualified engineer.

FIGURE E:7 - TYPICAL DRAINAGE STRUCTURE DETAILS



SECTION E: SPECIALTY - Headwall Application

The information contained herein has been compiled by Keystone Retaining Wall Systems® LLC and to the best of our knowledge, accurately represents the Keystone product use in the applications which are illustrated. Final determination of the suitability for the use contemplated and its manner of use are the sole responsibility of the user. Structural design and analysis shall be performed by a qualified engineer.

## Barriers: Introduction

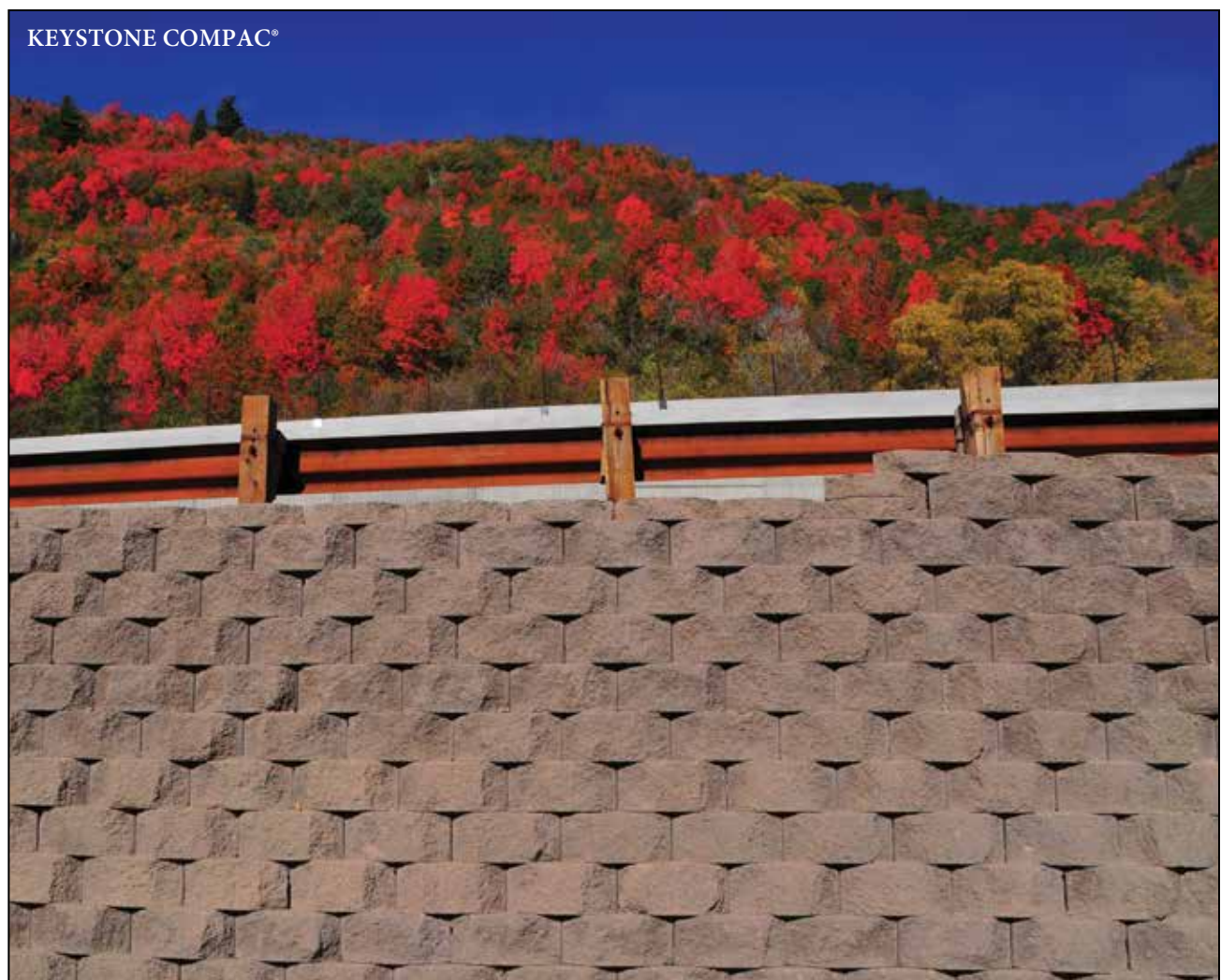
---

Keystone walls can readily be installed with many types of barrier systems. There are two main types of barriers: pedestrian fall protection devices and vehicular impact barriers.

Pedestrian fall protection devices come in various forms such as railings, fences or parapets. Most public design codes require some form of fall protection when a retaining wall reaches a specified height. Please contact your local building officials for code requirements in your area to determine if and when a fall protection device is required for your retaining wall. Keystone recommends fall protection be installed for all walls over 3 feet (0.9m) in height.

Vehicular barrier devices typically fall into two categories, flexible and rigid. Flexible barriers are the most common traffic impact barrier device due to the simplicity of installation and the fact that they are typically more cost effective than a rigid option.

When a flexible barrier is not an option, typically due to insufficient room to install a guardrail at the top of a wall, often times a rigid cast in place (CIP) concrete traffic barrier is the next best solution. CIP concrete traffic barriers are most commonly used in DOT applications, but can also be specified in private application roadways with heavy traffic areas. CIP concrete traffic barriers can vary greatly by the application type, location, or design codes. Refer to state DOT agencies for specific details related to traffic barriers and MSE walls.



The information contained herein has been compiled by Keystone Retaining Wall Systems® LLC and to the best of our knowledge, accurately represents the Keystone product use in the applications which are illustrated. Final determination of the suitability for the use contemplated and its manner of use are the sole responsibility of the user. Structural design and analysis shall be performed by a qualified engineer.

When installing a guardrail with a Keystone wall, there are three important guidelines that must be met as mandated by The American Association of State Highway Transportation Officials (AASHTO).

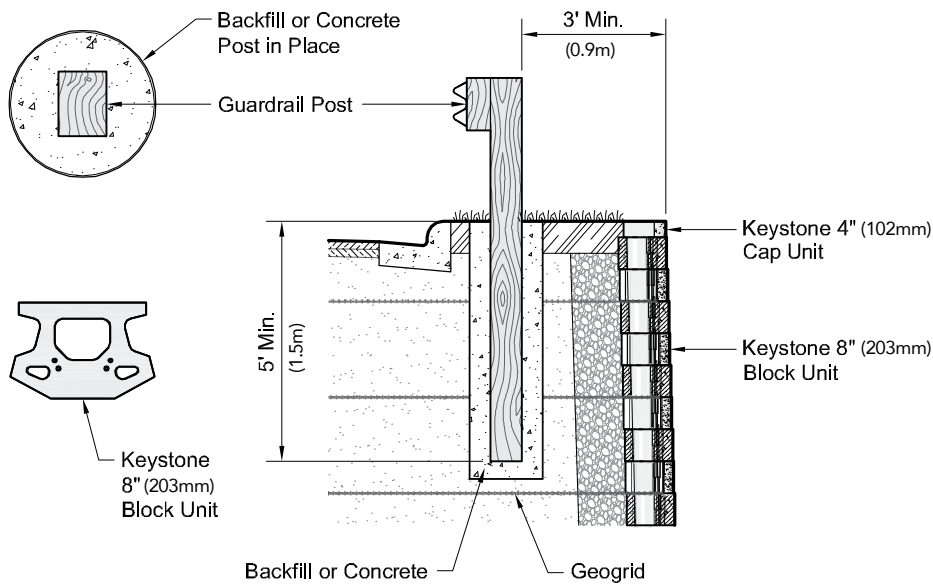
1. The guardrail must be located a minimum of 3 feet (0.9m) from a wall face.
2. The guardrail post shall be placed a minimum 5 feet (1.5m) into the ground.
3. The guardrail shall extend through a minimum of 2 geogrid layers.

There are a number of installation methods for a guardrail with a Keystone wall. Always reference the project-engineered drawings for the preferred installation method.

1. Sleeves can be installed during wall construction for the guardrail foundation posts.
2. Wooden posts can be augered into the ground after wall construction (installing sleeves during wall construction is the preferred method).
3. Steel posts can be driven into the ground after wall construction.



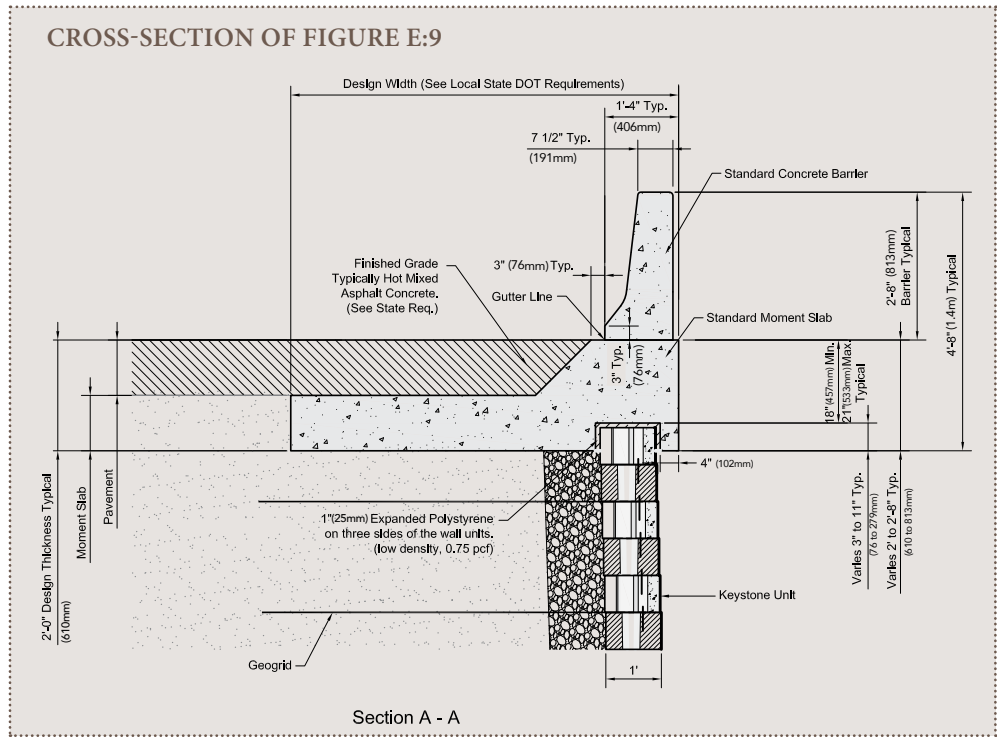
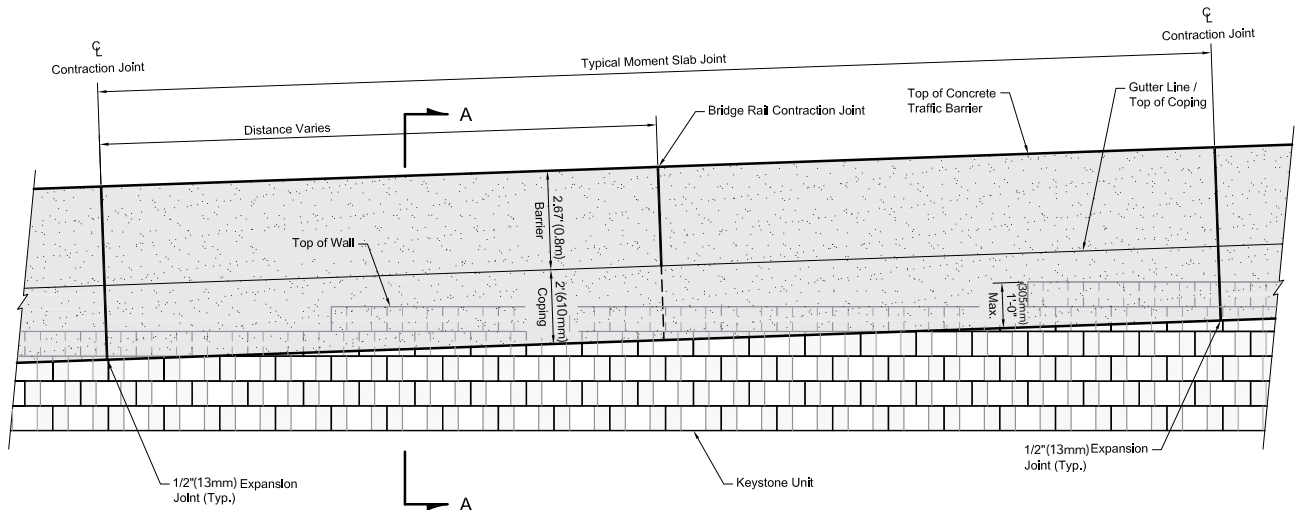
FIGURE E:8 - TYPICAL GUARDRAIL CROSS SECTION



# Barriers: Cast in Place Concrete Traffic Barrier

Concrete traffic barrier systems on MSE walls are most commonly used in highway applications. These barrier systems consist of a traffic barrier placed on a continuous footing or structural slab (moment slab). In recent years, the MSE wall industry has seen considerable advances in research and development, better understanding the complex nature of the distribution of loads from the barrier through the wall systems. As a result of these new studies and developments, individual state agencies have begun to develop and design specific barriers and moment slabs to meet their local conditions and design codes. Subsequently, there is no longer a “one size fits all” approach to traffic barrier systems but, instead, more of a general design basis which each state utilizes to develop details. The details found in this section are intended to show the basic concept of an interaction between a Keystone MSE wall and a barrier. For more in-depth details, please visit or contact your state DOT agency.

**FIGURE E:9 - PARTIAL CAST IN PLACE TRAFFIC BARRIER**



**NOTES:**

1. Concrete moment slab and barrier are shown for general concept purposes only. Reinforcing steel not included as part of these drawings. Contact your local State DOT for state-specific barrier details.
2. Provide materials and perform all work in accordance with current State Standard Specifications for construction.
3. Dimensions provided for reference only. See State DOT details for specific dimensions.

The information contained herein has been compiled by Keystone Retaining Wall Systems® LLC and to the best of our knowledge, accurately represents the Keystone product use in the applications which are illustrated. Final determination of the suitability for the use contemplated and its manner of use are the sole responsibility of the user. Structural design and analysis shall be performed by a qualified engineer.



## Barriers: Cast in Place Concrete Traffic Barrier



# Barriers: Fencing Options

Fences can be placed at the top of a Keystone wall with fence posts placed behind the Keystone units. The choice, location, and compliance with local codes of the appropriate fall protection system, is the responsibility of the owner and site engineer. Follow these procedures for proper installation of fence posts with Keystone walls.

1. Install the Keystone wall per general installation instructions.
2. Fence posts positioned behind the Keystone units may be installed and anchored using a variety of installation methods.
3. These details can also be used for Keystone Standard units.

FIGURE E:10 - TYPICAL FENCE POST OFFSET

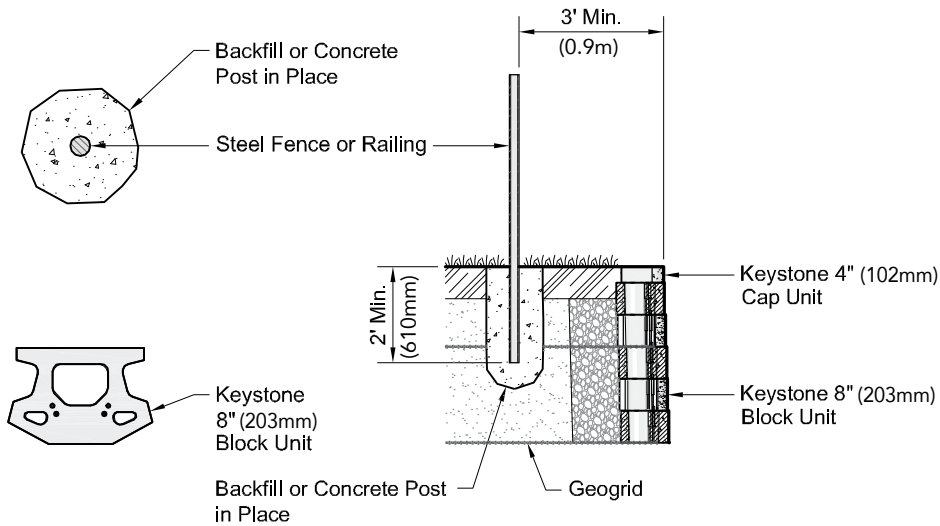
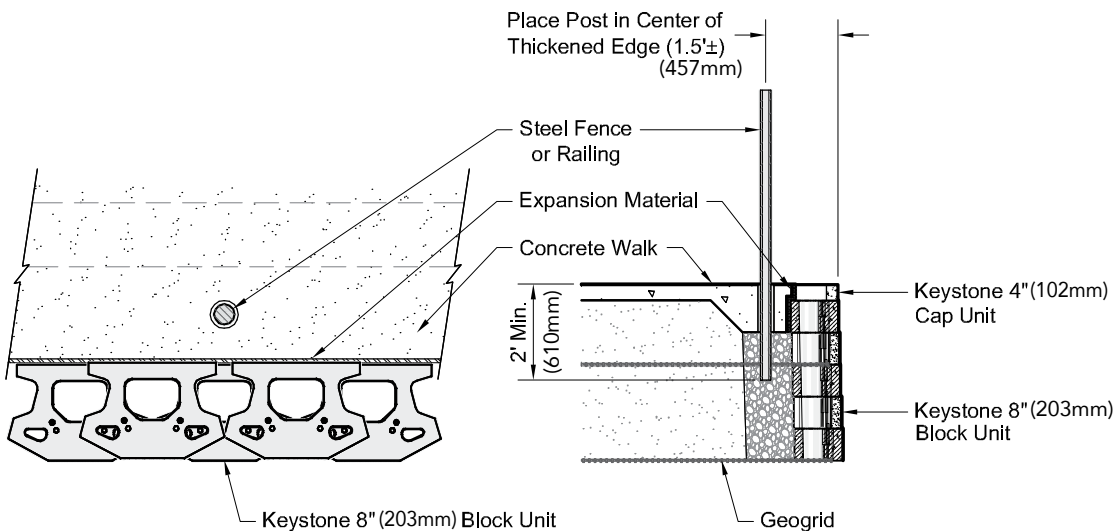
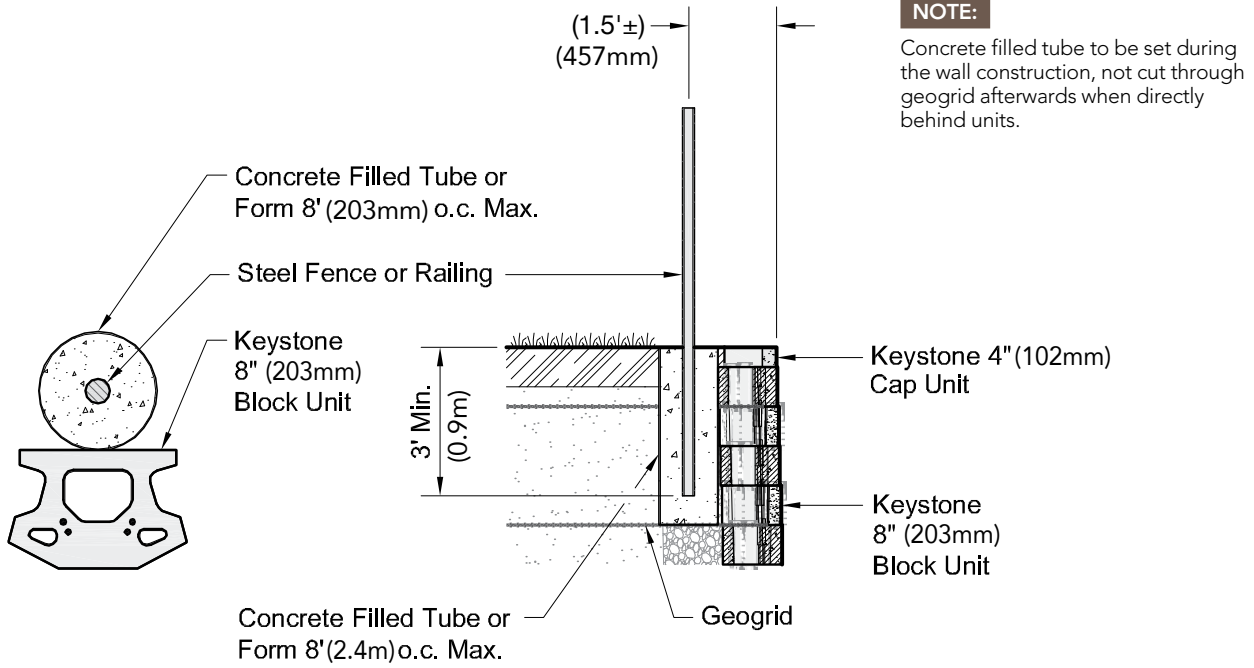


FIGURE E:11 - INTEGRATED SIDEWALK & FENCE



The information contained herein has been compiled by Keystone Retaining Wall Systems® LLC and to the best of our knowledge, accurately represents the Keystone product use in the applications which are illustrated. Final determination of the suitability for the use contemplated and its manner of use are the sole responsibility of the user. Structural design and analysis shall be performed by a qualified engineer.

FIGURE E:12 - MINIMUM FENCE OFFSET



KEYSTONE STANDARD®

The information contained herein has been compiled by Keystone Retaining Wall Systems® LLC and to the best of our knowledge, accurately represents the Keystone product use in the applications which are illustrated. Final determination of the suitability for the use contemplated and its manner of use are the sole responsibility of the user. Structural design and analysis shall be performed by a qualified engineer.

## Barriers: Special Fence Installation - Standard Unit Only

Keystone Standard units are always recommended in situations where railings are considered for direct mounting on the wall system. The Keystone Standard unit is typically large enough to satisfy a 20plf or 200lbs (91kg) post minimum IBC loading, provided that the post is grouted into the upper three courses as shown below. Shear resistance of Standard units (>1000plf) exceeds the driving forces (20plf) by a wide margin in a gravity wall application and is not a critical evaluation. Railing shall not exceed maximum height of 42 inches (1.1m) above the units.

FIGURE E:13 - DIRECT MOUNT RAILING IN STANDARD UNIT WALL - NEAR VERTICAL

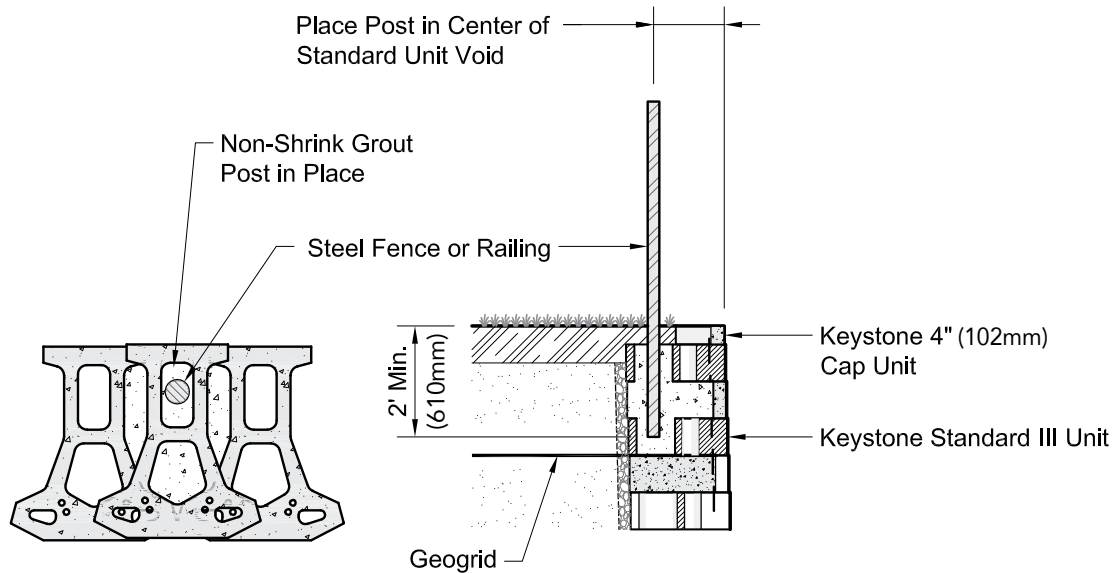
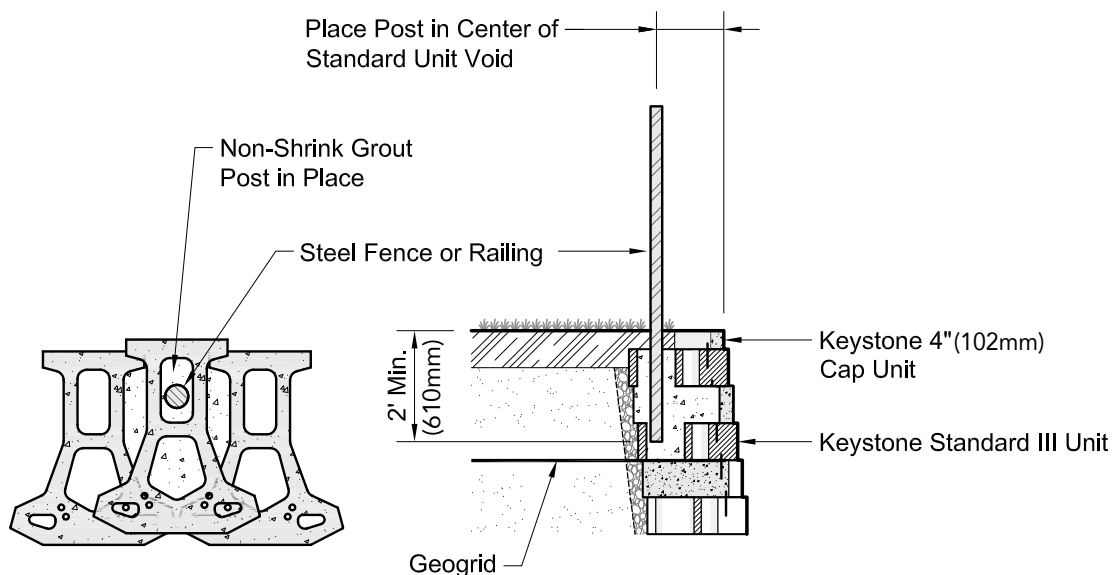


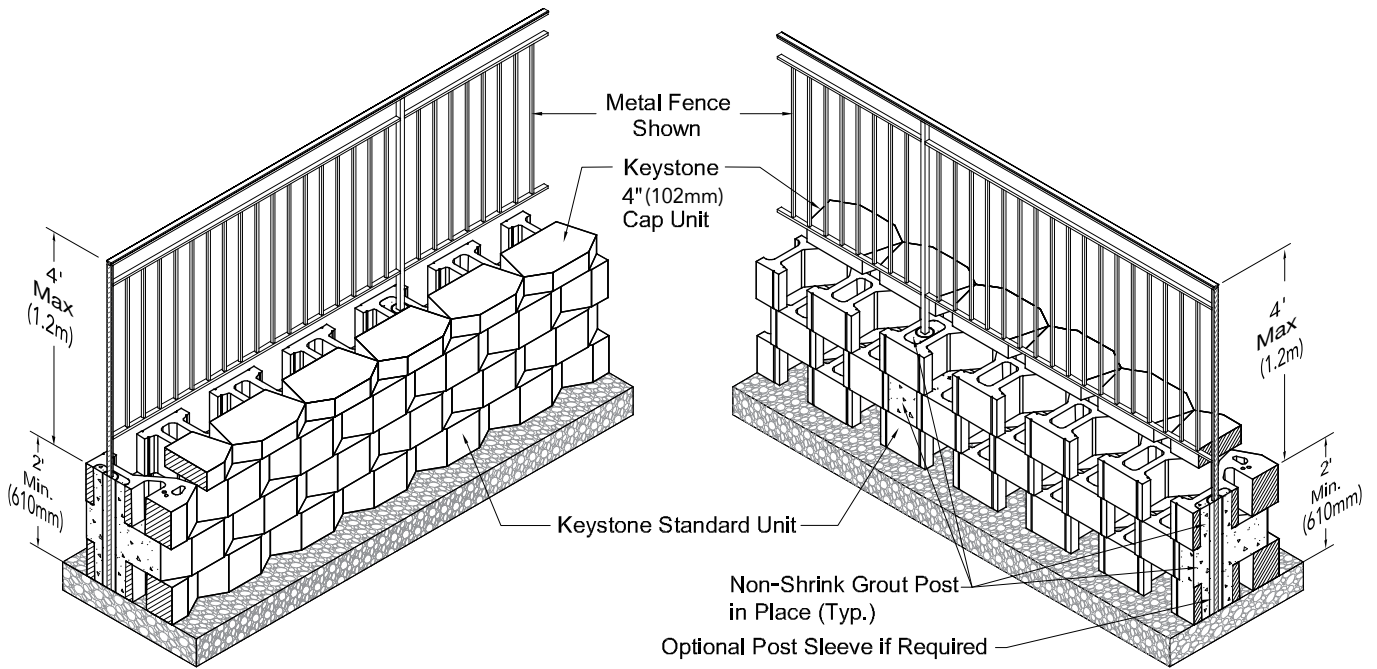
FIGURE E:14 - DIRECT MOUNT RAILING IN STANDARD UNIT WALL - 1" SETBACK



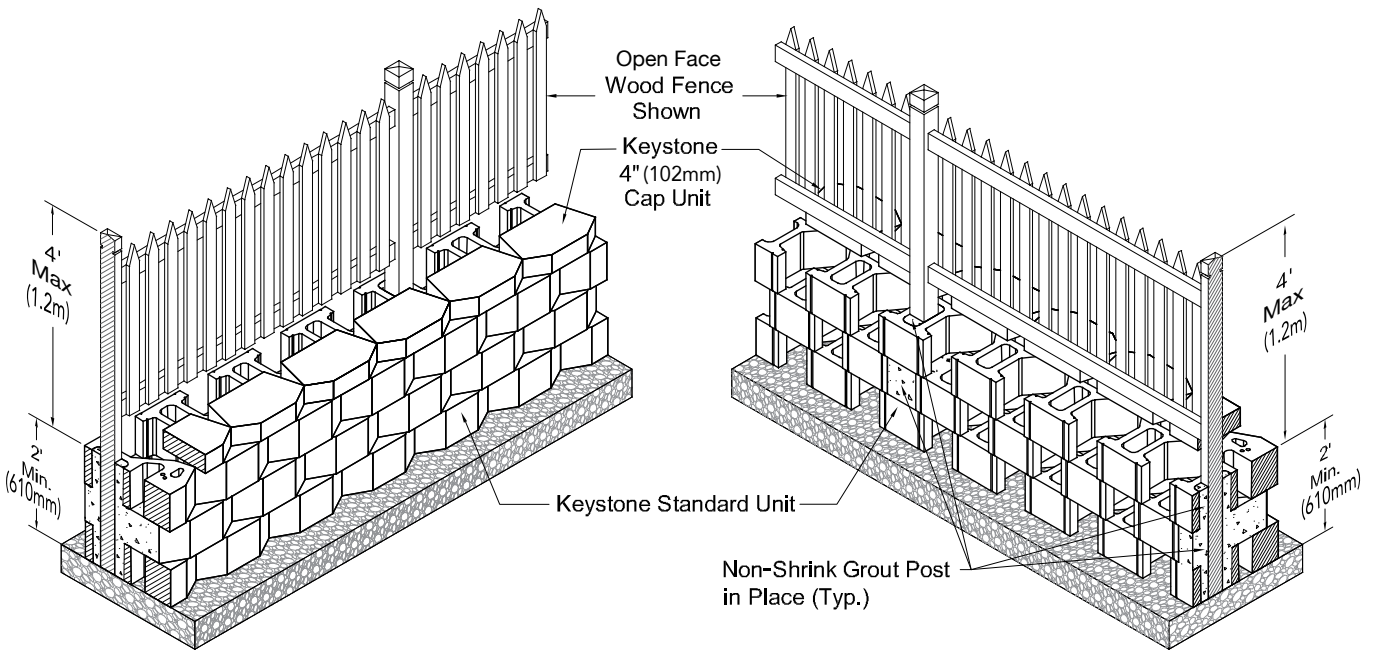
The information contained herein has been compiled by Keystone Retaining Wall Systems® LLC and to the best of our knowledge, accurately represents the Keystone product use in the applications which are illustrated. Final determination of the suitability for the use contemplated and its manner of use are the sole responsibility of the user. Structural design and analysis shall be performed by a qualified engineer.

# Barriers: Special Fence Installation - Standard Unit Only

**FIGURE E:15 - ROUND POST**  
(post size shall not exceed 3" [76mm] diameter)



**FIGURE E:16 - SQUARE POST**  
(post size embedded in units shall not exceed 3" x 3" [76mm x 76mm])



The information contained herein has been compiled by Keystone Retaining Wall Systems® LLC and to the best of our knowledge, accurately represents the Keystone product use in the applications which are illustrated. Final determination of the suitability for the use contemplated and its manner of use are the sole responsibility of the user. Structural design and analysis shall be performed by a qualified engineer.

# Barriers: Parapet

Back-to-back parapet walls are sometimes placed above a Keystone wall. Figures E:17 to E:20 illustrate the concept of parapet wall layout and design. Care should be taken to properly compact the wall backfill and the 24" (610mm) drainage column behind the wall to minimize settlement and tilting of the parapet.

FIGURE E:17 - TYPICAL PARAPET COURSE PLANS

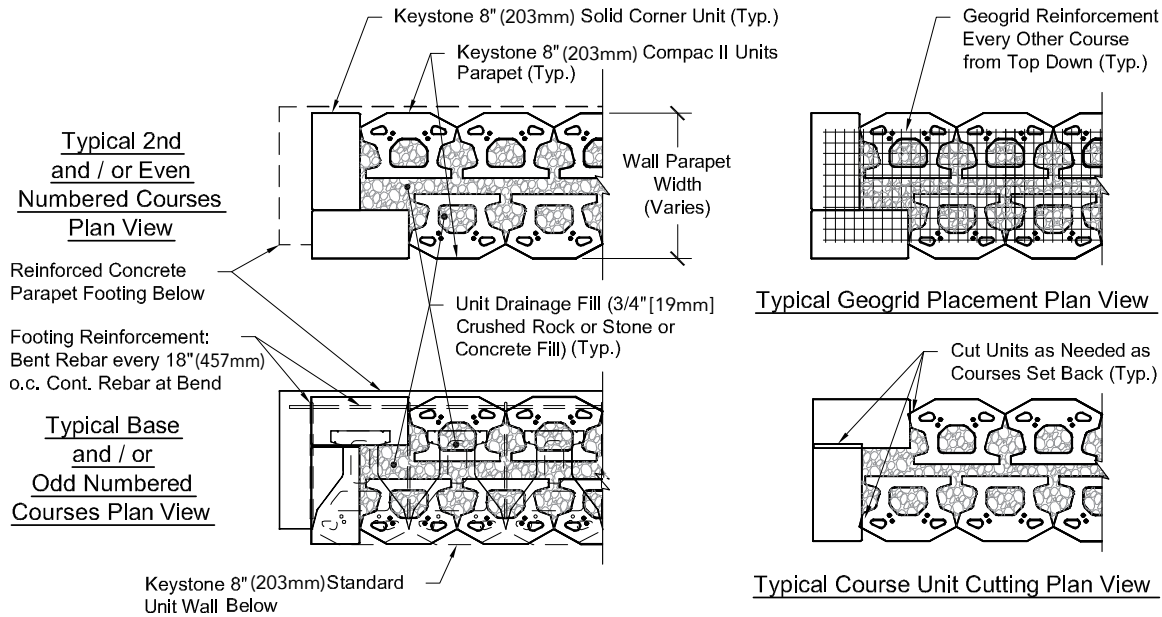
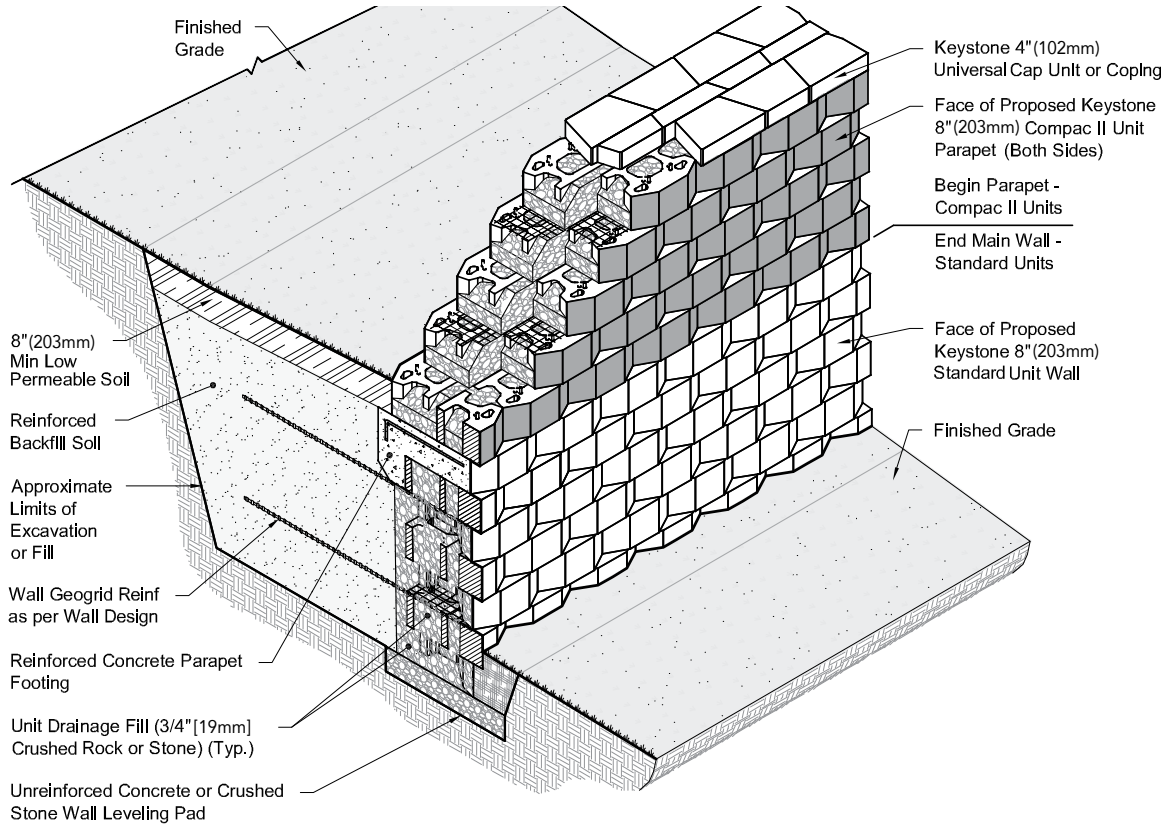


FIGURE E:18 - WALL/PARAPET SECTION VIEW (STANDARD & COMPAC UNITS)



The information contained herein has been compiled by Keystone Retaining Wall Systems® LLC and to the best of our knowledge, accurately represents the Keystone product use in the applications which are illustrated. Final determination of the suitability for the use contemplated and its manner of use are the sole responsibility of the user. Structural design and analysis shall be performed by a qualified engineer.

FIGURE E:19 - WALL/PARAPET CAPPING & END SECTION VIEW (STANDARD & COMPAC UNITS)

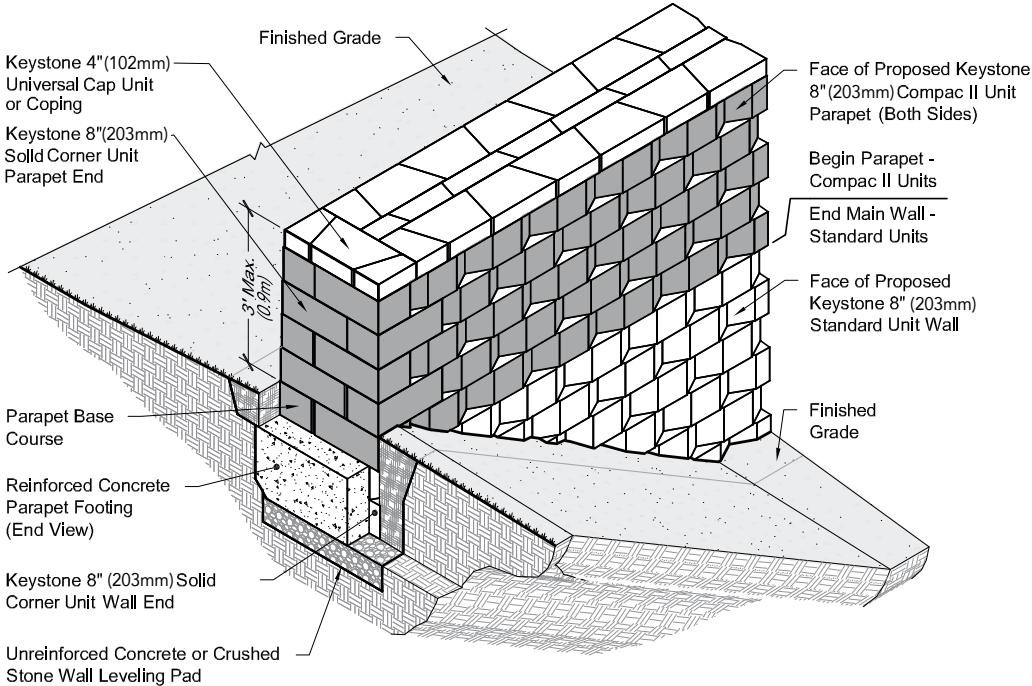
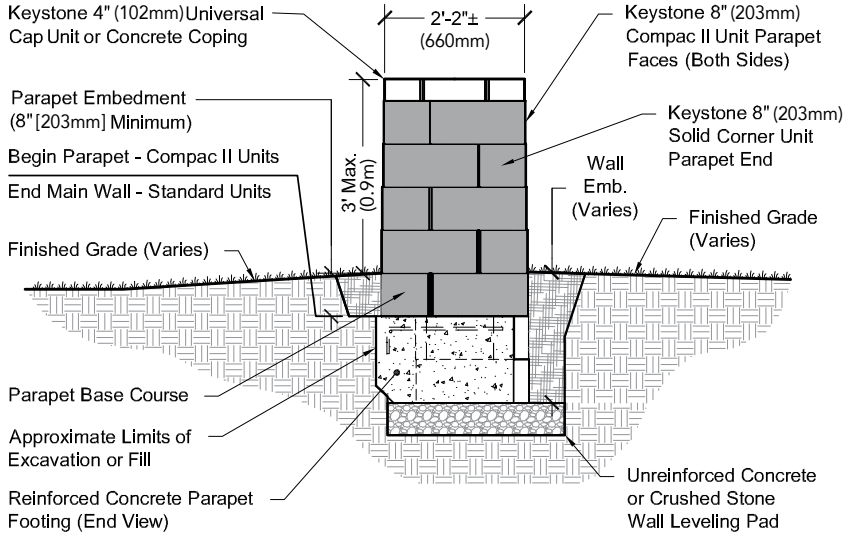


FIGURE E:20 - PARAPET END SECTION VIEW



The information contained herein has been compiled by Keystone Retaining Wall Systems® LLC and to the best of our knowledge, accurately represents the Keystone product use in the applications which are illustrated. Final determination of the suitability for the use contemplated and its manner of use are the sole responsibility of the user. Structural design and analysis shall be performed by a qualified engineer.

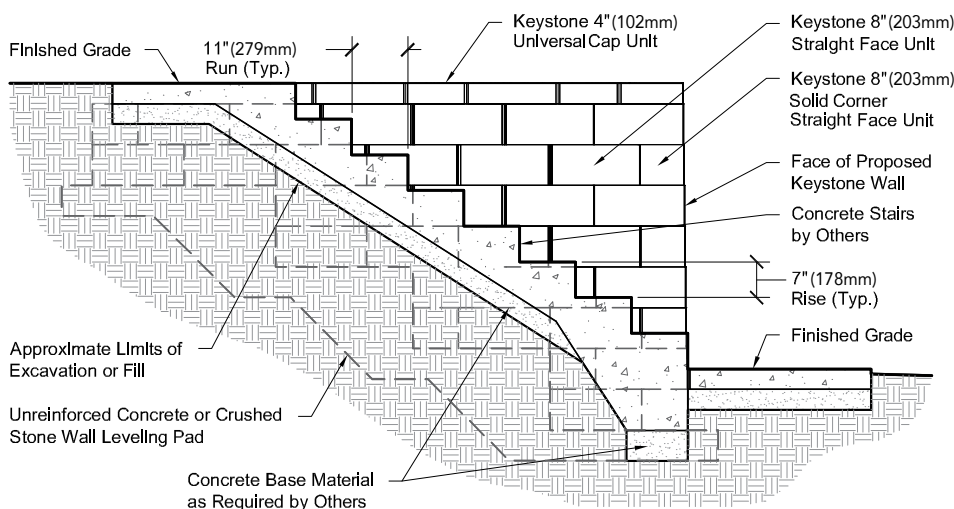
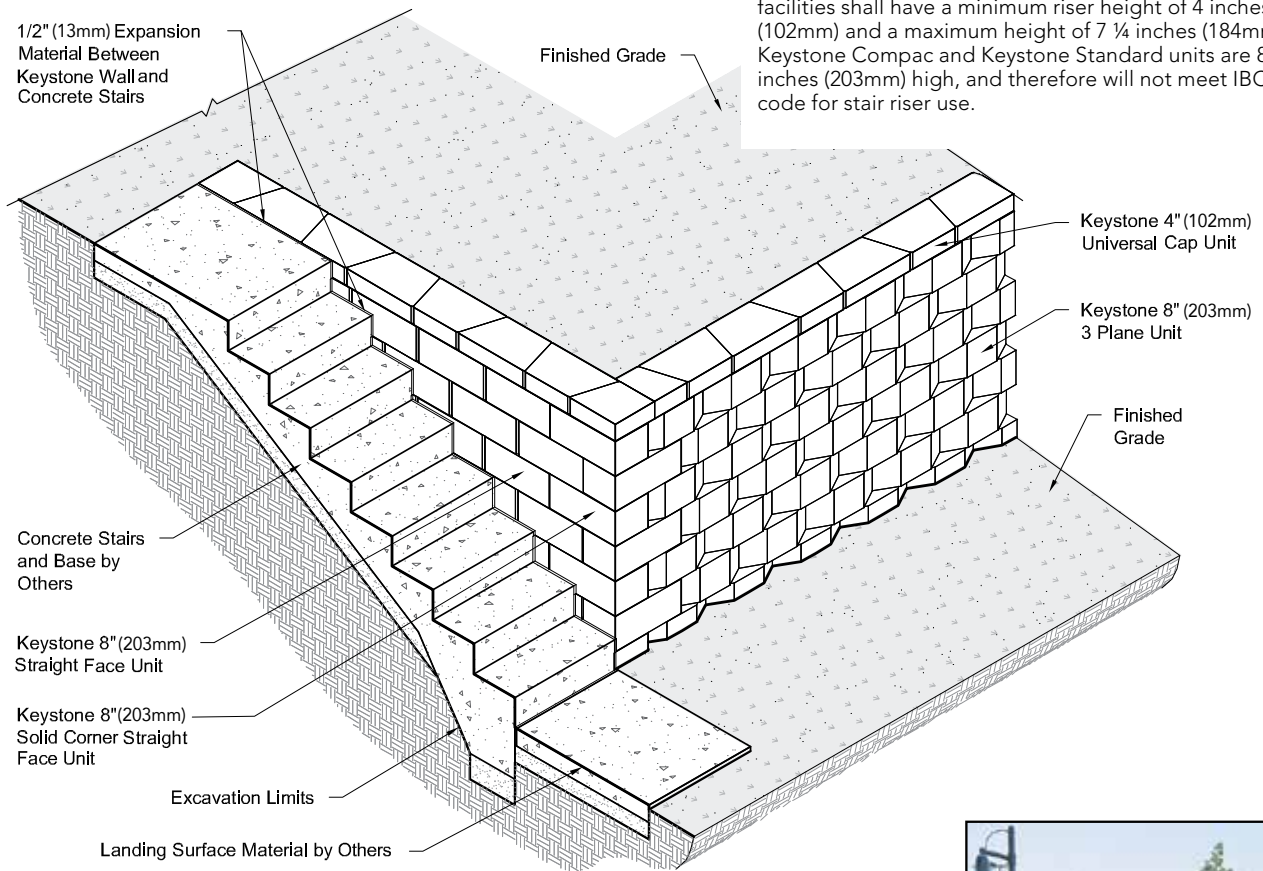
# Step & Stair Installation

Keystone walls can easily be constructed to incorporate CIP concrete stairs within the wall systems. The stairways can be designed to be incorporated into a 90 degree wall return (see Figure E:21), or project out from the wall face (see Figure E:24). Construct the Keystone wall as per design. Where a stairway is proposed, create a 90° outside corner with Keystone straight face and corner units. Construct the CIP concrete stairs as the project plans, making sure they include a 1/2 inch (13mm) expansion joint between the stairs and the Keystone units.

**NOTE:**

International Building Code (IBC) indicates that stair facilities shall have a minimum riser height of 4 inches (102mm) and a maximum height of 7 1/4 inches (184mm). Keystone Compac and Keystone Standard units are 8 inches (203mm) high, and therefore will not meet IBC code for stair riser use.

**FIGURE E:21 - INSET STAIRWAY DETAILS**



The information contained herein has been compiled by Keystone Retaining Wall Systems® LLC and to the best of our knowledge, accurately represents the Keystone product use in the applications which are illustrated. Final determination of the suitability for the use contemplated and its manner of use are the sole responsibility of the user. Structural design and analysis shall be performed by a qualified engineer.



FIGURE E:22 - STAIR IN WALL DETAIL PLAN VIEWS

**NOTE:**

Use Keystone Compac straight face units in return walls along concrete stair for ease of stair installation and for placement of bond breaker material between stair and wall.

Tread depths and riser heights may vary depending on design and/or local codes.

Install hand railing as per local codes.

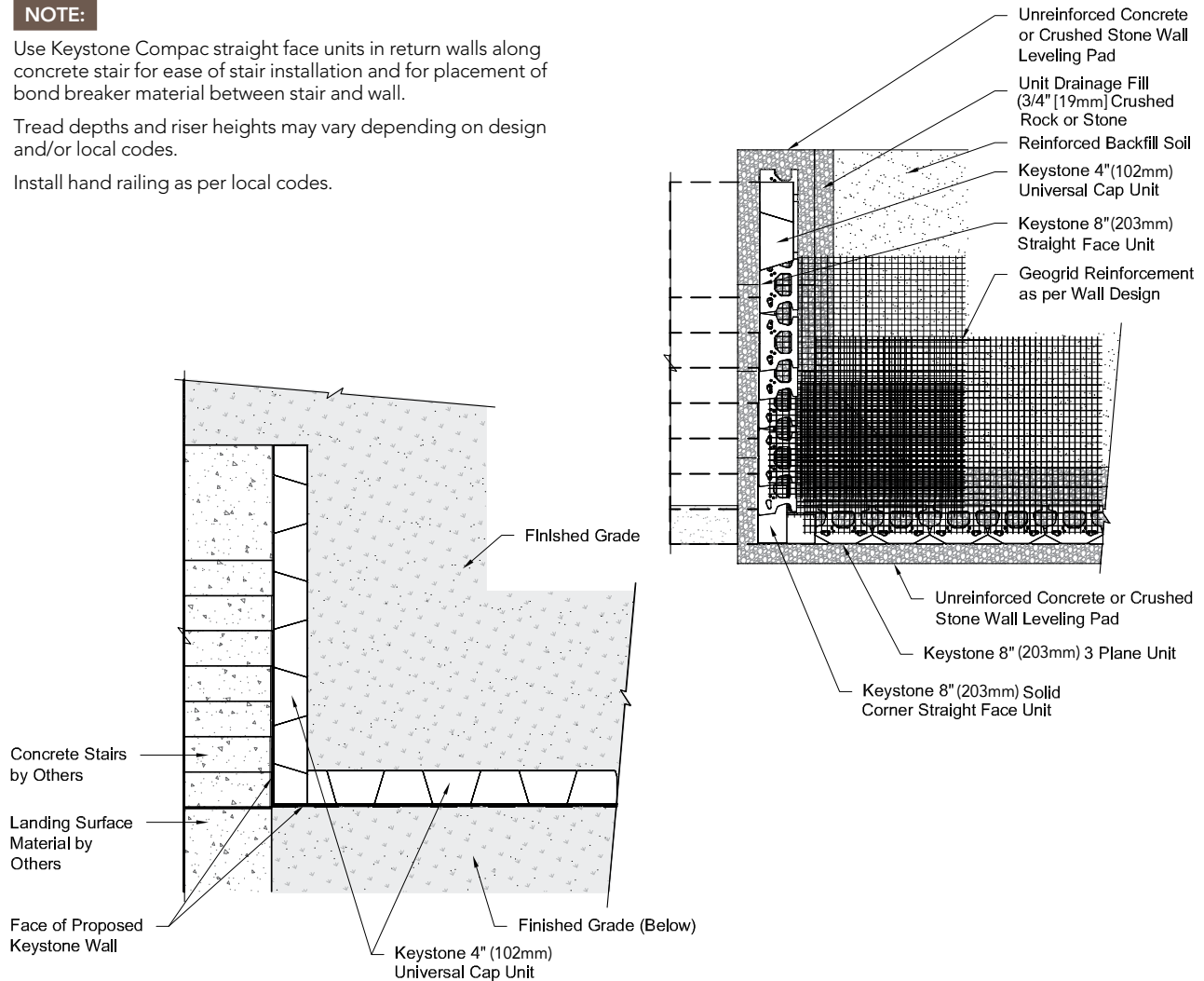
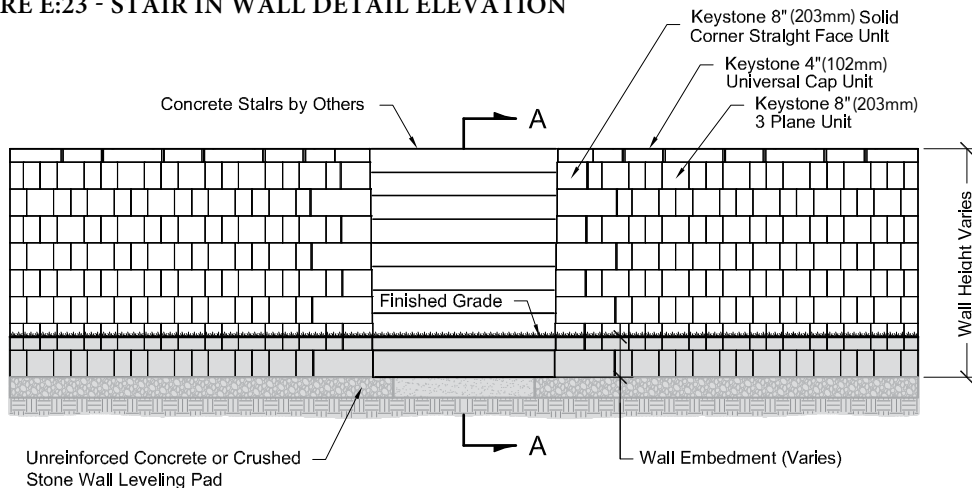


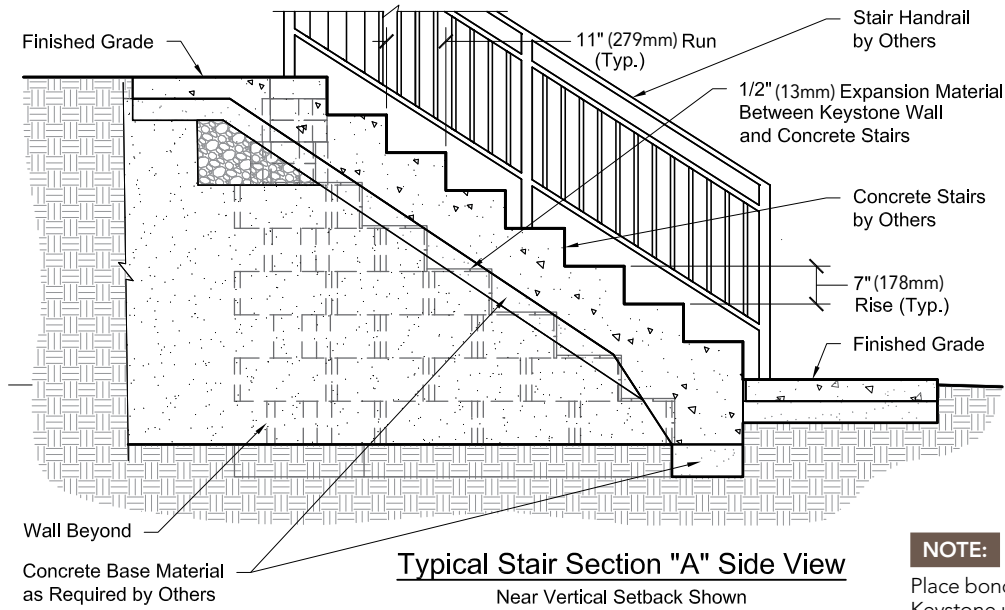
FIGURE E:23 - STAIR IN WALL DETAIL ELEVATION



The information contained herein has been compiled by Keystone Retaining Wall Systems® LLC and to the best of our knowledge, accurately represents the Keystone product use in the applications which are illustrated. Final determination of the suitability for the use contemplated and its manner of use are the sole responsibility of the user. Structural design and analysis shall be performed by a qualified engineer.

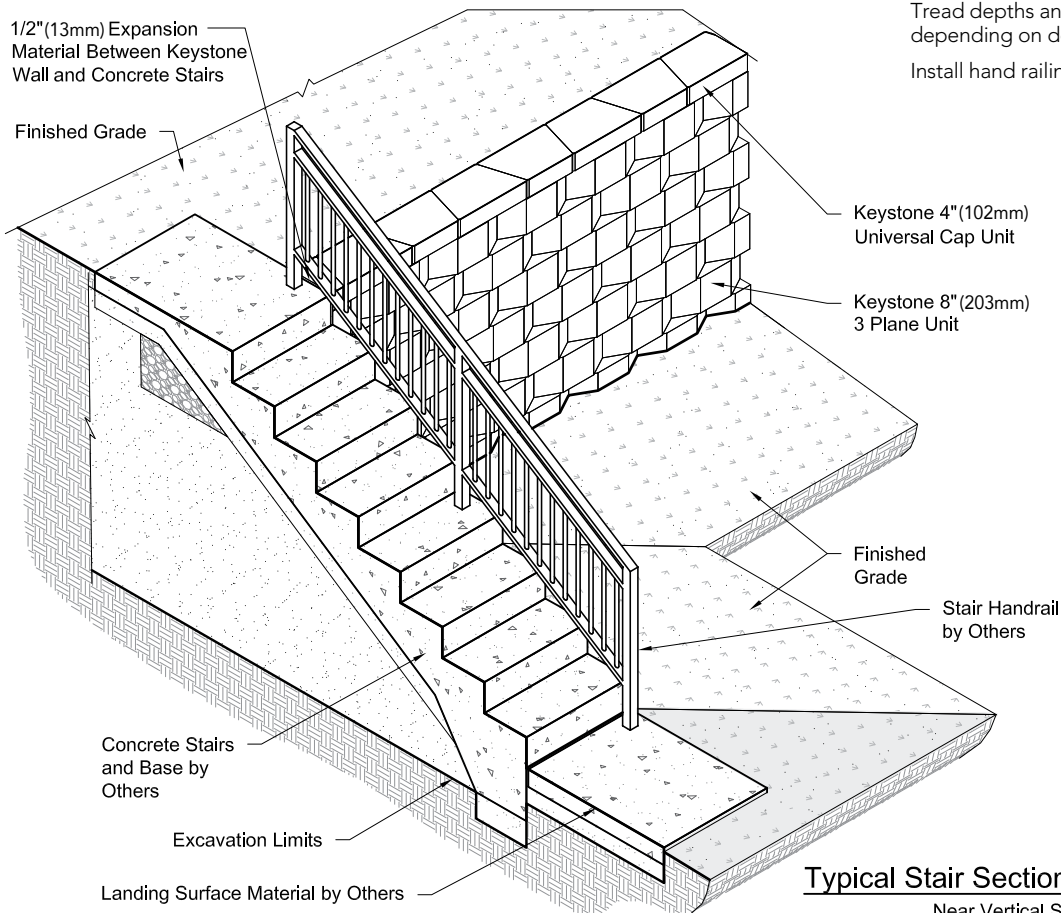
# Step & Stair Installation

FIGURE E:24 - PROJECTED STAIRWAY DETAIL



**NOTE:**

Place bond breaker material between Keystone units and concrete stair. Stair designs may vary.  
Tread depths and riser heights may vary depending on design and or local codes.  
Install hand railing as per local codes.



The information contained herein has been compiled by Keystone Retaining Wall Systems® LLC and to the best of our knowledge, accurately represents the Keystone product use in the applications which are illustrated. Final determination of the suitability for the use contemplated and its manner of use are the sole responsibility of the user. Structural design and analysis shall be performed by a qualified engineer.

FIGURE E:25 - STAIR IN FRONT OF WALL DETAIL PLAN VIEWS

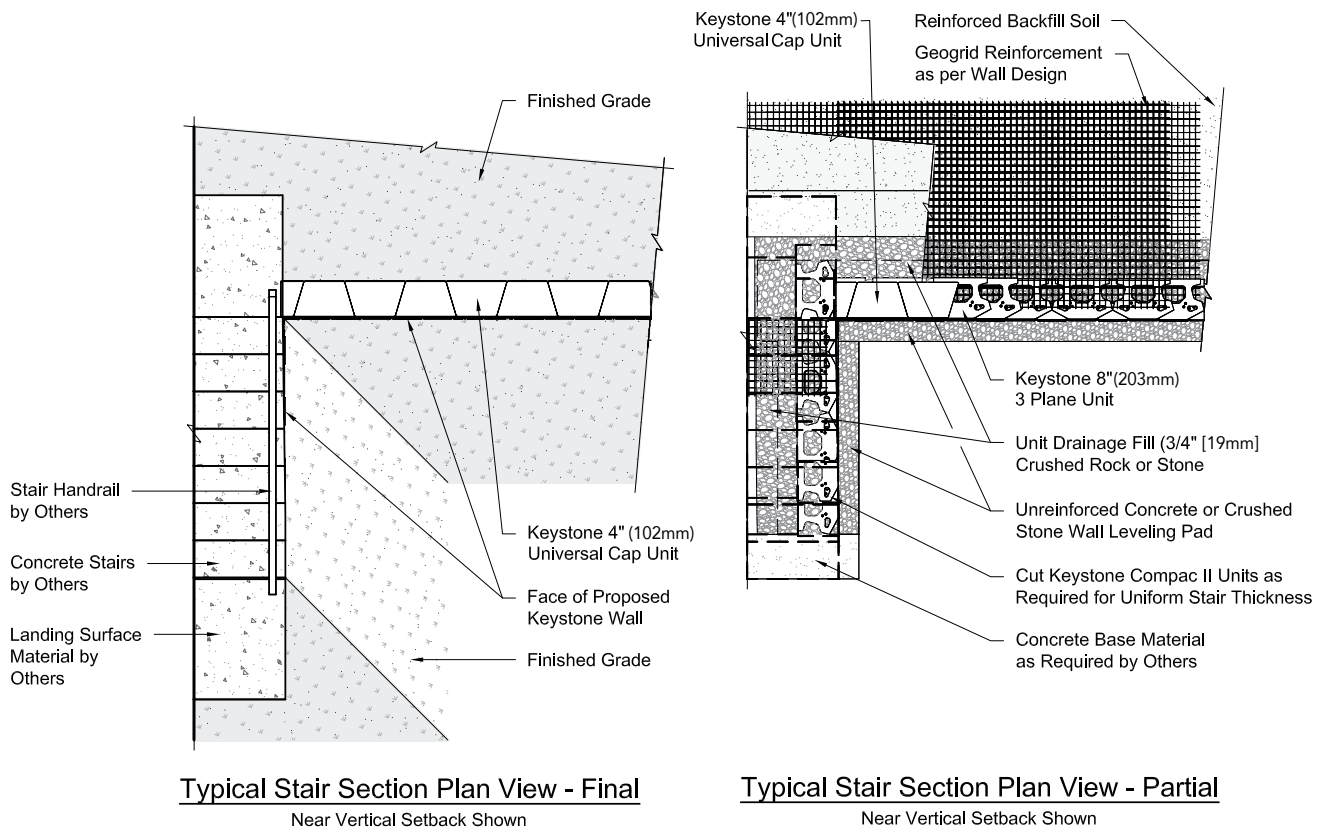
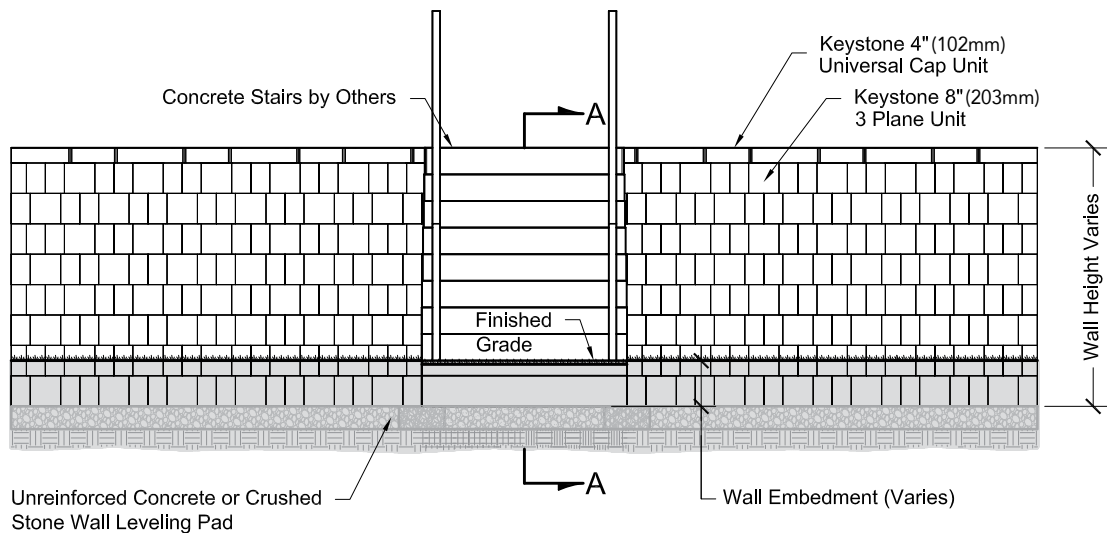


FIGURE E:26 - STAIR IN FRONT OF WALL DETAIL ELEVATION



SECTION E: SPECIALTY - Step & Stair

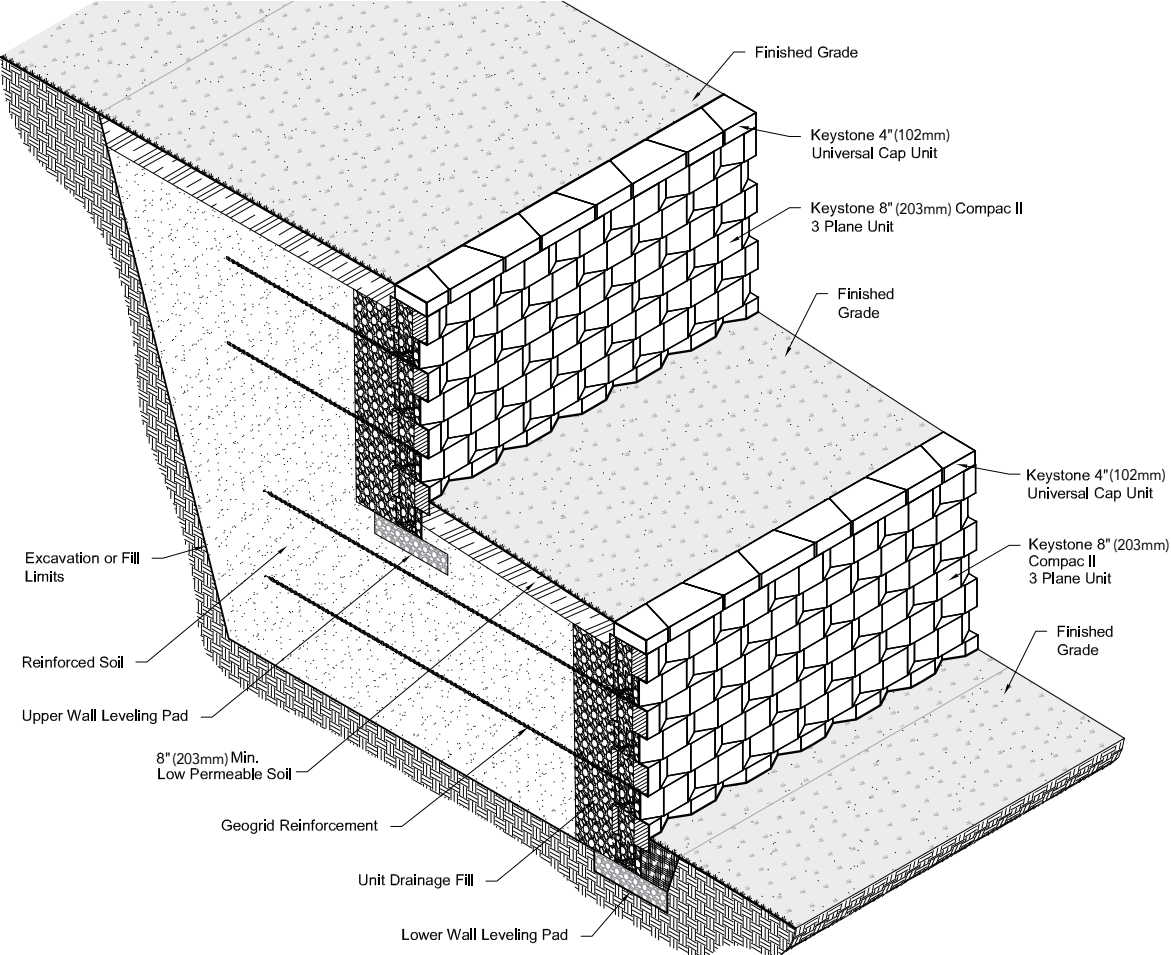
The information contained herein has been compiled by Keystone Retaining Wall Systems® LLC and to the best of our knowledge, accurately represents the Keystone product use in the applications which are illustrated. Final determination of the suitability for the use contemplated and its manner of use are the sole responsibility of the user. Structural design and analysis shall be performed by a qualified engineer.

# Terraced Wall Application

Terraced Keystone walls can provide a visually appealing solution to grade change. Slope conditions below, between and above the walls, soil conditions and the horizontal distance between the walls will impact terraced wall design. In many cases, the geogrid lengths of the lower wall will be longer than typical to satisfy stability requirements. Always consult a qualified design professional for assistance with terraced walls.



FIGURE E:27 - TYPICAL TERRACED WALL ISOMETRIC .



The information contained herein has been compiled by Keystone Retaining Wall Systems® LLC and to the best of our knowledge, accurately represents the Keystone product use in the applications which are illustrated. Final determination of the suitability for the use contemplated and its manner of use are the sole responsibility of the user. Structural design and analysis shall be performed by a qualified engineer.



The information contained herein has been compiled by Keystone Retaining Wall Systems® LLC and to the best of our knowledge, accurately represents the Keystone product use in the applications which are illustrated. Final determination of the suitability for the use contemplated and its manner of use are the sole responsibility of the user. Structural design and analysis shall be performed by a qualified engineer.

# Wall Repair

**PROBLEM:** Damaged or cracked unit in wall.

**SOLUTION:** For minor cracks, fill opening with construction epoxy and dust lightly with concrete material of similar color. Use a ground up piece from another Keystone unit.

For low height walls, dismantle units down to broken unit(s), replace with new unit(s). Rebuild wall placing corefill and backfill with necessary compaction until capping of wall as shown in above detail.

For taller walls or where it is not practical to dismantle the wall, follow steps shown in the details below. (see Figure E:29)

FIGURE E:28 - REPLACE CRACKED UNIT

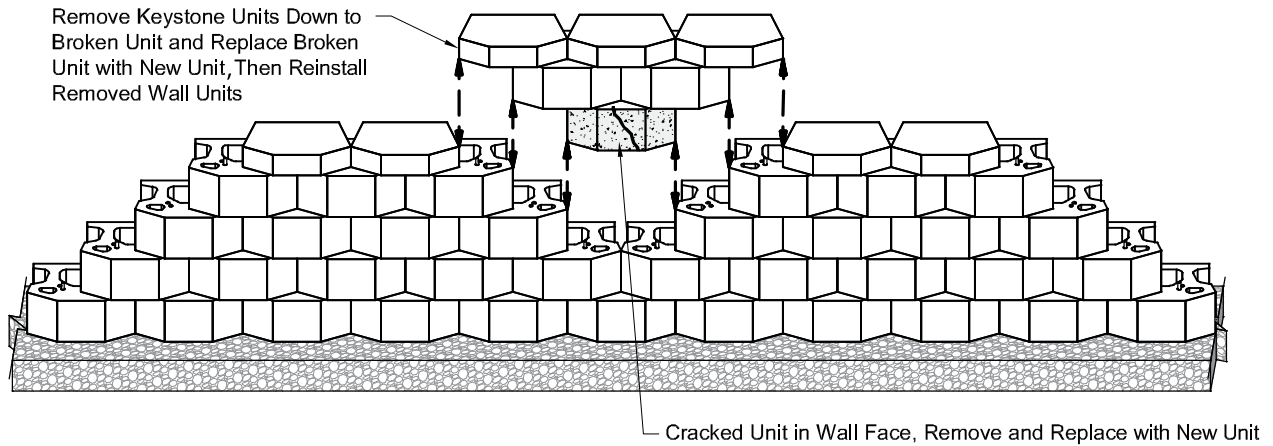
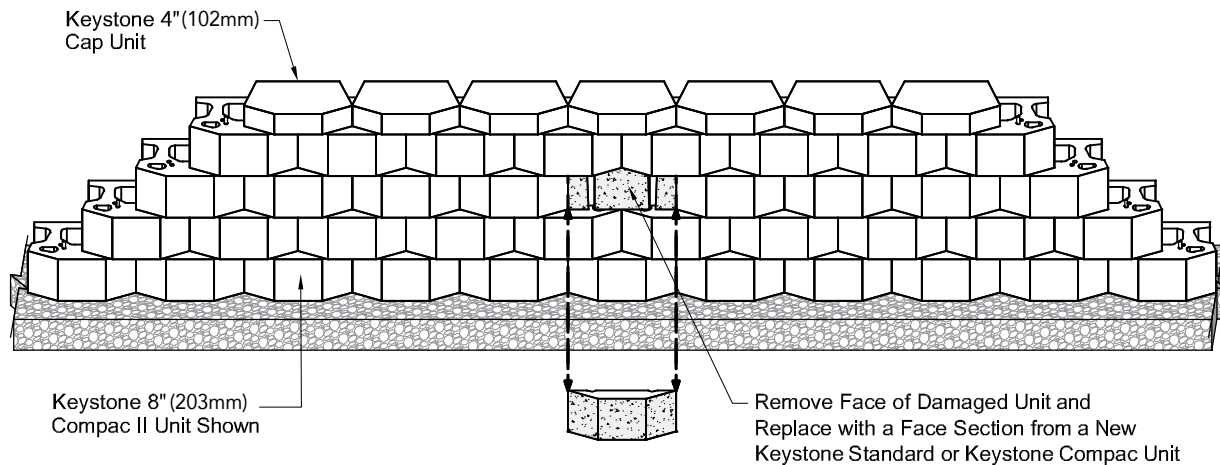
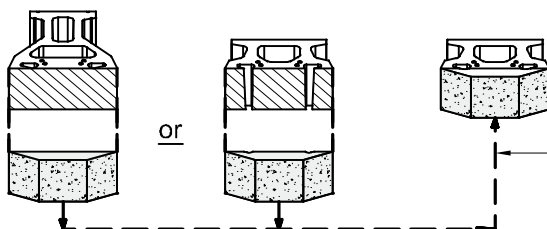


FIGURE E:29- REPLACE UNIT FACE ONLY - FOR TALLER WALLS



Keystone Standard Unit

Keystone Compac Unit



**NOTES:**

Solution allows wall to remain intact. Wall structure with geogrid soil reinforcement is not interrupted.

Cut off face section from a Keystone Standard or Keystone Compac unit for use as a replacement face veneer and insert into removed space provided. Adhere face section to cut unit with exterior grade concrete adhesive.

The information contained herein has been compiled by Keystone Retaining Wall Systems® LLC and to the best of our knowledge, accurately represents the Keystone product use in the applications which are illustrated. Final determination of the suitability for the use contemplated and its manner of use are the sole responsibility of the user. Structural design and analysis shall be performed by a qualified engineer.

FIGURE E:30 - TYPICAL PLANTING LIMITS

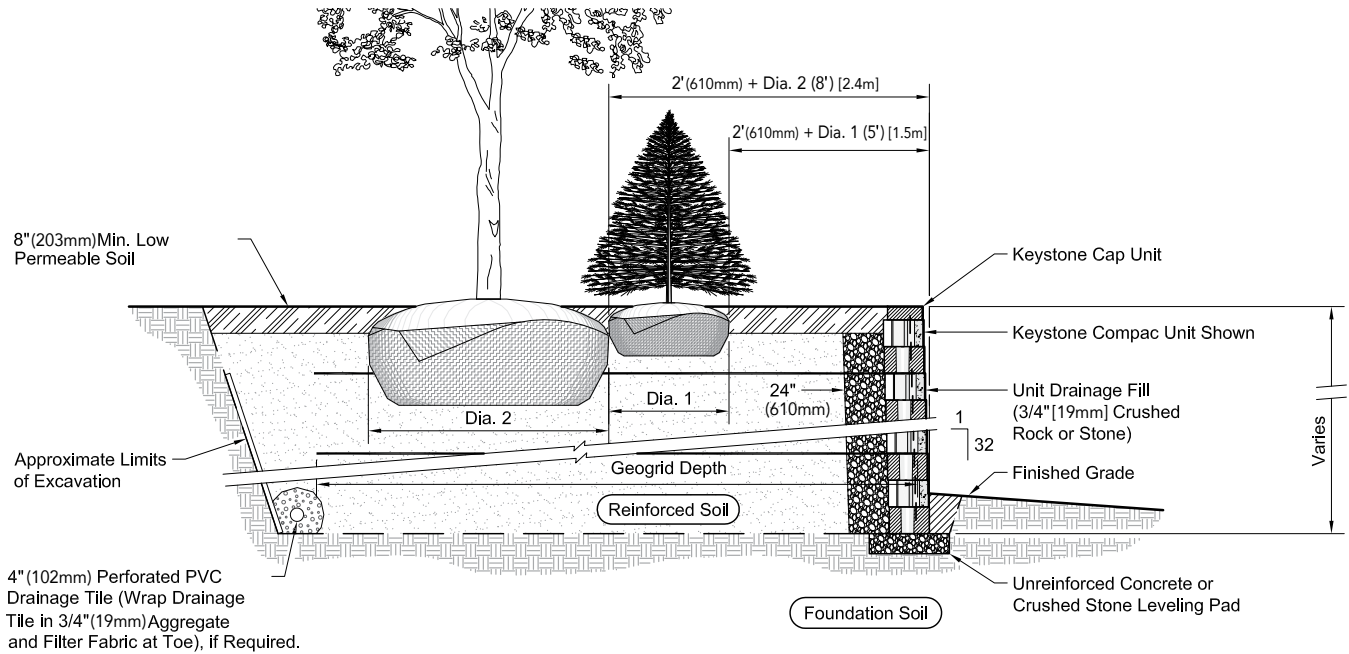
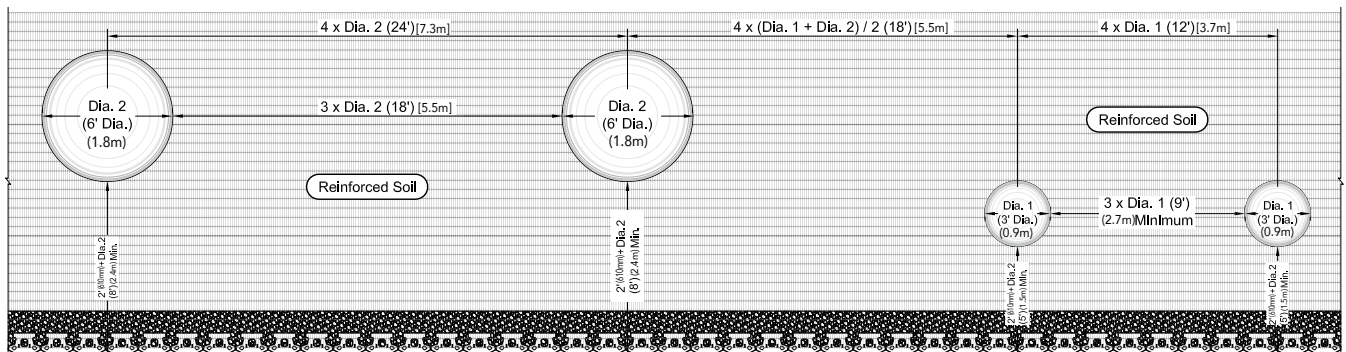


FIGURE E:31 - TYPICAL PLANTING LIMITS



**NOTES:**

- All planting offsets shall be a minimum of 2 feet (610mm) + the root ball opening diameter as measured from face of wall.
- Lateral spacing between openings shall be a minimum of 3 x opening diameter.
- Only top two layers of geogrid may be cut to allow planting of tree ball. Avoid disturbance of adjacent reinforcement.
- If trees are spaced closely together and cutting of geogrid becomes excessive, consult with your Keystone representative.
- Extreme care shall be taken if installing irrigation systems directly behind the wall so as to not damage the soil reinforcement during installation or have potential leakage into the retaining wall system. Leaking irrigation lines can saturate the backfill and create hydrostatic pressure and wall movement.
- Utilize a root control barrier as required to avoid root pressures or growth through the Keystone concrete units.
- Numbers in parenthesis are for example only.

The information contained herein has been compiled by Keystone Retaining Wall Systems® LLC and to the best of our knowledge, accurately represents the Keystone product use in the applications which are illustrated. Final determination of the suitability for the use contemplated and its manner of use are the sole responsibility of the user. Structural design and analysis shall be performed by a qualified engineer.

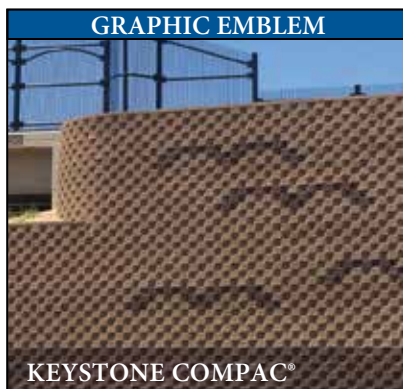
## Creative Options

Add distinctive detail to any Keystone retaining wall. For subtle design accents, vary the texture of units in geometric patterns while maintaining the Keystone unit color choice. Texture combinations can be sculptured tri-plane mixed with straight split units. Dramatic accents can occur when combining units of complementary and/or contrasting color schemes. Consult your local manufacturer/distributor for standard colors, custom color availability, pricing, and unit texture options available by region.

### Additional options:

- » Specific graphic emblem (for example, a logo, state shape, image, etc.).
- » Various bonds (for example, Flemish), diagonal bars, geometric repeats, horizontal bands, stair step bands, etc.

Use these features to coordinate the site landscape retaining walls with accents on building architecture (i.e. belt courses, bands and geometric details).



The information contained herein has been compiled by Keystone Retaining Wall Systems® LLC and to the best of our knowledge, accurately represents the Keystone product use in the applications which are illustrated. Final determination of the suitability for the use contemplated and its manner of use are the sole responsibility of the user. Structural design and analysis shall be performed by a qualified engineer.



# Segmental Retaining Wall Care, Operations and Maintenance Guide

The Segmental Retaining Wall (SRW) is constructed of concrete masonry units, geogrid soil reinforcement fabric, and compacted backfill. The structure's performance is sensitive to any post-construction activities that may damage components, increase loading conditions, and/or reduce overall stability. The following list is intended to provide guidelines for the proper care of an SRW.

1. The area behind the wall that contains geogrid soil reinforcement (reinforced zone) is the primary structural component of the wall system. Do not, under any circumstances, excavate through, drill through, or otherwise damage this reinforcement fabric without written approval of the design engineer of record.
2. The drain line at the base of the wall (if required and installed) should be stubbed out to daylight or for final connection to storm drainage systems by others. Insure that all connections are made to proper drain outlets and that any drain outlets to daylight are not buried.
3. The Keystone wall is normally constructed over a crushed stone base. No digging or excavation shall be done within 3 feet (0.9m) horizontally from bottom face of wall or to such depth that would compromise the integrity of the wall foundation.
4. All water must be diverted away from the base of wall to avoid erosion and undermining of the foundation after installation. This includes temporary site grading during construction and final site grading.
5. Landscape watering and surface drainage above the wall should be designed in consultation with the civil and geotechnical engineer and performed in such a way as to avoid standing water, water cascading over the wall, and infiltration (saturation) of the reinforced zone.
6. Do not increase the height of the existing wall as constructed with more block units without the written approval of the design engineer of record.
7. Do not add a slope or increase the steepness of a back slope beyond what was considered in the original grading plan and wall design without written approval of the design engineer of record.
8. Do not add additional surcharges within a lateral distance of twice the overall height of the structure(s) without written approval of the design engineer of record or unless considered in the original wall design. This would include fences, sound walls, landscaping walls, swimming pools, buildings, garages, etc.
9. Do not operate heavy equipment within four feet of top of wall face. The surcharge from equipment weight can push the upper wall units out resulting in misalignment.
10. Segmental retaining walls are flexible structures (vs. rigid as in CMU walls) and may experience some post-construction movement. All structures (i.e. sidewalks, pavements, curbs, trash enclosures, utility lines, etc.) should be designed to handle some ground movement and not be connected directly to the wall units.
11. The retaining walls should be periodically inspected to verify that drainage measures are functioning properly, and that erosion has not occurred along the top, ends, or bottom of the wall. Any unanticipated movement or deflection of the wall system should be noted and evaluated by a qualified engineer.
12. Over time the wall face may begin to show a white flaky material and may especially be noticeable post-construction. This material is called efflorescence. Efflorescence occurs when moisture evaporates from the wall face, and the naturally occurring soluble salts and bases, or the calcium carbonite (calcium hydroxide in the cement mixes with carbon dioxide in the air) is left on the face. This efflorescence is only an aesthetic concern and will not affect the structural performance of the wall. Efflorescence can typically be removed by dry brushing followed by flushing with clean water. In tougher cases power washing with clean water mixed with muriatic acid solution will also aid in the removal of efflorescence.



Distributed By:

We reserve the right to improve our products and make changes in the specifications and design without notice. The information contained herein has been compiled by KEYSTONE and to the best of our knowledge, accurately represents the KEYSTONE product use in the applications which are illustrated. Final determination of the suitability for the use contemplated and its manner of use are the sole responsibility of the user.



Keystone Retaining Wall Systems LLC  
4444 West 78th Street • Minneapolis, MN 55435  
(952) 897-1040 • [www.keystonewalls.com](http://www.keystonewalls.com)



©2016 Keystone Retaining Wall Systems LLC - Patents Pending • TE-DC16

