



MONTHLY NEWSLETTER | GLENBURN AND LANSFORD | FEBRUARY 2021

# Trinity United Parish

Dear Friends,

In Matthew 11:28-30, Jesus says, “Come to me, all you that are weary and are carrying heavy burdens, and I will give you rest. Take my yoke upon you, and learn from me; for I am gentle and humble in heart, and you will find rest for your souls. For my yoke is easy, and my burden is light (NRSV).”

This is a passage that I seem to come back to time and time again in my life. Jesus says, “Come to me.” Life can feel heavy sometimes, and it can feel like we are carrying the weight of the world on our shoulders. We may feel overwhelmed or stressed or tired but we have this amazing invitation to give it all to Jesus. It is an amazing invitation, but it is easier said than done. I do not know about you, but I often have to pray that Jesus will take my burdens, my worries, my stresses, and more away from me – to rip them out of my hands – because it is so hard for me to just let go and let Jesus have control. Yet, that is what he is inviting us to do – to find rest in him as he guides us in this journey that we are on.

We are so blessed that we never walk this journey of life alone. Jesus walks with us, and he puts other people of faith in our life to walk with us and encourage us along the way. I decided for 2021 I would use a daily devotional book to help me focus at the beginning of each day. I chose, “Jesus Calling” by Sarah Young. I chose this book for a few reasons: 1. It was one of my mom’s favorite devotional books; 2. I already had a copy of it; and 3. It is written as if Jesus is speaking directly to you. I have noticed that, as I have been daily using it, I have been reminded of Jesus presence with me each and every day.

On this day, (the day I’m writing this) the theme was to keep my focus on Jesus. The last line of the devotion really struck me. It said, “I will guard you and keep you in constant Peace, as focus your mind on Me (p.30).” Wouldn’t we all like some peace in our lives? Wouldn’t we all like our daily load to be just a little less? Focusing on Jesus, coming to Jesus will free us and open our hearts and our minds to the peace that only he has to offer.

So, as we continue to move forward into 2021 and into the season of Lent, may focus our hearts and our minds on Jesus, the savior of the world.

Blessings,

Pastor Martha

# Trinity United Parish

PO Box 157, Glenburn, ND 58740

[www.trinityunitedparish.com](http://www.trinityunitedparish.com)

Office: 701-362-7922

Pastor's Cell: 701-833-1701

## Prayer List

For healing and comfort for Elma Doer, the mother of Johnnet Christianson.

For healing for Sonja Mickelson.

For healing for Jenny Undlin.

For Healing for Darren McLean.

For healing for Bob Helming.

For strength for Shay Stevens and family.

For strength and continued healing for Amy Artz.

For healing for Shannon Sisk-Wulick.

For healing Ron Johnston.

For healing and strength for Cole Schlag and Tamara Zumbaum.

## Military

Clay Pilgrim

Bill Tilton

Wes Netcher

Kent Johnson

Nick Swenson

Jesse Hartle

Robert Blevins

Jay Montejo

## Confirmation Worship

### Assignments:

Please make sure you are in worship when you are assigned or find someone to switch with you if you cannot make it.

February 7: LFD: Bobby Zumbaum  
GLB: Gracie Boschert

February 14: LFD: Reid Morlock  
GLB: Jayden Nelson

February 21: LFD: Cole Schlag  
GLB: Caleb Clementich

February 28: LFD: Carson Nett  
GLB: Gracie Boschert



## GLENBURN NEWS

**Confirmation Classes:** Class will be held February 3<sup>rd</sup>, 10<sup>th</sup>, and 24<sup>th</sup>. No Class on the 17<sup>th</sup>. @ 4-5:30pm GLB. Bring your smiling faces and learning spirits!

**Bible Study:** February 4<sup>th</sup>, 11<sup>th</sup>, 18<sup>th</sup>, and 25<sup>th</sup> @ 6:30pm GLB.

**Ruth Circle:** February 16<sup>th</sup> @ 2pm GLB.

**Ash Wednesday Services:** Join us for Ash Wednesday services February 17<sup>th</sup> @ 7pm GLB.

**Midweek Lenten Services:** We will be having our normal midweek Lenten services with all the churches in town. We will kick off the rotation on February 24<sup>th</sup> at 7pm. The midweek service on March 3<sup>rd</sup> will be held at St. Philomena's at 7pm. As of now, no one will be having soup suppers. We will just be having midweek services. We are so grateful to be able to gather together this year for worship, and look forward to next year when we can hopefully add the soup suppers back in. If you have any questions, see Pastor Martha.

**Glenburn Food Pantry:** Our Pantry could use syrup, pancake mix, gravy jelly, peanut butter, Hamburger Helpers, soups of any kind, and toiletries. Any non-perishable food, paper products, and monetary donations are always greatly appreciated. There is a cart in the back of the church. Thanks for donating. We NEED Plastic Bags. Contact Andrea Boschert or Michelle Peters with any questions. Clothes Closet: If you have anything to drop for clothing, please call Michelle Peters at 701-578-4285.

**Food Pantry & Clothing Closet Dates:** Is the 4<sup>th</sup> Wednesday of every month from 6:30-7:30 pm.

**Backpack for Buddies Program:** Is a program that will feed a student in need of food for the weekend. Non-perishable and easy to make foods needed. Examples are: Oatmeal packs, veg. and fruit cups, mac n cheese cups, jellies, tuna packs, ramen noodles granola bars, etc.

If you are interested in sponsoring a child, it costs \$340.00 per year. We currently have 26 students we are helping.

## LANSFORD NEWS

**Confirmation Classes:** Class will be held February 3<sup>rd</sup>, 10<sup>th</sup>, and 24<sup>th</sup>. No Class on the 17<sup>th</sup>. @ 4-5:30pm GLB. Bring your smiling faces and learning spirits!

**Ash Wednesday Services:** Join us for Ash Wednesday services February 17<sup>th</sup> @ 7pm GLB.

## PARISH NEWS

**Ash Wednesday Services:** Join us for Ash Wednesday services February 17<sup>th</sup> @ 7pm GLB.

**Secretary Hours:** Our parish secretary, Ramanda Nash, will be in the office from 12 pm - 3 pm on Tuesdays and Wednesdays, and 10 am - 2 pm on Thursdays. If you need anything from the Church office outside of office hours, please feel free to call or text Pastor at (701) 833-1701.

# Prayer Ventures for February 2021

1 Pray that the Spirit will guide, inspire, and shape the Future Church structure being implemented in the churchwide organization to renew our sense of purpose and activate the entire church so that more people may know the way of Jesus and discover community, justice and love.

2 **Black History Month** Give thanks for the gifts, accomplishments, influence and witness of our African-descent neighbors who stand together with us as partners in the gospel, doing God's work in the world. Though unified as siblings in Christ, we ask God to guide and help our church in its commitment to socioeconomic equity and racial justice and reconciliation.

3 Give thanks for our freedom in Jesus Christ and pray that we might use that freedom to proclaim the glory of God and serve our neighbor in obedience to God's word, will and ways.

4 Pray for the children, youth and family ministry leaders of our church participating in the ELCA Youth Ministry Network Extravaganza, "Holding Loosely." Pray that they will grow and be strengthened for ministry through this time of spiritual renewal, continuing education, networking and mutual support.

5 Pray for ELCA Global Mission and for our ministry of accompaniment with churches, leaders, institutions and companion agencies in Asia and the Pacific region as we work together to grow the church, share the gospel, equip leaders, serve the needs of communities, address issues of development and justice, and assist with disaster preparedness and relief.

6 Ask God to help us listen to each other with respect and to address and heal the political and ideological divisions that discourage us from treating one another with love and concern as neighbors and siblings in Christ. Pray that the Spirit will unite us and lead us in the work we must do together for the well-being of our communities, nation and neighbors in need.

7 Illness, oppression, desperation, and spiritual darkness are no match for the healing and redemptive power of Jesus Christ, the Son of God and our Savior. Praise God!

8 Pray for all those who experience food insecurity across our nation and around the world. Ask God to help us envision how we can work together to bring relief and hope and to address the root causes of hunger and poverty.

9 Give thanks to God for people of all ages, cultures, races, life experiences and perspectives who are new to the ELCA. Pray that, as siblings in Christ, we will nurture and equip one another for participating in God's work in the world.

10 Give thanks and praise to God for God's abundant love, which "heals the brokenhearted, and binds up their wounds."

11 Pray for our outdoor ministry organizations and their leaders as they continue to discern and plan for adapting their ministries during the pandemic — especially as they envision what this summer might bring.

12 Thank God for our special relationship with The Episcopal Church, a full communion partner with the ELCA since 1999. Pray for the church, its members and its leaders, and pray that together we will find strength and new resources for the work of sharing the gospel and serving our neighbor, especially in these uncertain and challenging times.

13 When have you felt proud, boastful, or self-congratulatory for your ministry, witness or service to others? Ask God to forgive you and to refocus your attention on the good news and blessings of grace given to us through Jesus Christ, which we are called to share without bias, hesitation or expectation of recognition or reward.

14 We are not much different from Peter, James or John, who were unsure what they were witnessing when God's glory shined brightly in Jesus during his transfiguration. Pray for patience and for faith in God's promise, that we, too, will someday experience glory and joy in the kingdom of heaven.

15 Pray for our new U.S. president, vice president and members of Congress, that they will find strength, support and unity for their difficult work of serving a diverse nation. Ask the Spirit to help us guide, shape and embolden our culture and nation so that we practice justice, care for our neighbors in need, strive for truth and support our global neighbors.

16 Pray that when people witness our actions and hear our words, they will see the light of the gospel and the love of Jesus Christ in us and will be moved to believe in God's love, forgiveness and actions in the world today.

17 Ash Wednesday Someone tracing the sign of the cross on our forehead with ash speaks to our need for physical reassurance that God has done something special and mysterious in the world through the life, suffering, death and resurrection of Jesus Christ. Speak to God about what this smudge of ash — the cross — means to you and says to people who notice it on your forehead.

18 Ask the Spirit to teach us humility and to remind us that God made us to care for one another, love one another, be generous with what we have and participate in God's good, reconciling work in the world.

19 Pray for families, caregivers and friends who cannot be physically present with hospitalized loved ones. Pray that we will support and comfort them through their time of separation and worry and reassure them of God's very real presence and love.

20 God knows our complexities, vulnerabilities and shortcomings yet still considers us with the wisdom of a fair and merciful judge. With a deep sigh of relief, lift up thanks and praise to God!

21 Renewed, claimed and sent forth through the word and the waters of baptism, we pray that our life in the Spirit will help us resist temptations that draw us away from God and God's ways and will keep us focused on our baptismal journey of faith, learning, service and sharing the good news.

22 Give thanks for everyone involved in the extensive effort to vaccinate people against COVID-19 even as we work to prevent its spread and treat those who are ill. Pray that the hope and the emotional, spiritual and physical stamina of these workers will be sustained for the long haul.

23 Let our prayers and yearnings echo those of the psalmist who wrote, "Make me to know your ways, O Lord; teach me your paths. Lead me in your truth, and teach me, for you are the God of my salvation."

24 Pray that throughout Lent we will reflect on our faith, lives and endeavors with honesty and humility while trusting in God's grace to restore our spirit and to reassure us that we will always be disciples of Christ and loved children of God.

25 Remember in prayer the Deaconess Community of the ELCA. Give thanks and pray for women who respond to God's call to serve as deaconesses and who use their passions, spiritual gifts and education to serve in a wide variety of roles and ministry settings worldwide.

26 Praise God for being patient and loving toward us and for saving us in our desperation and darkness through the suffering, death, and resurrection of Jesus Christ.

27 Pray for the ELCA Young Adult Ministry's work with young adults ages 18 to 30 and for leaders who facilitate young adult ministry in their communities of faith. Pray that young adults will find places in our communities of faith where they belong and ministries both at home and abroad where they can grow in faith,

discern and use their unique gifts and passions, and engage in acts of service, justice and peace in the world.

28 We cannot fully comprehend God's ways or what Jesus has accomplished for our sake and salvation. Pray daily to be alert and receptive to what God is revealing to us and to how the Spirit stirs in us faith, wisdom and understanding.



### **Thank You for Your Generosity**

Our God is a gracious God, who gives abundantly without reservation, and whose generosity so often amazes and surprises us. When we do the same, sharing generously that which God gives us, we are also often amazed at the rich ministry that results. When your congregation shares a portion of your offering with the Western North Dakota Synod it is called "Mission Support". We want to share with you just a few snapshots of how that mission support is used and what your generosity means:

- Lutheran Campus Ministry is alive and well on our college campuses, reaching out to young people while they are away from home. Your offering supports campus ministry at Minot State University.
- congregations are being renewed by digging deep to re-engage mission in their communities and beyond.
  - taking a leap of faith by creating new ministries.
- that support for those from our synod who are preparing for rostered ministry in our church.
  - that you support the education and faith formation of our young people.
- The work of the synod staff is supported: Bishop Craig Schweitzer, Assistants to the Bishop Sherie Heine, Faith Simonieg, and Deacon Beth Anderson, Communications - Carrie Bentley, Financial Specialist - Matthew Nygard, Synod Attorney - Murray Sagsveen, and Administrative Assistant - Shelli Harsche Herman are always sharing the good news of what God is up to in our midst. Your synod staff is there for congregations and their leadership no matter what the need is.

Not only have you provided financial gifts that make such vital ministry possible, but you have also taken seriously the call to discipleship and provided leaders to the synod and the church committees. For this we give thanks.

Faith Simonieg, Assistant to the Bishop for Stewardship and Generosity



---

## A MESSAGE FROM BISHOP CRAIG

February 2021

---

*"Beware of practicing your piety before others in order to be seen by them; for then you have no reward from your Father in heaven." (Matthew 6:1)*

Sisters and brothers in Christ,

Grace and peace to you in the name of our Savior Jesus!

For many of us, the beginning of the sixth chapter in the gospel according to Saint Matthew marks the beginning of a sacred and holy journey through the season of Lent. I must confess, whenever I hear the words "practicing your piety before others" each Ash Wednesday, I giggle a little. Lutherans are not known for our boisterous faith sharing with others.

The Greek word in this verse of scripture speaks of "righteousness" not "piety" in a literal understanding of the word. And, here's the important part, the warning in this verse speaks of the misuse of our own righteousness, how great we are or think we are. Matthew, and the season of Lent, gives us a chance to look deeply into that truth again. Are my actions and behaviors centered on me? Or on God? Lent reorients our life on God.

And when we speak and live out our faith with God's righteousness at the forefront, we, as Lutheran Christians, have something to say. I pray that we are bold enough to say it and not keep it to ourself. As my colleague, Bishop Paul Egensteiner of the Metro New York synod, recently said, "God is calling us to follow the example of Jesus, to live the truth and power of the Gospel, to love all people, and to continue to serve God's children together." In other words, to show others just how awesome and great God is and to worry less about showing others how great we are. May that be central to our Lenten journey this year!

A couple updates from across the synod –

- I continue to welcome invitations to be with your congregation – via Zoom, video, or in-person. I've thoroughly enjoyed getting to know you and celebrate the many ways we share in the ministry God's righteousness is on display across our synod.
- The recent announcement of the closing of Lutheran Social Services of North Dakota was shocking to many across the prairie. We continue to hold all impacted in prayer – most especially the programs, staff, and clients of LSSND. May they be cared for and find hope and renewal in the days ahead.
- The synod offices will also be in a transition very soon. For many years, the synod offices have been in LSSND's Bismarck program center. We are currently looking for a new location for the synod offices. If you have an idea, please reach out to us!
- Synod Council will be meeting in-person or via Zoom on February 19-20. Please hold them in your prayer!
- Thank you for your Mission Support in 2020! Yes, Mission Support was below expectations. BUT – God's righteousness continued to shine through our collective ministry as synod in countless ways. Thank you for being part of this ministry!
- As we continue to navigate all that the world has presented to the church and world in the past year, we give God thanks and praise. It has been a challenging time to be the church in these days. God is with us. And God's righteousness will continue to shine through the church into a world longing to see the reflection of God's goodness being lived out through each one of us.

Serving in Christ together,  
Bishop Craig

---

**Mark Your Calendar: 2021 Synod Assembly  
June 4 & 5 at the Grand Hotel in Minot  
Resolutions must be submitted by March 31, 2021**

---



Psalm 51.10

## Trinity Council Meeting Minutes



January 13, 2021

Present are: Andrea Boschert, Bruce Abernathey, Ken Simmons, Brian Christianson and Pastor Martha HarriSon

- I. Meeting called to order by Ken Simmons at 7:10pm.
- II. Devotions
- III. Secretary's Report
  - a. Minutes provided from the December 2<sup>nd</sup> meeting for review.
    - i. Boschert makes a motion to approve minutes, second by Abernathey. All in favor, motion carries.
- IV. Treasurer's Report
  - a. Copy of ledger provided for review
    - i. Abernathey makes a motion to approve treasurer's report as provided, second by Boschert. All in favor, motion carries.
- V. Pastor's Report
  - a. Report provided for review.
- VI. Committee Reports
  - a. Worship
  - b. Education
    - i. Meeting every Sunday before church.
  - c. Property
    - i. Simmons will get the lift from the school and replace light bulbs and dust area around the projector.
    - ii. Simmons will call Jamee Hansen about helping with some lights that need to be replaced.
  - d. Stewardship
  - e. Evangelism
- VII. Old Business
  - a. Offering Counters
    - i. January 17 – Andrea Boschert
    - ii. January 24 – Ken Simmons
    - iii. January 31 – Bruce Abernathey
    - iv. February 7 – Ken Simmons
  - b. COVID-19 Response/Plan
    - i. Discussion held regarding Ash Wednesday/Lenten Midweek services.
- VIII. New Business
  - a. Annual Meeting Prep
    - i. Council members discussed the proposed annual budget for 2021 based on the expenses year to date.
    - ii. Discussion held regarding council members that will be completing their term.
  - b. Financial Secretary
    - i. Abernathey read a resignation email from Shelly that stated she would like to be done by the end of January 2021.
- IX. Date of Next Meeting – Wednesday February 10<sup>th</sup> at 7:00pm
  - a. Abernathey makes a motion to adjourn meeting, second by Boschert. Meeting adjourned at 8:15pm.

Submitted by: Andrea Boschert



Sunday	Monday	Tuesday	Wednesday	Thursday	Friday	Saturday
	1	2	3 Confirmation 4-5:30pm GLB	4 Bible Study 6:30pm GLB 	5	6
7 LFD Worship 9am  GLB Worship 11am	8	9	10 Confirmation 4-5:30pm GLB  Glenburn Council 7pm	11 Bible Study 6:30pm GLB  	12	13
14 LFD Worship 9am  GLB Worship 11am  Happy Valentine's Day	15   President's Day	16  Ruth Circle 2pm	17 No Confirmation  Ash Wednesday Service Glenburn 7pm	18 Bible Study 6:30pm GLB  	19	20
21 LFD Worship 9am  GLB Worship 11am	22	23	24 Confirmation 4-5:30pm GLB  Midweek Lenten Service GLB 7pm	25 Bible Study 6:30pm GLB  	26	27
28 LFD Worship 9am  GLB Worship 11am						



hello  
February

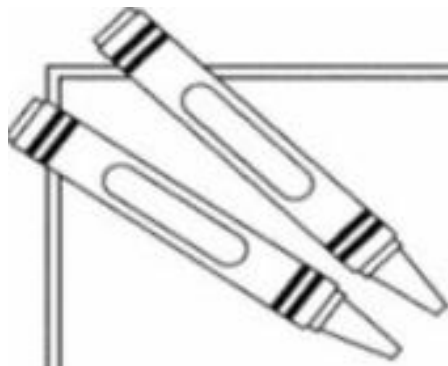

# Just for **KIDS**

Find the correct path through the heart below. Write the words in order, as you find them, on the lines below.

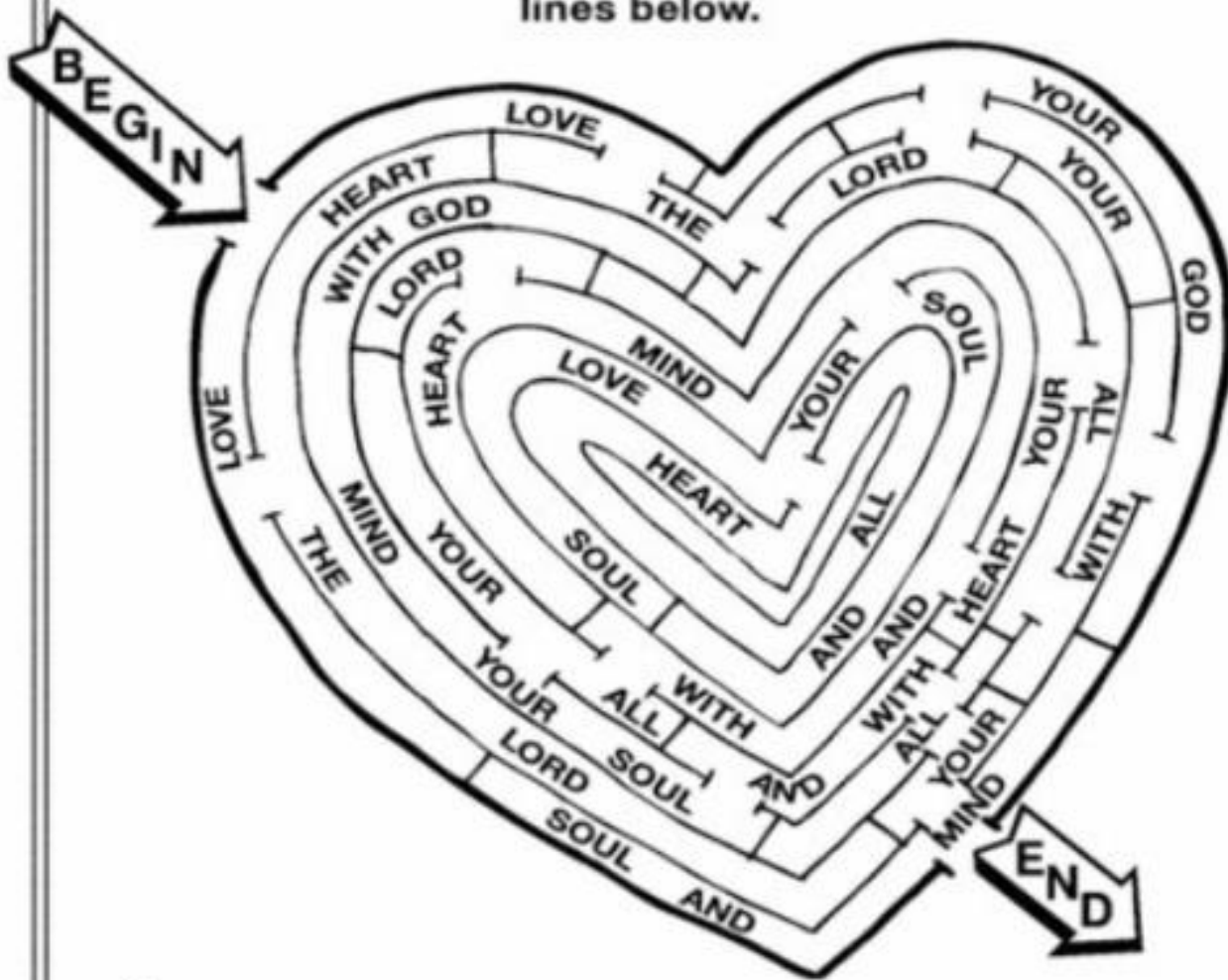

“ \_\_\_\_\_  
\_\_\_\_\_  
\_\_\_\_\_  
\_\_\_\_\_.” Matthew 22:37