

***V*Power 120 – 300 t R**

For flexible assembly injection molding

world of innovation



ERGONOMICAL – FLEXIBLE – HIGHLY EFFICIENT

More productivity through optimal ergonomic design

The advantages of the VPower R

- » Innovative 2-tie-bar rotary table machine concept
- » Reduced footprint compared to predecessor models
- » Servo-driven rotary tables for 2-, 3- and 4-station applications
- » Low, ergonomic working height
- » Injection unit convertible to horizontal or vertical positioning
- » Ultimate mold protection through homogeneous force transmission (UNIFORCE®) in the mold clamping area
- » Easy access to media supply connections below the rotary table
- » Optimal energy efficiency with servo-electric and servo-hydraulic drives
- » Self-explanatory touch screen operation of the UNILOG B8 control system
- » Prepared for conversion into a production cell with the WITTMANN 4.0 "Plug & Produce" integration package

The machine series

VPower R: 3 rotary table diameters – 120 to 300 t clamping force*

*more models and rotary table sizes in planning



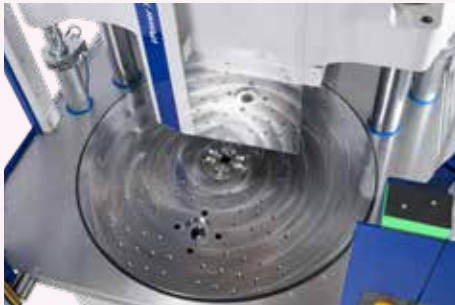
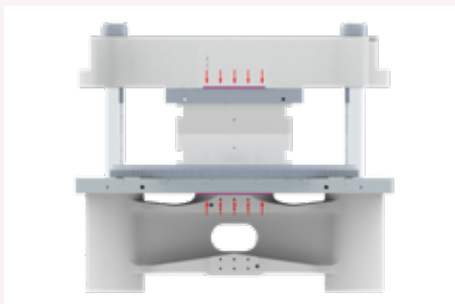
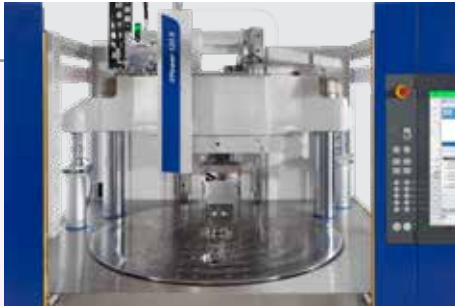

VPower R

The system highlights

- » **Rotary table clamping unit without central tie-bar**
A distinctive feature of the VPower is its optimally accessible rotary table system which, unlike its predecessor model, has dispensed with a central tie-bar in the rotation center. The servo-driven rotary table has been combined with a 2-tie-bar portal clamping unit equipped with two traveling cylinders positioned on the outside for fast opening and closing.
- » **2-tie-bar clamping unit modeled on nature**
The design of the clamping unit has followed a model from nature to make it both rigid and light. The new UNIFORCE® compensation plate system between the horizontal beams and the mold clamping area also provides an unprecedentedly even and gentle force transmission to the mold.
- » **Fast rotary tables**
VPower rotary tables are currently available with diameters of 1300 to 2000 mm and combined with servo-electric drives for short rotation times and high-precision positioning. A central lubrication system for all moving parts and seals to prevent penetration of liquids or particles provides highest possible operational safety.
- » **Media supply connection points at the rotary table center**
The tie-bar-less rotation center provides ample space for the installation of cooling water, hydraulic oil, compressed air and power supply connections under the rotary table. The connections to the molds can be led through the center of the rotary table either via direct tubing or via an oscillating or rotary distributor.
- » **General convertibility from H to V injection and vice versa**
The modular VPower concept consisting of clamping units of variable sizes and a compact drive model across all sizes is the prerequisite for a minimal footprint. The installation points for the injection units are designed to enable easy conversion of the injection unit from horizontal to vertical configuration and vice versa.

VPower R CLAMPING UNIT

Top scores for ergonomics and force distribution

The clamping system of the VPower machine series has incorporated in its technology proven, stress-optimized design elements from nature. It takes the form of a 2-tie-bar portal system offering well-balanced force transmission combined with light weight. The movements are carried out via two low-volume fast-stroking cylinders, while the clamping force is applied via two pulling high-pressure cylinders inside the frame base and the crosshead.

NEW: UNIFORCE® compensation plate system for maximum mold protection

A new feature is a UNIFORCE® compensation plate system between the frame crosshead and the mold platen, which neutralizes the flexural deformation effect on the clamping area, caused by the force transmission, thus ensuring a so far unparalleled, even force distribution on the mold to reduce wear.

The advantages

- » Ample space and symmetrical force distribution
- » Symmetrical and evenly distributed force transmission across the clamping area ensures maximum protection of the molds.
- » Deformation of the rotary table and the mold platens reduced to a minimum

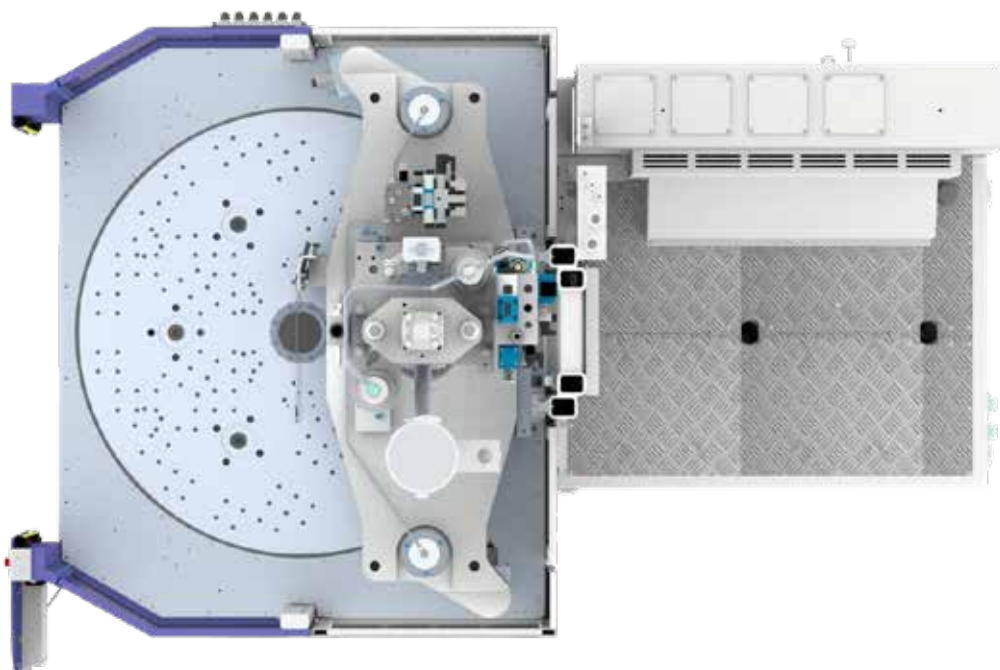
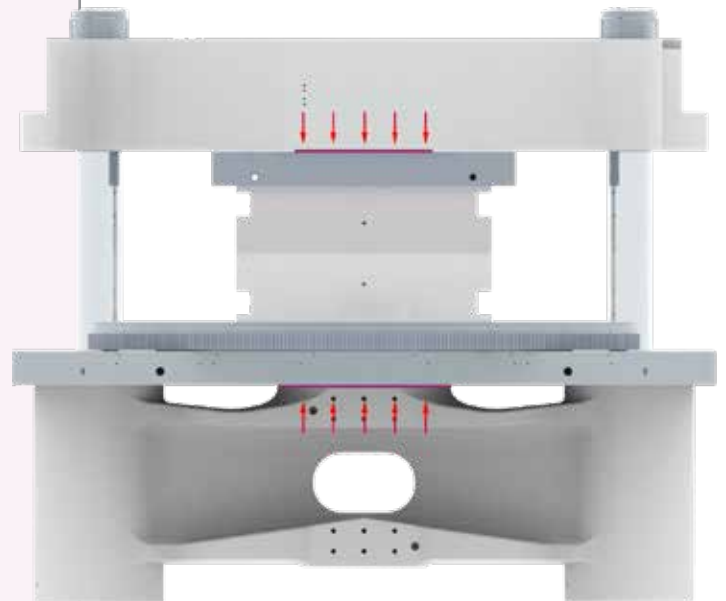

ROTARY TABLES

Fast and precise

Wittmann



- » All rotary tables are equipped with servo drives for short rotation times.
- » Available for either oscillating 2-station operation or rotating 2-, 3- or 4-station operation
- » Precise positioning through electronic rotation angle control
- » Dynamic, highly accurate end position control
- » End position definition through indexing
- » Low height and thus overall ergonomically favorable working height of the clamping unit
- » All rotary tables come with a central opening for insertion of cable and/or tube connections (only for oscillating operation), or a rotating conduit for media connections.
- » Rotary union for up to 9 media circuits (temperature control, pneumatics, hydraulics) as well as power circuits and sensors are available on an optional basis.
- » Central greasing for bearings, gears and low-friction sliding areas
- » Fully sealed circumference of the rotary table to prevent penetration of liquids and particles

Extension options

- » Additional media circuits
- » Customized ejector positioning
- » Installation of magnetic mold platens
- » Data transmission modules



INJECTION UNIT

Versatile horizontal – vertical

Proven plasticizing technology

- » All screws from 25 mm upwards come with a 22:1 L/D ratio.
- » All injection aggregates offer a wide range of injection pressures (from 3000 bar for the smallest and up to about 1600 bar for the largest screw diameters).
- » Moment-free nozzle contact through axial positioning of the traveling cylinders for the plasticizing aggregate
- » Barrels can be inserted into different injection aggregates when the screw diameter is identical.
- » Easy access to the nozzle thanks to diagonally arranged traveling cylinders for the nozzle
- » 650 mm nozzle stroke for easy removal of the barrel
- » Electrical height-adjustable horizontal injection unit with path measurement system and easy nozzle centering
- » Aggregate support via linear guides
- » Integrated injection block close to the injection unit
- » Aggregate in V configuration free of obstruction by structural components at the front (hopper on the right), thus minimal risk of collision with automation equipment
- » In combination with the WITTMANN BATTENFELD HiQ software modules (optional), sensitive adjustment strategies are available for compensation of external influencing factors such as temperature, moisture content, proportion of regrind or Masterbatch.



Anti-wear options

In addition to the high-quality standard finish, an extensive range of optional versions with extra anti-wear and/or anti-corrosion protection is available. Pre-defined option packages and a selection matrix facilitate the choice of the right version.

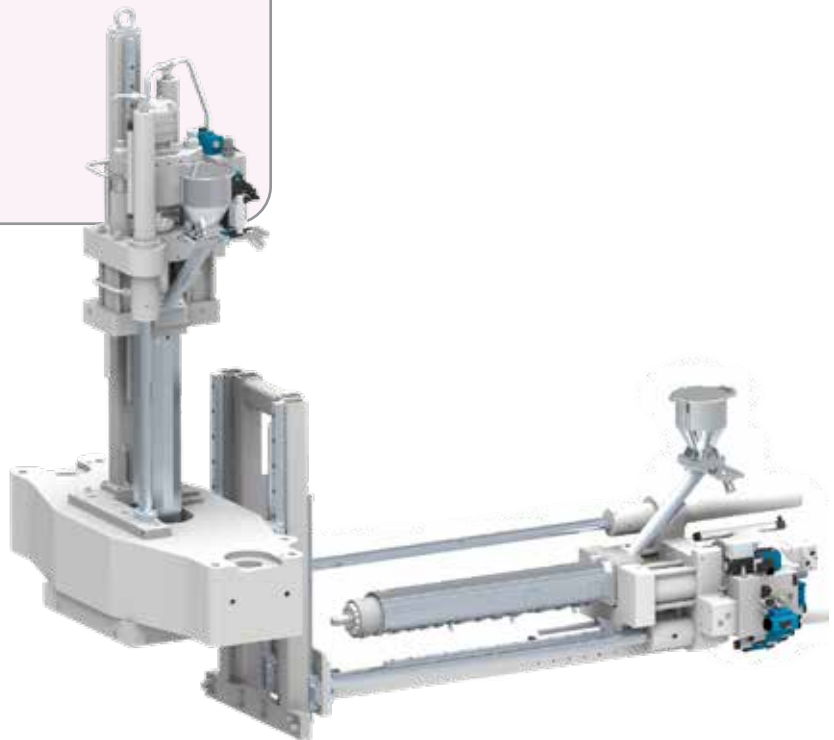

INJECTION UNIT

Flexibly horizontal or vertical

Wittmann

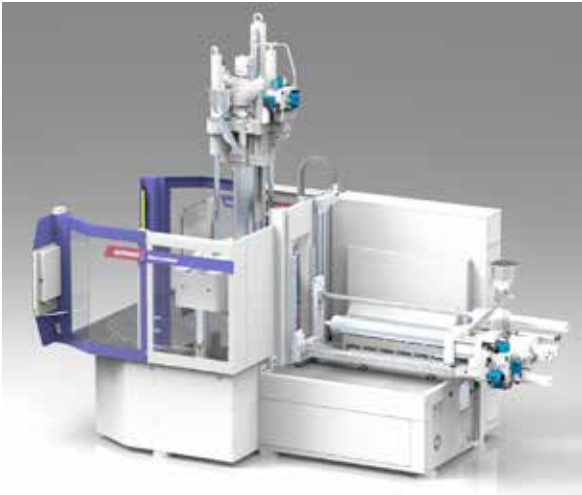

Versatile convertibility between H and V injection

The clamping units in various sizes are combined with a compact drive module consisting of a frame which houses hydraulic pumps and servo-electric drives and an electric control cabinet. This combination facilitates a minimal footprint.

The installation points for the injection units are designed to enable quick and easy conversion from horizontal to vertical configuration and vice versa, for example to meet varying production requirements. Of course, 2- or 3-color versions with two or three injection units are also available.

Retrofitting of second injection unit possible

The machine's drive system is laid out for operation with one injection unit as standard. But the *VPower R* can also be ordered ex works with the extension option for operation with 2 aggregates for 2-component injection molding. This enables easy retrofitting of the second plasticizing unit within a very short time.

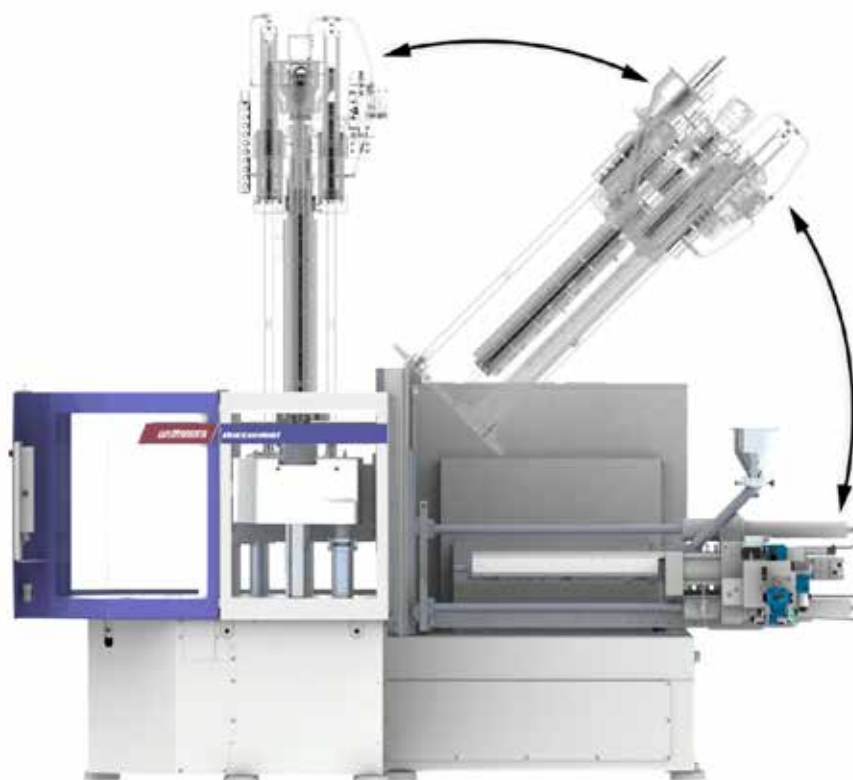

DRIVE TECHNOLOGY

Energy efficiency through "Drive-on-Demand"

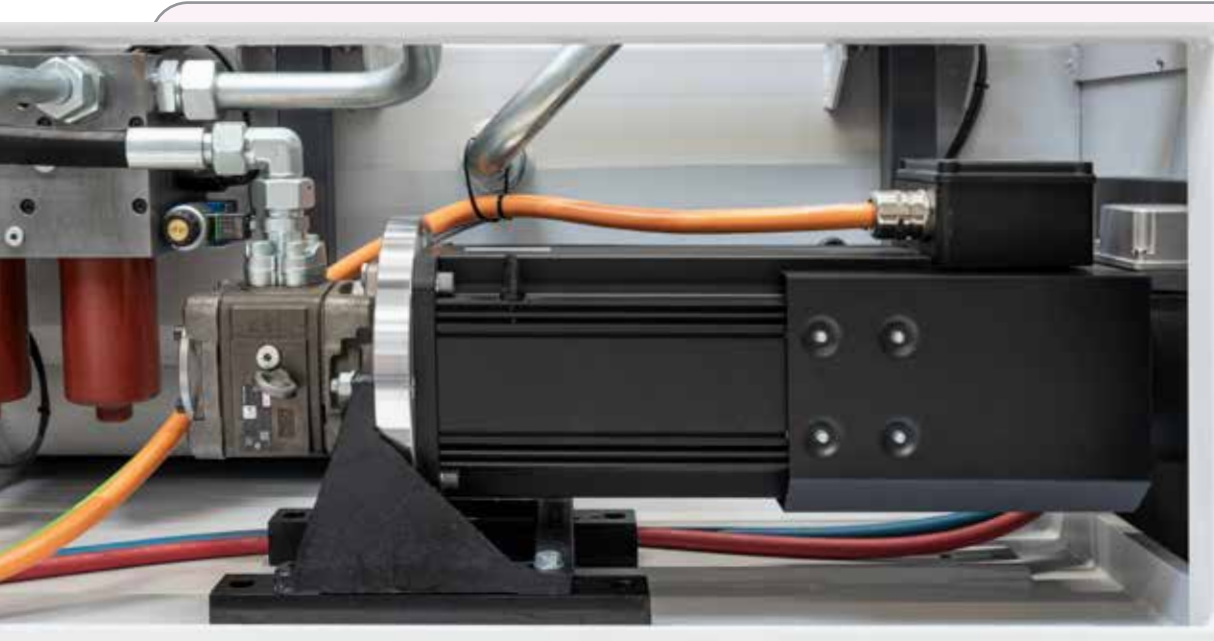

Responsive, precise, thrifty

"Drive-on-Demand" is the innovative combination consisting of a responsive, speed-controlled, air-cooled servo motor and a fixed displacement pump. This drive unit is only activated when required for movements and pressure generation. During cooling periods or cycle breaks for parts handling, the servo drive is switched off and consumes no energy. During operation, "Drive-on-Demand" is the basis for highly dynamic, controlled machine movements and short cycle times.

As in the *SmartPower* machine series, the "Drive-on-Demand" system is also installed in the *VPower* machines as standard, which means that this series already complies with the EU Energy Efficiency Directive today.

The Highlights

- » The *VPower* is equipped with a servo-hydraulic twin pump system as standard, to enable parallel movements of the opening and ejector strokes.
- » Through encapsulation and sound insulation of the motor/pump compartment, the drive unit features extremely low noise emission (65 dBa).
- » The highly effective fine filtration of the hydraulic oil in the main flow channel ensures long-term high precision.

VPower PRODUCTION CELL

With WITTMANN automation

Wittmann

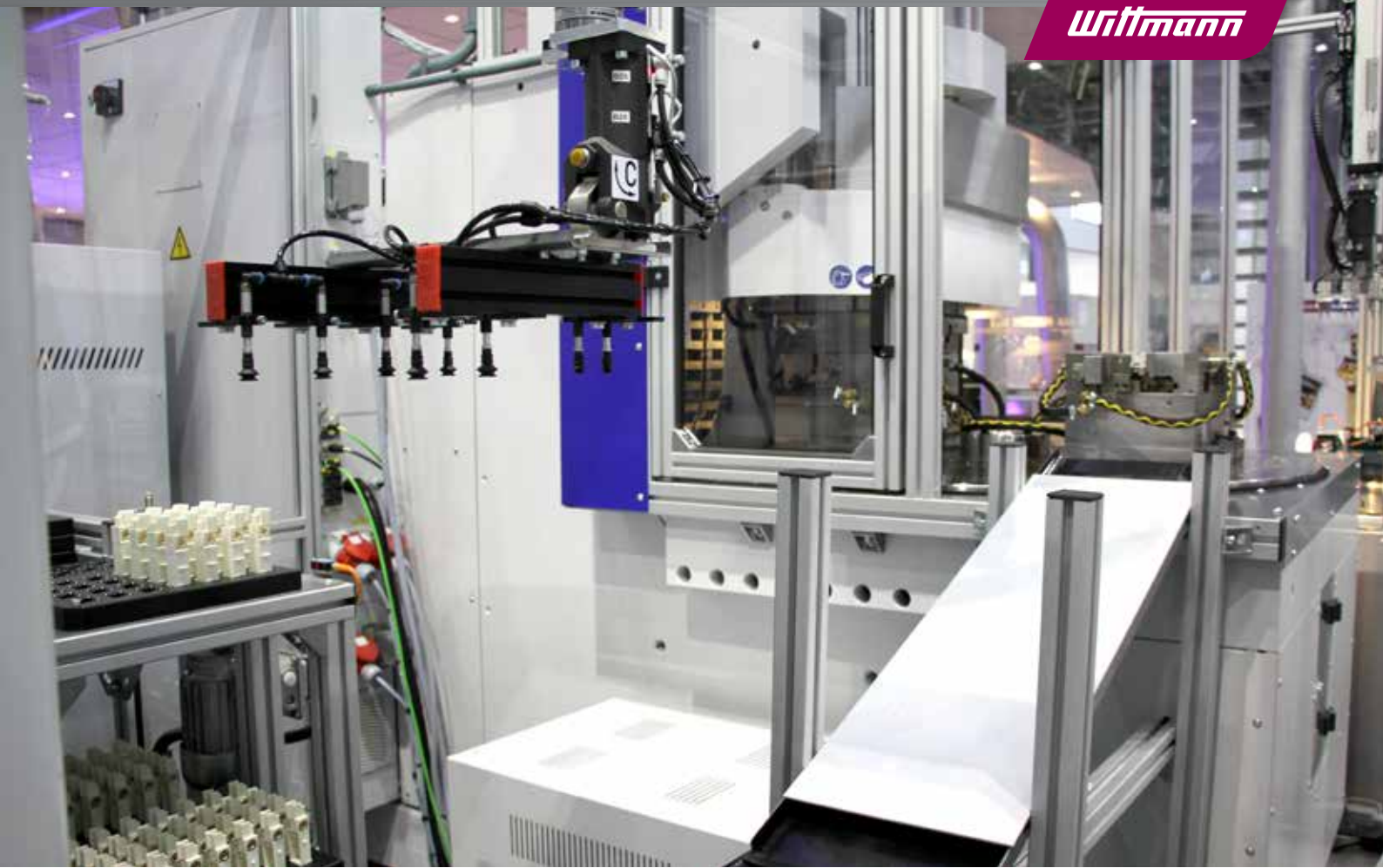

The efficiency of assembly injection molding is largely determined by the efficiency of insert handling. Thanks to their fundamentally re-designed clamping unit, VPower injection molding machines offer an unprecedented level of accessibility and ergonomic operation. This facilitates and increases productivity in parts handling by operating staff and reduces the necessary expense for connection of handling robots.

Many years of automation expertise

With its extensive product portfolio of auxiliary equipment and injection molding machines, WITTMANN BATTENFELD is able to supply from its own resources seamlessly integrated production cells consisting of an injection molding machine, handling automation and auxiliaries. WITTMANN BATTENFELD can also draw on decades of experience in injection molding automation.

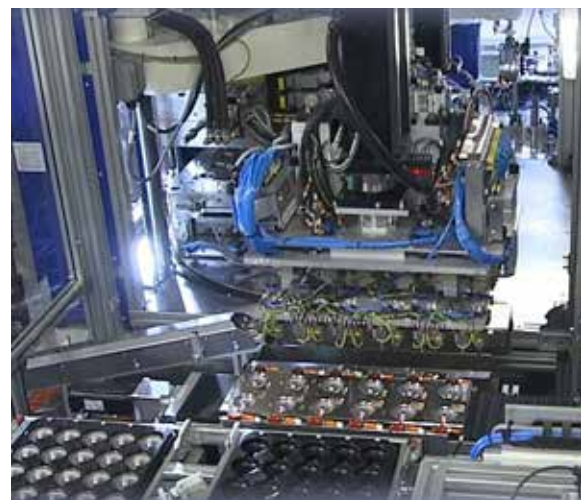

UNILOG B8

Complex matters simplified

The UNILOG B8 machine control system is the WITTMANN BATTENFELD solution to facilitate the operation of complex processes for human operators. For this purpose, the integrated industrial PC has been equipped with an enlarged intuitive touch screen operator terminal. The visualization screen is the interface to the new Windows® 10 IoT operating system, which offers extensive process control functions. Next to the pivotable monitor screen, a connected panel/handset is mounted on the machine's central console.



UNILOG B8

Highlights

- » **Operating logic**
with a high degree of self-explanation, similar to modern communication devices
- » **2 major operating principles**
 - Operating/movement functions via tactile keys
 - Process functions on touch screen (access via RFID, key card or key ring)
- » **Process visualization**
via 21.5" touch screen display (full HD), pivoting laterally
- » **New screen functions**
 - Uniform layout for all WITTMANN appliances
 - Recognition of gestures (wiping and zooming by finger movements)
 - Container function – split screen for sub-functions and programs
- » **Status visualization**
Uniform signaling system across the entire WITTMANN Group
 - Headline on the screen with colored status bars and pop-up menus
 - ambiLED display on machine
- » **Operator assistance**
 - *QuickSetup*: process parameter setting assistant using an integrated material database and a simple query system to retrieve molded part data with machine settings pre-selection
 - Extensive help library integrated

The process in constant view

Wittmann

» **SmartEdit**

SmartEdit is a visual, icon-based cycle sequence programming facility, which enables direct addition of special functions (core pulls, air valves, etc.) based on a standard process via touch operation on the screen. In this way, a total user-defined sequence can be compiled from a sequence menu. This machine cycle, visualized either horizontally or vertically, can be adjusted simply and flexibly to the process requirements by finger touch with "drag & drop" movements.

The advantages

- Icon visualization ensures clarity.
- Clear events sequence through node diagram
- Alterations without consequences through "dry test runs"
- Theoretical process sequence can be quickly implemented in practice.
- Automatic calculation of the automation sequence based on the actual set-up data set without machine movements

» **SmartScreen**

- Partitioning of screen displays to visualize and operate two different functions simultaneously (e.g. machines and auxiliaries)
- Uniform design of the screen pages within the WITTMANN Group
- Max. 3 containers can be addressed simultaneously for the *SmartScreen* function.
- Adjustments of set values can be effected directly in the set value profile.

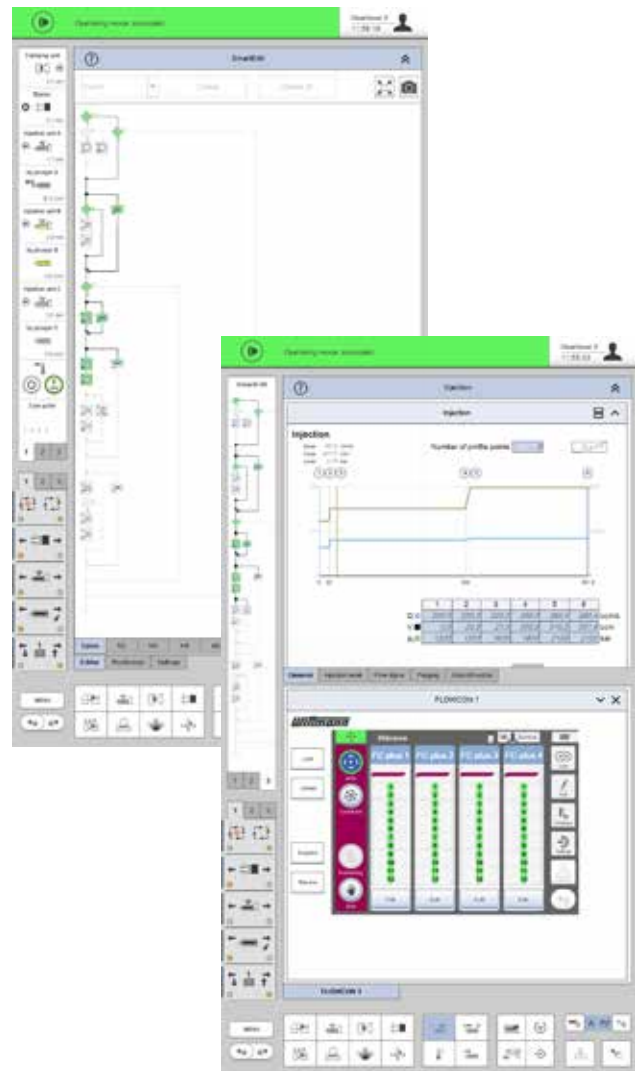

Remote communication

» **QuickLook**

- Production status check via smartphone – simple and comfortable:
- Production data and statuses of all essential appliances in a production cell
 - Complete overview of the most important production parameters
 - Access to production data, error signals and user-defined data
 - The production cell overview offers a clear, simple overview of the production cell's general condition and that of its individual WITTMANN 4.0 appliances.

» **Global online service network**

- Web-Service 24/7: direct Internet connection to WITTMANN BATTENFELD service
- Web-Training: efficient staff training by means of the virtual training center

WITTMANN 4.0

Communication in and with production cells

With its communication standard WITTMANN 4.0, the WITTMANN Group offers a uniform data transfer platform between injection molding machines and auxiliary equipment from WITTMANN. In case of an appliance change, the corresponding visualizations and settings are loaded automatically via an update function, following the principle of "Plug & Produce".

Connection of auxiliary via WITTMANN 4.0

- » **WITTMANN FLOWCON plus water flow regulator, GRAVIMAX blenders and ATON dryers**
 - Units directly addressed and controlled via the machine's control system
 - Joint saving of data in the production cell, the machine and in the network via MES
- » **WITTMANN robots with R8 control system**
 - Operation of robots via the machine's monitor screen
 - High-speed communication between machine and robot to synchronize movements
 - Important machine movements can be set via the R8 robot control system
- » **WITTMANN TEMPRO plus D temperature controllers**
 - Setting and control of temperatures via the machine's control system possible
 - All functions can be operated either on the unit or via the machine's control system

Integration in MES system

The integration of machines and complete production cells in an MES system is a prerequisite for an efficient and transparent production facility according to the Industry 4.0 concept.

Depending on customers' requirements, small and medium-sized companies as well as global players are offered a compact MES solution based on TEMI+. With the Windows® 10 IoT operating system, it is also possible to have selected status information from all connected machines on the production floor shown under *Smart-Monitoring* on the display screen of every machine.

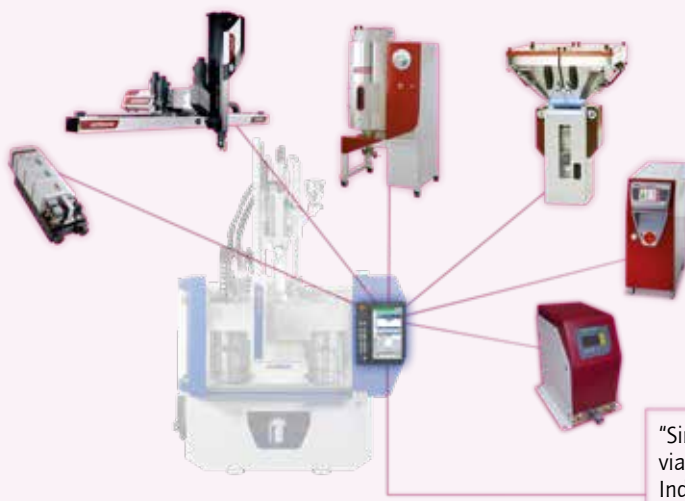

WITTMANN 4.0 system
With WITTMANN 4.0, a machine and its robots and auxiliaries are transformed into a uniform technical organism, which communicates externally via a specific IP address. Such a "Single point entry" with an integrated internal firewall substantially increases cyber security.

OPTIONEN

Modular and flexible

Wittmann

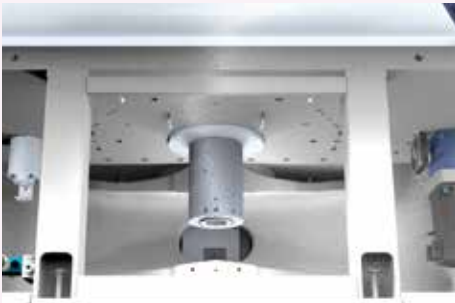
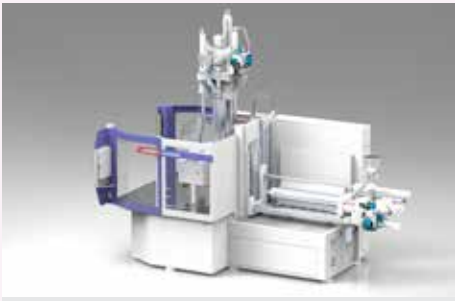

VPower

The optional highlights

- » **Servo-electric plasticizing**
As an alternative to the standard hydro motor drive for the rotation of the screw, a direct drive powered by a servo motor is available as an option. It reduces energy consumption and also offers extended scope for parallel operation of the clamping and plasticizing units.
- » **2-component machine**
The drive unit of the VPower provides the basic prerequisites for operation with 2 aggregates. If the machine has been prepared for the 2-component operation, it can either be ordered as a 2-component injection molding machine ex works, or be retrofitted with a second plasticizing unit later.
- » **Media distributor rotary operation**
Rotary union distributing various media and electrical signals are available for 3- and 4-station rotary table machines. This type of media distributor offers numerous adjustment options for the hydraulic and pneumatic systems, air supply connections and electrical signals.
- » **Pivotable control terminal**
For the installation and set-up of complex molds on the rotary table, it is of advantage for the machine operator to keep the molds in view while programming the control system. For this purpose, a pivotable and rotatable control terminal is available as an option instead of the standard fixed terminal.
- » **Auxiliaries from WITTMANN**
The extensive range of WITTMANN auxiliary appliances offers suitable solutions for all secondary processes of injection molding, from parts handling, material transport and material drying to sprue recycling and mold cooling. With the optional WITTMANN 4.0 integration package, all additional appliances can be integrated into the production cell according to the "Plug & Produce" principle.

APPLICATION TECHNOLOGY

Competence above standard

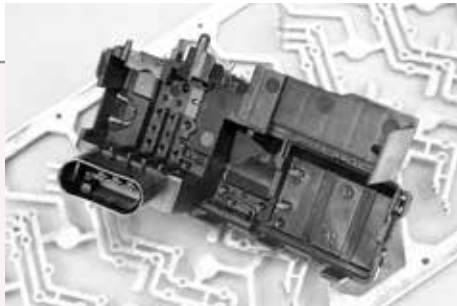

Photo: WITTE Automotive

» Insert molding of complex electrical structures

Embedding complex conductor tracks in plastic is a traditional assembly molding task. The metal structures are centered inside the mold by retractable fixing pins. Towards the end of the injection process, the pins are pulled back via the core pull function and the remaining holes are filled.



» Metal/plastic assembly injection molding

Another traditional assembly application is insert molding of metal bushing or threaded inserts. Through insert molding, a positive-locking connection is created which is normally superior to downstream joining by ultrasound or hot pressing.



Photo: WEIDMANN PLASTICS TECHNOLOGY AG

» Combinations of plastic with plastic

Assembly injection molding is not limited to combinations of plastic with metal, but can also be realized by insert molding of a prefabricated plastic part.



Photo: Promotech

» Multi-component addition injection molding

Application example for the assembly of a molded part through sequential addition of plastic components in consecutive injection molding stations, as illustrated here by an automobile rain sensor part consisting of 4 components.

TECHNICAL DATA *VPower*

Wittmann



COMBINATIONS

Clamping unit	Rotary table	Injection unit						
		130	210	350	525	750	1000	1330
t	mm							
120 R	1300	•	•	•	•			
120 R	1600	•	•	•	•			
160 R	1300		•	•	•	•	•	
160 R	1600		•	•	•	•	•	
220 R	1600			•	•	•	•	
220 R	2000			•	•	•	•	
300 R	2000				•	•	•	•

Material	Factor
ABS	0.88
CA	1.02
CAB	0.97
PA	0.91
PC	0.97
PE	0.71
PMMA	0.94
POM	1.15
PP	0.73

The maximum shotweights (g) are calculated by multiplying the theoretical shot volume (cm³) by the above factor.

Material	Factor
PP + 20 % Talc	0.85
PP + 40 % Talc	0.98
PP + 20 % GF	0.85
PS	0.91
PVC hard	1.12
PVC soft	1.02
SAN	0.88
SB	0.88
PF	1.3
UP	1.6

Dark grey boxes = thermosets

STANDARD

Base machine

Drop - voltage 230/400 V/3p+N-TN/TT, 50 Hz

Painting RAL 7047 tele grey 4 / RAL 5002 ultramarine blue

Air cooling system for drive unit, water cooling for feeding zone and oil cooler with solenoid valve

Test-run with hydraulic oil HLP32 zinc free according to DIN 51524 T2 / purity level 17/15/12 according to ISO 4406 (attention: oils are not included in delivery), lubricants according to H2 quality

Printed operating manual incl. user manual on USB flash drive in any EU language acc. to definition of country incl. type examination certificate TÜV Austria in German incl. protocol: electrical safety acc. to EN 60204-1

Injection molding machine according to machinery directive 2006/42/EG incl. declaration of conformity and CE-marking

Hydraulics

Drive unit S0 with speed controlled servo motor for hydraulic pump to increase the energy efficiency incl. add. pump with speed-controlled servo motor for indexing the rotary table, core pull movement or parall. ejection

Hydraulics with oil cooler controlled in water inlet of cooling, oil level

Monitoring, oil filtration with electrical clogging indicator

Oil preheating of hydraulic drive

Clamping unit

Clamping force and closing and opening forces adjustable

Mold safety program

Exact platen parallelism with low-friction linear guides.

Mold platen according to EUROMAP 2, clamping surface metallic bright, rest painted

Rotary table servo motor drive for 2 stations, oscillating 180°, rotary speed adjustable via touch screen

Final positioning by means of the hydraulic index cylinder

Stainless steel cladding of rotary table

Rotary table on sliding plates: PTFE sliding surface

Central lubrication for rotary table sliding plates and gear ring

Hydr. ejector in operating position, adjustable via several ejector programs

Clamping cylinder plunger induction hardened and hard chrome-plated, ejector piston hard chrome-plated, position sensor contactless

Pneumatic mold safety mechanism with electr. monitoring

Pre-selection of active mold lower parts (1 or 2) for production process

Injection unit

Horizontal or vertical injection unit

Horizontal injection unit offers automatic height adjustability

Splash guard

Hydraulic screw drive

Injection, holding and back press. contr. with defined nozzle carriage press.

Plasticizing unit AK+, L/D=22, 3-zone universal screw, 3-parts check valve, heater bands up to 350 °C w/o insulation

Thermocouple failure monitor

Maximum temperature supervision

Plug-in ceramic heater bands

Temperature control of feed throat integrated

Injection cylinder plunger hard chrome-plated and position sensor contactless

Selectable barrel stand-by temperature

Decompression before and/or after metering

Physical units - bar, ccm, mm/s etc.

Screw protection

Auxiliaries screw speed indication

Linear interpolation of holding pressure set values

Bar chart for barrel temperature with set value and actual value display

Selectable injection pressure limitation

Changeover from inject. to holding pressure dep. on stroke, time & pressure

Open nozzle R35

Splash guard and barrel covering in standard execution according to EN201, L/D 22 protected via transporter switch

Material hopper 6 l (MH206) for automatic material feed, sliding device with shut-off function for material with sliding guide

Safety gate

Covering injection side - maintenance door screwed together

Safety gate with maintenance door left, right and behind electr. and hydr. monitors, plexiglas transparent 309 / frame RAL 5002 ultramarine blue

Infrared light curtain in operating station

Electrics

Control zone for nozzle heater band 230 V

ambiLED-status indicator

Fuse protection for sockets

Switch cabinet cooling - circ. fan for environment temperature to 30 °C

Emergency stop switch button

Printer socket

USB - 1 x operating unit

1 Ethernet interface (switch cabinet)

Printer via USB connection or network

Control system

Control system UNILOG B8 - 21,5" multi-touch screen (full HD)

Pivotable control panel with selectable haptic keys

Software for operating hours counter

Closing/Opening - 5 profile steps

Ejection - 3 profile steps

Nozzle forward/back - 3 profile steps

Injection/Holding pressure - 10 profile steps

Screw speed/Back pressure - 6 profile steps

Parts counter with good/bad part evaluation

Purging program through open mold, 2-station application

Stroke zero offset settings

Start-up program

Switchover to holding pressure MASTER/SLAVE by injection time, screw stroke/injection volume and injection pressure

Self-teaching temperature controller

Display of temperature inside electrical cabinet

Seven-day timer

Access authorization via USB interface, password system and RFID authorization system (1 x check card IT-level-15, 1 x token customer level-30 and 1 x token customer service level-20 are included in delivery)

Freely configurable status bar

Physical, process-related units

Automatic dimming

Logbook with filter function

User programming system (APS)

Userpage and note pad function

Cycle time analysis

Hardcopy function

Internal data storage via USB connection or network

Online language selection and online selection of imperial or metric units

Time monitoring

BASIC Quality Monitoring (1 freely configurable network connection, quality table with 1000 storage depth, events protocol (logbook) for 1000 events, actual value graphics with 5 curves, 1 envel. curves monitoring)

Injection, metering and demolding integral supervision

Alarm message via e-mail

QuickSetup - assistance program for initial parameter setting

Energy consumption monitoring for motors and heating

Dynamic visualization of the mold table, mold, injection, insert and removal status as well as mold configuration

Preselection of single or multiple insert or removal processes

Base machine

Regional packages, country-specific
 Special voltages
 Special varnishing
 Handlingpack. with parted safety gate and/or. deactiv. light curtain
 Parts chute for separation of good/bad parts or photoelectric ejection check

Hydraulics/Pneumatics

Drive unit S2 with speed controlled servo motor for hydr. pump incl. add. pump for core pull movement, parall. ejection and rapid injection
 Hydraulics with increased oil cooler
 Raw filter in water inlet of cooling incl. adapter with ball valve for oil maintenance on oil tank w/o bypass filter unit
 Hydraulic core pull for clamping plate, interface according to EUROMAP 13, incl. or without core pull pressure release
 Pneum. core pull and air valves on clamping plate/rotary table, incl. pressure regulator
 Hydraulic manifolds for one mold shut-off nozzle or more
 Compressed air pressure maintenance unit incl. 1 or more way pressure regulation incl. directional exhaust valve with blocking function
 Vacuum equipment on clamping plate/rotary table

Clamping unit

Mold platen according to SPI, JIS, T-slots
 Mold platen incl. cooling channels and temperature regulation
 Rotary table for 3 and 4 station application 120° or 90°
 Mold platen/rotary table chemically nickel-plated
 Mold installation dimension on customer request
 Hydraulic ejector replaceable, 3 and 4 station application
 Add. hydraulic ejector on clamping platen
 Double check valve to keep ejector in end-position
 Electric ejector with holding brake
 Ejector cross according to EUROMAP/SPI
 Mechanical or pneumatic ejector coupling
 Ejector platen safety
 Ejector back up while in two-hand operation

Injection unit

Injection unit convertible (H/V) for alternative operation
 High torque hydraulic screw drive/high revolution hydraulic screw drive
 Screw drive by servo motor for parallel recovery
 Injection, holding and back pressure controlled via servo valve
 Check valve to hold screw in position after end of dosing
 Corrosion resistance injection unit
 Plasticizing unit AK+, AK++, AKCN, AKTN
 Barrier section, screw with mixing section w/o grooves
 Ball type screw tip
 Melt pressure transducer, melt temperature sensor
 Heater bands up to 450 °C
 Special plasticizing unit for LIM, MIM, CIM, Duroplast, PVC
 Barrel insulation
 Open nozzles in special execution
 Open AIRMOULD®-nozzles
 Needle type shut-off nozzle operated with spring, pneumatically or hydraulically
 Barrel covering and splash guard in special execution
 Pneum. purging guard for H- and V-injection unit
 Purging function via open mold on customer request incl. purging tray w/o monitoring
 Material hopper in special execution w/o pneum. shut and emptying function w/o magnet in material hopper
 Unifeed
 Mixing and dosing units
 Vacuum package incl. vacuum pump

Safety gate

Extended execution for manual part removal
 Add. light curtain for clamping unit or 3rd operation station protection
 Special protection cage for the construction of automation systems incl. required mechanical and electrical interfaces

Cooling

Manual cooling water distributor, flow and temperatur monitoring or with flow control, with/without blow-off valve
 Solenoid valve for cooling water distributor
 Machine cooling by T-piece in inlet pipe
 Filter back flushable/water pressure supervision in inlet pipe
 Distributor block on rotary table/clamping plate with/without insulation
 Rotary distributor for conditioning, hydr. and pneum. for rotary application, w/o electr. signal transmission, contactless, w/o slipping transmission up to 10 A power section

Electrics

Temperature control zones for hot runner
 Acoustic element integrated in signal lamp
 Socket combination
 Add. fan in electr. switch cabinet for increased environment temperature
 Cabinet air conditioner
 Additional emergency stop switch button
 Interface for robot, conveyor belt, TCU, dosing unit, AIRMOULD®, BFMOLD®, mold surveillance, production data logging system, RJG eDart, Priamus BlueLine, danger zone boundary, ejection in mold middle plate, brushing device, relay signals

Control system

Cavity pressure switchover
 BNC sockets for injection process analysis
 EXPERT Quality Monitoring (4 freely configurable network connections, quality table with 10000 storage depth, events protocol (logbook) for 10000 events, actual value graphic with 16 curves, 4 envelope curves monitoring, SPC charts, trend diagrams)
 Mold identification
 Special programs on customer request
 HiQ Cushion® - melt cushion control
 HiQ Flow® - injection integral control
 HiQ Melt - monitoring of material quality
 HiQ Packing® - holding pressure speed limitation
 Energy consumption analysis
 Clamp force supervision
 Special programs on customer request
 Purge of cold plug
 Additional output card/input card, freely programmable
 Integration package WITTMANN 4.0
 Control panel free-standing or mounted on a pivotable arm

Additional equipment

Tool kit
 Levelling pads
 Lighting in mold space
 Mold clamping systems in mechanical, electrical or hydraulic execution
 Platform for safe access to the injection unit in V-position incl. protection with transponder switch
 Integration package (robot, feeder, dosing unit, TCU, mold integration)
 WITTMANN BATTENFELD web service during warranty period free of charge
 Remote control package

The Wittmann logo is located in the bottom right corner of the page. It consists of the word "Wittmann" in a white, italicized, sans-serif font, set against a dark red, rounded rectangular background.

WITTMANN BATTENFELD GmbH

Wiener Neustädter Straße 81
2542 Kottlingbrunn | Österreich
Tel.: +43 2252 404-0
info@wittmann-group.com
www.wittmann-group.com