

AUTO FEEDER SYSTEM(OPTIONAL)

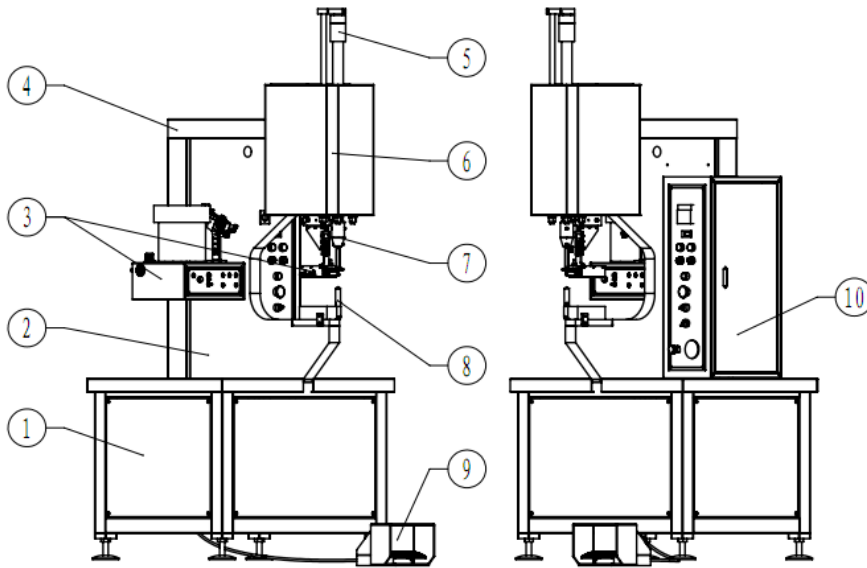

- 1. Hydraulic power pack 2. C Frame 3. Auto Feeder System 4. Hydraulic tube and enclosure
- 5. Positive stop nut tube 6. Hydraulic cylinder and enclosure 7. Top feed shuttle for stud
- 8. Lower tool holder assembly 9. Foot switch 10. Panel and Electrical box

1. Auto feeder system for stud

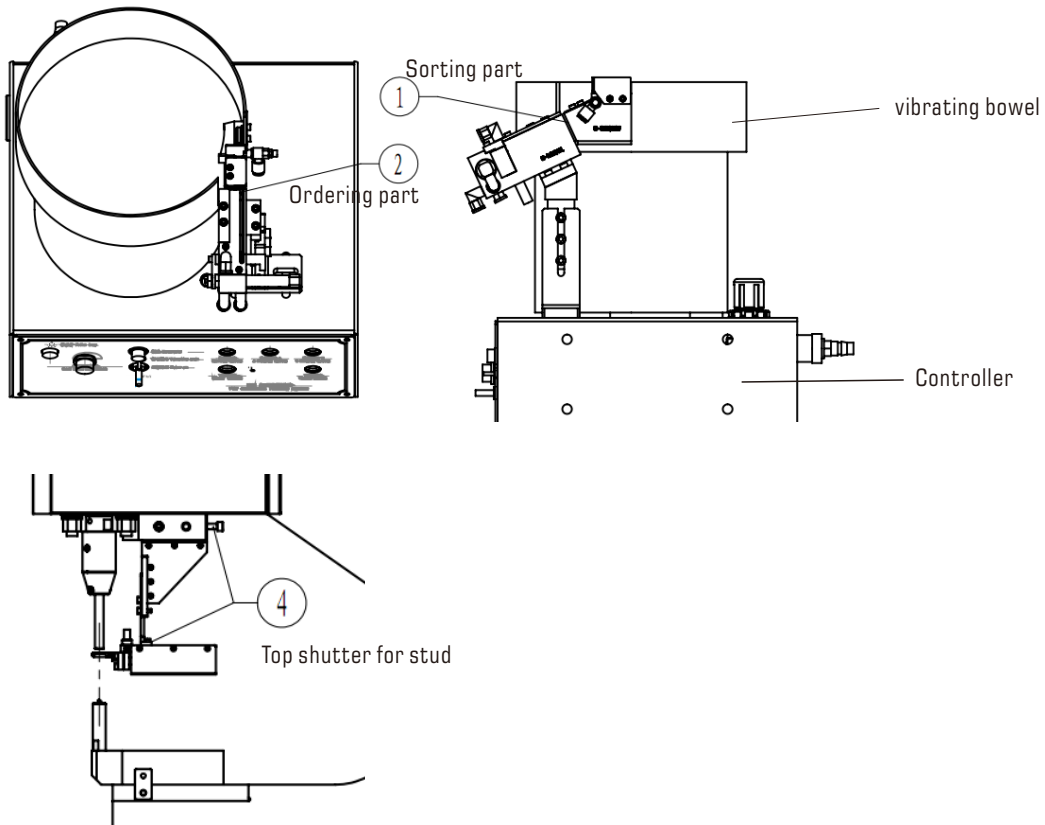

2.Auto feeder system for nut

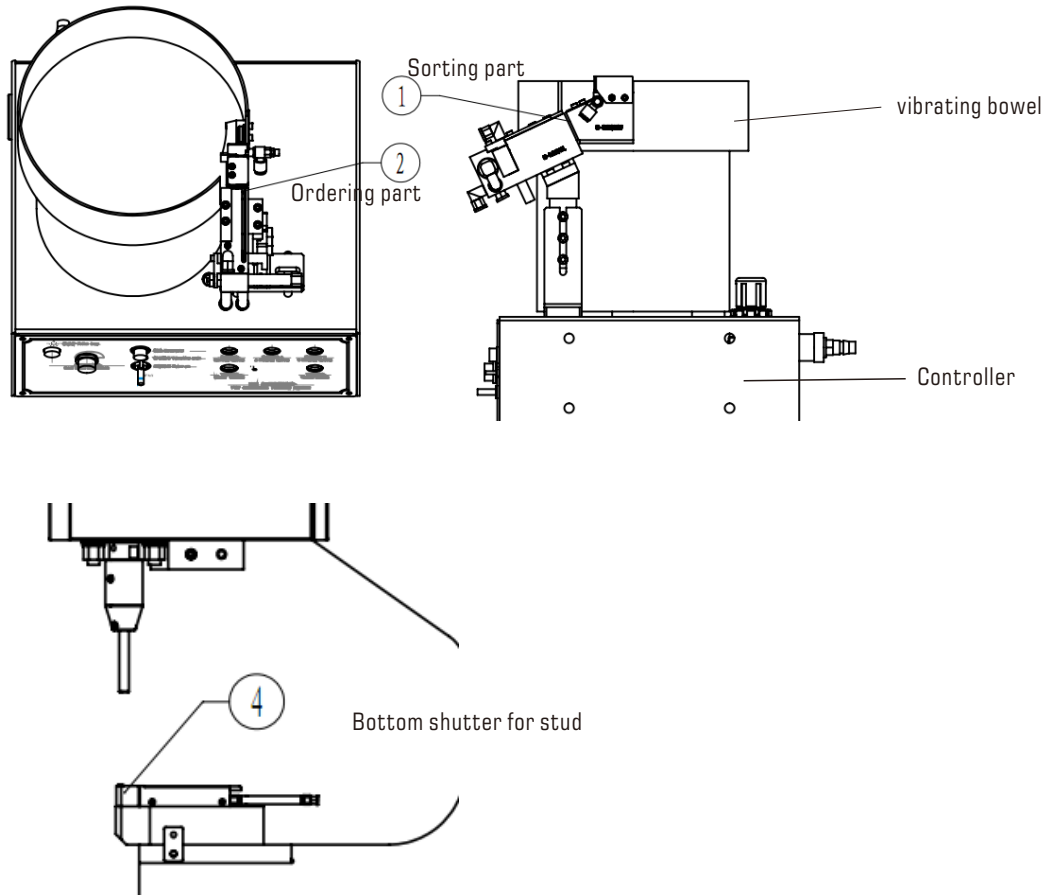

MANUAL TOOL (Free tool kits, 12 tools)

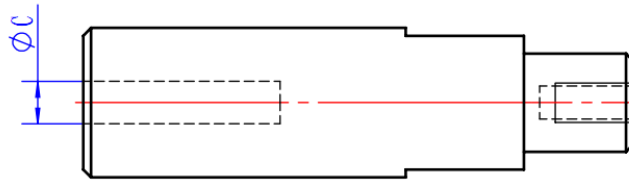

	ϕC
SO-M3	4.22-4.30
SO-3.5M3/M3.5	5.41-5.49
SO-M4	6.02-6.10
SO-3.5M4/M5	7.14-7.22

4 Tools for SO-M3 ; SO-3.5M3/SO-M3.5 ; SO-M4 ; SO-3.5M4/SO-M5

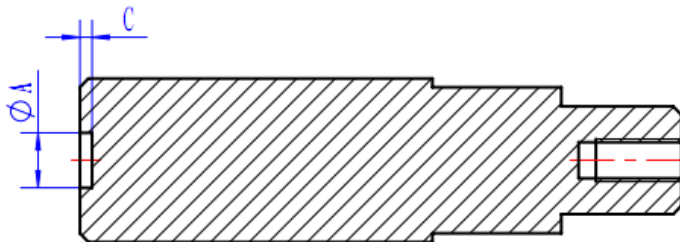

	$\phi A+0.1/0$	$C+0/-0.05$
M3	6.4	1.4
M4	8.0	1.9
M5	8.8	1.9
M6	11.2	3.95

4 Tools for S-M3 ; S-M4 ; S-M5 ; S-M6

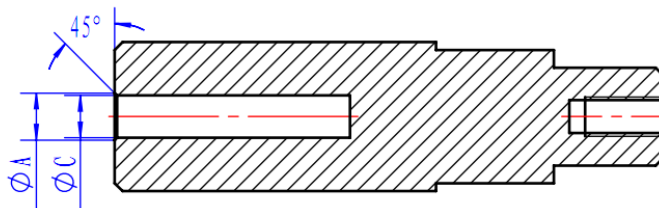

	$\phi A+0.1/0$	$\phi C+0.08/0$
M3	3.6	3.03
M4	4.6	4.03
M5	5.6	5.03
M6	6.6	6.03

4 Tools for FH-M3 ; FH-M4 ; FH-M5 ; FH-M6

